

882818-03 Rev. A  
October 1994  
Printed in Taiwan

Wyse Technology Inc.  
3471 North First Street  
San Jose, CA 95134-1803 U.S.A.

**WYSE**  
| | | |

**WY-55/ES**  
**User's Guide**

**WYSE**  
| | | |

---

**COPYRIGHT NOTICE**

© 1994 Wyse Technology Inc. ALL RIGHTS RESERVED.

This manual and the software and firmware described in it are copyrighted by Wyse Technology Inc. You may not reproduce, transmit, transcribe, store in a retrieval system, or translate into any language or computer language, in any form or by any means, electronic, mechanical, magnetic, optical, chemical, manual, or otherwise, any part of this publication without the express written permission of Wyse Technology Inc.

---

**TRADEMARKS**

WYSE and WY are a registered trademarks of Wyse Technology Inc. WY-50, WY-50+, WY-55, WY-55ES, WY-60, WY-120, WY-120ES, WY-150, and WY-150ES are trademarks of Wyse Technology Inc.

All other trademarks are the property of their respective companies.

---

**DISCLAIMER**

Wyse Technology Inc. makes no representations or warranties regarding the contents of this document. We reserve the right to revise this document or make changes in the specifications of the product described within it at any time without notice and without obligation to notify any person of such revision or change.

---

**RESTRICTED RIGHTS LEGEND**

Use, duplication, or disclosure by the Government is subject to restrictions as set forth in subparagraph (c)(1)(ii) of the Rights in Technical Data and Computer Software clause at 252.277-7013.

WYSE TECHNOLOGY INC.  
3471 North First Street  
San Jose, CA 95134-1803 U.S.A.

---

**FCC NOTICE**

**Note** This equipment has been tested and found to comply with the limits for a Class A digital device, pursuant to Part 15 of the FCC Rules. These limits are designed to provide reasonable protection against harmful interference when the equipment is operated in a commercial environment. This equipment generates, uses, and can radiate radio frequency energy and, if not installed and used in accordance with the instruction manual, may cause harmful interference to radio communications. Operation of this equipment in a residential area is likely to cause harmful interference in which case the user will be required to correct the interference at his own expense.

**Caution** Changes or modifications not covered in this manual must be approved in writing by the manufacturer's Regulatory Engineering department. Changes or modifications made without written approval may void the user's authority to operate this equipment.

---

**CANADIAN DOC NOTICE**

This digital apparatus does not exceed the Class A limits for radio noise emissions from digital apparatus set out in the Radio Interference Regulations of the Canadian Department of Communications.

Le présent appareil numérique n'émet pas de bruits radioélectriques dépassant les limites applicables aux appareils numériques de la classe A prescrites dans le Règlement sur le brouillage radioélectrique édicté par le Ministère des Communications du Canada.

---

**SWEDAC NOTICE**

The WY-55ES product meets the guidelines of MPR 1990:10.

---

**IEC/EN/CISPR NOTICE**

This product conforms to the requirements of IEC 950 and EN 60950.

This product conforms to the requirements of CISPR 22 and EN 55022 for Class B equipment.

---

**CABLE NOTICE**

The use of shielded I/O cables is required when connecting this equipment to any and all optional peripheral or host devices. Failure to do so may cause interference and violate FCC and international regulations for electromagnetic interference.



# Contents

<b>Preface</b> .....	v
<b>Basic Terminal Operation</b> .....	1
Terminal Features .....	1
Installing the Terminal .....	1
Connecting the Terminal .....	2
Turning On the Terminal .....	3
Clearing an Error Condition .....	3
Adjusting the Terminal .....	4
Setting Up the Terminal .....	4
Entering Setup Mode .....	5
Aligning the Screen Display .....	7
Changing the Operating Parameters .....	7
Setting Tab Stops .....	25
Defining an Answerback Message .....	26
Redefining the Keys .....	27
Scheduling a Rest .....	29
Key Functions .....	29
Display Features .....	32
Terminal Status Messages .....	32
Screen Saver .....	34
Printing .....	34
<b>A Connector Pin Assignments</b> .....	A-1
<b>B Composing Characters</b> .....	B-1
Introducing Compose Sequences .....	B-1
Entering Compose Sequences .....	B-1
Canceling Compose Sequences .....	B-2

Nonspacing Diacritical Marks .....	B-2
Composing Characters in ASCII Personalities .....	B-4
Composing Characters in National Mode (ASCII Personalities) .....	B-5
Composing Characters in Multinational Mode (ASCII Personalities) .....	B-6
Composing Characters in ANSI Personalities .....	B-19
Composing Characters in National Mode (ANSI Personalities) .....	B-19
Composing Characters in Multinational Mode (ANSI Personalities) .....	B-22

<b>Index</b> .....	Index-1
--------------------	---------

### List of Figures

1	The Back Panel .....	2
2	Terminal Controls .....	3
3	Setup Directory .....	6
4	Tabs Menu .....	25
5	Fkeys Menu .....	27
A-1	MODEM Port Connector Pin Assignments (RS-232C) ..	A-1
A-2	AUX Port Connector Pin Assignments (RS-232C) .....	A-2
A-3	Parallel Port Connector Pin Assignments (ES Models Only) .....	A-3

### List of Tables

1	Display Menu Setup Parameters .....	8
2	General Menu Setup Parameters .....	10
3	Keyboard Menu Setup Parameters .....	12
4	COMM Menu Setup Parameters .....	15
5	Ports Menu Setup Parameters .....	17
6	Miscellaneous Menu Setup Parameters .....	19
7	ANSI 1 Menu Setup Parameters .....	21
8	ANSI 2 Menu Setup Parameters .....	23
9	Local Keyboard Commands by Keyboard Style .....	30
10	Terminal Status Messages .....	32
B-1	Nonspacing Diacritical Marks (ASCII Keyboard) .....	B-2
B-2	Nonspacing Diacritical Marks (105-Key ANSI Keyboard) .....	B-3
B-3	Nonspacing Diacritical Marks (International Enhanced PC-Style Keyboard) .....	B-3

**T**

Tabs, 25

**Terminal**

- features, 1
- identification, 22
- installing, 1
- personalities, 7, 10, 11

- resetting, 30, 33, 34
- status messages, 32–33, B-2

**U**

User-Preferred Supplemental Set, 21

**V**

Vertical Alignment, screen display, 7

B-4	Compose Character Sequences: National Mode (ASCII Personalities) .....	B-5
B-5	Compose Character Sequences: Multinational Mode (ASCII Personalities) .....	B-8
B-6	Compose Character Sequences: National Mode (ANSI Personalities) .....	B-20
B-7	Compose Character Sequences: Multinational Mode (ANSI Personalities) .....	B-23

Keyclick, 12  
 Keycode, 12, 16, 31  
 Keylock, 12  
 Keypad, 22  
 Keys, 25  
 Language, 12  
 Lines, 8  
 Margin Bell, 19  
 Mdm Baud Rate, 17  
 Mdm Data/Parity, 17  
 Mdm Rc Hsk, 15, 34  
 Mdm Rc Hsk Level, 15  
 Mdm Stop Bits, 17, 18  
 Mdm Xmt Hsk, 16  
 Monitor, 11  
 Multiple Page, 20  
 Newline, 23  
 Nulls Suppress, 19  
 Page, 8  
 Personality, 10, 29  
 Print, 23  
 Print Area, 24  
 Print Term, 24  
 Printer Attached, 18  
 Rcv CR, 10  
 Recognize DEL, 11  
 Repeat, 12  
 Rest/Act. Timer, 21, 29  
 Scrl, 10  
 Scrn Saver, 9, 31  
 Send, 24  
 Send ACK, 16  
 Send Area, 24  
 Send Term, 24  
 Status Line, 11  
 WPRT Intensity, 19  
 WPRT Rev, 20  
 WPRT Undrln, 20  
 Wrap EOL, 11

Xfer Term, 24  
 Xmt Lim, 15  
 Parity, 17, 18  
 Personalities, 7, 10, 11  
 Ports  
   configuring, 15, 17, 18, 34  
   connecting, 2, A-1  
   parallel, 2  
   status messages, 33  
 Printing, 18, 23, 30, 33, 34

## ■ R

Resetting terminal, 30, 33, 34  
 Rest timer, 21, 29

## ■ S

Saving setup changes, 6, 26, 29  
 Scan codes, 5, 6, 12, 16, 31  
 Screen  
   aligning, 7  
   areas, 8, 24  
   brightness, 3, 4  
   contrast, 3, 4  
   format, 32  
   reverse, 9  
   saver, 9, 30  
   splitting, 30  
 Scroll speed, 10, 31  
 Setup mode  
   aligning screen, 7  
   changing operating parameters, 7  
   entering, 5, 30  
   exit options, 6  
   menus, 7-24, 25, 27  
   saving changes, 6  
 Soft reset, 30, 33  
 Status line, 11, 32-33, B-2  
 Stop bits, 18

**K**

## Keyboard

- connecting, 2
- diacritical marks, B-2–B-5
- language, 12–13, B-2, B-5, B-20
- local commands, 30
- rest timer, 21, 29

## Keys

- codes, 12, 16, 29, 31
- composing characters, B-1
- conventions, v
- corner, 13, B-1, B-7
- direction, 28
- function, 27
- keyclick, 12, 30
- keylock, 12
- local commands, 30
- redefining, 27
- repeating, 12
- scan codes, 5–6, 12, 16, 30

**L**

- Language, keyboard, 12, 13, B-20
- Lines, 8, 32
- Local keyboard commands, 30
- Local mode, 15, 32

**M**

- Memory, 6, 11, 29, 31
- Menus, setup mode, 6–23, 25, 27
- Modem port, 2, A-1
- Monitor mode, 11, 30
- Multinational mode, 13, 22, B-1, B-6–B-7, B-22

**N**

- National mode, 13, 22, B-1, B-5, B-19

**P**

## Pages

- clearing, 31
- displaying, 20, 31
- printing, 30
- Parallel port, 2, A-3
- Parameters, setup
  - 80/132 Clr, 9
  - ANSI ID, 22
  - Answerback Mode, 16
  - ASCII, 13, B-1
  - ASCII Font, 13
  - Attribute, 20
  - Auto Answerback, 24
  - Autopage, 9
  - Autoscr1, 9, 11
  - Aux Baud Rate, 17
  - Aux Data/Parity, 17
  - Aux Rc Hsk, 15
  - Aux Stop Bits, 18
  - Aux Xmt Hsk, 16
  - Bell Volume, 20
  - Blk End, 19
  - Char Cell, 9
  - Char Mode, 22
  - Char Set, 21, B-1
  - Codepg, 13
  - Columns, 8
  - Comm, 15
  - Corner Key, 13, B-2
  - Cursor, 8, 22
  - Cursor Keys, 22
  - DEL, 23
  - Display, 8, 19
  - Down Key, 14
  - Enhance, 11
  - Feature Lock, 22
  - Fkey Lock, 22
  - Host Port, 17

# Preface

This guide provides you with the basic information you'll need to quickly install, set up, and operate the terminal.

The guide is organized as follows:

- “Basic Terminal Operation” describes what you need to know to install, set up, and operate the terminal.
- Appendix A, “Connector Pin Assignments,” shows the pin assignments for the Modem and Aux ports.
- Appendix B, “Composing Characters,” describes how to create characters that do not appear as standard keys on your keyboard.
- An index follows at the end of the guide.

In the text, the names of keys are boxed, for example, **Return**. The name of the key on the ASCII keyboard is always mentioned first, followed in parentheses by the names of the equivalent keys on other keyboard styles if they are different. For example, **Setup** (**F3**, **Select**) means **Setup** on the ASCII keyboard, **F3** on the 105-Key ANSI keyboard, or **Select** on the Enhanced PC-style keyboard.

When necessary, an italic notation follows a key name to identify the specific location of the key. For example, the notation **5***kpd* signifies that the key is located on the *numeric keypad* at the right side of the keyboard; the notation **Alt***left* or **Alt***right* specifies one of the two ALT keys on the Enhanced PC-style keyboard.



# Index

## ■ A

ACK, 16  
Activity/rest timer, 21, 29  
Alignment, setup screen, 6  
ANSI, setup parameters, 21, 22–24  
Answerback, 16, 24, 26, 28, 31  
Attributes, display, 19, 20, 23  
Aux port, 2, A-2, A-3  
Auxiliary print mode, 30, 33

## ■ B

Battery-backed memory, 6, 26, 29  
Baud rate, 17  
Bell, 3, 12, 19, 20, 21, 29  
Block mode, 15, 30, 33, 34  
Buffer, 27

## ■ C

Character sets, 13, 21, B-1  
Characters  
    attributes, 19, 20, 23  
    composing, 13, 32, B-1  
    data processing, 25  
    multinational mode, 13, 22, B-2, B-22  
    national mode, 13, 22, B-1, B-5, B-19  
    national replacement, 13, 22  
    printing, 18, 23, 34  
    write-protected, 20  
Columns, 8, 26, 32  
Commands, local keyboard, 30

Communication modes, 15, 32  
Compose sequences, B-1–B-3  
Connector pin assignments, A-1  
Corner key, 13, B-1, B-7  
Cursor  
    display, 8  
    end-of-line wrap, 11  
    movement, 8, 11, 14, 22, 31

## ■ D

Data, holding, 13, 33  
Data bits, 17, 18  
Defaults, setting, 6  
Diacritical marks, B-2–B-5  
Display attributes, 19, 20, 23  
Down Key, 14

## ■ E

Enhance mode, 11  
Error code, clearing, 3

## ■ F

Features, 1  
Full-duplex mode, 15, 32  
Function keys, 27

## ■ H

Half-duplex block mode, 15, 33  
Half-duplex mode, 15, 32  
Handshaking, 5, 15, 16  
Hard reset, 30



**Table B-7 Compose Character Sequences: Multinational Mode (ANSI Personalities), Continued**

Comp. Char.	Description	Sequence		Multi-national	ISO Latin-1	ISO Latin-2	ISO Latin-5	ISO Cyrillic	Cyrillic	Turkish
		3-Key <sup>1</sup>	2-Key <sup>2</sup>							
`	Grave accent	` SP	` SP	•	•	•	•	•	•	•
[	Left bracket	( (		•	•	•	•	•	•	•
\	Backslash	/ /	/ <	•	•	•	•	•	•	•
]	Right bracket	) )		•	•	•	•	•	•	•
^	Circumflex	^ SP	^ SP	•	•	•	•	•	•	•
{	Left brace	( -		•	•	•	•	•	•	•
	Vertical line	/ ^	^ /	•	•	•	•	•	•	•
}	Right brace	) -		•	•	•	•	•	•	•
~	Tilde	~ SP	~ SP	•	•	•	•	•	•	•

1. First press the corner key. The other two keys can be pressed in any order.
2. Any sequence in this column can also be used to compose a three-key sequence. The difference is that for a two-key sequence, the two keys must be pressed in the order shown in this column; for a three-key sequence, you must first press the corner key, but the two keys can be pressed in any order.
3. Alphabetic characters can be entered in uppercase or lowercase.
4. Available only in the following keyboard languages: Czech, Hungarian, Polish, Romanian, Slovak, SCS, Turkish, and Russian.
5. Not available in the following keyboard languages: Czech, Hungarian, Polish, Romanian, Slovak, SCS, Turkish, and Russian.



# Basic Terminal Operation

## TERMINAL FEATURES

Your standard display terminal features:

- ASCII, ANSI, PC Term, and UNIX Console operating modes (*personalities*)
- A 26- or 44-line by 80- or 132-column display
- Up to 80 hertz refresh rate with overscan
- Multiple keyboard options with international language support, 8-bit ASCII support, and programmable function and editing keys
- A *rest timer* for scheduling work breaks in accordance with industry recommendations for working at display terminals

Your ES-model display terminal features:

- Low emissions
- A parallel port

## INSTALLING THE TERMINAL

To get ready to install the terminal,

- Choose a location away from direct sunlight or other sources of bright, direct light.
- Place the terminal on a flat, hard surface, allowing three inches on all sides for ventilation and external cabling.
- Make sure you have a grounded power outlet that accommodates a three-pronged plug.
- Make sure the terminal's power switch (shown in Figure 2) is in the *off* position (slide it to the left as far as it will go).

See Appendix A for connector pin assignments.

Figure 1 shows the connectors on the terminal's back panel. You can connect a host computer or other serial device to either serial port with a shielded serial interface cable fitted with a male 25-pin connector on the terminal end.

- Note** The use of shielded I/O cables is required when connecting this equipment to any and all optional peripheral or host devices. Failure to do so might violate FCC rules.

**Figure 1 The Back Panel**

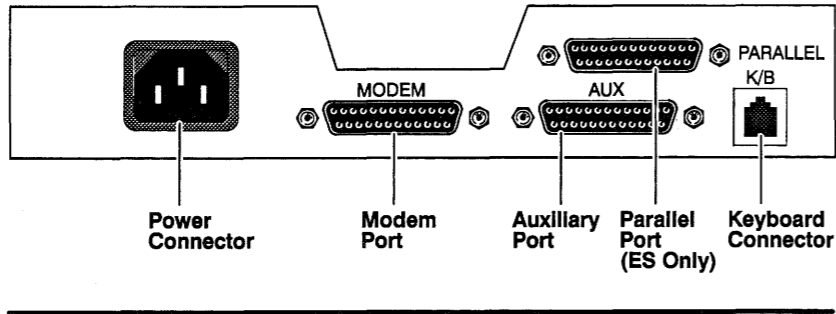

**Connecting the Terminal**

To connect the terminal to your computer and to other external devices, follow these steps:

If you connect your computer to the Aux port, you must change the Host Port setup parameter to Aux Port (see Table 5).

- 1 Plug one end of the keyboard cable into your keyboard and the other end into the keyboard connector.
- Note** Do not attempt to connect any keyboard except one of the keyboards specifically offered with this terminal.
- 2 Connect your computer or modem to the Modem port.
- 3 Connect the printer:
  - If you have a serial printer, connect it to the Aux port.
  - If you have a parallel printer, connect it to the Parallel port.
- 4 Connect one end of the power cord to the three-pronged power connector, and plug the other end into a grounded power outlet.

**Table B-7 Compose Character Sequences: Multinational Mode (ANSI Personalities), Continued**

Comp. Char.	Description	Sequence 3-Key <sup>1</sup>	Sequence 2-Key <sup>2</sup>	Multi-national	ISO Latin-1	ISO Latin-2	ISO Latin-5	ISO Cyrillic	Cyrillic	Turkish
½	One-half	1 2		•	•		•			•
¼	One-fourth	1 4		•	•		•			•
¾	Three-fourths	3 4			•		•			
¡	Broken bar	! ^ !	^ !		•		•			
ª	Feminine ordinal <sup>3</sup>	A _		•	•		•			•
º	Masculine ordinal <sup>3</sup>	O _		•	•		•			•
§	Section <sup>3</sup>	S ! S O S 0		•	•	•	•	•		•
¶	Paragraph <sup>3</sup>	P !		•	•	•	•			•
©	Copyright <sup>3</sup>	C O C 0		•	•		•			•
®	Registered trademark	R O			•		•			
µ	Micro <sup>3</sup>	/ U		•	•		•			•
¬	Logical not	- ,			•		•			
"	Quotation mark	" SP " SP		•				•	•	•
#	Number/pound	+ +		•	•	•	•	•	•	•
'	Apostrophe	' SP ' SP <sup>5</sup>		•	•	•	•	•	•	•
@	At <sup>3</sup>	A A		•	•	•	•	•	•	•

**Table B-7 Compose Character Sequences: Multinational Mode (ANSI Personalities), Continued**

Comp. Char.	Description	Sequence		Multi-national	ISO Latin-1	ISO Latin-2	ISO Latin-5	ISO Cyrillic	Cyrillic	Turkish
		3-Key <sup>1</sup>	2-Key <sup>2</sup>							
✓	Hacek	✓ SP	✓ SP			•				
✓	Breve	u u U U	✓ SP			•				
•	Ring or degree	0 ^ SP + SP o	^ 0 : . ^ .	•	•	•	•			•
•	Dot above	• SP	• SP			•				
•	Umlaut	• • • SP	• • • SP		•	•	•			
•	Macron	• ^ • ^	• ^ • ^		•		•			
•	Middle dot	• ^ • ^	• ^ • ^	•	•		•			•
<<	Left angle brackets	< <		•	•		•			•
>>	Right angle brackets	> >		•	•		•			•
±	Plus or minus	+ -		•	•		•			•
÷	Division sign	- :			•	•	•			
×	Multiplication sign	x x			•	•	•			
<sup>1</sup>	Superscript 1	1 ^	^ 1	•	•		•			•
<sup>2</sup>	Superscript 2	2 ^	^ 2	•	•		•			•
<sup>3</sup>	Superscript 3	3 ^	^ 3	•	•		•			•

**Turning On the Terminal**

Slide the power switch on the front of the terminal (see Figure 2) to the right until it clicks into position. You'll see the power indicator light turn on and hear an immediate beep if the terminal is receiving power. The terminal immediately runs a brief self-test during which patterns or messages might be displayed on the screen.

**Figure 2 Terminal Controls**

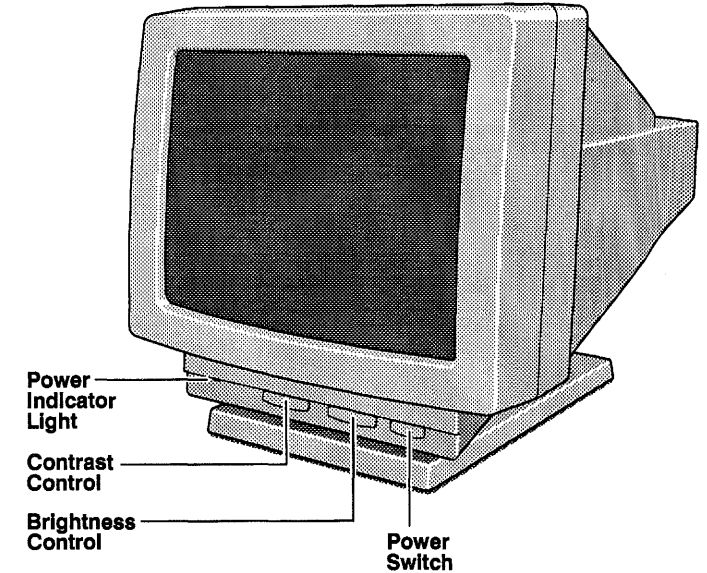

**Clearing an Error Condition**

If the bell sounds and an error code appears at the bottom of the screen,

- 1 Make a note of the error code letter or number.
- 2 Press **SetUp** (**Shift** **F3**, **Select**) to clear the error condition.
- 3 Enter setup mode (see "Setting Up the Terminal") and press **Enter** *kpd* to default the parameters to their factory settings.
- 4 Save the default settings and exit setup mode.
- 5 Enter setup mode and set up the terminal according to your system requirements.
- 6 Save the settings and exit setup mode.

See "Setting Up the Terminal," for more information about steps 3, 4, 5, and 6.

If the error code continues to appear, call your service representative and report the error code. The terminal might need to be serviced by a qualified technician.

**Adjusting the Terminal**

Tilt and swivel the screen to find the best viewing angle. If you prefer the keyboard tilted slightly, turn it over and pull out the hinged feet.

To adjust the brightness and contrast of the screen display, slide both the brightness and contrast controls (Figure 2) to the right as far as they will go. Then slide each control to the left until the brightness and contrast are comfortable for you.

If at any time the top or bottom lines of the screen display are not completely visible, you can adjust the display vertically on the screen. You do this in setup mode, as described in the next section.

**SETTING UP THE TERMINAL**

This section tells you how to set the terminal's operating parameters in setup mode. In general, setup parameters fall into three groups:

- Parameters that must be set to match the requirements of your computer or other connected device for communication to be successful
- Parameters that must be set to match the requirements of particular application programs
- Parameters that you can set to suit your personal preferences

Consult your computer, printer, and application user's manuals for instructions about their setup requirements.

**Note** Parameter settings apply to both versions of the terminal (standard and ES) unless specified otherwise.

**Table B-7 Compose Character Sequences: Multinational Mode (ANSI Personalities), Continued**

Comp. Char.	Description	Sequence		Multi-national	ISO Latin-1	ISO Latin-2	ISO Latin-5	ISO Cyrillic	Cyrillic	Turkish
		3-Key <sup>1</sup>	2-Key <sup>2</sup>							
ß	German small sharp s	s	s	•	•	•	•			•
Þ	Capital Icelandic thorn	T	H		•					
þ	Small Icelandic thorn	t	h		•					
¤	Currency <sup>3</sup>	X O X 0		•	•	•	•			•
£	Pound <sup>3</sup>	L - L =		•	•		•			•
¢	Cent <sup>3</sup>	C / C		•	•		•			•
¥	Yen <sup>3</sup>	Y - Y =		•	•		•			•
¡	Inverted exclamation mark	!	!	•	•		•			•
¿	Inverted question mark	?	?	•	•		•			•
	No break space (NBSP)	SP	SP		•		•	•		
-	Soft syllable hyphen (SHY)	- - - -			•	•	•	•		
'	Acute accent	' '	' ' SP <sup>4</sup>		•	•	•			
¨	Double acute	' "	'' SP '' "			•				
˙	Ogonek	˙ SP c SP C SP	˙ SP ˙			•				
¸	Cedilla	, SP , ,	, SP , ,		•	•	•			

**Table B-7 Compose Character Sequences: Multinational Mode (ANSI Personalities), Continued**

Comp. Char.	Description	Sequence		Multi-national	ISO Latin-1	ISO Latin-2	ISO Latin-5	ISO Cyrillic	Cyrillic	Turkish
		3-Key <sup>1</sup>	2-Key <sup>2</sup>							
š	s hacek	s ˇ s V s v	ˇ s			•				
ť	t hacek	t ˇ t V t v	ˇ t			•				
ţ	t cedilla	t ,	, t			•				
û	u grave	u `	` u	•	•		•			•
ú	u acute	u ' / u ´	' u	•	•	•	•			•
ü	u umlaut	u ¨ u "	¨ u	•	•	•	•			•
ú	u double acute	u " "	" u			•				
û	u circumflex	u ^	^ u	•	•		•			•
û	u ring	u ° u O u o u *	° u			•				
ý	y acute	y ' / y ´	' y		•	•				
ÿ	y umlaut	y ¨ y "	¨ y	•	•		•			•
ž	z acute	z ' / z ´	' z			•				
ž	z hacek	z ˇ z V	ˇ z			•				
ž	z dot above	z .	. z			•				

**Entering Setup Mode**

Press **Ctrl** **Setup** if terminal has been set up for PC Term personality or for PC scan codes.

To enter setup mode,

- Press **Shift** **Setup** or **Ctrl** **Setup** if you have the ASCII keyboard

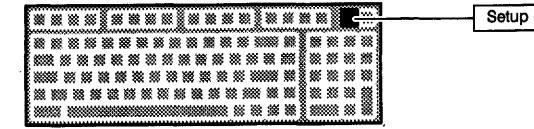

**ASCII Keyboard**

Press **Ctrl** **Select** if terminal has been set up for PC Term personality or for PC scan codes.

- Press **F3** or **Ctrl** **Select** if you have the 105-Key ANSI keyboard

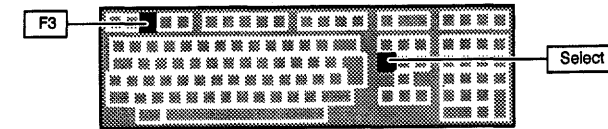

**105-Key ANSI Keyboard**

Press **Ctrl** **Select** if terminal has been set up for PC Term personality or for PC scan codes.

- Press **Shift** **Select** or **Ctrl** **Select** if you have the Enhanced PC-style keyboard

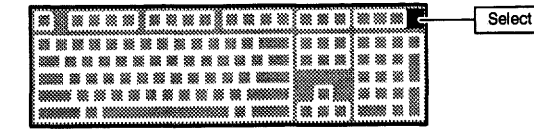

**Enhanced PC-Style Keyboard**

**Caution** If handshaking is not enabled, data can be lost if you enter setup mode while the terminal is receiving data.

Figure 3 shows the setup directory screen.

Figure 3 Setup Directory

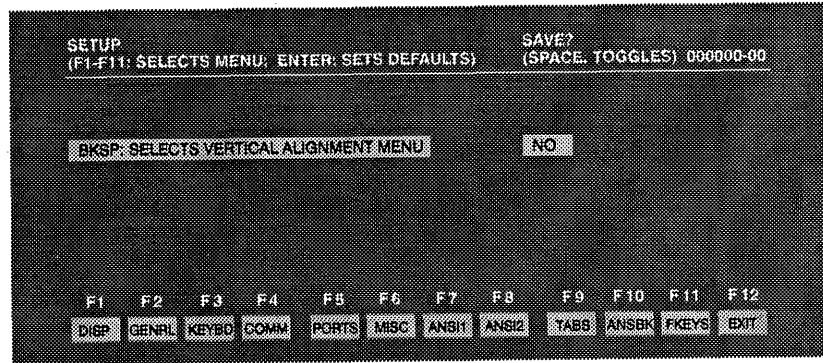

From the setup directory screen you can select setup menus, or you can exit setup mode and return the terminal to the normal operating mode. The setup directory screen includes the following features:

- The field at the center left of the screen is replaced by the vertical alignment menu when you press **Back Space** (**⌫**), **← Back Space**. See the next section, "Aligning the Screen Display."
- The highlighted field to the right of the vertical alignment field displays the Save? setting (default is *No*). This field gives you the choice of saving or not saving changes in the terminal's battery-backed memory before you exit setup mode.
  - If you select the *No* option, any changes you have made remain in effect only until you turn off the power.
  - If you select the *Yes* option (by pressing **Spacebar**), all settings *except* function key redefinitions and the answerback message remain in effect until you change them.
  - If you select the *All* option (by pressing **Spacebar**), all settings *including* the function key redefinitions and the answerback message remain in effect until you change them.
- The fields at the bottom of the screen identify the setup menus you can display to change the terminal's operating parameters.
- Pressing **Enter** *kpd* restores all settings to their factory-default values.
- Pressing **F12** exits setup mode.

*Exception: When Buffer is set to NVR on the Fkeys menu (Figure 5), the answerback message and key redefinitions are automatically saved in battery-backed memory.*

Table B-7 Compose Character Sequences: Multinational Mode (ANSI Personalities), Continued

Comp. Char.	Description	Sequence 3-Key <sup>1</sup>	Sequence 2-Key <sup>2</sup>	Multi-national	ISO Latin-1	ISO Latin-2	ISO Latin-5	ISO Cyrillic	Cyrillic	Turkish
ñ	n acute	n ' n	n n			•				
ñ	n tilde	n ~ ñ	~ n	•	•		•			•
ñ	n hacek	n ˇ n n V n v	ˇ n V n v n			•				
ò	o grave	o ` o	` o	•	•		•			•
ó	o acute	o ' o	' o	•	•	•	•			•
ô	o double acute	o " o	" o			•				
ô	o circumflex	o ^ o	^ o	•	•	•	•			•
ö	o umlaut	o " o	" o	•	•	•	•			•
œ	oe ligature	o e		•						•
õ	o tilde	o ~ õ	~ o	•	•		•			•
ø	o slash	o / ø	/ o	•	•		•			•
ř	r acute	r ' r	' r			•				
ř	r hacek	r ˇ r r V r v	ˇ r V r v r			•				
ś	s acute	s ' s	' s			•				
š	s cedilla	s , š	, s			•	•			•

**Table B-7 Compose Character Sequences: Multinational Mode (ANSI Personalities), Continued**

Comp. Char.	Description	Sequence		Multi-national	ISO Latin-1	ISO Latin-2	ISO Latin-5	ISO Cyrillic	Cyrillic	Turkish
		3-Key <sup>1</sup>	2-Key <sup>2</sup>							
è	e grave	e `	` e	•	•		•			•
é	e acute	e ' / e ´	' e / ´ e	•	•	•	•			•
ê	e circumflex	e ^	^ e	•	•		•			•
ë	e umlaut	e " / e ¨	" e / ¨ e	•	•	•	•	•		•
ę	e ogonek	e ˛ / e Ć / e Ć	˛ e / Ć e / Ć e			•				
ě	e hacek	e ˇ / e V / e v	ˇ e / V e / v e			•				
ġ	g breve	g ˘	˘ g				•			•
ì	i grave	i `	` i	•	•		•			•
í	i acute	i ' / i ´	' i / ´ i	•	•	•	•			•
î	i circumflex	i ^	^ i	•	•	•	•			•
ï	i umlaut	i " / i ¨	" i / ¨ i	•	•		•	•		•
ı	i without dot	· i	· i				•			•
ĺ	l acute	l ' / l ´	' l / ´ l			•				
ļ	l hacek	l ˇ / l V / l v	ˇ l / V l / v l			•				
ł	l with stroke	l /	/			•				

**Note** The internal identification number at the top right of the screen has no significance for setup mode operation.

**Aligning the Screen Display**

To adjust the vertical position of the screen display (for example, if the status line is ever partially cut off at the top of the screen),

1 Press **Back Space** (**↵**, **← Back Space**) to display the vertical alignment menu:

**UP/DOWN ARROW: VERTICAL ALIGNMENT: BKSP: EXITS**

2 Press **↓** (**↓**) to move the screen display down, or **↑** (**↑**) to move the screen display up. As you can see on the vertical alignment menu, each time you press the key, the display moves in small increments in the direction of the arrow.

3 Press **Back Space** (**↵**, **← Back Space**) to exit the vertical alignment menu and return to the setup directory screen.

4 Press **F12** to exit setup mode.

If the new vertical alignment of the screen display in normal operating mode is not satisfactory, reenter setup mode to make further adjustments.

**Changing the Operating Parameters**

*If the terminal has been set up for you, mark the tables in this section to record the settings of the parameters on the setup menus. This will save you time and trouble if for any reason the terminal is reset to the factory-default values.*

To select one of the setup menus named on the bottom line, press the indicated function key (**F1** through **F11**):

- The screen displays a group of operating parameter fields showing the current setting for each parameter.
- You can change a parameter setting by pressing the cursor keys to highlight the parameter field and **Spacebar** or **Back Space** (**↵**) to select the new setting.

Tables 1 through 8 list the parameters on each setup menu and explain the meanings of the parameter settings. The default setting, shown in **bold**, is always listed first. *In the tables, not all parameters or parameter settings apply to every personality. Depending on the personality you select, some parameters and some settings may not appear on the setup menus.*

**Note** If you select a parameter setting that is invalid for the current personality, the terminal defaults to a valid setting upon leaving setup mode. Also, the terminal might force certain standard parameter settings for various personalities; for this reason, if you change the terminal's personality, always exit and reenter setup mode before changing other settings.





**Table B-7 Compose Character Sequences: Multinational Mode (ANSI Personalities), Continued**

Comp. Char.	Description	Sequence		Multi-national	ISO Latin-1	ISO Latin-2	ISO Latin-5	ISO Cyrillic	Cyrillic	Turkish
		3-Key <sup>1</sup>	2-Key <sup>2</sup>							
Ş	S hacek	S S S	∨ V v			•				
Ţ	T cedilla	T	, T			•				
Ţ	T hacek	T T T	∨ V v			•				
Û	U grave	U	` U	•	•		•			•
Ú	U acute	U U	' ı	•	•	•	•			•
Û	U umlaut	U U	" "	•	•	•	•			•
Û	U double acute	U	¨ U				•			
Û	U circumflex	U	^ U	•	•		•			•
Û	U ring	U U U U	• o o *			•				
Ý	Y acute	Y Y	' ı		•	•				
ÿ	Y umlaut	Y Y	" "	•						•
Ž	Z acute	Z Z	' ı			•				
Ž	Z hacek	Z Z Z	∨ V v			•				
Ž	Z dot above	Z	. Z			•				

**Table 1 Display Menu Setup Parameters, Continued**

Parameter	Explanation
Autopage	When the cursor reaches the top or bottom of the page,
Off	It wraps on the page or the data scrolls, depending on the setting of the Autoscr1 parameter (General menu)
On <sup>1</sup>	A new page of memory moves onto the screen
Scrn Saver	If the terminal receives no data from the keyboard or from the host for approximately 15 minutes, the screen display
On <sup>3</sup>	Turns off
Off	Remains on
Char Cell <sup>4</sup>	The terminal displays a character cell 10 pixels wide and
10x15	15 pixels high (70 Hz refresh)
10x13	13 pixels high (80 Hz refresh)
10x16	16 pixels high (70 Hz refresh)
80/132 Clr	When executing a command to change the number of columns, the terminal
Off	Doesn't clear the screen
On <sup>1</sup>	Clears the screen

1. Not supported in the default Wyse 50 personality.
2. When page format is changed, the terminal clears the entire display memory, homes the cursor, and resets the scroll margin.
3. Press **[Shift]** to restore screen display.
4. Selections show character cell dimensions for 80-column, 24/25-line screen. For a 132-column screen, the corresponding dimensions are 9x15, 9x13, or 9x16. The selections have no effect when the terminal is set for 42/43 lines.

**Table 2 General Menu Setup Parameters**

Parameter	Explanation
Personality <sup>1</sup>	The terminal can run programs using command sets characteristic of the following terminals:
Wyse 50	Wyse WY-50
Wyse 50+	Wyse WY-50+
Wyse 60	Wyse WY-60
Wyse 120+	Wyse WY-120ES, WY-120
Wyse 120	Wyse WY-120
Wyse 150+	Wyse WY-150ES, WY-150
Wyse 150	Wyse WY-150
TVI 910+	TeleVideo 910 and 910+
TVI 925	TeleVideo 925
TVI 905	TeleVideo 905
PC Term	PC terminal
ADDS A2	ADDS Viewpoint A2
HZ 1500	Hazeltine 1500
VT 52	Digital Equipment VT 52
VT 100	Digital Equipment VT 100
VT 220-7	Digital Equipment VT 220, 7-bit mode
VT 220-8	Digital Equipment VT 220, 8-bit mode
UNIX Consol	UNIX terminal
Scrl <sup>2</sup>	The screen display scrolls at
Jump	The rate data is received
Smth-8	Eight lines per second
Smth-4	Four lines per second
Smth-2	Two lines per second
Smth-1	One line per second
Rcv CR	Normally, when the terminal receives an ASCII CR (carriage return) character, the cursor moves to the beginning of the
CR	Current line
CRLF	Next line

*If you change the terminal's personality, exit and reenter setup mode before changing other parameter settings.*

**Table B-7 Compose Character Sequences: Multinational Mode (ANSI Personalities), Continued**

Comp. Char.	Description	Sequence		Multi-national	ISO Latin-1	ISO Latin-2	ISO Latin-5	ISO Cyrillic	Cyrillic	Turkish
		3-Key <sup>1</sup>	2-Key <sup>2</sup>							
Ñ	N tilde	N ~	~ N	•	•		•			•
Ň	N hacek	N ˇ N V N v	ˇ N			•				
Ń	N acute	N ´ N ˆ	ˆ N			•				
Ô	O grave	O `	` O	•	•		•			•
Ó	O acute	O ´ O ˆ	ˆ O	•	•	•	•			•
Ő	O double acute	O ˝	˝ O			•				
Ô	O circumflex	O ^	^ O	•	•	•	•			•
Ö	O umlaut	O ¨ O ˆ	¨ O	•	•	•	•			•
Õ	O tilde	O ~	~ O	•	•		•			•
Œ	OE ligature	O E		•						•
Ø	O slash	O /		•	•		•			•
Ř	R acute	R ´ R ˆ	ˆ R			•				
Ř	R hacek	R ˇ R V R v	ˇ R			•				
Ś	S acute	S ´ S ˆ	ˆ S			•				
Ş	S cedilla	S ,	, S			•	•			•

Table B-7 Compose Character Sequences: Multinational Mode (ANSI Personalities), Continued

Comp. Char.	Description	Sequence		Multi-national	ISO Latin-1	ISO Latin-2	ISO Latin-5	ISO Cyrillic	Cyrillic	Turkish
		3-Key <sup>1</sup>	2-Key <sup>2</sup>							
È	E grave	E `	` E	•	•		•			•
É	E acute	E ' / E ' /	' E	•	•	•	•			•
Ê	E circumflex	E ^	^ E	•	•		•			•
Ë	E umlaut	E " / E "	" E	•	•	•	•	•		•
Ě	E ogonek	E . / E C / E c	. E			•				
Ě	E hacek	E ˇ / E V / E v	ˇ E			•				
Ĝ	G breve	G -	- G				•			•
Ì	I grave	I `	` I	•	•		•			•
Í	I acute	I ' / I ' /	' I	•	•	•	•			•
Î	I circumflex	I ^	^ I	•	•	•	•			•
Ï	I umlaut	I " / I "	" I	•	•		•	•		•
İ	I dot above	I .	. I				•			•
Ĺ	L acute	L ' / L ' /	' L			•				
Ľ	L hacek	L ˇ / L V / L v	ˇ L			•				
Ł	L with stroke	L /	/			•				

Table 2 General Menu Setup Parameters, Continued

Parameter	Explanation
Enhance	In some terminal personalities, an enhanced set of codes is
Off	Not recognized by the terminal
On	Recognized by the terminal
Autoscr	When the cursor moves past the last line of the page,
On	The data scrolls up one line
Off	The cursor returns (wraps) to the top of the same page
Monitor	The terminal
Off	Executes escape sequences and control codes
On	Displays symbols for escape sequences and control codes without acting on them
Status Line	The screen displays
On	A status line with terminal status messages
Off	No status line
Wrap EOL	When characters are entered at the end of a line,
On	The cursor wraps to the start of the next line
Off	Characters at the cursor position are replaced (overwritten)
Recognize DEL	An ASCII DEL character received by the terminal is
Off	Ignored
On <sup>3</sup>	Interpreted as a <i>destructive backspace</i> (character to left of cursor deleted and cursor moved left one position)

1. When you change the personality, the terminal might clear the display memory and force standard settings for other setup parameters—exit and reenter setup mode before making other setup changes.
2. If smooth scrolling is selected, receive handshaking should be enabled (Comm menu).
3. Not supported in the default Wyse 50 personality.

Parameter	Explanation
Keyclick	Each time a key is pressed or repeated, the terminal's bell
On	Sounds a beep
Off	Makes no sound
Keylock	When <b>[Caps Lock]</b> ( <b>[Lock]</b> ) is engaged,
Caps	Alphabetic keys generate only uppercase characters (number and symbol keys are unaffected)
Reverse	The action of <b>[Shift]</b> is reversed: shifted alphabetic keys generate lowercase characters, unshifted alphabetic keys generate uppercase characters (number and symbol keys are unaffected)
Shift	All keys (alphabetic, number, and symbol keys) generate shifted characters only
Repeat	When held down for more than half a second, the keys
On	Repeat
Off	Don't repeat
Language	Choose the setting that matches your keyboard language
Keycode <sup>1</sup>	When keys are pressed, the terminal sends
ASCII	Standard ASCII key codes
Scan <sup>2</sup>	PC scan codes

Comp. Char.	Description	Sequence		Multi-national	ISO Latin-1	ISO Latin-2	ISO Latin-5	ISO Cyrillic	Cyrillic	Turkish
		3-Key <sup>1</sup>	2-Key <sup>2</sup>							
À	A grave	A `	` A	•	•		•			•
Á	A acute	A ´	´ A	•	•	•	•			•
Â	A circumflex	A ^	^ A	•	•	•	•			•
Ã	A tilde	A ~	~ A	•	•		•			•
Ä	A umlaut	A ¨	¨ A	•	•	•	•			•
Å	A ring	A °	° A	•	•		•			•
Æ	AE ligature	A E		•	•		•			•
Ą	A ogonek	A ˆ	ˆ A			•				
Ă	A breve	A ˘	˘ A			•				
Ç	C cedilla	C ,	, C	•	•	•	•			•
Ć	C acute	C ´	´ C			•				
Č	C hacek	C ˇ	ˇ C			•				
Ð	D with stroke, Capital Icelandic Eth	D –			•	•				
Đ	D hacek	D ˇ	ˇ D			•				

### Composing Characters in Multinational Mode (ANSI Personalities)

In UNIX Console personality, do not refer to Table B-7. Refer to Table B-5 instead.

In multinational mode, the characters you can compose depend on the user-preferred supplemental character set (UPSS) setting of the Char Set setup parameter (ANSI 1 menu). Table B-7 lists all the composable characters and identifies which UPSS character set(s) support each character.

You can compose characters with a two-or three-key sequence in any keyboard language.

- Two-key sequences are supported in all keyboard languages that contain the specific nonspacing diacritical mark that introduces the sequence.
- Three-key sequences are supported in all keyboard languages when the Corner Key setup parameter (Keyboard menu) is set to *compose*.

To compose a character,

- 1 Find the character you want to compose in the first column of the table.
- 2 Make sure it is available for your current UPSS set.
- 3 Refer to the third column for the two-key or three-key sequence that composes the character.

To compose the character with a two-key sequence, enter the two characters shown under “2-Key” in the order shown.

For example, to compose *à* when Char Set is set to *Multinational*, press  first and then .

To compose the character with a three-key sequence, first press and release  (   *left*), then enter the two characters shown under “3-Key” in any order.



For example, to compose *à* with a three-key sequence when Char Set is set to *Multinational*, press and release  (   *left*), then press  and  in any order.

**Table 3 Keyboard Menu Setup Parameters, Continued**

Parameter	Explanation	
Corner Key <sup>3</sup>	Pressing the corner key	
<b>Funct</b>	With an alphanumeric key sends an ASCII SOH, the alphanumeric key's ASCII code, and an ASCII CR	
Hold	Freezes the current data on the screen until the key is pressed again	
Compose <sup>4</sup>	In sequence with certain other keys, composes nonstandard characters	
Meta	With an alphanumeric key, sends the other key's code with the high bit set	
Kpd Compose	With one or more keys on the numeric keypad, sends the hexadecimal equivalent of the decimal number entered	
Alt Legend <sup>5</sup>	With certain other keys, selects the alternate character shown on the right side or front face of the key on some <i>international keyboards</i>	
Codepg <sup>6,7</sup>	The terminal displays 8-bit characters from the selected PC character set:	
PC Wyse ASCII <sup>8</sup>	PC Norwegian	PC Cyrillic
PC Multinat'l	PC Spanish	PC Turkish
PC Multilingual	PC Portuguese	PC Polish
PC Fr/Canadian	PC Slavic	
ASCII <sup>9</sup>	The terminal displays 8-bit characters	
<b>National 7-bit</b> <sup>10</sup>	As 7-bit national replacement characters according to the selected keyboard language	
Multinational <sup>11</sup>	From the 8-bit character set selected by the Codepg setup parameter	
ASCII Font <sup>12,13</sup>	The terminal displays 7-bit characters from the ASCII character set containing line-drawing control characters	
WY ASCII <sup>14</sup>		
PC Standard	True PC code page character set	

**Table 3 Keyboard Menu Setup Parameters, Continued**

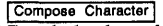
Parameter	Explanation
Down Key <sup>15</sup>	When  is pressed, the cursor moves down one line in the current column. When the cursor attempts to move past the last line of the page, the data
CTRL V	Remains fixed and the cursor stops at the last line of the page
CTRL J	Normally scrolls up, deleting the first line of the page and creating a new line at the bottom of the page

1. If Comm parameter is set to *BLK*, *HBLK*, or *local*, the terminal sends ASCII key codes regardless of the setting of this parameter.
2. Not supported in the default Wyse 50 personality.
3.  on the ASCII keyboard,  on the 105-Key ANSI keyboard, and  on the Enhanced PC-style keyboard.
4. Entering an ANSI personality forces *compose* as the default setting.
5. Selection applies only to 105-Key ANSI international keyboards and International Enhanced PC-style keyboards.
6. Parameter available only in the following personalities, and then only if the terminal is in multinational mode (ASCII parameter set to *multinational*): Wyse 60, Wyse 120, Wyse 120+, Wyse 150, Wyse 150+, PC Term, and UNIX Console.
7. Entering PC Term or UNIX Console personality forces a selection appropriate for the keyboard language. Once in the personality, any character set can be selected.
8. Selection forced on entering Wyse 60, Wyse 120, Wyse 120+, Wyse 150, or Wyse 150+ personality from any other personality. Once in the personality, any character set can be selected. The selection is not supported in PC Term or UNIX Console personality.
9. Parameter available only in the following personalities: Wyse 60, Wyse 120, Wyse 120+, Wyse 150, Wyse 150+, PC Term.
10. Selection forced on entering Wyse 60, Wyse 120, Wyse 120+, Wyse 150, or Wyse 150+ personality from any other personality. Once in the personality, *multinational* can be selected.
11. Selection forced on entering PC Term personality. Once in the personality, *national 7-bit* can be selected.
12. Ignored in PC Term personality.
13. Parameter available only in the following personalities, and then only if the terminal is in multinational mode (ASCII parameter set to *multinational*): Wyse 60, Wyse 120, Wyse 120+, Wyse 150, Wyse 150+.
14. Selection forced on entering Wyse 60, Wyse 120, Wyse 120+, Wyse 150, or Wyse 150+ personality from any other personality. Once in the personality, the PC Standard character set can be selected.
15. TVI 905 personality only.

**Table B-6 Compose Character Sequences: National Mode (ANSI Personalities), Continued**

Composed Character	Description	3-Key Sequence <sup>1</sup>	2-Key Sequence <sup>2</sup>	Composed Character	Description	3-Key Sequence <sup>1</sup>	2-Key Sequence <sup>2</sup>
<b>French Canadian Keyboard</b>							
à	a grave	` a	` a	î	i circumflex	^ i	^ i
â	a circumflex	^ a	^ a	ô	o circumflex	^ o	^ o
è	e grave	` e	` e	ù	u grave	` u	` u
é	e acute	' e	' e	û	u circumflex	^ u	^ u
ê	e circumflex	^ e	^ e	ç	c cedilla	, c	
<b>Latin American Keyboard</b>							
á	a acute	' a	' a	ñ	n tilde	~ n	
é	e acute	' e	' e	ú	u acute	' u	
í	i acute	' i	' i	ü	u umlaut	~ u	
<b>Portuguese Keyboard</b>							
'	Apostrophe	'	SP	ã	a tilde	a ~	~ a
Ã	A tilde	A ~	~ A	õ	o tilde	o ~	~ o
Õ	O tilde	O ~	~ O				
<b>Spanish Keyboard</b>							
£	Pound <sup>3</sup>	L -		§	Section	Q S	
		L =				! S	
°	Degree	^ 0					
<b>Swedish Keyboard</b>							
Û	U umlaut	" U		É	E acute	' E	
ü	u umlaut	" u		é	e acute	' e	
<b>Swiss (French/German) Keyboard</b>							
ê	e circumflex	^ e	^ e	ù	u grave	` u	` u
î	i circumflex	^ i	^ i	û	u circumflex	^ u	^ u
ô	o circumflex	^ o	^ o				

1. First press the corner key. The other two keys can be pressed in any order.
2. Any sequence in this column can also be used to compose a three-key sequence. The difference is that for a two-key sequence, the two keys must be pressed in the order shown in this column; for a three-key sequence, you must first press the corner key, but the two keys can be pressed in any order.
3. Alphabetic keys can be entered in uppercase or lowercase.

5 Enter the two characters from the column that lists the three-key sequence. The two characters can be entered in any order.

For example, to compose à on the French Canadian keyboard, press and release **[Funct]** (**[Compose Character]**, **[Alt left]**), then press **[ ]** and **[a]** in any order.

To compose a character with a two-key sequence,

- 1 Find your keyboard language in Table B-6.
- 2 Find the character you want to compose in the “Composed Character” column of the table.
- 3 If there is a two-key sequence, and your keyboard language supports the indicated diacritical mark (see Tables B-1, B-2, and B-3), enter the characters *in the order shown*.

For example, to compose à on the French Canadian keyboard, press **[ ]** first and then **[a]**.

**Table B-6 Compose Character Sequences: National Mode (ANSI Personalities)**

Composed Character	Description	3-Key Sequence <sup>1</sup>	2-Key Sequence <sup>2</sup>	Composed Character	Description	3-Key Sequence <sup>1</sup>	2-Key Sequence <sup>2</sup>
<b>Dutch Keyboard</b>							
¼	One-fourth <sup>2</sup>	1 4		ij	ij sign <sup>2</sup>	i j	
½	One-half <sup>2</sup>	1 2		f	Florin <sup>2</sup>	f -	
'	Acute accent	' '			Vertical line	/ ^	
¾	Three-fourths <sup>2</sup>	3 4		¨	Diaeresis (umlaut)	" ^	
<b>Finnish Keyboard</b>							
é	e acute	' e					
<b>French/Belgian/Flemish Keyboard</b>							
£	Pound <sup>3</sup>	L -					
		L =					

**Table 4 COMM Menu Setup Parameters**

Parameter	Explanation
Comm	The terminal's communication mode is
FDX	Full-duplex
BLK	Block
HDX <sup>1</sup>	Half-duplex
HBLK	Half-duplex block
Local	Local
Mdm Rc Hsk	The terminal controls the receipt of data from a device connected to the Modem port by
None	No handshaking protocol
XON-XOFF/XPC <sup>2</sup>	XON/XOFF or XPC software handshaking
DTR	DTR hardware handshaking (raising and lowering the voltage on the DTR line)
Both <sup>2</sup>	Both hardware and software handshaking
Aux Rc Hsk	The terminal controls the receipt of data from a device connected to the Aux port by
None	No handshaking protocol
XON-XOFF/XPC <sup>2</sup>	XON/XOFF or XPC software handshaking
DSR	DSR hardware handshaking (raising and lowering the voltage on the DSR line)
Both <sup>2</sup>	Both hardware and software handshaking
Xmt Lim	The terminal sends data through the host port
None	As fast as the baud rate allows
35 cps	At a maximum 35 characters per second
60 cps	At a maximum 60 characters per second
150 cps	At a maximum 150 characters per second
Mdm Rc Hsk Level	If receive handshaking is active, the terminal handshakes through the host port when
192	192 characters are in the buffer
128	128 characters are in the buffer
64	64 characters are in the buffer

**Table 4 COMM Menu Setup Parameters, Continued**

Parameter	Explanation
Send ACK On	After executing certain commands, the terminal sends an ASCII ACK character to the host port when the operation is complete
Off	Sends no acknowledgment
Answerback Mode Off	In response to an ASCII ENQ character, the terminal sends no answerback message
On	Automatically sends the answerback message to the host (see "Defining an Answerback Message")
Mdm Xmt Hsk <sup>3</sup> None <sup>4</sup>	When sending data to a device connected to the Modem port, the terminal ignores all incoming software handshaking codes
XON-XOFF	Responds to XON/XOFF software handshaking and DSR hardware handshaking
Aux Xmt Hsk <sup>3</sup> None <sup>4</sup>	When sending data to a device connected to the Aux port, the terminal ignores all incoming software handshaking codes
XON-XOFF	Responds to XON/XOFF software handshaking and DTR hardware handshaking

1. Don't select this setting unless you know it is required; duplicated characters will appear on the screen if the host also echoes the data. Setting is invalid if Keycode parameter is set to *scan*.
2. Software handshaking is XON-XOFF if Keycode parameter is set to *ASCII*, XPC if Keycode parameter is set to *scan*.
3. Don't change the default setting (*none*) unless another setting is specifically required by your system installation. Set to XON-XOFF to be fully DEC-compatible when the terminal is in an ANSI personality.
4. Terminal always responds to hardware handshaking if port is configured as printer port.

**Table B-5 Compose Character Sequences: Multinational Mode (ASCII Personalities); Continued**

Comp. Char.	Description	Sequence		PC Multi-nat.	PC Multi-ling.	PC Fr. Can.	PC Norw.	PC Span.	PC Port.	PC Slav.	PC Cyril.	PC Turk.	PC Pol.
		3-Key <sup>1</sup>	2-Key <sup>2</sup>										
}	Right brace	)	-	•	•	•	•	•	•	•	•	•	•
~	Tilde	~ SP	~ SP	•	•	•	•	•	•	•	•	•	•

1. First press the corner key. The other two keys can be pressed in any order.
2. Any sequence in this column can also be used to compose a 3-key sequence. The difference is that for a 2-key sequence, the two keys must be pressed in the order shown in this column; for a 3-key sequence, you must first press the corner key, but the two keys can be pressed in any order.
3. Alphabetic characters can be entered in uppercase or lowercase.
4. Available only in the following keyboard languages: Czech, Hungarian, Polish, Romanian, Slovak, SCS, Turkish, and Russian.
5. Not available in the following keyboard languages: Czech, Hungarian, Polish, Romanian, Slovak, SCS, Turkish, and Russian.

**COMPOSING CHARACTERS IN ANSI PERSONALITIES**

You can compose characters in national mode in all ANSI personalities except UNIX Console.

In multinational mode, you can compose characters in VT220 and UNIX Console personalities only.

- Note** Because UNIX Console personality, unlike other ANSI personalities, displays characters from PC character sets, refer to Table B-5 for the characters you can compose.

**Composing Characters in National Mode (ANSI Personalities)**

In national mode, the characters you can compose depend on your keyboard language.

Table B-6 lists the characters you can compose in each keyboard language. Only the characters that you might want to compose are listed—that is, characters that don't already appear on your keyboard.

To compose a character with a three-key sequence,

- 1 Set the Corner Key setup parameter to *compose*.
- 2 Find your keyboard language in Table B-6.
- 3 Find the character you want to compose in the "Composed Character" column of the table.
- 4 Press and release **[Funct]** **[Compose Character]**, **[Alt left]**.



**Table B-5 Compose Character Sequences: Multinational Mode (ASCII Personalities), Continued**

Comp. Char.	Description	Sequence		PC Multi-nat.	PC Multi-ling.	PC Fr. Can.	PC Norw.	PC Span.	PC Port.	PC Slav.	PC Cyril.	PC Turk.	PC Pol.
		3-Key <sup>1</sup>	2-Key <sup>2</sup>										
f	Florin	f	-	•	•	•	•						•
©	Copyright <sup>3</sup>	C O C Ø			•							•	
®	Registered trademark <sup>3</sup>	R O			•							•	
µ	Micro <sup>3</sup>	/ U		•	•	•	•	•	•			•	•
¬	Logical not	- ,		•	•	•	•		•			•	•
"	Quotation mark	" SP " SP		•			•	•	•		•		•
#	Number/pound	+ +		•	•	•	•	•	•	•	•	•	•
'	Apostrophe	' SP ' SP <sup>5</sup>		•	•	•	•	•	•	•	•	•	•
@	At <sup>3</sup>	A A		•	•	•	•	•	•	•	•	•	•
`	Grave accent	` SP ` SP		•	•	•	•	•	•	•	•	•	•
[	Left bracket	( (		•	•	•	•	•	•	•	•	•	•
/	Backslash	/ / / <		•	•	•	•	•	•	•	•	•	•
]	Right bracket	) )		•	•	•	•	•	•	•	•	•	•
^	Circumflex	^ SP ^ SP		•	•	•	•	•	•	•	•	•	•
{	Left brace	( -		•	•	•	•	•	•	•	•	•	•
	Vertical line	/ ^ ^ /		•	•	•	•	•	•	•	•	•	•

**Table 5 Ports Menu Setup Parameters**

Parameter	Explanation
Mdm Baud Rate	The Modem port baud rate (rate at which data is transmitted and received) is
9600	57600 75 150 1200 4800
19200	115200 110 300 1800
38400	50 134.5 600 2400
Aux Baud Rate	The Aux port baud rate (rate at which data is transmitted and received) is
9600	57600 75 150 1200 4800
19200	115200 110 300 1800
38400	50 134.5 600 2400
Host Port	The terminal communicates with the host through the
Modem Port	Modem port
Aux Port	Aux port
Mdm Data/Parity	The terminal sends data through the Modem port with
8/None	8-bit data, no parity
8/Space	8-bit data, space parity
8/Odd	8-bit data, odd parity
8/Even	8-bit data, even parity
8/Mark	8-bit data, mark parity
7/None	7-bit data, no parity
7/Space	7-bit data, space parity
7/Odd	7-bit data, odd parity
7/Even	7-bit data, even parity
7/Mark	7-bit data, mark parity

**Table 5 Ports Menu Setup Parameters, Continued**

Parameter	Explanation
Aux Data/Parity	The terminal sends data through the Aux port with
8/None	8-bit data, no parity
8/Space	8-bit data, space parity
8/Odd	8-bit data, odd parity
8/Even	8-bit data, even parity
8/Mark	8-bit data, mark parity
7/Space	7-bit data, space parity
7/Odd	7-bit data, odd parity
7/Even	7-bit data, even parity
7/Mark	7-bit data, mark parity
7/None	7-bit data, no parity
Printer Attached	When a print command is received by the terminal, the terminal
On	Sends incoming data to the Aux port
Off	Ignores the print command
Serial <sup>1</sup>	Sends incoming data to the Aux port
Parallel <sup>1</sup>	Sends incoming data to the Parallel port
None <sup>1</sup>	Ignores the print command
Mdm Stop Bits	The terminal sends and receives characters through the Modem port with
1	1 stop bit
2	2 stop bits
Aux Stop Bits	The terminal sends characters through the Aux port with
1	1 stop bit
2	2 stop bits

**Table B-5 Compose Character Sequences: Multinational Mode (ASCII Personalities), Continued**

Comp. Char.	Description	Sequence		PC Multi-nat.	PC Multi-ling.	PC Fr. Can.	PC Norw.	PC Span.	PC Port.	PC Slav.	PC Cyril.	PC Turk.	PC Pol.
		3-Key <sup>1</sup>	2-Key <sup>2</sup>										
<<	Left angle brackets	<	<	•	•	•	•	•	•	•		•	•
>>	Right angle brackets	>	>	•	•	•		•	•	•		•	•
±	Plus or minus	+	-	•	•	•	•	•	•			•	•
+	Division sign	-	:	•	•	•	•	•	•	•		•	•
×	Multiplication sign	x	x		•					•		•	
<sup>1</sup>	Superscript 1	1	^ 1		•							•	
<sup>2</sup>	Superscript 2	2	^ 2	•	•	•	•	•	•			•	•
<sup>3</sup>	Superscript 3	3	^ 3		•	•						•	
½	One-half	1	2	•	•	•	•	•	•			•	•
¼	One-fourth	1	4	•	•	•	•	•	•			•	•
¾	Three-fourths	3	4		•	•						•	
	Broken bar	!	^ !		•	•						•	
ª	Feminine ordinal <sup>3</sup>	A	-	•	•		•	•	•			•	
º	Masculine ordinal <sup>3</sup>	O	-	•	•		•	•	•			•	
§	Section <sup>3</sup>	S	!		•	•				•		•	•
		S	O										
		S	0										
¶	Paragraph <sup>3</sup>	P	!		•	•						•	

**Table B-5 Compose Character Sequences: Multinational Mode (ASCII Personalities), Continued**

Comp. Char.	Description	Sequence		PC Multi-nat.	PC Multi-ling.	PC Fr. Can.	PC Norw.	PC Span.	PC Port.	PC Slav.	PC Cyril.	PC Turk.	PC Pol.
		3-Key <sup>1</sup>	2-Key <sup>2</sup>										
¢	Cent <sup>3</sup>	C / C		•	•	•			•			•	
¥	Yen <sup>3</sup>	Y - Y =		•	•							•	•
¡	Inverted exclamation mark	! !		•	•		•	•	•			•	•
¿	Inverted question mark	? ?		•	•		•	•	•			•	
-	Soft hyphen (SHY)	- -			•	•				•		•	
´	Acute accent	´ ´ ´ ´	´ ´ ´ ´ SP <sup>4</sup>		•	•				•		•	
¨	Double acute	¨ ¨ ¨ ¨	¨ ¨ ¨ ¨ SP							•			
ˆ	Ogonek		ˆ SP									•	
¸	Cedilla	, , , ,	, SP		•	•				•		•	
ˇ	Hacek		ˇ SP							•			
˘	Breve		˘ SP							•		•	
°	Ring or degree	0 ^ SP * SP o	^ 0 ° SP	•	•	•	•	•	•	•	•	•	•
¨	Umlaut	¨ ¨ ¨ ¨	¨ ¨ ¨ SP		•	•				•		•	
-	Macron	- ^ - ^	^ - ^ -		•								
.	Middle dot	^ . ^ .	^ .	•	•	•	•	•	•	•	•	•	•

**Table 5 Ports Menu Setup Parameters, Continued**

Parameter	Explanation
Nulls Suppress	When receiving data from the host to be passed to the printer port, the terminal
<b>On</b>	Strips incoming null characters
<b>Off<sup>2</sup></b>	Processes null characters as valid data

1. ES models only. *Serial* is the default for ES models.
2. Not supported in the default Wyse 50 personality.

**Table 6 Miscellaneous Menu Setup Parameters**

Parameter	Explanation
WPRT Intensity	Write-protected characters appear
<b>Dim</b>	Dim
<b>Dim/Inv<sup>1</sup></b>	Dim and invisible
<b>Normal</b>	Normal
<b>Blank<sup>1</sup></b>	Invisible
Blk End	When the terminal sends a block of data to the host, the
<b>US/CR</b>	Line terminator is an ASCII US character; block terminator is an ASCII CR character
<b>CRLF/ETX</b>	Line terminators are the ASCII CR and LF characters; block terminator is an ASCII ETX character
Margin Bell	The terminal's bell
<b>Off</b>	Is silent when the cursor approaches the right margin
<b>On</b>	Rings when the cursor reaches the column where the bell is set (default is column 72 in 80-column mode, column 124 in 132-column mode)



**Table B-5 Compose Character Sequences: Multinational Mode (ASCII Personalities), Continued**

Comp. Char.	Description	Sequence		PC Multi-nat.	PC Multi-ling.	PC Fr. Can.	PC Norw.	PC Span.	PC Port.	PC Slav.	PC Cyril.	PC Turk.	PC Pol.
		3-Key <sup>1</sup>	2-Key <sup>2</sup>										
ò	o grave	o `	` o	•	•		•	•	•			•	
ó	o acute	o ' / o '	' o / ' o	•	•	•	•	•	•	•		•	•
ô	o circumflex	o ^	^ o	•	•	•	•	•	•	•		•	•
ö	o umlaut	o " / o "	" o / " o	•	•		•	•		•		•	•
õ	o tilde	o ~	~ o		•				•			•	
ø	o slash	o /			•		•					•	
ř	r acute	r ' / r '	' r / ' r							•			
ř	r hacek	r ˇ / r ˇ v	ˇ r / ˇ r v							•			
š	s acute	s ' / s '	' s / ' s							•			•
š	s cedilla	s ,	, s							•		•	
š	s hacek	s ˇ / s ˇ v	ˇ s / ˇ s v							•			
ť	t hacek	t ˇ / t ˇ v	ˇ t / ˇ t v							•			
ţ	t cedilla	t ,	, t							•			
ù	u grave	u `	` u	•	•	•	•	•	•			•	•
ú	u acute	u ' / u '	' u / ' u	•	•	•	•	•	•	•		•	•

**Table 6 Miscellaneous Menu Setup Parameters, Continued**

Parameter	Explanation
Rest/Act. Times	After a period of keyboard activity, the terminal's bell
None	Doesn't signal any rest period
5/30	Signals a 5-minute rest after 30 minutes of activity
10/30	Signals a 10-minute rest after 30 minutes of activity
10/60	Signals a 10-minute rest after 60 minutes of activity
15/60	Signals a 15-minute rest after 60 minutes of activity
15/120	Signals a 15-minute rest after 120 minutes of activity
30/120	Signals a 30-minute rest after 120 minutes of activity

1. Not supported in the default Wyse 50 personality.
2. Supported only in hidden attribute personalities (Wyse 60, Wyse 120+, Wyse 120, Wyse 150+, Wyse 150, PC Term, VT 52, VT 100, VT 220, and UNIX Console).
3. Page is the default setting in nonhidden attribute personalities (Wyse 50, Wyse 50+, TVI 910+, TVI 925, TVI 905, ADDS A2, HZ 1500).

**Table 7 ANSI 1 Menu Setup Parameters<sup>1</sup>**

Parameter	Explanation
Char Set	The user-preferred supplemental character set (UPSS) is
<b>Multinational</b>	Multinational Supplemental
ISO Latin-1	ISO 8859/1, Latin Alphabet Number 1
ISO Latin-2	ISO 8859/2, Latin Alphabet Number 2
ISO Cyrillic Cyrillic	ISO 8859/5, Cyrillic Cyrillic
ISO Latin-5	ISO 8859/9, Latin Alphabet Number 5
Turkish	Turkish

Parameter	Explanation
Cursor Keys	The cursor keys send
<b>Normal</b>	Normal cursor movement commands
<b>Application</b>	Application-specific control codes and escape sequences
Feature Lock <sup>2</sup>	User preference features
<b>Off</b>	Can be redefined by host application programs
<b>On</b>	Are locked so that they cannot be redefined by the host
Char Mode	The terminal displays 8-bit characters
<b>Multinational</b>	From the 8-bit character set selected by the Char Set parameter
<b>National</b>	As 7-bit national replacement characters according to the selected keyboard language
Keypad	Numeric keypad keys send
<b>Numeric</b>	Numeric or other codes according to the characters on the keycaps
<b>Application</b>	Application-specific control codes and escape sequences
Fkey Lock	Redefinable function key definitions
<b>Off</b>	Can be redefined by host application programs
<b>On</b>	Cannot be redefined by host application programs
ANSI ID	In answer to a host request, the terminal identifies itself as a
<b>VT 100</b>	VT 100-type terminal
<b>VT 101</b>	VT 101-type terminal
<b>VT 102</b>	VT 102-type terminal
<b>VT 220</b>	VT 220-type terminal

Comp. Char.	Description	Sequence		PC Multi-nat.	PC Multi-ling.	PC Fr. Can.	PC Norw.	PC Span.	PC Port.	PC Slav.	PC Cyril.	PC Turk.	PC Pol.
		3-Key <sup>1</sup>	2-Key <sup>2</sup>										
ę	e ogonek	e ˘ e c	˘ e							•			•
ě	e hacek	e ˇ e v	ˇ e							•			
ğ	g breve	g ˘	˘ g									•	
ï	i grave	i `	` i	•	•		•	•	•			•	
í	i acute	i ´	´ i	•	•		•	•	•	•		•	
î	i circumflex	i ^	^ i	•	•	•	•	•		•		•	•
ï	i umlaut	i ¨ i "	¨ i	•	•	•	•	•			•	•	•
ı	i without dot	ı	ı									•	
ł	l geminada	ł ł *						•					
ĺ	l acute	ĺ ĺ ´	´ l							•			
ľ	l hacek	ľ ľ ˇ	ˇ l							•			
ł	l with stroke	ł /								•			•
ñ	n tilde	n ~	~ n	•	•		•	•	•			•	
ň	n hacek	ň ň ˇ	ˇ n							•			
ń	n acute	ń ń ´	´ n							•			•

**Table B-5 Compose Character Sequences: Multinational Mode (ASCII Personalities), Continued**

Comp. Char.	Description	Sequence		PC Multi-nat.	PC Multi-ling.	PC Fr. Can.	PC Norw.	PC Span.	PC Port.	PC Slav.	PC Cyril.	PC Turk.	PC Pol.
		3-Key <sup>1</sup>	2-Key <sup>2</sup>										
ä	a umlaut	a ¨ a "	¨ a	•	•		•	•		•		•	•
å	a ring	a ° a *	° a	•	•		•					•	
æ	ae ligature	a e		•	•		•					•	
ą	a ogonek	a ˙ a c	˙ a							•			•
ā	a breve	a ˘ a u	˘ a							•			
ç	c cedilla	c ¸ c ,	, c	•	•	•	•	•	•	•		•	•
é	e acute	c / c	/ c							•			•
č	c hacek	c ˇ c v	ˇ c							•			
đ	d with stroke	d ˚								•			
ð	Small Icelandic Eth	d -			•								
ď	d hacek	d ˇ d v	ˇ d							•			
è	e grave	e `	` e	•	•	•	•	•	•			•	•
é	e acute	e / e	/ e	•	•	•	•	•	•	•		•	•
ê	e circumflex	e ^	^ e	•	•	•	•	•	•			•	•
ë	e umlaut	e ¨ e "	¨ e	•	•	•	•	•		•	•	•	•

**Table 7 ANSI 1 Menu Setup Parameters<sup>1</sup>, Continued**

Parameter	Explanation
DEL	The unshifted delete key sends a
DEL/CAN	Delete character (DEL), and the shifted key sends a cancel character (CAN)
BS/DEL	Backspace character (BS), and the shifted key sends a delete character (DEL)
Newline <sup>3</sup>	When <input type="checkbox"/> Return or <input type="checkbox"/> Enter is pressed, the terminal sends
Off	A carriage return code (CR); cursor moves to start of line
On	Both a carriage return code (CR) and a linefeed code (LF); cursor moves to start of next line

- Parameters on this setup menu apply only when the terminal is in VT 220, VT 100, or VT 52 personality.
- User preference features are key repeat, scrolling speed, screen background, tab stops, and keyboard lock. Locking these features might cause problems for an application program that is programmed to control them.
- If a linefeed command (LF, VT, FF) is received from the host when this parameter is set to *off*, the cursor moves down one line in the same column; if the parameter is set to *on*, the cursor moves to the start of the next line.

**Table 8 ANSI 2 Menu Setup Parameters<sup>1</sup>**

Parameter	Explanation
Print	During a print page or print line operation,
ASCII	Escape sequences are not sent and non-ASCII characters are replaced with ASCII underline characters
Line Drawing	Escape sequences and control codes are sent, allowing printing of ASCII and line-drawing graphics characters, and character and line attributes
All	Escape sequences and control codes are sent, allowing printing of all characters and attributes, and providing character set information

Parameter	Explanation
Send <b>All</b>	In block transmissions, Erasable and nonerasable data is sent to the host
<b>Erasable</b>	Only erasable data is sent
Xfer Term <b>EOS</b>	The terminal transmits blocks of data to the host ending at the End of the page or line as defined by the send command
<b>Cursor</b>	Cursor position
Print Area <b>Page</b> <b>Scroll Rgn</b>	In a page print operation, the terminal sends to the printer port the data from the Page Defined scrolling region
Send Area <b>Page</b> <b>Scroll Rgn</b>	In a send page operation, the terminal sends to the host the data from the Page Defined scrolling region
Auto Answerback <b>Off</b> <b>On</b>	At power-on, the terminal Sends no answerback message Automatically sends the answerback message to the host
Print Term <b>None</b> <b>FF</b>	At the end of a page print operation, No terminator character is sent A formfeed character (FF) is sent
Send Term <b>None</b> <b>FF</b>	At the end of a send page operation, No terminator character is sent A formfeed character (FF) is sent

Comp. Char.	Description	Sequence		PC Multi-nat.	PC Multi-ling.	PC Fr. Can.	PC Norw.	PC Span.	PC Port.	PC Slav.	PC Cyril.	PC Turk.	PC Pol.
		3-Key <sup>1</sup>	2-Key <sup>2</sup>										
Ƨ	T cedilla	T , T ;	, T ; T							•			
Ù	U grave	U `	` U		•	•			•			•	
Ú	U acute	U ´ U ¨	´ U ¨ U		•			•	•	•		•	
Û	U umlaut	U ¨ U " "	¨ U " U	•	•	•	•	•	•	•		•	•
Ü	U double acute	U " "	" U							•			
Û	U circumflex	U ^	^ U		•	•						•	
Ů	U ring	U ° U O U o U *	° U O U o U * U							•			
Ý	Y acute	Y ´ Y ¨	´ Y ¨ Y		•					•			
Ž	Z acute	Z ´ Z ¨	´ Z ¨ Z							•			•
Ž	Z hacek	Z ˇ Z V	ˇ Z V Z							•			
Ž	Z dot above	Z .	. Z							•			•
à	a grave	a `	` a	•	•	•	•	•	•			•	•
á	a acute	a ´ a ¨	´ a ¨ a	•	•		•	•	•	•		•	
â	a circumflex	a ^	^ a	•	•	•	•	•	•	•		•	•
ã	a tilde	a ~	~ a		•				•			•	



**Table B-5 Compose Character Sequences: Multinational Mode (ASCII Personalities), Continued**

Comp. Char.	Description	Sequence		PC Multi-nat.	PC Multi-ling.	PC Fr. Can.	PC Norw.	PC Span.	PC Port.	PC Slav.	PC Cyril.	PC Turk.	PC Pol.
		3-Key <sup>1</sup>	2-Key <sup>2</sup>										
Ñ	N tilde	N ~	~ N	•	•		•	•	•			•	
Ň	N hacek	N ˇ N V	ˇ N							•			
Ń	N acute	N ´ N ˆ	´ N							•			•
Ò	O grave	O `	` O		•			•	•			•	
Ó	O acute	O ´ O ˆ	´ O		•			•	•	•		•	•
Ô	O circumflex	O ^	^ O		•	•			•	•		•	
Ö	O umlaut	O ¨ O "	¨ Ö	•	•		•	•		•		•	•
Õ	O tilde	O ~	~ O		•				•			•	
Ø	O slash	O /			•		•					•	
Ř	R acute	R ´ R ˆ	´ R							•			
Ř	R hacek	R ˇ R V	ˇ R							•			
Ś	S acute	S ´ S ˆ	´ S							•			•
Ş	S cedilla	S ¸ S ˘	¸ S							•		•	
Š	S hacek	S ˇ S V	ˇ S							•			
Ť	T hacek	T ˇ T V	ˇ T							•			

**Table 8 ANSI 2 Menu Setup Parameters<sup>1</sup>, Continued**

Parameter	Explanation
Keys	On some international ANSI keyboards, certain keys send codes for
<b>Typewriter</b>	The standard character shown on the left half of the keycap
<b>Data Processing<sup>2</sup></b>	The alternate character shown on the right half of the keycap

- Parameters on this setup menu apply only when the terminal is in VT 220, VT 100, or VT 52 personality.
- Do not select this setting if your keyboard language is one of the following: Czech, Hungarian, Polish, Romanian, Russian, SCS, or Slovak. Setting will not produce the alternate keycap character on these keyboards.

**SETTING TAB STOPS**

At power-on, the terminal clears tab stops by default. However, if you set tab stops and save them, the terminal saves your tab settings in battery-backed memory, where the tab settings remain until you change them.

Figure 4 shows the Tabs menu after three tab stops have been set.

**Figure 4 Tabs Menu**

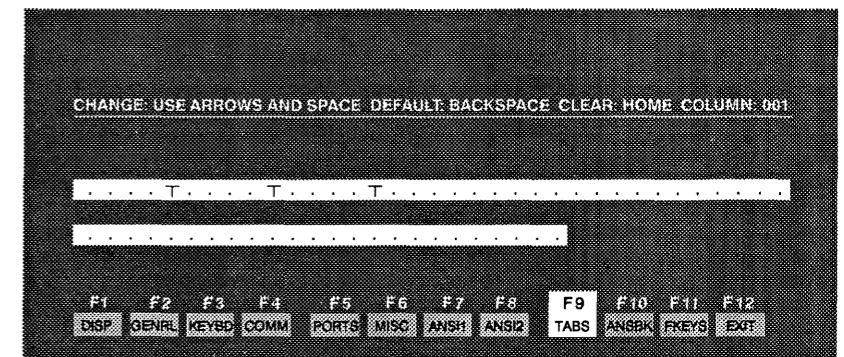

Tab stops are indicated by the letter *T* displayed along a line of periods that mark each column position (as shown in Figure 4). A tab stop in columns

- 2 through 78 is shown as a T in the upper line of periods
- 79 through 132 is shown as a T in the lower line of periods

To determine where tabs are set, press **▶** or **◀** to move the cursor across the line. The current column number is displayed in the *Column:* field at the top of the menu.

You can set and clear tabs in any column except column 1, as follows:

- To move the cursor across the line, press **▶** or **◀**.
- To either set or clear an individual tab stop at the cursor position, press **Spacebar**.
- To clear all tabs, press **Home** (**F14**).
- To set tab stops every eighth column, press **Back Space** (**↵**), **← Back Space**.

To save the tab stops in battery-backed memory, change the highlighted Save? setting in the setup directory to *Yes* or *All* before exiting setup mode.

**DEFINING AN ANSWERBACK MESSAGE**

On the Answerback setup menu you can program a message with a maximum of 20 characters to identify the terminal to the computer. Enter the message at the cursor position. Correct errors by pressing **◀** (**←**) to delete characters or **Home** (**F14**) to clear the message.

- Note** All methods of entering characters from your keyboard in normal operating mode are available in setup mode.

To conceal the answerback message, preventing its display in setup mode, press **Enter** *kpd*. The message is replaced by the word *Concealed* and cannot be redisplayed or modified unless you clear and redefine it.

To save the answerback message in battery-backed memory, change the highlighted Save? setting on the setup directory screen to *All* before exiting setup mode.

*On the Fkeys menu (Figure 5) when Buffer is set to NVR, the answerback message is automatically saved in battery-backed memory.*

**Table B-5 Compose Character Sequences: Multinational Mode (ASCII Personalities), Continued**

Comp. Char.	Description	Sequence		PC Multi-nat.	PC Multi-ling.	PC Fr. Can.	PC Norw.	PC Span.	PC Port.	PC Slav.	PC Cyril.	PC Turk.	PC Pol.
		3-Key <sup>1</sup>	2-Key <sup>2</sup>										
É	E acute	E ' E	' E	•	•	•	•	•	•	•		•	
Ê	E circumflex	E ^ E	^ E		•	•			•			•	
Ë	E umlaut	E " E	" E		•	•				•	•	•	
Ě	E ogonek	E . E	. E							•			•
Ě	E hacek	E ˇ E	ˇ E							•			
Ĝ	G breve	G - G	- G									•	
Ì	I grave	I ` I	` I		•				•			•	
Í	I acute	I ' I	' I		•			•	•	•		•	
Î	I circumflex	I ^ I	^ I		•	•				•		•	
Ï	I umlaut	I " I	" I		•	•		•			•	•	
İ	I dot above	I . I	. I									•	
Ĺ	L geminada	L . L	. L					•					
Ļ	L acute	L ' L	' L							•			
Ľ	L hacek	L ˇ L	ˇ L							•			
Ł	L with stroke	L /	/							•			•

**Table B-5 Compose Character Sequences: Multinational Mode (ASCII Personalities)**

Comp. Char.	Description	Sequence		PC Multi-nat.	PC Multi-ling.	PC Fr. Can.	PC Norw.	PC Span.	PC Port.	PC Slav.	PC Cyril.	PC Turk.	PC Pol.
		3-Key <sup>1</sup>	2-Key <sup>2</sup>										
À	A grave	A `	` A		•	•		•	•			•	
Á	A acute	A ´ A '	' A		•			•	•	•		•	
Â	A circumflex	A ^	^ A		•	•			•	•		•	
Ã	A tilde	A ~	~ A		•				•			•	
Ä	A umlaut	A ¨ A "	" A	•	•		•	•		•		•	•
Å	A ring	A ° A *	* A	•	•		•					•	
Æ	Æ ligature	A E		•	•		•					•	
Ą	A ogonek	A ˆ A C	ˆ A							•			•
Ă	A breve	A ˘	˘ A							•			
Ç	C cedilla	C ¸	¸ C	•	•	•	•	•	•	•		•	•
Č	C hacek	C ˇ C V	ˇ C							•			
Ð	D with stroke, Capital Icelandic Eth	D –			•					•			
Ď	D hacek	D ˇ D V	ˇ D							•			
È	E grave	E `	` E		•	•		•	•			•	

**REDEFINING THE KEYS**

On the Fkeys (function keys) menu (Figure 5), you can redefine the function keys and many of the editing keys, shifted and unshifted, to send a unique character string of up to 64 characters. You can also define a key's *direction*, which determines where the terminal sends the data when the key is pressed.

■ **Caution** Applications that have defined actions for certain keys might not run properly if the keys are redefined.

**Figure 5 Fkeys Menu**

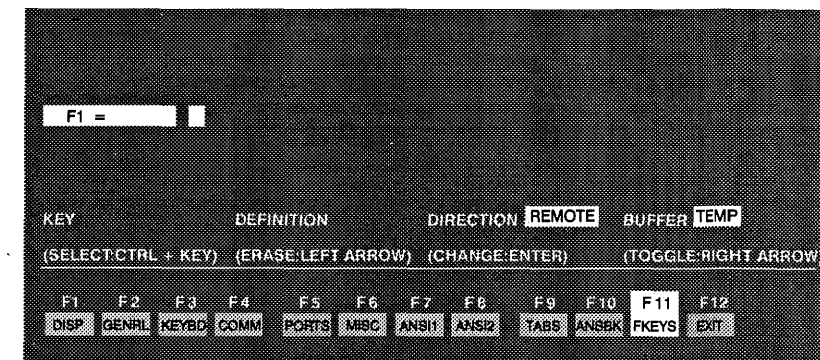

■ **Caution** To avoid possible loss of your key definitions, decide on the Buffer setting *before* entering definitions.

**Example**

This example shows how to define **[Shift] [F7]**, from the Fkeys menu, to send a signature block at the left margin:

Sincerely yours,

Your Name

1 Press **[Ctrl] [Shift] [F7]** to display *S F7* in the key definition field.

2 Enter three linefeed control codes (LF) and one carriage return control code (CR) by pressing

**[Ctrl] [J]** three times  
**[Ctrl] [M]**

3 Type

Sincerely yours,

4 Enter five LF control codes and one CR control code by pressing

**[Ctrl] [J]** five times  
**[Ctrl] [M]**

5 Type your name. Your entry now looks similar to the following:

␣␣␣␣␣␣ Sincerely yours,  
␣␣␣␣␣␣ Your Name

6 Exit setup mode. Now you can press **[Shift] [F7]** to end your letters with your signature block.

To select the Buffer setting and redefine a key,

1 Press **[F11]** to select the Fkeys menu in setup mode.

2 Look at the setting of the Buffer. It shows either *Temp* (the default temporary memory setting) or *NVR* (the battery-backed nonvolatile memory setting). When the setting is

*Temp* Your key definitions are lost when you turn off the power. One page of display memory is reassigned and reserved for function key definitions when you set the Buffer to *Temp*, save your changes, and exit setup mode.

*NVR* Your key definitions are automatically saved in memory when you turn off the power.

3 If you don't need to change the Buffer setting, go to the next step.

■ **Caution** If you do need to change the Buffer setting, press **[▶] ([→])** to select it. Then exit and reenter setup mode as follows:

a Press **[F12]** to exit the Fkeys menu.

b Select *Yes* for the Save? setting.

c Press **[F12]** to exit setup mode.

d Reenter setup mode and press **[F11]** to select the Fkeys menu.

4 Select the key to be redefined by pressing that key together with **[Ctrl]**. This enters the unshifted key name into the key definition field. (For a shifted key, press the key together with **[Ctrl]** and **[Shift]**.)

5 Enter the key definition (up to 64 characters) at the cursor position. Correct errors by pressing **[◀] ([←])** to delete characters or **[Home] ([F14])** to clear the definition.

□ **Note** All methods of entering characters from your keyboard in normal operating mode are available in setup mode.

6 To change the key's direction, press **[Enter] kpd** until your choice appears. When the setting is

*Remote* Key definitions are sent to the computer only, regardless of the terminal's communication mode. This is the default direction of all the keys.

*Local* Key definitions are sent to the terminal only, regardless of the terminal's communication mode.

*Normal* Key definitions are sent to the computer and/or the terminal, depending on the terminal's communication mode (i.e., the setting of the Comm setup parameter).

- Two-key sequences are supported in all keyboard languages that contain the specific nonspacing diacritical mark that introduces the sequence (see Tables B-1, B-2, and B-3).
- Three-key sequences are supported in all keyboard languages when the Corner Key setup parameter (Keyboard menu) is set to *compose*.

The characters you can compose depend on the setting of the Codepg setup parameter (Keyboard menu). Table B-5 lists all the composable characters and identifies which PC character set(s) support each character. Following is a list of all possible Codepg settings and the corresponding column headings in Table B-5:

Codepg Setting	Column Heading in Table B-5
PC Wyse ASCII	<i>PC Multinat.</i>
PC Multinat'l	<i>PC Multinat.</i>
PC Multilingual	<i>PC Multiling.</i>
PC Fr Canadian	<i>PC Fr. Can.</i>
PC Norwegian	<i>PC Norw.</i>
PC Spanish	<i>PC Span.</i>
PC Portuguese	<i>PC Port.</i>
PC Slavic	<i>PC Slav.</i>
PC Cyrillic	<i>PC Cyril.</i>
PC Turkish	<i>PC Turk.</i>
PC Polish	<i>PC Pol.</i>

To compose a character,

- 1 Find the character you want to compose in the first column of the table.
- 2 Make sure it is available for your current Codepg setting.
- 3 Refer to the third column for the two-key or three-key sequence that composes the character.

To compose the character with a two-key sequence, enter the two characters shown under "2-Key" in the order shown.

For example, to compose *à* when Codepg is set to *PC Multinat'l*, press **[◡]** first and then **[a]**.

To compose the character with a three-key sequence, first press and release **[Funct] ([Compose Character], [Alt] left)**, then enter the two characters shown under "3-Key" in any order.

For example, to compose *à* with a three-key sequence when Codepg is set to *PC Multinat'l*, press and release **[Funct] ([Compose Character], [Alt] left)**, then press **[◡]** and **[a]** in any order.

*For three-key sequences, the Corner Key setup parameter must be set to compose.*

**Table B-4 Compose Character Sequences: National Mode (ASCII Personalities), Continued**

Composed Character	Description	3-Key Sequence <sup>1</sup>	Composed Character	Description	3-Key Sequence <sup>1</sup>
<b>French Canadian Keyboard</b>					
à	a grave	` a	î	i circumflex	^ i
â	a circumflex	^ a	ô	o circumflex	^ o
è	e grave	` e	û	u grave	` u
é	e acute	' e	û	u circumflex	^ u
ê	e circumflex	^ e	ç	c cedilla	, c
<b>Latin American Keyboard</b>					
á	a acute	' a	ñ	n tilde	~ n
é	e acute	' e	ú	u acute	' u
í	i acute	' i	ü	u umlaut	" u
<b>Portuguese Keyboard</b>					
Ã	A tilde	A ~	ã	a tilde	a ~
Õ	O tilde	O ~	õ	o tilde	o ~
<b>Spanish Keyboard</b>					
£	Pound <sup>2</sup>	L -	§	Section	O S
		L =			! S
º	Masculine ordinal <sup>2</sup>	O _			
<b>Swedish Keyboard</b>					
Û	U umlaut	" U	É	E acute	' E
ü	u umlaut	" u	é	e acute	' e

1. First press the corner key. The other two keys can be pressed in any order.

2. Alphabetic keys can be entered in uppercase or lowercase.

### Composing Characters in Multinational Mode (ASCII Personalities)

In multinational mode, two-key and three-key sequences are supported in all ASCII personalities that support both 7- and 8-bit characters (Wyse 60, Wyse 120, Wyse 120+, Wyse 150, Wyse 150+, and PC Term).

You can compose characters with a two-key or three-key sequence in any keyboard language:

7 Press **[F12]** to exit the Fkeys menu.

8 Select *All* to save the key definition, and exit setup mode.

*Step 8 is not necessary when Buffer is set to NVR because key definitions are automatically saved.*

Key definitions share approximately 500 bytes of memory space with the answerback message. If you enter more than 64 characters for any one key, or reach the 500-byte overall limit, you'll hear the warning bell and won't be able to enter additional characters.

To send or display the key definition when the terminal is in scan code mode (Keycode parameter set to *scan*), press **[Setup]** (**[Select]**) together with the redefined key.

### SCHEDULING A REST

On the Miscellaneous setup menu, you can set the terminal to remind you to take a rest after a specified period of uninterrupted keyboard activity. After the period specified for keyboard activity has elapsed, a bell sounds and the message *REST* appears on the status line for the duration of the scheduled rest time. For example, the *5/30* setting schedules a 5-minute rest for every 30 minutes of uninterrupted keyboard activity.

Continuing this example, if you interrupt keyboard activity before 30 minutes have elapsed, the terminal tracks the time-out as follows:

- If the time-out is less than five minutes, the upcoming rest time is shortened by the number of minutes of inactivity. For example, if your time-out was two minutes long, the upcoming rest time is shortened to three minutes instead of five.
- If the time-out is more than five minutes, the terminal resets the activity period for another 30 minutes of uninterrupted keyboard activity. For example, if you interrupt keyboard activity after 15 of the 30 minutes have elapsed, and you don't return to the keyboard until 10 minutes later, the terminal resets the activity period to a full 30 minutes from the time you return to the keyboard.

**Note** If you start typing four minutes into a 5-minute scheduled rest time, the *REST* message remains on the status line until future time-outs use up the remaining one minute.

### KEY FUNCTIONS

When the terminal is communicating with the host in full- or half-duplex mode, most keys perform *remote* functions. That is, they send codes that are interpreted and acted upon by the host operating system and your application programs.

Certain keys and key combinations perform *local* functions that initiate actions by the terminal. Table 9 lists the local keyboard commands.

**Table 9 Local Keyboard Commands by Keyboard Style**

Command	ASCII	105-Key ANSI	Enhanced PC-Style
Turn CAPS LOCK on/off <sup>1</sup>	<b>Caps Lock</b>	<b>Lock</b>	<b>Caps Lock</b>
Turn NUM LOCK on/off <sup>1</sup>	<b>F15</b>	<b>PF1</b>	<b>Num Lock</b>
Put terminal in setup mode	<b>Shift Setup</b> OR <b>Ctrl Setup</b> <sup>2</sup>	<b>F3</b> OR <b>Ctrl Select</b> <sup>2</sup>	<b>Shift Select</b> OR <b>Ctrl Select</b> <sup>2</sup>
Perform soft (partial) reset <sup>3</sup>	<b>Setup</b>	<b>Shift F3</b>	<b>Select</b>
Perform hard (power-on) reset	<b>Ctrl Shift Setup</b>	<b>Ctrl Shift F3</b>	<b>Ctrl left Shift left Select</b>
Send break	<b>Break</b>	<b>F5</b>	<b>Ctrl Break</b>
Turn block mode on/off	<b>Shift Break</b>	<b>F4</b>	<b>Ctrl Shift Break</b>
Print formatted screen	<b>Ctrl Shift . kpd</b>	<b>Ctrl Shift . kpd</b>	<b>Ctrl Shift . kpd</b>
Turn auxiliary print mode on/off	<b>Ctrl Print</b>	<b>Ctrl F2</b>	<b>Ctrl Shift Print Screen</b>
Turn monitor mode on/off	<b>Ctrl Shift 1 kpd</b>	<b>Ctrl Shift 1 kpd</b>	<b>Ctrl Shift 1 kpd</b>
Turn keyclick on/off	<b>Shift Enter kpd</b>	<b>Shift Enter kpd</b>	<b>Shift Enter kpd</b>
Select <i>alt legend</i> as Corner Key setup parameter setting		<b>Ctrl Shift</b> <b>Compose Character</b>	<b>Ctrl Shift Alt left</b>
Select <i>compose</i> as Corner Key setup parameter setting	<b>Ctrl Funct</b>	<b>Ctrl Compose Character</b>	<b>Ctrl Alt left</b>
Toggle between standard and alternate keyboard layouts <sup>4</sup>		<b>Ctrl Shift</b> <b>←</b>	<b>Ctrl Shift</b> <b>←</b>
In Polish keyboard language, toggle between standard Polish-1 and Polish-2 keyboard layouts			<b>Shift left Shift right</b>
Change status line display (standard, off, editing)	<b>Ctrl</b> <b>▶</b>	<b>Ctrl</b> <b>▶</b>	<b>Ctrl</b> <b>→</b>
Turn on instant screen saver <sup>5</sup>	<b>Ctrl Shift Clr Scrn</b>	<b>Ctrl Shift PF3</b>	

### Composing Characters in National Mode (ASCII Personalities)

In national mode, only three-key sequences are supported in ASCII personalities. Two-key sequences are not supported. The characters you can compose depend on your keyboard language.

Table B-4 lists the characters you can compose in each keyboard language. The table lists only the characters that you might want to compose—that is, characters that don't already appear on your keyboard.

To compose a character,

- 1 Set the Corner Key setup parameter to *compose*.
- 2 Find your keyboard language in Table B-4.
- 3 Find the character you want to compose in the “Composed Character” column of the table.
- 4 Press and release **Funct** (**Compose Character**), **Alt left**.
- 5 Enter the two characters from the column that lists the compose sequence. The two characters can be entered in any order.

For example, to compose *à* on the French Canadian keyboard, press and release **Funct** (**Compose Character**), **Alt left**, then press **^** and **a** in any order.

**Table B-4 Compose Character Sequences: National Mode (ASCII Personalities)**

Composed Character	Description	3-Key Sequence <sup>1</sup>	Composed Character	Description	3-Key Sequence <sup>1</sup>
<b>Dutch Keyboard</b>					
¼	One-fourth <sup>2</sup>	1 4	f	Florin <sup>2</sup>	f -
½	One-half <sup>2</sup>	1 2		Vertical line	/ ^
¾	Three-fourths <sup>2</sup>	3 4	"	Diacresis (umlaut)	" ^
ij	ij sign <sup>2</sup>	i j			
<b>Finnish Keyboard</b>					
é	e acute	/ e			
<b>French/Belgian Keyboard</b>					
£	Pound <sup>3</sup>	L -			
		L =			

**Table B-3 Nonspacing Diacritical Marks (International Enhanced PC-Style Keyboard), Continued**

Keyboard Language	Grave Accent	Acute Accent	Circumflex	Tilde	Umlaut	Hacek	Ring	Ogonek	Double Acute	Dot Above	Breve	Cedilla
Hungarian	`	´	ˆ	˜	¨	ˇ	◊	◌	˝	˙	˘	¸
Italian			ˆ									
L.A. Spanish	`	´	ˆ	˜	¨							
Polish		´										
Portuguese	`	´	ˆ	˜	¨							
Romanian	`	´	ˆ	˜	¨	ˇ	◊	◌	˝	˙	˘	¸
Slovak		´	ˆ		¨	ˇ	◊					
Spanish	`	´	ˆ		¨							
Swedish	`		ˆ	˜								
Swiss (Fr/Ger)	`		ˆ	˜								
Turkish	`											

**COMPOSING CHARACTERS IN ASCII PERSONALITIES**

In any ASCII personality that supports both 7- and 8-bit characters (Wyse 60, Wyse 120, Wyse 120+, Wyse 150, Wyse 150+, PC Term), you can compose characters in both national and multinational modes.

In all other ASCII personalities, you can compose characters in national mode only.

- Note** To compose characters, the Keycode setup parameter must be set to *ASCII*. You cannot compose characters when the terminal is in PC scan code mode except when the terminal is in block, half-duplex block, or local communication mode.

**Table 9 Local Keyboard Commands by Keyboard Style, Continued**

Command	ASCII	105-Key ANSI	Enhanced PC-Style
Increase scrolling rate	Ctrl Shift ▲	Ctrl Shift ▲	Ctrl Shift ↑
Decrease scrolling rate	Ctrl Shift ▼	Ctrl Shift ▼	Ctrl Shift ↓
Home cursor and clear page	Ctrl Shift Home	Ctrl Shift Prev Scrn	Ctrl Shift Home
Display page of memory <sup>6,7</sup>	Ctrl <i>n</i> kpd	Ctrl <i>n</i> kpd	Ctrl <i>n</i> kpd
Display next page (or activate other window <sup>8</sup> )	Ctrl Next Page	Ctrl Next Scrn	Ctrl Page Down
Display previous page (or activate other window <sup>8</sup> )	Ctrl Prev Page	Ctrl Prev Scrn	Ctrl Page Up
Send answerback message <sup>7,9</sup>	Ctrl Break	Ctrl F5	Shift Pause
Roll active window up in page <sup>7</sup>	Ctrl ▲	Ctrl ▲	Ctrl ↑
Roll active window down in page <sup>7</sup>	Ctrl ▼	Ctrl ▼	Ctrl ↓
Raise horizontal split <sup>7</sup>	Ctrl -] kpd	Ctrl -] kpd	Ctrl -] kpd
Lower horizontal split <sup>7</sup>	Ctrl [.] kpd	Ctrl [.] kpd	Ctrl [.] kpd
Toggle between split screen and full screen format <sup>10</sup>	Ctrl Shift -] kpd	Ctrl Shift [.] kpd	Ctrl Shift -] kpd
Toggle between insert and replace modes	Ctrl Ins	Ctrl PF4	

1. You can save the *on* or *off* setting by entering setup mode, selecting *Yes* or *All* for the Save? setting, and exiting setup mode.
2. In PC Term personality or if Keycode setup parameter is set to *scan*.
3. Unlock keyboard, turn off print modes if active, turn display on if off, turn cursor on if off, reset received XOFF state, reinitialize UART.
4. On international keyboards that have alternate characters on the right side or front face of the keycaps.
5. Scrn Saver parameter must be *on*.
6. *n* equals the page number.
7. Not supported in the default Wyse 50 personality.
8. If screen is split.
9. In ASCII personalities only, Answerback Mode setup parameter must be *on*.
10. Splits screen at line 12.





The compose sequence introducer for a two-key sequence is a *nonspacing diacritical mark*.

Unlike typical keys on your keyboard, a nonspacing diacritical mark key (such as the acute accent) does not display or send the diacritical mark when pressed. Instead, the diacritical mark is added to the next alphabetical key pressed. For example, pressing [´] and then [e] composes [é].

- **Note** Two-key sequences are not available in the U.S. keyboard language on any keyboard.

The compose sequence introducer for a three-key sequence is the corner key (when the Corner Key setup parameter [Keyboard menu] is set to *compose*). The corner key is [Funct] on the ASCII keyboard, [Compose Character] on the 105-Key ANSI keyboard, and [Alt] left on the Enhanced PC-style keyboard.

**Cancelling Compose Sequences**

When you begin a compose character sequence, *Comp* appears on the status line. The *Comp* message disappears when you complete the sequence. If you enter an invalid character during the sequence, the warning bell sounds and the sequence is canceled.

You can cancel a compose character sequence at any time by pressing [Back Space] ([X], [← Back Space]).

**Nonspacing Diacritical Marks**

Tables B-1, B-2, and B-3 list the keyboard languages that support nonspacing diacritical marks in each keyboard style. Not all nonspacing diacritical marks can be used in compose sequences in national mode. Refer to the national mode tables for ASCII and ANSI personalities (Tables B-4 and B-6).

**Table B-1 Nonspacing Diacritical Marks (ASCII Keyboard)**

Keyboard Language	Grave Accent	Acute Accent	Circumflex	Umlaut
French/Belgian	`	´	ˆ	¨
German	`	´	ˆ	
Spanish	`	´	ˆ	
Swiss (Fr/Ger)	`		ˆ	¨

**Table 10 Terminal Status Messages, Continued**

Message	Meaning
BLK	The terminal is in block mode.
HBLK	The terminal is in half-duplex block mode.
<FDX <HDX <BLK <HBLK	The terminal is sending data to the computer while in the indicated communication mode.
HLD	Data is being held on the screen (processing is suspended).
REST	It is time to take a scheduled rest.
>AUX	The terminal is in auxiliary print or transparent print mode.
<AUX	The terminal is in auxiliary receive mode.
=AUX	The terminal is in auxiliary receive mode and auxiliary print mode (bidirectional).
PBSY	The printer is busy <sup>2</sup> (not ready to receive data) or no printer is connected.
lll-ccc	The cursor is on line <i>lll</i> , column <i>ccc</i> .
PROT <sup>3</sup>	Protect mode is on.
WPRT <sup>3</sup>	Write-protect mode is on (displayed only when protect mode is also on).
INS <sup>3</sup>	Insert mode is on.
L1...L4	Simulated keyboard LED (L1, L2, L3, L4) is on (ANSI personalities only).

1. International Enhanced PC-style keyboard only.
2. You can abort a print command by pressing [Setup] ([Shift] [F3], [Select]) to partially reset the terminal.
3. Displayed only when an editing status line has been turned on by your application or by a local key command (see Table 9).

**Screen Saver**

The terminal's screen saver feature prolongs the life of the screen's phosphor by turning off the screen display after the terminal has received no data for approximately 15 minutes. The display reappears when you press any key. You can turn off the screen saver feature in setup mode (Display menu).

As long as the screen saver feature is on, you can obtain instant privacy by turning off the screen display at any time: Press **Ctrl** **Shift** **Cir Scrn** (**Ctrl** **Shift** **PF3** on the 105-Key ANSI keyboard; not available on the Enhanced PC-style keyboard). To turn the display on again, press any key.

**PRINTING**

If you have connected a printer to the terminal, you can print data from the computer or from the screen (the terminal's display memory).

To print data from the computer,

- 1 Connect the printer to the port selected in the Host Port and Printer Attached setup parameters (see Table 5).
- 2 Enable receive handshaking on the host port (Rc Hsk parameter set for the type of handshaking supported by your computer).
- 3 Press **Ctrl** **Print** (**Ctrl** **F2**), **Ctrl** **Shift** **Print Screen** ) to turn on auxiliary print mode.
- 4 Press the keys again to turn off the print mode.

- Note** You can abort a print command at any time by pressing **Setup** (**Shift** **F3**, **Select**) to partially reset the terminal.

To print a page of data from display memory (local print),

- 1 Press **Shift** **Break** (**F4**, **Ctrl** **Shift** **Break**) to put the terminal in block mode.
- 2 Press **Ctrl** **Shift** **.kpd**.

- Note** Because data is sent from the top of the page through the cursor position, the cursor must be at the bottom of the page if the entire page is to print.

- 3 When you are finished printing, press **Shift** **Break** (**F4**, **Ctrl** **Shift** **Break**) again to turn off block mode.

- Caution** Avoid entering data during print operations. Keyboard data sent to the computer that is echoed by the computer can become mixed with data going to the printer port.

# B Composing Characters

**INTRODUCING COMPOSE SEQUENCES**

You can enter two-key or three-key compose sequences to display characters that are contained in the terminal's character sets but are not represented as standard keys on your keyboard.

The characters you can compose depend on

- Whether the terminal is in *national* or *multinational* mode. (The mode is selected in ASCII personalities by setting the ASCII setup parameter [Keyboard menu] and in ANSI personalities by setting the Char Mode setup parameter [ANSI 1 menu]).
  - In national mode you can compose only the 7-bit characters contained in your selected character set.
  - In multinational mode you can compose both the 7- and 8-bit characters contained in your selected character set.
- The currently selected character set. (Character sets are selected in ASCII personalities by setting the Codepg setup parameter [Keyboard menu] and in ANSI personalities by setting the Char Set setup parameter [ANSI 1 menu]).
- The terminal's current personality.
  - If the terminal is in a personality that supports only 7-bit characters (Wyse 50, Wyse 50+, ADDS A2, HZ 1500, TVI 910+, TVI 925, TVI 905, VT52, VT100), you can compose characters only in national mode.
  - If the terminal is in a personality that supports both 7- and 8-bit characters (Wyse 60, Wyse 120, Wyse 120+, Wyse 150, Wyse 150+, PC Term, VT220), you can compose characters in both national and multinational modes.

*Exceptions for UNIX Console personality: National mode is not supported. In multinational mode, select your character set by setting the Codepg parameter. See Table B-5 for the characters in your selected character set that you can compose.*

**Entering Compose Sequences**

You enter compose sequences by pressing a *compose sequence introducer* and either one additional key (two-key sequence) or two additional keys (three-key sequence).

# A Connector Pin Assignments

Figures A-1 and A-2 show the connector pin assignments for the Modem and Aux ports.

**Figure A-1 MODEM Port Connector Pin Assignments (RS-232C)<sup>1</sup>**

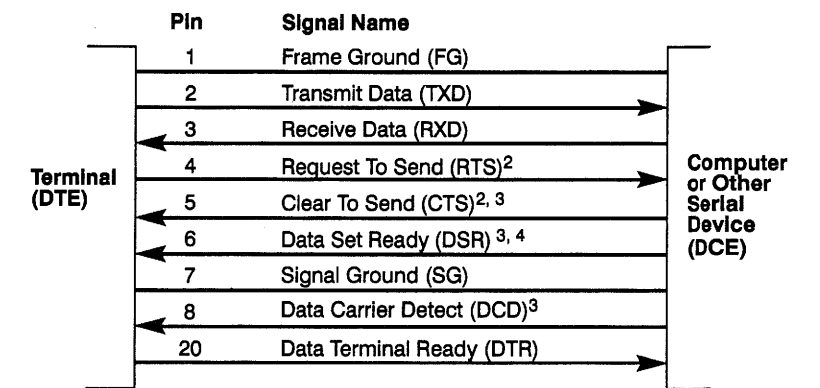
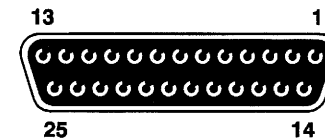

1. For most terminal-to-host connections, only pins 1, 2, 3, and 7 need to be connected if XON/XOFF handshaking is used. Pin 20 must also be connected if DTR hardware handshaking is selected.
2. Pins 4 and 5 should be connected if half-duplex or half-duplex block communication mode is used.
3. Modem protocol when the port is configured as the host port—connect these pins only if you are using a modem that requires modem control signals. If pin 5 is low, the terminal won't transmit any data. If pin 8 is low, the terminal won't receive any data.
4. Used for hardware handshaking signals when the port is configured as a printer port. (The terminal also recognizes XON/XOFF software handshaking from the printer.) For most terminal-to-printer connections, only pins 1, 2, 3, 6, and 7 need to be connected.

**Figure A-2 AUX Port Connector Pin Assignments (RS-232C)<sup>1</sup>**

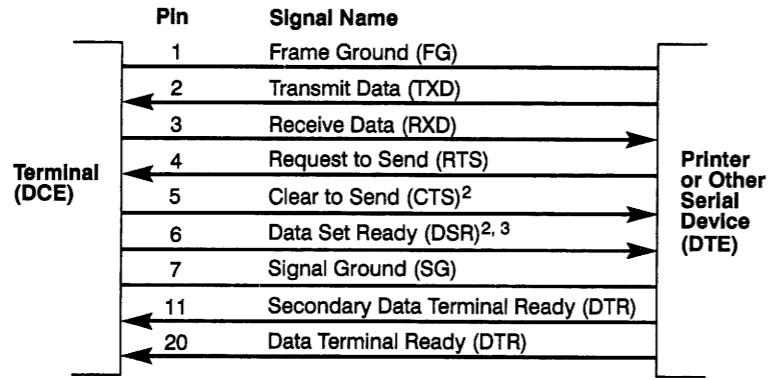
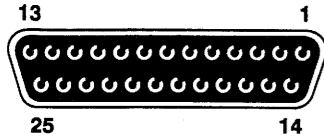

1. For most terminal-to-printer connections, only pins 1, 2, 3, and 7 need to be connected if XON/XOFF handshaking is used. Pin 11 or pin 20 must also be connected if DTR hardware handshaking is selected.
2. Modem protocol when the port is configured as the host port—connect these pins only if you are using a modem that requires modem control signals. If pin 4 is low, the terminal won't transmit any data.
3. Used for hardware handshaking signals when the port is configured as a host port. (The terminal also recognizes XON/XOFF software handshaking from the printer.) For most terminal-to-host connections, only pins 1, 2, 3, 6, and 7 need to be connected.

**Figure A-3 Parallel Port Connector Pin Assignments (ES Models Only)<sup>1</sup>**

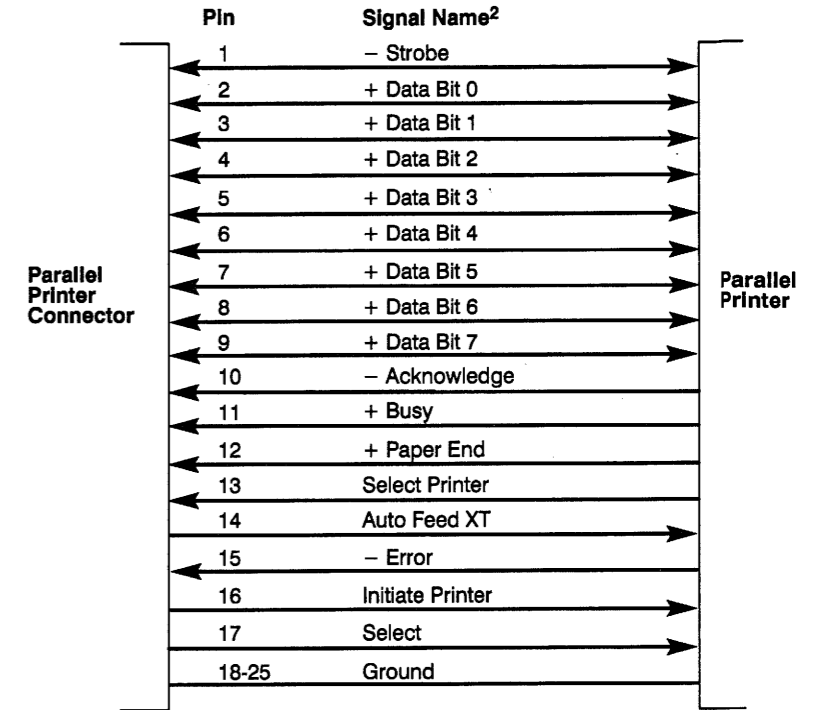
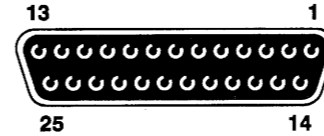

1. All inputs are real-time (nonlatched) signals.
2. All signals are standard TTL levels.