

TEAC FD-235HS-1100
MICRO FLOPPY DISK DRIVE
HARDWARE SPECIFICATION

REV.A

TABLE OF CONTENTS

Title	Page
1. GENERAL	4
2. BASIC SPECIFICATIONS	5
3. SYSTEM CONFIGURATION	6
3.1 System Configuration	6
3.2 Connection to the Host System	7
4. DISK	8
5. PHYSICAL SPECIFICATIONS	8
5.1 Physical Specifications	8
5.2 Frame Grounding	10
5.3 Nameplate	10
6. FUNCTIONAL SPECIFICATIONS	11
6.1 2MB Mode Data Capacity	11
6.2 1MB Mode Data Capacity	11
6.3 Disk Rotation Mechanism	12
6.4 Index Detection	12
6.5 Track Construction	12
6.6 Magnetic Head	12
6.7 Track Seek Mechanism	13
6.8 Others	13
7. ENVIRONMENTAL CONDITIONS	14
8. RELIABILITY	15
9. POWER INTERFACE	16
9.1 Required Power	16
9.2 Power Interface Connector and Cable	16
10. SIGNAL INTERFACE	18
10.1 Electrical Characteristics	18
10.2 Signal Interface Connector and Cable	20
10.3 Input and Output Signals	23
10.4 Phase Sequence	24
10.5 Interface Timing	25
10.6 Control Sequence	37
10.6.1 Initialized state when the power is switched on or reset	37
10.6.2 Disk Installation	38
10.6.3 Current consumption profile	39
10.7 Setting the Mode for the SFD	40
10.7.1 Method A	40
10.7.2 Method B	41

10.8 Customer Selectable Straps	42
10.8.1 Straps setting on the FC-1 board	42
10.8.2 Strap setting on the FDD main board	44

1. GENERAL

This is the hardware specification of the TEAC FD-235HS, 3.5" double-sided 5.3 track/mm [135tpi] micro floppy disk drive (hereinafter referred to as SFD) with a data capacity of 2MB/1MB (2 modes) and a SCSI interface board (hereinafter referred to as FC-1).

For the specification of the software, refer to "FC-1-10 Software Specification".

The outline of this SFD is shown in Table 1.

(Table 1) Specification outline

Model name	FD-235HS-1100	
TEAC P/N	19308111-00	
ROM P/N	S002617-10	
Safety standard	UL, CSA & TÜV	
Operation modes	1MB mode, write/read	2MB mode, write/read
Disk used	Normal density (DD)	High density (HD)
Data transfer rate	250k bits/s	500k bits/s
Disk speed	300rpm	
Track density	5.3 track/mm [135tpi]	
Required power	+5V single (4.75~5.25V)	
Front bezel & flap	Black	
Eject button	Black	
LED indicator color	Amber	
Signal interface	SCSI (Small Computer System Interface: ANSI standard X3.131-1986)	
Terminator	Provided (at factory), 220/330Ω ±5%, detachable	
Specification of parity	ON (at factory), ON/OFF switchable	
Specification of SCSI	ID=0 (at factory), SCSI ID 0 to 7 switchable	
Logical Unit Number	LUN=0 (at factory)	
Internal data buffer capacity	31K bytes	

Using two types of disk, this SFD permits two write/read modes with unformatted data capacities of 2M/1M bytes. The interface with the host system is SCSI. The SFD has a switch for the detection of the high density identification hole (HD hole) in the disk and straps for selecting the density mode system (refer to 10.8).

2. BASIC SPECIFICATIONS

- (1) Signal interface : Pursuant to the ANSI standard X3.131-1986
- (2) System configuration : Multiple initiators connectable
- (3) Reselection : Available (LEVEL 2 compatible)
- (4) Electrical characteristics : Single-end driver/receiver

(5) Effective commands

TEST UNIT READY	RESERVE UNIT
REZERO UNIT	RELEASE UNIT
REQUEST SENSE	MODE SENSE
FORMAT UNIT	START/STOP UNIT
FORMAT TRACK	SEND DIAGNOSTIC
READ	READ CAPACITY
WRITE	READ EXTEND
SEEK	WRITE EXTEND
INQUIRY	SEEK EXTEND
MODE SELECT	VERIFY
WRITE AND VERIFY	

(6) Terminator power

Provided with TERMPWR terminal to supply the interface with TERMPWR.

(7) SCSI ID ADDRESS

Setting 0 through 7 possible with the straps on the board. This is set to 0 at factory.

(8) Parity check

While parity check is always performed on output data from SFD, whether the check to be done or not on input data can be selected with a strap on the board.

(9) Data transfer capacity

: 556k bytes/s (Asynchronous transfer)

However, this value is the average transfer speed in the case the host system responds in the shortest time.

3. SYSTEM CONFIGURATION

3.1 System Configuration

The following system configurations are available with the SCSI interface unit. When more than one target is connected, it is necessary to remove termination resistors except for that at the terminating target.

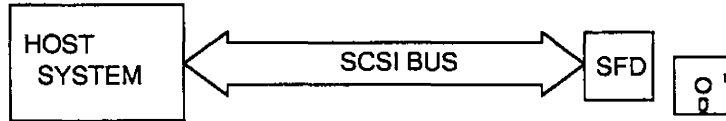

SINGLE INITIATOR, SINGLE TARGET

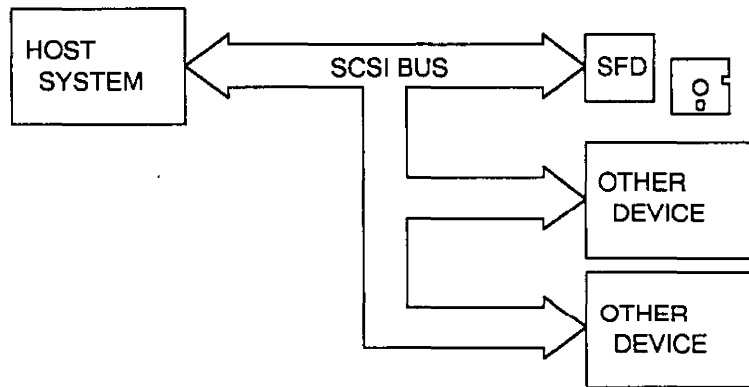

SINGLE INITIATOR, MULTI TARGET

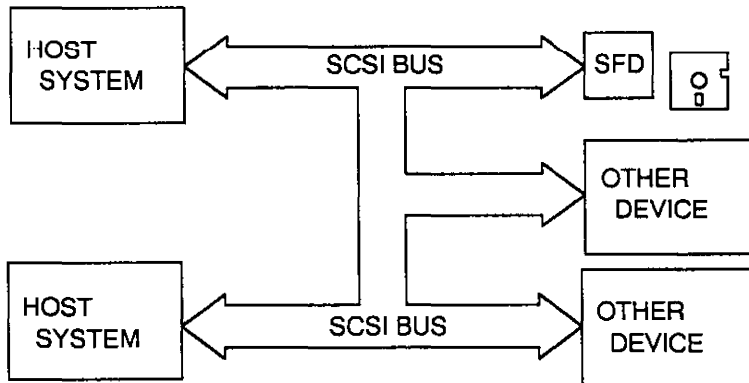

MULTI INITIATOR, MULTI TARGET

(Fig.1) System configuration

3.2 Connection to the Host System

The SFD is either incorporated into the host system of the IBM-PC, IBM-PS/2, etc. and connected to an independent SCSI device or used as part of a subsystem as shown below.

- (1) When incorporating the SFD into the host system using daisy chain connection, it is necessary to use the interface cable, the middle part of which is connected to the interface connector. (Refer to Fig.2)

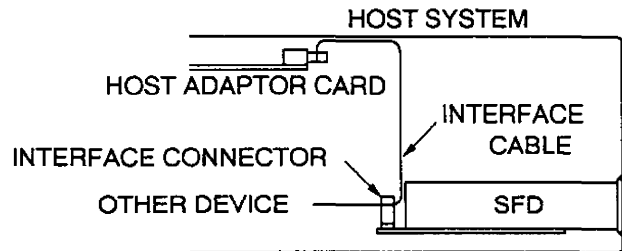

(Fig.2) Daisy chain connection within the host system

- (2) When constructing a subsystem, run the cable from the drive connector as shown in Fig.3, then install two sets of connectors onto the back panel of the subsystem. It is desirable that both of the two connectors are connected.

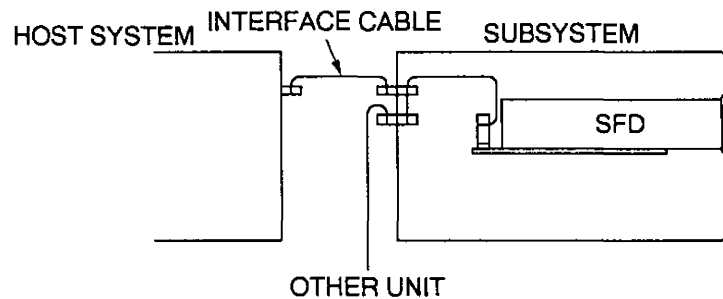

(Fig.3) Daisy chain connection when incorporated into subsystem

* IBM-PC and IBM-PS/2 are trademarks of International Business Machines Corporation.

In each case, the total length of the interface cable(s) used shall not exceed 6m.

When the interface cable extends out of the system, use shielded cables and connectors which shall protect the signals from radiation noise.

4. DISK

(1) Work disk

3.5" micro floppy disks on Table 2 which are mutually agreed between the customer and TEAC.

(Table 2) Disk used

Operation mode	Disk type	Magnetic powder	Magnetizing method
1MB	Normal density (DD)	Co- γ -Fe ₂ O ₃	Surface recording
2MB	High density (HD)	Co- γ -Fe ₂ O ₃	Surface recording

(2) Cleaning disk

The SFD does not require any cleaning disk. However, the dry type disk which is mutually agreed between the customer and TEAC is used when requiring a cleaning disk.

5. PHYSICAL SPECIFICATIONS

5.1 Physical Specifications

(Table 3) Physical specification

Width	101.6mm [4.00 in], Nom.
Height	33.3mm [1.31 in], Nom.
Depth	162mm [6.38 in], Nom.
Weight	480g [1.06lbs], Nom., 500g [1.10 lbs], Max.
External view	See fig.4.
Cooling	Natural air cooling
Mounting	Mounting for the following directions are acceptable. (a) Front loading, mounted vertically. (b) Front loading, mounted horizontally with spindle motor down. (c) Mounting angle in items (a) and (b) should be less than 25° with front bezel up or down. Note: As to the other mounting directions than the above will be considered separately.
Installation	With installation holes on the frame of the SFD. Refer to Fig.4.
Material of frame (Base)	Aluminium die-cast
Material of SCSI bracket	A galvanized sheet iron
Material of front bezel	PPHOX

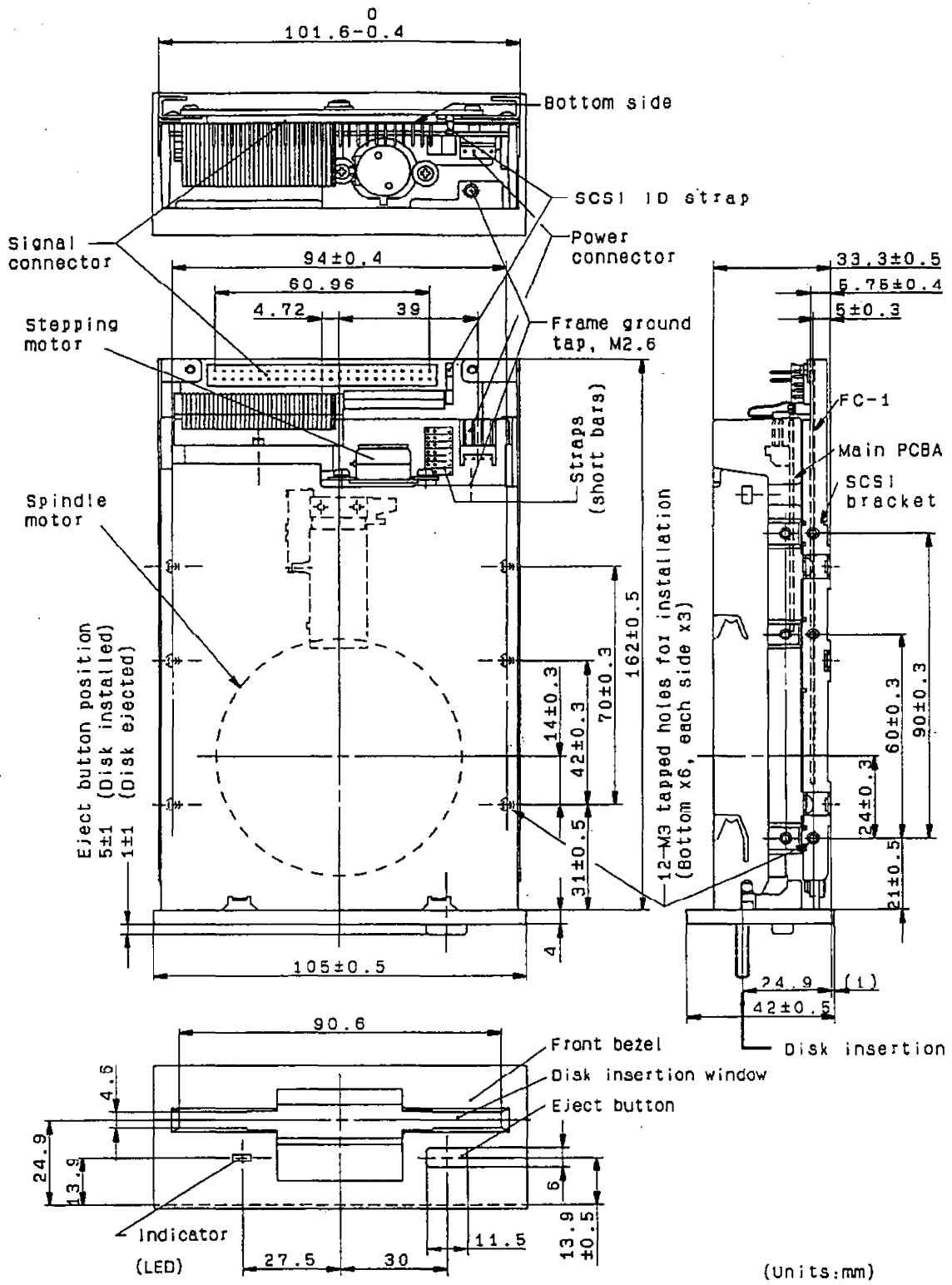

(Units:mm)

(Fig.4) External view

5.2 Frame Grounding

- (1) The SFD frame is electrically connected to DC 0V by FG strap on the main PCBA. (See Fig.5)
- (2) If it is required to separate the frame from DC 0V, set the FG strap to off-state.
- (3) If it is required to ground by other cabling method, use M2.6 tapped hole at the rear side of the SFD. (See Fig.4)

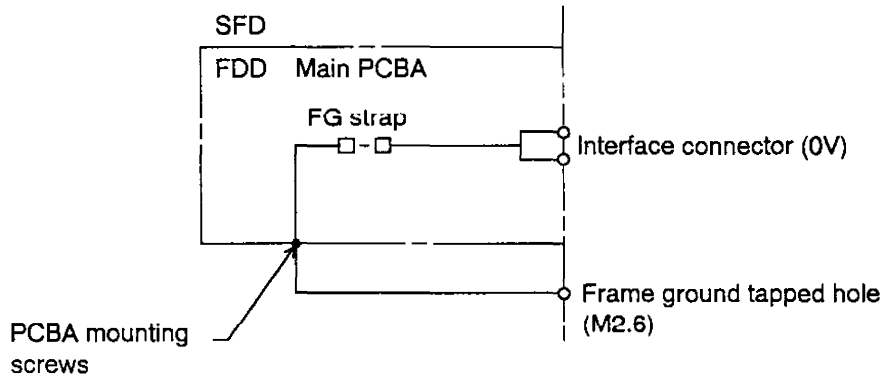

(Fig.5) Frame ground internal connection

5.3 Nameplate

The location where the nameplate is attached onto the SFD is shown in Fig. 6.

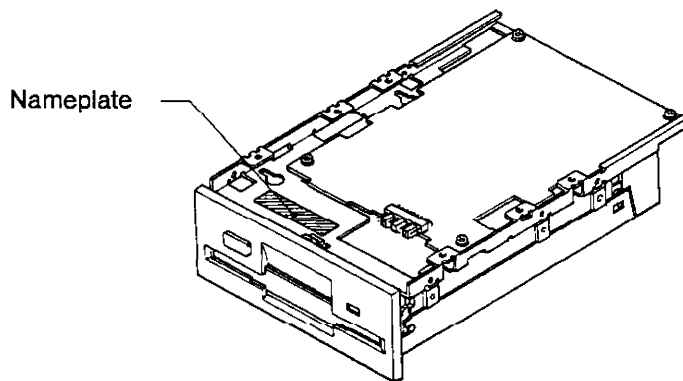

(Fig.6) Location where the nameplate is attached

Note: Although the nameplate is attached on the rear (interface connector side) of the SFD, this nameplate is for the base FDD (the SFD minus the SCSI board, bracket, etc.) and does not indicate the model number, model name or serial number of the SFD.

6. FUNCTIONAL SPECIFICATIONS

6.1 2MB Mode Data Capacity

(Table 4) 2MB mode data capacity

Encoding method		FM	MFM		
Data transfer rate between FC-1 - FDD (k bits/s)		250	500		
Tracks/disk		160	160		
Innermost track bit density (bpi), Side 1		8,717	17,434		
Innermost track flux density (frpi), Side 1		17,434	17,434		
Data capacity	Unformatted	k bytes/track	6.25	12.50	
		k bytes/disk	1,000	2,000	
	Formatted	32 sectors /track	k bytes/sector	0.128	0.256
			k bytes/track	4.096	8.192
			k bytes/disk	655.36	1,310.72
	Formatted	18 sectors /track	k bytes/sector	0.256	0.512
			k bytes/track	4.608	9.216
			k bytes/disk	737.28	1,474.56
	Formatted	10 sectors /track	k bytes/sector	0.512	1.024
			k bytes/track		10.24
			k bytes/disk	819.20	1,638.40

6.2 1MB Mode Data Capacity

(Table 5) 1MB mode data capacity

Encoding method		FM	MFM		
Data transfer rate between FC-1 - FDD (k bits/s)		125	250		
Tracks/disk		160	160		
Innermost track bit density (bpi), Side 1		4,359	8,717		
Innermost track flux density (frpi), Side 1		8,717	8,717		
Data capacity	Unformatted	k bytes/track	3.125	6.250	
		k bytes/disk	500	1,000	
	Formatted	16 sectors /track	k bytes/sector	0.128	0.256
			k bytes/track	2.048	4.096
			k bytes/disk	327.68	655.36
	Formatted	9 sectors /track	k bytes/sector	0.256	0.512
			k bytes/track	2.304	4.608
			k bytes/disk	368.64	737.28
	Formatted	5 sectors /track	k bytes/sector	0.512	1.024
			k bytes/track	2.560	5.120
			k bytes/disk	409.60	819.20

6.3 Disk Rotation Mechanism

(Table 6) Disk Rotation Mechanism

Spindle motor	DC brushless motor
Spindle speed	300rpm
Motor servo method	Frequency servo by ceramic oscillator
Motor/spindle connection	Motor shaft direct
Disk speed	The same as the spindle speed.
Long term speed variation (LSV)	± 1.5% or less
Instantaneous speed variation (ISV)	± 2% or less
Start time	480ms or less
Average latency	100ms

6.4 Index Detection

(Table 7) Index Detection

Number of index	1 per disk revolution
Detection method	Rotor detection of spindle motor by Hall element or FG output.
Detection cycle	200ms ± 1.5%
Index burst detection timing error (with specified test disk)	± 400 μs or less

6.5 Track Construction

(Table 8) Track Construction

Track density	5.3 track/mm [135tpi] (track pitch 187.5 μm)
Number of cylinders	80 cylinders
Number of tracks	160 tracks/disk
Outermost track radius(track 00)	Side 0 39.500mm [1.5551 in]
	Side 1 38.000mm [1.4961 in]
Innermost track radius(track 79)	Side 0 24.6875mm [0.9719 in]
	Side 1 23.1875mm [0.9129 in]
Positioning accuracy	± 15 μm or less, with specified test disk (Track 40, 23 ± 2°C, 45~55%RH, horizontal)

6.6 Magnetic Head

(Table 9) Magnetic Head

Magnetic head	Read/write head with erase gap, 2 sets
Effective track width after trim erase	0.115 ± 0.008mm [0.0045 ± 0.0003 in]
Read/write gap azimuth error	0° ± 18', with specified test disk

6.7 Track Seek Mechanism

(Table 10) Track Seek Mechanism

Head position mechanism	Stepping motor and lead screw
Stepping motor	4-phase, 20 steps per revolution
Stepping motor drive	2 steps per track
Track 00 detection method	Photo-interrupter
Track to track time	3ms (excludes setting time)
Setting time	15ms or less (excludes track to time)
Average track seek time	94ms (includes setting time)

6.8 Others

(Table 11) Others

Recommendable write pre-compensation	
【2MB mode】	± 125ns
【1MB mode】	0~ ± 125ns
Head load mechanism	Not equipped (The FDD becomes head load condition whenever a disk is installed.)
File protect mechanism	Detection of write inhibit hole by switch
Disk detection mechanism	Detection of disk installation by switch
Disk inserting force	6.86N [700g] or less at the center of disk
Disk ejecting force	13.73N [1400g] or less
Acoustic noise at 50cm	50dBA or less at 3ms or 4ms seek operation
Disk type discriminating mechanism	Detection of HD hole by switch
Auto-recalibration	Automatic recalibration to track 00 is executed immediately after power-on.

7. ENVIRONMENTAL CONDITIONS

(Table 12) Environmental Condition

	Operating	Storage	Transportation
Ambient temperature	4-51.7°C [39-125°F]	- 22-60°C [- 8-140°F]	- 40-65°C [- 40-149°F]
Temperature gradient	20°C [68°F] or less per hour	30°C [86°F] or less per hour	30°C [86°F] or less per hour
Relative humidity	20-80% (no condensation) Max. wet bulb temperature shall be 29.4°C [85°F]	5-90% (no condensation) Max. wet bulb temperature shall be 40°C [104°F]	5-95% (no condensation) Max. wet bulb temperature shall be 45°C [113°F]
Vibration	14.7m/s ² [1.5G] or less (10-100Hz, 1 octave/m sweep rate)	/	19.6m/s ² [2G] or less (10-100Hz, 1/4 octave/m sweep rate)
	4.9m/s ² [0.5G] or less (100-200Hz, 1 octave/m sweep rate)		
	2.45m/s ² [0.25G] or less (200-600Hz, 1 octave/m sweep rate)		
Shock	Write & read: 49m/S ² [5G](11ms, 1/2 sine wave) or less	/	490m/S ² [50G] (11ms, 1/2 sine wave) or less
	Read only: 98m/S ² [10G](11ms, 1/2 sine wave) or less Soft errors are allowed if they are recoverable within 16 retries.		
Altitude	- 300m [- 980feet]- 5,000m [16,400feet]	/	12,000m [40,000 feet] or less
	Notes: The above requirements are applied for the FDD without shipping box. When a long period is required for transportation such as by ship, storage environmental conditions should be applied.		

8. RELIABILITY

(Table 13) Reliability

MTBF		30,000 power on hours or more (for typical operation duty)
MTTR		30 minutes or less
Design component life		5 years
Disk life		3×10^6 passes/track or more
Disk insertion		1.5×10^4 times or more
Seek operation		1×10^7 random seeks or more
Preventive maintenance		Not required (for typical operation duty)
Error rate	Soft error	1 or less per 10^9 bits read In the event of error, retry is performed up to 16 times automatically, including three recalibrations to track 00.
	Hard error	1 or less per 10^{12} bits read In the event of error, retry is performed up to 16 times automatically, including three recalibrations to track 00.
	Seek error	1 or less per 10^6 seeks In the event of error, retry is performed up to 16 times automatically, including three recalibrations to track 00.
Safety standard		Approved by UL, CSA and TÜV

9. POWER INTERFACE

9.1 Required Power

The following specifications are applied at interface connector of the SFD. Power is fed to the FC-1 via the signal interface cable (7, 9 and 11 pins) between FC-1 and FDD.

- (1) DC +12V: Not required
- (2) DC +5V
 - (a) Voltage tolerance: $\pm 5\%$ (4.75 ~ 5.25V)
 - (b) Allowable ripple voltage: 100mVp-p or less (including spike noise)
 - (c) Current and power consumption

(Table 14) Current and power consumption

Operating mode	Average current		Average power	
	Typ.	Max.	Typ.	Max.
Stand-by *1	85mA	105mA	0.43mW	0.55mW
Read operation *1	0.36A	0.46A	1.80W	2.42W
Write operation *1	0.36A	0.46A	1.80W	2.42W
Seek operation *1	0.54A	0.63A	2.70W	3.31W
Spindle motor start *1	0.70A	0.77A	3.50W	4.04W
Terminator Current *2	0.16A	0.30A	0.80W	1.58W

The current values of items marked *1 indicate those without the terminator.

The current values with the terminator will be those to which terminator current values marked *2 are added.

Notes:

1. Values of Typ. current and power are specified at 5.0V, while the values of Max. are at 5.25V (+5%) with a disk of large running torque.
2. Stand-by mode is defined at the stop condition of spindle motor and seek operation.
3. Rush current flows within 150ms after the motor start.
4. Short time peak current except for power-on surge is less than 1.3A.

9.2 Power Interface Connector and Cable

- (1) Power interface connector

(Table 15) Power interface connector

SFD side connector	HONDA TSUSHIN KOGYO Co. Ltd., P/N Z-419E or equivalent
Pin numbers	4 pins
Protection method for mis-connection	Mechanical protection by the shape of connector housing
Connector external view	See Fig.7.
Connector location	See Fig.4.
Power interface connections	See Table 16.
Cable side matched connector	AMP P/N 171822-4 (natural color) or equivalent
Cable side matched pin	AMP P/N 170204-2 (AWG#20~26, loose piece) or P/N 170262-2 (AWG#20~26, strip form) or equivalent

- (2) Power interface cable : Any appropriate cables taking the maximum power consumption of the SFD will be acceptable.

(Table 16) Power interface pin-assignment

Power voltage	Pin numbers
DC+5V	1
0V	2
(0V)	3
(No connection)	4

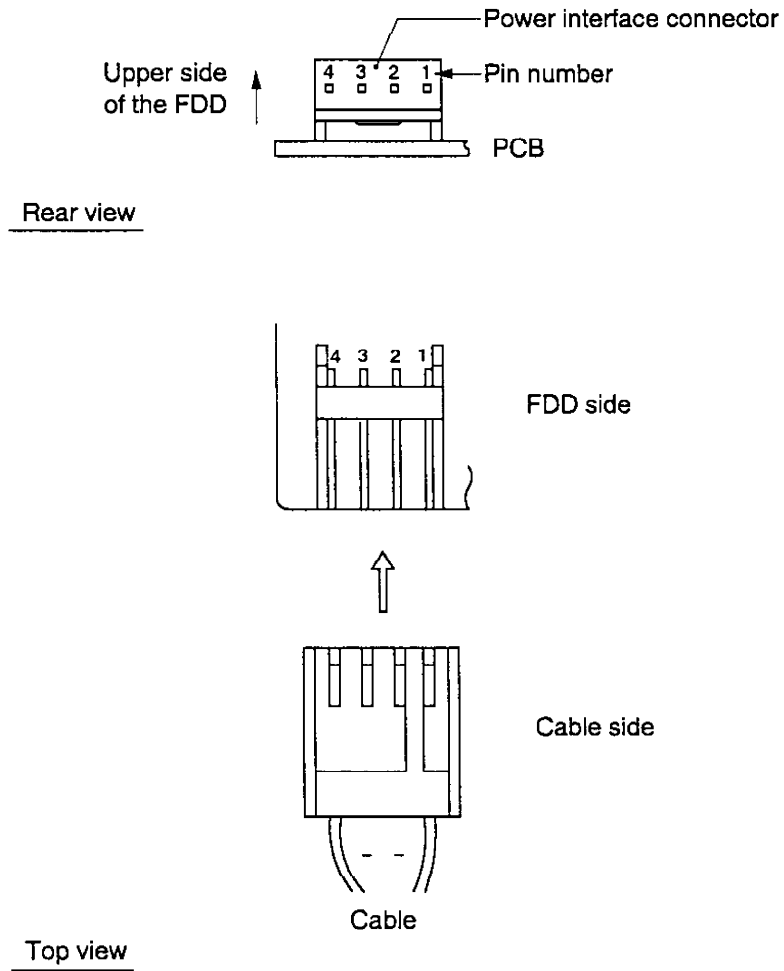

(Fig.7) Power interface connector external view

10. SIGNAL INTERFACE

10.1 Electrical Characteristics

- Notes: 1. The specifications are applicable at the SCSI connector.
 2. Vcc indicates the +5V supply voltage to be fed to the SFD.

(Table 17) SFD side I/O circuit

I/O circuit		See Fig.8-11	
Electrical characteristics of I/O circuit	Input signal level	logic"1" (TRUE)	0~0.8V
		logic"0" (FALSE)	2.0V~5.25V
	Output signal level	logic"1" (TRUE)	0~0.5V
		logic"0" (FALSE)	2.0V~5.25V
	Maximum load current receiver		-0.4mA (excluding terminator current)
	Output driver sink current		48mA (low level voltage: 0.5V)
	Terminator		220Ω ± 5% (at DC +5V side) 330Ω ± 5% (at 0V side) (Terminator is detachable)
	TERMPWR output signal	Output voltage	4.2~5.25V
		Maximum output current	1.0A
		Output current limitation	Fuse (1.0A)

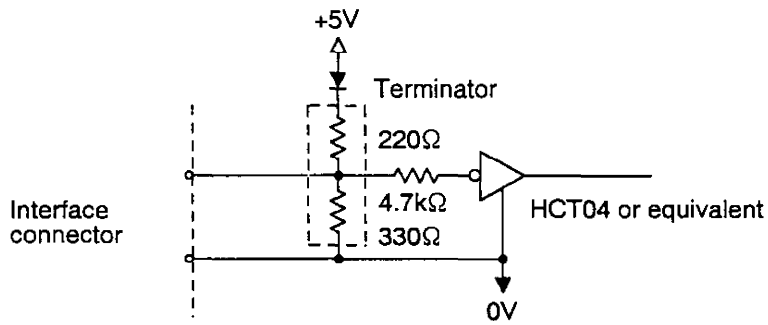

(Fig.8) RESET input circuit

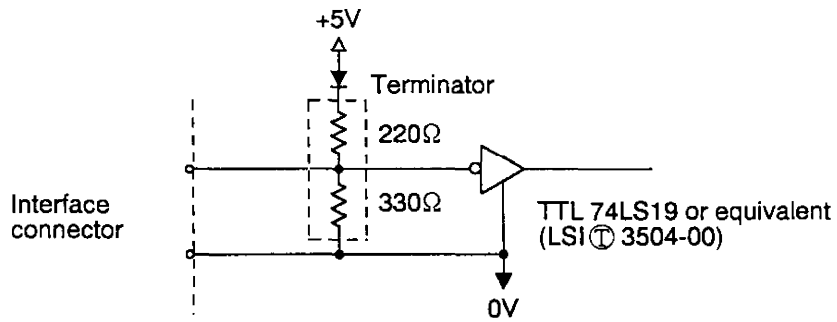

(Fig.9) Other input circuit

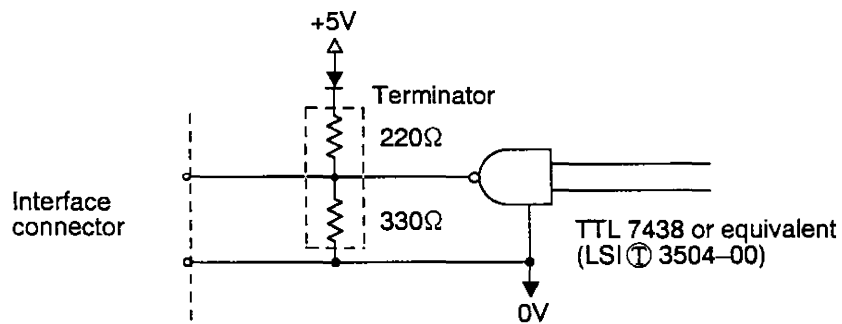

(Fig.10) Output circuit

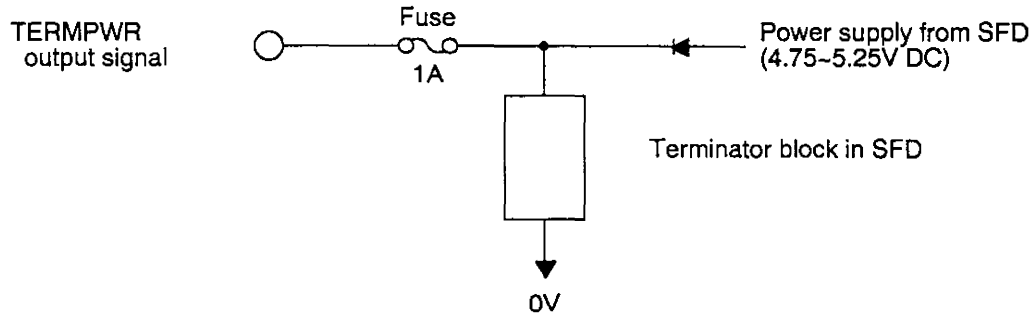

(Fig.11) TERMPWR output circuit

10.2 Sigani Interface Connector and Cable

(1) Signal interface connector

(Table 18) Signal interface connector

SFD side connector	IRISO ELECTRONICS Co., Ltd. IMSA-6032B-2-49Z015-GF or equivalent
Pin numbers and pin pitch	2 rows of 25 poles (49 poles), 2.54mm(0.1 in) pitch
Interface connection	See Table 20
Cable side matched connector	FUJITSU, P/N FCN-747B034-AU/B (closed end) or -AU/O (daisy chain) or equivalent.
Cable side mis-insertion protection key	FUJITSU, P/N FCN-707J050-AU/O or equivalent.
Connector location	See Fig.4

(2) Signal interface cable

(Table 19) Signal interface cable

Application cable	SUMITOMO 3M, P/N 3365-50 or equivalent
Maximum cable length	6m (20 feet)

(Table 20) Signal connector terminal number table

Terminal No.		Signal name	Symbol	Signal direction
GND	DATA			
1	2	DATA BUS 0 (LSB)	-DB0	HOST↔ FC-1
3	4	DATA BUS 1	-DB1	↔
5	6	DATA BUS 2	-DB2	↔
7	8	DATA BUS 3	-DB3	↔
9	10	DATA BUS 4	-DB4	↔
11	12	DATA BUS 5	-DB5	↔
13	14	DATA BUS 6	-DB6	↔
15	16	DATA BUS 7 (MSB)	-DB7	↔
17	18	DATA BUS PARITY	-DBP	↔
19	20	GND	GND	
21	22	GND	GND	
23	24	RESERVED	RES	
25(P.KEY)*	26	TERMINATOR POWER	TERMPWR	
27	28	RESERVED	RES	
29	30	GND	GND	
31	32	ATTENTION	-ATN	HOST → FC-1
33	34	GND	GND	
35	36	BUSY	-BSY	HOST↔ FC-1
37	38	ACKNOWLEDGE	-ACK	→
39	40	RESET	-RST	→
41	42	MESSAGE	-MSG	←
43	44	SELECT	-SEL	↔
45	46	CONTROL/DATA	-C/D	←
47	48	REQUEST	-REQ	←
49	50	INPUT/OUTPUT	-I/O	←

- Notes: 1. Signals are all TRUE at low level.
2. Terminals with odd numbers are all GND except for terminal No.25 (free to protect mis-insertion), No.23 and No.27 (Reserved).

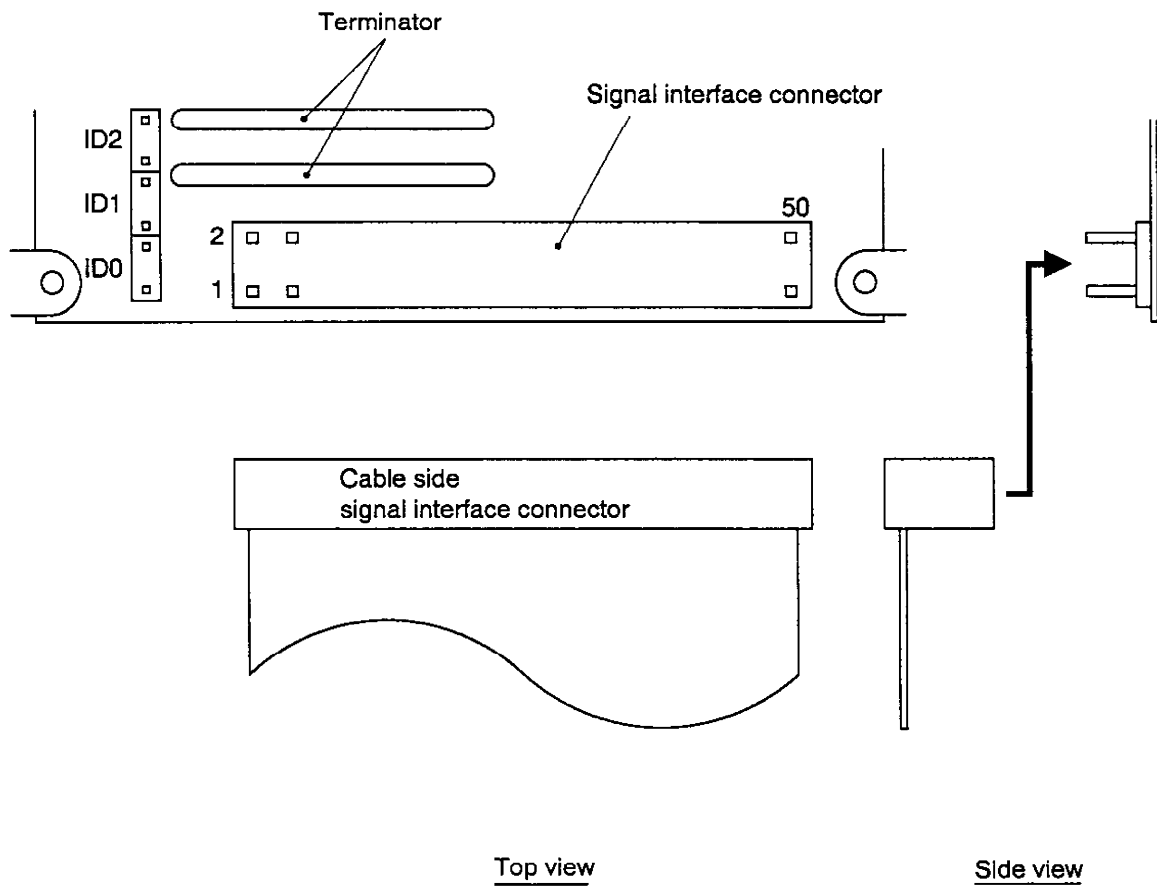

(Fig.12) Signal interface connector external view

10.3 Input and Output Signals

For the signals indicated below, an input signal represents a signal transmitted to FC-1 and an output signal, a signal transmitted from FC-1.

Input/output signal represents a bidirectional signal. All the signals are TRUE at low level.

- (1) **BUSY (-BSY):** input/output signal

This signal is used in the following three ways.

- (a) This signal goes true when the SCSI interface bus is in use.
- (b) If the FC-1 attempts to gain control of the SCSI bus in the arbitration phase, this signal goes true.
- (c) This signal is a response signal to the -SEL signal from the host system or the SFD in the selection phase and reselection phase.

- (2) **SELECT (-SEL):** input/output signal

This is to select one out of the devices on the interface bus. The selected device responds with its -BSY signal turned to TRUE. Device address information is delivered to -DB0 ~ -DB7 together with this signal.

- (3) **CONTROL/DATA (-C/D):** output signal

Indicates the type of information to be transferred through -DB0 ~ -DB7.

Control information is transferred when this signal is TRUE and data information when it is FALSE.

- (4) **INPUT/OUTPUT (-I/O):** output signal

Indicates direction of the information transferred through -DB0 ~ -DB7.

Transfer takes place from FC-1 to the host system when this signal is TRUE and from the host system to FC-1 when it is FALSE.

- (5) **MESSAGE (-MSG):** output signal

This signal is turned to TRUE in the MESSAGE Phase where information is exchanged between the host system and FC-1. The direction of message transfer is indicated by the I/O signal.

- (6) **REQUEST (-REQ):** output signal

Controls transfer timing at which the information is transferred through -DB0 ~ -DB7 (for hand-shake control) and is a data transfer request signal.

- (7) **ACKNOWLEDGE (-ACK):** input signal

Controls transfer timing at which the information is transferred through -DB0 ~ -DB7 (for hand-shake control) and is a response signal to the -REQ signal.

- (8) **ATTENTION (-ATN):** input signal

Requests reception of a message sent from the host system. MESSAGE OUT Phase is executed when FC-1 receives this signal.

- (9) **RESET (-RST):** input signal

Restores the initial state of FC-1. This signal must have a $25\mu\text{s}$ or more pulse width.

Within 800ns after this signal becomes TRUE, the FC-1 enters BUS FREE phase. However, the response time (point ⑤ onward in Fig.10-18) to the FC-1 initiator selection will be in the following condition maximum 3.3sec after this signal becomes TRUE.

- (a) While WRITE/READ-related commands are in execution, duration lasts until the data in the buffer memory (31KB) becomes empty or full.
- (b) The initial state operation of the FC-1 after (a) is over.
Therefore, if blocks that exceed 31KB are specified to the FC-1 in WRITE command and the RESET signal becomes true during processing, part of the data may not be processed.

- (10) **DATA BUS 0-7 (-DB0 ~ -DB7):** input/output signal

8-bit bidirectional bus for mutual transfer of control and data information. -DB7 is the MSB

- (Most Significant Bit) and -DB0 the LSB (Least Significant Bit).
- (11) DATA BUS PARITY (-DBP): input/output signal
Parity signal for -DB0 ~ -DB7 signals. When information is sent from FC-1, it is set up as odd parity and output with the same timing as -DB0 ~ -DB7.
When FC-1 receives information, whether parity checking (odd parity) should be done or not can be selected by setting a switch in FC-1.

10.4 Phase Sequence

This interface consists of the following operation phases.

- (a) BUS FREE Phase
- (b) ARBITRATION Phase
- (c) SELECTION Phase
- (d) RESELECTION Phase
- (e) COMMAND Phase
- (f) DATA Phase
- (g) STATUS Phase

The phase sequences are shown in Fig.13. There are sequences with and without ARBITRATION. The commands for FC-1 are executed with the sequences shown in Fig.13, though DATA Phase may not be available for some commands. Even for a command with data transfer, DATA Phase may not be available or may be discontinued depending on error information.

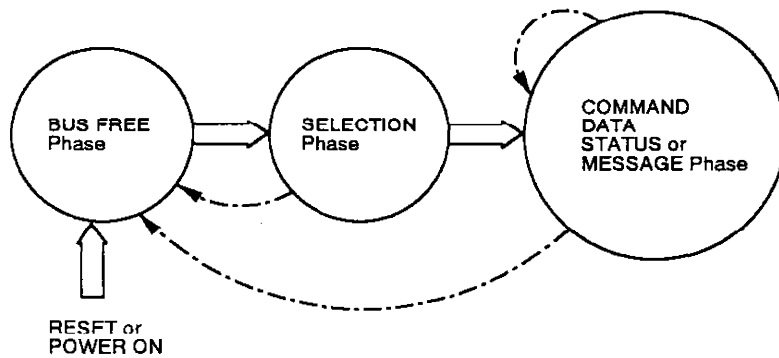

Host system without ARBITRATION

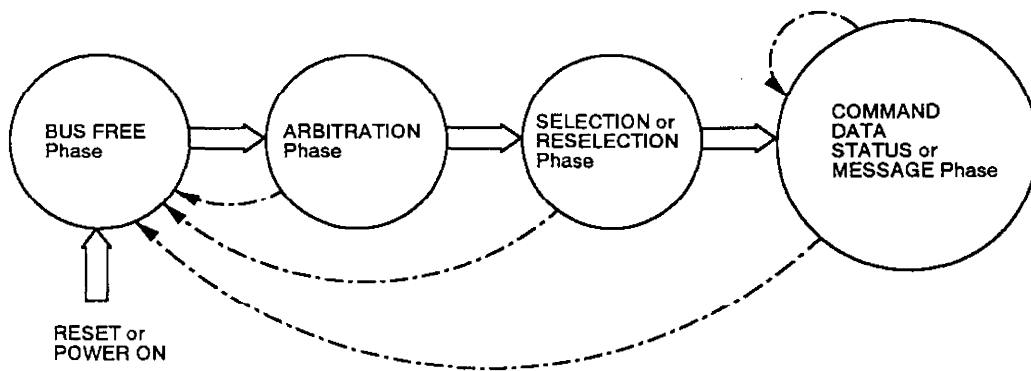

Host system with ARBITRATION

(Fig.13) Phase sequence

10.5 Interface Timing

The following specifications are all applied to the ends of the FC-1 interface connectors.

- | | |
|-------------------------------|----------|
| (1) RESET timing | : Fig.14 |
| (2) BUS FREE Phase timing | : Fig.15 |
| (3) ARBITRATION Phase timing | : Fig.16 |
| (4) SELECTION Phase timing | : Fig.17 |
| (5) RESELECTION Phase timing | : Fig.18 |
| (6) COMMAND Phase timing | : Fig.19 |
| (7) DATA IN Phase timing | : Fig.20 |
| (8) DATA OUT Phase timing | : Fig.21 |
| (9) STATUS Phase timing | : Fig.22 |
| (10) MESSAGE IN Phase timing | : Fig.23 |
| (11) MESSAGE OUT Phase timing | : Fig.24 |

In Fig.14 to Fig.24, 'H' denotes high level (logic '0' FALSE) and 'L', low level (logic '1' TRUE).

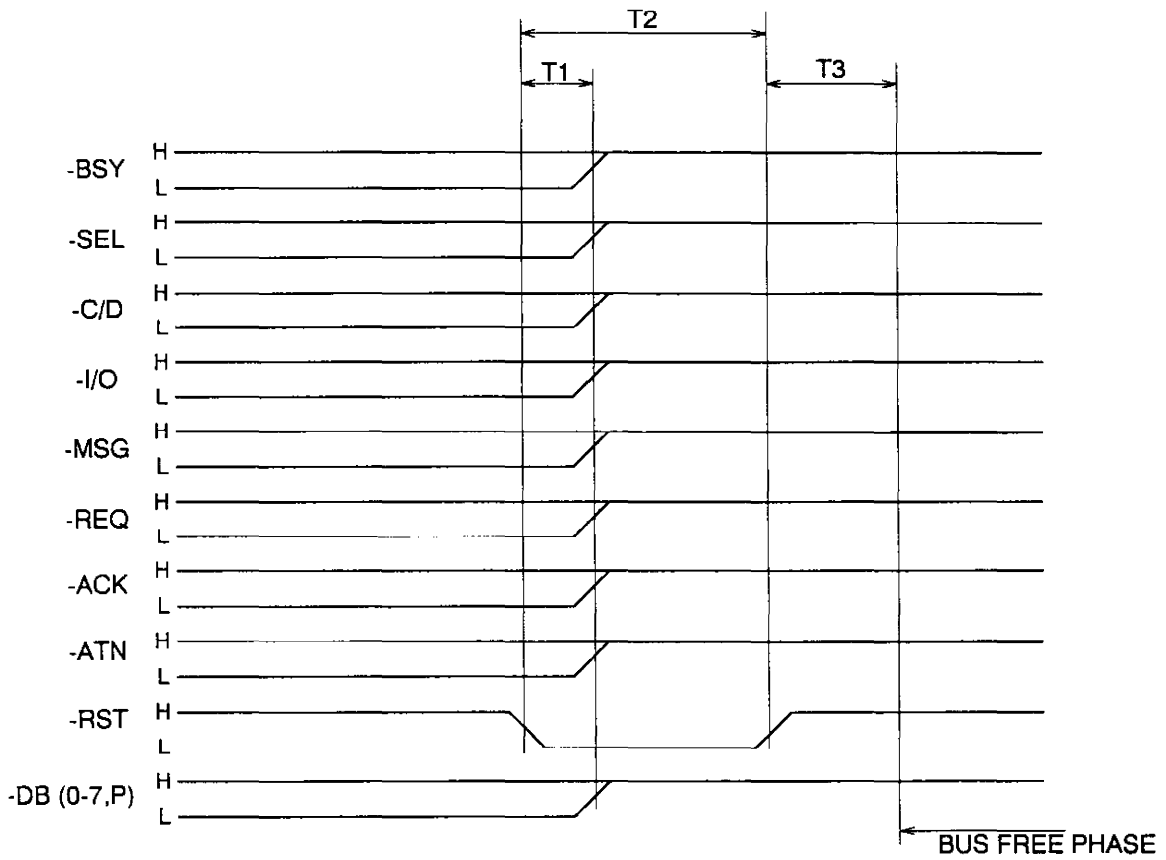

Symbol	Description of symbol	MIN.	TYP.	MAX.	Unit
T1	BUS CLEAR DELAY			800	ns
T2	RESET HOLD	25			μ s
T3	BUS SETTLE DELAY	400			ns

(Fig.14) RESET timing

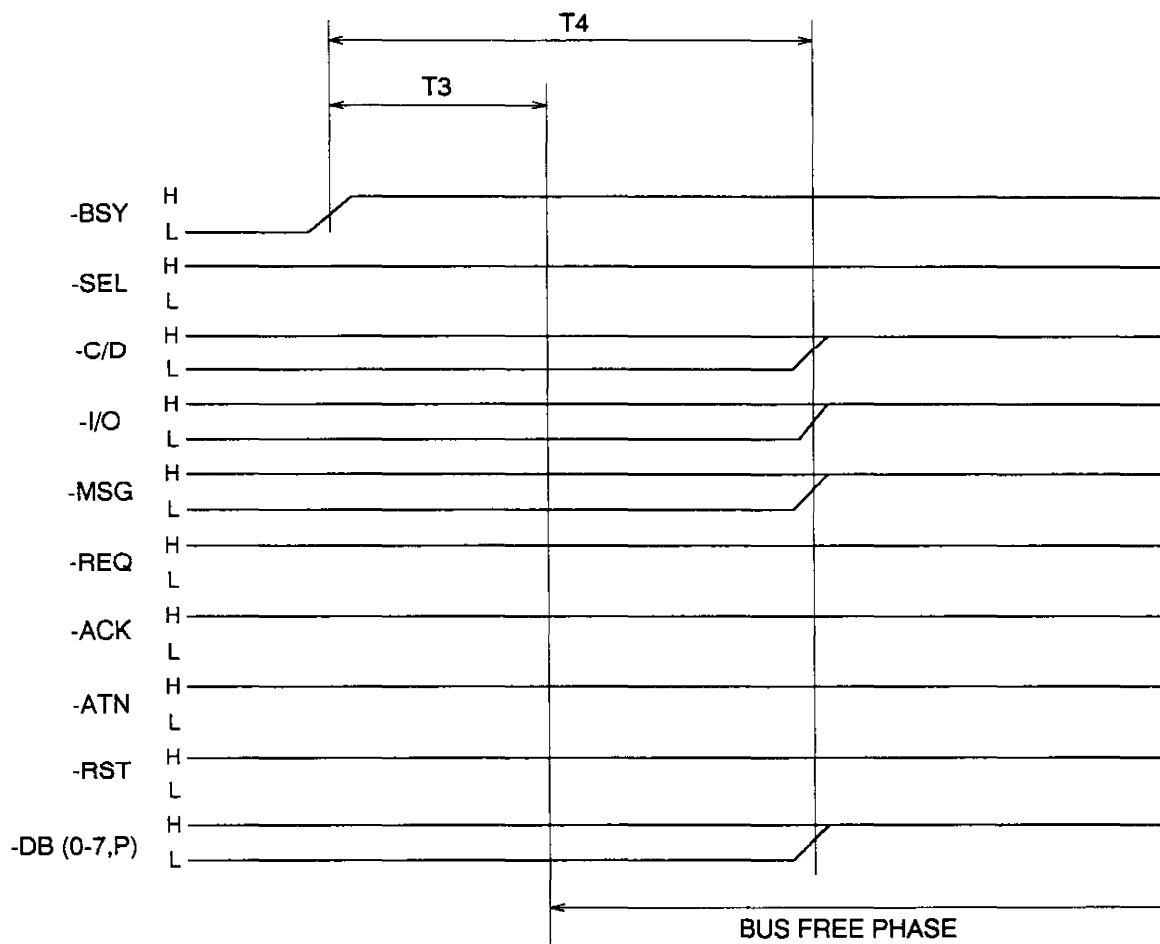

Symbol	Description of symbol	MIN.	TYP.	MAX.	Unit
T3	BUS SETTLE DELAY	400			ns
T4	T3 + BUS CLEAR DELAY			1.2	μ s

(Fig.15) BUS FREE PHASE timing

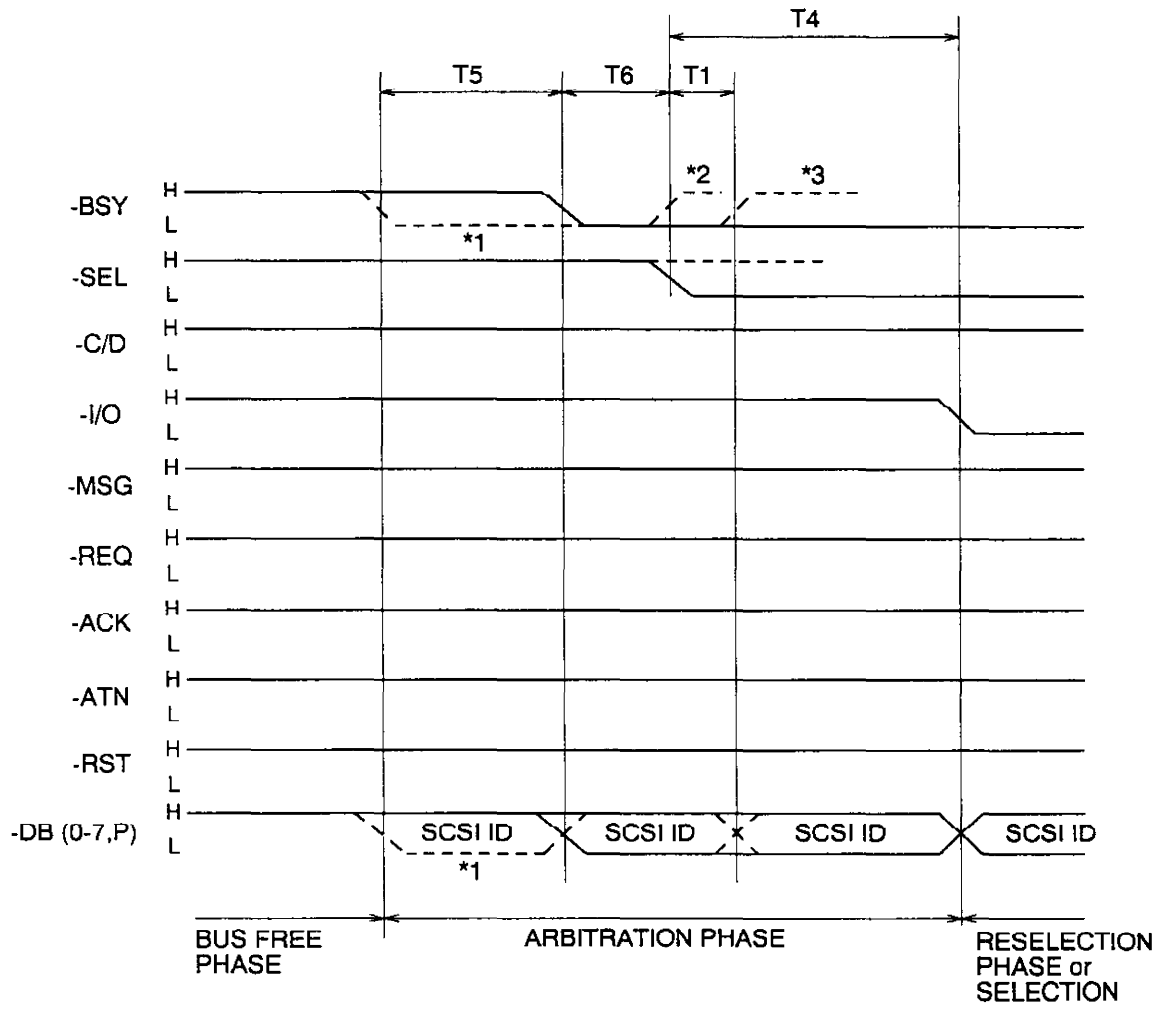

Symbol	Description of symbol	MIN.	TYP.	MAX.	Unit
T1	BUS CLEAR DELAY			800	ns
T4	BUS SETTLE + BUS CLEAR	1.2			μ s
T5	BUS FREE DELAY	800		1800	ns
T6	ARBITRATION DELAY	2.2			μ s

- Notes:
1. Broken line *1 indicates the case in which a -BSY signal is already sent from another SCSI device and its ID bit is sent to the data bus.
 2. Broken line *2 indicates the case in which an ID bit with higher order than itself is sent to the data bus. Data bus drive is discontinued at the same time.
 3. T1 and the broken line *3 indicate the case in which the FC-1 takes part in the ARBITRATION and a SEL signal is transmitted from another SCSI device before inspection of -DB0 ~ -DB7. Data bus drive is discontinued at the same time.

(Fig.16) ARBITRATION PHASE timing

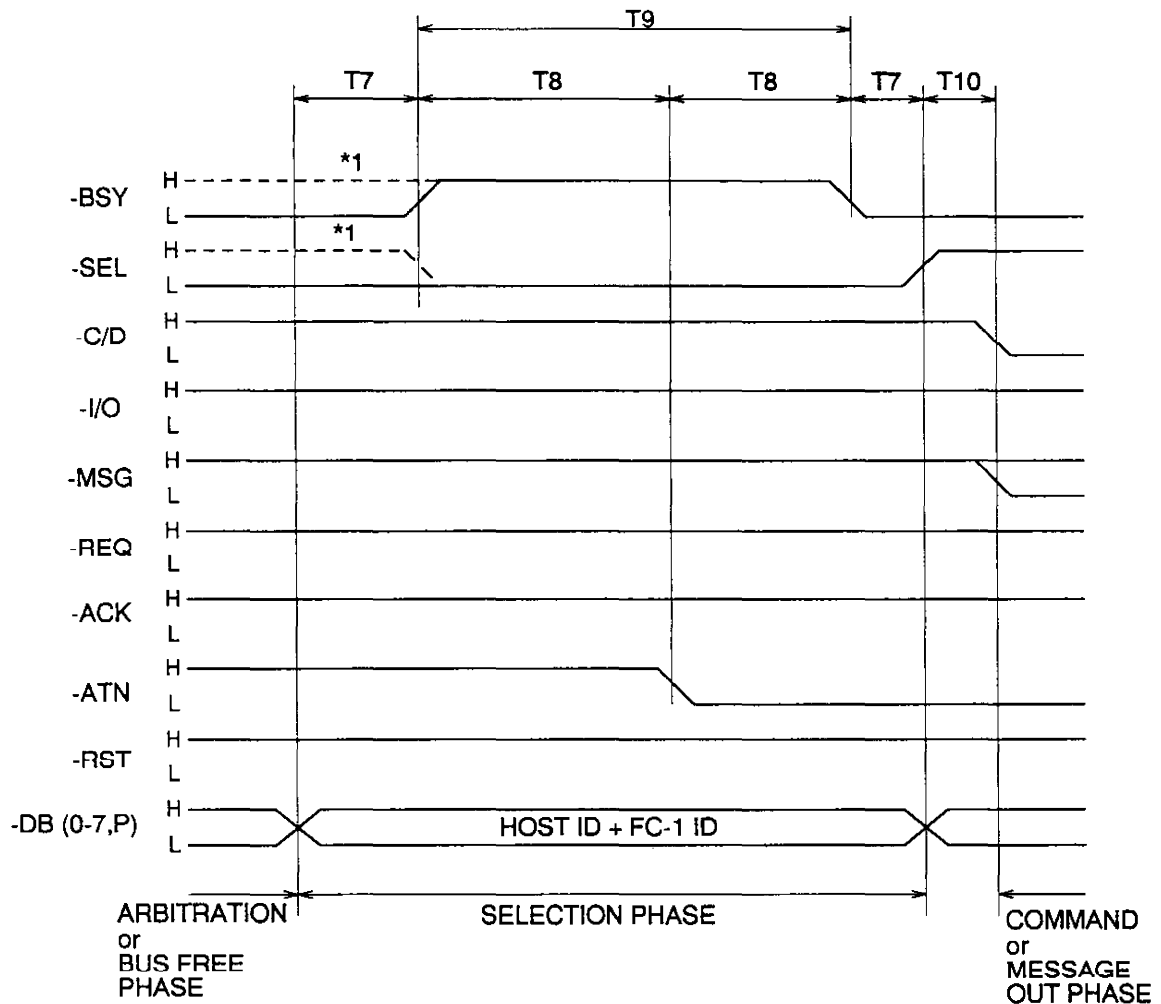

Symbol	Description of symbol	MIN.	TYP.	MAX.	Unit
T7	(DESKEW DELAY) × 2	90			ns
T8		0			ns
T9	BUS SETTLE DELAY	0.4		200	μs
T10		25			μs

*2

- Notes: 1. Broken line *1 indicates the case in which this phase has been entered after BUS FREE PHASE (without ARBITRATION).
 2. MAX. on *2 indicates a selection abort time.

(Fig.17) SELECTION PHASE timing

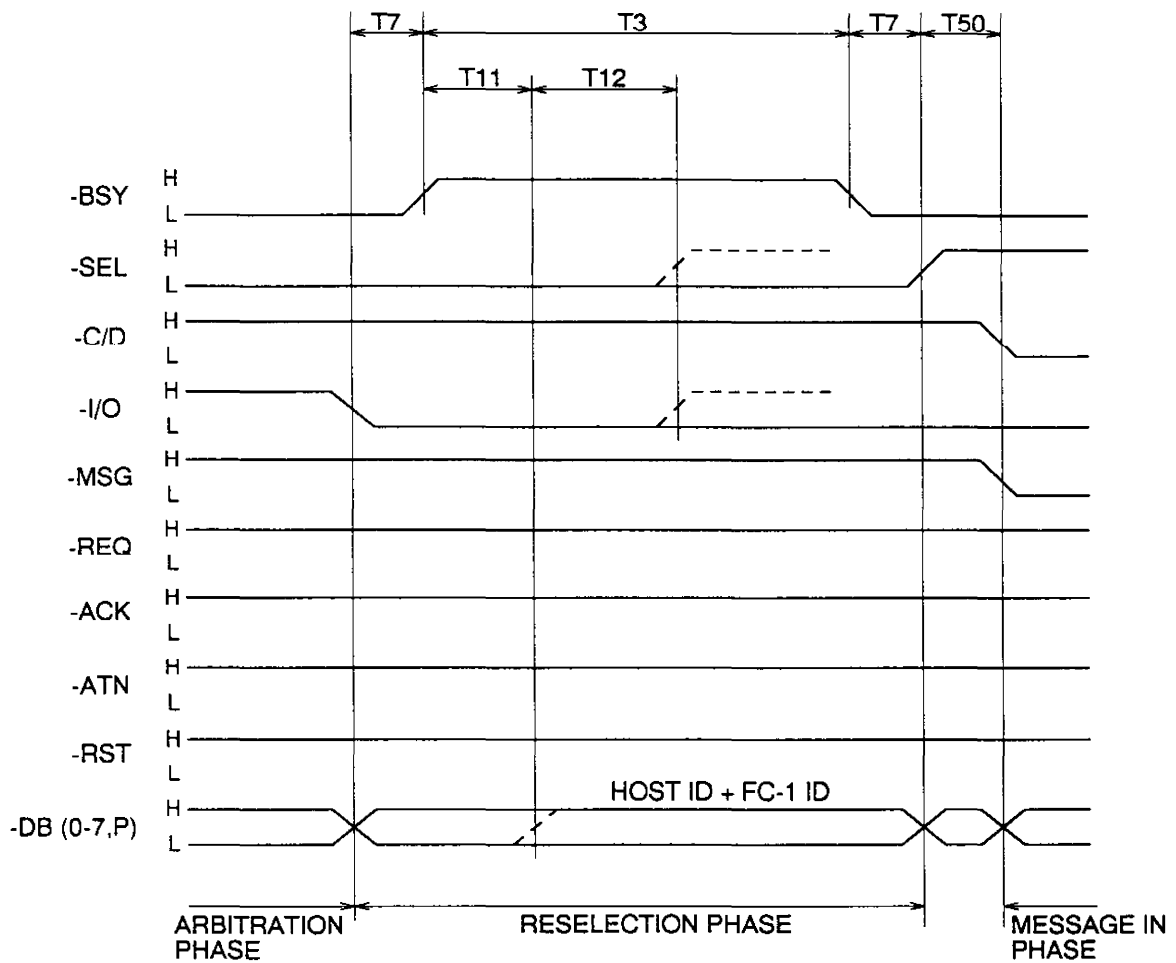

Symbol	Description of symbol	MIN.	TYP.	MAX.	Unit
T3	BUS SETTLE DELAY or SELECTION TIMEOUT	400ns		200 μ s	
T7	(DESKEW DELAY) \times 2	90			ns
T50		65			μ s
T11	SELECTION TIMEOUT	250			ms
T12	SELECTION ABORT TIME + (DESKEW DELAY) \times 2	200.09			μ s

Note: T11, T12 and the broken line indicate the case in which there is no -BSY response from the host (timeout).

(Fig.18) RESELECTION PHASE timing

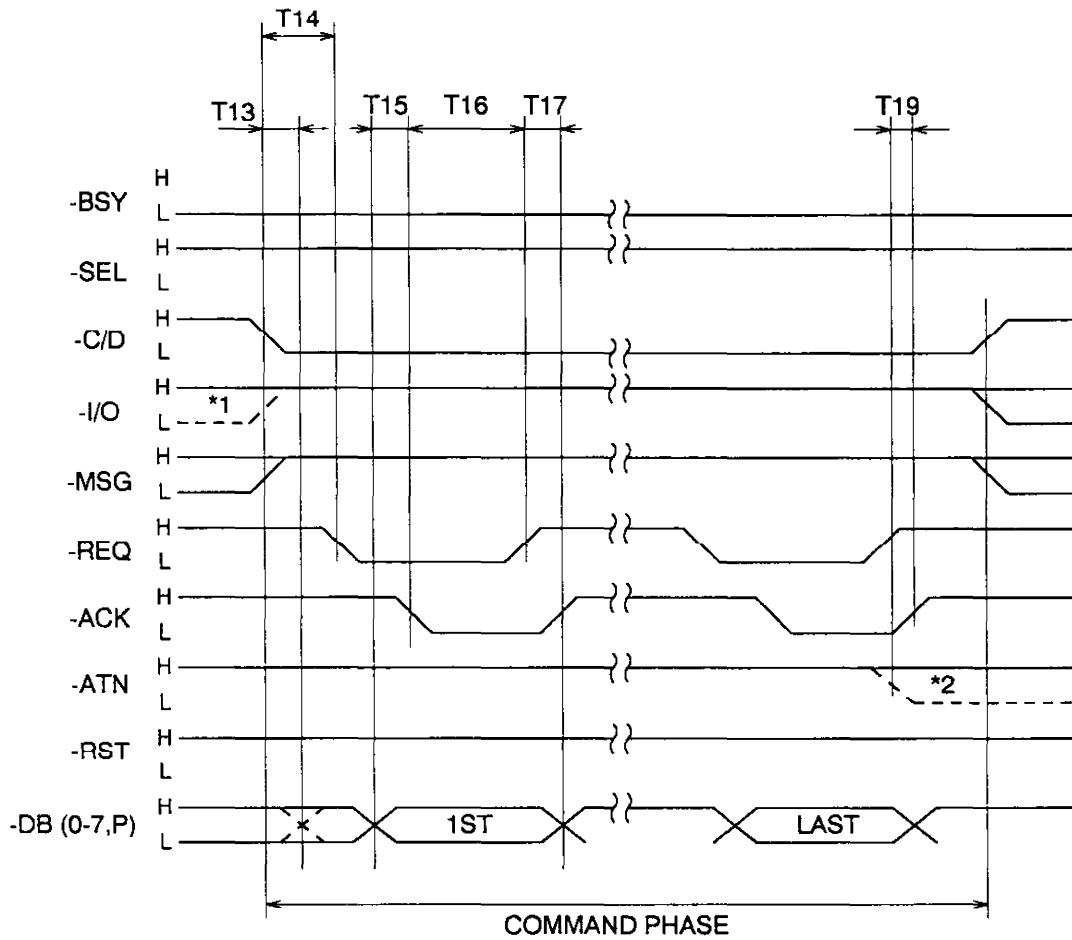

Symbol	Description of symbol	MIN.	TYP.	MAX.	Unit
T13	DESKEW DELAY			45	ns
T14	BUS SETTLE DELAY + DATA RELEASE DELAY	800			ns
T15	DESKEW DELAY + CABLE SKEW	55			ns
T16		0			ns
T17		0			ns
T19		0			ns

- Notes:
1. For the broken line *1, the FC-1 frees the data bus at the timing of T13.
 2. The broken line *2 indicates the timing at which the host transmits an -ATN signal in this phase.

(Fig.19) COMMAND PHASE timing

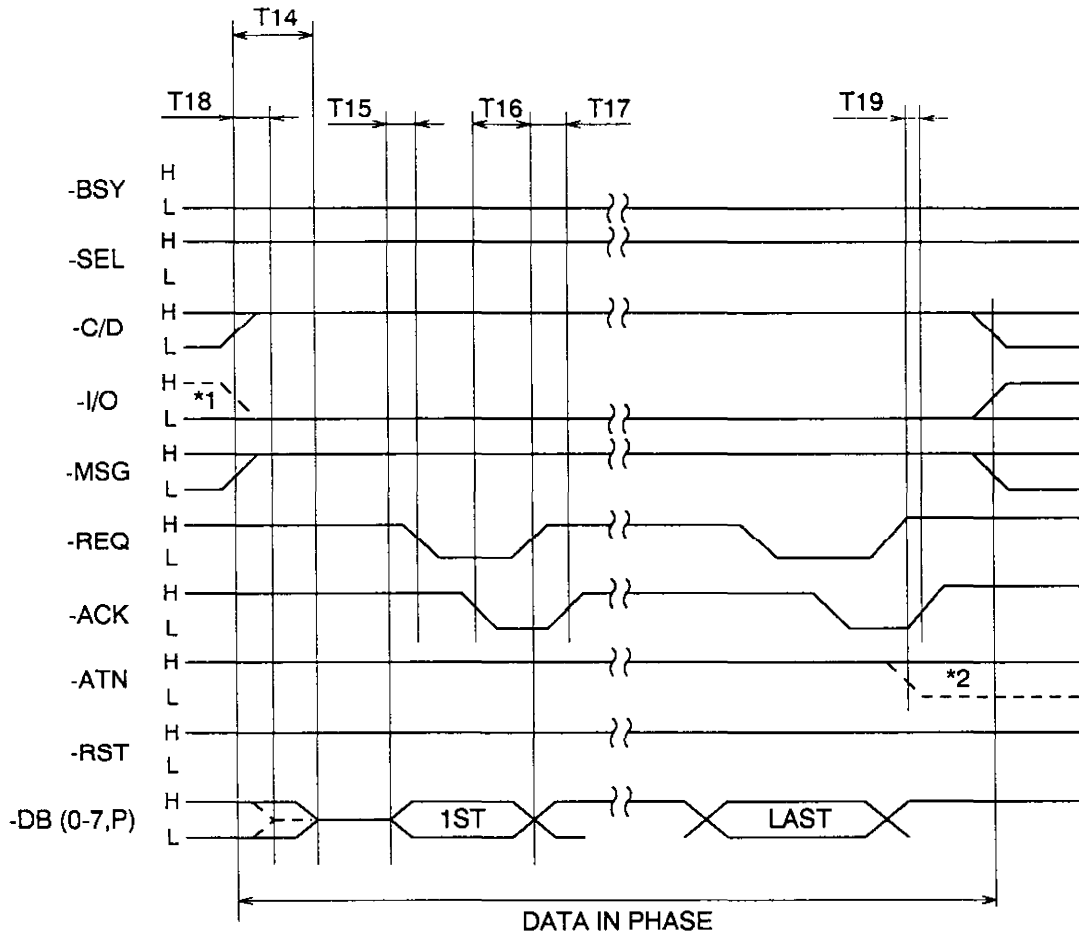

Symbol	Description of symbol	MIN.	TYP.	MAX.	Unit
T14	BUS SETTLE DELAY + DATA RELEASE DELAY	800			ns
T15	DESKEW DELAY + CABLE SKEW	55			ns
T16		0	70		ns
T17		0			ns
T18	DATA RELEASE DELAY			400	ns
T19		0			ns

- Notes:
1. For the case of the broken line *1, the host must free the data bus at the timing of T18. At this time, the FC-1 drives the data bus after (T18 or T14) + internal processing time.
 2. The broken line *2 indicates the timing at which an -ATN signal is transmitted at the end of this phase.

(Fig.20) DATA IN PHASE timing

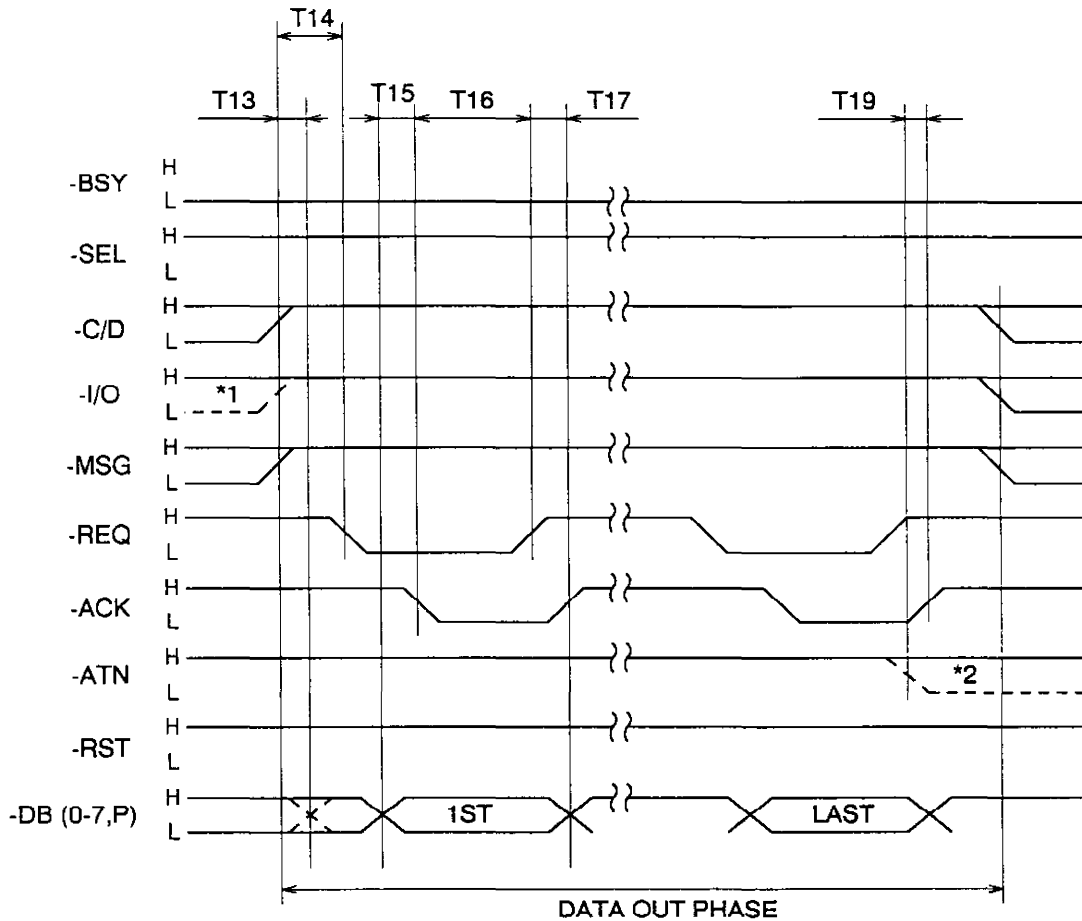

Symbol	Description of symbol	MIN.	TYP.	MAX.	Unit
T13	DESKEW DELAY			45	ns
T14	BUS SETTLE DELAY + DATA RELEASE DELAY	800			ns
T15	DESKEW DELAY + CABLE SKEW	55			ns
T16		0	70		ns
T17		0			ns
T19		0			ns

- Notes:
1. For the case of the broken line *1, the FC-1 frees the data bus at the timing of T13.
 2. The broken line *2 indicates the timing at which an -ATN signal is transmitted in this phase.

(Fig.21) DATA OUT PHASE timing

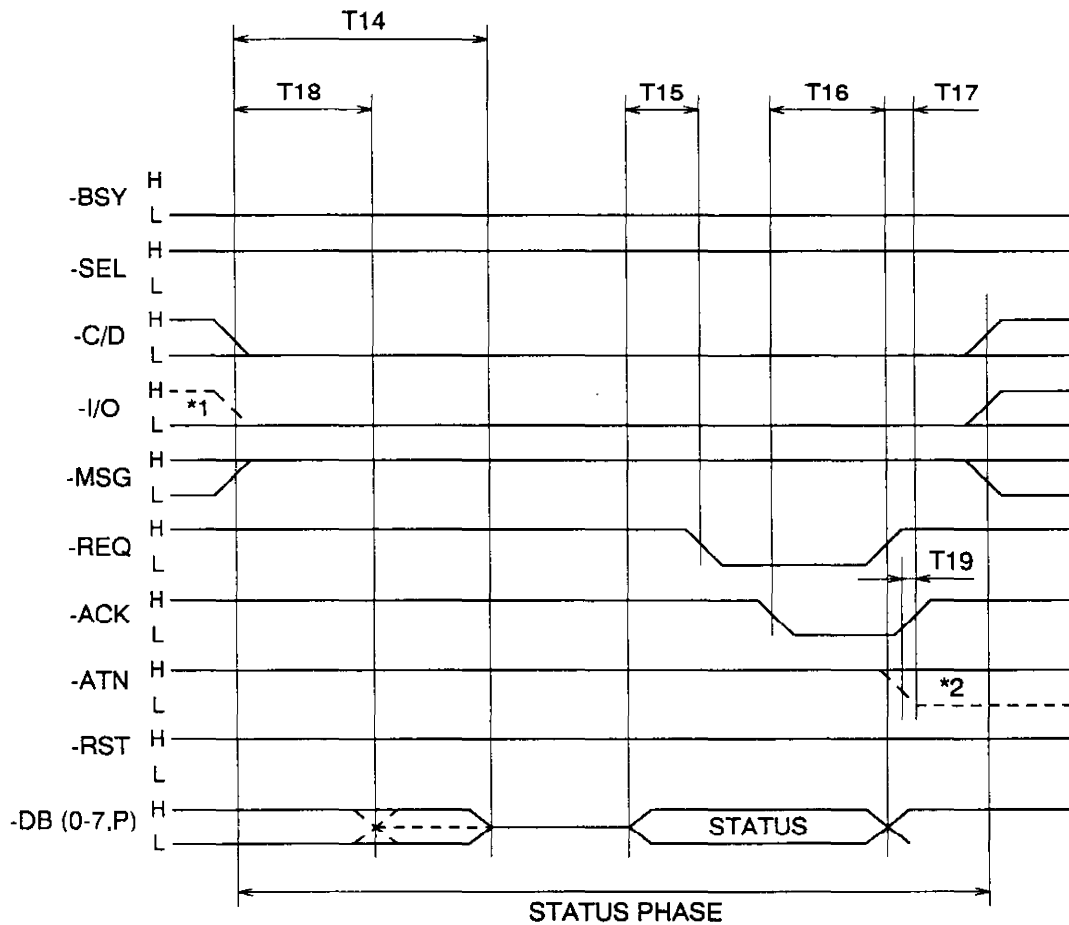

Symbol	Description of symbol	MIN.	TYP.	MAX.	Unit
T14	BUS SETTLE DELAY + DATA RELEASE DELAY	800			ns
T15	DESKEW DELAY + CABLE SKEW	55			ns
T16		0	70		ns
T17		0			ns
T18	DATA RELEASE DELAY			400	ns
T19		0			ns

- Notes:
1. For the case of the broken line *1, the host must free the data bus at the timing of T18. At this time, the FC-1 drives the data bus after (T14 or T18) + internal processing time.
 2. The broken line *2 indicates the timing at which an -ATN signal is transmitted at the end of this phase.

(Fig.22) STATUS PHASE timing

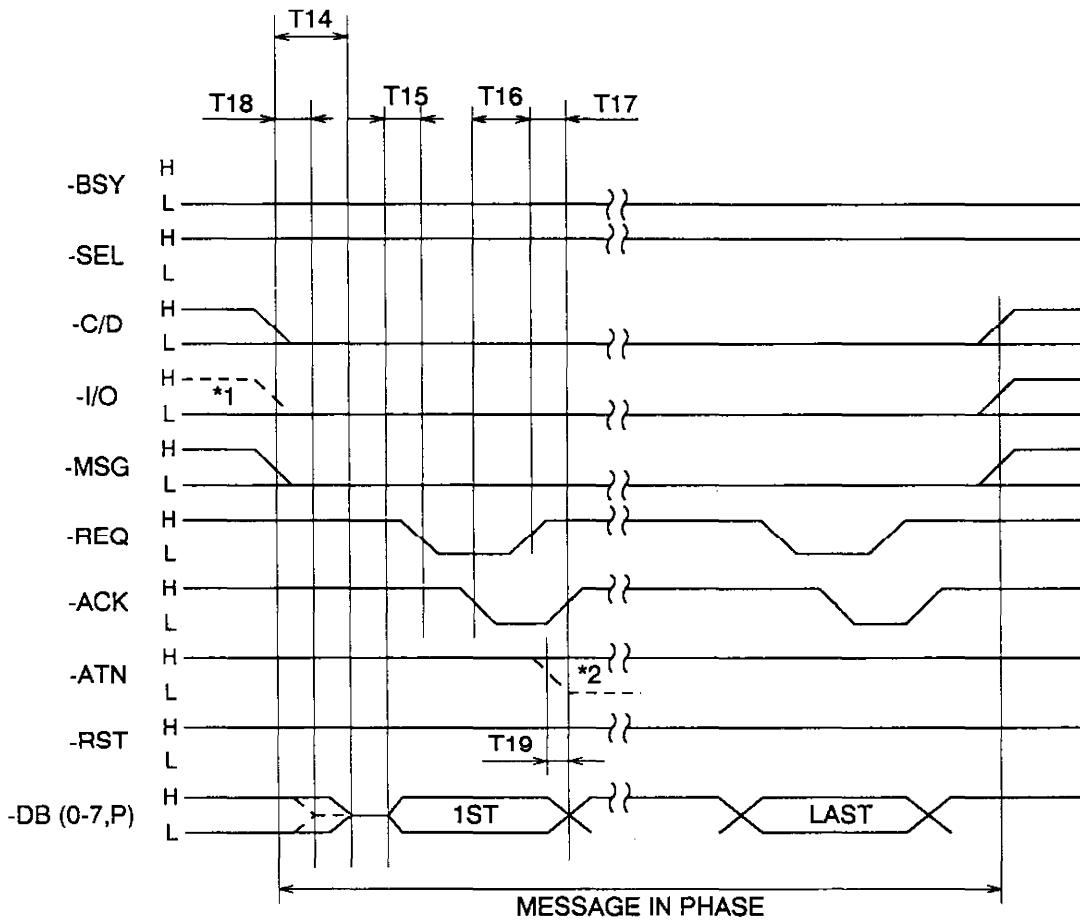

Symbol	Description of symbol	MIN.	TYP.	MAX.	Unit
T14	BUS SETTLE DELAY + DATA RELEASE DELAY	800			ns
T15	DESKEW DELAY + CABLE SKEW	55			ns
T16		0	70		ns
T17		0			ns
T18	DATA RELEASE DELAY			400	ns
T19		0			ns

- Notes:
1. For the case of the broken line *1, the host must free the data bus at the timing of T18. At this time, the FC-1 drives the data bus after (T14 or T18) + internal processing time.
 2. The broken line *2 indicates the timing at which an -ATN signal is transmitted when the host requests re-transfer of the MESSAGE.

(Fig.23) MESSAGE IN PHASE timing

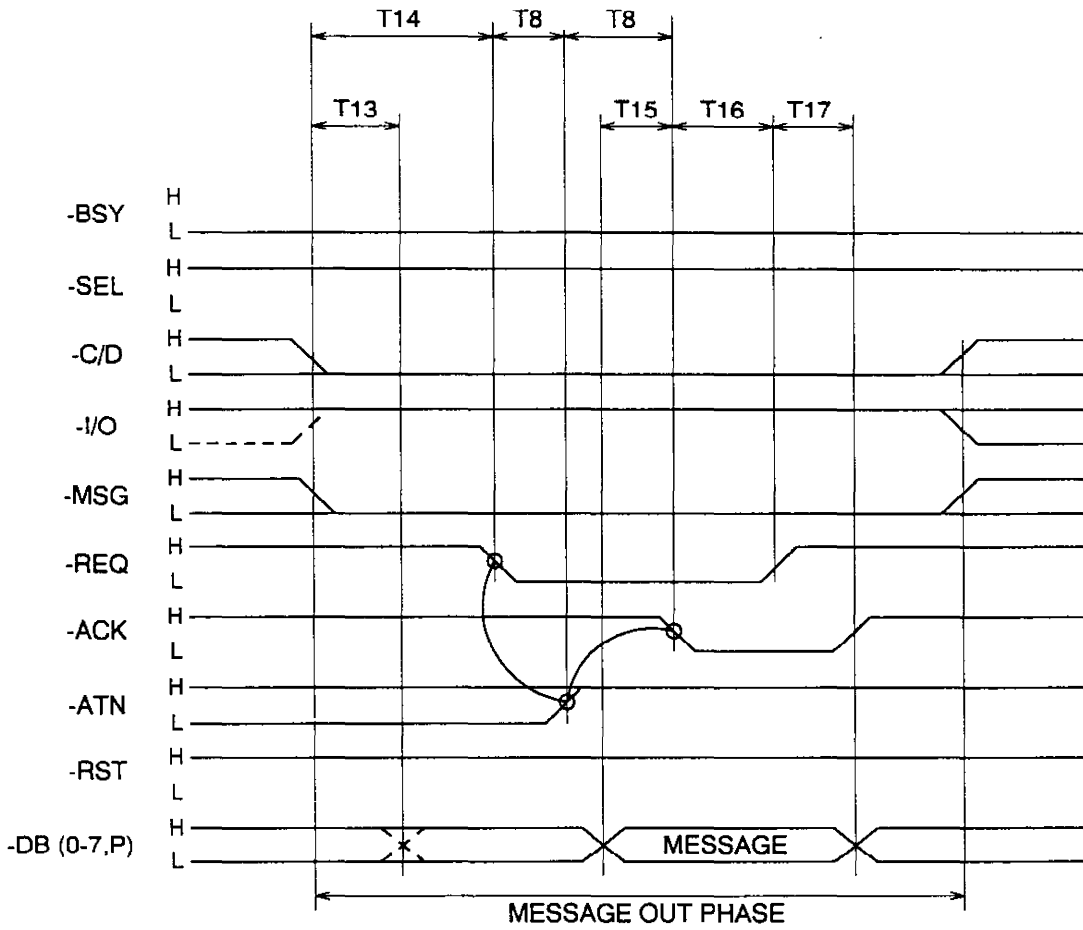

Symbol	Description of symbol	MIN.	TYP.	MAX.	Unit
T8		0			ns
T13	DESKEW DELAY			45	ns
T14	BUS SETTLE DELAY + DATA RELEASE DELAY	800			ns
T15	DESKEW DELAY + SKEW	55			ns
T16		0	70		ns
T17		0			ns

Note: For the case of the broken line, the FC-1 frees the data bus at the timing of T13.

(Fig.24) MESSAGE OUT PHASE timing

10.6 Control Sequence

10.6.1 Initialized state when the power is switched on or reset

(1) Protection of written data

In the transient period when the +5V power is lower than 3.5V, the SFD is protected against miswriting and miserasing whatever the state of input signals are.

(2) Auto-recalibration

Auto-recalibration is executed (head moves to track 00) immediately after the power-on or reset.

(3) Motor starting state

The moment the unit is bootstrapped, the motor turns ON. However, it stops five seconds later. The subsequent control is performed by the command from the host.

(4) Self-diagnosis

The moment the power is switched on or reset, the following items are checked. In the event of an abnormality, **HARDWARE ERROR (ADDITIONAL SENSE CODE = A0 - A2h)** is issued in response to the command given first, terminating in a check condition. If control is continued disregarding this, operation is not guaranteed.

(a) Read/write check of the buffer RAM and I/O port

(b) Specified check of straps

(c) Check of whether or not terminator power is supplied

(5) Mode select state

In the initialized state, the high-density mode is set.

Operation mode	:	H (2MB)
No. of sectors	:	18 sectors/track
Block length	:	512 bytes/sector
Recording method	:	MFM

If operation is to be done with the above setting, there is no need to issue a new mode select command.

(6) FC-1 reset sequence after the power is switched ON.

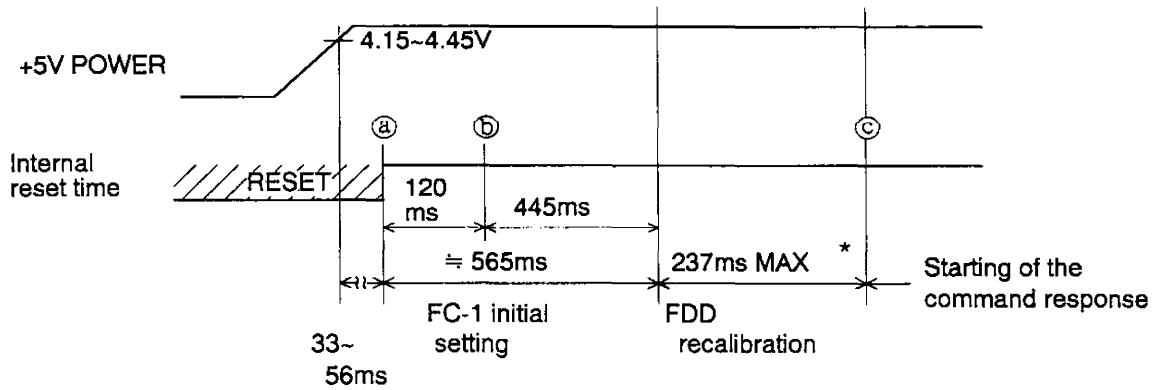

(Fig.25) Internal reset time

- Notes:
1. SFD doesn't respond to the section occurring between (a) and (b).
 2. The selection occurring between (b) and (c) shifts phases in the order STATUS (BUSY) → MESSAGE IN (COMMAND COMPLETE) → BUS FREE. When the RESET signal of SCSI turned to true at (a), the shift is the same.
 3. *: When the head position of the SFD is at track 79.

10.6.2 Disk Installation

- (1) The moment a disk is installed, the spindle motor automatically starts rotating, during which chucking of the disk hub is performed.
- (2) The auto-chucking is completed within 600ms.

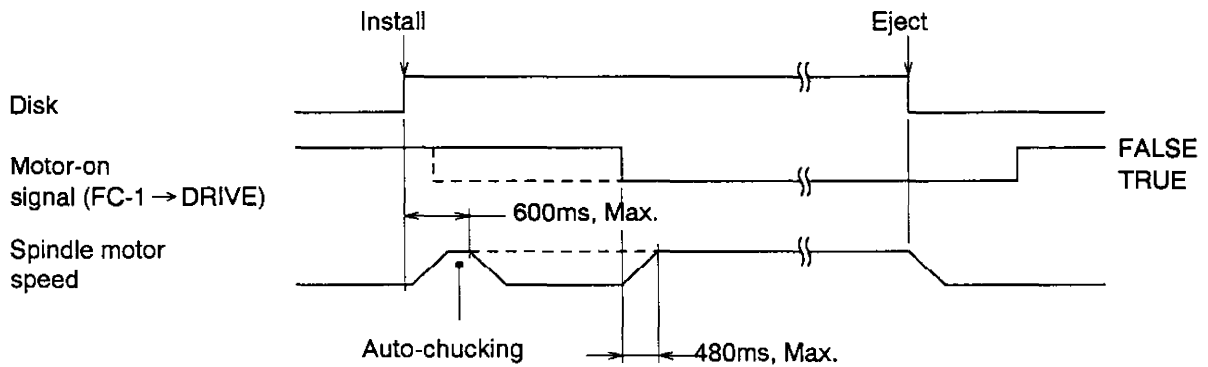

(Fig.26) Disk installation and motor rotation

10.6.3 Current consumption profile

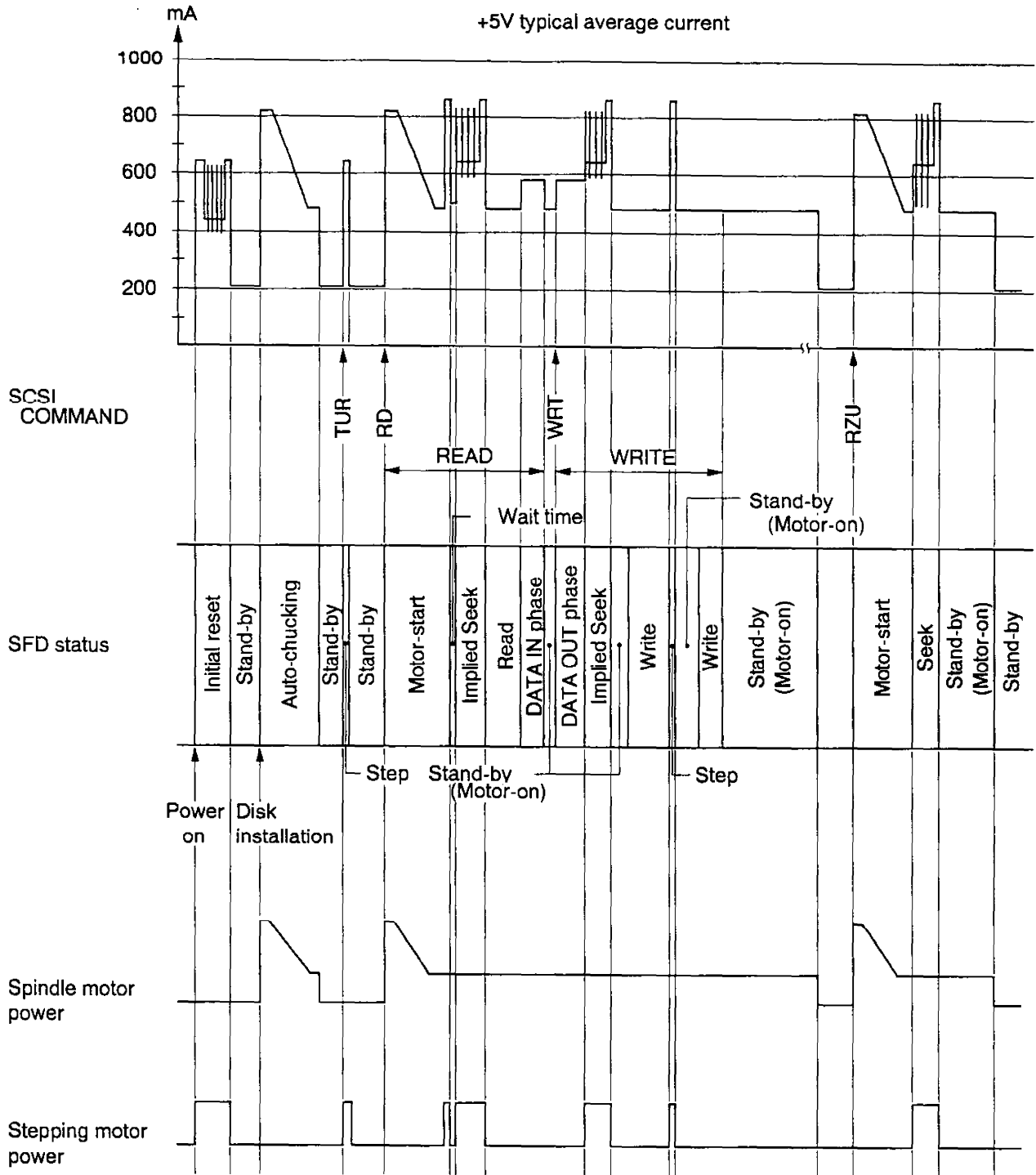

(Fig.27) Typical average current profile

10.7 Setting the Mode for the SFD

When setting the mode of this SFD, mode can be selected by one of the following two methods by using the straps on the FC-1 board and FDD main board.

10.7.1 Method A

Method A indicates that the following operation is possible and the unit is factory-preset by method A.

- (1) The initiator can detect the medium type (DD/HD) now loaded in the SFD.
- (2) Based on the result of (1), the initiator can set the mode according to the type of medium loaded.
The FC-1 can set two FDD density modes using the FDD interface signal (HD IN signal) shown in Table 21.

(Table 21) FDD density mode setting input/output signals

FDD interface signal	Signal direction	Meaning of the signal
HD IN signal	FC-1 → FDD	2MB mode setting signal
HD OUT signal	FC-1 ← FDD	HD hole identification signal

- (3) The initiator can recover in even a special case where a disk loaded is written with inherently the wrong density.
For example, read or write of HD medium written in the 1MB mode is possible though reliability is low.
- (4) Procedure

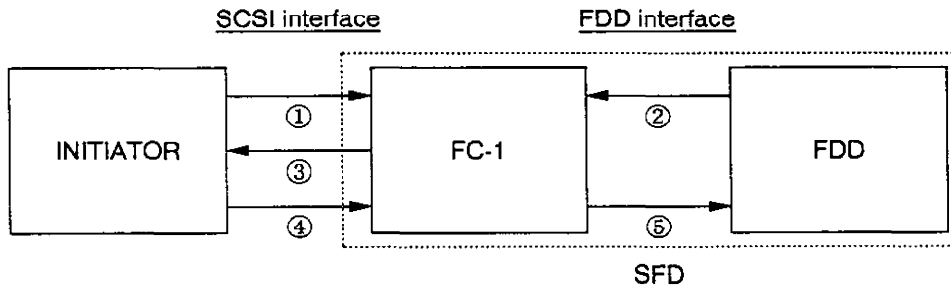

- Procedures:
- ① The initiator executes the MODE SELECT command by making the Medium Type of the HEADER section 02h (Media identification code). (when in POWER ON, SCSI RESET or DISK CHANGE)
 - ② The FC-1 sets the mode inside the FC-1 by referring to the media identification input signal (HD OUT signal) from the FDD.
 - ③ The initiator can detect the media loaded in the FDD with the HEADER section of the MODE SENSE data, Medium Type by executing the MODE SENSE command.
HD media: 88h, DD media: 80h
 - ④ The initiator executes the MODE SELECT command before the next write or read action based on the execution result of ③.
 - ⑤ The FC-1 sets the mode of the FDD (including the HD IN signal) by the MODE SELECT parameter of ④.

Note: If the initiator needs not detect the type of medium now loaded in the SFD, ① to ③ above can be omitted.

10.7.2 Method B

Method B indicates the following operations are possible.

- (1) The initiator can detect the medium type (DD/HD) now loaded in the SFD.
- (2) By identifying whether or not there is a HD hole on the disk loaded, the SFD automatically sets the 1MB (DD) or 2MB (HD) mode.
The initiator can only set mode for the SFD with respect to the PAGE parameter.
- (3) The initiator cannot rescue in a special case where a disk loaded is written with the inherently wrong density.
- (4) Procedure

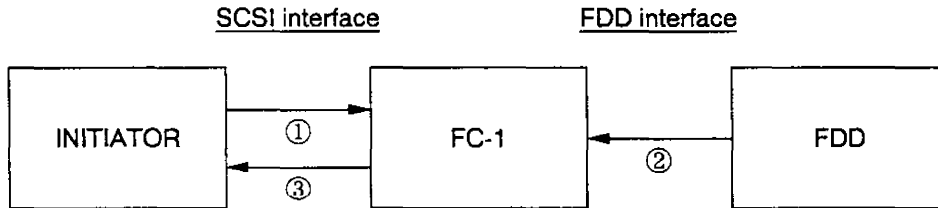

- Procedures:
- ① The initiator executes the command in the DISK LOAD status (excluding the INQUIRY and REQUEST SENSE commands).
 - ② The FC-1 sets the mode inside the FC-1 referring to the media identification input signals (HD OUT signal) from the FDD and executes the command ① based on it.
 - ③ The initiator can detect the MODE setting status (including the medium loaded in the FDD) of the current FC-1 from the MODE SENSE command. The HEADER section of the MODE SENSE data (Current rate), Medium Type is as follows.
HD media: 88h, DD media: 80h

Note: To set mode including the PAGE 5 parameter, the initiator executes the MODE SELECT command by making the Medium type of the HEADER section 00h or 02h.

10.8 Customer Selectable Straps

10.8.1 Straps setting on the FC-1 board

There are straps on the FC-1 board as shown in Fig.28 and the state where the shorting bar is inserted is the on state. Their functions are described below.

Factory-set is follows.

H, PAR, ID0 ~ ID2: ON

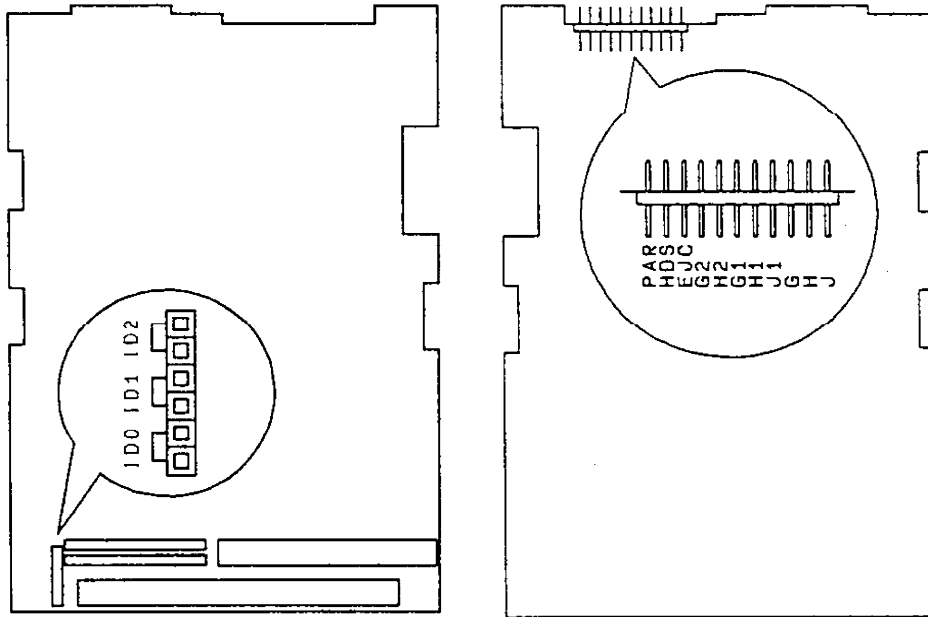

(Shown when viewed from the chip side)

(Fig.28) Straps arrangement

(1) ID Straps Setting

Performs SCSI ID setting with "ID0", "ID1", and "ID2" on the PCBA. The relation between "ID0 ~ ID2" settings and the SCSI ID addresses are shown in Table 22.

"ID0 ~ ID2" are all factory-set to "ON" (device address = 0).

(Table 22) SCSI ID setting

SCSI ID ADDRESS	ID2	ID1	ID0
0	ON	ON	ON
1	ON	ON	OFF
2	ON	OFF	ON
3	ON	OFF	OFF
4	OFF	ON	ON
5	OFF	ON	OFF
6	OFF	OFF	ON
7	OFF	OFF	OFF

(2) SCSI parity strap

"PAR" on the PCBA is the parity strap. When "PAR" is ON, the FC-1 performs parity checking (odd number) of input data (-DB0 ~ -DB7, -DBP). Parity checking does not take place when "PAR" is OFF.

It is factory-set to "ON".

(3) J/H/G/J1/H1/G1/H2/G2 straps

These straps indicate an FDD type as shown in Table 10-4 and the LUN 0 FDD type is set by J/H/G straps, the LUN 1 FDD type by J1/H1/G1 straps or the LUN 2 FDD type by H2/G2 straps. Here, the 1MB mode is valid at all times irrespective of the LUN number. Strap "H" is factory-preset to ON.

(Table 23) Setting the FDD type

Strap	G/G1/G2	H/H1/H2	J/J1
Mode	1.6MB mode	2MB mode	4MB mode

(4) HDS strap

Sets the initial state whether or not the mode auto setting function according to the disk type loaded in the SFD is valid using the HDS strap. If the HDS strap is ON, it is necessary to set the H1/H2 straps.

The strap is factory-preset to OFF.

"HDS": ON Valid
OFF Invalid

(5) EJC strap

(Setting the output signal at pin 4 in the FD IF)

Sets the initial state whether or not the media eject function is valid using the EJC strap.

The strap is factory-preset to OFF and it is not possible to change this strap.

"EJC": ON Valid
OFF Invalid

10.8.2 Strap setting on the FDD main board

The straps on the FDD main board and an outline of their functions are given in Table 24.

If the settings of straps other than HA/IR/FG on the FDD main board are changed, the operation of this SFD is not guaranteed.

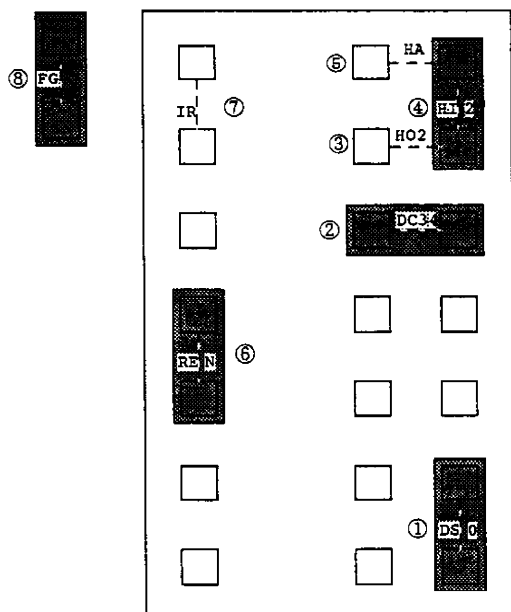

Position	Name	Outline of functions
①	DS0	DRIVE SELECT 0 input
②	DC34	PIN 34: DISK CHANGE output
③	HO2	PIN 2: HD OUT output
④	HI2	PIN 2: HD IN input
⑤	HA	Sets FDD automatic density using the HD hole
⑥	REN	Auto-recalibration enable
⑦	IR	LED active condition: DRIVE SELECT * READY state
⑧	FG	Frame ground

Note: The shaded positions are the factory-preset positions.

(Table 24) Straps on the FDD main board and their functions

(1) HA/HI2/HO2 straps

By combining HA/HI2/HO2 straps on the FDD main board with HDS strap on the FC-1 board, users can select the mode setting methods shown in Table 25. The factory-preset mode setting method is A.

For details of how to set the method of the SFD, refer to 10.7.

(Table 25) Strap setting when mode is selected

Mode setting method	Strap setting				Setting mode	FDD density mode setting signal level	Medium identification signal level	
	FC-1	FDD					HD IN *(PIN 2)	HD OUT
	HDS	HI2	HO2	HA		*(PIN 4)		*(PIN 2)
A	OFF	ON	OFF	OFF	1MB	LOW	LOW	—
					2.0MB	HIGH	HIGH	—
B	ON	OFF	ON	ON	1MB	—	—	LOW
					2.0MB	—	—	HIGH

Note: With PIN 2 and 4 (marked "*") of the FDD interface signal, the meaning and true level are defined by bytes 26 and 27 of PAGE code 5 of the MODE SELECT parameter.

(2) IR strap

With the IR strap, one of the following two front bezel indicator (LED) lighting conditions can be selected.

However, to prevent the lighting due to the polling operation of the DRIVE SELECT signal, the indicator does not light for 3.1ms immediately after the DRIVE SELECT signal is made true under any conditions.

(Table 26) Selecting the front bezel indicator lighting conditions

IR strap	Front bezel indicator (LED) lighting conditions
—	DRIVE SELECT
ON	DRIVE SELECT * FDD READY state

Note: Symbol of "—" indicates the state when the strap = OFF.

(3) FG strap

Connects the FDD frame to 0V DC. (For details, refer to 5.2)