

SERIES/1 SYSTEM
IBM INSTALLATION INSTRUCTION

AA100
P/N 1633743
PAGE 1 OF 48

ENG. CHANGE NO. 323200 327517 327517B
DATE OF CHANGE 23NOV81 08JAN82 12MAR82

WRITER: R. QUINN

CHECKER: F. KIRALY

APPROVER: B. STOFAN

INFORMATION FORMERLY UNDER PART NUMBER 8326725 IS CONTAINED IN THIS DOCUMENT (P/N 1633743) FROM E.C. 323200 ONWARD.

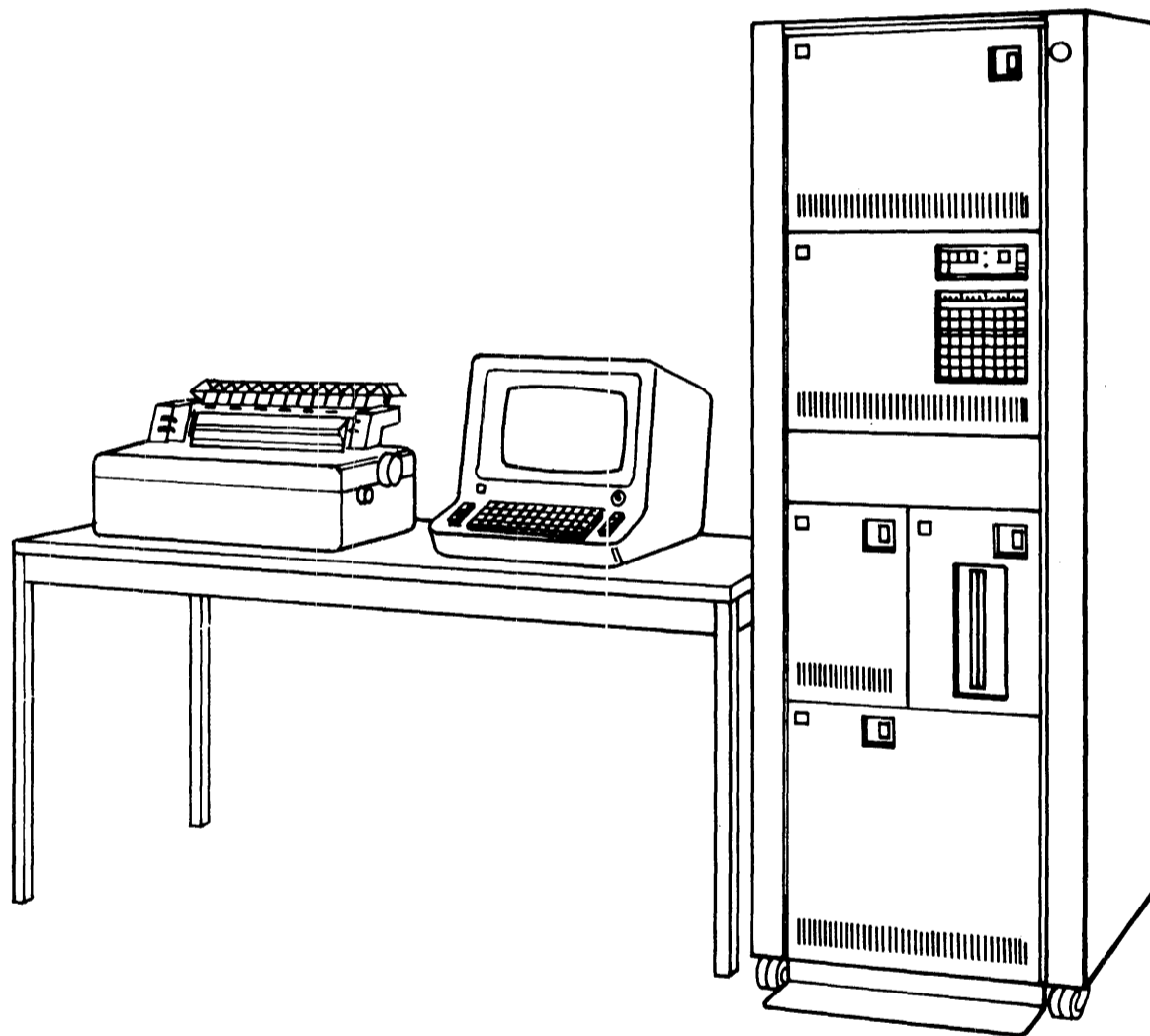

TABLE OF CONTENTS

	PAGE
PREFACE -----	3
SAFETY -----	4
SECTION 1.0 SERIES/1 INSTALLATION FACTORY CONFIGURED SYSTEM--	6
1.1 4997 ENCLOSURE -----	6
1.2 PROCESSORS AND EXPANSION UNIT (CONSOLE GATE COVERING I/O SLOTS) -----	6
1.3 PROCESSORS AND EXPANSION UNIT (CONSOLE GATE <u>NOT</u> COVERING I/O SLOTS) -----	6
1.4 4962 DISK STORAGE UNIT -----	7
1.5 4963 DISK SUBSYSTEM -----	9
1.6 4964 DISKETTE UNIT -----	10
1.7 4966 DISKETTE MAGAZINE UNIT -----	10
1.8 4969 TAPE SUBSYSTEM -----	11
1.9 4982 SENSOR I/O UNIT -----	11
1.10 4987 PROGRAMMABLE COMM. SUBSYSTEM & 4993 TERMINATION ENCLOSURE -----	11
SECTION 2.0 MULTIPLE RACK ASSEMBLY -----	12
2.1 1.8 METER RACK -----	12
2.2 1.0 METER RACK -----	12
2.3 RACK TO RACK CABLE INSTALLATION -----	13
SECTION 3.0 INSTALLING EXTERNAL/STANDALONE UNITS-----	15
3.1 STANDALONE PROCESSOR UNIT -----	15
3.2 CABLING EXTERNAL UNITS TO RACK -----	16
3.3 CUSTOMER CABLING RESPONSIBILITY -----	18
SECTION 4.0 SYSTEM POWER -----	19
4.1 PREPOWER CHECKS -----	20
4.2 SWITCH ON POWER -----	23
4.3 ADJUST OVERCURRENT SETTING -----	23
4.4 ADJUST +5 VOLT DC POTENTIOMETER -----	23
4.5 4952A MINIMUM LOAD SWITCH -----	23
4.6 MEASURE DC VOLTAGES -----	25
4.7 HALF WIDTH CARD FILES -----	25
SECTION 5.0 SYSTEM VERIFICATION -----	26
APPENDIX	
A. HARDWARE INSTALLATION RULES -----	28
B. NON I.B.M. RACK INSTALIATION -----	29
FULL WIDE UNIT IN RACK INSTALLATION -----	29
HALF WIDE UNIT IN RACK INSTALLATION -----	30
C. FEATURE INSTALLATION SUMMARY -----	31
7900 FEATURE CABLING -----	31
RACK ENCLOSURE BAY IDENTIFICATION -----	37
D. WORLD TRADE POWER CONSIDERATIONS -----	38
E. PROCESSOR/EXPANSION UNIT CABLING (FIELD INSTALLED UNITS)--	45

ENG. CHANGE NO. 323200 327517 327517B
DATE OF CHANGE 23NOV81 08JAN82 12MAR82

PREFACE

THIS MANUAL CONTAINS INFORMATION WHICH IS NECESSARY FOR THE INSTALLATION OF I.B.M. MACHINES OF THE SERIES/1 GROUP. AND PUBLICATIONS. THE SECTIONS AND THE STEPS WITHIN THE SECTIONS ARE ARRANGED SO THAT THE INSTALLER CAN PROCEED LOGICALLY THROUGH THE ENTIRE INSTALLATION SEQUENCE REGARDLESS OF THE CONFIGURATION INVOLVED.

IF A PROCEDURE IS NOT SUITABLE FOR YOUR CONFIGURATION, CONTINUE TO THE NEXT PROCEDURE. IF YOU HAVE MORE THAN ONE UNIT OF A GIVEN TYPE, REPEAT THE PROCEDURES UNTIL YOU HAVE COMPLETED THE INSTALLATION OF THOSE UNITS.

FOR PROPER PERFORMANCE OF THE IBM MACHINES, IT IS RECOMMENDED THAT THE OEM ENCLOSURE BE METALLIC AND MEET U.L. 478 (OR EQUIVALENT) MECHANICAL REQUIREMENTS WITH THE RECOMMENDED SYSTEM GROUNDING AND SHIELDING TECHNIQUES.

EACH UNIT THAT IS SPECIFICALLY DESIGNED TO BE SUPPORTED AND/OR ENCLOSED BY A SUITABLE RACK STRUCTURE SHOULD BE OF A TYPE WHICH MEETS THE E.I.A. STANDARD. THIS STRUCTURE MUST INCLUDE PROVISION FOR INTERNAL ROUTING OF ANY INTERCONNECTING CABLING BETWEEN TWO OR MORE UNITS. CONFIGURATIONS OF THESE MACHINES WHICH ARE NOT SO ENCLOSED MAY NOT PERFORM ACCORDING TO FUNCTIONAL SPECIFICATION AND MAY NOT COMPLY WITH LOCAL CODES. REQUIREMENTS FOR OEM RACK ENCLOSURE ARE LOCATED IN THE CUSTOMER SITE PREP. MANUAL (GA34-0050).

RACK MOUNTABLE UNITS (4962, 4963, 4964, 4966, 4969, 4982, 4987, 4993 AND THE 4999) ARE TO BE INSTALLED ACCORDING TO THE UNIT INSTALLATION INSTRUCTIONS ACCOMPANYING EACH UNIT. (IF NOT PREVIOUSLY IBM PLANT INSTALLED).

NON-RACK MOUNTED I/O UNITS ARE TO BE INSTALLED ACCORDING TO THE UNIT INSTALLATION INSTRUCTIONS ACCOMPANYING EACH UNIT. THE INSTALLER SHOULD READ THESE INSTALLATION INSTRUCTIONS BEFORE BEGINNING THE ACTUAL INSTALLATION.

CHECK WITH THE USER'S SITE PLANNER TO ENSURE THAT SITE PREPARATION (SERVICE OUTLETS, VOLTAGE, PHASE, ROTATION, GROUNDING, AND SIMILAR CONDITIONS) HAVE BEEN DONE AS NEEDED.

ENG. CHANGE NO. 323200 327517 327517B
DATE OF CHANGE 23NOV81 08JAN82 12MAR82

SAFETY

GENERAL

PERSONAL SAFETY CANNOT BE OVEREMPHASIZED. SERVICE PERSONNEL MUST NOT WORK ALONE WHEN PERFORMING ANY MAINTENANCE OR REPAIR WITH POWER ON. AT LEAST TWO PERSONS SHOULD BE PRESENT WHENEVER ANY WORK IS DONE ON A MACHINE WITH POWER ON. SERVICE PERSONNEL SHOULD WEAR SAFETY GLASSES DURING ANY MAINTENANCE REPAIR OPERATION

FIRE EXTINGUISHERS SHOULD BE AVAILABLE IN EACH ROOM WHERE THERE ARE SYSTEM COMPONENTS. EXTINGUISHERS SHOULD BE OF THE CO2 TYPE, WHICH ARE RECOMMENDED FOR ELECTRICAL FIRES.

REPLACE ANY SAFETY COVERS THAT HAVE BEEN REMOVED BEFORE GOING ON TO ANOTHER OPERATION. HAZARDOUS VOLTAGES ARE PRESENT IN THIS EQUIPMENT; FORGETFULNESS COULD BE FATAL. DON'T USE UNGROUNDED TOOLS OR TEST EQUIPMENT. THEY CAN KILL!

PERSONAL SAFETY

EXPOSURE TO ENVIRONMENTAL HAZARDS

THE INSTALLER SHOULD GIVE SPECIAL ATTENTION TO THE USER'S I/O LINES FOR THEY MAY CONTAIN VOLTAGES. THE SYSTEM CAN BE LINKED DIRECTLY TO THE USERS PROCESS, AND VOLTAGES CAN BE INTRODUCED INTO THE SYSTEM FROM A NUMBER OF SOURCES. WITH POWER REMOVED FROM THE SYSTEM, VOLTAGES CAN STILL BE PRESENT IN THE USERS TERMINATION AREA. ALL LINES ARE POTENTIALLY DANGEROUS AND SHOULD BE REGARDED AS LIVE CIRCUITS. WHEN ENTERING ANY PART OF THE PROCESS AREA, OBSERVE ALL SAFETY PRECAUTIONS AND REGULATIONS. CHECK THE FOLLOWING ITEMS WITH PRINCIPAL CUSTOMER PERSONNEL:

1. THE NEED FOR SAFETY GLASSES, HARD HATS, OR SPECIAL CLOTHING.
2. PARTICULAR ROUTE THAT MUST BE TAKEN TO AND FROM INSTALLATION. ESCORT REQUIRED?
3. SMOKING RESTRICTIONS.
4. RESTRICTIONS ON USE OF ELECTRICAL OR OTHER SPARK-PRODUCING TOOLS.
5. EXPOSURE TO HIGH VOLTAGES.
6. EXPOSURE TO HEAVY MACHINERY OR OTHER EQUIPMENT.
7. EXPOSURE TO SPLASHING ACIDS, MOLTEN METAL, HOT LIQUIDS, ETC.
8. EXPOSURE TO TOXIC GASES AND VAPORS.
9. WARNING ALARMS AND EMERGENCY EXITS.

MACHINE WARNING LABELS

HEED THE WARNING LABELS PLACED IN HAZARDOUS AREAS OF THE MACHINE. THEY ARE PLACED THERE FOR YOUR PROTECTION.

POWER SUPPLIES

BEFORE WORKING ON ANY POWER SUPPLY, REMOVE POWER FROM THE UNIT AND ALLOW AT LEAST ONE MINUTE FOR CAPACITORS TO DISCHARGE TO A SAFE VOLTAGE LEVEL.

POWER CORDS

CHECK POWER CORDS FOR SAFE CONDITION AND PROPER THIRD-WIRE GROUND CONNECTION. CHECK WITH A METER FROM GROUND ON THE PLUG TO FRAME AND INSURE THAT THERE IS A ZERO OHM READING. IF NOT, REFER TO THE MAPS.

LINE-POWERED EQUIPMENT

OSCILLOSCOPES AND OTHER LINE-POWERED EQUIPMENT MUST ALWAYS BE GROUNDED THROUGH THE THIRD-WIRE GROUNDING CONDUCTOR IN THE POWER CORD.

EQUIPMENT PRECAUTIONS

USERS INTERFACE

THE SYSTEM MAY BECOME (DEPENDING UPON PRODUCT MIX) AN INTEGRAL PART OF THE USERS OPERATION. DO NOT, UNDER ANY CIRCUMSTANCES, WORK ON ANY PART OF THE SYSTEM WITHOUT THE PRIOR KNOWLEDGE AND CONSENT OF THE PRINCIPAL USER.

PRODUCT HARDWARE

USE CAUTION WHEN WORKING AROUND HARDWARE. DO NOT LEAVE FRONT COVERS OFF WHEN POWER IS ON. INSURE THE TILT STABILIZER ON THE RACK IS FASTENED TO FRAME IN DOWN POSITION.

LOGIC COMPONENTS

ELECTRICAL OVERLOADS FOR PERIODS AS SHORT AS A FEW MICROSECONDS CAN SERIOUSLY DAMAGE COMPONENT

ENG. CHANGE NO. 323200 327517 327517B
DATE OF CHANGE 23NOV81 08JAN82 12MAR82

MODULES. CARE MUST BE EXERCISED WHEN GROUNDING SIGNAL LINES, BECAUSE APPLYING A VOLTAGE INSTEAD OF A GROUND OR GROUNDING THE OUTPUT OF DRIVERS, EMITTER FOLLOWERS, ETC., WILL DESTROY LOGIC MODULES.

I/O CARDS

USE CARE WHEN REMOVING AND INSERTING I/O CARDS. FINGERPRINTS, PENCIL MARKS, AND OTHER CONTAMINANTS DECREASE THE LEAKAGE RESISTANCE OF THESE CARDS. DO NOT USE CLEANING SOLVENTS OR CARD LUBRICANTS, AND DO NOT PERMIT THE PLASTIC COATING ON THE CARD TO BECOME DAMAGED. INSERTING OR REMOVING CARDS WHILE THE MACHINE IS POWERED ON MAY DAMAGE THE CARDS. DO NOT INSERT OR REMOVE LOGIC CARDS FROM MACHINE CIRCUITRY WHILE MACHINE POWER IS SWITCHED ON.

SECTION 1.0 SERIES/1 INSTALLATION FACTORY CONFIGURATION SYSTEM.

1.1 4997 ENCLOSURE

- () 1. OPEN REAR UNIT IF THIS ENCLOSURE IS NOT PART OF A MULTIPLE ENCLOSURE CONFIGURATION, INSTALL THE EMERGENCY PULL KNOB (1), FIGURE 1.1.1.0 AND THE ENCLOSURE STABILIZER. IF IT IS PART OF A MULTIPLE ENCLOSURE CONFIGURATION, DO NOT INSTALL THE KNOB OR STABILIZER UNTIL INSTRUCTED IN A LATER STEP.

FIGURE 1.1.0.0

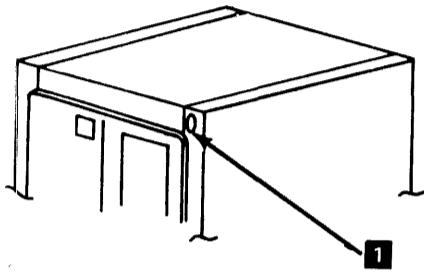

- () 2. REMOVE ALL TAPE HOLDING CABLES AT REAR OF UNIT.

1.2 PROCESSORS AND EXPANSION UNIT (CONSOLE GATE COVERING I/O SLOTS).

FIG. 1.2.1.0

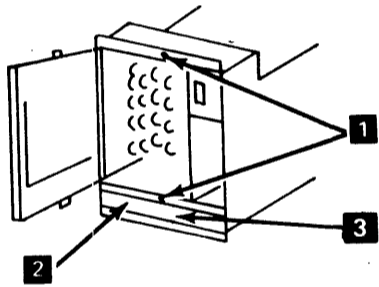

- () 1. REMOVE FRONT COVER BY PULLING STRAIGHT OUT FROM UNIT. OPEN CONSOLE FRAME BY LOOSENING TWO SCREWS (1).
- () 2. REMOVE PADS (2).
- (_ 3. CHECK ALL LOGIC CARDS AND CONNECTORS FOR CORRECT SEATING.
- () 4. CLOSE CONSOLE, TIGHTEN SCREWS.

1.3 PROCESSORS AND EXPANSION UNIT (CONSOLE GATE NOT COVERING I/O SLOTS)

FIG. 1.3.0.0

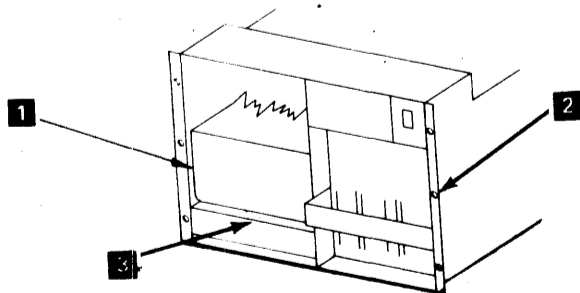

- () 1. REMOVE FRONT COVER BY PULLING STRAIGHT OUT FROM UNIT. REMOVE FOAM PAD (1).
- () 2. CHECK ALL LOGIC CARDS AND CONNECTORS FOR CORRECT SEATING.
- () 3. CLOSE FRONT.

1.4 4962 DISK STORAGE UNIT

- () 1. REMOVE FRONT COVER BY INSERTING SCREWDRIVER OR SIMILAR DEVICE IN OPENING (1), FIGURE 1.4.1.0 AND PULLING OUT AT TOP OF COVER.
- () 2. REMOVE UNIT MOUNTING SCREWS (2), FIGURE 1.4.2.0, SLIDE UNIT FORWARD UNTIL IT LOCKS IN PLACE.
- () 3. LOOSEN FOUR WASHER NUTS (3), FIGURE 1.4.3.0.
- () 4. LOOSEN SIX SCREWS HOLDING THE SIDE COVERS (4), FIGURE 1.4.3.0. REMOVE LEFT COVER, RIGHT FRONT COVER, AND RIGHT REAR COVER IN THAT ORDER.
- () 5. REMOVE ONE LOCKING BOLT (5), FIGURE 1.4.4.0.
- () 6. REMOVE PLASTIC SHIMS FROM 3 SHOCK MOUNTINGS (6), FIGURE 1.4.4.0.
- () 7. OPEN GATE (7), FIGURE 1.4.5.0, BY LOOSENING SCREW (8), FIGURE 1.4.5.0. CAREFULLY SEPARATE AND OPEN GATES OUT. NOTE: MODELS WITHOUT DISKETTE UNITS, ONLY THE LOWER GATE NEED BE OPENED BY LOOSENING SCREW (8), FIGURE 1.4.5.0.
- () 8. REMOVE FOAM BLOCKS (10), FIGURE 1.4.5.0, PROTECTING THE DISKETTE UNIT (MODELS 002, 02F ONLY). REMOVE FOAM BLOCK (11), FIGURE 1.4.5.0 AND TWO WOODEN BLOCKS (12), FIGURE 1.4.5.0.
- () 9. LOCATE THE ACTUATOR LOCKING ARM (13), FIGURE 1.4.6.0, UNLOCK THE ACTUATOR AS SHOWN.
- () 10. NEXT, LOCATE THE SPINDLE LOCK (14), FIGURE 1.4.6.0 MOVE TO THE UNLOCKED POSITION AS SHOWN. ENSURE THE SPINDLE LOCKING ARM'S LONG FINGER IS IN ITS CORRECT POSITION AS IT IS NOW THE SPINDLE GROUND.
- () 11. CHECK TO ENSURE DRIVE BELT (15), FIGURE 1.4.7.0, IS CORRECTLY LOCATED ON THE DISK DRIVE.
- () 12. CHECK ALL LOGIC CARDS AND CONNECTORS FOR CORRECT SEATING.
- () 13. CLOSE GATE (OR GATES) AND REINSTALL/TIGHTEN SCREWS.
- () 14. REMOVE CONTAINER HELD BY TAPE ON THE FOOT.
- () 15. REINSTALL THREE OUTSIDE COVERS IN REVERSE ORDER OF REMOVAL. ENSURE THE TABS (16), FIGURE 1.4.8.0 ARE TIGHT AGAINST THE FRAME BEFORE FASTENING SCREWS.
- () 16. RELEASE LOCKING BUTTONS. SLIDE UNIT BACK INTO RACK AND REINSTALL MOUNTING SCREWS.
- () 17. TO REINSTALL FRONT COVER, HOLD THE UNIT'S STABILIZER UP, PUT THE BOTTOM OF COVER IN POSITION FIRST AND PUSH IN AT TOP TO ENGAGE THE LATCH.
- () 18. DISKETTE UNIT IS INCLUDED IN MOD 2 AND 2F. REMOVE CARDBOARD INSERT FROM DISKETTE UNIT.
- () 19. REPEAT STEPS FOR MORE THAN ONE UNIT.

FIG. 1.4.1.0

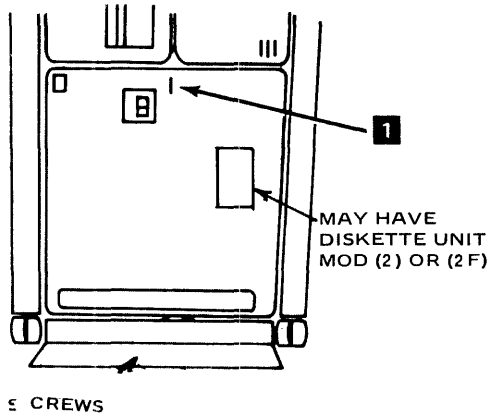

FIG. 1.4.2.0

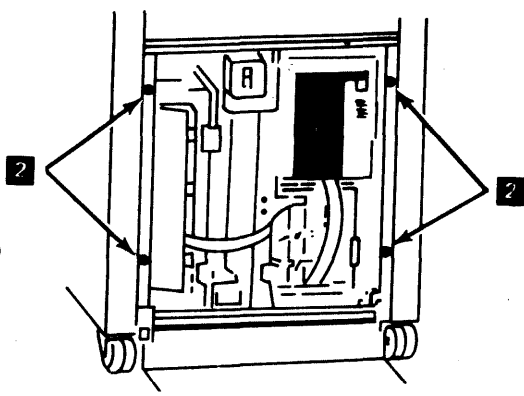
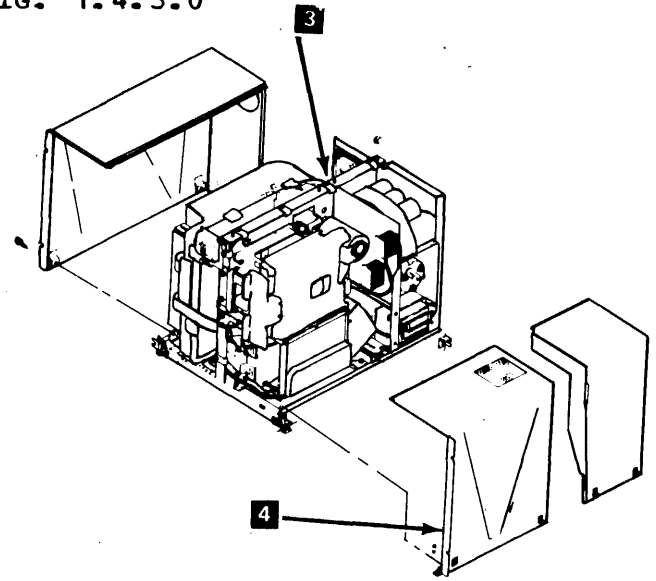

FIG. 1.4.3.0



1.4.4.0

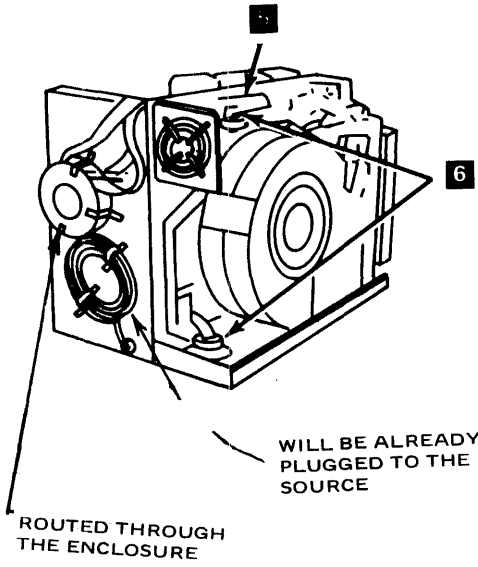

FIG. 1.4.5.0 THIS IS A SEPARATE GATE

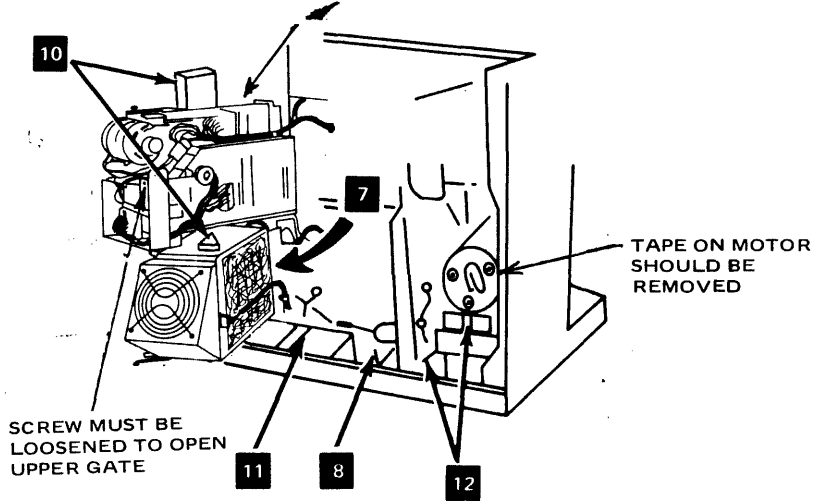
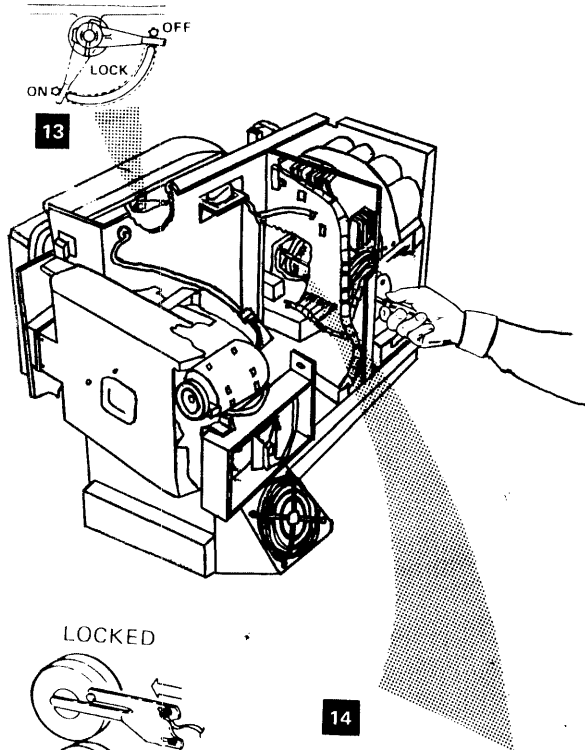

FIG. 1.4.6.0



1.4.7.0

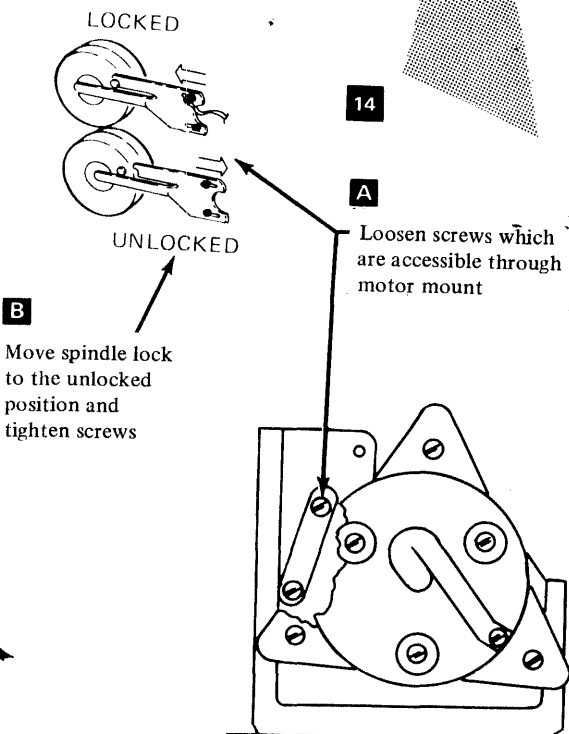
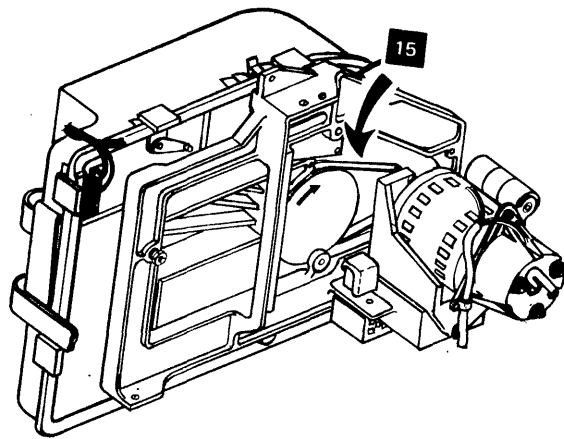
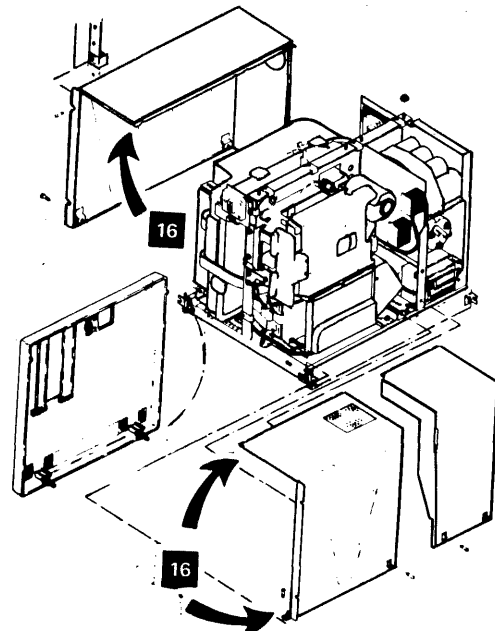

FIG. 1.4.8.0



ENG. CHANGE NO. 323200 327517 327517B
 DATE OF CHANGE 23NOV81 08JAN82 12MAR82

1.5 4963 DISK SUBSYSTEM

- () 1. REMOVE FRONT COVER AND SLIDE DISK INTO SERVICE POSITION.
- () 2. REMOVE TOP COVER BY REMOVING TWO REAR THUMB SCREWS AND TWO SIDE SCREWS. LOOSEN FRONT SCREW. RETAIN SCREWS FOR ASSEMBLY.
- () 3.
- () 4. LOCATE THE FILE LOCKOUT SCREW (7), FIGURE 1.5.4.0. REMOVE SCREW, WASHER AND SPACER AND STORE IN CHASSIS (8), FIGURE 1.5.4.0.
- () 5. OPEN FILE CARD GATE (10), FIGURE 1.5.5.0 FOR ACCESS TO ACTUATOR LOCK KNOB (11), FIGURE 1.5.5.0.
- () 6. LOCATE THE ACTUATOR ARM LOCK KNOB (9), FIGURE 1.5.5.0.
- () 7. UNLOCK THE ACTUATOR ARM, TURN THE ACTUATOR LOCK KNOB (11), FIGURE 1.5.5.0 COUNTER-CLOCKWISE THROUGH 120 DEGREES.
- () 8. CLOSE AND LOCK FILE CARD GATE (10), FIGURE 1.5.5.0.
- () 9. CHECK FILE DRIVE BELT FOR PROPER ALIGNMENT. ENGAGE DRIVE BELT TENSIONER.
- () 10. CHECK FOR DAMAGED PARTS.
- () 11. INSTALL TOP COVER REMOVED IN STEP 2.
- () 12. INSTALL THE FRONT 4963 COVER BY POSITIONING THE TWO COVER STUDS IN THE BASE. PUSH THE COVER IN AT THE TOP AND BOTTOM UNTIL CATCHES ARE ENGAGED.
- () 13. REPEAT STEPS FOR MORE THAN ONE UNIT.

FIG. 1.5.1.0

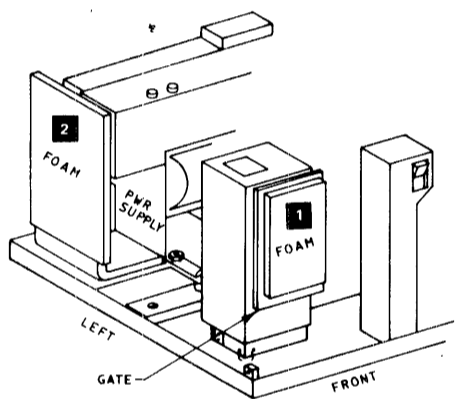

1.5.2.0

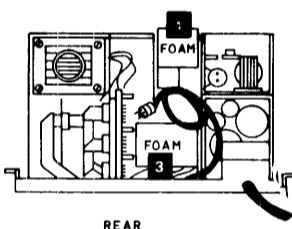

1.5.3.0

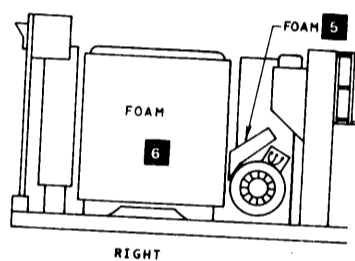
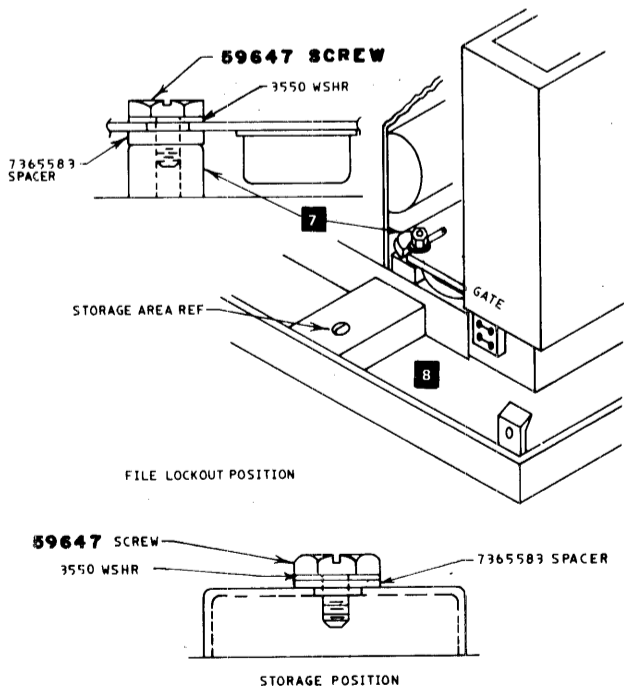
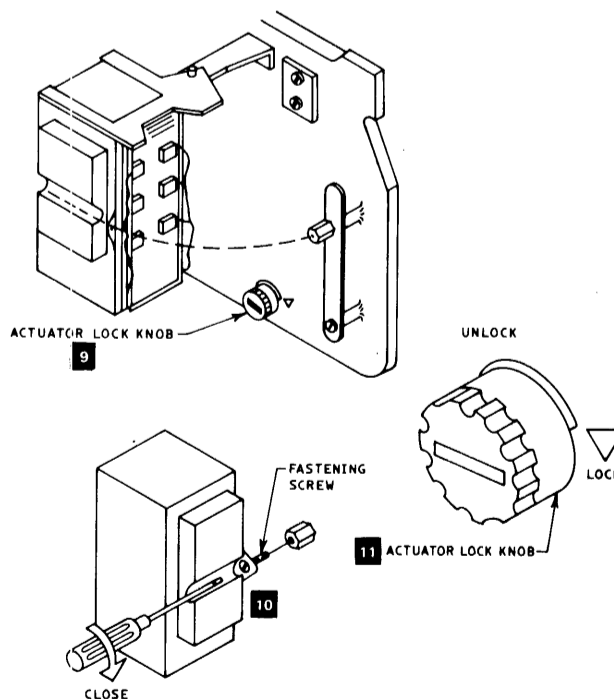

FIG. 1.5.4.0



1.5.5.0



ENG. CHANGE NO. 323200 327517 327517B
DATE OF CHANGE 23NOV81 08JAN82 12MAR82

1.6 4964 DISKETTE UNIT

- () 1. REMOVE PACKING MATERIALS INCLUDING PAPER (4), FIGURE 1.6.1.0 INSIDE DISKETTE UNIT.
 - () 2. OPEN DISKETTE. REMOVE FRONT COVER BY PULLING OUT AT TOP.
 - () 3. REMOVE RACK MOUNTING SCREWS (1), FIGURE 1.6.1.0 AND SLIDE UNIT FORWARD UNTIL YOU CAN REMOVE THE CABLES.
 - () 4. DISCONNECT SIGNAL CABLE ATTACHED AT TOP UNIT, SLIDE UNIT OUT FAR ENOUGH TO REMOVE TOP SHIELD.
- CAUTION -- DO NOT PULL THE UNIT ALL THE WAY OUT OF THE RACK; IT WILL FALL TO THE FLOOR.
- () 5. REMOVE TOP SHIELD. REMOVE FOAM BLOCK (2), FIGURE 1.6.1.0. REMOVE WOOD INSERT (5), FIGURE 1.6.1.0.
 - () 6. REINSTALL TOP SHIELD, SLIDE UNIT BACK, CONNECT SIGNAL CABLE, AND SLIDE UNIT INTO RACK. REINSTALL MOUNTING SCREWS.
 - () 7. REMOVE THE SHIP GROUP (3), FIGURE 1.6.1.0.
 - () 8. TO REINSTALL FRONT COVER, ENSURE THAT THE DISKETTE MECHANISM IS OPEN, PUT THE BOTTOM IN POSITION FIRST, AND PUSH IN AT THE TOP TO ENGAGE THE COVER.
 - () 9. REPEAT STEPS FOR MORE THAN ONE UNIT.

FIG. 1.6.1.0

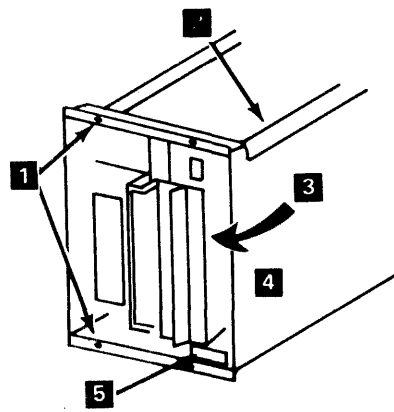

1.7 4966 DISKETTE MAGAZINE UNIT

- () 1. OPEN DISKETTE UNIT. REMOVE FRONT COVER BY PULLING OUT AT TOP. REMOVE MACHINE SLIDE COVER. LOCATE FOAM SHIPPING BLOCK (1), FIGURE 1.7.1.0 AND REMOVE FROM TOP OF MACHINE CASTING. (SHIPPING BLOCKS MAY NOT BE PRESENT-DEPENDING UPON METHOD OF SHIPMENT).
- () 2. REMOVE CARDBOARD INSERT FROM DISKETTE SLOT (2), FIGURE 1.7.2.0. REMOVE FOAM BLOCKS (3), FIGURE 1.7.2.0 FROM MAGAZINE TRAY. CHECK TO MAKE SURE THERE IS NO PHYSICAL DAMAGE TO THE UNIT. (SHIPPING BLOCKS MAY NOT BE PRESENT-DEPENDING UPON METHOD OF SHIPMENT).
- () 3. CHECK THE LINE CORD AND MAKE SURE IT IS NOT PLUGGED IN. THEN, CHECK THE DRIVE MOTOR FOR FREE OPERATION BY MANUALLY ROTATING IT.
- () 4. SLIDE MACHINE ALL THE WAY OUT OF FRAME.
- () 5. REMOVE TWO SHIPPING SCREWS FROM PICKER/CAM CASTING (4), FIGURE 1.7.3.0.
- () 6. REMOVE NUT AND BRACKET (5), FIGURE 1.7.4.0.
- () 7. REMOVE TWO SCREWS HOLDING THE DEVICE TO FRONT AND REAR SHOCK MOUNTS (6), FIGURE 1.7.4.0.
- () 8. PRY UP THE DEVICE AND REMOVE THE SCREW HOLDING THE SHIPPING BRACKET.
- () 9. REINSTALL THE TWO SCREWS INTO SHOCK MOUNTS (6), FIGURE 1.7.4.0.
- () 10. REPLACE SIDE COVERS AND FRONT COVERS.
- () 11. REPEAT STEPS FOR MORE THAN ONE UNIT.

ENG. CHANGE NO. 323200 327517 327517B
DATE OF CHANGE 23NOV81 08JAN82 12MAR82

FIG. 1.7.1.0

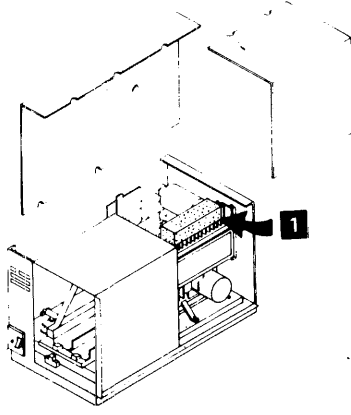
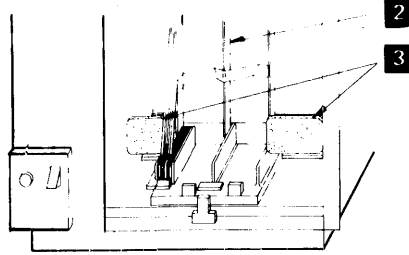

FIG. 1.7.2.0



1.7.3.0

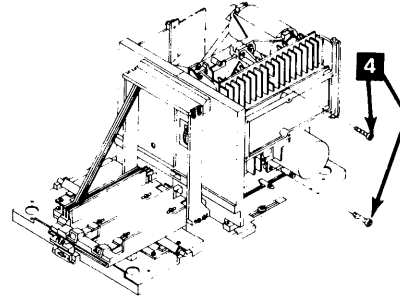
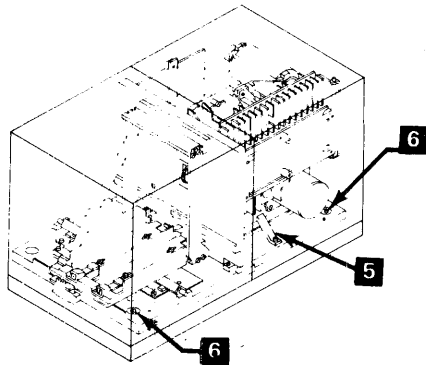

FIG. 1.7.4.0



1.8 4969 TAPE SUBSYSTEM

- () 1. OPEN FRONT DOOR.
- () 2. INSPECT UNIT FOR SHIPPING DAMAGE. (THERE IS NO INTERNAL PACKING MATERIAL TO BE REMOVED).
- () 3. CLOSE FRONT DOOR.

1.9 4982 SENSOR INPUT/OUTPUT UNIT

- () 1. REMOVE TAPE HOLDING REAR GATE (1), FIGURE 1.9.1.0.
- () 2. INSPECT UNIT FOR SHIPPING DAMAGE. (THERE IS NO INTERNAL PACKING MATERIAL TO BE REMOVED).

FIG. 1.9.1.0

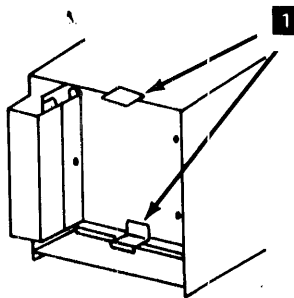

1.10 4987 PROGRAMMABLE COMMUNICATIONS SUBSYSTEM AND 4993 TERMINATION ENCLOSURE

- () 1. REMOVE FRONT COVER BY PULLING STRAIGHT OUT FROM UNIT.
- () 2. INSPECT UNIT FOR SHIPPING DAMAGE. (THERE IS NO INTERNAL PACKING MATERIAL TO BE REMOVED).
- () 3. REPLACE FRONT COVER.

SECTION 2.0 MULTIPLE RACK ASSEMBLY

2.1 MULTIPLE 1.8 METER RACK ENCLOSURE INSTALLATION

MULTIPLE (MORE THAN ONE) RACK CONFIGURATION WILL BE SHIPPED AS SINGLE ENCLOSURES BECAUSE OF THE FIXED WHEELS AT THE FRONT. ALL ENCLOSURES WITH A SPECIFY CODE #9197 (PRIMARY RACK ENCLOSURE) WILL BE SHIPPED WITH A FULL SET OF COVERS. ALL ENCLOSURES WITH A SPECIFY CODE #9198 (SUBSEQUENT RACK ENCLOSURE) WILL BE SHIPPED WITH NO SIDE COVERS, BUT WITH THE NEEDED ATTACHMENT HARDWARE INCLUDED. THESE ENCLOSURES ARE "ADD ON" ENCLOSURES.

- () 1. INSTALLATION IN THE CUSTOMER AREA WILL START WITH REMOVAL OF THE SIDE COVER OF THE PRIMARY RACK ENCLOSURE ON THE SIDE THAT WILL BECOME THE INTERFACE FOR THE MULTIPLE RACK CONFIGURATION. THE REMOVED COVER WILL BE REINSTALLED ON THE FAR SIDE OF THE LAST ADD ON ENCLOSURE.
- () 2. LIFT THE RACK STABILIZERS AND MOVE THE ENCLOSURES TO BE ATTACHED TOGETHER AND ALIGN WITH THE REAR LEVELING PADS, THEN CONNECT AT THE TOP (1), FIGURE 2.1.1.0 AND BOTTOM (2), FIGURE 2.1.1.0 WITH THE BOLTS, WASHERS, AND NUTS SUPPLIED.
- () 3. INSTALL FOUR SPRINGS (7), FIGURE 2.1.2.0 (P/N 4410811) AT THE FRONT AND REAR WITH HARDWARE SUPPLIED.
- () 4. INSTALL THE "L" SHAPED FRONT AND REAR FILLER COVERS; THE FRONT COVER (4), FIGURE 2.1.2.0 IS P/N 4410808 WHILE THE REAR COVER (6), FIGURE 2.1.2.0 IS P/N 4410810. THESE PARTS CAN BE IDENTIFIED EASILY BECAUSE THE FRONT FILLER COVER HAS A HOLE FOR THE EMERGENCY PULL KNOB (3), FIGURE 2.1.2.0. BOTH COVERS ARE INSTALLED BY HOLDING AGAINST THE VERTICAL SURFACE OF THE SPRING, PRESSING DOWNWARD UNTIL SEATED, AND FASTENING WITH TWO SCREWS AT THE TOP.
- () 5. THE TOP FILLER COVER, P/N 4410809, (5), FIGURE 2.1.2.0 IS INSTALLED WITH TWO SCREWS SUPPLIED.
- () 6. EACH RACK OF A MULTIPLE RACK SYSTEM HAS A PRIMARY POWER LINK CABLE. UNITS MUST BE POWERED FROM THE POWER DISTRIBUTION PANEL IN THE RACK IN WHICH THEY ARE INSTALLED. NO PRIMARY POWER CABLES MAY GO ACROSS A TWO RACK INTERFACE. TO DO SO WOULD CAUSE A SAFETY HAZARD.
- () 7. EACH RACK IN A MULTIPLE RACK SYSTEM HAS AN EMERGENCY PULL KNOB (INSTANT POWER OFF) ON THE FRONT SIDE OF THE ENCLOSURE. THE EMERGENCY PULL KNOB CONTROLS THE PRIMARY POWER ONLY FOR THAT RACK. INSTALL THE KNOBS.
- () 8. AFTER LOCATING EACH ENCLOSURE IN ITS FINAL POSITION, YOU MUST PUSH THE ENCLOSURE STABILIZER DOWN AND TO THE REAR, AND FASTEN ON BOTH ENDS.

FIG. 2.1.1.0

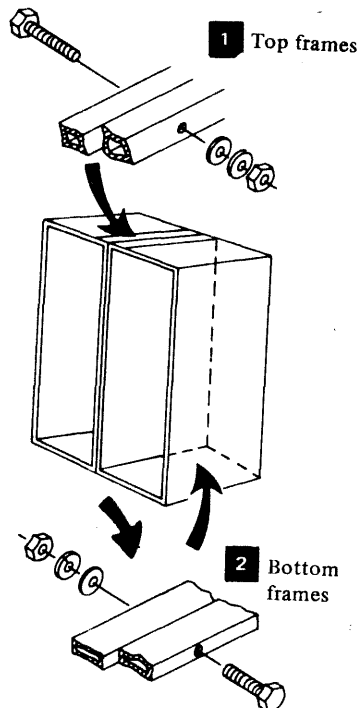
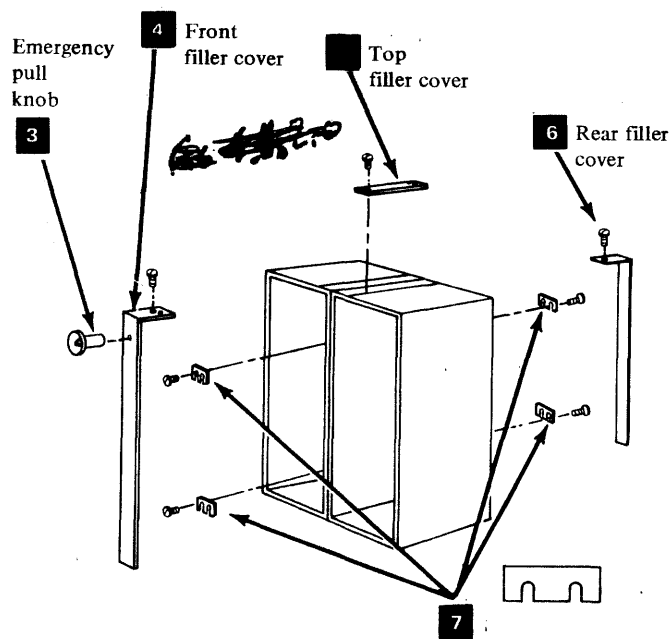

FIG. 2.1.2.0



2.2 MULTIPLE 1 METER RACK ENCLOSURE INSTALLATION

MULTIPLE (MORE THAN ONE) RACK CONFIGURATIONS WILL BE SHIPPED AS SINGLE ENCLOSURES BECAUSE OF THE FIXED WHEELS AT THE FRONT. ALL ENCLOSURES WITH A SPECIFY CODE #9197 (PRIMARY RACK ENCLOSURE) WILL BE SHIPPED WITH A FULL SET OF COVERS. ALL ENCLOSURES WITH A SPECIFIC CODE #9178 (SUBSEQUENT RACK ENCLOSURE) WILL BE SHIPPED WITH NO SIDE COVERS, BUT WITH THE NEEDED ATTACHMENT HARDWARE INCLUDED. THESE ENCLOSURES ARE "ADD ON" ENCLOSURES.

- () 1. INSTALLATION IN THE CUSTOMER AREA WILL START WITH REMOVAL OF THE SIDE COVER OF THE FIRST ENCLOSURE ON THE SIDE THAT WILL BECOME THE INTERFACE FOR THE MULTIPLE RACK CONFIGURATION. REMOVE THE EMERGENCY PULL KNOB (3), FIGURE 2.2.2.0 BEFORE ATTEMPTING TO REMOVE THE RIGHT SIDE COVER. THE REMOVED COVER WILL BE REINSTALLED ON THE FAR SIDE OF THE LAST ADD ON ENCLOSURE.

ENG. CHANGE NO. 323200 327517 327517B
 DATE OF CHANGE 23NOV81 08JAN82 12MAR82

- () 2. MOVE THE ENCLOSURES TO BE ATTACHED TOGETHER AND ALIGN WITH THE REAR LEVELING PADS, THEN CONNECT AT THE TOP (1), FIGURE 2.2.1.0 AND BOTTOM (2), FIGURE 2.2.1.0 WITH THE BOLTS, WASHERS, AND SCREWS SUPPLIED.
- () 3. INSTALL THE COUPLING (7), FIGURE 2.2.2.0 P/N 4410821 AT THE LOWER FRONT WITH HARDWARE SUPPLIED.
- () 4. MACHINE TYPES INSTALLED IN THE UPPER POSITION OF EITHER ENCLOSURE MUST BE PULLED OUT TO GIVE ACCESS TO THE TWO SCREWS (4), FIGURE 2.2.2.0 AT THE TOP OF THE ENCLOSURE THAT HOLDS THE FRONT FILTER COVER (6), FIGURE 2.2.2.0 P/N 4410820. THE FRONT COVER IS INSTALLED BY PLACING THE BOTTOM END IN THE COUPLING THEN PUSHING THE TOP IN WHILE PRESSING DOWNWARD AND FASTENING WITH THE SCREWS SUPPLIED.
- () 5. THE REAR FILLER COVER (5), FIGURE 2.2.2.0 P/N 4410820 IS HELD IN PLACE AND FASTENED WITH FOUR SCREWS SUPPLIED.

NOTE: COMPLETE THE ASSEMBLY OF MULTIPLE RACKS BEFORE INSTALLING EXTERNAL CABLES.

- () 6. EACH RACK OF A MULTIPLE RACK SYSTEM HAS A PRIMARY POWER LINE CABLE. UNITS MUST BE POWERED FROM THE POWER DISTRIBUTION PANEL IN THE RACK IN WHICH THEY ARE INSTALLED. NO PRIMARY POWER CABLES MAY GO ACROSS A TWO-RACK INTERFACE. TO DO SO WOULD CAUSE A SAFETY HAZARD.
- () 7. EACH RACK IN A MULTIPLE RACK SYSTEM HAS AN EMERGENCY PULL KNOB (INSTANT POWER OFF) ON THE FRONT SIDE OF THE ENCLOSURE. THE EMERGENCY PULL KNOB CONTROLS THE PRIMARY POWER ONLY FOR THAT RACK. INSTALL THE KNOBS.
- () 8. AFTER LOCATING EACH ENCLOSURE IN ITS FINAL POSITION, YOU MUST PUSH THE ENCLOSURE STABILIZER DOWN AND TO THE REAR, AND FASTENED ON BOTH ENDS.

FIG. 2.2.1.0

FIG. 2.2.2.0

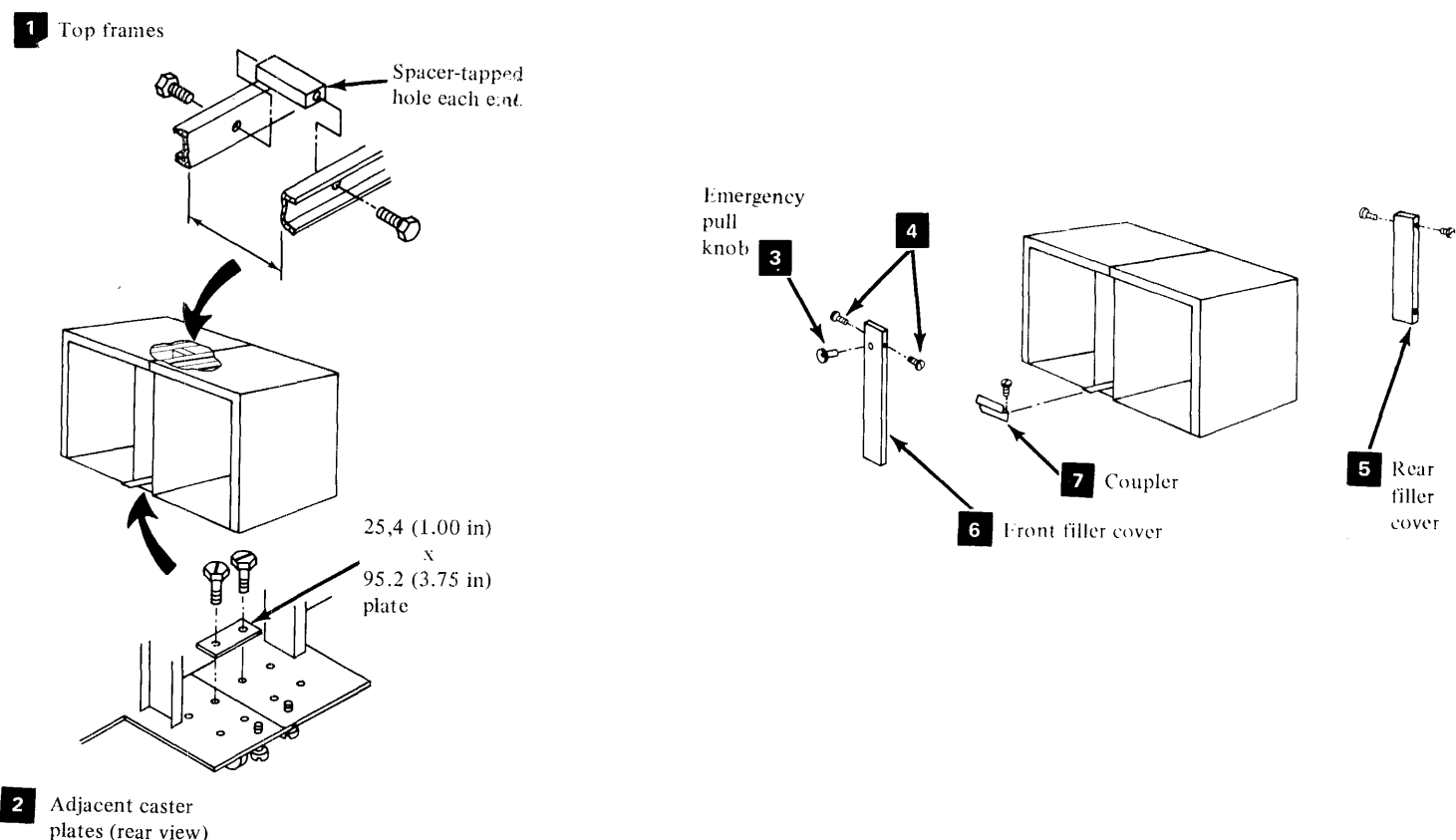

2.3 RACK TO RACK CABLE INSTALLATION (MULTIPLE RACK ENCLOSURES)

AFTER TWO OR MORE RACKS HAVE BEEN CONNECTED TOGETHER, SOME CABLES FROM I/O UNITS IN ONE ENCLOSURE MUST BE CONNECTED TO ATTACHMENT CARDS IN ANOTHER ENCLOSURE. SIGNAL CABLES BETWEEN ENCLOSURES MAY BE NORMAL INTERNAL SYSTEM CABLES. I/O CHANNEL SIGNAL CABLES TO AND FROM AN EXPANSION UNIT MAY GO BETWEEN RACKS THAT ARE NEXT TO ONE ANOTHER.

- () 1. DETERMINE THE LOCATION OF THE ATTACHMENT CARD BY REVIEWING THE CARD PLUG CHARTS (PACKED WITH THE DIAGNOSTIC DISKETTES) FOR THE PROCESSOR AND/OR I/O EXPANSION UNITS THAT ARE IN YOUR SYSTEM.
- () 2. REMOVE THE SCREWS THAT HOLD THE AFFECTED CARD FILE TO THE RACK.
- () 3. PULL THE UNIT OUT OF THE RACK APPROXIMATELY 150 MILLIMETERS (6 INCHES). IF CABLES PREVENT THIS MOVEMENT, DISCONNECT THEM.

WARNING: BE CAREFUL TO PREVENT DAMAGE TO CONNECTING CABLES.

- () 4. REMOVE THE CABLE CLAMP BRACKET (7), FIGURE 2.3.1.0.

ENG. CHANGE NO. 323200 327517 327517B
DATE OF CHANGE 23NOV81 08JAN82 12MAR82

- () 5. ROUTE THE CABLES (4), FIGURE 2.3.1.0 (FLAT OR CIRCULAR) FROM THE MACHINE REAR TO FRONT.
- () 6. ROUTE THE CABLES INTO THE CARD FILE THROUGH THE LARGE OPENING (3), FIGURE 2.3.1.0 ON TOP OF THE CARD FILE. INSERT CONNECTORS (6), FIGURE 2.3.1.0 ON THE CORRECT CARD.

IF I/O UNITS OR DEVICES WHICH ARE INSTALLED OUTSIDE THE RACKS ARE TO CONNECT TO ATTACHMENT CARDS IN THIS CARD FILE, DO NOT PERFORM STEPS 7, 8, 9 AND 10. CHECK THEM OFF AND GO TO STEP 11.
- () 7. INSTALL AND TIGHTEN THE CABLE CLAMP BRACKET (7), FIGURE 2.3.1.0.
- () 8. GROUP CABLES TOGETHER AND INSERT CABLE CLAMPS (2) (5), FIGURE 2.3.1.0 P/N 1634983 INTO THE CARD FILE TO HOLD THE CABLES.
- () 9. PUSH THE CARD FILE INTO THE RACK AND FASTEN WITH EIGHT #10-32 SCREWS.
- () 10. GROUP CABLES AT THE REAR OF THE CARD FILE AND INSERT THE REAR CABLE CLAMP (2), FIGURE 2.3.1.0.
- () 11. USE CABLE TIES TO HOLD EACH CABLE TO VERTICAL BARS OF THE RACKS. IF THE UNITS ARE INSTALLED HORIZONTALLY NEXT TO ONE ANOTHER IN A MULTIPLE RACK CONFIGURATION, CABLES ENTER AND LEAVE THE CARD FILE THE SAME AS IF THE UNITS WERE VERTICAL TO ONE ANOTHER. TYPICAL I/O CONFIGURATIONS ARE SHOWN IN FIGURE 2.3.1.0.

FIGURE 2.3.1.0

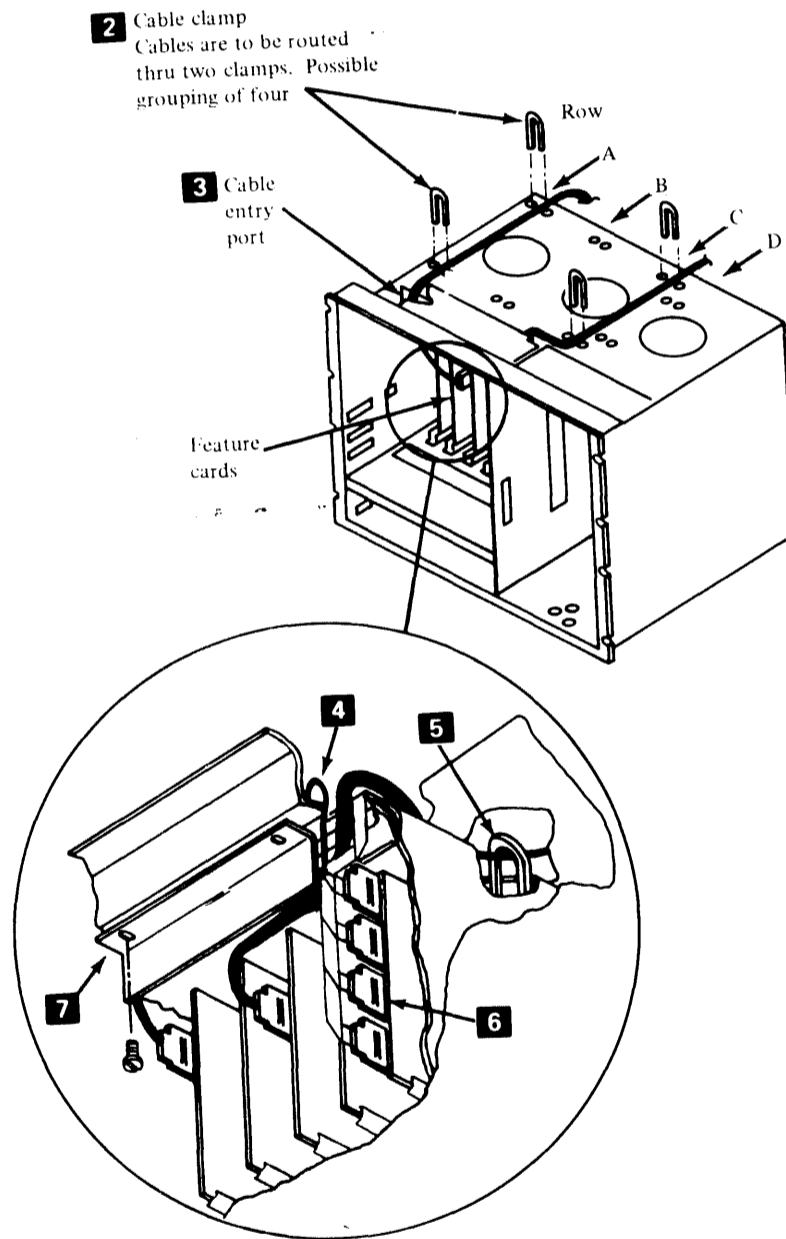

9 Processor to I/O Expansion unit cabling

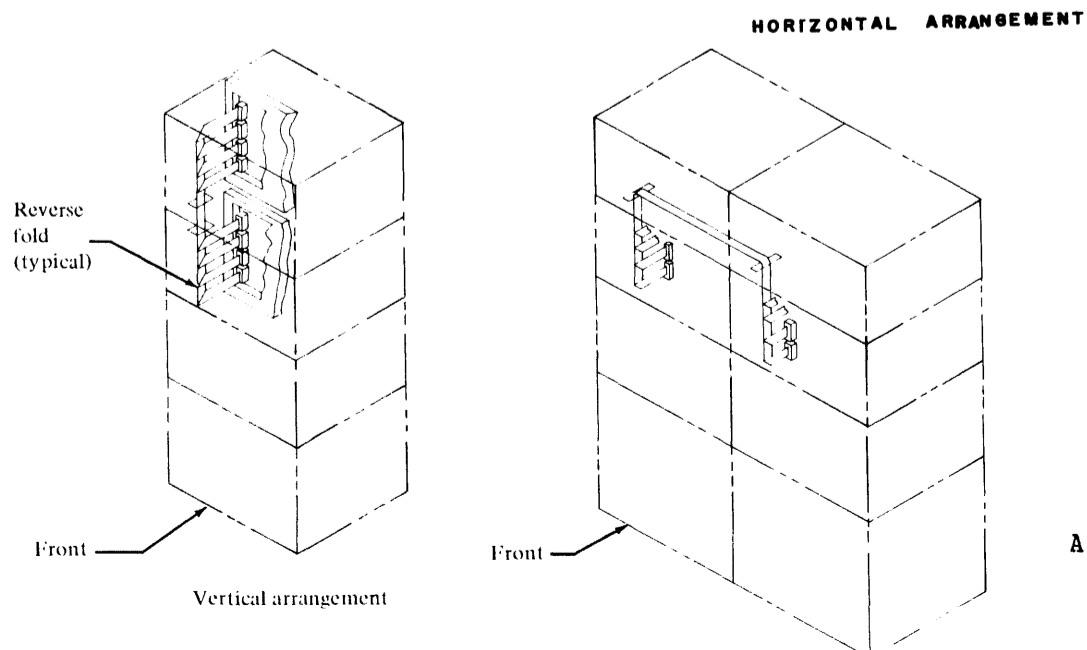

ENG. CHANGE NO. 323200 327517 327517B
DATE OF CHANGE 23NOV81 08JAN82 12MAR82

SECTION 3.0 INSTALLING EXTERNAL/STAND ALONE UNITS

REFER TO INDIVIDUAL UNIT INSTALLATION INSTRUCTIONS (SHIPPED WITH EACH UNIT).

3.1 STAND ALONE PROCESSOR UNIT INSTALLATION.

- A) REMOVE THE FRONT AND REAR DECORATIVE COVERS.
 - B) THE DISKETTE UNIT IN THE RIGHTMOST POSITION MAY HAVE TO BE PULLED OUT TO THE SERVICE POSITION IN ORDER TO FACILITATE THE REMOVAL OF THE TOP COVER.
 - C) REMOVE THE SCREWS WHICH FASTEN THE OPERATORS CONSOLE TO THE CHASSIS. SWING THE GATE OPEN.
 - D) REMOVE THE 4 COVER MOUNTING SCREWS (SEE FIGURE 3.1) AND LIFT OFF THE TOP COVER.
 - E) ROUTE THE CABLES FROM THE MACHINE REAR TO THE FRONT OF THE PROCESSOR VIA THE OPENING ON TOP OF THE UNIT. INSERT CONNECTORS ONTO THE APPROPRIATE CARD AND TIGHTEN CABLE CLAMP BRACKET.
 - F) GROUP CABLES TOGETHER AND INSERT CABLE CLAMP P/N 1634983 INTO THE TOP OF THE UNIT TO RETAIN THE CABLES.
 - G) CLAMP EACH CABLE TO THE MOUNTING STRIP IN THE REAR OF THE RACK AS SHOWN IN FIGURE 3.1. USE ANY AVAILABLE HCIE.
 - H) ATTACH THE CABLE GROUND SHIELD WIRE TO THE GROUND BUS LOCATED ON TOP OF THE PROCESSOR. USE THE SCREW AND LOCKWASHER LOCATED THERE. SEE FIGURE 3.1.
- NOTE: IF A GOOD ELECTRICAL GROUND CAN BE MADE BETWEEN THE CABLE SHIELD AND CLAMP IN STEP G, THIS STEP MAY BE OMITTED.
- I) CLOSE THE GATE AND REPLACE THE TOP COVER. SNAP ON THE DECORATIVE COVERS.
 - J) FOR REMOVAL OF CABLES, PERFORM THE ABOVE STEPS IN REVERSE ORDER.

FIGURE 3.1

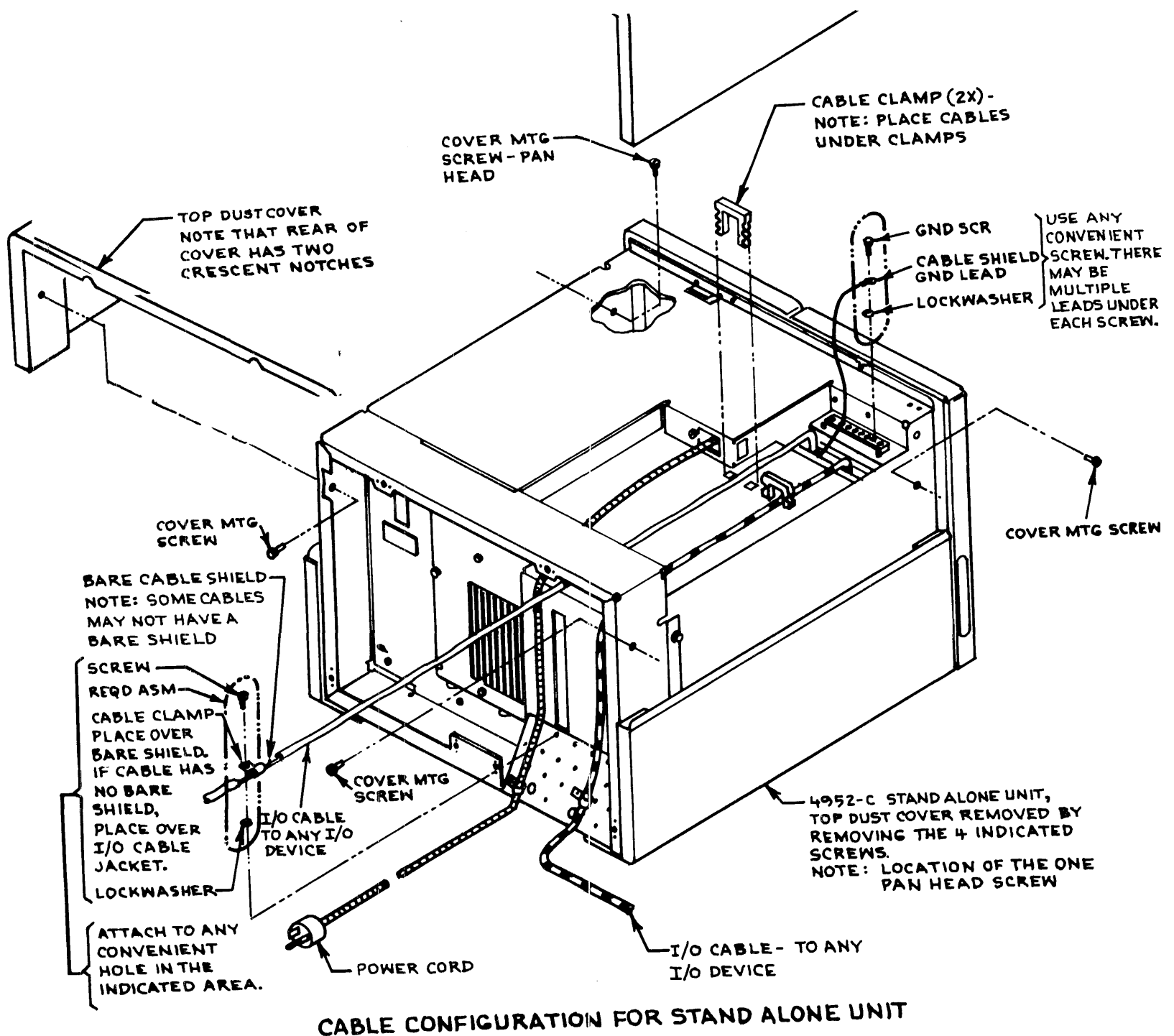

ENG. CHANGE NO. 323200 327517 327517B
DATE OF CHANGE 23NOV81 08JAN82 12MAR82

3.2 CABLING EXTERNAL UNITS TO RACK

EXTERNAL I/O UNITS ATTACH TO ATTACHMENT CARDS IN THE PROCESSOR AND/OR I/O EXPANSION UNITS THROUGH CABLES SUPPLIED WITH THE UNITS. THE FOLLOWING PROCEDURE MUST BE FOLLOWED FOR EACH UNIT THAT IS CONNECTED IN THIS WAY.

- () 1. DETERMINE THE LOCATION OF THE ATTACHMENT CARD BY REVIEWING THE CARD PLUG CHARTS (PACKED WITH THE DIAGNOSTIC DISKETTES) FOR THE PROCESSOR AND/OR I/O EXPANSION UNITS THAT ARE IN YOUR SYSTEM.
- () 2. REMOVE THE SCREWS THAT HOLD THE AFFECTED CARD FILE TO THE RACK.
- () 3. PULL THE UNIT OUT OF THE RACK APPROXIMATELY 150 MILLIMETERS (6 INCHES).
WARNING: BE CAREFUL TO PREVENT DAMAGE TO CONNECTING CABLES.
- () 4. REMOVE THE CABLE CLAMPS (2), (5), FIGURE 3.2.1.0 AND CABLE CLAMP BRACKET (7), FIGURE 3.2.1.0.
- () 5. ROUTE THE CABLES (4), FIGURE 3.2.1.0 (FLAT OR CIRCULAR) FROM THE MACHINE REAR TO FRONT. CUSTOMER SIGNAL CABLES SHOULD ENTER THE SYSTEM IN THAT RACK IN WHICH THE CABLE WILL BE TERMINATED. RACKS ARE TO BE ASSEMBLED TOGETHER BEFORE CABLES ARE ROUTED INTO THE RACK ENCLOSURE.
- () 6. ROUTE THE CABLES INTO THE CARD FILE THROUGH THE LARGE OPENING (3), FIGURE 3.2.1.0 ON TOP OF THE CARD FILE. INSERT CONNECTORS (6), FIGURE 3.2.1.0 ON THE CORRECT CARD.
- () 7. AFTER ALL OF THE EXTERNAL UNIT CABLES HAVE BEEN CONNECTED TO THEIR ATTACHMENT CARDS, INSTALL AND TIGHTEN THE CABLE CLAMP BRACKET (7), FIGURE 3.2.1.0.
- () 8. (NOTE: IF A GOOD ELECTRICAL GROUND CAN BE MADE IN STEP 12, THIS STEP CAN BE OMITTED). CONNECT ALL OF THE GROUND WIRES TO THE BUS BAR (8), FIGURE 3.2.1.0 ON TOP OF THE CARD FILE. ENSURE A GOOD ELECTRICAL GROUND BY USING THE LOCKWASHERS SUPPLIED.
- () 9. GROUP CABLES TOGETHER AND INSERT CABLE CLAMP (5), FIGURE 3.2.1.0 P/N 1634983 INTO THE CARD FILE TO HOLD THE CABLES.
- () 10. PUSH THE CARD FILE INTO THE RACK AND FASTEN WITH EIGHT BLACK #10-32 SCREWS.
- () 11. GROUP CABLES AT THE REAR OF THE CARD FILE AND INSERT THE REAR CABLE CLAMP (2), FIGURE 3.2.1.0.
- () 12. USE CLAMPS TO HOLD EACH EXTERNAL CABLE (9), FIGURE 3.2.2.0 TO THE VERTICAL MOUNTING STRIP (10), FIGURE 3.2.2.0 IN THE REAR OF THE RACK ON THE SIDE AWAY FROM THE POWER CABLE. DO NOT USE THE TOP HOLE. ONLY USE EVERY OTHER HOLE.

NOTE: NOT ALL CABLES HAVE A SHIELD SHOWN AS SHOWN IN (9). THE CLAMP WILL GO AROUND THE INSULATION ON THOSE CABLES.
- () 13. ROUTE THE CABLES OUT THROUGH THE CABLE ENTRY (11), FIGURE 3.2.2.0.

ENG. CHANGE NO. 323200 327517 327517B
DATE OF CHANGE 23NOV81 08JAN82 12MAR82

FIG. 3.2.1.0

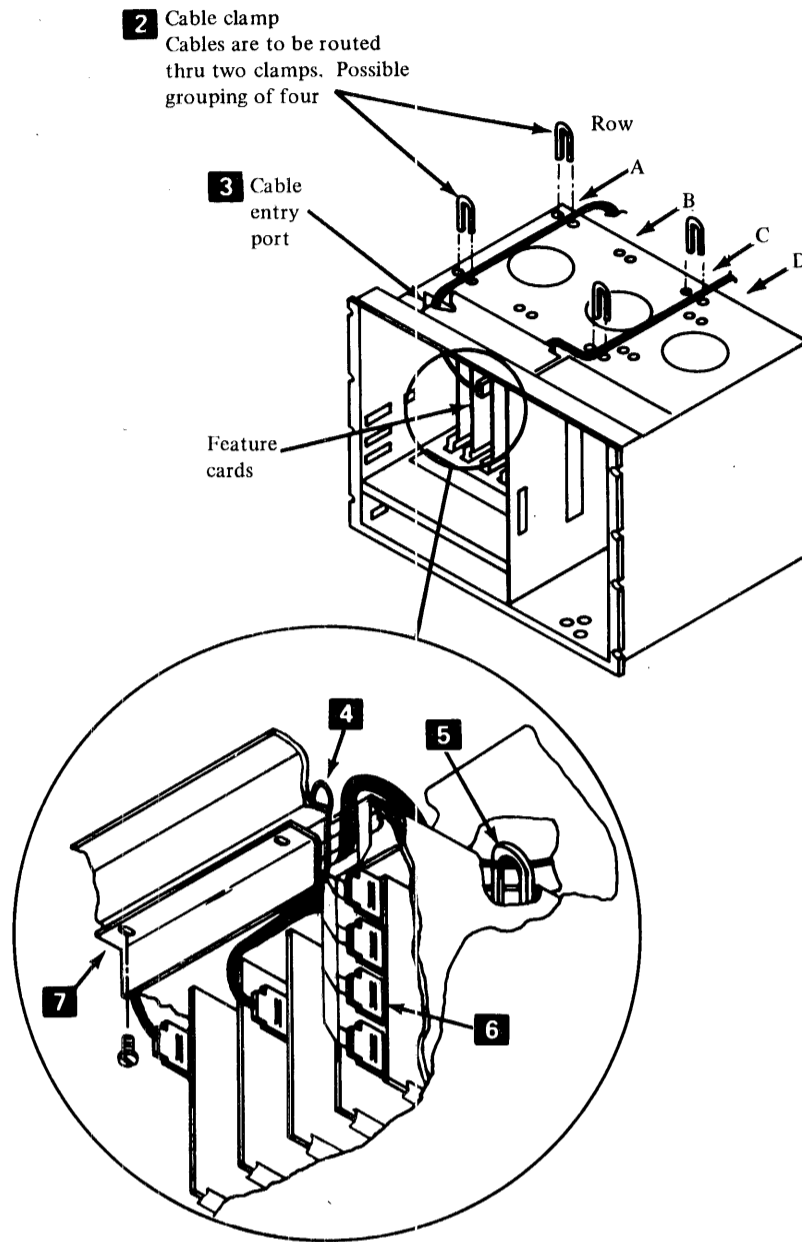
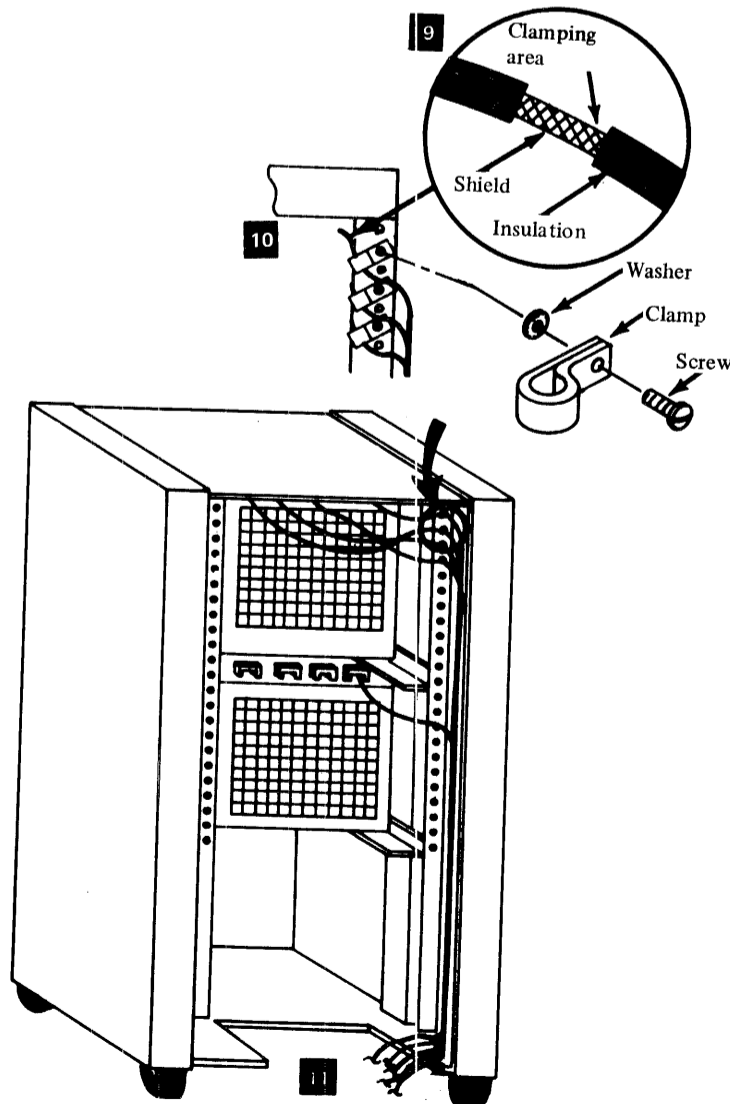

FIG. 3.2.2.0



ENG. CHANGE NO. 323200 327517 327517B
DATE OF CHANGE 23NOV81 08JAN82 12MAR82

3.3 CUSTOMER CABLING RESPONSIBILITY

THE IBM CUSTOMER ENGINEER DOES NOT CONNECT NON-IBM CABLES OR EQUIPMENT TO THE CUSTOMER ACCESS PANEL, ATTACHMENT CARDS, OR SENSOR I/O CARDS. THE FOLLOWING PROCEDURES ARE SUPPLIED SO THAT THE USER OR USER'S REPRESENTATIVE CAN COMPLETE THE INSTALLATION. CAUTION: GROUNDING CIRCUIT CONTINUITY MUST BE MAINTAINED. ON A SYSTEM WITH SENSOR I/O ATTACHMENTS, THE POWER PLUGS MUST NOT BE DISCONNECTED WITHOUT FIRST DISCONNECTING ALL USER INPUT/OUTPUT CIRCUITS. INFORMATION ON CUSTOMER CABLING REQUIREMENTS IS CONTAINED IN CUSTOMER SITE PREPARATION MANUAL GA34-0050.

SECTION 4.0 SYSTEM POWER

PRIMARY POWER GROUNDING AND CONTROLS

A) PRIMARY POWER GROUNDING

IBM RECOMMENDED GROUNDING AND POWER DISTRIBUTION ARE SHOWN IN THE CUSTOMER SITE PREPARATION MANUAL CHAPTER 5. THE PERFORMANCE OF IBM UNITS CAN BE AFFECTED BY ELECTRICAL NOISE AND/OR TRANSIENTS ENTERING THE SYSTEM UNITS FROM THE PRIMARY POWER GROUNDING NETWORK.

ALL IBM MACHINE POWER CORDS CONTAIN AN INSULATED EQUIPMENT GROUNDING CONDUCTOR (GREEN OR GREEN WITH YELLOW STRIPES) CONNECTED BETWEEN THE MACHINE FRAME GROUND AND A PIN ON THE POWER CORD PLUG. THE WALL OR CORD RECEPTACLES RECOMMENDED BY IBM PROVIDE CONNECTION TO THIS GROUND PIN. THIS GROUND PIN MUST BE PROPERLY TERMINATED TO PROVIDE AN INSTALLATION WHICH IS SAFE, RELIABLE, AND RELATIVELY UNAFFECTED BY ELECTRICAL NOISE.

HOWEVER, IN GBG/I COUNTRIES USING 50HZ POWER, AND IN JAPAN, CERTAIN CONFIGURATIONS PROHIBIT THE USE OF POWER PLUGS AND WALL RECEPTICLES. THESE EXCEPTIONS ARE AS FOLLOWS:

- . IN GBG/I COUNTRIES USING 50HZ POWER, THE GROUND CONDUCTOR LEAKAGE CURRENT MAY BE OF SOME CONCERN IF IT IS GREATER THAN 3.5 MILLIAMPERES. IF THIS GROUNDING CONDUCTOR CURRENT IS A CONCERN, SPECIAL CONSIDERATIONS MAY BE NECESSARY WHEN CONNECTING THE 4997 POWER CABLE TO THE A.C. POWER SOURCE. REFER TO APPENDIX H AND DETERMINE THE LEAKAGE CURRENT OF THE SYSTEM TO BE INSTALLED BEFORE PROCEEDING WITH THE INSTALLATION.
- . IN GBG/I COUNTRIES USING 50HZ POWER, IF THE GROUND CONDUCTOR LEAKAGE CURRENT IS GREATER THAN 1 AMPERE, THE SYSTEM CANNOT BE INSTALLED. HOWEVER, THIS CONDITION CANNOT OCCUR WITH SERIES/1.
- . IN JAPAN OTHER SPECIAL CONSIDERATIONS MUST BE TAKEN INTO ACCOUNT ALSO. IF JAPAN ONLY, REFER TO APPENDIX D BEFORE PROCEEDING WITH THE INSTALLATION.

TO MEET THE REQUIREMENTS FOR THE USAGE OF POWER PLUG AND WALL RECEPTICLES (IF IT HAS BEEN DETERMINED THAT THEY CAN BE USED), CONDITIONS DESCRIBED IN THE CUSTOMER SITE PREP MANUAL (CHAPTER 5) MUST BE MET.

B) INITIAL SYSTEM (CIRCUITS) GROUNDING AND CUSTOMER SIGNAL GROUNDING

IF THE SYSTEM BEING INSTALLED CONTAINS A 4982 (SENSOR I/O EQUIPMENT), ADDITIONAL GROUNDING AND SHIELDING PRECAUTIONS MUST BE TAKEN. REFER TO THE CUSTOMER SITE PREPARATION MANUAL, CHAPTER 7.

C) EMERGENCY POWER OFF CONTROL

IF AN IBM 4997 ENCLOSURE IS BEING INSTALLED, AN INSTANT POWER OFF (IPO) SWITCH IS PROVIDED WHICH WILL POWER OFF THE SINGLE BAY WITHIN TWO SECONDS AFTER PULLING THE IPO BUTTON. THE IPO BUTTON POWERS OFF ONLY THE UNITS MOUNTED WITHIN ITS 4997 RACK ENCLOSURE. IN SYSTEMS WITH MULTIPLE ENCLOSURES, THE IPO POWERS OFF ONLY THE UNITS MOUNTED WITHIN THAT SINGLE ENCLOSURE. SAFETY PRACTICES PREVENT ANY ENCLOSURE OR UNIT WITHIN THE ENCLOSURE FROM BEING POWERED BY ANOTHER ENCLOSURE. EACH ENCLOSURE MUST BE INDIVIDUALLY CONNECTED TO THE MAIN POWER SOURCE.

FOR INSTALLATIONS NOT USING AN IBM ENCLOSURE OR FOR NON-RACK MOUNTED DEVICES, CONTROLS FOR DISCONNECTING THE MAIN POWER SERVICE SUPPLYING THE COMPUTER EQUIPMENT SHOULD BE CONVENIENT TO THE OPERATOR.

D) LIGHTNING PROTECTION

IBM RECOMMENDS THAT THE USER INSTALL LIGHTNING PROTECTION ON HIS SECONDARY POWER SOURCE AND SIGNAL LINES THAT ARE EXPOSED TO LIGHTNING WHEN:

- . THE UTILITY COMPANY INSTALLS LIGHTNING PROTECTORS ON THE PRIMARY.
- . PRIMARY POWER IS SUPPLIED BY AN OVERHEAD POWER SERVICE.
- . THE AREA IS SUBJECT TO ELECTRICAL STORMS OR EQUIVALENT POWER SURGES.

THE USER SHOULD DETERMINE WHETHER LIGHTNING PROTECTION IS DESIRABLE, AND SELECT AND INSTALL THE SERVICE PROTECTOR NEEDED.

E) CONVENIENCE OUTLETS

A SUITABLE NUMBER OF CONVENIENCE OUTLETS SHOULD BE (AT REQUIRED LOCAL COUNTRY VOLTAGE) INSTALLED IN THE SYSTEM AREA. THESE CONVENIENCE OUTLETS SHOULD BE ON BUILDING CIRCUITS OTHER THAN THE COMPUTER POWER PANEL (OR RISER), OR LIGHTNING CIRCUITS.

OUTLETS FOR REMOTE IBM MACHINES (4973, 4974 AND 4979) OR STAND ALONE MACHINE (4952C) SHOULD BE SINGLE OUTLET RECEPTICLES TO DISCOURAGE INCORRECT APPLICATION.

F) ATTACHED EQUIPMENT (NON-IBM)

EQUIPMENT NOT SUPPLIED BY IBM BUT ATTACHED TO, OR MOUNTED IN, THE IBM ENCLOSURE MUST NOT USE OR SHARE A.C. OR D.C. POWER FROM THE INTERNAL SYSTEM POWER DISTRIBUTION PANEL-EXCEPT AS FOLLOWS:

*TEMPORARY POWER USE FOR SERVICE EQUIPMENT BEING USED BY EXPERIENCED MAINTENANCE PERSONNEL.

*I/O CHANNEL ATTACHMENT CARDS DESIGNED ACCORDING TO THE GUIDELINES CONTAINED IN S/1 USER ATTACH MANUAL (GA34-0033) TO MOUNT IN AN IBM PROCESSOR OR I/O EXPANSION CARD FILE MAY DRAW D.C. POWER FROM THAT UNIT.

MOUNTING NON-IBM EQUIPMENT IN THE SAME ENCLOSURE WITH IBM UNITS CAN AFFECT SYSTEM PERFORMANCE DUE TO ELECTRICAL NOISE, INCREASED THERMAL LOAD, OR ALTERED AIR-FLOW.

CAUTION: GROUNDING CIRCUIT CONTINUITY IS VITAL. ON A SYSTEM WITH 4982 (SENSOR I/O) ATTACHMENTS, THE POWER PLUGS MUST NOT BE DISCONNECTED WITHOUT FIRST DISCONNECTING ALL USER INPUT/OUTPUT CIRCUITS.

4.1 PREPOWER CHECKS.

CHECKING VOLTAGES AND RESISTANCES IN PRIMARY POWER CIRCUITS.

THE CUSTOMER ENGINEER MAY TAKE VOLTAGE AND RESISTANCE MEASUREMENTS AT THE FACE OF THE BRANCH CIRCUIT RECEPTACLE (CONNECTOR), BUT MUST NOT TAKE MEASUREMENTS INSIDE A CUSTOMER'S POWER PANEL, EQUIPMENT ROOM, MG POWER UNIT, OR SIMILAR AREA. ALSO, THE CE SHOULD NOT ENTER A CUSTOMER'S MECHANICAL EQUIPMENT ROOM TRANSFER VAULT, OR UNINTERRUPTIBLE POWER SOURCE BATTERY ROOM.

() A. CHECK OUT CUSTOMER RECEPTACLE OR CONNECTOR.

NOTE: IF A BUILDING GROUND IS NOT AVAILABLE IN THE IMMEDIATE AREA, TO DO THE FOLLOWING CHECKS, USE THE GROUND PIN IN THE CUSTOMER RECEPTACLE.

BRANCH CIRCUIT CB TURNED OFF CHECK

1. HAVE THE CUSTOMER LOCATE AND TURN OFF THE BRANCH CIRCUIT CB THAT FEEDS THE OUTLET. ATTACH "DO NOT OPERATE" TAG (2229-0237).

CAUTION: AVOID PHYSICAL CONTACT WITH THE CASE OF THE RECEPTACLE WITH ANYTHING OTHER THAN TEST PROBES UNTIL STEP 3 IS COMPLETED.

2. CHECK THE VOLTAGE FROM THE RECEPTACLE CASE COVER SCREW TO THE BUILDING GROUND FOR LESS THAN 1.0 VAC. (BEGIN WITH THE METER SCALE THAT IS APPROPRIATE FOR NORMAL LINE VOLTAGE CHECKS).
3. CHECK THE VOLTAGE FROM THE GROUND PIN TO THE BUILDING GROUND FOR LESS THAN 1.0 VAC. THE RECEPTACLE IS NOW SAFE TO TOUCH.
4. CHECK THE RESISTANCE FROM THE GROUND PIN TO THE RECEPTACLE CASE COVER SCREWS.

CHECK THE RESISTANCE FROM THE GROUND PIN TO THE BUILDING GROUND. A READING OF LESS THAN 1.0 OHM INDICATES THE PRESENCE OF A SAFE, CONTINUOUS GROUNDING CONDUCTOR.

CAUTION: AVOID CONTACT WITH INTERNAL PARTS (PINS AND SOCKETS) OF THE RECEPTACLE.

5. WITH THE CB STILL TURNED OFF, MEASURE THE PHASE-TO-PHASE VOLTAGE AND THE PHASE-TO-GROUND VOLTAGE.

MEASURE THE PHASE-TO-NEUTRAL VOLTAGE (IF PRESENT) AND THE NEUTRAL-TO-GROUND VOLTAGE (IF PRESENT).

ALL VOLTAGE VALUES ARE TO BE LESS THAN 1.0 VAC.

BRANCH CIRCUIT CB TURNED ON CHECK

CAUTION: DO NOT TOUCH THE RECEPTACLE BEFORE MEETING THE REQUIREMENTS OF STEPS 6 AND 7.

6. HAVE THE CUSTOMER TURN ON THE CB THAT SUPPLIES VOLTAGE TO THE RECEPTACLE.
7. MEASURE THE VOLTAGES FROM THE SHELL TO THE BUILDING GROUND TO NEUTRAL (IF PRESENT). VOLTAGE VALUES ARE TO BE LESS THAN 1.0 VAC.

CAUTION: IF MEASURED VOLTAGE VALUES ARE LESS THAN 1.0 VAC, THE RECEPTACLE CAN BE TOUCHED. AVOID CONTACT WITH THE INTERNAL PARTS (PINS AND SOCKETS) OF THE RECEPTACLE.

() B. CHECK OUT IBM MACHINE POWER PLUG.

THE POWER PLUG ON THE MACHINE POWER CABLE MUST BE CHECKED TO ENSURE THAT

VOLTAGE HAS NOT BEEN APPLIED TO THE MACHINE FROM ANOTHER SOURCE, SUCH AS ANOTHER IBM MACHINE OR A NON-IBM ALTERATION OR ATTACHMENT, EITHER DIRECTLY OR THROUGH THE CHANNEL.

CAUTION: DO NOT TOUCH THE PLUG SHELL UNTIL THE REQUIREMENT IN STEP 1 IS MET.

1. MEASURE THE VOLTAGE FROM THE SHELL AND THE GROUND PIN TO THE BUILDING GROUND. IF VOLTAGE VALUES ARE LESS THAN 1.0 VAC, THE PLUG SHELL CAN BE TOUCHED.

CAUTION: AVOID CONTACT WITH INTERNAL PINS.

2. MEASURE THE VOLTAGE FROM THE PHASE PINS TO THE GROUND PIN AND THE NEUTRAL PIN (IF PRESENT). ALL VOLTAGE VALUES ARE TO BE LESS THAN 1.0 VAC.
3. MEASURE THE RESISTANCE BETWEEN THE GROUND PIN AND THE MACHINE FRAME FOR LESS THAN 1.0 OHM.

NOTE: IF THE REQUIREMENTS IN STEPS 1 THROUGH 3 ARE MET, THE PLUG IS SAFE.

() C. MEASURE CUSTOMER PRIMARY POWER.

BRANCH CIRCUIT CB TURNED ON CHECK.

CAUTION: AVOID CONTACT WITH THE INTERNAL PARTS (PINS AND SOCKETS) OF THE RECEPTACLE.

1. MEASURE THE VOLTAGES FROM THE GROUND PIN AND THE NEUTRAL PIN (IF PRESENT) TO ALL PHASES. ENSURE THAT THE VALUES ARE ACCEPTABLE FOR THE MACHINE USING THEM. (REFER TO TABLE 1).
2. MEASURE THE PHASE-TO-PHASE VOLTAGE. ENSURE THAT THE VALUES ARE ACCEPTABLE FOR THE MACHINE USING THEM. (REFER TO TABLE 1).

NOTE: IF THE REQUIREMENTS IN STEPS 1 AND 2 ARE MET, HAVE THE CUSTOMER BRANCH CIRCUIT CB TURNED OFF BEFORE CONNECTING THE PLUG INTO THE CUSTOMER RECEPTACLE OR CONNECTOR.

() D. VERIFY THAT THE MACHINE VOLTAGE LABELS AND CUSTOMER'S SERVICE VOLTAGES ARE EQUAL.

SOME POWER SUPPLIES ARE LIMITED TO SPECIFIC AC INPUT VOLTAGES. THEREFORE, THE INPUT VOLTAGES FOR THE FOLLOWING PRODUCTS MUST BE MEASURED AS SHOWN IN TABLE 1.

- 4952A (PROCESSOR (BELOW S/N 50,000) - REMOVE THE BACK COVER. THE "THIS MACHINE IS WIRED FOR ___ VAC" LABEL IS ON THE BACK OF THE TRANSFORMER BOX.
- 4962 (DISK STORAGE) - PULL THE UNIT OUT FROM THE RACK ENCLOSURE AND REMOVE THE OUTER COVER. LOCATE THE "THIS MACHINE IS WIRED FOR ___ VAC" LABEL ON THE VOLTAGE BARRIER TERMINAL STRIP.
- 4963 (DISK SUBSYSTEM) - REMOVE DECORATIVE COVERS AND UNIT SAFETY COVER, AND LOCATE LABEL "THIS MACHINE IS WIRED FOR ___ VAC" ON TOP SURFACE OF POWER SUPPLY.
- 4964 (DISKETTE) OR 4966 (DISKETTE MAGAZINE) - PULL THE UNIT 1/2 OUT OF THE RACK ADAPTER. LOCATE THE "THIS MACHINE IS WIRED FOR ___ VAC" LABEL ON TOP OF THE UNIT'S OUTER COVER.
- 4969-7X (TAPE DRIVE) FROM THE REAR OF THE MACHINE AT THE LOWER RIGHT HAND CORNER, LOCATE THE "THIS MACHINE IS WIRED FOR ___ VAC" LABEL. IF THIS IS DRIVE ONE WITH CONTROLLER FEATURE, THEN THE CONTROLLER COVER MUST BE REMOVED TO GAIN ACCESS TO THE LABEL.
- 4969-4X (TAPE DRIVE) ON THE TAPE DRIVE POWER SUPPLY NEXT TO TB5, LOCATE THE "THIS MACHINE IS WIRED FOR ___ VAC" LABEL. THE POWER SUPPLY IS MOUNTED ON REAR OF THE CASTING INSIDE THE TAPE DRIVE.
- 4982 (SENSOR I/O) - REMOVE THE FRONT COVER AND OPEN THE GATE. LOCATE THE "THIS MACHINE IS WIRED FOR ___ VAC" LABEL ON THE FRONT OF THE POWER SUPPLY.
- 4987 (PROGRAMMABLE COMMUNICATIONS SUBSYSTEM) - REMOVE THE FRONT COVER. LOCATE THE "THIS MACHINE IS WIRED FOR ___ VAC" LABEL ON THE FRONT OF THE POWER SUPPLY ABOVE THE FUSES.
- 4993 (TERMINATION ENCLOSURE) - REMOVE FRONT COVER. REMOVE THE POWER SUPPLY RETAINING CLAMP AND SLIDE POWER SUPPLY OUT. THE "THIS MACHINE IS WIRED FOR ___ VAC" LABEL IS LOCATED ON THE TOP OF THE PRIMARY POWER BOX.

IF VOLTAGE CHANGES ARE TO BE MADE TO THE POWER SUPPLY TO EQUAL THE AC INPUT SERVICE VOLTAGES, YOU ARE TO INSTALL AN IBM FFBM VOLTAGE CONVERSION (FIELD FEATURE BILL MATERIAL).

ENG. CHANGE NO. 323200 327517 327517B
 DATE OF CHANGE 23NOV81 08JAN82 12MAR82

60HZ AC INPUT VOLTAGE
 (NOT APPLICABLE FOR HI FREQUENCY POWER SUPPLIES)

	MACHINE VOLTAGE LABEL (NOMINAL INPUT)	ACCEPTABLE RANGE	
		HIGH	LOW
LOW VOLTAGE	100 VOLT AC	110	90
	110 VOLT AC	119	96.5
	120 VOLT AC	127	104
	127 VOLT AC	137	111
HIGH VOLTAGE	200 VOLT AC	220	180
	208 VOLT AC	220	180
	220 VOLT AC	238	193
	240 VOLT AC	254	208

50HZ AC INPUT VOLTAGE
 (NOT APPLICABLE FOR HIGH FREQUENCY POWER SUPPLIES)

	MACHINE VOLTAGE LABEL (NOMINAL INPUT)	ACCEPTABLE RANGE	
		HIGH	LOW
LOW VOLTAGE	100 VOLT AC	110	90
	110 VOLT AC	119	96.5
HIGH VOLTAGE	200 VOLT AC	220	180
	220 VOLT AC	238	193
	230 VOLT AC	249	202
	240 VOLT AC	259	210

NOTE: THE 4952A (S/N 50,000 AND ABOVE), 4952B, 4952C, 4953, 4954, 4955, 4959 AND 4965 USE A HIGH FREQUENCY POWER SUPPLY AND AS SUCH ARE NOT SENSITIVE TO ABSOLUTE VOLTAGES BUT RATHER OPERATE OVER A RANGE OF VOLTAGES. AS SUCH, THE INSTALLER IS TO INSURE THAT THE CORRECT LEVEL OF THE MACHINE MATCHES THE AC INPUT LEVEL, ONLY (HI OR LOW).

- . LOW = 90 - 137 VOLTS (NOMINAL 110V)
- . HI = 180 - 254 VOLTS (NOMINAL 220V)

TABLE 1.

4.2 SWITCH ON POWER

SWITCH ON AC POWER TO THE SYSTEM INCLUDING ALL I/O UNITS AS FOLLOWS:

- () 1. SWITCH OFF ALL THE MAIN POWER SWITCHES FOR EACH UNIT.
- () 2. INSERT FREE END OF THE AC POWER CABLES INTO CUSTOMER SERVICE OUTLETS.
- () 3. SET THE RACK EMERGENCY PULL (INSTANT POWER OFF) CIRCUIT BREAKER INTO THE REAR OF THE RACK TO THE ON POSITION.
- () 4. SWITCH ON ALL SWITCHES, ONE AT A TIME WITH PROCESSOR LAST.

NOTE: MAKE SURE THE DEVICE FAN UNITS ARE WORKING BY VISUALLY CHECKING THEM FROM THE REAR OF THE RACK.

IF POWER DOES NOT COME ON, SEE POWER SUPPLY MAP CHARTS FOR CORRECTING POWER SUPPLY PROBLEMS. IF ALL VOLTAGES ARE NOT PRESENT, THE POWER WILL GO OFF. A DC VOLTMETER OF +/-1% TOLERANCE SHOULD BE USED (SUCH AS SIMPSON MODEL 260, WESTON 901, FLUKE MODEL 885A/CC).

4.3 ADJUST OVERCURRENT SETTING

REFER TO FIGURES 4.4.1.0 AND 4.4.2.0. ADJUST THE OVERCURRENT SETTING ON THE SEQUENCE AND CONTROL CARD ON BOTH THE FULL WIDTH AND HALF WIDTH CARD FILES (125 WATT-4953A, C AND 300 WATT 4953B, D; 4955 A-D) AND ON THE ICW VOLTAGE CARD (400 WATT, 4952B (S/N 15400 AND BELOW), 4955E), ONLY IF FEATURES ARE ADDED TO THE PRODUCT BEYOND THE ORIGINAL PLANT ORDER.

NOTE: DO NOT ADJUST IF FEATURE CARDS ARE NOT ADDED TO THE MACHINE BEYOND ORIGINAL PLANT SHIPMENT CONFIGURATION.

- () 1. TURN THE CURRENT LIMIT POTENTIOMETER, FIGURE 4.4.2.0 -125 AND 300 WATT: (3), FIGURE 4.4.1.0 -400 WATT) ON THE SEQUENCE AND CONTROL CARD OR LOW VOLTAGE CARD COUNTERCLOCKWISE UNTIL THE POWER UNIT POWERS OFF.
- () 2. TURN THE POTENTIOMETER 8 FULL TURNS CW (CLOCKWISE) FOR 4953A AND C (125 W); 4 FULL TURNS CW FOR 4953B AND D AND 4955A (300W): 7 FULL TURNS CW FOR 4952B (S/N 15400 AND BELOW) 4955E (400W).
- () 3. SWITCH POWER OFF AND THEN ON.

4.4 ADJUST +/-5 VOLTS DC POTENTIOMETER

IF THE +5 VOLT DC POTENTIOMETER, FIGURE 4.4.2.0 (LOCATED ON THE POWER SUPPLY SEQUENCE AND CONTROL CARD FOR THE 125 WATT AND 300 WATT SUPPLIES AND ON THE LOW VOLTAGE CARD FOR THE 400 WATT SUPPLY) FIGURE 4.4.1.0 IS NOT SEALED, ADJUST IT BETWEEN 5.0 AND 5.2 VDC. MEASURE THE VOLTAGE USING THE TABLE 4.6.1.0 (THERE IS NO ADJUSTMENT ON 4952A).

4.5 4952A MINIMUM LOAD SWITCH

THE MINIMUM LOAD SWITCH MUST BE IN AN ON (UP) POSITION IF 4 LOGIC CARDS OR LESS ARE PLUGGED INTO THE BOARD. THE SWITCH MUST BE IN THE OFF (DOWN) POSITION IF 5-6 CARDS ARE PLUGGED INTO THE BOARD. TO CHECK FOR THE CORRECT SWITCH POSITION, REMOVE THE REAR COVER AND DROP THE HINGED TRANSFORMER BOX DOWN.

ENG. CHANGE NO. 323200 327517 327517B
 DATE OF CHANGE 23NOV81 08JAN82 12MAR82

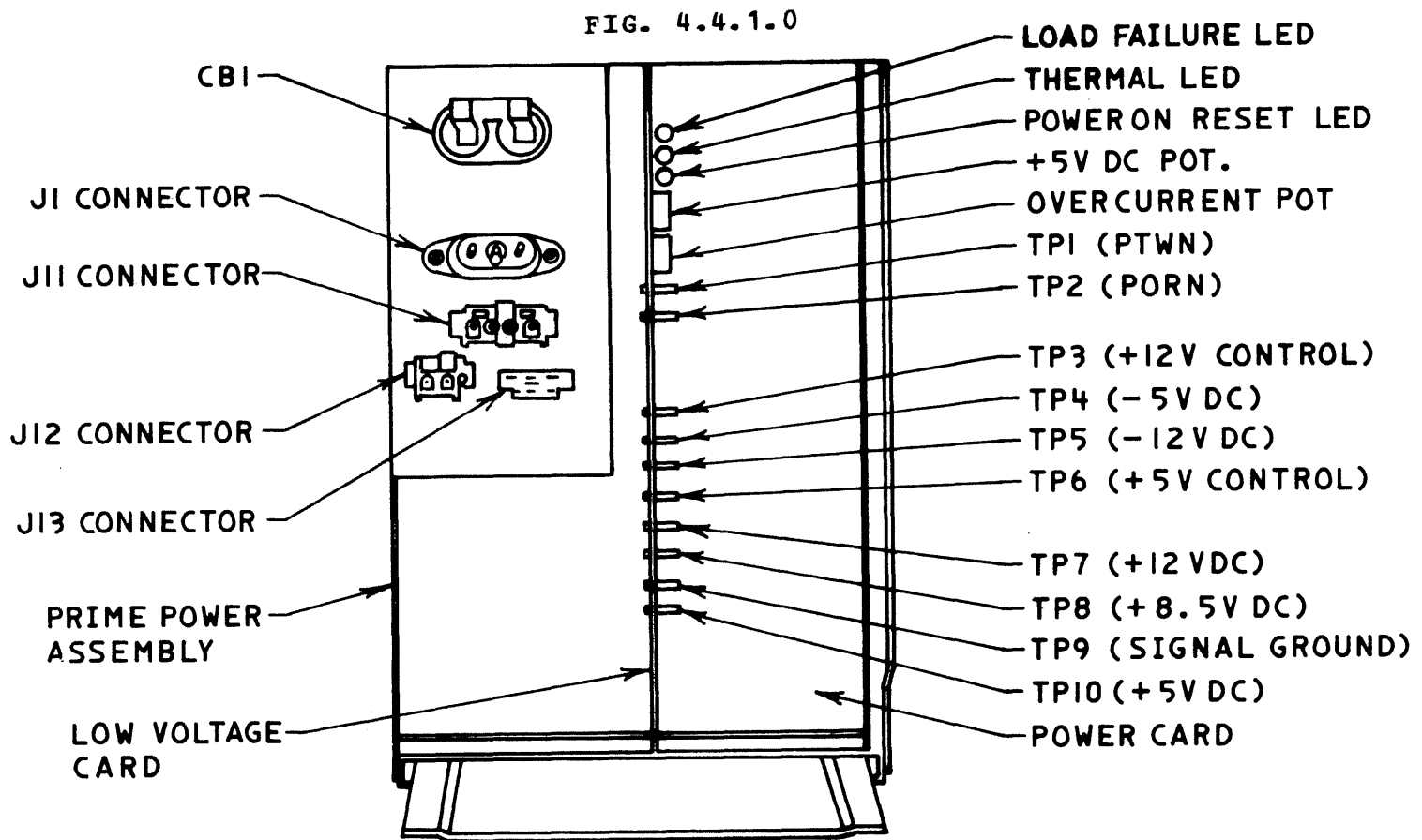

SEQUENCE AND CONTROL CARD - 400 WATT

FIG. 4.4.2.0

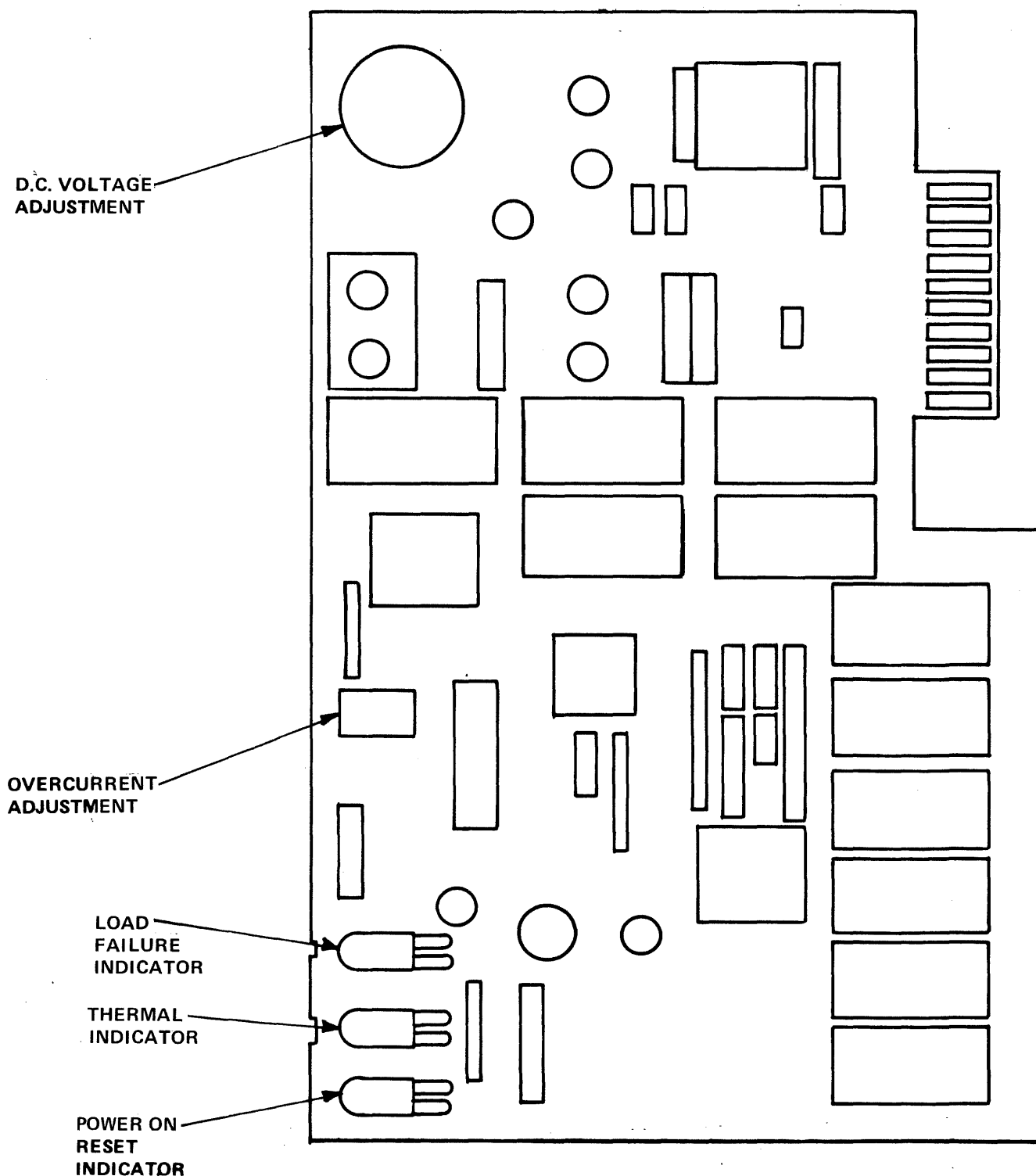

SEQUENCE AND CONTROL CARD - 125 AND 300 WATT

4.6 MEASURE DC VOLTAGES

REFER TO TABLE 4.6.1.0.

DC VOLTAGE RANGE AT EACH LEVEL AS MEASURED ON THE BOARD PINS ARE:

+5.0 = (+4.5 TO +5.5 VOLTS)	B2 D03
+8.5 = (+9.35 TO +7.82 VOLTS)	B2 G11
-5.0 = (-5.5 TO -4.55 VOLTS)	B2 G06
+12.0 = (+13.2 TO +10.92 VOLTS)	B2 B11
-12.0 = (-13.2 TO -10.92 VOLTS)	B2 B06
GROUND	B2 D08

IF VOLTAGES ARE NOT WITHIN SPECIFICATIONS,
REFER TO THE MAINTENANCE MAPS.

TABLE 4.6.1.0

CAUTION: IF A SIGNAL AND VOLTAGE PIN ARE CONNECTED BY A SHORT CIRCUIT, ONE OF THE PROCESSOR CARDS WILL BE DESTROYED.

SWITCH OFF POWER BEFORE THE BACKPANEL COVER IS REMOVED. SWITCH POWER ON AFTER THE COVER IS REMOVED AND PERFORM THE STEPS BELOW, SWITCH OFF POWER AND REINSTALL COVER AFTER YOU END THIS SECTION. IT IS RECOMMENDED THAT THE PIN EXTENDER P/N 2594238 (SHIPPED IN THE PROCESSOR SHIP GROUP) BE USED WHEN TESTING VOLTAGES ON THE PIN SIDE OF THE BOARD.

MEASURE EACH DC VOLTAGE. USE TABLE 4.6.1.0 TO DETERMINE THE CORRECT TEST POINTS FOR THE PROCESSOR AND/OR I/O EXPANSION UNIT THAT YOU ARE INSTALLING.

ENSURE THAT THE +8.5 VDC, -5 VDC, +12 VDC, AND -12 VDC VOLTAGES WILL ALWAYS BE PRESENT ON THE 4952A, B, C, 4953A, 4954A, 4, C, 4955E AND F BUT, FOR THE 300 WATT, ONLY IF THE OPTIONAL +/-12V REGULATOR CARD IS INSTALLED. THIS REGULATOR CARD IS THE LEFTMOST CARD POSITION ON THE FRONT OF THE POWER SUPPLY. NOTE THAT THESE FOUR VOLTAGES ARE NOT ADJUSTABLE.

4.7 HALF WIDTH CARD FILES

NOTE: THERE IS NO ADJUSTMENT OF D.C. VOLTAGES ON THE 4952A AND 4954A IF VOLTAGES ARE NOT IN TOLERANCE, CHECK LINE VOLTAGE AND FREQUENCY.

THE +/- 12 VOLTS ARE ALWAYS PRESENT ON ALL HALF WIDTH CARD FILES. ALL DC VOLTAGES OF THE 4953 MODELS A AND C ARE ADJUSTED BY ADJUSTING THE POTENTIOMETER ON THE POWER SUPPLY SEQUENCE AND CONTROL CARD. OBSERVE THE VOLTAGE ON J11 PIN 1. THE J11 CONNECTOR IS LOCATED ON THE FRONT OF THE POWER SUPPLY; PIN 1 IS ON THE LEFT SIDE OF J11. THE VOLTAGE ON THIS PIN RELATIVE TO GROUND WILL BE +5V +/- 0.5V WHEN THE POTENTIOMETER IS CORRECTLY SET. ALL DC OUTPUT VOLTAGES WILL BE IN TOLERANCE WHEN THIS IS DONE.

SECTION 5.0 SYSTEM VERIFICATION

THIS SECTION GIVES A SUMMARY OF THE PROCEDURE FOR SYSTEM VERIFICATION OF HARDWARE WITH DIAGNOSTIC ROUTINES.

SYSTEMS VERIFICATION STARTS WITH AN INTERNAL TEST OF THE BASIC PROCESSOR OPERATIONS, AND A TEST OF THE PROGRAM LOAD CAPABILITY. THE TESTING CONTINUES OUTWARD FROM THE PROCESSOR TO INCLUDE ALL PARTS OF THE SYSTEM.

THE MAINTENANCE DOCUMENTS ARE INCLUDED TO AID IN DETERMINING AND LOCATING PROBLEMS IF THE SYSTEM DOES NOT PERFORM CORRECTLY DURING ITS TEST.

ONE OF THE DISKETTE UNITS ON THE SYSTEM IS USED TO LOAD THE TEST DISKETTES.

IF A DISKETTE UNIT IS NOT A PART OF THE SYSTEM, THEN THE DISKETTE MAINTENANCE PROGRAM LOAD DEVICE P/N 1635514 MAY BE USED.

A NON-IBM DEVICE CANNOT BE USED TO INSTALL AND VERIFY THE SYSTEM WITHOUT SPECIFIC PERMISSION FROM THE CUSTOMER. IF THE ONLY AVAILABLE ALTERNATE CONSOLE DEVICE ON THE SYSTEM IS AN OEM DEVICE OBTAIN THE CUSTOMER'S PERMISSION OR USE THE PROGRAMMER CONSOLE. SEE 07.01.00 OF MAP 0010 FOR MESSAGE AND RESPONSE PROCEDURES FOR PROGRAMMER CONSOLE OPERATION.

INSIDE THE MACHINE SHIP GROUP ARE THE FOLLOWING DISKETTES WHICH ARE USED TO VERIFY THAT THE MACHINE IS OPERATIONAL:

1. DIAGNOSTIC DISKETTE (ONE OR MORE). A DIAGNOSTIC DISKETTE IS SHIPPED WITH ALL SYSTEMS. THIS DISKETTE IS PRECONFIGURED TO MATCH THE SYSTEM. IF ANY CHANGES ARE MADE TO THE SYSTEM, THE DISKETTE IS TO BE CHANGED TO MATCH THE SYSTEM. THE PERSON INSTALLING THE CHANGES WILL ENTER THE REAL DEVICE INFORMATION AS SPECIFIED IN DESCRIPTION (MAP 3880)
2. SYSTEM TEST DISKETTE

THE SYSTEM TEST IS ON A SEPARATE DISKETTE. THE PURPOSE OF THE SYSTEM TEST IS TO RUN DEVICE EXERCISERS IN AN OVERLAP MODE UNDER A SYSTEM TEST SUPERVISOR (REFER TO MAP 0015).

TEST SEQUENCE.

- () 1. ENTER THE SYSTEM ENTRY MAP, (MAP 0020, ENTRY POINT A) AND EXECUTE THE PROCESSOR AND STORAGE TESTS.
- () 2. IF CONFIGURATION ERRORS OCCUR DURING THE CONFIGURATOR PROGRAM AUTOMATIC VERIFY, FOLLOW THE DIAGNOSTIC MAPS AND SEE:
 - . MAP 3880 (CONFIGURATION PROGRAM DESCRIPTION).
 - . MLD (ADDRESS AND OPTION JUMPERING).
- () 3. WHEN THE DISKETTE HAS THE CORRECT CONFIGURATION, RUN DISK VERIFICATION PROGRAM (7869 OR 7A69), IF APPLICABLE.
- () 4. AT THE END OF DISK VERIFICATION, RUN CE DISK INITIALIZATION PROGRAM 78F0 IF 4962 IS INSTALLED.
- () 5. SELECT AUTOMATIC MODE WITHOUT OPTIONS.
- () 6. WHEN A GOOD AUTOMATIC RUN HAS BEEN COMPLETED, SEE THE MAP PROLOG FOR EACH OF THE INSTALLED DEVICES (LOCATED IN BINDER MIM FOLLOWING THE SERVICE GUIDE) AND RUN MANUAL TESTS.

NOTES:

1. THE CONFIGURATOR PROGRAM AUTOMATIC VERIFY OPERATION DOES NOT CHECK SYSTEM DATA (IN ENTRY 00) OR DEVICE DATA (IN ENTRY 00) OR DEVICE DATA (IN ENTRY 01-XX). ERRORS IN THIS DATA WILL CAUSE MAP ERRORS.
2. WHEN THE BASIC DISKETTE HAS BEEN CONFIGURATED, COPY THE CONFIGURATION RECORD TO THE SYSTEM TEST DISKETTE AND ANY SECONDARY DIAGNOSTIC DISKETTE(S).
- () 7. IF AN OEM DEVICE IS AVAILABLE, IT CAN NOW BE ASSIGNED THE ALTERNATE CONSOLE OPERATION (SEE MAPS 3880 AND 3881).
- () 8. SEE SYSTEM TEST USER'S GUIDE, VOLUME SYT 04, EXECUTE SYSTEM TEST, STARTING AND STOPPING ON DEVICE ADDRESSES UNTIL ALL DEVICES HAVE BEEN TESTED IN COMBINATION WITH (ALL/SEVERAL) OTHER DEVICES. EACH DEVICE SHOULD RUN A TOTAL OF AT LEAST TWO MINUTES.

SYSTEM INSTALLATION TESTING IS COMPLETE.

COVERS

REINSTALL ALL COVERS BEFORE PERMITTING THE CUSTOMER TO USE THE SYSTEM.

AFTER INSTALLATION

ENG. CHANGE NO. 323200 327517 327517B
DATE OF CHANGE 23NOV81 08JAN82 12MAR82

RECORD UPDATING

- () 1. COMPLETE INSTALLATION RECORDS AND REPORT THAT THE INSTALLATION IS COMPLETE TO THE BRANCH OFFICE.
- () 2. INSTALL THESE PROCEDURES IN THE MLD (ICGIC VOL. 1) BINDER FOR FUTURE REFERENCE.

SHIPPING MATERIAL DISPOSITION

- () SHIPPING MATERIAL DISPOSITION IS THE RESPONSIBILITY OF THE CUSTOMER.

ENG. CHANGE NO. 323200 327517 327517B
DATE OF CHANGE 23NOV81 08JAN82 12MAR82

APPENDIX A

HARDWARE INSTALLATION RULES

- A) INSTALL THE 4993 (TERMINATION ENCLCSURE) IN THE LOWER MOST POSITION IN THE RACK.
- C) INSTALL THE 4962 (DISK STORAGE DEVICE) OR 4963 (DISK SUB-SYSTEM), AT THE LOWER LOCATION(S) OF THE RACK, BUT ABOVE THE 4993. IF FEATURED, THIS UNIT SHOULD BE INSTALLED BEFORE OTHER UNITS IN THE RACK (SAFETY). (REFER TO PUBLICATION #S131-0602). IT IS SUGGESTED THAT THE TOP OF THE UNIT SHOULD NOT MEASURE MORE THAN 41.5 INCHES FROM THE FLOOR (37 INCHES (940 MM) FOR THE 4963). REMOVE PACKING AND UNLOCK ACTUATOR AND SPINDLE PEF DEVICE INSTALLATION INSTRUCTIONS. NOTE: DO NOT UNLOCK THE SPINDLE AND ACTUATOR UNTIL THE 4962 OR 4963 IS MOUNTED.
- C) INSTALL THE 4966 AT THE LOWER LOCATIONS BUT ABOVE THE 4962 (DISK STORAGE DEVICE) OR THE 4963 (DISK SUB-SYSTEMS) IF FEATURED. IT IS SUGGESTED THAT THE TOP OF THE UNIT SHOULD NOT MEASURE MORE THAN 60 INCHES FROM THE FLOOR.
- D) INSTALL PROCESSORS AND I/O EXPANSION UNITS ADJACENT TO ONE ANOTHER. UNITS SHOULD BE INSTALLED VERTICALLY OR HORIZONTALLY ADJACENT TO ONE ANOTHER.
- E) INSTALL PROCESSORS AND I/O EXPANSION CARD FILE UNITS IN THE TOPMOST LOCATIONS OF THE RACK.
- F) INSTALL ALL HALF-WIDE DEVICES INTO THE RACK MOUNTING FIXTURE P/N 1632229.
- G) INSTALL HALF-WIDE PROCESSORS TO THE LEFT SIDE OF THE RACK MOUNTING FIXTURE.

ENG. CHANGE NO. 323200 327517 327517B
DATE OF CHANGE 23NOV81 08JAN82 12MAR82

APPENDIX B

MACHINE INSTALLATION IN O.E.M. (NON-IBM RACK).

FULL WIDTH UNIT INSTALLATION (*) :

VERIFY THAT HORIZONTAL UNIT SUPPORTS ARE INSTALLED IN RACK.

MOUNT THE UNIT FROM THE FRONT OF THE RACK AND FASTEN WITH EIGHT BLACK #10-32 SCREWS. (SEE FIGURE 1). (4 SCREWS FOR 4993).

ENSURE THAT THE MOUNTING SCREWS ARE FIRMLY TIGHTENED SO AS TO MAKE GOOD ELECTRICAL GROUND BETWEEN THE CARD FILE AND THE RACK.

(*) FOR SPECIFIC INSTRUCTIONS, REFER TO THE APPROPRIATE INSTALLATION INSTRUCTIONS FOR EACH UNIT.

NOTE: IF ANY NON-RACK MOUNTED DEVICES ARE TO BE INSTALLED AT THIS TIME ALSO, IT IS ADVISABLE TO WAIT UNTIL THE UNIT'S SIGNAL CABLES ARE ROUTED PRIOR TO FASTENING DOWN THE CARD FILE.

FIG. 1

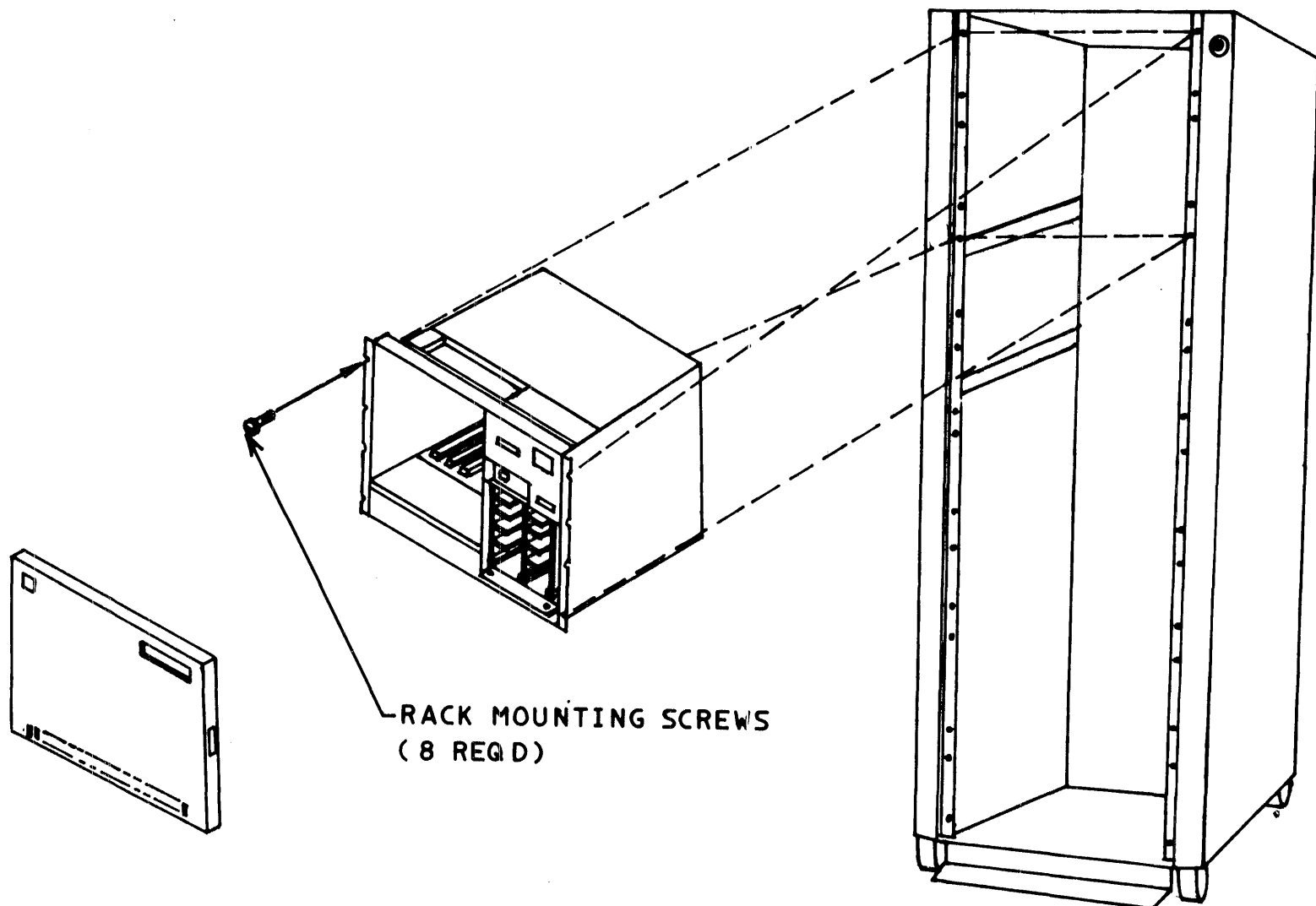

FULL WIDTH CARD FILE INSTALLATION

ENG. CHANGE NO. 323200 327517 327517B
DATE OF CHANGE 23NOV81 08JAN82 12MAR82

HALF WIDE UNIT INSTALLATION (*) :

VERIFY THAT HORIZONTAL UNIT SUPPORTS ARE INSTALLED ON RACK.

MOUNT THE RACK MOUNTING FIXTURE (FEATURE CODE #4540) FROM THE FRONT OF THE RACK AND FASTEN WITH EIGHT BLACK #10-32 SCREWS (SEE FIGURE 2).

ENSURE THAT THE MOUNTING SCREWS ARE FIRMLY TIGHTENED SO AS TO MAKE GOOD ELECTRICAL GROUND BETWEEN THE HALFWIDE UNITS AND THE FIXTURE.

MOUNT HALF WIDE UNITS INTO THE MOUNTING FIXTURE AND FASTEN WITH FOUR BLACK #10-32 SCREWS (SEE FIGURE 3).

FOR 4952A, (S/N 49,999 AND BELOW) LOWER POWER SUPPLY, ADD A SCREW (#10/32 - P/N 332620) THRU A HOLE IN THE BOTTOM OF THE CARD FILE INTO THE BOTTOM OF THE RACK MOUNTING FIXTURE.

FOR 4952A (S/N 50000 AND ABOVE) AND 4954A, REMOVE REAR COVER, ADD A SCREW (#10-32 - P/N 332620) THRU HOLE IN BRACKET AT REAR OF CARD FILE INTO THE BOTTOM OF THE RACK MOUNTING FIXTURE.

ENSURE THAT THE MOUNTING SCREWS ARE FIRMLY TIGHTENED SO AS TO MAKE GOOD ELECTRICAL GROUND BETWEEN THE FIXTURE AND THE RACK.

IT SHOULD BE NOTED THAT THE 4964 SERVICE GUIDE PIN IS TO BE INSTALLED TO THE RACK MOUNTING FIXTURE PRIOR TO THE UNIT BEING INSTALLED. REFER TO THE 4964 DISKETTE INSTALLATION INSTRUCTION DOCUMENT.

ADJUST FRONT COVER BY LOOSENING SCREWS AND BRACKET LATCH, CENTERING THE ON-OFF SWITCH AND RETIGHTEN.

(*) FOR SPECIFIC INSTRUCTIONS REFER TO THE APPROPRIATE INSTALLATION INSTRUCTION FOR EACH UNIT.

NOTE: IF ANY NON-RACK MOUNTED DEVICES ARE TO BE INSTALLED AT THIS TIME ALSO; IT IS ADVISABLE TO WAIT UNTIL THE UNIT'S SIGNAL CABLES ARE ROUTED PRIOR TO FASTENING DOWN THE CARD FILE .

FIG. 2

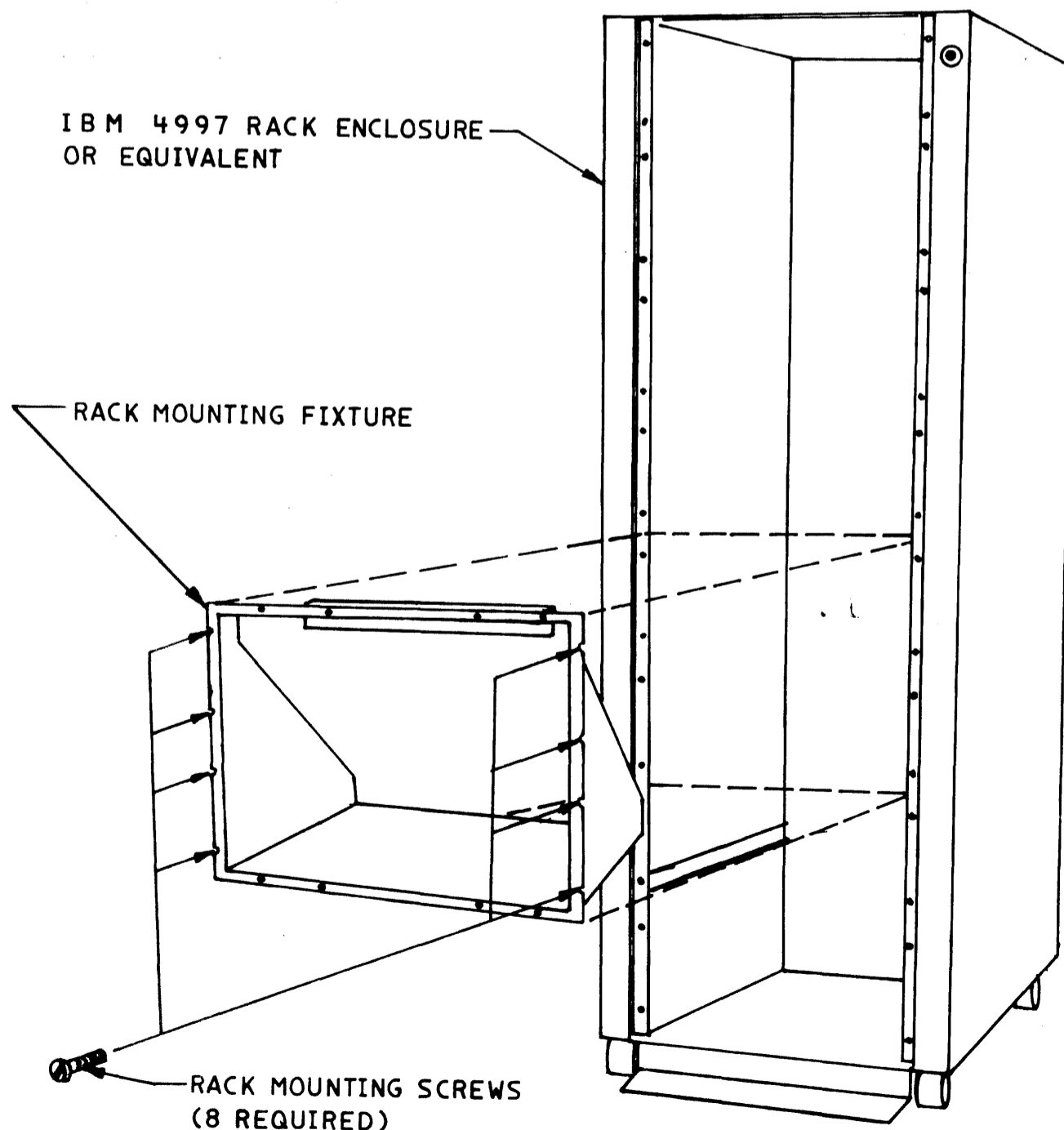

RACK MOUNTING FIXTURE INSTALLATION

APPENDIX C

FEATURE INSTALLATION SUMMARY

DUE TO THE LARGE NUMBER OF FEATURES AND OPTIONS AVAILABLE ON THE SERIES/1, THESE INSTALLATION INSTRUCTIONS WILL NOT ATTEMPT TO DESCRIBE PROCEDURES FOR INSTALLING EACH FEATURE.

NECESSARY INFORMATION FOR INSTALLING FEATURES MAY BE FOUND IN:

- . MAP PROLOGS
- . MLD PAGES
- . FEATURE LOCATION/DEVICE ADDRESS PRIORITY PAGES
(MAP PLUG P/N 4412857)
- . CE HANDBOOK - G229-8079

C.0 D/C 7900 FEATURE CABLING (TWO CHANNEL SWITCH)

NOTES:

- A) WHEN ATTACHING TWO CHANNEL SWITCH SPECIAL CONSIDERATIONS ARE NECESSARY AS TO WHERE THE D/C 7900 (TWO CHANNEL SWITCH) CAN BE IN RELATION TO THE TWO PROCESSORS IT SUPPORTS.

BEFORE INSTALLATION IT MUST BE DETERMINED HOW MANY UNITS AND BAYS ARE PRESENT TO ASSEMBLE THE UNIT(S) INTO THEIR CORRECT LOCATION USING THE FOLLOWING GUIDELINES.

1. HOW TO DETERMINE WHAT A UNIT IS BY LOOKING AT THE SYSTEM MLC.
PROCESSOR:

NOTE: D/C 92AA WHERE AA IS THE NUMBER OF PROCESSORS
D/C 93BB WHERE BB IS THE SEQUENCE OR PRIORITY NUMBER OF THE
PROCESSOR.

IF 92AA IS NOT PRESENT, THEN THERE IS ONLY ONE PROCESSOR.
IF 92AA IS 9201, THERE IS ONLY ONE PROCESSOR; AND
IF 92AA IS 9202, THERE ARE 2 PROCESSORS IN SERIES/1; AND IF 92AA IS 9203,
THERE ARE 3 PROCESSORS IN SERIES/1; AND SO ON.

IF 93BB IS NOT PRESENT, THEN THERE IS ONLY ONE PROCESSOR.

IF 93BB IS 9301, THERE IS ONE, OR FIRST PROCESSOR IN SERIES/1; AND IF 93BB
IS 9302, THIS IS THE SECOND PRIORITY PROCESSOR IN SERIES/1; AND IF 93 BB IS
9303, THIS IS THE THIRD PRIORITY PROCESSOR IN SERIES/1; AND SO ON.

2. SYSTEM MLC DEFINITIONS:

NOTE: 7900 TWO CHANNEL SWITCH
93BB PRIORITY OF SEQUENCE NUMBER OF PROCESSOR
9450 A COMMON I/O EXPANSION UNIT, BOTH WITHOUT TCS

I/O EXPANSION UNIT.

IF 7900 NOT PRESENT
IF 93BB NOT PRESENT
IF 9450 NOT PRESENT
NORMAL EXPANSION I/O CARD FILE

IF 7900 NOT PRESENT
IF 9450 NOT PRESENT
IF 93BB PRESENT
IS EXPANSION FOR PROCESSOR WITH 93 BB

IF 7900 NOT PRESENT
IF 9450 PRESENT
IF 93BB, 93BB PRESENT (OPTIONAL)
IS A COMMON EXPANSION BOX AFTER TCS FOR
PROCESSOR INDICATED WITH 93 BB (OPTIONAL)

- B) WHEN A PROCESSOR IS ASSOCIATED WITH ADDITIONAL I/O EXPANSION UNITS IN A CHAIN OF I/O EXPANSION UNITS, THE D/C 7900 INTERFACE CABLING COMES FROM THE LAST PRIVATE I/O EXPANSION UNIT IN THE CHAIN. HOWEVER, THE POR CABLE MUST GO TO THE PROCESSOR DRIVING THAT CHAIN. (A PRIVATE IS ONE WHICH IS NOT SHARED BETWEEN TWO PROCESSORS VIA D/C 7900, BUT IS A PRIVATE TO THE PROCESSOR AT THE BEGINNING OF THE CHANNEL ONLY).

- C) PROCESSORS MUST BE WITHIN TWO "WIRE" METERS OF THE I/O EXPANSION UNIT WITH D/C 7900. D/C 7900 FEATURE ATTACHMENT CARD RESIDES IN THE "A" SOCKET OF AN I/O EXPANSION UNIT.

- D) D/C 7900 CONNECTS TO THE PROCESSORS OR THE LAST PRIVATE I/O EXPANSION UNIT AT THE FOLLOWING LOCATIONS:

1. THE REPOWER CARD (D/C 1565) THAT IS RIGHT JUSTIFIED IN THE PROCESSOR.

ENG. CHANGE NO. 323200 327517 327517B
DATE OF CHANGE 23NOV81 08JAN82 12MAR82

2. "A" SOCKET IF NO D/C 1565 (4955 PROCESSOR).
 3. "B" THE REPOWER CARD (D/C 1565) THAT IS RIGHT JUSTIFIED IN AN I/O EXPANSION UNIT THAT IS THE LAST IN A CHAIN OF PRIVATE I/O EXPANSION UNITS ON A CHANNEL.
- E) D/C 7900 ONLY SUPPORTS TWO PROCESSORS.
- F) THE P.O.R. CABLE PLUGGED INTO THE "A" CONNECTOR AT THE CONSOLE, AND THE FLAT INTERFACE CABLE PLUGGED INTO "A" ROW OF THE D/C 7900 FEATURE CARD MUST GO TO THE SAME PROCESSOR. THIS PROCESSOR IS THEN "A" PROCESSOR. SEE LOGIC PAGE SW140.
- G) IT DOES NOT MATTER WHICH PROCESSOR IS "A" OR "B" PROCESSOR, ONLY THAT "F" ABOVE IS FOLLOWED.
- H) INSTALL FEATURE AND ADDRESS DEVICE JUMPERS PER LOGIC PAGE SW140. USE JUMPER P/N 4420751.

C.1 THE FOLLOWING ARE THE SUPPORTED CONFIGURATIONS FOR D/C 7900.

NOTE: FOR DETAILED PLUGGING LOCATIONS, LABEL INFORMATION AND POSSIBLE REWORK REQUIRED ON OLDER MODEL 4953'S AND 4955'S REFER TO STEP C.2.

- A) SUPPORTED 'Y' CONFIGURATIONS: - SEE FIGURE 3.
NOTE: THERE SHOULD BE THE FOLLOWING PRESENT -

NOTE - THE 'X' REPRESENTS ANY PROCESSOR

495X	495X
9202	9202
9301	9302

(BOTH OPTIONAL)
(PRIV) 9301

I/O EXPANSION UNIT (BOTH OPTIONAL)
9302

I/O EXPANSION UNIT
I/O EXPANSION UNIT (BOTH OPTIONAL) (COMMON #1)
9301
9302
9450
I/O EXPANSION UNIT (BOTH OPTIONAL) (COMMON #2)
9301
9302
9450
I/O EXPANSION UNIT (BOTH OPTIONAL) (COMMON #3)
9301
9302
9450

1. DETERMINE QUANTITY OF UNITS (3, 4, 5, OR 6).
2. FOR 3 UNITS, CHECK FOR PROCESSOR A TO HAVE 93 BB AND PROCESSOR B TO HAVE 93 BB. CHECK FOR I/O EXPANSION UNIT WITH 7900 TO HAVE 93 BB, 93 BB TO AGREE WITH ABOVE.
3. IF 2 BAY, GO TO #5; IF 3 BAY GO TO #6; IF ONE BAY PUT PROCESSOR "A" IN LOCATION X12, I/O EXPANSION UNIT IN LOCATION X34, AND PROCESSOR "B" IN LOCATION X56. (SEE CHART 4 FOR CODE IDENTIFICATION.)
4. USE THE TWO CABLE GROUPS (3') 4413776 TO GO FROM THE TCS CARD TO EACH PROCESSOR.

NOTE: IF PROCESSOR IS NOT 4955, PLUG PROCESSOR END OF CABLE ONTO A CHANNEL REPOWER CARD THAT IS RIGHT JUSTIFIED.
5. FOR TWO BAYS, PUT PROCESSOR A IN LOCATION 112, PROCESSOR B IN LOCATION 212, AND THE AN I/O EXPANSION UNIT IN LOCATION 134, (WHEN THE 2 BAYS ARE ADJACENT). (SEE CHART 4 FOR CODE IDENTIFICATION).
 - A. USE CABLE GROUP 4413776 (3') TO GO FROM TCS CARD ROW A TO PROCESSOR A. (SEE NOTE IN 4).
 - B. USE CABLE GROUP 4413777 (6') TO GO FROM TSC CARD ROW B TO PROCESSOR B. (SEE NOTE IN 4).
6. FOR 3 BAYS, PUT PROCESSOR A IN 312, AN I/O EXPANSION UNIT IN 112, PROCESSOR B IN 212, (WHEN THE 3 BAYS ARE ADJACENT) (SEE CHART 4 FOR CODE IDENTIFICATION).
 - A. USE TWO CABLE GROUPS 4413777 (6') TO GO FROM TSC CARD ROWS A AND B TO PROCESSOR A AND B RESPECTIVELY. (SEE NOTE IN 4).
 - B. IF 4 UNITS, CHECK THAT AN I/O EXPANSION UNIT WITHOUT 7900 HAS BOTH A PAIR OF 93 BB NUMBERS AND A 9450, SPECIFY CODE.

ENG. CHANGE NO. 323200 327517 327517B
DATE OF CHANGE 23NOV81 08JAN82 12MAR82

- B) SUPPORTED 'QUAD' CONFIGURATIONS - SEE FIG. 3.
NOTE: THERE WOULD BE THE FOLLOWING PRESENT -
- | I/O EXPANSION UNIT (BOTH OPTIONAL) | I/O EXPANSION UNIT (BOTH OPTIONAL) |
|------------------------------------|------------------------------------|
| 9301 | 9302 |
| I/O EXPANSION UNIT | I/O EXPANSION UNIT |
| 7900 | 7900 |
| 9301 | 9301 |
| 9302 | 9302 |
1. DETERMINE QUANTITY OF UNITS (4, 5, OR 6).
 2. FOR 4 UNITS, CHECK FOR 2 PROCESSORS AND TWO I/O EXPANSION UNITS WITH TCS 7900 IN EACH I/O EXPANSION UNIT.
 3. IF ONE BAY, PLACE PROCESSOR A IN 112, PROCESSOR B IN 178, AND PLACE THE TWO I/O EXPANSION UNITS IN 134, AND 156 RESPECTIVELY. (SEE CHART 4 FOR CODE IDENTIFICATION).
 - A. USE CABLE GROUP 4413776 TO GC FROM I/O EXPANSION UNIT 134, TCS CARD ROW A TO PROCESSOR A IN LOC 112.
 - B. USE CABLE GROUP 4413776 TO GC FROM I/O EXPANSION UNIT 156, TCS CARD ROW B TO PROCESSOR B IN LOC 178.
 - C. USE CABLE GROUP 4413776 TO GC FROM I/O EXPANSION UNIT 134, TCS CARD ROW B TO I/O EXPANSION UNIT IN LOC 156.
 - D. USE CABLE GROUP 4413776 TO GC FROM THE I/O EXPANSION UNIT IN LOC 156 TCS CARD ROW A TO THE I/O EXPANSION UNIT IN LOC 134.
 4. IF TWO BAYS, PLACE PROCESSOR A IN 112, PROCESSOR B IN 212, AND THE TWO I/O EXPANSION UNITS IN 134 AND 234 RESPECTIVELY. (SEE CHART 4 FOR CODE IDENTIFICATION).
 - A. USE CABLE GROUP 4413776 TO GO FROM THE I/O EXPANSION UNIT IN LOC 134, TCS CARD ROW A TO PROCESSOR A IN LOC 112.
 - B. USE CABLE GROUP 4413776 TO GC FROM THE I/O EXPANSION UNIT IN LOC 234, TCS CARD ROW B TO PROCESSOR B IN LOC 212.
 - C. USE CABLE GROUP 4413777 TO GO FROM THE I/O EXPANSION UNIT IN LOC 134, TCS CARD ROW B TO THE I/O EXPANSION UNIT IN LOC 234.
 - D. USE CABLE GROUP 4413777 TO GC FROM THE I/O EXPANSION UNIT IN LOC 234, TCS CARD ROW A TO THE I/O EXPANSION UNIT IN LOC 134.
 5. FOR 5 UNITS, CHECK FOR TWO PROCESSORS AND THREE I/O EXPANSION UNITS, TWO OF WHICH WILL CONTAIN TCS 7900 IN EACH I/O EXPANSION UNIT.
 6. IF TWO BAYS, PLACE PROCESSOR A IN 156, PROCESSOR B IN 234, AND TWO I/O EXPANSION UNITS WITH TCS 7900 IN 112.
 - A. USE CABLE GROUP 4413776 TO GC FROM THE I/O EXPANSION UNIT IN LOC 112, TCS CARD ROW A TO THE I/O EXPANSION UNIT IN LOC 234.
 - B. USE CABLE GROUP 4413776 TO GO FROM THE I/O EXPANSION UNIT IN LOC 212, TCS CARD ROW B TO PROCESSOR B IN LOC 234.
 - C. USE CABLE GROUP 4413777 TO GC FROM THE I/O EXPANSION UNIT IN LOC 112, TCS CARD ROW B TO THE I/O EXPANSION UNIT IN LOC 212.
 - D. USE CABLE GROUP 4413777 TO GO FROM THE I/O EXPANSION UNIT IN LOC 212, TCS CARD ROW A TO THE I/O EXPANSION UNIT IN LOC 112.
 - E. USE STANDARD I/O CABLES TO GC FROM THE I/O EXPANSION UNIT IN LOC 134 TO PROCESSOR IN THE I/O EXPANSION UNIT LOCATION 156.
 7. FOR 6 UNITS, CHECK FOR TWO PROCESSORS AND FOUR I/O EXPANSION UNITS, TWO I/O EXPANSION UNITS WILL EACH CONTAIN TCS 7900.
 8. IF TWO BAYS, PLACE PROCESSOR A IN 112, PROCESSOR B IN 212, AND TWO I/O EXPANSION UNITS WITH TCS 7900 IN 156 AND 256 RESPECTIVELY. AND THE I/O EXPANSION UNITS WITHOUT TCS 7900 IN 134 AND 234. RESPECTIVELY. (SEE CHART 4 FOR CODE IDENTIFICATION).
 - A. USE CABLE GROUP 4413776 TO GO FROM THE I/O EXPANSION UNIT IN LOC 156, TCS CARD ROW A TO THE I/O EXPANSION UNIT IN LOC 134.
 - B. USE CABLE GROUP 4413776 TO GC FROM THE I/O EXPANSION UNIT IN LOC 256, TCS CARD ROW B TO THE I/O EXPANSION UNIT IN LOC 234.
 - C. USE CABLE GROUP 4413777 TO GO FROM THE I/O EXPANSION UNIT IN LOC 156, TCS CARD ROW B TO THE I/O EXPANSION UNIT IN LOC 256.

ENG. CHANGE NO. 323200 327517 327517B
DATE OF CHANGE 23NOV81 08JAN82 12MAR82

- D. USE CABLE GROUP 4413777 TO GC FROM THE I/O EXPANSION UNIT IN LOC 256, TCS CARD ROW A TO THE I/O EXPANSION UNIT IN LOC 156.
- E. USE STANDARD I/O CABLES TO GO FROM THE I/O EXPANSION UNIT IN LOC 134 TO PROCESSOR A IN LCC 112.
- F. USE STANDARD I/O CABLES TO GC FROM THE I/O EXPANSION UNIT IN LOC 234 TO PROCESSOR B IN LCC 212.

C.2 CABLE PLUGGING, LABEL, POSSIBLE REWORK INFORMATION.

- A) FLAT INTERFACE CABLES WILL BE FOUND (ON MULTI-RACK SYSTEMS AND INDEPENDENT I/O EXPANSION UNITS ONLY). THERE IS AN EXISTING LABEL AT THE CONNECTOR END OF SEQUENCE 001 CABLE. THIS LABEL WILL BE MARKED WITH EITHER AN "A" OR A "B".

CHECK CHART 4 AND BELOW THE "A" OR "B" THAT IS WRITTEN ON THE LABEL, ADD THE PROCESSOR LOCATION IN A THREE DIGIT CODE AS SHOWN ON CHART 4.

INSTALL THESE I/O INTERFACE CABLES IN THE PROCESSOR OR THE LAST PRIVATE I/O EXPANSION UNIT IN THE FOLLOWING MANNER:

NOTE: IF A 4952B (S/N 15401 AND ABOVE), 4954B OR A 4955F PROCESSOR IS MOUNTED DIRECTLY BELOW A 4959 I/O EXPANSION UNIT, AND D/C 7900 IS BEING INSTALLED ON THE 4959 WITH SUPPORT TO THIS PROCESSOR, IT MAY BE NECESSARY TO FOLD THE I/O INTERCONNECTING CABLES OTHER THAN ON THE INDICATED FOLD MARKS FOR THEM TO REACH AND FIT PROPERLY IN THE PROCESSOR.

THE SEQ 001-W (A2) LABELED CABLE GOES TO THE TOP CARD SOCKET; SEQ 002-X (A3) LABELED CABLE GOES TO THE SECOND FROM THE TOP SOCKET; SEQ 003-Y (A4) LABELED CABLE GOES TO THE THIRD FROM THE TOP SOCKET AND SEQ. 004-Z (A5) LABELED CABLE GOES TO THE BOTTOM SOCKET. THIS IS FOR THE CARD OR BOARD LOCATIONS OF THE PROCESSOR OR LAST PRIVATE I/O EXPANSION UNIT. THE I/O EXPANSION UNIT (WITH D/C 7900) CABLE END WILL BE NUMBERED. #1 CABLE WILL GO TO THE TOP SOCKET ON D/C 7900 CARD.

- B) THE P.O.R. CABLES MUST BE ROUTED TO THE PIN SIDE OF THE BACK BOARD AS SHOWN IN FIGURES 1, 2, 3.

NOTE: IF PROCESSOR "A" OR "B" IS THE LAST PRIVATE I/O EXPANSION UNIT, THE P.O.R. CABLE MUST GO TO THE PROCESSOR DRIVING THAT CHANNEL. IT MUST ALSO BE WITHIN TWO "WIRE" METERS OF THE I/O EXPANSION UNIT WITH D/C 7900.

1. IF AN OLDER MACHINE IS ENCOUNTERED, THEN THE REAR COVER WILL HAVE TO BE NOTCHED AS SHOWN IN FIGURES 1 AND 2. AFTER REMOVING THE REAR COVER DO THIS IF REQUIRED.
2. ON THE PIN END OF THE P.O.R. CABLE, THREE LABELS WILL BE FOUND. EITHER AN "A" OR "B" WILL BE MARKED ON THE ONE ATTACHED TO THE CABLE JACKET. REMEMBER, IF THE CABLE IS PLUGGED INTO THE "A" CONNECTOR AT THE CONSOLE, IT MUST BE LABELED "A" AT THE PROCESSOR END AND THAT PROCESSOR IS THE "A" PROCESSOR.
3. ON EACH LEAD THAT PLUGS TO THE PINS WILL BE FOUND ANOTHER LABEL. ON THIS LABEL, WRITE THE APPROPRIATE PIN INFORMATION AS SHOWN BELOW:

FOR SINGLE CARD PROCESSORS: WRITE THE FOLLOWING PIN INFORMATION:

FOR P.O. R. SIGNAL CABLE (RED WIRE) WRITE F2-S05 (FOR HALF WIDE UNITS)
Q2-S05 (FOR FULL WIDE UNITS).

FOR GROUND (YELLOW WIRE) WRITE F2-U08 (FOR THE HALF WIDE UNITS)
Q2-U08 (FOR THE FULL WIDE UNITS).

4955: WRITE THE FOLLOWING PIN INFORMATION:

FOR P.O.R. SIGNAL CABLE (RED WIRE) WRITE Q2-M04.

FOR GROUND (YELLOW WIRE) WRITE Q2-P08.

4. NOW PLUG THE P.O.R. CABLE ONTO THE APPROPRIATE PINS.

REINSTALL BOARD COVER.

C.3 EXPLANATION OF THE REMAINING HARDWARE. (SUPPLIED ON B/M 6826831).

SUPPLIED SEPARATELY IS A CONNECTOR HOUSING (P/N 1847524) AND TWO (2) PINS (P/N 1847520). THESE PARTS ARE SUPPLIED SO THAT THE CUSTOMER CAN MAKE HIS ALARM, AUDIO OR WHATEVER, TO LET HIM KNOW WHEN A PROCESSOR IS DOWN. THIS ALARM AND CABLE ARE THE CUSTOMERS RESPONSIBILITY. THE PARTS ARE SUPPLIED SO THAT HE CAN MAKE HIS ALARM AND PLUG IT INTO THE "C" CONNECTOR ON THE D/C 7900 CONSOLE CARD.

EXPLAIN THIS TO THE CUSTOMER AND HAND HIM THE HARDWARE.

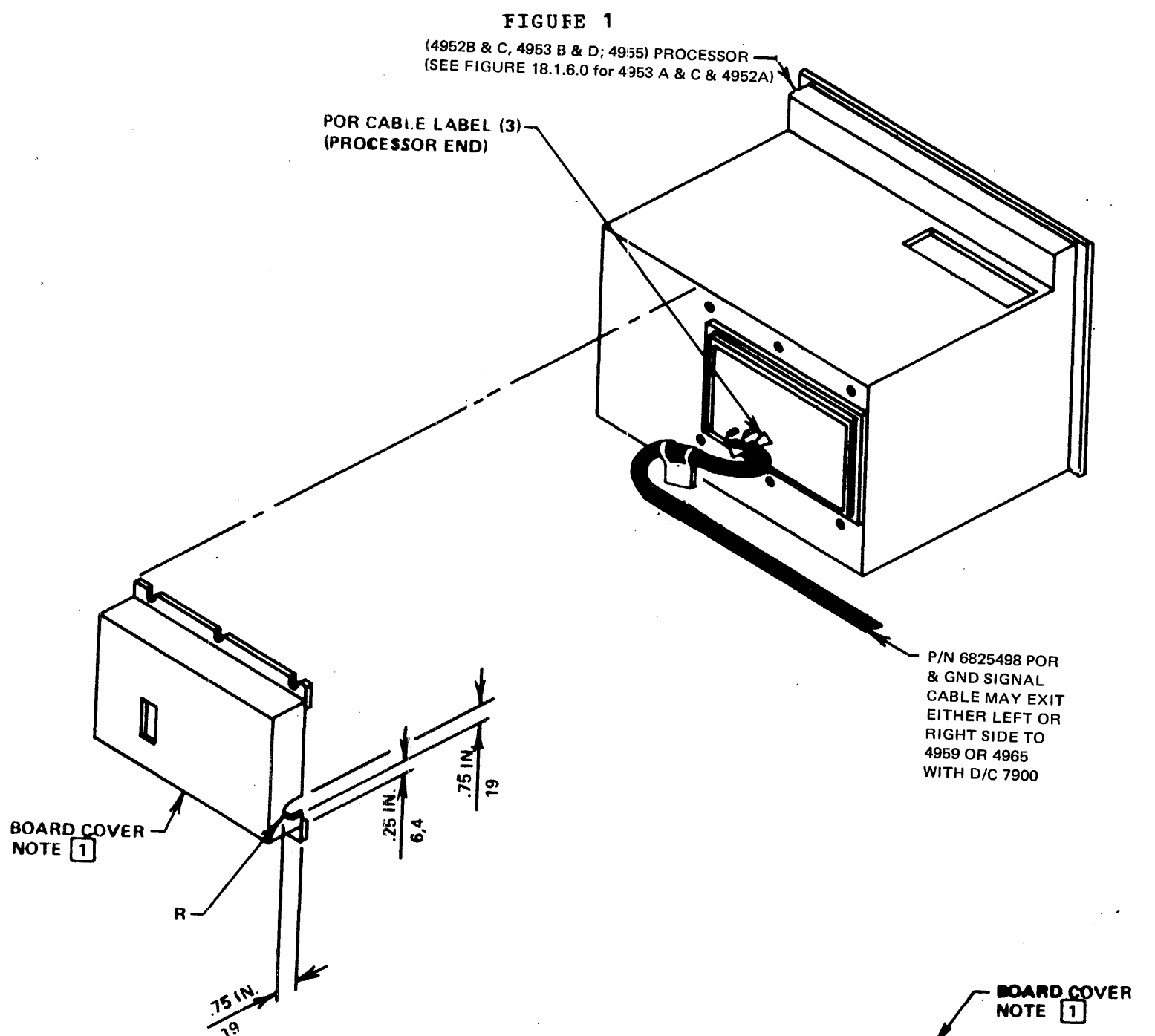

NOTE 1: DIMENSIONED SLOT MUST BE CUT OUT ON OLDER MACHINES.
 CUT OUT ON LEFT OR RIGHT SIDE DEPENDING ON POR SIGNAL
 CABLE ROUTING.

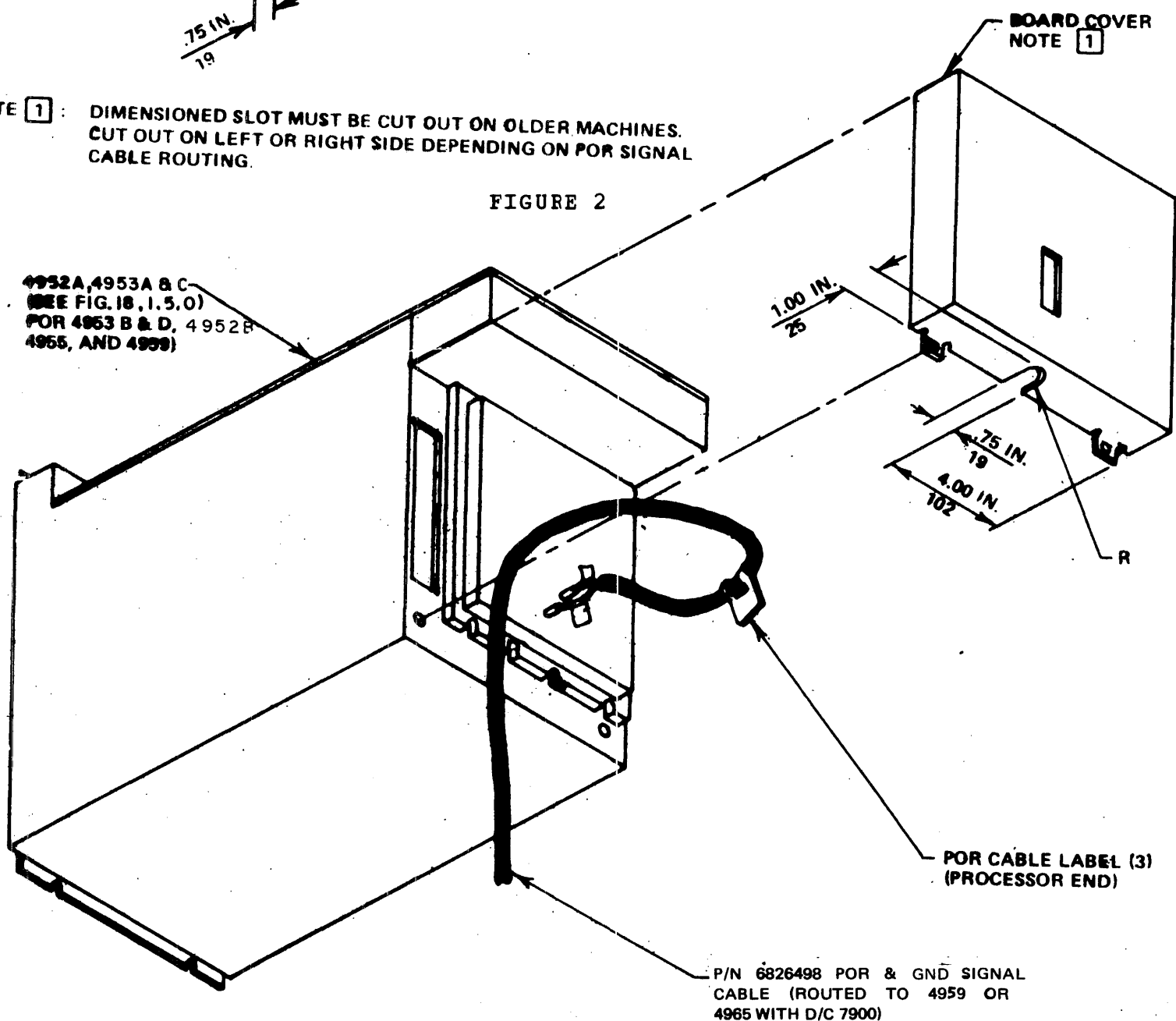

NOTE:
 1 SLOT DIMENSIONED ON BOARD COVER
 WILL HAVE TO BE CUT OUT ON OLDER
 MACHINES.

ENG. CHANGE NO. 323200 327517 327517B
 DATE OF CHANGE 23NOV81 08JAN82 12MAR82

FIGURE 3

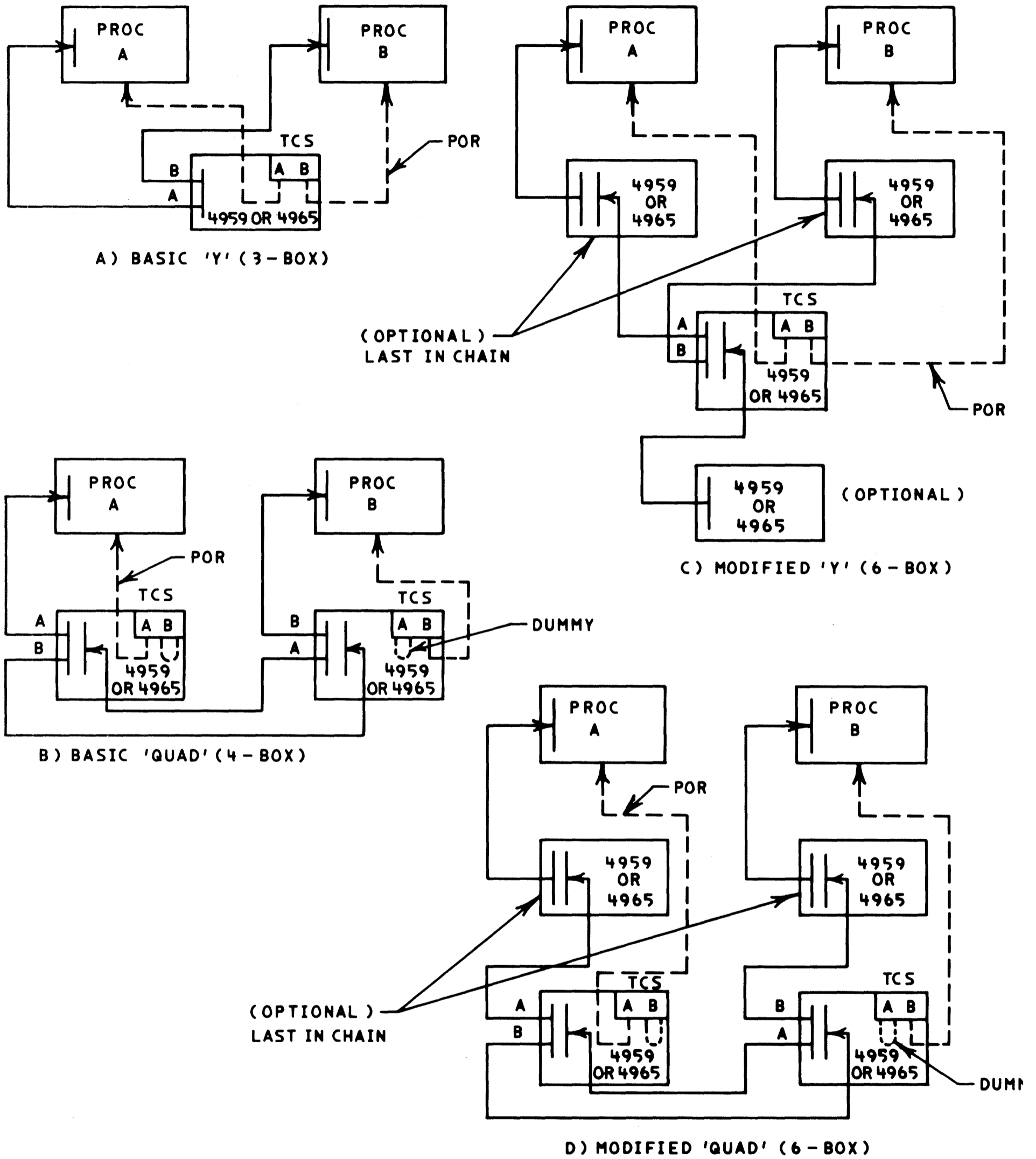

TCS SUPPORTED CONFIGURATIONS

ENG. CHANGE NO. 323200 327517 327517B
 DATE OF CHANGE 23NOV81 08JAN82 12MAR82

C.4 RACK ENCLOSURE LOCATIONS

CHART 4 SHOWS HOW THE 1.8 METRE AND THE 1.0 METRE RACK ENCLOSURE LOCATIONS ARE NUMBERED.

A LOCATION IS EXPRESSED AS A THREE DIGIT NUMBER. THE FIRST DIGIT IS THE BAY NUMBER. THE SECOND DIGIT IS EITHER THE LEFTHAND LOCATION, IF USED, OR A ZERO IF NOT USED FOR THIS UNIT, AND A THIRD DIGIT IS THE RIGHTHAND LOCATION, IF USED, OR A ZERO IF NOT USED FOR THIS UNIT.

FOR EXAMPLE: A 4955 PROCESSOR (A) MOUNTED IN THE FIRST BAY OF A 1.8 METRE MULTIPLE BAY ENCLOSURE WOULD NORMALLY BE ASSIGNED 134. THE 1 INDICATING BAY 1, THE 3 INDICATING THAT THE LEFTHAND HALF UNIT LOCATION AND THE 4 THAT THE RIGHTHAND UNIT LOCATIONS WERE BEING USED.

SIMILARLY, A 150 FOR A 4999 BATTERY BACKUP UNIT (B) WOULD USE THE 5 SPACE IN THE FIRST BAY IMMEDIATELY UNDER THE PROCESSOR AND LEAVE THE RIGHTHAND OR 6 SPACE, OPEN FOR SOME OTHER HALF-WIDTH UNIT LIKE A 4964 DISKETTE UNIT OR A 4982 SENSOR I/O UNIT.

*NOTE: A BAY IS A RACK

1.8 METRE ENCLOSURES (4997-2)

BAY 4		BAY 2		BAY 1		BAY 3		BAY 5	
1	2	1	2	1	2	1	2	1	2
3	4	3	4	3	4	3	4	3	4
5	6	5	6	5	6	5	6	5	6
7	8	7	8	7	8	7	8	7	8

1.0 METRE ENCLOSURES (4997-1)

BAY 4		BAY 2		BAY 1		BAY 3		BAY 5	
1	2	1	2	1	2	1	2	1	2
7	8	7	8	7	8	7	8	7	8

CHART 4

ENG. CHANGE NO. 323200 327517 327517B
DATE OF CHANGE 23NOV81 08JAN82 12MAR82

APPENDIX D

WORLD TRADE POWER CONSIDERATIONS

FOR JAPAN ONLY:

SINCE JAPAN CANNOT HAVE GROUND CONDUCTOR LEAKAGE CURRENT IN EXCESS OF 3.5 MILLIAMPS, ALL 4997 ENCLOSURES INSTALLED IN JAPAN WILL HAVE A COMPENSATION NETWORK INSTALLED. THE COMPENSATION NETWORK IS MOUNTED ON THE RIGHT, REAR RAIL, ABOVE THE POWER DISTRIBUTION. THE PURPOSE OF THE COMPENSATION NETWORK IS TO REDUCE THE GROUND CONDUCTOR LEAKAGE CURRENT BELOW 3.5 MA - IF REQUIRED.

THE GROUND CONDUCTOR LEAKAGE CURRENT MUST BE DETERMINED FOR SINGLE PHASE POWER WHERE NONE OF THE CURRENT CARRYING CONDUCTORS ARE AT GROUND POTENTIAL. TO DETERMINE IF THIS CONDITION EXISTS, USE A SIMPSON 260 METER, OR SIMILAR METER ($\pm 3\%$); AND CHECK THE PHASES AT THE SERVICE OUTLETS AS SHOWN IN FIGURE 1, TABLE "A".

- A) IF CONDITION "A" IS FOUND TO EXIST, CONTACT INSTALLATION PLANNING, AS AN IMPROPER POWER CONFIGURATION HAS BEEN PROVIDED FOR THE UNIT.
- B) IF CONDITION "B" IS FOUND TO EXIST, THE COMPENSATION NETWORK IS NOT NEEDED. INSURE THAT THE NETWORK IS NOT PLUGGED INTO THE RACK POWER DISTRIBUTION AND PROCEED WITH THE INSTALLATION. OMIT THE REST OF THIS SECTION.
- C) IF CONDITION "C" IS FOUND TO EXIST, THE COMPENSATION NETWORK MAY BE REQUIRED, AND THE LEAKAGE CURRENT FOR THE RACKS CONFIGURATION MUST BE DETERMINED.

REFER TO TABLE 3 AND DETERMINE THE LEAKAGE CURRENT BEFORE PROCEEDING.

NOTE: THE FOLLOWING STEPS ARE TO BE DONE ONLY IF THE TOTAL LEAKAGE CURRENT FOR THE RACK WAS DETERMINED TO BE BETWEEN 2.5 AND 5.0 MILLIAMPERES IN TABLE 3.

- A) LOCATE THE COMPENSATION NETWORK ASSEMBLY MOUNTED TO THE RIGHT REAR VERTICAL MEMBER OF THE RACK ABOVE THE POWER DISTRIBUTION.
- B) REMOVE THE THREE SCREWS (TWO ON THE BOTTOM AND ONE ON THE TOP MIDDLE OF THE COVER) AND REMOVE THE COVER. OBSERVE TB1 INSIDE THE COMPENSATION NETWORK ASSEMBLY. SEE FIGURE 2.
- C) NOTICE THAT THERE ARE TWO JUMPERS ON TB1. ONE CONNECTS TB1-2 TO TB1-3. THE OTHER CONNECTS TB1-3 TO TB1-4. REMOVE THE JUMPER BETWEEN TB1-2 AND TB1-3. REFER TO FIGURE 2.
- D) REASSEMBLE THE COMPENSATION NETWORK COVER TO THE ASSEMBLY, AND PLUG THE NETWORK INTO THE RACK POWER DISTRIBUTION.

PLUG THE UNITS MOUNTED IN THE RACK INTO THE POWER DISTRIBUTION AND CONTINUE WITH THE INSTALLATION IN SECTION 4.

ENG. CHANGE NO. 323200 327517 327517B
 DATE OF CHANGE 23NOV81 08JAN82 12MAR82

FIGURE 1

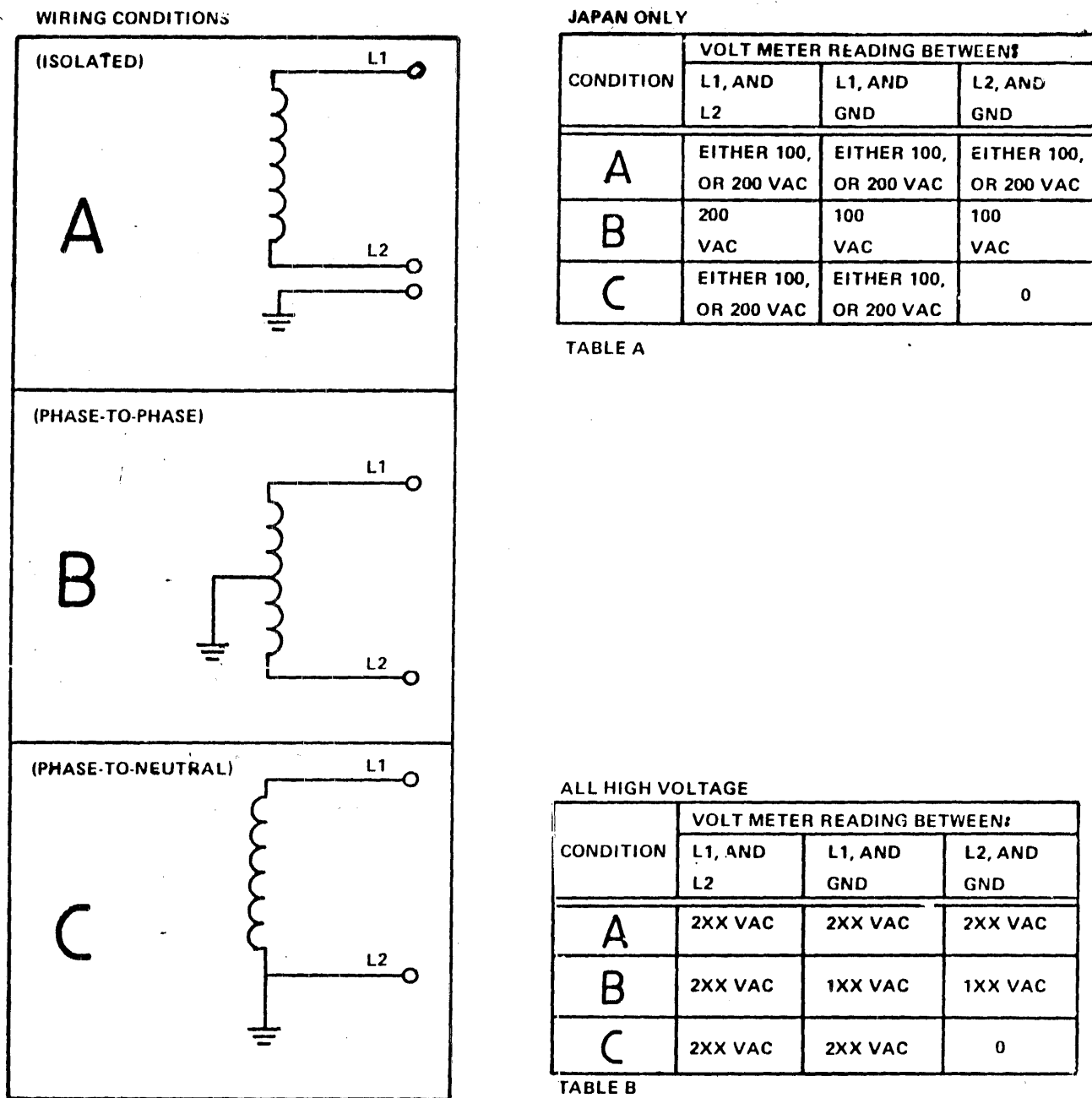
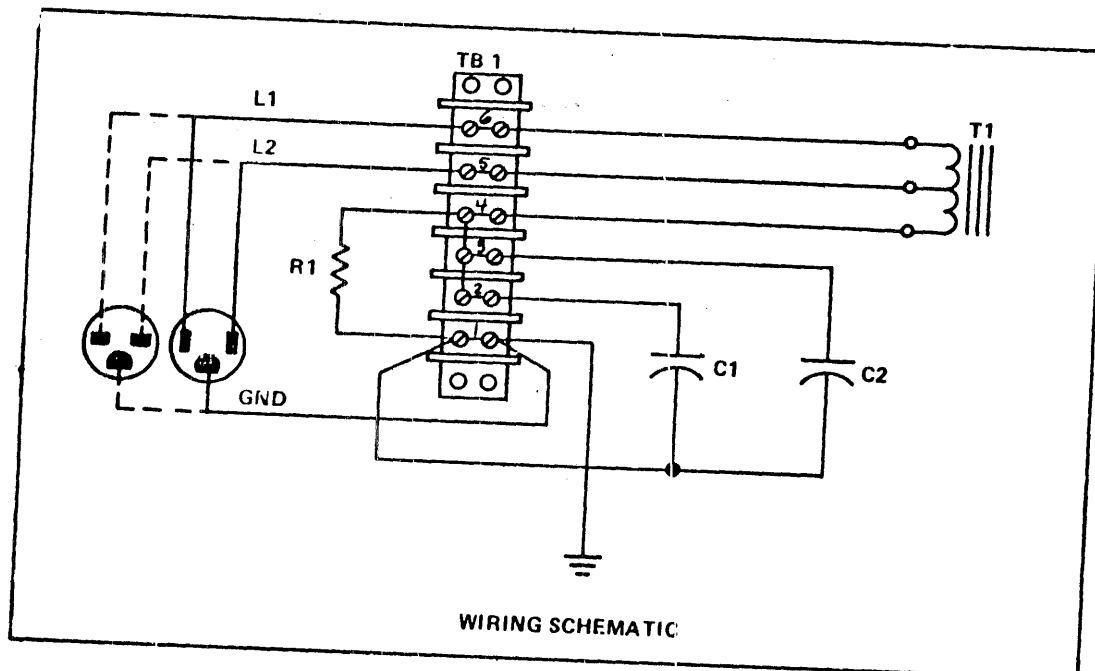
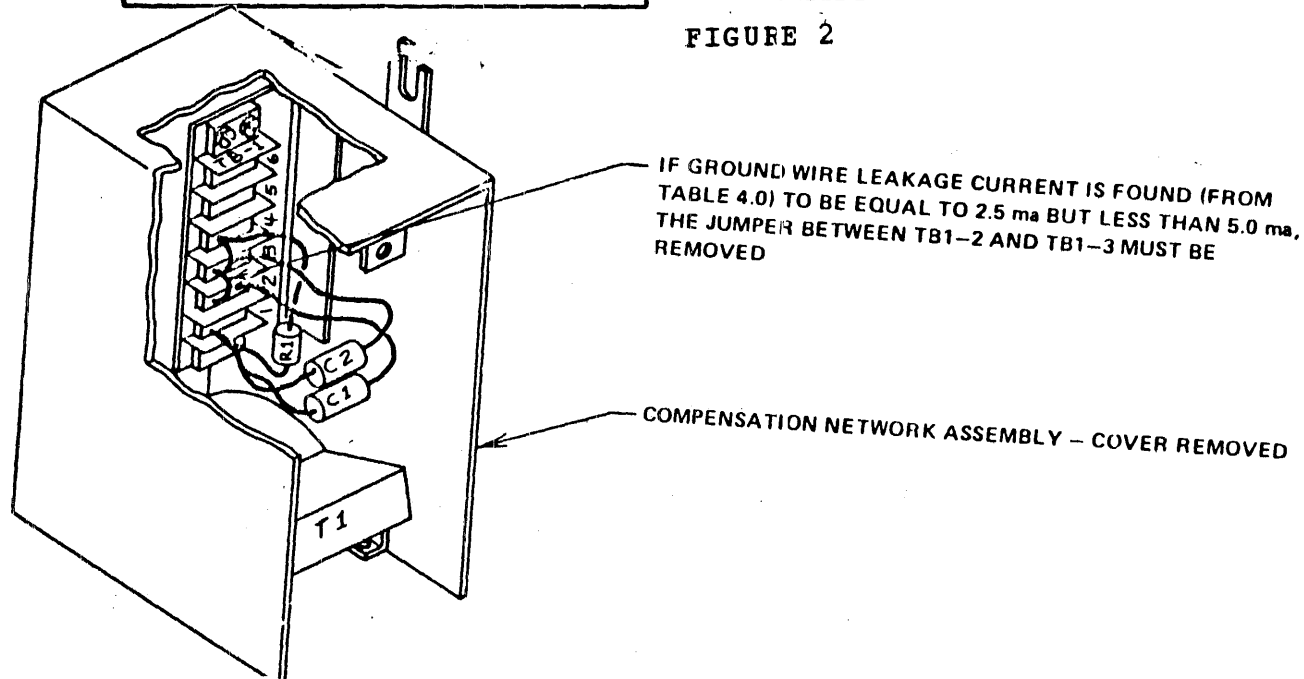

FIGURE 2



(JAPAN ONLY)

UNIT	LEAKAGE CURRENT (IN MILLIAMPS)	X	NUMBER OF UNITS	=	UNIT TOTALS
4952	0.4	X	_____	=	_____
4952B (S/N 15401 & ABOVE)	0.1	X	_____	=	_____
4952C	0.7	X	_____	=	_____
4953	1.2	X	_____	=	_____
4954A	.4	X	_____	=	_____
4954B	.01	X	_____	=	_____
4954C	.7	X	_____	=	_____
4955	1.2	X	_____	=	_____
4955F	.01	X	_____	=	_____
4959	1.0	X	_____	=	_____
4959 (S/N 22501 & ABOVE)	.01	X	_____	=	_____
4962	1.5	X	_____	=	_____
4963	2.0	X	_____	=	_____
4964	1.0	X	_____	=	_____
4965	0.7	X	_____	=	_____
4966	2.0	X	_____	=	_____
4969	3.0	X	_____	=	_____
4982	0.0	X	_____	=	_____
4987	1.0	X	_____	=	_____
4993	1.0	X	_____	=	_____
4999	0.0	X	_____	=	_____

TOTAL 4997 LEAKAGE CURRENT = _____
 (IN MILLIAMPS)

----- (JAPAN ONLY) -----

↓
 MILLIAMPS LESS THAN 2.5 MA:-----> COMPENSATION NETWORK IS NOT REQUIRED, PLUG UNITS INTO RACK POWER DISTRIBUTION AND PROCEED WITH INSTALLATION

↓
 MILLIAMPS EQUAL TO 2.5MA BUT LESS THAN 5.0 MA -----> COMPENSATION NETWORK IS REQUIRED AND MUST BE RECONFIGURED.

↓
 MILLIAMPS GREATER THAN 5.0MA:-----> COMPENSATION NETWORK IS REQUIRED, AND SHOULD BE PLUGGED INTO THE RACK POWER DISTRIBUTION, BEFORE PLUGGING THE UNITS INTO THE RACK.

EIA LEAKAGE CURRENT CHART

TABLE 3

ENG. CHANGE NO. 323200 327517 327517B
DATE OF CHANGE 23NOV81 08JAN82 12MAR82

125 WATT POWER SUPPLY (U.K. HIGH VOLTAGE ONLY) CONVERSION TO PHASE-TO-NEUTRAL POWER FROM PHASE-TO-PHASE WIRING (IF NOT FACTORY WIRED FOR U.K.). IF IN DOUBT AS TO CONFIGURATION, PROCEED AS FOLLOWS AND VERIFY.

THE CONVERSION WILL CONSIST OF CHANGING ONE LEAD ON TB1 INSIDE THE POWER SUPPLY. PROCEED AS FOLLOWS:

GAIN ACCESS TO THE POWER SUPPLY.

- A. REMOVE THE DECORATIVE FRONT COVER.
- B. OPEN THE CONSOLE GATE BY LOOSENING THE SCREW LOCATED AT THE TOP AND BOTTOM - CENTER OF THE CONSOLE GATE AND SWING THE GATE OPEN.
- C. REMOVE THE FRONT COVER MOUNTING BRACKET, LOCATED AT THE RIGHT FRONT CORNER OF THE 4953 A & C IN THE FRONT OF THE POWER SUPPLY, BY REMOVING THE TWO SCREWS.
- D. REMOVE THE BACK BOARD COVER BY REMOVING THE SCREWS LOCATED AT THE RIGHT AND LEFT LOWER REAR CORNERS OF THE UNIT.
- E. UNPLUG THE TWO TOP CABLES LOCATED AT THE TOP REAR OF THE POWER SUPPLY. REMOVE THE FOUR FLAT CABLES LOCATED AT THE LOWER SECTION OF THE POWER SUPPLY, BY REMOVING FOUR SCREWS.

NOTE: POWER SUPPLY, AT EC 578375 REWORK LEVEL, WILL HAVE TWO BLACK WIRES ATTACHED HERE ALSO. REMOVE THESE AND NOTE THEM AS TO LOCATION FOR ASSEMBLY.

- F. OBSERVE AND ABIDE BY ALL WARNING LABELS ON THE POWER SUPPLY.
- G. UNPLUG ALL CONNECTIONS ON THE FRONT OF THE POWER SUPPLY (J8, J9, AND 10).
- H. REMOVE THE POWER SUPPLY FROM THE UNIT BY REMOVING THE ONE SCREW LOCATED AT THE TOP OF THE POWER SUPPLY. CAREFULLY PULL THE SUPPLY OUT OF THE FRONT OF THE UNIT - BEING CAREFUL NOT TO DAMAGE THE CABLES.

GAIN ACCESS TO TB1.

- A. REMOVE THE SIX SCREWS HOLDING THE SIDE PLATE ASSEMBLY ON THE POWER SUPPLY. CAREFULLY REMOVE THE SIDE PLATE ASSEMBLY. SEE FIG. 4.
- B. REMOVE THE TERMINAL BLOCK SAFETY SHIELD AND OBSERVE TB1 AT THE TOP CENTER OF THE POWER SUPPLY.

REWIRE TB1 AS SHOWN ON FIGURE 5.

REASSEMBLE THE UNIT BY REVERSING PROCEDURES ABOVE. BE SURE ALL CONNECTIONS ARE SECURE AND WIRING IS ROUTED PROPERLY TO AVOID BEING PINCHED DURING ASSEMBLY.

ENG. CHANGE NO. 323200, 327517, 327517B
 DATE OF CHANGE 23NOV81, 08JAN82, 12MAR82

FIG. 4

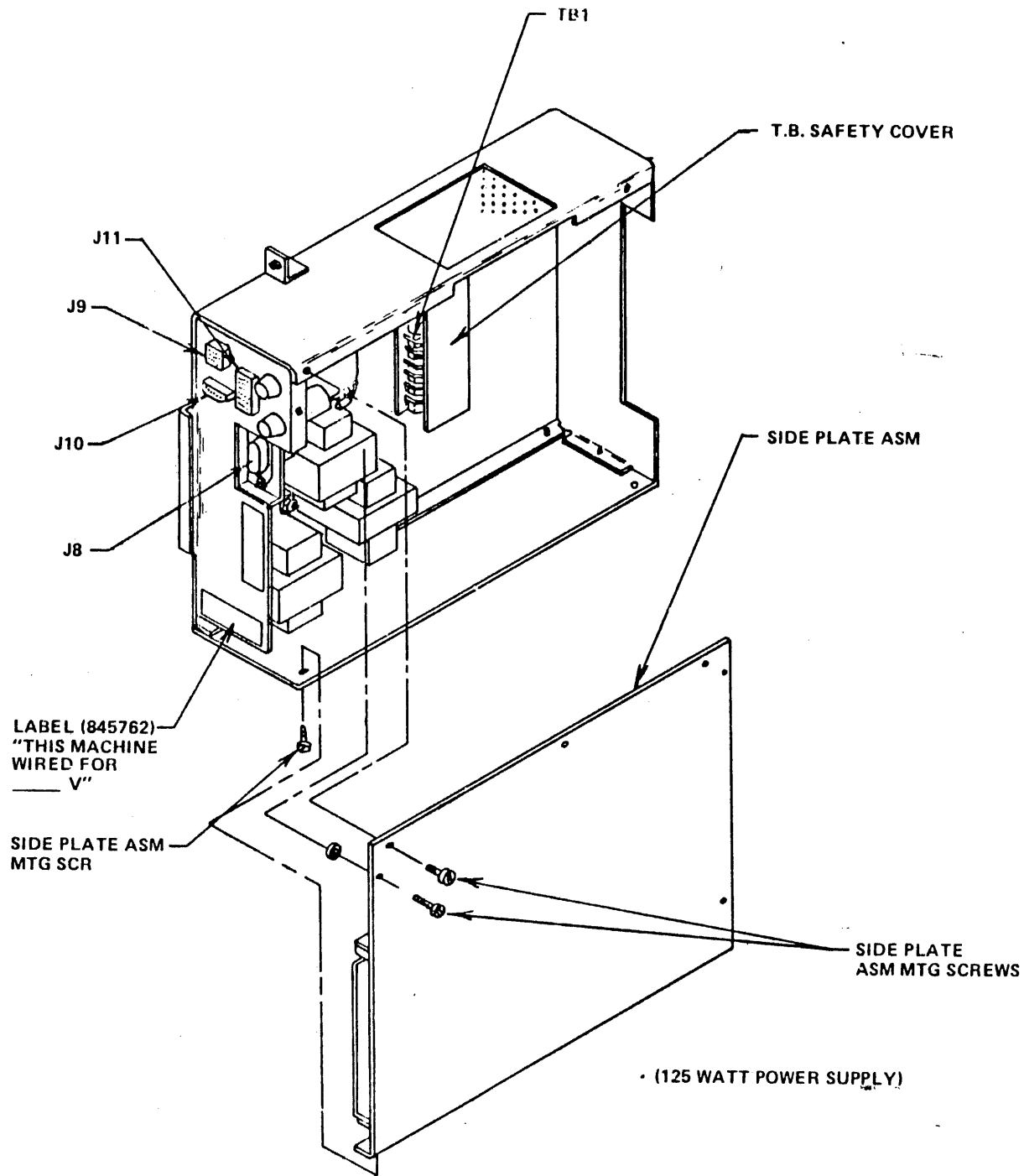
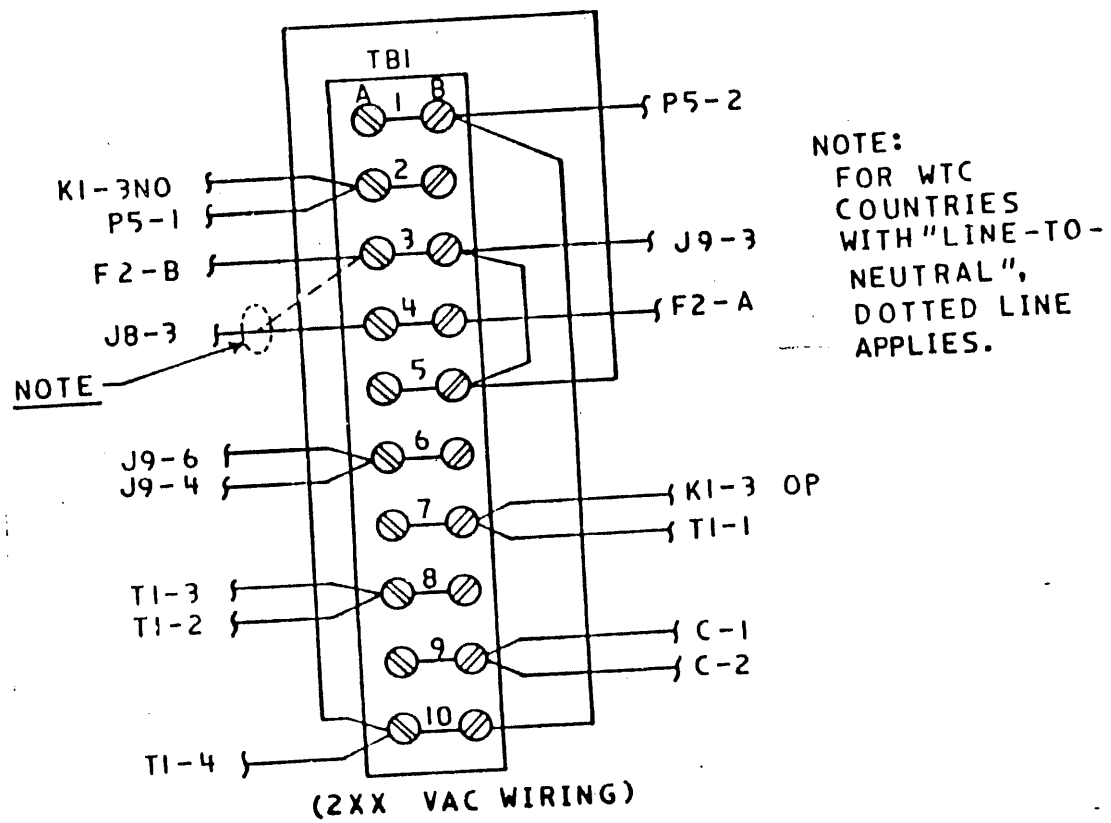

FIG. 5



ENG. CHANGE NO. 323200 327517 327517B
DATE OF CHANGE 23NOV81 08JAN82 12MAR82

300 WATT POWER SUPPLY (U.K. HIGH VOLTAGE ONLY) CONVERSION TO PHASE-TO-NEUTRAL POWER FROM PHASE-TO-PHASE WIRING (IF NOT FACTORY WIRED FOR U.K.) IF IN DOUBT AS TO CONFIGURATION, PROCEED AS FOLLOWS AND VERIFY. THE CONVERSION WILL CONSIST OF CHANGING ONE LEAD ON TB1 INSIDE THE POWER SUPPLY. PROCEED AS FOLLOWS:

GAIN ACCESS TO THE POWER SUPPLY.

- A. REMOVE THE DECORATIVE FRONT COVER.
- B. OPEN THE CONSOLE GATE BY LOOSENING THE SCREWS LOCATED ON THE RIGHT HAND SIDE OF THE CONSOLE GATE AND SWING THE GATE OPEN.
- C. OBSERVE AND ABIDE BY ALL WARNING LABELS ON THE POWER SUPPLY.
- D. REMOVE THE POWER CORD FROM THE FRONT OF THE POWER SUPPLY BY REMOVING THE TWO (2) THUMB SCREWS AND UNPLUGGING.

GAIN ACCESS TO TB1, SEE FIG. 6.

- A. REMOVE THE FOUR SCREWS HOLDING THE FRONT COVER ON THE POWER SUPPLY. CAREFULLY REMOVE THE FRONT COVER.
- B. REMOVE THE TERMINAL BLOCK SAFETY SHIELD AND OBSERVE TB1 AT THE TOP CENTER OF THE POWER SUPPLY.

REWIRE TB1 AS SHOWN ON FIGURE 7.

REASSEMBLE THE UNIT BY REVERSING PROCEDURES ABOVE. BE SURE ALL CONNECTIONS ARE SECURE AND WIRING IS ROUTED PROPERLY TO AVOID BEING PINCHED DURING ASSEMBLY.

ENG. CHANGE NO. 323200 327517 327517B
 DATE OF CHANGE 23NOV81 08JAN82 12MAR82

FIGURE 6

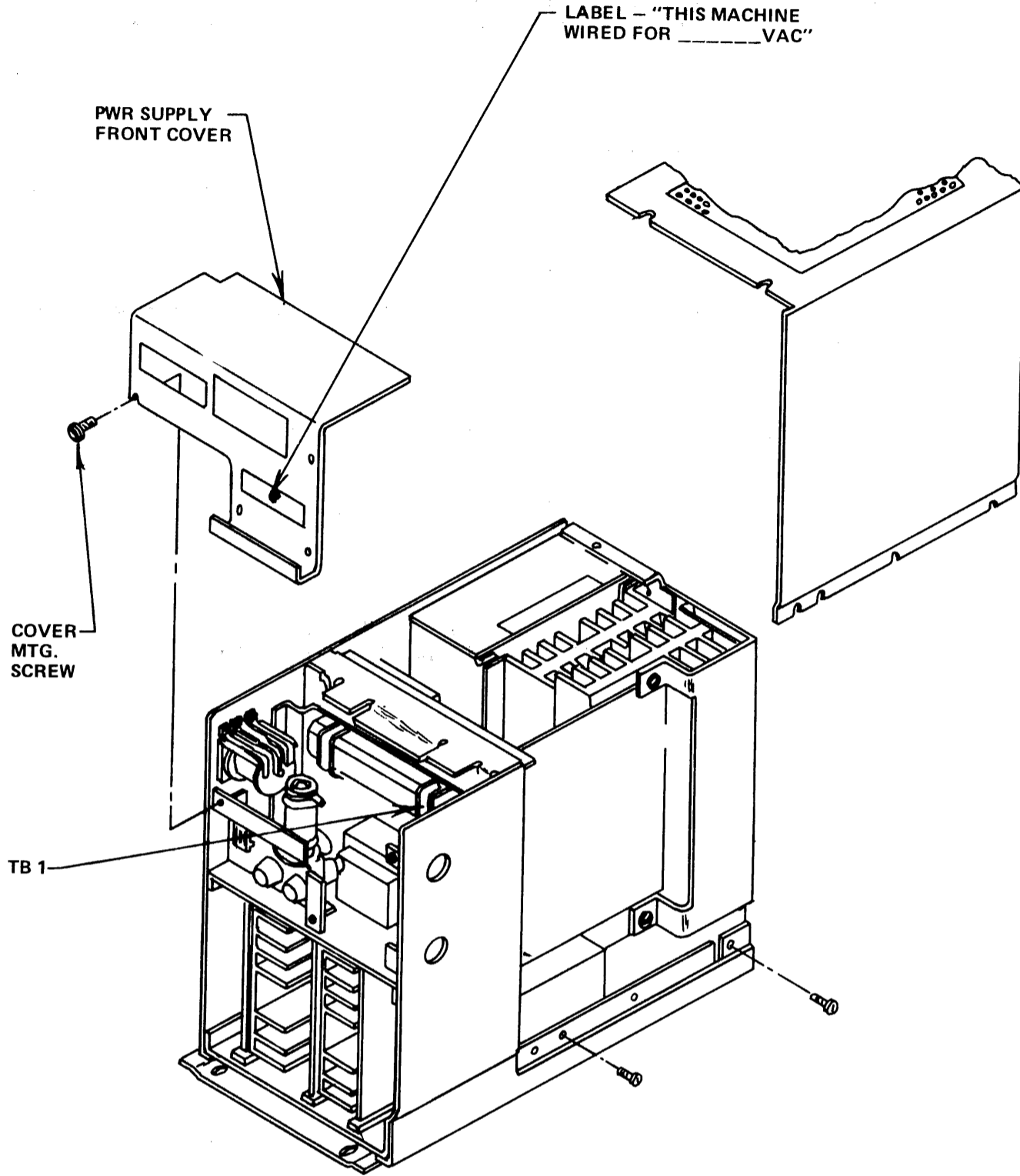

(PWR SUPPLY SHOWN REMOVED FROM UNIT, WITH SIDE COVER REMOVED FOR CLARITY)

FIGURE 7

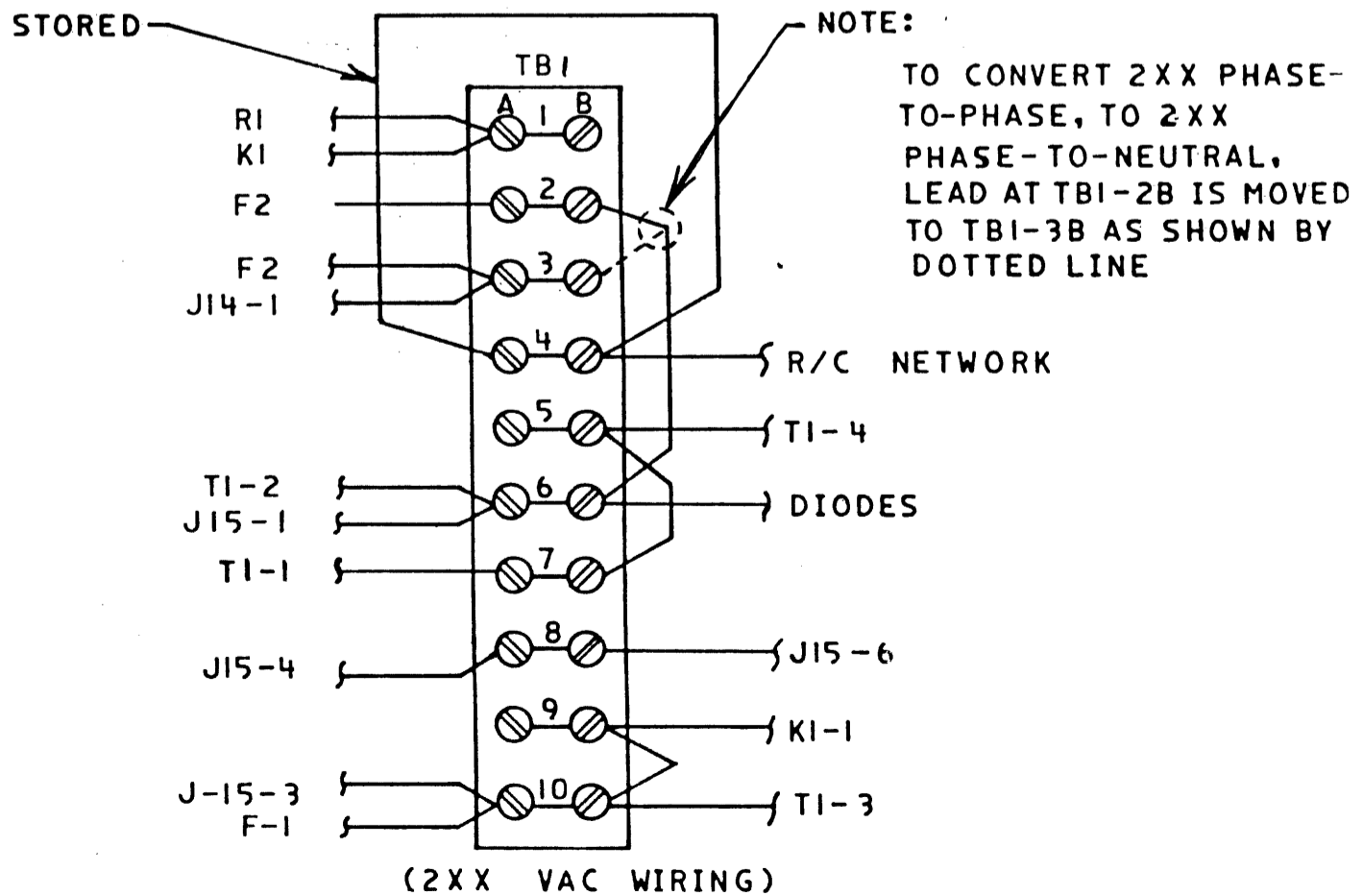

APPENDIX E

PROCESSOR/EXPANSION UNIT CABLING

THE PROCESSORS AND I/O EXPANSION UNITS ARE ATTACHED TO ONE ANOTHER VIA FOUR FLAT INTERFACE CABLES. THE CABLES EXIT THROUGH THE OPENING WITHIN THE UNIT AND ARE ROUTED VERTICALLY DOWN THROUGH A SIMILAR OPENING IN THE TOP OF THE UNIT.

NOTE: IF A 4952B (S/N 15401 & ABOVE), 4954B OR A 4955F PROCESSOR IS MOUNTED DIRECTLY BELOW 4959 I/O EXPANSION UNIT, IT MAY BE NECESSARY TO FOLD THE I/O INTERCONNECTING CABLES OTHER THAN ON THE INDICATED FOLD MARKS FOR THEM TO REACH AND FIT PROPERLY IN THE PROCESSOR.

IF UNITS ARE MOUNTED HORIZONTALLY ADJACENT IN A MULTIRACK CONFIGURATION, CABLES ENTER AND EXIT THE CARD FILE IN THE SAME METHOD AS IF VERTICAL TO ONE ANOTHER.

CABLES ARE RETAINED VIA THE CABLE CLAMP BRACKET WITHIN THE CARD FILE UNIT CHASSIS. IT IS IMPORTANT THAT THIS CLAMP BE CLOSED IN ORDER FOR THE SYSTEM COOLING TO FUNCTION PROPERLY. THE CLAMP IS CLOSED BY THE TIGHTENING OF THE TWO SCREWS AS SHOWN IN FIGURE 1.

THE TERM I/O EXPANSION UNIT DENOTES BOTH THE 4959 AND THE 4965. PROCEDURES FOR CABLING FEATURE CABLES INTO THE PROCESSOR OR I/O EXPANSION UNITS ARE AS FOLLOWS:

- A) REMOVE FRONT COVER AND REMOVE SCREWS WHICH FASTEN THE UNIT TO THE RACK. PULL THE UNIT OUT FROM THE RACK APPROXIMATELY 6 INCHES.

NOTE: W.T.C. COUNTRIES MUST ALSO REMOVE PLASTIC SAFETY SHIELD FOUND IN CARD FILE AREA. THE CONSOLE GATE MUST BE SWUNG OPEN ON SOME MODELS.

NOTE: PULL OUT UNIT DIRECTLY BELOW 4952A AND 4954A 6 INCHES TO ALLOW ACCESS TO BOTTOM MOUNTING SCREW.

WARNING: CARE MUST BE TAKEN TO AVOID DAMAGE TO THE I/O EXPANSION UNITS' INTERCONNECTING CABLES.

- B) ROUTE THE CABLES (FLAT OR ROUND) FROM THE MACHINE REAR TO FRONT.
- C) ROUTE THE CABLES INTO THE PROCESSOR OR I/O EXPANSION UNIT VIA THE LARGE OPENING ON TOP OF THE UNIT, INSERT CONNECTORS ONTO THE APPROPRIATE CARD AND TIGHTEN CABLE CLAMP BRACKET.
- D) GROUP CABLES TOGETHER AND INSERT CABLE CLAMP P/N 1634983 INTO THE TOP OF THE UNIT TO RETAIN THE CABLES.
- E) ATTACH THE CABLE SHIELD GROUND WIRE TO THE GROUND BUS LOCATED ON TOP OF THE PROCESSOR AND I/O EXPANSION UNIT. USE THE SCREW AND LOCKWASHER LOCATED THERE.
- NOTE: IF A GOOD ELECTRICAL GROUND CAN BE MADE BETWEEN THE CABLE SHIELD AND CLAMP IN STEP H, THIS STEP MAY BE OMITTED.
- F) PUSH THE UNIT INTO THE RACK AND FASTEN WITH THE SCREWS REMOVED IN STEP A). REPLACE SAFETY SHIELD IF APPLICABLE, CLOSE GATE IF APPLICABLE AND SNAP ON FRONT COVER.
- G) GROUP CABLES AT THE REAR OF THE UNIT AND PERFORM ITEM #D, ABOVE.
- H) CLAMP EACH EXTERNAL CABLE TO THE VERTICAL MOUNTING STRIP IN THE REAR OF THE RACK.
- I) FOR REMOVAL OF CABLES, PERFORM THE ABOVE STEPS IN REVERSE ORDER.

SERIES/1 SYSTEM
IBM INSTALLATION INSTRUCTION

AA100
P/N 1633743
PAGE 46 OF 48

ENG. CHANGE NO. 323200 327517 327517B
DATE OF CHANGE 23NOV81 08JAN82 12MAR82

PAGE LEFT INTENTIONALLY BLANK

Cut Along Line

READER'S COMMENT FORM

IBM Series/1
System Installation Instructions

P/N 1633743

Your comments assist us in improving the usefulness of our publications; they are an important part of the input used in preparing updates to the publications. All comments and suggestions become the property of IBM.

Please do not use this form for technical questions about the system or for requests for additional publications;

Corrections or clarifications needed:

EC Level Page Comment

Please indicate your name and address in the space below if you wish a reply.

Thank you for your cooperation. No postage stamp necessary if mailed in the U.S.A.

E/C 327517B
Page 47 of 48

READER'S COMMENT FORM

IBM Series/1
System Installation Instructions

P/N 1633743

Your comments assist us in improving the usefulness of our publications; they are an important part of the input used in preparing updates to the publications. All comments and suggestions become the property of IBM.

Please do not use this form for technical questions about the system or for requests for additional publications;

Corrections or clarifications needed:

EC Level Page Comment

Please indicate your name and address in the space below if you wish a reply.

Thank you for your cooperation. No postage stamp necessary if mailed in the U.S.A.

E/C 327517B
Page 47 of 48

Reader's Comment Form

Reader's Comment Form

Fold

Fold

Fold

Fold



NO POSTAGE
NECESSARY
IF MAILED
IN THE
UNITED STATES

BUSINESS REPLY MAIL
FIRST CLASS PERMIT NO. 40 ARMONK, NEW YORK
POSTAGE WILL BE PAID BY ADDRESSEE

IBM Corporation
CSD Service Planning and Support
Department 90B/Building 218
P.O. Box 1328
Boca Raton, Florida 33432



NO POSTAGE
NECESSARY
IF MAILED
IN THE
UNITED STATES

BUSINESS REPLY MAIL
FIRST CLASS PERMIT NO. 40 ARMONK, NEW YORK
POSTAGE WILL BE PAID BY ADDRESSEE

IBM Corporation
CSD Service Planning and Support
Department 90B/Building 218
P.O. Box 1328
Boca Raton, Florida 33432

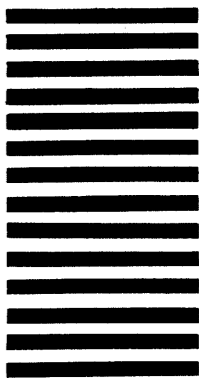

Fold

Fold

Fold

Fold



International Business Machines Corporation
Customer Service Division
400 Parsons Pond Drive
Franklin Lakes, NJ 07417
(U.S.A. only)
General Business Group/International
44 South Broadway
White Plains, NY 10601
U.S.A. (International)

E/C 327517 B
Page 48 of 48

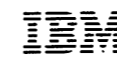

International Business Machines Corporation
Customer Service Division
400 Parsons Pond Drive
Franklin Lakes, NJ 07417
(U.S.A. only)
General Business Group/International
44 South Broadway
White Plains, NY 10601
U.S.A. (International)

E/C 327517B
Page 48 of 48