

**IBM** Customer Engineering Instruction — Reference

**729 II, V Magnetic Tape Units (30,000 Series)**

**729 IV, VI Magnetic Tape Units (90,000 Series)**

## Foreword

This manual describes the theory of operation and servicing procedures for IBM 729 II, IV, V, and VI Magnetic Tape Units.

The manual covers theory of magnetic writing on tape, mechanical operating principles, circuit logic, and operation of some special component circuits in the tape units. It also includes sections on scheduled maintenance, assembly, removal, and adjustment, supplemented with sequence and condensed logic charts. Names of electronic lines are in quotation marks.

Information in this manual is directed primarily toward the IBM 729 II and IV Magnetic Tape Units but is generally applicable to 729 V and VI units. The basic differences in the 729 V and VI Magnetic Tape Units are explained in the final section.

Engineering changes may alter specifications, logic, and machine functions, causing a tape unit to differ from the description presented here.

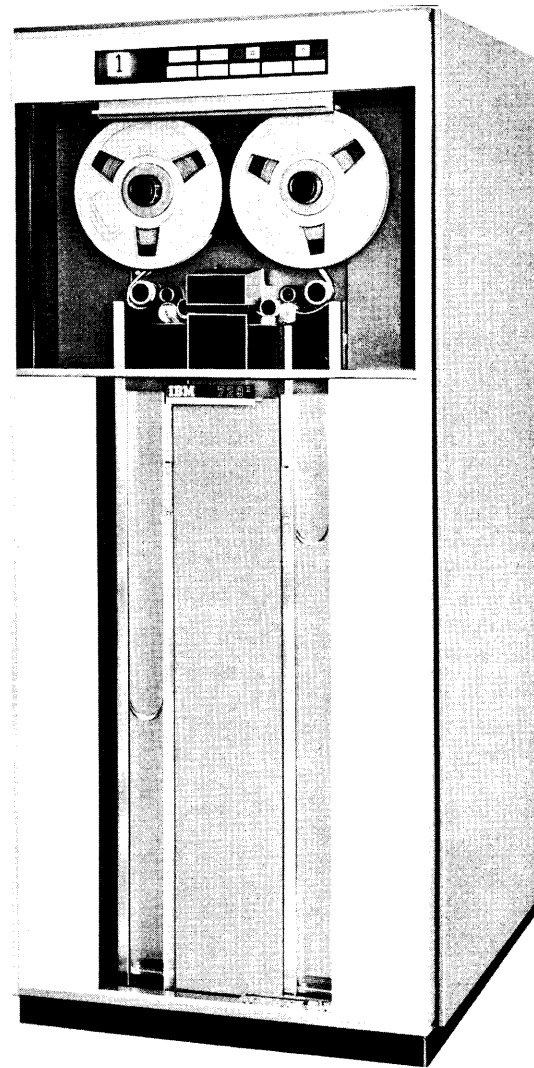

IBM 729 II Magnetic Tape Unit

Address comments concerning this manual to:

IBM Corporation  
Customer Engineering Manuals, Dept. 296  
P. O. Box 390  
Poughkeepsie, N. Y.

# Contents

	PAGE		PAGE
<b>729 II, IV, V, and VI Magnetic Tape Units</b> .....	5	Forward and Reverse Drive Motors .....	50
<b>MACHINE SPECIFICATIONS</b> .....	5	Reel Drive Clutches .....	50
Tape Unit .....	5	Tape Take-Up Mechanism .....	55
Mylar and H-D Tape .....	5	High-Speed Rewind .....	55
Humidity and Temperature Considerations .....	6	Eddy Current Sensing Device .....	56
Tape Capacity .....	6	BASE .....	56
<b>STORING INFORMATION</b> .....	6	Front Door Assembly .....	56
Magnetic Theory .....	6	Reel Door Interlock .....	58
NRZI System (Nonreturn to Zero IBM) .....	7	File Protection .....	58
<b>TAPE HANDLING</b> .....	8	Motors .....	59
Physical Conditions .....	8	Relays .....	59
Procedures and Precautions .....	9	Filters .....	59
<b>OPERATOR'S PANEL</b> .....	10	<b>Basic Circuit Functions</b> .....	60
Keys and Lights .....	10	INITIAL RESET .....	60
Operator's Panel Signal Lamps .....	10	Circuit Description .....	60
<b>CE TEST PANEL</b> .....	11	PROLAY OPERATION .....	60
Rear CE Panel .....	11	Circuit Description .....	60
Front CE Panel .....	12	<b>MAGNETIC CLUTCH CONTROL</b> .....	62
<b>NOR CIRCUITRY</b> .....	14	Circuit Description (NOR Logic Control) .....	62
Circuit Description .....	15	Circuit Description (Vacuum Switch Control) .....	63
sms Circuit Cards .....	15	<b>FILE PROTECTION</b> .....	64
<b>Scheduled Maintenance</b> .....	17	Circuit Description .....	64
Approach to Schedule Maintenance .....	17	<b>READ CIRCUIT</b> .....	65
Scheduled Maintenance Procedures .....	17	Circuit Description .....	65
Scheduled Maintenance Routine Chart .....	18	<b>WRITING CIRCUIT</b> .....	65
<b>Physical Description and Adjustments</b> .....	19	Circuit Description .....	65
<b>COMPONENT LOCATIONS</b> .....	19	<b>HIGH-LOW DENSITY</b> .....	66
<b>HEAD ASSEMBLY</b> .....	23	Circuit Description .....	66
General Description .....	23	<b>LOAD POINT</b> .....	68
Two-Gap Read-Write Head .....	26	Circuit Description .....	68
H-Shield Feed-Through .....	27	<b>TAPE INDICATE</b> .....	69
Erase Head .....	27	Circuit Description .....	69
Skew .....	27	<b>HIGH-SPEED REWIND SENSING</b> .....	69
Write Current .....	29	Objectives .....	69
Split-Guide Assembly .....	29	Circuit Description .....	70
Tape Cleaner Blades .....	30	<b>TAPE BREAK</b> .....	71
Photosensing .....	31	Circuit Description .....	71
Rewind Idlers .....	34	<b>Machine Operations</b> .....	72
Preamplifiers .....	34	<b>LOAD REWIND</b> .....	72
Head Raising Mechanism .....	34	Circuit Description (Low Speed) .....	72
<b>TAPE MOVEMENT</b> .....	34	Circuit Description (High Speed) .....	76
Prolay Assembly .....	36	<b>UNLOAD</b> .....	79
Prolay Specifications .....	38	Circuit Description .....	79
Prolay Servicing .....	38	Special Considerations .....	82
Short Inter-record Gaps at Low Go Down Time .....	45	<b>REWIND</b> .....	82
Stop Capstans .....	45	Circuit Description — Low Speed .....	82
Drive Capstans and Motors .....	45	<b>REWIND AND UNLOAD</b> .....	84
<b>VACUUM SYSTEM</b> .....	47	Circuit Description — Low Speed .....	84
Vacuum Columns .....	47	<b>Lines Entering and Leaving The Tape Unit</b> .....	88
Vacuum Column Switches (Diaphragm Switches) .....	47	<b>INPUT LINES</b> .....	88
Tape-in-Column Switches .....	48	<b>OUTPUT LINES</b> .....	88
Vacuum-Off Bellows Switch .....	48	<b>INPUT-OUTPUT LINE SPECIFICATIONS</b> .....	88
Flapper Valves .....	49	Input .....	88
<b>REEL DRIVE ASSEMBLIES</b> .....	50	Output .....	89

	PAGE		PAGE
<b>Service Aids</b> .....	90	- 48 Volt Supply .....	96
GENERAL TROUBLESHOOTING HINTS .....	90	+ 6 Volt Supply .....	96
Signal Drop-Out .....	90	Other Supply Circuits .....	97
Noise Pulses (Pickup) .....	90	Power Supply Maintenance .....	97
Noise and Ground Loops .....	90	CIRCUIT PROTECTORS AND THERMALS .....	98
False Noise Records .....	90	<b>Tape Switching</b> .....	99
Load-Unload-Rewind Failures .....	91	<b>IBM 729 V and VI Magnetic Tape Units</b> .....	102
Tape Contamination .....	91	CHARACTERISTICS .....	102
Tape Breakage .....	91	OPERATION AND ADJUSTMENTS .....	102
Magnetic Clutches .....	93	Read Circuits and Adjustments .....	102
Write Errors .....	93	Write Circuits and Adjustments .....	102
Miscellaneous Failures .....	94	I-O CONNECTORS .....	103
TRANSISTORS .....	94	<b>Special Component Circuits</b> .....	104
Identification and Substitution .....	94	READ PREAMPLIFIER .....	104
VOLTAGE CODING AND LEVELS .....	94	WRITE TRIGGER .....	105
Color Coding .....	94	HEAD DRIVER AND ECHO PULSE AMPLIFIER .....	106
Voltage Levels .....	94	LOAD POINT AND END-OF-REEL PHOTOSENSING .....	107
<b>Power Supply</b> .....	95	Circuit Description .....	107
MAGNETIC TAPE UNIT DC SUPPLY .....	95	CD--(CTRL THREE-WAY PNP NONTRANSLATING CIRCUITS) .....	108
Ferroregulator .....	95	Circuit Description .....	109
PHASE III POWER SUPPLY .....	96		

## Safety

Personal safety cannot be overemphasized. Follow all safety precautions at all times. Use the safety practices outlined in IBM Form 124-0002, a pocket-sized card issued to all customer engineers.

For the IBM 729 Magnetic Tape Units, observe all safety rules when working on or near high-voltage areas.

Observe caution whenever IBM Tape Developer Medium and Tape Transport Cleaner, P/N 517960, is used; be familiar with CEM 1203-76, or GP General CEM 24.

If the tape unit is placed in a high-speed rewind operation without a reel on the left side, the metal latch ring can fly off. When checking high-speed rewind circuitry, it is essential that a reel always be on the left side of the tape unit (with the hub tightened).

## IBM 729 II, IV, V and VI Magnetic Tape Units

Present-day computers require enormous amounts of input data that can be requested and received quickly. They also need a medium on which to record both permanent output information and large quantities of intermediate data that can be recalled quickly and conveniently.

The magnetic tape unit, with its almost unlimited capacity for holding information, fulfills this need by functioning as both an input and output device. It transports the magnetic tape and accomplishes the actual writing and reading on the tape.

The IBM 729 II and IV Magnetic Tape Units described in this manual are improved models of their 729 II and IV predecessors. The principal change is the replacement of relay circuitry with the new and reliable NOR-1 transistor logic. These new tape units are fully compatible with other IBM data processing equipment. IBM 729 V and VI Magnetic Tape Units are identical to the IBM 729 II and IV, except for having the added ability of reading and writing tape at the increased character density of 800 characters per inch.

There is no external distinction between the various models of NOR and relay type machines. These are assigned serial numbers as follows:

New relay machines 729 II and IV	70,000
New relay machines 729 V and VI	40,000
Factory reconditioned relay machines 729 II and IV	50,000
Factory reconditioned relay machines 729 V and VI	80,000
New NOR machines 729 II and V	30,000
New NOR machines 729 IV and VI	90,000

In field conversion of relay machines from 729 II and IV to V and VI, the tape unit retains its present serial number. Therefore, it is important to make specific reference to serial numbers during any correspondence or ordering of parts for a particular tape unit.

The tape units are controlled externally and have self-contained automatic and manual functions. AC voltage is obtained externally; all DC voltages for relay and electronic circuits are developed within the tape unit.

Some of the operations under program control include:

Writing	Rewinding
Reading	Unloading
Backspacing (both records and files)	

Mechanical and electrical operations of the 729 II and IV are similar except as shown in the following table.

	729 II	729 IV
Tape Speed (inches per second)	75	112.5
Record Density (bits per inch)	200—Low 556—High	200—Low 556—High
Character Time ( $\mu$ sec per character) for Reading and Writing	67—Low 24—High	44—Low 16—High
Character Rate per Second	15,000—Low 41,667—High	22,500—Low 62,500—High
Average Tape Access Time	10.8 ms	7.3 ms
Signal Levels	Transistor levels on input, output, and internally	Transistor levels on input, output, and internally

### Machine Specifications

The following machine specifications are approximate and vary slightly depending on model of tape unit and engineering level.

#### Tape Unit

Weight: 1200 pounds
Dimensions: 34 inches long by 29 inches wide by 69 inches high
Vacuum: 729 II, 8 inches of water; 729 IV, 16 inches of water
Voltage: 208v, three-phase, 60 cycles per second
Current per phase: 4.5 amperes
Input: 1.5 kVA

#### Mylar and H-D Tape

Width: 0.498 inch
Total thickness: .0019 inch
Ferromagnetic material and binder: .00045 inch
Tensile strength (minimum): 12 pounds

The main physical difference between Mylar\* and H-D tape is the binder used to secure the ferromagnetic coating to the plastic base material. H-D tape has better wear characteristics and gives longer service than regular Mylar tape. H-D tape is gray-black; regular Mylar tape is brown.

Magnetic tape used in data processing is of the highest quality. Each reel of tape is tested by IBM to eliminate conditions that could lead to errors in either

\*Trademark of E. I. duPont de Nemours & Co. (Inc.)

storing or reading information when using IBM magnetic tape equipment.

### Humidity and Temperature Considerations

Between 20 and 90 per cent relative humidity, Mylar tape varies .0023 inch. Proper tape storage is essential to satisfactory performance. If tape is stored where the relative humidity ranges between 20 to 80 per cent, design tolerances are maintained. If tape is stored in an atmosphere outside these specifications, the probability of errors increases.

Temperature variations are secondary to humidity. If the tape is stored at about 70°F, no departure from the specified width should be observed.

### Tape Capacity

Information may be written in any of seven tracks across the face of the tape. Each track is independent of every other track. See Figure 1.

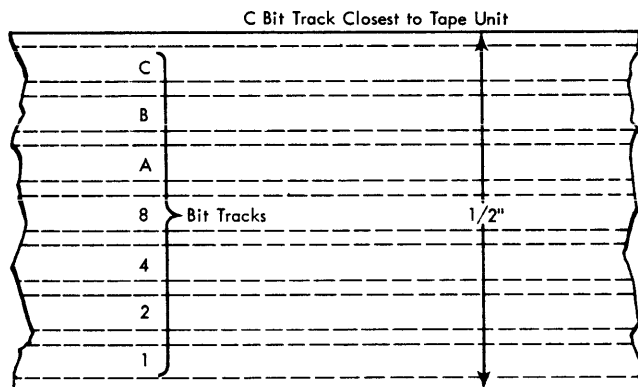

Figure 1. Bit Tracks on Tape

As tape is fed through the tape unit, the writing of characters (bits) is controlled by write pulses generated in the external control. Information is placed on tape in any desired bit configuration. Configuration and interpretation are determined by the external control.

Tape capacity is greatly affected by the inter-record gap (distance required to stop and start the tape). About 1/4 inch is required to stop tape; about 3/8 inch is required to get tape up to speed. (For accuracy, a write delay is built into the external control, so that total tape travel before writing is about 1/2 inch.) The combined distance required to stop and start writing is 3/4 inch. Through good programming, records may be grouped to eliminate some inter-record gaps and conserve space on tape.

## Storing Information

### Magnetic Theory

A magnetic material can be polarized or partially polarized under the influence of a magnetic field. For every magnetic material, a B-H curve (Figure 2) can be plotted. The B-H curve shows the resultant flux densities (B) when the material is placed under the influence of a varying magnetizing force. If a magnetizing force of ampere-turns (H) is slowly increased in the positive direction, the resultant flux density in a magnetic medium at first increases rapidly, then slowly attains a steady value of flux.

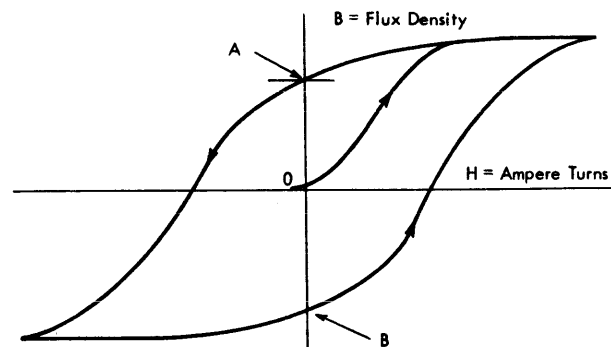

Figure 2. B-H Curve

The phenomenon of attaining a steady value of flux density is called saturation of the magnetic material. When the ampere-turns are slowly reduced, flux density also decreases, but at a different rate. This is the hysteresis effect. When the magnetizing force is again zero, the flux density is not equal to zero, but is equal to some positive value (point A). The amount of magnetic flux remaining (distance A-O) when H is equal to zero is the residual magnetism in the material.

If the ampere-turns are reversed by a reversal in current, flux density is increased in the negative direction until saturation again is reached. When current magnitude again is returned to zero, a negative resultant flux remains (point B). Using suitable circuit techniques, a flux pattern of either positive or negative polarity can be impressed on a magnetic material.

Figure 3 shows how information is stored on magnetic tape. The magnetic circuit consists of a laminated core, an air gap, a Mylar shim, and magnetic oxide on the tape. The core is MuMetal†, which has a high permeability and low retentivity. Permeability is the ability of a magnetic material to conduct lines of flux;

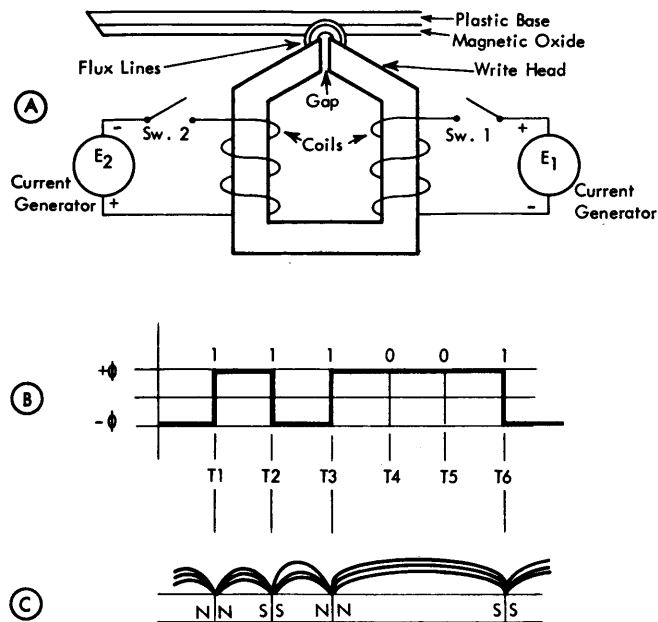

Figure 3. Method of Writing on Magnetic Tape (NRZI)

it is designated by the Greek letter Mu ( $\mu$ ) and is numerically equal to the ratio of the flux density to the magnetizing force ( $\mu = B \div H$ ); the mu of air = 1. Retentivity is the capacity of a magnetic material to retain magnetism after the magnetizing force is removed. The oxide has a low permeability of about 7-9 and a high retentivity. The half-mil (0.0005-inch) write gap causes the magnetic lines of flux to diverge away from the head and into the magnetic oxide on the tape. The shim prevents loose oxide from filling the gap.

### NRZI System (Nonreturn to Zero IBM)

#### INTRODUCTION

The NRZI system of recording binary information is one in which tape is continuously saturated in either the positive or negative direction. Within a given period of time, a change in saturation polarity is called a one, and no change is called a zero. The process of storing information is writing and the process of detecting stored information is reading.

†Trademark of Allegheny Ludlum Steel Corporation

#### OPERATION

When switch 1 (Figure 3A) is closed at time T1, current generator E1 causes current to flow through the coil; a flux path is set up as shown by the arrows. Because this flux path extends into the magnetic oxide on the tape, the oxide particles are magnetized in the direction of the flux path. If the tape is moving, all of the area passing over the write head is magnetized in the same direction.

If, at time T2, switch 2 is closed and switch 1 is open, current generator E2 causes current to flow through the opposite write coil. This causes the flux path to be reversed and the oxide particles to magnetize accordingly. Because the switching time is very short, the tape moves only a minute distance during the reversal. This process constitutes writing a one bit on the tape. If, at time T3, the flux in the head is again reversed, another binary one is written. If, at time T4, no reversal is made, a binary zero is written. Thus, if a reversal in flux is made at any time, a binary one is written; if no reversal is made, a binary zero is written.

The magnetic material on the tape can be considered as a series of tiny bar magnets placed end to end. Where the change in flux occurs, there are like poles; where no change occurs, there appears to be one long magnet (Figure 3C).

Reading a binary one makes use of the principle that a voltage is induced in a coil whenever there is change of flux cutting the turns of the coil. (This can be stated in the fundamental equation:  $e = -Nd\phi/dt$ .) When a reversal of flux pattern is encountered as the tape is passed over the head, a voltage pulse is induced in the windings. This voltage is routed to amplifier circuits.

A binary one is sensed as a voltage pulse at the terminals of the coil. (This pulse is produced by a flux change in either direction.) The absence of a pulse (no change in flux) indicates a binary zero.

The IBM 729 II and IV tape units employ a two-gap head that provides a means of reading a record during the same writing pass. This technique allows validity checking of the tape record as it is produced, and provides greater reliability in reading during subsequent operations. An erase head is also provided and used during a write operation to insure good erasure of old information before new information is written.

The advantages of the NRZI system are:

*High Inherent Density:* Binary ones can be written closer together than in a pulse system.

*High Output When Reading:* Maximum change of flux occurs from one saturation level to the other.

*Simplified Erasing Technique:* Erasing to saturation is simpler than erasing to zero flux. (Writing a new record erases the old record.)

## **Tape Handling**

IBM magnetic tape is so durable that any limitation to successful use is almost always caused by physical damage, by the presence of cumulative wear products, or by contaminating foreign particles such as dust. Consequently, tape must be handled with care at all times to protect and extend its life. Also, maximum cleanliness must be preserved in and around tape units, tapes, reels, containers, and the general areas of use. Recommended conditions of temperature and relative humidity must be maintained.

Dust, dirt, or damage to the tape can reduce or prevent the necessary physical contact between the oxide surface of the tape and the read-write unit. Signal strength may be sharply reduced or information may be completely obliterated.

Because recorded information comes within .024 inch of the edge of the tape, tiny nicks and kinks caused by careless handling of tape or reel may seriously affect the quality of magnetic reading or recording. Damaged tapes are as ineffective as chipped or broken phonograph records.

As a result of the complete testing of each reel of magnetic tape throughout its length, no error-producing defects are present at the time of shipment to the customer. But after continued use, normal wear products may be generated and collect on the tape, foreign material may accumulate if proper handling procedures and precautions are not observed, or the tape may be inadvertently damaged.

Foreign material, wear products, a crease, or any condition that causes the tape to be lifted as little as .0005 inch from the read-write unit causes a signal loss of 60 per cent. Lifting the tape away from the read-write unit .001 inch results in a signal loss of 87 per cent, thus reducing the signal below the effective sensitivity of the read-write unit.

These errors are not confined only to the area directly under a particle. They also are produced in any adjacent area of tape that does not achieve physical contact as it travels over the read-write unit.

### **Physical Conditions**

Several characteristic physical conditions are sometimes found during the use of magnetic tape. With a proper understanding of these conditions, the customer can avoid complications which otherwise might arise.

#### **TAPE WRINKLE**

Excessive torque on reel clutches causes tape wrinkle.

#### **IRREGULAR WINDING**

Normally, tape winds on the reel with some of the edges slightly protruding. These irregularities usually

result from high-speed rewinding, which causes air to be trapped between adjacent layers of tape. Another contributing factor may be static electricity.

In itself, slightly protruding edges do not interfere with the proper operation of tape. It does require, however, that proper care in handling tape be exercised by all operating personnel. The exposed tape edges can be badly damaged if they are squeezed through the reel openings or pinched in the edges of the reel.

#### **WAVY EDGE**

One condition that can give magnetic tape the appearance of having a wavy edge is curvature. If a short length of tape is spread flat on a clean surface, its edge will not be perfectly straight but will form a slight arc. The arc should not exceed  $\frac{3}{8}$  inch in 36 inches of tape. Otherwise, the tape tends to turn in the vacuum columns. A nominal curvature is present to some degree in almost all tapes. Although it may produce a slight flutter in the vacuum columns, a curvature less than  $\frac{3}{8}$  inch in 36 inches of tape does not interfere with proper operation.

Another condition that can cause magnetic tape to exhibit a wavy edge results from edge damage. If the tape reel is improperly mounted, the edge of the tape will receive undue wear and become burred. This burr causes one edge of the tape to be slightly thicker than the other. When wound on a reel, the edge of the tape with the burr will wind to a larger diameter than the undamaged edge. After a period of time, the center of tape will be permanently stretched. A tape in such condition will prove unpredictable and generally unsatisfactory. The read errors encountered are usually of the random, nonrepetitive type.

#### **CUPPED TAPE**

The outside layers of tape sometimes have a cupped appearance; that is, the oxide side of the tape may appear slightly concave.

Acetate tape may sometimes exhibit this condition when first removed from the plastic shipping bag. The cupping occurs when the relative humidity of the surrounding air is increased over a short period of time. (An increase in relative humidity can be the result of a sudden drop in air temperature as well as an actual increase of moisture content.) The acetate reacts to the humidity increase by expanding slightly, while the oxide coating does not. The cupped effect does not interfere with the proper operation of the tape and disappears after a few passes through the tape unit.

#### **REEL WARPAGE**

Reels must be properly supported when not in use. The plastic container provided has been designed so



that a reel is fully supported. A reel that is supported in any other manner may become warped.

One common reason why a reel wobbles or appears to be warped during use is that the reel may not be seated properly on the hub. The same effect is produced if the file protect ring is not inserted completely and the reel is, therefore, not fully seated. In either case, the reel behaves as if it is warped, and can produce damage to the edges of the tape.

### **Procedures and Precautions**

The recommended conditions of temperature and relative humidity for operating IBM magnetic tape are as follows:

#### **RECOMMENDED OPERATING CONDITIONS**

The recommended operating conditions for both Mylar and H-D tape are relative humidity of 20 to 80 per cent and a temperature of 50 to 90 degrees F.

For extended storage of Mylar at humidities greater than 80 per cent, tape reels must be hermetically sealed within moisture-proof plastic bags. This prevents the formation of mold growth and fungus.

#### **OPERATING PROCEDURES**

Smoking should not be allowed in the machine room. Ashes can contaminate tape. Live ashes can produce permanent damage if they touch the surface of the tape.

Tapes that contain useful information must not be exposed to magnetic fields with an intensity greater than 50 oersteds.

During loading, the tape should be taken directly from the container and mounted in the tape unit. After unloading, the tape should immediately be replaced in its container.

Extreme care must be used while removing the file protect ring. Under no circumstances should the ring be removed while the tape is loaded in the columns.

When being loaded, the reels should be pushed firmly against the stop on the mounting hub to insure good alignment.

Special precautions should always be taken to make sure that the hub has been tightened during loading.

To wind the take-up reel to the load point, rotate the reel with the finger in the recessed finger hold on its surface. Rotating the reel with the finger in the cut-out will nick or curl the guiding edge of the tape.

While the tape is on the machine, the container should be closed and put in some location where it is not exposed to dust or dirt.

The tape unit should be allowed to complete the unload sequence before the door is opened.

The reels should be handled near the hub whenever possible. If difficulty is encountered while removing the reel, the bond between the reel and the hub can be broken by placing the palms of the hands along the edges of the reel and rotating it. The reel should never be rocked by grasping the outer edge. If a tape break occurs, the reel should be divided into two smaller reels. Splicing is not recommended. If it is necessary to make a temporary splice to recover information, special low-cold-flow splicing tape should be used.

Be careful when placing reflective strips on tapes. Trouble may result if the tape is soiled or damaged in the process.

#### **GENERAL HANDLING PROCEDURES**

Do not use the top of a tape unit as a working area. Placing material on top of the unit exposes it to heat and dust from the blowers. It may also interfere with cooling of the tape unit.

A reel card holder is provided for identifying tape reels. If adhesive stickers are used, make sure they do not leave a residue. Use stickers that can be easily applied and removed. Never alter labels with an eraser.

A loose end of tape should never be allowed to trail on the floor.

When necessary to clean tape, gently wipe the tape with a clean, lint-free cloth moistened with the proper tape transport cleaner. Extended exposure of tape to the solvent should be avoided; damage to the tape can result.

Periodically inspect the plastic tape reel containers for accumulated dust. Containers can be cleaned with a vacuum cleaner or by washing with a regular household detergent.

Pinching of the reels and any contact with the exposed edges of the tape should be carefully avoided.

Dropping a reel can easily damage both reel and tape and make their subsequent use unsatisfactory.

Reels of tape, whether in or out of a container, should never be thrown or carelessly handled.

#### **STORAGE PROCEDURES**

The tape must be supported at the hub and kept in its container to protect it from dust when not in use.

Tapes should be stored in some type of cabinet elevated from the floor and away from sources of paper or card dust. This should minimize the transfer of dust from the outside of the container to the reel during loading or unloading operations.

Before reels are stored, sponge rubber grommets should always be placed on the reels to prevent the free end of the tape from unwinding in the container.

If shipping of tape reels is necessary, the tape and reel should be packed in the plastic container provided

for this use. The container should be hermetically sealed in a plastic bag. Additional support should be obtained by packing in individual stiff cardboard shipping boxes.

### Operator's Panel

The operating keys and lights (Figure 4) are located in the front upper section of the tape unit.

#### Keys and Lights

**Select Switch:** This is a rotary switch located at the left of the group. It is used to set the tape unit to one of ten addresses associated with an external control. The select switch is mounted horizontally and is operated by a large diameter knurled disk. Only a small section of the disk protrudes from the panel. The selected address is indicated on an illuminated translucent band which rotates with the knurled disk.

**Select Light:** The select light is on when the tape unit is selected by an external source.

**Start Key:** Pressing the start key places tape unit under computer control and in ready status if the tape unit is fully loaded and mechanically ready. The start key may be pressed during a load or rewind operation, but the tape unit will not be in the ready status until conditions are satisfied.

**Reset Key:** This key removes the tape unit from computer control and turns off the ready light. In addition, it returns a high-speed rewind to low speed. It completely stops a low-speed rewind. The reset key also suspends either loading or unloading of tape in the columns.

**Ready Light:** This light is on if the tape unit is in ready status. Manual control is indicated when the ready light is off, if the tape unit is not rewinding or loading.

**Load-Rewind Key:** Pressing this key starts two operations: loading tape and searching for the load point. If tape has been unloaded manually in the high-speed rewind area of the tape (more than one-half inch of

tape on machine reel), pressing this key executes a high-speed rewind before the load and search operations take place. This key is inoperative unless the tape unit is under manual control.

**Unload Key:** Pressing this key causes tape to be pulled out of the columns and the upper head assembly to rise, regardless of the distribution of tape on the two reels. If the tape is not at load point when the operator wishes to change tape, a load-rewind operation should be completed before the unload operation is started. This key is inoperative unless the tape unit is under manual control.

**Change Density Key:** Pressing this key changes the present density status of the tape drive (high to low, or low to high).

**Density Lights:** These lights indicate the density status of the machine.

**Tape Indicator Light:** This light is lit when the tape indicator is turned on by sensing the end-of-reel reflective spot on tape while writing. It may also be turned on or off under external control. Unloading also resets the indicator.

**File Protection Light:** This light is conditioned to turn off by mounting an unprotected reel on the unit (ring in file reel). It is on (1) if no file reel is mounted, (2) if a file reel with no ring is mounted, (3) during a load or rewind operation.

**Fuse Indicator Light:** This light is on when any circuit protector except AC circuit protector 1, 2, or 3 or DC circuit protector 1 is tripped.

#### Operator's Panel Signal Lamps

Use only 55B lamps, P/N 344987, as replacements in the operator's panel. Do not use 55C lamps, P/N 308346, because they have a shorter life than the 55B type. The type number and suffix are stamped on the base of the lamp.

#### REMOVAL

To remove panel lamps, use a laminar bus extraction tool, P/N 461074.

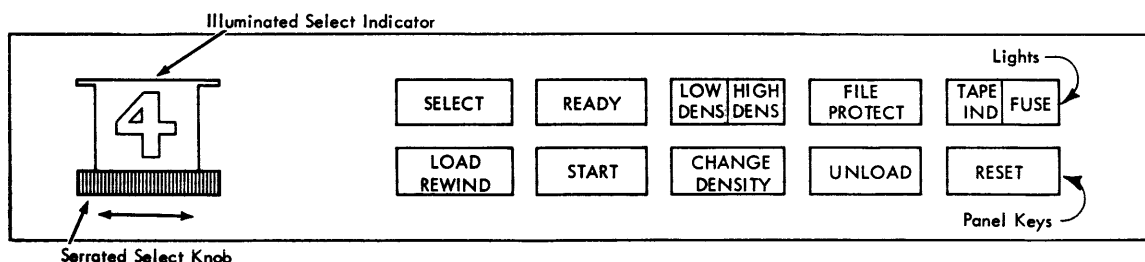

Figure 4. Operator's Panel

## CE Test Panel

Each 729 II and IV Magnetic Tape Unit is equipped with the necessary controls to allow on-line checking of all essential operations and functions. Two panels provide the lights, switches, and test points. All necessary circuitry either exists in the machine or is provided on one additional double SMS card. One of these cards is supplied for each installation and is inserted by the customer engineer at checkout time.

One multiwafer selector switch makes it possible to logically remove the tape unit from the system. This provides a means of easily removing a faulty unit from the system and allows customer engineering on-line testing without interfering with the customer's operation.

## Rear CE Panel (Figures 5, 6, and 7)

### SWITCHES

**On Line/Off Line Switch (Sw 24):** This multiwafer switch logically disconnects the tape unit from the system with no need for cable removal, power transfers,

or customer interruption. Its effect on the tape unit is to: (1) Block all necessary input signals at the I-O cable, (2) hold all I-O output levels at +S (ground) to prevent introducing signals onto the main I-O bus, and (3) activate the keys and switches available for CE use (see Figure 5).

**Start-Reset (Sw 14):** This three-position spring-returned switch parallels the switches on the operator's panel and either brings up or drops ready status.

**Load-Unload (Sw 15):** This three-position spring-returned switch parallels the operator's panel switches to cause loading or unloading if the tape unit is not in ready status.

**Set Read/Set Write (Sw 12):** This three-position switch allows the tape unit to be set to either read or write status. It is normally used with the backward-auto-manual (Sw 13) and start stop-manual-suppress GO (Sw 9) to accomplish read or write cycling of the tape.

**Turn TI On/Turn TI Off (Sw 11):** This three-position switch turns the tape indicator on or off if the tape unit is in ready status.

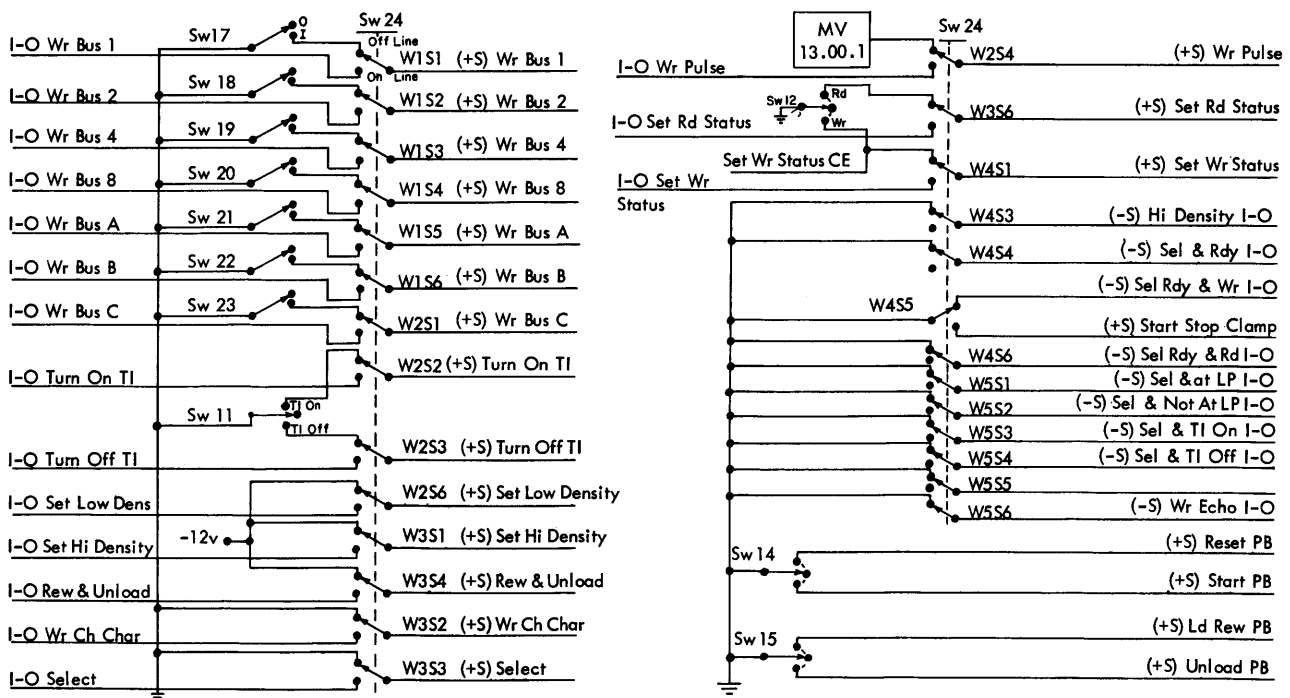

Figure 5. CE Panel Switches

**Manual-Auto-Backward (Sw 13):** See Figure 6.

**MANUAL**—with switch 9 in either the START-STOP or MANUAL position, reading or writing is under control of the start and reset keys. Pressing the start key causes the operation to continue until either the reset key is pressed or the end-of-tape reflective spot is sensed. At this point, the operation ceases. Note that the ungated output of the TI photocell is used to reset the CE GO trigger. This pulse is available during a read or a write operation.

**AUTO**—This operation is similar to the MANUAL position except that cycling automatically occurs at end of tape (A2) and at load point (A1). Sensing the output of the TI photocell turns off the CE GO trigger and initiates an automatic rewind to load point. Load point sets the CE GO trigger and again restarts the cycle. Final stopping is under control of the reset key. To maintain a write cycling operation, it is necessary to leave switch 12 at SET WRITE. The first rewind initiated by the TI photocell causes a reset of the write trigger

until load point is reached. If switch 12 were returned to its neutral position, a read cycle operation would occur after the first pass of tape.

**BACKWARD**—This position of the switch causes tape to backspace under either manual or variable start-stop go control until load point is reached. Load point circuitry prevents any further motion beyond this point and there is no cycling.

**Bit Switches (Sw 17-23):** These switches control the writing of either ones or zeros in their respective tape tracks.

### Front CE Panel (Figure 8)

#### SWITCHES

**Backward/Forward (Sw 10):** This switch allows control of forward or backward motion from the front CE panel and is used with the backward-auto-manual and start stop-manual-suppress go switches.

**Start Stop-Manual-Suppress GO (Sw 9):**

**START STOP**—This setting allows go to rise and fall under control of a multivibrator and its associated potentiometer and the high-low-medium frequency switch (Sw 8). Once the start key is pressed and the CE GO trigger is turned on, the tape unit reads or writes under variable start-stop control.

**MANUAL**—In this position the multivibrator is removed from the circuit and “go control” is allowed to float into A3 (Figure 6). GO is now under control of the start and reset keys.

**SUPPRESS GO**—This position prevents go from becoming active by holding the lower leg of A3 to -6 volts. Suppress go also automatically sets write status because this setting is normally used to check H-shield feedthrough and prolay adjustments.

**High-Low-Medium Frequency (Sw 8):** Start-stop time of the tape unit can be varied by this switch and associated potentiometers. The approximate range for each setting is:

Low — 1-15 milliseconds

Medium — 15-175 milliseconds

High — 100 milliseconds-5 seconds

By syncing on the “go” line and observing the pre-amplifier output, start-stop times can be displayed for either forward or backward operations.

#### LIGHTS

**I-C Bit** indicates the status of its associated write trigger.

**Write Status** indicates either write status (on) or read status (off).

#### SYNC POINTS

**I and C Bits** are not used.

**GO** indicates the output of “internal go.”

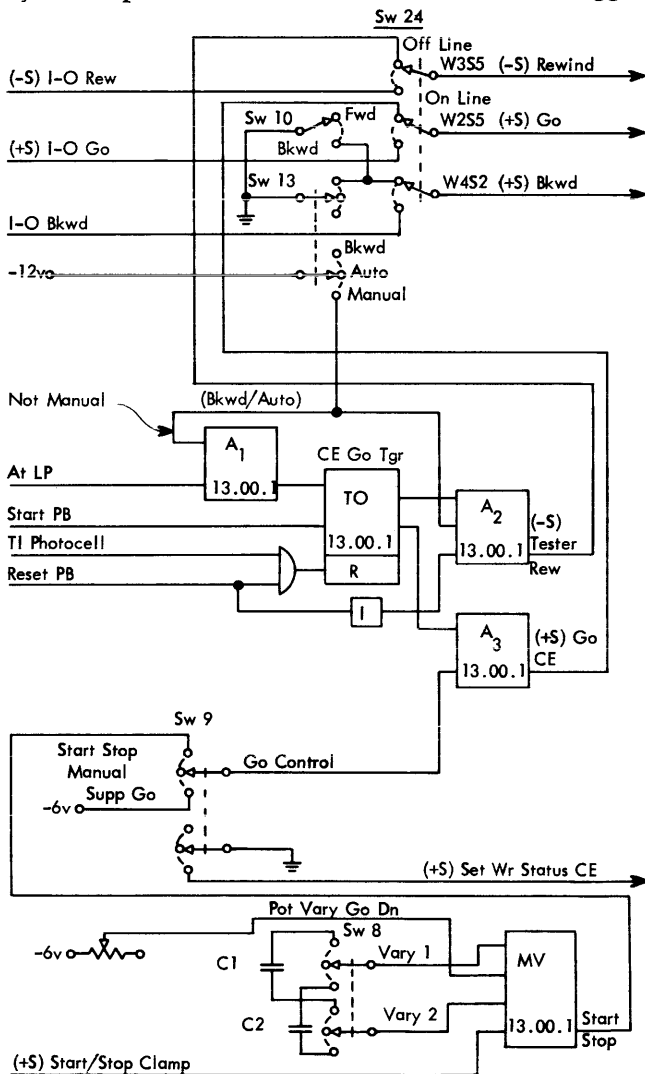

Figure 6. CE Tester Control

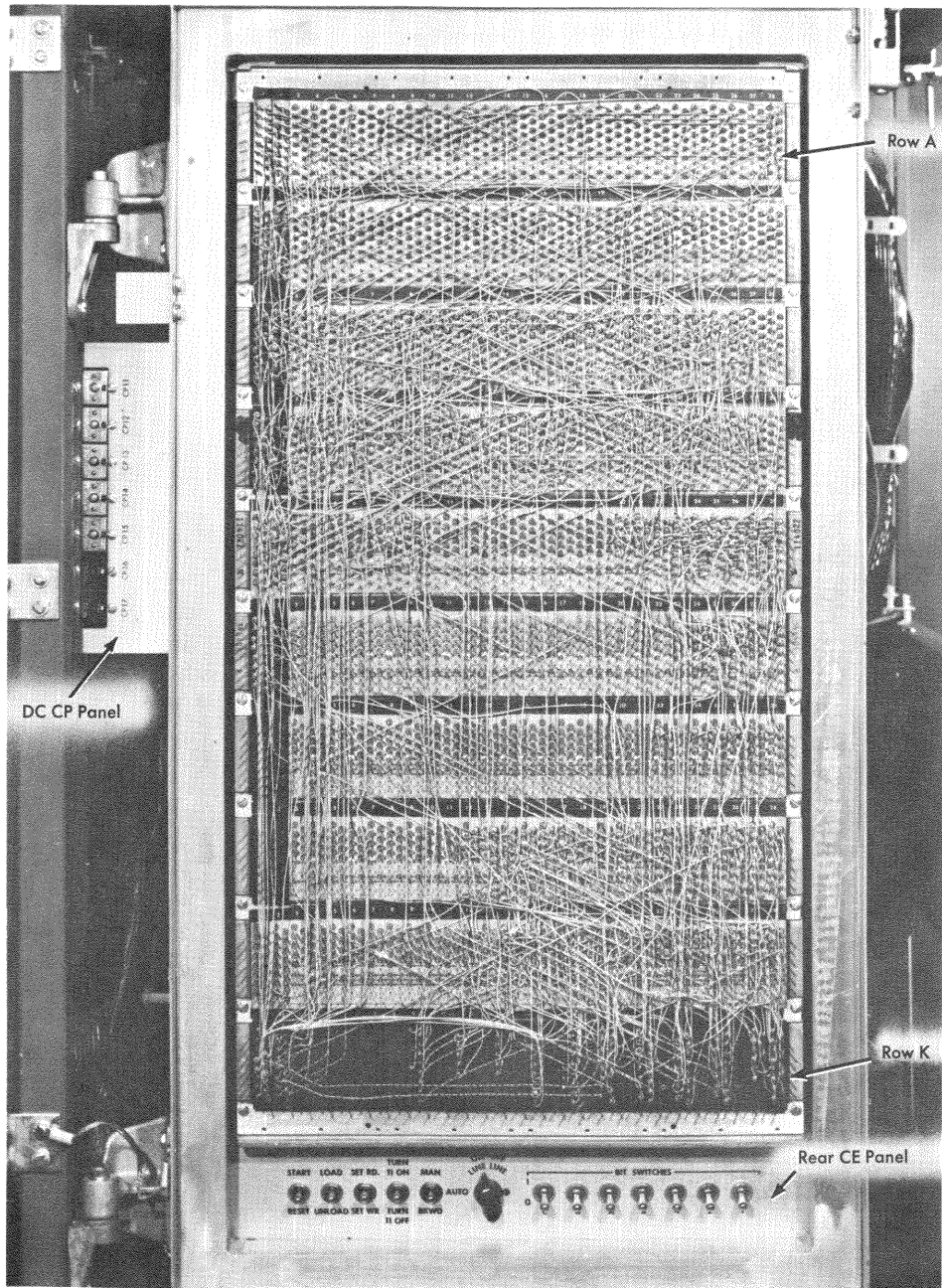

Figure 7. Rear Logic Panel

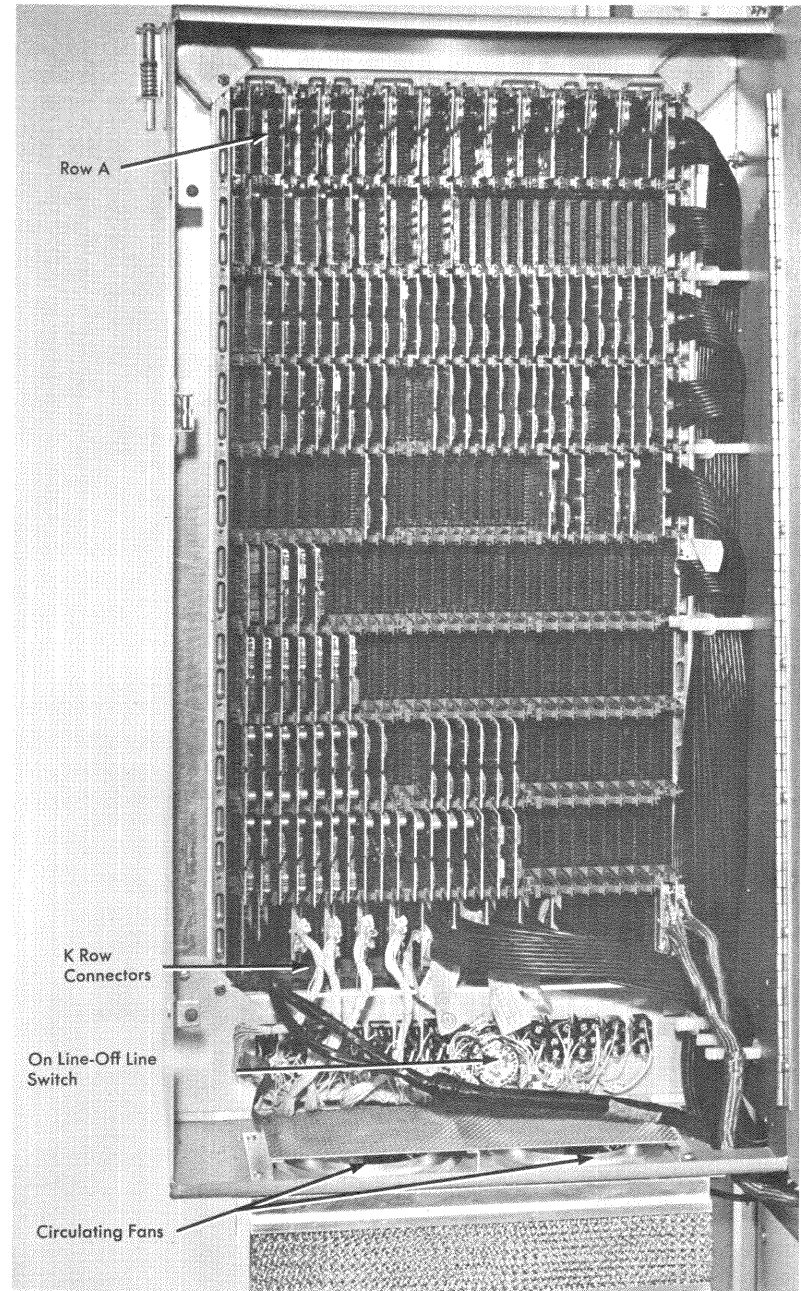

Figure 7A. Read Logic Panel (Card Side)

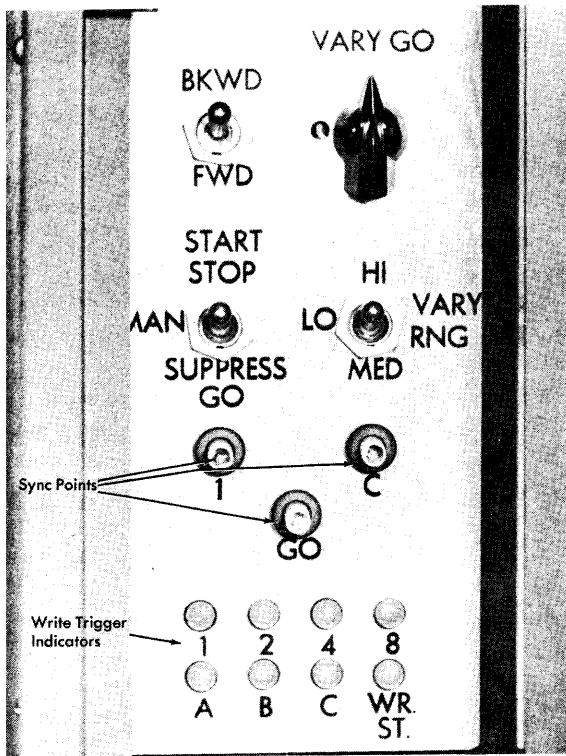

Figure 8. Front CE Panel

### NOR Circuitry

The 729 II and IV Magnetic Tape Units utilize NOR-1 circuitry. NOR logic is a collection of NOR and NAND and implies NOT OR and NOT AND.

Conventional OR and AND circuits are shown in Figure 9. The output of the OR block is positive if either or both of the inputs are positive and is negative only when both inputs are negative. The AND output is positive only when all inputs are positive; any input going negative drops the output.

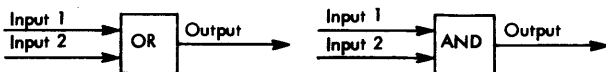

Figure 9. Conventional OR and AND Circuits

NOR and NAND have a similar meaning, except that they produce the additional effect of an inverter immediately following the circuit. A NOR block, then, is the equivalent of an OR block followed by an inverter (Figure 10). A NAND block is equivalent to an AND block followed by an inverter.

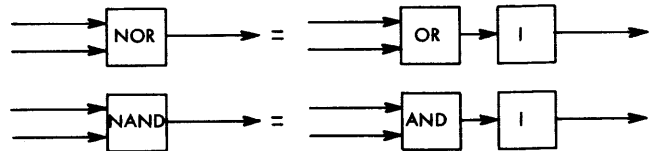

Figure 10. NOR Circuit Equivalents

In this manual, NOR blocks always show a -O; NAND blocks show a +A. In each case, the effect of an inverter is present. In some cases to show simplified or second level system circuits positive logic may be shown. Here, the signs are omitted; an OR circuit is shown as an O, an AND is shown as an A, and there is no implied inversion.

In the logic design of computers, only three basic elements are required to meet any desired set of conditions. These three basic blocks are OR's, AND's and inverters. Other elements—triggers, amplifiers, drivers, and so on—are also used to make the machine fully operational, but the controlling logic only requires the three basic functions.

With NOR circuitry, the combination of two of these elements has been realized: OR and inversion, and AND and inversion. Figure 11 shows that either a one-legged NOR or a one-legged NAND circuit is equivalent to an inverter.

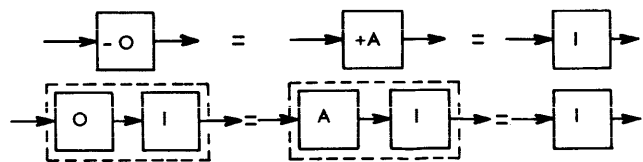

Figure 11. One-Legged NOR Inverter

The NOR and NAND circuit blocks are identical electronic circuits (Figure 12). Thus, a two-legged logic block could be either a two-legged NOR (-O) or a two-legged NAND (-A) depending on the particular logic demand of the circuit. This means that all logic design

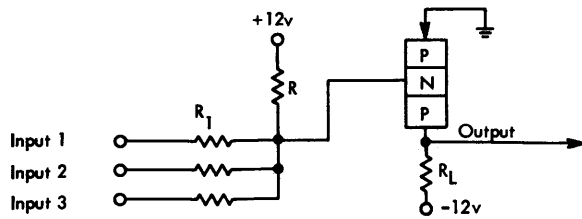

Figure 12. Three-Legged NOR Circuit

within the 729 II or IV tape unit can be accomplished with one type of circuit or SMS card, making possible mass production of these parts and correspondingly fewer SMS card part numbers per machine.

Also, the NOR circuitry achieves both voltage and current gain; a signal can travel through an unlimited number of stages without degeneration.

#### Circuit Description

The basic PNP NOR circuit is shown in Figure 12 and is a saturating voltage mode circuit. The input and output levels are either at  $-12$  ( $-S$ ) or ground ( $+S$ ).

The transistor is turned on (saturated) whenever any one of the three inputs is at a down level. For the transistor to be cut off, all inputs must be up to ground level (0 volt). The three input resistors provide the logic function. The transistor inverts the base input signal, establishes an ON level (level setting), and supplies the necessary powering.

The maximum number of inputs is three. The maximum number of outputs depends on the type of load-

ing and usually is either three or four. The main requirement is that the down ( $-S$ ) level should not become more positive than  $-5.56$  volts.

#### SMS Circuit Cards

NOR-1 circuits use either two or three inputs; therefore, two SMS cards are provided. The  $CO$  card (Figure 14) contains three 3-input circuits. The  $MX$  card (Figure 15) contains four 2-input circuits.

At times it is necessary to have more than three inputs to a NOR circuit block. This is accomplished by making one of the circuits an extender. On both the  $CO$  and  $MX$  cards, one circuit has a break in the load circuit. By connecting the output (collector) of this transistor to the load of one of the other circuit transistors so that there is a common load, it is possible to make a five-legged block (Figure 13).

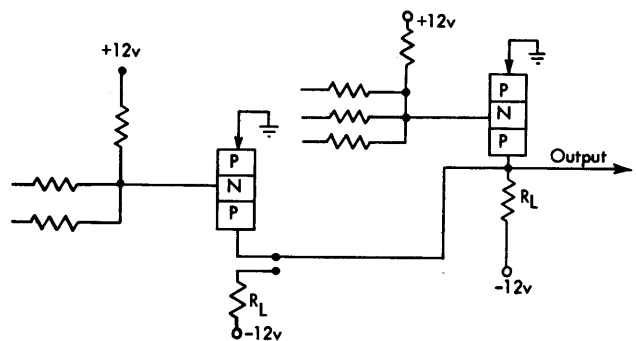

Figure 13. NOR Extender Circuit





## Scheduled Maintenance

### Approach to Scheduled Maintenance

The prime objective of any maintenance activity is maximum machine availability to the customer. Every scheduled maintenance operation should assist in realizing this objective. Unless a scheduled maintenance operation cuts machine downtime, it is unnecessary.

Do not adjust or disassemble a unit that is working properly, even if tolerances vary from specification.

### VISUAL INSPECTION

Visual inspection is the first step in every scheduled maintenance operation. Always look for corrosion, dirt,

wear, cracks, binds, burnt contacts, and loose connections and hardware. Alertness in noticing these items may save later machine downtime.

### Scheduled Maintenance Procedures

Specific items of scheduled maintenance are scheduled on punched cards in the local customer engineering office. Details of scheduled maintenance operations are listed in the Scheduled Maintenance Routine Chart (Figure 16). During normal scheduled maintenance,

SCHEDULED MAINTENANCE ROUTINE CHART

ROUTINE	FREQ WKS	OPERATION	OBSERVE																		
0	Note 1	Scope start-stop time	Waveforms and timings																		
		Lubricate armature and arm pivot shafts with Aeroshell 14. Lubricate nylon idler pivot shaft with IBM 4	Replace defective parts. Do not lubricate proloy dust seals																		
1	13	Filters - Visually check filters. Replace as required	Blower motors for proper operation																		
		Use CE panel to move tape continuously	Tape operation in vacuum columns (sluggish operation may indicate powder leakage from magnetic clutch). Check tape break circuit and high-speed rewind If clutches are sluggish, check response with DC tachometer as described under reel clutch drive adjustment																		
2		Clean base is required	Capstan motors and high-speed rewind idlers for binds. Vacuum switches for broken or cracked straps and pitted points. Tape cleaner blade for damage. Belts for wear and tension. Capstan motor mounts and front bearing for play																		
3		Check H-shield for binds or cocking	Position with respect to gaps																		
		Check magnetic clutch brushes	Wear and arcing																		
		Check for write feed-through	With no tape movement (disconnect capstan motors) write 1's in all tracks. At the read bus there must be less than 0.40 peak-to-peak voltage																		
		Check read-write skew	Readjust skew if any track is out by more than .25 microsecond																		
		Check write asymmetry (729 V and VI)	Coincidence of outputs from skew register A in TAU while writing 1's.																		
9		Misc lubrication IBM 6 - Capstan shaft and motor bearings, head assembly felt oil pads and pivot points IBM 17 - Vacuum column cover latches	No lubricant should be used in the vacuum column area																		
8	26	Power Supply - Check voltage levels and ripple at specified points	<table border="1"> <thead> <tr> <th>Voltage</th> <th>Ripple</th> <th>Test Point</th> </tr> </thead> <tbody> <tr> <td>-6 ± 0.24</td> <td>0.48</td> <td>A3K01M</td> </tr> <tr> <td>+6 ± 0.24</td> <td>0.48</td> <td>A3K01H</td> </tr> <tr> <td>-7.5 ± 1.5</td> <td>3.30</td> <td>A3K01P</td> </tr> <tr> <td>-12 ± 0.48</td> <td>0.96</td> <td>A3K01G</td> </tr> <tr> <td>+12 ± 0.48</td> <td>0.96</td> <td>A3K01A</td> </tr> </tbody> </table>	Voltage	Ripple	Test Point	-6 ± 0.24	0.48	A3K01M	+6 ± 0.24	0.48	A3K01H	-7.5 ± 1.5	3.30	A3K01P	-12 ± 0.48	0.96	A3K01G	+12 ± 0.48	0.96	A3K01A
Voltage	Ripple	Test Point																			
-6 ± 0.24	0.48	A3K01M																			
+6 ± 0.24	0.48	A3K01H																			
-7.5 ± 1.5	3.30	A3K01P																			
-12 ± 0.48	0.96	A3K01G																			
+12 ± 0.48	0.96	A3K01A																			

Note 1: Frequency of proloy maintenance should be determined by gap diagnostics and/or customer performance.

Figure 16. Scheduled Maintenance Routine Chart

perform only the operations listed on the chart for that scheduled maintenance period.

#### **ELECTRONIC CIRCUITS**

Diagnostic programs, marginal checking, and pulse checking are three basic tools for scheduled maintenance of electronic circuits; all are effective in locating potential and intermittent troubles. These items are also excellent troubleshooting tools. For scheduled maintenance, use them only as directed on the scheduled maintenance chart.

Do not adjust pulses unless the condition of the machine warrants it.

#### **MECHANICAL UNITS**

The three basic scheduled maintenance steps performed on every mechanical or electromechanical machine are clean, lubricate, and inspect. Remember: Do not do more than recommended scheduled maintenance on equipment that is operating satisfactorily.

#### **Scheduled Maintenance Routine Chart**

Read Figure 16 before doing scheduled maintenance. Observe all safety practices.

## Physical Description and Adjustments

### Component Locations (Figures 17, 18, 19, 20)

The front of the tape unit (Figure 17) contains the door assembly, customer controls and indicators, CE panel and adjustments, access to the preamplifier circuit panel, and tape transport and column assembly.

The transport assembly contains the tape reels, columns, read-write head, prolays, and associated parts. It is secured to the welded frame unit at three points

by transport shock mounts. In the upper section, behind the front plate, are the reel and capstan drive motors, head and tape take-up motors, high-speed rewind and fan motors, reel clutches, file protect relays, and associated mechanical couplings and wiring.

The lower center area contains the power supply assembly, vacuum motors, and preamplifier circuit housing.

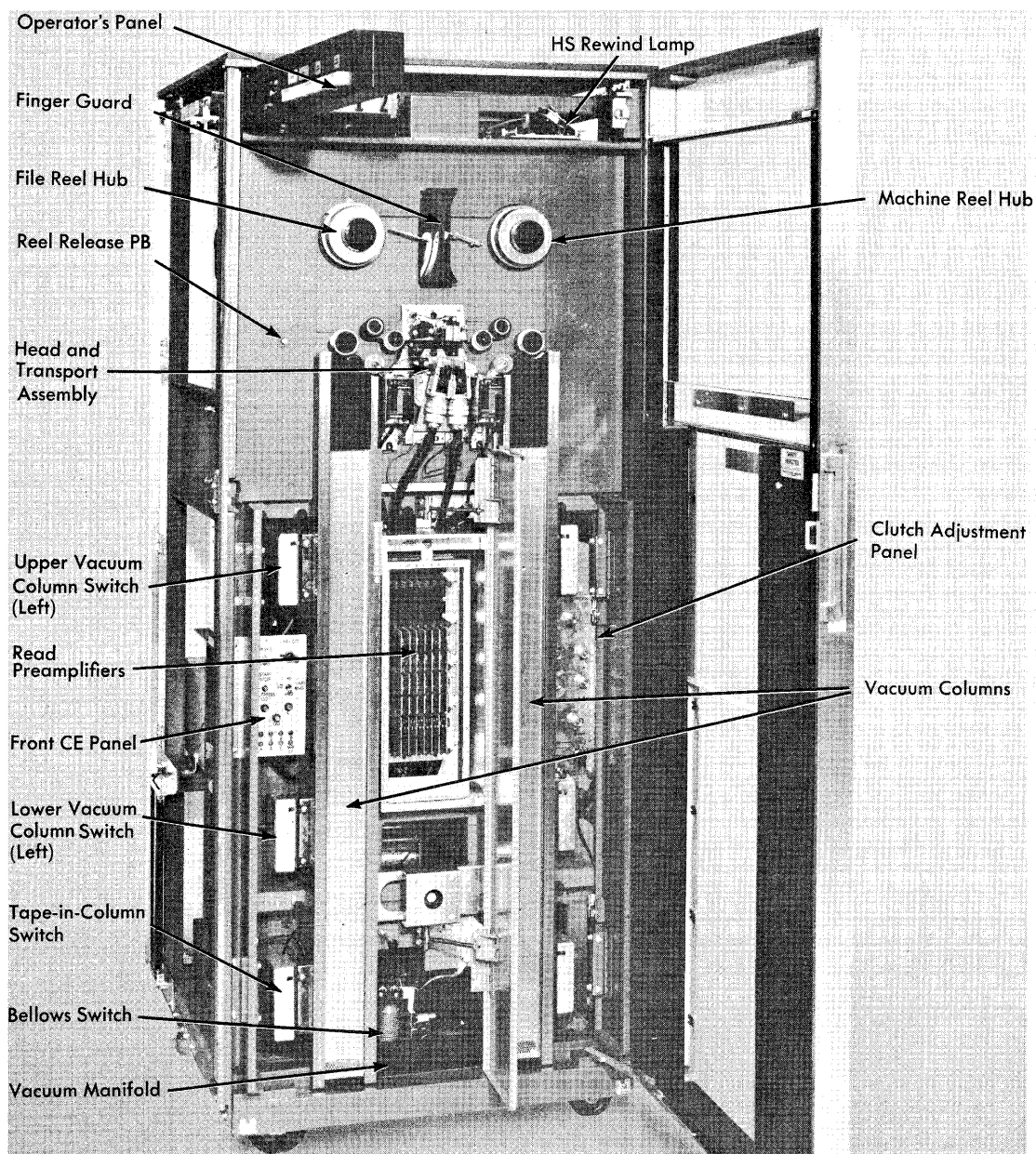

Figure 17. Tape Unit, Front

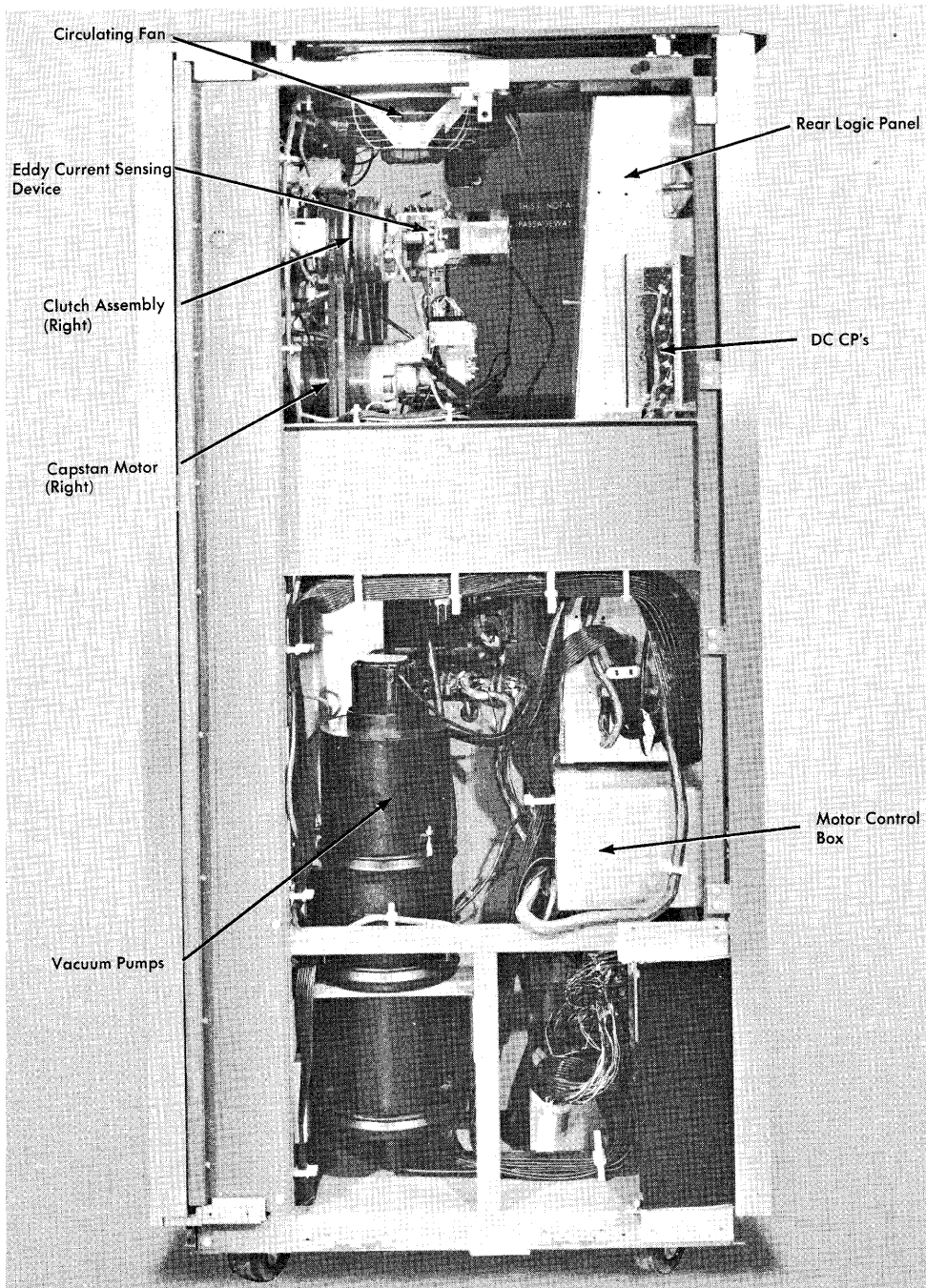

Figure 18. Tape Unit, Right Side

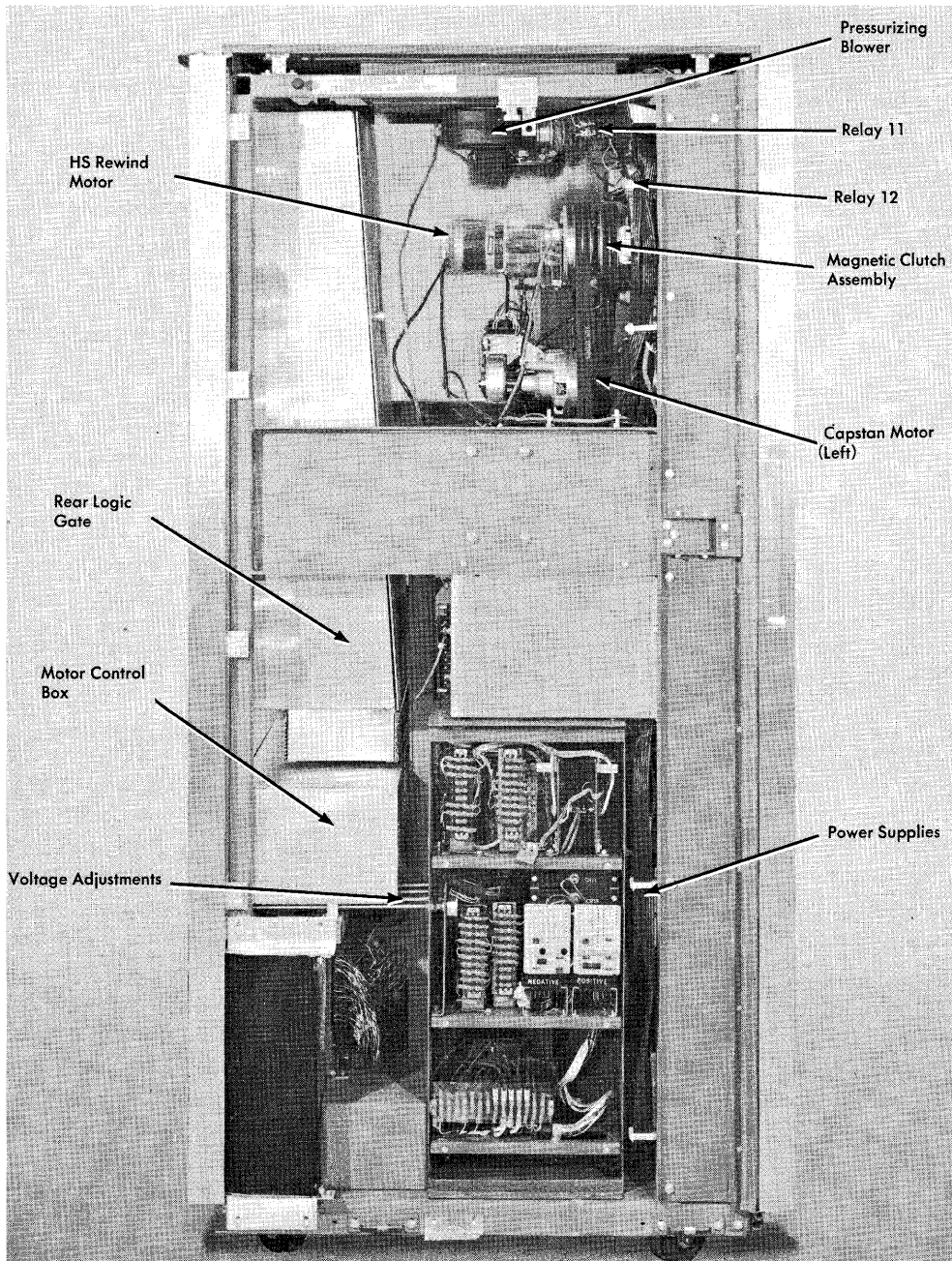

Figure 19. Tape Unit, Left Side

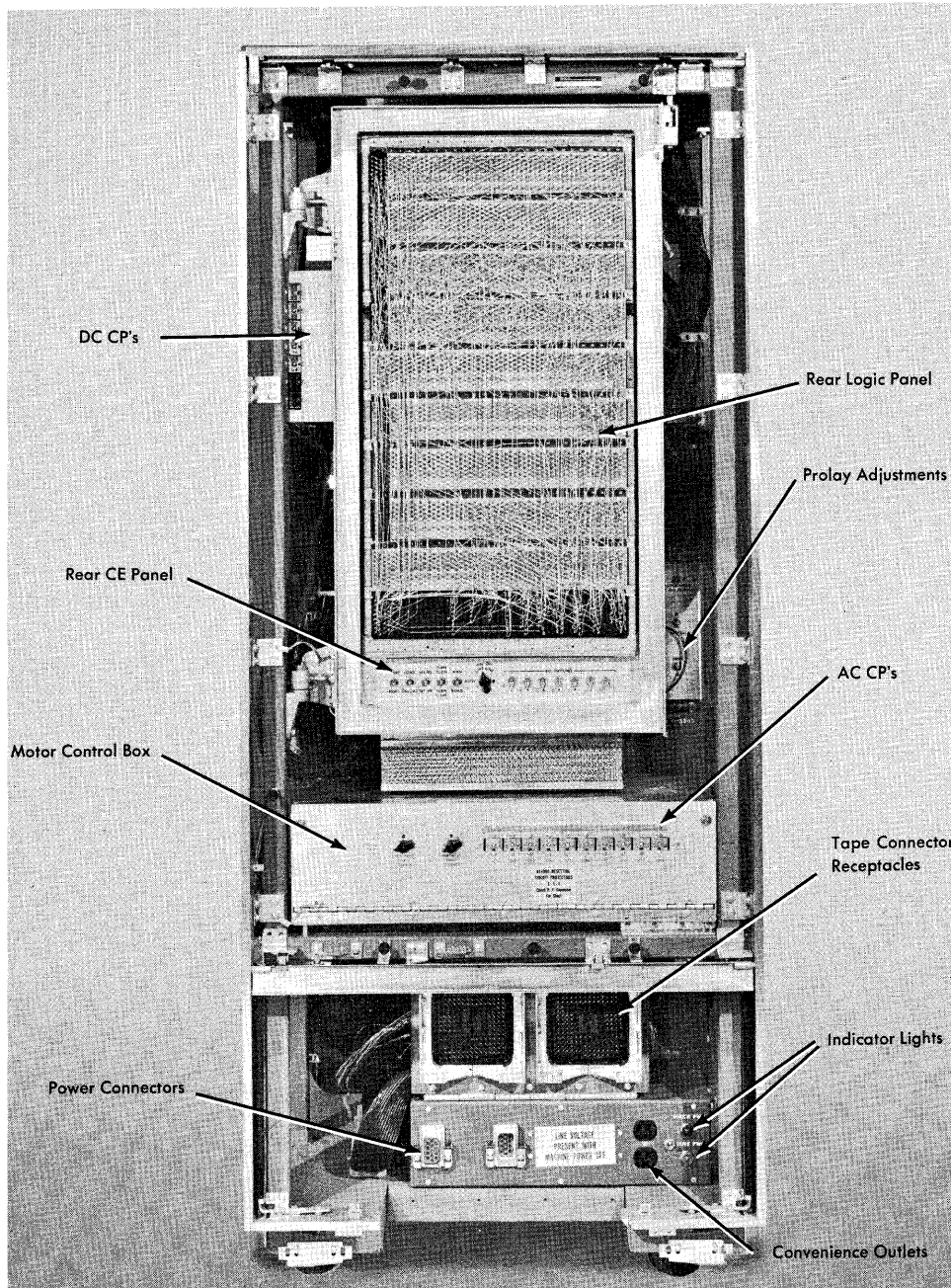

Figure 20. Tape Unit, Rear

The rear logic panel gate (Figure 7) is hinged to the back right post and contains the NOR logic, SMS cards, and associated wiring. The lower area of the gate contains the CE panel switches. Mounted under the gate are two small blowers to provide air circulation within the circuit panel. The DC circuit protectors (CP's) are mounted to the hinged side of the panel gate.

The lower area contains the main power, convenience outlet, I-O shoe receptacles, and power switches and lights. Mounted above this is the motor control box (Figure 32), which contains the necessary ACCP's, relays, clutch filters, resistors, capacitors, and terminal block connections. Immediately behind this box is the AC raceway, which provides pluggable power to the drive motors.

## Head Assembly (Figures 21, 22)

### General Description

The head assembly is constructed on two castings or plates. The lower plate is stationary, and the upper plate moves up and down under power. The two-gap read-write head, the tape break light, and the tape cleaner are on the lower plate. The load point and end-of-reel photocell assemblies, split guides, head shield, and erase head are on the upper plate. The shield prevents interaction between the read and write sections of the two-gap head.

The upper plate swings upward from the lower plate to allow threading of tape when the tape unit is in an unload status and to provide free movement of tape during high-speed rewind. When tape is transported through the machine for reading or writing, the upper plate is down, and the tape is held in close contact with the read-write head. The upper plate assembly is swung open and closed by a worm drive, which is belt driven from a motor at the rear of the clutch frame. When the upper plate of the head assembly is fully closed, positive locking is provided. Two micro-switches sense the status of the head assembly. Connections to the read-write head assembly, photocells, lights, etc., are made through three multipin connectors.

### VISUAL INSPECTION AND OPERATIONAL CHECK

Figure 23 shows the basic differences between the head assemblies for the IBM 729 II and 729 IV Magnetic Tape Units.

Inspect the head for uneven wear, scratches, nicks, and oxide build-up. Check for loose cable connections.

Check head up-down limit switches by performing tape load and unload operations.

Measure the read coil output of each track with the tape unit in a write operation. This output should be 15 to 30 millivolts, peak-to-peak, with each pulse width less than 20  $\mu$ s. Pulse symmetry of all seven pulses must be similar, and amplitude difference must not exceed  $\pm 5\%$ .

### CLEANING

Clean the tape unit transport mechanism at least once every 8 hours or after every ten full reel passes, whichever occurs first.

Cleaning materials required are: Cleaning applicator, typewriter brush, clean lint-free cloth, and IBM Tape Developer Medium and Tape Transport Cleaner, P/N 517960. Do not use Vythene IBM Cleaning Fluid, P/N 450608.

#### CAUTION

When cleaning the transport area, do not allow the tape transport cleaner to come into contact with the magnetic tape.

The cleaning fluid should never be in contact with the user's skin. To facilitate cleaning, use the cleaning applicator furnished with the tape cleaner kit. Use this procedure on all parts that are cleaned with the transport cleaner.

#### DANGER

Observe caution whenever the transport cleaner, P/N 517960, is used; be familiar with CEM 1203-76, or GP General CEM 24.

### LUBRICATION

Apply IBM 20 grease to the worm gear assembly used to drive the head assembly up and down.

Use IBM 6 lubricant on all pivot points and felt pads.

### ADJUSTMENT, HEAD LIMIT SWITCHES

Close the head and lock. Set the head down-limit switch so that the normally open contacts just transfer and make contact. This is accomplished with the switch bracket adjusting screw.

Turn the adjusting screw one-half turn counterclockwise, to insure switching transfer just before reaching the lower limit of travel.

With a 0.030  $\pm$  0.10 inch shim between the gear segment and stop spring, open the assembly to its full open position. Now, set upper limit switch so that the wired normally open contacts just transfer. Do this by loosening the switch mounting screw and nut, and rotating the switch.

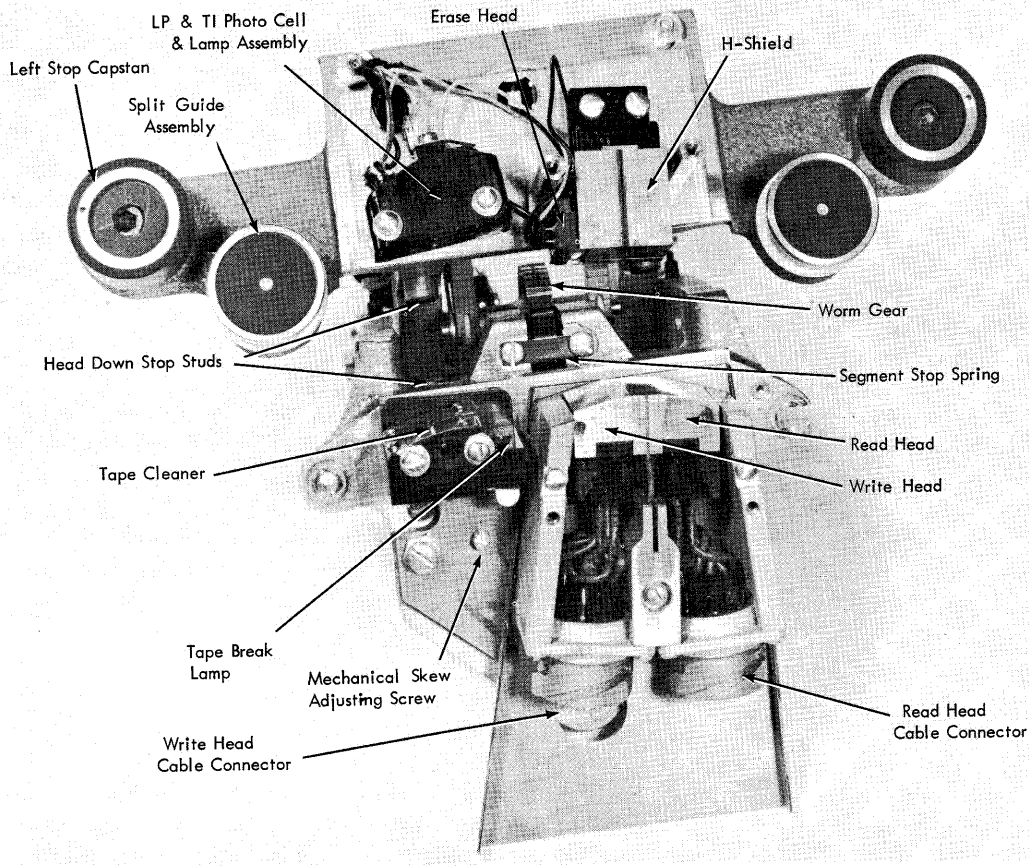

Figure 21. Head Assembly, Front View

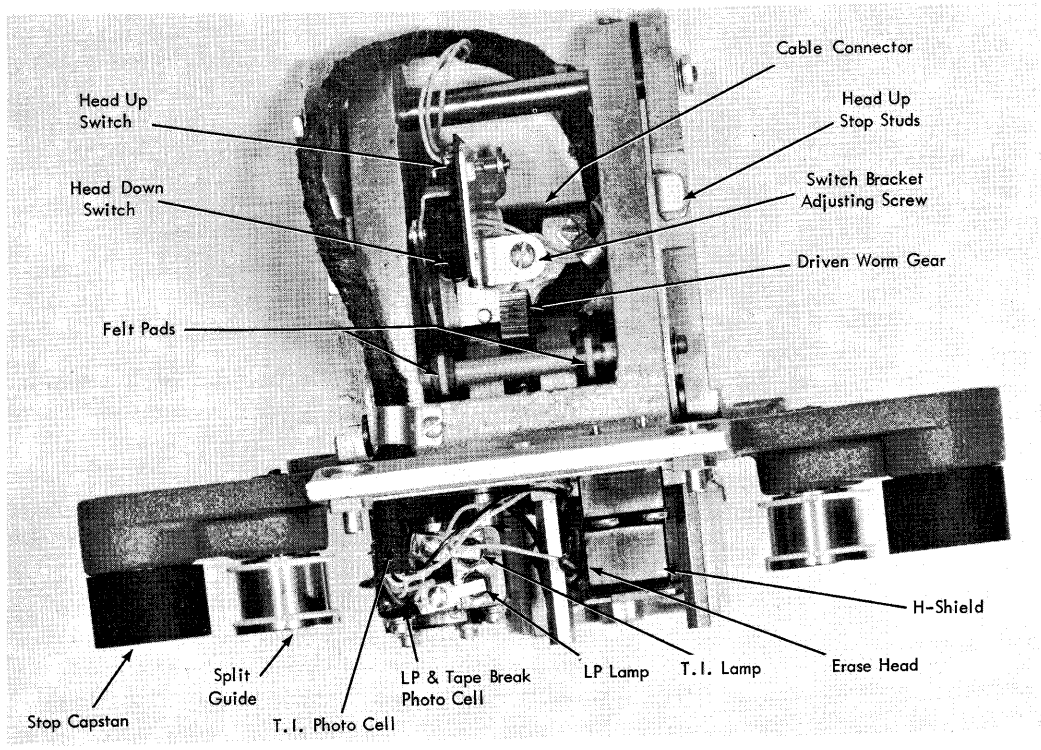
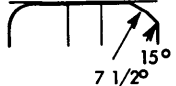
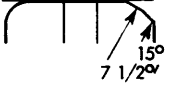

Figure 22. Head Assembly, Top View



HEAD COMPARISON CHART		
Type Head	729 II Two Gap	729 IV Two Gap
1. Head Configuration		
2. Write Gap (inches)	.0005	.0005
3. Read Gap (inches)	.00025	.00025
4. Write Track (inches)	.048	.048
5. Read Track (inches)	.030	.030
6. Materials in Contact with Tape	+Hy-Mu 80, phos. bronze, Havar *, epoxy	Hy-Mu 80, phos. bronze, Havar, epoxy
7. Write Turns	100 turns C.T. #42	100 turns C.T. #42
8. Read Turns	180 turns #42	120 turns #42
9. Write Current (ma)	70 ma	70 ma
10. Output	15-30 mv	15-30 mv
11. Tape Speed	75 ips	112.5 ips
12. Recording Density	200 bpi (15 kc) 555.5 bpi (41.7 kc)	200 bpi (22.5 kc) 555.5 bpi (62.5 kc)
13. Intertrack Shielding	Write (2) .0075 phos. bronze and 3 pcs. .002 Hy-Mu 80 sandwiched	Write (2) .0075 phos bronze and 3 psc. .002 Hy-Mu 80 sandwiched
14. Track Pitch	.070	.070
15. Dist Between Gaps (inches)	.300	.300

+ Trademark of Carpenter Steel Corp.  
\* Trademark of Hamilton Watch Co.

Figure 23. Head Comparison Chart

#### REMOVAL, HEAD ASSEMBLY

Remove upper and lower decorative head covers. Pull the upper cover forward and upward. Remove the two screws from lower cover.

Remove the inner cover from read-write head. Unplug head cables.

Remove the three nuts and flat washers that hold the assembly to the tape frame casting. Pull forward to remove the complete assembly.

#### **DANGER**

The upper head, if it is up, will snap shut from its own weight when the head assembly is disengaged from the jackshaft assembly and is pulled forward.

#### REPLACEMENT

Replacement procedures are the reverse of removal procedures except as follows.

#### **CAUTION**

Do not attempt to replace *any part* of the head assembly. The head must be replaced as a complete assembly.

1. When replacing the head assembly, keep it in the unlatched position to make replacement easier.

2. Be sure to line up the key in the head socket with the keyway in the plug. The key is located in rear of the head socket. Push up on the plug and turn the connector ring clockwise.

3. Make sure that head casting is seated evenly on the tape frame casting mounting studs before tightening the mounting nuts.

4. Check skew for mechanical alignment of head; check track C with track 1 only. Do not make any skew adjustments until you are sure that the head assembly is correctly and evenly installed.

Before a skew adjustment is made, the head locking screw must be loosened to remove slack in the skew adjusting screw. After the adjustment is made, tighten the head locking screw until it seats against the lower casting and all the slack is removed from the adjusting screw. Recheck skew adjustment for proper tolerance after tightening the head locking screw.

The complete skew adjustment procedure is described in the Skew section.

### Two-Gap Read-Write Head

The two-gap head used in the IBM 729 II and IV tape units contains seven adjacent write heads in laminated form (Figure 24). The assembly also contains seven read heads. The two groups of heads are positioned so that the gap in the write heads is 0.3 inch to the left of the gap in the read heads. Tape passes over the head assembly, oxide side down, to complete the flux path of the write and read heads. Separate writing and reading heads permit reading of a record for checking while it is being written.

An erase head mounted on the upper head plate assembly is used during writing. Writing automatically eliminates the old information, but the erase head,

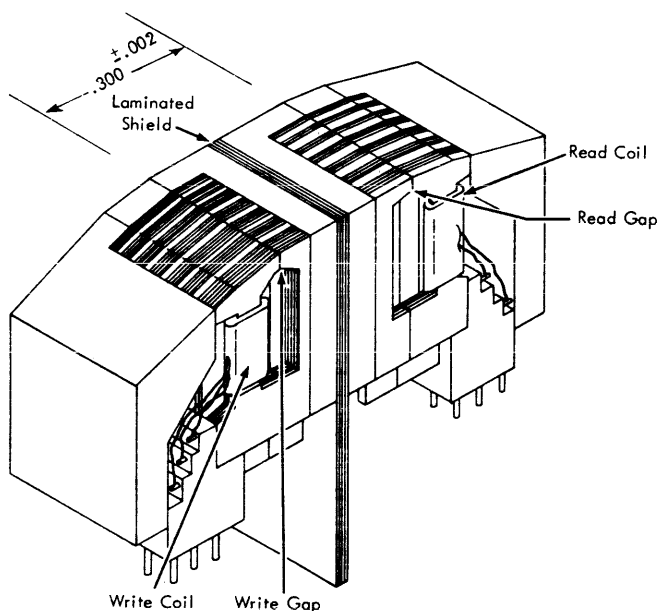

Figure 24. Two-Gap Read-Write Head

with its greater erasing power and extended coverage across the complete face of the tape, provides higher reliability in over-all tape operations.

To provide for interchangeability of tape between tape units using the two-gap head, the read head must read a track that is narrower than the write track. The width of the write track is 0.048 inch; the read track is only 0.030 inch wide; a safety factor of 0.009 inch exists on each side of the read track. As shown in Figure 25, there is no chance of reading an old record, even if the new record is written so that a portion of the old record is not erased.

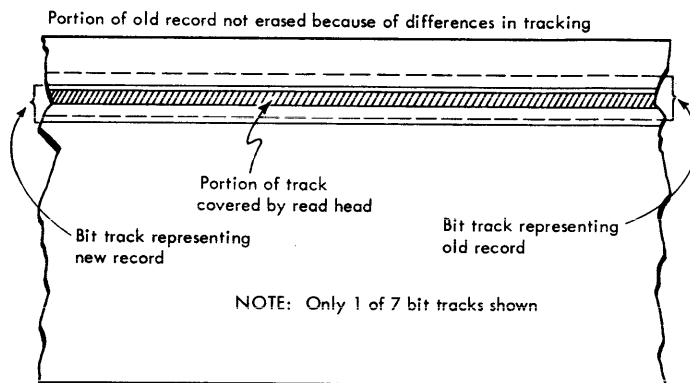

Figure 25. Write-Wide, Read-Narrow Concept

### VISUAL INSPECTION AND OPERATIONAL CHECK

Inspect surfaces for pits, scratches, tarnish, and uneven wear. Uneven or worn surfaces provide poor tape contact and cause low signal strength, resulting in read-write errors. Passage of tape across the head causes physical wearing of the assembly. This trenching of the head surface can be recognized by:

1. Excessive fluttering of the I and C bit bus signals.
2. Buildup of shoulders (trenching) on the head. These are visible in bad cases, but can be felt with the fingernail in almost all cases.
3. Unexplained increase in tape checks. This will probably be one of the first symptoms.

The decision to replace a worn head is left to the customer engineer, who is in the best position to decide in an individual case. It is emphasized, however, that the head assembly is an expensive part. Replace only heads that actually cause excessive errors. Always replace the entire head assembly when head replacement is indicated.

### CLEANING

Use silver polish to clean tarnished heads. Follow this polishing by cleaning the entire head, transport unit,

and vacuum columns thoroughly with tape cleaner. In cleaning the head, always wipe it in the direction of tape movement. Make sure the head is clean before performing skew and preamplifier adjustments. Amplitude can increase 10 to 40 per cent as oxide builds up on the head. When cleaning the head, also clean the underside of the ceramic guide with a typewriter brush.

#### REMOVAL AND REPLACEMENT

For removal and replacement of the read-write head see "Head Assembly." The read-write head assembly should be replaced when:

1. Output is out of specifications (amplitude and skew).
2. The head is worn (trenched).

#### H Shield Feed-Through

Feed-through is signal pick-up on the read head from the write tracks when the tape unit is in write status.

#### ADJUSTMENT

The H shield should be adjusted for minimum feed-through as follows:

1. Unplug the right capstan motor and manually extend the capstan.
2. Write ones on all tracks from the CE panel.
3. Observe the signal on the read bus.
4. Adjust the H shield for minimum feed-through signal on all channels.
5. Feed-through specifications for 729 II and IV are  $\leq 0.4v$  peak to peak.
6. When a tape unit is adjusted for minimum feed-through, excessive temporary write checks may occur because of the position of the H shield. If the center of the H shield is located to the left of the center laminations of the head (Figure 26), extra bits can be introduced into TAU register B. This shows up as a bit pickup and gives a compare error, causing the temporary write check. To correct this condition, the H

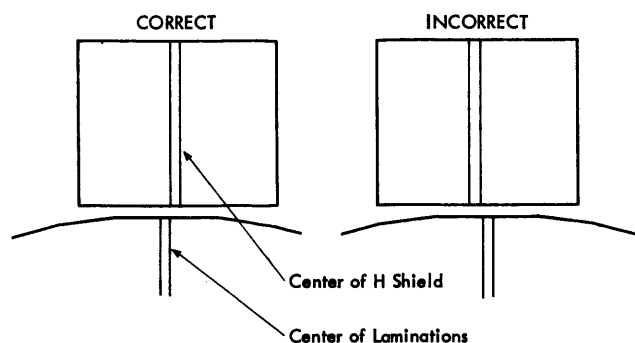

Figure 26. H-Shield Adjustment

shield should be moved to the right, so that the center of the H shield is to the right of the center head laminations. This must be done even though minimum feed-through is sacrificed.

#### CLEANING

The underside of the H feed-through shield should be cleaned with a typewriter brush.

#### Erase Head

Theoretically, an erase head is not necessary, because old information is automatically erased by the writing of new information; an erase head is provided, however, to reduce the possibility of bits being left in an inter-record gap or skip area. Because of its wider coverage and stronger force, the erase head more completely erases areas of tape that have been lifted slightly from the head by foreign particles or air bubbles trapped between the tape and head.

#### ADJUSTMENT

Remove the H shield from the head assembly and position the brass mounting bracket as far to the left as possible.

With the head and guide assembly closed, and with tape out of the transport area, place a 0.005 inch shim across the cleaner block and head. Lower the erase head until it comes in contact with the shim. At the same time, position the head to the extreme left and clockwise about its mounting screw.

This shim will locate the erase head 0.003 (+0.001, -0.000) inch above the tape. The shim must be straight to follow the line of tape movement. Do not force the head down on the shim; this could cause the shim to deflect and produce an incorrect adjustment.

#### Skew

Even though the tape transport and read-write assemblies are assembled with the utmost precision (to .0001 inch in some cases) it is almost impossible to cause all bits of a character to be written or read simultaneously across the face of the magnetic tape. In some cases, there is a time difference between the recognition of the various bits. This condition is called skew.

Skew can result from both mechanical and electrical factors. If the seven read-write heads are not mounted exactly perpendicular to the magnetic tape motion, the character will be written at an angle across the tape instead of at exactly 90° to the edge (Figure 27).

If skew becomes too great (especially where high densities are used) there can be an overlapping of characters, resulting in tape errors.

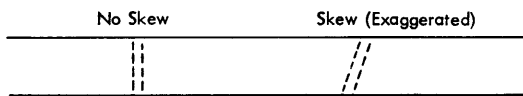

Figure 27. Tape Skew

Electrical wires and electronic circuits have inherent delays. As a result, the various bits of a character may be separated timewise between the instant they are read and the time they are received by the controlling unit. If these delays are excessive, tape errors will result.

Mechanical and electrical adjustments are provided to compensate for skew.

#### OPERATIONAL CHECK AND ADJUSTMENT

Check skew adjustments every 13 weeks or more often if indicated by poor machine performance. Skew must be adjusted whenever any parts are changed in the transport area. These parts include nylon idlers, forked arms, and prolays.

An operational or adjustment check is required when the combined skew of a tape unit and its associated final amplifiers, reading or writing all bits, exceeds  $2.3 \mu\text{s}$  on a 729 II or  $1.5 \mu\text{s}$  on a 729 IV. Before starting the check:

1. Correctly adjust the prolays.
2. Clean the tape transport, capstans, nylon pulleys, rewind idlers, ceramic guides, tape cleaner blade, and read-write head, using a lint-free cloth and approved cleaning solution.
3. Calibrate the oscilloscope.
4. Compensate the oscilloscope probes.

#### MEASUREMENT TECHNIQUE

When checking or adjusting skew on the read bus, observe the following:

1. Use the maximum vertical gain possible on the oscilloscope; if necessary, use direct probes.
2. To display small amounts of skew more easily, use the vertical position control to pass one oscilloscope trace through the other.
3. When using master tape, use a full pass to insure even wear throughout.
4. Adjust skew while scoping the read bus. This should be done at this point for two reasons:
  - a. The possibility of adjusting the tape unit to compensate for delay in the final amplifiers in the data channel or synchronizer is eliminated. Such a condition could produce compatibility problems, both in written data on tapes and between tape units and channels.
  - b. System time required to set skew is minimized or eliminated.

#### ADJUSTMENT, MECHANICAL SKEW

1. Mount master skew tape 556 BPI, P/N 461096 (replaces P/N 460680).
2. Return all read delays to zero. (This is omitted if checking only.)
3. Check that all preamplifier outputs are equal. The amplitude will depend on the condition of the master tape. Adjust if necessary. When adjusting skew using Tektronix 310 oscilloscope and 60 c/s chopper, reset the amplitude of the reference track after final checking.
4. Connect an oscilloscope and check 1 and C bits, synchronizing on either one.
5. Loosen the head locking screw and adjust the vernier screw for coincidence of the 1 and C bits. Make sure that 1 and C bits being scoped are both in the same character. This may be done by comparing A and 4, B and 2, C and 1.
6. Tighten the head locking screw and recheck to be sure that the adjustment has not changed.

#### ADJUSTMENT, READ SKEW

Proper mechanical skew is a prerequisite. Read skew is always checked or adjusted before write skew.

To adjust read skew:

1. Using the master skew tape, return all read delays to zero.
2. Check preamplifier outputs as in step 3 of the mechanical skew adjustment procedure.
3. Determine which track is lagging most (last bit) and synchronize the oscilloscope on this track.
4. Adjust the read delays for optimum coincidence with the most lagging track. The most lagging track must occur within  $2.3 \mu\text{s}$  (of the leading track) on 729 II units, and within  $1.5 \mu\text{s}$  on 729 IV units.

#### ADJUSTMENT, WRITE SKEW

Proper read skew is a prerequisite. To adjust write skew:

1. Mount a reel of tape known to give good performance.
2. Return all write delays to zero (not necessary if performing only operational check).
3. Write ones on all tracks, at high density.
4. Connect the oscilloscope to the read bus and observe all tracks.
5. Determine the most lagging track (last bit) and synchronize on it.
6. Adjust the write delays so that all tracks coincide with the most lagging track.
7. Reset write triggers after moving taps, to insure that all tracks are being written in phase.

#### OPERATIONAL CHECK OF SKEW

Skew can be checked either on the read bus or at the output of the read register in TAU or the data synchronizer. When checking skew, always use ones written on all tracks; random information should not be used.

For measurement only, the read register output may be the most convenient point to observe because it will display a sharp pulse waveform.

When skew is thought to be within the final amplifier, the following checking procedure can be used: Feed *one* track from the tape unit to the suspected track and to another that is considered correct (jumper the two final amplifier inputs together). Two tracks can be jumpered together at the edge connectors on the preamplifier panel in the tape unit.

#### Write Current

The check for correct write current is made by observing the voltage drop across the resistors in the collector circuit of the output in each of the 14 head drivers. The procedure described here is for an off-line, static condition. A typical waveform is shown in Figure 28.

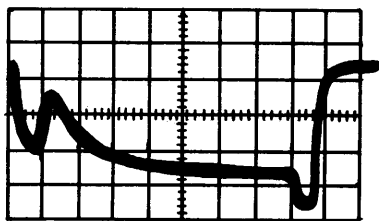

Writing continuous 1's  
5v/cm 2 $\mu$ s/cm  
DC input  
Internal sync

Figure 28. Write Current Waveform

#### ADJUSTMENT

There must be 70 ma (+1.2, -9.9), steady state, passing through one of the write coils of each track when writing continuous ones. The checking procedure is:

1. Load the tape unit with a test tape and set the unit to write status, writing continuous zeros in the track being checked. Use the CE panel for control purposes. The tape need not be moving.

2. Compensate the probe and calibrate the scope, using approved procedures.

#### DANGER

Do not float the scope.

3. Ground the scope at electrical ground of the card being checked and probe the voltage across the resistors in the output of the head driver circuit.

4. Adjust the scope to line up the voltage trace with the center graduation on the face of the scope.

5. Check the voltage trace on the face of the scope relative to the reference graduation line selected in step 4. If write current is flowing through the write coil, the voltage drop across these resistors will be approximately 15 volts. If no voltage drop is observed, tweak the opposite half of the driver circuit with a -6 volts at the cross couple input, and repeat steps 3, 4, and 5. If the voltage drop and the value observed are outside the specified values, check through for causes, such as maladjusted or no -6 volts power supply or faulty components in the head driver circuitry. (Faulty components can be located by substituting new cards.) If the read-write head must be replaced, follow the procedures outlined in the Head Assembly section. Skew must be checked and readjusted if the head is moved.

6. Repeat steps 3, 4, and 5 for the remaining head driver circuits.

#### Split Guide Assembly

Two split guides (Figure 29) maintain proper alignment of the tape as it passes over the read-write head. They are located on the upper head plate to the right and left of the head assembly. The split guides keep the tape parallel (at a fixed distance) to the front casting. Alignment between machines can be closely controlled. To avoid complex systems, alignment is maintained only to one edge of the tape. The stationary part of the guide holds the front edge of the tape at a fixed distance from the front casting. The rear portion of the guide is free to slide on the shaft and is held in continual contact with the rear edge of the tape by three spring loaded plungers which protrude from the upper head assembly casting.

When the tape expands in width, it spreads the split guide. The track farthest away from the front edge of the tape is most subject to misalignment when the tape expands or contracts laterally between the time of recording and the time of reading.

The inner flange surfaces of the split guides are lined with a ceramic material that is highly resistant to wear from tape passing over the guide at high speed. The entire split guide assembly is permanently mounted; it does not rotate when tape passes over it.

#### VISUAL INSPECTION AND OPERATIONAL CHECK

Check the front and rear ceramic washers for cracks, chips, and dirt. Check for loose mounting screws and

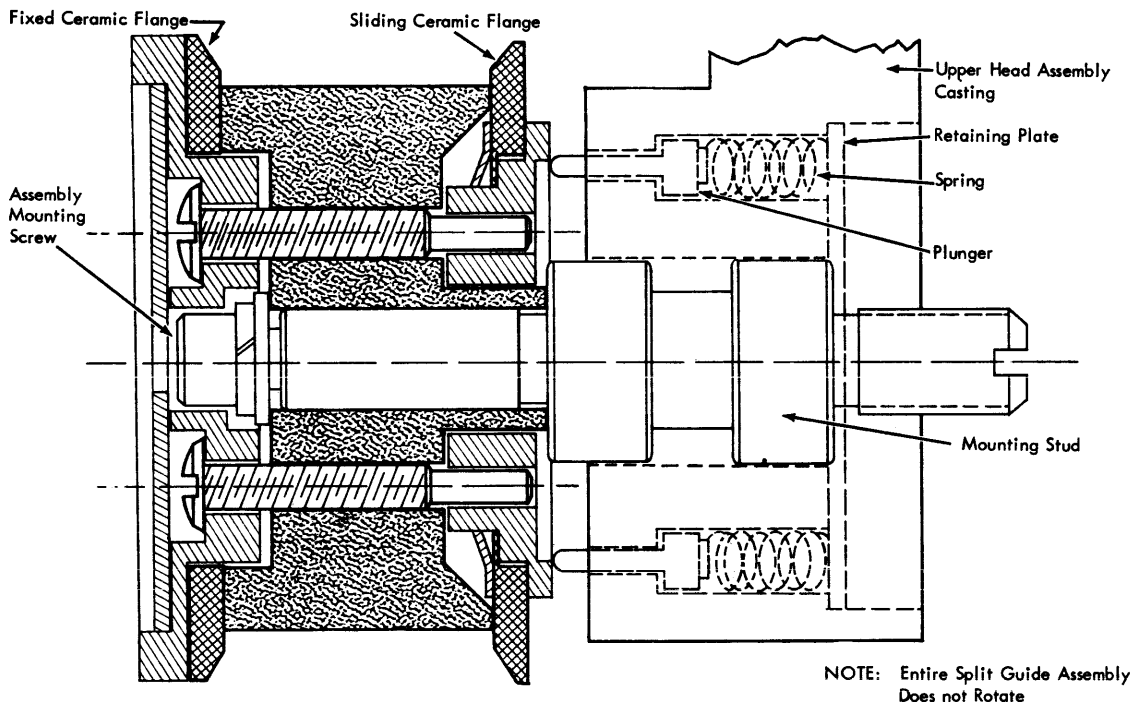

Figure 29. Split Guide Assembly

physical damage to the metallic surface over which the tape is transported.

#### CLEANING

Clean split guides with the cleaning applicator.

#### REMOVAL

The entire assembly is never removed from the head casting. Only the guide hub and ceramic washers are disassembled in the field. To remove the guide hub and ceramic washers:

1. Insert a 5/64-inch Allen wrench into the face of the guide hub.
2. Loosen the Allen screw and remove the hub.
3. If the assembly is removed for cleaning only, mark the relative position (with pencil or other marker) of the hub and ceramic washers.

#### REPLACEMENT

Replace the hub and ceramic washers by reversing the removal procedure. Be careful not to overtighten the center body screw, because it may break.

#### CAUTION

Never tamper with Glyptal\* cement covering the guide mounting stud on the back side of the head assembly casting. Disturbance of the guide mounting stud alters tape alignment and affects skew.

### Tape Cleaner Blades (Figure 21)

#### VISUAL INSPECTION AND OPERATIONAL CHECK

The tape cleaner blade is mounted on a phenolic block on the left side of the read-write head. Remove the top cover by pulling it forward and visually inspect for signs of physical damage and excessive oxide build-up on the cleaner blade.

#### CLEANING

Use the cleaning applicator moistened with IBM Tape Developer Medium and Tape Transport Cleaner, P/N 517960. Do not rub hard on the cleaner block.

#### CAUTION

Do not allow the tape transport cleaner to come in contact with the magnetic tape.

#### REPLACEMENT

Replace the tape cleaner blade if it is damaged; four screws hold the blade to the phenolic block. The tape should not contact the leading or trailing edge of the cleaner blade.

#### ADJUSTMENT

The approach angle of tape to the head is set at the factory for an angle of  $7\frac{1}{2}^\circ$ . An approach angle of less

\*Trademark of General Electric Company.

than  $7^\circ$  can trap an air bubble, causing a loss in contact between tape and head surface. An air bubble can also be produced by a wrap angle of greater than  $7^\circ$ ; this usually becomes apparent at about  $10^\circ$ , but this bubble is generally less pronounced. A wrap angle of more than  $7\frac{1}{2}^\circ$  is undesirable, however, because it allows more head-to-tape contact and thus more oxide build-up.

*Check the Wrap Angle* as follows:

1. Apply silver polish (Gorham's or International Silver Polish is preferred) to the entire head surface sparingly; allow the polish to dry, forming a white powder.

2. Load a work tape (not intended for processing) and run continuously forward until there is about  $1\frac{1}{2}$  radial inches of tape on the machine reel; then rewind.

3. Unload the tape unit and observe the head; the powder will be wiped off the head where the tape has contacted the surface. Visual inspection should show that the apex at point A (Figure 30) has been wiped completely clean, indicating a tape approach of just over  $7^\circ$ .

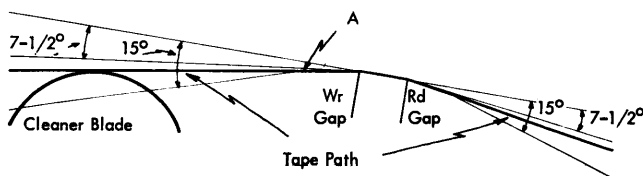

Figure 30. Tape Cleaner Wrap Angle

4. Clean the tape transport and columns thoroughly with tape transport cleaner to remove any polish that is deposited.

*Check for Air Bubbles* as follows: A normal start-stop setup is used, reading all bits. In extreme cases, the air bubble can be detected at the read head. It will show as a dip in the normal waveform envelope (Figure 44). The time from co depends on whether the angle is less than  $7\frac{1}{2}^\circ$  (largest exposure is here) or more than  $7\frac{1}{2}^\circ$ . (This angle has to be radically incorrect, to about  $10^\circ$ .) If the wrap angle is small, the dip in the envelope will appear about 7 ms to 8 ms from co. A large wrap angle will produce a dip about 12 ms from co.

Frequently, this loss in contact cannot be detected at the read head. The write head can be used to "read" the signal for detecting the bubble. Disconnect one or more tracks (three wires each) of the write head at the edge connectors in the logic gate. Observe the output of the opened write tracks on a scope. A direct probe—and possibly a high-gain preamplifier in the

scope—is necessary. The envelope will be similar to the usual start-stop envelope. A distinct decrease in amplitude, by as much as 50%, or even to zero, indicates loss in contact. A small wrap angle will produce a dip about 4 ms from co.

The read head should be used for detecting loss in contact when tape is moving backward.

Incorrect wrap angle can cause excessive read or write errors, and possibly bits in the  $\text{IR}$  gap. It is recommended that head assemblies causing such failures be replaced by a new assembly.

### Photosensing

Three photocells and four associated lights are located on the head assembly or in the immediate area. Light, either shining directly at or being reflected to the photocells indicates to the system specific physical tape conditions.

#### HIGH-SPEED REWIND PHOTOSENSING

A photocell and light are used to determine the type of rewind that the tape unit will do. The photocell is in the lower section of the finger guard (Figure 17). The light is on the right corner of the top plate; its beam is directed on the photocell. When more than  $\frac{1}{2}$  inch of tape is on the machine reel, the light path is blocked and tape rewind is at high speed (average—500 inches per second). When less than  $\frac{1}{2}$  inch of tape is on the machine reel, rewind is at low speed (normal tape speed: 729 II, 75 inches per second; 729 IV, 112.5 inches per second). During a high-speed rewind, when about  $\frac{1}{2}$  inch of tape remains on the machine reel, tape is allowed to coast to a stop. The tape is then lowered into the vacuum columns, and rewinding is completed at low speed.

#### LOAD-POINT PHOTOSENSING

The load point is a small reflective spot ( $\frac{3}{8}$  inch  $\times$  1 inch), placed on the plastic side of the tape ( $\frac{1}{2}$  inch from the front edge and 10 feet from the physical beginning of the tape). This reflective spot locates the beginning of the usable portion of the tape. The ten feet of tape preceding the spot is for threading the machine reel.

The load point reflective strip is used during a back-space or rewind operation. It is sensed by a photocell arrangement (Figure 31). Light from the front bulb is reflected from the spot to the photocell directly to the left of it.

#### END-OF-REEL PHOTOSENSING

The end of the usable portion of a reel of tape is indicated by a reflective spot about 18 feet from the end of the tape. This spot is placed on the plastic side of the

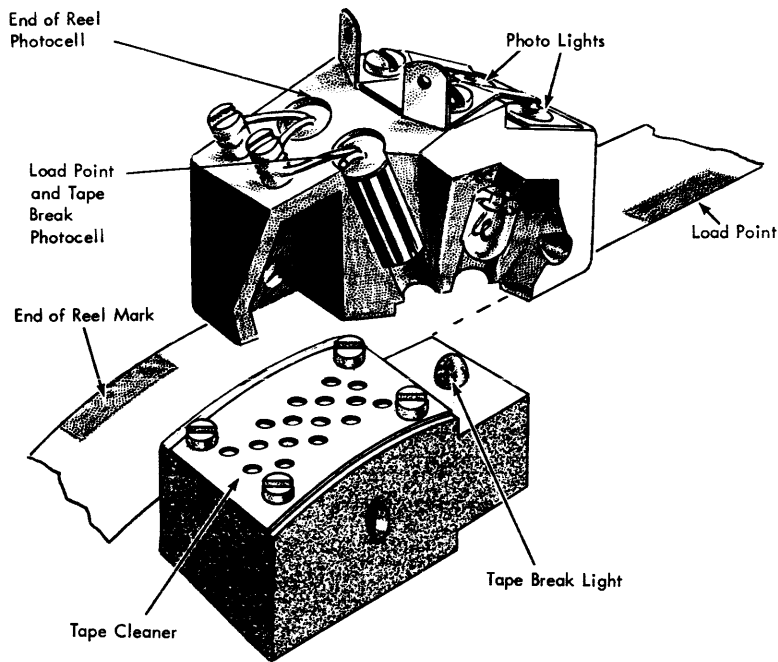

Figure 31. Photocell Sensing

tape  $\frac{1}{2}$  inch from the back edge. The photocell (Figure 31) senses this reflective spot. If the tape unit is in write status when the end-of-reel reflective spot is sensed, a tape indicator trigger is turned on. If the tape unit is in read status when the reflective spot is sensed, there is no indication.

#### TAPE BREAK PHOTSENSING

During a high-speed rewind operation, tape passes between a light source on the lower head plate (to the left of the read-write head) and the load-point photocell. If the tape breaks, light strikes the load-point photocell, causing the tape unit to stop.

#### VISUAL INSPECTION AND OPERATIONAL CHECK

Visually inspect the high-speed rewind, tape break, tape indicator, and load point lamps for equal brilliance. Inspect photocells for physical damage. Access to the high-speed rewind lamp is provided through the control panel door. The high-speed rewind photocell is accessible after removal of the plastic finger guard cover between the two tape reels. Load point and tape indicator lamps are located in the photosensing block in the upper head assembly. The tape break lamp is mounted in the tape cleaner block.

It is possible for the photosensing cable assembly to be worn by the plastic dust shield mounted on the 729 base. This occurs when the head is raised and the

cable assembly is pinched between the head and dust shield. This condition can be corrected by insuring that the cable clamp positions the cable out of the way.

To check the load point and tape indicator circuits, position two reflective spots on the tape about six inches apart and place tape unit in the write auto-cycle mode. The tape unit will reverse direction each time a reflective spot is sensed. The tape break circuit can be checked by placing masking tape over the high-speed rewind photocell and an opaque card across the read-write head and tape cleaner blade. After the file reel begins to rotate, remove the card. The file reel should stop.

#### **DANGER**

If the tape unit is placed in a high-speed rewind operation without a reel on the left side, the metal latch ring can fly off. When checking high-speed rewind circuitry, it is essential that a reel always be on the left side of the tape unit (with the hub tightened).

#### ADJUSTMENT, LOAD POINT, TAPE INDICATE, AND TAPE BREAK LAMPS

Adjust resistor 20 (Figure 32) with its sliding tap so that the voltage across the load point and tape indicate bulbs (with tape in the columns) is  $6.0 \pm 0.2$  volts.

Set resistor 21 for 8.5 volts across the tape break lamp.



**ADJUSTMENT, HIGH-SPEED REWIND LAMP**

Adjust resistor 19 with its sliding tap so that the voltage across the lamp is 4.0 (+1.0, -0.5) volts.

**REMOVAL, HIGH-SPEED REWIND LAMP**

1. Remove the plastic cover by loosening the retaining thumbscrews.
2. Remove the lamp from its socket.

**CAUTION**

Be careful not to damage lamp and socket; both are fragile.

**REMOVAL, HIGH-SPEED REWIND PHOTOCELL**

1. Snap open the finger guard by pulling forward and twisting.
2. Remove the retaining clip and screw.
3. Using long-nose pliers, unplug the photocell from its socket.

**REMOVAL, LOAD POINT AND TAPE INDICATE LAMPS**

1. Raise the head assembly.
2. Snap off the upper decorative cover.
3. Loosen the retaining spring and screw.
4. Rotate the retaining spring out of the way and remove the lamp.

**REMOVAL, LOAD POINT AND TAPE INDICATE PHOTOCELLS**

1. Raise head assembly.
2. Snap off the upper decorative cover.
3. Unsolder the leads and remove the photocells.

**REMOVAL, TAPE BREAK LAMP**

1. Remove the lower head decorative cover.
2. Loosen the lamp retaining spring and screw on the underside of the tape cleaner block.
3. Rotate the spring out of the way and catch the lamp as it falls from its position.

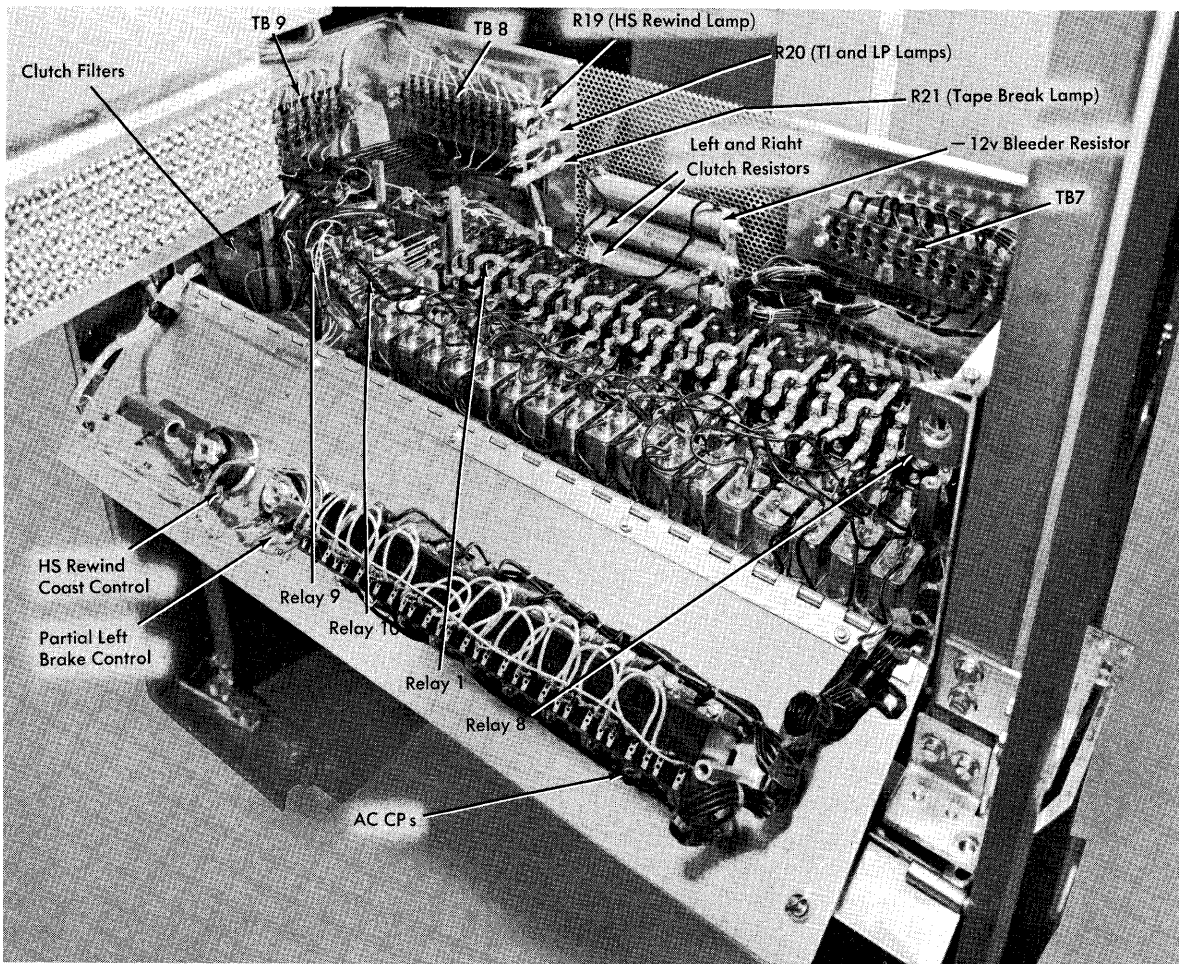

Figure 32. Motor Control Box

## Rewind Idlers

### VISUAL INSPECTION AND OPERATIONAL CHECK

Check for binds. The idlers must spin freely, without excessive end play.

### CLEANING

Clean with a lint-free cloth and the approved cleaning fluid. Carefully using a pen knife, remove all loose particles. (These particles result from the pressing of the idler on the shaft.)

### REMOVAL

1. Remove the capstan motor. See "Drive Capstans and Motors."
2. Remove two mounting screws.
3. Remove the rewind idler.

## Preamplifiers

### VISUAL INSPECTION AND OPERATIONAL CHECK

Periodically check preamplifier gain by scoping the read bus while writing on an average tape (10 to 100 pass usage). With a clean read-write head, the signal should be 8.8 volts peak-to-peak while writing in high density. See Figure 33. A standard signal level tape, P/N 461103 may be used, instead of the average tape just mentioned.

Visually inspect each potentiometer card for physical damage and damaged components.

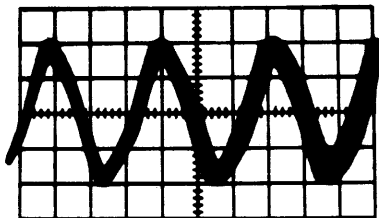

Read while writing continuous 1's  
Direct probe Centerline on 0v  
2v/cm 10ms/cm  
AC input  
Internal sync

Figure 33. Read Preamplifier Waveforms

### ADJUSTMENT

**NOTE:** Before adjusting preamplifiers, calibrate the scope, and compensate the scope probe or use a direct probe. Clean the read-write head and transport area.

In making the adjustment, use either the standard signal level tape, P/N 461103, or an average tape that has had 10 to 100 pass usage. A check using the standard signal level tape is a means of testing the condition of the average tape used for normal gain adjustment.

Set the gain to an average of 8.8 volts peak-to-peak while writing all ones in high density. Use a 1/4" Allen wrench to adjust the gain potentiometer on each of the seven amplifier cards.

Preamplifiers must be capable of producing a minimum of 10 volts output with the gain potentiometer adjusted for maximum.

Preamplifiers may break into a 600 kc oscillation with an amplitude of 1 to 2 volts, particularly on the last tape unit of a line of five. This oscillation should not cause trouble because it is not recognized by the final amplifiers.

### REMOVAL AND REPLACEMENT

Amplifier cards are accessible through the preamplifier door in the front of the machine. Cards are easily removed by pulling outward.

New cards are inserted into their receptacles as required. Different preamplifier cards are used in the 729 II and 729 IV. *These cards must not be interchanged.* Part numbers are: 729 II: P/N 370100 and 370099; 729 IV: P/N 371925 and 371926.

## Head Raising Mechanism

The mechanism that raises the upper plate of the head assembly is a worm gear driven from a friction clutch and toothed belt by a three-phase motor mounted on the rear of the magnetic clutch frame. See Figure 34.

When the head take-up motor is operated, the worm shaft turns, causing the upper plate to swing upward. When two phases are reversed and the motor is operated, the shaft turns in the opposite direction and lowers the upper plate of the head assembly.

### VISUAL INSPECTION AND OPERATIONAL CHECK

Check for binds by manually rotating the shaft through at least one complete revolution. To rotate the shaft:

1. Place the head in the unlatched position.
2. Release clutch tension by pushing down on the friction clutch disk.

### LUBRICATION

Lubricate with IBM 24 lubricant by placing a little oil on the fingers and running them along the shaft.

## Tape Movement

Tape is transported from the file reel past the read-write head to the machine reel by a drive capstan and prolay idler. It would be impossible to start and stop the tape efficiently under control of the reels because the reel drives are relatively sluggish.

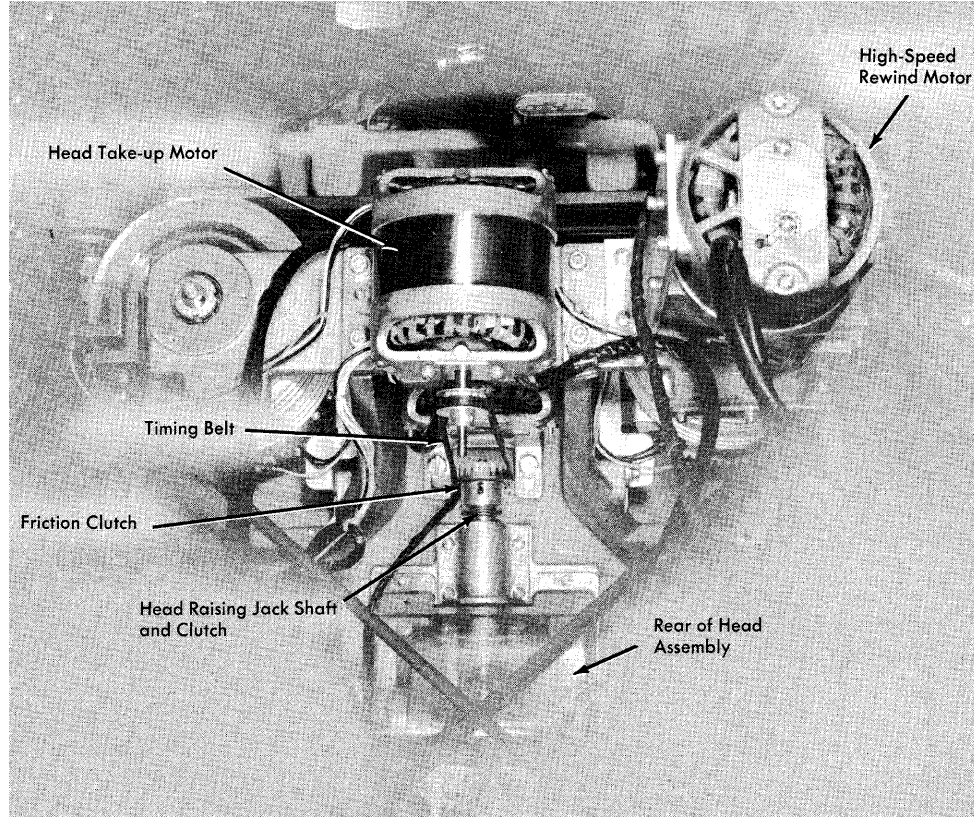

Figure 34. Head Raising Mechanism

Vacuum columns below the reels provide buffer storage areas. A loop of tape is retained in each of these columns. As tape is drawn from one column, it is replenished by the associated reel. As tape is pushed into the opposite column, the associated reel winds the tape. The control of reel motion and the reel drive is discussed later. Figure 35 shows the path of tape through the 729 tape unit.

**FORWARD**

The right and left drive capstans turn continuously in the direction shown. To move tape from left to right, the right prolay idler is pivoted to the right, squeezing the tape between the prolay idler and the right drive capstan. The left prolay idler is pivoted into a neutral position so it does not obstruct tape movement.

**BACKWARD**

To move tape from right to left, the left prolay idler is pivoted to the left, causing the tape to be squeezed between the prolay idler and the left drive capstan. The right prolay idler pivots to a neutral position.

**STOP**

To stop tape motion, the prolay idlers pivot toward the stop capstans, causing the tape to be squeezed between either the right or left prolay idler and the right or left stop capstan, respectively. If tape is being drawn from left to right (forward direction), it is stopped by the left stop capstan. If the tape is being drawn from right to left (reverse direction), it is stopped by the right stop capstan.

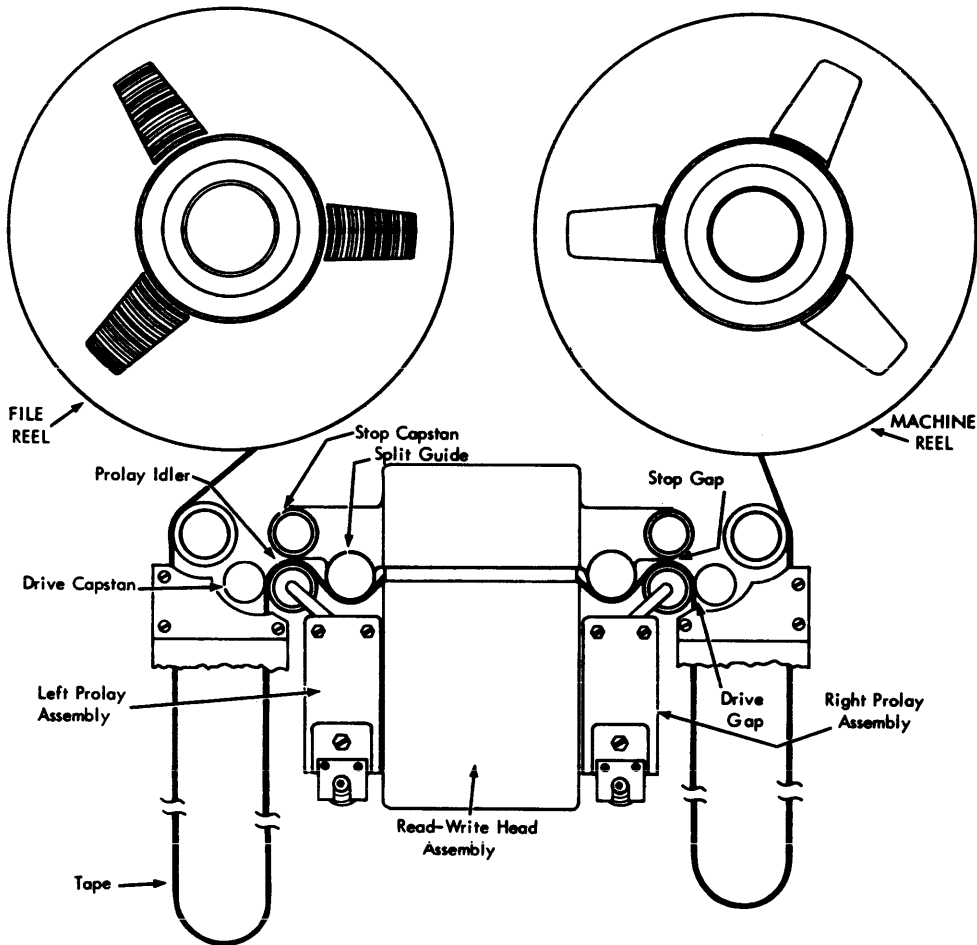

Figure 35. Path of Tape through Magnetic Tape Unit

### Prolay Assembly

Motion is imparted to the prolayers by a prolayers, which consists of three sets of electromagnets and an armature. The magnets are arranged so that the armature can assume one of three positions, depending on which set of magnets is energized. The motion of the prolayers armature is transferred to the prolayers idler and can cause it to move against the stop capstan or the drive capstan, or to a neutral position between the two capstans. Figure 36 shows a prolayers energized in stop status.

### OPERATION

The armature is pivoted (Figure 36) at the lower end of an arm. The prolayers idler is attached to the upper end of the arm. With this arrangement a movement of the prolayers armature will produce movement of the arm about its pivot point, causing the idler to change its position. Energizing the stop magnets moves the

prolayers armature to the right, causing counterclockwise movement of the arm about its pivot. This causes the prolayers idler to squeeze tape against the stop capstan.

When the neutral magnets are energized, the prolayers armature assumes a slanted position as shown in Figure 37. This causes the arm to be in a vertical position, placing the prolayers idler where it cannot contact either the drive capstan or the stop capstan. This is called neutral status.

Figure 38 shows the go magnets energized, causing the prolayers armature to move to the left while maintaining a vertical position. This produces clockwise movement of the arm about its pivot point, causing the prolayers idler to squeeze tape against the drive capstan.

The previous description covers operation of the right prolayers. Operation of the left prolayers is similar except that the prolayers arm is bent in the opposite direction and the positions of the stop and go magnets are reversed (Figure 39).

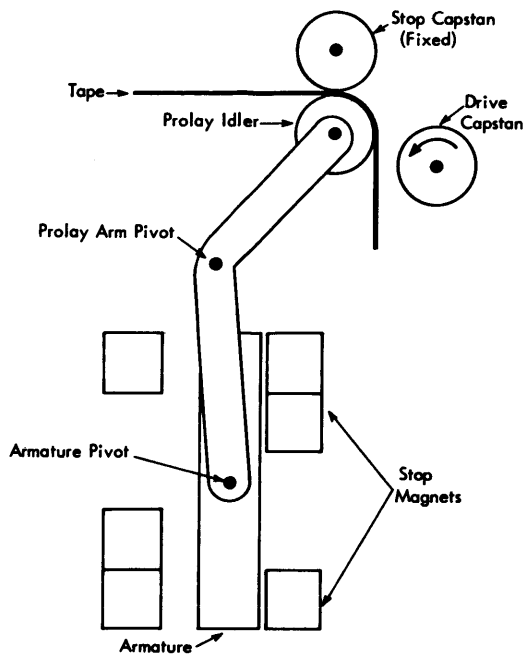

Figure 36. Right Prolay with Stop Magnets Energized

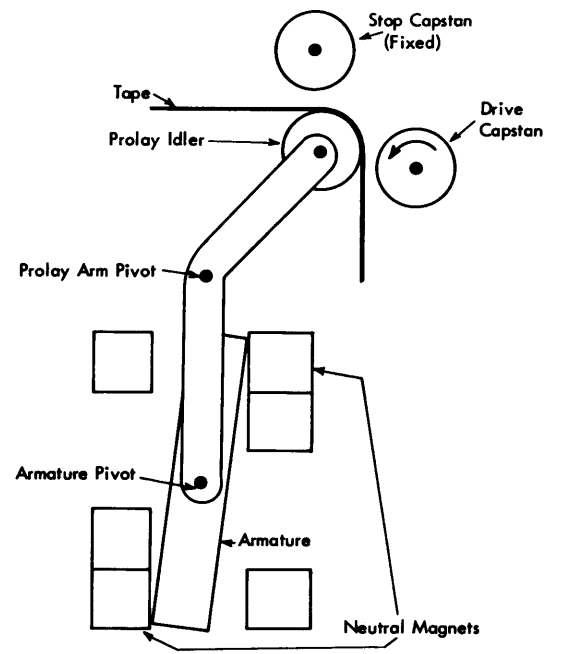

Figure 37. Right Prolay with Neutral Magnets Energized

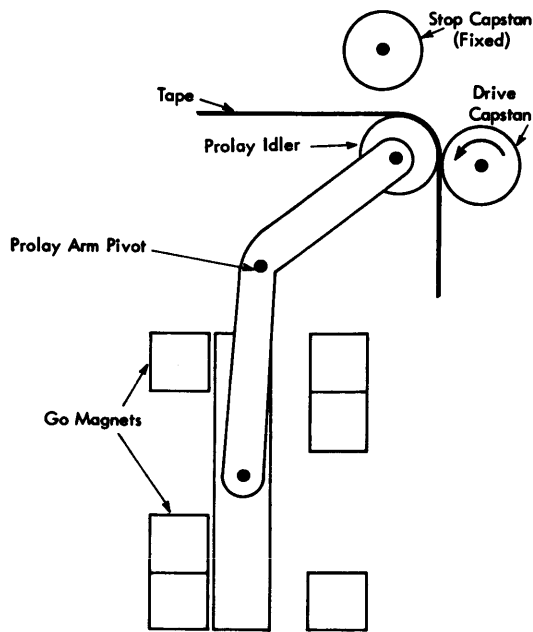

Figure 38. Right Prolay with go Magnets Energized

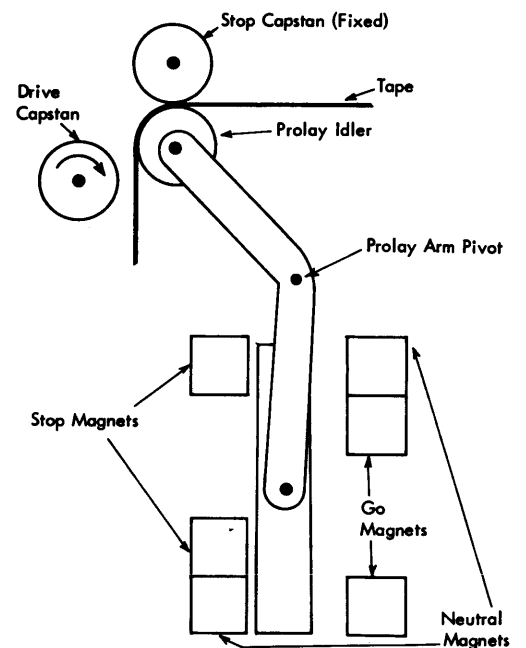



Figure 39. Left Prolay Showing Position of Magnets

## Prolay Specifications

Starting in December, 1960, prolays contain 0.003-inch shims on each side of the main casting, providing total shimming of 0.006 inch. See Figure 40. These prolays can be identified by a marking on the bottom of the prolay casting:

Unshimmed   
Shimmed 

Shimming the prolay has essentially increased the force available to penetrate the drive capstan. The higher force overcomes count five tendencies. (A count five condition is a very slow acceleration, after a 5-second or longer idle period, on prolays which may otherwise indicate a good start envelope on continuous start-stop.) All prolay information now refers to these shimmed prolays.

1. Drive and stop gaps should not be less than 0.003 inch.
2. The start envelope must not drop below 95% full amplitude after 7 ms (729 II) or 5 ms (729 IV). See Figure 41.
3. There should be no glitching (breaking of start envelope) of either the forward or backward start envelope.
4. Maximum noise burst following the stop envelope should not exceed five pulse cycles (ten peaks).

## Prolay Servicing

### CLEANING AND INSPECTION

Check frequently for dirty or burned nylon idlers; buff glazed drive capstans. Inspect and clean prolays whenever significant changes are indicated by inter-record

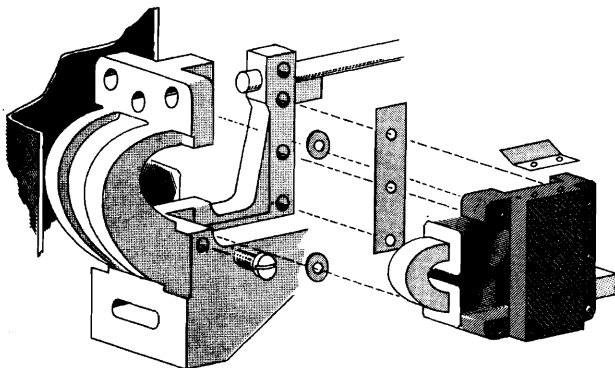

Figure 40. Shimmed Prolay

gap tests or whenever customer performance indicates possible prolay trouble. If any signs of wear or corrosion are evident on fork arm pivots or armature pivots after cleaning, the entire arm assembly should be replaced. All shafts must be clean; if they cannot be cleaned, replace them. After cleaning and inspection, check prolay start-stop wave forms.

When a nylon idler, fork arm or entire prolay assembly has been replaced, check mechanical skew (I and C tracks). If it varies from the original skew by more than 1  $\mu$ s, closely inspect the new nylon idler and replace it if the surface finish appears rough. A rough surface finish of the nylon idler can also cause a complete or partial collapse of the start envelope after 100% amplitude has been reached, usually 5 to 7 ms after CO is brought up. This condition will cause the envelope to closely resemble an "arrowhead," and usually indicates a rough idler on the left side. See Figure 44.

### LUBRICATION

Apply a thin film of Aeroshell 14 to the armature and forked arm pivots. Use a small amount of IBM 4 on the nylon idler shaft, taking care not to get the lubricant on the Mylar residuals or pole pieces. Any prolay assemblies that are chronically troublesome, even with this type of maintenance, should be replaced.

### ADJUSTMENT (FIGURES 42 AND 43)

Prerequisites to the adjustment procedure are clean, lubricated prolays and a clean transport. The tape unit must be loaded but not at load point.

#### CAUTION

Do not use tape that is intended for systems use (customer's tape).

With a prolay installed on the tape unit, adjust it as follows:

1. Adjust steady state current:
  - a. Drive current: adjust potentiometer for a 4-volt drop across TB 11-8 and 9.
  - b. Neutral current: adjust potentiometer for 3-volt drop across TB 11-6 and 7.

To adjust the steady state current through forward and reverse prolay drive coils, measure the voltage drop across the 2-ohm, 25-watt parallel resistors on TB 11-8 and 9 and adjust the 0.5-ohm, 50-watt potentiometer for a 4-volt indication (4 amperes), with the tape unit in a static condition (Figure 20). The terminal boards and potentiometers are located on the prolay control panel directly under the backward capstan drive motor. Access is provided with the main rear gate open.

To adjust the steady-state current through the prolay neutral coils, measure the voltage drop across the

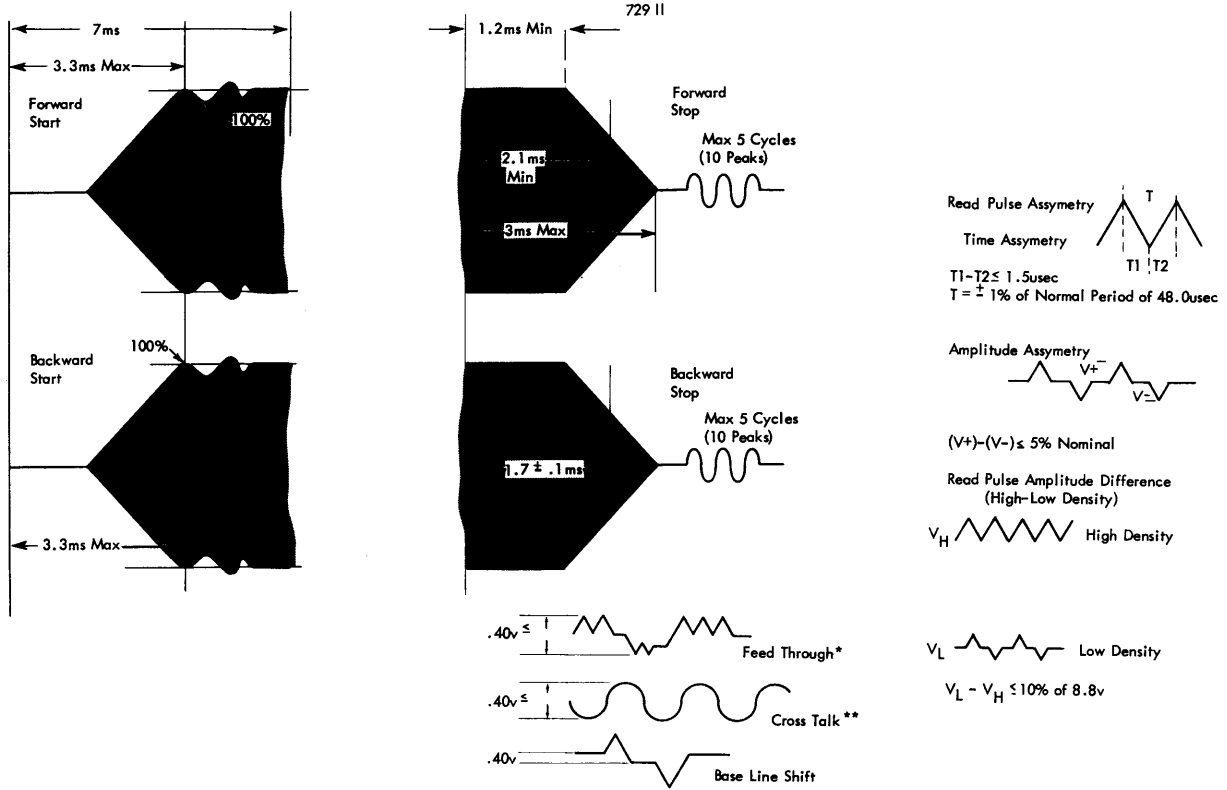

\*Feed Through - Signal picked up on the read head from write tracks while in write status

\*\*Cross Talk - Signal picked up from adjacent read tracks, in read status

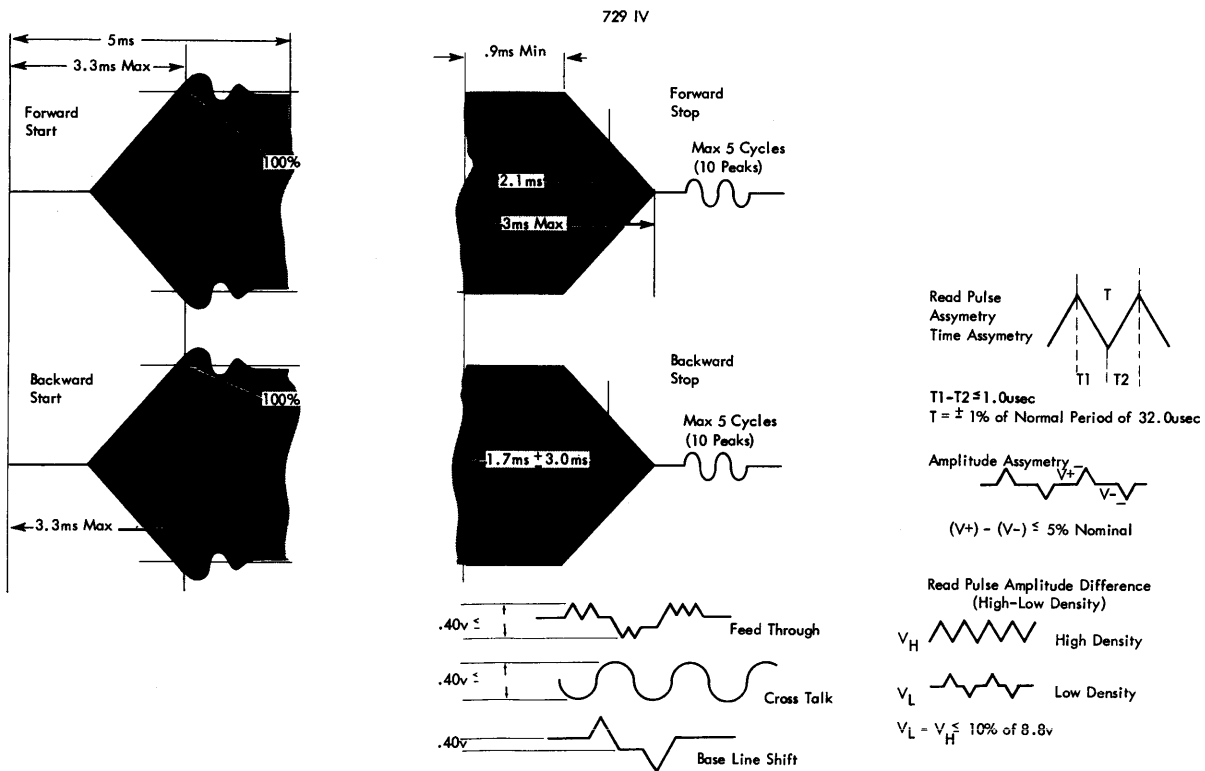

$\geq$  Greater than or equal to  
 $\leq$  Less than or equal to

Figure 41. 729 II and IV Start-Stop Timings

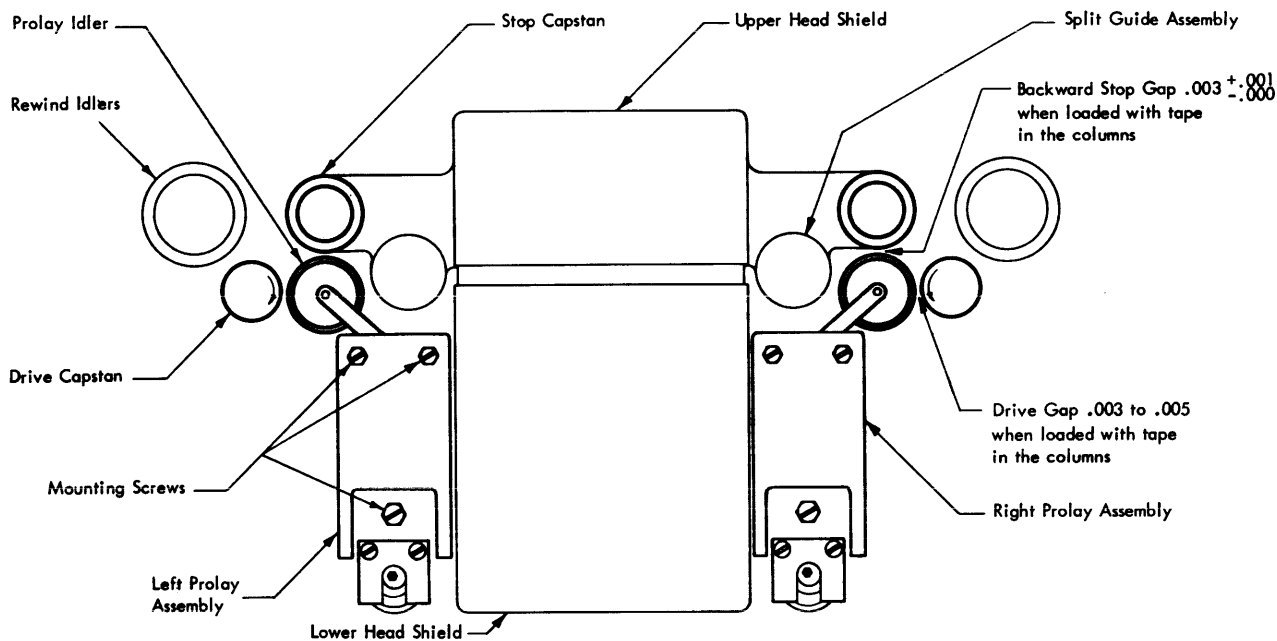

Figure 42. Prolay Drive and Stop Gap Adjustments

2-ohm, 25-watt parallel resistors on TB 11-6 and TB 11-7 and adjust the neutral potentiometers for a 3-volt indication (3 amperes).

2. Loosen the bottom mounting bolt.
3. Loosen the two top mounting bolts one-quarter turn to allow the prolay to pivot.
4. Initial adjustment of the drive and stop gaps should be: drive gap –  $0.005 \pm 0.001$  inch nominally; stop gap –  $0.004 \pm 0.001$  inch nominally. To accomplish this:
  - a. Open the door and manually pull out both capstans.
  - b. Set the front CE panel CO control switch to SUPPRESS CO.
  - c. Set the forward-backward switch to FORWARD. (This will place the tape unit in a backward stop status and allow adjustment of the left prolay drive and stop gaps – left prolay is in neutral status.)
  - d. Set the forward-backward switch to BACKWARD. (This will cause the right prolay to assume a neutral status and allow its drive and stop gap adjustments to be made.)

5. Check the forward start waveform, and attempt to adjust start timings to Figure 41. If glitching (breaking of the start waveform) of the envelope occurs, decrease the start gap until waveform is free of it. Glitch-

ing at about 2 ms from the rise of CO is caused by one of two conditions:

- a. Too large a drive gap on the driving prolay.
  - b. Too small a drive gap on the nondriving prolay (causes an overshoot through neutral, allowing the nylon idler to hit the drive capstan).
6. Repeat step 5 for backward start.
  7. Adjust the forward stop gap to obtain the timings shown in Figure 41. The 50% amplitude point of forward stop should not be less than 2.1 ms. Adjust the left stop capstan for the longest possible envelope without exceeding the noise burst specification (i.e., the left stop capstan must control stopping). The stop envelope must be at zero amplitude within 3.0 ms. If inter-record gap tests indicate short gaps, the forward full coast potentiometer may be used to fill in the forward stop envelope.
  8. Adjust the backward stop gap to obtain the timings shown in Figure 41. The backward stop capstan should be adjusted on-line to meet creep specification.
  9. Check that the minimum full coast times have been met.

The time required to pass a given character from the write head to the read head (about 0.3 inch) is:

729 II	4.0 ms
729 IV	2.7 ms



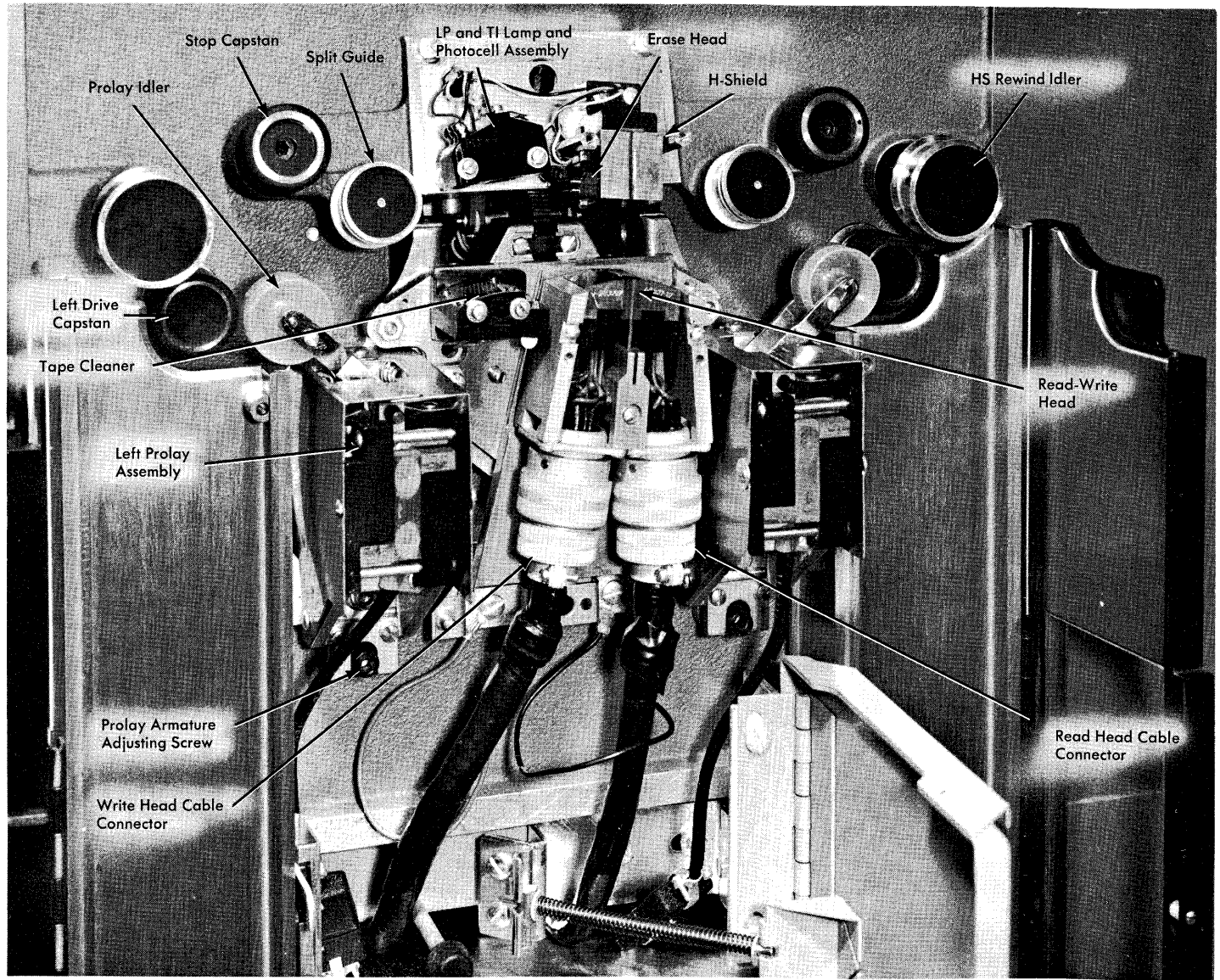
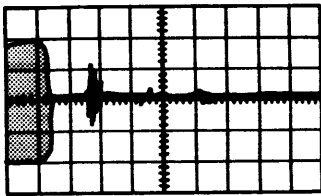
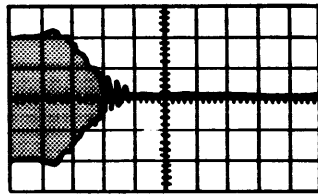

Figure 43. Read-Write Head and Transport Assembly



Sync: Fall of Go  
 Input: Read Bus  
 Defl: 5v/CM  
 Sweep: 1MSC/CM  
 Prolay Stop Gap Too Small.



Sync: Fall of Go  
 Input: Read Bus  
 Defl: 5v/CM  
 Sweep: 1MSC/CM  
 Prolay Stop Gap Too Large.

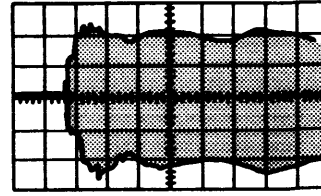

Sync: Rise of Go  
 Input: Read Bus  
 Defl: 5v/CM  
 Sweep: 1MSC/CM  
 Prolay Drive Gap Too Small.

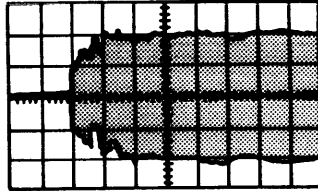

Sync: Rise of Go  
 Input: Read Bus  
 Defl: 5v/CM  
 Sweep: 1MSC/CM  
 Prolay Drive Gap Too Large.

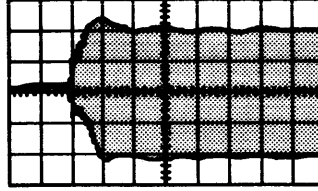

Sync: Rise of Go  
 Input: Read Bus  
 Defl: 5v/CM  
 Sweep: 1MSC/CM  
 Good Forward Start Envelope.

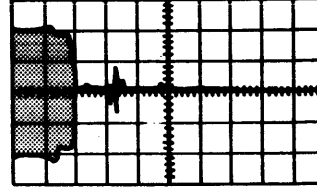

Sync: Fall of Go  
 Input: Read Bus  
 Defl: 5v/CM  
 Sweep: 1MSC/CM  
 Good Stop Envelope.

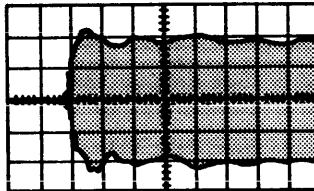

Sync: Rise of Go  
 Input: Read Bus  
 Defl: 5v/CM  
 Sweep: 1MSC/CM  
 Good Backward Start Envelope.

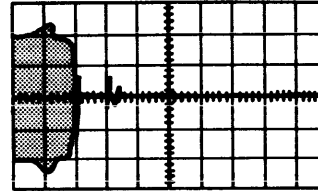

Sync: Fall of Go  
 Input: Read Bus  
 Defl: 5v/CM  
 Sweep: 1MSC/CM  
 Signal Decreases at 1.5MSC Full  
 Coast Set Correctly.

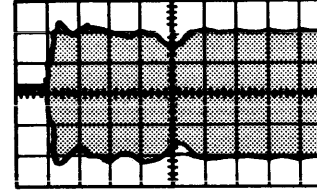

Sync: Rise of Go  
 Input: Read Bus  
 Defl: 5v/CM  
 Sweep: 2MSC/CM  
 Signal Loss 10MSC After Rise of Go.

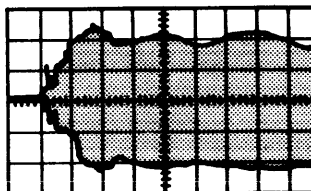

Sync: Rise of Go  
 Input: Read Bus  
 Defl: 5v/CM  
 Sweep: 1 MSC/CM  
 Forward Start Set to Compensate  
 for a Bound Prolay.

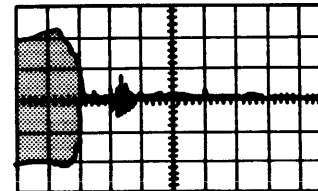

Sync: Fall of Go  
 Input: Read Bus  
 Defl: 5v/CM  
 Sweep: 1MSC/CM  
 Signal Up for 1.8MSC Full Coast  
 Too Long.

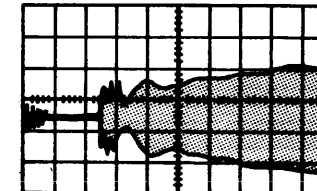

Sync: Rise of Go  
 Input: Read Bus  
 Defl: 2v/CM  
 Sweep: 1MSC/CM  
 Typical "Count Five"  
 Start Envelope.

Sync: Rise of Go  
 Input: Read Bus  
 Defl: 2v/CM  
 Sweep: 1MSC/CM  
 Typical "Glitching"  
 of Start Envelope.

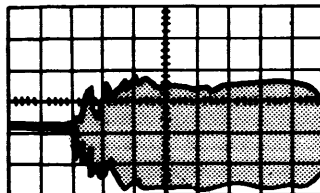

Typical arrowhead start envelope  
 caused by rough surface finish on  
 prolay pulley

Sync: Rise of Go  
 Input: Read Bus  
 Defl: 2 v/CM  
 Sweep: 1 MSC/CM

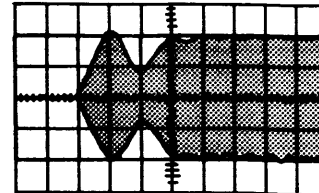

Figure 44. Waveforms

The control unit holds up GO, after WRITE CHECK CHARACTER (A in Figure 45) for the following:

729 II	3.0 ms
729 IV	2.0 ms

This delay requires that tape remain at full speed for at least 1.0 ms (729 II) or 0.7 ms (729 IV) after the fall of GO, to insure reading every written character (B in Figure 45). Adding a 0.2 ms safety factor, obtain minimum full speed coast times of 1.2 ms (729 II) and 0.9 ms (729 IV) by means of the coast potentiometer adjustment. Use no more full coast than absolutely necessary. The left potentiometer (viewed from behind) controls forward coast. Rotate both potentiometers clockwise to increase the amount of coast.

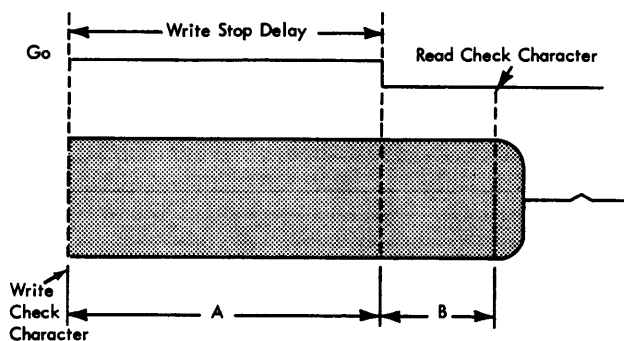

Figure 45. Stop Envelope

10. Check prolays for binds by making sure that the change in start time is equal to or less than 0.2 ms when varying go down time from 10 to 100 ms.

11. Check for a count five condition. This is a very slow acceleration after a 5 second or longer idle period, on prolays which may otherwise indicate a good start envelope on continuous start-stop. The initial 100 per cent amplitude must not be later than 3.3 ms. By adjusting the drive gap 0.001 inch either side of the nominal 0.005 inch setting, the fastest time at which 100 per cent amplitude level is reached can be obtained. This applies to both forward and backward start.

#### PROLAY ADJUSTMENT (ALTERNATIVE PROCEDURE)

The following is an alternative adjustment procedure which has been found to minimize glitching of the start-stop envelope.

1. Rotate the stop capstans to allow maximum stop gaps (dot on the face of the capstan is down).
2. Set wide drive gaps (about 0.010 inch) by eye.
3. Operate the CE panel to move tape forward in stop-start status. If the tape does not move, close the right prolay drive gap slightly until tape moves forward.

4. With tape moving forward, close the left drive gap to the point where glitching occurs. An audible click may be heard when the left prolay overshoots from stop through neutral and touches the left drive capstan. Open up the drive gap from this point. NOTE: Keep overshooting conditions to a minimum to prevent damage to the tape and /or nylon pulley.

5. Move tape backward in stop-start status. Close the right drive gap until the backward start envelope breaks up, again accompanied by an audible click. Open up the drive gap from this point. Ensure that drive gaps are opened up sufficiently to prevent glitching and still meet start-stop specifications.

6. Having adjusted the drive gaps until glitching has disappeared, vary the go down time through the lower ranges from 1.5 ms to 10 ms. In this critical low go down time range there will be a tendency for more overshoot. The drive gaps may have to be increased. NOTE: Worn pivots, usually at the main fork arm or the nylon pulley, may prevent the correcting of overshoot without the encountering of other problems, such as count five.

7. Adjust the stop capstans for 2.4 ms forward stop and 1.7 ms backward stop to the 50 per cent point. Recheck step 6.

8. The preceding technique usually produces a 0.004 to 0.005 inch drive gap. Check that drive or stop gaps are not less than 0.003 inch. Check that full amplitude start time is no later than 3.3 ms for all go down times. Check that the envelope is completely stabilized by 5.0 ms.

9. Final adjustment of stop capstans can be made on line, if necessary, to satisfy creep requirements.

NOTE: Inter-record gap diagnostics cannot be depended upon to indicate the previously described break-up or glitching caused by a prolay overshoot condition. For this reason it is not a good practice to make prolay adjustments (as opposed to stop capstan adjustments) without using a scope.

#### REMOVAL OF ARM ASSEMBLY

To remove an arm assembly from a prolay (Figure 46) when the prolay is mounted on a tape unit:

1. Make sure that the head assembly is up and all power is removed from the machine. (This prevents magnetic attraction of the armature to the pole pieces.)
2. Remove the head assembly lower covers.
3. Remove the front cover of the prolay so that the main pivot shaft is exposed.
4. Loosen the setscrew holding the main pivot shaft.
5. Withdraw the main pivot shaft by gripping the protruding knurled portion.
6. Withdraw the fork arm and armature assembly. Whenever an arm assembly is removed for lubrication

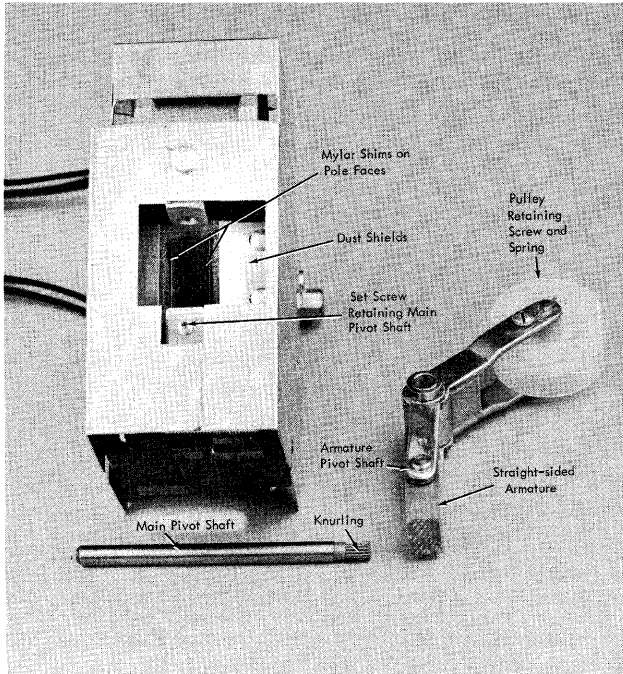

Figure 46. Removable Arm Prolay

or inspection, the top of the armature should be marked for reference. To make certain that the armature is properly oriented when reinstalling the arm assembly, the reference mark must remain on top. In some cases, turning the armature 180° (reversing it on its shaft) will significantly alter prolay operating characteristics. This reversal could cause a count five condition.

**CAUTION**

When removing, and particularly when replacing, fork arm assemblies, take extreme care not to damage the Mylar shims on the pole faces. Some pole face assemblies may be fitted with Mylar shims that have the cut-out portion (used with the earlier type "humped" armature). In these cases, be sure that the armature does not damage this cut-out portion. Turned, warped, or distorted shims will cause prolay malfunctions.

**REPLACEMENT OF ARM ASSEMBLY**

Replacement of the removable fork arm is the reverse of the removal procedure, but make certain of the following points:

1. Armature bevels line up with neutral pole pieces (upper right and lower left). See Figure 47.
2. Retaining wire screw for armature is toward the rear.

3. Retaining wire screw for nylon pulley is toward the front.
4. No binds in armature and fork arm.
5. No burns (armature and nylon pulley).

**REMOVAL OF COMPLETE PROLAY ASSEMBLY**

1. Drop power on tape unit.
2. Remove lower head decorative cover.
3. Disconnect two Jones plugs (stop-go and neutral).
4. Loosen hex-head adjusting screws at bottom of prolay.
5. Remove prolay front cover.
6. Using standard cover T wrench, remove three mounting bolts.
7. Remove prolay.

**DISASSEMBLY OF COMPLETE ASSEMBLY**

Binding prolays can cause erratic tape motion that is very difficult to diagnose and isolate. This condition is seldom perceptible by feel without disassembling the prolay. Binds can cause split characters, record length checks, missing records, skew, or unreadable records.

The binding may occur at either the forked arm pivot or the armature pivot. The erratic tape motion may also be aggravated by the full coast potentiometer or the positioning of the prolay or the stop capstan.

Replace prolay arm assemblies and readjust prolays every 4 to 6 weeks, or when inter-record gap tests indicate a significant change from previous readings, or when low gap lengths are outside specifications.

To disassemble the prolay:

1. Remove front and side shields.
2. Loosen two screws on neutral pole piece clamps.
3. Remove clamp and neutral coils.
4. Remove five screws holding GO and STOP magnets.
5. Remove fork arm pivot pin.
6. Remove magnets and arm assembly.
7. Remove armature pin.

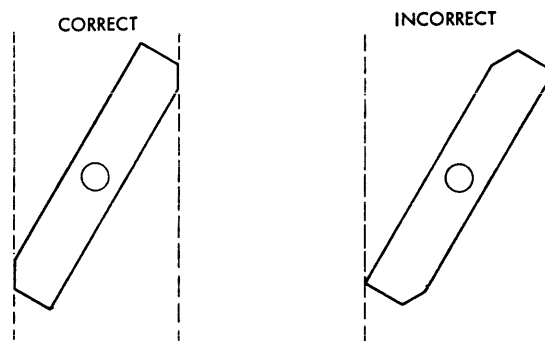

Figure 47. Prolay Armature, Reassembly

#### REASSEMBLY OF COMPLETE ASSEMBLY

Reassembly procedures are the reverse of disassembly except:

1. The assembled prolay should have 0.001 inch to 0.003 inch nylon idler end play.
2. All pivots must be free from binds.
3. Be sure that the laminated bar connecting the neutral pole pieces is replaced with the rivets facing outward, so that the flux will flow through the laminations and not across them.
4. Make certain that the two beveled corners of the armature go to the neutral pole piece. See Figure 47.
5. Make sure that residuals are clean and free from oil; residuals must not be torn or loose and must lie flat across the pole pieces.
6. Be sure that star-shape Mylar shields are not binding.
7. Make certain the two felt dust guards are not interfering with the arm travel.
8. Be sure that the covers are not binding on the arm.
9. Check that the 0.005 inch shim is in the proper place: lower right corner for right prolay; upper left corner for left prolay. To change a prolay from one side to the other, rotate the magnet assembly 180° and reposition the dust wicks.
10. Be sure that the armature clip retaining screw is to the rear of the prolay.
11. Position the cable clamp so that it does not touch the magnet bar.
12. Clean facings on the prolays and machine.

#### REPLACEMENT OF COMPLETE ASSEMBLY

Replace the prolay assembly on the tape unit as follows:

1. When installing prolay, turn stop capstan to low dwell.
2. Mount prolay with pivot pin in pivot bushing.
3. Insert three mounting bolts, after checking that the prolay is seated against the mounting surfaces.
4. Connect the Jones plugs. Check that the left prolay neutral plug and cable are routed to the left of the access door stop. This will avoid interference with the spring rod when the door is closed.

#### Short Inter-Record Gaps at Low GO Down Times

All prolays now in use contain 0.003 inch shims at each side of the main casting, making a total shimming of 0.006 inch. See Figure 40.

Shimming the prolay has essentially increased the force available to penetrate the drive capstan. This higher force overcomes count five tendencies.

Using shimmed prolays, short inter-record gaps become more prominent at the critical low go down

times, between 2.0 ms and 3.0 ms. At these low go down times the right prolay is signaled to go, just as it is reaching maximum acceleration away from the drive capstan, as a result of the previous stop signal about 2.5 ms earlier. This condition is aggravated on a shimmed prolay, because the nylon pulley is "thrown" away from the drive capstan by means of its previous deeper penetration into the capstan rubber surface.

Inter-record gap tests will show that machines with shimmed prolays produce shorter gaps in the low go down time range. On the 729 iv, the inter-record gap is likely to fall below the 6.1 ms specification. If this occurs, reducing the neutral current to 2.5 amp or 2 amp may help when the gaps remain consistently short. The neutral pole crossover bar may be rotated 90° to help eliminate this problem.

#### Stop Capstans

##### VISUAL INSPECTION AND OPERATIONAL CHECK

Check stopping area for cracks in rubber or worn flat surfaces. Imperfect surfaces cause irregularities in start and stop times and may cause skew problems.

##### CLEANING

Clean the stop capstan where the nylon pulley contacts it. Use the cleaning applicator moistened with IBM Tape Developer and Tape Transport Cleaner, P/N 517960.

##### CAUTION

Do not allow the tape transport cleaner to come in contact with the magnetic tape.

#### Drive Capstans and Motors

Each drive capstan is mounted on the shaft of a reluctance synchronous motor (1/20-HP, 60-cycle, 3-phase, 208-volt). See Figure 48. Each motor has a retract-

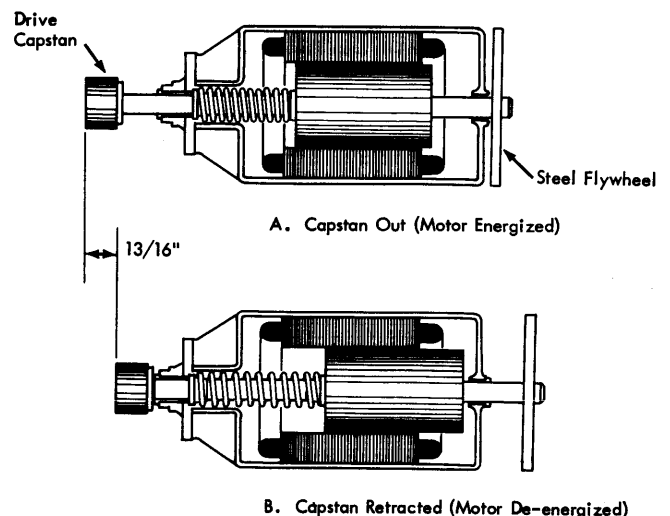

Figure 48. Capstan Drive Motor

able rotor that provides a type of solenoid action to extend the capstan when the field is energized. When the field is de-energized, the capstan is retracted by a light spring (on the shaft) that exerts pressure on the turning rotor. This spring does not overcome the friction of the shaft when the capstan is not turning.

Position of the capstan is determined by two microswitches located on the rear of the capstan motor. Attached to the operating arm of each microswitch is a magnet that is attracted to a steel disk mounted on the rotor shaft as shown in Figure 49. This disk operates the sensing switches and acts as a flywheel for smooth operation.

When the capstan is extended, the steel disk is in the position shown by the solid lines in Figure 49. The capstan-out switch arm is attracted toward the disk and the switch is operated. When the capstan is retracted, the disk is in the position shown by the dashed lines and the capstan-in switch is operated. The switch operating arms are adjusted so that the magnets are about 0.010 inch from the disk in attracted position.

#### VISUAL INSPECTION AND OPERATIONAL CHECK

Inspect the drive shaft for dirt, chips, ridges, and binds. Sloppy bearings can usually be detected by feeling the

capstans for vibration. Worn bearings will cause poor start-stop, break-up in start envelope, and variation or modulation of read signal.

All motors turn in the same direction when input power is phased 1, 2, 3. Phasing is reversed for one motor in the AC raceway. The arrow showing rotation is for factory inspection only. When in the machine, one motor will turn in a direction opposite to the arrow.

#### CLEANING

Clean the drive capstan surface and surrounding area with a cleaning applicator moistened with IBM Tape Developer and Transport Cleaner P/N 517960. In extreme cases the oxide build-up cannot be removed by tape transport cleaner. In these cases, the drive capstan can be cleaned by the judicious use of IBM cleaner, P/N 450608. Make certain to keep this cleaner away from the tape.

Do not clean the drive capstan while it is rotating under power. The capstan must be rotated manually while cleaning.

#### LUBRICATION

Lubricate the capstan motors with IBM 6 oil. Never allow oil to come in contact with the rubber capstan

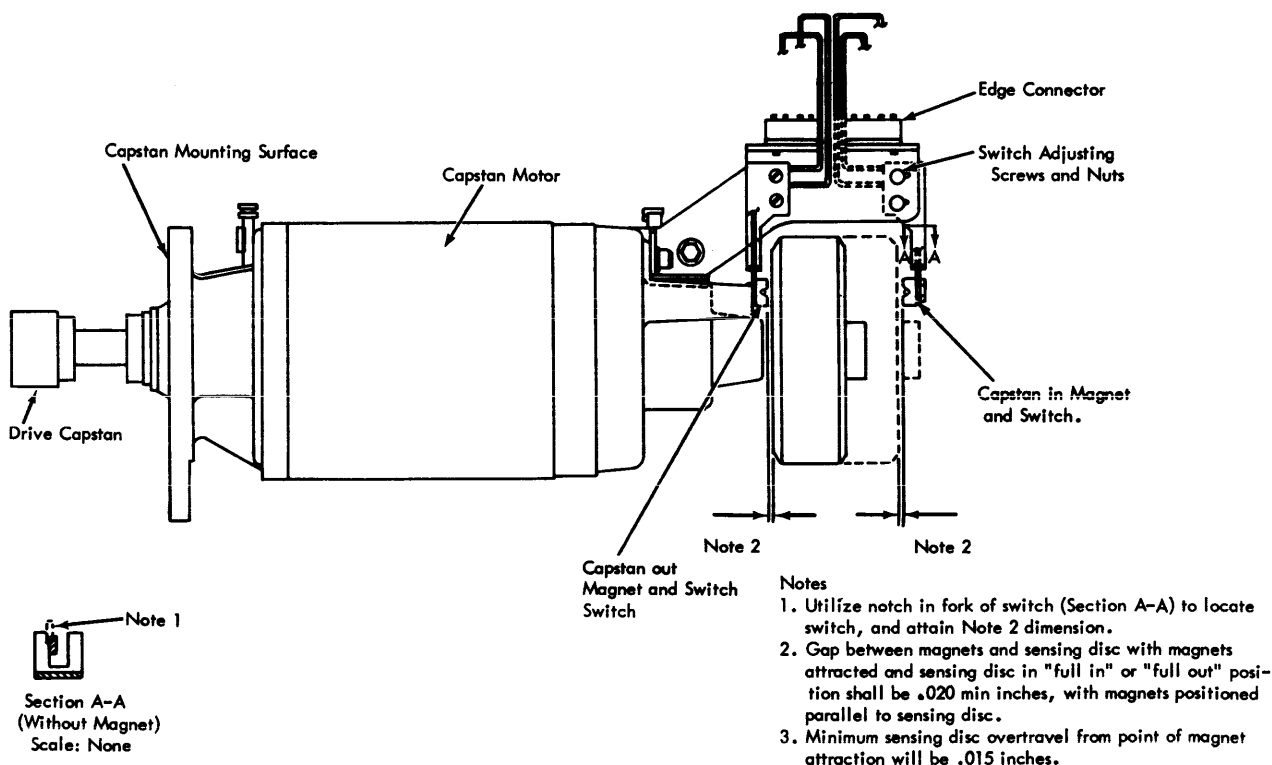

Figure 49. Drive Capstan Assembly

drive surface. For the front bearing (capstan end) proceed as follows:

1. Lubricate the shaft directly with one or two drops of oil on the end of a finger. Do not over-oil.
2. Move the shaft back and forth to move it into bearings. Make sure the shaft is clean and not over-lubricated. This procedure will permit a lubrication frequency of two to three months.

For the rear bearing, use two to three drops in the oil tube every three months.

#### REMOVAL

Drive capstan motors are mounted on the reverse side of the main casting and access is provided through the rear main panel gate. To remove the motor:

1. Turn power off.
2. Disconnect the motor cables and limit switch wires.
3. Remove three  $\frac{3}{16}$ -inch hex head mounting screws.
4. Twist motor slightly and pull it out.

#### REPLACEMENT

Replacement procedures are the reverse of removal procedures. Note, however, that drive capstans are individually fitted to the capstan drive motor shaft at the factory, and, therefore, a worn or defective drive capstan must be replaced by installing a complete capstan motor assembly.

#### CAUTION

When replacing capstan drive motors, use care to seat the motor properly against the base casting. Facing the rear of the tape unit, rotate the left motor clockwise to lock and the right motor counterclockwise to lock. Misalignment can result if the motor is turned in the wrong direction.

#### ADJUSTMENT, DRIVE CAPSTAN LIMIT SWITCHES

Remove all power from the tape unit and push the capstan motor shaft to both the in and out extreme positions. An audible sound can be heard when these switches operate. If either or both switches do not operate, loosen the appropriate switch, move tug screws, and alter their physical position as required. See Figure 49.

## **Vacuum System**

### **Vacuum Columns (Figure 17)**

The vacuum columns act as a storage area for the tape, allowing the tape to be moved across the head, at random, without having to turn the reels simultaneously. They also exert tension on the tape, preventing tape buckle at the head during starting and stopping.

The columns are rectangular with inside dimensions of 2.5 inches  $\times$  0.510 (+0.002, -0.000) inch. The transparent front of the column is hinged so it can be opened to permit easy cleaning. The top of the column is open; the lower end is connected to a manifold leading to a vacuum system that maintains a vacuum with tape in the column. Tape hangs in the column so only the sides of the semi-circular loop touch the sides of the column. Vacuum is maintained below the tape loop in the column, while atmospheric pressure exists above the loop.

#### VISUAL INSPECTION AND OPERATIONAL CHECK

Check the manifold mounting screws for tightness. Loose manifolds cause vacuum leaks. Check, for cracks or looseness, the plastic tubes connecting the vacuum switches to the vacuum column take-off ports.

#### CLEANING

Clean inside surfaces with a cleaning applicator and approved cleaning fluid. Remove all bits of tape and other dirt from the screen at the bottom of the columns.

#### LUBRICATION

Apply IBM 17 lubricant to the vacuum column door latches.

#### CAUTION

Do not lubricate any other part of the vacuum columns except the door latches. Lubricant in any other area will contaminate the tape.

### **Vacuum Column Switches (Diaphragm Switches)**

Each column contains two holes: one about one-third of the column length from the top; the other about one-third of the column length from the bottom. A vacuum-operated switch is attached, by a short tube, to each hole. As the tape loop is moved past the holes, the change in air pressure is sensed by the switch. The vacuum column switch is shown in Figure 50. The presence of a vacuum causes the diaphragm to move in a direction to transfer the contacts of the switch. For greater reliability, two sets of contacts are used in parallel.

#### VISUAL INSPECTION AND OPERATIONAL CHECK

Visually inspect the vacuum column switches for dirty, pitted or misaligned contacts, and loose diaphragm nuts and mounting screws. Also inspect for cracked or damaged diaphragms and dirt or foreign particles.

Check the tape unit for load, unload, and rewind operations. Excessive tape breakage during these operations may be due to defective or maladjusted vacuum column switches.

To check the switch operation, simulate tape loading without tape to bring up the vacuum. Connect a short

piece of tape (15 inches) to the outside of the column and alternately lower and raise this tape into the column. Observe the action of each vacuum column switch.

**ADJUSTMENT, VACUUM SWITCH**

*Push Rod:* The vacuum switch push rod should have 1/4-inch clearance between the adjusting nuts and the switch transferring contact strap. Position the adjusting nuts as required to attain this condition. See Figure 50.

**Tape-in-Column Switches**

A number of logic functions of the tape unit require that the presence of tape in the columns be sensed. This is accomplished by pressure sensitive switches called tape-in-column switches. One switch is mounted at the bottom rear of each vacuum column and is connected to the vacuum column by plastic tubing.

The tape-in-column switches are constructed like the vacuum column switches and operate as follows: When tape is out of the columns, the normally closed switch contacts are closed. When tape enters the columns, the flow of air in the columns is restricted and a partial vacuum is created, causing the tape-in-column switches to operate.

**Vacuum-Off Bellows Switch**

A bellows-type vacuum switch allows machine operation only if vacuum is maintained above a certain level. Lack of safe operating vacuum removes power from the tape unit run relays (R1 and R2). This bellows switch (vacuum safety switch) is mounted on the manifold between the vacuum columns (Figure 51).

When vacuum builds up within the manifold, atmospheric pressure closes the two flapper valves and causes the bellows portion of the switch to contract; the switch transfers, indicating that vacuum has reached the required level.

**CLEANING**

Remove dirt, dust, and foreign particles from the general area with a vacuum cleaner and a dry, lint-free cloth as required.

**ADJUSTMENT**

To check the vacuum safety switch adjustment, unload the tape unit and hold one of the two flapper valves open. Press the load-rewind key; the tape unit should not load until the flapper valve is released.

Remove both tape reels and turn on the door interlock cheater switch. Open the preamplifier access door,

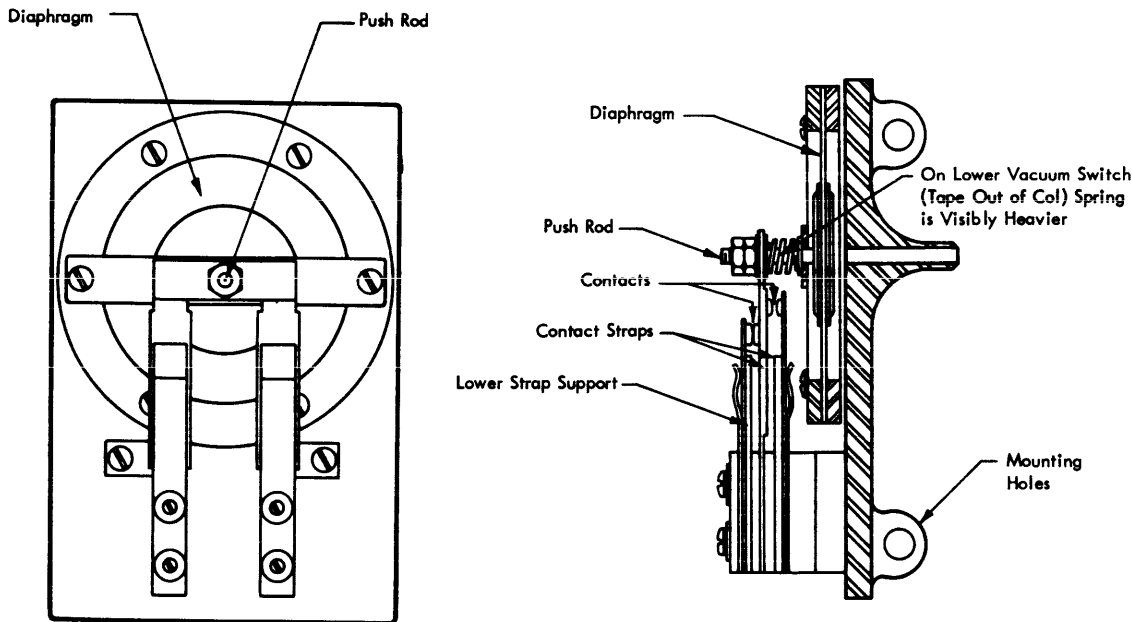

Figure 50. Vacuum Column Switch



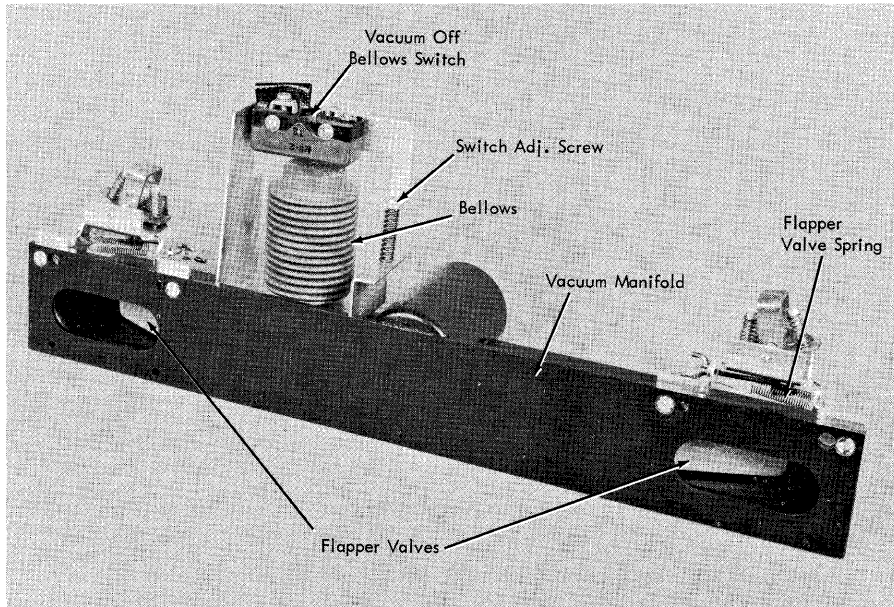

Figure 51. Vacuum Manifold Assembly

place the tape unit in the power-on status, and press the load-rewind key. Because there is no tape in the columns, the loading operation will continue indefinitely. Turn the bellows spring loaded adjusting screw clockwise until the loading operation stops. Rotate the adjusting screw counterclockwise until the loading operation starts, plus an additional one-fourth turn. See Figure 51.

### Flapper Valves

At the bottom of each vacuum column, separating the column from the manifold, is a flapper valve. This valve is similar to a door held open under spring tension. A rush of air down the column strikes the flapper valve and closes it. When tape is in the column, very little air passes down the column, and spring tension pulls the flapper valve open. With tape out of the columns, the flapper valves close and help maintain enough vacuum in the manifold to keep the bellows switch closed.

### ADJUSTMENTS

These flapper valves are assembled at the factory and should not require any further adjustment in the field.

If an installation is experiencing trouble with tape spilling from the right column during a loading operation, however, it is suggested that the following adjustments be made. The object is to cause tape to load into the right column first. This is accomplished by not letting the right flapper valve close as tightly as normal, thus producing more air flow in the right column. By doing this, tape is correctly positioned in the transport area when the head assembly is lowered.

Remove the right machine cover. Also remove the mounting screws for the right tape-in-column vacuum switch and place the switch down on the base of the machine. The adjusting screw can now be reached by inserting a long, round shank screwdriver into the vacuum channel from the right side of the machine.

Turn the right (outboard) flapper valve adjusting screw five turns clockwise. This will prevent the flapper valve from fully closing.

Depress the load-rewind key. If the bellows switch is still able to transfer as vacuum builds up in the manifold, no additional adjustment is necessary. If the switch does not transfer, slowly turn the adjusting screw counterclockwise until it just does. Now turn the adjusting screw an additional half turn.

Tape should now load into the right column first.

## Reel Drive Assemblies

### Forward and Reverse Drive Motors

The reel drive clutches are pulley driven by two  $\frac{1}{4}$ -HP, 3-phase, 208-volt, AC motors (1140 RPM). One motor provides forward motion; the other, reverse motion.

The forward drive motor is in the lower right corner and is connected to the two center clutches by two V-belts adjacent to each other. The reverse drive motor is in the lower left corner and is connected to the two rear clutches by two V-belts (Figure 52).

#### CAUTION

Use extreme care when working inside the tape unit to avoid injury from the reel drive motors and belts. Whenever possible, the motors should be unplugged as a safety precaution.

### Reel Drive Clutches

Each tape reel mounts on a hub protruding from the upper front of the tape unit. This hub contains a rubber rim that grips the reel tightly when the knob in the center of the hub is tightened.

The hub is on a shaft controlled by three magnetic powder clutches: one for forward motion, one for re-

verse motion, and one for a brake. The innermost part of the magnetic clutch (Figure 53) is a rotor keyed to the reel shaft. Surrounding the rotor is the clutch housing, which is mounted on sealed bearings and is free to turn on the shaft. Each clutch housing (a three-groove pulley) is driven by a continuously running three-phase motor. Embedded in the clutch housing is a coil, with connections brought out to slip rings on one end of the housing.

Between the rotor and the housing is a mixture of iron powder and graphite. When current flows through the coil, flux is produced. The flux solidifies the iron and graphite mixture and causes the rotor and housing to be essentially locked together. Although the housing turns continuously through pulley action, the rotor does not move with it unless current is flowing through the coil. As current flows through the coil, the rotor begins to move with the housing, turning the hub and reel at the front of the machine.

Because of the gradual build-up of current in the coil (due to inductance), the torque transmitted is proportional to the current, producing a smooth acceleration. This smooth acceleration prevents tape breakage by not shocking the tape into motion. The

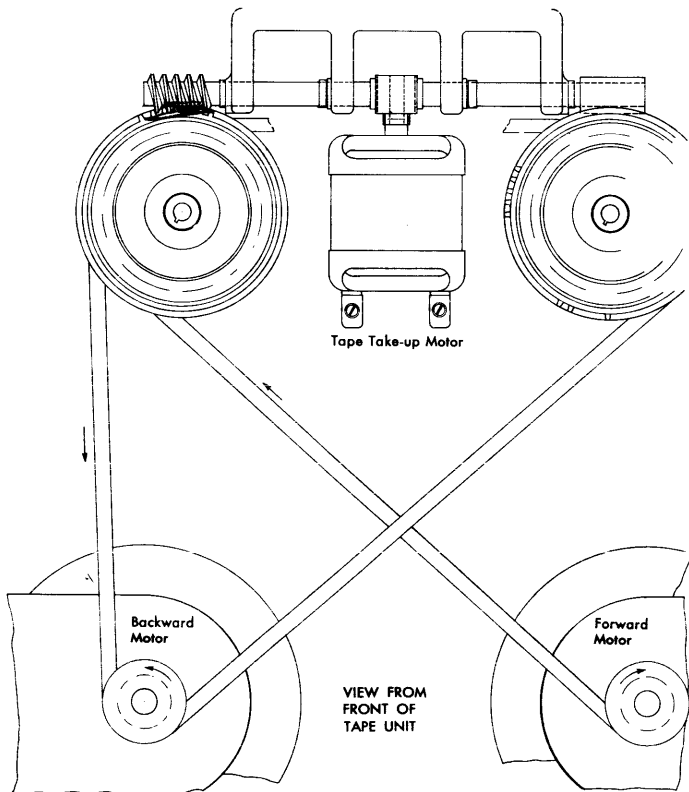

Figure 52. Drive Motors and Pulleys

magnetic powder clutch was selected for its ability to produce smooth acceleration and large torque with small control current. To hold the iron-graphite mixture in the flux gap, ridges are designed into the clutch parts. These ridges assist centrifugal force to keep the powder in the magnetic gap. The iron-graphite mixture polishes but does not wear clutch parts.

Three clutches are mounted on each shaft with all rotors keyed to the shaft. The front clutch has a stationary housing and is a brake. The middle clutch housing is driven clockwise and is the forward drive. The rear clutch housing is driven counterclockwise and is the reverse drive.

In the unload status, both brake clutches are energized and are controlled by a reel release switch located below and to the left of the file reel (Figure 17). When this switch is depressed, power is removed from both brake clutches to permit them to be turned manually.

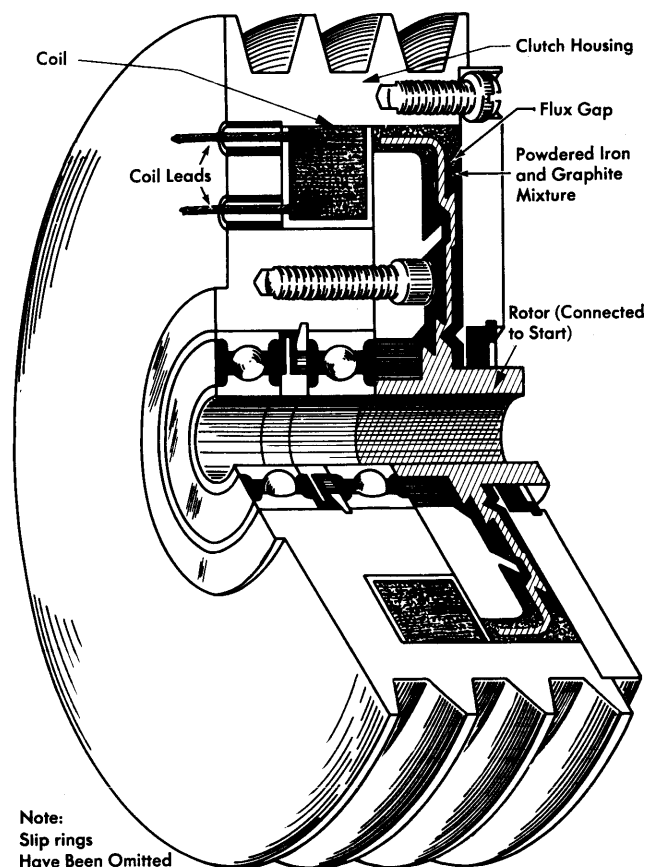

Figure 53. Magnetic Clutch

#### VISUAL INSPECTION AND OPERATIONAL CHECK

Check for worn or cracked brushes, loose Jones plugs, and frayed or broken wires. Check all clutches for powder leaks; powder leaks show up as a fine black powder on the covers and surrounding area. (Do not mistake black rubber deposits from drive belts as powder leaks.)

**Clutches:** Check that clearance between brush holder and slip ring is 0.040 to 0.068 inch.

**Reel Drive Hubs:** Inspect the rubber reel latch ring for uneven wear, breaks, cracks, dirt and elasticity.

**Reel Drive Shafts:** Check the reel drive shafts for lost motion due to loose or worn taper pins used to connect the reel drive hub to the reel drive shaft.

**Reel Drive and Brake Clutch Assemblies:** Check the reel drive clutch bearings for binding and excessive wear. Rotary motion should be smooth and free, with no lateral end play. Check the clutch commutator rings for carbon deposits and excessive pitting.

#### CLEANING

**Reel Drive Hubs:** Clean the rubber surface with a clean, lint-free cloth and approved cleaning fluid.

**Reel Drive and Brake Clutches:** Burnish the clutch commutator-rings with a fine crocus cloth, as required, to provide good electrical contact and to prevent arcing.

**Belts:** Belt tension should be ½-inch deflection with a ½-pound force applied in the center of the V-belt.

#### LUBRICATION

**Reel Drive Hubs:** If necessary, apply small amount of talcum powder on the rubber ring surface to prevent the tape reel from sticking.

**Reel Drive and Brake Clutch Assemblies:** Do not lubricate any portion of the clutch drive assembly; this may cause permanent damage to the clutches.

**Stop Clutch Worm Gear:** Apply IBM 20 grease as required.

Figure 54 shows the tape unit drive mechanisms.

#### MECHANICAL ADJUSTMENT

**Belt Alignment and Tensions:** Position the drive motors in their slotted holes for 0.5 inch belt deflection in the center. Deflection may be accurately checked by using a 0.5 inch spring scale.

**Clutch and Brake Shaft Assembly End Play:** End play on these shafts can be reduced by adjusting the nut on the involved end of the shaft.

#### CAUTION:

Do not make this adjustment too tight, as this will cause burned bearings and excessive drive motor load. If this adjustment does not eliminate shaft end play, replace the entire assembly.

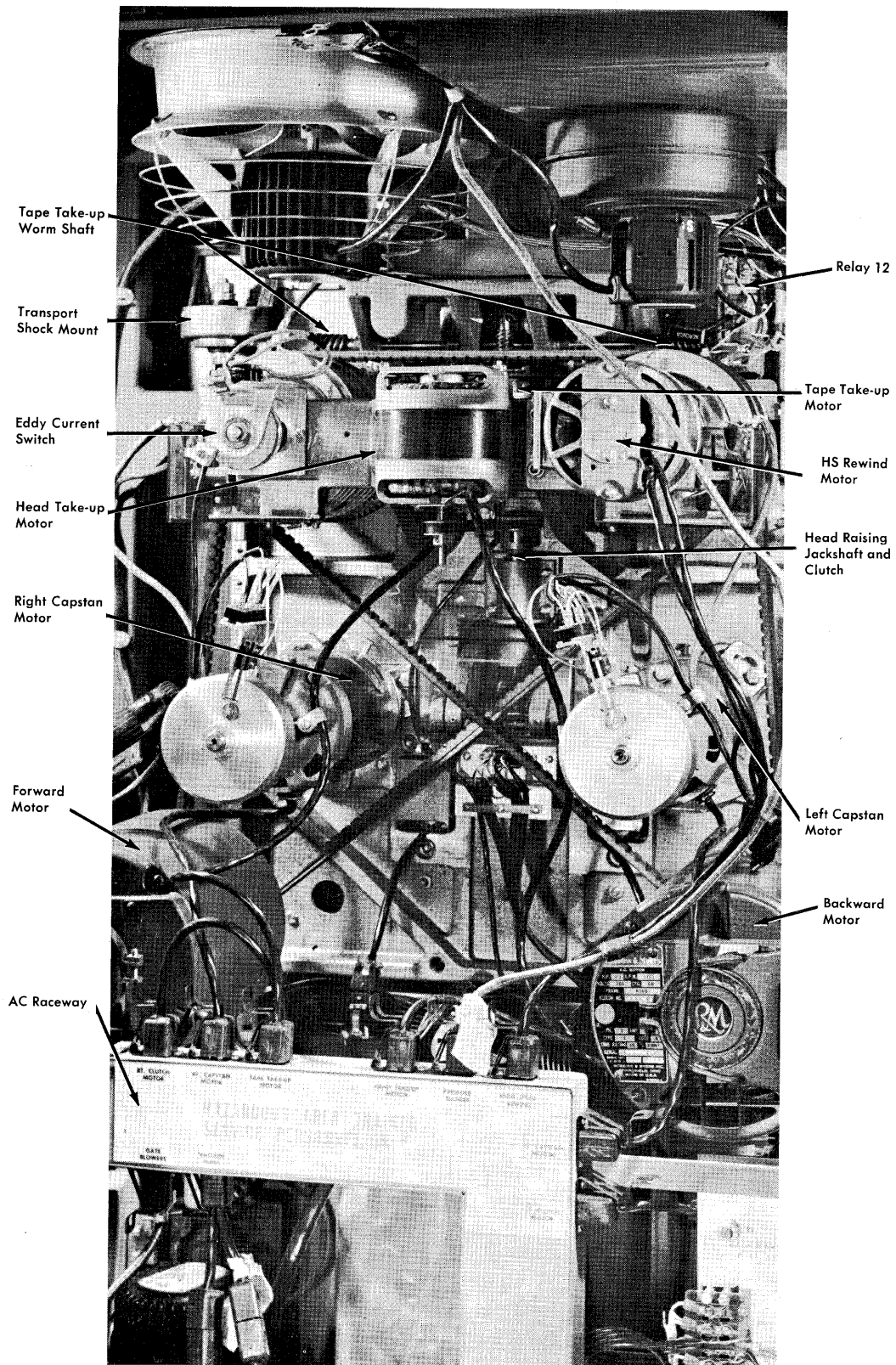

Figure 54. Drive Mechanisms

ELECTRICAL ADJUSTMENT

**Brush-to-Clutch Commutator Ring Contact Resistance:** With the tape unit power cut off, connect an ohmmeter to the brush and commutator ring of each clutch. This resistance should not exceed 25 ohms.

**Brush to Commutator Ring Adjustment:** To prevent arcing (which is a source of noise) make sure there is 0.040 to 0.068 inch clearance between the brush block and the commutator ring.

**Reel Drive Clutch Energizing Voltage:** A tachometer generator is needed to make the necessary magnetic clutch current adjustment. Figure 55 shows the tachometer assembly, which is the one used on IBM 720 and 1403 Printers.

Replace the reel knob with the tachometer assembly and connect it to an oscilloscope with a direct probe. Scope setting: 1 volt/cm and 50 ms/cm sweep. Trigger externally from the current jacks on the clutch adjustment panel (Figure 57). Adjust each clutch response with its respective potentiometer to obtain curves shown in Figure 56.

Use a full reel of tape when measuring and adjusting response. Loop a piece of magnetic tape into the columns, securing the end to the outside of the vacuum columns. Disconnect the capstan motors and load drive. The loop of tape is then physically positioned about the proper port to check response of full reel mounted on the hub.

If the clutch response cannot be brought to specifications with full adjustment of the potentiometer, check the current in the circuit. With the potentiometer in

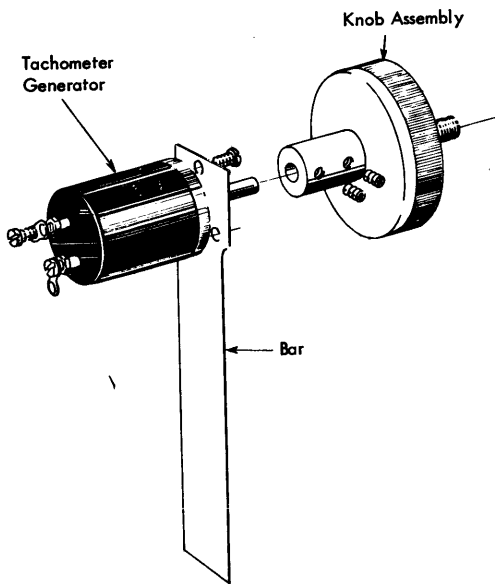

Figure 55. Tachometer Assembly

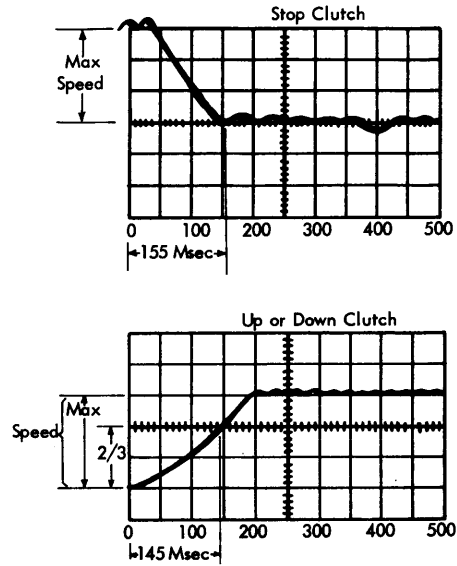

Figure 56. Typical Clutch Response Curves

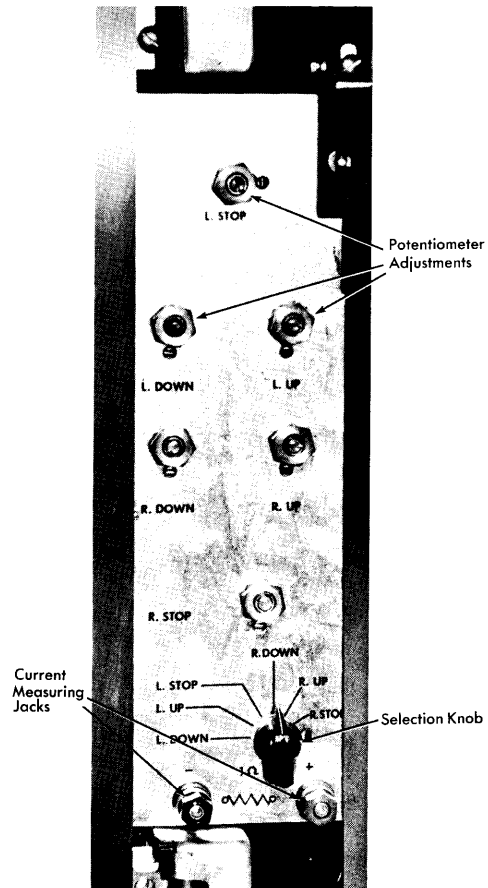

Figure 57. Clutch Adjustment Panel

the extreme clockwise position, the current should be 420-450 ma. If the current value is correct and the clutch is still out of specification, the clutch must be rebuilt.

Clutch response specifications (Figure 56):

1. Up and down clutch must obtain two-thirds of maximum speed in 0.135-0.150 seconds with a full reel of tape.

2. The stop clutch must stop a full reel of tape from full speed in 0.145-0.160 seconds.

When a new or rebuilt clutch is installed, clutch response should be rechecked and adjusted if necessary after one week of operation.

#### REMOVAL, UP AND DOWN CLUTCHES

Up and down clutches at rear of tape unit are best removed individually without removing the complete assembly.

1. Remove both side covers and top cover (four bolts, two on each side).

2. Support both left and right clutch assemblies with cord or wire suspended over the cross members supporting the air filter assembly. **NOTE:** Do not bend clutch shaft. Walk belts off sheaves on clutch.

3. Remove wires from brush assembly between stop and center clutch. It is not necessary to remove wires on rear clutch brush assembly.

4. Loosen setscrew in high-speed rewind motor coupling.

5. Remove two dowel pins from rear support casting.

6. Remove four Allen head bolts securing rear support casting to main clutch support.

7. Remove rear support casting, including high-speed rewind motor, and lay across AC raceway and drive motors.

8. Remove adjusting nut, retainer, and bearing from rear of shaft.

9. Remove rear clutch from the shaft. Shims may be fitted here.

10. If center clutch is to be reworked, remove Woodruff key for rear clutch.

11. Slide center clutch to the rear as much as possible by hand.

12. Remove two screws holding brush block support bracket. The top one is best removed with a long screwdriver from the top; this is the only reason for removing the top cover. After removing the bracket, slot the top hole so that future removals will require only that the top screw be loosened.

13. Remove the two halves of the split spacer between the middle clutch and stop clutch.

14. Slide the middle clutch to the front of the machine and remove its Woodruff key.

15. Slide middle clutch off the back of the shaft.

#### REMOVAL, STOP CLUTCH

1. Remove both side and top cover.

2. In most cases it is not necessary to remove the long vertical side covers to drive the pin from the hub housing. Adequate swing on the hammer can be obtained by driving the pin upward. If the pin is extremely tight, however, it may be necessary to remove these interior covers (either side of front door).

3. Support shaft with V-block and drive pin from clutch hub.

4. Do steps 2 through 7 and 12 in removal procedure for up and down clutches.

5. Remove clutch assembly from the rear of the machine.

6. To remove stop clutch from shaft, remove the two halves of the split spacer after separating the stop and center clutches as much as possible by hand.

7. Slide the stop clutch to the rear of the shaft and remove its Woodruff key.

8. Slide clutch off front of shaft.

Reassemble in reverse order. Be sure to replace all shims in their original locations. When replacing nut on back of shaft, adjust for 0.005 inch end play and lock with retainer.

#### CLUTCH BRUSH REPLACEMENT

1. Completely disassemble brush block assembly.

2. For block assemblies that do not have soldered pigtailed: Locate 0.250 inch from unbent end in center of strap. Punch and drill 0.052 inch hole (No. 55 drill). Countersink 82° × 0.093 inch diameter both sides (No. 42 drill). Hole should be centered over brush.

3. On block assemblies with soldered pigtailed, unsolder the pigtail, keeping the hole clear of solder.

4. Insert new brush into block so that it seats properly on its shoulder.

5. Insert new spring over pigtail and allow to sit on brush.

6. Locate brass strap in position, allowing the pigtail to extend up through the drilled hole. Do not tin more than ¼ inch of pigtail.

7. Solder pigtail to brass strap. File solder flush to within ½ inch.

#### CAUTION

Care should be used when soldering. Solder should completely fill the hole in the brass strap, but not be allowed to flow down the pigtail lead. Apply solder sparingly; soldering will stiffen the lead, and in some cases of continued flexing, the lead will break. The lead should have enough slack to allow twisting of the brush. If the lead is not slack, the twisting action will pull the brush away from the slip rings.

8. Check brush for free action and full return to normal position.

9. Check resistance from brush to strap for a good soldered joint.

10. Clean slip rings with fine crocus cloth or polishing stick, P/N 450503. *Do not use tape cleaning fluid or lubricants of any kind.*

#### CLUTCH RECHARGING

1. Remove four screws and cover plate.

2. Remove outer (white) felt washer and inner (black) felt washer and discard.

3. Check bearing (P/N 535626) for binds. Replace if necessary.

4. Install new inner felt washer, P/N 533208, and rotating disk.

5. Fill chamber with entire vial of powder, P/N 332770. The vial contains a premeasured amount (22 grams) of powder. Fill chamber from outer periphery, tapping and rotating the chamber and disk.

6. Thoroughly clean edge where cover sits on the clutch.

7. Install new outer felt washer, P/N 535627.

8. Replace cover and secure with four screws.

#### Tape Take-Up Mechanism

The tape take-up mechanism consists of a 3-phase motor mounted above and between the two reel clutch shafts (Figure 52) and is geared to each brake clutch housing so that when the left stop clutch housing is rotated counterclockwise by the motor, the right stop clutch housing rotates clockwise. With the brake clutches energized, the tape reels rotate so that tape is removed from the columns. When the tape take-up motor is reversed and the brake clutches are energized, the tape reels rotate so that tape is dropped into the vacuum columns. When the tape take-up motor is not operating, the brake clutch housings are held stationary by the worm drive mechanism.

#### High-Speed Rewind

To provide fast reel motion during high-speed rewind, an additional motor (1/12 HP, 3-phase, 208-volt, AC, 3450 RPM) is direct coupled to the file reel shaft. During normal tape motion, the rotor is turned with the file reel shaft. When the tape unit goes into a high-speed rewind operation, the magnetic clutches are de-energized and the high-speed rewind motor drives the file reel shaft. Tape is pulled directly from the machine reel. The location of the high-speed rewind motor is shown in Figure 54.

Mounted to the rear of the take-up reel shaft is an eddy current sensing device (Figure 59). Its purpose

is to sense when the reels have coasted to a stop so that tape can immediately begin loading into the columns.

#### DANGER

If the tape unit is placed in a high-speed rewind operation without a reel on the left side, the metal latch ring can fly off. When checking high-speed rewind circuitry, it is essential that a reel always be on the left side of the tape unit (with the hub tightened) whenever the tape unit is in high-speed rewind.

#### OPERATIONAL CHECK

Run the tape unit through the high-speed rewind cycle and compare the performance against the following requirements:

1. With just over  $\frac{1}{2}$  inch of tape on the machine reel, the tape unit should begin rewinding.

2. At the point with  $\frac{1}{2}$  inch of tape on the reel, the tape unit should kick out of high speed and begin applying brake to the machine reel.

3. When rewinding a full reel, the tape unit should brake smoothly to a stop, so that there is  $\frac{1}{8}$  inch of tape on the machine reel before loading tape.

4. The tape unit should take between 40 to 70 sec for rewinding a full reel. Approximately two-thirds of this time should be in high speed and one-third in low speed.

If the operation does not meet the requirements, adjust as necessary.

#### ADJUSTMENT

1. Check the voltage drop across the high-speed rewind photo lamp. The drop should be 4 (+1, -0.5) volt. If it is not, reset by adjusting the sliding tap on resistor 19 located in the motor control box (Figure 32).

2. Focus and position the high-speed rewind light (Figure 58) so that the vertical slot of light is centered on the photocell in the finger guard between the reels.

The light and focusing mechanism are located behind the operator's panel, on the right side. To adjust,

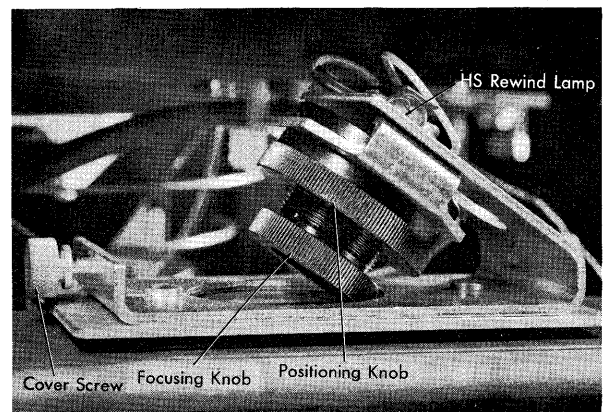

Figure 58. H-S Rewind Lamp Assembly

open the panel and remove the light cover. The large knurled ring is used for positioning and the small ring for focusing.

3. Run  $\frac{1}{2}$  inch of tape onto the machine reel, and place the tape unit into unload status.

4. Pull the finger guard cover forward and turn clockwise for unobstructed view of photocell hole.

5. Using the large positioning ring, move the light beam so that the shadow of tape on the machine reel just cuts across the top edge of the photocell hole.

6. Set the machine reel brake adjusting potentiometer at mid-position. This is resistor 10, mounted on the hinged cover of the motor control box.

7. Hand wind approximately 25 more turns of tape onto the machine reel.

8. Press the load rewind key.

If the adjustments to this point are correct, the unit should go into high-speed rewind. If it does, go on to the next step; if not, recheck the shadow on the photocell (steps 3, 4, and 5) and repeat steps 7 and 8.

9. Run a full reel of tape onto the machine reel.

10. Rewind the full reel and check the results against the requirements listed in "Operational Check." To meet these requirements, it is necessary to adjust the eddy current sensing device and brake potentiometer for  $\frac{1}{4}$  inch of tape before loading. Check by using a full reel of tape.

### Eddy Current Sensing Device (Figure 59)

This device is mounted on the rear portion of the machine take-up reel shaft and consists of two main sections.

A 2-inch circular plate (rotor) with eight permanent magnets secured to it is fastened to the reel shaft and free to rotate with it. A second plate (the stator) is mounted on a fixed bracket and free to turn within limits. This plate is placed close to and parallel with the eight magnets. On this second plate is a mercury switch and a counterbalance. (The switch is normally open.) During a high-speed rewind, the force of the magnets tends to overcome the counterweight, move the assembly clockwise (from the rear of the machine), and close the contacts. The switch will remain in this position until the reel coasts to a near stop; the counterbalance will then rotate the assembly counterclockwise again. This will open the switch and signal the circuitry that the high-speed rewind portion of the cycle has ended.

#### VISUAL INSPECTION AND OPERATIONAL CHECK

To check for the proper sequence of operation, the following procedure should be followed:

1. Place a full reel of tape on the right reel (machine reel).
2. Disconnect the tape take-up motor.
3. Depress the load-rewind switch.
4. After the tape drive has picked up speed in a high-speed rewind, depress the reset key.
5. Observe that when the eddy current switch transfers and picks relay 6, the reels have just come to a stop. It is not necessary to look at R-6; it will make an audible click. Increase the gap between the rotor and stator for less time delay and decrease the gap for more delay.

#### ADJUSTMENT

Adjust the gap between the rotor (the rotating member of the switch) and the stator (the member on which the mercury switch is mounted) for 0.015 to 0.020 inch. The use of three IBM cards is ideal for this adjustment.

The internal contact prongs of the mercury switch must be on a horizontal plane.

### Base

#### Front Door Assembly

The sliding glass spring drum assembly controls the sliding glass panel of the front door (Figure 60). A spring drum assembly is located on each side of the inside of the door, as shown in Figure 61.

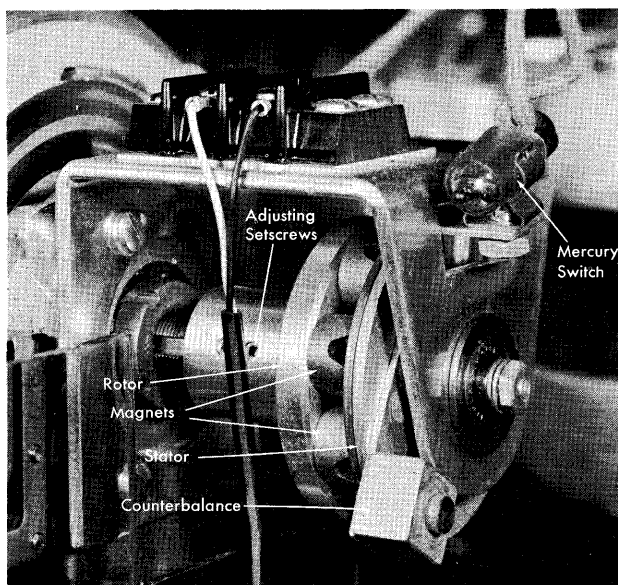

Figure 59. Eddy Current Sensing Device



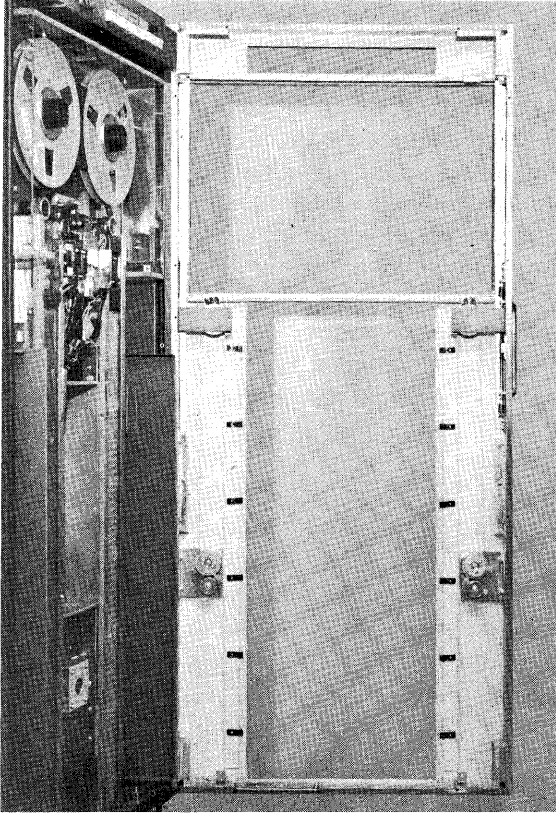

Figure 60. Sliding Glass Assembly

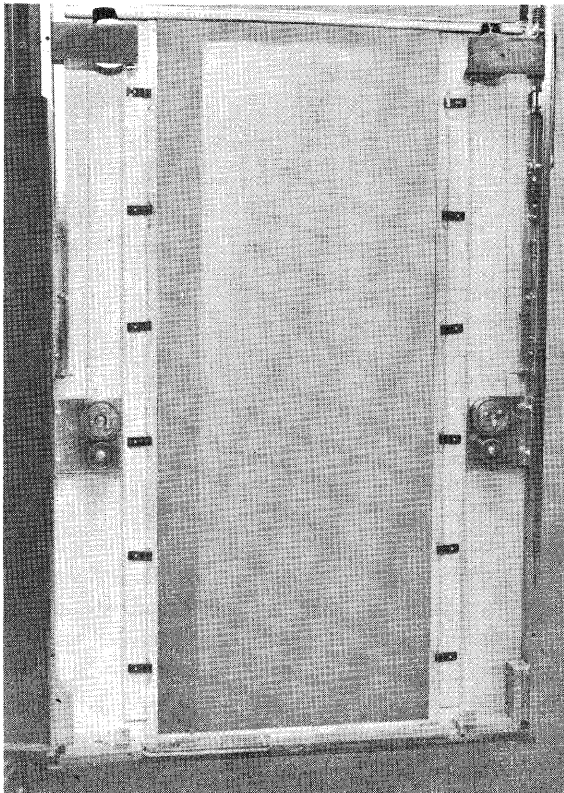

Figure 61. Sliding Drum Spring Drum Assembly

#### LUBRICATION

The following lubrication should be performed every 4 to 6 months, or more frequently depending on usage.

1. Lubricate pulley shafts, front sliding door pulley and front sliding door spring motor with IBM 6 lubricant.
2. Apply IBM 22 grease sparingly on door cables; this will reduce breakage.
3. Lightly oil all studs and negator spring with IBM 6.
4. Use a grease stick, P/N 461077, on the:
  - a. Door check latch cam face, which is at the lower right of the door to detent it while it is open.
  - b. The sliding glass nylon tube seal surfaces that guide the sliding glass.
5. Apply IBM 17 grease sparingly to the door latch.

#### GUIDE ADJUSTMENT

The front door sliding glass is tapered so that it is narrower at the top than at the bottom. With the window closed, there normally is a minimum of play sideways (about  $\frac{1}{16}$  inch maximum). With the window open there will be a maximum of  $\frac{3}{16}$  inch. Because of this, any adjustment to the glass should be done with the window closed.

In and out movement is to be held to a maximum of  $\frac{1}{2}$  inch.

#### REMOVAL, INNER OR OUTER CABLE

1. Remove the lower outside mounting panel cover by removing the four mounting screws.
2. Remove the mounting bracket from the upper pulleys by removing the two holding screws.
3. Remove the cable by loosening the three screws on the upper pulley and untying the knot.
4. Loosen the three screws on the lower drum assembly (Figure 62).

#### REPLACEMENT, GLASS PULLEY (INNER) CABLE

After removing old cable from the negator drum (taking care not to damage spring), mount new sliding glass cable as follows:

1. Bring sliding glass down to the stops.
2. Thread hooked end of cable through small hole in sliding glass mounting bracket.
3. Insert hooked end of cable through eyelet in pulley disk.
4. With sliding glass down to the stops, and the pulley held at 3 or 9 o'clock, the cable must be taut. (Right and left glass pulleys are mirror images.) If there is slack in the cable or if the glass moves up from the rubber stops, adjust the stop assembly by moving stop screws up or down as required.
5. Move glass to closed position, keeping assembled cable taut on glass pulley.

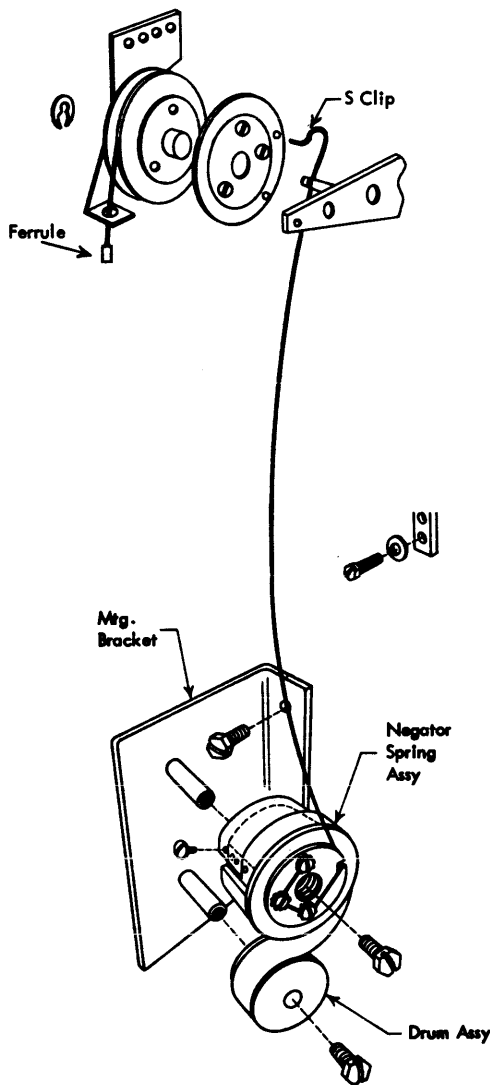

Figure 62. Sliding Drum Spring Drum Pulley Assembly

#### REPLACEMENT, DRUM PULLEY (OUTER) CABLE (FIGURE 61)

1. With the sliding glass closed, the eyelet on drum pulley side is automatically positioned on the horizontal axis of the pulley. The cable hook is inserted into this eyelet.
2. Turn spring drum assembly one turn.
3. Holding spring tight, wind cable six times around drum.
4. Bring cable out through slot on drum. Tie cable down under three lock washers.
5. Run the sliding glass up and down a few times, making sure that the cable does not bind on the drum.

#### Reel Door Interlock

An interlock switch in the upper left corner of the tape unit is closed when the tape unit door and its sliding plastic panel are closed. When the door interlock switch contacts are open, all operations are prevented except unload. The interlock switch may be disabled for service and test purposes by a sliding plunger in the switch assembly.

#### ADJUSTMENT

The switch should transfer when the sliding glass is  $\frac{1}{8}$  to  $\frac{1}{2}$  inch short of seating in its closed position.

#### File Protection

To protect master files, a groove is molded in the rear side of each tape reel to prevent accidental writing on a reel of tape. A plastic ring may be placed in this groove. If the ring is not in the groove of the file reel, writing is suppressed but reading is allowed. If the ring is in the groove of the file reel, both reading and writing may occur.

To sense the presence of the ring, a pin protrudes from the front of the tape unit above the file reel hub (Figure 17). The pin is connected to the armature of a duo relay armature mounted behind the panel. If a ring is in the groove of the file reel, the pin is pushed to the rear, moving the relay armature. This action closes the relay contacts, energizing the relay to permit writing. When the relay is energized, the sensing pin is pulled clear of the plastic ring so that it does not drag as the reel turns. If the groove in the reel is empty, the pin is not actuated, the relay is not energized, and writing is prevented.

#### VISUAL INSPECTION AND OPERATIONAL CHECK

The file-protect circuitry is controlled by a relay plunger mounted above and behind the file reel and extending through the main casting. When the plunger is depressed, either manually or by a plastic ring on the tape reel, the tape is not file protected, and information can be rewritten on it. The file-protect relay is energized through its own contacts and can be disengaged by pressing the unload key or by removing power to the machine.

To check the file-protect operation, manually depress the file-protect plunger. The file-protect indicator lamp will light and stay lit. Press the reel release switch located just beneath the file reel. The file-protect lamp will momentarily go out. Press the unload key, and the file-protect lamp will go out.

Visually inspect the file-protect plunger for binding and mechanical damage. Inspect the plunger and brake clutch assembly for clearance.

## CLEANING

Clean the file-protect plunger and surrounding area with a clean, lint-free cloth and approved cleaning fluid.

## LUBRICATION

Apply IBM 6 oil sparingly, as required.

## ADJUSTMENT

Bend and form the file-protect relay strap for proper operation when the file-protect plunger is depressed and released. Loosen the relay mounting screws and position the strap in its elongated holes as required.

## REMOVAL AND REPLACEMENT

To remove the file-protect relay, disconnect the file-protect relay wires and remove the mounting screws. To replace, reverse the above procedure.

## Motors

### VISUAL INSPECTION AND OPERATIONAL CHECK

Check all motors for binding shafts. On forward and reverse motors, remove drive belts and spin each motor shaft by hand. They should coast to a smooth stop. Bent shafts can also be detected by turning the shaft through 360° by hand and feeling for sticking or dragging.

Check all pulley and coupling setscrews and taper pins for tightness on the following: drive capstan motors, blower motors, forward and reverse pulleys, high-speed rewind coupling, and the two take-up motors.

All resilient motors have a bond wire across the rubber resilient mounting. The frames of all motors are grounded through a green wire to the machine frame. All motors have a Jones plug for quick disconnecting.

Check all motor plugs for loose connections (Figure 63). Inspect all drive belts for wear. The plug shell is completely insulated inside. All motor leads have a heavy PVC sleeve or tape which extends well down inside the shell and is securely held by the clamp. It is important to make sure that this sleeving is pushed well down inside and clamped after being removed for servicing.

## Relays

### VISUAL INSPECTION AND OPERATIONAL CHECK

Refer to Figure 32 for relay locations.

*Duo Relays:* Check for dirty points, sticky pivots, loose cores, loose contact points and contact piles, and for correct armature-core air gap.

*Wire Relays:* Check for burnt or bent wire contacts, the armature for clearance, the block for tightness (red dust), and the residuals for pound-out.

*Heavy Duty Relays:* Check for free armature movement, dirty contact points, and simultaneous make-break operation.

## CLEANING

Recondition relays by following procedures outlined in the *Customer Engineering Reference Manual, Relays*, Form 225-5857.

## LUBRICATION

Lubricate duo relay operating pads with IBM 17 and the pivots with IBM 6.

## ADJUSTMENT

*Duo Relays:* Set the armature-to-core gap (when open) between 0.017 to 0.019 inch. Set the air gap for all contact points between 0.001 and 0.006 inch when a 0.007 inch gage is inserted between the armature and the brass armature stop pin. See that the gage does not interfere with the rivets holding the phenolic actuating pad to the armature. Use the same gage for making all adjustments.

*Other Relays:* Follow the adjustment procedure outlined in the *Customer Engineering Reference Manual, Relays*, Form 225-5857.

## Filters

### VISUAL INSPECTION AND OPERATIONAL CHECK

Inspect three filters for dirt. One filter is directly above the high-speed rewind motor and the other two are at the bottom of the transistor panel gate. Replace filters when they are dirty.

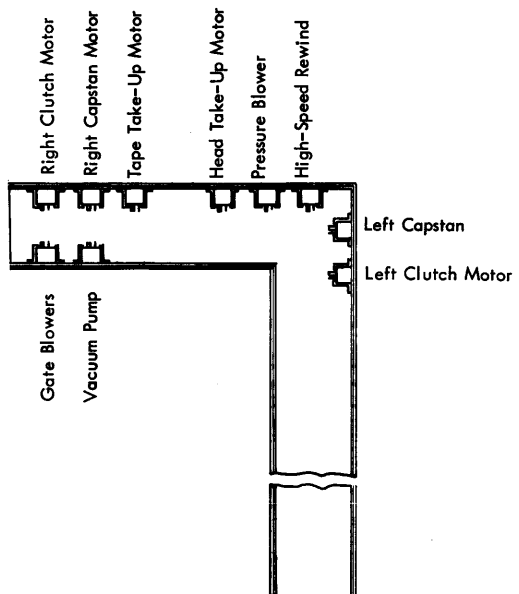

Figure 63. AC Raceway Plug Locations

## Basic Circuit Functions

### Initial Reset

Power coming on a system can cause a random pattern of circuits to be set. Therefore, positive steps must be taken to condition the system for use. The tape unit, when unloaded and not in use, is put in a definite predetermined status, normally by some type of machine reset circuitry.

### Circuit Description

When power is turned on, an initial-reset trigger is set through a capacitor input (Figure 64). This operation places the tape unit in an unloaded condition ready for mounting a reel of tape, as follows:

1. High density is set, according to machine specifications.
2. Machine is placed in read status to inhibit the writing and erasing circuits. Thus no valuable information on tape will be destroyed.
3. If a load-rewind status exists, it is reset.
4. If the unit is not already in a completely unloaded condition, an unload operation is started. A capacitor input resets the unload-stop trigger, allowing the vacuum motors to run until a completely unloaded condition is reached: the head up, tape out of both columns, and the capstans in and not running.

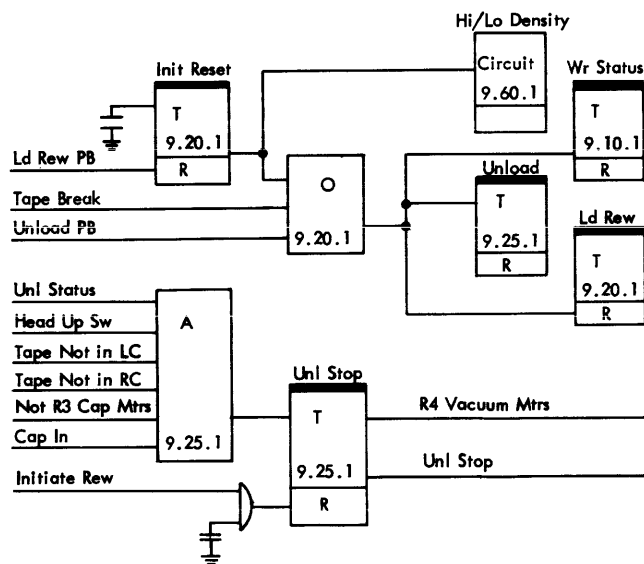

Figure 64. Initial Reset Logic

Figure 64 shows that either a tape break condition, which could occur during a high-speed rewind operation, or an impulse from the unload key, causes all of the same reset functions except the change of density status.

The first use of the load-rewind key resets the initial-reset trigger, and the trigger is not used again as long as power remains on the system.

### Prolay Operation

Tape motion is controlled by two prolays which operate the prolay idlers. Each prolay has three operating positions: stop, go, and neutral. The status of a prolay is determined by energization of one of its three sets of magnet coils. Status of the prolays for various tape unit operating conditions is:

TAPE UNIT STATUS	PROLAY STATUS	
	LEFT	RIGHT
Fwd Stop	Stop	Neutral
Fwd Go	Neutral	Go
Bkwd Stop	Neutral	Stop
Bkwd Go	Go	Neutral

Visualizing the mechanical operation will undoubtedly be more helpful than memorizing a fixed set of conditions. Whenever tape is in motion, it is being pulled across the read-write head, assuring a constant velocity of 75 or 112.5 inches per second. Obviously, pushing the tape across the head, even with good vacuum, would not be satisfactory. To provide forward motion, the right prolay pulls in the forward direction; for backward motion, the left prolay pulls backward. In each case, the opposing prolay is in a neutral status, with its drive capstan out of contact. Stopping tape uses force from the opposite direction: forward motion is stopped by the left prolay, and backward motion by the right prolay; in each case the previously driving capstan is thrown out of contact.

### Circuit Description

A logic diagram of the control circuitry is shown in Figure 65. Although the actual circuitry used in the machine is different, the figure should prove helpful for understanding the operation.

Whenever the tape unit is not in use, it automatically assumes a forward stop status. From the preceding table we note that this prolay status is left-stop and right-neutral. Tracing the forward and stop lines in

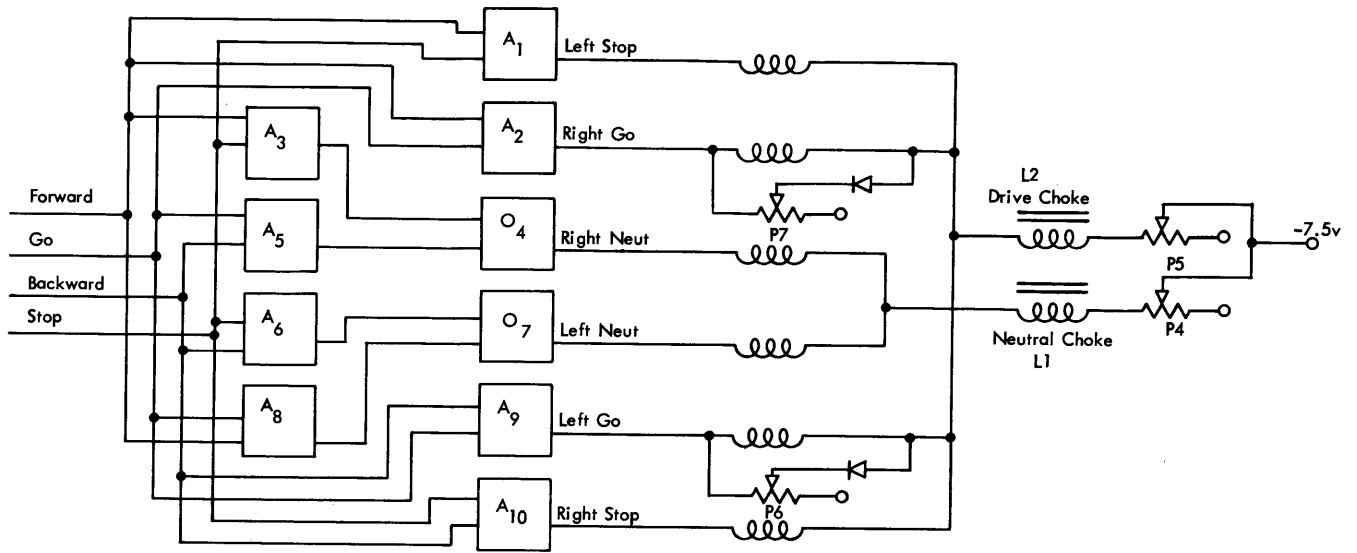

Figure 65. Prolay Control Logic

Figure 65, A<sub>1</sub> and A<sub>3</sub> become active, satisfying our prolay requirements.

When a command is given to move tape forward, the right capstan is energized to pull the tape, while the left capstan is put in the neutral position. Tracing the circuit, A<sub>2</sub> and A<sub>8</sub> become active, again satisfying the prolay requirements. By tracing the backward-go and backward-stop conditions, the rest of the circuitry can be resolved.

The logical circuit of Figure 65 bears little resemblance to the prolay circuitry shown with its associated NOR blocks in Figure 66. Note that negative outputs are required to activate the prolay drivers. To help in determining the outputs, a matrix of forward-backward and go-stop conditions is shown for each output line. The negative are the active conditions, and are shown shaded.

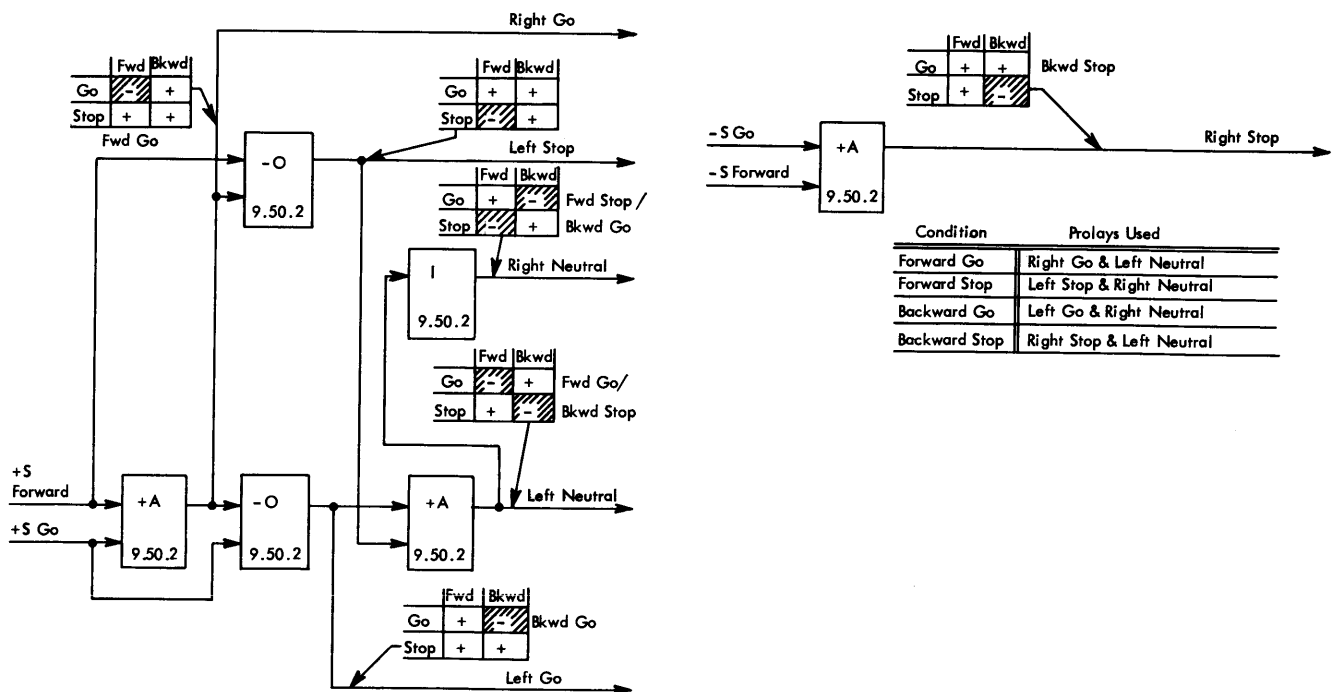

Figure 66. Prolay Control Circuit

## Magnetic Clutch Control

The magnetic clutches must produce an organized movement of magnetic tape for the operation being performed. Six clutches are provided for this purpose: an up, a down, and a stop clutch for both right and left tape reels (Figure 67).

Two sets of circuits determine the movement of the clutches. One set is controlled by the circuit logic and functions when the tape is either unloaded, or being loaded into or unloaded from the vacuum columns. The other set is under control of the vacuum column switches.

### Circuit Description (NOR Logic Control)

Until tape is loaded into the columns, relay 9 (clutch control) is not energized. The normally open points (Figure 67) deactivate the +140v circuit of the vacuum column switch and transfer control to the full and half-brake NOR circuitry.

#### UNLOAD STATUS

With tape in the unloaded status, both reels have full brake applied by  $A_7$  (Figure 68) which mixes "not reel release  $\overline{PB}$ " and "unload brake condition." This is essentially the output of the "unload stop" (Systems 9.25.1).  $O_6$  and  $O_8$  activate full left and right brake, respectively. Full brake goes directly to the left and right stop clutches via relay 9 BU and BL n/c points. The voltage applied will be 0v to -48v for a total of 48 volts.

The reel release key mounted on the front of the unit de-energizes the clutch stop circuit to allow mounting and threading of magnetic tape by the operator.

#### LOAD-REWIND (LOW-SPEED AREA)

Pressing the load-rewind key deactivates  $A_7$  (Figure 68) and picks relay 4 (vacuum motors, Systems 9.25.1). The vacuum bellows switch quickly transfers and picks R1 and R2 (run relays, Systems 9.20.1).

"R1 and R2 run" mix with "tape not in left column" and "tape not in right column" at  $A_1$  and  $A_{10}$  to produce partial brakes. These lines go to the stop clutch (Figure 67) via potentiometers 11 and 10 respectively. The current flowing through the stop clutches is limited by the resistance in the circuit as adjusted by the Customer Engineer.

At this point, the up and down clutches play no part in loading of the tape. Both reels are turned by the tape take-up motor and its associated worm gears which mesh with a fixed gear on the stop clutch (Figure 52).

Partial brake is switched to full brake as soon as tape enters its respective vacuum column. "R1 and R2 run" mixes with "tape in left column" and "tape in right

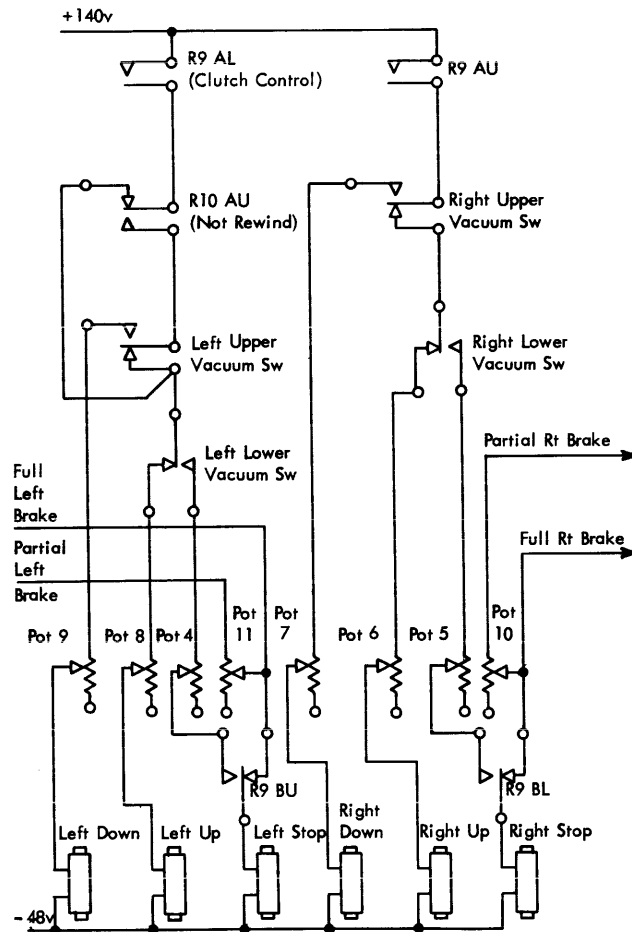

Figure 67. Clutch and Vacuum Control Circuitry

column" in  $A_5$  and  $A_9$  to produce the full brake condition. This circuit remains in effect only, however, until R9 (clutch control) is picked with R3 (capstan motors). At this time control is completely transferred to vacuum switch circuitry.

#### UNLOAD

This is the reverse of the load operation just described.  $A_5$  and  $A_9$  provide full brake until tape leaves the corresponding column, at which point  $A_1$  and  $A_{10}$  apply partial brake until the unloading operation is completed. Once the tape unit is fully unloaded, R1 and R2 drop and "unload brake condition" rises so as to condition  $A_7$ ,  $O_6$ , and  $O_8$  for a full brake.

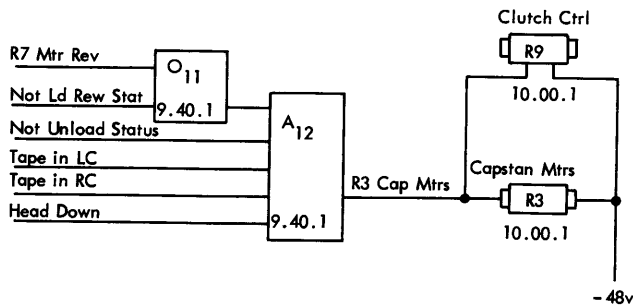

Figure 68. Brake Control Logic

#### HIGH-SPEED REWIND

The high-speed interlock trigger is turned on at the start of a high-speed rewind and remains on until the tape take-up motor begins lowering tape into the columns.

During the high-speed portion of the operation, no electrical brake is applied to either reel. As soon as the photocell recognizes that the machine reel radius has been reduced to  $\frac{1}{2}$  inch of tape, the high-speed rewind status trigger (Systems 9.30.1) is reset. This, in turn, drops relay 5 and opens the high-speed rewind motor circuit. At this point, A<sub>10</sub> applies partial brake to the right reel while the left reel is still free-wheeling. The drag produced by the right brake causes both reels to coast to a smooth halt. Partial left brake is applied through A<sub>3</sub> if tape should enter either column before the tape take-up motor becomes energized.

#### Circuit Description (Vacuum Switch Control)

Whenever tape is in both columns, relay 3 energizes the capstan motors (Figure 68). The clutch control relay, relay 9, picks at the same time and transfers control of the magnetic clutches from NOR logic to +140v vacuum switch circuitry (Figure 67). Note that in the operating condition there is a total of 188v across the clutches as compared with 48v discussed previously.

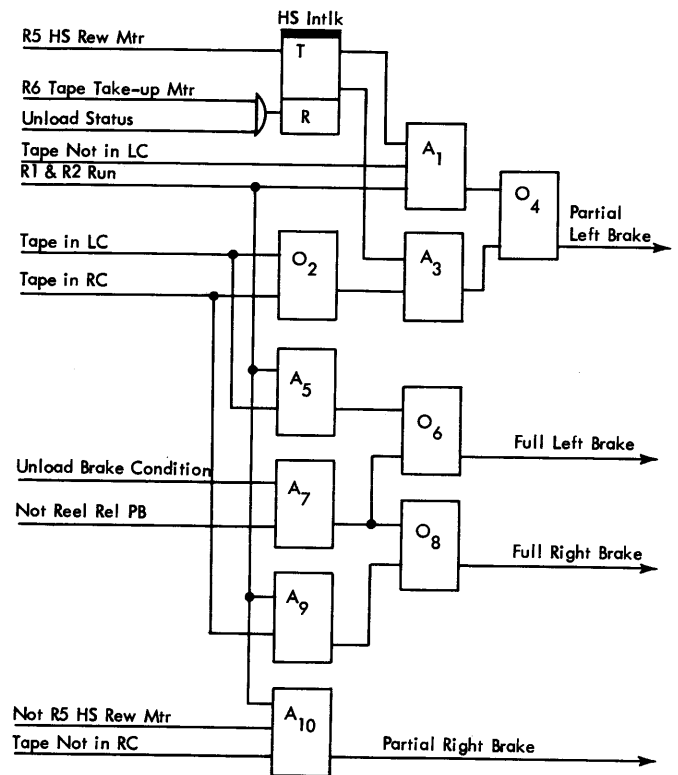

#### FORWARD MOTION

In a forward direction, tape maintains itself about the upper left and lower right column vacuum switches. The left loop rises until the upper vacuum hole in its column is passed. Vacuum then causes the upper switch to transfer, logically energizing the left down clutch to feed more tape from the file reel. The circuit consists of +140v, relay 9 AL N/O, relay 10 AU N/O, left upper vacuum switch N/O, potentiometer 9, left down clutch, and -48v.

As tape is lowered in the column, the upper vacuum hole is passed, and atmospheric pressure is returned to the upper switch. At this time the points return to their normal position, transferring control to the left stop clutch as follows: +140v, relay 10 AU N/O, left upper vacuum switch N/C, left lower vacuum switch N/O, potentiometer 4, relay 9 BU N/O, left stop clutch, and -48v.

With the tape maintained in position about the upper vacuum hole, the lower vacuum switch has vacuum and therefore is in the transferred condition. The switch in this position completely eliminates the left upper clutch, because tape should be fed only into the left column and not out of it.

On the right side, tape maintains itself about the lower vacuum column hole. The loop of tape is lowered into the column as tape is fed across the read-

write head by the capstans. In order to remove the tape from the column and wind it on the machine reel, the right up and stop clutches are used. Because the right upper vacuum switch remains in a normal condition, its N/O points completely eliminate the right down circuit (Figure 67).

#### BACKWARD MOTION

When tape is driven backward by the capstans, the loop tends to rise in the right column and lower in the left. Logically, then, the right down clutch must feed tape from the machine reel while the left up clutch winds the tape on the file reel. The stabilizing points will now be at the right upper and left lower vacuum column holes. With this information it should be simple enough to trace the appropriate circuit paths on Figure 67.

#### LOAD REWIND

A load rewind operation first lowers tape into the columns by means of the tape take-up motor in reverse, and then conditions the prolays for backward go. Backward movement, as has been explained, causes tape to position itself at the lower left vacuum hole.

During the loading part of the operation, both relay 3 (capstan motors) and relay 9 (clutch control) pick as soon as tape enters the tops of the columns and produces vacuum. At this time, the left upper vacuum switch transfers and attempts to energize the left down clutch. At the same time, both capstans are feeding tape into the left column. Tape coming in from both directions could very easily result in a loop that would extend too far below the lower hole and into the manifold screening. If this happened, the vacuum bellows switch would transfer and drop ready status on the unit.

To prevent this condition, a rewind operation opens the circuit to the left down clutch as tape is entering the columns. In Figure 67 note that the relay 10 AU N/C points bypass the left upper vacuum switch.

#### File Protection

Customers' program and data tapes are valuable property. They may contain information which is difficult or impossible to recreate. With this in mind, it is essential that every precaution be taken to protect them from being destroyed.

The file protection circuit is designed to prevent writing on tape. By removing a plastic ring which fits in a groove in the rear of the tape reel, an operator may cause the writing circuits to be disabled. Absence of the ring from the reel file-protects the machine, and is fail-safe: if the ring should fall out, the file is

automatically protected. Placing the ring in the reel allows writing. Reading can be accomplished with or without the ring.

#### Circuit Description

Two duo relays (Figure 69) are used in conjunction with the file protect circuits. Because relays can burn out, points become burned or dirty, and components malfunction, causing circuit discontinuity, fail-safe file-protect status consists of relays in normally open or dropped-out condition. Any circuit failure, then, will tend to protect the file.

To write on tape, a plastic ring is placed in back of the reel. The ring pushes a plunger which mechanically actuates a relay armature, transferring the relay 12 AL points; the BL points have a relatively wide air gap and are not closed by the plunger operation.

In the normally unloaded status, with no reel on the machine, relays 12 and 11 are dropped out and the file protect light is lit through relay 11 AL N/C. When a reel is mounted on the machine with the plastic ring installed, the plunger rides on the ring and closes the relay 12 AL N/O points. Relay 12 will not pick because the unload stop trigger is on.

When the reel release key is depressed to permit threading the tape, relay 12 is picked and the plunger is withdrawn from the ring, to prevent its bending or

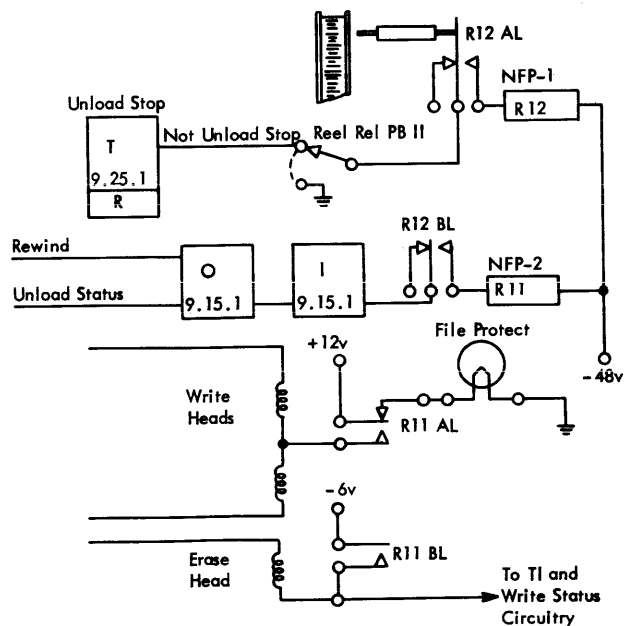

Figure 69. File Protection



the scraping of bits of plastic into the transport mechanism. Relay 11 will not pick because the machine is in an unload status.

Pressing the load rewind key resets the unload stop trigger and picks relay 12. The extra mechanical movement of the armature closes its BL points and conditions the circuit for relay 11. Notice that relay 11 does not pick, however, while the tape is rewinding to load point. Thus, when tape is rewound, the erase and write heads are prevented from destroying information. At load point, relay 11 picks, turning off the file protect light and conditioning both the write and erase heads through its AL and BL N/O points.

### Read Circuit

The read circuitry recognizes a flux change on tape by a small voltage induced in the read head coil, amplifies it to a usable level, and makes it available to the controlling unit.

#### Circuit Description

The read head coil (Figure 70) recognizes changes in flux in the moving tape and sends a stream of pulses into the preamplifier. A delay line compensates for

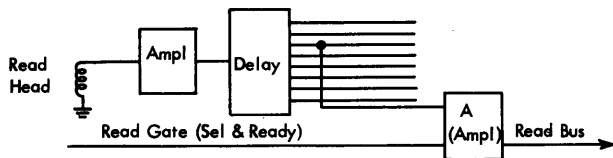

Figure 70. Read Circuit

read skew, so that pulses from all tracks will be available simultaneously. The final output of the preamplifier is gated at  $A_1$  by "read gate," which allows pulses to reach the read bus only when the tape unit is selected and ready.

### Writing Circuit

The write circuits feed current to the appropriate write heads to produce recognizable flux patterns on tape. Writing is controlled by an external unit which determines the track or tracks to be used, as well as the bit density. Echo pulses, generated by the writing circuit, are fed back for use by the external device. A file is protected by opening of the write circuits whenever a file reel does not have a plastic ring inserted.

#### Circuit Description

Signals which are generated in the external control, such as write pulses, write bus, and write check character, are available to all connected tape units. "Select and ready" conditions  $A_1$  and  $A_2$ , isolating the operation to the particular tape unit. See Figure 71.

In order to compensate for the various causes of write skew, the write pulse is fed into delay line circuitry. Choosing the appropriate output for each track enables all tracks to write simultaneously with respect to read head output. The write pulse is fed into the trigger via  $A_3$ ; if conditioned by its particular write bus, the trigger flips and causes current to reverse through the write head coils. The driver, as a result of the current reversal, will cause an echo pulse to be generated.

To write a check character, the trigger is reset by the negative level at  $A_2$ . Notice that  $A_2$  conditions  $A_3$  and has output up only when selected. Whenever the tape unit goes out of select,  $A_3$  is deconditioned, thus

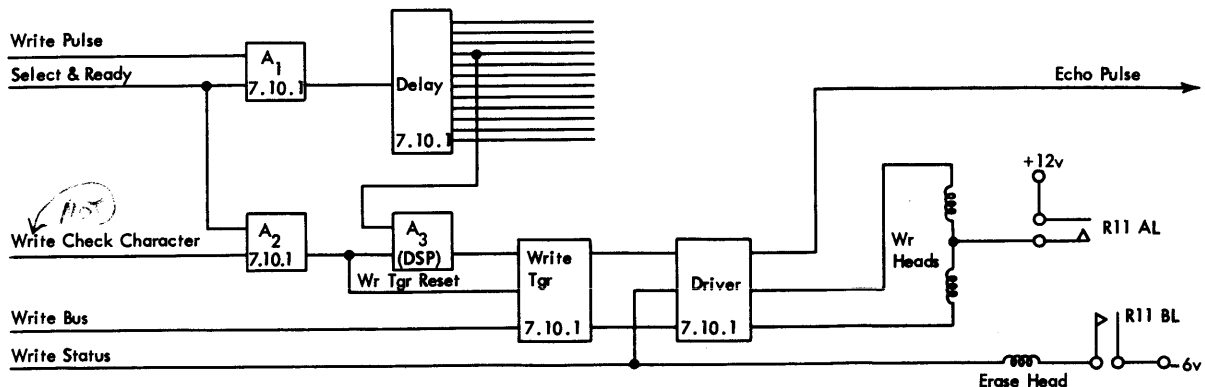

Figure 71. Write Circuit

helping to prevent any noise from affecting the write trigger when the head is in the inter-record gap.

File protection safeguards the circuits not only by the relay 11 points, but also in the "write status" line and its generation shown on Systems 9.10.1. For a more detailed explanation of the write circuit see the section on special component circuits.

### High-Low Density

The 729 II and IV tape units write or read tape at two different densities. The densities of the various tapes attached to a system may be mixed; therefore, each unit must determine and remember its own status. When the tape unit is selected, it notifies its controlling device so that characters will be transmitted at the proper rate.

The NOR density circuitry is essentially a DC binary trigger (Figure 72). In addition to alternating density status with each depression of a key, it must also set specific conditions under initial reset or program control. Some of the circuitry functions only during specific operations. Figure 73 shows only the circuitry which is active under reset and external control; Figure 74 shows only the active circuitry for manual key operation. Figure 72 shows both; note that active portions, during their operation, do not affect the non-active portions.

### Circuit Description

#### DENSITY CONTROL TRIGGER

The density control trigger functions to eliminate electrical noise due to contact bounce, thus helping stabilize the circuit transition from one density to another. The normal position of the change density key applies  $-12v$  at point C of the  $-TO$  block. This raises the output E; with point F floating, the output of the trigger at point D will be at a  $-S$  level.

When switch 1 opens, point C floats. Electrical noise will have disappeared from C before point F is lowered to  $-12v$ . When switch 2 closes, points D will go to  $+S$ . This immediately lowers points E, and latches the trigger. Any electrical noise remaining at point F will have no further effect since E is now holding the circuit.

In summary, the static output of the density control trigger (points D) is  $-S$ . Depressing the change density key changes this output, maintaining it at  $+S$  until the key is released.

#### INITIAL RESET

Initial (power-on) reset unconditionally sets the tape unit to high density. During this operation, both J and K (Figure 73) remain at a  $+S$  level. Initial reset drops to a  $-S$  level which in turn brings the output M of  $O_7$  to  $+S$ . M now feeding back to  $O_8$  causes output N to drop to a  $-S$  level. This, then, maintains the

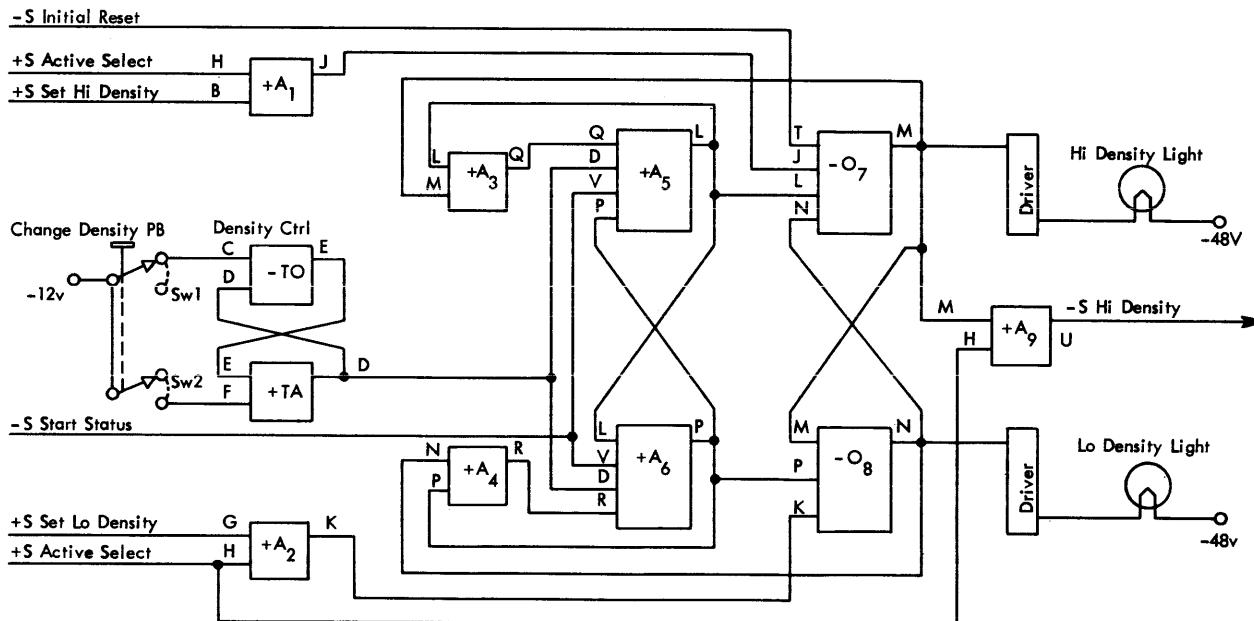

Figure 72. High-Low Density

established condition on  $O_7$  and also extinguishes the low density light. Point N will hold the tape unit in high density even though the initial reset condition may be removed at a later time.

#### HIGH-LOW PROGRAM CONTROL

Figure 73 shows the essential circuits for program control of density. Assume high density status. A change to low density will result from a signal received from the controlling device. Before this can become effective, however, the tape unit must be selected. Selection conditions  $A_1$  and  $A_2$  so that the "set low density" line at G causes K to fall to a  $-S$  level. This is fed into  $O_8$ , causing N to rise and lighting the low density light. N, at the same time, feeds into  $O_7$ , causing M to drop to a  $-S$ . M at  $O_8$  now holds low density, even after the initial pulse at K has disappeared.

By following the same logic at  $A_1$  for "set high density," it is seen that low density can be reset and replaced by a high density status.

#### HIGH-LOW KEY CONTROL

The density circuit for key operation (Figure 74) is essentially a DC binary trigger. Its status will be changed with each depression of the change-density key. One major controlling line is "start status." The machine must be out of ready (start) status for the key to be operative. With this in mind, note that points V will be at  $+S$  level throughout the entire operation, and thus can be eliminated from the discussion.

There is a certain symmetry of the circuit which might be thought about in the following manner:  $O_7$  and  $O_8$  determine the final status by bringing either points M or N to a  $+S$  level. Two controlling blocks,  $A_5$  and  $A_6$ , effect a change in the status of  $O_7$  and  $O_8$  under control of line D from the density control trigger and its associated key.  $A_3$  and  $A_4$  are essentially gate switching devices letting line D alternately affect  $A_5$  and  $A_6$ .

Assuming that high density is set, M is at  $+S$  while N is at  $-S$ . Line D (normally  $-S$ ), feeding into  $A_5$

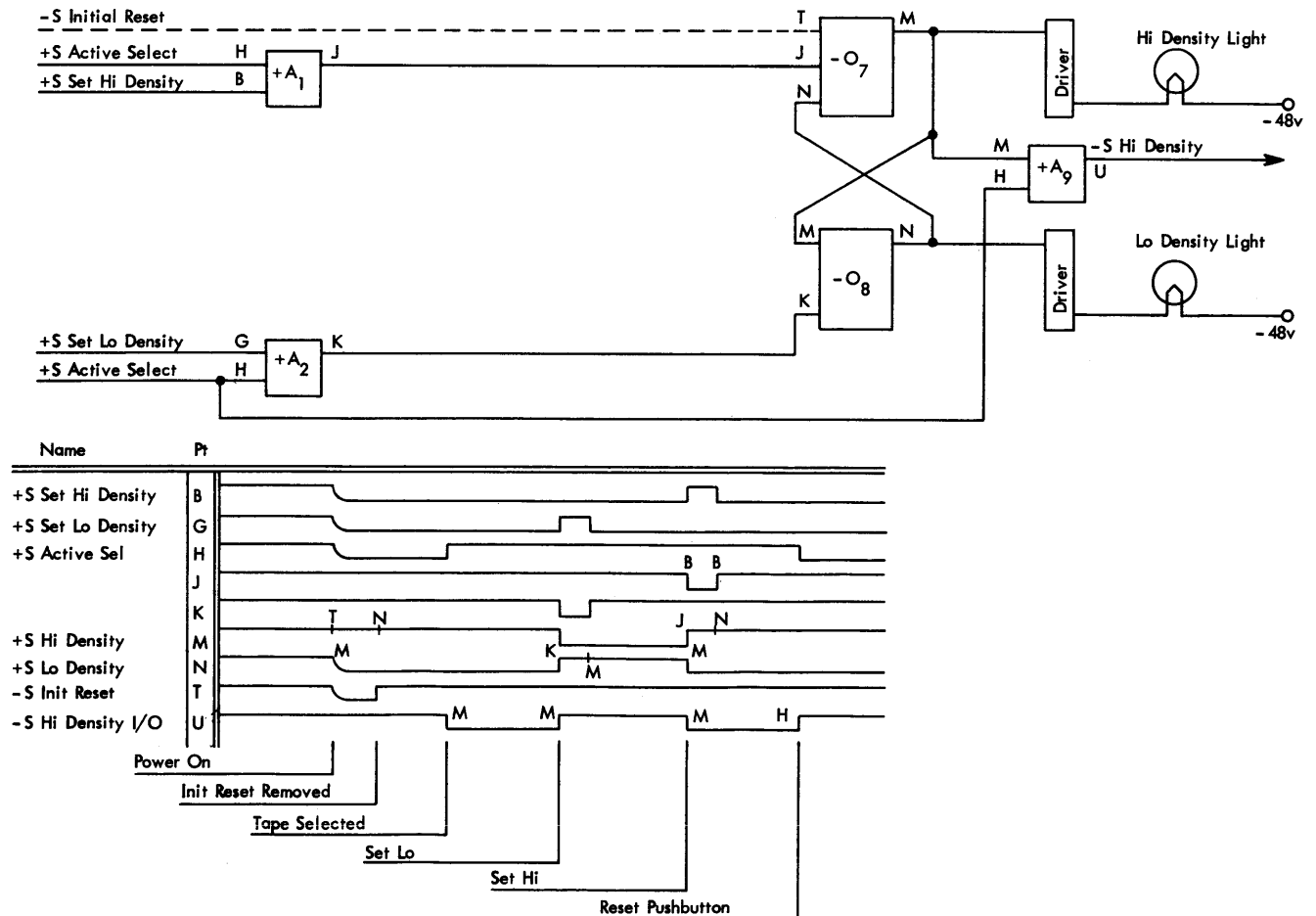

Figure 73. High-Low Density (Reset and External Control)

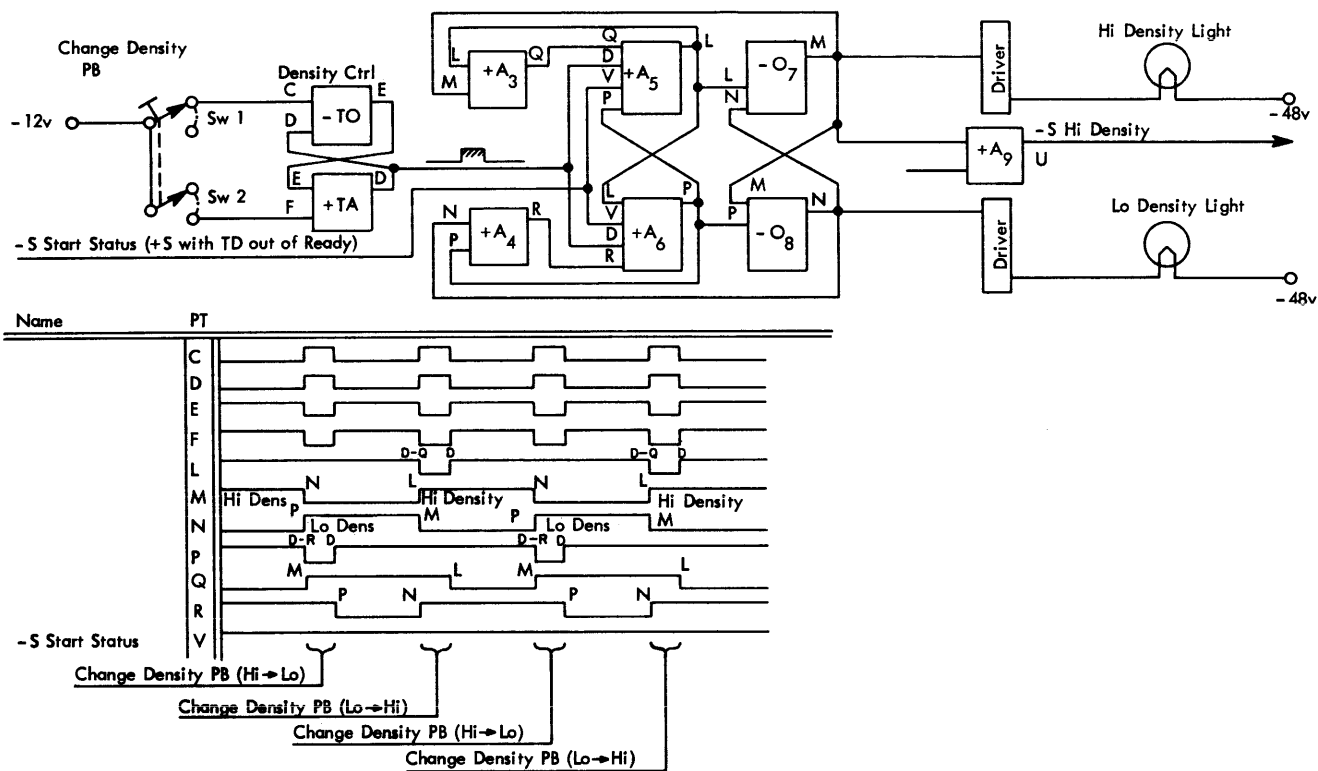

Figure 74. High-Low Density (Key Control)

and  $A_6$ , causes both points L and P to be at +S. These four lines feeding into  $A_3$  and  $A_4$  produce a -S at Q and a +S at R.  $A_3$  deconditions  $A_5$  for the next depression of the key. The +S level of R will gate the next key pulse into  $A_6$  (all four inputs +S), dropping point P to -S at  $O_8$  and causing the trigger to flip from high density status and latch into low.

Low density status drops R and raises Q, so that  $A_5$  is now gated and  $A_6$  deconditioned. The following plus pulse on line D activates  $A_5$ , drops L to -S, and therefore raises point M, producing high density. M, of course, drops N through  $O_8$  and extinguishes the low density light.

### Load Point

The system circuits as well as the programmer need to know when the file reel is at the beginning of tape (load point). A trigger in the tape unit remembers and will indicate this fact when tested by subsequent operations. A photocell and lamp combination is used in conjunction with a load point reflective spot to detect the desired condition.

The reflective spot is placed on the glossy side of the tape about 10 feet from the physical beginning and 1/2 inch from the front edge as viewed looking at a reel mounted in the machine. The lamp and photocell are mounted close to the read-write head (Figure 75). When the strip passes across the head, light from the lamp is reflected into the cell. The load point trigger is then set until the tape is removed from its load point position.

### Circuit Description

The load point lamp is lit only when the machine is fully loaded with tape in both columns as indicated by "R3 capstan motors," which activates the driver circuit to apply necessary voltage to the lamp. R20, a 150 ohm variable resistor mounted in the motor control box, allows adjustment of light intensity. See Figure 75.

As tape moves backward during a backspace, rewind, or load rewind operation, light from the load point lamp is reflected by the aluminum strip into the load point photocell. As a result of this, a 10μs pulse is generated and combined with "backward" and "go" ( $A_1$ ), turning on the LP trigger. The output of this trigger is then sampled to determine the physical position

of tape on the machine. Notice that the trigger will remain on until tape is moved forward from load point, as determined by a forward-go condition in A<sub>2</sub>. Unloading the tape unit will also turn off the trigger and hold it reset until another load-rewind operation is initiated.

### Tape Indicate

The tape indicate trigger is available to the attached system for interrogation, and may be used to indicate a physical condition within the tape unit itself, or for other purposes connected with the customer's program.

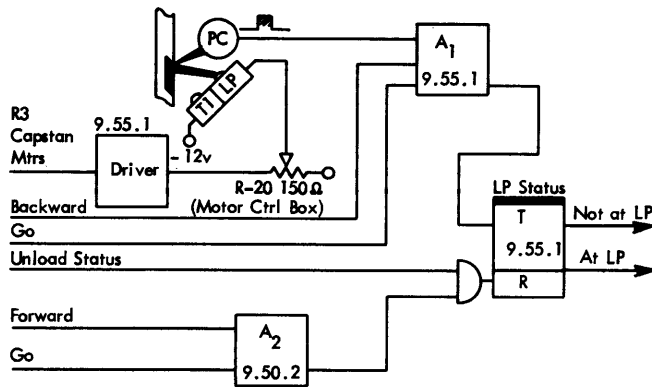

Figure 75. Load Point Logic

### Circuit Description

The tape indicator trigger is turned on, during a write operation, as soon as the end-of-tape reflective spot passes under the tape indicate lamp and photocell. A<sub>1</sub> turns it on when the 10 $\mu$ s pulse is emitted by the photocell and its associated circuitry (Figure 76). In this case, the trigger's coming on is a sign to the system that the end of tape is near; it is only an indication, and does not hinder the writing operation. A program, ignoring this, would pull the tape off of the takeup reel as writing was continued. Therefore the program, recognizing EOT, will logically close the file, and turn off the indicator through A<sub>3</sub>.

Sometimes, in programming, it is convenient to pinpoint a particular tape unit. With this in mind, note that A<sub>2</sub> can turn on the tape indicator upon an external signal, which may originate in either external circuit conditions or program control.

Finally, the tape indicate trigger is turned off as the result of an unloading operation.

### High-Speed Rewind Sensing

Tape will be removed from a high-speed rewind condition if any of four logical conditions exist:

1. There is less than 1/2 inch of tape on the machine reel. This condition is sensed by the photocell and

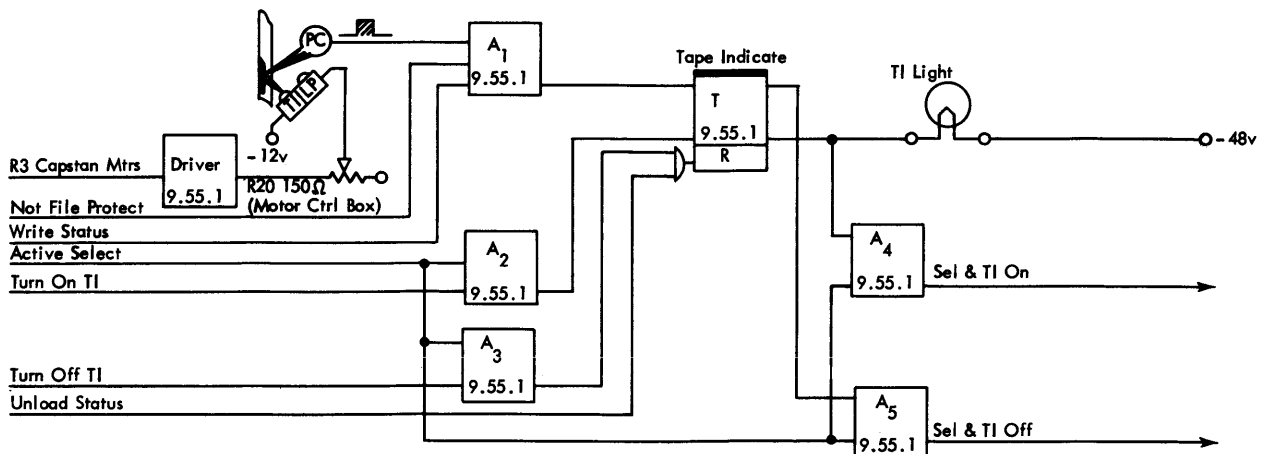

Figure 76. Tape Indicate Logic

lamp arrangement shown in Figure 77. The lamp, mounted in the upper right-hand corner of the tape unit, is beamed between the sides of the machine reel so that it strikes the photocell mounted in the finger guard. When the tape builds up on the machine reel, light beam to the cell is blocked.

2. The high-speed rewind lamp is burned out. This condition is continuously monitored by machine circuits as explained below.

3. Tape breaks during a high-speed rewind operation. Light from the tape break lamp is directed toward the load point photocell. Should tape break, light will strike the cell and produce a machine reset. This, in turn, resets the high-speed rewind trigger. For more details, see the section on tape break circuit description.

4. The high-speed rewind thermal switch has been tripped by a faulty or overheated motor. This switch is physically mounted within the casing of the motor.

The logic of these conditions is shown in Figure 78. Bear in mind that the high-speed rewind trigger is set only at the beginning of the rewind operation ("initiate rewind"). If any one of the reset conditions is present at that time, the trigger cannot be turned on and a high-speed operation cannot take place.

If the trigger is turned on at the start of a rewind operation, it remains on until reset by one of the conditions. Normally this will occur when the photocell circuit senses 1/2 inch of tape.

With less than 1/2 inch of tape on the machine reel, light reaches the photocell and reduces the resistance of the cell, causing it to conduct quite heavily. The drop across resistor R13 places a negative voltage at the top leg of the +A circuit, causing its output to remain positive. The inverter, in turn, applies a minus level to the trigger, holding it reset. As tape fills the machine reel during a read or write operation, it will slowly cut off the light to the photocell, causing resistance to increase, current to decrease, and the voltage at point X to rise toward plus 12v at the upper leg.

Thus, a burned-out lamp would, in effect, cause the machine to think it is in a high-speed area with more than 1/2 inch of tape on the machine reel. Because of this, and also to allow adjustment of the lamp intensity, additional circuitry is involved, as shown in Figure 77.

With the lamp filament intact, 18 volts is applied across the lamp and adjustable resistor. Because the lamp resistance is small compared with R19, point Y is positive and will have no reset effect. An open filament brings point Y down to -12v, deconditions the +A circuit, and holds the trigger continuously reset.

### Circuit Description

Figure 78 shows the over-all logic of the high-speed rewind, whereas Figure 77 shows the actual circuitry connected with the photocell and lamp. A minus level into the reset section of the trigger prevents any turning on of the high-speed rewind trigger at the start of a rewind operation. The reset will occur, then, if either one of the inputs to the +A circuit rises to a plus level.

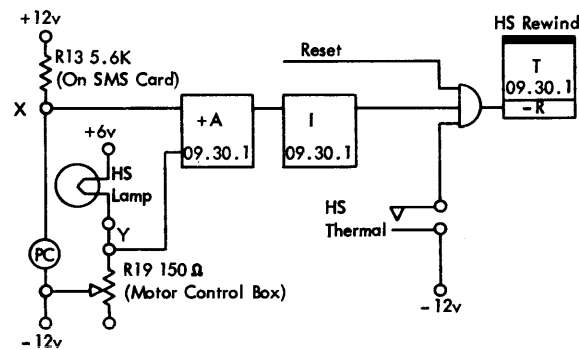

Figure 77. High-Speed Rewind Lamp

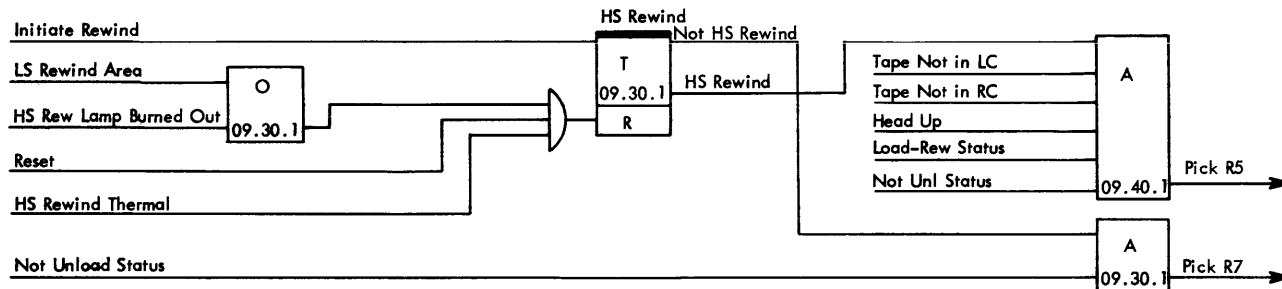

Figure 78. High-Speed Rewind Logic

## Tape Break

It is possible for tape to break during a high-speed rewind when the reels are spinning at a high velocity. This could result from a faulty drive, poor condition of the tape itself, or improper mounting by the operator. Throughout the high-speed period of the rewind there is no electrical brake applied to either of the machine reels. A break at this time could result in a great deal of additional damage to the tape itself if it were allowed to flap against the inside framework of the machine. To prevent this, a photocell and lamp combination will sense the break, whereupon full electrical brake is applied immediately to both reels. In addition, the machine is returned to a normal unloaded condition.

### Circuit Description

The tape-break lamp is mounted in the tape cleaner assembly and directed at the load-point photocell. As can be seen in Figure 79, the lamp is lit only when the capstan motors are not energized, that is, when the

tape unit is either unloaded or in process of a high-speed rewind.

With tape passing between the lamp and photocell, no light reaches the cell to cause an output. If tape breaks, however, light strikes the cell, causing a 10- $\mu$ s positive pulse output.

After tape has been raised out of the columns, relay 5 (high-speed rewind motor) is picked and the high-speed interlock trigger is turned on. Note that the trigger is reset by "R6 tape take-up motor" when relay 6 is picked to start loading tape back into the columns again. From this we see that the trigger will gate only the high-speed area of the operation. The trigger output brings up "internal go" by conditioning O<sub>2</sub> which, in turn, conditions A<sub>3</sub> mixed with "backward."

The pulse from the photocell circuitry mixes with "backward" and "go" in A<sub>5</sub> and produces "gated LP PC." This mixes at A<sub>6</sub> with "high-speed rewind interlock," and through O<sub>7</sub> turns on "unload status." At this point A<sub>8</sub> becomes active, not only turning on the unload stop trigger but also immediately forcing full left and right brakes through A<sub>9</sub>, O<sub>10</sub>, and O<sub>11</sub>.

At this point, the reels have come to a complete stop and the tape unit is restored to a normal unloaded status.

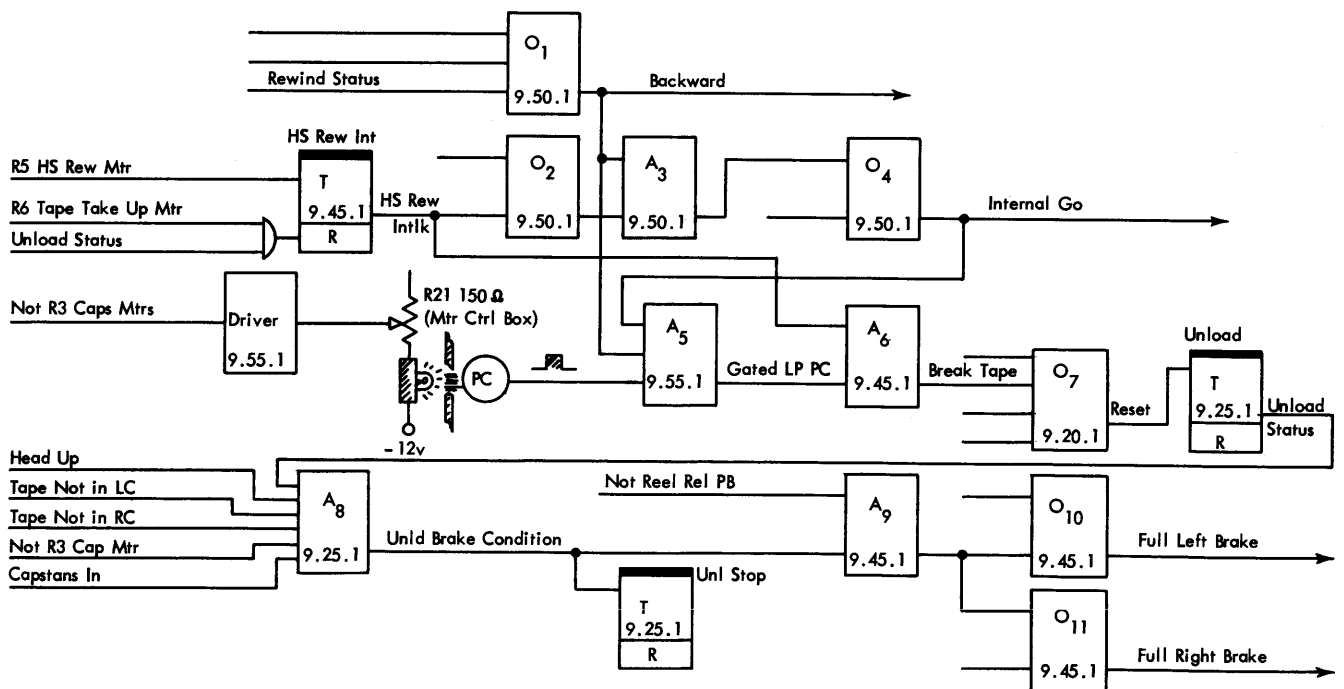

Figure 79. Tape Break Logic

## Machine Operations

### Load Rewind

As the name implies, the object of this operation is to load the tape properly from the file reel into the transport mechanism; and to rewind it to load point, ready for system operation.

Pressing the load-rewind key starts two distinct operations: (1) loading the tape into the vacuum columns and across the read-write head, and (2) rewinding the tape to load point. The rewinding operation is conditioned on pressing the key, but does not actually begin until the last sequence of the load operation is completed. Because the tape might be in a high-speed area, a test must first be made to determine the course of events at this point. Also, before any phase of the operation can begin, the machine must be placed in read status with all write and erase circuitry inhibited. If these precautions were not taken, valuable information might be destroyed.

#### Circuit Description—Low Speed (Figures 80, 81, 82, 93)

Before the load-rewind key can affect the circuit, the machine must be out of start status; otherwise an accidental load rewind could occur during computer operation. Gating for this condition, as well as the starting point of the operation, will be found on Systems 9.10.1 with "gated ld rew RB." The immediate result of this pulse is to reset the write status trigger, if on, to assure removal of the write heads and erase head from the circuits. For an explanation of this and the picking of relays 11 and 12, see the section on file protection. Mixing the off condition of write status with the remainder of the key pulse produces "initiate rew" and allows the operation to proceed.

"Initiate rew" (Systems 9.25.1) resets both the unload and unload-stop triggers, and the turning off of unload-stop unconditionally picks R4, starting the vacuum motors. While vacuum is being built up in the manifold, several other operations occur.

An attempt is made to turn on the high-speed rewind status trigger (Systems 9.30.1). Since less than  $\frac{1}{2}$  inch of tape is on the machine reel, the trigger is held reset and the initiate rewind pulse has no effect. See the section on high-speed rewind sensing for further details. Because both the tape and head must be lowered during this operation, relay 7 (motor reverse) is picked to reverse the phases and direction of the tape take-up and head-up motors. Relay 7, at this point, conditions

only the 3-phase input circuitry; the motors themselves are picked after other conditions have been met.

"Initiate rewind" sets two more triggers: load-rewind and rewind. "Rewind status" feeds circuits shown on Systems 9.50.1 which immediately drop "forward" and condition the prolay circuits for backward movement. Final conditioning involves "internal go," which is not available until tape is fully loaded and the capstans are extended and energized. "Rewind status" also drops relay 10 (not rewind status), removing the left down clutch during the loading operation. For a further explanation see the section on magnetic clutch control.

As soon as vacuum rises in the manifold, the bellows switch opens (11.00.1) and mixes with "load-rewind status" (9.20.1) to pick R1 and R2 run relays. These double pole relays complete circuits to the forward and reverse clutch drive motors to start them turning. Power is furnished also for the rewind, capstan, tape take-up, and head-up motors so that they can operate when their corresponding relays are energized.

The next operation loads tape into the columns. Note that the tape take-up motor trigger (9.35.1) has one set line and several reset conditions. "Reel stopped," which indicates that the machine is not in a high-speed rewind condition, continually tries to turn on the trigger. Here, vacuum is the controlling factor. The bellows switch, transferring, removes the only active reset and allows relay 6 (tape take-up motor) to pick. The motor runs in reverse, and through worm gears on the stop clutches, drives both the file and machine reels, lowering tape into the columns. This operation continues until the trigger is again reset, by "load gate" conditioned by "tape in both columns" and "R7 motor reverse." The last condition essentially signifies a load operation.

The head motor trigger is turned on by the output of the tape take-up motor trigger mixing with "tape in one column" and "R7 motor reverse" (9.35.1). Note that the head does not start down until the tape has been lowered into at least one of the columns. This condition assures that the tape is properly positioned across the transport area, and will not be pinched when the head is lowered. The motor continues to run until the head down switch closes, resets the trigger, and drops relay 8.

As soon as tape is down in the columns, the capstan motors (9.40.1) can rotate and extend themselves in



Figure 80. Load-Rewind Flow Chart

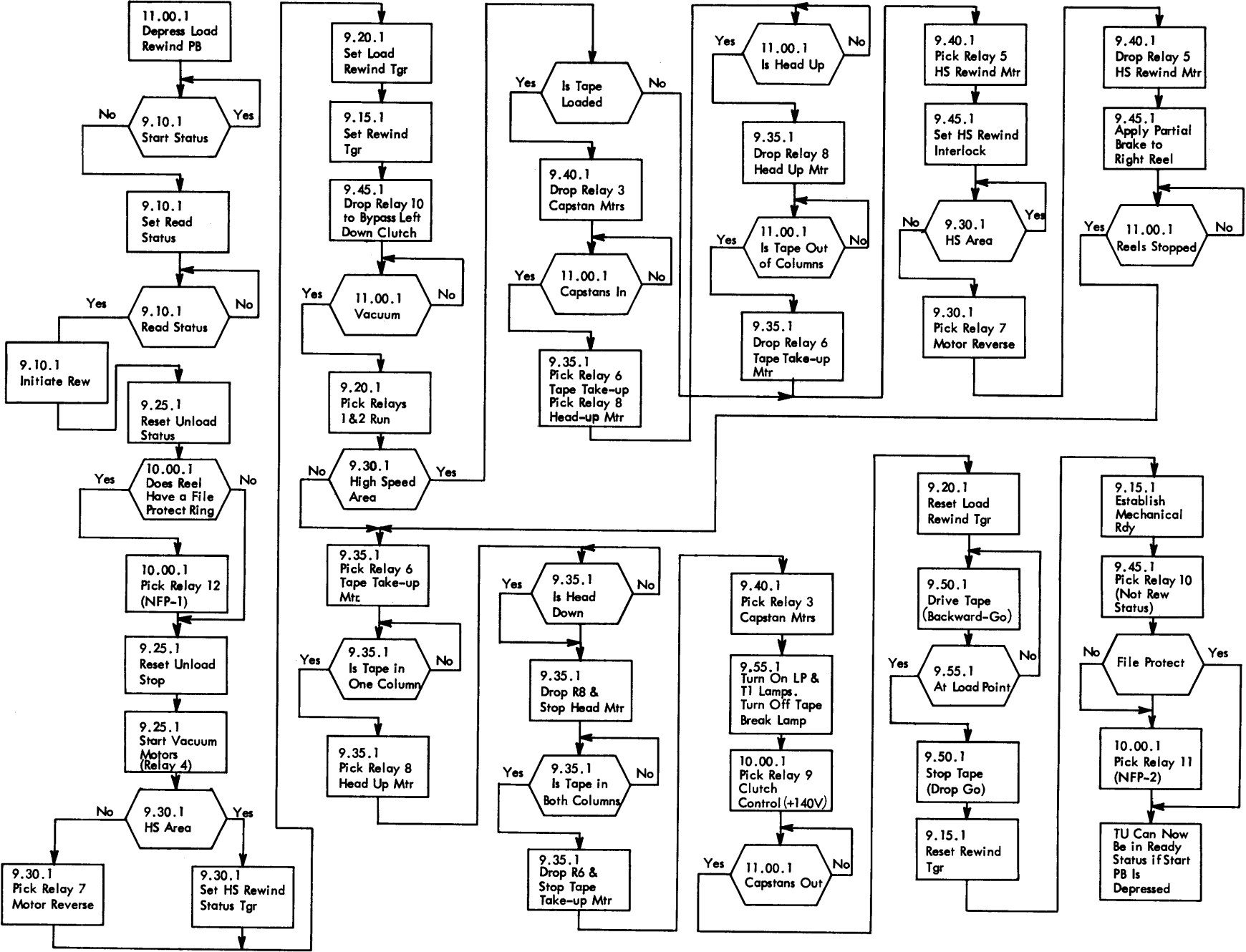

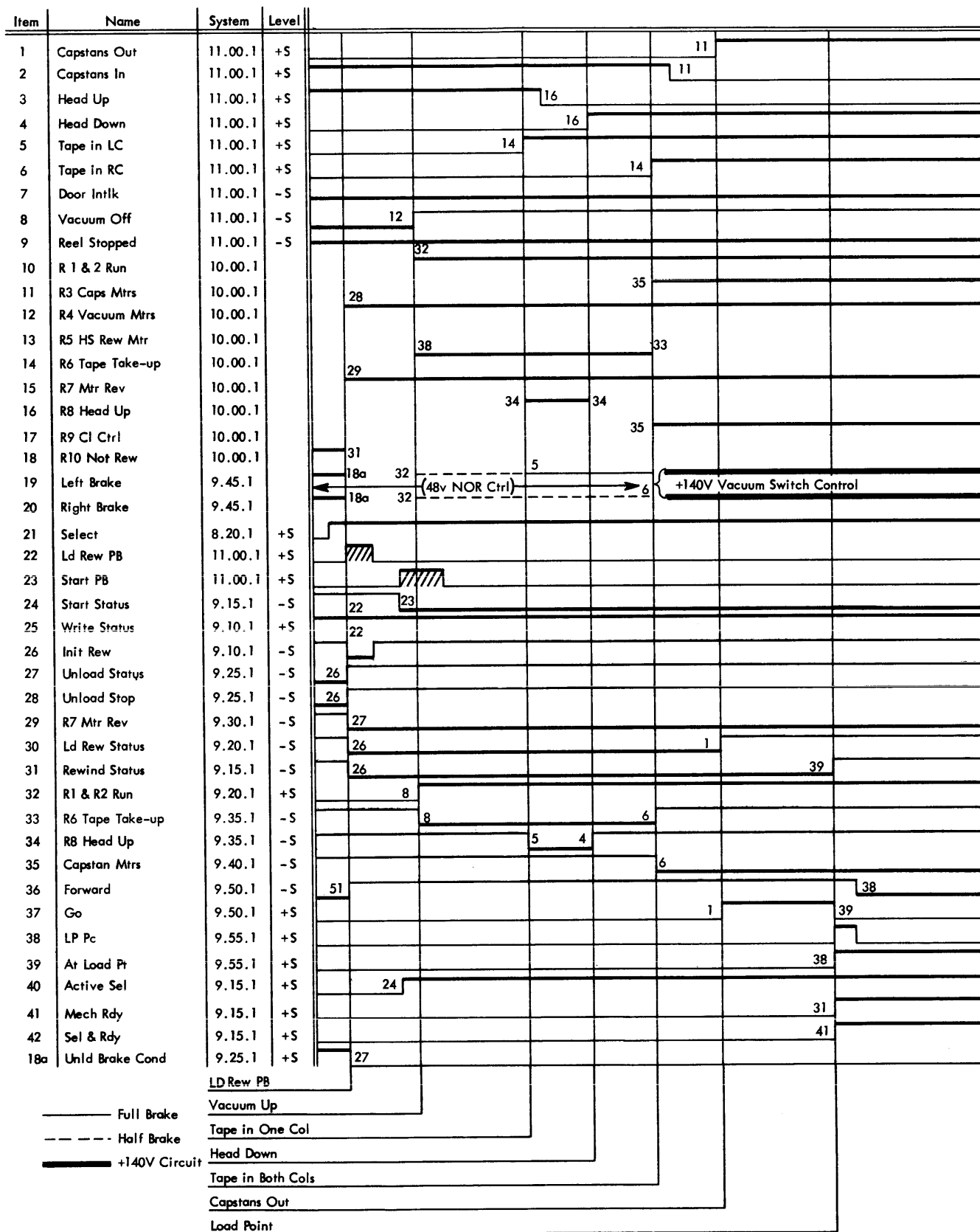

Figure 81. Load-Rewind Sequence Chart (Low Speed)

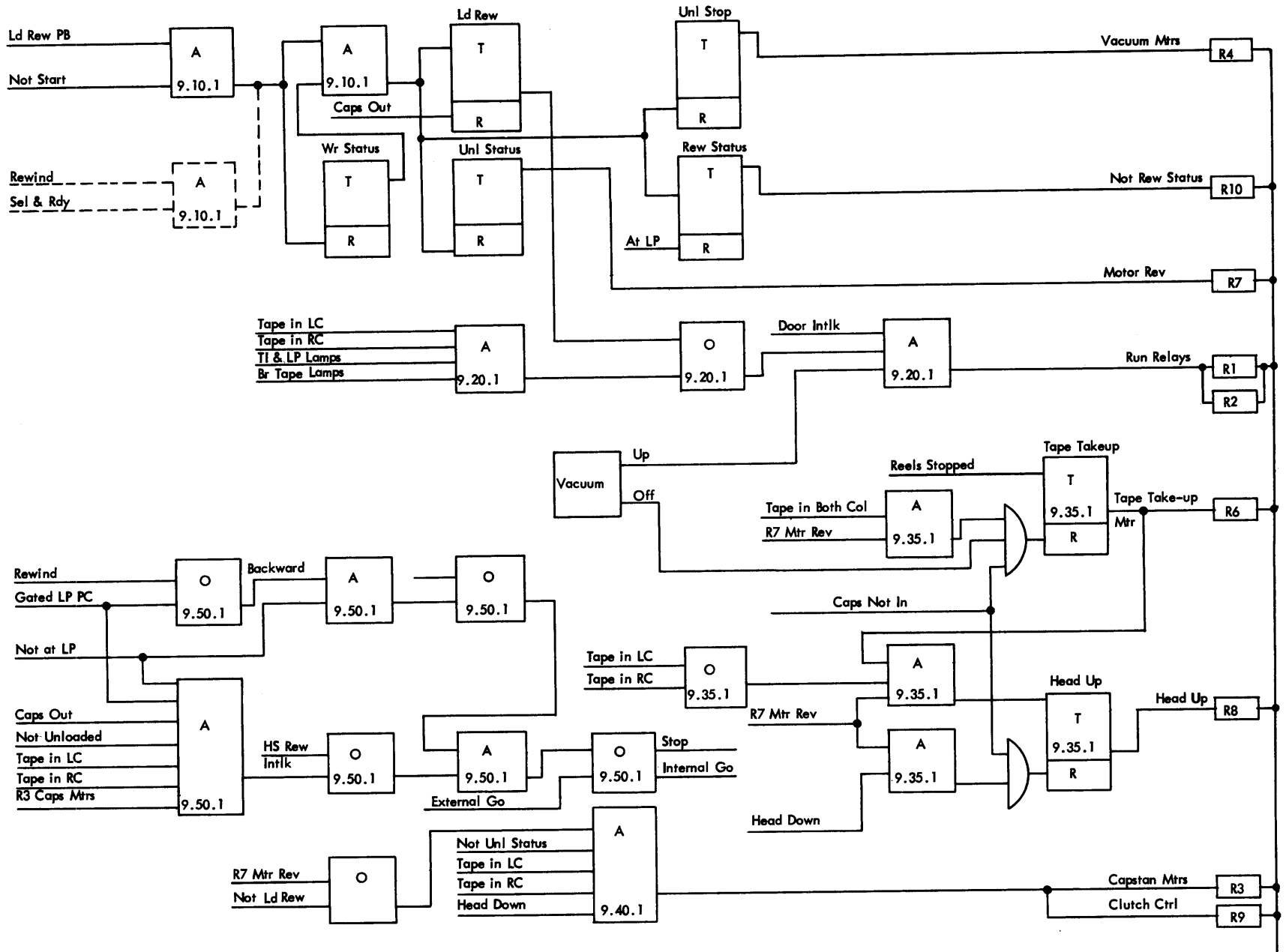

Figure 82. Rewind and Load-Rewind Condensed Logic (Low Speed)

line with the prolay idlers. These conditions now obtain: head down, tape in right and left columns, not unload status, and R7 motor reverse; therefore "capstan motors" becomes active and picks relay 3.

At this point, relay 3 (capstan motors, 9.55.1) turns off the tape break lamp and turns on the load point and tape indicate lamps in preparation for recognizing load point during rewind.

Relay 9 (clutch control, 10.00.1) picks with relay 3 (capstan motors) and transfers clutch control from the 48 volt NOR logic to the +140 volt vacuum column switch circuits. For further explanation, see the section on clutch control.

As the capstan motors begin to turn, the capstans extend into the columns and close their corresponding out switches. These two switches in series turn off the load-rewind trigger (9.20.1), signalling the end of the loading phase of the operation.

The rewind phase now can begin. It will consist primarily of driving the tape backward until load point is recognized. "Rewind status" has previously established backward ("not forward internal," 9.50.1). "Rewind status," mixing with the following logic, brings up go internal: not at load point, tape in left and right columns, and both capstans out and running; the final condition is "capstans out." "Backward-go" energizes (9.50.2) the left-go and right-neutral prolay combination to produce the required motion. For a further explanation of prolay logic, see the section on prolay operation.

The load-point reflective spot, passing the read-write head, causes a 10- $\mu$ s pulse to be emitted at the photo amplifier (9.55.1). The rise of this pulse, mixing with "not forward" (backward) and "go," turns on the load point status trigger. "At load point" turns off the rewind trigger (9.15.1) and drops "go" (9.50.1). The gated LP PC line (9.50.1) prevents "forward" from coming up for the duration of the 10- $\mu$ s pulse, thus preventing a timing condition by making sure that "go" is dropped before "forward" becomes active. If "forward" were allowed to come up and mix with a short pulse of "go," the load point status trigger could be immediately reset by "reset LP" as generated on circuits shown on Systems 9.50.2.

#### **Circuit Description—High Speed (Figures 80, 83, 84, 93)**

At the beginning of the operation a test was made (Systems 9.30.1) to determine if a high-speed rewind was necessary. The high-speed rewind sensing circuit, covered in another section, essentially removes the reset condition from the high-speed rewind status trigger so that it can be set by "initiate rewind." The trigger, turned on, blocks activation of "R7 motor reverse," thus

preventing the pick of R7 and acting as a control over subsequent circuit operations.

Before the operation can proceed, a further test must be made to see if tape must first be unloaded or if it is already out of the columns and ready for an immediate high-speed rewind. Because tape is in a high-speed area and loaded, we must stop the capstan motors, raise the head out of the way, and take tape out of the columns before the rewind motor can be energized. Not having "R7 motor reverse" blocks the "R3 capstan motors" circuit (9.40.1), stops the capstan motors, and causes both capstans to be spring-returned out of the path of tape.

Once the capstans are out of the way, the head and tape take-up motors can be energized (9.35.1). Note that both triggers are held reset whenever the capstans are not in a fully retracted position. The head motor trigger is turned on by the inactive condition of "R7 motor reverse," and will not be reset again until the head-up microswitch is mechanically closed. All resets are now removed from the tape take-up motor trigger; therefore it is turned on by "reel stopped." The motor will continue to run until relay 6 is dropped, at which point the trigger is reset by "unload gate," signifying that tape is not in either column. Note that there is no interlocking of the head and tape take-up motors; they start simultaneously and are stopped by their own unique conditions. Because relay 7 (motor reverse) was not picked during this phase of the operation, both motors run in the proper direction.

At this point, "R5 high-speed rewind motor" (9.40.1) is activated by the following logical conditions: not R7 motor reverse, tape not in left and right columns, head up, load-rewind, and not unload status. Relay 5 (high-speed rewind motor, 9.45.1) turns on the high-speed rewind interlock trigger and removes all electrical brake from both reels.

The high-speed rewind operation continues until the lamp and photocell combination recognizes less than 1/2 inch of tape on the machine reel (9.30.1). Light striking the cell in the finger guard resets the high-speed rewind status trigger, and in turn activates "R7 motor reverse," picks the motor reverse relay, R7, and deactivates "R5 high-speed rewind motor" (9.40.1).

Deactivating "R5 high-speed rewind motor" immediately applies partial brake to the machine reel (9.45.1). During high-speed rewind, the eddy current sensing device causes the mercury switch circuit to open and remain open until partial right brake slows the reels to a stop. At this time, the counterbalance activates "reel stopped" and immediately turns on the tape take-up motor trigger (9.35.1). From this point, the completion of the operation is explained in the low-speed section.

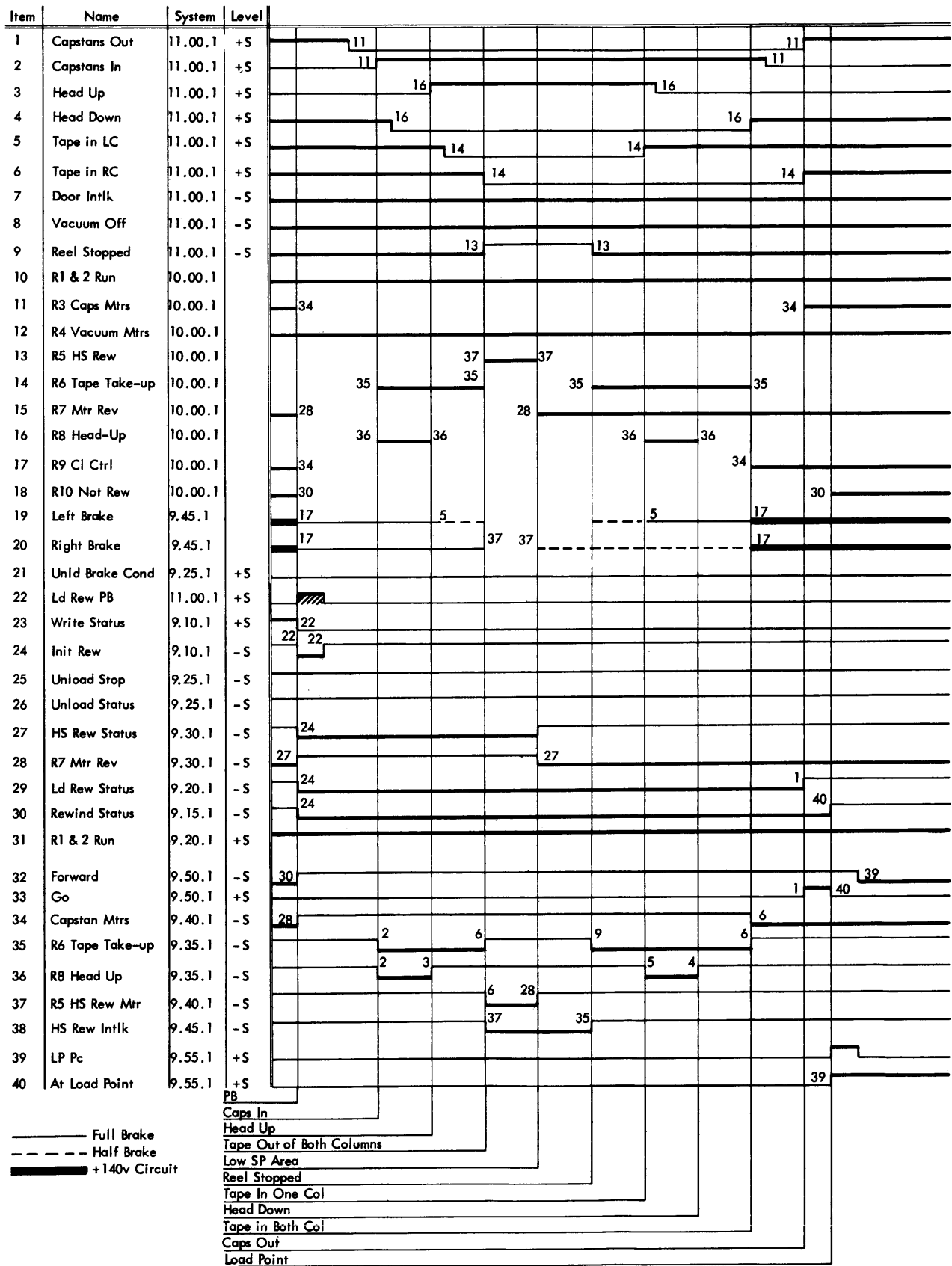

Figure 83. Load-Rewind Sequence Chart (High Speed)

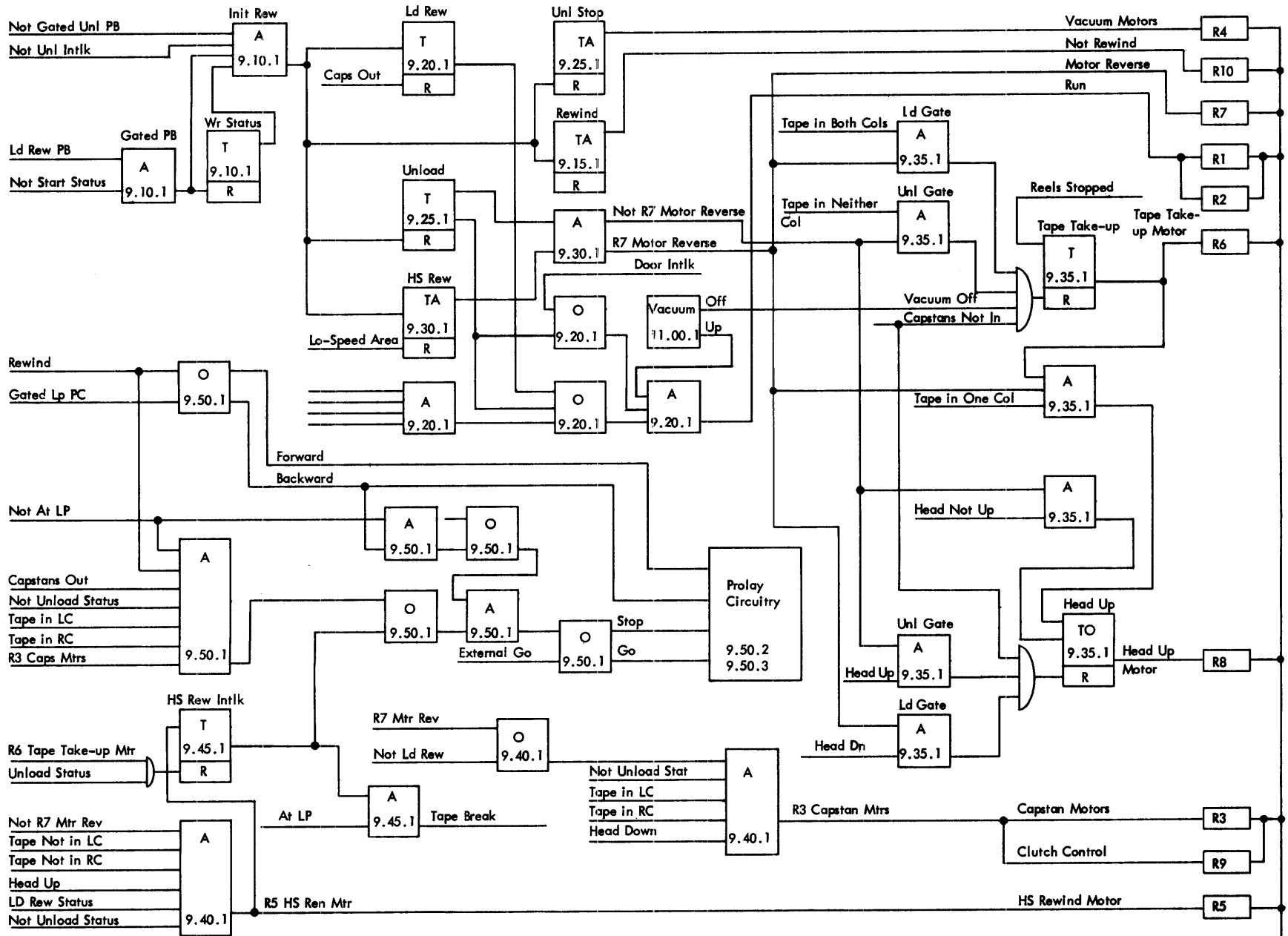

Figure 84. Load-Rewind Condensed Logic (High Speed)

Note that the high-speed rewind interlock trigger (9.45.1) monitors only the high-speed part of the operation, and is reset as soon as the tape take-up motor circuit is energized. "High-speed interlock," mixing with "tape in either column," applies partial left brake as an anti-spill measure.

### Unload

The normal unload operation raises the head mechanism and removes tape from the columns, so that the operator can remove the file reel. No rewinding or search for load point is involved. This is a manual operation, initiated by depressing the unload key; it requires essentially that the machine be out of ready status.

#### Circuit Description (Figures 85, 86, 87, 93)

The unload operation is initiated by the unload key (11.00.1). The key pulse, mixing with machine not in start status and machine not in the process of high-speed rewinding (9.25.1), produces a "gated unload PB" pulse. This generates a reset (9.20.1).

Any manual operation which requires tape to be moved at the head area must force the machine out of write status to prevent destroying or erasing valuable information. The reset line accomplishes this (9.10.1), at the same time turning on the unload trigger (9.25.1).

"Unload status" deactivates "R7 motor reverse" (9.30.1) and blocks the capstan motors circuit (9.40.1), thus assuring that the capstans are fully retracted before unloading can proceed. When relay 3 (capstan motors) drops, the capstan motors coast to a stop, allowing the shafts to retract. At the same time, relay 9 (clutch control) drops, placing the stop clutches under 48-volt NOR circuit control.

Closing the capstans-in microswitches removes the reset controlling both the head and tape take-up motors (9.35.1). The head motor trigger is turned on by the inactive condition of "R7 motor reverse" and is finally reset, again, by mechanical transfer of the head-up microswitch.

At the same time that the head motor trigger is turned on, the tape take-up motor is energized by "reel stopped" (9.35.1). The motor continues to run until tape has been removed from both columns, at which time "unload gate" will apply a reset to the trigger and cause relay 6 to drop. There is no need to interlock these two motor circuits at this point; both motors start simultaneously but are stopped by their own controlling conditions.

The unload-stop trigger (9.25.1) is turned on at the completion of the unload operation by the following

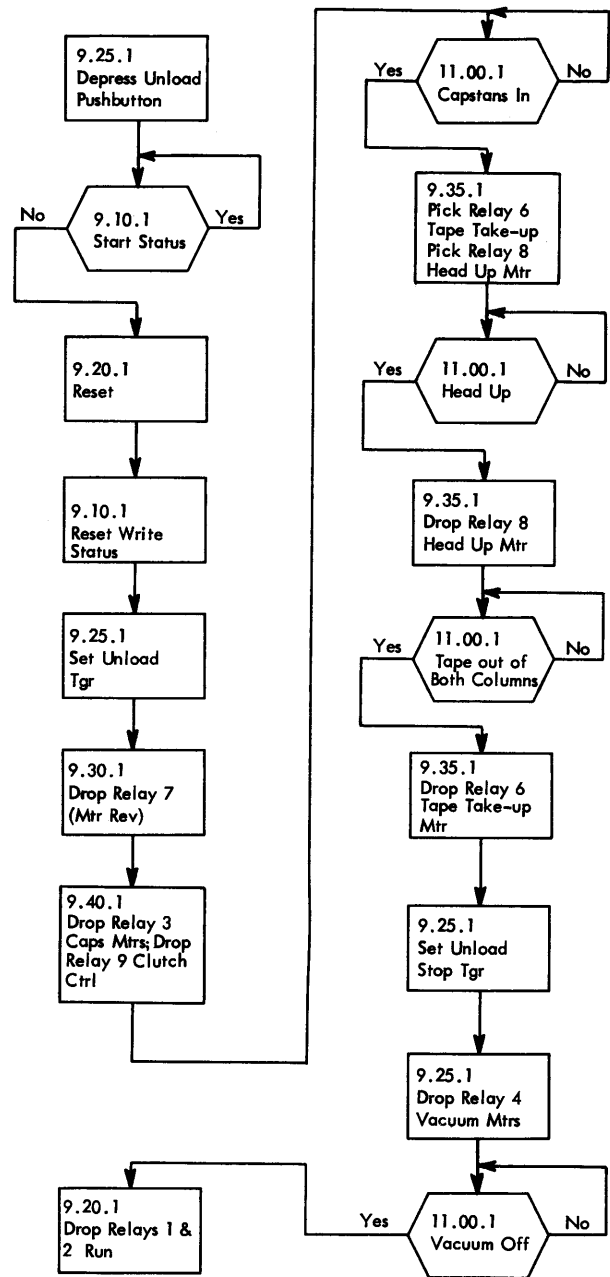

Figure 85. Unload Flow Chart

conditions: capstans are in and not running, tape is out of the left and right columns, the head is up, and this is an unload operation. The turning on of the trigger drops relay 4 and stops the vacuum motors. As vacuum falls, the bellows switch closes, dropping the R1 and R2 run relays, and opening the 3-phase circuit to the forward and reverse clutch drive motors (16.00.00).

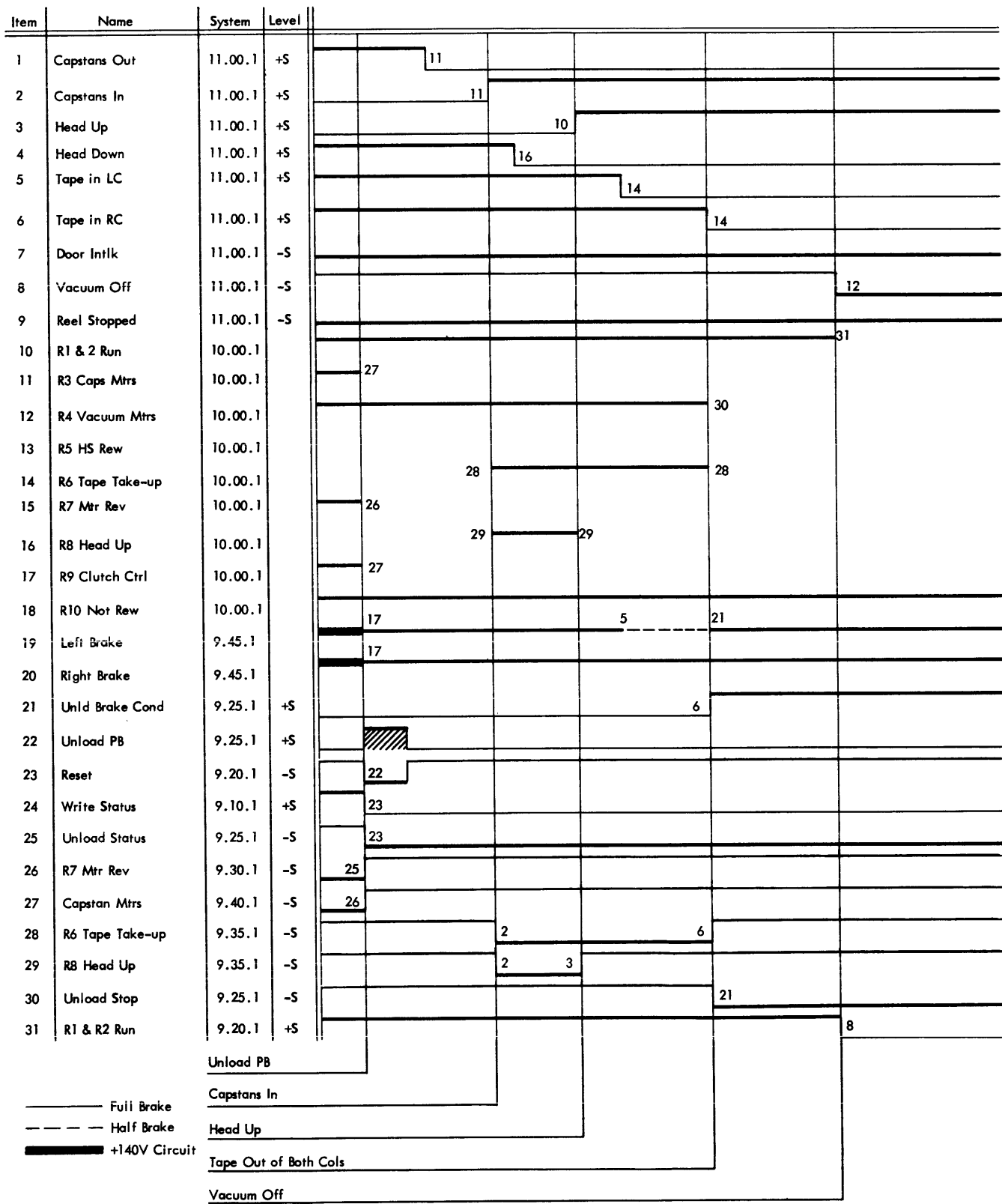

Figure 86. Unload Sequence Chart



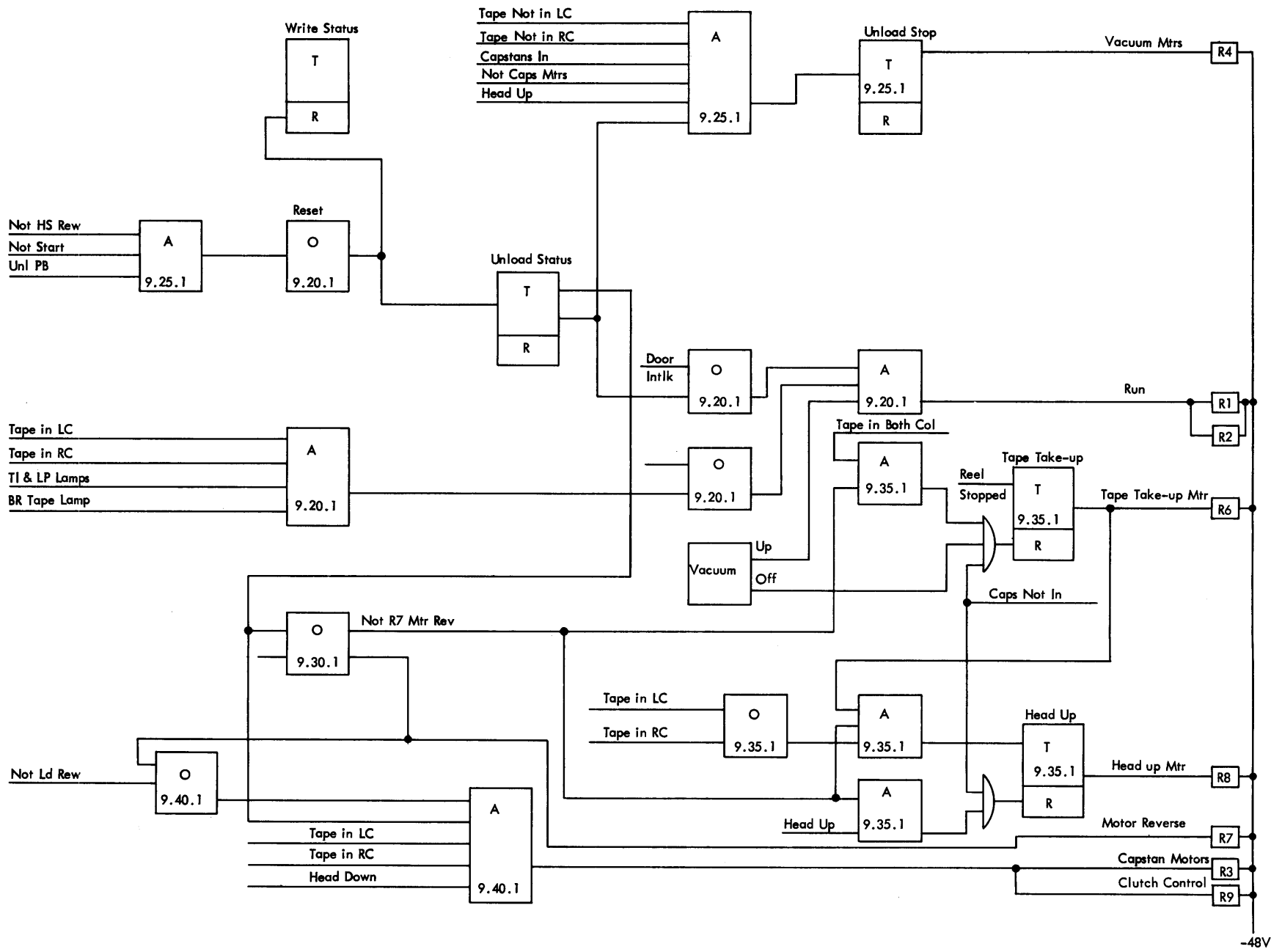

Figure 87. Unload Condensed Logic

### Special Considerations

The unload key involves functions in addition to those explained in the previous paragraphs.

Unload will take priority during a simultaneous depression of the unload and load-rewind keys by blocking the initiate rewind circuit (9.10.1). "Gated unload PB" suspends operation of both the head and tape take-up motors, until the key is released (9.35.1). If tape should spill or load improperly into the vacuum columns, the unload key can stop the operation until corrected by the operator. Releasing the key allows the operation to continue.

This same circuit (9.35.1) will also reduce burning of the relay 7 (motor reverse) points if an unload operation is called for during loading. Both relays 6 (tape take-up motor) and 8 (head motor) remove power from their corresponding motors during the time that relay 7 (motor reverse) is transferring. When relay 7 has dropped and the key is released, relays 6 and 8 are again picked.

The unload key in conjunction with the reset key can be used to immediately stop a high-speed rewind. The reset key removes the high-speed rewind status by resetting the trigger (9.30.1) and in turn dropping relay 5 (9.40.1). "R5 high-speed rewind motor," upon becoming inactive, allows a "gated unload PB" pulse to be generated (9.25.1). This produces a reset (9.20.1) which in turn turns on the unload trigger. Finally "unload status" produces "unload brake condition" and turns on the unload-stop trigger. "Unload brake condition" (9.45.1) immediately applies both right and left full electrical brake.

### Rewind

The rewind operation is usually initiated by a programmed instruction in the CPU, and is designed to return the tape to load point. To save time, more than 1/2 inch of tape on the right reel forces the machine into a high-speed operation. As in any backward tape movement, file protection is brought into play, inhibiting writing and erasing. A rewind instruction presented to a tape already at load point will produce no logical operation.

#### Circuit Description—Low Speed (Figures 82, 88, 89, 93)

The rewind signal pulse (8.20.1) can result from a CPU instruction during on-line operation (8.00.1) or from an end-of-tape recognition during an off-line cycling operation at the CE panel (13.00.1). Either source requires that the tape unit be "select and ready" (9.10.1). If "select and ready" is available, the write status trigger will be reset (9.10.1) so that all write head and erase head circuitry will be blocked (7.10.1).

The deactivation of "write status" generates "initiate rewind" (9.10.1) and turns on the rewind trigger (9.15.1). "Rewind status" then brings up "backward" (drops "forward," 9.50.1) and drops relay 11 (10.00.1). Relay 11 opens the write head and erase head circuits to offer further file protection during the rewind operation.

The low-speed area condition prevents "initiate rewind" from setting the high-speed rewind interlock trigger. Therefore relay 7 remains picked and "R7 motor reverse" remains active (9.30.1). "R3 capstan motors" remains active (9.40.1), and allows "go" (9.50.1) to start moving tape backward. "Go" is finally conditioned by: tape in both columns, rewind status, capstans are out and turning, and not unload status.

The prolay driving circuit now drives tape backward in search of load point. The LP photocell (9.55.1) causes a 10μs pulse to be generated when the reflective spot passes the head area, turning on the load point trigger. "At load point" then resets the rewind

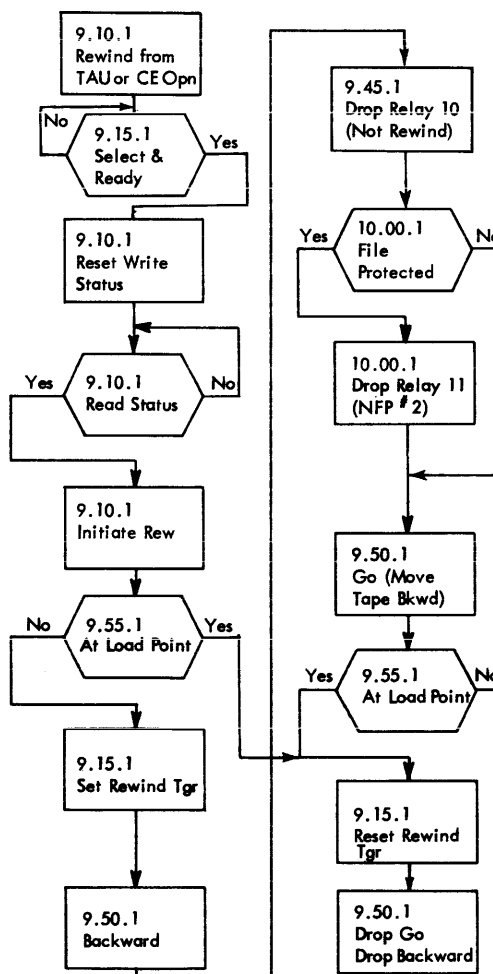

Figure 88. Rewind Flow Chart (Low Speed)

trigger (9.15.1) and drops "go" (9.50.1). The reset rewind trigger tries to bring up "forward" (9.50.1), but "gated LP photocell" holds it inactive for the duration of the 10 $\mu$ s pulse. The operation is completed with return of the unit to a forward stop condition.

The tape could initially be at load point when the rewind instruction is given. In this case, write status

is reset and "initiate rewind" is generated (9.10.1). The rewind trigger, however, is held reset by the "at load point" condition. No tape movement is involved; the net effect is the possibility of a change from write to read status.

A rewind operation occurring in a high-speed area is similar to that discussed under load-rewind.

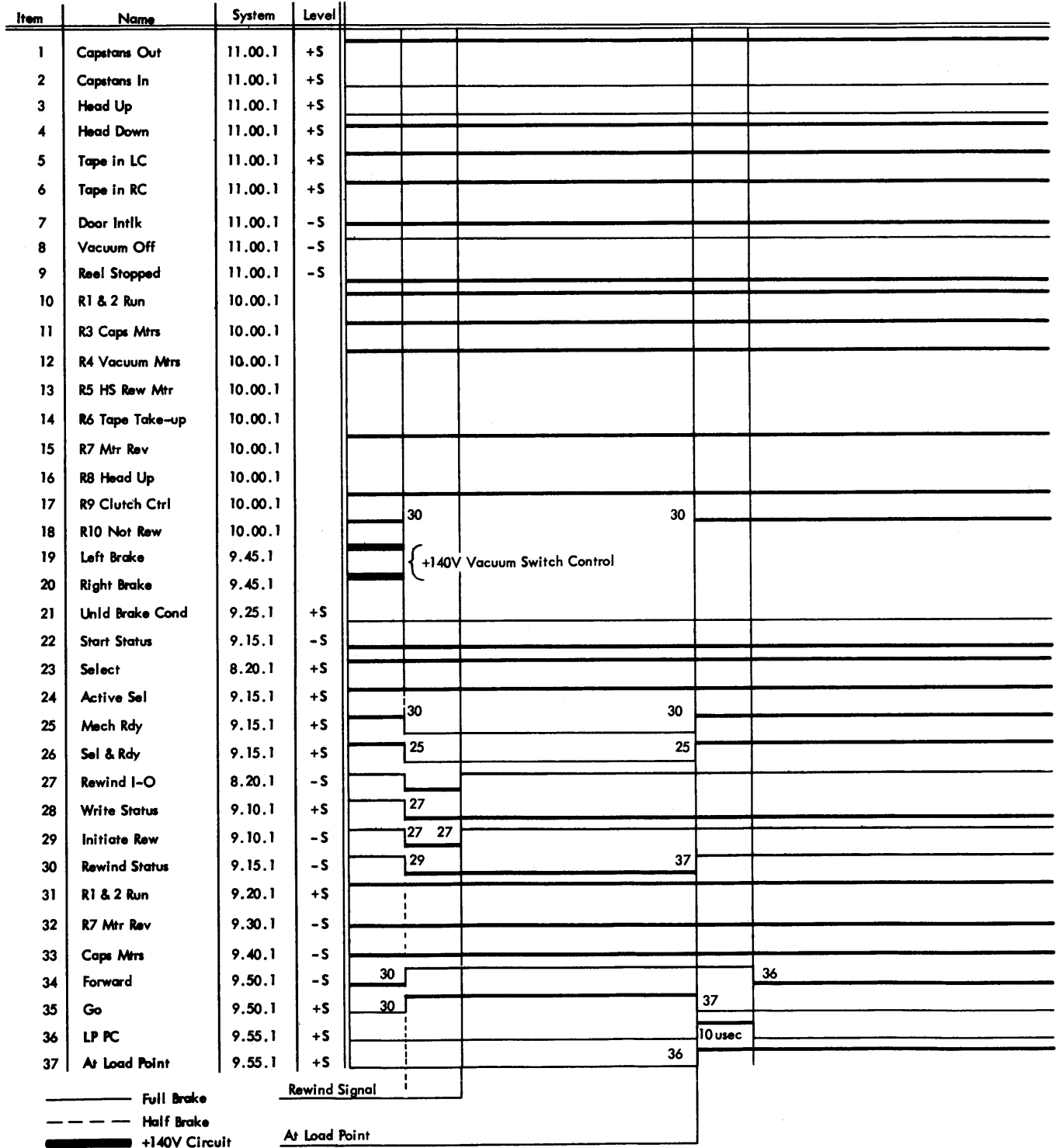

Figure 89. Rewind Sequence Chart (Low Speed)

## Rewind and Unload

This operation combines the functions of both the rewind and the unload operations.

A single program instruction can rewind and automatically unload the tape, ready for removal of the file reel by the operator. Unloading is a very convenient way to remove a newly created tape from the system, and eliminate the possibility of inadvertently reusing it as a work tape and destroying its information.

### Circuit Description—Low Speed (Figures 90, 91, 92, 93)

A rewind and unload operation originates in external program control. The signal from the controlling unit (Systems 8.20.1) mixes with "active select" (9.10.1) to turn on the rewind and unload trigger. (The use of "active select," at this point, has no logical significance beyond that of being selected.) This condition, mixing

again with "select and ready," resets the write status trigger and allows generation of "initiate rewind."

From this point the operation is the same as the normal rewinds described in earlier sections. Recognizing load point completes the first phase, rewinding. The rewind-unload trigger, turned on at the beginning of the operation, now takes over and initiates the final phase, unloading. "Unload status" (9.25.1) is set by "rewind and unload status" mixing with "at load point" and "not R5 high-speed rewind motor." "Unload status" deactivates "R7 motor reverse" (9.30.1), starting the unloading operation. The sequence of events is the same as that covered in the section on unloading.

The normal reset to the rewind trigger (9.15.1) is not used if the rewind and unload instruction is given at load point. In this case, the reset occurs, not upon "at load point," but later when "unload status" is set; thus the necessary "select and rewind" signal can be generated and returned to the controlling unit for reset purposes.

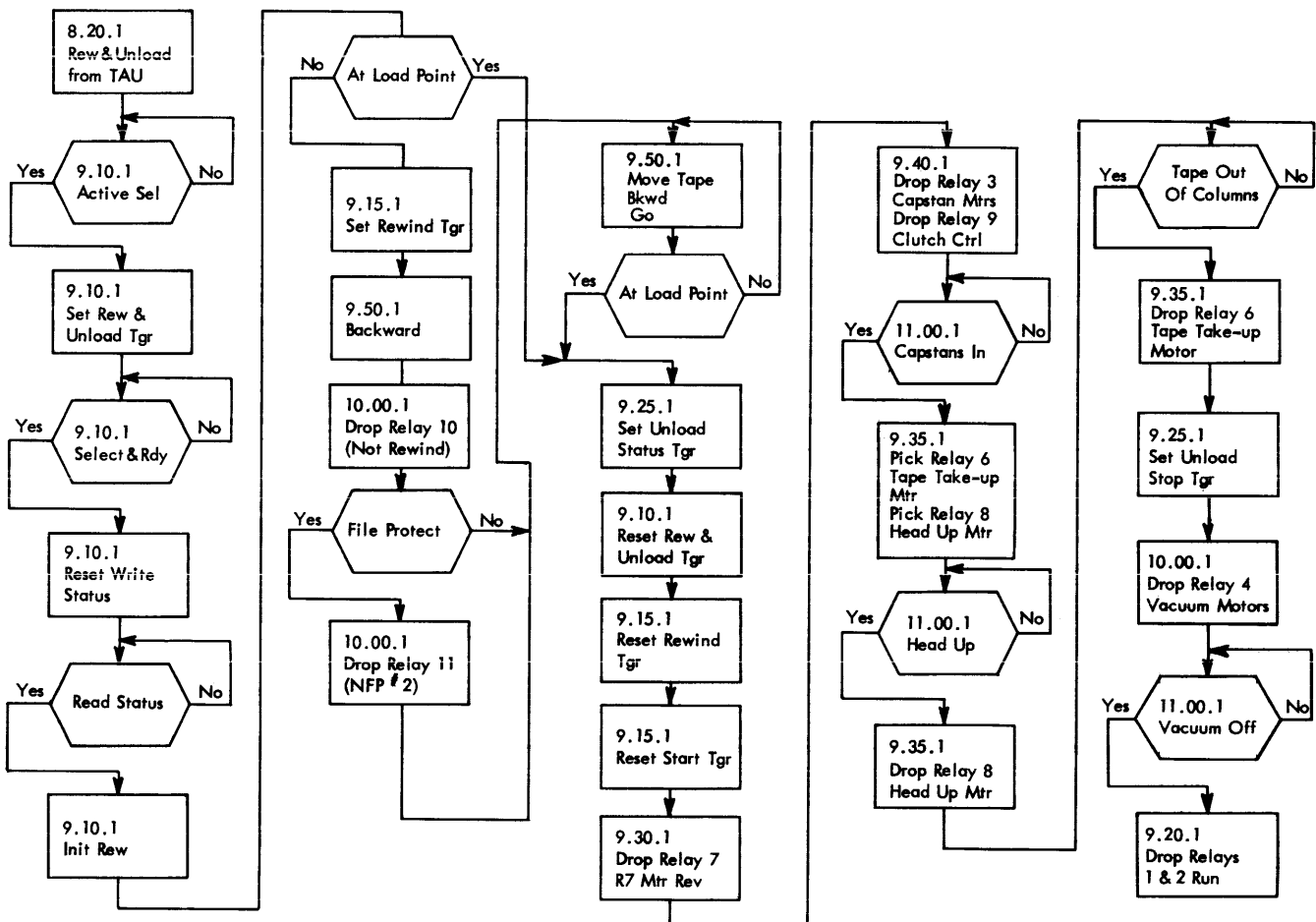

Figure 90. Rewind and Unload Flow Chart (Low Speed)

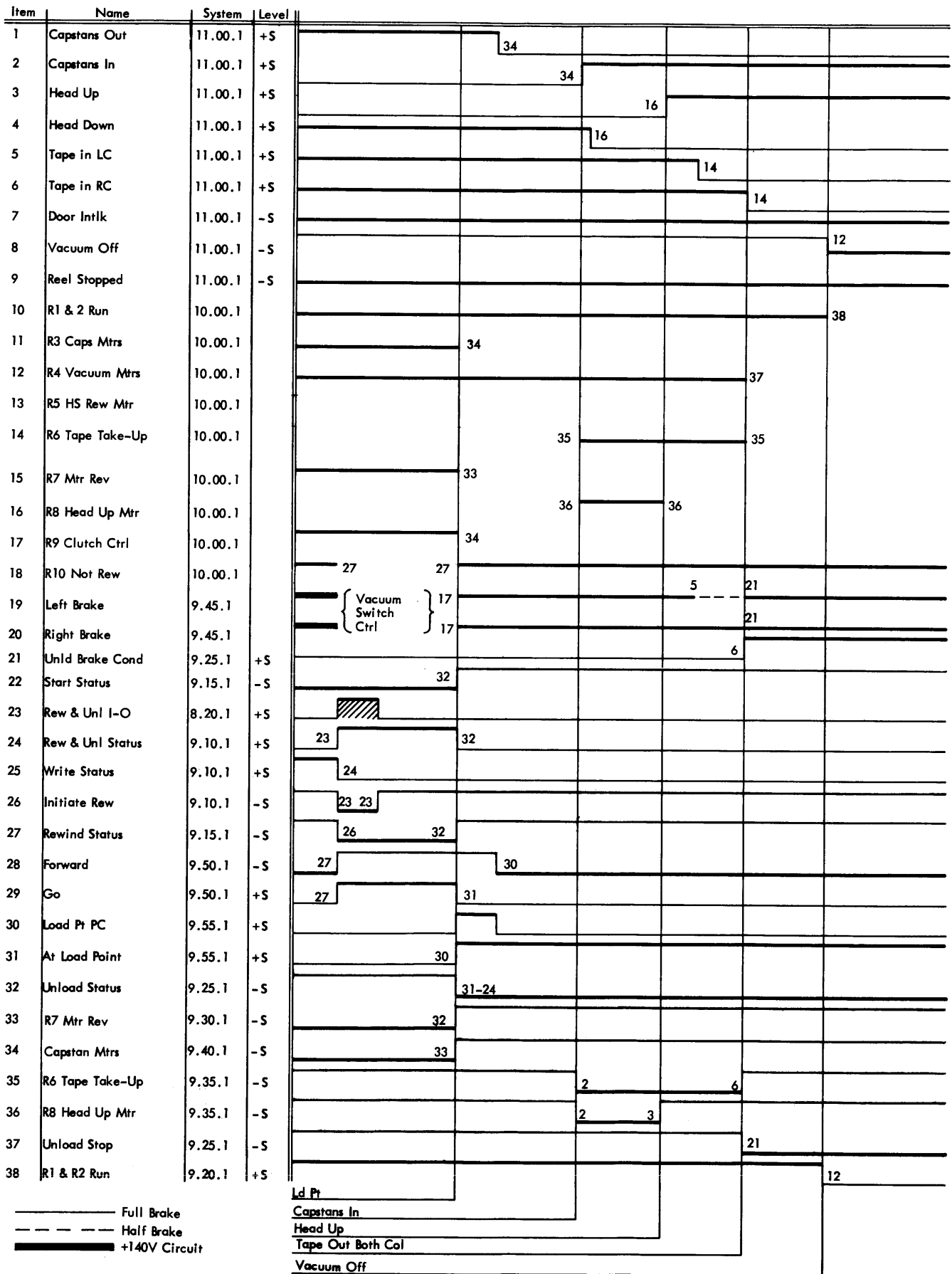

Figure 91. Rewind and Unload Sequence Chart (Low Speed)



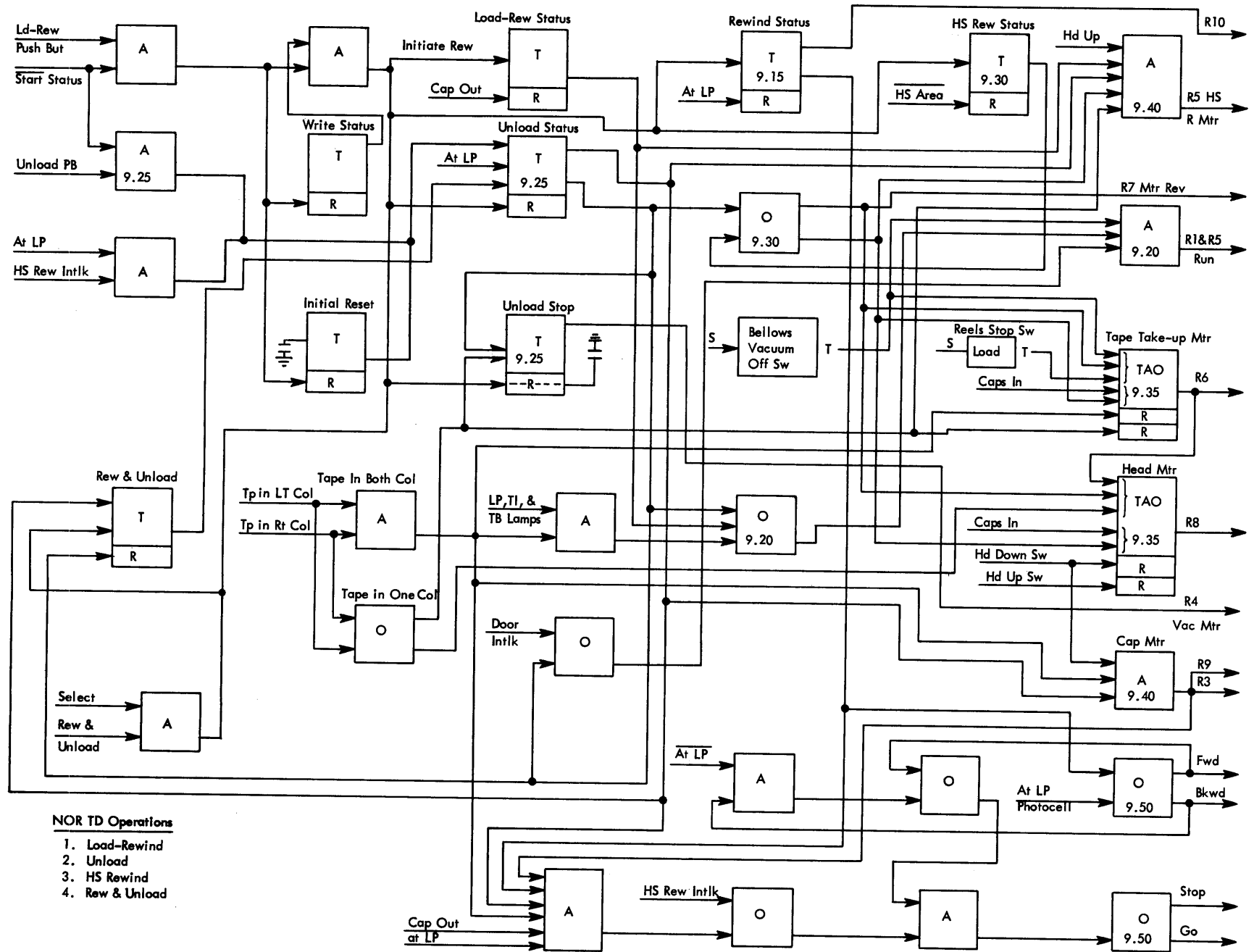

Figure 93. Over-all Condensed Logic

## Lines Entering and Leaving the Tape Unit

### Input Lines (Systems 8.00.1)

*GO* originates in the external control source and controls the status of the prolays.

*Backward* is AND'ed with "select and ready" to produce "reverse," which controls the status of the prolays. The backward line is also AND'ed with "not at load point" to prevent backspacing when the tape unit is at load point. The backward line originates in the external control.

*Select Line (8.30.1)* determines which tape unit is selected. The ten select lines are routed from the external control.

*Start Rewind* originates in the external control to start a rewind operation.

*Set High Density* originates in the external control to set the status of selected tape unit for high density writing.

*Set Low Density* sets the status of the tape unit density circuit to indicate that writing is to occur at low density.

*Turn Off TI* originates in the external control and is used to turn off the tape indicator trigger in the selected tape unit.

*Turn On TI* originates in the external control and turns on the  $\pi$  trigger in the tape unit.

*Rewind and Unload* originates in the external control and initiates a rewind operation followed immediately by an unload operation.

*Set Write Status* is an input from the external control to turn on the write status trigger.

*Write Pulse* is a line, originating in the external control, over which timed pulses are sent to flip the write triggers.

*Write Bus* consists of seven lines. Information is sent over it to the tape unit to condition the write triggers.

*Write Check Character* originates in the external control to reset the write triggers after a record is written. Resetting the write triggers causes a longitudinal check character to be written on tape.

*Set Read* is an input from the external control to set the write status trigger off. This action puts the tape unit in read status.

### Output Lines (Systems 8.10.1)

*Select and at Load Point* is generated in the tape unit and routed to the external control to indicate that the selected tape unit is at load point.

*Select and Ready* is routed to the external control source to indicate that the selected tape unit is mechanically and electrically ready.

*Select and Not at Load Point* is routed from the tape unit to the external control to indicate when tape is not at load point.

*Select and Rewind* is an output of the tape unit and indicates to the external control that the selected tape unit is rewinding.

*High-Low Density* is the output of the density circuit in the tape unit. It is routed to the external control to indicate the density at which writing is to occur (low, 200 characters per inch; high, 556 characters per inch).

*Sel and TI Off* is a response line from the tape unit to the external control to indicate status of the  $\pi$  trigger.

*Sel and TI On* is a response line from the tape unit indicating the status of the tape indicator trigger.

*Sel Ready and Write* originates in the tape unit to indicate to the external control that the selected tape unit is ready and in write status.

*Sel Ready and Read* is a response line from the tape unit indicating to the external control that the selected tape unit is mechanically and electrically ready and in read status.

*Read Bus (Systems 7.00.0)* consists of seven lines over which information is transmitted to the external control during a read operation.

*Write Echo Pulse* is a line from the tape unit to the external control. The echo outputs of the seven head drivers are combined in an OR circuit and sent to the external control on the write echo pulse line to indicate that a character has been written.

### Input-Output Line Specifications

Minimum voltage levels for N-type lines are: up level +0.4 volt, down level -0.4 volt. Minimum voltage levels for P-type lines: up level -5.6 volt, down level -6.4 volt.

#### Input

Rise and fall times for the following lines shall not exceed 1  $\mu$ s. Pulse width is not specified.

Select Lines (+P)

Backward (-N)

GO (+P)



The following lines require a minimum pulse width of 1  $\mu$ s:

- Set Read Status (+P)
- Set Write Status (-N)
- Turn On Tape Indicator (-N)
- Turn Off Tape Indicator (+P)
- Write Pulse (-N)

The write buses must be conditioned at least 5  $\mu$ s before arrival of the write pulse.

Lines requiring a minimum pulse width of 10 ms are:

- Start Rewind (-N)
- Rewind and Unload (+P)
- Set High Density (-N)

## **Output**

The following lines shall not have a rise or fall time exceeding 1  $\mu$ s:

- Select and Ready (+P)
- Select and Tape Indicate Off (-N)
- Select and Tape Indicate On (-N)
- Select and At Load Point (+P)
- Select and Not At Load Point (+P)
- Select Ready and Read (+P)
- Select Ready and Write (+P)
- Select and Rewind (-N)

The write echo pulse requires a minimum pulse width of 1  $\mu$ s.

## Service Aids

### General Troubleshooting Hints

The possible causes for the troubles listed in the following sections were uncovered through experience on similar machines and through extensive tests on the equipment.

#### Signal Drop-Out

This term indicates that the voltage amplitude of a signal was decreased to such a value that it could not be correctly detected as a 1-bit. Two main causes for this are:

1. An irregularity on the tape surface may lift the tape away from the read-write head when a one is being written. This reduces the resulting voltage amplitude obtained when reading. Surface imperfections can be caused by magnetic oxide clumps or backing particles.
2. The lack of magnetic coating, caused by wear at the point where a pulse is supposed to be recorded, is another source of signal drop-out.

#### DROP-OUT FAILURES

Dirt, whether on the tape or any of the surfaces on which the tape travels, is one of the major causes of errors in a tape system. The slightest lifting of the tape from the reading head, when reading a one, has a marked effect on the signal output waveform and amplitude, resulting in a signal drop-out.

Another source of signal drop-out is trenching (a groove or trench in the read-write head). This groove is the result of extended operation, where the tape literally saws a trench in the head. Trenching is visible and is also indicated by excessive skew and dropped bits (especially the 1-bit and C-bit tracks).

Intermittent reading failures have been caused by foreign material on the tape. The following method is suggested for locating foreign material.

When the machine stops, indicating an error, mark the tape where it crosses both split idlers. Unload the tape unit and inspect the tape between the marks on the tape. The error will have occurred in this area.

When excessive skew or flutter seems to be a problem, check the split idlers for binds. A bind at this point can give the indication of excessive skew.

#### Noise Pulses (Pickup)

The difference between signal drop-outs and noise is that drop-outs are usually caused by the magnitude of the distance between tape and head or the magnitude

of oxide discontinuity. Noise is generally a function of the rate of change of the movement between tape and head or the rate of change of the discontinuity. Similarly, noise errors arise from discontinuities in the oxide. Surface irregularities also contribute to noise.

Other sources of noise or signal drop-outs are metal chips which may change the reluctance of the magnetic path of the flux. Oxide clumps push the tape away from the head and also change the magnetic reluctance of the flux path.

To eliminate any errors originating from the above causes, inspect the tape drive and associated areas for accumulations of dirt, oxide clumps, or foreign material.

#### Noise and Ground Loops

Low signal levels and fast switching time of transistor circuits require the noise level to be very low on all ground wires and service voltage wires. It is important that there be no more than the one central grounding point on the back of the preamplifier box, right side. Two other frame ground points on the left side of the preamplifier box are for the preamplifier itself. Some of the read bus shields may also be tied to the left side.

To check for ground loops, disconnect all common ground points on the preamplifier and check continuity between the frame and any ground wire other than the preamplifier box. Be sure to check the ground buses on the transistor logic (back) gate. **NOTE:** Remove the signal cable. Use the  $\times 100$  scale. There should be no measurable deflection (infinite resistance). Also check the tape unit signal cables for shorts to ground.

Each shield is separated from the others throughout the signal cable, the cable shoe, and the receptacle in the tape unit. They are tied together at one point *only*, the top back of the preamplifier box. They are also tied to frame ground at this point.

#### False Noise Records

False noise records can occur because of improper filtering of a vacuum column switch, usually caused by broken leads on the filter assembly. To check for this, place the tape unit in read status with the capstan motors disconnected. Manually position the tape so that it oscillates about one of the sensing ports.

Observe the read bus for transient noise pulses, at the same time lightly vibrating the vacuum switch cover. Check all ports in this manner.

Check for faulty bypass capacitors or diodes.

#### INTER-RECORD GAP NOISE

Before backspacing or rewinding while in write status, all tape systems automatically write forward first. This erases tape ahead of the last good record so that the next inter-record gap is clean when repositioning to this point for the next write operation.

Use caution if a tape unit is manually unloaded at this last record area (in write status). After reloading tape and reading forward to this same last record, remember that the tape ahead of this last good record has not been erased. Up to  $\frac{1}{8}$  inch of old record information may be left in what will be the next inter-record gap when writing is resumed.

This condition occurs because GO is dropped later in read status than in write status. Therefore, when repositioning the tape in read status, the write head will be positioned well beyond the write status stopping point of tape. The difference in stopping points is about  $\frac{1}{10}$  to  $\frac{1}{8}$  inch.

Operators should be warned of this possibility of leaving bits in the inter-record gap when manually unloading tape in write status.

#### INTERMITTENT READ BUS NOISE

Magnetic clutch brush wires should be dressed away from clutch pulleys. If the wires are allowed to drag on the pulleys, the insulation will wear through. This condition can be a source of intermittent read noise.

#### Load-Unload-Rewind Failures

##### LOAD FAILURES

A failure on load-rewind operation may be corrected by adjusting the bellows switch.

A loose manifold on one drive may cause tape to spill in the column.

A loose connection on the tape break lamp causes loading failures.

In cases where tape billows out upon loading into columns after high-speed rewind, check the rewind idlers and split idlers. The idlers must be absolutely free-running with no binds. End play of .001 inch is allowable on the rewind idlers.

Other causes of load failures are:

Load point photocell has low dark resistance.

Flapper valves are binding.

Friction clutch compression spring causes head to bind.

Vacuum column switch transfer strap binds or is cracked.

Head-down microswitch is loose.

Magnetic clutch brush blocks are loose.

Magnetic clutches are leaking powder.

Load point lamp is burned out.

Head cover is binding.

Tape reel is not seated properly.

Vacuum leaks.

Tape chips are in column.

##### UNLOAD FAILURES

Tape too tight at the end of an unload can be caused by the one-half brake adjustment.

A bellows switch that is out of adjustment causes tape to break at the end of an unload operation.

Other causes of unload failures are:

Binding flapper valves.

Binding capstan shafts

Capstan sensing switches out of adjustment.

Magnetic clutches leaking powder.

Weak tension on clutch commutator brushes.

Dirty commutator rings.

##### REWIND FAILURES

When the tape unit goes into a high-speed rewind but the high-speed rewind motor fails to start because of excessive drag on the reels, check the clutch demagnetizing circuit and check for binds in clutch shafts (no power on machine).

Tape may be raised too slowly in the right column because of a worn brush to the right-reel-up clutch.

An adjustment of one-half brake may be required to prevent tape breakage on high-speed rewind.

Wrinkled tape can be caused by a jerky stop after a high-speed rewind, just before loading the tape to go into the low-speed area.

#### Tape Contamination

##### REEL HUB KNOB

Metallic particles are sometimes found inside the hub. A tenacious lubricant such as IBM 24 should be applied to alleviate this condition.

##### REWIND IDLERS

Loose particles may be found, resulting from the pressing of the idler on the shaft. These particles should be removed with a penknife or else they may be thrown into the system.

#### Tape Breakage

##### HIGH-SPEED AREA

Brake out of adjustment.

High-speed rewind idler binding or too much end play.

##### HEAD AREA

Binding head covers.

Head up and down microswitches loose.

Tape cleaner bent and out of adjustment.

#### SHORTED WRITE HEAD CABLE

If a short to ground occurs anywhere in the write cable, the write head may be burned out. Therefore, if a burned-out head is found, the write cable should be thoroughly checked for shorts before mounting a new head. Also, the cable connector clamp should be screwed onto the connector tightly before the cable is clamped. A loose cable connector clamp can greatly aggravate a worn cable condition.

#### CAPSTANS

On capstan motors manufactured after September 1, 1960, and identified by suffixes LW, LX, LY, or LZ to the right of the five digit number on the name plate, the spring bushing may collapse and allow the capstan to extend too far forward, causing the following:

1. Contamination of the bearings or slowing of the motor because of the bushing particles. Permanent damage to the motor can result from excessive heat.
2. Possible damage to the capstan-out sensing switch assembly.
3. Inoperative machine if the capstan-out switch transfers.

The fault condition can be identified by:

1. Persistent read-write errors caused by the decrease in motor speed.
2. Noise caused by the flywheel rubbing against the switch magnet or rear oil cup.
3. Measuring the distance between the vacuum column door and the capstan while the motor is running. The distance should be not less than  $\frac{1}{2}$  inch. If trouble is experienced, remove the motor and loosen the housing screws, sliding the front bell housing forward. Do not remove the taper pins. Use a small mirror and flashlight to inspect the bushings.

In addition to the above fault, check for loose or out-of-adjustment microswitches.

#### MAGNETIC CLUTCHES

- Brush blocks loose.
- Dirty commutator rings.
- Powder leaking, resulting in binds.

#### COLUMNS

- Vacuum leaks.
- Tape chips in column.
- Bellows switch out of adjustment.
- Vacuum column switch transfer strap broken.
- Flapper valves binding.
- Column tops with rough edges.

#### IMPROPER TAPE HANDLING (LOADING)

If the tape unit door is opened just after the tape has risen from the columns, causing the tape to be stopped

by the capstans instead of coming to a normal stop, tape may break. Tape breakage has also been traced to poor alignment of the rewind motor. Excessive vibration within the tape unit frame during high-speed rewind makes it possible for the capstans-in switches to drop out of the circuit and cause tape breakage.

#### TAPE DUMPING CAUSED BY BRAKE CLUTCH

Clutch powder deterioration and leakage affect clutch response and cause tape dumping in the columns. Study of the functions of the three clutches shows that the brake clutches cause tape dumping more often than a faulty up clutch.

*Requirements of Up Clutch:* The up clutch accelerates the reel from a stopped position to capstan speed before the tape loop can bottom in the column. The up clutch is energized when the tape loop goes below the lower vacuum port.

*Requirements of Down Clutch:* The down clutch accelerates the reel from a stopped position to capstan speed before the tape is pulled out of the column. The down clutch is energized when the tape loop goes above the upper vacuum port.

*Requirements of Brake:* The brake must respond to a condition worse than that encountered by either the up clutch or the down clutch. This condition presents itself when the direction of the tape over the head is reversed. Consider the condition where tape is told to go backward just as the tape loop passes the upper port while traveling down in the left column. At this time tape is being dumped in the column by the reel at approximately 280 inches per second (considering a full reel of tape) and by the capstan at 112.5 inches per second. The brake *must stop the reel* before the loop reaches the lower port. The up clutch cannot be relied upon to prevent the tape from dumping if the brake has *not* stopped the reel before the loop reaches the lower vacuum port. It is most important here to distinguish between *reel* motion and *tape* motion in the column. To function properly, the up clutch must depend on the *reel's* being *stopped* by the time tape passes the lower port. Therefore, the tape going below the lower port during a tape reversal is usually due to a poor brake. A poor brake also causes tape to pull out of the column if the down clutch and the column upper port are considered.

A variation of the tape reversal dumping occurs in a loading operation. An additional factor that can give the appearance of a faulty brake is a jitter brake with insufficient tension. When the tape in the column motor is de-energized, the momentum of the clutch housings continues to load tape into the column for a time, although the brake clutch has stopped *reel* motion with *respect to the brake housing*. If the *reel*

is still loading tape into the column as tape passes the lower port, the up clutch cannot reliably overcome this added motion. When these conditions occur, the tension on the jitter brake should be increased to ensure that the brake housings and gear train are stopped before tape reaches the lower port.

*Summary:* If tape dumps:

1. While processing in one direction—check the appropriate up clutch.
2. While changing direction during processing—check the appropriate brake clutch.
3. While loading—check jitter brake tension and possibly the brake clutch.

Other causes of tape dumping are faulty vacuum switch bypass capacitors or diodes or dirty or slow-acting vacuum switch contacts (insufficient spring tension).

## Magnetic Clutches

### CAUSES OF CLUTCH FAILURE

To check operation or to troubleshoot up or down clutch and associated relays and vacuum switches: load tape and stop immediately (to prevent dump if either clutch fails). Open the door and use the reel release key to place tape below the lower vacuum switch to test up clutch, or above the upper vacuum switch for down clutch. Unplug the reel drive motors. Hold the reel being tested and close the door interlock. Rotate the reel back and forth, being careful not to pass the vacuum switch opening (as this applies full brake). Watch the clutch brushes for arcing. Compare the feel of right and left clutches.

Dirty brushes or contact rings may work at one point and fail at another, so try rotating quickly one way, then the other, to check for momentary loss of grip by the clutch.

In troubleshooting a solid clutch failure, the reel may be held in position by a piece of cellulose acetate tape applied to the backplate while checking relay points and other sources, until clutch operation is restored.

### CLUTCH POWDER LEAKAGE

Clutch design permits the loss of a certain quantity of powder without impairing machine operation. Loss of magnetic powder from a clutch decreases the torque capacity and, thereby, the response time of the clutch. The result is that the tape loop in the vacuum column must travel further than normal. Because this abnormal condition is visual, it can be used as an approximate clutch performance indicator.

To insure standard observations, use this procedure: When the tape unit is running continuously in either

a forward or reverse direction, and with a full reel of tape first on the left reel and then on the right reel, the tape loop in the vacuum column will always be less than seven inches above the upper sensing hole. Any excursion farther than seven inches beyond the sensing holes is considered a failure. Before the clutch assembly is replaced, check the following items to determine their condition:

Vacuum column switch adjustments and resultant response.

Reel clutch contact brush assemblies for proper contact and tension.

If these items are satisfactory, the clutch assembly should be removed.

## Write Errors

Check tape.

Check ground connections on the read and write bus shielded cabling. These ground wires should stand a fair pull without coming loose.

Check to see that the read and write bus edge connectors are not shorting against adjacent pins.

Check the ground connections on the read and write head plug for tightness.

Check the read and write head plugs for tightness.

Compare checks can be made when the upper head H-shield does not seat properly during the load operation or creeps up during subsequent writing. This improper adjustment causes excessive feed-through. Two brass screws control lateral movement by squeezing the mounting block. The screws should be adjusted to allow free vertical movement with a minimum of lateral movement. After the shield is properly adjusted, apply Glyptal (or fingernail polish) so that the screws cannot loosen.

The upper head MuMetal shield sometimes prevents the head from seating properly; forming the shield eliminates this.

Position the upper head cover to provide clearance for the lower head cover when the head is down.

A defective delay line card can cause intermittent flipping of the write trigger. A small amount of ringing on the write pulse is normal, but an excessive amount will cause trouble. Scope the input to the delay lines and the inputs to the write trigger.

Make certain there is clearance between the prolay MuMetal cover and the lower head MuMetal cover. If they are touching the prolay, motion can be transferred to the head, resulting in skew.

Dirty contacts on R11A1 can cause low voltage to the center tap of the write head, resulting in low write current and low read signals.

## Miscellaneous Failures

### PHOTOSENSE HIGH-SPEED REWIND

The large halo around the light beam of the new style photosense high-speed rewind lamp may make adjustment difficult. By adjusting the lamp voltage to its minimum, the halo is eliminated and better focusing is possible.

### TAPE ADDRESS SELECTION

An unused tape unit should be in reset status.

### REWIND MOTOR COUPLING

Breakage of the rewind motor coupling is usually caused by misalignment of the rewind motor and clutch shaft.

### JACKSHAFT CLUTCH

The head up and/or down microswitch will not be operated at the proper time if the jackshaft clutch slips. This could cause the tape to dump or become stretched.

If this problem is suspected, clutch torque can be checked with a  $\times 10$  gram gage as follows:

1. Disconnect reel drive motors (safety).
2. Pull out door interlock switch.
3. Press load-rewind (no tape mounted).
4. Place the gram gage blade against the upper limit stop, measuring the tension required to prevent turning of the jackshaft.

A minimum reading of 300 grams is required for satisfactory clutch operation. If the clutch slips too easily, dip a tab card in cleaning fluid and pass it between clutch surfaces several times. If clutch torque is still insufficient, disassemble the clutch and stretch the spring about one and one-half times in length to increase tension.

## Transistors

### Identification and Substitution

TYPE	IBM P/N	N/P	NOTES
13	344892	PNP	1
25	318322	PNP	2
26	535441	PNP	—
28	518689	PNP	—
33	318324	PNP	3
42	369108	PNP	—
63	344891	NPN	4
75	318323	NPN	5
83	318325	NPN	6
94	369081	NPN	—

- NOTES: 1. Type 13 can be used for type 33 or 25.  
2. Type 25 cannot be used for type 33.  
3. Type 33 can be used for type 25.  
4. Type 63 can be used for type 83 or 75.  
5. Type 75 cannot be used for type 83.  
6. Type 83 can be used for type 75.

### Voltage Coding and Levels

#### Color Coding

- + 12 volts—Gray
- 12 volts—Purple
- + 6 volts—Orange
- 6 volts—Brown
- 7.5 volts—Blue
- 48 volts—White with orange tracer

#### Voltage Levels

N	+0.4v	— 0.4v
P	— 5.6v	— 6.4v
S	0.0v	— 12.0v
W	0.0v	— 48.0v

A 729 tape unit receives its input power (208-volt, 60-cycle, 3-phase) through connectors on the controlling unit. It may, however, be powered directly from wall outlets when not used with the system. Power into the tape unit is controlled by a power on-off switch on the back of the unit and through an interlock relay in the controlling unit to which the tape unit is attached. Three-phase power is used to run the motors, and the DC power supply input is drawn from phases 1 and 2. Figure 94 shows the power input configuration.

**Magnetic Tape Unit DC Supply**

The tape unit DC supply is a 60-cycle transistor-controlled power supply (Figure 96). The circuits are in the tape unit Systems 95.00.0; typical circuits are covered here. (Further information is in IBM Customer Engineering Manual, *60-Cycle SMS Power Supply*, Form 225-6478.) The input voltage is regulated by a constant voltage transformer. The output DC voltages are controlled for logic circuits and are merely filtered for other applications.

**Ferroregulator**

The ferroregulator is a closed, shell-type transformer which includes a magnetic shunt between the primary and secondary windings (Figure 95). Capacitor C1 (Figure 96) across one of the secondary windings

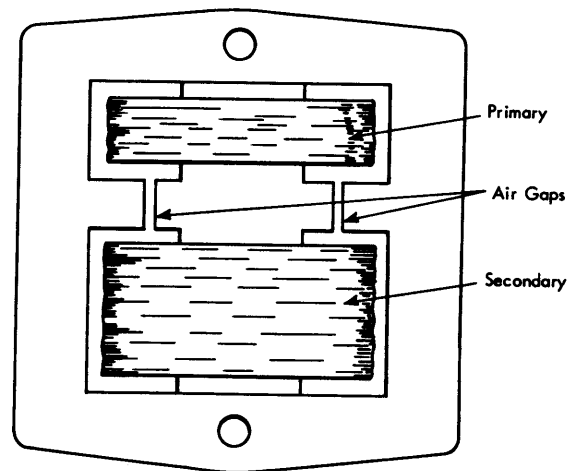

Figure 95. Ferroresonant Regulator Transformer

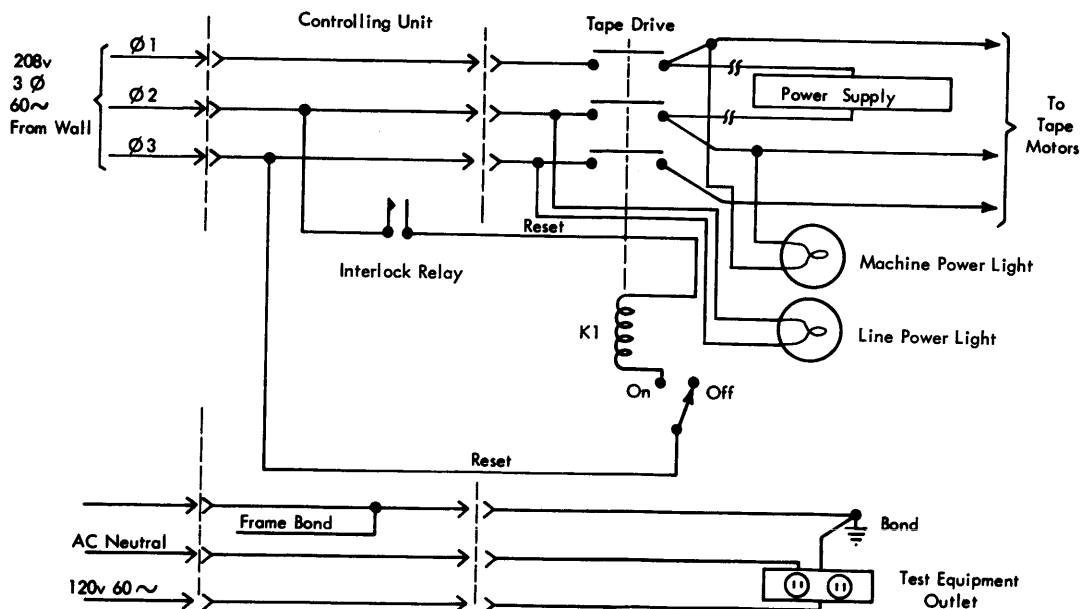

Figure 94. Tape Unit Power

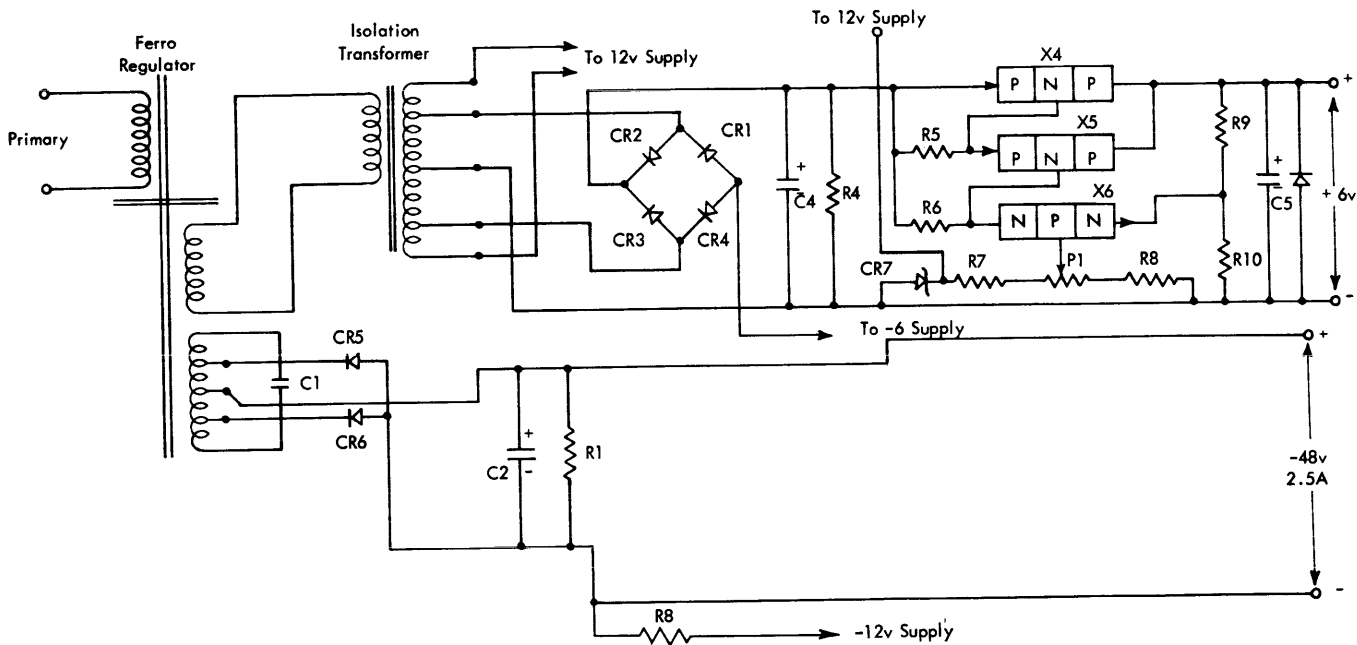

Figure 96. Phase III Power Supply

forms a ferroresonant circuit. The output voltage is held constant by the use of the shunt in the magnetic path. The shunt path with its associated air gaps allows the rate of flux change (therefore, the developed voltage) to remain substantially constant with variations of the input voltage.

### Phase III Power Supply (Figure 98)

#### - 48 Volt Supply

The -48 volt supply is a full-wave, center-tapped rectifier supply. Only limited filtering is required as this voltage is used in relay and indicator circuits. A bleeder resistor  $R_B$  is connected from the -48 volts to the -12 volt supply to help supply the heavier demands placed on that circuit by the additional NOR logic cards.

#### + 6 Volt Supply

The output of one of the ferroregulator secondaries is fed to an isolation transformer that isolates the various outputs from each other. The isolation transformer also allows rectification of several different voltages and polarities. Rectifiers CR 1, 2, 3 and 4 (Figure 96) form a full-wave, center-tapped supply. (Rectifiers CR 5 and 6 are used for the -6 supply, but a bridge configuration is used for the rectifier connections for con-

venience.) This rectified output is filtered by capacitors C4 and C5 and current is maintained by bleeder resistors. Regulation consists of controlling current flow through power transistor X4 in the following manner.

A parallel path for electron flow exists from the negative side of the line-up through the Zener diode, CR7, and through the resistor-potentiometer network consisting of R7, P1, and R8. Because there is a constant voltage drop across a Zener diode, and therefore across the network, the base of transistor X6 is held at a constant value. Transistor X6 acts as a voltage amplifier to sense a change in output voltage and develop a control signal. Transistor X5 is an emitter follower used as a current amplifier. It takes the control change on its base and develops an adequate current variation to control transistor X4, which is in series with the output power.

If the output voltage tries to increase, due to reduced loading, the following action occurs: there would be a greater voltage drop across R9 and R10. Transistor X6 becomes less forward-biased because the base is held constant by CR2 while R10 makes the emitter more positive. Reduced current flow in X6 shows up as a more positive potential on the base of X5 due to the voltage drop across R6. This reduces the forward bias on X5 and reduces current through R5. Reduced current through R5 means reduced forward bias for X4 and reduces the output voltage as was desired.



### Other Supply Circuits

Other voltages in the supply are developed in a similar manner. One is a +140 volt supply for the clutches. A -7.5 volt supply uses a pi-type filter with a choke to handle the heavy current of the prolay drive circuits.

The -6 volt supply operates the same as the +6 volt supply.

The +12 and -12 volt supplies are alike in logic. The Zener diode of the +6 volt supply controls the +12 volt supply and the Zener diode of the -6 volt supply gives a standard to the -12 volt supply also. Remember that there is a voltage drop across the power transistors in series with the output and, therefore, the supply must be capable of rectifying a voltage higher than the desired output. For example, the +12 volt supply could supply about 15 volts without the control circuitry.

Each controlled logic voltage (+12, +6, -6, -12) has a circuit protector in series, and AC circuit protectors are in series with the 208-volt input to the tape unit.

The AC test equipment outlet is powered separately and is not turned off by the power on-off switch on the tape unit.

### Power Supply Maintenance

#### VISUAL INSPECTION AND OPERATIONAL CHECK

Visually inspect the tape unit power supply for loose terminals, broken wires, damaged cables, and leaking or defective filter capacitors. Measure all power supply output voltages and waveforms and inspect functioning of all switches and lights. Check door interlocks.

In the 729 II and IV, the  $\pm 6v$  and  $\pm 12v$  power supplies should not have more than 100-mv drop in the voltage distribution system. Before checking this drop, set the 729 in write status. When the drop exceeds 1 per cent, check the distribution circuitry. Voltages at the power supply should be within +4 and -3 per cent for all cases.

There are no finite ripple specifications. The values in Figure 97 are the practical maximums to be used

Voltage	Regulation	Max Ripple (Peak to Peak)
$\pm 6v$	+4% - 3%	15mv
$\pm 12v$	+4% - 3%	100mv
-48v / 2.5 amp	$\pm 10\%$	1.5mv
-7.5v	$\pm 20\%$	100mv
+140v / 1.0amp	$\pm 10\%$ II & IV	4.5v

Figure 97. Power Supply Variations

as criteria. Maximum ripple exists with maximum current load. Ripple should be measured with the machine in a static condition to avoid confusion with load variations.

In the 729 II and IV, the circuit protectors are in the power supply series regulators so that any drop across the circuit protector is compensated for.

#### CLEANING

Vacuum the dust and dirt from the power supply and surrounding area.

#### ADJUSTMENT

Power supply voltage adjusting autotransformers or potentiometers are on the rear of the power supply at the lower right side of the tape unit. Each potentiometer is identified with the supply voltage it controls. See Figure 97 for required adjustments.

Voltages should be set with the machine in write status. Measure the  $\pm 6$  volt and  $\pm 12$  volt lines on the logic panel.

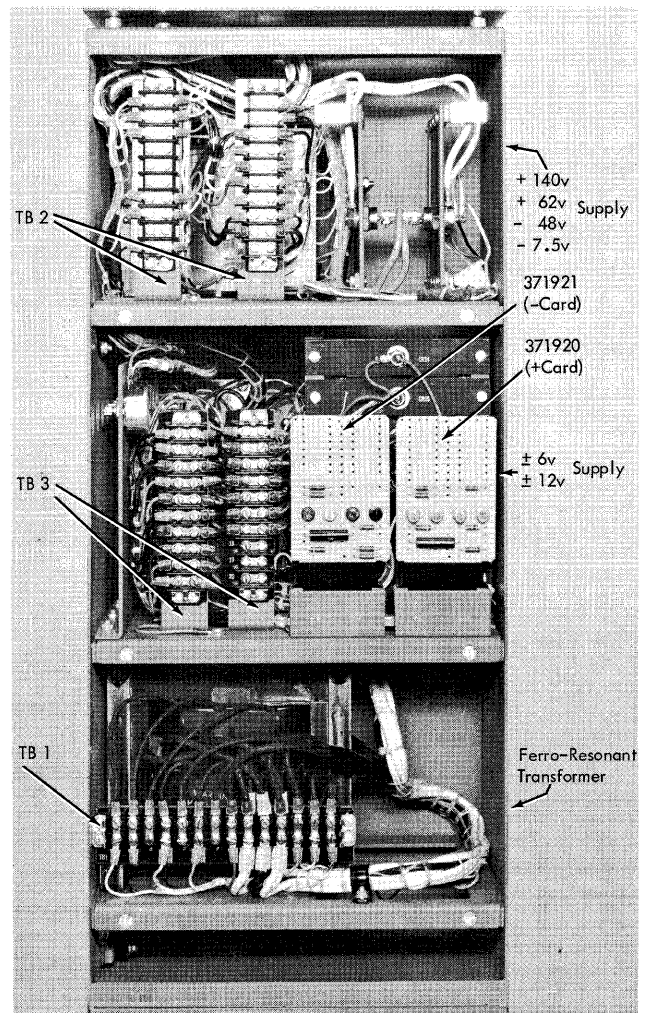

Figure 98. Phase III Power Supply Unit

## **Circuit Protectors and Thermals**

### VISUAL INSPECTION AND OPERATIONAL CHECK

Refer to Figures 7 and 32.

*Circuit Protectors:* Check circuit protectors for fault-free mechanical operation and for circuit continuity. Manually actuate each of the AC and DC CP's with power on. Check the power-on contactor for dirty or burned

points and trouble-free mechanical operation. Replace faulty circuit protectors.

*Thermals:* Check the circuitry of the high-speed rewind motor thermal. Use a dummy plug that shorts pins 1 and 2 in the connector of the thermal cable coming from the motor. Substitute this plug for the connector during a high-speed rewind operation. Under proper operation, the tape unit should immediately go into low-speed rewind.

IBM 729 II and 729 IV Magnetic Tape Units may be modified to permit switching of tape unit logic between any two magnetic tape channels that are not in operation. The tape unit switches the data and control lines through relays that are manually operated from the IBM 7155 Switch Control Console. Modified tape units may be operated with either of two tape channels of a computer system. See Figures 99 and

100. Possible operation of the modified units include connections between:

1. Two tape channels of one computer system.
2. A tape channel of two computer systems.
3. A tape channel of a computer system, and a tape channel of an off-line system.

The 7155 Switch Control Console controls as many as eight different tape units. Four keys are assigned to

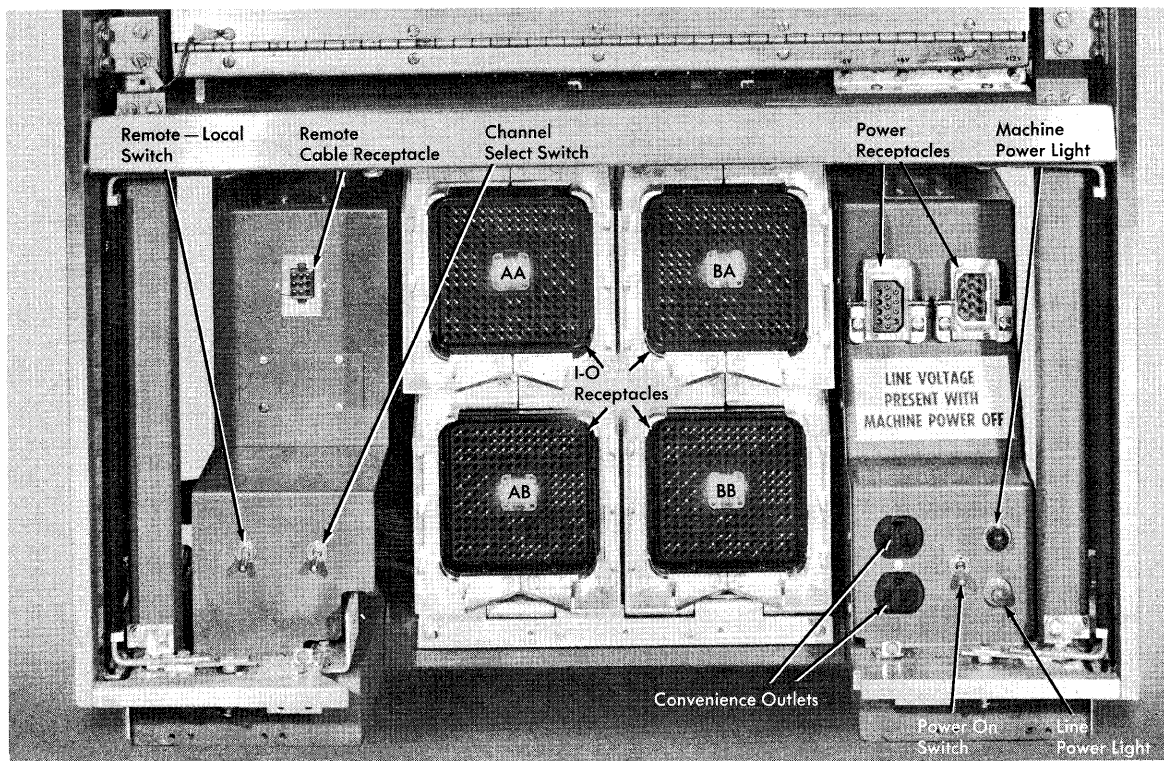

Figure 99. Tape Switching Connectors

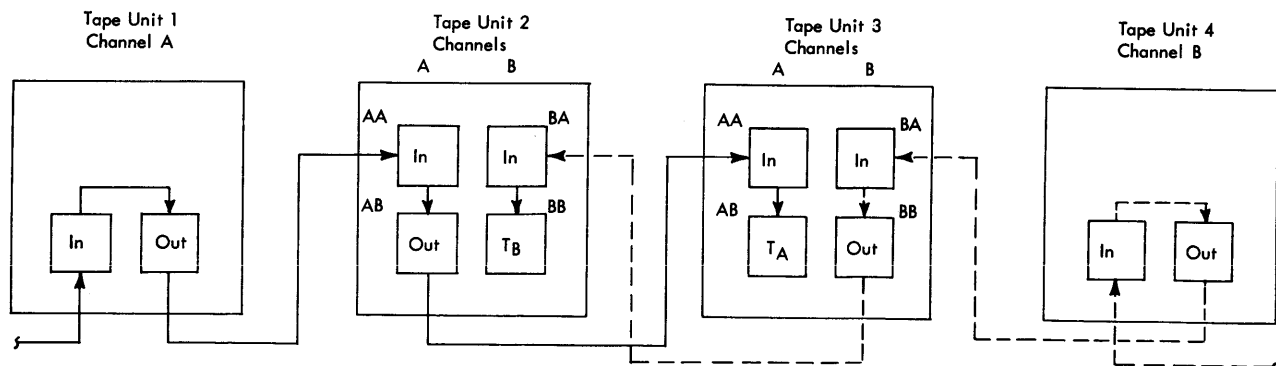
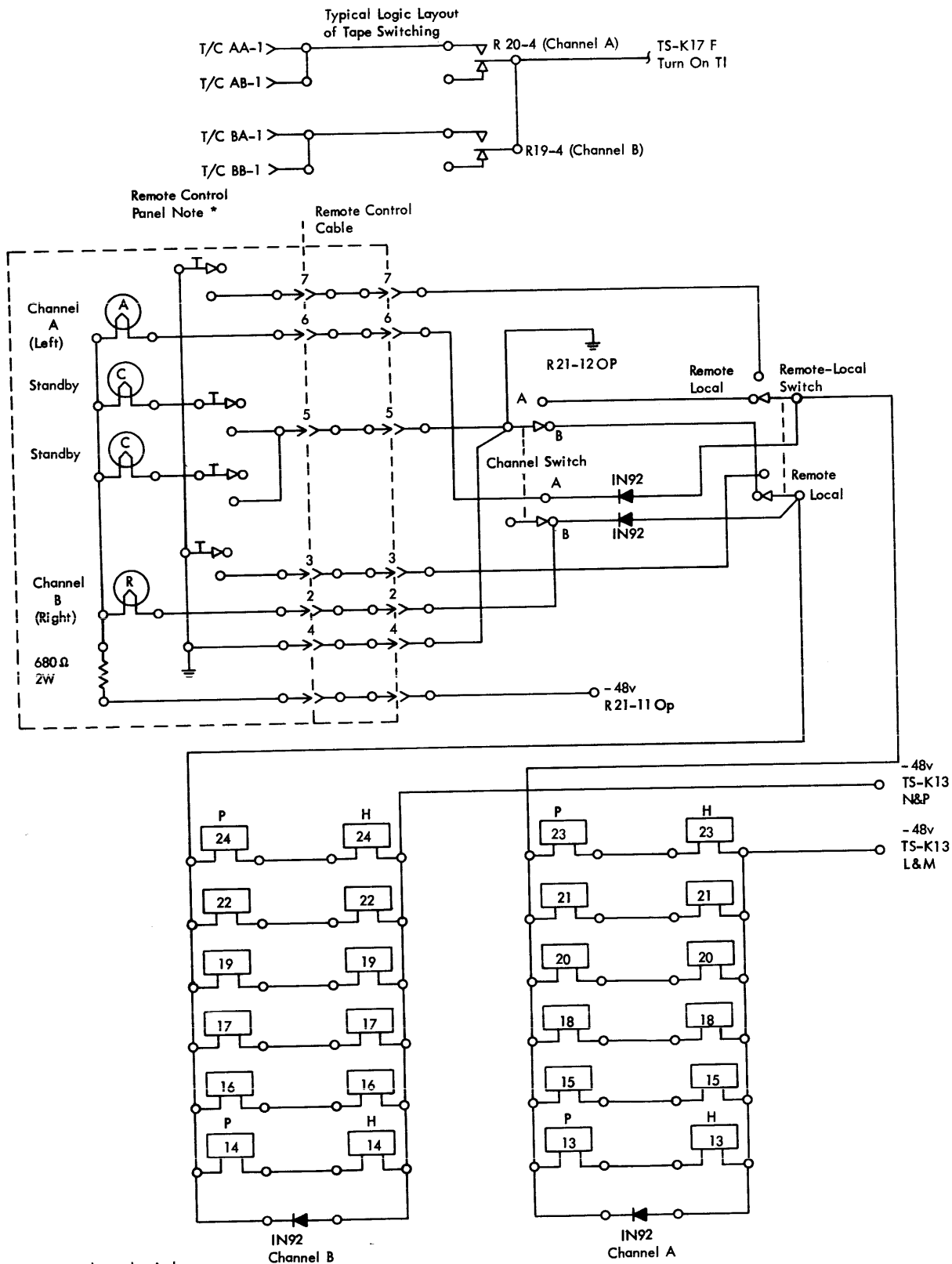

Figure 100. Receptacles and Cable Connectors with Tape Switching



Note:  
\* Remote control panel switches are interlocked. No two positions can be set at one time.

Figure 101. Tape Switching Control Circuit Diagram

each tape unit. Two keys are for a stand-by condition, where the tape unit is not connected to either channel. The other two keys select the channel to which the tape unit will be connected. The depressed key lights up, making it easy to determine the status of the tape unit.

Two toggle switches and 12 relays are added to the modified tape unit (Figures 99, 100, 101, and 102). One of the toggle switches is the remote-local control (R/L). When the R/L switch is in the REMOTE position, the

7155 Switch Control Console controls the tape unit. If the R-L switch is in the LOCAL position, the tape unit is under control of the other toggle switch, labeled A-B. The A-B switch controls the channel with which the tape unit is associated.

The relays are in groups of six, each group controlling the lines entering and leaving the tape unit. Only one group of relays can be energized at one time. The energized relays select the channel that controls the tape unit.

T/C	Name	Channel A Relay Contact	Channel B Relay Contact	T/C	Name	Channel A Relay Contact	Channel B Relay Contact
1	Turn On TI	R20-04	R19-04	88	Select TU 3	R21-06	R22-06
2	Turn On TI (Shield)	-	-	89	Select TU 3 (Shield)	-	-
3	Turn Off TI	R18-08	R17-08	92	Read Bus 4 (Shield)	-	-
4	Turn Off TI (Shield)	R18-07	R17-07	93	Read Bus 4	R13-07	R14-07
5	GO	R18-10	R17-10	94	Read Bus 8 (Shield)	-	-
6	GO (Shield)	R18-09	R17-09	95	Read Bus 8	R13-06	R14-06
7	Backward	R20-02	R19-02	96	Select TU 4	R21-07	R22-07
8	Backward (Shield)	R20-01	R19-01	97	Select TU 4 (Shield)	-	-
9	Start Rewind	R20-07	R19-07	98	Select TU 5	R21-08	R22-08
10	Start Rewind (Shield)	R20-06	R19-06	99	Select TU 5 (Shield)	-	-
11	Set Wr Status	R20-03	R19-03	102	Read Bus A	R13-05	R14-05
12	Set Wr Status (Shield)	-	-	103	Read Bus A (Shield)	-	-
13	Set Rd Status	R20-10	R19-10	104	Read Bus B	R13-04	R14-04
14	Set Rd Status (Shield)	R20-09	R19-09	105	Read Bus B (Shield)	-	-
16	Reserved	-	-	106	Select TU 6	R21-09	R22-09
17	Reserved (Shield)	-	-	107	Select TU 6 (Shield)	-	-
18	Spare	-	-	108	Select TU 7	R21-10	R22-10
19	Spare (Shield)	-	-	109	Select TU 7 (Shield)	-	-
20	Select & Ready M4	R15-12	R16-12	112	Read Bus C	-	-
21	Select & Ready M4 (Shield)	R15-11	R16-11	113	Read Bus C (Shield)	R13-03	R14-03
22	Select & TI On	R18-02	R17-02	114	Spare (Shield)	-	-
23	Select & TI On (Shield)	R18-01	R17-01	115	Spare	-	-
24	Sel & TI Off (Shield)	R18-03	R17-03	116	Select TU 8 (Shield)	-	-
25	Sel & TI Off	R18-04	R17-04	117	Select TU 8	R13-01	R14-01
26	Sel & at LP (Shield)	R15-05	R16-05	118	Select TU 9 (Shield)	-	-
27	Sel & at LP	R15-06	R16-06	119	Select TU 9	R13-02	R14-02
28	Sel & Not at LP (Shield)	R15-07	R16-07	122	Spare	-	-
29	Sel & Not at LP	R15-08	R16-08	123	Spare (Shield)	-	-
31	Select & Ready M2	R15-12	R16-12	124	Spare	-	-
32	Select & Ready M2 (Shield)	R15-11	R16-11	125	Spare (Shield)	-	-
33	Sel Rdy & Read	R15-04	R16-04	171	Write Bus 1 (Shield)	R23-01	R24-01
34	Sel Rdy & Read (Shield)	R15-03	R16-03	172	Write Bus 1	R23-02	R24-02
35	Sel Rdy & Write	R15-02	R16-02	173	Write Bus 2 (Shield)	-	-
36	Sel Rdy & Write (Shield)	R15-01	R16-01	174	Write Bus 2	R23-03	R24-03
37	Select & Rewind	R18-06	R17-06	175	Write Bus 4 (Shield)	-	-
38	Select & Rewind (Shield)	R18-05	R17-05	176	Write Bus 4	R23-04	R24-04
39	Rewind & Unload	R18-11	R17-11	177	Write Bus 8 (Shield)	-	-
40	Rewind & Unload (Shield)	-	-	178	Write Bus 8	R23-05	R24-05
41	Set High Density	R18-12	R17-12	179	Write Bus A (Shield)	R23-06	R24-06
42	Set High Density (Shield)	-	-	180	Write Bus A	R23-07	R24-07
43	Set Low Density	R20-05	R19-05	181	Write Bus B (Shield)	-	-
44	Set Low Density (Shield)	-	-	182	Write Bus B	R23-08	R24-08
46	High Density	R15-10	R16-10	183	Write Bus C (Shield)	-	-
47	High Density (Shield)	R15-09	R16-09	184	Write Bus C	R23-09	R24-09
48	Reserved	-	-	186	Spare	-	-
49	Reserved (Shield)	-	-	187	Spare (Shield)	-	-
76	Select TU 0 (Shield)	-	-	188	Spare	-	-
77	Select TU 0	R21-03	R22-03	189	Spare (Shield)	-	-
78	Select TU 1 (Shield)	-	-	190	Spare	-	-
79	Select TU 1	R21-04	R22-04	191	Spare (Shield)	-	-
82	Read Bus 1	R13-09	R14-09	192	Write Echo	R23-12	R24-12
83	Read Bus 1 (Shield)	R13-10	R14-10	193	Write Echo (Shield)	R23-11	R24-11
84	Read Bus 2	R13-08	R14-08	194	Write Check Char	R20-08	R19-08
85	Read Bus 2 (Shield)	-	-	195	Write Check Char (Shield)	-	-
86	Select TU 2	R21-05	R22-05	196	Write Pulse	R23-10	R24-10
87	Select TU 2 (Shield)	-	-	197	Write Pulse (Shield)	-	-

Figure 102. Tape Switching Relay Chart

# IBM 729 V and VI Magnetic Tape Units

## Characteristics

The IBM 729 v and vi Magnetic Tape Units operate at an increased character density of 800 characters per inch in addition to the character densities of 200 and 556 characters per inch. This means that each 729 v and vi tape unit is able to write or read at 200/556, 200/800, or 556/800 characters per inch. The maximum character rate is increased to 60,000 characters per second on the 729 v and 90,000 characters per second on the 729 vi tape units. The 729 v and vi tape units are identical to the 729 ii and iv tape units, except for the 800-character per inch recording ability. Characteristics of the tape units at all densities are shown in Figure 103.

The pair of recording densities at which a given tape unit operates is controlled by a three-position switch on the tape control device used with the tape unit. With the switch in position 1, tape units (both 729 v and vi) attached to the tape control operate in either 200 or 556 character per inch recording densities. Both program instruction and the change density switch on the tape unit itself specify either high or low density recording. For example, a set density low instruction addressing a tape unit whose tape control has the density select switch set in position 1, would read or write at 200 characters per inch. With the switch in position 2, recording densities of 200 and 800 characters

Characteristic	729 V			729 VI		
	Tape Speed-- (inches per second)	75			112.5	
Record Density-- (characters per inch)	200	556	800	200	556	800
Maximum Data Rate-- (characters per second)	15,000	41,667	60,000	22,500	62,500	90,000
Character Time-- (microseconds per character)	67	24	17	44	16	11
Average Access Time-- (milliseconds)	10.8			7.3		

Figure 103. 729 v and vi Magnetic Tape Unit Characteristics

Density Switch Position	729 V Density Mode		729 VI Density Mode	
	Low	High	Low	High
1. 200/556	15,000	41,667	22,500	62,500
2. 200/800	15,000	60,000	22,500	90,000
3. 556/800	41,667	60,000	62,500	90,000

Figure 104. Density Switch Positions

per inch are used, and with position 3, 556 and 800 characters per inch are used. Figure 104 shows all possible switch settings together with the resultant character rates in characters per second.

## Operation and Adjustments

The main areas of change for the 729 v and vi are increased mechanical stability of the tape transport, write head current compensation to achieve pulse asymmetry, and frequency compensated preamplifiers.

### Read Circuits and Adjustments

#### PREAMPLIFIER GAIN

As in 729 ii and iv, different preamplifier cards are required for the 729 v and vi. The preamplifier gain should be adjusted to an average of 10.0 volts peak-to-peak while writing at high density (800 characters per inch).

#### FLUTTER

Flutter may be caused by tape having scalloped edges or the width not being within specifications. Another cause could be defective nylon pulleys or excessive end play of the pulleys (usually the left). End play should not exceed 0.003 inch.

Flutter must not exceed 0.5  $\mu$ s on the 729 vi or 0.75  $\mu$ s on the 729 v while writing all ones.

#### READ SKEW

Read skew shall not be greater than .25  $\mu$ s between negative peaks of leading and lagging tracks as measured at the read bus using master tape P/N 461197.

After completion of the read skew adjustment, load and unload the tape unit a minimum of five times. After each loading operation, observe the relative skew between the 1 and C bits while reading the master tape. This skew should not exceed 0.5  $\mu$ s.

### Write Circuits and Adjustments

#### WRITE PULSE ASYMMETRY

Two YEU potentiometer cards have been placed in the write circuitry to provide a potentiometer between each driver and the head coils (see Figure 105). By

adjusting the potentiometer on the card it is possible to vary the current in one head. Because the amount of current affects the circuit response time, increasing or decreasing the current can cause a time shift in writing on tape.

#### WRITE PULSE ASYMMETRY ADJUSTMENT

This adjustment is made by writing all ones from the associated TAU or channel and observing the skew register A output. Sync negative internal and observe

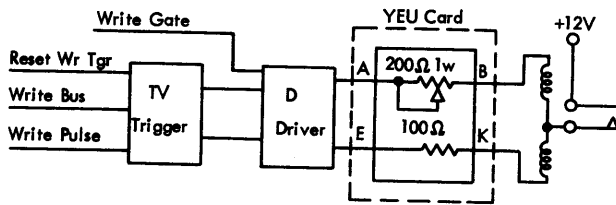

Figure 105. Write Current Compensation

the first pulse after the sync pulse. Adjust the potentiometer for the track until the pulses from the positive and negative signals are coincident. NOTE: This adjustment is to be made before setting write skew.

#### WRITE SKEW ADJUSTMENT

This adjustment is to be made after the write pulse asymmetry adjustment. Write skew shall not exceed  $0.27 \mu\text{s}$  between leading and lagging tracks measured at the read bus after read skew has been set with a master tape.

#### WRITE CURRENT

After adjustment for write pulse asymmetry, the write current must not be less than 37 ma.

#### I-O Connectors

"Select and ready" for the 729 v and v<sub>I</sub> is located at τ/c receptacle connections 114 and 115. If 729 II and IV units are used on the same bus with 729 v and v<sub>I</sub> units, τ/c 114 and τ/c 115 must be connected between receptacle A and B to provide continuity for the 729 v and v<sub>I</sub> line.

## Special Component Circuits

Operation of some transistor circuits in the IBM 729 Magnetic Tape Units may be difficult to analyze from the systems block diagrams. This section shows these circuits in schematic form and contains brief explanations of their operation.

### Read Preamplifier

The input to the preamplifier (Figure 106) is a small voltage, about 15 to 35 millivolts peak-to-peak, developed across the read coil by changes in flux as bits are read from tape. The signal level fed to the external control as a result of reading a bit from tape must be 8.8v peak-to-peak. Thus, the over-all gain of the preamplifier must be about 500.

When the input voltage shifts in a positive direction the collector current of transistor T1 decreases, causing the collector to become more negative. This negative shift is coupled directly to the base of transistor T2, causing its collector current to decrease. This results in an amplified positive shift at the collector of T2.

At this point the shift is capacity-coupled to the base of transistor T3, which is held at about 6v by the voltage divider network made up of a 2.7K and a 8.25K resistor between +12v and -12v. The positive shift applied to the base of T3 reduces its conduction, causing a negative shift at its collector. Note that a positive shift on the base of T3 also causes a positive shift on its emitter. This shift is capacity-coupled back to the first stage (T1) emitter where it produces degeneration. The 100-ohm potentiometer in the emitter circuit of T1 determines the amount of negative feedback and controls the gain of the amplifier.

The collector output signal of T3 passes through a delay line (not shown) before it reaches the base of transistor T4. The delay line makes it possible to add small increments of delay to the signal to compensate for manufacturing tolerances in the read head.

The negative shift collector output of T3 is capacitor-coupled to the base of T4, driving it more into conduction. This produces a positive shift output which feeds directly into the base of T6.

The emitter follower output stage, T6, feeds the amplified read signal to the external control. The emitter load is in the external control, as indicated in Figure 106.

There is no signal gain realized from the T4 circuit; its function is to act as an isolation stage and allow

the output transistor to drive more cable length (capacitance) without oscillation.

Transistor T5 functions as a gate for the preamplifier output. The base of transistor T5 is connected to the junction of a voltage divider. One end of this divider is connected to +12v. The other end of the divider may be either +6v or -6v (read gate). The emitter of T5 is connected directly to +6v. The collector connects directly to the base of T6. When the read gate is at a +6v level, the base of T5 is positive in reference to its emitter and, because it is a PNP transistor, it will be reverse biased (cut-off). In this condition T5 appears as a high resistance across the base circuit of T6 and has no effect on preamplifier operation.

When the read gate is at its down level (-6v), the base of T5 is negative in reference to its emitter (forward biased) and T5 conducts heavily. T5 now appears as a low resistance across the input to the emitter follower and prevents any change in level at this point. This, in turn, prevents any output from the emitter follower stage. The read gate is up (+6v) when the tape unit is selected and ready.

### Write Trigger

The write trigger (Figure 107) is a voltage mode, self-gated binary input trigger. Each time a sample pulse (write pulse) is applied to the binary input, the trigger changes its status (flips), providing it is first conditioned by an up level on the gate input.

To understand the circuit, consider transistor T3 conducting and transistor T2 cut off. At this time the voltage at the collector of T3 is 0v. Because the collector of T3 is connected directly to the base of the emitter follower (T1), the voltage level at the emitter of T1 will also be 0v. At this time the voltage divider (R28 and R5) will have about +1.65v at its junction. This positive level on the base of T2 keeps it cut off.

Because T2 is cut off, its collector tends to go to -12v but will be clamped at -6v by the action of the emitter follower T4. The -6v on the base of T4 produces a -6v level on its emitter, causing the junction of the voltage divider (R10 and 11) to tend to go to -2.7v; however, transistor T3 being in conduction clamps the junction at 0v. In this status the left output is 0v; the right output is -6v.





Before attempting to flip the trigger with a write pulse, the self-gated binary input should be considered. Transistors T3 and T2 each have an input voltage divider consisting of R37, R40, and R17, R18, respectively. The junction of these dividers is connected to the base of T3 and T2 through diodes D1 and D2.

Assuming the output levels previously stated and an up level (0v) on the gate input, the junction of the left input divider R37, R40 will be at 0v. At the same time, the junction of the right divider will be at -3v level.

The write pulse is capacity-coupled to both input dividers through capacitors C1 and C2. Note that when the write pulse occurs, a 3v positive shift will be applied to the junctions of both input dividers. Because diode D2 is reverse biased by about 4.65v (+1.65v cathode, -3v anode) the 3v pulse will have no effect on transistor T2. Diode D1, however, has no reverse bias at this time and the 3v positive shift is applied to the base of T3, cutting it off. As T3 cuts off, its collector voltage drops to -6v, causing the emitter of T1 to become -6v. This action causes the junction of the voltage divider (R28 and R5) to head toward a 2.7v level; however, T2 will conduct, clamping the junction at 0v. With T2 conducting, T4 has 0v on its emitter. This action produces +1.65v at the junction of voltage divider R10 and R11, holding T3 cut off.

The trigger has now changed status and the outputs will be: left output, -6v; right output, 0v. Note that diode D1 is reverse biased and when the next write pulse occurs, it passes through D2, flipping the trigger back to its original status (assuming gate is still up).

Write pulses occur at regular intervals during a write operation; however, we want only a particular write trigger to flip if there is information to be written.

When no information is on the write bus, the gate input (Figure 107) is at -12v for the associated trigger. This holds the junction of both input dividers negative enough to prevent the write pulses (+3v shift) from having any effect on either transistor T3 or T2.

Writing a check character will be accomplished by a reset to the trigger. If the trigger is on just prior to the time the reset occurs, T3 is cut off and T2 is conducting. The negative shift at the base of T3 will cause it to go into conduction and reverse the status of the trigger in a manner similar to that just explained.

## Head Driver and Echo Pulse Amplifier

The purpose of this circuit (Figure 108) is to alternately pass current through one half of the write coil, then the other, under control of the write trigger. The circuit also produces an "echo" pulse each time current is switched in the write coil. The echo pulse is an indication to the external control that a character has been written.

Transistors T1 and T2 have their base connected to the junctions of voltage dividers and to the right and left outputs of a write trigger; when one input is at 0v level, the other is at -6v.

Note that a third input is connected to the base of transistor T4 through a voltage divider. This input is the write status gate and is above -6v when the tape unit is in write status. When the gate is above -6v, the junction of the divider tends to rise above -6v but is clamped because T4 goes into conduction. Transistor T4 acts as a switch, completing a current path for T1 or T2 to -6v only when the tape unit is in write status. When the tape unit is not in write status, transistor T4 is cut off, causing the emitters of T1 and T2 to be at a +6v. In this state, an up level to the base of either T1 or T2 cannot switch the write transistors.

Consider the following conditions: The gate input is active, thus T4 is in full conduction and acts as a low resistance. The left input is 0v and the right input is -6v. This causes T1 to conduct while T2 is cut off. With T1 conducting, current flows from -6v through T4 and T1 through the left half of the write coil, through the NFP relay contacts to +12v.

As long as current flows in the left half of the write coil, tape is magnetized to one level of saturation. Consider now the operation when the write trigger is flipped. The right input rises to 0v and the left input falls to -6v. This cuts off T1 and puts T2 into conduction. Current now flows from -6v through T4 and T2, through the right half of the write coil to +12v. With current flowing in the right half of the write coil, tape will be magnetized in the opposite direction.

The echo amplifier consists of transistor T3 and its two input circuits. Transistor T3 is normally reverse-biased so it is not in conduction. Transistor T3 has two input circuits: capacitor C1, diode D1, and capacitor C2, diode D2. Coupling capacitors C1 and C2 are coupled to the collectors of T1 and T2, respectively. When T1 conducts, its collector is at -6v; at this time T2 is cut off and its collector is at +12v. When current is switched in the write coil, the voltage at the collector of T1 rises to +12v, while the voltage at the collector of T2 drops to -6v. This causes a

positive shift of 18v on diode D1 but does not reach the base of T3 because of the polarity of the diode. At the same time, an 18v negative shift is applied to diode D2; because this is a negative shift, it reaches the base of transistor T3, causing it to conduct momentarily.

### Load Point and End-of-Reel Photosensing

Two identical photosensing circuits are employed in the 729 Tape Units: one for sensing the load point reflective spot, the other for sensing the end-of-reel reflective spot. These circuits use a photocell that changes resistance when exposed to light. When dark, the photocell acts as a high resistance. When illuminated by light from the reflective spot on tape, the resistance of the cell drops.

### Circuit Description (Figures 109 and 110)

The ac Photo-amplifier consists of an input emitter follower (T1) receiving the signal from the photocell, a Schmitt trigger, consisting of T2 and T3 to shape the input wave, a single-shot at T4, and an output inverter at T5.

Transistors T2 and T3 with their associated resistors and capacitor form a Schmitt trigger. R10 and R11 act as a voltage divider network to establish a reference level of approximately  $-3.8\text{v}$  at the base of T2. The resistor network of R13, R37, and R36 produce a T3 base voltage of about  $-1.8\text{v}$ . With the emitters of both T2 and T3 tied to a common point, the transistor with the most positive base is conducting. T3 conducting places its emitter and the emitter of T2 at  $-1.8\text{v}$  ( $-2.0\text{v}$  considering a drop across the junction), proving that T2 will be reverse biased and cut off.

T4 in its quiescent state is conducting because of its base being returned to  $-12\text{v}$ . Resistors R44 and R45 produce a level of about  $+7.5\text{v}$  at the base of the inverter, T5, cutting it off and giving a  $-12\text{v}$  ( $-S$ ) output.

The internal resistance of a dark photocell is high, causing the base of the input emitter follower T1 to be at a minus level and cut off. The type of output from the photocell is conditioned by a number of factors such as tape speed, tape position, and intensity of light. The resulting signal must, however, have an amplitude of  $2.5\text{v}$  with the up level lasting for  $50\ \mu\text{s}$ .

Reflected light from the T1 lamp causes the internal resistance of the photocell to be greatly reduced. As a

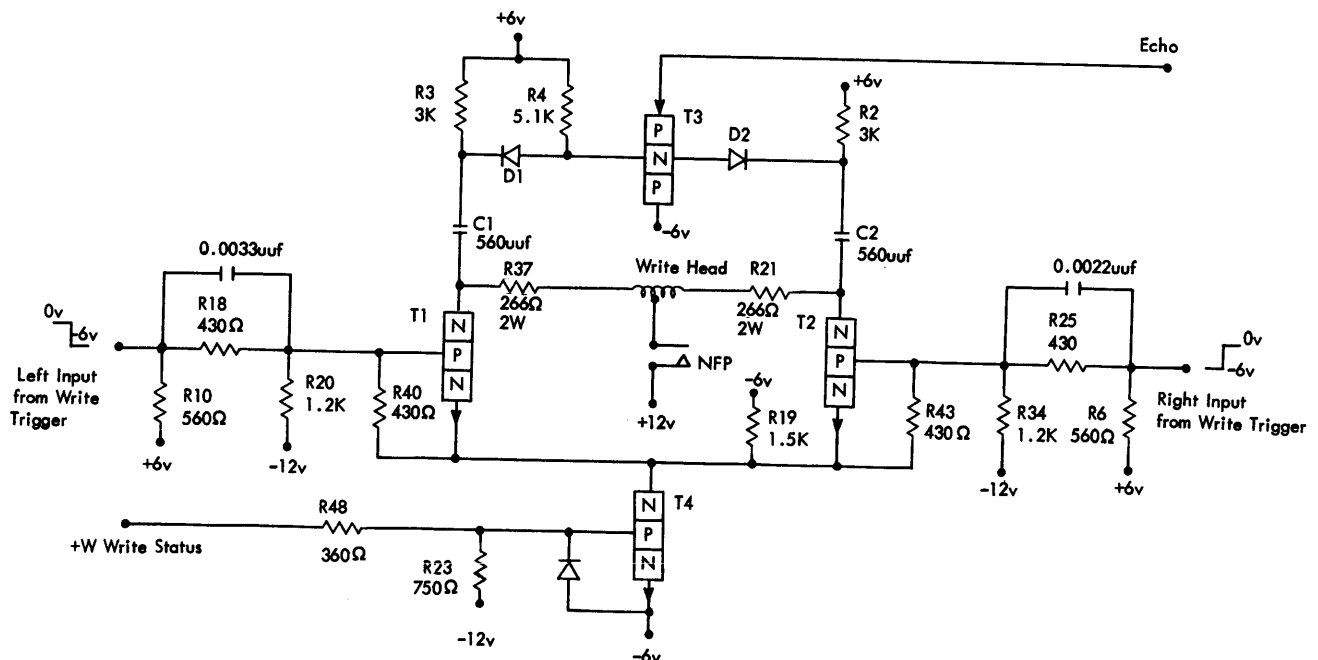

Figure 108. Driver and Echo Pulse Amplifier

result, current flows through R27 (current limiting resistor) and causes the base voltage to rise. This, in turn, causes T1 to conduct and pass the input pulse through C1 to the base of T2.

This positive pulse raises the base of T2 above  $-1.8\text{v}$  and throws it into conduction. At the same time, the emitters of both T2 and T3 rise to the T2 base level, cutting off T3. The increased current flow through R13 causes a negative shift to be felt at the base of T3 via the speedup capacitor, resulting in a very fast flip time of T3 and a well-defined square pulse at the T3 collector.

In the normal state, the collector of T3 was trying to go to  $-1.8\text{v}$  but was being held to ground by the diode. With T4 conducting, the capacitor C2 has  $+12\text{v}$  at the right plate and ground on the left. When the Schmitt trigger flips, T3 cuts off and allows its collector to rise toward  $+12\text{v}$ . A positive  $10\text{v}$  pulse (allowing for a drop in the R17 resistor) is then sent through capacitor C2 and to the base of T4. The base rising to a  $+22\text{v}$  cuts off the transistor and allows T5 to conduct, giving a  $0\text{v}$  ( $+S$ ) output.

The diode at this point is reverse-biased and out of the picture completely. The single-shot circuit, T4, times out through R17, C2, and R40, and the base of T4 heads exponentially for  $-12\text{v}$  (a swing of  $34\text{v}$ ). As the base approaches  $+12\text{v}$ , however, T4 again goes into conduction and brings the output of T5 to a  $-S$  level. The output pulse is a good  $10\ \mu\text{s}$  square wave because the cut off of T4 occurs on the steep portion of the exponential curve.

### CD-- (CTRL Three-Way PNP Nontranslating Circuits)

The CD-- card consists of three 3-way PNP nontranslating circuits used for repowering and level setting of CTRL signals. This circuit is sometimes called the NOR circuit. Each circuit on the card performs a basic logic function ( $+A$ ,  $-O$ ,  $I$ ) and inverts the S input signal. The logic function is performed by the input resistor network and the invert function is accomplished by the common emitter transistor configuration. Collector loading for Figure 111 differs from

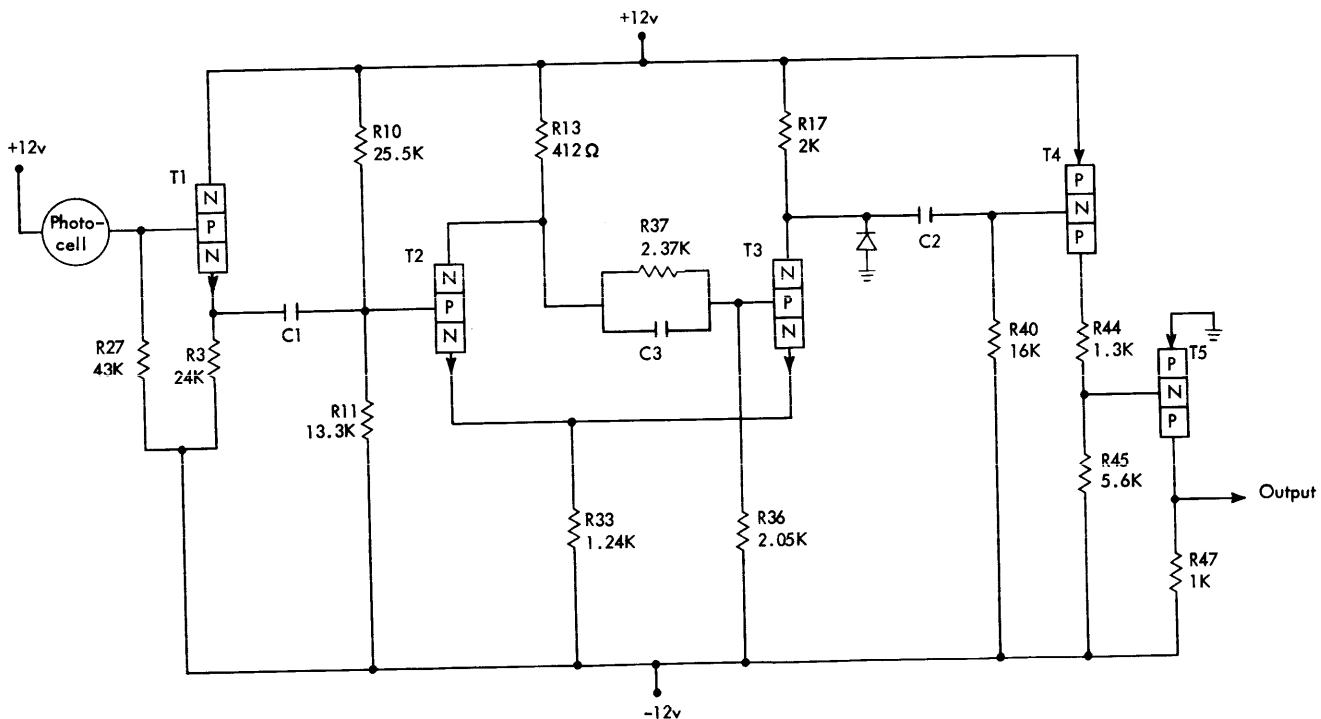

Figure 109. AC Photocell Circuit

that of Figure 112 and permits flexibility in driving external loads. In the -OR logic application shown, a +S output is obtained whenever a -S level occurs at any of the input points.

**Circuit Description**

The base of T4 is biased by the voltage developed across the input divider network. The exact level of the bias depends on the number of inputs used and their level. Input levels may vary at their low levels (-S), but all reach ground potential at the +S level. When +S levels exist at all the input pins, T4 base is at +0.65v. The transistor is reverse-biased off as its emitter is returned to ground. Current flow from the -12v supply through the 1.6K collector resistor to the load divider network gives a -10.3v off output.

Dropping any input to the -S level causes T4 base to decrease toward -3.15v. T4 becomes forward-

biased on and clamps the base at -0.2v. Saturation current flows through the transistor and quickly raises the output to the +S level (-0.2v). Coincidence of more than one -S level at the input, drives the transistor farther into saturation and increases the turn-off delay of the circuit.

DOT'ing the collectors (sharing of a common collector load by similar outputs) does not perform another level of logic, but merely increases the number of inputs. These inverter circuits are also combined with other CTRL logic circuits to make up trigger and latch configurations.

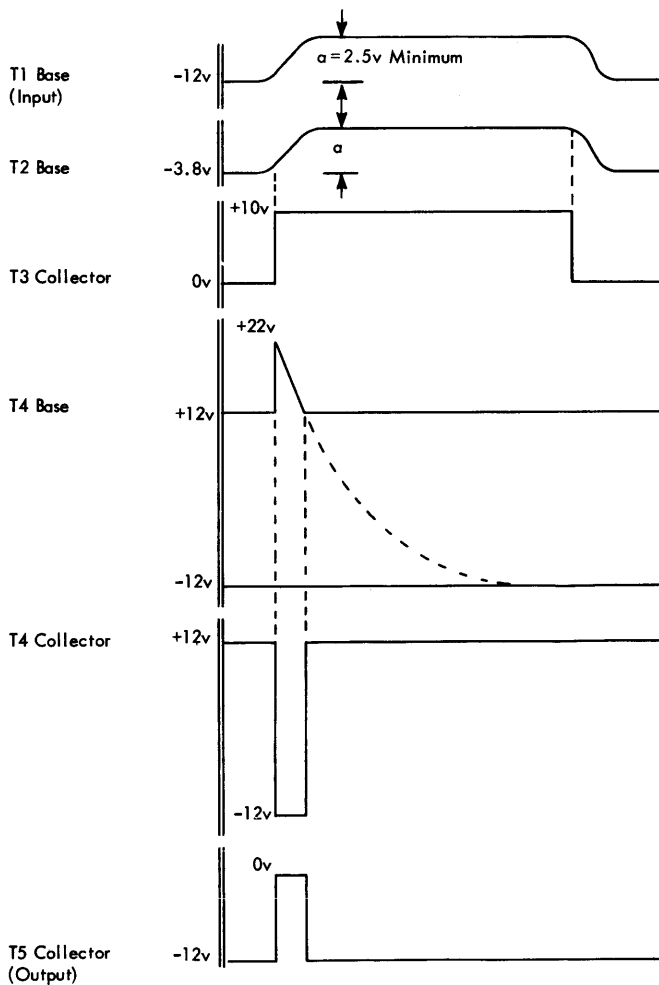

Figure 110. AC Photocell Wave Shapes

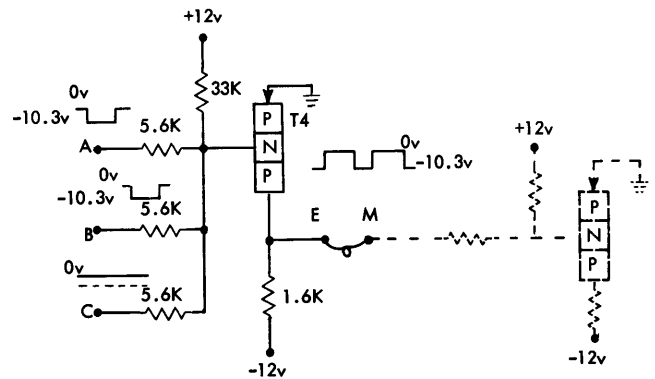

Figure 111. CD— Circuit Configuration

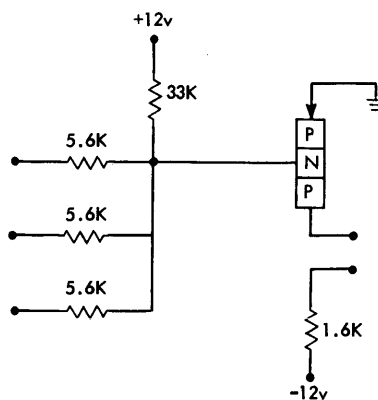

Figure 112. CD— Circuit (Extender)

COMMENT SHEET

IBM 729 II, IV, V, VI MAGNETIC TAPE UNITS

CUSTOMER ENGINEERING INSTRUCTION-REFERENCE, FORM 223-6988

FROM

NAME \_\_\_\_\_

OFFICE NO. \_\_\_\_\_

FOLD

CHECK ONE OF THE COMMENTS AND EXPLAIN IN THE SPACE PROVIDED

SUGGESTED ADDITION (PAGE \_\_\_\_\_ , TIMING CHART, DRAWING, PROCEDURE, ETC.)

SUGGESTED DELETION (PAGE \_\_\_\_\_ )

ERROR (PAGE \_\_\_\_\_ )

EXPLANATION

CUT ALONG LINE

FOLD

FOLD

FOLD

NO POSTAGE NECESSARY IF MAILED IN U. S. A.  
FOLD ON TWO LINES, STAPLE, AND MAIL

STAPLE

STAPLE

OLD

FOLD

FIRST CLASS  
PERMIT NO. 81  
POUGHKEEPSIE, N. Y.

**BUSINESS REPLY MAIL**  
NO POSTAGE STAMP NECESSARY IF MAILED IN U. S. A.

POSTAGE WILL BE PAID BY  
IBM CORPORATION  
P. O. BOX 390  
POUGHKEEPSIE, N. Y.

ATTN: CE MANUALS, DEPARTMENT 296

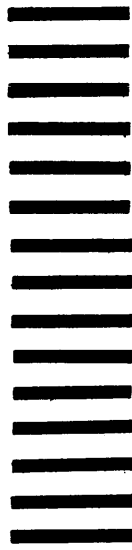

CUT ALONG LINE

OLD

FOLD

STAPLE

STAPLE