

EK-P500B-SV-002

*VAXmate*<sup>TM</sup>  
*Service Guide*

**digital**<sup>TM</sup>

*VAXmate*<sup>TM</sup>  
*Service Guide*

**September 1986 May 1987**

© Digital Equipment Corporation 1987. All Rights Reserved.

The information in this document is subject to change without notice and should not be construed as a commitment by Digital Equipment Corporation. Digital Equipment Corporation assumes no responsibility for any errors that may appear in this document.

The software described in this document is furnished under a license and may only be used or copied in accordance with the terms of such license.

No responsibility is assumed for the use or reliability of software on equipment that is not supplied by DIGITAL or its affiliated companies.

MS-DOS is a trademark of Microsoft Corporation.

The following are trademarks of Digital Equipment Corporation:

|                  |              |                |
|------------------|--------------|----------------|
| <b>digital</b> ™ | DIBOL        | RSX            |
| DEC              | MASSBUS      | UNIBUS         |
| DECmate          | PDP          | VAX            |
| DECSYSTEM-10     | P/OS         | VMS            |
| DECSYSTEM-20     | Professional | VT             |
| DECUS            | Rainbow      | Work Processor |
| DECwriter        | RSTS         |                |

Printed in U.S.A.

# Contents

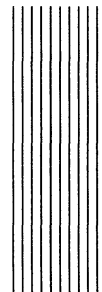

## Chapter 1 Overview

|   |      |
|---|------|
| 1.1 Introduction .....  | 1-1  |
| 1.2 VAXmate Workstation Components .....                          | 1-3  |
| 1.2.1 Monitor (Amber or Green Screen) .....                       | 1-6  |
| 1.2.2 I/O Board .....   | 1-6  |
| 1.2.2.1 Communications Port .....                                 | 1-6  |
| 1.2.2.2 Printer Port .....  | 1-6  |
| 1.2.3 CPU Board .....   | 1-8  |
| 1.2.4 Power Supply .....  | 1-8  |
| 1.2.5 RX33 1.2 Mbyte Diskette Drive .....                         | 1-8  |
| 1.2.6 Keyboard .....  | 1-9  |
| 1.2.7 Mouse .....   | 1-9  |
| 1.2.8 ThinWire Ethernet Cable .....                               | 1-9  |
| 1.2.9 Options .....   | 1-9  |
| 1.2.9.1 2 Mbyte Memory .....                                      | 1-10 |
| 1.2.9.2 80287 Coprocessor .....                                   | 1-10 |
| 1.2.9.3 Expansion Box .....                                       | 1-10 |
| 1.2.9.4 Integral Modem Board for North America .....              | 1-10 |
| 1.2.9.5 LA75 Printer .....  | 1-10 |
| 1.2.9.6 LN03 Plus Printer .....                                   | 1-11 |
| 1.2.10 DIGITAL ThinWire Ethernet Multiport Repeater (DEMPR) ..... | 1-11 |
| 1.2.11 DIGITAL ThinWire Ethernet Station Adapter (DESTA) .....    | 1-11 |
| 1.3 Environmental and Electrical Description .....                | 1-11 |

## Chapter 2 Troubleshooting the VAXmate Workstation

|                              |     |
|------------------------------|-----|
| 2.1 Introduction .....       | 2-1 |
| 2.1.1 Diagnostic Tests ..... | 2-1 |
| 2.1.1.1 Power-Up Test .....  | 2-1 |





|         |   |      |
|---------|---|------|
| 2.1.1.2 | Extended Self-Test .....                        | 2-2  |
| 2.1.1.3 | Service Diagnostics .....                       | 2-3  |
| 2.1.2   | Light Emitting Diodes (LEDs) .....              | 2-3  |
| 2.2     | Troubleshooting Procedure .....                 | 2-5  |
| 2.3     | Power-Up Test .....                             | 2-6  |
| 2.3.1   | System Halt .....                               | 2-15 |
| 2.3.2   | CPU Board Jumpers .....                         | 2-15 |
| 2.3.3   | Error Numbers .....                             | 2-16 |
| 2.3.4   | What To Do If the VAXmate Power Shuts Down..... | 2-18 |
| 2.3.4.1 | Thermal Shutdown/Overvoltage .....              | 2-19 |
| 2.3.4.2 | Overcurrent Shutdown .....                      | 2-19 |
| 2.3.4.3 | Blown Fuse or Short Circuit.....                | 2-20 |
| 2.4     | Extended Self-Test .....                        | 2-22 |
| 2.4.1   | Exceptions to Testing Results.....              | 2-26 |
| 2.4.1.1 | If the Customer Reports a Modem Problem.....    | 2-26 |
| 2.4.1.2 | New Expansion Box .....                         | 2-26 |
| 2.4.1.3 | New Hard Disk in Expansion Box.....             | 2-27 |
| 2.4.1.4 | LA75 Printing Erroneous Characters.....         | 2-27 |
| 2.5     | Service Diagnostics .....                       | 2-27 |
| 2.5.1   | System Errors Versus Diagnostic Errors .....    | 2-28 |
| 2.5.2   | Previously Detected Error .....                 | 2-28 |
| 2.5.3   | Main Diagnostic Menu .....                      | 2-29 |
| 2.5.4   | Selecting a Mode from Main Diagnostic Menu..... | 2-33 |
| 2.5.5   | System Test Mode .....                          | 2-33 |
| 2.5.5.1 | Test Option Menu .....                          | 2-34 |
| 2.5.5.2 | System Test Requirements .....                  | 2-37 |
| 2.5.5.3 | System Test Execution.....                      | 2-42 |
| 2.5.6   | Individual Tests .....                          | 2-44 |
| 2.5.7   | New Diagnostic Installation .....               | 2-47 |
| 2.5.8   | Error Log Mode.....                             | 2-48 |

## Chapter 3 ThinWire Ethernet

|       |   |      |
|-------|---|------|
| 3.1   | Introduction .....                                      | 3-1  |
| 3.2   | ThinWire Network Hardware Components .....              | 3-1  |
| 3.2.1 | ThinWire Network Terms .....                            | 3-3  |
| 3.3   | ThinWire Network Troubleshooting.....                   | 3-6  |
| 3.4   | Installation Guidelines.....                            | 3-7  |
| 3.5   | Installation Procedures .....                           | 3-9  |
| 3.5.1 | ThinWire Network and VAXmate Server .....               | 3-9  |
| 3.5.2 | ThinWire Network with MicroVAX II Computer Server ..... | 3-11 |

|  |      |
|--|------|
| 3.5.3 Adding a Workstation to End of ThinWire Segment .....                  | 3-13 |
| 3.5.4 Adding a VAXmate Workstation to Middle of an Existing<br>Segment ..... | 3-14 |
| 3.6 ThinWire Local Area Network (LAN) Example .....                          | 3-15 |
| 3.7 ThinWire Network Map and Worksheet .....                                 | 3-16 |

## Chapter 4 Monitor Adjustments

|  |      |
|--|------|
| 4.1 Introduction .....                       | 4-1  |
| 4.2 Brightness and Contrast Adjustment ..... | 4-2  |
| 4.3 Internal Monitor Adjustments .....       | 4-3  |
| 4.3.1 Horizontal Hold .....                  | 4-5  |
| 4.3.2 Cutoff .....                           | 4-6  |
| 4.3.3 Width Coil .....                       | 4-7  |
| 4.3.4 Height – 400 Line Mode .....           | 4-8  |
| 4.3.5 Centering Rings .....                  | 4-9  |
| 4.3.6 Rotation .....                         | 4-11 |
| 4.3.7 Video Compensation .....               | 4-12 |
| 4.3.8 Height – 250 Line Mode .....           | 4-13 |
| 4.3.9 Focus .....                            | 4-13 |

## Chapter 5 FRU Replacement

|   |      |
|---|------|
| 5.1 Introduction .....  | 5-1  |
| 5.2 Before You Replace Any FRUs .....                         | 5-3  |
| 5.3 Replacing FRUs .....                                      | 5-4  |
| 5.3.1 Turning Off Power and Unplugging External Cables .....  | 5-4  |
| 5.3.2 Separating the Expansion Box from the System Unit ..... | 5-5  |
| 5.3.3 Fuse Replacement .....                                  | 5-6  |
| 5.3.4 Opening the System Unit Back Door .....                 | 5-7  |
| 5.3.5 System Unit Back Door Removal .....                     | 5-8  |
| 5.3.6 System Unit Cover Removal .....                         | 5-11 |
| 5.3.7 2 Mbyte Memory Replacement .....                        | 5-13 |
| 5.3.8 Modem Board Replacement .....                           | 5-14 |
| 5.3.9 Math Coprocessor (80287) Replacement .....              | 5-16 |
| 5.3.10 Speaker Replacement .....                              | 5-18 |
| 5.3.11 Monitor Board Removal .....                            | 5-20 |
| 5.3.12 CRT Handling Precautions .....                         | 5-25 |
| 5.3.13 CRT Assembly Removal .....                             | 5-26 |
| 5.3.14 CRT Assembly Installation .....                        | 5-31 |
| 5.3.15 Diskette Drive Removal .....                           | 5-33 |
| 5.3.16 Diskette Drive Installation .....                      | 5-36 |



5.3.17 CPU Board Removal.....5-37

5.3.18 CPU Board Installation.....5-42

5.3.19 Power LED Removal.....5-44

5.3.20 Power LED Installation.....5-45

5.3.21 I/O-Video Board Removal .....5-46

5.3.22 I/O-Video Board Installation .....5-49

5.3.23 Power Supply Board Replacement.....5-50

5.3.24 Expansion Box Cover Removal .....5-50

5.3.25 Hard Disk Drive Removal .....5-52

5.3.26 Hard Disk Drive Removal with Fan Present.....5-54

5.3.27 Hard Disk Drive Base Plate Removal.....5-56

5.3.28 Read/Write Board Removal from the Hard Disk .....5-57

5.3.29 Read/Write Board Installation .....5-59

5.3.30 Removing Skid Plate from New Hard Disk .....5-61

5.3.31 Hard Disk Drive Installation.....5-62

5.3.32 Gaining Access to the Expansion Box Card Cage .....5-64

5.3.33 Hard Disk Controller Replacement .....5-65

5.3.34 Option Replacement in the Expansion Box.....5-66

5.3.35 Option Backplane Replacement.....5-67

5.3.36 Expansion Box Fan Replacement .....5-68

5.3.37 Expansion Box Power Connector and Bridge Replacement.....5-70

5.3.38 Expansion Box Power Regulator Replacement.....5-72

**Appendix A Part Numbers.....A-1**

**Appendix B Test Descriptions.....B-1**

B.1 Introduction.....B-1

**Appendix C Error Numbers.....C-1**

**Tables**

Table 1-1 Electrical Description .....1-12

Table 1-2 Expansion Box Power Consumption (Maximum) .....1-13

Table 2-1 LED Function.....2-5

Table 2-2 Symptoms .....2-11

Table 4-1 Adjustments, Patterns, and Control Locations.....4-3

Table 5-1 FRUs and Removal/Replacement Procedures Paragraph  
Numbers.....5-2



|           |  |      |
|-----------|--|------|
| Table A-1 | VAXmate Workstation Recommended Spares ..... | A-2  |
| Table A-2 | Printer Components .....                     | A-4  |
| Table A-3 | Base System .....                            | A-4  |
| Table A-4 | Networking Components .....                  | A-5  |
| Table A-5 | Country Specific Components.....             | A-6  |
| Table C-1 | ROM Diagnostics Error Numbers .....          | C-1  |
| Table C-2 | Service Diagnostics Error Numbers.....       | C-4  |
| Table C-3 | Install New Diagnostics Error Messages ..... | C-21 |
| Table C-4 | System Error Messages.....                   | C-22 |

## Figures

|             |   |      |
|-------------|---|------|
| Figure 1-1  | VAXmate Workstation .....                                       | 1-2  |
| Figure 1-2  | VAXmate Workstation Block Diagram .....                         | 1-5  |
| Figure 1-3  | I/O-Video Board Block Diagram.....                              | 1-7  |
| Figure 2-1  | LED Locations .....   | 2-4  |
| Figure 2-2  | ROM Diagnostic Test Sequence (Sheet 1 of 3) .....               | 2-7  |
| Figure 2-2  | ROM Diagnostic Test Sequence (Sheet 2 of 3) .....               | 2-8  |
| Figure 2-2  | ROM Diagnostic Test Sequence (Sheet 3 of 3) .....               | 2-9  |
| Figure 2-3  | CPU Board Jumpers .....   | 2-16 |
| Figure 2-4  | Inserting the Diskette .....                                    | 2-23 |
| Figure 2-5  | Extended Self-Test Keys .....                                   | 2-23 |
| Figure 2-6  | Sample Configuration Display .....                              | 2-24 |
| Figure 2-7  | Restarting Service Diagnostics.....                             | 2-28 |
| Figure 2-8  | ROM Diagnostic Error.....                                       | 2-29 |
| Figure 2-9  | Main Diagnostic Menu .....                                      | 2-30 |
| Figure 2-10 | Service Diagnostics Mode Selection Keys.....                    | 2-33 |
| Figure 2-11 | Test Option Menu.....   | 2-34 |
| Figure 2-12 | Prompt on Error .....   | 2-35 |
| Figure 2-13 | Loop on Error.....  | 2-36 |
| Figure 2-14 | System Test Requirements.....                                   | 2-37 |
| Figure 2-15 | Assembling the Network Port Loopback Connector .....            | 2-38 |
| Figure 2-16 | Disconnecting from the Network .....                            | 2-39 |
| Figure 2-17 | Disconnecting Mouse, Printer, and<br>Communications Cables..... | 2-40 |
| Figure 2-18 | Installing Loopback Connectors .....                            | 2-41 |
| Figure 2-19 | System Test Execution .....                                     | 2-43 |
| Figure 2-20 | Individual Test Menu .....                                      | 2-45 |
| Figure 2-21 | Individual Test Execution .....                                 | 2-46 |
| Figure 2-22 | Sample Error Log.....   | 2-49 |



|             |   |      |
|-------------|---|------|
| Figure 3-1  | Cable Components .....  | 3-2  |
| Figure 3-2  | Two Sample ThinWire Networks .....                                    | 3-2  |
| Figure 3-3  | DIGITAL Faceplate .....   | 3-5  |
| Figure 3-4  | Correct and Incorrect ThinWire Segment Installation .....             | 3-8  |
| Figure 3-5  | ThinWire Network with a VAXmate Server .....                          | 3-10 |
| Figure 3-6  | ThinWire Network with MicroVAX II Server .....                        | 3-11 |
| Figure 3-7  | Adding a VAXmate Workstation to End of Existing Segment .....         | 3-13 |
| Figure 3-8  | Adding a VAXmate Workstation to Middle of an Existing Segment .....   | 3-14 |
| Figure 3-9  | Sample ThinWire LAN .....   | 3-15 |
| Figure 4-1  | Brightness and Contrast Controls .....                                | 4-2  |
| Figure 4-2  | Monitor Board Controls .....  | 4-4  |
| Figure 4-3  | Horizontal Hold .....   | 4-5  |
| Figure 4-4  | Cutoff Adjustment .....   | 4-6  |
| Figure 4-5  | Width Measurement .....   | 4-7  |
| Figure 4-6  | Height Measurement .....  | 4-8  |
| Figure 4-7  | Centering Measurement .....   | 4-9  |
| Figure 4-8  | Yoke Centering Rings .....  | 4-10 |
| Figure 4-9  | Rotation Measurement .....  | 4-11 |
| Figure 5-1  | Cable Locations .....   | 5-4  |
| Figure 5-2  | Separating the Expansion Box from the System Unit .....               | 5-5  |
| Figure 5-3  | Fuse Location .....   | 5-6  |
| Figure 5-4  | Opening the Back Door .....   | 5-7  |
| Figure 5-5  | Removing the Back Door Screws .....                                   | 5-8  |
| Figure 5-6  | Swinging the Door Up .....  | 5-9  |
| Figure 5-7  | Releasing the Links to Remove the Door .....                          | 5-10 |
| Figure 5-8  | Removing the Cover .....  | 5-11 |
| Figure 5-9  | Board Locations .....   | 5-12 |
| Figure 5-10 | Removing the 2 Mbyte Memory Board .....                               | 5-13 |
| Figure 5-11 | Removing the Modem Board .....  | 5-14 |
| Figure 5-12 | Modem Board Jumper Locations .....                                    | 5-15 |
| Figure 5-13 | Installing the 80287 Coprocessor .....                                | 5-16 |
| Figure 5-14 | Special Option Installed Label .....                                  | 5-17 |
| Figure 5-15 | Removing the Speaker .....  | 5-19 |
| Figure 5-16 | Webbed Shield .....   | 5-20 |
| Figure 5-17 | Discharging the Anode .....   | 5-21 |
| Figure 5-18 | Removing the Anode Connector .....                                    | 5-22 |
| Figure 5-19 | Monitor Board Screw .....   | 5-23 |
| Figure 5-20 | Unplugging Cables and Pushing the Anode Wire Through the Shield ..... | 5-24 |

Figure 5-21 Removing Connectors, Lug, Spring, and Braided Ground Straps .....5-27

Figure 5-22 Disconnecting Power LED Cable .....5-28

Figure 5-23 Removing the Four Bezel Screws and the Top Screw .....5-29

Figure 5-24 Removing the CRT Assembly.....5-30

Figure 5-25 CRT Installation .....5-31

Figure 5-26 Removing Cables, Screws, and Heat Shield .....5-33

Figure 5-27 Sliding Drive and Housing Out of the System Unit .....5-34

Figure 5-28 Sliding the Diskette Drive from Its Housing .....5-35

Figure 5-29 Jumper FG Location (Diskette Drive).....5-37

Figure 5-30 Removing LED Cable and Plastic Dress Bezel .....5-38

Figure 5-31 Power Supply Ground Wire .....5-39

Figure 5-32 Lifting Out Power Supply, I/O-Video, and CPU Boards.....5-40

Figure 5-33 CPU Board Components and Jumpers .....5-41

Figure 5-34 Removing the Power On LED Assembly .....5-44

Figure 5-35 Replacing the Power LED Assembly .....5-45

Figure 5-36 Mounting Screws .....5-46

Figure 5-37 Removing the I/O-Video Board Bezel .....5-47

Figure 5-38 Removing the I/O-Video Board Shield.....5-48

Figure 5-39 Removing the Expansion Box Cover .....5-51

Figure 5-40 Hard Disk Drive Cables and Screws .....5-53

Figure 5-41 Hard Disk Drive Removal with Fan Present .....5-54

Figure 5-42 Removing Base Plate .....5-56

Figure 5-43 Read/Write Board Screws and Washers.....5-57

Figure 5-44 Removing Connectors 1 and 2 .....5-58

Figure 5-45 Removing Connector 3 .....5-59

Figure 5-46 Jumper Setting for Drive Select.....5-60

Figure 5-47 Removing Skid Plate .....5-61

Figure 5-48 Replacing Base Plate .....5-62

Figure 5-49 Hard Disk Drive Installation .....5-63

Figure 5-50 Gaining Access to the Card Cage .....5-64

Figure 5-51 Removing Hard Disk Controller .....5-65

Figure 5-52 Removing Option Board.....5-66

Figure 5-53 Removing Backplane.....5-67

Figure 5-54 Removing Fan.....5-69

Figure 5-55 Removing Bridge and Power Connector.....5-71

Figure 5-56 Power Regulator Board .....5-73



# *Introduction*

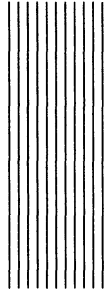

The *VAXmate Service Guide* is packaged in the VAXmate Maintenance Kit and is designed to help you diagnose and repair the VAXmate Workstation. This guide also describes the basic concepts of connecting the VAXmate to a network, and troubleshooting a part of the VAXmate network.

***WARNING***

The procedures in this guide are for DIGITAL service technicians only.

By using this guide, along with the other items in the Maintenance Kit, you can isolate problems to the field replaceable unit (FRU).





*Introduction*

Make sure your Maintenance Kit contains these items.

LOOPBACK CONNECTORS AND TERMINATORS

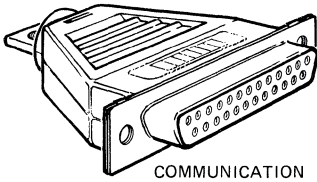

COMMUNICATION

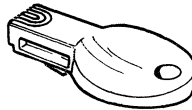

PRINTER



MOUSE

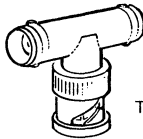

T-CONNECTOR

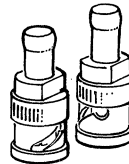

TWO 50-OHM TERMINATORS

DISKETTES

FORMATTED LOW DENSITY

LOW-DENSITY

DIAGNOSTIC

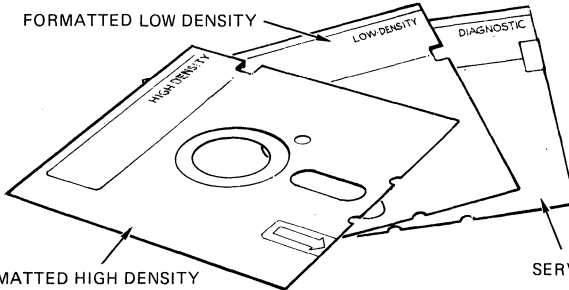

FORMATTED HIGH DENSITY

SERVICE DIAGNOSTICS

SERVICE GUIDE AND 3-RING BINDER

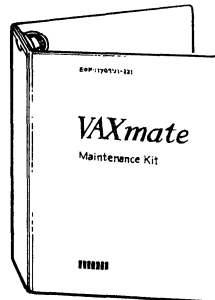

LJ-0896

**Maintenance Kit Items**



The part numbers for the VAXmate Maintenance Kit items are as follows.

| <b>Description of Item</b>             | <b>Part/Kit No.</b> |
|--|---------------------|
| VAXmate Maintenance Kit                | 00-Z6002-M7         |
| Communications loopback connector      | 12-15536-06         |
| Printer loopback connector             | 12-25083-01         |
| Mouse loopback connector               | 12-25628-01         |
| T-connector                            | 12-25534-01         |
| BNC terminator (50-ohm) (two)          | 12-25535-01         |
| Formatted high density diskette (RX33) | BN-HU11A-BK         |
| Formatted Low Density Diskette (RX31)  | BL-N402A-BK         |
| VAXmate Service Diagnostic diskette    | BN-HD93x-Y7         |
| VAXmate Service Guide                  | EK-P500B-SV         |
| DEPCA Service Diagnostic diskette*     | BI-KL23xYH          |
| DEPCA Service Guide*                   | EK-DEPCA-SV         |
| DECNA loopback connector*              | 12-22196-01         |

In addition to the Maintenance Kit you may also need these items, depending on the type of repair. Ask your branch to order them for you.

| <b>Description of Item</b> | <b>Part No.</b> | <b>Type of Repair</b>            |
|----------------------------|-----------------|----------------------------------|
| Ohmmeter (times 1 scale)   | N/A             | Network testing                  |
| Anode discharge tool       | 29-24717        | CRT or monitor board replacement |
| Metric tape measure        | 29-25342        | Video alignment                  |

This guide does not help you diagnose problems caused by options purchased from vendors other than DIGITAL.

---

\*. These items are for servicing Digital's network adapter (DEPCA) for IBM personal computer.



The chapters and appendices in this guide are as follows.

Chapter 1, Overview, describes the VAXmate computer.

Chapter 2, Troubleshooting the VAXmate Workstation, describes the testing procedure and how to isolate problems to the failing field replaceable unit (FRU).

Chapter 3, ThinWire Ethernet, describes ThinWire Ethernet terms, gives installation examples, and gives procedures for troubleshooting part of the VAXmate ThinWire network.

Chapter 4, Monitor Adjustments, describes how to adjust the screen display after replacing of the CRT and/or the monitor board.

Chapter 5, FRU Replacement describes how to remove faulty FRUs and replace them with new FRUs.

Appendix A, Part Numbers lists the recommended spares for the VAXmate workstation. It also lists networking and printer components, and order numbers.

Appendix B, Test Descriptions, describes the tests in the Service Diagnostics. Use this as a reference to Chapters 2, 3, and 4.

Appendix C, Error Numbers lists all error numbers and possible messages that can occur through diagnostic testing. Also listed with the error numbers are the corresponding FRUs (Field Replaceable Units).

For more information on the VAXmate computer and information about networking, refer to the documents in Table I-1.

**Table I-1 Related Documents**

| <b>Document</b>   | <b>Part Number</b> |
|---|--------------------|
| VAXmate Workstation   |                    |
| VAXmate System Handbook   | AA-JC47A-TH        |
| VAXmate System Administrator's Guide, including:<br>—VAXmate User's Guide, Volume 1 and 2         | QLA93-GZ           |
| VAXmate Technical Description Manual  | EK-PC500-TD        |
| VAXmate Technical Reference Manual, Volume 1 and 2<br>(programming reference manuals and binders) | Q6ZCS-GZ           |
| VAXmate Illustrated Parts Breakdown Manual  | EK-PC500-IP        |
| Options   |                    |
| VAXmate Expansion Box Installation Guide (Card)   | EK-RCD31-IN        |
| VAXmate Expansion Box Internal Option Installation Guide (Card)                                   | EK-BA500-IN        |
| VAXmate Expansion Box Installation Guide and Owner's Manual                                       | EK-RCD31-OM        |
| VAXmate Integral Modem User's Guide   | EK-P50XM-UG        |
| PC50X-MA Modem Installation Guide   | EK-P50XM-IN        |
| PC50X-AA Memory Installation Guide  | EK-P50XA-IN        |
| 80287 Coprocessor Installation Guide  | EK-FP287-IN        |
| VAXmate PC50X-MA Integral Modem User's Guide  | EK-P50XM-UG        |
| Installing and Using the LA75 Companion Printer   | EK-OLA75-UG        |
| Networks  |                    |
| DECconnect System Requirements Evaluation Workbook  | EK-DECSY-EG        |
| DECconnect System Planning and Configuration Guide  | EK-DECSY-CG        |
| DECconnect System Installation and Verification Guide   | EK-DECSY-VG        |
| DESTA Installation Card   | EK-DESTA-IN        |
| DESTA Technical Description   | EK-DESTA-TM        |
| ThinWire Ethernet Cable Connector Installation Guide (Card)                                       | EK-CABLE-IN        |
| Ethernet Installation Guide, Volume 1   | EK-ETHER-IN        |
| Vendor Equipment Services   |                    |
| VES Mini Reference Guide, Volume 1  | EK-MINI1-RG        |
| VES Mini Reference Guide, Volume 2  | EK-MINI2-RG        |
| VES Mini Reference Guide, Volume 3  | EK-MINI3-RG        |
| VES Mini Reference Guide, Volume 4  | EK-MINI4-RG        |
| VES Mini Reference Guide, Volume 5  | EK-MINI5-RG        |



# *Chapter 1*

## *Overview*

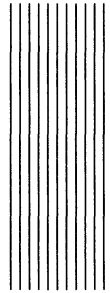

### **1.1 Introduction**

The VAXmate Workstation (Figure 1-1) is a desktop computer. It can be used as a standalone personal computer or, more often, as a node on a network to a VAX, MicroVAX II computer, or even to another VAXmate that has network server software. The VAXmate computer is compatible with industry-standard\* personal computers and runs both industry-standard\* applications and applications designed by DIGITAL.

As a node on the Personal Computing System Architecture (PCSA) network, the VAXmate computer system is the user's interface into the applications and services that the PCSA family of products provides. As part of a network, the VAXmate computer communicates with other computers on the network, as well as shares the various resources and services offered by DIGITAL computers and servers.

---

\* The computer industry recognizes two open architectures as industry standards. The first is the IBM-PC-AT bus structure. The second is the MicroSoft disk operating system (MS-DOS). The term industry-standard refers to compatibility with these architectures. To support MS-DOS requires a defined set of ROM-BIOS (basic I/O system) services, which the VAXmate workstation offers.

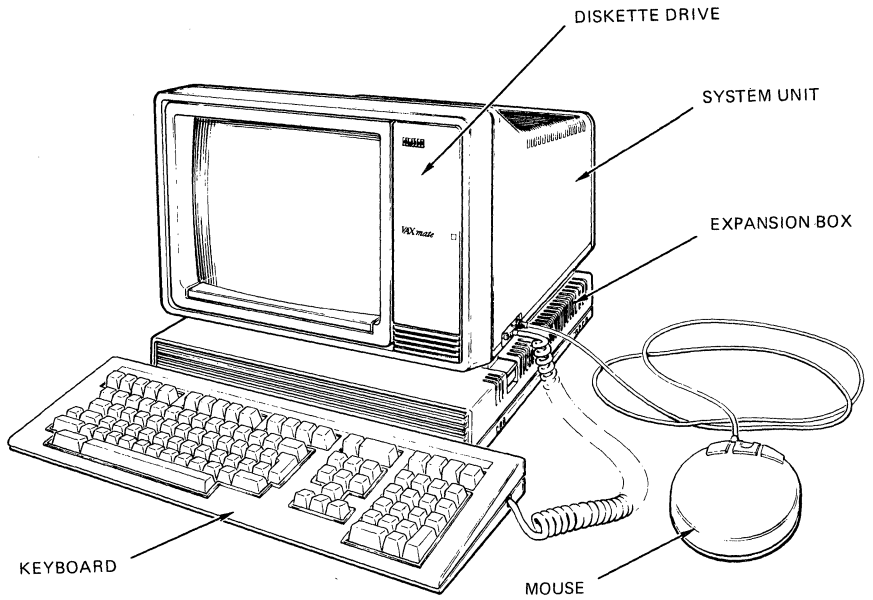

LJ-0811A1

**Figure 1-1 VAXmate Workstation**

## 1.2 VAXmate Workstation Components

The VAXmate workstation consists of the following items. An asterisk (\*) indicates that the component is a field replaceable unit (FRU).

System Unit including:

- Power indicator light\*
- Monitor (amber or green screen)\*
- Monitor Board\*
- I/O-Video Board\* containing:
  - Video controller
  - Diskette controller
  - Communications port
  - Printer port
  - Port for integral modem option
  - DIGITAL ThinWire Ethernet interface
- CPU Board\* containing:
  - Memory (1 Mbyte)
  - 80286 processor
  - Keyboard port
  - Mouse port
  - Socket for 80287 coprocessor option
  - Connector for memory option board
- Power Supply (120 V or 240 V)\*
- Diskette drive (1.2 Mbytes)\*

Keyboard (LK250)\*

Mouse\*

Speaker\*

LAN (Local Area Network) assembly\* (ThinWire Ethernet) including:

- ThinWire Ethernet Cable
- One T-connector
- One terminator (50-ohm)

---

\* Indicates that the component is a field replaceable unit (FRU).





Options for the system unit include the following items.

- Integral modem board with 8-pin modular (telephone compatible) connectors
- Memory (2 Mbyte memory board)\*
- Numeric processor extension – 80287 chip\*
- Dot-matrix companion printer – LA75
- Laser printer – LN03 Plus
- Expansion box\*

The Expansion Box option includes the following items.

- Power regulator\*
- Lithium battery backup for event timer\*
- Two option slots for industry-standard options\*  
(Each slot accepts options that require 9.5 watts/slot maximum, a CPU clock frequency of 8 megacycles, and is compatible with the industry-standard 8-bit bus and 16-bit bus.)
- Hard disk drive\*
- Hard disk controller\*

Networking options include the following items.

- DIGITAL Ethernet Multiport Repeater (DEMPR)
- DIGITAL Ethernet Station Adapter (DESTA)

Figure 1-2 is a block diagram of the VAXmate workstation. If you need more technical information, refer to the *VAXmate Technical Description Manual* (EK-PC500-TD).

---

\* Indicates that the component is a field replaceable unit (FRU).

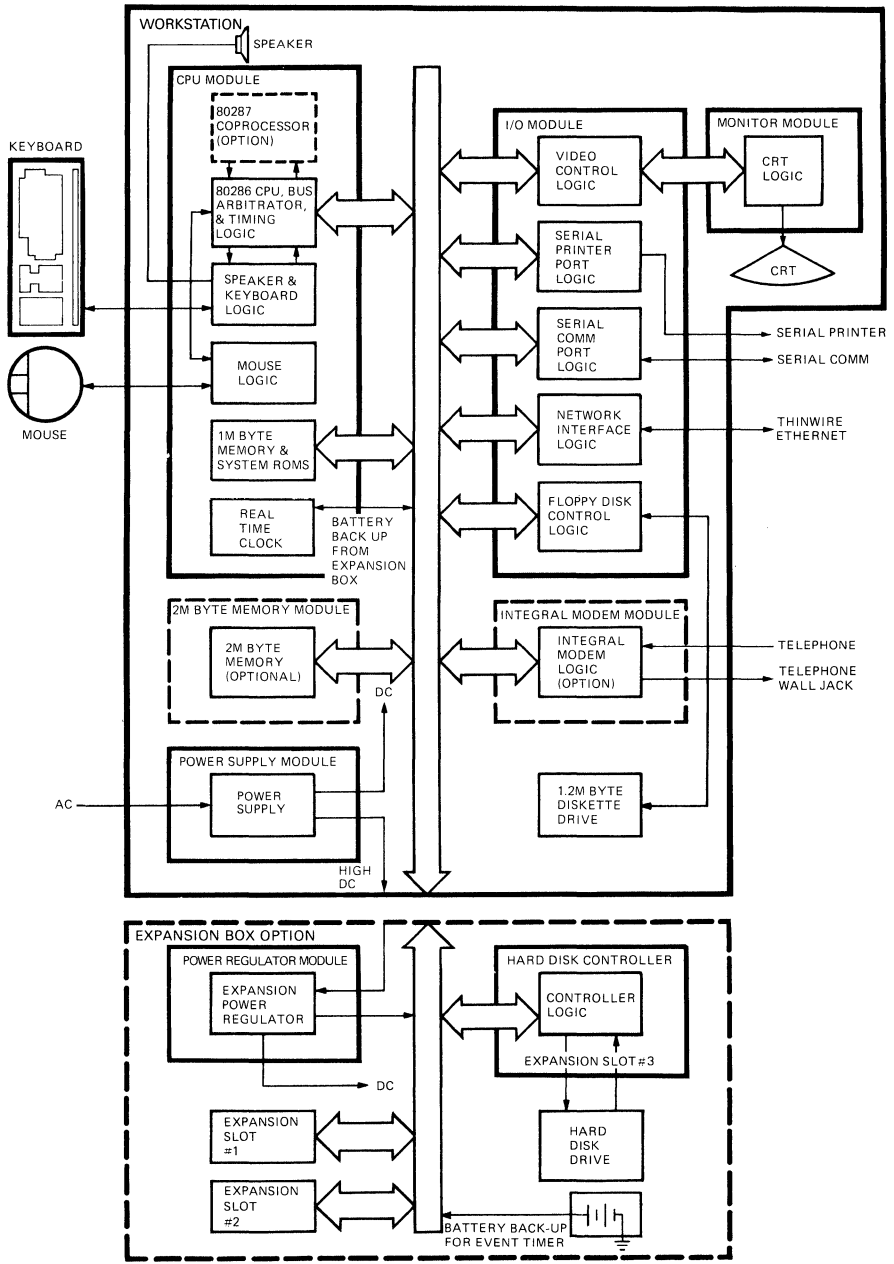

LJ-1027

Figure 1-2 VAXmate Workstation Block Diagram



### **1.2.1 Monitor (Amber or Green Screen)**

The monitor is a 14 inch diagonal display cathode ray tube (CRT) and generates  $800 \times 250$  or  $640 \times 400$  raster. The CRT displays a video image of up to 16 shades of gray. Through use of a control signal from the video controller, the CRT can switch to 250 scan or 400 scan operation.

The monitor can be tilted up or down to provide the user with a range of viewing angles. While pressing the bar at the base of the screen, press inward at the top or at the bottom of the monitor bezel.

### **1.2.2 I/O-Video Board**

The I/O-video board accepts the 16-bit bus signals generated by the CPU board. The I/O-video board provides all the non-optional I/O, peripheral interface, and video display control functions of the VAXmate workstation system.

Figure 1-3 shows a block diagram of the I/O-video board. The board contains:

- Video subsystem
- Serial communications port
- Serial printer port
- ThinWire Ethernet interface
- Connection for integral modem and
- Diskette controller logic.

#### **1.2.2.1 Communications Port**

This port, a 25-pin connector, is on the rear bezel of the VAXmate system unit. This connector is functionally compatible with RS-232-C and electrically compatible with RS-423, configured as DTE (Data Terminal Equipment). The communications port has a DEC Std 52 compliant serial communications interface with modem control.

#### **1.2.2.2 Printer Port**

This port has a 9-pin connector, located on the rear bezel of the VAXmate system unit. The serial printer port can communicate with an ASCII protocol printer. The port supports two modem control lines.

Figure 1-3 I/O-Video Board Block Diagram

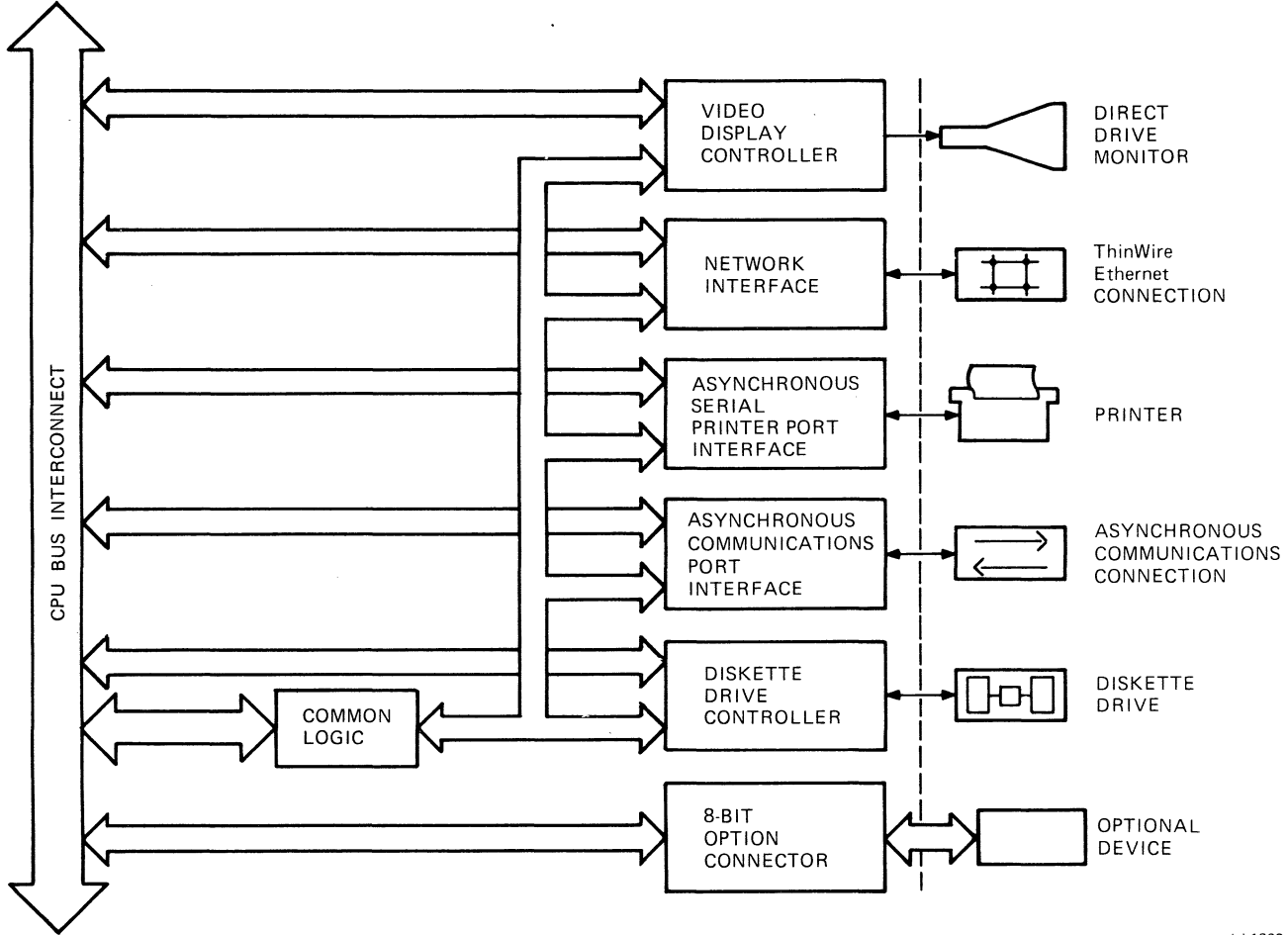



### **1.2.3 CPU Board**

The CPU/Memory board has an 8 MHz, 80286 processor with its associated logic (DMA control, interrupt control, bus control, event timer, command/status registers, and so on). An optional 5.33 MHz 80287 coprocessor can be added to enhance the CPU by providing fast processing of math functions on floating point and other data types.

The memory part of the board has a one Mbyte dynamic memory with byte parity. An optional DIGITAL two Mbyte memory board can be added to provide a total of three Mbytes of usable memory. By adding industry-standard expansion boards in the expansion box, the total memory can be extended to 15 Mbytes. In addition, the CPU board has a 32 byte Ethernet address ROM, which stores the unique xx-byte node number.

The old CPU board (54-16847) and the new CPU board (54-17187) basically function the same, but the new board solves the EGA/network conflict. Do not install the new CPU board unless the mechanical parts in the PC500-UA grounding kit are also installed. The PC500-UA kit includes the new CPU board and all the necessary grounding hardware.

See Appendix D for a detailed block diagram of the CPU board.

### **1.2.4 Power Supply**

The power supply delivers all dc power required by the VAXmate workstation. The VAXmate workstation comes with either a 120 V or 240 V ac power supply. An appropriate power cord for each country is available.

### **1.2.5 RX33 1.2 Mbyte Diskette Drive**

The RX33 is a 5<sup>1</sup>/<sub>4</sub> inch, double-sided, dual-speed, half-height, 96 tracks per inch (tpi) diskette drive. It has full RX50 single-sided, read/write compatibility and industry-standard 1.2 megabyte compatibility.



### 1.2.6 Keyboard

The LK250 keyboard is compatible with DIGITAL and industry-standard computers when the appropriate cable is used. The keycap labeling is as follows.

- Black labels are for standard DIGITAL keyboard keys.
- Blue labels are for special functions with industry-standard applications.
- Gold labels are for special functions with DIGITAL's WPS-Plus word processing software.

There are two different part numbers for the keyboard. (See Appendix A, Part Numbers.) The industry-standard keyboard uses a different cable than the DIGITAL keyboard.

### 1.2.7 Mouse

The three-button mouse is a pointing device that provides X-Y coordinate output data. It has a resolution of 0.127 mm (0.005 in) for use in controlling various functions of the VAXmate workstation.

### 1.2.8 ThinWire Ethernet Cable

The ThinWire Ethernet is a second-generation cabling standard that provides 10 Mbits/second transfer rate performance and enables configuration of low-cost, high-bandwidth local area networks. Customers can connect their VAXmate workstations with small sections of cable and simple connectors; no tools are needed. ThinWire Ethernet can be used to link desktop computers, such as VAXmate workstations to a MicroVAX II computer or any networking devices.

### 1.2.9 Options

The following options are available.

- 2 Mbyte memory
- 80287 coprocessor
- Expansion box
- Hard disk drive and controller board
- Integral modem board for North America
- LA75 printer
- LN03 PLUS printer

### **1.2.9.1 Two-Mbyte Memory Board**

This option board mounts in a connector on the back of the CPU board and can be installed by the customer by simply opening the rear door. The option memory board has dynamic memory, memory control circuitry, and parity generation/checking circuitry.

### **1.2.9.2 80287 Coprocessor**

The coprocessor is a chip that plugs into the CPU board. It must not be installed by the customer or the warranty is voided. Installation by Field Service is included in the list price (MLP) of this option. The coprocessor speeds up arithmetic instructions for a variety of numeric data processing.

### **1.2.9.3 Expansion Box**

The expansion box connects to the bottom of the system unit. The expansion box contains the hard disk drive and hard disk drive controller. It also contains the expansion box power supply regulator, battery back-up for the event timer and two slots for industry-standard hardware options. The RD31 has 20 Mbytes of storage on the drive; the RD32 has 40 Mbytes of storage.

### **1.2.9.4 Integral Modem Board for North America**

The modem board is customer-installable and plugs into connectors on the I/O-video board. The modem has two modular telephone line compatible connectors that protrude through the rear panel of the VAXmate workstation. The connector uses an 8-pin, keyed modular housing for an RC11C jack (or CA11 jack in Canada).

### **1.2.9.5 LA75 Printer**

The printer is a dot-matrix “companion” printer for the VAXmate workstation. It is DIGITAL’s replacement for the LA50 printer. The LA75 offers the ability to insert single sheets of paper without removing the continuous form paper, and a separate feed for envelope addressing.

The LA75 uses DIGITAL printer protocols, as well as industry-standard protocols, for text and bit map graphics. It is shipped with the same default settings as the VAXmate workstation. These settings are: 4800 baud rate, 8 data bits no parity. The LA75 returns an LA50 ID upon interrogation by the CPU.



The LA75 cable part number is BC16E-xx. An adapter may be required for a host computer other than the VAXmate workstation. See the printer documentation.

#### **1.2.9.6 LN03 Plus Printer**

This letter-quality laser printer operates at 8 pages per minute. Like the LA75, the LN03 uses DIGITAL printer protocols. With the addition of a plug-in ROM cartridge, the LN03 provides industry-standard compatibility. The LN03 printer uses a BC22D cable to connect to a VAXmate.

#### **1.2.10 DIGITAL ThinWire Ethernet Multiport Repeater (DEMPR)**

The DEMPR connects up to eight thin coaxial cable segments, each up to 185 meters long. Up to 29 workstations can be connected on each segment for a maximum of 232 workstations.

The DEMPR can also stand alone to link desktop systems in several offices to a resource-sharing network. The DEMPR can be mounted on a wall or table, and is also rack-mountable.

#### **1.2.11 DIGITAL ThinWire Ethernet Station Adapter (DESTA)**

The DESTA is a compact Ethernet transceiver that adapts standard Ethernet products for connection to ThinWire Ethernet cable. It has a 15-pin transceiver cable connector at one end to attach to the standard Ethernet devices, and a BNC connector at the other end to connect to the ThinWire Ethernet cable.

### **1.3 Environmental and Electrical Description**

The VAXmate workstation is convection cooled, and therefore, generates no noise in an office environment. The system package housing is constructed of plastic with inner conductive coatings to provide EMC/RFI shielding. The VAXmate workstation is designed and tested to meet DEC Std 102 requirements for a class A (computer room) environment. The VAXmate workstation also complies with the following environmental and safety standards.





- DEC Std 103 – Electromagnetic Compatibility (EMC) Hardware Design Requirements. The VAXmate workstation meets FCC class “A” Level, which makes it unsuitable for home use.
- DEC Std 119 – Digital Product Safety
- DEC Std 122 – AC Power Line Standard

Table 1-1 lists the power consumption of the system unit.

**Table 1-1 System Unit Power Consumption (Maximum Amps and Power)**

| Component            | +5.1V         | +12.1V        | -12.0V        | +28.0V        | -9.0V         | Watts  |
|----------------------|---------------|---------------|---------------|---------------|---------------|--------|
| CPU board (max)      | 4.486<br>Amps | 0.013<br>Amps | 0.013<br>Amps | 0.000<br>Amps | 0.000<br>Amps | 23.192 |
| I/O-video board      | 3.100         | 0.060         | 0.039         | 0.000         | 0.200         | 18.806 |
| Monitor board (max)  | 0.200         | 0.250         | 0.250         | 0.550         | 0.000         | 22.445 |
| RX33                 |               |               |               |               |               |        |
| Start-up<br>(400 ms) | 0.630         | 1.000         | 0.000         | 0.000         | 0.000         | 15.313 |
| Read/write           | 0.550         | 0.600         | 0.000         | 0.000         | 0.000         | 10.065 |
| 2 Mbyte memory       | 0.600         | 0.000         | 0.000         | 0.000         | 0.000         | 3.060  |
| Integral modem       | 0.750         | 0.040         | 0.030         | 0.000         | 0.000         | 4.669  |
| LK250 (external)     | 0.220         | 0.000         | 0.000         | 0.000         | 0.000         | 1.122  |
| Mouse (external)     | 0.250         | 0.000         | 0.000         | 0.000         | 0.000         | 1.275  |
| TOTAL                |               |               |               |               |               |        |
| steady-state         | 10.156        | 0.963         | 0.332         | 0.550         | 0.200         | 84.633 |
| peak                 | 10.236        | 1.363         | 0.332         | 0.550         | 0.200         | 89.881 |

The VAXmate workstation power supply and the expansion box power regulator provide a total of 28.5 watts of power to the expansion box card cage (9.5 watts per option slot). The hard disk controller occupies the top option slot (when installed). A total of 19 watts is available for any industry-standard options in the remaining two slots. Each option slot accepts options that use an 8-bit and/or 16-bit industry-standard bus and a clock frequency of 8 Mhz.

Table 1-2 lists power consumption in the expansion box.

**Table 1-2 Expansion Box Power Consumption (Maximum)**

| Component            | +5.1V | +12.1V | -12.0V | -5.0V | Fan  | Watts |
|----------------------|-------|--------|--------|-------|------|-------|
| RD31 (max)           | Amps  | Amps   | Amps   | Amps  | Amps | 38.80 |
| Start-up<br>(20 sec) | 1.20  | 2.60   | 0.00   | 0.00  |      |       |
| Operating:           |       |        |        |       |      |       |
| idle                 | 0.60  | 0.90   | 0.00   | 0.00  |      | 15.50 |
| random seek          | 0.60  | 1.10   | 0.00   | 0.00  |      | 17.50 |
| RD32 (max)           |       |        |        |       |      |       |
| Startup<br>(20 sec)  | 1.30  | 2.00   | 0.00   | 0.00  |      | 32.00 |
| Operating:           |       |        |        |       |      |       |
| idle                 | 1.20  | 0.51   | 0.00   | 0.00  |      | 12.73 |
| random seek          | 1.30  | 1.80   | 0.00   | 0.00  |      | 29.50 |
| RCD31/32 controller  | 1.00  | 0.001  | 0.00   | 0.00  |      | 5.26  |
| Option-1             | 1.30  | 0.10   | 0.10   | 0.10  |      | 9.54  |
| Option-2             | 1.30  | 0.10   | 0.10   | 0.10  |      | 9.54  |
| TOTAL                |       |        |        |       |      |       |
| RCD31-EA, -EC        |       |        |        |       |      |       |
| steady-state         | 4.30  | 1.30   | 0.20   | 0.20  |      | 41.44 |
| peak                 | 4.80  | 2.80   | 0.20   | 0.20  |      | 63.14 |
| RCD31-FA, -FC        |       |        |        |       |      |       |
| steady-state         | 4.30  | 1.30   | 0.20   | 0.20  | 0.25 | 44.44 |
| peak                 | 4.80  | 2.80   | 0.20   | 0.20  | 0.25 | 66.14 |
| RCD32-FA, -FC        |       |        |        |       |      |       |
| steady-state         | 4.90  | 2.00   | 0.20   | 0.20  | 0.25 | 53.84 |
| peak                 | 4.90  | 2.20   | 0.20   | 0.20  | 0.25 | 59.34 |

**CAUTION**

Never install option boards that exceed the available expansion box wattage. A single option or a combination of options that needs more than 19 watts can damage the expansion box circuitry, blow a fuse in the workstation, or damage the VAXmate workstation power supply.



# ***Chapter 2*** ***Troubleshooting the*** ***VAXmate Workstation***

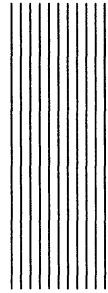

## **2.1 Introduction**

This chapter describes how to diagnose problems in the VAXmate workstation to the failing FRU. It describes the VAXmate diagnostic tests and how to use them. It also describes the VAXmate light emitting diodes (LEDs), their locations and functions.

This chapter does not describe how to troubleshoot the network. If you suspect a problem in the network, see Chapter 3, ThinWire Ethernet.

### **2.1.1 Diagnostic Tests**

The VAXmate workstation has three diagnostic tests to help isolate problems. The tests vary in level of testing.

1. Power-Up
2. Extended Self-Test
3. Service Diagnostics

#### **2.1.1.1 Power-Up Test**

This is the most basic of the three VAXmate diagnostic tests. It is stored in the VAXmate firmware and is referred to as a ROM-based diagnostic. It performs a quick check of 80 percent of the VAXmate workstation, including the CPU board, keyboard, I/O board, video subsystem, diskette drive, hard disk controller and drives (if present), and any DIGITAL options that have on-board diagnostics. Power-Up test also checks only the real mode memory (768 Kbytes).



The Power-Up test starts automatically when the VAXmate workstation is turned on and runs for about 30 seconds. When the test is complete the system boots. If the Power-Up test finds a failure, an error number displays in the middle of the screen, the LED on the failing FRU stays on (if that component has an LED), testing stops, and the system tries the boot procedure.

The Power-Up test does not test options that are not supported by DIGITAL unless the vendor adds option ROMs containing a Power-Up test that conforms to the VAXmate standard. The Power-Up test does check, however, the size of the non-DIGITAL memory and does initialize it.

### **2.1.1.2 Extended Self-Test**

This is a more thorough test of the system than the Power-Up test. The Extended Self-Test is also a ROM-based diagnostic. It performs the same series of tests as the Power-Up test, as well as more extensive tests on the various components. It checks real memory and protected memory, including the 2 Mbyte memory option board, and the functioning of the 80287 coprocessor option. Extended Self-Test performs extensive internal loopback tests on the printer, communications, and mouse connectors and performs extensive event timer tests. No loopback connectors are required. A formatted high-density diskette must be in the drive and the drive must be locked, otherwise error number 43 displays on the screen. The test does not write to the diskette so any formatted high density diskette can be used; data is not lost. Extended Self-Test also reads the hard disk (if present) and checks any other DIGITAL options that have on-board diagnostics.

Extended Self-Test runs when you press the **Ctrl/Alt/Home** keys (after the power-up test is complete). See Figure 2-5 for the location of these keys. It takes between 3 to 5 minutes to run, depending on the number of options installed in the VAXmate workstation. When the test completes the screen displays a list of the components in the system's configuration. During this time, a background process (invisible to the user) allows the host computer to check the network connection. Pressing any key, after the configuration list displays, begins the boot procedure and stops the background process.



If the test finds a failure, a 2-digit error number displays in the middle of the screen, testing stops, and the system's configuration displays.

**NOTE**

The configuration is displayed if the test passes or if the test finds a failure.

ALWAYS run the Extended Self-Test when you install a new DIGITAL option or when you install or remove the expansion box. Otherwise, the system configuration information (stored in memory) does not get updated. See Paragraph 2.4 to run the Extended Self-Test.

### **2.1.1.3 Service Diagnostics**

These diagnostics thoroughly test the VAXmate workstation. These diagnostics are stored on the VAXmate Service Diagnostics diskette, included in the Maintenance Kit. The Service Diagnostics diagnose the system, as well as some networking functions. There are many different types of tests to select. It is also possible to install new tests or update existing tests on the Service Diagnostic diskette.

Many of the tests are interactive – you are prompted to assist in the testing. Status messages display as the testing progresses, to aid in the diagnostic process.

Each test in the Service Diagnostics package takes between 1 and 25 minutes to run, depending on user interaction. If the test finds a failure, a four-digit error number displays at the bottom left of the screen.

### **2.1.2 Light Emitting Diodes (LEDs)**

Figure 2-1 shows the locations of the VAXmate LEDs. Table 2-1 lists the function of each LED.

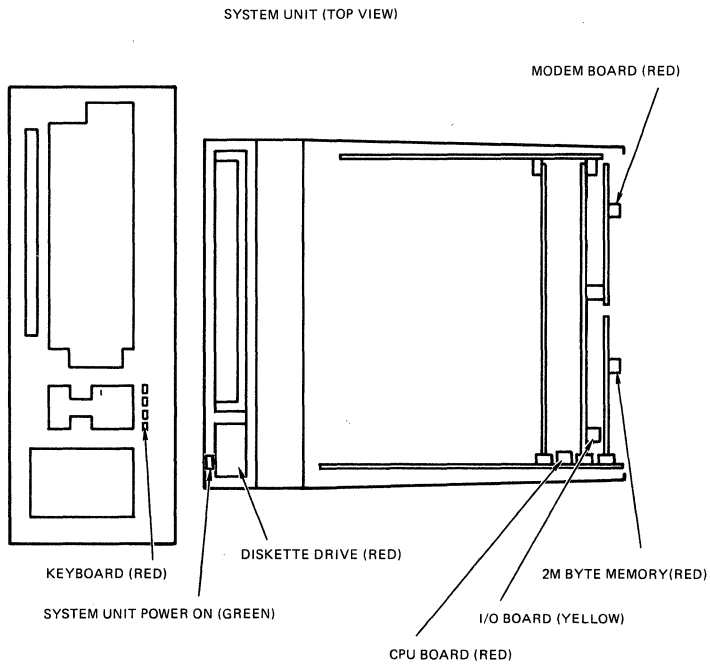

LJ-0897

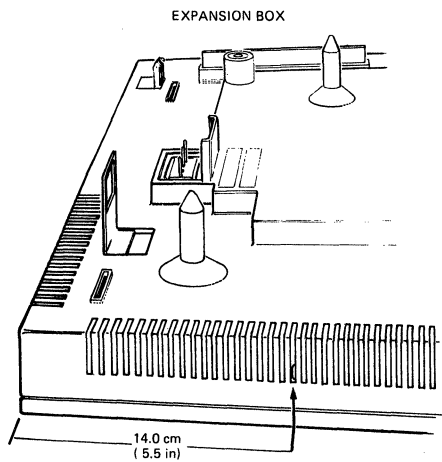

LJ-0898

Figure 2-1 LED Locations



Table 2-1 lists the function of each LED.

**Table 2-1 LED Function**

| Location            | Color  | Function   |
|---------------------|--------|--|
| System unit         | Green  | On when the VAXmate workstation power is on.   |
| Keyboard            | Red    | The four red LEDs are on momentarily during keyboard reset and during the diagnostics.             |
| CPU board           | Red    | On during the CPU board part of the diagnostic. The LED stays on if there is a CPU board failure.  |
| I/O board           | Yellow | On during the I/O board part of the diagnostic. The LED stays on if there is an I/O board failure. |
| Option memory board | Red    | Off during testing and on if there is a parity error on the board.                                 |
| Option modem board  | Red    | On during testing and stays on if there is a failure on the board. Can also blink during failure.  |
| Expansion box       | Green  | On when the system unit power switch is on.  |
| Diskette drive      | Red    | On when drive is operating.  |

## 2.2 Troubleshooting Procedure

Troubleshoot the VAXmate workstation as follows.

1. Run the Power-Up test (Paragraph 2.3). See Appendix C for the error codes.
2. Turn the system off, wait 15 seconds, and turn the system on. Then, run the Extended Self-Test (Paragraph 2.4) if you have not found the problem.

**NOTE**

You must always run the Extended Self-Test when a new option is installed or when the expansion box is installed or replaced. Running the Extended Self-Test updates the system configuration.

3. Run the Service Diagnostics (Paragraph 2.5), if you still have not found the problem.
  - a. Run the System Test to isolate the problem.





- b. Run the Individual Test(s) to confirm a problem area. Individual Test descriptions are in Appendix B.

If you run the individual network tests and you have not found the problem, see Chapter 3, ThinWire Ethernet.

- c. If you replace the CPU, install the original Ethernet address ROM on the new CPU board. If you replace either the CPU or I/O-video board, run the system test to check the system.
- d. If you replace an option, run the Individual Test for that option.

## **2.3 Power-Up Test**

Run the Power-Up test as follows.

1. Turn off the system power and wait 15 seconds.
2. Turn on the system power.

See Figure 2-2 for a flowchart of the ROM diagnostic test sequence.

A successful test produces these results.

1. The system unit LED is on showing power to the VAXmate workstation. If an expansion box is attached, its LED is also on.
2. A horizontal hollow bar displays and fills in as the test progresses.
3. The screen goes blank, then the top line flashes and blinks as the video components are tested.

If a non-DIGITAL video option is present, the Power-Up test does not perform the video test.

4. The LEDs for the CPU board, I/O board, and DIGITAL option boards are on during their part of the test and shut off when the test for that board completes.
5. The system speaker beeps once and the horizontal bar is completely filled in when the test is successful.
6. The system boots from either the diskette (if one is in the drive), the hard disk (if one is installed and formatted), or the network (if one is connected), in that order.



TEST SEQUENCE—PROCESSOR BOARD

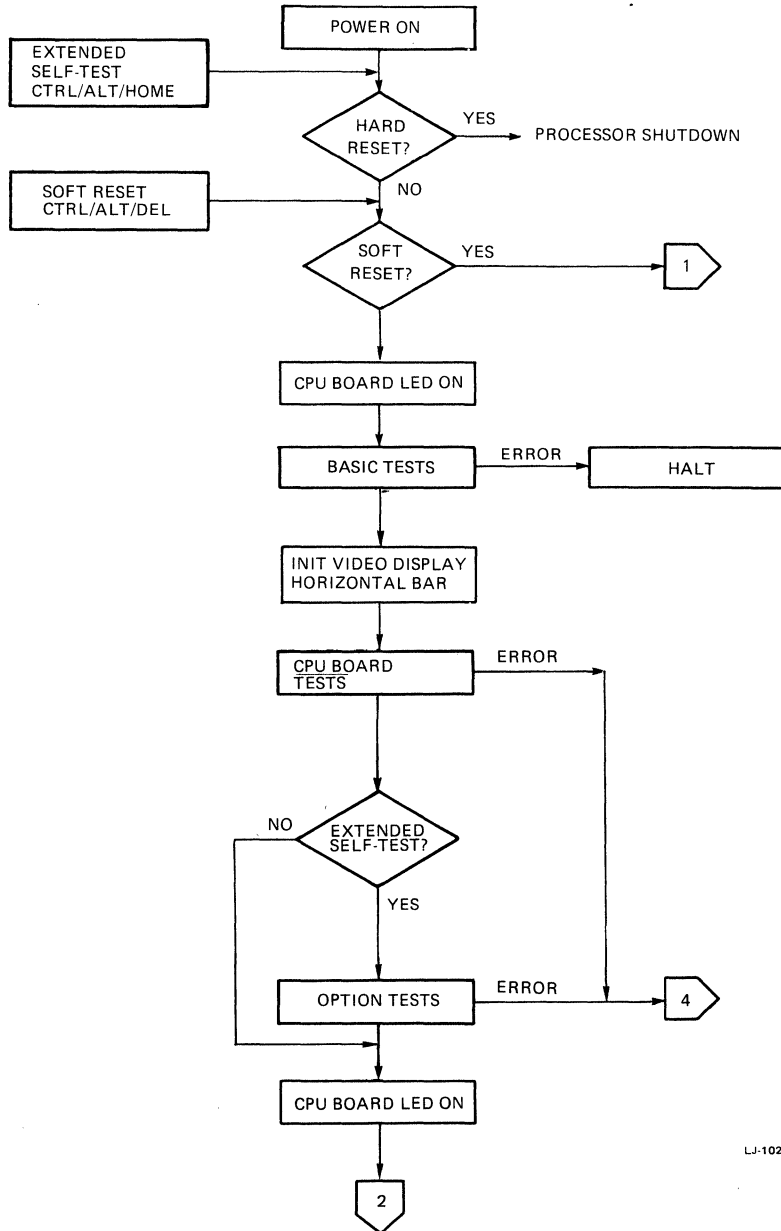

LJ-1028

Figure 2-2 ROM Diagnostic Test Sequence (Sheet 1 of 3)



TEST SEQUENCE--I/O BOARD

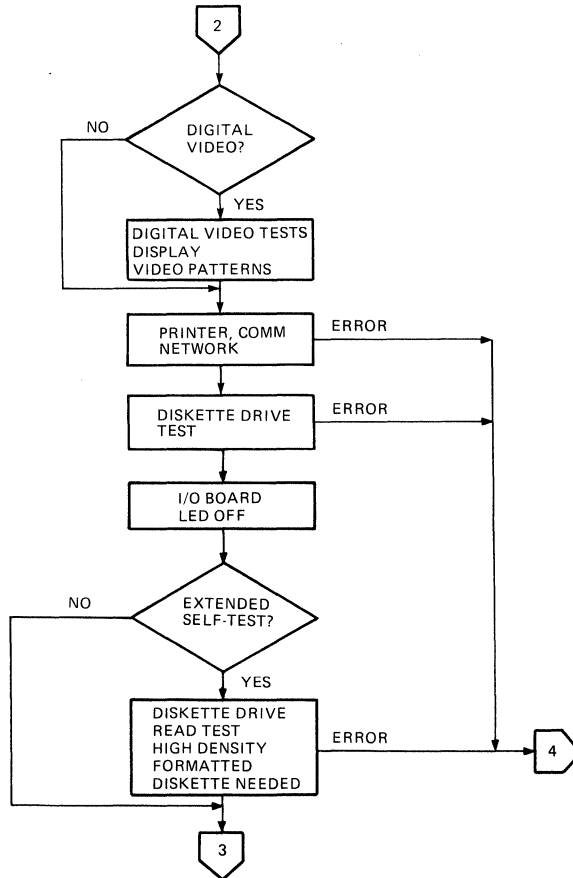

LJ-1029

Figure 2-2 ROM Diagnostic Test Sequence (Sheet 2 of 3)



TEST SEQUENCE—OPTIONS

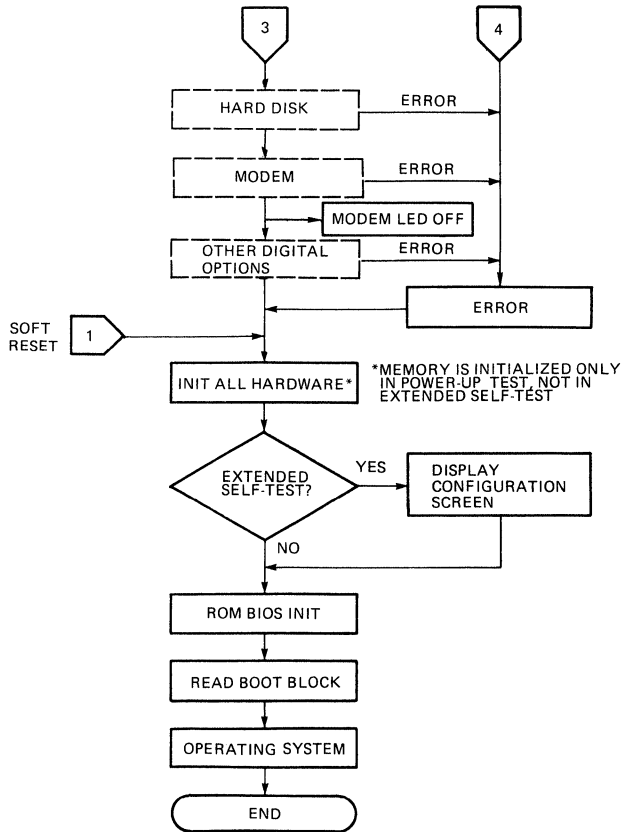

LJ-1030

Figure 2-2 ROM Diagnostic Test Sequence (Sheet 3 of 3)



If ALL of the previous results did not occur, do the following.

| <b>Symptom</b>   | <b>Action</b>  |
|--|--|
| No video display.  | See Table 2-2, Symptoms.   |
| LEDs are not functioning properly.   | See Table 2-2, Symptoms.   |
| System halts – CPU LED stays on.   | See Paragraph 2.3.1, System Halt. Also see Table 2-2, Symptoms.  |
| System halts – I/O LED stays on.   | See Paragraph 2.3.1, System Halt. Also see Table 2-2, Symptoms.  |
| Horizontal bar is not displayed.   | See Paragraph 2.3.2, CPU Board Jumpers. Jumper W1 on CPU board must be in. If removed, replace it. Also see Table 2-2, Symptoms.   |
| Wrong characters on the screen, or the display is not correct.                                       | The modem jumper is set to disable the modem portion of the ROM diagnostics. Enable the modem testing by setting the jumper to pins 2 and 3. (See Figure 5-12). Also read Paragraph 2.4.1.1. |
| Horizontal bar is partially filled in. No numbers are displayed, and the system doesn't try to boot. | See Paragraph 2.3.2, CPU Board Jumpers. Jumper W2 on CPU board must be out. If there is a jumper in this position, remove it.  |
| Two-digit number displays. System may or may not boot.   | See Paragraph 2.3.3, Error Numbers.  |
| Power supply and CPU errors occur.   | The expansion box runs off of the CPU board. The expansion box power regulator may be the source of the problem. Remove the expansion box and run the Extended Self-Test.                    |
| EGA/network conflict   | Install the PC500-UA CPU board and grounding kit.  |



**Table 2-2 Symptoms**

| Indicator LEDs               |     |     | Option Indicator LEDs |                |       | Probable Cause                    | Corrective Action   |
|------------------------------|-----|-----|-----------------------|----------------|-------|-----------------------------------|---|
| System Unit                  | CPU | I/O | Expansion Box         | 2 Mbyte Memory | Modem |                                   |   |
| No Video Displayed on Screen |     |     |                       |                |       |                                   |   |
| off                          | off | off | off                   | off            | off   | ac power cable                    | Plug in cable   |
|                              |     |     |                       |                |       | Power switch                      | Make sure power is on.  |
|                              |     |     |                       |                |       | Blown fuse                        | See Paragraph 2.3.4.3.  |
|                              |     |     |                       |                |       | VAXmate workstation power failure | See Paragraph 2.3.4.  |
|                              |     |     |                       |                |       | Expansion box options.            | Detach the expansion box from the system unit and try to power-up again. If it passes, then reseat each option. Continue with troubleshooting procedures. Remove options if they are faulty. Replace only DIGITAL supported options. Inform customer of faulty options that are not supported by DIGITAL. |

Table 2-2 Symptoms (*cont.*)

| Indicator LEDs |     |     | Option Indicator LEDs |                |       | Probable Cause  | Corrective Action  |
|----------------|-----|-----|-----------------------|----------------|-------|---|--|
| System Unit    | CPU | I/O | Expansion Box         | 2 Mbyte Memory | Modem |   |  |
|                |     |     |                       |                |       | Power supply board  | Reseat the board. If conditions persist, replace the board.  |
| on             | off | off | on                    | off            | off   | Brightness/contrast<br>Screen saver is on.<br>Monitor board | Adjust the controls. Press any key to refresh the screen. Adjust brightness control to maximum to check if raster is displayed. If not, replace monitor board. |
| on             | on  | off | —                     | —              | —     | CPU board   | Reseat. Replace if conditions persist.   |
| on             | off | on  | —                     | —              | —     | I/O board   | Reseat. Replace if conditions persist.   |

**Table 2-2 Symptoms (cont.)**

| Indicator LEDs            |     |     | Option Indicator LEDs |                |                 | Probable Cause                                      | Corrective Action  |
|---------------------------|-----|-----|-----------------------|----------------|-----------------|---|--|
| System Unit               | CPU | I/O | Expansion Box         | 2 Mbyte Memory | Modem           |   |  |
| Video displayed on screen |     |     |                       |                |                 |   |  |
| on                        | off | off | on                    | off            | off             | Normal settings                                     | No corrective action is necessary.                                       |
| off                       | off | off | on                    | off            | off             | System unit LED                                     | Check LED connection and CPU board. Replace LED assembly if blown.       |
| on                        | on  | off | —                     | —              | —               | CPU board jumpers                                   | Check jumpers. See paragraph 2.3.2.                                      |
|                           |     |     |                       |                |                 | CPU board   | Reseat. Replace if conditions persist. See Appendix C for error numbers. |
| on                        | off | on  | —                     | —              | —               | I/O board   | Reseat. Replace if conditions persist. See Appendix C for error numbers. |
| on                        | off | off | on                    | on             | off             | Memory option                                       | Reseat. See Appendix C for error numbers.                                |
| on                        | off | off | on                    | off            | on (or flashes) | Modem option  | Reseat. See Appendix C for error numbers.                                |
| on                        | off | off | off                   | off            | off             | Expansion box not correctly attached to system unit | Check pins on expansion box.   |
|                           |     |     |                       |                |                 | Power regulator                                     | Reseat. Replace if faulty.   |





**Table 2-2 Symptoms (cont.)**

| <b>Indicator</b>       | <b>Probable Cause</b>    | <b>Corrective Action</b>   |
|------------------------|--------------------------|--|
| Diskette drive LED on  | Diskette drive or cables | Make sure all cables are secure and not damaged. If the drive is faulty, see Appendix C for error numbers. |
| Speaker does not sound | Speaker cable            | Make sure the speaker cable is not damaged and is firmly plugged into the CPU board.                       |
|                        | Speaker driver           | Replace the CPU board.   |
|                        | Speaker                  | Replace the speaker.   |
| Keyboard LEDs off      | Keyboard connection      | Make sure the keyboard cable is firmly plugged in. Turn power off, then on again.                          |
|                        | CPU board                | Keyboard fuse is soldered to CPU board for keyboard safety. Replace CPU board and keyboard.                |



### 2.3.1 System Halt

There are only a few subtest failures that are severe enough to cause the system to halt.

- Memory access
- Data path validity
- Address
- ROM checksum
- Stack and vector area
- Refresh request
- CMOS shutdown byte.

If the CPU board LED stays on and the system speaker beeps twice, replace the CPU board. See Chapter 5, FRU Replacement.

Initializing the video gate array chip may also cause the system to halt. If the I/O board LED stays on, and no error number is reported, replace the I/O board. See Chapter 5, FRU Replacement.

### 2.3.2 CPU Board Jumpers

The ROM diagnostics will not run correctly if the three jumper locations on the CPU board are configured incorrectly. Make sure the jumpers are configured as follows. See Figure 2-3.

- W1 - Installed
- W2 - Removed
- W3 - Installed if the system DOES contain a diskette drive. Removed during manufacturing testing without diskette drive in system.

#### **NOTE**

If the VAXmate workstation DOES have a diskette drive, make sure that jumper W3 is installed, otherwise the ROM diagnostics will not test the diskette drive. Jumper W3 may have been removed at the factory when manufacturing tested the VAXmate workstation without a diskette drive.

If the VAXmate workstation DOES NOT have a diskette drive, make sure to remove jumper W3. If the jumper is not removed, the ROM diagnostics will report error number 40 (drive A recalibration test) – the drive was not found, therefore the recalibration test could not be performed. The VAXmate workstation stops the test and tries to boot from the hard disk, then the network.

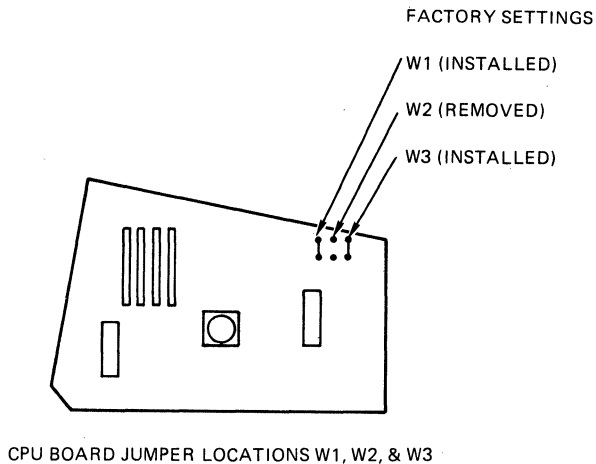

LJ-0899

**Figure 2-3 CPU Board Jumpers**

### 2.3.3 Error Numbers

If the test detects an error the following occurs:

- The horizontal bar brightens.
- A two-digit error number displays.
- The system speaker beeps twice.
- The VAXmate workstation tries to boot.

**NOTE**

See Appendix C for a complete list of error number and the test that failed.



To correct the error, follow these steps.

1. If error number 40, 60, 83 (or 87) displays, do the following.

- 40 – Drive A recalibration failure

Make sure the diskette drive cable is firmly connected. Repeat the test.

If the system does not have a diskette drive, make sure jumper W3 on the CPU board is removed. Repeat the test. (See Paragraph 2.3.2).

- 60 – Keyboard not recognized

Turn off the VAXmate workstation power. Make sure the keyboard is firmly plugged in.

Turn on the power. If the keyboard is still not recognized, turn off the power and replace the keyboard.

Turn on the power. If the keyboard is still not recognized, and the keyboard LEDs are off, the problem is the CPU board. There is a keyboard protection fuse soldered to the CPU board. Replace the CPU board (make sure to keep the keyboard plugged in because the original keyboard has a fault that caused the fuse to blow on the CPU board.

Turn on the power.

- 83 (or 87) – Drive 0 (or drive 1) hard disk not formatted

This error can occur for the following reasons.

- Hard disk controller is not seated correctly.
- Hard disk is newly installed and is not formatted.
- Sometimes this error occurs on formatted drives; in which case, **back up disk if necessary**. Then, tell the customer to format the disk by using the MS-DOS FDISK and FORMAT commands. These commands are on the customer's keydisk.



2. If any other error number displays, find the error number in Appendix C. This appendix lists error numbers and corresponding FRUs. Make sure the FRU is firmly seated before replacing it.

**NOTE**

When the system boots, the error number moves to the middle of the top line. It stays there until scrolled off the screen either by the system or you.

3. Run the Power-Up test again.
4. If the same error number displays again, replace the faulty FRU. See Chapter 5, FRU Replacement. If you replace a monitor board or CRT assembly, make the necessary monitor adjustments. See Chapter 4, Monitor Adjustments.

**NOTE**

If the system boots while showing an error number, you must still replace the faulty FRU.

5. Run the Power-Up test again to make sure you have corrected the problem and that there are no more failing FRUs.

**NOTE**

Only one error number displays. Correct the error by reseating or replacing the FRU, then run the Power-Up Test again to make sure there are no more errors.

6. Run Extended Self-Test.

### **2.3.4 What To Do If the VAXmate Power Shuts Down**

The VAXmate workstation can shut off automatically, or fail to power-up, for one of several reasons.

- Thermal shutdown/overvoltage
- Overcurrent shutdown
- Blown fuse or short circuit due to:

A component in the system unit,

A component in the expansion box, or

A faulty connection between the system unit and the expansion box.



### 2.3.4.1 Thermal Shutdown/Overvoltage

If the VAXmate workstation overheats, it automatically shuts down. This is called thermal shutdown. If the VAXmate system unit overheats, it shuts down. If, however, an expansion box overheats and shuts down, it does NOT cause the system unit to shut down. The VAXmate workstation is rated as an environmental Class A system. The temperature in the room must be between 56° and 90° F (13° to 32° C) to operate the VAXmate workstation. In addition, the VAXmate computer needs 10 centimeters (4 inches) of clearance around it for air circulation. Make sure the vents are clear and NOTHING is resting on the computer.

#### **CAUTION**

If there is an overheating problem, the diskette in the drive may get damaged before the VAXmate workstation automatically shuts down.

Test for thermal shutdown as follows.

1. Turn off the power.
2. Remove the diskette from the drive to make sure it is not warped or damaged.
3. Let the VAXmate workstation cool for 15 seconds.
4. Turn on the power. Power should be restored. If power is not restored, and the green power LED is not on, there may be a blown fuse or a problem relating to the power supply. If an expansion box is present and its LED is off, check the expansion box for short circuit or overcurrent shutdown.

### 2.3.4.2 Overcurrent Shutdown

A non-DIGITAL option can require more than the allowable current. If this happens, the system unit and/or expansion box might not power up. This is evident if the system unit power LED is on and the expansion box LED is off (if an expansion box is present). Do the following.

1. Turn off the power and wait 15 seconds.
2. Turn the power on. If the power is present, run the Extended Self-Test.



3. If the power still fails, remove the non-DIGITAL options.
4. Check the options to make sure they meet DIGITAL electrical specifications for the industry-standard option slots (Chapter 1). If they do not meet the DIGITAL specifications, tell the customer.
5. Turn on the power.
6. If the power still fails, replace the hard disk or hard disk controller.
7. Test the power. If it fails again, replace the power regulator.

### **2.3.4.3 Blown Fuse or Short Circuit**

A fuse can blow when there is a power overload or short somewhere within the system unit or expansion box. Each time you test the power in the following steps, make sure to check the fuse and replace it if necessary; see Paragraph 5.3.3. Correct the problem as follows.

1. Turn off the power switch. Let the VAXmate workstation cool for 15 seconds.
2. Turn on the power. If the power fails to come on, go to step 3.

**NOTE**

If the system unit power LED is on, but the expansion box LED is off, go to step 5.

3. If no expansion box is present, go to step 8.

If an expansion box is present, separate it from the system unit. See Chapter 5, FRU Replacement. Replace the system unit fuse if it is bad. (There is no fuse on the expansion box).

4. Turn the system unit power on. If the power fails again, go to step 8. The problem is in the system unit.

If the power stays on, however, the problem is in the expansion box.



5. Remove all non-DIGITAL options in the expansion box then test the power as follows.
  - a. Replace the bad fuse on the system unit.
  - b. Reattach the expansion box to the system unit.
  - c. Turn on the power.

If the power stays on, then the problem is one of the non-DIGITAL options or the option slot itself. Go to step 6. If there is still no power, go to step 7.

6. Test the option slot as follows.
  - a. Remove the option from the suspected faulty slot.
  - b. Install the hard disk controller board into that slot.
  - c. Turn on the power. If the hard disk functions, then the slot is good. Inform the customer that one of the non-DIGITAL options is causing the problem.

**NOTE**

See Table 1-1, Electrical Description. The two option slots in the expansion box can only accept industry-standard options that require power of 9.5 watts/slot maximum and a clock frequency of 8 megahertz. The slots use an industry-standard bus with 8 or 16 bits.

7. Try to restore power as follows.
  - a. Check the expansion box pins that connect to the system unit. Make sure they are not damaged or touching each other. If they are damaged or touching each other, fix them and test the power again. If the power is present, go to step 11.
  - b. Unplug the hard disk cable from the power regulator board.
  - c. Test the power. If the power is present, replace the hard disk and go to step 11.
  - d. Unplug the controller board.
  - e. Test the power. If the power is present, replace the controller board.





- f. Test the power. If the power is present, go to step 11.
  - g. If the power still fails, replace the power regulator or the connections to the power regulator. If the power is present, go to step 11.
8. Remove the modem option and the 2 Mbyte memory option one at a time, if they are present; then test the power by replacing the fuse and turning on the power. If the power is present, replace the options and go to step 11 to complete the test procedure.
  9. Replace the system unit power supply board (see Chapter 5, FRU Replacement), then test the power. If this is successful, go to step 11 to test the VAXmate workstation.
  10. Replace the system unit FRUs one at a time, in the order they are listed here, and test the power each time. Make sure to change the fuse each time if it is blown.
    - Power supply board
    - CPU board
    - I/O board
    - Diskette drive
    - Monitor board
    - CRT
  11. Run the Extended Self-Test.

## **2.4 Extended Self-Test**

Run the Extended Self-Test as follows.

1. Insert a formatted high-density diskette into the drive. See Figure 2-4. The high-density diskette is included in the Maintenance Kit.

### **NOTE**

The diskette drive part of the test only reads the diskette; it does not write on it, therefore, data on the diskette is not lost.

2. Lock the drive by pushing the drive latch down.
3. Press the **Ctrl/Alt/Home** keys at the same time to start the test. See Figure 2-5. The test takes 3 to 5 minutes to run, depending on the number of options installed. During the video part of the test, the screen flashes and blinks.

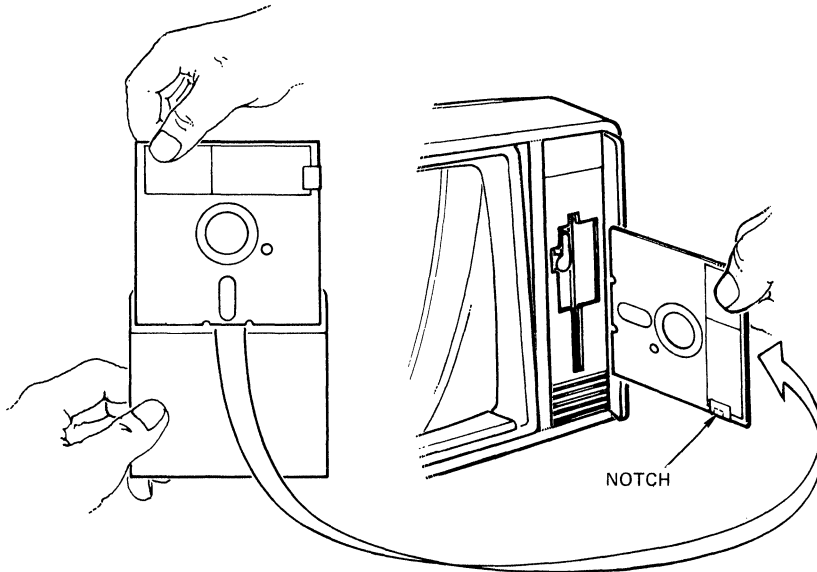

LJ-0900

**Figure 2-4 Inserting the Diskette**

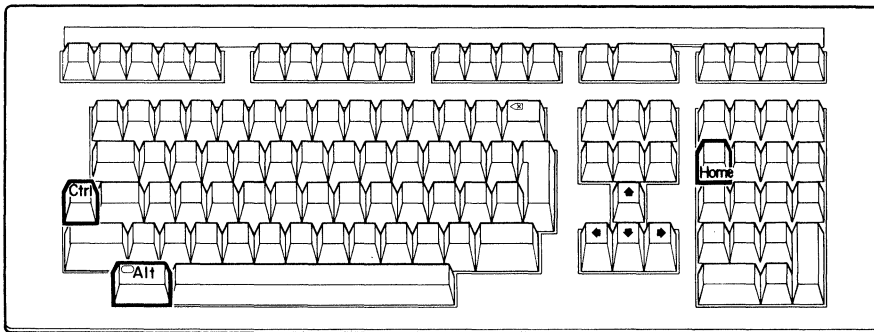

LJ-0901

**Figure 2-5 Extended Self-Test Keys**



A successful Extended Self-Test gives the same results as the Power-Up test (Paragraph 2.3) with these exceptions.

- The system does not start booting.
- The screen displays a configuration list of the system's hardware.

Figure 2-6 is a sample list. If a component is not recognized or an option is not present, a dashed line displays.

**NOTE**

Options, other than those shown in Figure 2-6, are not listed. If Li is not displayed, see step 2 in the next procedure.

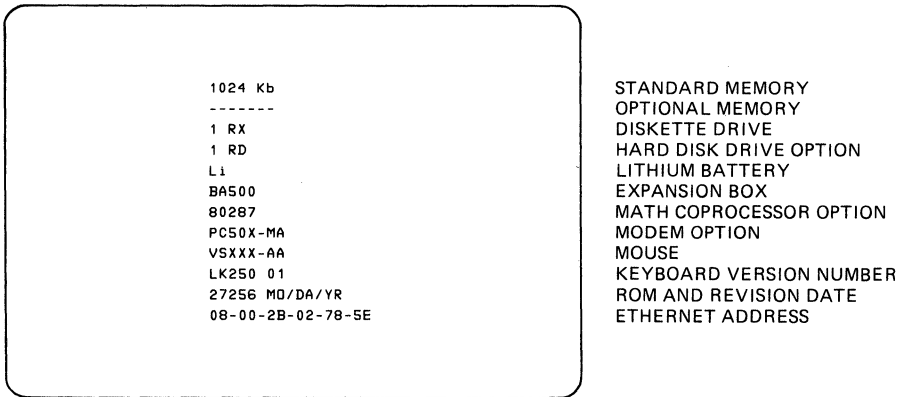

LJ-1031

**Figure 2-6 Sample Configuration Display**

Check the accuracy of the list as follows.

1. If the list is accurate, and there are no error numbers, press any key to start the booting process.
2. If the list is not accurate, the reason is one or more of the following conditions.

An expansion box is present but the lithium battery (Li) is not listed because it was not recognized. Correct the problem as follows.

- a. Turn off the power and wait 15 seconds for the hard disk to stop spinning.



- b. Turn on the power again, and let the Power-Up test complete.
- c. Run the Extended Self-Test again. Make sure Li is displayed in the configuration list. See Paragraph 2.4.1.2, New Expansion Box.

A module needs to be reseated. Do the following steps.

- a. Turn off the system and wait 15 seconds.
- b. Reseat the option you know is missing from the list. See Chapter 5, FRU Replacement.
- c. Run Extended Self-Test again.
- d. If the option still is not on the list, run the Service Diagnostics Individual Test for that component. See Paragraph 2.5.6.

If an error is detected during the Extended Self-Test, the following occurs.

- The horizontal bar brightens.
- A 2-digit error number displays.
- The system speaker beeps twice.
- The LED on the faulty FRU stays on.
- The configuration list also displays.

To correct the error, do the following.

1. Find the error number and the corresponding faulty FRU in Appendix C.

**NOTE**

If error number 43 displays, there is a read error.

Make sure there is a known good formatted, high-density diskette in the drive and that the diskette is inserted correctly.

2. Inspect and reseat the FRU.
3. Run the Extended Self-Test again.
4. If the error number displays again, replace the FRU.
5. Run the Extended Self-Test again.

**NOTE**

There may be more than one failing FRU. Replace all failing FRUs.



## **2.4.1 Exceptions to Testing Results**

### **2.4.1.1 If the Customer Reports a Modem Problem**

If the customer is having problems with the modem, but the Power-Up Test and the Extended Self-Test do not display a modem error number, then check the modem jumper setting. The jumper setting is probably disabling the modem part of the ROM diagnostics. This is NOT an incorrect jumper setting. When there is an industry-standard option in the expansion box, the option may be using the ROM space that the modem needs for ROM diagnostics. Depending upon how the jumper is set (enable or disable) the ROM diagnostics will or will not test the modem. The jumper does not, however, affect the Service Diagnostics modem test.

Test the modem as follows.

1. Run the Service Diagnostics. See Paragraph 2.5.
2. Select the Individual Test mode of the Service Diagnostics. See Paragraph 2.5.6.
3. Run individual test number 17 – Modem Tests.
4. If the VAXmate workstation displays an error number during the test, see Appendix C.

### **2.4.1.2 New Expansion Box**

When an expansion box is first installed do the following steps.

1. Run the Extended Self-Test as follows.
  - a. Turn on the power and let the power-up test complete.
  - b. Turn the power off and wait 15 seconds for the drive to spin down, then turn it on again to clear the power fail bit in the event timer. Allow the Power-Up test to complete. The power fail bit indicates if the battery is present thus controlling Li (lithium battery) in the configuration list.
  - c. Run the Extended Self-Test to display the configuration list.
2. Make sure that Li (lithium battery) and BA500 (expansion box) appears in the configuration list, verifying the operation of the lithium battery. The lithium battery provides back-up power for the event timer on the CPU board.



### **2.4.1.3 New Hard Disk in Expansion Box**

When a hard disk is newly installed, it must be formatted (if it has not already been formatted) by running specific formatting software. If the hard disk is not formatted, error number 83, drive 0 (or 87, drive 1) displays during the Extended Self-Test. Have the customer format the hard disk.

### **2.4.1.4 LA75 Printing Erroneous Characters**

Use the following steps to power-up the printer.

1. Make sure the VAXmate workstation and LA75 are both off.
2. Turn on the VAXmate workstation power first.
3. Then turn on the LA75 power.

Use the following steps to power-down the LA75.

1. Turn off the LA75 power first.
2. Then turn off the VAXmate workstation power.

## **2.5 Service Diagnostics**

To run the Service Diagnostics, follow these steps.

1. Turn off the VAXmate workstation power.
2. Insert the Service Diagnostics diskette in the drive. Push the drive latch down to lock it.
3. Turn on the VAXmate workstation power.

After the Power-Up test completes, the system loads the Service Diagnostics. If at any time you must restart the Service Diagnostics, press the **Ctrl/Alt/Del** keys at the same time. See Figure 2-7.

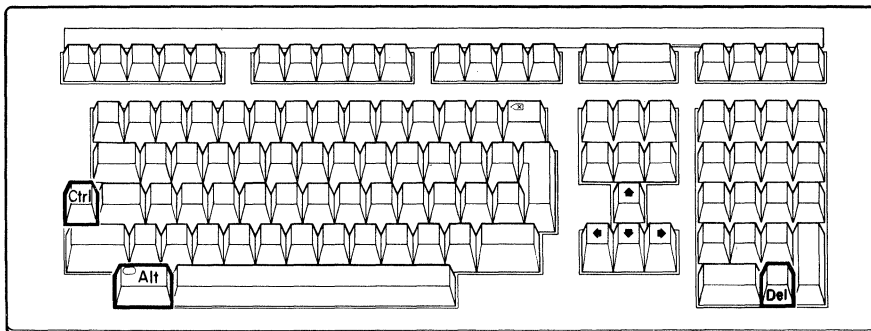

LJ-0902

**Figure 2-7 Restarting Service Diagnostics**

### 2.5.1 System Errors Versus Diagnostic Errors

System errors are operating system errors that can occur any time you are using the Service Diagnostics. These messages are listed in Table C-4. To correct ANY system error, you must start the Service Diagnostics again by doing one of the following.

- Turn the system off, then on again, or
- Restart the Service Diagnostics by pressing the **Ctrl/Alt/Del** keys at the same time.

Diagnostic errors occur if the Service Diagnostics find faulty hardware. When a Service Diagnostic error occurs, a four-digit error number displays at the bottom of the screen. Table C-2, lists these numbers and corresponding FRUs.

### 2.5.2 Previously Detected Error

If either the Power-Up test or Extended Self-Test detected an error, and you did not correct it, the Service Diagnostics displays the screen shown in Figure 2-8 with the two-digit error number. Find the two-digit ROM diagnostic error number in Table C-1, and reseal the faulty FRU. Start the Service Diagnostics again. If the same screen displays again with the same error number, replace the faulty FRU.

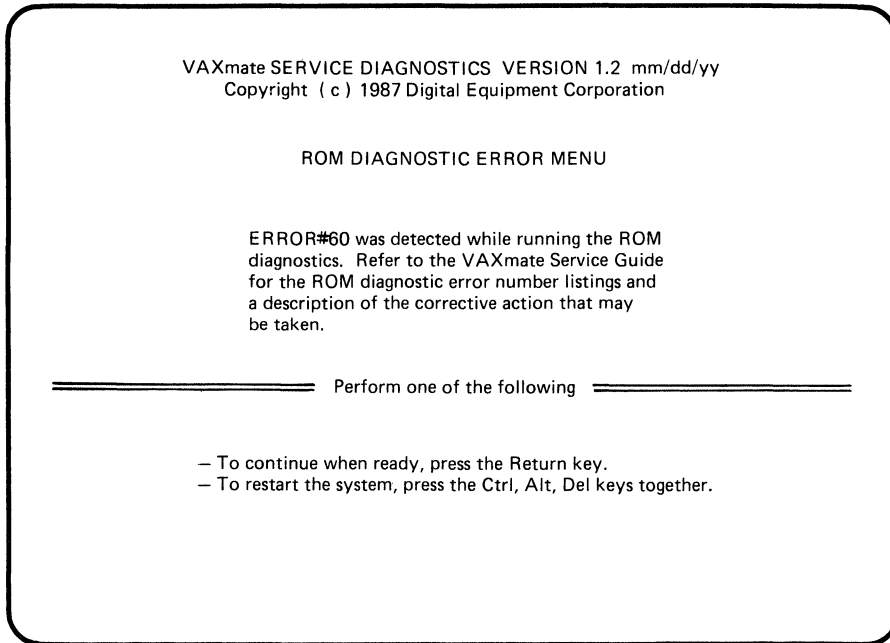

LJ-1033

**Figure 2-8 ROM Diagnostic Error**

Press the **Return** key to continue with the Service Diagnostics.

### 2.5.3 Main Diagnostic Menu

The Main Diagnostic Menu consists of the following items.

1. The System Configuration list
2. The testing status (shown only after the test is executed)
3. A list of the four service diagnostic modes
4. The instructions for choosing a mode. See Figure 2-9.





VAXmate SERVICE DIAGNOSTICS VERSION 1.2 mm/dd/yy  
Copyright (c) 1987 Digital Equipment Corporation

---

SYSTEM CONFIGURATION

|                    |         |                  |                   |
|--------------------|---------|------------------|-------------------|
| Memory size        | 1024 KB | Expansion box    | present           |
| Option memory size | 2048 KB | Modem            | none              |
| Diskette drive(s)  | 1       | Mouse            | present           |
| Hard disk          | present | LK250 keyboard   | present           |
| 80287              | present | ROM rev date     | mm/dd/yy          |
| Battery            | present | Ethernet address | 08-00-2B-02-78-5E |

---

MAIN DIAGNOSTIC MENU

⇒ 1 SYSTEM TEST [default]  
\*2 Individual tests  
3 New diagnostic installation  
4 Error log

Perform one of the following

- To select an option, use the arrow keys to move the pointer, then press the Select key.
- To start the selected option, press the Return key.
- To restart the system, press the Ctrl, Alt, Del keys together.

LJ-1034

Figure 2-9 Main Diagnostic Menu

The system configuration lists the hardware recognized by the VAXmate workstation. If the list is not accurate, try to update it as follows.

**NOTE**

Do not remove the Service Diagnostics diskette to update the configuration list.

1. Run Extended Self-Test by pressing **Ctrl/Alt/Home**. Let the test complete.
2. Start the Service Diagnostics again by pressing the **Return** key.
3. Check the accuracy of the system configuration list. If the list is still incorrect, there may be a hardware or interconnection problem. Reseat the unrecognized FRUs, then perform steps 1 through 3 again. If the list



is still incorrect, run the Individual Test for the unrecognized FRU. See Paragraph 2.5.6 and Appendix B for a description of the Individual Tests in the Service Diagnostics.

The testing status displays the word PASSED, to indicate that all of the tests passed, or the word FAILED to indicate that one or more tests failed. These tests apply only to the Service Diagnostics. The testing status does not display the first time you see the Main Diagnostics Menu.

There are four modes in the Service Diagnostics. Paragraph 2.5.4 explains how to run each of the modes.

1. System Test

This mode checks only the VAXmate system unit and the keyboard – not the expansion box, hard disk, or options. The test itself is non-interactive, although, you are initially prompted to choose an error reporting method and to install loopback connectors. When the test completes, the passed/failed status displays on the Main Diagnostic Menu.

System test takes about 25 minutes to run.

2. Individual Test

This mode can check the VAXmate workstation, the expansion box (including DIGITAL options), and some networking functions. Thus, you can choose to test a part of the system, the entire system, or part of the network. You can also choose an error reporting method. Many of the Individual Tests are interactive, so do not leave the area while running the tests.

The tests vary in length from several seconds to 25 minutes. A summary of each Individual Test and subtest is given in Appendix B.

3. New Diagnostic Installation

This mode updates existing tests, or adds new tests to the Service Diagnostic diskette. Upon completion, the updated or new test is listed on the Individual Test menu.



#### 4. Error log

This mode displays the current list of errors from the test you ran. The error log is the only place in the Service Diagnostics where error numbers, found during testing, are stored.

Both System Test mode and Individual Test mode ask if you want the errors to be recorded in the log. If you choose not to have the errors recorded, then the Error Log mode is not in effect. The default is to have the errors recorded in the log.

The error log lists the following items.

- a. The hard error and soft error counts of all tests run. The maximum count is 9999 errors.
- b. Each subtest in which an error was found. No more than 52 failed subtests are listed. The remainder are not logged.
- c. Each 4-digit error number that corresponds to the failed subtest. Again, no more than 52 are logged.
- d. When the error occurred – the nth time through the test loop. For example, the error occurred on the fourth pass through the test loop.

#### **NOTE**

The word “pass” has two different meanings in the Service Diagnostics. Do not be confused by them. The first means the test was successful (versus unsuccessful). For example, the test passed (versus failed). The second means the number of times the test was run. For example, an error was found on the seventh test pass.

The error log lists the hard errors for all tests. It also lists the soft errors for the diskette test, the hard disk test, and the network test. Soft errors are errors that are internally correctable by the hardware or are correctable after software retries. Soft errors are not displayed on the screen while the test is running, but are logged in the error log. Hard errors are errors that are not correctable by the hardware or by software retries. Hard errors display on the screen while the test is running, and are also logged in the error log.

Appendix C lists the four-digit error numbers and corresponding FRUs.



### 2.5.4 Selecting a Mode from Main Diagnostic Menu

Select a mode as follows.

1. Press the up or down arrow keys to move the screen arrow, or press the number of the mode. See Figure 2-10.
2. Press the **Select** key. An asterisk indicates the selected mode.
3. Press the **Return** key.

The following paragraphs describe how to use each of the four Service Diagnostic modes.

### 2.5.5 System Test Mode

System test takes about 25 minutes to run. To abort the test, press the **Ctrl/PF3** keys. This is not a normal break in testing, therefore, the screen does not display the word passed or failed.

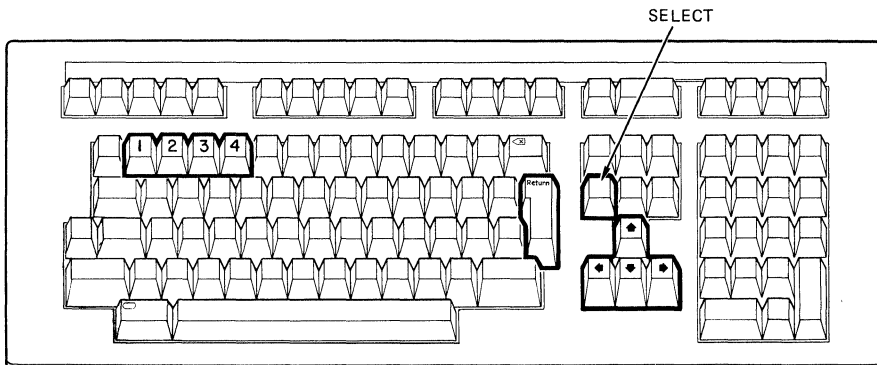

LJ 0903

**Figure 2-10 Service Diagnostics Mode Selection Keys**



### 2.5.5.1 Test Option Menu

The first screen displayed in system test mode is the Test Option Menu (Figure 2-11).

This screen shows the different error reporting methods. Select one option from each group or press the **Return** key to select the default options. An asterisk indicates the selected option.

1. "Prompt on error" causes system test to halt when an error is found. A small screen displays that asks if you want to proceed from error or loop on error. (Figure 2-12). Prompt on error is a default option.

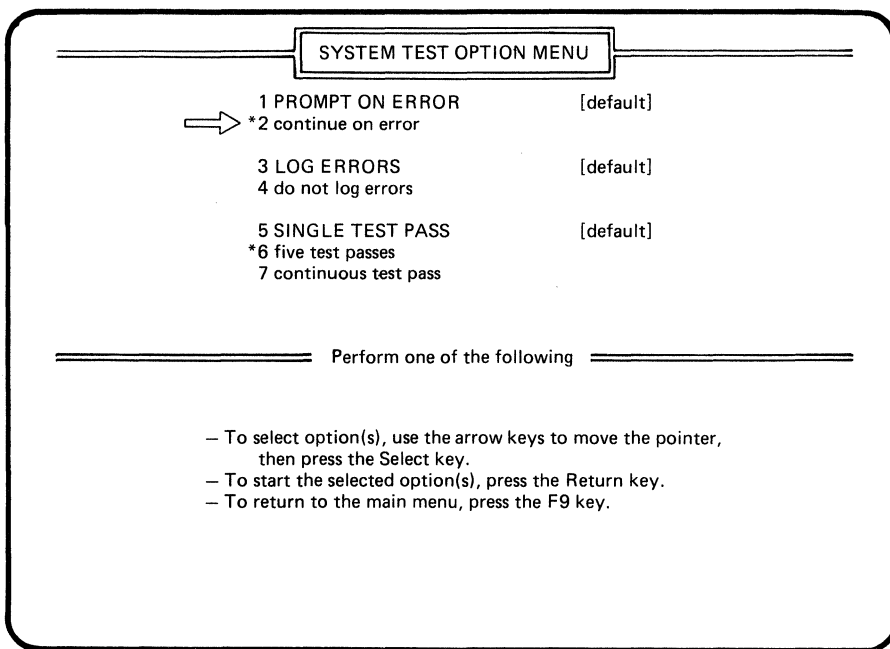

LJ-1035

Figure 2-11 Test Option Menu

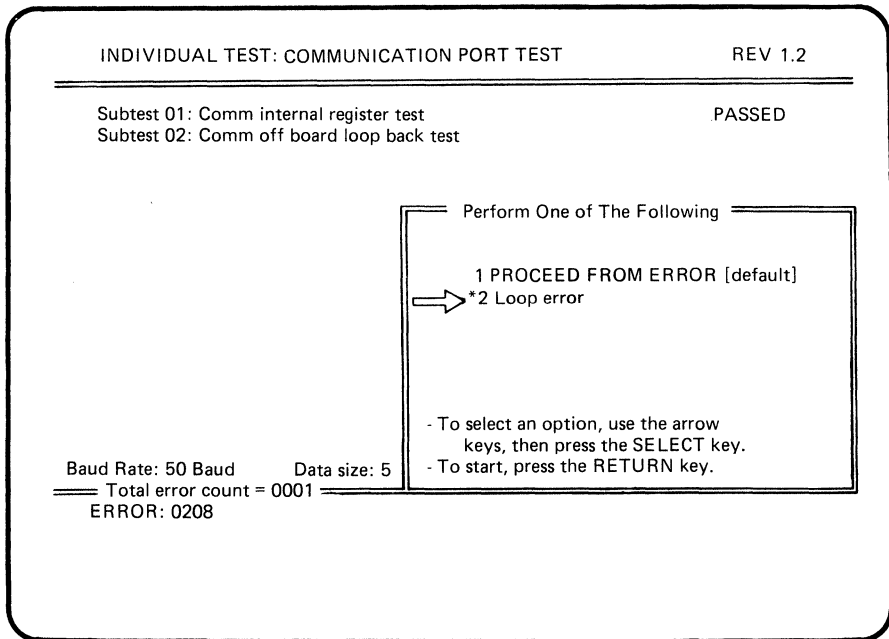

LJ-1036

**Figure 2-12 Prompt on Error**

If you want to “proceed from error,” the test continues from where it found the error. More tests can be affected by the error. Proceed from error is the default. If you want to “loop on error,” the failing test loops as tightly as possible. The test updates and displays the percentage of failures every 10 loops (Figure 2-13). To get out of the loop, press the **Ctrl/PF3** keys.

2. “Continue on error” does not halt the test when an error is found. A four-digit error number displays and the test continues.
3. “Log errors” keeps a log of the errors recorded during testing. After the System Test completes you can view and/or print the error log by selecting mode 4 at the Main Diagnostic Menu. The error log records the total error count and up to 52 errors. It also records the test



number in which the error occurred, and when it occurred. The error log also records any soft errors that can occur. Log errors is a default option.

4. "Do not log errors" does not record any errors found during the system test, however, the total error count is still tallied.
5. "Single test pass" means the system test is executed only once. This is the default option.
6. "Five test passes" means the system test is executed five times.
7. "Continuous test passes" executes the system test indefinitely until you press the **Ctrl/PF3** keys.

**NOTE**

Some parts of the testing disable the keyboard temporarily. Therefore, if the test does not abort, keep typing **Ctrl/PF3** until it does.

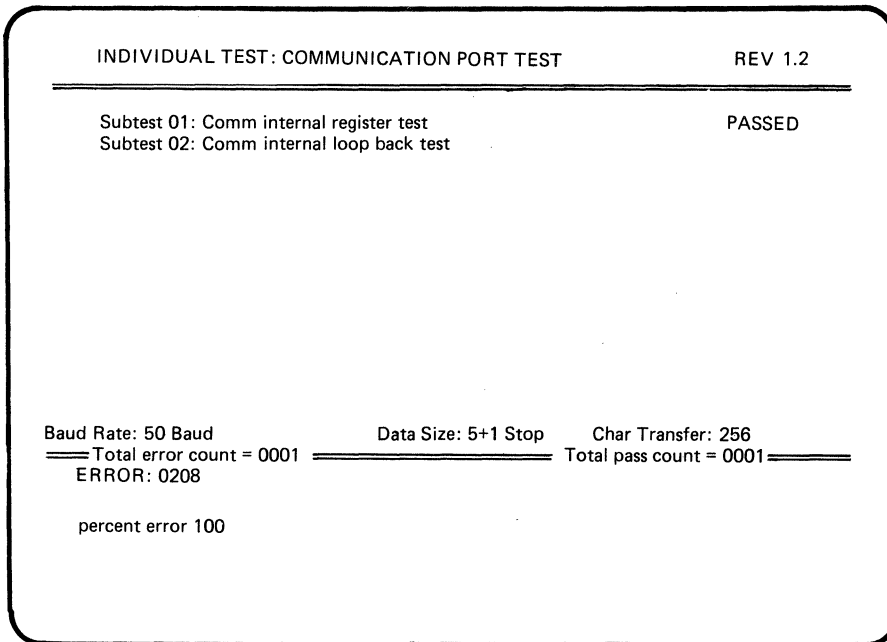

LJ-1037

**Figure 2-13 Loop on Error**



### 2.5.5.2 System Test Requirements

Figure 2-14 shows the System Test Requirements screen.

The loopback connectors, including the T-connector and two terminators, are in the Maintenance kit. To insert the loopback connectors into their respective ports follow these steps. **DO NOT TURN OFF THE VAXmate workstation and DO NOT UNPLUG THE POWER CORD** or you will have to start the Service Diagnostics again.

1. Assemble the network port loopback connector by attaching the two 50-ohm terminators to the opposite ends of the T-connector. See Figure 2-15.

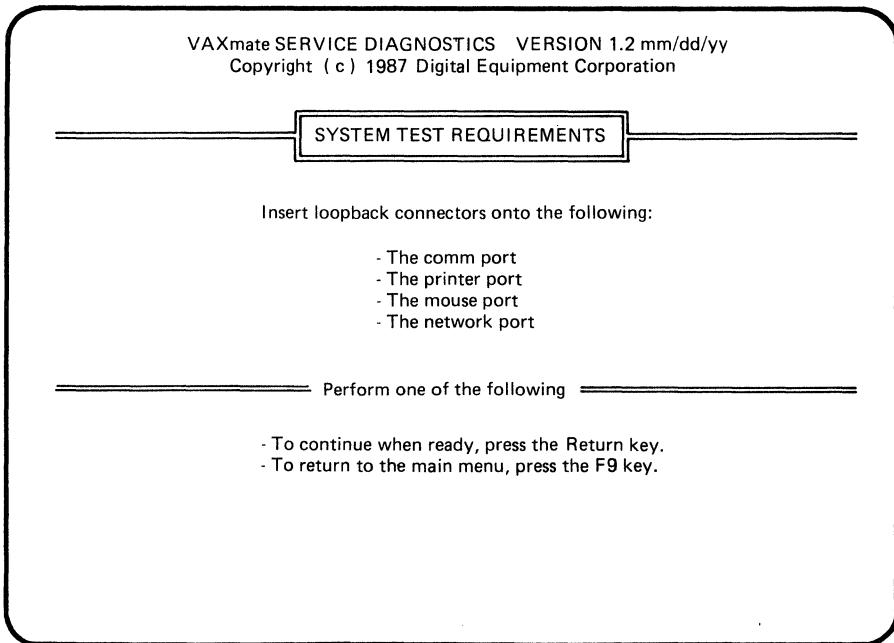

LJ-1038

**Figure 2-14 System Test Requirements**





2. Using extreme caution, disconnect the VAXmate workstation from the network (Figure 2-16).

**CAUTION**

Be VERY careful not to cause a communications break in the network. Unplug the T-connector from the VAXmate workstation. DO NOT unplug the T-connector from the ThinWire Ethernet cable, or from the terminator if one is present.

Do not turn off the VAXmate system or it will be necessary to start the diagnostics again.

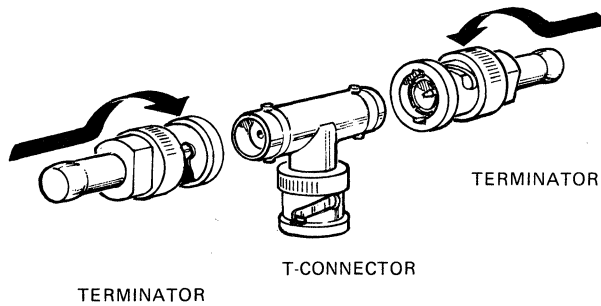

LJ-1045

**Figure 2-15 Assembling the Network Port Loopback Connector**

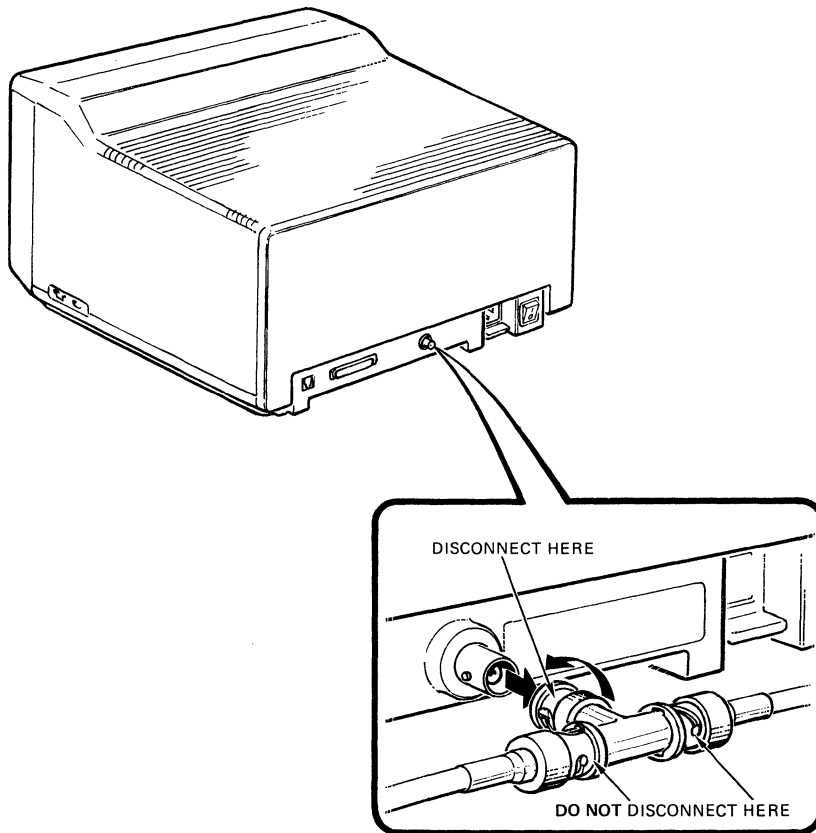

LJ-1046

**Figure 2-16** Disconnecting from the Network



3. Disconnect the following cables if they are present. See Figure 2-17.

Mouse  
Printer  
Communications

4. Plug the loopback connectors into the VAXmate workstation. See Figure 2-18.

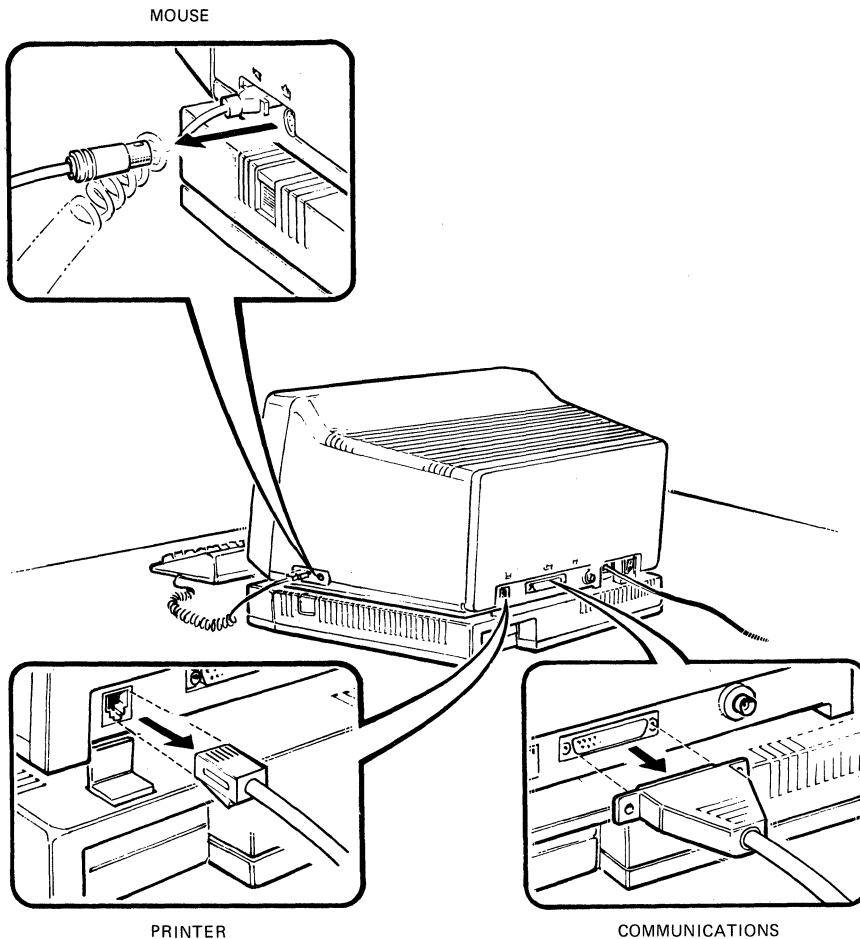

LJ-0905

**Figure 2-17** Disconnecting Mouse, Printer, and Communications Cables

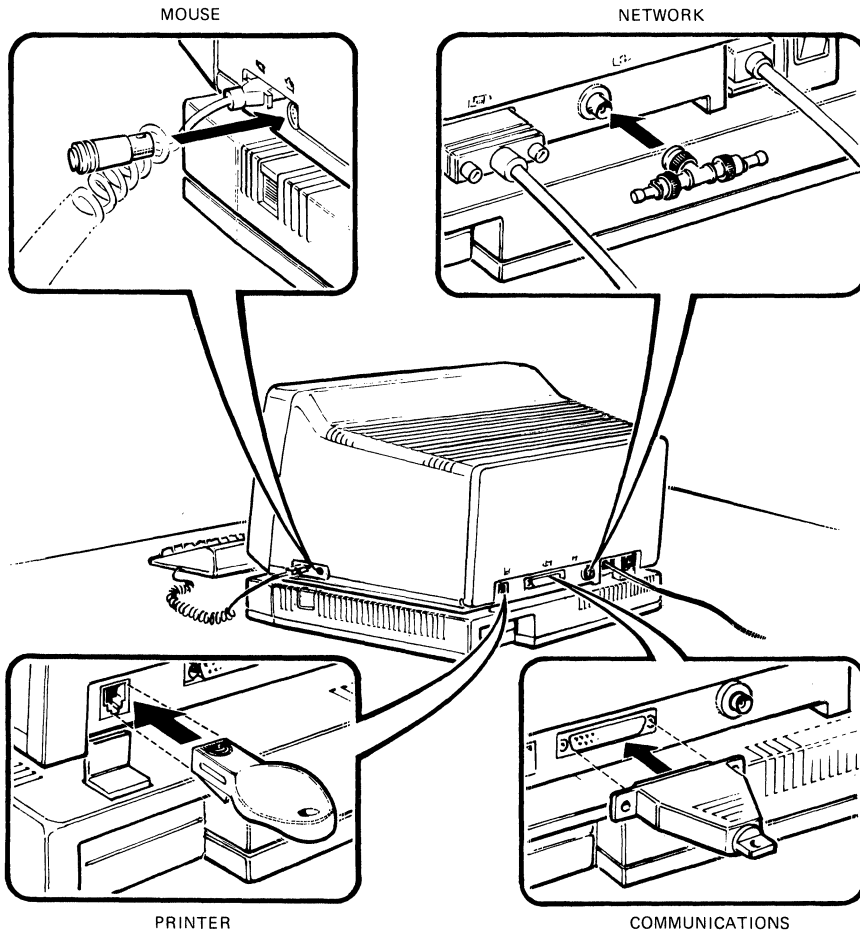

LJ-0906

**Figure 2-18** Installing Loopback Connectors



### **2.5.5.3 System Test Execution**

System test is ready to begin. Press the **Return** key. As the system test is running, the screen displays the following information. See Figure 2-19.

- A list of the system tests. The test that is running is in reverse video.
- The passed/failed/xxxxxxx status of each test.  
If XXXXXXX is displayed, it can mean one of two things:
  - a. It is up to you to determine if the test passed or failed (such as in the speaker test).
  - b. The test was skipped.
- An activity indicator. This is in the upper right corner of the screen and indicates that there is activity – that the test is still executing. Each tick is about 1 second (and counting down). Not all tests use this feature.
- The total number of test passes.
- The total number of errors detected from all completed selected tests.
- A 4-digit error number (if an error is found). This is in the lower left corner of the screen. The error number stays on the screen until a new error is detected or until the next test is loaded.



```

Memory      PASSED  Printer
Comm        PASSED  Mouse
Video       PASSED  Network
Diskette    PASSED  Event Timer
Keyboard
xxxxxxxxxx
xxxxxxxxxx
xxxxxxxxxx

===== Activity indicator = nnnn =====

Subtest 01: F.D.C. Status register test          PASSED
Subtest 02: F.D.C. Data register test           PASSED
Subtest 03: F.D.C. Interrupt capability test    PASSED
Subtest 04: Diskette Drive recalibration test   PASSED
Subtest 05: Diskette Drive step mechanism test  PASSED
Subtest 06: Diskette Drive step rate timing test PASSED
Subtest 07: Diskette Drive hi-speed rotational speed test PASSED
Subtest 08: Diskette Drive verified seek test   XXXXX
Subtest 09: Diskette Drive track/sector read test

Reading track : 48      High density mode      Diskette side 0
===== Total error count = 0000 ===== Total pass count = 0001 =====
    
```

LJ-1039

**Figure 2-19 System Test Execution**

When the test is complete, the following occurs.

- The Main Diagnostic Menu displays after selected number of passes have run.
- The word “passed” displays if the test is successful, or “failed” if there is a failure.

If there is a failure do the following.

1. Read the error log to display the list of errors. Error log is in effect unless you choose not to log errors from the Test Option Menu. See Paragraph 2.5.8 for information about the error log. This also explains how to print the error log.
2. Find the error number(s) in Appendix C.
3. Replace the failing FRUs. See Chapter 5, FRU Replacement.
4. Run the system test again.



## **2.5.6 Individual Tests**

The Individual Test Menu is shown in Figure 2-20. Select a single test or as many of the individual tests as you want. Appendix B describes each test. If you suspect a problem in a particular area of the system, run the individual test associated with that area. Allow all selected tests to run to completion.

### ***NOTE***

The Memory Test runs as the default test if you do not make an individual test selection.

If you suspect a network problem, see Chapter 3, ThinWire Ethernet (Paragraph 3.3).

To abort the test, press the **Ctrl/PF3** keys. However, note the following when using **Ctrl/PF3** to abort testing.

- Some parts of the test disable the keyboard temporarily. Therefore, if the test does not abort, keep trying until it does.
- The word passed, failed, or XXXXXX does not display on the main menu.

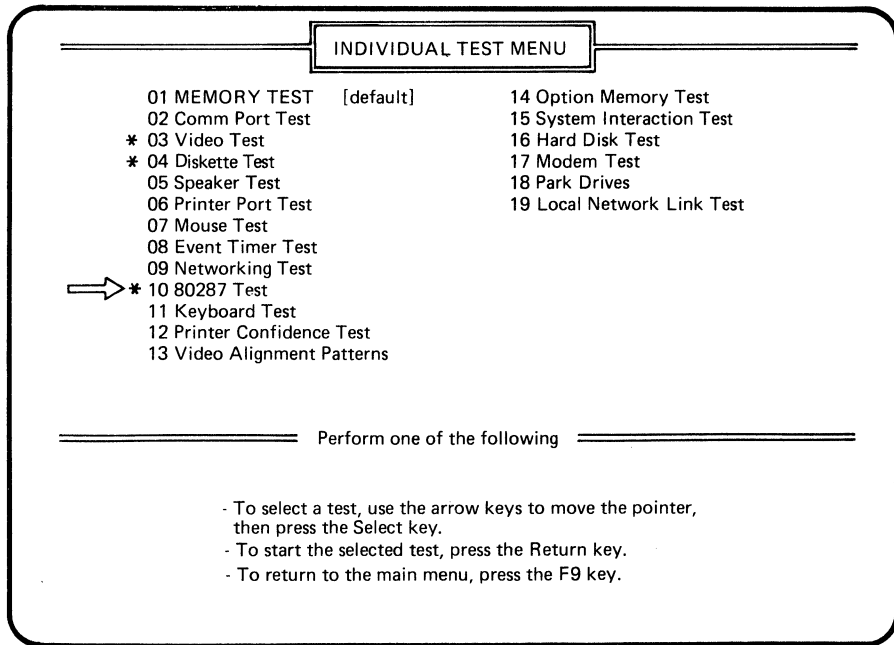

LJ-1040

**Figure 2-20 Individual Test Menu**

To run the individual tests follow these steps.

1. Select the test(s). You can choose as many as you want. See Figure 2-10 for the keys to use.
  - a. Press the up or down arrow keys to move the screen arrow, or press the test number. Press the number keys exactly as the test indicates. For example, for test number 08, type 08.
  - b. Press the **Select** key. An asterisk indicates the selected test. To deselect the choice, press the **Select** key again. This functions like a toggle switch.
  - c. Press **Return**.

The Test Option Menu displays. It is similar to the Test Option Menu shown in Figure 2-11.





2. Select an option from each group or press the **Return** key to select the default options. For a description of the options, read Paragraph 2.5.5.1.
3. Press **Return**.

The Individual Test Execution screen displays (Figure 2-21). It is similar to the System Test Execution screen, explained in Paragraph 2.5.5.3, except for the following differences.

- Only one test displays (test title and revision number).
- You are prompted to set up certain hardware conditions or to respond to certain tests. For example, you may be prompted to insert a loopback plug for the communications test, or verify keyclicks for the keyboard tests.

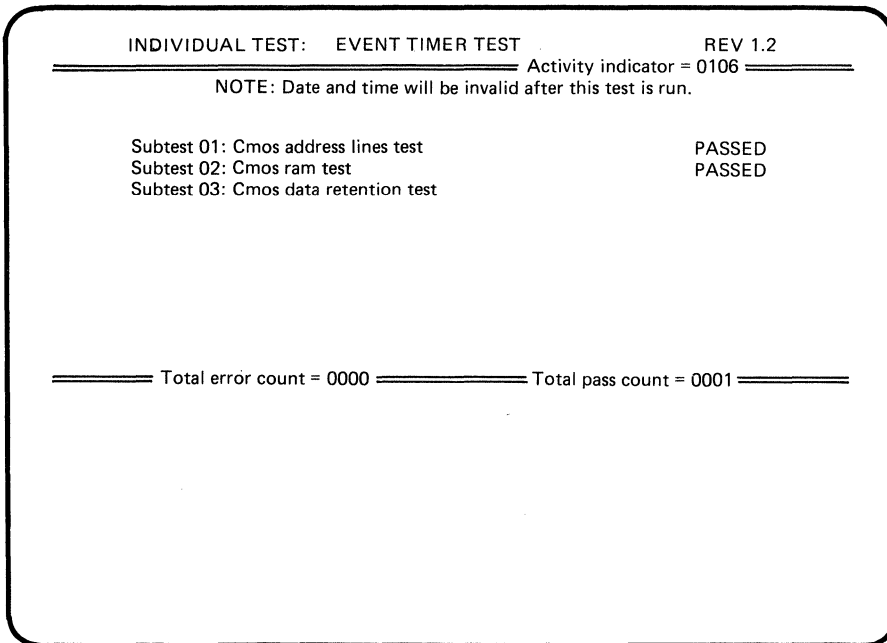

LJ-1041

**Figure 2-21 Individual Test Execution**



**NOTE**

If you have selected either five test passes or continuous test passes from the Test Option Menu, then the Individual Test Execution screen prompts you only the first time through the testing loop.

When the test is complete, the Main Diagnostic Menu displays. The passed/failed status indicates if all the tests passed or any failed. If there are failures do the following steps.

**NOTE**

Soft errors will not cause the overall error status to show FAILED; therefore, if you are testing the hard disk, diskette, or the network, you should view the error log.

1. Choose error log mode to read the list of errors and error numbers. See Paragraph 2.5.8 for information on the error log and printing the error log.
2. Find the 4-digit error numbers in Appendix C.
3. Replace the FRUs. Refer to Chapter 5, FRU Replacement.
4. Run the previously failed test again. If either the CPU board or I/O board were replaced, run the System Test.

### 2.5.7 New Diagnostic Installation

Use this mode to update an existing test or to add a new test to the Service Diagnostics diskette. If an error message displays, see Table C-3, Install New Diagnostic Messages. Each screen prompts you through the procedure, however, note the following as you use this mode.

- This is the only time that you are allowed to remove or insert a diskette if the diskette drive LED is on. (When you are not using New Diagnostic Installation mode, you should not remove or insert a diskette when the LED is on.)
- Make sure the write-protect tab is removed from the Service Diagnostics diskette before you incorporate the tests.
- Do not turn off the VAXmate system power.
- The diskette that contains the new and/or updated tests is referred to as the new disk. The new disk has a maximum of two tests that are to be incorporated on the Service Diagnostics diskette.



- Pressing the **Ctrl/Alt/Del** keys reboots the system and incorporates the tests.

After the tests are incorporated on the Service Diagnostics diskette, do the following steps.

1. Add a new write-protect tab to the Service Diagnostics diskette.
2. Display the Individual Test Menu and run the incorporated tests to make sure they are functioning correctly. Also, observe the revision number.

### **2.5.8 Error Log Mode**

You can view the error log by choosing mode 4 at the Main Diagnostic Menu. If the error log is empty it is because of one of the following conditions.

- The Service Diagnostics did not find any errors.
- You selected the “do not log errors” option from the System Option Menu or the Individual Option Menu.

Figure 2-22 is a sample error log screen.



| ERROR LOG   |                         |                         |
|---|-------------------------|-------------------------|
| Hard error count = 0003   | Soft error count = 0000 | Total pass count = 0001 |
| Test  | Error number            | Pass                    |
| 04  | 0422                    | 0001                    |
| 04  | 0420                    | 0001                    |
| 04  | 0420                    | 0001                    |
| NO MORE RECORDED ERRORS   |                         |                         |
| Perform one of the following  |                         |                         |
| <ul style="list-style-type: none"> <li>- To display more errors, press the Return key.</li> <li>- To return to the first screen, press the Prev screen key.</li> <li>- To print a copy of the screen, press the F2 key.</li> <li>- To return to the main menu, press the F9 key.</li> </ul> |                         |                         |

LJ-1042

**Figure 2-22 Sample Error Log**

To print a copy of the error log on the local printer, press the **F2** key. To view subsequent error message screens, press the **Return** key. Press the **Prev Screen** key to view the first error screen. You can view the log as many times as you need to until you run another test.

The error log is erased when you choose another test and it starts running. Therefore, you cannot display the log again unless you repeat the test.



# *Chapter 3*

## *ThinWire Ethernet*

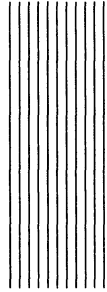

### **3.1 Introduction**

ThinWire Ethernet is an alternative baseband cabling system. It provides full Ethernet capability for personal computers, workstations, and low-end systems in offices and other local work areas. ThinWire Ethernet can connect up to 30 stations, according to the configuration rules, in one 185 meter segment (606 feet).

This chapter gives the following information.

1. A description of the hardware components in a ThinWire network
2. ThinWire Network troubleshooting
3. Installation guidelines and procedures
4. An example of a ThinWire Local Area Network (LAN)
5. A ThinWire Network map and worksheet.

Parts for the ThinWire network are listed in Appendix A. Additional documentation for the network is listed in the Introduction.

### **3.2 ThinWire Network Hardware Components**

Figure 3-1 shows the basic cable components of the ThinWire network. Use only DIGITAL ThinWire cable and connectors to install any ThinWire network.

Figure 3-2 shows the cabling diagram for two similar network environments. The procedure for installing each of these is in Paragraphs 3.5.1 and 3.5.2.

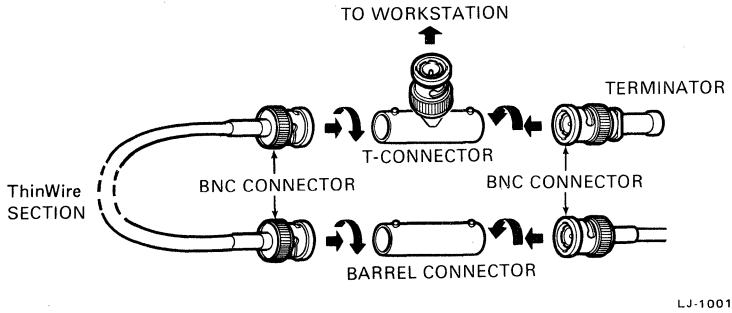

LJ-1001

Figure 3-1 Cable Components

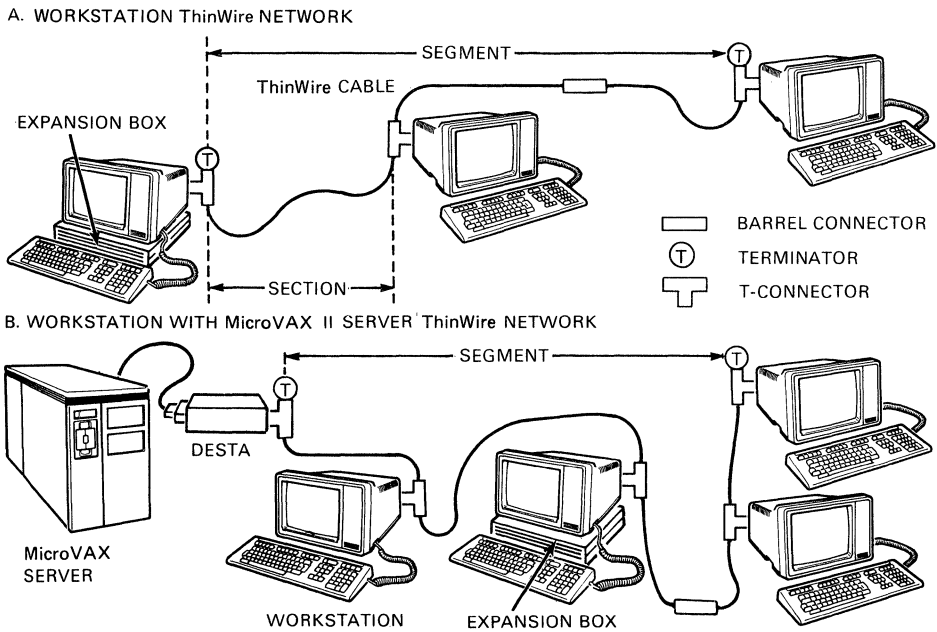

LJ-1016

Figure 3-2 Two Sample ThinWire Networks

### 3.2.1 ThinWire Network Terms

#### **ThinWire Ethernet Cable**

This cable is a thin, flexible, and easy to install coaxial cable. It is fully compatible with standard Ethernet cable. ThinWire cable has a jacket of either Teflon or PVC (polyvinyl chloride). Both Teflon and PVC can be used in an open space such as an office, laboratory, or manufacturing facility.

Teflon-insulated cable is approved by the Underwriters' Laboratory (UL) for safe use in environmental airspace (such as the space between the drop ceiling and the floor above) without placing the cable in a conduit.

PVC-insulated cable, however, is not acceptable for use in environmental airspace that has a return airflow (environmental airspace used for return air from heating and air conditioning systems) because it produces toxic fumes when burned. Therefore, non UL-approved equipment must be placed in a conduit when installing it in a return airspace.

Check local building codes for regulations.

#### **ThinWire Cable Section**

This is a length of ThinWire cable that has BNC connectors at both ends. Sections are available in various lengths.

- 1.9 meters (6 feet)
- 3.8 meters (12 feet)
- 4.4 meters (15 feet)
- 9.4 meters (30 feet)

#### **ThinWire Segment**

This consists of one or more ThinWire cable sections linked together (by barrel or T-connectors). A segment must be terminated at both ends. Another description is that a segment is a run of cable sections between two terminators. The maximum segment length is 185 meters (606 feet). There can be up to 30 stations on each segment -or 60 male/female connections.

#### **T-Connector**

This connector has three connection points - the stem and two arms. A T-connector is used to connect two sections of ThinWire cables (one at each arm of the T) and a workstation (at the stem of the T). If there is a workstation and only one section of ThinWire cable, then the other arm of the T must have a 50-ohm terminator connected to it. The stem of the T must connect directly to the workstation. No cable may be inserted between the stem and the workstation.





**NOTE**

Use T-connectors only when you connect ThinWire cable to workstations or to a DESTA (DIGITAL ThinWire Ethernet Station Adapter).

**Terminator**

A terminator is a resistor that must be installed at each end of a ThinWire segment to electrically complete the circuit. See Figure 3-2. The end of a segment is usually at one arm of a T-connector. A terminator must never connect to the stem of a T-connector.

**Barrel Connector**

This connector has a BNC connector at each end. The barrel connector connects two sections of ThinWire cable.

**BNC Connector**

This connector is a small type N connector used in the ThinWire network. This connector has the characteristic of uniform, low impedance. (BNC stands for Boyonet Neil-Concelman, the inventor).

**DESTA (DIGITAL ThinWire Ethernet Station Adapter)**

A DESTA converts ThinWire Ethernet signals to standard Ethernet signals for addressable devices (nodes), such as a MicroVAX II computer on a network. The DESTA is a direct link between a MicroVAX II server, or other data terminal equipment (DTE) that has a network controller, and a ThinWire network. Refer to the DESTA Technical Description for more information.

**DEMPR (DIGITAL ThinWire Ethernet Multiport Repeater)**

The DEMPR allows the ThinWire network to be expanded to its maximum size.

The DEMPR has eight ports to which eight 185-meter ThinWire cable segments can be connected. Each of the eight DEMPR ports contains a built-in terminator. The DEMPR retimes, amplifies, and repeats all signals it receives from a segment and then transmits the signals to all of the segments connected to the DEMPR.

There is a ninth port on the DEMPR that is used to connect a standard Ethernet transceiver. This logically connects the ThinWire segments to the standard Ethernet.

### DIGITAL Faceplate

The faceplate (Figure 3-3) has four ports for connecting devices to various communication networks.

1. BNC – A ThinWire connector for connecting VAXmate workstations to the ThinWire Ethernet.
2. CATV – An F-connector for connecting video equipment to a cable TV network.
3. MMJ – A Modified Modular Jack for connecting nonintelligent terminals and printers to a twisted pair data communications cable.
4. MJ – A Modular Jack for connecting telephone equipment such as the VAXmate modem cable.

There are two versions of the faceplate; one is mounted on a standard electrical box, the other on a special surface mount wall box. Both versions have four ports.

### Server

This is any network node where there are shared resources. Some server types are compute, disk, application, and print servers. These can be combined on one node.

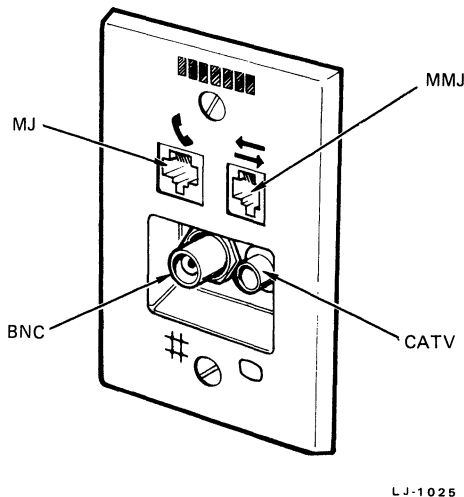

Figure 3-3 DIGITAL Faceplate



### 3.3 ThinWire Network Troubleshooting

Test the ThinWire Network as follows.

1. Make sure all external cabling is firmly plugged in.
2. Run the VAXmate Power-Up Test and the Extended Self-Test. Correct any problems that occur in those tests.
3. Run the VAXmate Service Diagnostics. See Chapter 2, Troubleshooting the VAXmate Workstation. First run the System Test.

Then run the following two Individual Tests. The directions for running these two tests are in Appendix B, Test Descriptions.

09 Network Test

19 Local Network Link Test

These tests check the VAXmate networking hardware and logic, the ThinWire cables, and the cable connections.

4. Test the VAXmate Ethernet controller logic by running the Loop Line Controller Test as follows. You may ask the user to perform the test for you.
  - a. Disconnect the workstation from the network.

**WARNING**

Be careful when you disconnect the VAXmate workstation from the network. See Figure 2-16 for the correct method of doing this.

- b. Install the network port loopback connector. See Figure 2-18.
- c. Ask the user for the key diskette and insert it in the diskette drive.
- d. Let the Power-Up test complete and let the system boot. After about 20 seconds, the screen displays a message stating that the system tried to connect to the server. It also displays an error message stating that the network is busy (NET804 error). These messages occur because the VAXmate workstation is not currently connected to the network.
- e. At the A:\> prompt type: **NTU <Return>**
- f. At the NTU> prompt type: **LOOP LINE CONTROLLER <Return>**

- g. The instructions on the screen are to unplug the network cable from the VAXmate workstation and to plug in the network port loopback connector. However, you have already done this.
- h. Press any key to start the test.
- i. When the test is complete, reconnect the VAXmate workstation to the network.

A successful test means the VAXmate Ethernet logic is functioning correctly. If the test fails, replace the I/O board. Then run the Power-Up test, Extended Self-Test and the Service Diagnostics network tests.

### 3.4 Installation Guidelines

Note the following about ThinWire installations.

- Each VAXmate workstation is shipped with a section of ThinWire cable, a T-connector, and one terminator (50-ohms).
- The maximum length of a Thinwire segment is 185 meters (606 feet). Thirty stations (or up to a combination of 60 male/female connector junctions) can be connected to a single segment. When a DEMPR is used, 29 can be connected to each segment of ThinWire cable – the DEMPR is counted as one connection.
- Stations can be attached directly to the cable segment using T-connectors. T-connectors plug directly into the station.
- There must be at least 0.5 meters (1.6 feet) between ThinWire station connectors.
- A maximum of eight ThinWire segments can be connected to a DEMPR to form a network of up to 232 stations. A DIGITAL Ethernet Local Network Interconnect (DELNI) can be used to concentrate up to eight DEMPRs. These configurations can either stand alone or connect to the standard Ethernet using an H4005 transceiver.
- The Ethernet limit of 1024 devices can be configured in a single ThinWire Ethernet network (using DEMPRs and DELNIs).
- A maximum of 60 connector junctions are allowed in one ThinWire segment. T-connectors and barrel connectors each count as two connector junctions. A DIGITAL faceplate counts as one junction. A DEMPR also counts as one junction.



- When you disconnect a workstation from the network, ALWAYS do so at the stem of the T-connector. See Figure 2-16 for the correct method of disconnecting from the network.

**WARNING**

Disconnecting the T-connector or a terminator from an operating network disrupts the operation of the network.

- Never install a cable at the stem of the T-connector. (Figure 3-4, example B). Example A shows a correct installation.
- Never join two T-connectors or a barrel and a T-connector together. (Figure 3-4, example C).
- Never create a loop configuration. (Figure 3-4, example D). There MUST be a terminator at both ends of a segment (Figure 3-4, example A). Only one end can be a DEMPR.

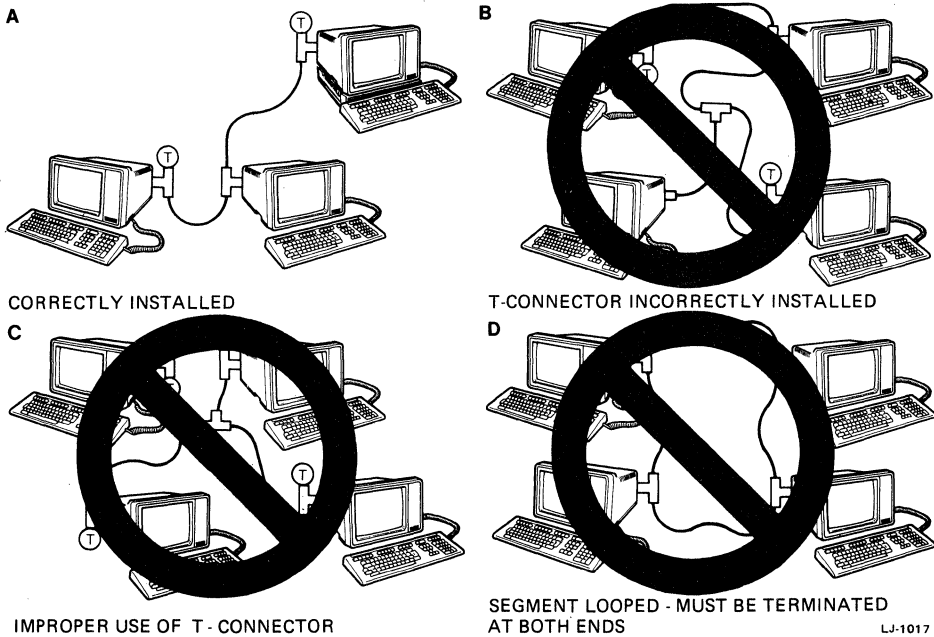

**Figure 3-4 Correct and Incorrect ThinWire Segment Installation**



## 3.5 Installation Procedures

Four typical installation tasks are as follows.

1. Installing a ThinWire network that uses a VAXmate (with expansion box) as the server
2. Installing a ThinWire network that uses a MicroVAX II computer as the server
3. Adding a workstation to the end of an existing ThinWire segment
4. Adding a workstation to the middle of an existing ThinWire segment

Always run the Extended Self-Test on each VAXmate workstation before installing the VAXmate on the network.

### **NOTE**

To install a more complex ThinWire network, see the DECconnect ThinWire Configuration Guide, the DECconnect System Planning and Configuration Guide, and the DECconnect Installation and Verification Guide.

There is also an example of a ThinWire Local Area Network (LAN) in Paragraph 3.6.

When you set up your ThinWire network, write down the total cable length of each section you install. See Paragraph 3.7 for a worksheet and network map to fill out as you install the network.

### 3.5.1 ThinWire Network and VAXmate Server

Figure 3-5 shows a ThinWire network that uses the following components.

- 5 VAXmate workstations (more can be added)
- 1 expansion box (used on the VAXmate workstation that will be the server)
- 2 terminators (50-ohms each)
- 4 sections of ThinWire cable (BNC connectors installed)
- 5 T-connectors

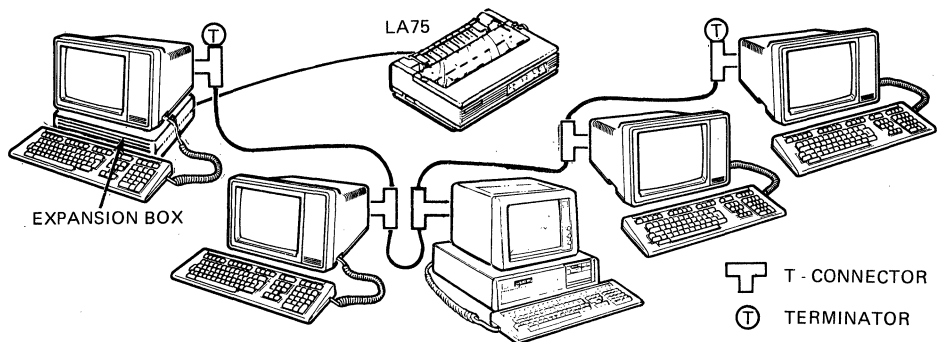

**Figure 3-5 ThinWire Network with a VAXmate Server**

Install the ThinWire network as follows. Also see Figure 3-1 for connector detail.

1. Install the VAXmate (with expansion box) that will be used as the server. See the *VAXmate User's Guide* and the *VAXmate Expansion Box Installation Guide and Owner's Manual* for instructions.
2. Connect the ThinWire cable (with its T-connector and terminator) to the VAXmate workstation. This cable is shipped with the VAXmate workstation.
3. Install the next workstation as follows.
  - a. Prepare the next cable to be attached by removing its terminator from the T-connector. Save the terminator for future use and testing.
  - b. Connect the end of the ThinWire cable of the previously installed VAXmate workstation, to the T-connector of the cable you are now installing.
  - c. Connect the T-connector to the back of the VAXmate workstation you are now installing.Repeat step 3 for each VAXmate workstation to be installed until you are ready to install the final VAXmate workstation on the network.
4. Install the final VAXmate workstation on the network as follows.
  - a. Remove the cable from the T-connector shipped with the final VAXmate workstation. Do not remove the terminator from this T-connector.



- b. Connect the end of the ThinWire cable of the previous VAXmate workstation you installed to the T-connector of the final VAXmate workstation.
  - c. Connect the T-connector to the last VAXmate workstation.
5. Install server software (see the *VAXmate System Administrator's Guide* for instructions).

### 3.5.2 ThinWire Network with MicroVAX II Computer Server

Figure 3-6 shows a ThinWire network that uses the following components.

4 VAXmate workstations (more can be added)

1 expansion box

2 terminators

4 sections of ThinWire cable (BNC connectors installed)

5 T-connectors (you must order one of these, the others are shipped with the VAXmate workstations)

2 printers (with printer cables)

1 MicroVAX II computer

1 DESTA (with DESTA cable)

1 console terminal (with console terminal cable)

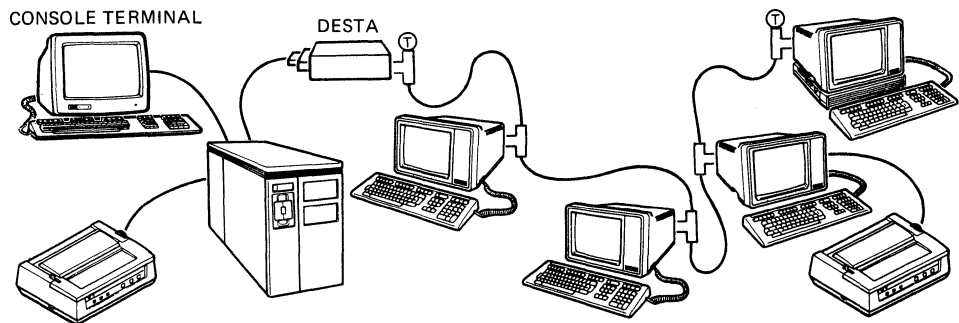

**Figure 3-6 ThinWire Network with MicroVAX II Server**





The console terminal shown in Figure 3-6 is used to install software and run diagnostics. The terminal connects directly to the MicroVAX II server. The printers connect directly to the server and to a workstation. The console terminal and printer are not considered stations on the network.

**NOTE**

The DESTA has a 15-pin cable that connects to the MicroVAX II server. If you are installing a MicroVAX server and only one VAXmate workstation, you must also order a terminator.

Install a ThinWire network with a DESTA and MicroVAX II server as follows. Also see Figure 3-1 for connector details.

1. Install the MicroVAX II computer, console terminal, and the printer.

**CAUTION**

Option boards for the MicroVAX II computer must be installed by an authorized service representative. Dangerous voltages can exist within the computer.

2. Connect the DESTA to the MicroVAX II computer. See the DESTA Installation Card for instructions.
3. Remove the terminator from the T-connector on the ThinWire cable shipped with the first VAXmate workstation to be installed.
4. Connect the terminator to the T-connector that is to be used on the DESTA. (This T-connector has no ThinWire cable attached.)
5. Connect the T-connector to the DESTA.
6. Connect the end of the ThinWire cable shipped with the first VAXmate workstation to be installed to the T-connector on the DESTA.
7. Connect the ThinWire cable with its T-connector to the VAXmate workstation.
8. Remove the terminator from the T-connector on the ThinWire cable shipped with the next VAXmate workstation to be installed on the network. Save the terminator for future use and testing.
9. Connect the end of the ThinWire cable to the T-connector on the VAXmate workstation you just installed on the network.
10. Connect the T-connector to the next VAXmate workstation to be installed.



11. Repeat steps 7, 8, 9, and 10 for each VAXmate workstation to be installed until you are ready to install the last VAXmate workstation on the network.
12. Connect the end of the ThinWire cable (shipped with the last VAXmate workstation to be installed) to the T-connector on the VAXmate workstation you just installed on the network. Do not remove the terminator from this cable.
13. Connect the T-connector to the last VAXmate workstation to be installed.
14. Inform the System Administrator that the network is available.
15. Install the VAX/VMS server software (see the VAXmate System Administrator's Guide for instructions).

### 3.5.3 Adding a Workstation to End of ThinWire Segment

Add a VAXmate workstation to an existing segment as follows (Figure 3-7).

#### **NOTE**

This procedure shuts down the network operation on the segment. Inform all users. Get permission from the System Administrator.

1. Inform all users that the network will be shut down.
2. Remove the terminator from the last workstation on the segment.

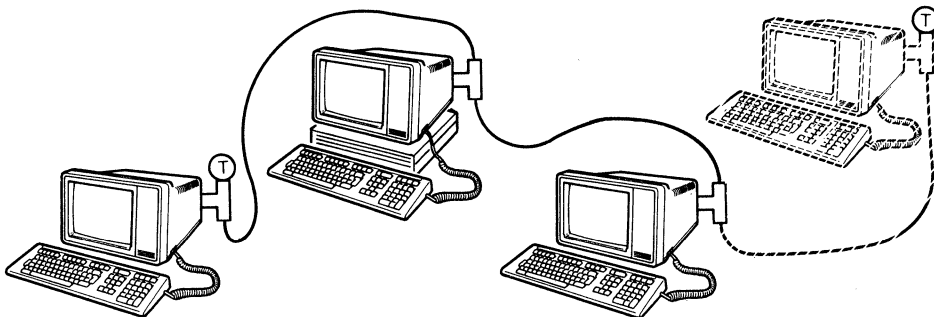

LJ-1021

**Figure 3-7 Adding a VAXmate Workstation to End of Existing Segment**



3. Connect the end of the ThinWire cable shipped with the new VAXmate workstation to the T-connector on the last VAXmate workstation. Do not remove the terminator from this cable.
4. Connect the T-connector to the new VAXmate workstation. Make sure all connections are secure.
5. Inform the System Administrator that the network is available.

### **3.5.4 Adding a VAXmate Workstation to Middle of an Existing Segment**

Add a VAXmate workstation in the middle of an existing segment as follows (Figure 3-8).

**NOTE**

This procedure shuts down the network operation on the segment.

1. Inform all users that the network will be shut down.
2. Remove the terminator and cable from the ThinWire cable shipped with the new VAXmate workstation.

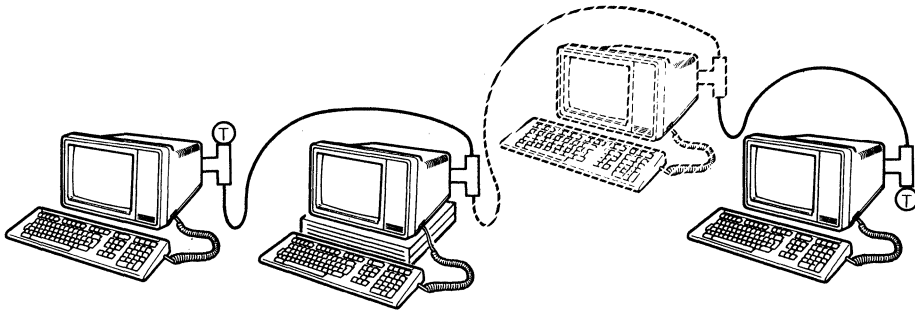

LJ-1022

**Figure 3-8 Adding a VAXmate Workstation to Middle of an Existing Segment**

3. Connect the T-connector to the new VAXmate workstation.
4. Remove the ThinWire cable from the T-connector on one adjacent VAXmate workstation.
5. Connect the ThinWire cable to one side of the T-connector on the new VAXmate workstation.



6. Connect the ThinWire cable from the T-connector on the other adjacent VAXmate workstation.
7. Connect the ThinWire cable to other side of the T-connector on the new VAXmate workstation. Make sure all connections are secure.
8. Inform all users that the network is available.

### 3.6 ThinWire Local Area Network (LAN) Example

Figure 3-9 shows how a DEMPR can be used to create a ThinWire LAN. The DEMPR has eight ThinWire network ports – four segments are connected in Figure 3-9. Each segment can be 185 meters long.

Notice that each segment follows the installation guidelines.

For more information about using a DEMPR configuration to build a wider area network, see the list of related documents in the Introduction.

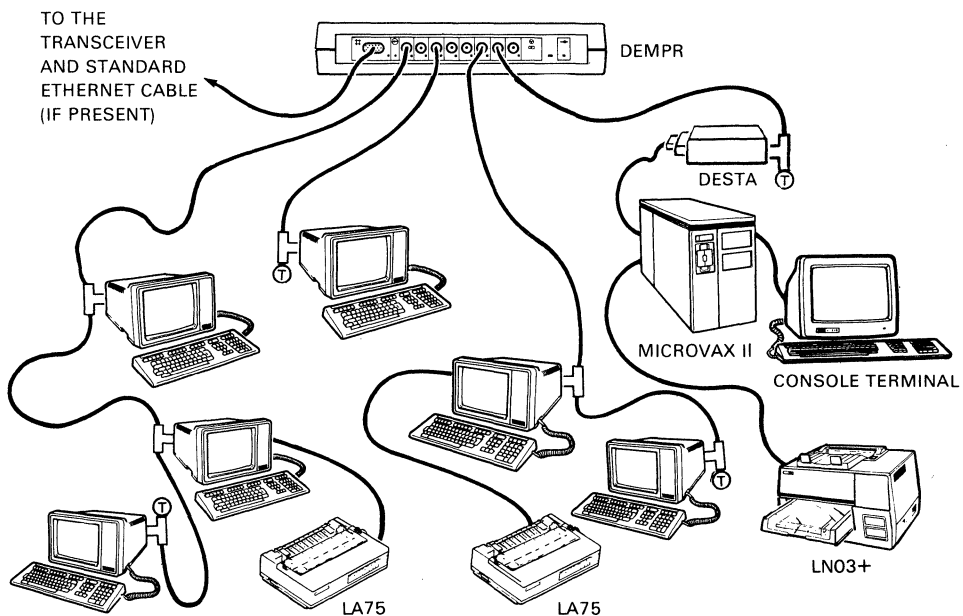

LJ-0907

**Figure 3-9 Sample ThinWire LAN**



### **3.7 ThinWire Network Map and Worksheet**

The System Administrator has a configuration map of the network. Use the map to determine the following information.

- Devices on the network
- Lengths for each ThinWire cable section per segment
- Number of connections per segment

The worksheet identifies devices and users on the network. You can help the System Administrator in filling out the following worksheet.

| Node Name | Alias | Logical Name | Office Location | Contact Person | Telephone Number |
|-----------|-------|--------------|-----------------|----------------|------------------|
|           |       |              |                 |                |                  |
|           |       |              |                 |                |                  |
|           |       |              |                 |                |                  |
|           |       |              |                 |                |                  |
|           |       |              |                 |                |                  |
|           |       |              |                 |                |                  |
|           |       |              |                 |                |                  |
|           |       |              |                 |                |                  |
|           |       |              |                 |                |                  |
|           |       |              |                 |                |                  |
|           |       |              |                 |                |                  |
|           |       |              |                 |                |                  |
|           |       |              |                 |                |                  |
|           |       |              |                 |                |                  |
|           |       |              |                 |                |                  |
|           |       |              |                 |                |                  |
|           |       |              |                 |                |                  |

# *Chapter 4*

## *Monitor Adjustments*

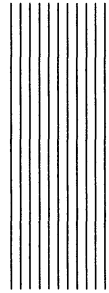

### 4.1 Introduction

This chapter describes general adjustment procedures for the monochrome monitor assembly. For several of the adjustment procedures, you need a DIGITAL metric tape measure (p/n 29-25342).

Before making any adjustments do the following steps.

1. Turn off the VAXmate workstation power.
2. Insert the Service Diagnostics in the drive, push the latch down to lock in the diskette, and close the drive door.
3. Turn on the VAXmate workstation power. Allow the Power-Up test to complete.
4. Let the system stabilize for five minutes. If there is no video display, increase the brightness to make sure the raster is displayed. See Paragraph 4-2. If there is no raster see Table 2-2, Symptoms.
5. At the Main Diagnostic Menu, select option 2, individual tests.
6. At the Individual Test Menu, select option 13, Video Alignment Patterns.
7. At the Individual Test Option Menu, press the **Return** key for the default selections.
8. Start the adjustment procedures. If it is necessary to make adjustments, remove the system unit back door and cover. The procedure for doing this is in Chapter 5, Paragraphs 5.3.5 and 5.3.6.



## 4.2 Brightness and Contrast Adjustment

The brightness control sets the current flow through the control grid (G1) of the CRT. If set too high, the entire grid is displayed on the screen. The contrast control adjusts the brightness of the characters and lines by controlling the current through the video amplifier circuit. To check these settings:

1. Select pattern number 5. Check for 15 distinct bars increasing in intensity from left to right across the screen.
2. If all bars are not present, adjust the brightness and contrast controls (Figure 4-1).

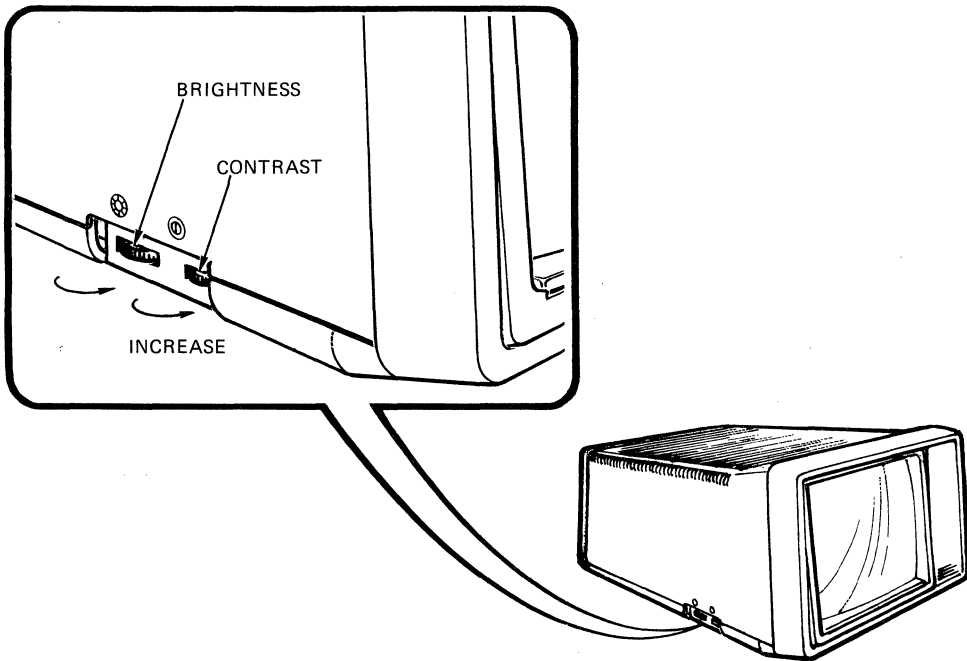

LJ-0908

**Figure 4-1 Brightness and Contrast Controls**

3. If all bars are still not present, there is a problem with either the monitor board or I/O board. Replace the monitor board and return to Paragraph 4.1 for testing. (See Chapter 5 for FRU replacement.)
4. If all bars are still not present, replace the I/O board and return to Paragraph 4.1 for testing.



### 4.3 Internal Monitor Adjustments

To make many of the internal adjustments, remove the system unit back door and cover. The procedures for removing the back door and cover are in Chapter 5, Paragraphs 5.3.5 and 5.3.6.

Table 4-1 lists the symptoms and the corresponding adjustment to correct the problem. If an adjustment cannot be made satisfactorily, replace the monitor board. If the adjustment still can't be made satisfactorily, replace the CRT. However, remember to install the original monitor board. When installing a new monitor board or CRT, perform the adjustments in the order listed in this table.

**Table 4-1 Adjustments, Patterns, and Control Locations**

| Symptom                  | Adjust          | Align Pattern | Loc.            | Etch Label | Para. Ref. |
|--------------------------|-----------------|---------------|-----------------|------------|------------|
| 1 Dark screen            | Bright/contrast | 5             | Side of monitor |            | 4.2        |
| 2 Horiz movement         | Horiz hold      | 6             | Monitor board   | HH         | 4.3.1      |
| 3 Retrace lines          | Cutoff          | 6             | Monitor board   | G2         | 4.3.2      |
| 4 Screen narrow          | Width coil      | 6             | Monitor board   | W          | 4.3.3      |
| 5 Screen height 400 mode | Height 400      | 6             | Monitor board   | H4         | 4.3.4      |
| 6 Screen not centered    | Centering rings | 6             | Yoke rings      |            | 4.3.5      |
| 7 Screen slanted         | Rotation        | 6             | Yoke collar     |            | 4.3.6      |
| 8 Bright edges           | Video comp      | 6             | Monitor board   | VC         | 4.3.7      |
| 9 Screen height 250 mode | Height 250      | 7             | Monitor board   | H2         | 4.3.8      |
| 10 Out of focus          | Focus           | 6 (or 8)      | Monitor board   | F          | 4.3.9      |





## Monitor Adjustments

Figure 4-2 shows the monitor board controls and their label names. They may be in slightly different locations than on the monitor board you have, because the monitor board versions are different. However, they do function identically.

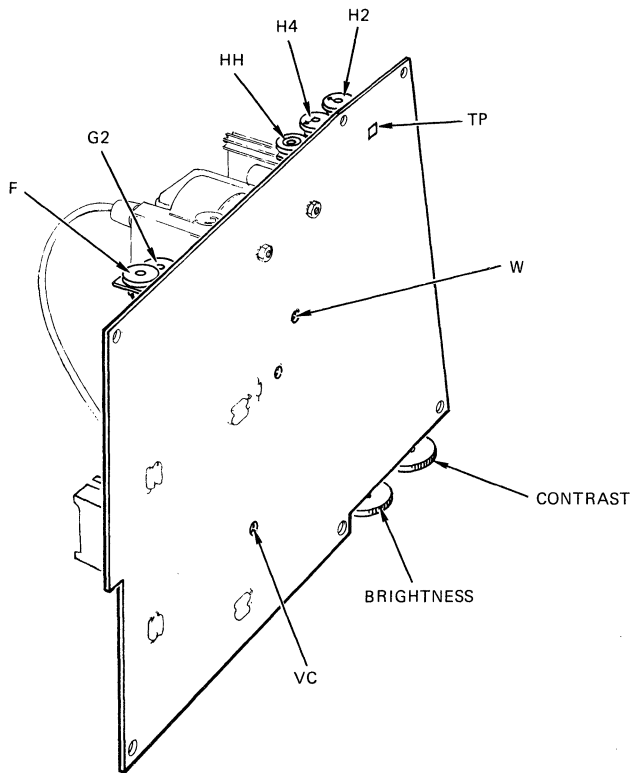

LJ-0909

**Figure 4-2 Monitor Board Controls**



### 4.3.1 Horizontal Hold

The horizontal hold control adjusts the output of the line oscillator. Horizontal hold should not have to be adjusted because the control is preset and sealed at the factory. However, if the control was inadvertently moved, use the following procedure to adjust horizontal hold.

1. Display pattern 6, screen of E's (400 line mode).
2. Connect the clip lead of the anode discharge tool to chassis ground.
3. Use the probe tip of the tool to touch the square of etch labeled TP. See Figure 4-3.
4. Adjust the horizontal hold (HH) control until the picture slowly moves in either direction across the screen.
5. When the probe tip is removed, the picture should immediately lock-in.

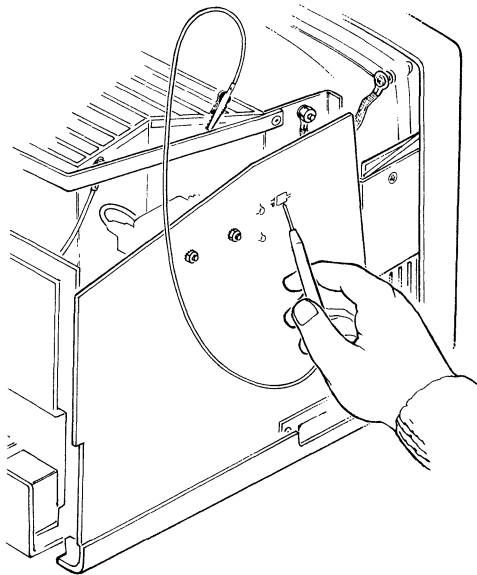

LJ 0010

**Figure 4-3 Horizontal Hold**



### 4.3.2 Cutoff

The cutoff control sets the threshold of the accelerator grid (G2) of the CRT. If set too high, retrace lines are displayed on the screen. Display pattern 6 (the 400 line mode screen of E's) and follow these next steps to adjust cutoff control.

1. Set the brightness control to maximum and contrast control to minimum. See Figure 4-1.
2. Adjust the cutoff control (G2) (see Figure 4-2) so the raster is just barely visible (almost at extinction).
3. Turn G2 clockwise about 30 to 45 degrees (Figure 4-4). The display brightens. There should be no retrace lines visible. If you still see the retrace lines, replace the monitor board.
4. Return the brightness and contrast controls to normal settings.

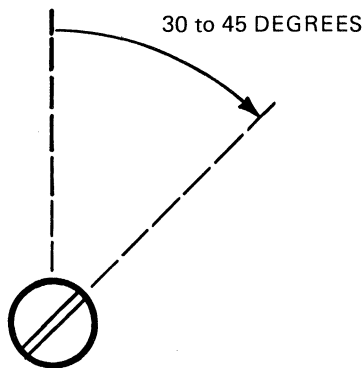

G2 CONTROL ON MONITOR BOARD

LJ-0911

**Figure 4-4 Cutoff Adjustment**



### 4.3.3 Width Coil

The width coil (W) adjusts the width of the line sweep across the screen. Display pattern 6, and use the metric tape measure to adjust width. Follow these next steps.

1. Move the keyboard aside to avoid accidentally pressing a key. If you accidentally press a key, causing the display to blank, you will have to restart the Service Diagnostics.
2. Measure the width, at the center of the screen, from the outer edge of the left border to the outer edge of the right border. See Figure 4-5. The distance should be 240 mm ( $\pm 2$  mm).
3. If necessary, adjust the width coil (W). See Figure 4-2.

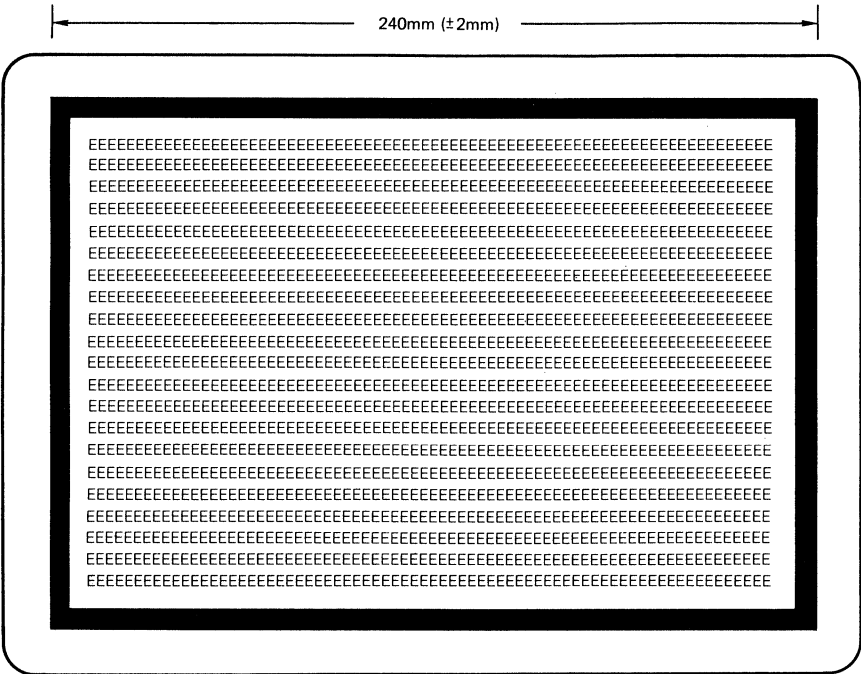

LJ-0912

Figure 4-5 Width Measurement



### 4.3.4 Height – 400 Line Mode

This control sets the amplitude of the ramp signal to the field deflection circuit to blank the screen at the correct height in 400 line mode. To adjust the height do the following steps.

1. Display pattern 6, the 400 line mode screen of E's.
2. Measure the height at the center of the screen from the outer edge of the top border to the outer edge of the bottom border. See Figure 4-6. The distance should be 150 mm ( $\pm 2$  mm) in 400 line mode.
3. If necessary, adjust the 400 line height control (H4).

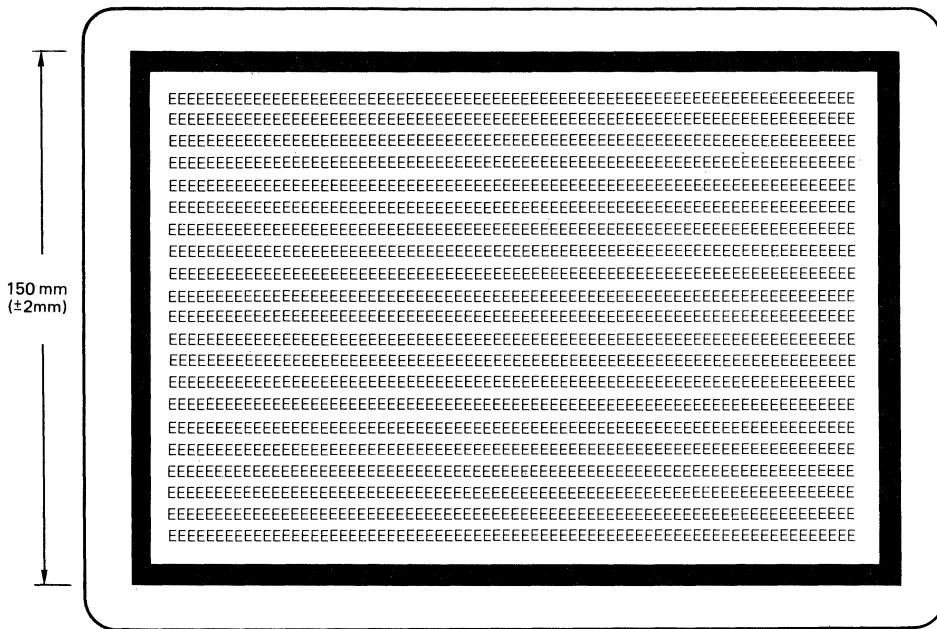

LJ-0913

Figure 4-6 Height Measurement

### 4.3.5 Centering Rings

This procedure adjusts the yoke centering rings. Follow these steps and see Figure 4-7.

1. Display pattern 6, the 400 line mode screen of E's.
2. Measure the distance from the left border's outer edge to the left bezel's inner edge (a).
3. Then, measure the distance from the right border's outer edge to the right bezel's inner edge (b). The difference (b - a) should be less than 2 mm.
4. Measure the distance from the top border's outer edge to the top bezel's inner edge (c).
5. Then, measure the distance from the bottom border's outer edge to the bottom bezel's inner edge (d). The difference (d - c) should also be less than 2 mm.

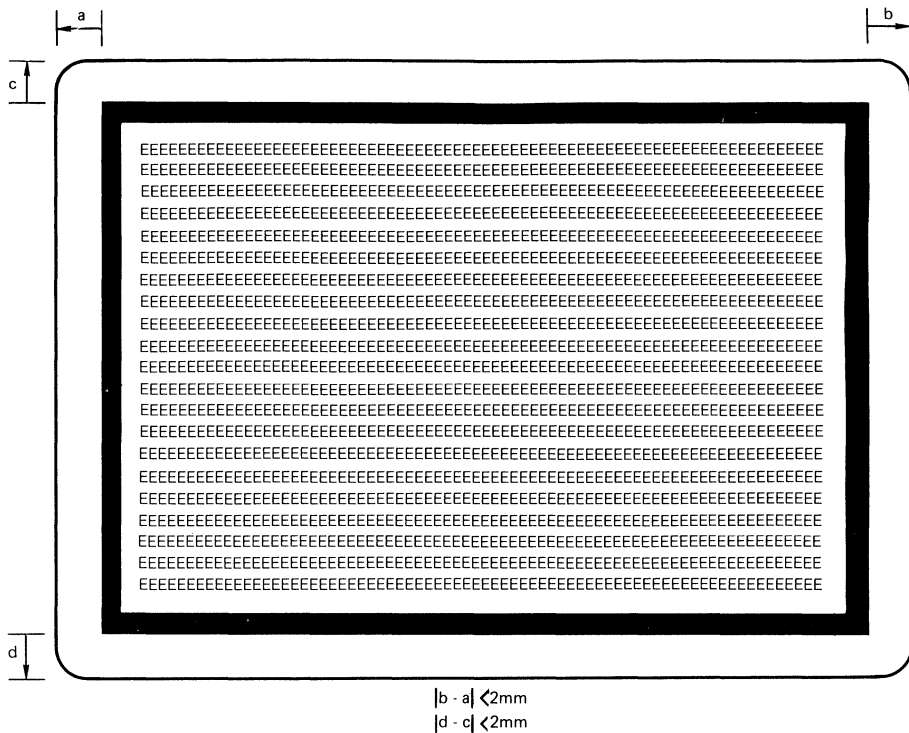

**Figure 4-7 Centering Measurement**

LJ-0914



**WARNING**

High voltages exist in this area. Make sure to remove jewelry before adjusting the centering rings.

6. To center the picture to within the 2 mm tolerances, adjust the centering rings on the yoke as shown in Figure 4-8. Use the tilt screen mechanism to position the CRT screen at its lowest position. This causes the yoke to be at its highest position thereby making it easier to access the centering rings.

It may be necessary at this point to readjust the width and height.

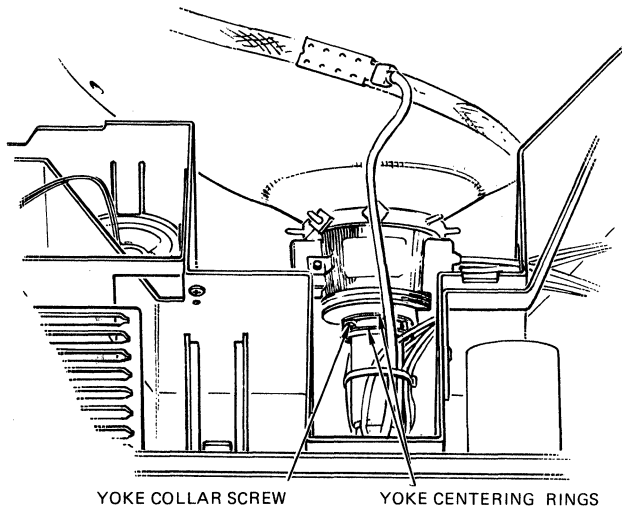

LJ-0915

**Figure 4-8 Yoke Centering Rings**



### 4.3.6 Rotation

This procedure adjusts the yoke collar to compensate for a rotated (slanted) display. Check the rotation as follows.

1. Display pattern 6, the 400 line mode screen of E's and Figure 4-9.
2. Measure the distance between the bottom edge of the border and the bezel – take three different measurement readings along this line.
3. Compare the results. If the difference between any of the measurements is greater than  $\pm 2$  mm, then follow these steps.

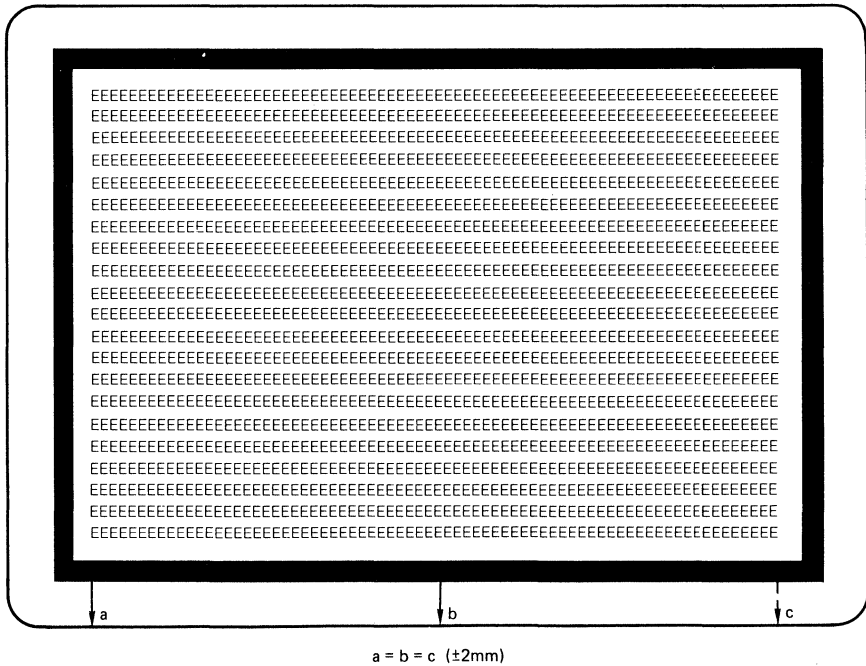

LJ-0916

**Figure 4-9 Rotation Measurement**





**WARNING**

High voltages exist in this area. Remove jewelry before loosening the screw.

- a. Loosen the yoke clamp screw on the collar that secures the yoke to the neck of the CRT. See Figure 4-8.
- b. Turn the yoke to adjust a rotated (slanted) display.

**NOTE**

As you make the adjustment, make sure the yoke is pushed toward the front of the CRT (keep it from slipping back). Otherwise, the geometry of the display is affected.

- c. Tighten the screw while you hold the yoke pushed firmly toward the front of the CRT.

If the screen is curved or bowed by more than 2 mm at the top, bottom or sides, replace the CRT – bowing cannot be adjusted.

### **4.3.7 Video Compensation**

The video compensation control, at the video amplifier output, compensates for the capacitance of the CRT. Make this adjustment as follows.

1. Display pattern 6, the 400 line mode screen of E's.
2. Set the contrast control to maximum, then reverse the direction  $1/4$  turn.
3. Set the brightness control to as low a setting that allows the picture to be viewed.
4. Turn the video compensation (VC) control fully counterclockwise (from the etch side) until it stops.
5. Look for the intensified lines (transition from dark to light) at the inside edge of the right border.
6. Turn the VC control clockwise until the line just disappears.
7. Return the brightness and contrast controls to normal settings.



### 4.3.8 Height – 250 Line Mode

This control sets the amplitude of the ramp signal to the field deflection circuit to blank the screen at the correct height during 250 line mode. Adjust the height as follows.

1. Display pattern 7, the 250 line mode screen of E's.
2. Measure the height at the center of the screen from the outer edge of the top border to the outer edge of the bottom border. See Figure 4-6. The distance should be 150 mm ( $\pm 2$  mm).
3. If necessary, adjust the 250 line height control (H2) and measure the height again.

### 4.3.9 Focus

The focus control adjusts the current through the focus grid (G3) on the CRT. Adjust the focus as follows.

1. Display pattern 6, the 400 line mode screen of E's, or 8, the Grid/Circle.
2. Examine the pattern at the four corners and in the center of the screen. Each line should be sharp and well-defined.



# ***Chapter 5*** ***FRU Replacement***

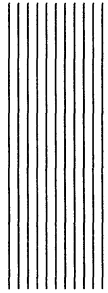

## **5.1 Introduction**

This chapter describes how to remove and replace each VAXmate field replaceable unit (FRU). Only qualified service technicians should remove and replace FRUs.

Table 5-1 lists each FRU and the paragraph numbers of the corresponding removal or replacement procedures. To install many of the FRUs, you can simply do the reverse of the removal procedure.



**Table 5-1 FRUs and Removal/Replacement Procedures Paragraph Numbers**

| <b>FRU</b>                      | <b>Paragraph Number</b> |
|---------------------------------|-------------------------|
| System Unit                     |                         |
| Fuse                            | 5.3.3                   |
| 2 Mbyte memory option           | 5.3.7                   |
| Modem option                    | 5.3.8                   |
| Math coprocessor option (80287) | 5.3.9                   |
| Speaker                         | 5.3.10                  |
| Monitor board                   | 5.3.11                  |
| CRT (monochrome)                | 5.3.13                  |
| Diskette drive                  | 5.3.15                  |
| CPU board                       | 5.3.17                  |
| Power LED assembly              | 5.3.19                  |
| I/O-video board                 | 5.3.21                  |
| Power supply board              | 5.3.23                  |
| Expansion Box                   | 5.3.2                   |
| Hard disk subsystem             | 5.3.25                  |
| Hard disk drive                 |                         |
| Read/write board                | 5.3.28                  |
| Hard disk controller board      | 5.3.33                  |
| Option boards                   | 5.3.34                  |
| Option backplane                | 5.3.35                  |
| Fan assembly                    | 5.3.36                  |
| Power connector and bridge      | 5.3.37                  |
| Power regulator board           | 5.3.38                  |
| Battery for event timer         | 5.3.39                  |
| Keyboard                        | 5.3.40                  |
| Mouse                           | 5.3.41                  |



## 5.2 Before You Replace Any FRUs

The following rules apply when you are removing or installing VAXmate FRUs.

- You must always turn off the power and unplug all external cables before you remove any FRUs (Paragraph 5.3.1).

### **WARNING**

When disconnecting the network cable, always follow the procedure shown in Figure 2-16. Do not disconnect the T-connector at the terminator or cable. Always disconnect the T-connector from the VAXmate workstation.

- Always use a grounded wrist strap and grounded work surface when you open the system unit or expansion box, or handle any internal components. Static electricity can damage printed circuit boards and mass storage devices.
- After you replace an FRU, make sure to run the Power-up test, the Extended Self-Test, and the Service Diagnostics' System test. If you replace the 2 Mbyte memory, the modem, or any FRU in the Expansion Box, also make sure to run the individual test for that component.

These tests verify that the new component functions correctly and also report any additional errors.

- Whenever the expansion box is separated from the system unit the event timer stops. The event timer, located in the system unit, receives power from the battery, located in the expansion box. Therefore, when you attach the expansion box to the system unit, you should run the Extended Self-Test to check the system configuration.

### **NOTE**

Set the power switch to off and wait 15 seconds for the hard disk to stop spinning. Set the power switch to on and let the power up test complete. Then, run the Extended Self-Test.



## 5.3 Replacing FRUs

### 5.3.1 Turning Off Power and Unplugging External Cables

1. Turn off power to the VAXmate system and unplug all external cables (Figure 5-1).
2. If an expansion box is attached to the VAXmate workstation, unplug any cables present (Figure 5-1).

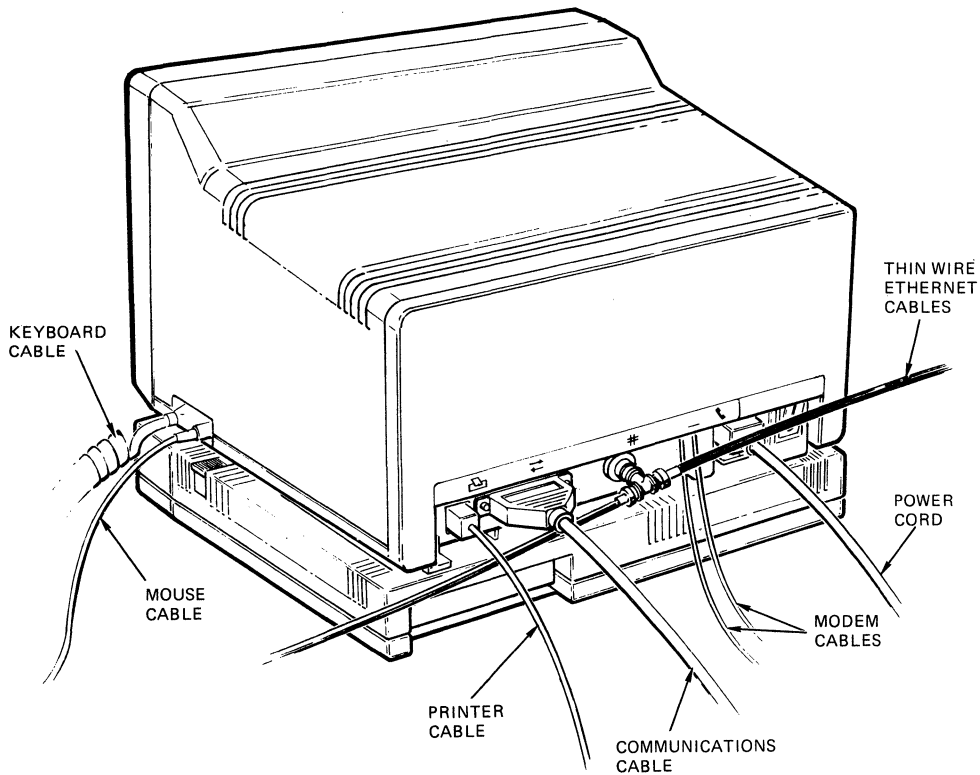

**Figure 5-1 Cable Locations**

LJ-0917



### 5.3.2 Separating the Expansion Box from the System Unit

1. Unplug all external cables (Paragraph 5.3.1).
2. Release the three locks in the locations shown (Figure 5-2).
3. Lift the system unit straight up. The unit is heavier toward the screen.

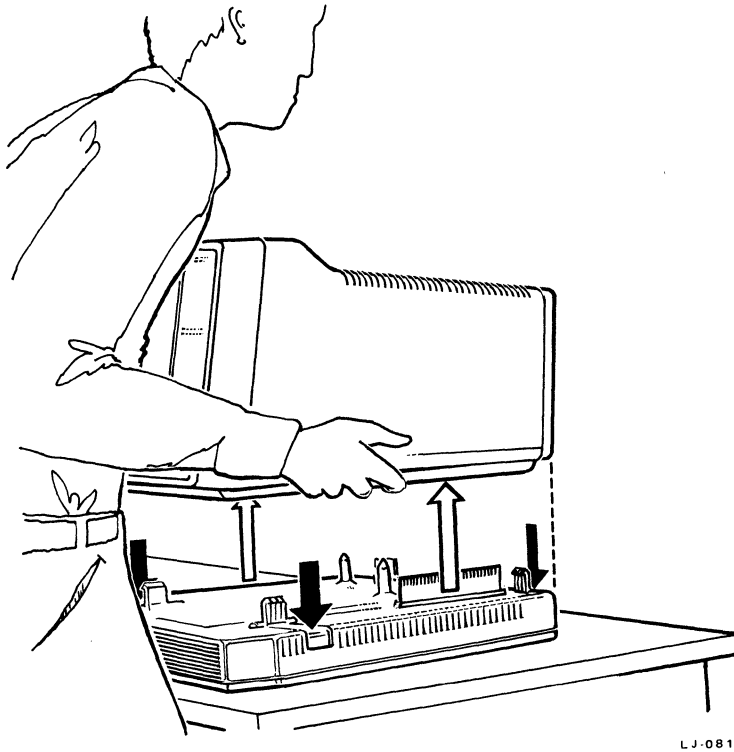

**Figure 5-2 Separating the Expansion Box from the System Unit**





### 5.3.3 Fuse Replacement

The VAXmate workstation fuse is under the system unit. The expansion box does not have a fuse.

1. Unplug all external cables (Paragraph 5.3.1).
2. If attached, separate the expansion box from the system unit (Paragraph 5.3.2).
3. Gently tip the system unit on its left side.

**CAUTION**

Do not tip the system unit on its back or front. The back door, CRT screen, or drive door may get damaged.

4. Replace the fuse (Figure 5-3).
5. Return the VAXmate workstation to its normal position.

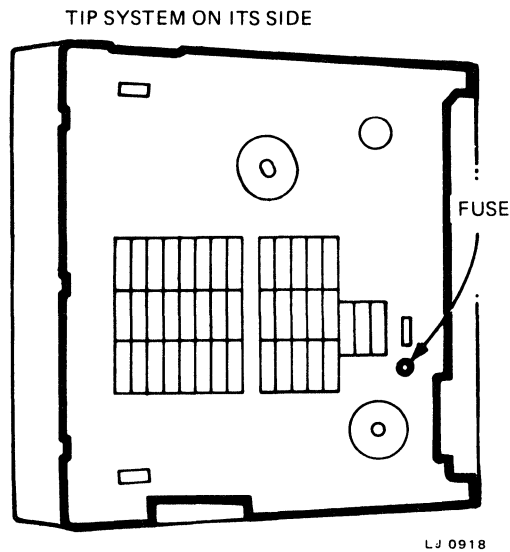

**Figure 5-3 Fuse Location**



### 5.3.4 Opening the System Unit Back Door

1. Unplug all external cables (Paragraph 5.3.1).
2. Press the power cord latch and pull the door open (Figure 5-4).

**NOTE**

The back door does not open flat. Do not lean on or apply any weight to an open back door.

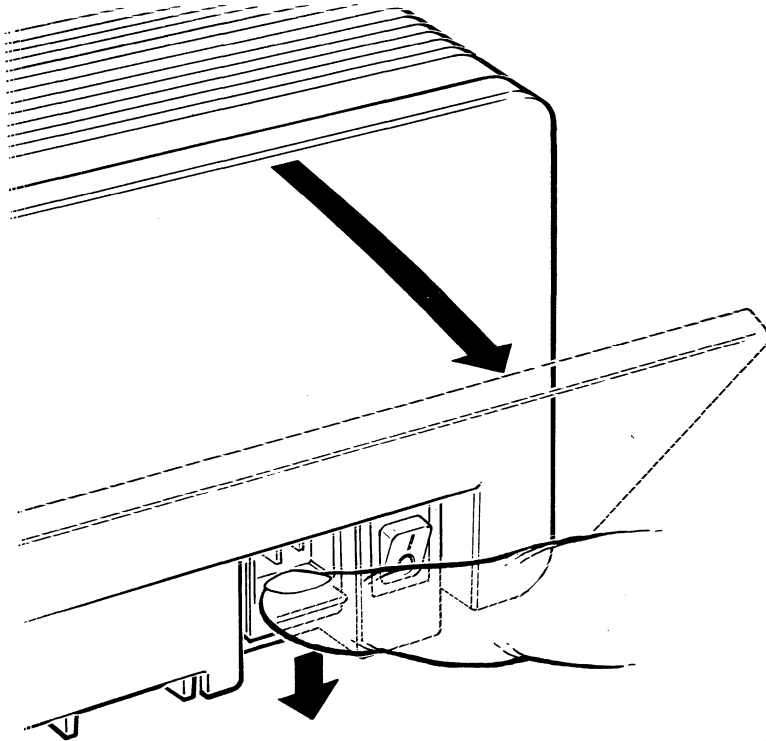

LJ-0726

**Figure 5-4 Opening the Back Door**



### 5.3.5 System Unit Back Door Removal

1. Unplug all external cables (Paragraph 5.3.1).
2. Open the back door (Paragraph 5.3.4).

**NOTE**

The back door does not open flat. The door is shown flat for clarity.

3. Remove the two back door screws (Figure 5-5).

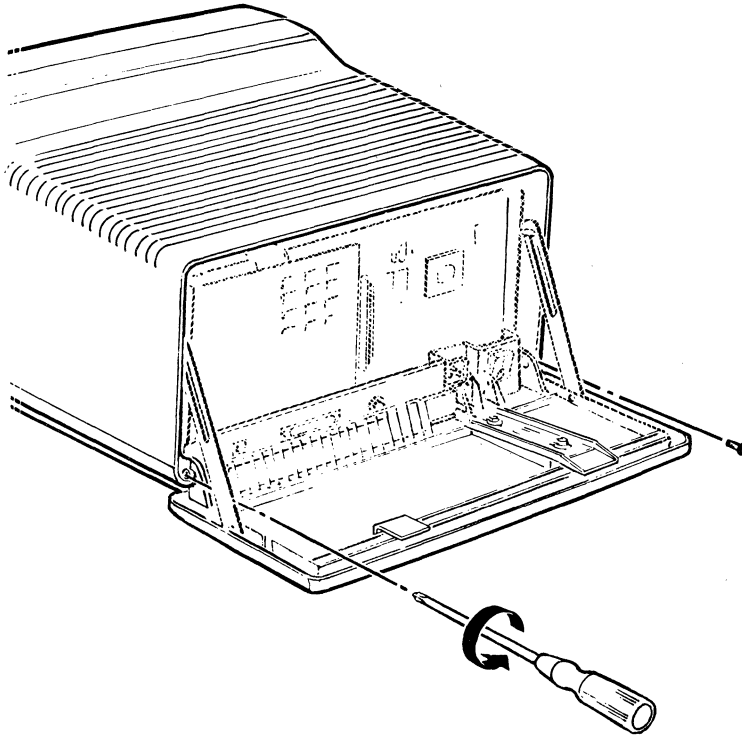

LJ-0727

**Figure 5-5 Removing the Back Door Screws**



4. Swing the door up and align the restraining bars (links) with the plastic tabs (Figure 5-6).

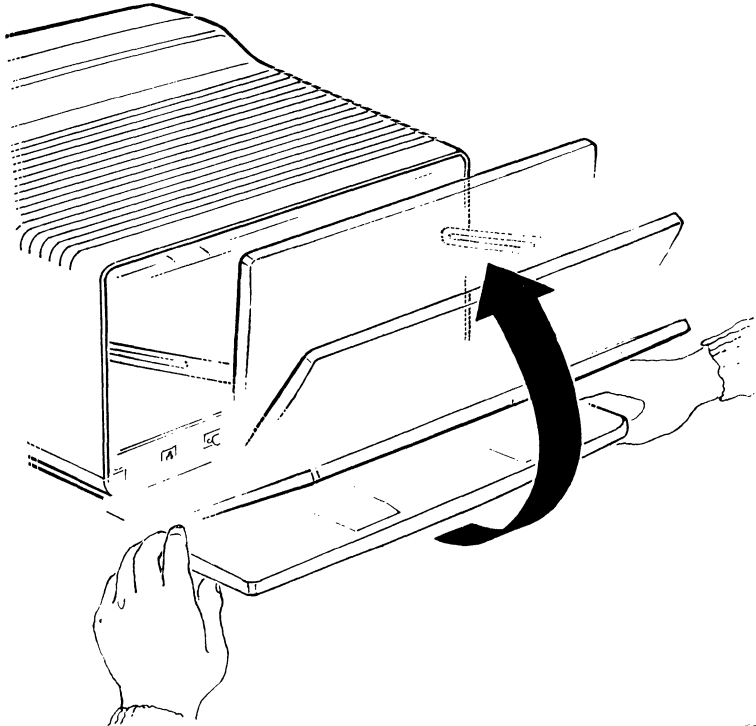

LJ-0728

**Figure 5-6 Swinging the Door Up**



5. Release the links from the tabs and remove the door (Figure 5-7).
- To install the back door, do the reverse of steps 1 through 5.

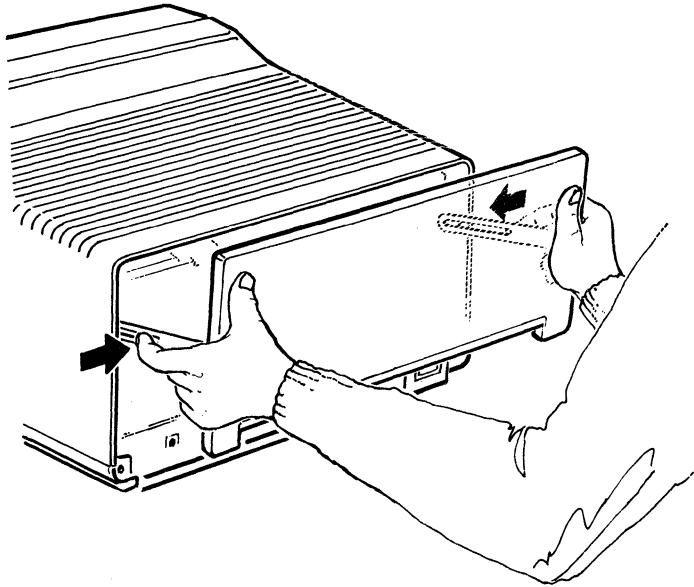

LJ-0729

**Figure 5-7 Releasing the Links to Remove the Door**



### 5.3.6 System Unit Cover Removal

1. Remove the back door (Paragraph 5.3.5).
2. Press the three latches on the cover with a thin-bladed tool, such as a screwdriver (Figure 5-8). Be careful not to scratch the top of the VAXmate workstation.
3. Lift the cover away from the unit (Figure 5-8).

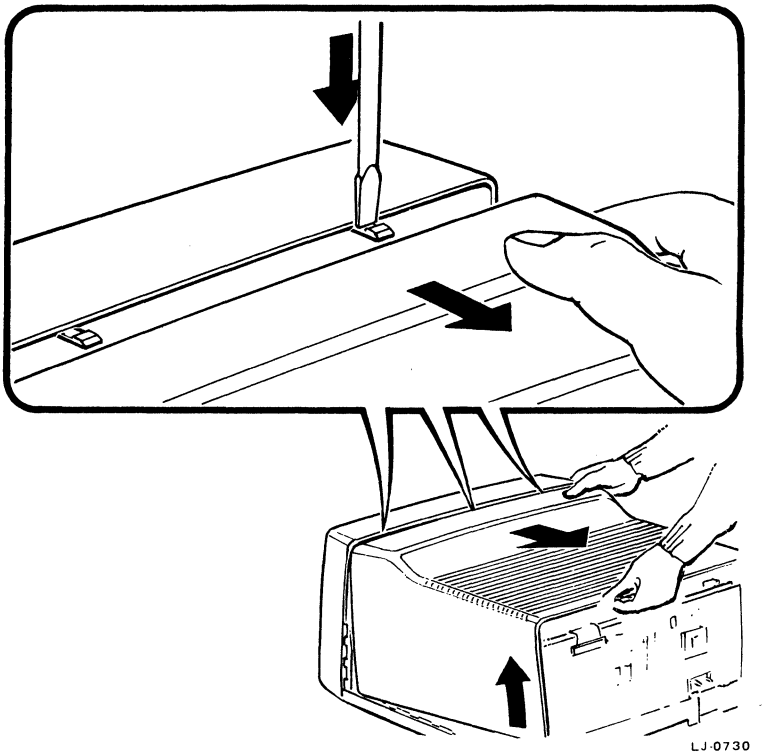

**Figure 5-8 Removing the Cover**



4. Note the location of the boards (Figure 5-9).
5. To install the system unit cover, do the reverse of steps 1 through 4.

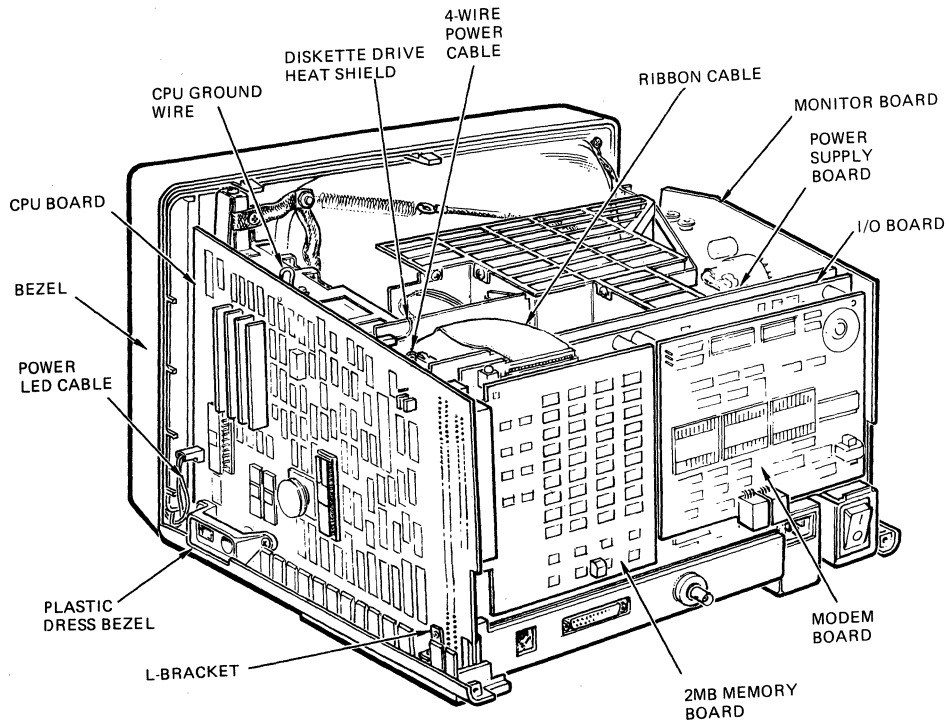

**Figure 5-9 Board Locations**

LJ-1468

### 5.3.7 Two Mbyte Memory Replacement

1. Open the back door of the system unit (Paragraph 5.3.4). You do not have to remove the back door.
2. Remove the faulty memory board (Figure 5-10).
3. Install the new memory board.

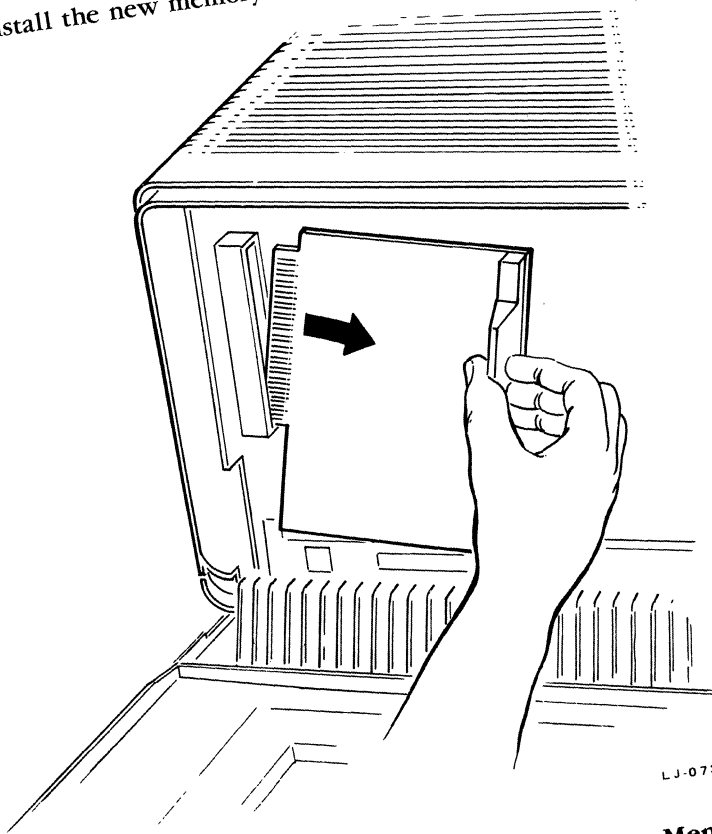

Figure 5-10 Removing the 2 Mbyte Memory Board





### 5.3.8 Modem Board Replacement

1. Separate the expansion box, if present, from the system unit (Paragraph 5.3.2). Although you can gain access to the modem board without separating the two units, you must separate the units to test the new modem.
2. Open the back door of the system unit (Paragraph 5.3.4). You do not have to remove the back door.
3. If the 2 Mbyte memory board is present, remove it (Paragraph 5.3.7).
4. Release the modem board standoff and remove the faulty modem board (Figure 5-11).

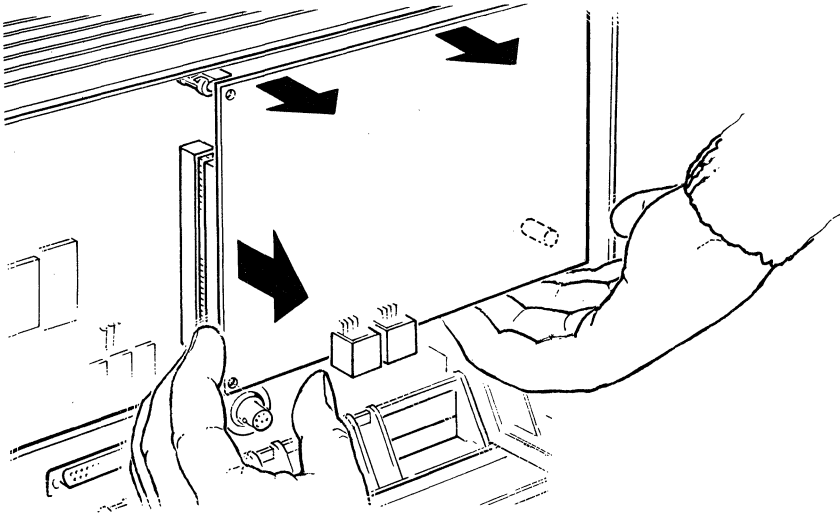

LJ-0920

**Figure 5-11 Removing the Modem Board**



5. Set the jumper on the new modem board to pins 2 and 3. If an industry standard option is present, set the jumper to pins 1 and 2 (Figure 5-12).
6. Install the new modem board.
7. If you removed a 2 Mbyte memory board, reinstall it now.
8. Close the back door and plug in all cables.

To test the new modem board, run Individual Test 17, Modem Tests.

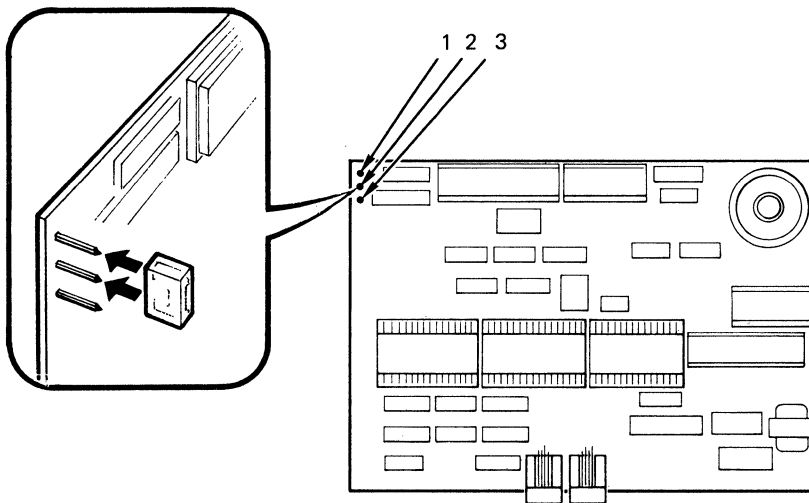

LJ-0921

**Figure 5-12 Modem Board Jumper Locations**



### 5.3.9 Math Coprocessor (80287) Replacement

1. Remove the system unit back door (Paragraph 5.3.5) and cover (Paragraph 5.3.6).
2. Remove the 80287 coprocessor by using the chip removal tool. Be careful not to damage the socket. Figure 5-13 shows the location of the 80287 coprocessor.

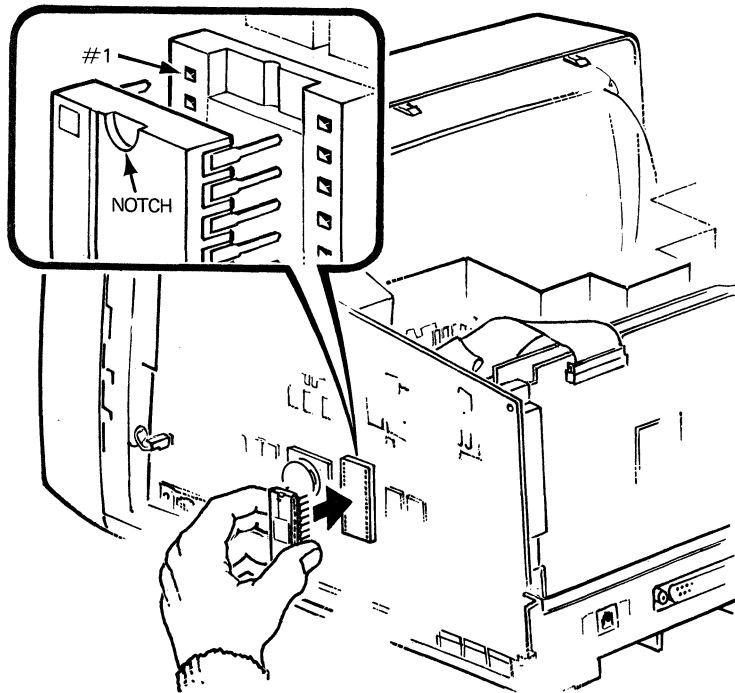
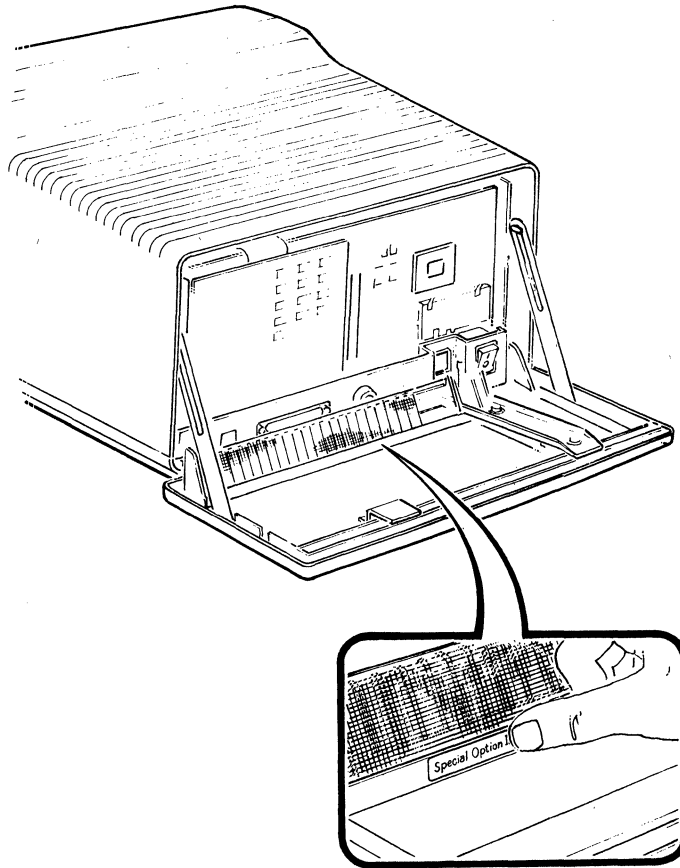

Figure 5-13 Installing the 80287 Coprocessor LJ-0731



3. Install the new 80287 coprocessor. Make sure the notched end of the chip is at the top and that you align the number 1 pin with the number 1 hole. Be careful not to bend the pins.
4. Install the cover and door.
5. Place the “Special Option Installed” label (p/n 36-23792-01) on the door (Figure 5-14).



LJ-0736

**Figure 5-14 Special Option Installed Label**



### **5.3.10 Speaker Replacement**

1. Remove the system unit back door (Paragraph 5.3.5) and cover (Paragraph 5.3.6).
2. Detach the speaker cable from the CPU board (Figure 5-15).
3. Loosen, but do not remove, the screw holding the diskette drive heat shield to the CRT shield.
4. Lift out the heat shield. It rests in tab slots (Figure 5-15).
5. Press the speaker retainer tab with your thumb and slide the speaker out (Figure 5-15). Do not lift the speaker out by the wire.
6. Install the new speaker.
7. When installing the heat shield put the extension tab (if present) on the heat shield into the slot in the top of the diskette drive assembly.

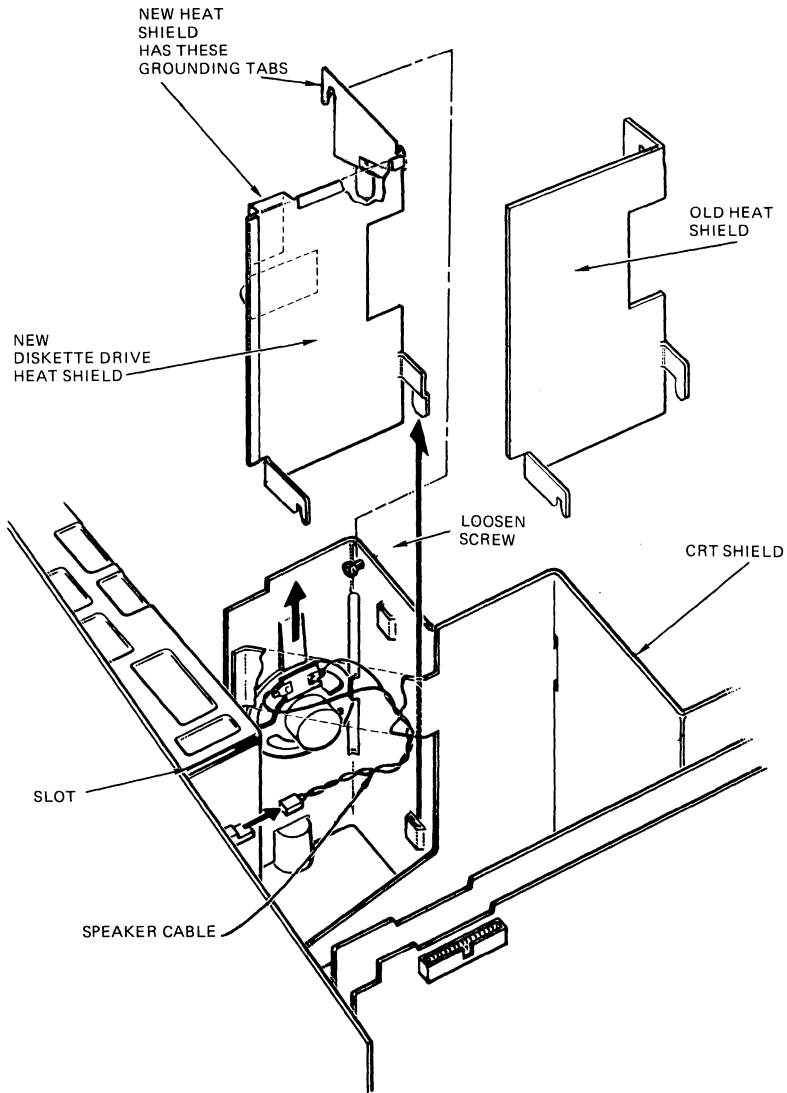

LJ-0922

Figure 5-15 Removing the Speaker



### 5.3.11 Monitor Board Removal

Before you remove the monitor board, make sure you are familiar with the information in *Tech Tip 20, CRT Discharge and Disposal*.

1. Unplug all external cables (Paragraph 5.3.1).
2. Remove the system unit back door (Paragraph 5.3.5) and cover (Paragraph 5.3.6).
3. Loosen, but do not remove, the five screws that hold the webbed shield in place (Figure 5-16).
4. Remove the webbed shield.

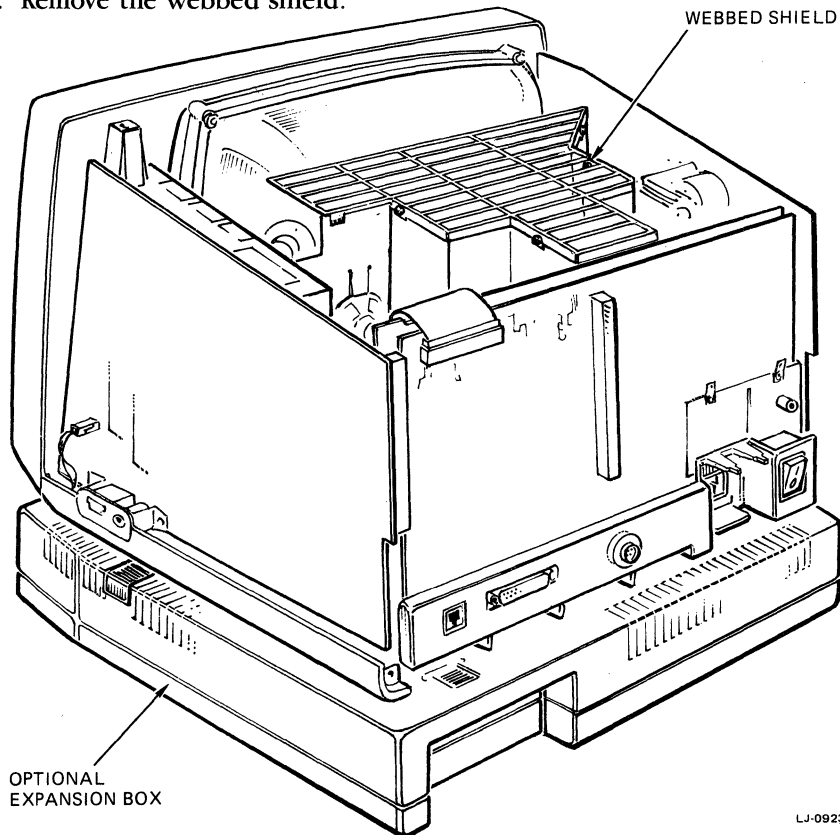

Figure 5-16 Webbed Shield



5. You must always discharge the anode before removing the monitor board or CRT. Carefully discharge the anode as follows.

**WARNING**

The CRT uses very high voltage levels that can harm you. Be careful when discharging the anode.

- a. Clip the anode discharge tool to a chassis ground point near the anode (Figure 5-17).

**NOTE**

Avoid scratching or marring the CRT glass when you insert the tip of the anode discharge tool. The CRT is covered with a protective coating.

- b. Using one hand (keep your free hand away from the CRT) slide the tip of the tool under the rubber boot until the tool touches the anode wire prongs (Figure 5-17). Maintain contact for a full 10 seconds.

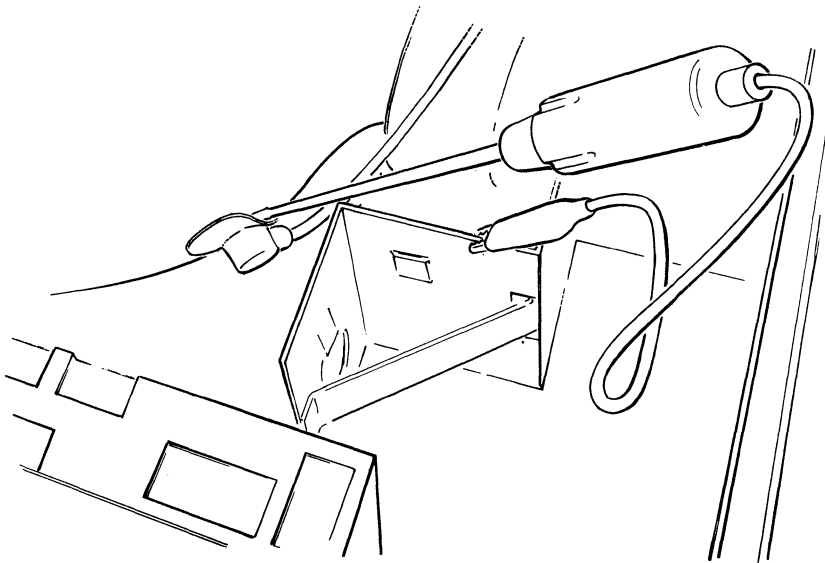

LJ-0924

**Figure 5-17 Discharging the Anode**





6. Carefully remove the anode connector from the CRT as follows. Do not pull the anode connector.

**CAUTION**

Make sure you have discharged the anode.

- a. Fold back one side of the rubber boot while squeezing the prongs together (Figure 5-18).
- b. Lift the anode connector and anode wire away from the CRT (Figure 5-18).

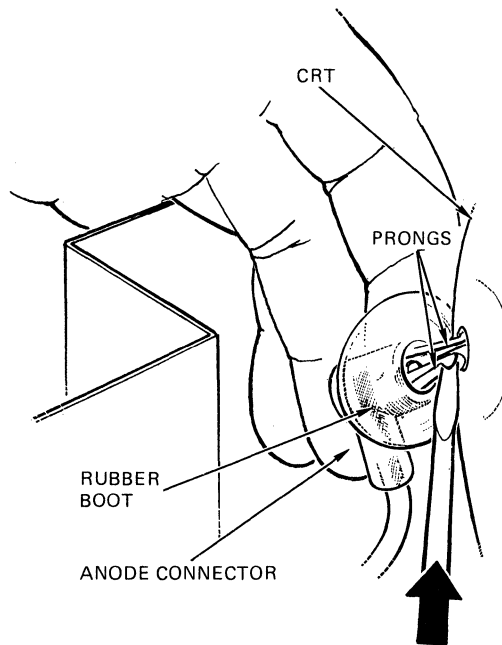

LJ-0925

**Figure 5-18 Removing the Anode Connector**

7. Remove the monitor board as follows.
  - a. Remove the screw, that holds the monitor board to the CRT shield (Figure 5-19).
  - b. Disconnect the monitor board from the I/O-video and power supply boards.

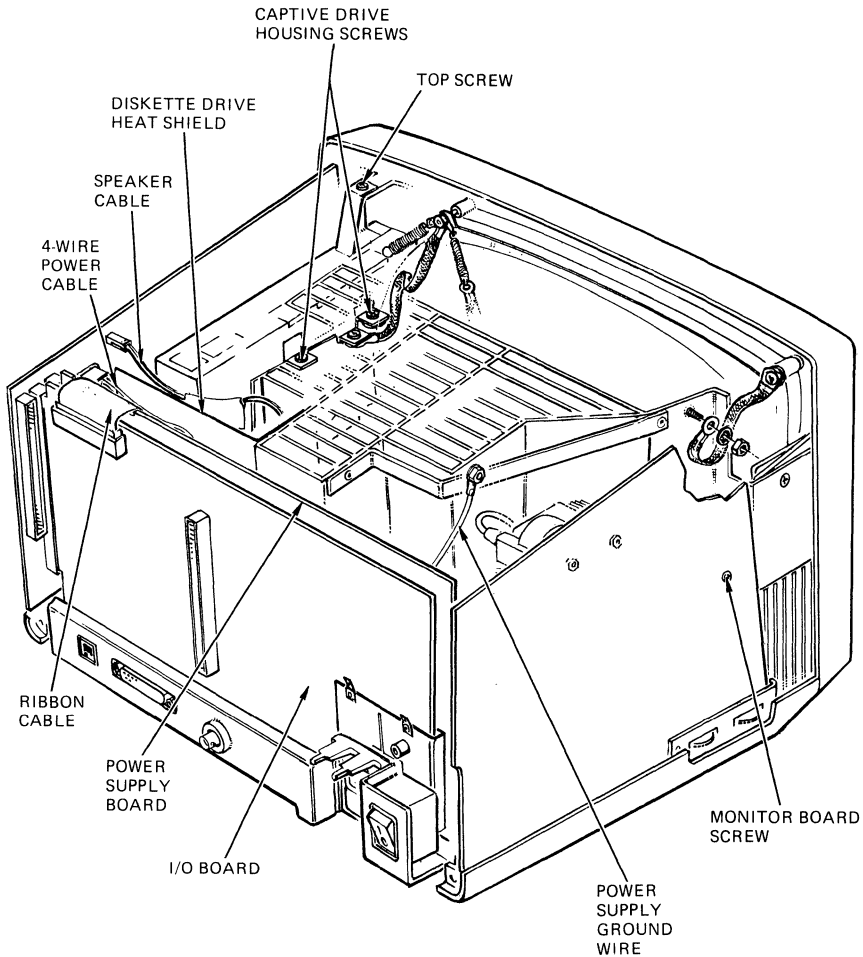

LJ-0926

**Figure 5-19 Monitor Board Screw**



- c. Set the monitor board beside the system unit. You should be able to rotate the board 90 degrees for easier access to the cables.
- d. Unplug the 4-pin cable connector and the 9-pin cable connector from the monitor board (Figure 5-20).
- e. Push the anode wire through the opening in the CRT shield (Figure 5-20).

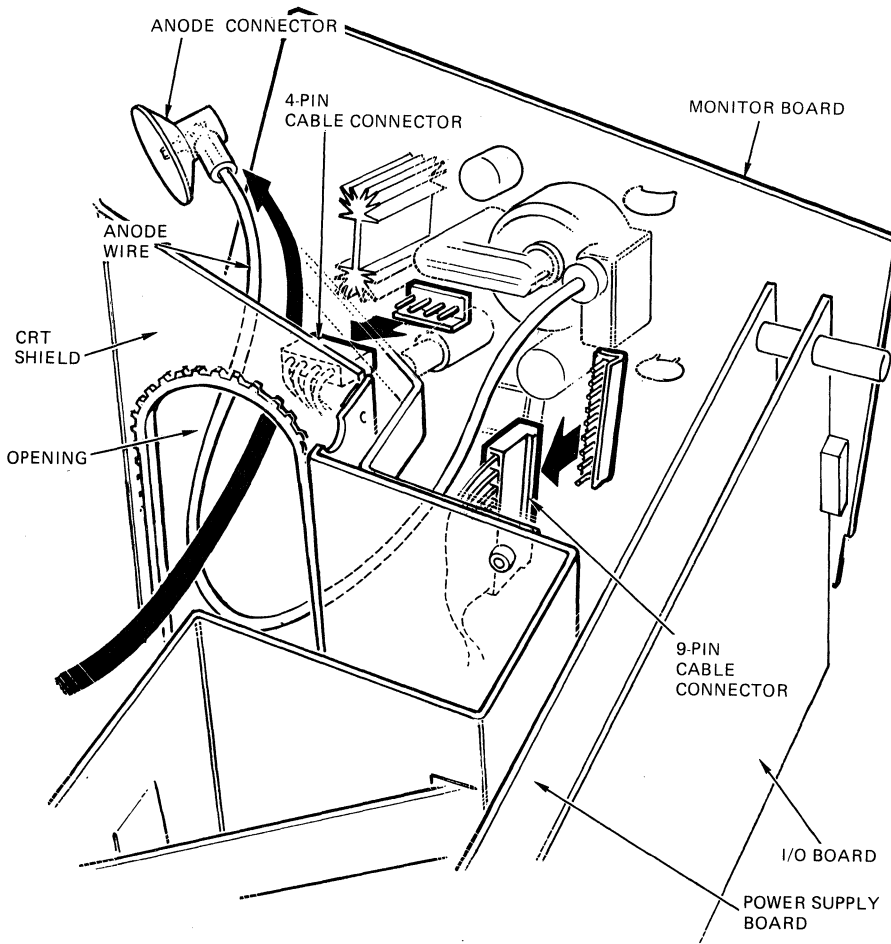

LJ-0927

**Figure 5-20 Unplugging Cables and Pushing Anode Wire Through Shield**



Install the monitor board as follows.

1. Plug the 4-pin and 9-pin connectors into the new monitor board. Make sure the pins are aligned correctly.
2. Connect the monitor board to the I/O-video and power supply boards. Make sure to guide the anode wire through the opening in the CRT shield.
3. Insert the screw that holds the monitor board to the CRT shield.
4. Attach the anode connector as follows.
  - a. Grasp the boot and squeeze the anode connector prongs together.
  - b. Push the prongs into the CRT anode opening until they clip into place.

**WARNING**

Make sure to attach the anode connector firmly and correctly to prevent being injured.

- c. Secure the anode wire to the CRT.
5. Install the webbed shield.
6. Tighten the webbed shield screws.

### 5.3.12 CRT Handling Precautions

Make sure you understand *Tech Tip 20, CRT Discharge and Disposal*, before handling the CRT. Remember the following precautions.

- Wear safety goggles and gloves while working with the CRT.
- Replace the CRT in an area where risks and exposure are limited to DIGITAL service personnel only.
- Do not handle the CRT by its neck. Use two hands to hold the CRT by its sides near the face.
- Keep the CRT away from your body.
- Do not allow the CRT neck to strike anything.
- Do not rest the CRT on its neck.
- Do not let the CRT touch tools, such as screwdrivers and soldering irons.



- Keep the CRT in a closed shipping container or mounted in the device cabinetry.
- When you remove the new CRT from its shipping box, store the faulty CRT in the box with the packing material.
- Seal the box so that only the very tip of the CRT neck is exposed.
- Return the faulty CRT to DIGITAL.

### **5.3.13 CRT Assembly Removal**

The CRT assembly consists of the CRT, yoke, bezel, and braided straps.

1. Unplug all external cables (Paragraph 5.3.1).
2. If an expansion box is present, separate it from the system unit (Paragraph 5.3.2).
3. Follow steps 1 through 7 of the monitor board removal procedure (Paragraph 5.3.11).
4. Place the anode wire over the side of the CRT shield (Figure 5-21). It is not necessary to guide the anode through the CRT shield opening.
5. Remove the 4-pin connector from the monitor board.
6. Push the tilt bar to tilt the screen to its lowest position so the CRT neck is at its highest position.
7. Use the diagonal cutters to cut the tie wrap that holds the 9-wire filament connector to the neck of the CRT.

***WARNING***

Be careful not to cut the wires.

8. Carefully remove the 9-wire filament connector from the neck of the CRT.
9. Remove the white grounding lug cable from the CRT static band by using a needle-nose pliers.
10. Remove the spring and save it to use with the new CRT assembly.
11. If present, remove the braided ground strap from the upper corner of the CRT to the diskette drive tower by removing only the nut at the CRT.
12. Detach the two braided ground straps from the CRT shield by removing the screws.

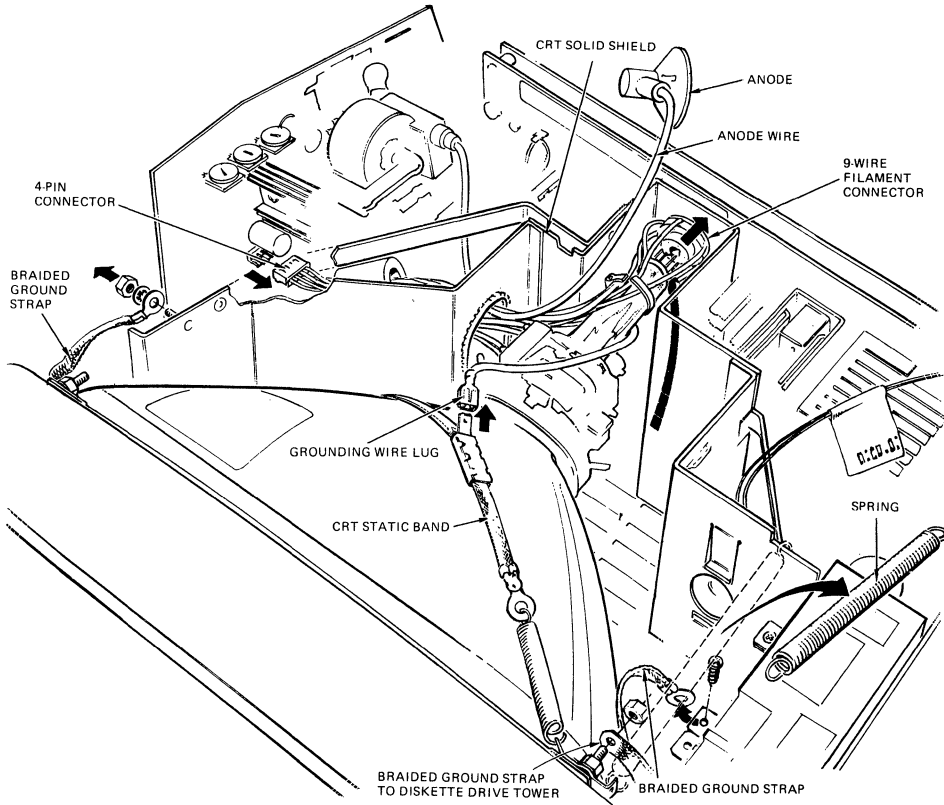

LJ-0928

**Figure 5-21 Removing Connectors, Lug, Spring, and Braided Ground Straps**



13. Disconnect the power LED connector from the CPU board (Figure 5-22).

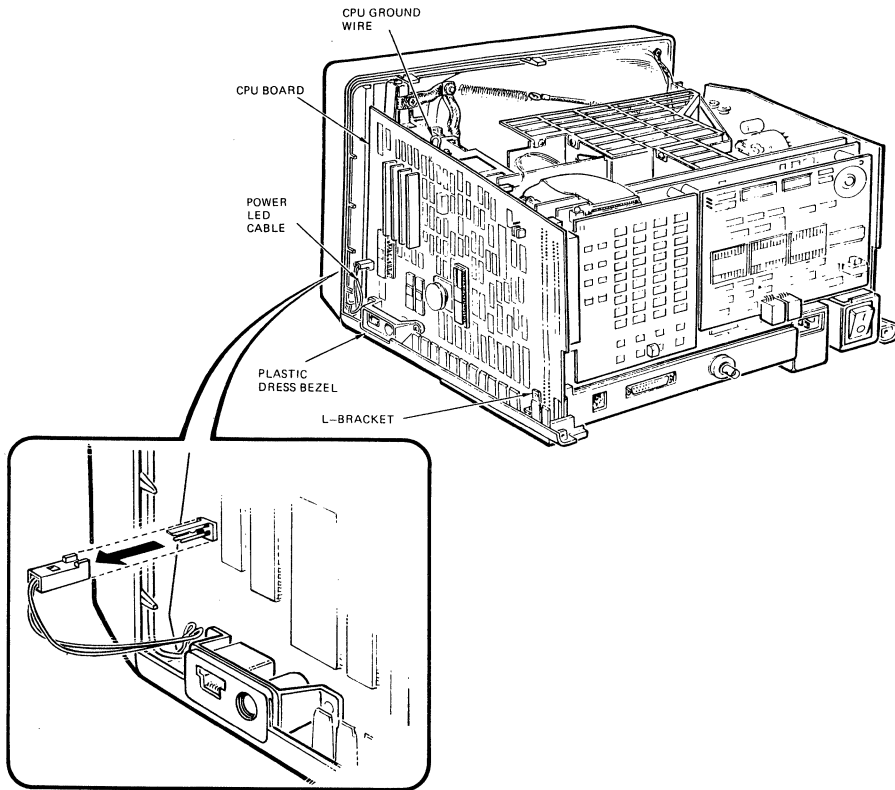

LJ-0929

**Figure 5-22 Disconnecting Power LED Cable**



14. Remove the CRT bezel as follows.
  - a. Use the tilt bar to tilt the screen to its highest position.
  - b. Slide the system unit to the edge of the table.
  - c. Remove the three screws on the underside of the front bezel.
  - d. Remove the left bezel screw (Figure 5-23).
  - e. Use the tilt bar to reposition the screen to its normal level.
  - f. Push the system unit back to the center of the table.
  - g. Remove the diskette drive mounting screw (top) from the diskette drive housing (Figure 5-23).
  - h. Lift the bezel away from the CRT.

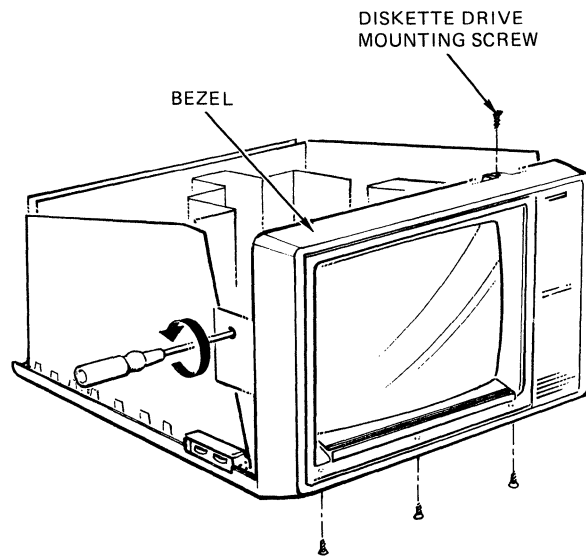

LJ-0930

**Figure 5-23** Removing the Four Bezel Screws and the Top Screw





15. Remove the CRT assembly as follows.
  - a. Push the 4-pin cable through the opening of the CRT shield.
  - b. Grasp each side to lift the CRT assembly (including spring clip) out of the VAXmate pivot cradles (Figure 5-24). Do not lift the CRT out by the neck. The spring clip must clear the tilt channel.

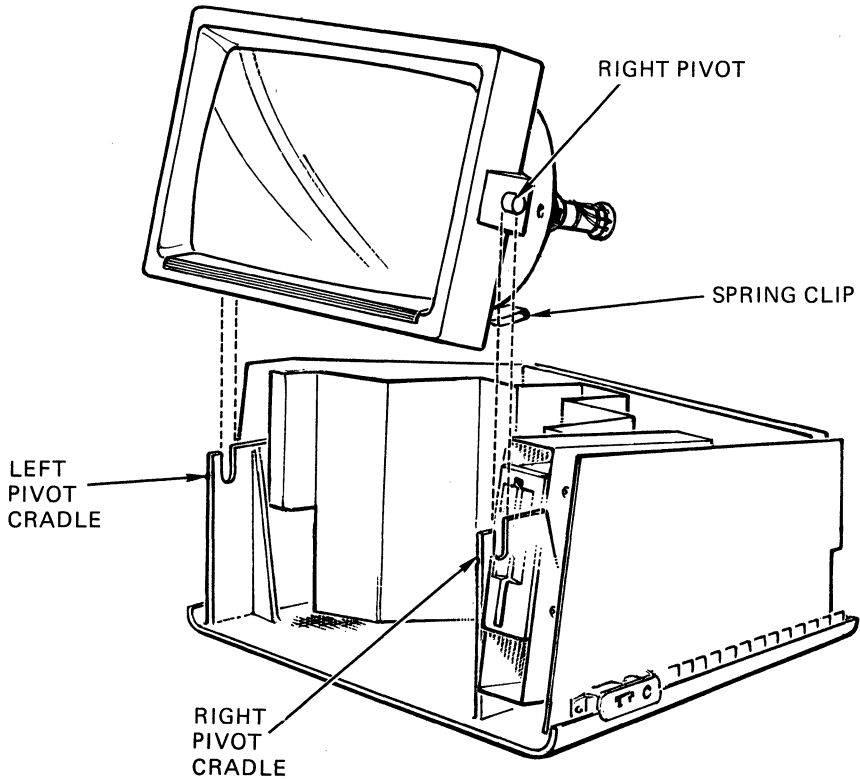

LJ-0932

**Figure 5-24 Removing the CRT Assembly**



### 5.3.14 CRT Assembly Installation

1. Place the CRT left pivot in the left pivot cradle.
2. Position the CRT spring clip in the tilt mechanism's curved channel.

**NOTE**

The spring clip must fit between the top and bottom of the curved channel, or the CRT assembly will not pivot correctly.

3. Insert the right pivot in the right pivot cradle (Figure 5-25). You might have to grasp the top of the diskette drive tower and separate it from the CRT to make more room for the pivot to slide into the cradle.

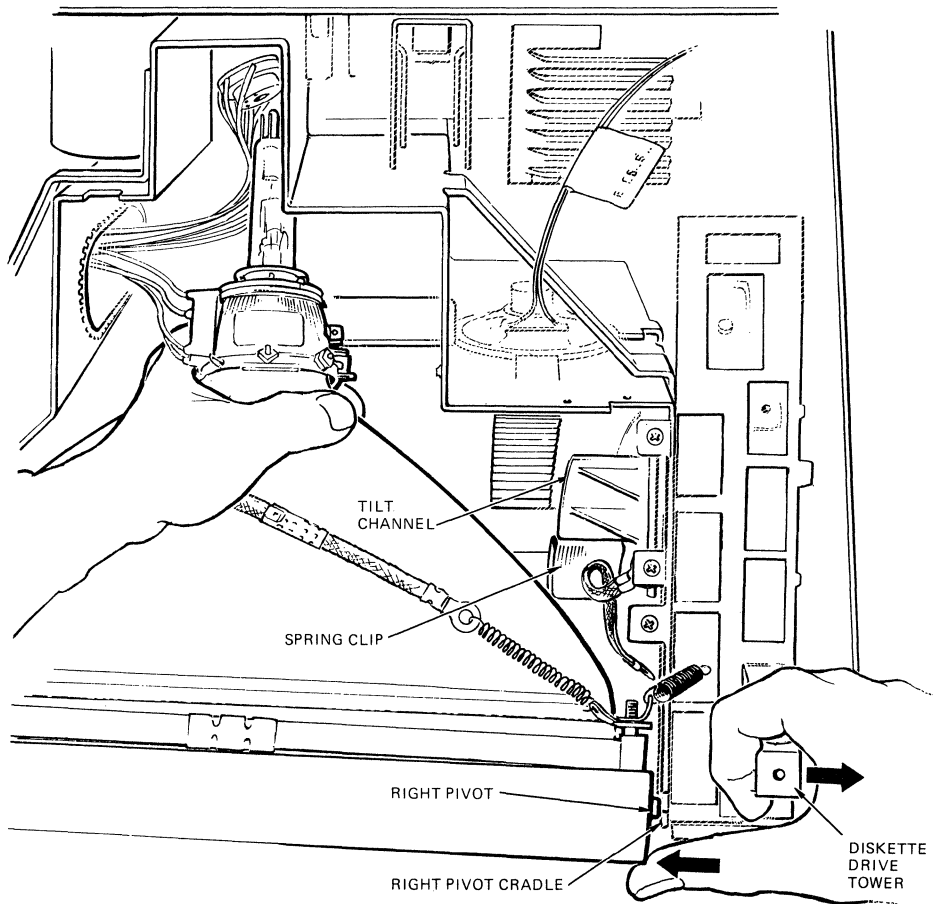

Figure 5-25 CRT Installation



4. Make sure the spring clip and two pivots are installed correctly.

**NOTE**

The spring clip must be halfway into the channel so that the screen is at mid-position, prepared for bezel attachment.

5. Attach the bezel as follows. Make sure the power LED does not catch on the inside.
  - a. Insert the left bezel screw.
  - b. Insert the three screws under the bezel.
  - c. Insert the diskette drive mounting (top) screw.
6. Attach the power LED cable to the CPU board.
7. Tilt the CRT assembly to its lowest position.
8. With the CRT neck at its highest position, connect the 9-wire filament connector to the neck of the CRT.
9. Make sure to secure the wires to the neck of the CRT by fastening a tie-wrap around them.
10. Connect the white ground lug cable.
11. Connect the 4-pin cable to the monitor board.
12. Connect the monitor board to the I/O-video and power supply boards.
13. Insert the screw that holds the monitor board to the CRT.
14. Insert the anode connector in the CRT anode hole.
15. Secure the anode wire to the CRT.
16. Attach the two braided ground straps to the CRT shield.
17. Attach the spring to the spring mount.
18. Attach the webbed shield to the CRT shield.



### 5.3.15 Diskette Drive Removal

1. Remove the system unit from the expansion box, if present.
2. Remove the system unit back door and cover (Paragraphs 5.3.5 and 5.3.6).
3. Remove the diskette drive and housing assembly from the system unit as follows (Figure 5-26).
  - a. Unplug the speaker cable and move the cable out of the way.
  - b. If present, loosen the screw holding the diskette drive heat shield to the CRT shield; then, remove the diskette drive heat shield.
  - c. Remove the diskette drive mounting (top) screw from the diskette drive housing.
  - d. If present, remove the ground strap from the diskette drive tower.

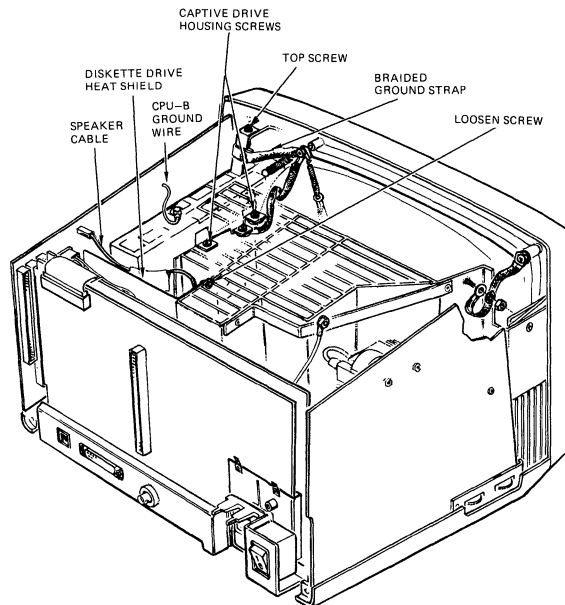

LJ-0926

**Figure 5-26 Removing Cables, Screws, and Heat Shield**



- e. If present, remove the CPU ground wire screw from the diskette drive housing.
- f. Loosen the two captive drive housing screws.
- g. Remove the ribbon cable from the I/O-video board.
- h. Remove the 4-wire power cable from the power supply board.

**NOTE**

Be careful not to damage the speaker plug on the CPU board.

- i. Slide the drive and housing assembly to the rear of the system unit to release the drive housing feet from the slots in the bottom of the system unit. Then, lift out the drive housing (Figure 5-27).

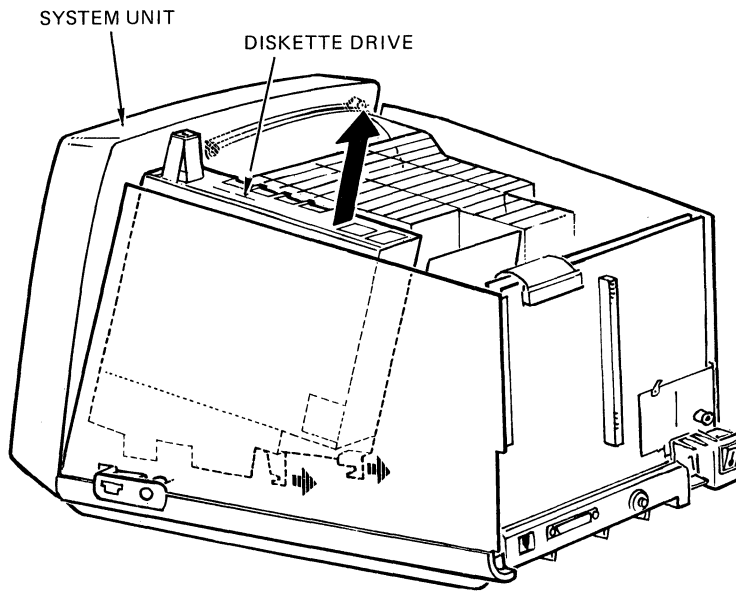

LJ-0934

**Figure 5-27 Sliding Drive and Housing Out of the System Unit**



4. Slide the drive out of its housing as follows (Figure 5-28).
  - a. Disconnect the ribbon cable from the drive.
  - b. Disconnect the power cable from the drive.
  - c. Remove the four mounting screws from the drive housing.
  - d. Slide the diskette drive out of its housing.

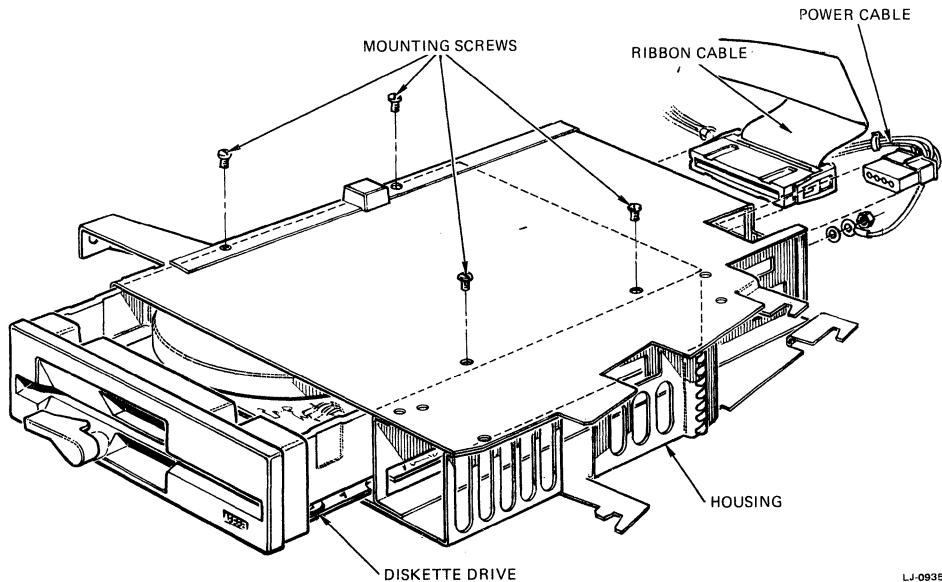

LJ-0935

**Figure 5-28 Sliding the Diskette Drive from Its Housing**



### **5.3.16 Diskette Drive Installation**

1. Remove jumper FG if present (Figure 5-29). This separates the chassis ground from the logic ground.
2. Slide the drive into its housing, making sure to orient the drive correctly.
3. Insert the four mounting screws.
4. Connect the ribbon cable and 4-wire power cable to the drive.
5. Lower the drive housing into the system unit. Guide the feet at the bottom of the housing into the slots in the system unit. Push the housing forward to lock it in position.
6. Tighten the two captive screws.
7. Insert the screw that secures the housing to the front bezel.
8. Plug the power cable into the power supply board.
9. Install the diskette drive heat shield. Make sure the ribbon cable does not get caught in the front of the heat shield.
10. Plug the ribbon cable into the I/O-video board.
11. Plug in the speaker cable.

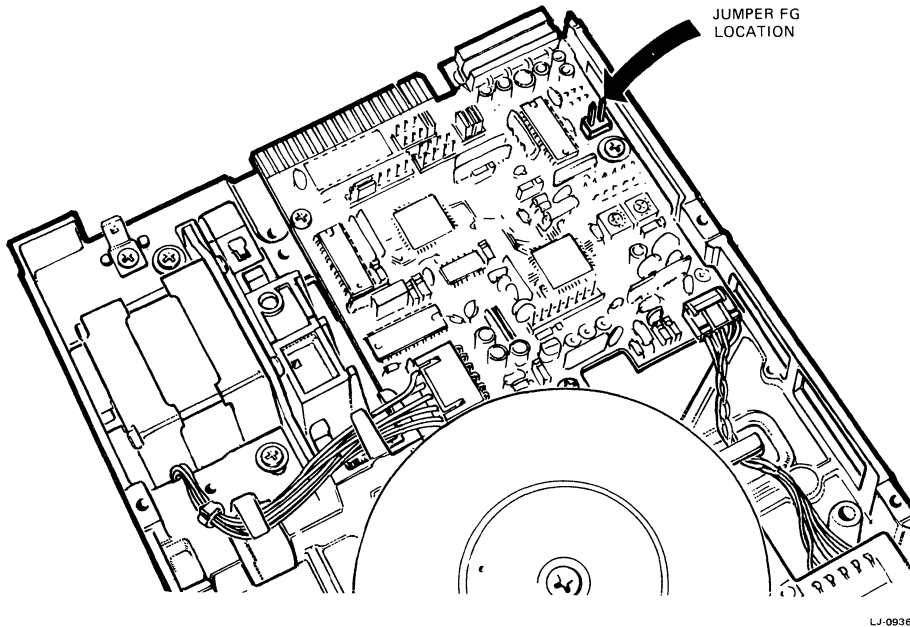

LJ-0936

**Figure 5-29 Jumper FG Location (Diskette Drive)**

### 5.3.17 CPU Board Removal

To remove the CPU board you must lift out the CPU, I/O-video and power supply boards together, as one assembly, and then separate the CPU board from this assembly. Remove the CPU board as follows.

1. If an expansion box is attached, separate it from the system unit.
2. Remove the system unit back door (Paragraph 5.3.5) and cover (Paragraph 5.3.6).
3. Unplug the speaker cable from the CPU board.
4. Unplug the power LED cable from the CPU board (Figure 5-30).
5. Remove the plastic dress bezel from the CPU board by loosening its two captive screws (Figure 5-22).



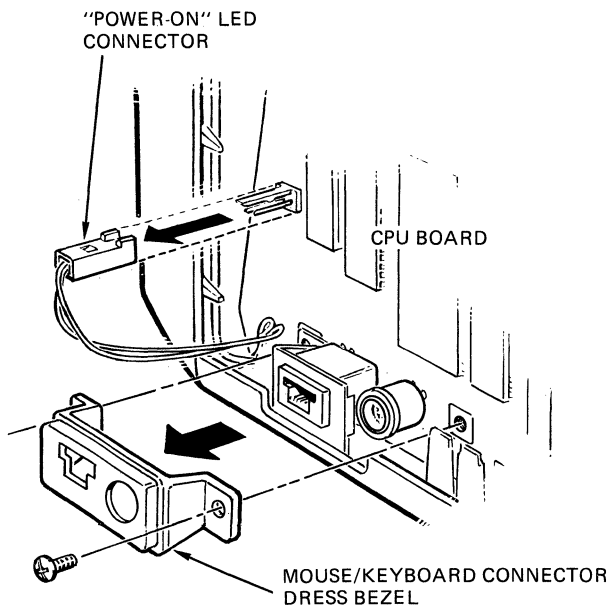

LJ-1472

**Figure 5-30 Removing LED Cable and Plastic Dress Bezel**

6. If present, remove the CPU ground wire screw from the diskette drive housing (Figure 5-26).
7. Loosen the captive screw at the L-bracket (Figure 5-9).
8. Remove the ribbon cable from the I/O-video board.
9. Remove the 4-wire power cable from the power supply board.
10. Remove the screw that holds the monitor board to the CRT shield.
11. Disconnect the power supply ground wire (Figure 5-31).
12. Separate the monitor board from the I/O-video and power supply boards.

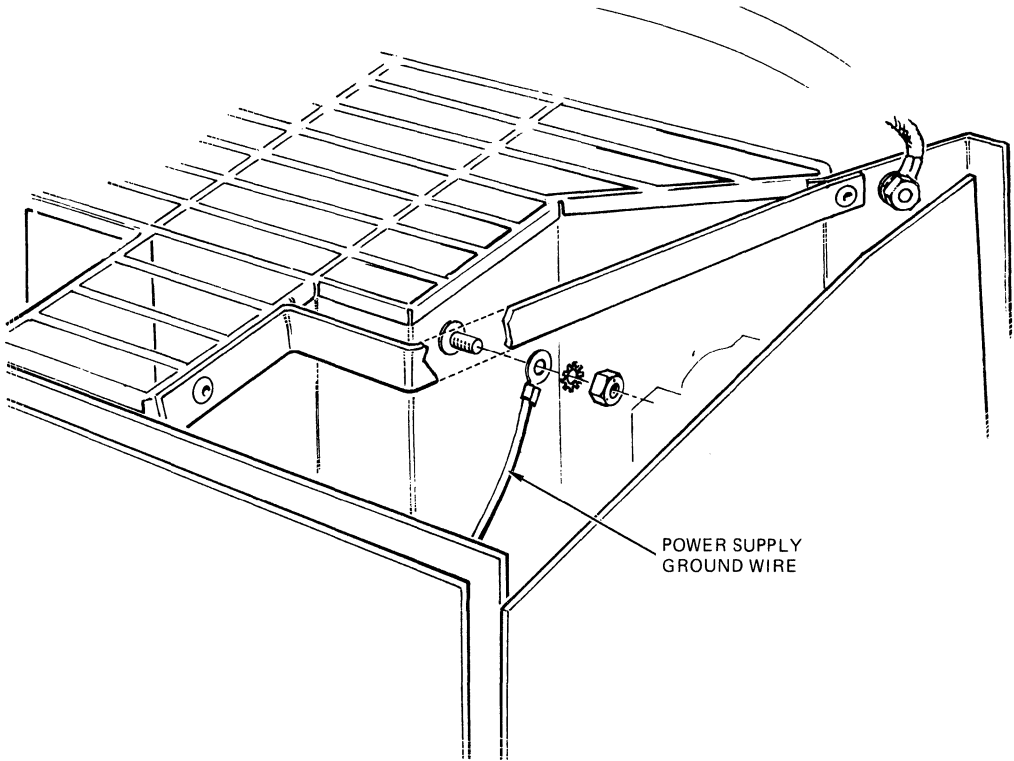

LJ-0937

**Figure 5-31 Power Supply Ground Wire**

**NOTE**

You do not have to unplug any cables from the CRT or monitor board.

Set the monitor board outside the system. You can rotate the monitor board 90 degrees to have more working space.



13. Lift the power supply, I/O-video and CPU boards out together (Figure 5-32).
14. Separate the CPU board from the power supply and I/O-video boards.

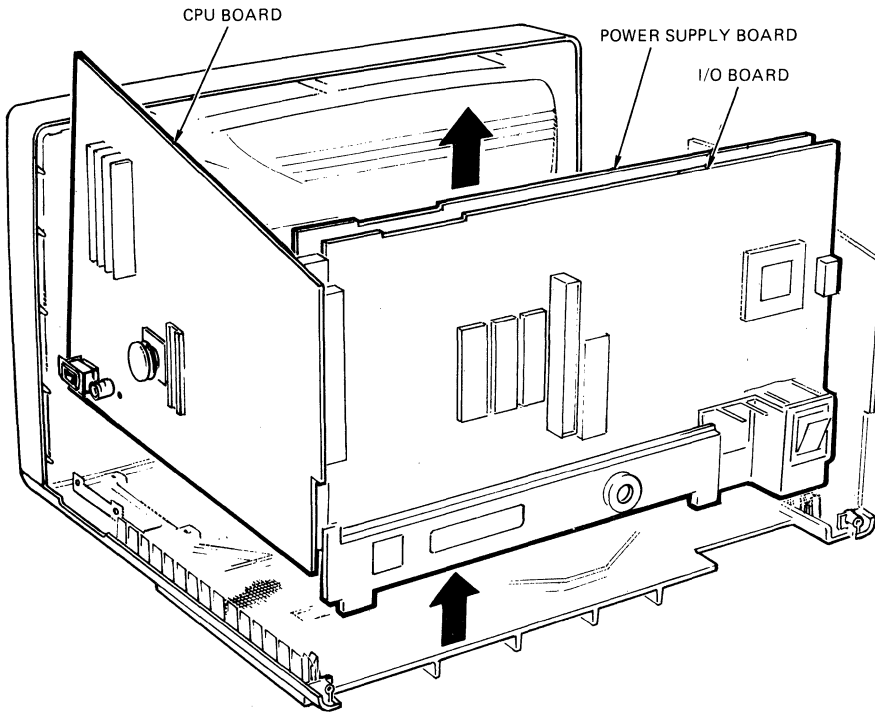

LJ-0938

**Figure 5-32 Lifting Out Power Supply, I/O-video, and CPU Boards**



15. Remove the following components, if present, from the CPU board by using a chip removal tool (Figure 5-33). Save the components for the new CPU board.

- Math coprocessor chip (80287)
- Ethernet address chip

**CAUTION**

You must install the old Ethernet address chip on the new CPU board. This chip contains the user's location as registered with the network. Also, install the new Ethernet address chip to the faulty CPU board, then return the faulty CPU board to the branch office for repair.

- Note the settings for jumpers W1 through W3.

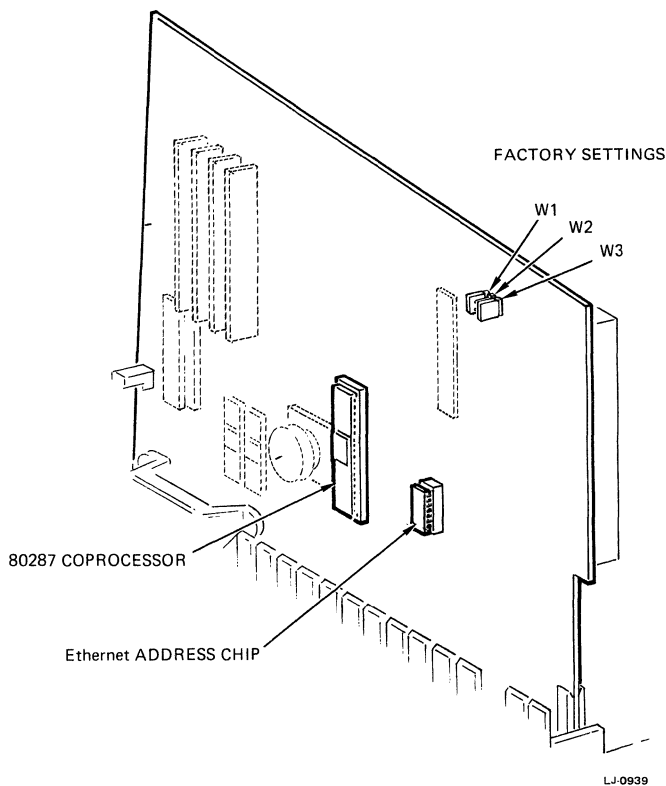

**Figure 5-33 CPU Board Components and Jumpers**



### 5.3.18 CPU Board Installation

In order for the VAXmate workstation to remain compliant with FCC Class A regulations on computer emissions, **do not** install the new CPU board (p/n 17-17187) unless the mechanical parts listed in the PC500-UA kit are already installed.

The PC500-UA enhanced CPU and grounding kit contains one of each of the following.

- Braided ground strap with 10-32 X 1/2" screw and nut
- New diskette drive heat shield
- 6-32 X 3/8" screw
- 8-32 kep-nut
- CPU board (part number 54-17187)
- Instructions

The old board and the new board basically function the same, but the new board solves the EGA/network conflict. The new diagnostic ROM tests this function. Do not exchange ROMs between old boards and new boards, or errors will result and the system might halt. The new board also has a different part number.

Old numbers:        Etch 50-16846 Revision D1 (or earlier)  
                          p/n 54-16847

New numbers:        Etch 50-17186 Revision B1 (or later)  
                          p/n 54-17187

Use the following procedure to replace the CPU board.

1. If the 80287 coprocessor chip was present, install it on the new CPU board.
2. Install the old Ethernet address chip on the new CPU board. Install the new Ethernet address chip on the faulty CPU board.
3. Set the CPU board jumpers (Figure 5-33). If the VAXmate workstation does not have a diskette drive, make sure to remove jumper W3 (Paragraph 2.3.2).
4. Connect the CPU board to the power supply and I/O-video boards. Check to make sure the power pins on the back of the CPU board are installed correctly.
5. Install the entire assembly in the system unit.



6. Connect the CPU ground wire to the top of the diskette drive.
7. Connect the power supply ground wire.
8. Install the monitor board. Make sure to insert the screw that holds the monitor board to the CRT shield.
9. Connect the ribbon cable to the I/O-video board.
10. Connect the 4-wire power cable to the power supply board.
11. Tighten the captive hold-down screw at the L-bracket at the bottom right of the CPU board.
12. Install the plastic dress bezel by tightening its two captive screws.
13. Plug the speaker cable and the power LED cable into the CPU.



### 5.3.19 Power LED Removal

1. Remove the system unit back door (Paragraph 5.3.5) and cover (Paragraph 5.3.6).
2. Disconnect the LED cable from the CPU board (Figure 5-22).
3. Use a screwdriver to push the LED assembly out from the CRT bezel while you gently pull the LED wire from behind (Figure 5-34).

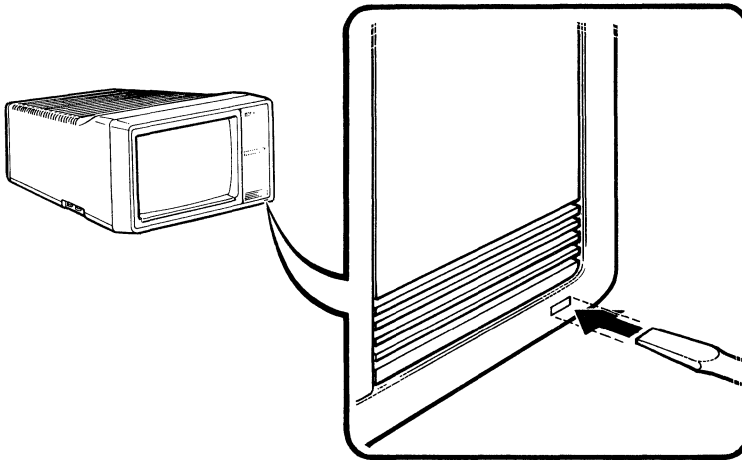

LJ-0940

**Figure 5-34** Removing the Power On LED Assembly



### 5.3.20 Power LED Installation

1. Slide the new LED assembly under the diskette drive door spring and into the LED opening (Figure 5-35).
2. Use the screwdriver to push the LED in firmly. Do not damage the wires to the LED.
3. Connect the LED cable to the CPU board.

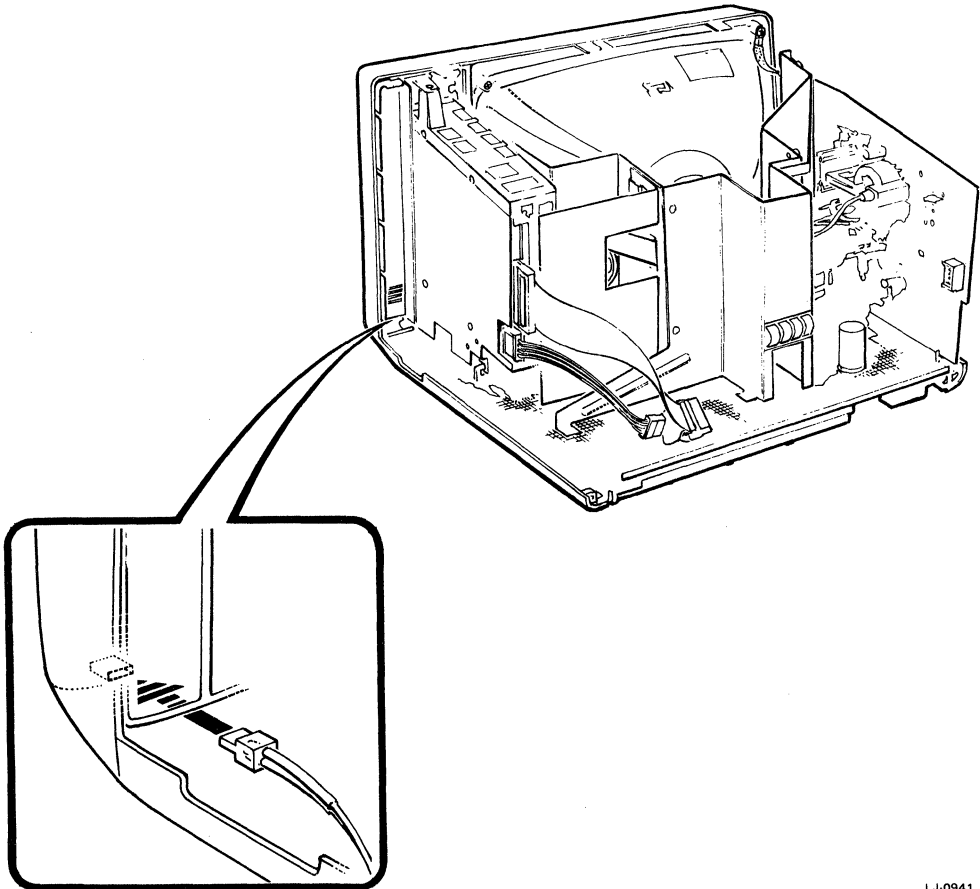

LJ-0941

**Figure 5-35** Replacing the Power LED Assembly





### 5.3.21 I/O-Video Board Removal

1. Do steps 1 through 14 of the CPU board removal procedure (Paragraph 5.3.17).
2. Remove the five mounting screws that secure the power supply board to the I/O-video board (Figure 5-36).

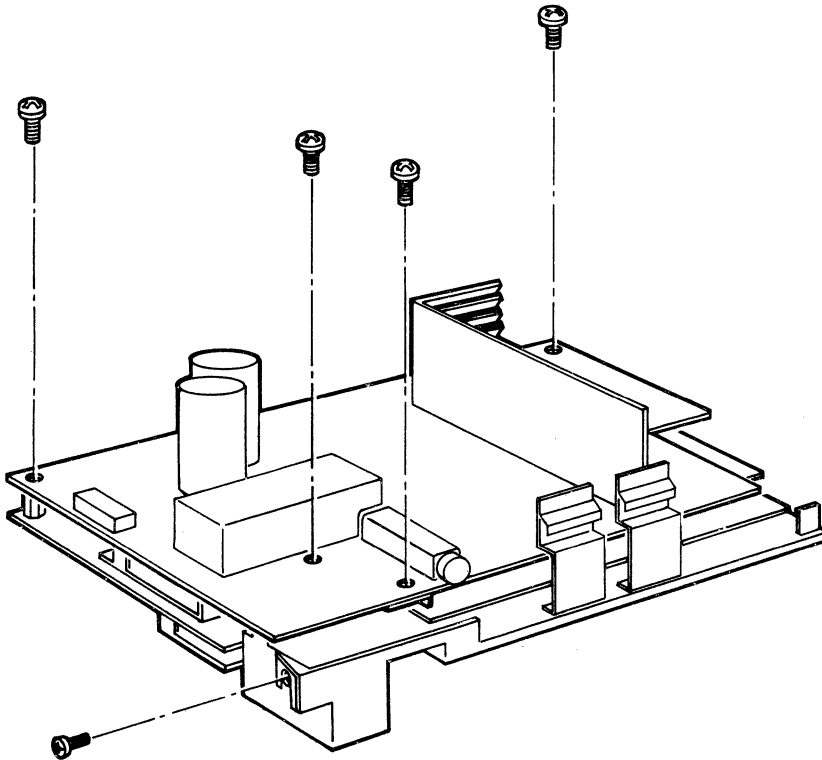

LJ-0942

Figure 5-36 Mounting Screws



3. Remove the I/O-video board plastic bezel by removing the two screws that hold the bezel in place (Figure 5-37). Save the bezel to install on the new I/O-video board.

**NOTE**

The I/O bezel contains the system unit serial number. You must use this bezel on the new I/O-video board.

4. Separate the I/O-video board from the power supply board.

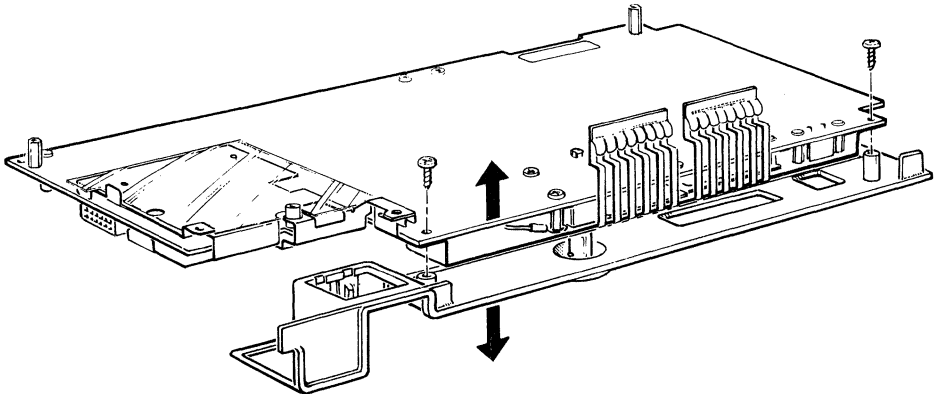

LJ-0943

**Figure 5-37 Removing the I/O-Video Board Bezel**



5. Remove the metal I/O-video board shield as follows. You must also install the shield on the new I/O-video board.
  - a. Remove the two connectors from the shield.

**CAUTION**  
Be careful not to pull the wires off the board.

  - b. Remove the screw (Figure 5-38).

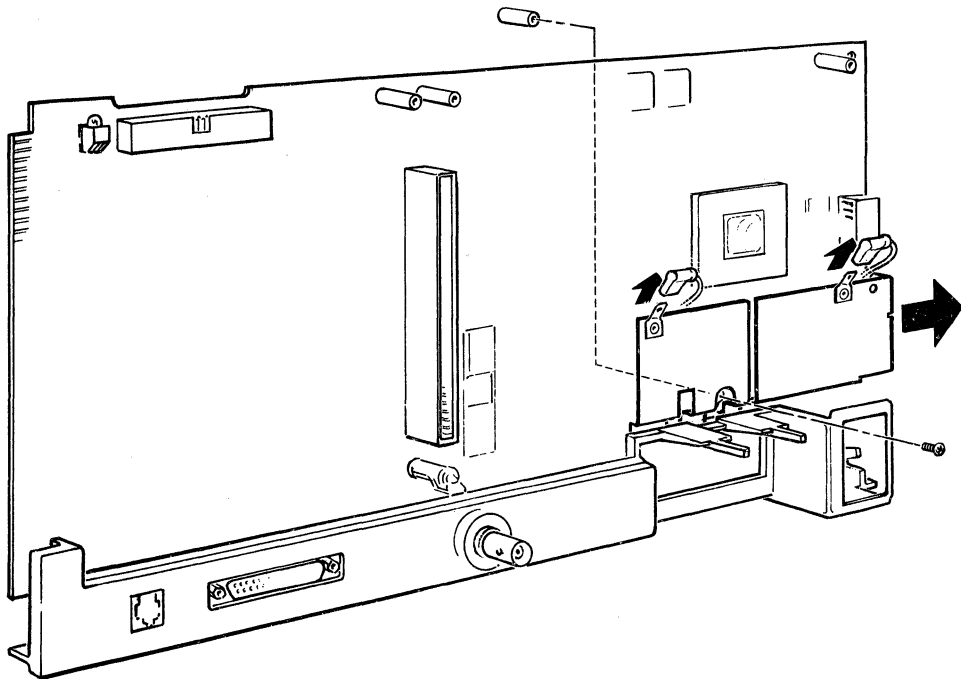

LJ-0944

**Figure 5-38 Removing the I/O-Video Board Shield**



### 5.3.22 I/O-Video Board Installation

1. Install the old plastic bezel on the new I/O-video board.
2. Install the old metal I/O-video board shield on the new I/O-video board.
3. Attach the I/O-video board to the power supply board by inserting the five mounting screws.
4. Attach the CPU board to the I/O-video and power supply board assembly.
5. Place the 3-board assembly into the system unit.
6. Attach the monitor board. You might have to slightly lift up the 3-board assembly.
7. Connect the following cables.
  - a. 4-wire power cable to the power supply board
  - b. Ribbon cable to the I/O-video board
  - c. CPU ground wire to the top of diskette drive assembly
  - d. Speaker cable to the CPU board
  - e. Power LED cable to the CPU board
  - f. Power supply ground wire to the CRT shield
8. Insert the screw that secures the monitor board to the CRT shield.
9. Tighten the captive hold-down screw at the L-bracket at the bottom right of the CPU board.
10. Install the plastic dress bezel to the CPU board by tightening its two captive screws.
11. Reinstall the cover and the back door on to the system unit.



### **5.3.23 Power Supply Board Replacement**

1. Do steps 1 through 13 of the CPU board removal procedure (Paragraph 5.3.17).
2. Remove the five mounting screws from the power supply board (Figure 5-36).
3. Separate the power supply board from the I/O-video board.
4. Attach the new power supply board to the I/O-video board by reversing the removal procedures.

### **5.3.24 Expansion Box Cover Removal**

1. Remove all external cables (Paragraph 5.3.1).
2. Separate the expansion box from the system unit (Paragraph 5.3.2).
3. Release the cover lock and lift up the front edge of the cover. Then, lift the cover straight up (Figure 5-39).

To replace the cover, make sure no expansion box wires or cables are hanging outside the expansion box. Then, lower the back corners of the cover into the back corners of the expansion box base. Make sure the corners are seated correctly, then lower the cover in place.

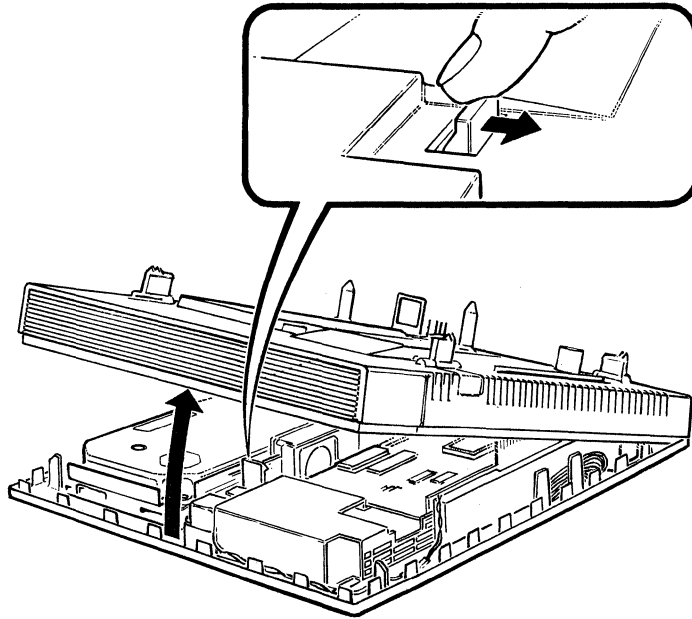

LJ-0819

**Figure 5-39 Removing the Expansion Box Cover**



### **5.3.25 Hard Disk Drive Removal**

The hard disk drive is fragile – handle it carefully. Always try replacing the hard disk drive read/write board before you replace the entire hard disk drive. If the replacement drive has a skid plate attached to it, remove the skid plate (screws and spacers) and attach it to the defective drive.

***NOTE***

If the expansion box contains a fan assembly refer to Paragraph 5.3.26 for removal procedures.

1. Use the Service Diagnostics to park the drive head (Individual Test number 18, Park All Drives).
2. Remove all external cables (Paragraph 5.3.1).
3. Separate the system unit from the expansion box (Paragraph 5.3.2).
4. Remove the expansion box cover (Paragraph 5.3.24).
5. Disconnect the two flat gray cables from the hard disk drive controller board (Figure 5-40).
6. Remove the 4-wire power connector from the hard disk drive.
7. Remove the four screws from the drive base plate (Figure 5-40) and continue with Paragraph 5.3.27.

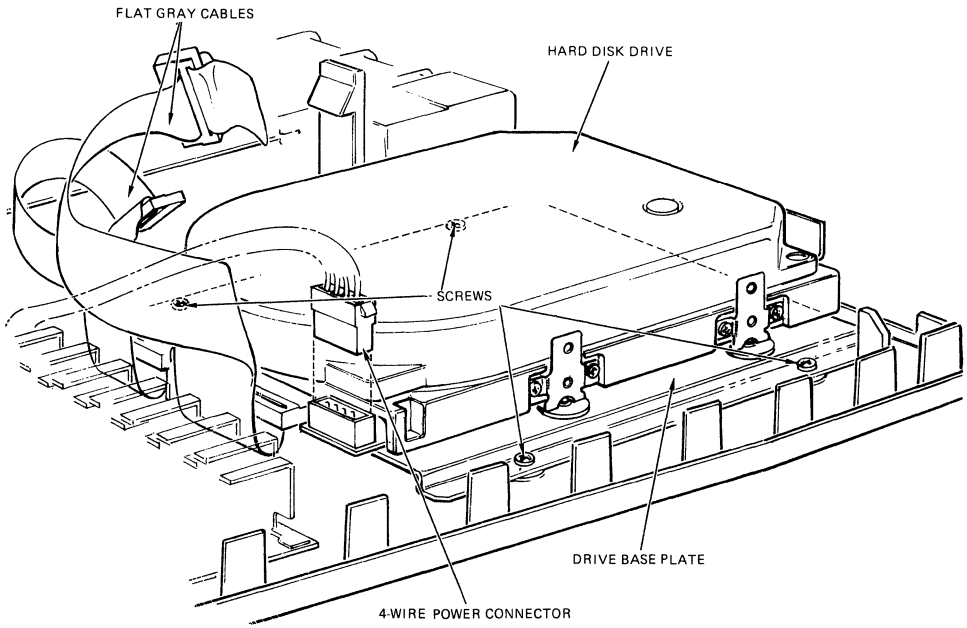

LJ-1032

**Figure 5-40 Hard Disk Drive Cables and Screws**





### 5.3.26 Hard Disk Drive Removal with Fan Present

The hard disk drive is fragile – handle it carefully.

1. Use the Service Diagnostics to park the drive head (Individual Test number 18, Park All Drives).
2. Remove all external cables (Paragraph 5.3.1).
3. Separate the system unit from the expansion box (Paragraph 5.3.2).
4. Remove the expansion box cover (Paragraph 5.3.24).
5. Disconnect the two signal cables from the hard disk drive controller board (Figure 5-41)

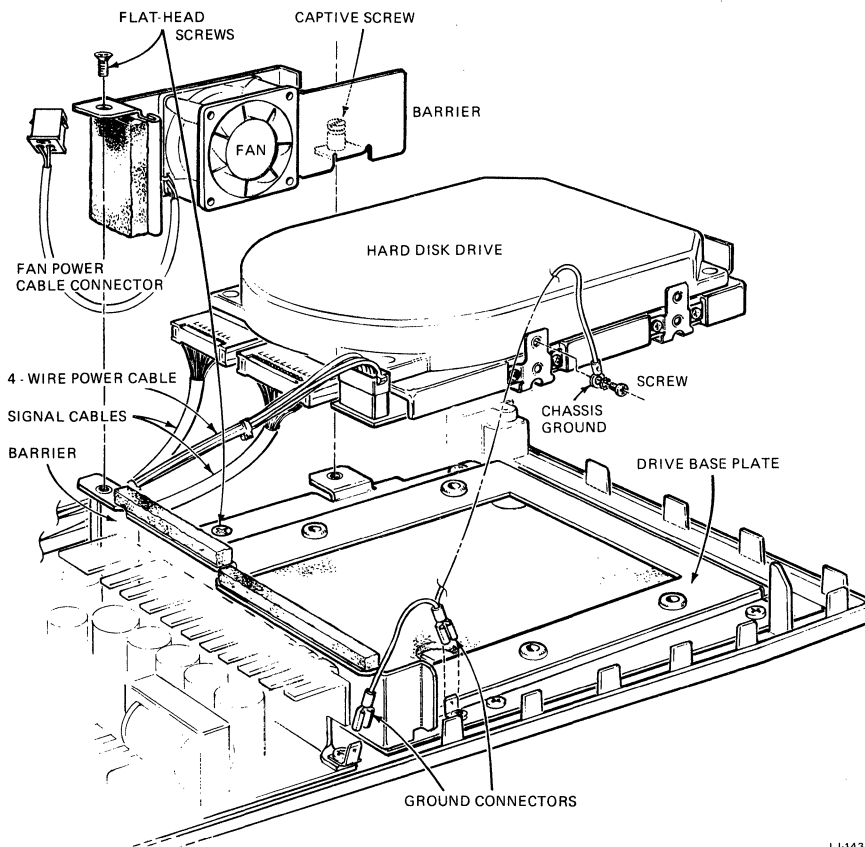

LJ-1431

Figure 5-41 Hard Disk Drive Removal with Fan Present



6. Disconnect the 4-wire power connector from the hard disk drive.
7. Disconnect the ground wire from the hard disk drive and from the base plate.
8. Disconnect the 2-wire fan power connector from the power regulator fan connector.
9. Remove the fan assembly by removing one flat-head screw and loosening a captive screw and lifting the fan assembly straight up. This procedure exposes a flat head screw that secures the drive base plate to the expansion box.
10. Remove the flat head screw and three other screws from the drive base plate.
11. Remove the barrier between the hard disk drive and the power regulator.
12. Remove the two signal cable from the hard disk drive.

***CAUTION***

The hard disk drive is fragile – handle it carefully to avoid media damage.

13. Remove the hard disk drive assembly and place it on a work surface with the drive base plate facing up.



### 5.3.27 Hard Disk Drive Base Plate Removal

Remove the drive base plate as follows.

1. Carefully place the drive upside down on a grounded work surface.
2. Disconnect the two flat or round gray cables from the hard disk drive.
3. Remove the four shock mounting screws (Figure 5-42). Set the base plate aside to install on the new drive.

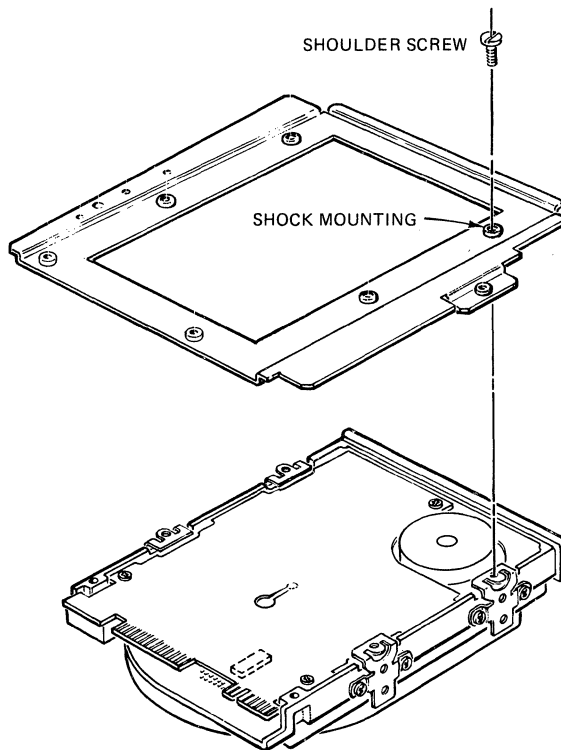

LJ-1432

**Figure 5-42 Removing Base Plate**



### 5.3.28 Read/Write Board Removal from the Hard Disk

Remove the read/write board if the customer has data on the hard disk that cannot be retrieved. Install the read/write board on the new hard disk drive.

1. Do steps 1 through 7 of the hard disk drive removal procedure (Paragraph 5.3.25) or steps 1 through 12 of the hard disk drive removal with fan present (Paragraph 5.3.26).
2. Remove the hard disk drive base plate (Paragraph 5.3.27).
3. Remove the three screws and insulating washer from the read/write board (Figure 5-43).

#### **CAUTION**

Make sure you remove the read/write board washers. A washer accidentally dropped in the disk drive can damage the drive.

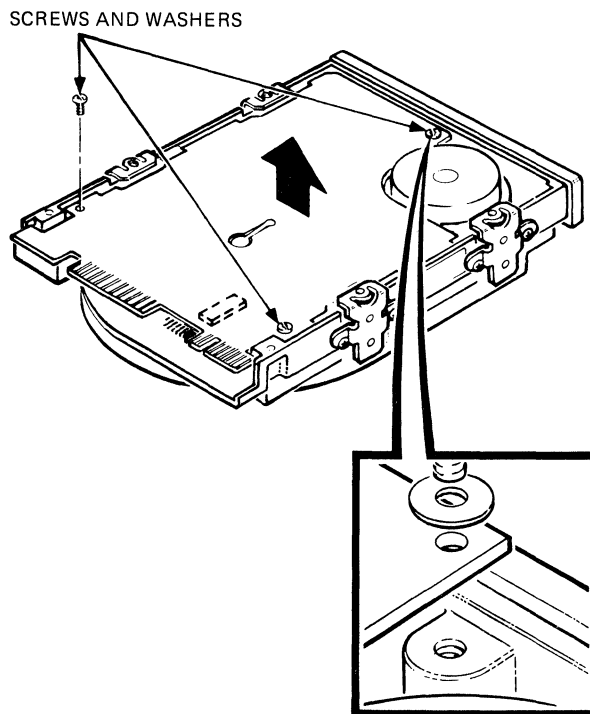

LJ-0694A

**Figure 5-43** Read/Write Board Screws and Washers



4. Remove connectors 1 and 2 from the bottom of the read/write board as follows.

**CAUTION**

The connectors are attached to lead wires. Pulling the read/write board straight up can damage the wires.

- a. Firmly hold the disk drive with one hand.
  - b. Gently lift the side of the read/write board about 1/2 inch.
  - c. Use your fingers to remove connector 1 and then connector 2. Do not use a metal tool.
5. Lift the board as shown in Figure 5-44 and then remove connector 3 (Figure 5-45).

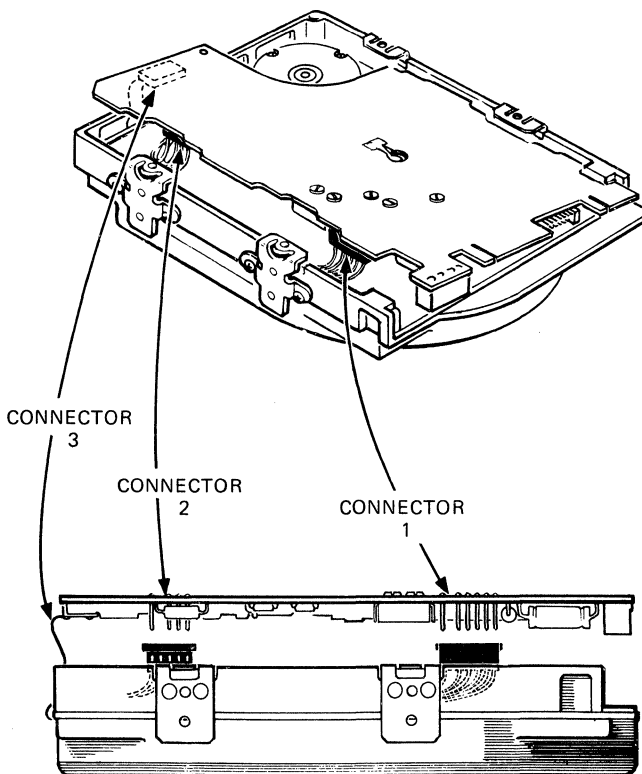

LJ-0695A

**Figure 5-44 Removing Connectors 1 and 2**

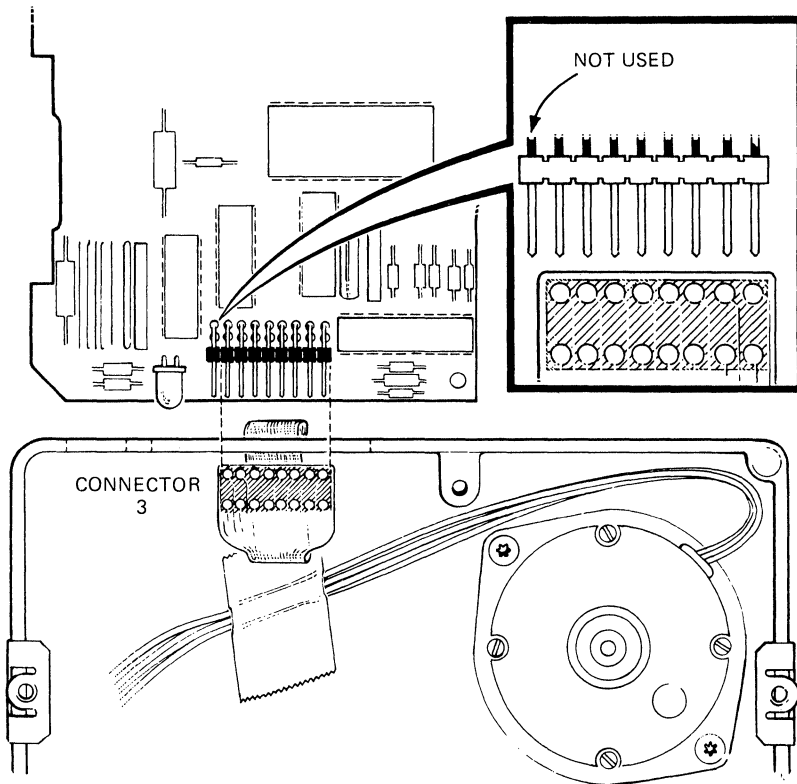

LJ-0696 A

**Figure 5-45 Removing Connector 3**

### 5.3.29 Read/Write Board Installation

1. Attach connector 3 to the read/write board.

**NOTE**

Make sure the pair of pins next to the LED are exposed (Figure 5-45).

2. Hold the hard disk drive firmly, lower the read/write board and carefully install connector 2 and then connector 1.
3. Install the read/write board.

**CAUTION**

Remember to install the read/write board insulating washers.



*FRU Replacement*

4. Make sure the jumper clip is set to drive select 1 (Figure 5-46).
5. Install the hard disk drive (Paragraph 5.3.31).

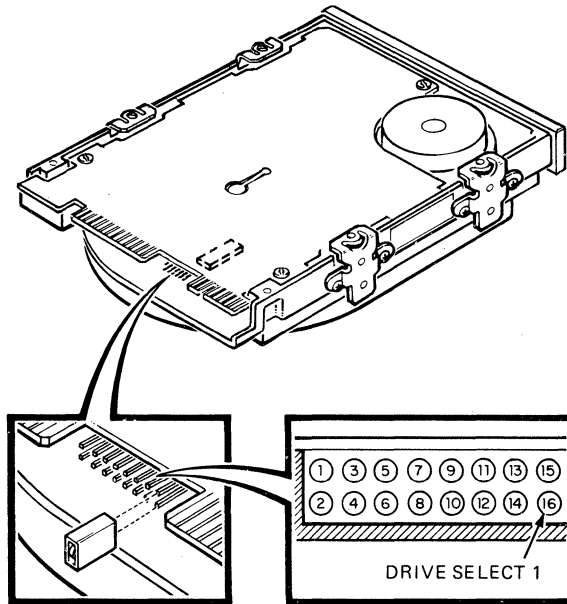

LJ-0697A

**Figure 5-46 Jumper Setting for Drive Select**



### 5.3.30 Removing Skid Plate from New Hard Disk

Before you install a replacement hard disk drive, you must remove the skid plate from the new drive. Remove the hard disk drive skid plate as follows.

#### **CAUTION**

The hard disk drive is fragile – handle it carefully to avoid media damage.

1. Remove the four screws and four standoffs that secure the skid plate to the hard disk drive that is being installed (Figure 5-47).
2. Attach the skid plate to the defective hard disk drive for shipment to the repair facility.

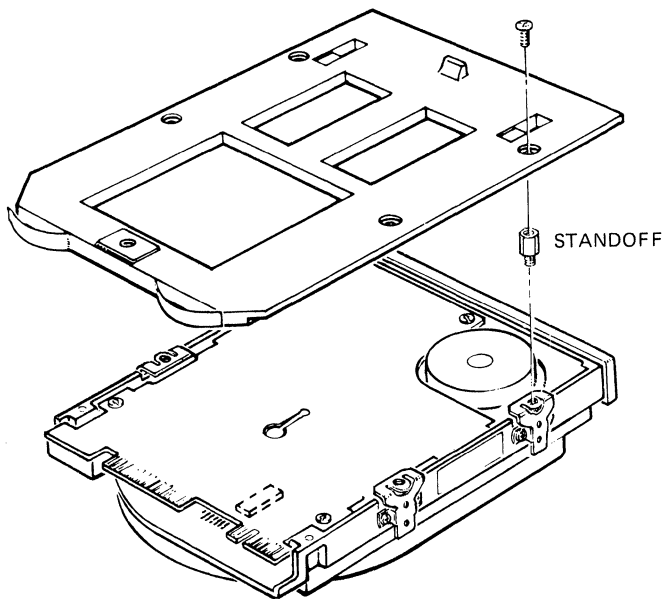

LJ-1473

**Figure 5-47 Removing Skid Plate**





### 5.3.31 Hard Disk Drive Installation

The hard disk drive is fragile – handle it carefully. If the replacement drive has a skid plate attached to it, you must remove this skid plate (screws and spacers) and attach it to the effective drive (Paragraph 5.3.30).

1. Secure the base plate removed from the original drive to the drive being installed with four shock mounting screws. Carefully turn the screws clockwise just until they touch the drive chassis (Figure 5-48).
2. Make sure the jumper clip on the replacement drive is set to drive select 1 (Figure 5-46).
3. Connect the two flat or round gray signal cables to the hard disk drive.

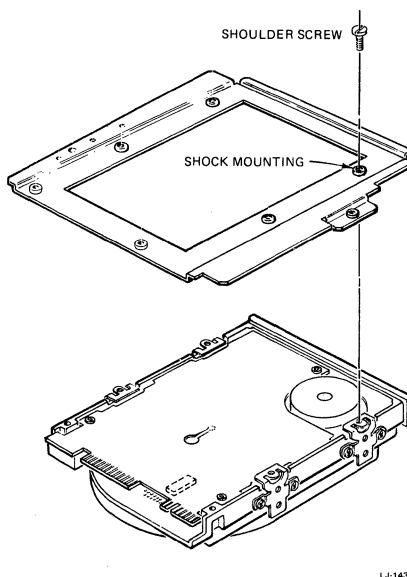
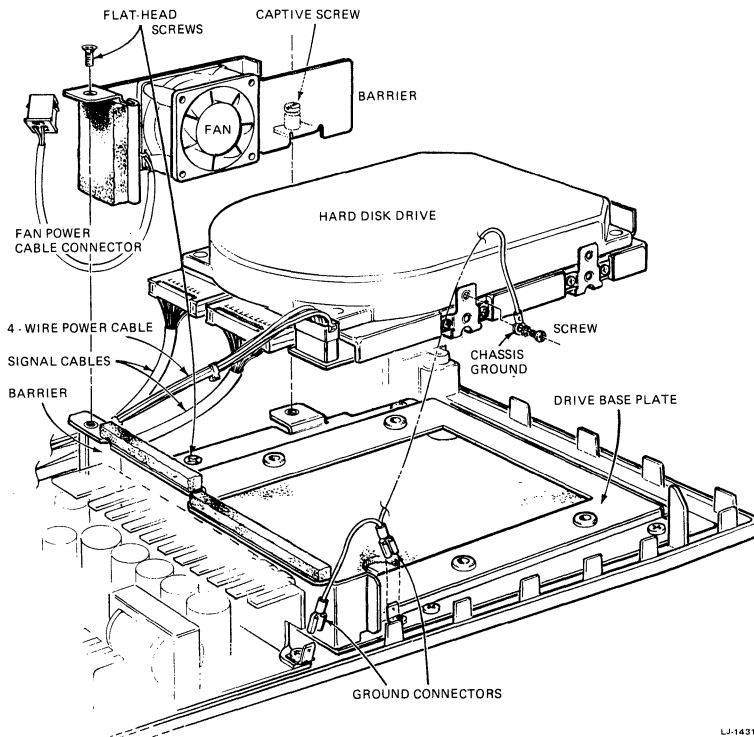

**Figure 5-48 Replacing Base Plate**

4. If a fan is present, secure the barrier (part number 74-35037) to the base plate with the two captive screws (Figure 5-49)
5. Secure the hard disk drive assembly to the expansion box using three 6-32 X 0.125 pan screws and one 6-32 X 0.125 flat head screw.



6. Connect the power cable to the drive.
7. Route the two signal cables and the power cable along the barrier (if present), and connect the signal cables to the hard disk drive controller board and the power cable to the power regulator (Figure 5-49).



LJ-1431

**Figure 5-49 Hard Disk Drive Installation**

8. If present, connect the ground wires from the power regulator ground stud to the hard disk drive ground stud and to the chassis ground.
9. If present, install the fan assembly and connect the 2-wire fan power connector to the power regulator fan connector.
10. Install the expansion box cover (reverse Paragraph 5.3.24). Make sure no cables, other than option board cables, are hanging outside the expansion box, otherwise the cover will not close.



### 5.3.32 Gaining Access to the Expansion Box Card Cage

You must position the card cage on its side so you can remove the controller board and option boards.

1. Remove all external cables (Paragraph 5.3.1).
2. Separate the expansion box from the system unit (Paragraph 5.3.2).
3. Remove the expansion box cover (Paragraph 5.3.24).
4. Unplug the battery cable (Figure 5-50).
5. Disconnect the two signal cables from the hard disk drive controller board (Figure 5-50).
6. Tip the card cage on its side.

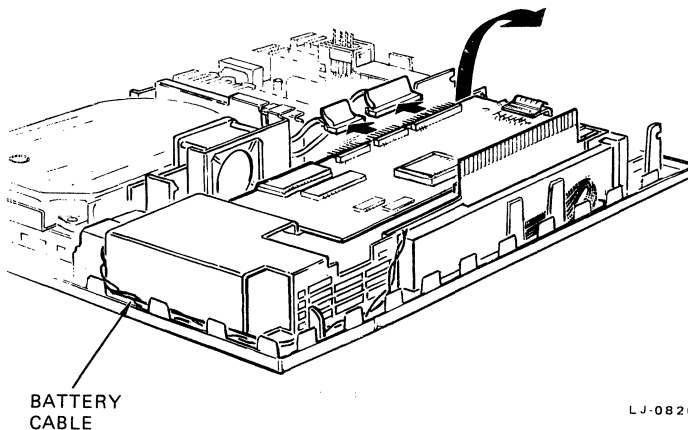
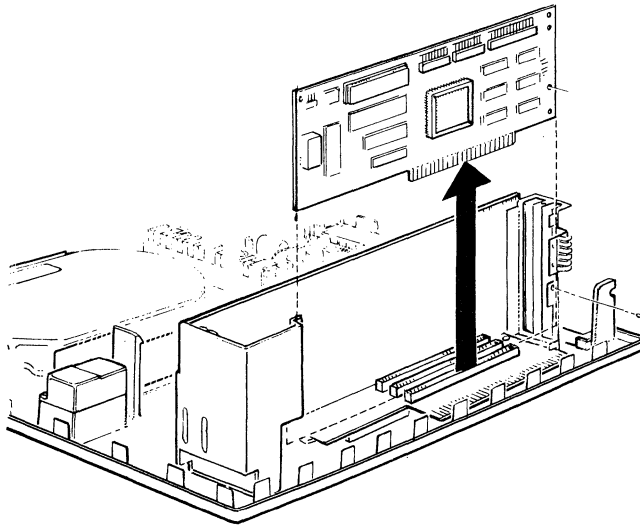

**Figure 5-50 Gaining Access to the Card Cage**



### 5.3.33 Hard Disk Controller Replacement

1. Gain access to the expansion box card cage (Paragraph 5.3.32).
2. Remove the three restraining screws that hold the controller board to the card cage.
3. Pull out the controller board (Figure 5-51).



LJ-0945

**Figure 5-51 Removing Hard Disk Controller**

4. Install the new hard disk controller board as follows.
  - a. Slide the board along the groove in to the cage.
  - b. Make sure the controller edge connector plugs firmly into the card cage backplane.
  - c. Install the three restraining screws that hold the controller board to the card cage.
  - d. Connect the two signal cables to the hard disk drive controller board.
  - e. Install the expansion box cover (Paragraph 5.3.24). Make sure there are no cables hanging outside the expansion box.



### 5.3.34 Option Replacement in the Expansion Box

1. Gain access to the expansion box card cage (Paragraph 5.3.32)
2. Remove any option board cable, if present (Figure 5-52).
3. Remove the option board restraining screw (Figure 5-52).
4. Remove the option board (Figure 5-52).
5. Install the new option board.
6. Connect any option board cable, if present.

**NOTE**

When you install an option board in the expansion box, make sure the jumper on the modem board is configured correctly. The jumper must connect pins 1 and 2. (See Figure 5-11.)

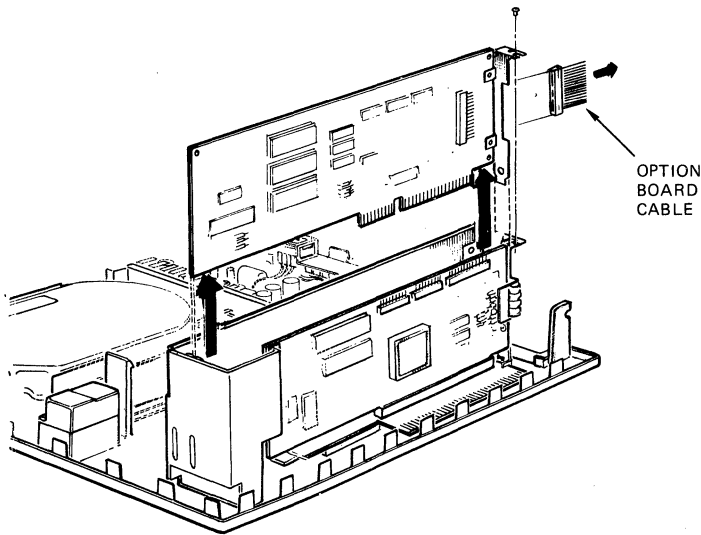

LJ-0821A

**Figure 5-52 Removing Option Board**



### 5.3.35 Option Backplane Replacement

1. Gain access to the expansion box card cage (Paragraph 5.3.32).
2. Remove the hard disk controller board (Paragraph 5.3.33).
3. Remove any option boards present in the card cage (Paragraph 5.3.34).
4. Remove the battery cable from its restraining tabs on the card cage.
5. Remove the four backplane holding screws (Figure 5-53) and remove the back shield from the card cage.

#### **NOTE**

Note the position of the small metal strip that has tabs to ground options installed in the backplane. On reassembly, the tabs do not touch the backplane. They are 135° away from the back of the backplane.

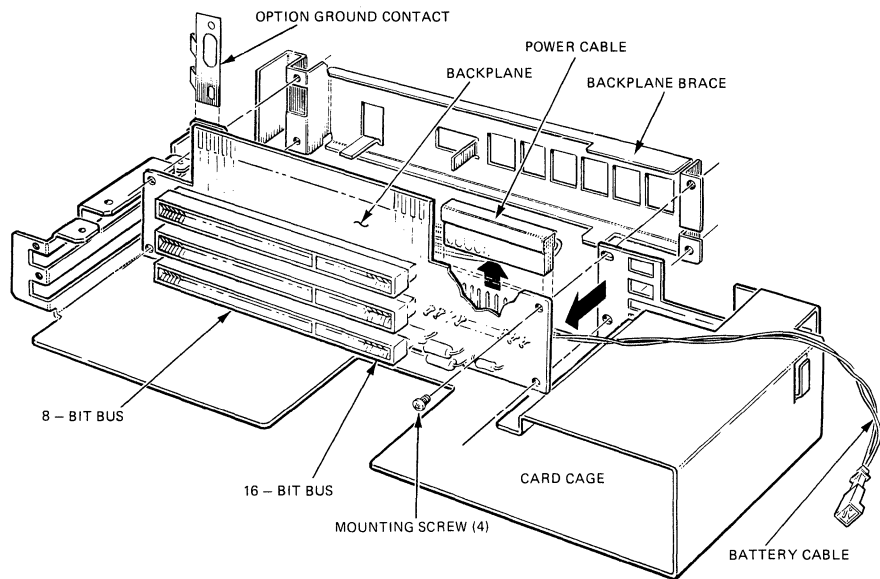

LJ-0947A

**Figure 5-53 Removing Backplane**



6. Unplug the power regulator cable from the backplane.
7. Install the new option backplane.
8. After reassembling the backplane and expansion box, place the system unit on top and connect all cables. Then, toggle the power switch and run the Extended Self-Test (Paragraph 2.24).

### **5.3.36 Expansion Box Fan Replacement**

1. Remove all external cables (Paragraph 5.3.1).
2. Separate the expansion box from the system unit (Paragraph 5.3.2).
3. Remove the expansion box cover (Paragraph 5.3.24).
4. Disconnect the 2-wire fan power connector from the power regulator connector.
5. Remove the fan assembly by removing one flat head screw and loosening a captive screw. Lift the fan assembly straight up (Figure 5-54).
6. Remove the fan from the fan assembly by removing the four restraining screws.

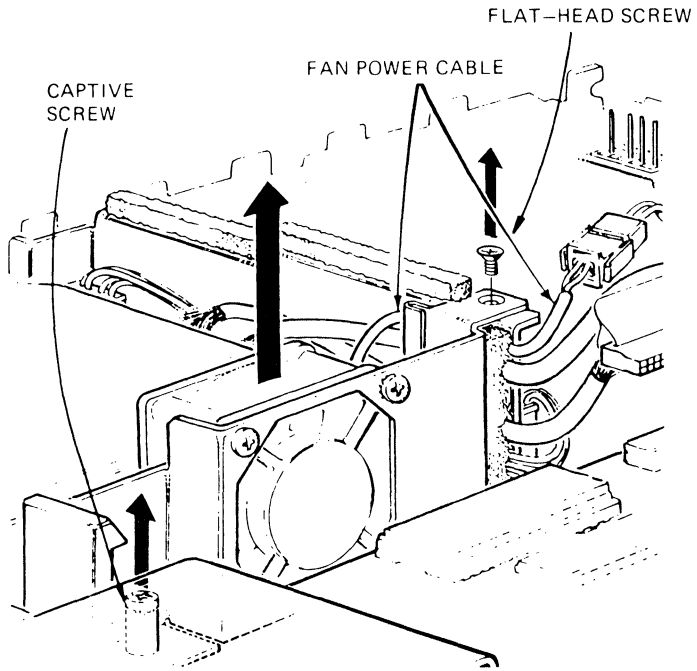

LJ 1430A

**Figure 5-54 Removing Fan**





### **5.3.37 Expansion Box Power Connector and Bridge Replacement**

Replace the power connector if the pins are bent or damaged, as follows.

1. Remove all external cables (Paragraph 5.3.1).
2. Separate the expansion box from the system unit (Paragraph 5.3.2).
3. Remove the expansion box cover (Paragraph 5.3.24).
4. Remove the screw that holds the bridge to the center of the power regulator (Figure 5-55).
5. Remove the two white ceramic resistors from the bridge. (If present, cut any tie wraps.)
6. Unplug the power connector cable from the bottom of the bridge.
7. If pins are bent or damaged, use a flat-blade screwdriver to push against the power connector so it falls out of its housing.
8. Install a new power connector, making sure the single pin is toward the outside near the screw hole.
9. Install the bridge; be sure to install the white ceramic resistors in the bridge and secure with tie wraps if any were removed. The bridge is the heat sink for the resistors.

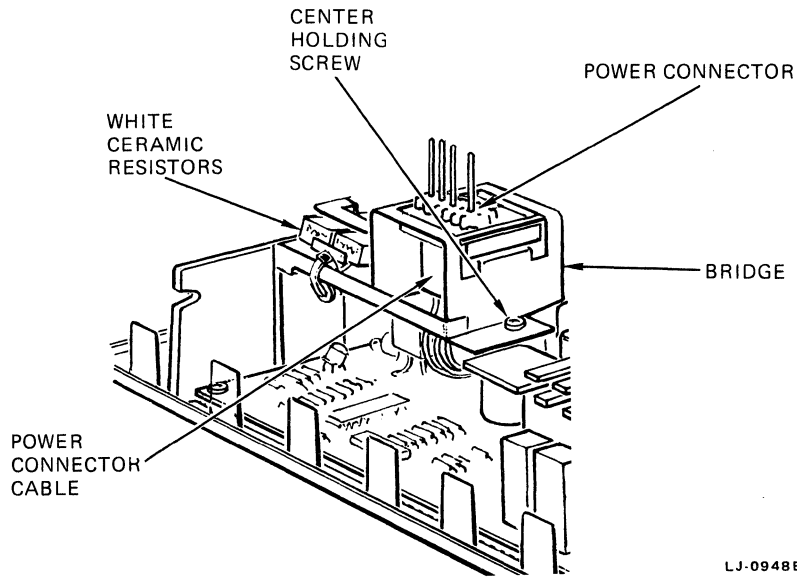

**Figure 5-55 Removing Bridge and Power Connector**



### **5.3.38 Expansion Box Power Regulator Replacement**

The power regulator board is labeled EXP BOX POWER SUPPLY in the expansion box.

1. Remove the expansion box power connector bridge (Paragraph 5.3.37).
2. Unplug the fan power cable connector (Figure 5-56) if present.
3. Unplug the two signal cables from the hard disk controller board.
4. Unplug any option cables.
5. Unplug the battery cable connector.
6. Tip the card cage on its side.
7. Remove the following screws and cables from the power regulator board (Figure 5-56).
  - Flat black cable
  - 4-wire power cable
  - Four mounting screws
8. Remove the power regulator board.
9. Install the new power regulator board. Make sure to install the two white resistors in the bridge; add a tie wrap to secure them if one was removed.

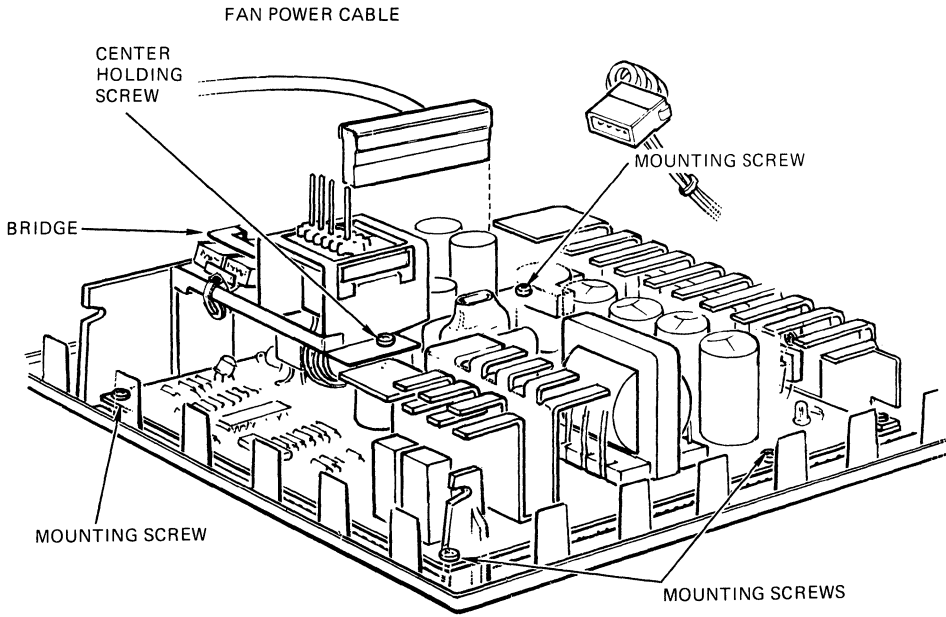

LJ-0948A

**Figure 5-56 Power Regulator Board**



### 5.3.39 Battery Replacement

1. Open the expansion box (Paragraph 5.3.24).
2. Disconnect the battery cable connector (Figure 5-57).
3. Remove the screw from the battery enclosure.
4. Remove the battery enclosure.
5. Remove the batteries.

**WARNING**

Do not dispose of the batteries at the customer site. Do not burn the batteries and do not take them apart.

6. Replace the batteries. Remember to reconnect the battery cable.

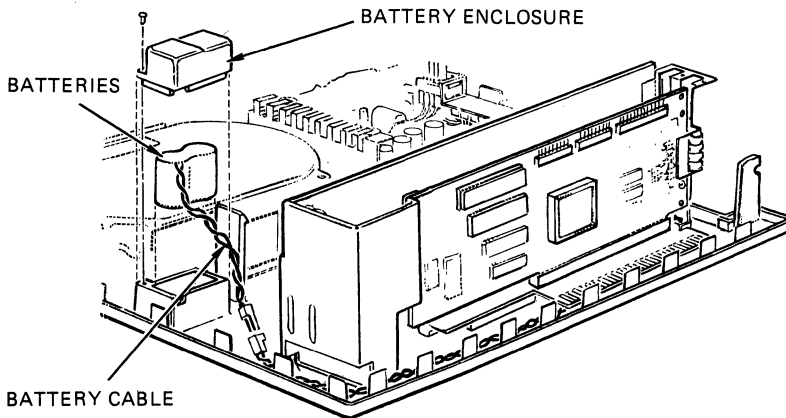

LJ-0931

**Figure 5-57 Replacing Battery**



### 5.3.40 Keyboard Replacement

1. Disconnect the keyboard cable from the system unit.
2. Connect the keyboard cable of the new keyboard to the system unit.

### 5.3.41 Mouse Replacement

1. Disconnect the mouse cable from the system unit.
2. Connect the mouse cable of the new mouse to the system unit.

Periodic cleaning of the mouse wheel with water prevents lint and gum buildup (Figure 5-58).

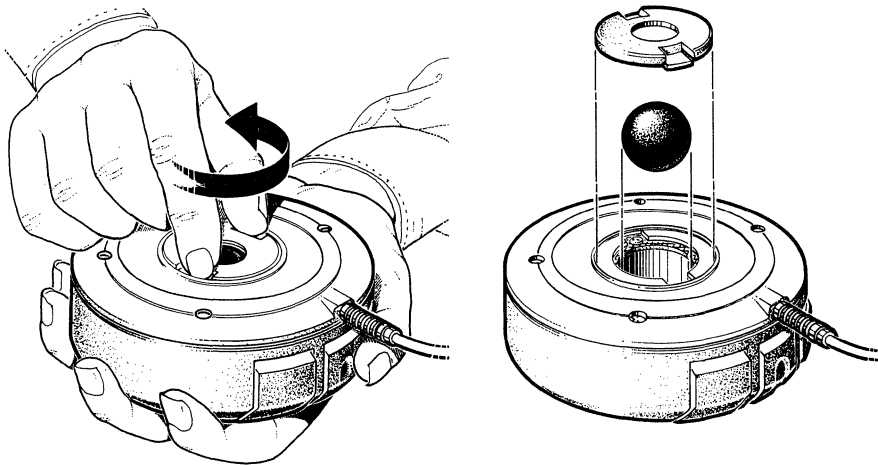

LJ-1476

**Figure 5-58 Mouse Cleaning**



# *Appendix A*

## *Part Numbers*

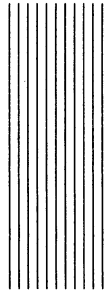

The parts and part numbers for the VAXmate Workstation and ThinWire network are listed in this appendix.

- Table A-1 VAXmate Workstation Recommended Spares
- Table A-2 Printer Components
- Table A-3 Base System
- Table A-4 Networking Components
- Table A-5 Country Specific Components





**Table A-1 VAXmate Workstation Recommended Spares**

| <b>Description</b>                                   | <b>Part Number</b> |
|--|--------------------|
| <b>Workstation</b>                                   |                    |
| New CPU and grounding kit, which include:            | PC500-UA           |
| – New CPU board                                      | 54-17187           |
| – Ground strap (braided)                             | 70-24726-01        |
| – Thermal shield                                     | 70-24727-01        |
| CPU board (old board with no ground wire)            | 54-16847-01        |
| I/O-Video board                                      | 70-23297-01        |
| Monitor board  | 54-16828-01        |
| CRT/yoke, bezel assembly (green)                     | 70-23300-01        |
| CRT/yoke, bezel assembly (amber)                     | 70-23300-02        |
| Power supply board (120 V 60 Hz)                     | 54-16861-01        |
| Power supply board (240 V 50 Hz)                     | 54-16861-02        |
| Diskette drive (RX33-A)                              | RX33-A             |
| Cable assembly                                       | 70-23308-01        |
| LED/cable assembly                                   | 17-01190-01        |
| RX power cable                                       | 17-00342-03        |
| RX data cable  | 17-01187-01        |
| CRT harness assembly                                 | 70-23307-01        |
| Keyboard (U.S. version)                              | LK250-xx           |
| Mouse (30-25322-01)                                  | VSXXX-xx           |
| Power cord (U.S. version)                            | 17-00606-02        |
| 2 Mbyte memory option board (PC50X-AA)               | 54-16853-AF        |
| Modem board option (U.S. and Canada only) (PC50X-MA) | 54-16881-01        |
| Math coprocessor option (80287)                      | FP287              |
| Local Area Network (LAN) cable                       | 17-01241-01        |
| Fuse (120 V)   | 90-07999-00        |
| Fuse (240 V)   | 12-23192-08        |
| Front bezel assy (diskette drive door and front LED) | 70-23298-01        |
| Speaker  | 70-23308-01        |

**Table A-1 VAXmate Workstation Recommended Spares (cont.)**

| Description   | Part Number |
|---|-------------|
| <b>Expansion Box</b>                                      |             |
| RD31 hard disk drive (20 Mbyte)                           | RD31-EA     |
| RD32 hard disk drive (40 Mbyte)                           | RD32-A      |
| RCD31-E hard disk drive controller board                  | RCD31-E     |
| RD data cable (20 pin), round                             | 17-01577-01 |
| RD data cable (34 pin), round                             | 17-01578-01 |
| RD power cable (4 pin)                                    | 17-00342-10 |
| Power regulator, 47 watt                                  | H7271-00    |
| Option backplane assembly                                 | 54-16849-01 |
| Backplane cable, 13 conductor                             | 17-01189-01 |
| Lithium battery/cable assembly, 6V (pair)                 | 12-25512-01 |
| Expansion Box Power Connector                             | 12-25671-01 |
| Fan bracket assembly*                                     | 70-24499-01 |
| Ground wire, 18 ga. black*                                | 70-24502-01 |
| <b>Special Tools and Test Components</b>                  |             |
| Metric tape measure                                       | 29-25342-00 |
| Anode discharge tool                                      | 29-24717-00 |
| 25-pin D-Sub loopback connector (for communications port) | 12-15336-06 |
| MMJ loopback connector (for printer port)                 | 12-25083-01 |
| Mouse loopback connector (for mouse port)                 | 12-25628-01 |
| BNC T-connector   | 12-25534-01 |
| BNC terminator, 50 ohm                                    | 12-25535-01 |
| Barrel connector  | 12-25567-01 |

\* Part is for -FA, -FC versions only.



*Part Numbers*

**Table A-2 Printer Components**

| <b>Description</b>                        | <b>Part Number</b> |
|---|--------------------|
| Printer option (LA75)                     | LA75-A2            |
| LA75 printer cable                        | BC16E-xx           |
| LA75 printer cable (shielded for Germany) | 17-01364-01        |

**Table A-3 Base System**

| <b>Description</b>  | <b>Part Number</b> |
|---|--------------------|
| System Unit with power supply and green or amber CRT – country specific | PC500-xx           |
| Keyboard – country specific   | LK250-xx           |
| Power cord – country specific   | BN19x-xx           |
| Mouse   | VSXXX-AA           |
| ThinWire LAN cable assembly kit that consists of:                       | PC50X-CB           |
| Cable   |                    |
| T-connector   |                    |
| Terminator (50 ohm)   |                    |
| <i>VAXmate User Handbook</i> (country specific)                         | —                  |
| Blank diskette  | RX33K-01           |

**Table A-4 Networking Components**

| <b>Description</b>                             | <b>Part Number</b> |
|--|--------------------|
| Local Area Network (LAN) cable                 | 17-01241-01        |
| ThinWire cable, PVC (6 feet)                   | BC16M-06/DA        |
| ThinWire cable, PVC (15 feet)                  | BC16M-15/DA        |
| ThinWire cable, PVC (30 feet)                  | BC16M-30/DA        |
| ThinWire cable, PVC (1000 feet spool)          | H8243-A/DA         |
| ThinWire cable, Teflon™ (1000 feet spool)      | H8244-A/DA         |
| ThinWire Ethernet male coaxial connector (BNC) | H8222/DA           |
| ThinWire Ethernet T-connector                  | 12-25534-01        |
| ThinWire Ethernet barrel connector             | H8224/DA           |
| ThinWire Ethernet terminator (50 ohm)          | 12-25535-01        |
| ThinWire Ethernet installation kit             | H8242/DA           |
| DIGITAL ThinWire Ethernet station adapter      | DESTA-AA/DA        |
| DIGITAL ThinWire Ethernet multiport repeater   | DEMPR-AA/DA        |

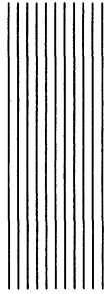

Table A-5 Country Specific Components

| Country                                | Keyboard | Power Cord | DIGITAL Power Cord Part Number | System Unit          | CRT Green | CRT Amber |
|--|----------|------------|--------------------------------|----------------------|-----------|-----------|
| U.S.                                   | LK250-AA | BN19P-1K   | 17-00606-02                    | PC500-BA<br>PC500-CA | X         | X         |
| Canada                                 | LK250-AA | BN19P-1K   | 17-00606-02                    | PC500-BQ<br>PC500-CQ | X         | X         |
| English speaking outside North America | LK250-AA | BN19A-2E   | 17-00209-08                    | PC500-BE<br>PC500-CE | X         | X         |
| French                                 | LK250-AP | BN19C-2E   | 17-00199-12                    | PC500-BP<br>PC500-CP | X         | X         |
| German                                 | LK250-AG | BN19C-2E   | 17-00199-12                    | PC500-BG<br>PC500-CG | X         | X         |
| French Canada                          | LK250-AC | BN19P-1K   | 17-00606-02                    | PC500-BC<br>PC500-CC | X         | X         |
| Canada (bilingual)                     | LK250-ED | BN19P-1K   | 17-00606-02                    | PC500-FD<br>PC500-GD | X         | X         |
| Italy                                  | LK250-AI | BN19M-2E   | 17-00364-08                    | PC500-BI<br>PC500-CI | X         | X         |
| French Swiss                           | LK250-AK | BN19E-2E   | 17-00210-05                    | PC500-BK<br>PC500-CK | X         | X         |
| German Swiss                           | LK250-AL | BN19E-2E   | 17-00210-05                    | PC500-BL<br>PC500-CL | X         | X         |
| Finland                                | LK250-AF | BN19C-2E   | 17-00199-12                    | PC500-BF<br>PC500-CF | X         | X         |
| Denmark                                | LK250-AD | BN19K-2E   | 17-00310-05                    | PC500-BD<br>PC500-CD | X         | X         |
| Norway                                 | LK250-AN | BN19C-2E   | 17-00199-12                    | PC500-BN<br>PC500-CN | X         | X         |
| Sweden                                 | LK250-AM | BN19C-2E   | 17-00199-12                    | PC500-BM<br>PC500-CM | X         | X         |
| Israel                                 | LK250-AT | BN19U-2E   | 17-00457-08                    | PC500-BT<br>PC500-CT | X         | X         |
| Australia/<br>New Zealand              | LK250-AA | BN19H-2E   | 17-00198-07                    | PC500-BZ<br>PC500-CZ | X         | X         |

# *Appendix B*

## *Test Descriptions*



### **B.1 Introduction**

This Appendix lists all the Service Diagnostic tests. The tests are listed in the same order as they appear on the Individual Test menu. The system test mode runs a subset of the individual tests – not all the hardware is tested.

Many of the individual tests are interactive. The tests vary in length from several seconds to 25 minutes. The longest tests are as follows.

- 01 Memory
- 02 Comm
- 06 Printer
- 07 Mouse
- 08 Event Timer
- 14 Option Memory
- 15 System Interaction
- 19 Local Network Link

The system test is not interactive, however, you must install the loopback connectors before running the test.



## **01 MEMORY TEST**

This test checks the 1 Mbyte of memory on the CPU board. The memory consists of two memory modes: real (768 Kbytes) and protected (256 Kbytes). For both the real and protected memory, the memory test does the following.

- Verifies the parity generator circuitry and nonmaskable interrupt (NMI) circuitry.
- Functionally tests the dynamic memory by using the moving inversions algorithm.
- Verifies that each location can generate parity.
- Verifies address line A20, the selectable address. If the A20 test is unsuccessful, the remaining protected mode tests are discontinued.

During part of the test, there is no screen activity. This occurs when the test, operating system, and other resident code are moved to a different location in memory so that all memory can be tested.

## **02 COMM PORT TEST**

This test offers internal or external testing of the communications port. External testing requires the communications port loopback connector. Both internal and external testing check that the communications port can:

- Loop back all signals off board (external test only).
- Generate all four types of interrupts: modem status, transmit empty, receive available, receiver line status.
- Detect all types of error conditions.
- Detect and force all parity conditions.
- Transmit and receive at all specified baud rates (timed) from 50 to 19200.
- Transmit and receive all combinations of data sizes, stop bits, using 256 characters for individual test mode, and only 10 characters for system test mode.
- Verify split baud.

In system test mode, only external testing is performed. Testing starts at 1200 baud.



### **03 VIDEO TEST**

This test checks the following functions.

- Display memory and font RAM using a moving inversion algorithm.
- Video modes not supported by BIOS. The IRGB (intensity, red, green, blue) data is compared to known values. IRGB values translate to shades of gray.
- The functionality of the video gate array and memory mapping.
- Reading from and writing to the diskette to verify the functionality of the video gate array and video bus arbitration circuitry.

The video test requires that you use the formatted high density scratch diskette provided in the Maintenance Kit during specific tests. Some of the subtests prompt you for visual verification.

The video test is not performed if a video option (or graphics board) is detected in the expansion box. An error is logged, however. To run the video test, remove the video option from the expansion box.

To test the monitor board, display the video alignment patterns in test number 13.

### **04 DISKETTE DRIVE TEST**

This test writes to the diskette. Make sure to use the high-density formatted scratch diskette included in the Maintenance Kit. The diskette drive test:

- Verifies the operation of the diskette drive and all associated circuitry on the I/O board.
- Checks the mechanical performance of the drive.
- Checks the discrete functions of the diskette controller.
- Checks the ability of the diskette drive subsystem to function correctly as an integral part of the VAXmate system.
- Performs read/write tests on a scratch diskette





This test requires either the formatted high- or low-density scratch diskette, included in the Maintenance Kit, depending on which media you want to test. The test prompts you when to change diskettes. During the test, the abbreviation FDC (floppy disk controller) displays on the screen.

A large number of soft errors shown in the error log can indicate a performance problem. Make sure the heads are clean and the diskette has no errors.

### **05 SPEAKER TEST**

The speaker tests check the speaker and speaker driver circuit. Many of the tests produce audio tones that you must verify are correct. Some of the tests are quite loud. If XXXXXX is displayed during this test, you must decide if the test passed or failed.

### **06 PRINTER PORT TEST**

This test offers internal or external testing of the printer port. External testing requires the printer port loopback connector. Both internal and external testing check that the printer port can:

- Loop back all signals off board (external test only).
- Generate all four types of interrupts: printer status, transmit empty, receive available, and receiver line status.
- Detect all types of error conditions.
- Detect and force all parity conditions.
- Transmit and receive at all specified baud rates (timed) from 50 to 19200.
- Transmit and receive all combinations of data sizes, stop bits, using 256 characters for individual test mode, and only 10 characters for system test mode.

In system test mode, only external testing is performed. Testing starts at 1200 baud. If an 8250 fault occurs, this test may loop on itself. Obtain a new version of the diagnostic and retest.



## 07 MOUSE TEST

This test checks:

- The circuitry on the CPU board relating to communication with the mouse. This includes UART baud rates in either internal or external loopback mode, interrupt capability, and internal registers.
- The functionality of the DIGITAL standard mouse. This includes mouse self test, mouse communications, button tests, and a functional position test. The functional position test is skipped if a video option is detected in the expansion box. Remove the option to run the test.

You are prompted to use the mouse or mouse loopback connector. Choose either of these if you select continuous pass testing.

Non-DIGITAL mice are not tested.

In system test mode, only external testing is performed. Testing starts at 1200 baud.

## 08 EVENT TIMER TEST

This test verifies the CMOS RAM and the functionality of the event counters. When the test is complete, the date and time are not valid. Therefore it is necessary to reset the date and time. The goal of the tests is to make sure the event timer can:

- Keep precise time.
- Interrupt every second (when the counter update occurs).
- Periodically interrupt at all selectable time intervals.
- Interrupt when an alarm condition is detected.
- Count seconds, minutes, hours, days of the week, date, month and year.
- Represent time, calendar, and alarm in binary or BCD.
- Keep a 12- or 24-hour clock; a.m. and p.m. are in 12-hour mode.
- Change to daylight savings time.
- Recognize the end of the month.
- Compensate for leap year.



## **09 NETWORK TESTS**

The network tests check the VAXmate Ethernet logic circuitry and also test the ThinWire cable for opens and correct termination. You can also test the cable and its connectors for shorts, however, you do not need to run the Service Diagnostics for this. Follow these steps to run the network tests.

1. Test the VAXmate Ethernet logic circuitry as follows.
  - a. Plug in the network port loopback connector as shown in Figure B-1, example 1. Make sure there is a 50-ohm terminator at each arm of the T-connector. To assemble the network port loopback connector see Figure 2-15 in Chapter 2.
  - b. Run test 09.
2. Test the ThinWire cable for opens and for correct termination as follows.
  - a. Configure the VAXmate workstation as shown in Figure B-1, example 2.
  - b. Run test 09.
3. Test the ThinWire cable and the T-connectors for shorts as follows. You need an ohmmeter with a times 1 scale.
  - a. Assemble the cable and connectors as shown in Figure B-1, example 3. Figure B-1 shows a 50-ohm terminator at each end. However, you can also test with just one terminator.
  - b. Connect the ohmmeter at the points shown. The ohmmeter reading should be as follows:
    - 25 ohms if there is a terminator at each end
    - 50 ohms if there is a terminator at one end only
  - c. If you do not get one of these values, run the test again with a different cable. Replace the cable or T-connectors, depending on the results of the ohmmeter test.



EXAMPLE 1 TESTING VAXmate ETHERNET LOGIC CIRCUITRY

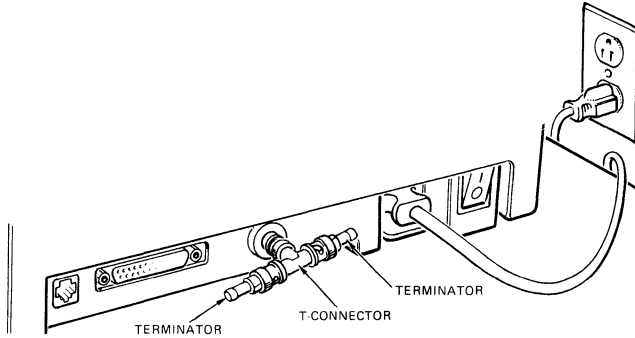

EXAMPLE 2 TESTING FOR OPENS AND TERMINATION

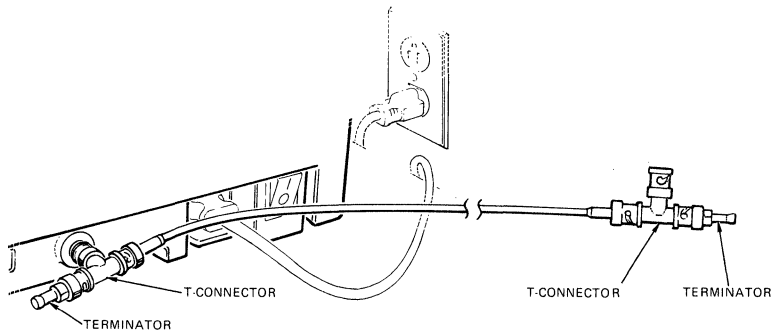

EXAMPLE 3 TESTING FOR SHORTS

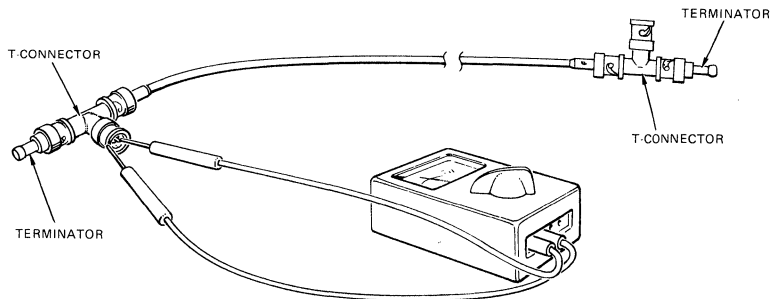

LJ-0949

Figure B-1 Network Test Configurations Examples 1, 2, and 3



## **10 80287 TESTS**

The first test checks for the presence of the math coprocessor (80287). If the 80287 coprocessor is not found, or does not respond correctly, a message displays and testing is discontinued. If the 80287 coprocessor is found, its ability to do the following is tested.

- Generate an interrupt
- Access memory and communicate with the 80286
- Control its internal stack
- Read and write all stack and environment registers
- Generate exceptions
- Support data types
- Execute a subset of its instruction set

## **11 KEYBOARD TEST**

Many of the keyboard tests are interactive. To terminate many of the interactive subtests press the **ALT/F10** keys. This test checks the following.

- Keyboard interface processor and its interrupt capability.
- Industry-standard and DIGITAL extended and reserved commands.
- The four keyboard LEDs. The LEDs are initially off. You are prompted to type a key to turn on the LEDs.
- The four volume levels of keyclicks. A keyclick is sent to the keyboard speaker when you type a key. The clicks increase in volume as you continue to press keys.
- Autorepeat rate timing.
- Autorepeat delay timing. This tests all possible delay rates (250, 500, 750, or 1000 msec).
- Key functionality. A picture of the keyboard is displayed on the screen and you press keys to make sure they are functioning.



## 12 PRINTER CONFIDENCE TEST

This checks the functionality of the printer, if present. First the required configuration of the printer is displayed, then a menu is displayed from which you can choose text entry, default message, or last message printed.

If you choose text entry, the screen clears so you can type in your text. To stop text entry and send this text to the printer, press the F10 key. Selecting either of the other options causes the selected text to be immediately printed. Use the number keys to select menu items.

## 13 VIDEO ALIGNMENT PATTERNS

The video alignment patterns are for the monitor subsystem adjustments. There is a menu from which you can select each pattern. Refer to chapter 4, Monitor Adjustments. Press the F10 key to exit the video alignment patterns.

Visually verify that all the video alignment patterns produce a stable display. If any of the patterns do not look correctly displayed, there may be a problem with the monitor board.

The patterns are as follows. (These are not displayed if a non-VAXmate video is present.)

- Full screen intensity level 2 (blue)
- Full screen intensity level 4 (red)
- Full screen intensity level 8 (green)
- Full screen intensity level 14 (white)
- Intensity level 0 to 15 from left to right
- Screen of E's with solid border (400 scan line mode)
- Screen of E's with solid border (250 scan line mode)
- Grid/Circle

## 14 OPTION MEMORY TEST

This test checks the DIGITAL 2 Mbyte memory option. The test performs:

- A functional check of the parity generator circuitry and NMI circuitry.
- A test of each memory location's ability to generate parity.
- A moving inversions pattern test on all option memory.
- A unique address test to verify that the full 2 Mbyte memory is accessible.



## **15 SYSTEM INTERACTION TEST**

This Test initiates several processes at the same time to create a worst case condition for system operation. This test ensures that each hardware subsystem is being allocated the appropriate CPU time and completes its process within a certain time. The system configuration is checked to determine what processes may be started up on the system under test. The processes are initiated in the following order.

Options (modem, 80287, and hard disk)

Main board (CPU, event timer, and mouse)

I/O board (communications, printer, diskette, and network)

The test begins by displaying the system configuration necessary for testing, followed by a warning about diskette data being destroyed. All loopback connectors and a scratch diskette are needed for this test. The system Interaction Execution Menu is then displayed. The menu lists each process with a description of what that process does. The description is only present for options that are found to be present. The word **ACTIVE** is displayed on the screen for each process that is currently running. This **ACTIVE** indication should be used to determine what hardware was currently running when an error occurs, indicating what hardware was involved in the interaction problem. Note that testing stops after the first error is detected, since it is impossible to resume operation from the error.

A **PROCESS PROGRESS** error message indicates that one of the hardware subsystems did not receive the expected amount of CPU time. The intermediate progress of all processes is checked about every 2 minutes. The test takes about 10 minutes to complete.

You can abort the test by pressing the **Ctrl** and **PF3** keys at the same time. Note that since the keyboard is running a process of its own, you might get an error attributed to breaking out of the test.

### ***NOTE***

Since many of the errors in this test are caused by the interaction of one or more hardware subsystems, replacing the designated FRU may not eliminate the problem. Therefore, it is up to the service technician to judge what FRU or FRUs can be causing the problem. The circuitry experiencing the interaction problem is listed in the error description.



## **16 HARD DISK TEST**

This test determines if a hard disk and hard disk controller are present. If present, the tests check:

- Controller registers.
- Controller reset functions.
- Controller internal diagnostic function.
- Hard disk recalibration.
- Read-verify of the entire disk.
- Heads, cylinders, and sectors verification of entire media.
- Read/write functions on the disk diagnostic cylinders.
- Seek and motor speeds.
- Forced error conditions.
- Random seek.

If either the hard disk or controller is not present, a message and an error is displayed. Testing is discontinued, and an error is also logged. When any error condition is corrected by a retry, a 1650 code is reported.

## **17 MODEM TEST**

This test determines if a DIGITAL-supported modem is present. If there is no modem, or if the modem is not supported by DIGITAL, the modem tests are discontinued and a message is displayed. If a DIGITAL-supported modem is present, the following is tested.

- Registers
- Interrupts
- Data Transmission and reception at various baud rates, data bits and parity settings (the baud rates are timed)
- Modem command mode with internal self-test

There is an optional external loopback test. This prompts you to make a telephone line modem connection to another VAXmate that has a known operational modem. The modem at the other VAXmate, called the remote modem, must be set to 1200 baud and must also be set to autoanswer. Exiting this test before it completes may leave the modem in a wrong state.





## 18 PARK DRIVES

Always run this program when you want to move the system unit and, if present, expansion box. This program does not test the drives, but places the diskette drive head and hard disk drive head in position for transport. The number of each drive is displayed and its passed/failed (parked/not parked) status. If the drives pass, you are instructed to turn off the system and prepare it for transport. If the drives fail, you are instructed to run the corresponding diagnostics.

## 19 LOCAL NETWORK LINK TEST (VAXmate to VAXmate)

This test exercises the network circuitry in a busy network traffic environment. As much activity as possible is created between two VAXmate workstations. A third VAXmate workstation can be added to increase network traffic. See Figure B-2 to configure two VAXmate workstations.

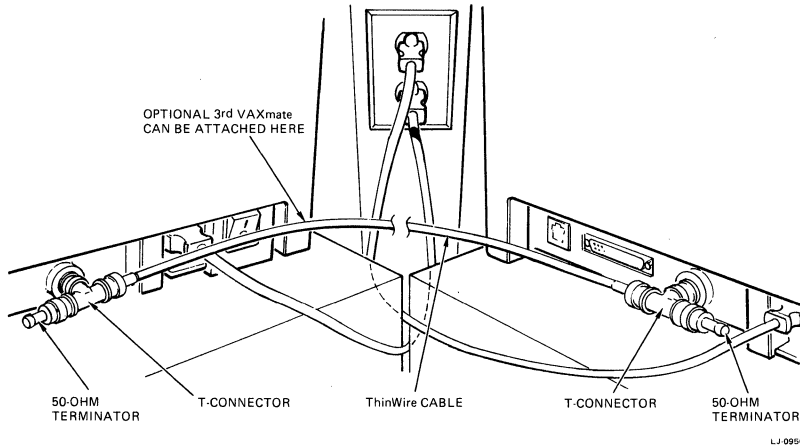

**Figure B-2 Local Network Link Test Configuration**



To add a third VAXmate workstation, see Chapter 3, Paragraph 3.5.4, Adding a VAXmate Workstation to the Middle of a Segment. This test takes about 10 minutes per pass to run. It takes longer to run if more than two VAXmate workstations are connected.

**NOTE**

These VAXmate systems must not be connected to any DEMPR or DESTA.

To run this test, one VAXmate must be in echo mode, and the other(s) in transmit mode. Run the Local Network Link Test as follows:

1. Start test 19 on all VAXmates.
2. Start the known good VAXmate in echo mode.
3. Select transmit mode on the remaining VAXmate(s).

The known good VAXmate system should be in echo mode; the system to be tested should be a transmitter; and a third system can be introduced as a transmitter. The test prompts you to choose the mode. When you choose echo mode, the test displays the node address. You must type in this node address on the VAXmates that are acting in transmit mode.

Shut down the test as follows.

1. Let the transmitter complete the selected number of passes.
2. Press the **Ctrl** and **PF3** keys at the same time to stop echo mode from running.



# Appendix C

## Error Numbers

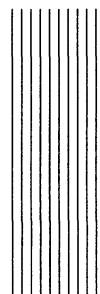

Appendix C has error numbers, with FRUs and error messages, that can occur during troubleshooting. The information is listed in four tables.

- Table C-1 ROM Diagnostic Error Numbers – lists the 2-digit error numbers and corresponding FRUs to check or replace for the Power-Up test and Extended Self-Test. Make sure to check the cables and connections before you replace any FRUs. The expansion box runs off of the CPU board and may cause CPU problems.
- Table C-2 Service Diagnostic Error Numbers – lists the 4-digit error numbers and the corresponding FRUs to check or replace for the Service Diagnostic. Make sure to check the cables and connections before you replace any FRUs.
- Table C-3 Install Diagnostic Error Messages – lists the error messages that can occur during mode 3, Install New Diagnostics, of the Service Diagnostics. The corrective action follows the error message.
- Table C-4 System Error Messages – lists the messages that can occur at any time while using the Service Diagnostics.

**Table C-1 ROM Diagnostics Error Numbers**

| <b>Error Number</b> | <b>FRU to Check or Replace</b> | <b>Failing Test</b>        |
|---------------------|--------------------------------|----------------------------|
| 00                  | CPU board                      | Basic CPU board test       |
| 01                  | CPU board                      | Memory tests               |
| 02                  | CPU board                      | Memory parity test         |
| 03                  | -                              | Reserved                   |
| 04                  | CPU board                      | Unexpected interrupts      |
| 05                  | CPU board                      | Unexpected NMIs (parity)   |
| 06                  | CPU board                      | ROM checksum test          |
| 07                  | CPU board                      | Protected mode memory test |
| 08                  | CPU board                      | 8042 tests                 |



**Table C-1 ROM Diagnostics Error Numbers (cont.)**

| <b>Error Number</b> | <b>FRU to Check or Replace</b> | <b>Failing Test</b>                                    |
|---------------------|--------------------------------|--|
| 09                  | CPU board                      | Refresh delay test (30 seconds)                        |
| 0A                  | CPU board                      | Exception interrupt (protected mode)                   |
| 0B                  | CPU board                      | Keyboard interrupt test                                |
| 0C                  | CPU board                      | System status register test                            |
| 0D                  | CPU board                      | Ethernet ROM checksum                                  |
| 10                  | CPU board                      | Timer tests  |
| 11                  | CPU board                      | Master interrupt controller tests                      |
| 12                  | CPU board                      | DMA controller tests                                   |
| 13                  | CPU board                      | Numeric processor extension tests (80287)              |
| 14                  | CPU board                      | Mouse UART internal tests                              |
| 15                  | CPU board                      | Mouse UART external loopback tests                     |
| 16                  | CPU board                      | Slave interrupt controller tests                       |
| 17                  | CPU board                      | Event timer tests                                      |
| 18                  | CPU board                      | Mouse interrupt test                                   |
| 19                  | CPU board                      | Diskette DMA above 1 Mbyte test                        |
| 1A                  | CPU board                      | Quick CPU shutdown circuitry test                      |
| 20                  | I/O board                      | Printer port tests                                     |
| 21                  | I/O board                      | Printer loopback tests                                 |
| 22                  | I/O board                      | Communication port tests                               |
| 23                  | I/O board                      | Communication loopback tests                           |
| 24                  | I/O board                      | Diskette controller tests                              |
| 25                  | I/O board                      | Local Area Network Controller (LANCE) sub-system tests |
| 26                  | I/O board                      | LANCE interrupt not received                           |
| 27                  | -                              | Reserved   |
| 28                  | I/O board                      | LANCE unexpected interrupt test                        |
| 29                  | I/O board                      | LANCE external loopback test                           |
| 2A                  | -                              | Reserved   |
| 2B                  | I/O board                      | LANCE CRC check  |
| 30                  | I/O board                      | Video memory access, data path tests                   |
| 31                  | I/O board                      | Video memory tests                                     |
| 32                  | I/O board                      | Video font tests                                       |
| 33                  | I/O board                      | Text mode tests  |
| 34                  | I/O board                      | Graphics mode tests                                    |
| 35                  | I/O board                      | Video register tests                                   |
| 36                  | I/O board                      | Video translation ROM tests                            |
| 37                  | I/O board                      | Horizontal/vertical synchronous tests                  |
| 38                  | I/O board                      | Color map tests (VLT)                                  |
| 39                  | I/O board                      | Video RAM refresh/data retention test                  |
| 40                  | Drive A                        | Recalibrate tests                                      |
| 41                  | Drive A                        | Step tests   |
| 42                  | Drive A                        | Seek tests   |



Table C-1 ROM Diagnostics Error Numbers (cont.)

| Error Number | FRU to Check or Replace | Failing Test                             |
|--------------|-------------------------|--|
| 43           | Drive A                 | Motor speed test                         |
| 44           | Drive A                 | Read test                                |
| 45           | Drive A                 | Not ready                                |
| 46           | Drive A                 | Seek with verify tests                   |
| 50           | Option memory           | Parity tests                             |
| 51           | Option memory           | Basic tests                              |
| 52           | Option memory           | Unexpected NMI (nonmaskable interrupt)   |
| 60           | Keyboard                | Keyboard reset test                      |
| 70           | Hard disk controller    | Interrupt/reset test                     |
| 71           | Hard disk controller    | Controller not present test              |
| 72           | Hard disk controller    | Controller port tests                    |
| 73           | Hard disk controller    | Internal diagnostics test                |
| 74           | Hard disk controller    | Initialization test                      |
| 80           | -                       | Reserved                                 |
| 81           | Hard disk drive 0       | Ready test                               |
| 82           | Hard disk drive 0       | Recalibration test                       |
| 83           | Hard disk drive 0       | Read test/unformatted drive              |
| 84           | Hard disk drive 0       | Extended read test                       |
| 85           | Hard disk drive 1       | Ready test                               |
| 86           | Hard disk drive 1       | Recalibration test                       |
| 87           | Hard disk drive 1       | Read test/unformatted drive              |
| 88           | Hard disk drive 1       | Extended read test                       |
| 90           | -                       | Reserved                                 |
| 91           | Modem                   | Asynchronous port power-up reset test    |
| 92           | Modem                   | Asynchronous port register test          |
| 93           | Modem                   | Asynchronous interrupt test              |
| 94           | Modem                   | Asynchronous parity test                 |
| 95           | Modem                   | Asynchronous baud test                   |
| 96           | Modem                   | Modem command test                       |
| 97           | Modem                   | Modem local analog loop and self-test    |
| 98           | Modem                   | Modem ROM test                           |
| 99           | Async card/modem        | Modem jumpers need to disable diagnostic |
| A0           | Option 2                | Reserved for future option               |
| B0           | Option 3                | Reserved for future option               |
| C0           | Option 4                | Reserved for future option               |
| D0           | Option 5                | Reserved for future option               |
| E0           | Option 6                | Reserved for future option               |
| F0           | Option 7                | Reserved for future option               |

**NOTE**

If you have installed a new option or disconnected the Expansion Box, remember to set the power switch to off, wait 15 seconds, and set the power switch to on, before running the Extended Self-Test.



**Table C-2 Service Diagnostics Error Numbers**

| <b>Error Number</b>   | <b>FRU to Check or Replace</b> | <b>Description</b>  |
|---|--------------------------------|---|
| <b>NOTE</b>   |                                |   |
| If the FRU to check or replace has a number after it, read the corresponding corrective action at the bottom of the page. |                                |   |
| <b>MEMORY SUBSYSTEMS ERRORS</b>   |                                |   |
| 0100  | CPU board                      | Parity generator not working properly                             |
| 0101  | CPU board                      | Memory location does not generate parity                          |
| 0102  | CPU board                      | Memory error during moving inversions test                        |
| 0103  | CPU board                      | Protected memory location does not generate parity                |
| 0104  | CPU board                      | Protected memory error during moving inversions test              |
| 0105  | CPU board                      | Protected memory exception interrupt occurred                     |
| 0106  | CPU board                      | Unexpected Nonmaskable Interrupt (NMI) occurred                   |
| 0107  | CPU board                      | Address line A20 not working                                      |
| <b>COMMUNICATION SUBSYSTEM ERRORS</b>   |                                |   |
| 0200  | I/O board                      | Faulty bit(s) in communications internal register                 |
| 0201  | I/O board                      | Incorrect status received when trying to transmit characters      |
| 0202  | I/O board                      | Incorrect status received when trying to receive characters       |
| 0203  | I/O board                      | No communication interrupt or incorrect interrupt status received |
| 0204  | I/O board                      | Parity test, data transmitted does not equal data received        |
| 0205  | I/O board                      | Parity test, an error condition occurred during a transmit        |
| 0206  | I/O board <sup>1</sup>         | Inability to loop back any signals off board (no loopback plug)   |
| 0207  | I/O board                      | Incorrect status received while transmit or receive               |
| 0208  | I/O board                      | Baud rate test, timeout – character transfer never completed      |
| 0209  | I/O board                      | Baud rate test, timing of current baud rate was out of spec       |

<sup>1</sup>Correct the problem as follows.

1. Reseat the communication loopback connector.
2. If the error number is displayed again, replace the loopback connector.
3. If that does not solve the problem, replace the I/O board.

**Table C-2 Service Diagnostics Error Numbers (cont.)**

| <b>Error Number</b>           | <b>FRU to Check or Replace</b> | <b>Description</b>   |
|-------------------------------|--------------------------------|--|
| 0210                          | I/O board                      | Baud rate test, data transmit does not equal data receive                        |
| 0211                          | I/O board                      | Bad status received from modem status register                                   |
| 0212                          | I/O board <sup>1</sup>         | Some signal(s) unable to be looped back off board                                |
| 0213                          | I/O board                      | Unable to clear pending characters or interrupts                                 |
| 0214                          | I/O board                      | Split baud circuitry failed  |
| <b>VIDEO SUBSYSTEM ERRORS</b> |                                |  |
| 0300                          | None <sup>2</sup>              | Foreign video detected, skipping all video tests                                 |
| 0301                          | I/O board                      | Video screen RAM failure   |
| 0302                          | I/O board                      | Video font RAM failure   |
| 0303                          | I/O board                      | 6845 not refreshing RAM or cell failure  |
| 0304                          | I/O board                      | DEC 4-color graphics mode: intensity, red, green, and blue (IRGB) check failure  |
| 0305                          | I/O board                      | Video to video DMA transfer failed   |
| 0306                          | I/O board                      | DEC 16 color graphics mode: intensity, red, green, and blue (IRGB) check failure |
| 0307                          | Diskette <sup>3</sup>          | DOS error while accessing diskette   |
| 0308                          | I/O board                      | Diskette to video RAM DMA read failure   |
| 0309                          | I/O board                      | Diskette to video DMA data comparison error                                      |
| 0310                          | I/O board <sup>3</sup>         | Video to diskette DMA write error  |
| 0311                          | I/O board                      | Diskette to video DMA read failure   |
| 0312                          | I/O board <sup>3</sup>         | Diskette/video DMA read/write data compare error                                 |
| 0313                          | Diskette <sup>3</sup>          | BIOS error while doing diskette initialization function                          |
| 0314                          | I/O board                      | Video look-up table RAM failure  |
| 0315                          | I/O board                      | Video gate array mapper failure  |

<sup>1</sup>Correct the problem as follows.

1. Reseat the communication loopback connector.
2. If the error number is displayed again, replace the loopback connector.
3. If that does not solve the problem, replace the I/O board.

<sup>2</sup>Correct the problem by removing the non-DIGITAL video board.

<sup>3</sup>Correct the problem as follows.

1. Try another formatted high density diskette.
2. If the test does not pass, then run the diskette test.
3. If the diskette test passes, replace the I/O board.





**Table C-2 Service Diagnostics Error Numbers (cont.)**

| <b>Error Number</b>       | <b>FRU to Check or Replace</b> | <b>Description</b>                              |
|---------------------------|--------------------------------|---|
| DISKETTE SUBSYSTEM ERRORS |                                |   |
| 0400                      | I/O board                      | Diskette controller failure                     |
| 0401                      | I/O board                      | Incorrect status returned by the FDC            |
| 0402                      | I/O board                      | Open or shorted data lines                      |
| 0403                      | I/O board                      | DMA-PII logic failure                           |
| 0404                      | I/O board                      | Drive status register error                     |
| 0405                      | Diskette A                     | Diskette drive unable to recalibrate            |
| 0406                      | Diskette A                     | Diskette drive unable to step off of track zero |
| 0407                      | Diskette A                     | Diskette drive step rate timing out of spec     |
| 0408                      | Diskette A                     | Diskette drive rotational speed out of spec     |
| 0409                      | Diskette A <sup>4</sup>        | Cyclic redundancy check (CRC) error             |
| 0410                      | Diskette A <sup>4</sup>        | Unable to read media                            |
| 0411                      | -                              | Reserved  |
| 0412                      | Diskette A <sup>4</sup>        | Soft error, media is write protected            |
| 0413                      | Diskette A <sup>4</sup>        | Data write error                                |
| 0414                      | I/O board                      | Soft error; FDC error detection logic failure   |
| 0415                      | Diskette A <sup>4</sup>        | Soft error; unable to detect end-of-track       |
| 0416                      | Diskette A <sup>4</sup>        | Soft error; unable to detect sector ID          |
| 0417                      | Diskette A <sup>4</sup>        | Unable to find specified track                  |
| 0418                      | Diskette A <sup>4</sup>        | Incorrect status returned during scan test      |
| 0419                      | Diskette A <sup>4</sup>        | Drive not ready                                 |
| 0420                      | I/O board                      | No interrupt generated by the FDC               |
| 0421                      | Diskette A                     | Close drive door                                |
| 0422                      | Diskette A <sup>4</sup>        | Index pulse not toggling                        |
| 0423                      | Diskette A <sup>4</sup>        | Soft error, diskette data incorrect             |
| 0424                      | Diskette A <sup>4</sup>        | Soft error, data over-run error                 |
| 0425                      | Diskette A <sup>4</sup>        | Control mark encountered                        |
| 0426                      | Diskette A                     | Drive A seek failure                            |
| 0427                      | I/O board                      | FDC unable to detect deleted data               |
| 0428                      | I/O board                      | FDC unable to detect control mark               |
| 0429                      | I/O board                      | Soft error, no data bit set                     |

<sup>4</sup>Correct the problem as follows.

1. Insert the diskette correctly.
2. If it is inserted correctly, try a different formatted high- or low-density diskette.
3. If the error number is displayed again, use a new version of the diagnostic diskette.
4. If error still occurs, replace the FRU.

**Table C-2 Service Diagnostics Error Numbers (cont.)**

| <b>Error Number</b>      | <b>FRU to Check or Replace</b> | <b>Description</b>   |
|--------------------------|--------------------------------|--|
| SPEAKER SUBSYSTEM ERRORS |                                |  |
| 0500                     | CPU board                      | Timer 2 output not generating waveform                           |
| PRINTER SUBSYSTEM ERRORS |                                |  |
| 0600                     | I/O board                      | Faulty bit(s) in printer internal register                       |
| 0601                     | I/O board                      | Incorrect status received when trying to transmit characters     |
| 0602                     | I/O board                      | Incorrect status received when trying to receive characters      |
| 0603                     | I/O board                      | No printer interrupt or incorrect interrupt status received      |
| 0604                     | I/O board                      | Parity test, data transmitted does not equal data received       |
| 0605                     | I/O board                      | Parity test, during a transmit an error condition occurred       |
| 0606                     | I/O board                      | Inability to loop back any signals off board (no loop back plug) |
| 0607                     | I/O board                      | Incorrect status received during transmit or receive             |
| 0608                     | I/O board                      | Baud rate test, timeout – character transfer never completed     |
| 0609                     | I/O board                      | Baud rate test, timing of the current baud rate was out of spec  |
| 0610                     | I/O board                      | Baud rate test, data transmitted does not equal data received    |
| 0611                     | I/O board                      | Bad status received from modem status register                   |
| 0612                     | I/O board <sup>5</sup>         | Some signal(s) unable to be looped back off board                |
| 0613                     | I/O board                      | Unable to clear pending characters or interrupts                 |

<sup>5</sup>Correct the problem as follows.

1. Reseat the printer loopback connector.
2. If the error number is displayed again, replace the loopback connector.
3. If that does not solve the problem, replace the I/O board.



**Table C-2 Service Diagnostics Error Numbers (cont.)**

| <b>Error Number</b>                       | <b>FRU to Check or Replace</b> | <b>Description</b>  |
|---|--------------------------------|---|
| <b>MOUSE SUBSYSTEM ERRORS<sup>6</sup></b> |                                |   |
| 0700                                      | CPU board or connector         | Unable to verify loopback plug (use new diagnostic)                   |
| 0701                                      | CPU board                      | Mouse UART internal register error                                    |
| 0702                                      | CPU board                      | No mouse UART interrupt occurred                                      |
| 0703                                      | CPU board                      | Mouse UART external receive/transmit error, character corrupted       |
| 0704                                      | CPU board                      | Master interrupt controller error                                     |
| 0705                                      | CPU board                      | Slave interrupt controller error                                      |
| 0706                                      | CPU board                      | Mouse UART external loopback status error                             |
| 0707                                      | CPU board                      | Mouse UART external receive/transmit error, character corrupted       |
| 0708                                      | CPU board                      | Mouse UART external loopback timing out of range (use new diagnostic) |
| 0709                                      | CPU board                      | Mouse UART internal loopback status error                             |
| 0710                                      | CPU board                      | Mouse UART internal receive/transmit error, character corrupted       |
| 0711                                      | CPU board                      | Mouse UART external loopback timing out of range                      |
| 0712                                      | Mouse                          | Mouse does not respond to self-test command                           |
| 0713                                      | Mouse                          | Invalid self-test report format                                       |
| 0714                                      | Mouse                          | Self-test detected RAM/ROM error                                      |
| 0715                                      | Mouse                          | Self-test detected right button error                                 |
| 0716                                      | Mouse                          | Self-test detected middle button error                                |
| 0717                                      | Mouse                          | Self-test detected left button error                                  |
| 0718                                      | Mouse                          | Self-test and format revisions do not agree                           |
| 0719                                      | Mouse                          | Mouse does not respond to vendor reserved command                     |

<sup>6</sup>Correct the problem as follows

1. Check the mouse cable connection.
2. Check with new version of diagnostic diskette.
3. If the error occurs again, replace the FRU.

**Table C-2 Service Diagnostics Error Numbers (cont.)**

| <b>Error Number</b>                       | <b>FRU to Check or Replace</b> | <b>Description</b>  |
|---|--------------------------------|---|
| <b>MOUSE SUBSYSTEM ERRORS<sup>6</sup></b> |                                |   |
| 0720                                      | Mouse                          | Mouse is not in Digital reporting format                                |
| 0721                                      | Mouse                          | Reported resolution is not 200 dots per inch                            |
| 0722                                      | Mouse                          | Mouse does not communicate using half-duplex protocol                   |
| 0723                                      | Mouse                          | Mouse does not respond to prompt command                                |
| 0724                                      | Mouse                          | Invalid prompt report format  |
| 0725                                      | Mouse                          | Cannot set incremental stream reporting mode                            |
| 0726                                      | Mouse                          | Cannot set prompt reporting mode  |
| 0727                                      | Mouse                          | Mouse does not ignore received parity or most significant bit           |
| 0728                                      | Mouse                          | Received response to invalid command                                    |
| 0729                                      | Mouse                          | Mouse changed reporting mode via invalid command                        |
| 0730                                      | Mouse                          | Mouse reported position change via invalid command                      |
| 0731                                      | Mouse                          | Right button generated no report  |
| 0732                                      | Mouse                          | Middle button generated no report                                       |
| 0733                                      | Mouse                          | Left button generated no report   |
| 0734                                      | Mouse                          | No mouse position report generated in incremental stream reporting mode |
| 0735                                      | Mouse                          | Mouse position report generated in prompt mode                          |
| 0736                                      | Mouse                          | Incremental stream reporting rate out of range                          |
| 0737                                      | Mouse                          | Mouse transmits more data than specified                                |
| 0738                                      | CPU board                      | UART status error   |
| 0739                                      | Mouse                          | Counters did not change   |
| 0740                                      | Mouse                          | Not all boxes changed   |

<sup>6</sup>Correct the problem as follows

1. Check the mouse cable connection.
2. Check with new version of diagnostic diskette.
3. If the error occurs again, replace the FRU.



**Table C-2 Service Diagnostics Error Numbers (cont.)**

| <b>Error Number</b>                 | <b>FRU to Check or Replace</b> | <b>Description</b>                                      |
|-------------------------------------|--------------------------------|---|
| <b>EVENT TIMER SUBSYSTEM ERRORS</b> |                                |   |
| 0800                                | CPU board                      | CMOS address lines error                                |
| 0801                                | CPU board                      | CMOS RAM error  |
| 0802                                | CPU board                      | CMOS RAM unable to retain its data                      |
| 0803                                | CPU board                      | Event timer not counting seconds                        |
| 0804                                | CPU board                      | Update cycle timing failed (also, see error 803)        |
| 0805                                | CPU board                      | Unable to stop counters via set bit                     |
| 0806                                | CPU board                      | Counter operations failed                               |
| 0807                                | CPU board                      | Update in progress cycle was too long                   |
| 0808                                | CPU board                      | Periodic interrupt timing test failed                   |
| <b>LAN SUBSYSTEM ERRORS</b>         |                                |   |
| 0900                                | I/O board                      | Lance controller failure                                |
| 0901                                | I/O board                      | Interrupt failure, LANCE tried to generate an interrupt |
| 0902                                | I/O board                      | Open or shorted data lines                              |
| 0903                                | I/O board                      | LANCE collision logic failure                           |
| 0904                                | I/O board                      | LANCE transmit error                                    |
| 0905                                | I/O board                      | LANCE receive error                                     |
| 0906                                | I/O board                      | Reserved (use new version of diagnostic)                |
| 0907                                | I/O board <sup>7</sup>         | LANCE external loopback failure                         |
| 0908                                | I/O board                      | Reserved  |
| 0909                                | I/O board                      | LANCE CRC logic failure                                 |
| 0910                                | I/O board                      | Loss of carrier signal during transmission              |
| 0911                                | I/O board                      | Loss of carrier signal, check cable connection          |
| 0912                                | I/O board                      | LANCE memory access error                               |
| 0913                                | I/O board                      | LANCE packet data error                                 |
| 0914                                | I/O board                      | LANCE error detection logic failure                     |
| 0915                                | I/O board                      | Transmission timeout                                    |
| 0916                                | I/O board                      | No interrupt generated by the LANCE                     |
| 0917                                | -                              | Attach the loopback plug                                |
| 0918                                | I/O board <sup>7</sup>         | Loopback plug not connected                             |
| 0919                                | I/O board                      | LANCE initialization failure                            |
| 0920                                | I/O board                      | Logical Address filter logic failure                    |

<sup>7</sup>Correct the problem as follows.

1. Reseat the network loopback connector.
2. If the number is displayed again, replace loopback connector.
3. If that does not solve the problem, replace the I/O board.

**Table C-2 Service Diagnostics Error Numbers (cont.)**

| <b>Error Number</b>           | <b>FRU to Check or Replace</b> | <b>Description</b>   |
|-------------------------------|--------------------------------|--|
| <b>80287 SUBSYSTEM ERRORS</b> |                                |  |
| 1000                          | 80287 <sup>8</sup>             | 80287 bad or not detected, skipping all 80287 tests          |
| 1001                          | 80287                          | Unexpected hot interrupt detected                            |
| 1002                          | 80287                          | Divide exception mask not functioning                        |
| 1003                          | 80287                          | Exception status incorrect                                   |
| 1004                          | 80287                          | Memory access failure or data incorrect                      |
| 1005                          | 80287                          | Internal stack pointer failure                               |
| 1006                          | 80287                          | Unexpected interrupt on 80287 interrupt request line (IRQ13) |
| 1007                          | CPU                            | Slave interrupt controller error                             |
| 1008                          | 80287                          | Internal stack registers not unique                          |
| 1009                          | 80287                          | Internal stack register failure                              |
| 1010                          | 80287                          | Environment register failure                                 |
| 1011                          | 80287                          | Exception mask failure                                       |
| 1012                          | 80287                          | Exception did not generate interrupt                         |
| 1013                          | 80287                          | Status register failure                                      |
| 1014                          | 80287                          | Condition codes incorrect                                    |
| 1015                          | 80287                          | Busy bit not responding correctly                            |
| 1016                          | 80287                          | Exception pointers not generated correctly                   |
| 1017                          | 80287                          | Data type failure  |
| 1018                          | 80287                          | Internal constants incorrect                                 |
| 1019                          | 80287                          | Internal tag word incorrect                                  |
| 1020                          | 80287                          | Transcendental instruction failure                           |
| 1021                          | 80287                          | Arithmetic instruction failure                               |
| 1022                          | 80287                          | Control instruction failure                                  |

<sup>8</sup> Correct the problem as follows.

1. Make sure the 80287 is installed correctly.
2. If a number is displayed again, replace the 80287.
3. If the 80287 test fails again, replace the CPU board.



**Table C-2 Service Diagnostics Error Numbers (cont.)**

| <b>Error Number</b>              | <b>FRU to Check or Replace</b> | <b>Description</b>                             |
|----------------------------------|--------------------------------|--|
| <b>KEYBOARD SUBSYSTEM ERRORS</b> |                                |  |
| 1100                             | Keyboard <sup>9</sup>          | Foreign or no keyboard detected                |
| 1101                             | Keyboard                       | 8042 status error, did not respond as expected |
| 1102                             | Keyboard                       | 8042 to LK250 transmission error               |
| 1103                             | Keyboard                       | LK250 to 8042 transmission error               |
| 1104                             | Keyboard                       | LK250 to 8042 transmission parity error        |
| 1110                             | CPU board                      | 8042 self-test error                           |
| 1120                             | CPU board                      | No keyboard interrupt occurred                 |
| 1121                             | CPU board                      | Master interrupt controller error              |
| 1130                             | Keyboard                       | Illegal command failure                        |
| 1131                             | Keyboard                       | DEC Extended command failure                   |
| 1132                             | Keyboard                       | Compatible command failure                     |
| 1133                             | Keyboard                       | Reserved command failure                       |
| 1160                             | Keyboard                       | Autorepeat rate timing out of range            |
| 1161                             | Keyboard                       | Autorepeat enable failure                      |
| 1162                             | Keyboard                       | Autorepeat disable failure                     |
| 1170                             | Keyboard                       | Autorepeat delay timing out of range           |
| 1171                             | Keyboard                       | Autorepeat enable failure                      |
| 1180                             | Keyboard                       | Illegal scan code                              |

<sup>9</sup>Correct the problem as follows.

1. Make sure a DIGITAL keyboard is connected to the VAXmate workstation.
2. Make sure the DIGITAL keyboard cable is firmly connected.
3. If the failure occurs again, replace the FRU.

**Table C-2 Service Diagnostics Error Numbers (cont.)**

| <b>Error Number</b>                        | <b>FRU to Check or Replace</b> | <b>Description</b>                                |
|--|--------------------------------|---|
| <b>PRINTER CONFIDENCE SUBSYSTEM ERRORS</b> |                                |   |
| 1200                                       | Printer <sup>10</sup>          | Printer timeout                                   |
| <b>VIDEO ALIGNMENT SUBSYSTEM ERRORS</b>    |                                |   |
| 1300                                       | None <sup>11</sup>             | Foreign video detected; cannot execute test       |
| <b>OPTIONAL MEMORY BOARD ERRORS</b>        |                                |   |
| 1400                                       | Optional memory <sup>12</sup>  | DIGITAL memory option board not detected          |
| 1401                                       | Optional memory                | Option parity generator not working correctly     |
| 1402                                       | Optional memory                | Option memory location does not generate parity   |
| 1403                                       | Optional memory                | Option memory error during moving inversions test |
| 1404                                       | Optional memory                | Protected memory exception interrupt occurred     |
| 1405                                       | Optional memory                | Unexpected nonmaskable interrupt (NMI) occurred   |
| 1406                                       | Optional memory                | Option address test failure                       |

<sup>10</sup>Correct the problem by making sure the printer is on-line.

<sup>11</sup>Correct the problem by removing the non-DIGITAL video board.

<sup>12</sup>Correct the problem as follows.

1. Make sure the memory board is seated correctly.
2. If the failure occurs again, replace the memory board.
3. If the failure occurs once more, replace the I/O board.





Table C-2 Service Diagnostics Error Numbers (cont.)

| Error Number  | FRU to Check or Replace | Description   |
|---|-------------------------|---|
| SYSTEM INTERACTION ERRORS   |                         |   |
| <b>NOTE</b>   |                         |   |
| Since many of the errors in this test are caused by the interaction of one or more hardware subsystems, replacing the designated FRU may not eliminate the problem. Therefore, it is up to the Service Technician to judge what FRU(s) can be causing the problem. The circuitry experiencing the interaction problem is listed here. |                         |   |
| 1500  | CPU board               | Event Timer: update cycles not functioning                        |
| 1501  | CPU board               | Keyboard: does not accept command                                 |
| 1502  | -                       | Reserved  |
| 1503  | CPU board               | Event Timer: update interrupts out of range                       |
| 1504  | CPU board               | Event Timer: not enough alarm interrupts occurred                 |
| 1505  | CPU board               | Event Timer: lost track of time                                   |
| 1506  | CPU board               | Event Timer: undefined interrupt occurred                         |
| 1507  | CPU board               | Mouse: UART received character not equal to transmitted character |
| 1508  | CPU board               | Mouse: UART status error  |
| 1509  | CPU board               | Keyboard: wrong response from keyboard                            |
| 1510  | CPU board               | Interrupt controller: unsolicited interrupt occurred              |
| 1511  | I/O board               | Network: unexpected interrupt occurred                            |
| 1512  | I/O board               | Network: LANCE error bit set                                      |
| 1513  | I/O board               | Comm or printer: cannot clear 8250 pending interrupts             |
| 1514  | I/O board               | Comm or printer: 8250 UART does not transmit                      |
| 1515  | I/O board               | Comm: UART status error   |
| 1516  | I/O board               | Comm: Receiver int, no data available                             |
| 1517  | I/O board               | Comm: Receive data not equal to transmit data                     |
| 1518  | I/O board               | Comm: UART does not transmit                                      |
| 1519  | I/O board               | Comm: UART modem status interrupt                                 |
| 1520  | I/O board               | Serial printer: UART status error                                 |
| 1521  | I/O board               | Serial printer: receiver int, no data available                   |
| 1522  | I/O board               | Serial printer: Receive data not equal to transmit data           |
| 1523  | I/O board               | Serial printer: UART does not transmit                            |
| 1524  | I/O board               | Serial printer: UART modem status interrupt                       |
| 1525  | I/O board               | Diskette could not get started                                    |
| 1526  | Diskette                | Diskette error in diskette interrupt handler                      |
| 1527  | Diskette                | Diskette drive did not recalibrate correctly                      |
| 1528  | Diskette                | Diskette drive did not recalibrate to track 0                     |
| 1529  | I/O board               | Diskette controller did not sense track 0 bit                     |

**Table C-2 Service Diagnostics Error Numbers (cont.) (cont.)**

| <b>Error Number</b> | <b>FRU to Check or Replace</b> | <b>Description</b>   |
|---------------------|--------------------------------|--|
| 1530                | Diskette                       | Diskette drive seek failed   |
| 1531                | I/O board                      | Diskette could not detect results  |
| 1532                | Diskette                       | Diskette track write returned incorrect status                             |
| 1533                | Diskette                       | Diskette track read returned incorrect status                              |
| 1534                | Diskette                       | Diskette data read does not equal data written to Diskette                 |
| 1536                | 80287                          | 80287: unexpected 80287 interrupt detected on IRQ13 line                   |
| 1537                | CPU board                      | Interrupt controller: slave interrupt controller error                     |
| 1538                | 80287                          | 80287: Internal constants incorrect  |
| 1539                | 80287                          | 80287: Internal tag word incorrect   |
| 1540                | I/O board                      | Network: Receive data not equal to transmit data                           |
| 1541                | –                              | Reserved   |
| 1542                | 80287                          | 80287: control instruction failure   |
| 1543                | Hard disk                      | Hard disk: error formatting the diagnostic cylinder or drive not formatted |
| 1544                | Hard disk                      | Hard disk: cannot find a good sector on the diagnostic cylinder            |
| 1545                | Disk controller                | Hard disk controller: error processing write command                       |
| 1546                | Disk controller                | Hard disk controller: status error from controller                         |
| 1547                | Disk controller                | Hard disk controller: error processing read command                        |
| 1548                | Hard disk                      | Hard disk: error comparing data read to data written                       |
| 1549                | Modem                          | Modem: error transmitting first character                                  |
| 1550                | Modem                          | Modem: line status register not functioning correctly                      |
| 1551                | Modem                          | Modem: actual data not equal to expected data                              |
| 1552                | Modem                          | Modem intermediate results out of range                                    |
| 1553                | 80287                          | 80287 intermediate results out of range                                    |
| 1554                | Hard disk                      | Hard disk intermediate results out of range                                |
| 1555                | –                              | CPU intermediate results out of range                                      |
| 1556                | CPU board                      | Event timer intermediate results out of range                              |
| 1557                | CPU board                      | Mouse intermediate results out of range                                    |
| 1558                | keyboard                       | Keyboard intermediate results out of range                                 |
| 1559                | I/O board                      | Comm intermediate results out of range                                     |
| 1560                | I/O board                      | Printer intermediate results out of range                                  |
| 1561                | I/O board                      | Diskette intermediate results out of range                                 |
| 1562                | I/O board                      | Network intermediate results out of range                                  |



**Table C-2 Service Diagnostics Error Numbers (cont.)**

| <b>Error Number</b>               | <b>FRU to Check or Replace</b> | <b>Description</b>   |
|-----------------------------------|--------------------------------|--|
| <b>HARD DISK SUBSYSTEM ERRORS</b> |                                |  |
| 1600                              | Disk controller <sup>13</sup>  | Not present  |
| 1601                              | Disk controller <sup>13</sup>  | Faulty bit(s) in controller register                       |
| 1602                              | Disk controller <sup>13</sup>  | Controller not ready when attempting to send command       |
| 1603                              | Disk controller <sup>13</sup>  | No HARD DISK interrupt received                            |
| 1604                              | Disk controller <sup>13</sup>  | Failed internal diagnostics                                |
| 1605                              | Disk controller <sup>13</sup>  | Failed reset – busy bit set                                |
| 1606                              | Disk drive <sup>14</sup>       | Not present/failed to become ready                         |
| 1607                              | Disk drive <sup>14</sup>       | Address marks not found                                    |
| 1608                              | Disk drive                     | Seek operation failed                                      |
| 1609                              | Disk controller <sup>13</sup>  | Controller misinterpreted the command                      |
| 1610                              | Disk controller <sup>13</sup>  | An undefined error has occurred                            |
| 1611                              | Disk drive <sup>16</sup>       | Sector not found error                                     |
| 1612                              | Disk<br>drive/controller       | ECC error  |
| 1613                              | Disk<br>drive/controller       | Bad block detected   |
| 1614                              | Disk controller <sup>13</sup>  | Error bit not set in error register                        |
| 1615                              | Disk drive <sup>16</sup>       | Write fault bit was asserted                               |
| 1616                              | Disk drive <sup>16</sup>       | Drive failed to become ready                               |
| 1617                              | Disk<br>drive/controller       | ECC corrected bit was asserted                             |
| 1618                              | Disk<br>drive/controller       | Time out, remained busy during test controller             |
| 1619                              | Disk<br>drive/controller       | Failed to receive an interrupt                             |
| 1620                              | Disk controller <sup>13</sup>  | Controller never requested the data transfer               |
| 1621                              | Disk controller <sup>13</sup>  | Request for data bit failed to go inactive                 |
| 1622                              | Disk drive                     | Encountered a bad boot cylinder                            |
| 1623                              | Disk drive <sup>15</sup>       | Too many bad sectors on one head                           |
| 1624                              | Disk drive                     | Too many bad sectors on the disk                           |
| 1625                              | Disk drive <sup>15</sup>       | Too many bad sectors during format of diagnostic cylinder  |
| 1626                              | Disk controller <sup>15</sup>  | No error reported during read/write test had data mismatch |
| 1627                              | Disk<br>drive/controller       | Error finding sector to do the read/write test             |



<sup>13</sup>Correct the problem as follows.

1. Make sure the expansion box is connected correctly.
2. Make sure the hard disk controller board is installed correctly and is firmly seated.
3. If the error occurs again, replace the controller board.

<sup>14</sup>Correct the problem as follows.

1. Make sure the cable from the controller to the hard disk is firmly plugged in.
2. Make sure the expansion box is connected correctly.
3. Make sure the hard disk controller board is installed correctly and is firmly seated.
4. If the error occurs again, replace the cables.
5. If the error occurs again, replace the controller board.

<sup>15</sup>Correct the problem as follows.

1. Have the customer back up the data on the disk.
2. Have the customer format the disk.
3. Run the test again.
4. If the same number is displayed, replace the hard disk.

<sup>16</sup>Correct the problem as follows.

1. Follow steps 1 through 5 of Corrective Action 14, above.
2. Follow steps 1 through 4 of Corrective Action 15, above.



Table C-2 Service Diagnostics Error Numbers (cont.)

| Error Number                  | FRU to Check or Replace       | Description   |
|-------------------------------|-------------------------------|---|
| 1628                          | Disk cable <sup>16</sup>      | Error on data compare for the read/write test                   |
| 1629                          | Disk drive                    | Index pulse never toggled                                       |
| 1630                          | Disk drive                    | Drive is out of spec for rotational speed                       |
| 1631                          | —                             | Reserved  |
| 1632                          | Disk controller <sup>13</sup> | Failed to report the correct error                              |
| 1633                          | Disk controller <sup>13</sup> | Failed reset — busy bit not set                                 |
| 1634                          | Disk controller <sup>13</sup> | Status register 3F6 not equal to 1F7                            |
| 1635                          | Disk controller <sup>13</sup> | Digital input register faulty (also, see error 1633)            |
| 1636                          | Disk drive <sup>16</sup>      | Too many soft sectors on one head                               |
| 1637                          | Hard disk                     | Drive parameters invalid – disk not formatted                   |
| 1650                          | Disk drive                    | Soft error, read error (corrected by retry) when verifying disk |
| 1651                          | Disk drive                    | Soft error, FCT not found or corrupted                          |
| <b>MODEM SUBSYSTEM ERRORS</b> |                               |   |
| 1700                          | Modem board <sup>17</sup>     | Modem not present   |
| 1701                          | Modem board <sup>17</sup>     | 8250 UART register failure                                      |
| 1702                          | Modem board <sup>17</sup>     | Modem interrupt IRQ3 test failed                                |
| 1703                          | Modem board                   | Modem parity test failed  |
| 1704                          | Modem board                   | Modem baud rate test failed                                     |
| 1705                          | Modem board                   | Hayes command mode test failed                                  |
| 1706                          | Modem board                   | Hayes mode test commands failed                                 |
| 1707                          | Modem board                   | Modem firmware ROM checksum failed                              |
| 1708                          | Modem board                   | Internal loop back tests failed                                 |
| 1709                          | Modem board <sup>18</sup>     | Remote loop back tests failed                                   |
| 1710                          | Modem board <sup>18</sup>     | Dial up to remote modem failed                                  |
| 1711                          | Remote modem                  | Command to remote modem failed                                  |
| 1712                          | Modem board                   | Forced error test failed  |
| 1713                          | Modem board                   | Escape command failed   |
| 1714                          | Modem board                   | On-hook command failed  |
| <b>PARK DRIVE ERRORS</b>      |                               |   |
| 1800                          | Diskette 0 <sup>19</sup>      | Unable to park diskette drive 0                                 |
| 1801                          | Diskette 1 <sup>19</sup>      | Unable to park diskette drive 1                                 |
| 1802                          | Hard disk 0 <sup>20</sup>     | Unable to park hard disk drive 0                                |
| 1803                          | Hard disk 1 <sup>20</sup>     | Unable to park hard disk drive 1                                |



<sup>13</sup>Correct the problem as follows.

1. Make sure the expansion box is connected correctly.
2. Make sure the hard disk controller board is installed correctly and is firmly seated.
3. If the error occurs again, replace the controller board.

<sup>16</sup>Correct the problem as follows.

1. Follow steps 1 through 5 of Corrective Action 14, above.
2. Follow steps 1 through 4 of Corrective Action 15, above.

<sup>17</sup>Correct the problem as follows.

1. Make sure the modem board is installed correctly and firmly plugged in.
2. If the number is displayed again, replace the modem board.
3. If the failure still occurs, replace the I/O board.

<sup>18</sup>Correct the problem as follows.

1. Make sure that the phone line is operational, there is a dial tone, and the number is correct.
2. Check the functionality of the local modem by dialing into another VAXmate that also has a modem. The remote modem must be operational and set to 1200 baud and autoanswer. If this is unsuccessful, replace the local modem.

<sup>19</sup>Correct the problem by running the diskette drive test.

<sup>20</sup>Correct the problem by running the hard disk test.

**Table C-2 Service Diagnostics Error Numbers (cont.)**

| <b>Error Number</b>  | <b>FRU to Check or Replace</b> | <b>Description</b>                                     |
|--|--------------------------------|--|
| <b>NETWORK INTERACTION ERRORS</b>  |                                |  |
| <b>NOTE</b>  |                                |  |
| The following FRUs are actually referring to the I/O board in either the transmit VAXmate or the echo VAXmate. |                                |  |
| 1900   | —                              | Reserved   |
| 1901   | —                              | Reserved   |
| 1902   | —                              | Reserved   |
| 1903   | —                              | Reserved   |
| 1904   | —                              | Reserved   |
| 1905   | —                              | Reserved   |
| 1906   | —                              | Reserved   |
| 1907   | Xmit/echo                      | Transmit ring failure                                  |
| 1908   | —                              | Reserved   |
| 1909   | —                              | Reserved   |
| 1910   | —                              | Reserved   |
| 1911   | —                              | Reserved   |
| 1912   | Xmit/echo                      | LANCE packet data error                                |
| 1913   | —                              | Reserved   |
| 1914   | Xmit/echo                      | Transmission timeout                                   |
| 1915   | —                              | Reserved   |
| 1916   | Xmit/echo                      | LANCE initialization failure                           |
| 1917   | Xmit/echo                      | Logical address filter logic failure                   |
| 1920   | Xmit/echo                      | Framing error on received packet                       |
| 1921   | Xmit/echo                      | Overflow error during packet reception                 |
| 1922   | Xmit/echo                      | CRC error on received packet                           |
| 1923   | Xmit/echo                      | Buffer error during packet reception                   |
| 1924   | Xmit/echo                      | Byte count error on received packet                    |
| 1930   | Xmit/echo                      | Buffer error during transmission                       |
| 1931   | Xmit/echo                      | Underflow error, transmitting packet                   |
| 1932   | Xmit/echo                      | Late collision encountered during packet transmission  |
| 1933   | Xmit/echo                      | Loss of carrier during packet transmission             |
| 1934   | Xmit/echo                      | Retry flag set during packet transmission              |
| 1935   | Xmit/echo                      | Fatal error, transmitter babbling                      |
| 1936   | Xmit/echo                      | Fatal collision error                                  |
| 1937   | Xmit/echo                      | Fatal error, miss bit set                              |
| 1938   | Xmit/echo                      | Fatal error, memory error bit set                      |
| 1939   | Echo                           | Echo-node timeout, no response received from echo node |

**Table C-3 Install New Diagnostics Error Messages**

| <b>Error Message</b>                      | <b>Action</b>   |
|---|---|
| THE DIAGNOSTIC DISK HAS NOT BEEN REMOVED  | Remove the diagnostic disk from the drive. Remove the write-protect tab from the diagnostic disk. Insert the new disk into the same drive and close the drive door.   |
| DRIVE NOT READY                           | Make sure the disk is inserted correctly. Insert the correct disk and close the drive door.   |
| BAD I/O BOARD                             | Run the diskette test by selecting it from the Individual test mode menu.   |
| FILE NOT FOUND                            | Make sure to use the correct disk and make sure it is not physically damaged.   |
| BAD DISK                                  | Remove and reinsert the disk. Check the disk for any physical damage.   |
| DISK FULL                                 | <p>The test is unable to install the desired test. Make sure the diagnostic disk contains only the diagnostic test and was not used as a general working disk.</p> <p>Make sure that the Service Diagnostic disk was inserted. If it was, there is no more space on the disk for tests to be installed.</p> |
| WRITE PROTECT TAB IS STILL ON             | Remove the Service Diagnostic from the drive, then remove the write-protect tab from the disk. Replace the disk and continue with the procedure.  |
| THE DIAGNOSTIC DISK HAS NOT BEEN REPLACED | Remove the new disk from the drive. Insert the Service Diagnostic disk in the drive (make sure to remove the write-protect tab first). Then, close the drive door.  |





**Table C-3 Install New Diagnostics Error Messages (cont.)**

---

| <b>Error Message</b>            | <b>Action</b>   |
|---------------------------------|---|
| TOO MANY TEST FILES ON THE DISK | Make sure to use the correct disk. There must be no more than two test files on the new disk. |
| TEST VALUE OUT OF RANGE         | The maximum test number is 26.  |
| TEST FILE NAMES DO NOT MATCH    | Test and message files do not have the same test number. Make sure to use the correct disk.   |

---

**Table C-4 System Error Messages**

---

**Messages**

---

The following error messages can be displayed while you are running the Service Diagnostics. These are MS-DOS operating system messages. Try to correct the error by resetting the system by typing **Ctrl/Alt/Del** at the same time, and starting the test again. If the error message is displayed again, get a new Service Diagnostics diskette.

|               |   |
|---------------|---|
| SYSTEM ERROR: | INVALID FUNCTION REQUESTED              |
| SYSTEM ERROR: | TEST NOT FOUND ON DISKETTE              |
| SYSTEM ERROR: | WRONG FUNCTION CALL MADE                |
| SYSTEM ERROR: | ARENA TRASHED                           |
| SYSTEM ERROR: | INSUFFICIENT MEMORY                     |
| SYSTEM ERROR: | TEST CANNOT BE LOADED FROM THE DISKETTE |
| SYSTEM ERROR: | TEST WILL NOT WORK CORRECTLY            |

---

# ***Appendix D*** ***VAXmate CPU*** ***Block Diagram***

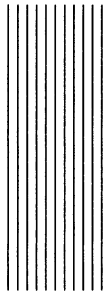

Figure D-1 shows a block diagram of the VAXmate CPU board. If you need more technical information, refer to the *VAXmate Technical Description Manual*.



*VAXmate CPU Block Diagram*



# *Index*

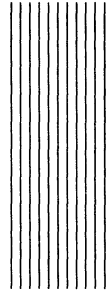

80287, 1-9, 1-10, 2-2, 5-40  
  installation, 5-16  
  replacement, 5-16  
  special option label, 5-17  
  test, B-8

## **A**

Activity indicator, 2-42  
Adapter (DESTA), 3-4  
Adding a VAXmate workstation, 3-13,  
  3-14  
Adjustments, 1-4, 4-1  
  centering, 4-9  
  cutoff, 4-6  
  focus, 4-13  
  height  
    250 line mode, 4-13  
    400 line mode, 4-8  
  horizontal hold, 4-5  
  monitor, 4-2  
  rotation, 4-11  
  video compensation, 4-12  
  width, 4-7  
Alignment patterns, 4-1  
Anode, 5-25  
  discharge, 4-4, 5-21  
  discharge tool, I-3  
Applications, 1-1  
Architecture, 1-1

## **B**

BA500 (expansion box), 2-27  
Back door installation, 5-10  
Back door removal, 5-8  
Backplane, 5-67  
Barrel connector, 3-4, 3-7

Base plate, 5-62  
Baseband, 3-1  
Battery, 1-4, 5-3, 5-74, A-3  
  replacement, 5-74  
Bezel  
  centering, 4-9  
  CRT, 5-26  
  I/O board, 5-46  
  part number, A-2  
  plastic dress on CPU, 5-37, 5-38  
BIOS, B-3  
Block diagram  
  CPU board, D-1  
  I/O-Video board, 1-7  
  VAXmate workstation, 1-5  
Blown fuse, 2-18, 2-20  
BNC, 1-11, 3-4, 3-9, 3-11  
Board, 1-6  
  CPU, 1-8, 2-1, 2-10, 5-27, 5-32  
    components, 5-41  
    removal, 5-37  
  hard disk drive controller, 1-9, 5-54  
  I/O, 1-6, 2-1, 4-2, 5-34, 5-40  
    removal, 5-46  
  locations, 5-12  
  memory option, 1-9  
  modem, 1-10, 2-22  
  monitor, 4-2, 5-32, 5-37  
  power regulator, 2-21, 5-72, 5-73  
  power supply, 1-8, 2-22, 5-34, 5-40  
  power supply replacement, 5-50  
  read/write, 5-57  
Booting, 2-6, 2-16, 2-18, 2-24  
Bridge replacement, 5-70, 5-71  
Brightness, 4-1, 4-2



## C

### Cable

- 15-pin, 3-12
- battery, 5-64, 5-67, 5-74
- communications, 2-40
- Ethernet, 1-11
- ground lug, 5-32
- lengths, 3-7
- modem, 3-5
- mouse, 2-40
- power, 5-34
- printer, 2-40
- ribbon, 5-23, 5-34, 5-36
- speaker, 5-33, 5-37
- TV network, 3-5
- ThinWire, 1-9, 1-11, 3-3
  - section, 3-3
  - segment, 3-3
- unplugging, 5-4

### Card cage, 5-67

### CATV, 3-5

### Centering, 4-9

### Charnel, 5-30

### Communications

- port loopback, B-2
- test, B-2

### Components, 1-3

- ThinWire, 3-1

### Computer, 1-1

- MicroVAX II, 1-1, 3-11
- VAX, 1-1

### Configuration

- network testing, B-6

### Configuration list, 2-2, 2-24, 2-25

- main diagnostic menu, 2-29, 2-30
- sample, 2-24

### Connecting loopback connectors, 2-41, 3-6

### Connector, 1-3, 2-41, 3-6

- 4-pin, 5-24, 5-32
- 9-wire filament, 5-26, 5-32
- anode, 5-32
- assembling network loopback, 2-37, 2-39
- barrel, 3-4, 3-7
- BNC, 1-11, 3-11, 3-4, 3-9
- loopback, 2-37
- network port loopback, 2-37
- read/write board, 5-57, 5-59

### T-connector, 1-3, 2-37, 2-38, 3-4, 3-7

### terminator, 1-3, 2-37, 3-4

### ThinWire loopback, B-6

### Continue on error, 2-35

### Continuous test passes, 2-36

### Contrast, 4-1, 4-2

### Controller, hard disk, 5-65

### Controls

#### brightness, 4-2, 4-6

#### contrast, 4-2, 4-6

#### F, 4-3, 4-13

#### G2, 4-3, 4-6

#### H2, 4-3, 4-13

#### H4, 4-3, 4-8

#### HH, 4-3, 4-5

#### VC, 4-3, 4-12

#### W, 4-3, 4-7

#### yoke centering rings, 4-10

### Country specific components, A-1, A-6

### Cover removal

- system unit, 5-11

### CPU board, 2-1, 2-10, 2-15, 2-17, 2-22, 5-27, 5-32, 5-42

#### block diagram, D-1

#### components, 5-41

#### grounding kit (PC500-UA), 1-8, 5-42, A-1

#### installation, 5-37, 5-42

#### removal, 5-37

### CRT

#### bezel, 5-26

#### filament connector, 5-32

#### handling precautions, 5-25

#### installation, 5-31

#### monitor adjustments, 5-1

#### removal, 5-25, 5-30

#### shield, 5-23, 5-26

#### Tech Tip 20, 5-20, 5-25

#### tilt bar, 5-26

#### yoke, 5-26

### Ctrl/Alt/Del, 2-27, 2-48

### Ctrl/Alt/Home, 2-22

### Ctrl/PF3, 2-33, 2-35, 2-36, B-13

### Cutoff, 4-6

## D

### Data terminal equipment, 3-4

### DELNI, 3-7

### DEMPR, 1-4, 1-11, 3-16, 3-4, 3-7, B-13

- DESTA, 1-4, 1-10, 3-4, 3-11, B-13
- Diagnostic errors, 2-28
- Diagonal cutters, 5-26
- Discharge anode, 5-21
- Disconnecting from network, 2-38, 3-6, 5-3
- Diskette, I-3
  - high and low density, B-3
  - high density, 2-22
  - key, 3-6
  - low density, 2-22
- Diskette drive, 1-8, 2-1, 2-15, 2-22
  - failure, 2-17
  - heat shield, 5-33, 5-42, A-1
  - housing, 5-33, 5-34
  - inserting diskette, 2-23
  - installation, 5-36
  - removal, 5-33
  - test, B-3
- Do not log errors, 2-36, 2-48
- Documentation, I-5
- Drive
  - diskette drive removal, 5-33
  - diskette drive test, B-3
  - diskette, 1-8, 2-1, 2-15, 2-17
  - hard disk removal with fan present, 5-54
  - hard disk removal without fan, 5-52
  - hard disk, 1-9, 2-1, 2-17, B-11
  - recalibrate, B-12
- DTE, 3-4
- E**
- EGA/network conflict, 1-8, 2-10, 5-42
- Electrical description, 1-11
- End of segment, 3-13
- Environmental airspace, 3-3
- Environmental description, 1-11
- Error, I-4
  - continue on, 2-35
  - continuous test passes, 2-36
  - count, 2-32
  - do not log errors, 2-36, 2-48
  - five test passes, 2-36
  - four-digit, 2-34
  - hard, 2-32
  - log errors, 2-35
  - loop on, 2-35
  - Net804, 3-6
  - proceed from, 2-35
  - prompt on, 2-34
  - reporting
    - test option, 2-34
  - ROM diagnostic screen, 2-28, 2-29
  - single test pass, 2-36
  - soft, B-3
- Error log, 2-31, 2-43, 2-47, 2-48, B-3
  - erased, 2-48
  - error messages, 2-49
  - printing, 2-49
- Error log mode, 2-48, 2-49
- Error messages, C-1
  - install diagnostic, C-21
  - system, C-22
- Error number, 2-3, 2-10, 2-15, 2-16, 2-18, 2-25, C-1
  - error 40, 2-15, 2-17, C-2
  - error 43, 2-25, C-3
  - error 60, 2-17, C-3
  - error 83, 2-17, C-3
  - error 87, 2-17, C-3
  - error 99, C-3
  - four-digit, 2-28, 2-32, 2-42, C-4
  - list, C-1
  - ROM diagnostic, C-1
  - service diagnostic, C-4
  - two-digit, 2-16, 2-25, 2-28, C-1
- Ethernet, 1-6, 1-7, 1-9, 3-1, 3-6, B-6
- Ethernet address chip, 5-41, 5-42
- Event timer, 1-5, 1-11, 5-3
  - test, B-1, B-5
- Expansion box, 1-4, 1-5, 1-10, 2-3, 2-26, 3-9, 5-2, A-2
  - backplane, 5-67
  - card cage, 5-64,
  - cover removal, 5-50
  - fan removal, 5-68, 5-69
  - newly installed, 2-25
  - part numbers, A-2
  - pins, 2-21
  - power connector and bridge, 5-70, 5-71
  - separating from system unit, 5-5
- Extended Self-Test, 2-2, 2-5, 2-18, 2-22, 2-25, 3-6, 5-3
  - configuration list, 2-2, 2-24, 2-25
  - how to run, 2-22
  - successful, 2-24
  - unsuccessful, 2-24



## F

- F, 4-3
- Faceplate, 3-5
- Failed, 2-31, 2-43, 2-46
  - unsuccessful, 2-33
  - XXXXXX, 2-44
- Fan replacement, 5-68
- FCC Class A, 1-12
- FDISK, 2-17
- Five test passes, 2-36
- Focus, 4-13
- FORMAT, 2-17
- Four modes, 2-31
- FRU replacement, 5-1
- FRU, I-1, 1-3, 2-2, 2-18, 2-25, A-1
- Fuse, 5-6, A-2
  - blown, 2-18, 2-20
  - keyboard fuse on CPU board, 2-14, 2-17

## G

- G2, 4-3
- Ground
  - lug, 5-27
  - straps, 5-27, 5-42, A-1

## H

- H2, 4-3
- H4, 4-3
- H4005, 3-7
- Hard disk drive, 1-9
  - base plate, 5-56, 5-62
  - cable, 2-21
  - controller, 2-1, 5-65
    - removal, 5-65
  - failure, 2-17
  - FDISK and FORMAT, 2-17
  - formatted, 2-17
  - formatting, 2-26
  - installation, 5-65
  - newly installed, 2-17
  - read/write board, 5-57
  - removal with fan present, 5-54
  - removal without fan present, 5-52
  - test, B-11
- Hard errors, 2-32
- Heat shield, 5-19, 5-33, 5-36, 5-42
- Height adjustment
  - 250 line mode, 4-13
  - 400 line mode, 4-8

- HH, 4-3, 4-5
- Horizontal bar, 2-6, 2-10, 2-16, 2-25
- Horizontal hold, 4-3, 4-5

## I

- I/O-Video board, 2-1, 2-22, 4-2, 5-40
  - block diagram, 1-7
  - installation, 5-49
  - removal, 5-46
  - shield, 5-47
- Individual test, 2-6, 2-25, 2-31, 2-32, 2-44
  - execution screen, 2-45
  - memory, 2-44
  - menu, 2-45
  - selection, 2-45
- Industry-standard, 1-1, 1-12
- Install new diagnostic error messages, C-4
  - the network, 3-6, 3-8
  - update Service Diagnostic, 2-3, 2-31, 2-47
- VAXmate server, 3-9

## J

- Jack, 3-5
- Jumper
  - CPU board, 2-10, 2-15, 2-17, 5-41
  - drive select, 5-60
  - FG on diskette drive, 5-36, 5-37
  - modem, 2-10, 2-26, 5-15
- Junctions, 3-7

## K

- Key diskette, 3-6
- Keyboard, 2-1, 2-17
  - failure, 2-17
  - fuse on CPU board, 2-14, 2-17
  - labels, 1-7
  - replacement, 5-75
  - test, B-8
- Keyclicks, B-9
- Keys
  - arrow, 2-33
  - Ctrl/Alt/Del, 2-27, 2-47
  - Ctrl/Alt/Home, 2-2, 2-22





- Ctrl/PF3, 2-33, 2-35, 2-36
  - Extended Self-Test, 2-23
  - F2 (print log), 2-49
  - PREV SCREEN, 2-49
  - select, 2-45
  - Service Diagnostics, 2-27
- L**
- L-bracket, 5-12
  - LA75 printer, 2-27
  - LAN (Local Area Network), 3-1, 3-9, 3-15
  - LED, 2-1, 2-3, 2-10, 2-25, 2-47
    - CPU board, 2-15
    - diagnosing, 2-11 through 2-14
    - expansion box, 2-19
    - functions, 2-3
    - I/O board, 2-10, 2-15
    - keyboard, 2-17
    - locations, 2-3
    - power, 5-27, 5-32
    - read/write board, 5-57
    - removal and replacement, 5-44
  - Li, 2-24
  - Lithium battery, 1-4, 2-24, A-3
  - LNO3 PLUS printer, 1-10
  - Local area network, see LAN
  - Local network link test, 3-6, B-12
  - Log errors, 2-35
  - Loop, 2-32
  - Loop line controller test, 3-6
  - Loop on error, 2-35
  - Loopback, I-3
    - connector, 2-37
    - connecting to VAXmate, 2-41, 3-6
- M**
- Main diagnostic menu, 2-29, 2-30, 4-1
  - Maintenance Kit, I-1, 2-3, 2-22
  - Map, ThinWire network, 3-16
  - Math coprocessor (80287), 1-9, 1-10, 2-2, 5-41
    - replacement, 5-16
  - Measurements
    - centering, 4-9
    - rotation, 4-11
    - screen height
      - 250 line mode, 4-13
      - 400 line mode, 4-8
    - screen width, 4-7
  - Memory, 2-2
    - dynamic, B-2
    - optional, 1-9, 1-10, 2-2, 5-3
    - protected, 2-2, B-2
    - real, 2-2, B-2
    - test, B-2
  - Memory option replacement, 5-13
  - MicroVAX II computer, 3-4, 3-11
  - MicroVAX II server, 3-11
  - Middle of segment, 3-14
  - MJ, 3-5
  - MMJ, 3-5
  - Mode, 2-31
    - error log, 2-48, 2-49
    - Individual Tests, 2-44
    - new diagnostic installation, 2-47
    - selection, 2-33
    - System Test, 2-33
  - Modem, 2-22, 5-3
    - cable, 3-5
    - failure, 2-26
    - installation, 5-14
    - replacement, 5-14
    - testing, 2-26, B-11
  - Modified modular jack, 3-5
  - Modular jack, 3-5
  - Monitor, I-4, 1-6
    - adjustments, 4-1
    - CRT, 1-6
    - tilt bar, 1-6, 5-26
  - Monitor problems
    - dark screen, 4-2, 4-3
    - edges too bright, 4-3, 4-12
    - focus, 4-3, 4-13
    - height, 4-3, 4-8, 4-13
    - horizontal movement, 4-3, 4-5
    - not centered, 4-3, 4-9
    - retrace lines, 4-3, 4-6
    - slanted, 4-3, 4-11
    - too narrow, 4-3, 4-7
  - Monitor board, 2-22, 4-2, 5-37
    - installation, 5-25
    - removal, 5-20
  - Mouse, 1-9
    - cleaning, 5-75
    - replacement, 5-75
    - test, B-5
  - Multiport repeater, 3-4



**N**

- Network, I-1, 1-1, 2-3, 2-6
  - disconnecting from, 2-38
  - installation, 3-6
    - incorrect, 3-7, 3-8
  - LAN (Local Area Network), 3-1, 3-9, 3-15
  - local link test, B-12
  - loopback connector, 2-37
  - map, 3-16
  - test, 3-6, B-6
  - troubleshooting, 3-1, 3-6
  - worksheet, 3-16
- Network port loopback connector, 2-37, 2-38
  - assembling, 2-37, 2-38
- New diagnostic installation, 2-47
- New disk, 2-47
- Newly installed expansion box, 2-25
- Node, 3-5
- NTU, 3-6

**O**

- Ohmmeter, I-3, B-6
- Operating system, 2-28
- Option, 1-4, 2-25
  - 80287, 1-8, 5-16
  - backplane, 5-67
  - default, 2-34
  - in expansion box, 5-66
  - industry-standard, 1-12
  - memory, 1-8, 2-22, 5-3
  - memory replacement, 5-13
  - memory test, B-9
  - modem, 1-9, 2-10, 2-22, 5-3
  - modem replacement, 5-14
  - non-DIGITAL, 2-2, 2-21
    - video, 2-6
  - replacement, 5-66
  - selection, 2-34
  - slot, 2-21
  - special option installed label, 5-17
  - testing, 2-31
- Overcurrent shutdown, 2-18
- Overheating, 2-18
- Overload, 2-18
- Overvoltage shutdown, 2-18

**P**

- Park all drives, B-12
- Part numbers, I-2, A-1
- Pass definition, 2-32
- Passed, 2-31, 2-43, 2-47
  - successful, 2-33
  - XXXXXX, 2-44
- Patterns
  - grid/circle, 4-12
  - screen of E's, 4-4 through 4-12
    - 250 line mode, 4-13
    - 400 line mode, 4-12
  - video alignment, 4-1, B-9
- PCSA, 1-1
- Pivot cradles, 5-31
- Ports, 3-4
- Power
  - consumption
    - system unit, 1-12
    - expansion box, 1-13
  - failure, 2-18
  - maximum watts, 1-12
  - requirements, 1-10, 2-21
  - shut down, 2-18
  - supply, 2-22
- Power cord latch, 5-7
- Power LED removal, 5-44
- Power regulator board, 2-21
  - replacement, 5-61, 5-72
- Power supply board, 1-7, 5-39
  - replacement, 5-50
- Power-Up Test, 2-1, 2-5, 2-6, 2-18, 3-6, 5-3
  - how to run, 2-6
  - successful, 2-6
  - unsuccessful, 2-10
- Printer, 1-9, 3-11
  - confidence test, B-9
  - LA75, 1-9, 2-27
  - LNO3 PLUS, 1-9
  - port test, B-5
  - Power-Down Sequence, 2-27
  - Power-Up sequence, 2-27
- Printing error log, 2-49
- Proceed from error, 2-35
- Prompt on error, 2-34
- PVC, 3-3

**R**

RCD31/32 controller (see Hard Disk Controller)  
RCD31-EA, -EC (-FA, -FC), 1-13  
RD31, 1-13, A-3 (see also Hard Disk Drive)  
RD32, 1-13, A-3 (see also Hard Disk Drive)  
Read/write board, 5-57  
Recommended spares, A-1  
Removal, 1-4, 5-1  
Replacement procedures, 5-1  
Replacement, 1-4, 5-1  
Retrace lines, 4-6  
ROM diagnostic error screen, 2-28, 2-29  
ROM, 2-1 and 2-2  
ROM-BIOS, 1-1  
Rotation, 4-11  
RX33, 1-8, 1-12 (see also Diskette Drive)

**S**

Sample error log screen, 2-49  
Screen problems (see Monitor Problems)  
Screens  
    individual test execution, 2-45  
    individual test menu, 2-45  
    main diagnostic menu, 2-29, 2-30, 4-1  
    ROM diagnostic error, 2-29  
    sample error log, 2-49  
    system test execution, 2-43  
    system test requirements, 2-37  
    test option menu, 2-34  
Section, 3-3, 3-9  
Segment, 3-3, 3-9, 3-13, 3-14  
Separating expansion box from system unit, 5-5  
Server, 1-1, 3-4, 3-5  
    MicroVAX II installation, 3-11  
    VAXmate installation, 3-9  
Service Diagnostics, 1-3, 2-3, 2-5, 2-25, 2-26, 2-27, 2-29, 2-32, 3-6  
    configuration list, 2-29, 2-30  
    error log, 2-32  
    error reporting, 2-34  
    how to run, 2-27  
    individual test, 2-25, 2-31, 2-32, 2-44  
    modem, 2-26

install diagnostic error messages, C-21  
mode selection, 2-33  
modes, 2-29, 2-30, 2-31  
new diagnostic installation, 2-31  
successful test  
    error log, 2-32  
    XXXXXX, 2-44  
system test, 2-31, 2-32

**Shield**

CRT, 5-23, 5-26  
diskette drive heat shield, 5-19, 5-42  
I/O board, 5-45  
webbed, 5-20

**Short circuit, 2-18, 2-20****Shutdown**

overcurrent, 2-18  
overvoltage, 2-18  
thermal, 2-18

**Single test pass, 2-36****Skid plate, 5-61****Soft errors, B-3****Spares, A-1****Speaker**

cable, 5-37  
keyboard, 2-6, 2-15, 2-16, 2-25  
replacement, 5-18, 5-19  
test, B-5

**Special option label, 5-17****Static electricity, 5-3****Successful test, 2-6, 2-43**

error log, 2-32  
Extended Self-Test, 2-24  
Power-Up, 2-6  
XXXXXX, 2-44

**Symptoms**

CPU and LEDs, 2-10, 2-11  
EGA/network conflict, 1-8, 2-10, 5-42  
error number, C-1  
monitor, 4-3

**System administrator, 3-13, 3-16****System configuration, 2-29, 2-30****System error messages, C-22****System errors, C-1****System halt, 2-15****System interaction test, B-10**



System test, 2-5, 2-31 — 2-33, 3-6  
execution, 2-42  
how to run, 2-33  
requirements, 2-37  
successful, 2-33  
unsuccessful, 2-33  
XXXXXX, 2-44

System unit, 1-3, 5-5  
back door, 5-6, 5-7  
cover removal, 5-11

**T**

T-connector, 2-38, 3-3, 3-7, 3-9  
Tape measure, 1-3, 4-1, 4-7  
Tech Tip 20, 5-20, 5-25  
Teflon, 3-3  
Terminator, 2-37, 3-4, 3-9, B-6  
Test, 2-1  
80287, B-8  
aborting using CTRL/PF3, 2-33, 2-35,  
2-36  
communications, 2-2  
communications port, B-2  
descriptions, 1-4, B-1  
diskette drive, B-3  
event timer, 2-2, B-5  
exceptions, 2-26  
Extended Self-Test, 2-2, 2-5, 2-18,  
2-22, 3-6, 5-3  
hard disk, B-11  
individual, 2-6, 4-1  
installing new, 2-3, 2-47  
keyboard, B-8  
local link (19), 3-6  
loop, 2-32  
loop line controller, 3-6  
loopback, 2-2  
memory, B-2  
modem, 2-26, B-11  
mouse, 2-2, B-5  
network, 3-6, B-6  
option, 2-34  
option memory, B-9  
Power-Up, 2-1, 2-2, 2-5, 2-6, 2-18,  
3-6, 5-3  
printer, 2-2  
printer confidence, B-9  
printer port, B-4  
ROM diagnostic sequence, 2-6 — 2-9

Service Diagnostics, 2-5, 2-27  
speaker, B-4  
status, 2-29, 2-31  
system, 2-5, 3-6  
system interaction, B-10  
updating, 2-3, 2-31, 2-47  
video, B-3

Thermal shutdown, 2-18  
ThinWire, 1-7, 1-9, 3-1  
cable section, 3-3  
cable segment, 3-3  
cabling, 3-3  
components, 3-1  
Ethernet cable, 3-3  
installation, 3-1  
network, 3-9  
troubleshooting, 3-1

Tilt bar, 5-26  
Tilt channel, 5-30  
Transceiver, 3-7  
Troubleshooting, 1-1, 2-1  
network, 2-1, 3-1, 3-6  
VAXmate, 2-5  
Turn off power, 5-4

**U**

UL (Underwriter's Lab), 3-3  
Unplug cables, 5-4  
Unsuccessful test, 2-43  
error log, 2-32  
error number, 2-16  
Extended Self-Test, 2-24  
Power-Up Test, 2-10  
XXXXXX, 2-44  
Updating tests, 2-3, 2-31, 2-47

**V**

VAXmate workstation  
block diagram, 1-5  
components, 1-3  
server installation, 3-9  
VC, 4-3  
Video, 2-1, 2-6, 2-15  
alignment patterns, 4-1, B-9  
compensation, 4-12  
equipment, 3-5  
problems (see Monitor Problems)  
test, B-3  
Voltage, 4-10, 4-11

**W**

W, 4-3  
Webbed shield, 5-20  
Width, 4-7  
Workstation, I-4, 1-1  
Write-protect tab, 2-46

**X**

XXXXXX message, 2-44

**Y**

Yoke, 5-26  
    centering rings, 4-10  
    clamp, 4-11

