

Digital Equipment Corporation
Maynard, Massachusetts

digital

**Maintenance Manual
Volume II**

RK8 Disk System

**RK8 DISK SYSTEM
MAINTENANCE MANUAL
VOLUME II**

Copyright © 1970 by Digital Equipment Corporation

The material in this manual is for information purposes and is subject to change without notice.

The following are trademarks of Digital Equipment Corporation, Maynard, Massachusetts:

DEC	PDP
FLIP CHIP	FOCAL
DIGITAL	COMPUTER LAB

CONTENTS

Figure Number	Description	Drawing Number
RK01 Disk Drive		
Figure II-1	RK01 Basic Format Diagram	D-TD-RK01-X-12
Figure II-2	RK01 Block Diagram	D-BD-RK01-X-13
Figure II-3	RK01 Flow Diagram	D-FD-RK01-X-14
Figure II-4	RK01/RK08 Timing Diagram	D-TD-RK01-X-15
Figure II-5	Format Delays Block Schematic Diagram	D-BS-RK01-X-01
Figure II-6	Cable to RK08 Block Schematic Diagram	D-BS-RK01-X-09
Figure II-7	Track Seek Block Schematic Diagram	D-BS-RK01-X-02
Figure II-8	Disk and Track Address Block Schematic Diagram	D-BS-RK01-X-03
Figure II-9	Compare Track Address Block Schematic Diagram	D-BS-RK01-X-04
Figure II-10	Disk Selection Block Schematic Diagram	D-BS-RK01-X-05
Figure II-11	Disk Cables Block Schematic Diagram	D-BS-RK01-X-06
Figure II-12	+3V Loads Block Schematic Diagram	D-BS-RK01-X-07
Figure II-13	+3V Clamp Block Schematic Diagram	D-BS-RK01-X-08
RK08 Disk Control		
Figure II-14	IOT Decoding Block Schematic Diagram	D-BS-RK08-0-05 Sheet 1 of 2
Figure II-15	IOT Decoding Block Schematic Diagram	D-BS-RK08-0-05 Sheet 2 of 2
Figure II-16	Skip and Break Block Schematic Diagram	D-BS-RK08-0-06
Figure II-17	Maintenance Register Block Schematic Diagram	D-BS-RK08-0-07
Figure II-18	Major Sequencer Register Block Schematic Diagram	D-BS-RK08-0-08
Figure II-19	R/W Command, Find Sector, End transfer Block Schematic Diagram	D-BS-RK08-0-09
Figure II-20	Read Block Schematic Diagram	D-BS-RK08-0-10
Figure II-21	Write Block Schematic Diagram	D-BS-RK08-0-11
Figure II-22	Data Buffer Block Schematic Diagram	D-BS-RK08-0-12
Figure II-23	Data Shift Register Block Schematic Diagram	D-BS-RK08-0-13
Figure II-24	Longitudinal Parity Block Schematic Diagram	D-BS-RK08-0-14 Sheet 1 of 2
Figure II-25	Longitudinal Parity Block Schematic Diagram	D-BS-RK08-0-14 Sheet 2 of 2

CONTENTS (Cont)

Figure Number	Description	Drawing Number
RK08 Disk Control (Cont)		
Figure II-26	Status Register Block Schematic Diagram	D-BS-RK08-0-15
Figure II-27	Sector Addressing Block Schematic Diagram	D-BS-RK08-0-16 Sheet 1 of 2
Figure II-28	Sector Addressing Block Schematic Diagram	D-BS-RK08-0-16 Sheet 2 of 2
Figure II-29	Bit and Block Counter Block Schematic Diagram	D-BS-RK08-0-17
Figure II-30	Word Count (WC) Register Block Schematic Diagram	D-BS-RK08-0-18
Figure II-31	Current Address and EMA Register Block Schematic Diagram	D-BS-RK08-0-19
Figure II-32	AC Input Gating 00-05 Block Schematic Diagram	D-BS-RK08-0-20
Figure II-33	AC Input Gating 06-11 Block Schematic Diagram	D-BS-RK08-0-21
Figure II-34	AC Memory Buffer (MB) Inverters Block Schematic Diagram	D-BS-RK08-0-22
Figure II-35	+3V Clamps Block Schematic Diagram	D-BS-RK08-0-23
Figure II-36	Cable to RK01-X Block Schematic Diagram	D-BS-RK08-0-24
Figure II-37	I/O and Data Break Cables Block Schematic Diagram	D-BS-RK08-0-25
Figure II-38	Indicator Cables Block Schematic Diagram	D-BS-RK08-0-26
Power Supply		
Figure II-39	Type 716 Power Supply Circuit Schematic Diagram	C-CS-716-0-1
Figure II-40	Type 854 Power Control Panel Wiring Diagram	B-CS-854-0-1
Figure II-41	Type 854 Power Control Panel Component Pin Location Diagram	D-UA-854-0-0
Figure II-42	Register Indicator Panel Circuit Schematic Diagram	D-CS-5408458-0-1
Figure II-43	Control Panel Switch Assembly Diagram	E-AD-7006672-0-0
Figure II-44	AC/DC Power Wiring Diagram	E-IC-RK01-0-2

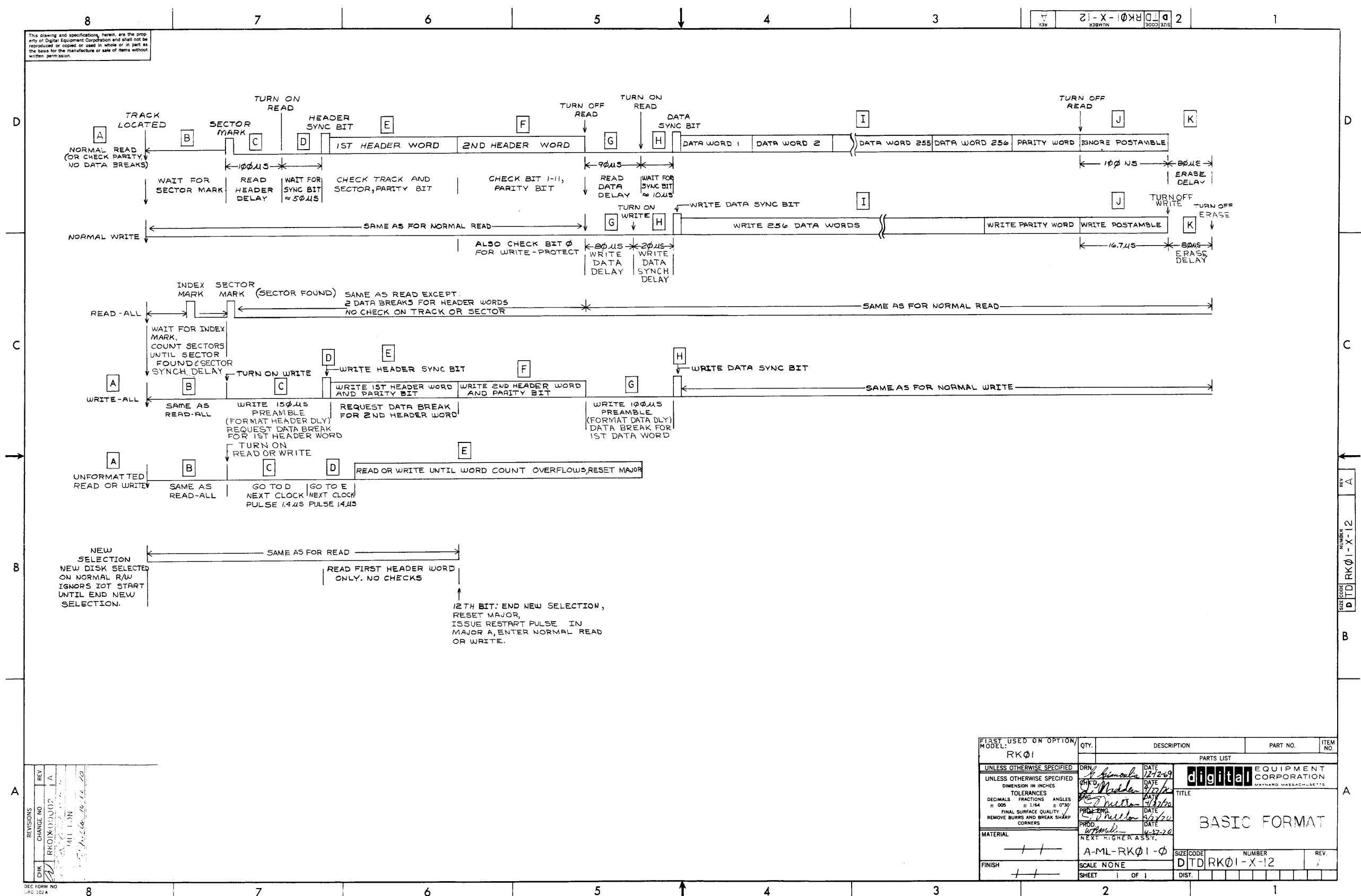

REV	1 A
CHG	RK01-X-12
CHK	MILLIN
DATE	11-16-66
TIME	11:20

FIRST USED ON OPTION/ MODEL:	QTY.	DESCRIPTION	PART NO.	ITEM NO.
RK01				
PARTS LIST				
UNLESS OTHERWISE SPECIFIED	DRN	DATE	digital EQUIPMENT CORPORATION MAYNARD, MASSACHUSETTS	
DIMENSION IN INCHES	CHK'D	DATE	TITLE	
TOLERANCES	BY	DATE	BASIC FORMAT	
DECIMALS FRACTIONS ANGLES	BY	DATE		
± .005 ± 1/64 ± 0°30'	BY	DATE		
FINAL SURFACE QUALITY	PROD	DATE		
REMOVE BURRS AND BREAK SHARP CORNERS	BY	DATE		
MATERIAL	NEXT HIGHER ASSY.			
FINISH	A-ML-RK01-0			
SCALE NONE	SIZE CODE		NUMBER	
SHEET 1 OF 1	D T D		RK01-X-12	
	DIST.		REV.	

Figure II-1 RK01 Basic Format Diagram

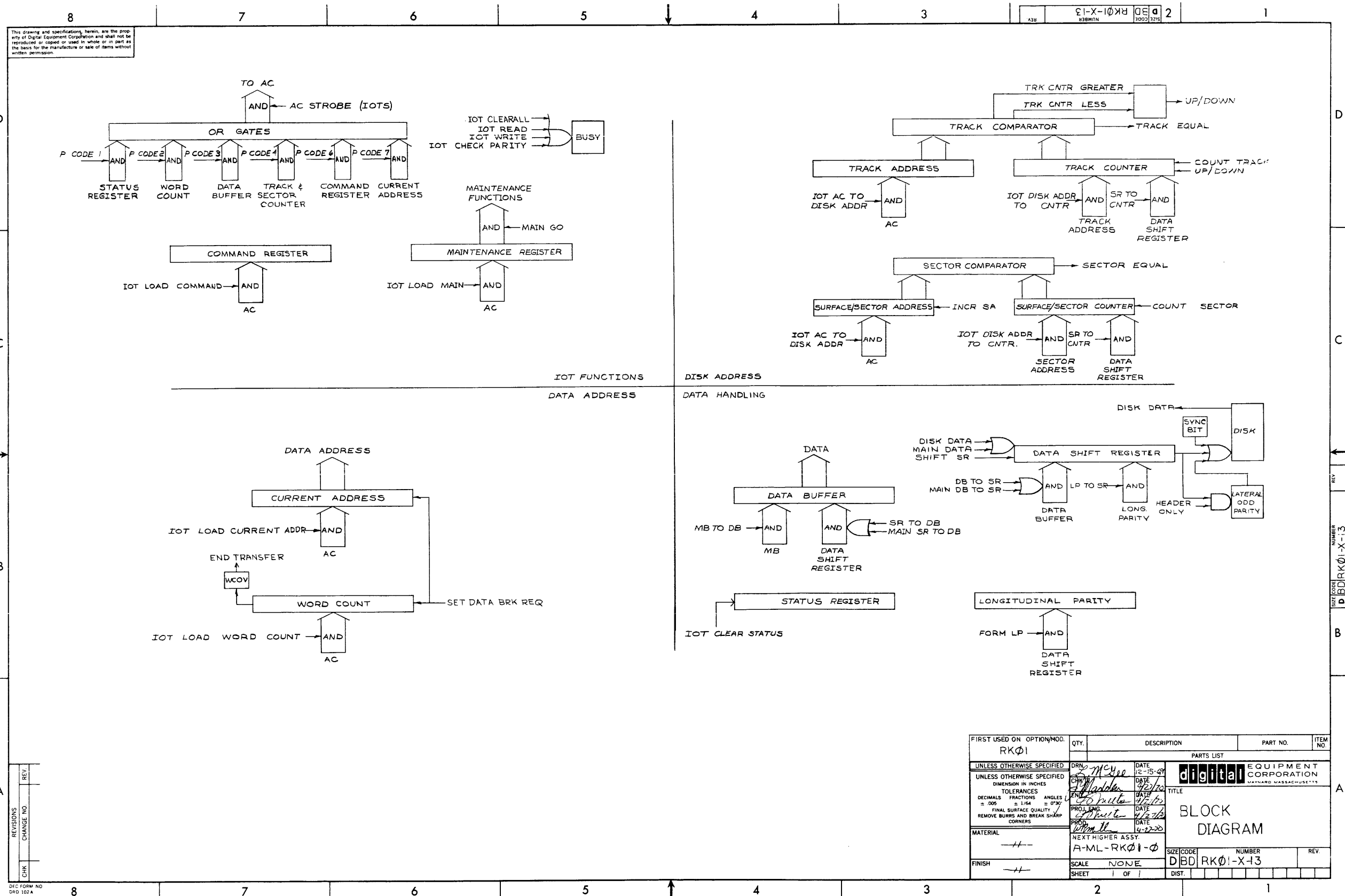

This drawing and specifications, herein, are the property of Digital Equipment Corporation and shall not be reproduced or copied or used in whole or in part as the basis for the manufacture or sale of items without written permission.

FIRST USED ON	OPTION/MOD.	QTY.	DESCRIPTION	PART NO.	ITEM NO.
RK01					
PARTS LIST					
UNLESS OTHERWISE SPECIFIED		DRN. <i>MCY</i>	DATE <i>12-15-67</i>	digital EQUIPMENT CORPORATION MAYNARD, MASSACHUSETTS	
DIMENSION IN INCHES		CHKD. <i>W. H. ...</i>	DATE <i>12/15/67</i>	TITLE	
TOLERANCES		PROJ. ENG. <i>W. H. ...</i>	DATE <i>4/27/68</i>	BLOCK DIAGRAM	
DECIMALS FRACTIONS ANGLES		PROD. <i>W. H. ...</i>	DATE <i>4-27-68</i>	SIZE CODE NUMBER	
± .005 ± 1/64 ± 0°30'		REVISIONS		D B D R K 0 1 - X - 1 3	
FINAL SURFACE QUALITY		REVISIONS		REV.	
REMOVE BURRS AND BREAK SHARP CORNERS		REVISIONS		REV.	
MATERIAL		NEXT HIGHER ASSY.		REV.	
FINISH		SCALE NONE		REV.	
SHEET 1 OF 1		DIST.		REV.	

Figure II-2 RK01 Block Diagram

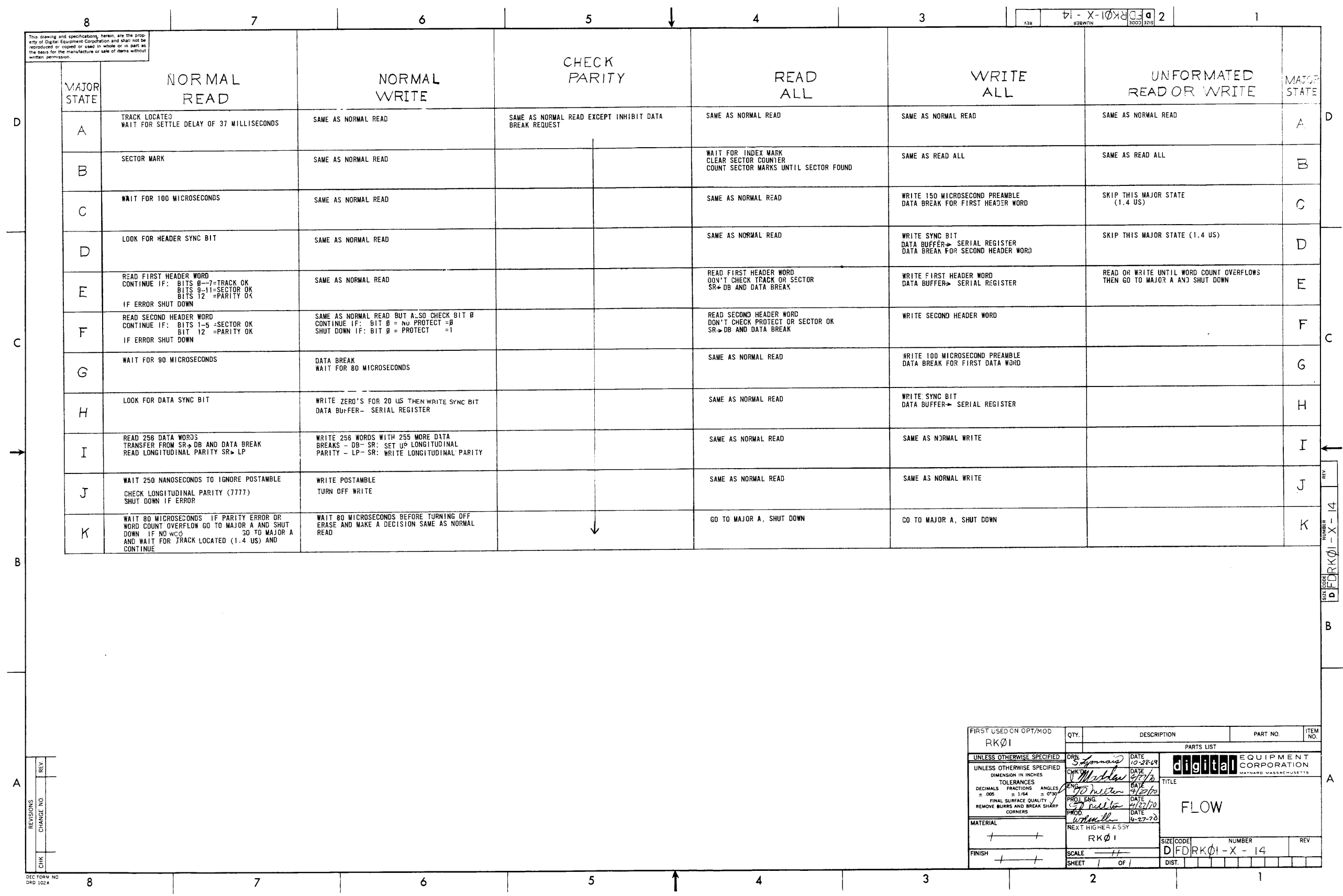

FIRST USED ON OPT/MOD RK01	QTY.	DESCRIPTION	PART NO.	ITEM NO.
PARTS LIST				
UNLESS OTHERWISE SPECIFIED	DRN	DATE	digital EQUIPMENT CORPORATION MAYNARD, MASSACHUSETTS	
DIMENSION IN INCHES	CHKD	DATE	TITLE	
TOLERANCES	ENG	DATE	FLOW	
DECIMALS FRACTIONS ANGLES	PROJ. ENG.	DATE	SIZE CODE NUMBER REV	
= .005 = 1/64 = 0°30'	PROD.	DATE	DFDRK01-X-14	
FINAL SURFACE QUALITY		DATE	DIST.	
REMOVE BURRS AND BREAK SHARP CORNERS		DATE		
MATERIAL	NEXT HIGHER ASSY	DATE		
FINISH	RK01	DATE		
	SCALE	DATE		
	SHEET	DATE		

Figure II-3 RK01 Flow Diagram

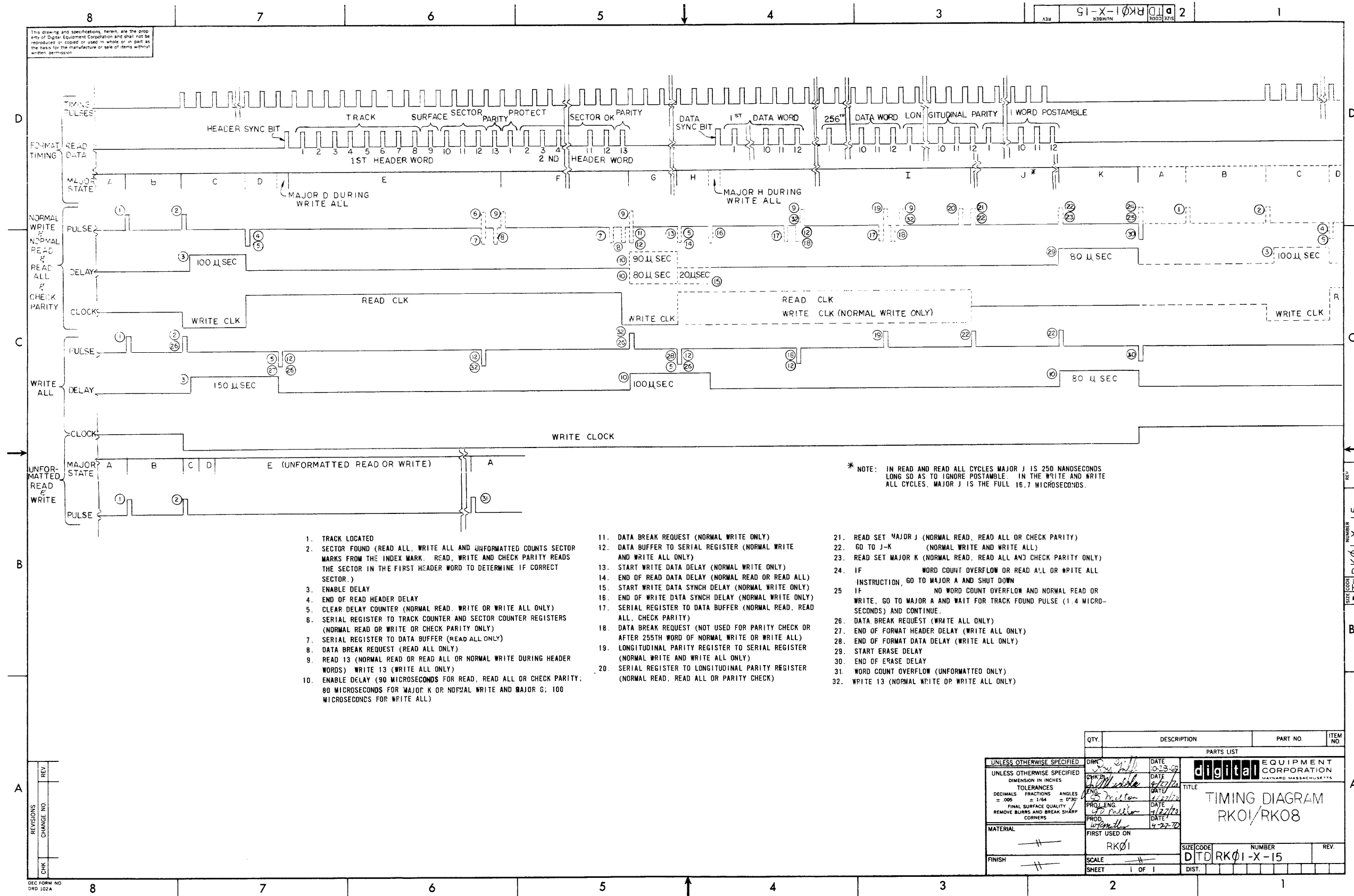

Figure II-4 RK01/RK08 Timing Diagram

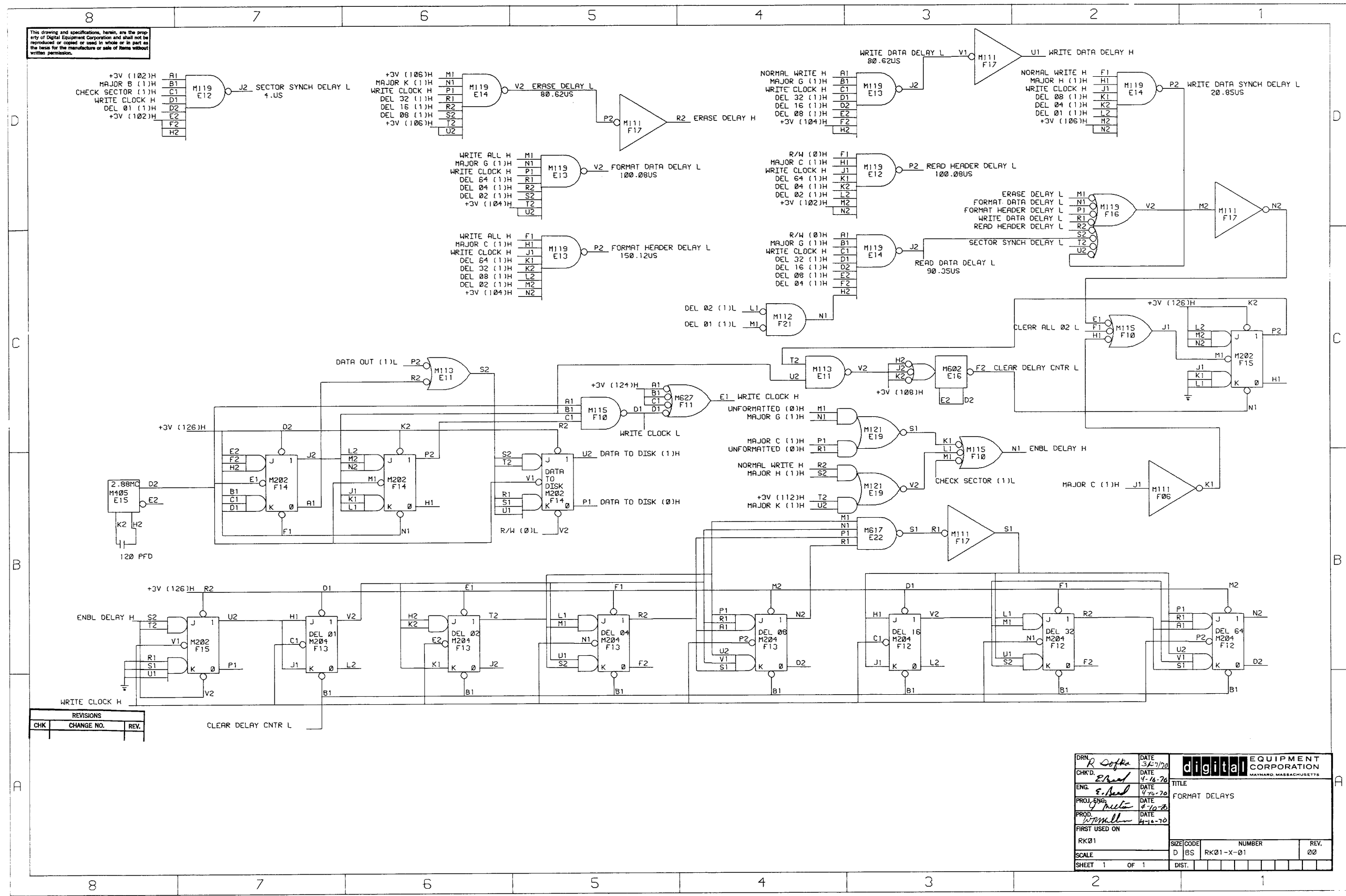

Figure II-5 Format Delays Block Schematic Diagram

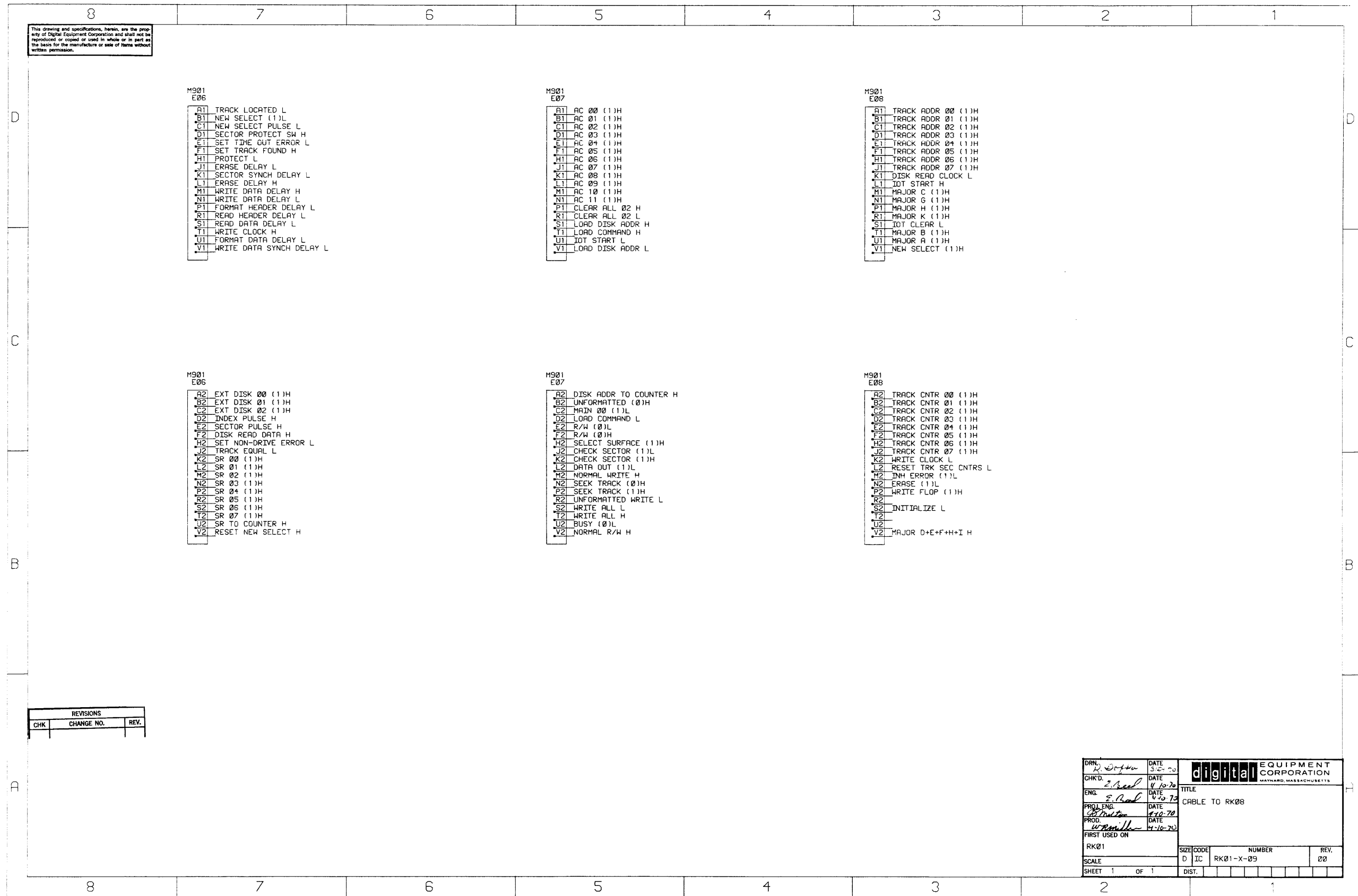

Figure II-6 Cable to RK08 Block Schematic Diagram

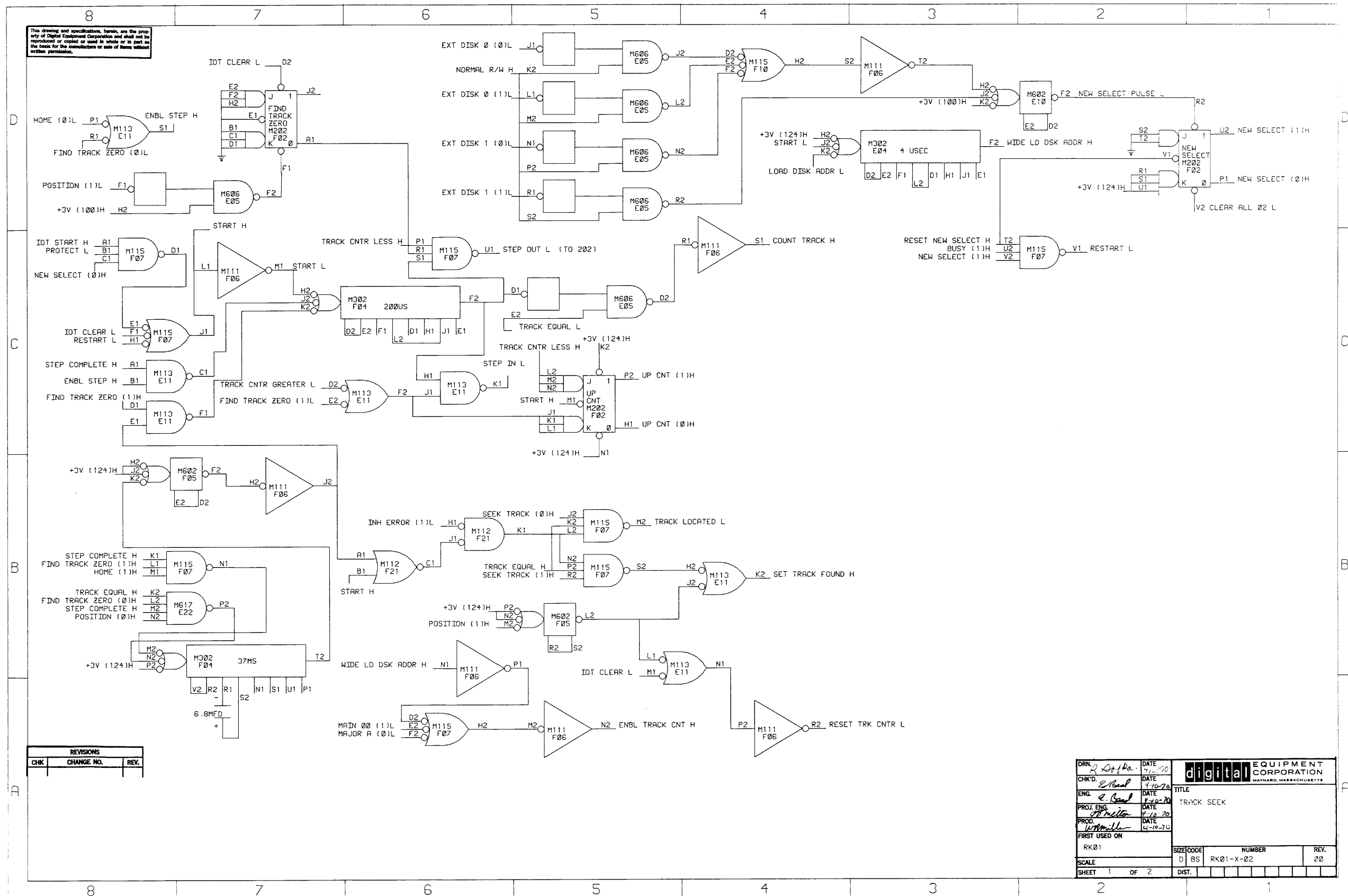
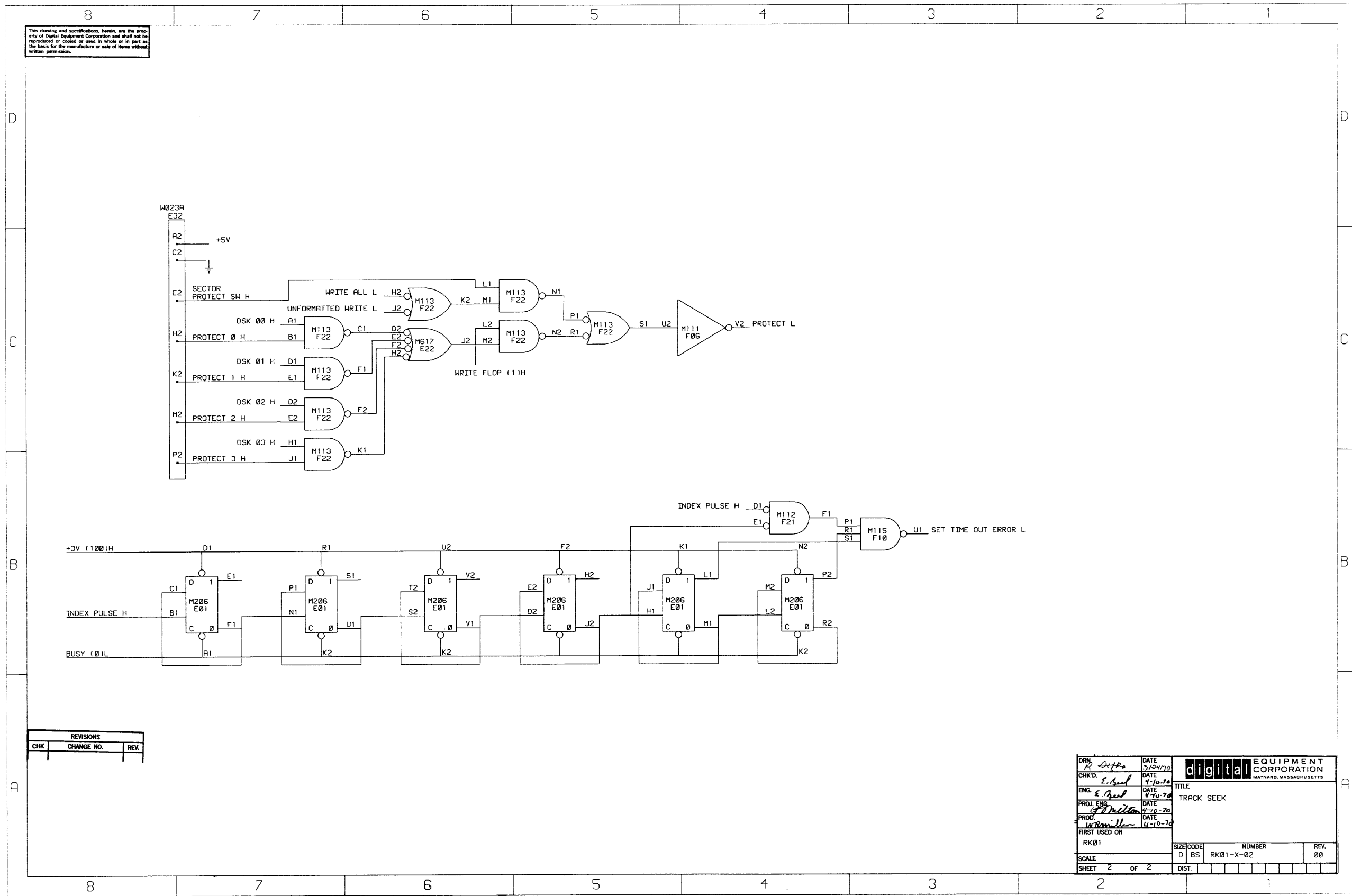

Figure II-7 Track Seek Block Schematic Diagram (Sheet 1)



REVISIONS		
CHK	CHANGE NO.	REV.

DRW <i>P. DiPa</i>	DATE 3/24/70	digital EQUIPMENT CORPORATION WAYNARD, MASSACHUSETTS
CHK'D <i>E. Reed</i>	DATE 4/10/70	
ENG <i>E. Reed</i>	DATE 4/10/70	TITLE TRACK SEEK
PROJ. ENG. <i>P. Miller</i>	DATE 4-10-70	SIZE CODE D BS
PROD. <i>W. Bonner</i>	DATE 4-10-70	
FIRST USED ON RK01	SCALE	NUMBER RK01-X-02
SHEET 2 OF 2	DIST.	REV. 00

Figure II-7 Track Seek Block Schematic Diagram (Sheet 2)

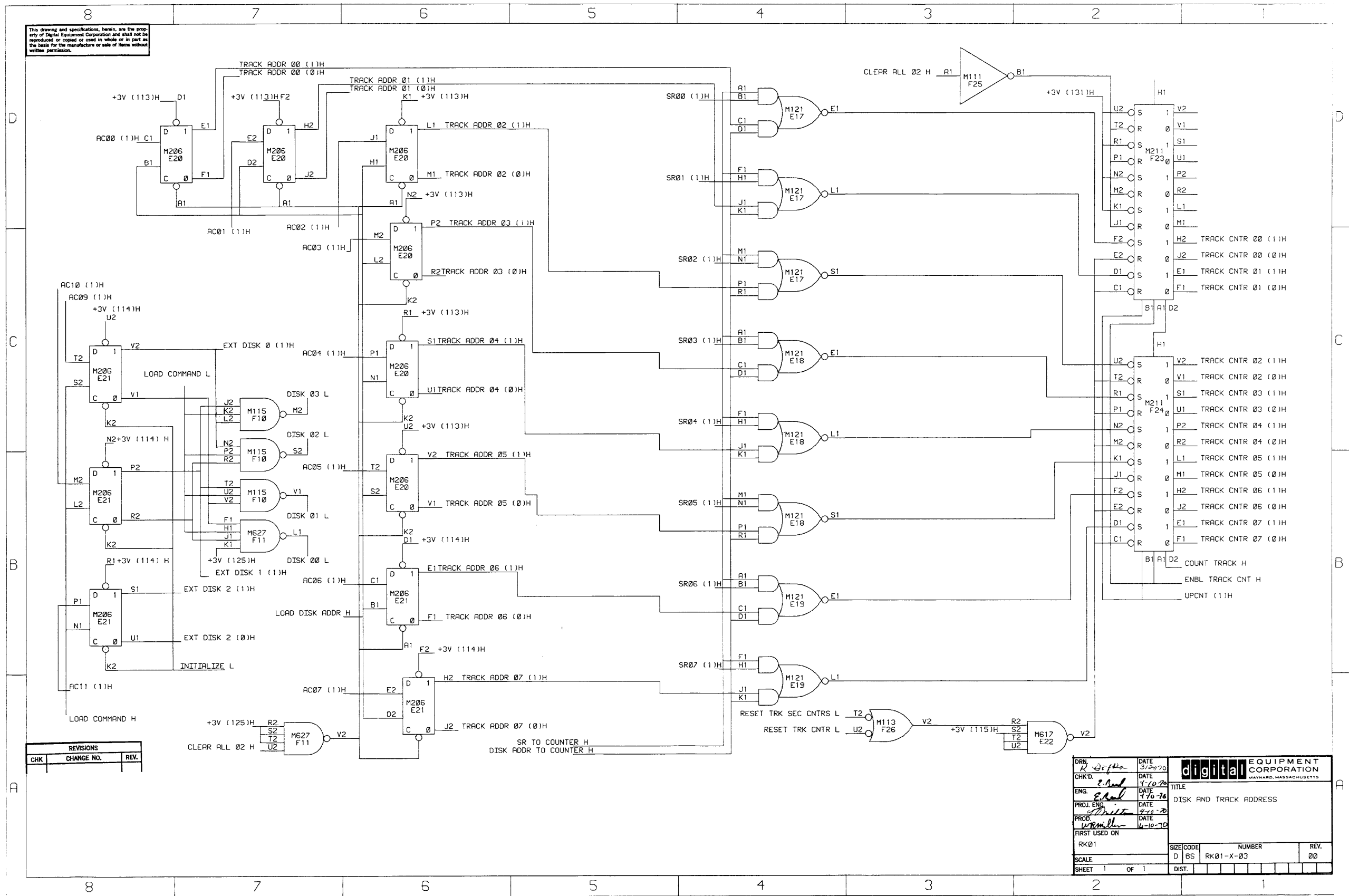

Figure II-8 Disk and Track Address Block Schematic Diagram

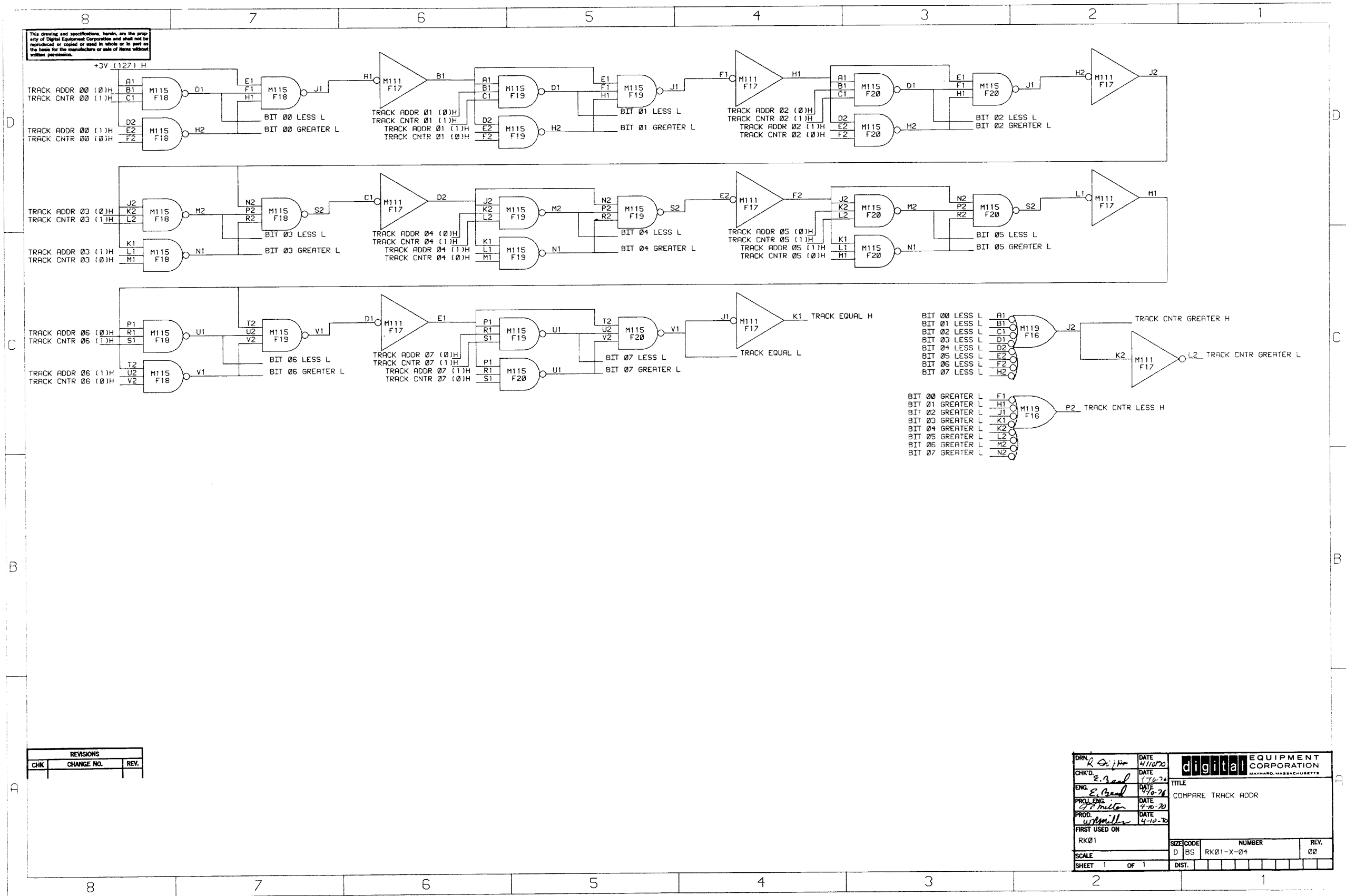

Figure II-9 Compare Track Address Block Schematic Diagram

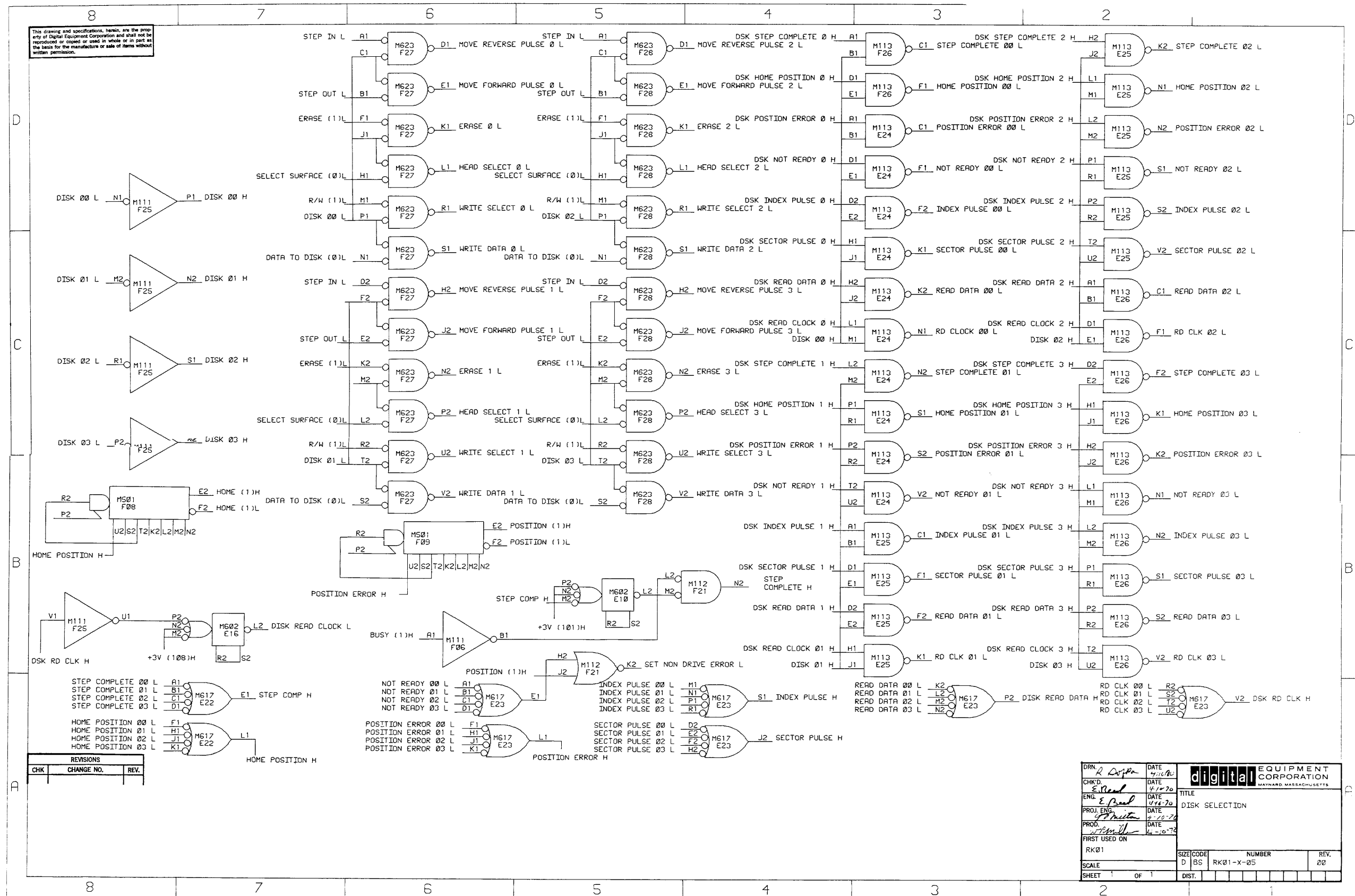

Figure II-10 Disk Selection Block Schematic Diagram

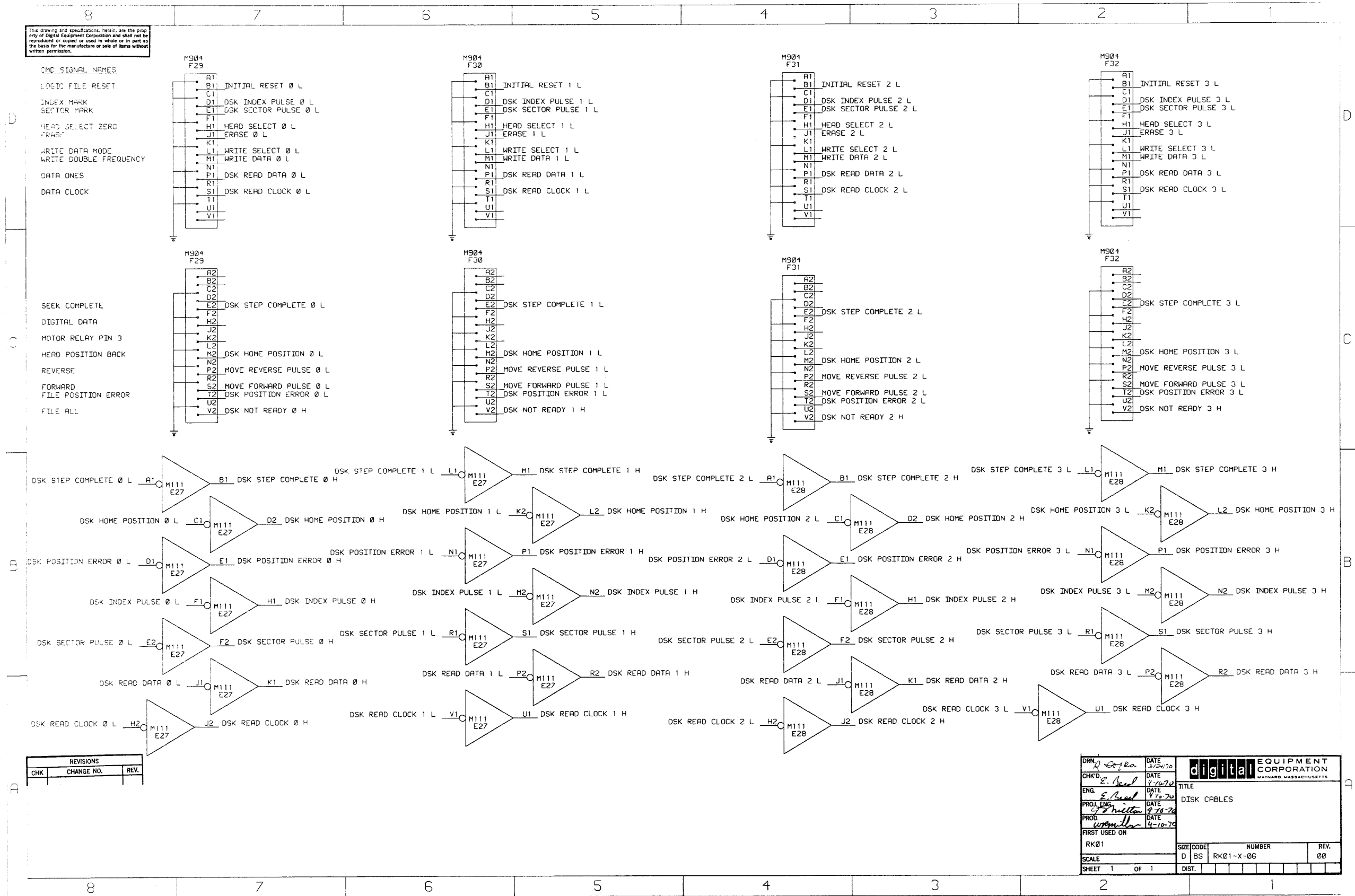

Figure II-11 Disk Cables Block Schematic Diagram

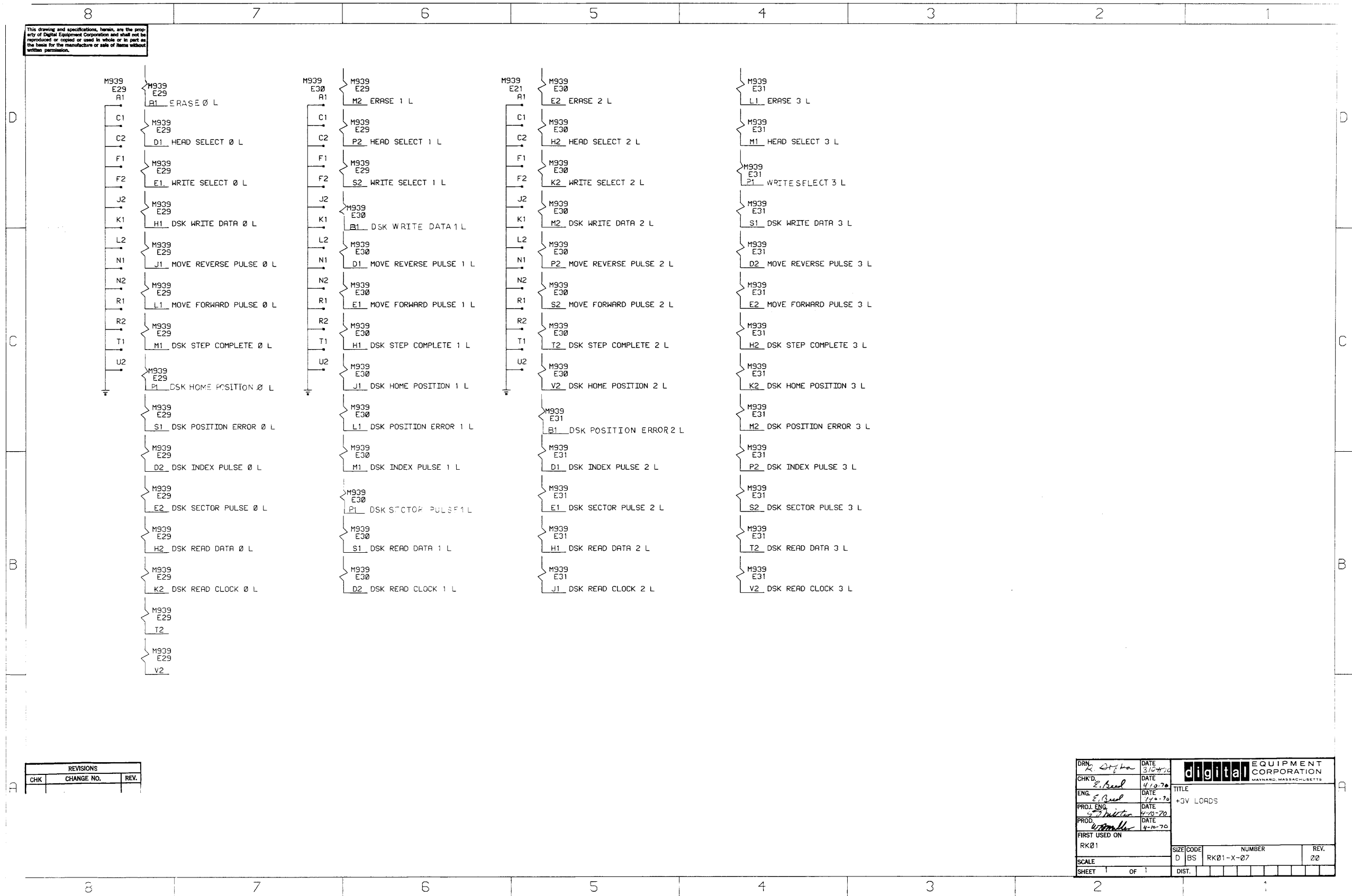

Figure II-12 +3V Loads Block Schematic Diagram

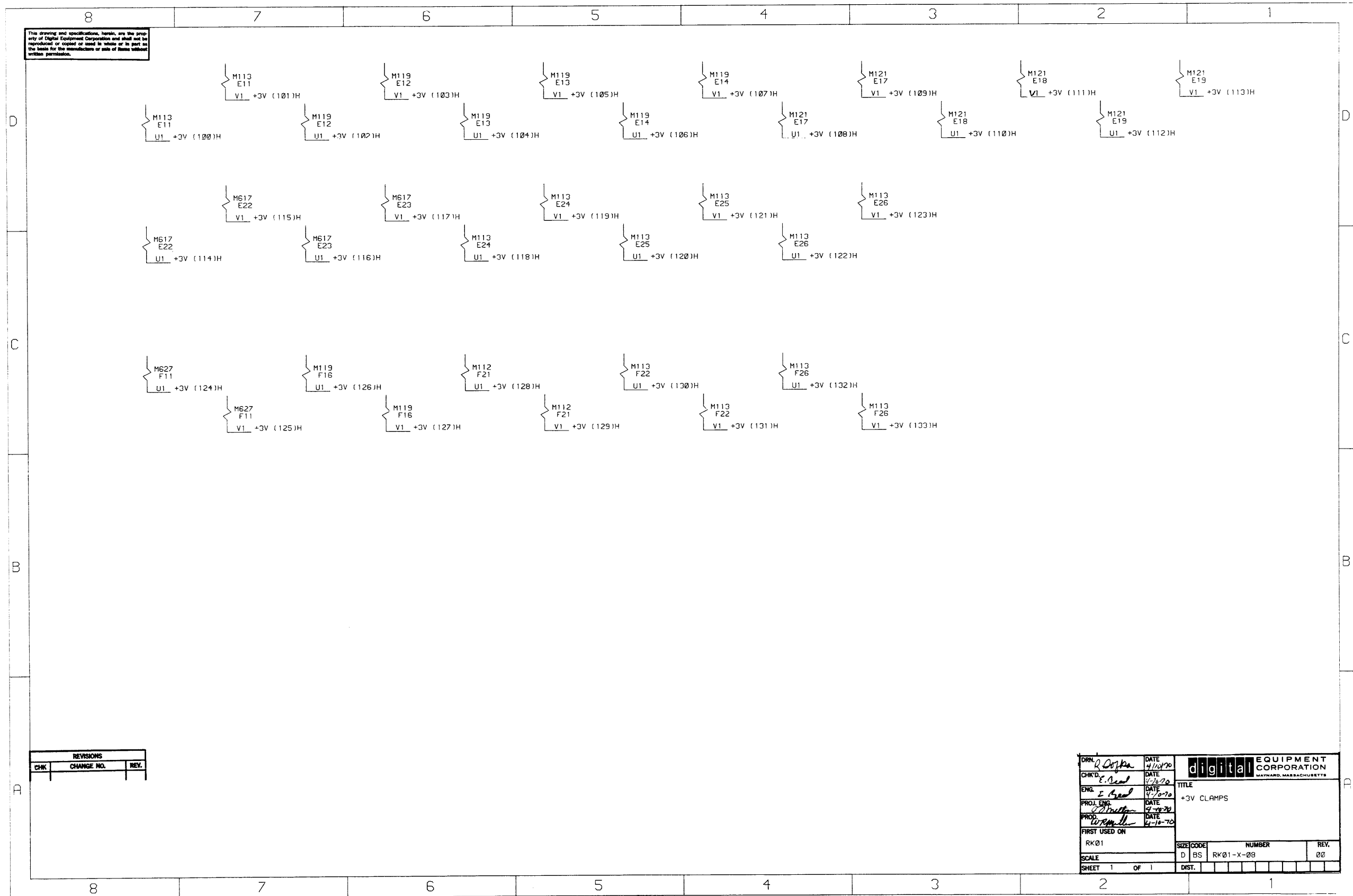

Figure II-13 +3V Clamp Block Schematic Diagram

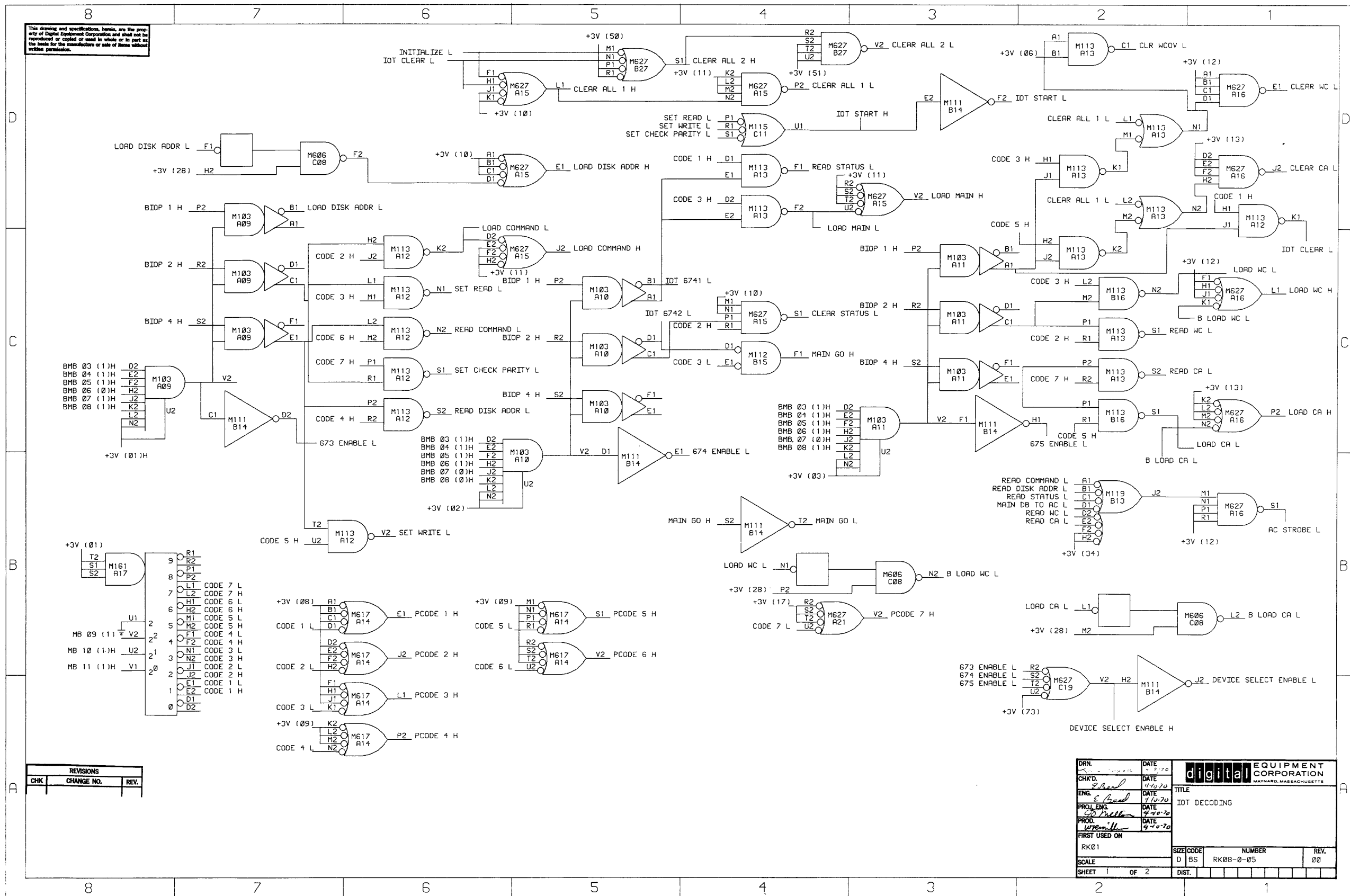

Figure II-14 IOT Decoding Block Schematic Diagram

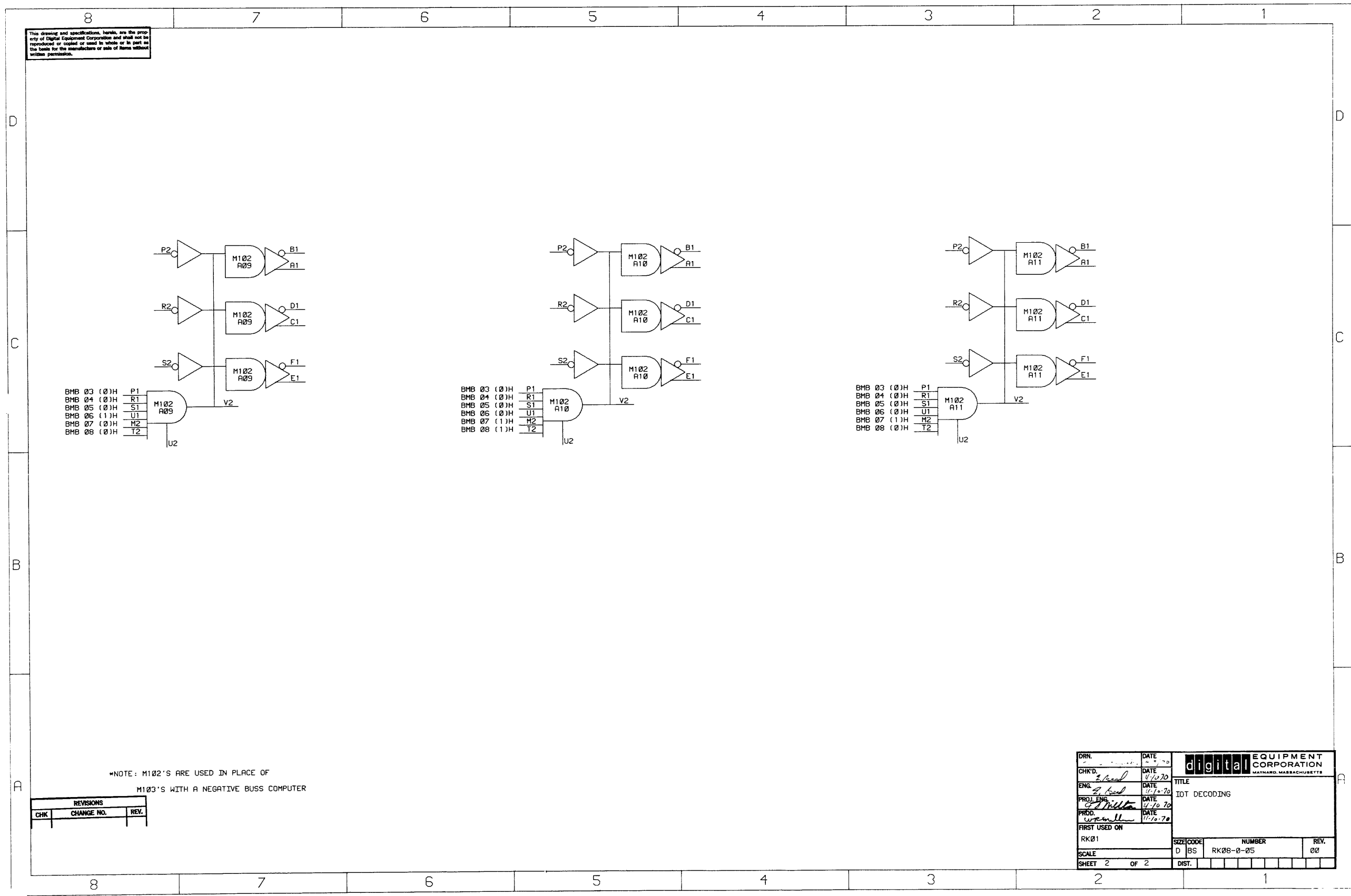

Figure II-15 IOT Decoding Block Schematic Diagram

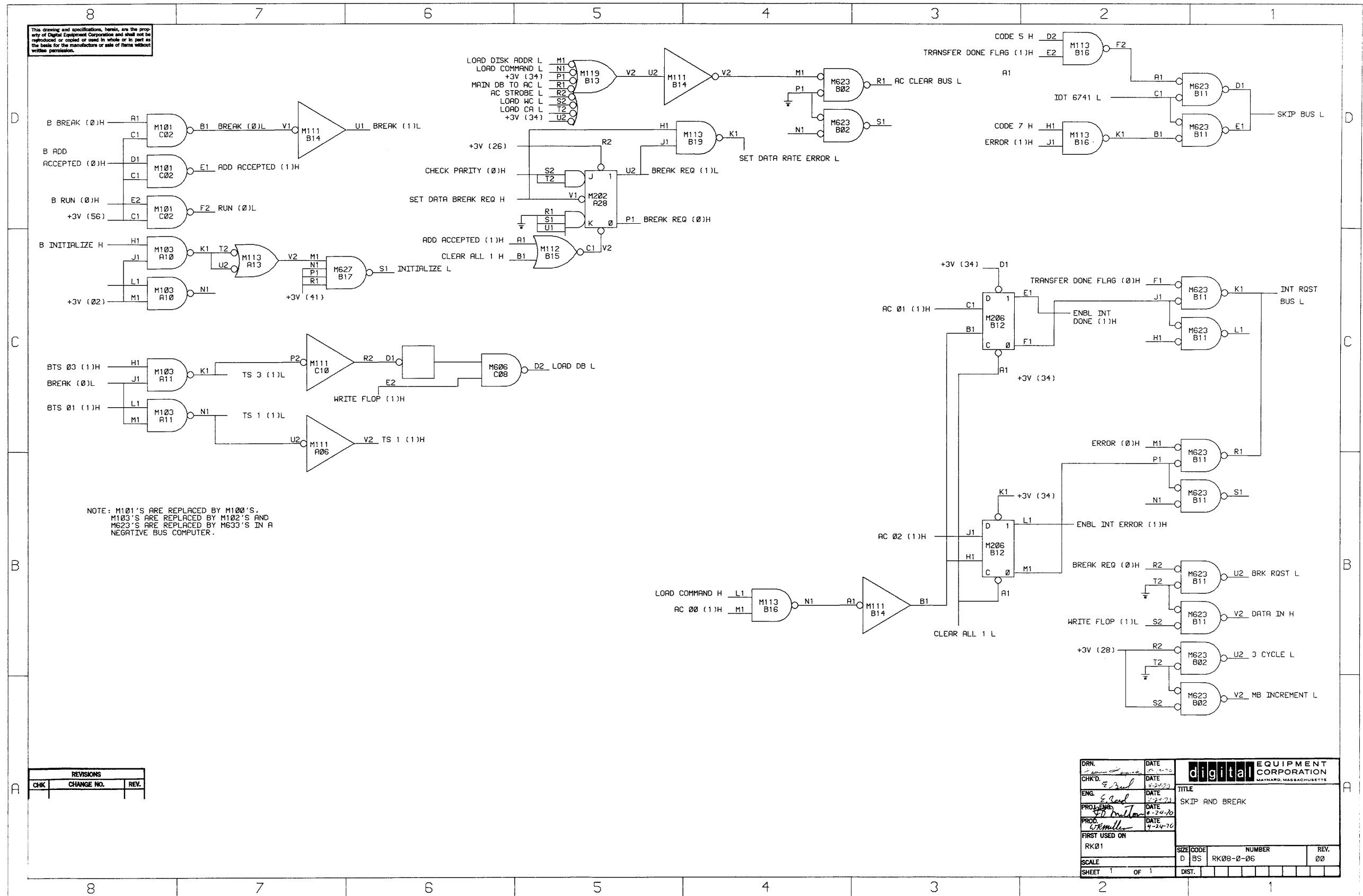

Figure II-16 Skip and Break Block Schematic Diagram

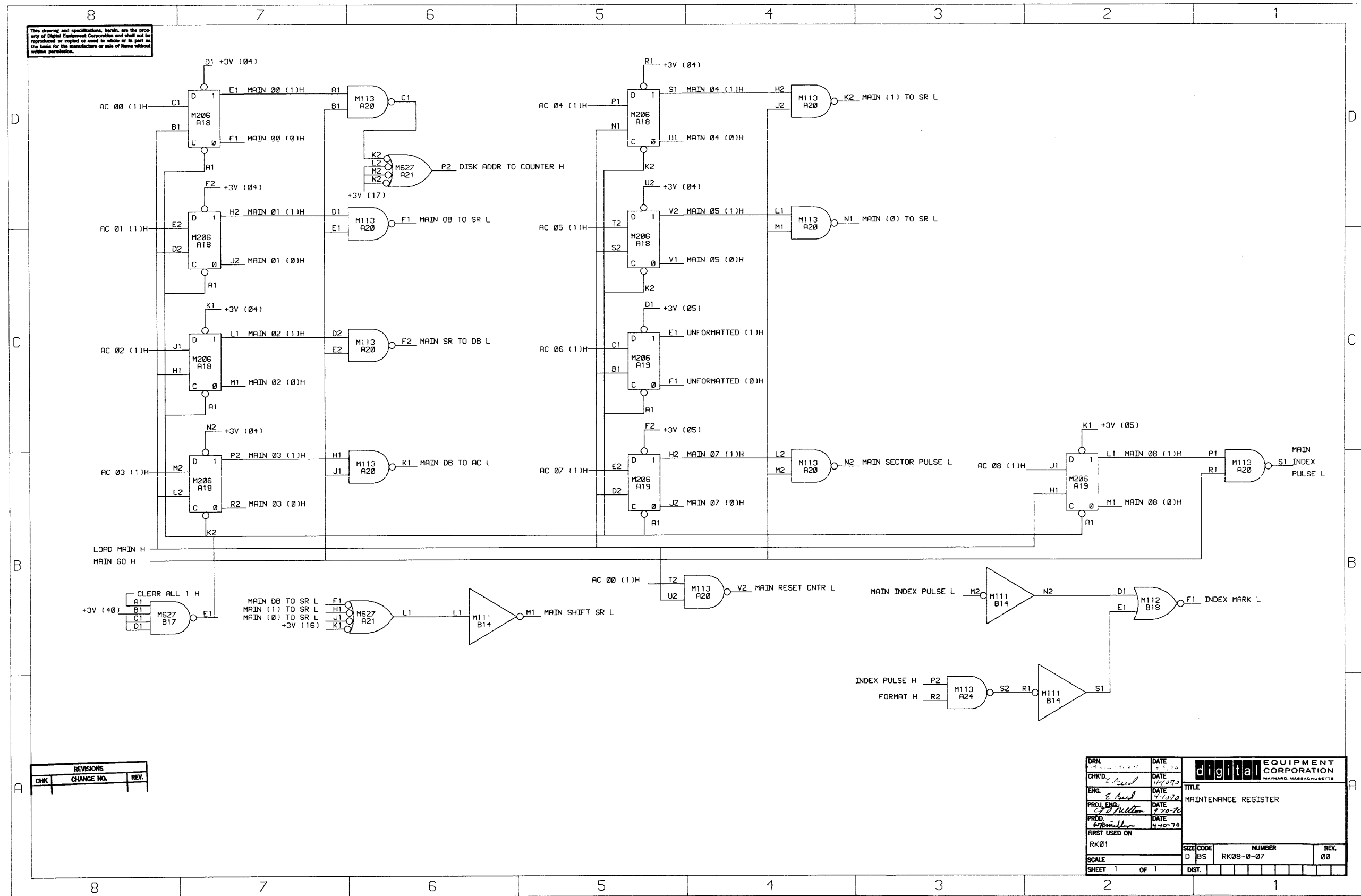

Figure II-17 Maintenance Register Block Schematic Diagram

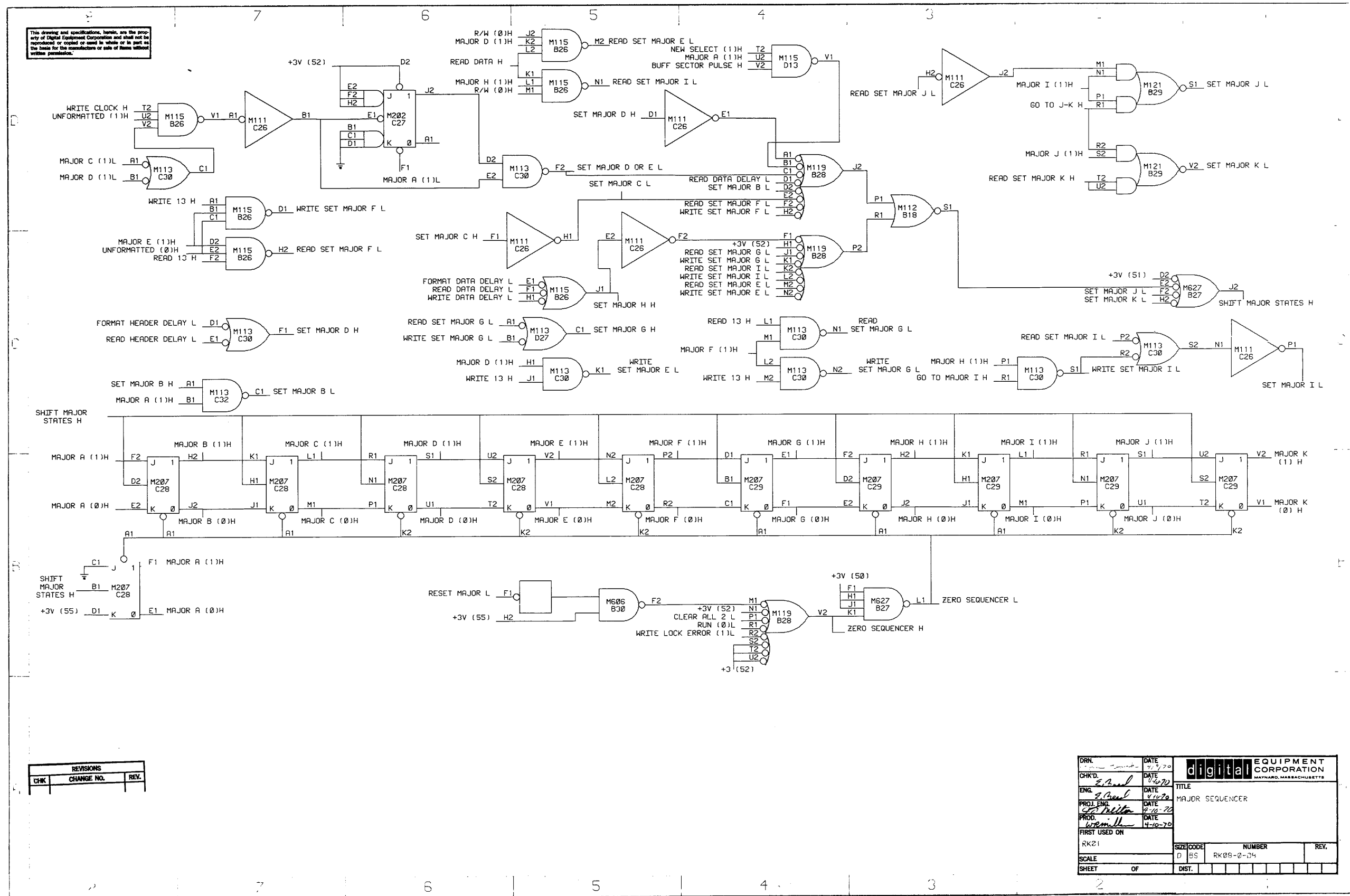

Figure II-18 Major Sequencer Register Block Schematic Diagram

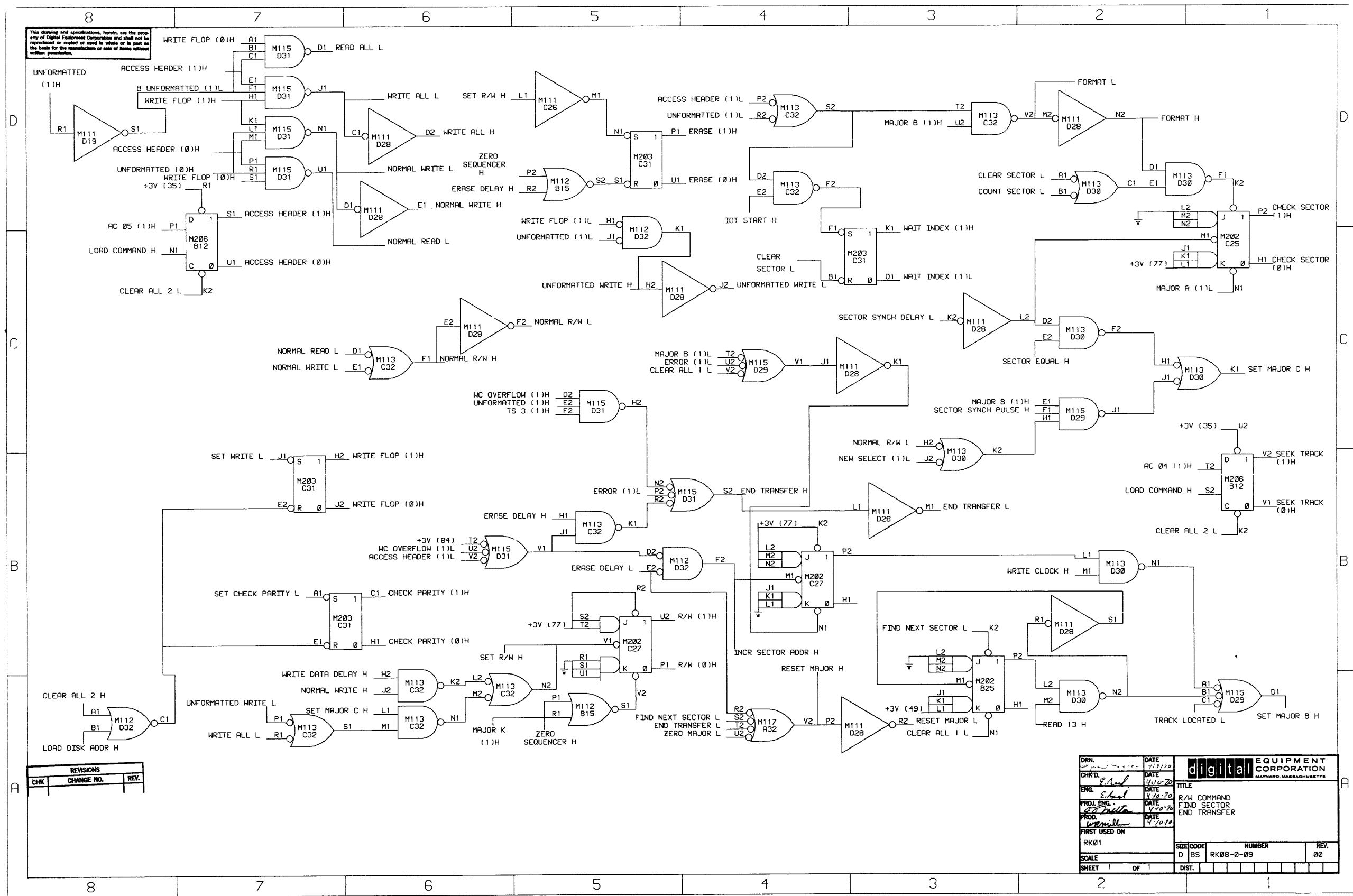

Figure II-19 R/W Command, Find Sector, End transfer Block Schematic Diagram

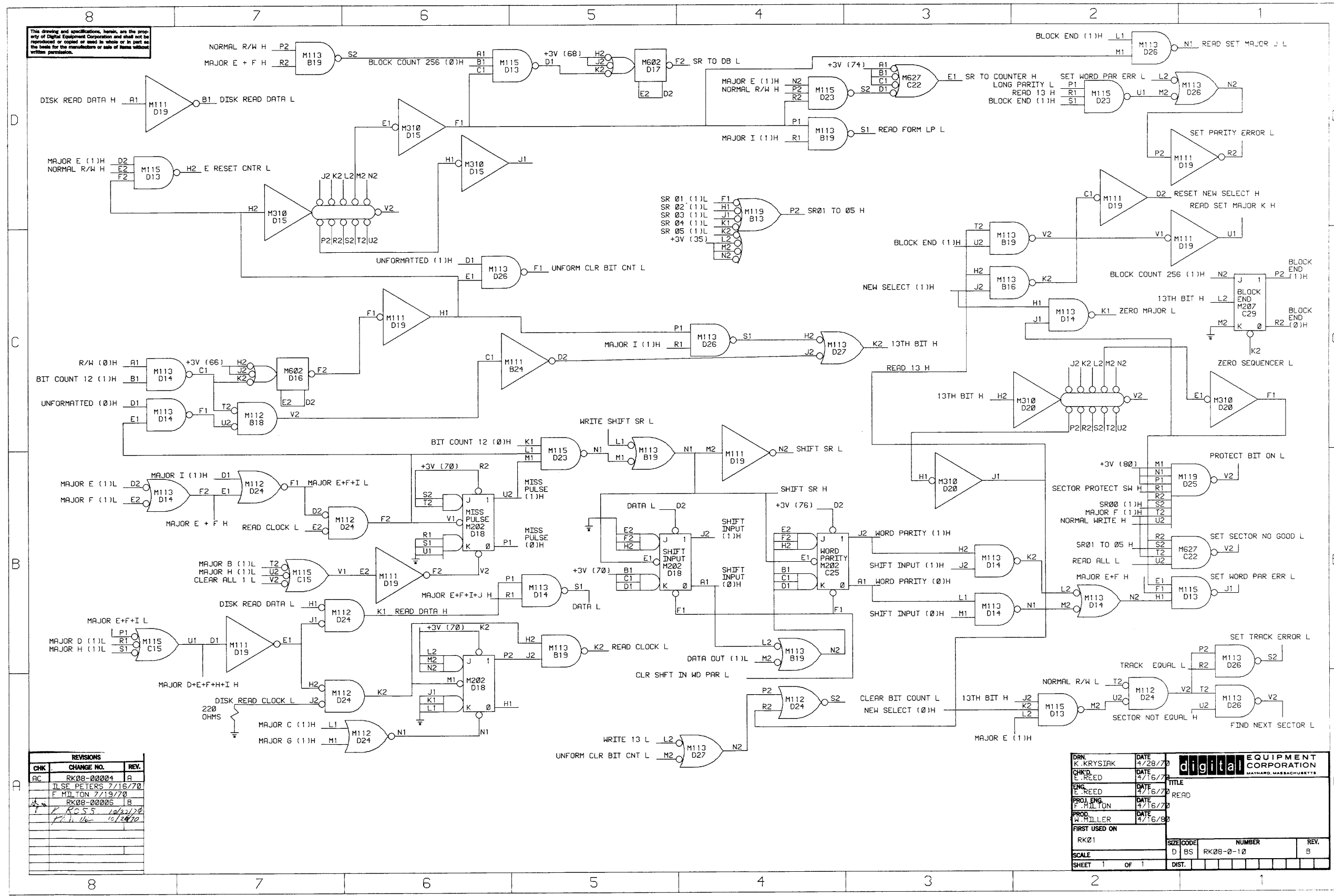

Figure II-20 Read Block Schematic Diagram

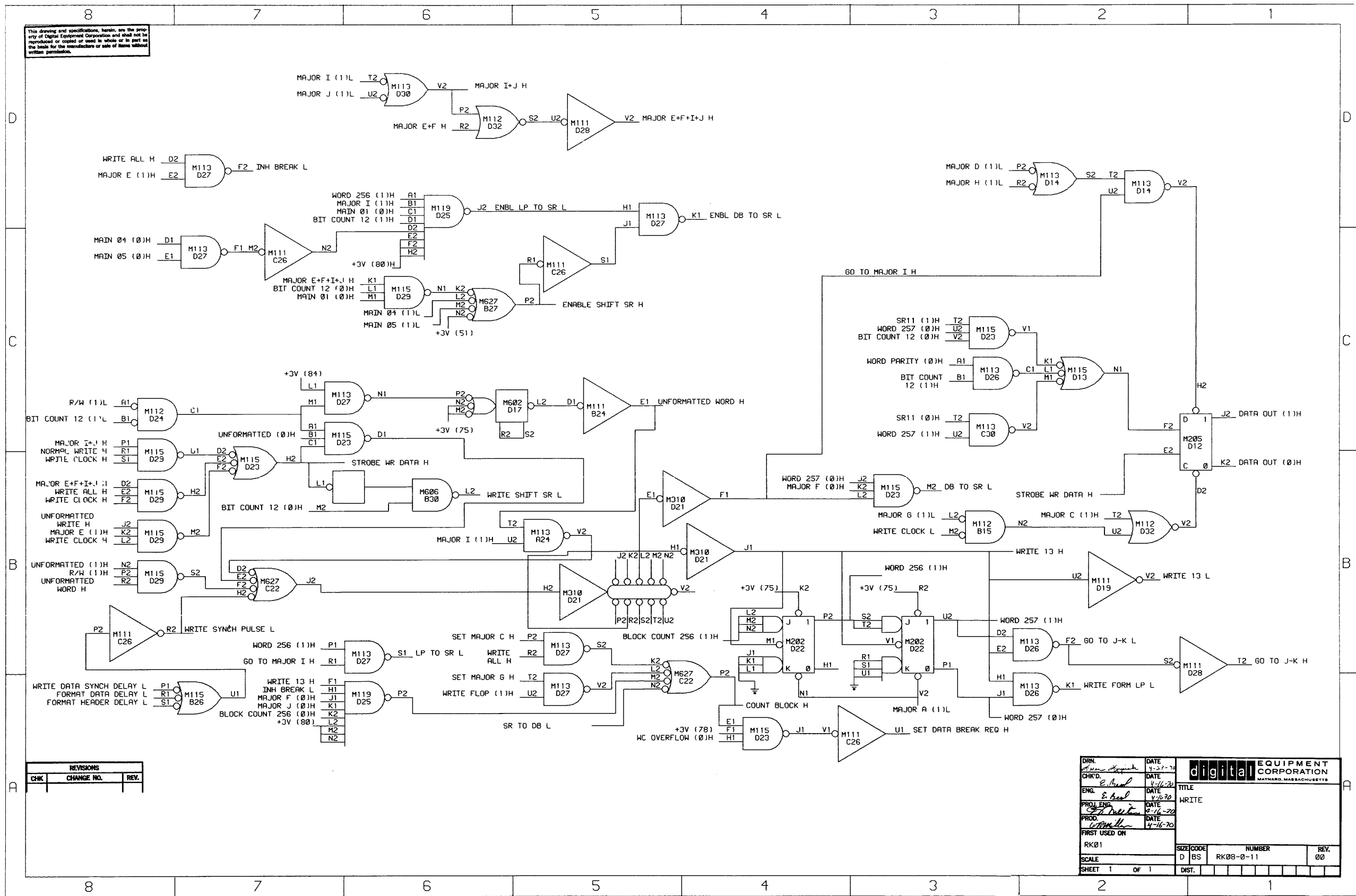

Figure II-21 Write Block Schematic Diagram

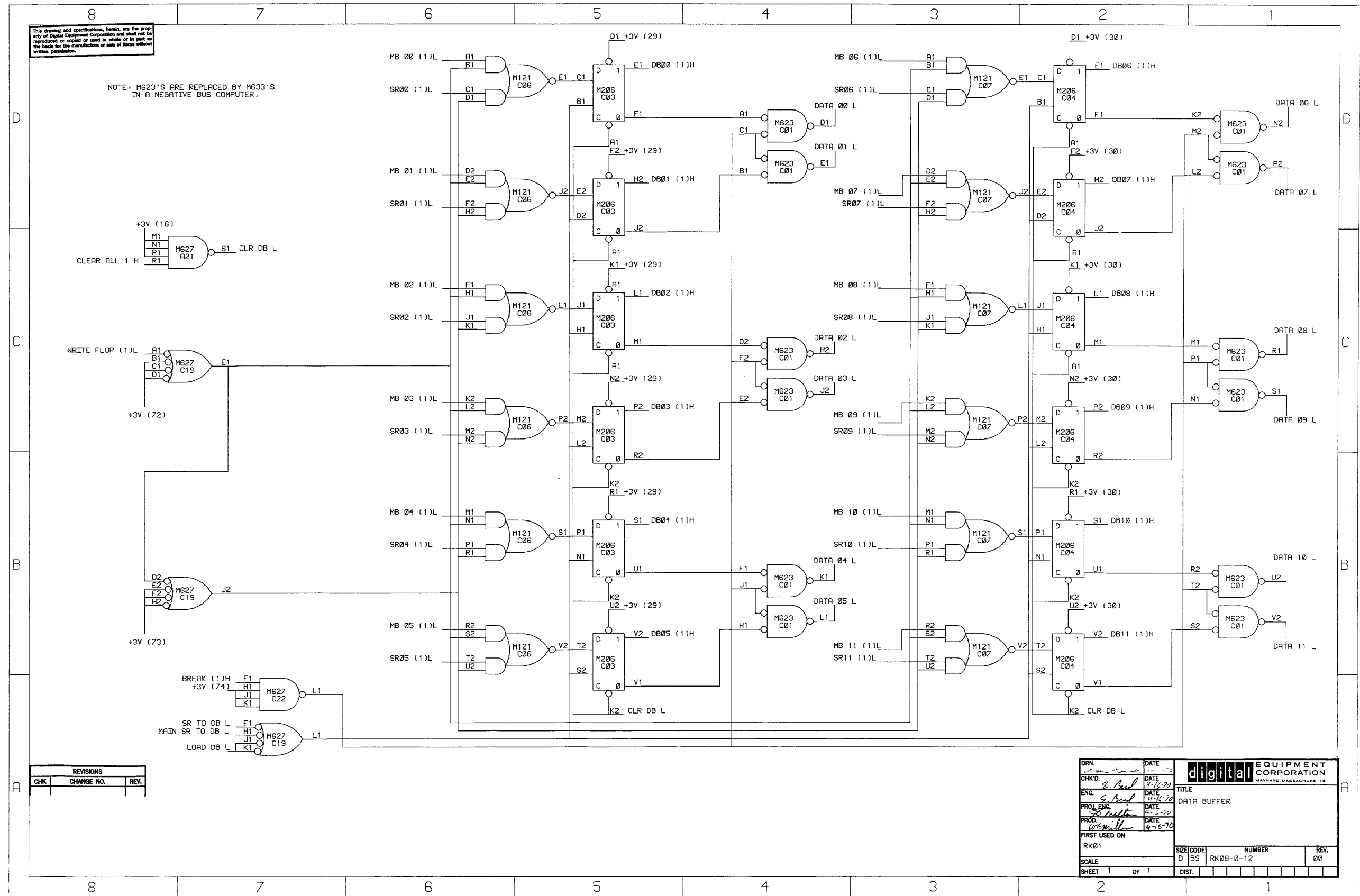

Figure II-22 Data Buffer Block Schematic Diagram

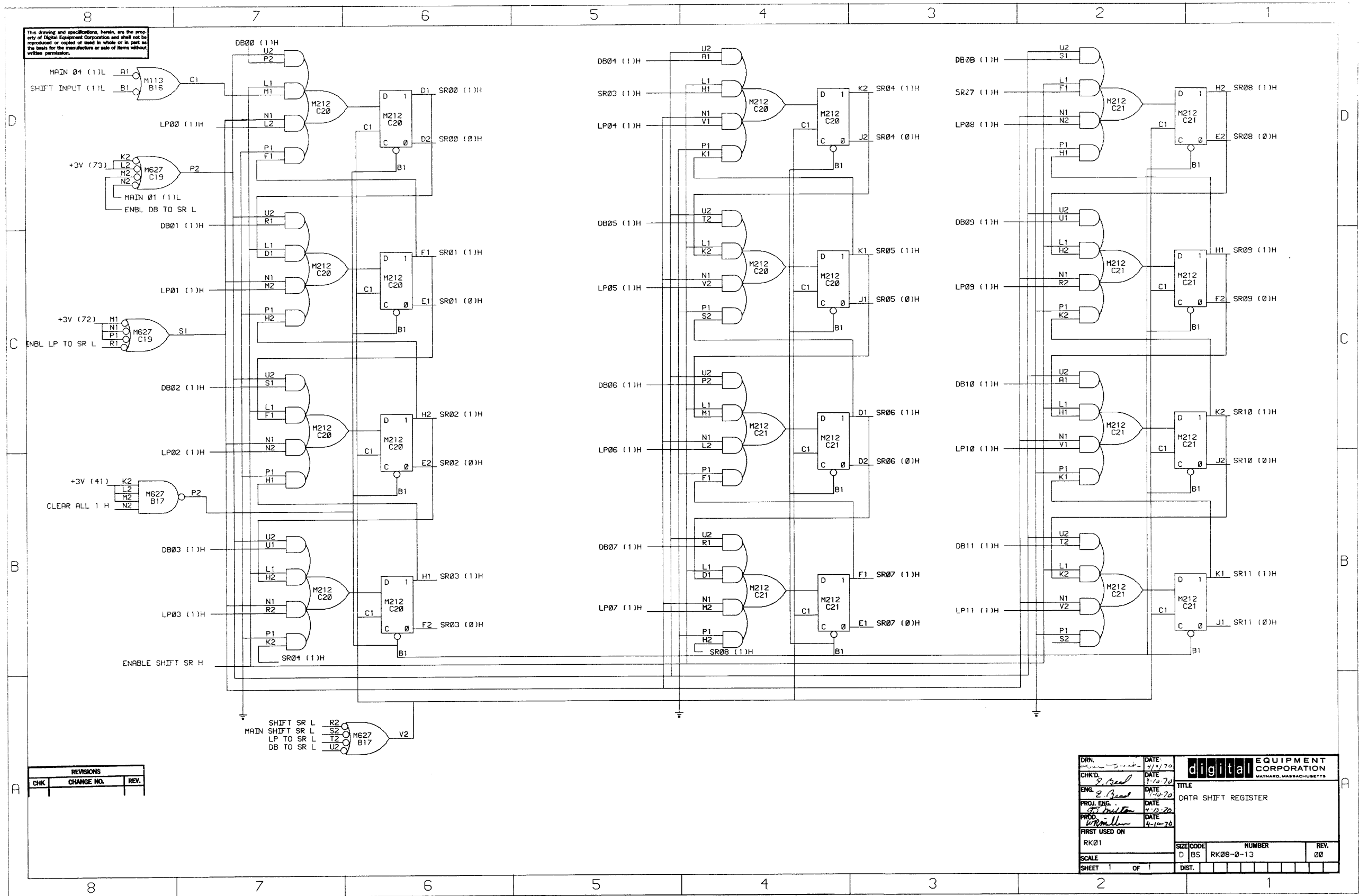

Figure II-23 Data Shift Register Block Schematic Diagram

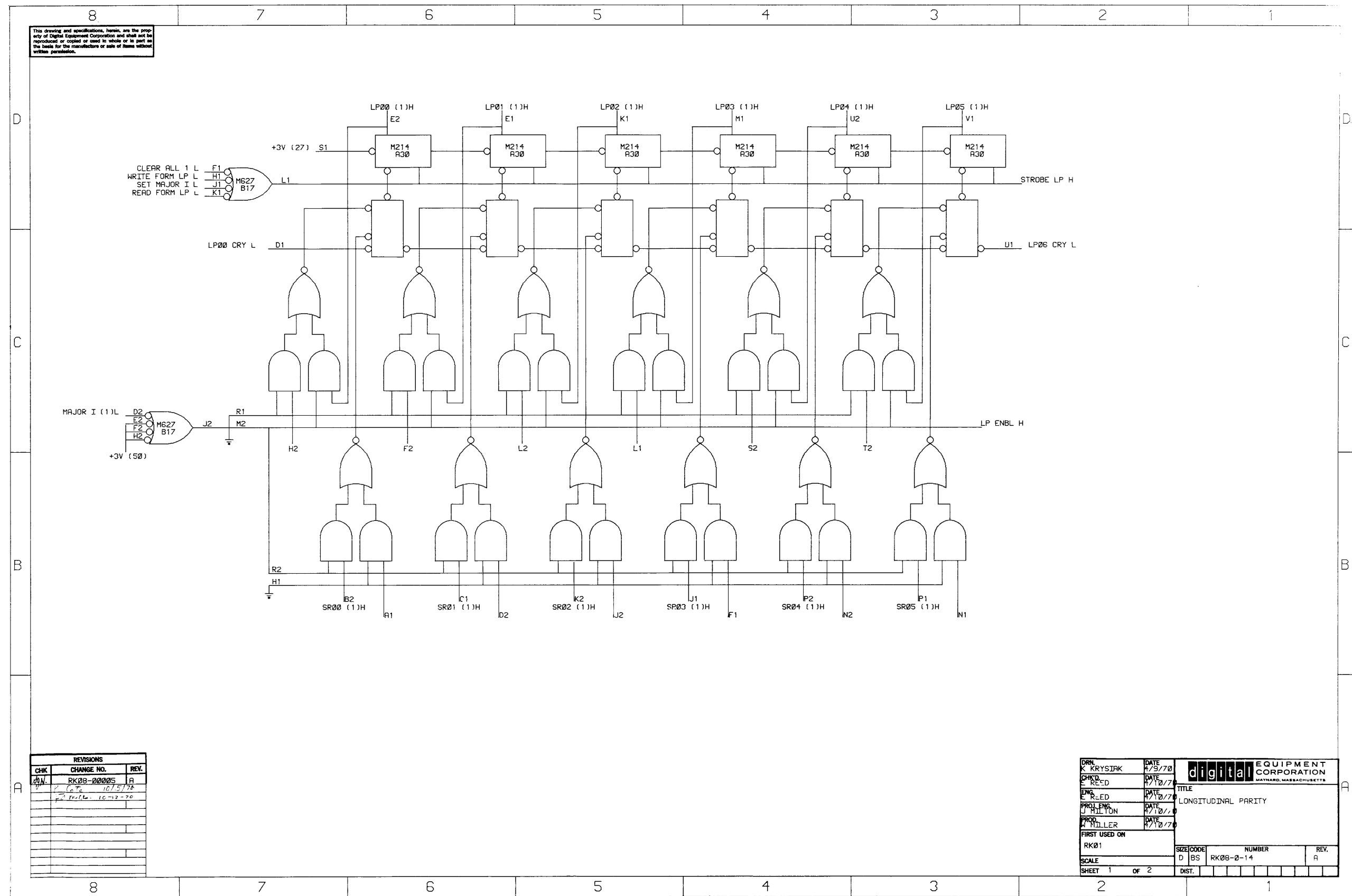
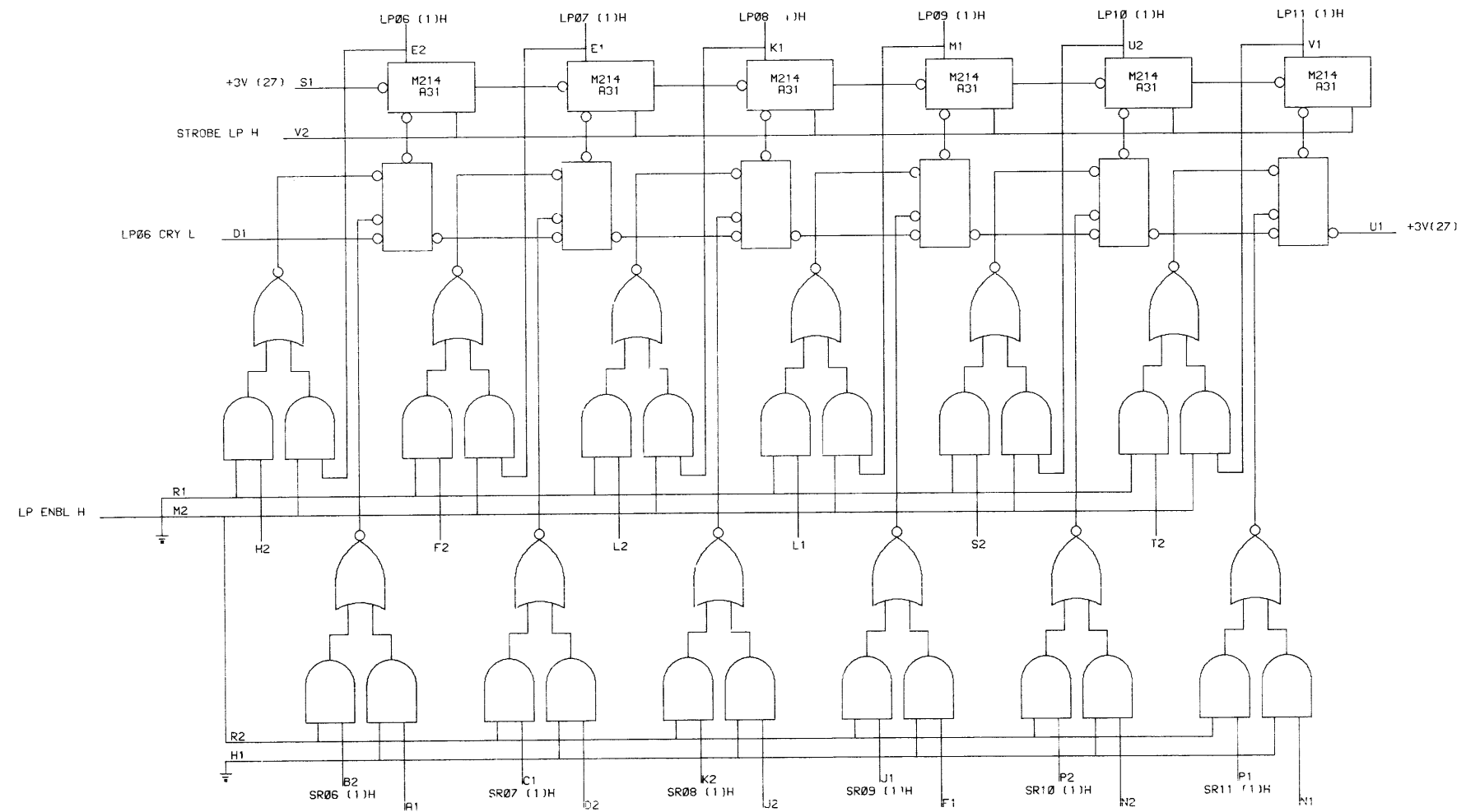

Figure II-24 Longitudinal Parity Block Schematic Diagram
(Sheet 1 of 2)

This drawing and specifications, herein, are the property of Digital Equipment Corporation and shall not be reproduced or copied or used in whole or in part as the basis for the manufacture or sale of items without written permission.



REVISIONS		
CHK	CHANGE NO.	REV.

DRN K. KRYSIAK	DATE 4/9/70	 digital EQUIPMENT CORPORATION MAYNARD, MASSACHUSETTS
CHKD E. REED	DATE 4/10/70	
ENG E. REED	DATE 4/10/70	
PROL ENG J. HILTON	DATE 4/10/70	
PROB W. MILLER	DATE 4/10/70	
FIRST USED ON RK01		TITLE LONGITUDINAL PARITY
SCALE SHEET 2 OF 2	SIZE CODE D BS	NUMBER RK00-0-14
	DIST.	REV. A

Figure II-25 Longitudinal Parity Block Schematic Diagram
(Sheet 2 of 2)

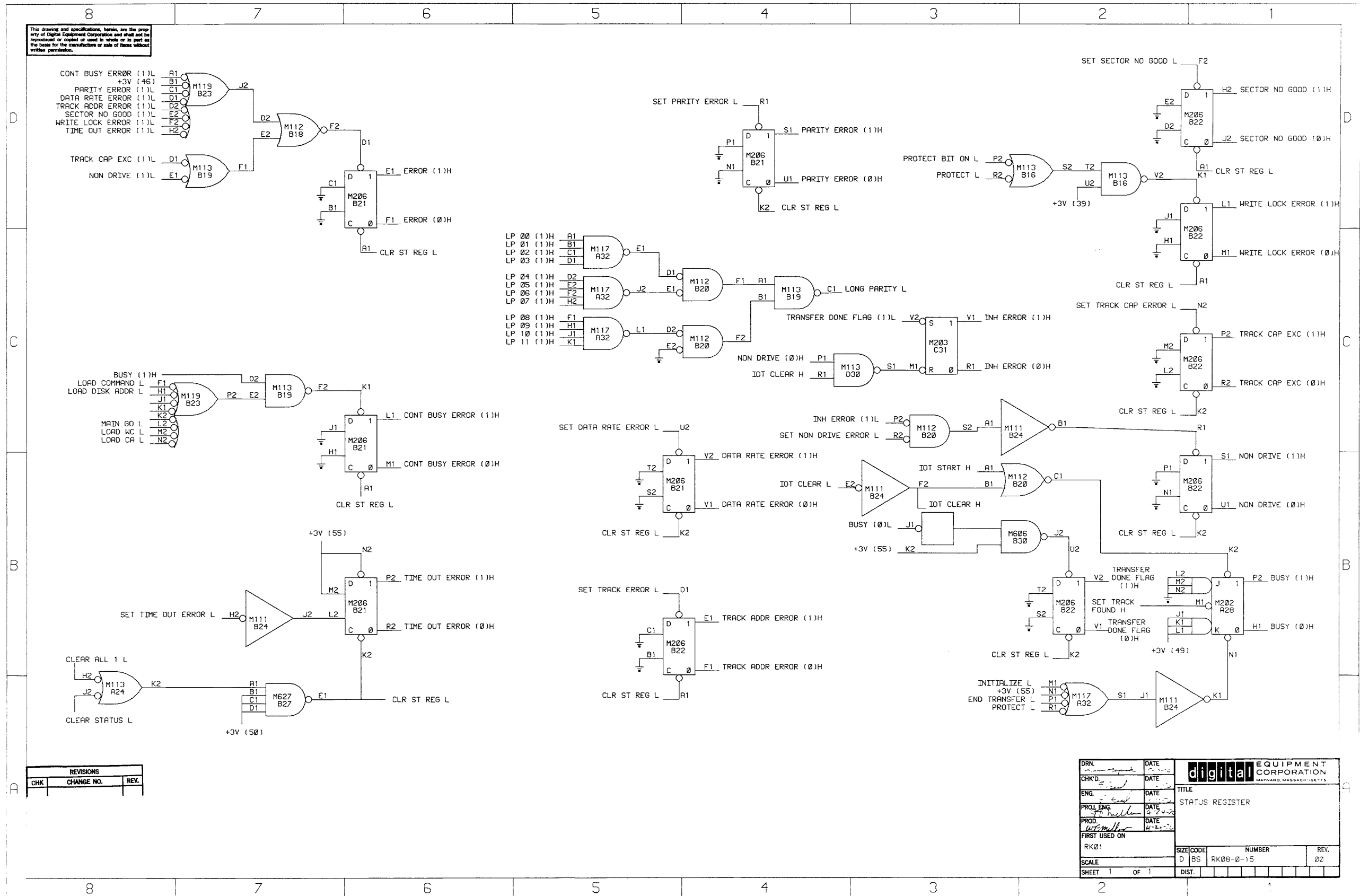

This drawing and specifications, herein, are the property of Digital Equipment Corporation and shall not be reproduced or copied or used in whole or in part as the basis for the manufacture or sale of items without written permission.

REVISIONS		
CHK	CHANGE NO.	REV.

DRN.	DATE	digital EQUIPMENT CORPORATION MAYNARD, MASSACHUSETTS
CHK'D	DATE	
ENG.	DATE	TITLE
PROJ. ENG.	DATE	STATUS REGISTER
PROD.	DATE	
FIRST USED ON		
RK01		
SCALE	SIZE CODE	NUMBER
SHEET 1 OF 1	DIST.	RK08-0-15
		REV. 02

Figure II-26 Status Register Block Schematic Diagram

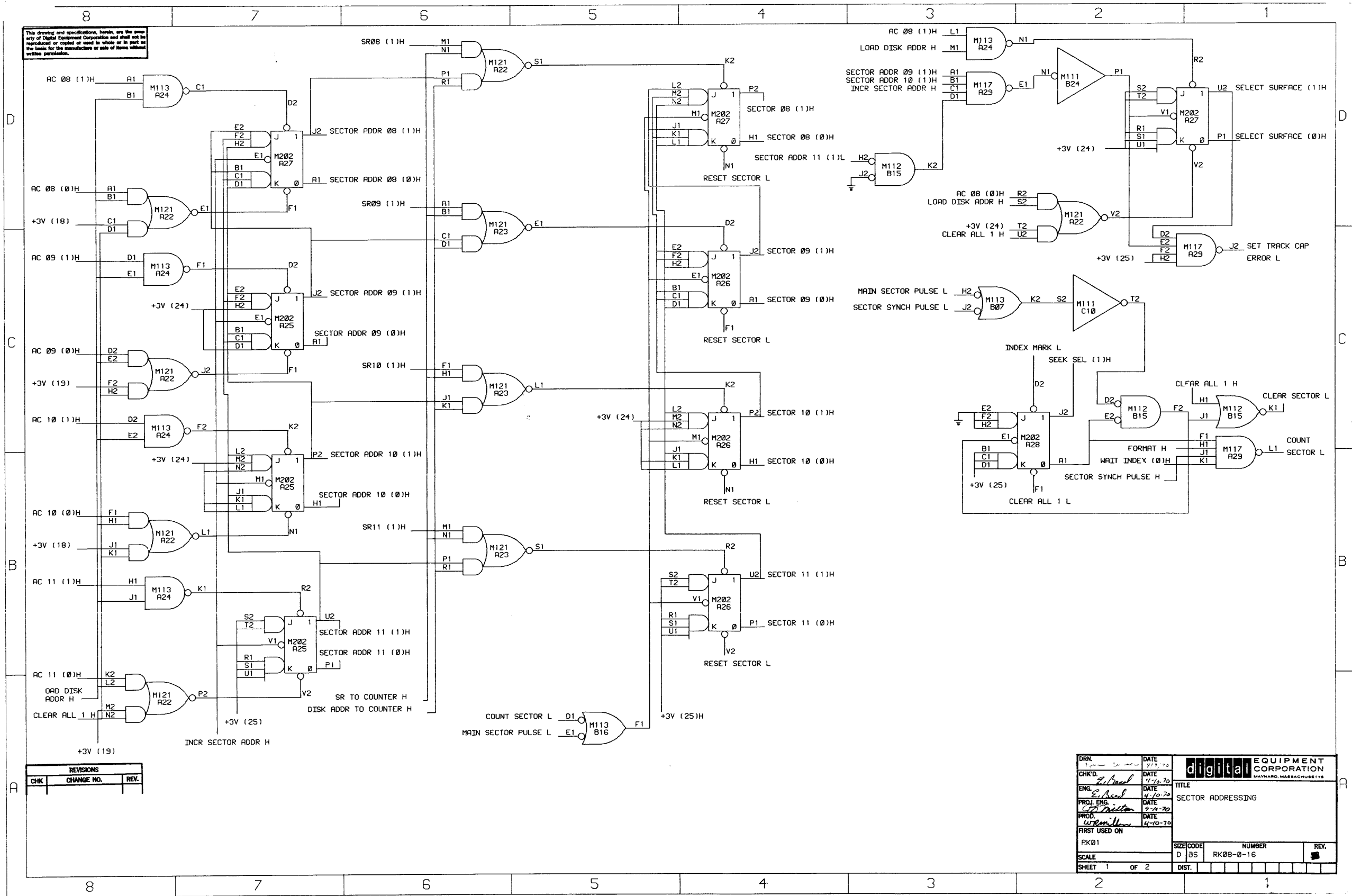

Figure II-27 Sector Addressing Block Schematic Diagram
(Sheet 1 of 2)

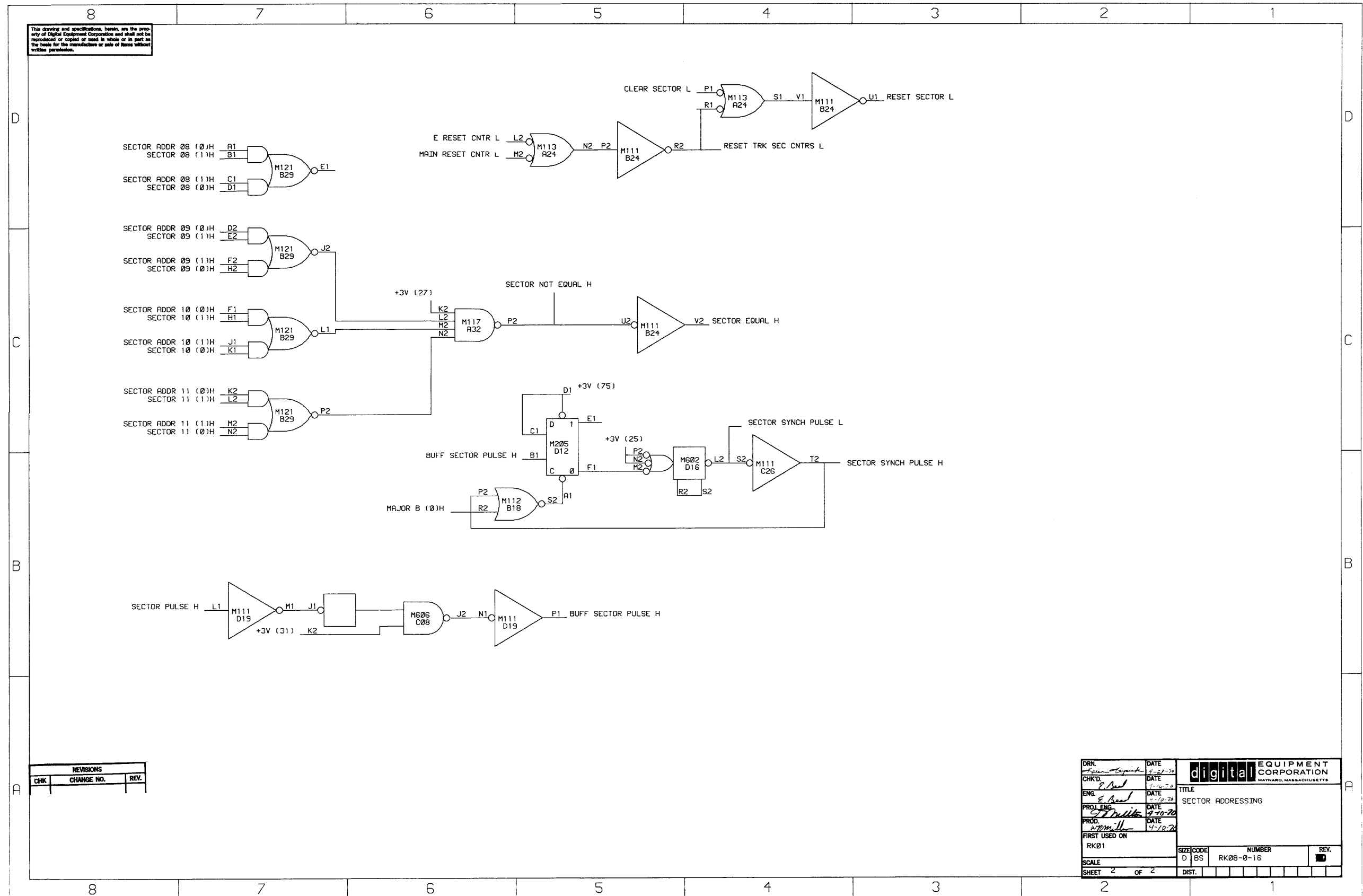
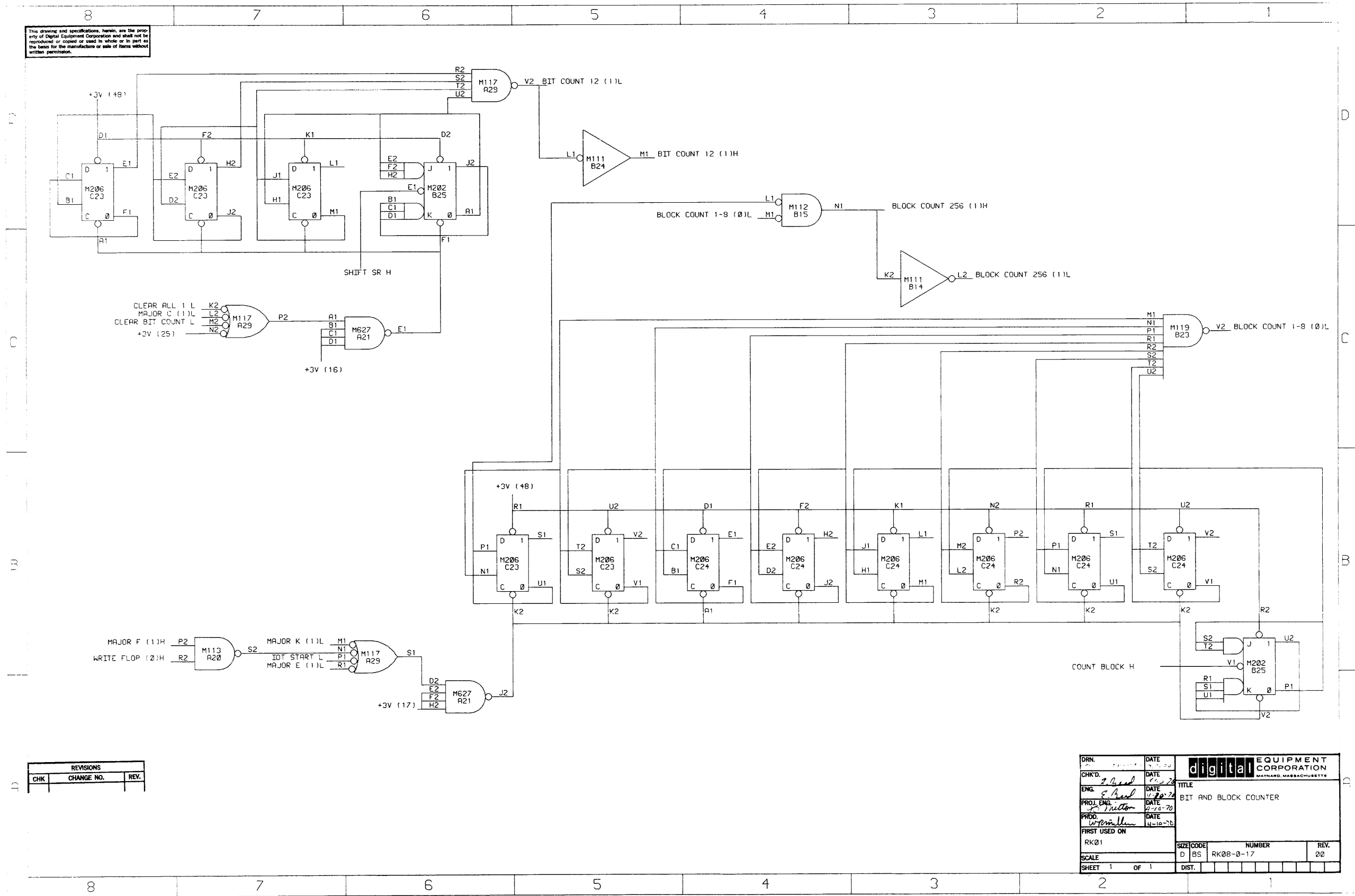

Figure II-28 Sector Addressing Block Schematic Diagram
(Sheet 2 of 2)



REVISIONS		
CHK	CHANGE NO.	REV.

DRN.	DATE	digital EQUIPMENT CORPORATION MAYNARD, MASSACHUSETTS	TITLE BIT AND BLOCK COUNTER
CHK'D.	DATE		
ENG.	DATE		
PROJ. ENG.	DATE		
PROD.	DATE		
FIRST USED ON		SIZE	NUMBER
RK01		D BS	RK08-0-17
SCALE	SHEET	DIST.	REV.
1 OF 1	1		00

Figure II-29 Bit and Block Counter Block Schematic Diagram

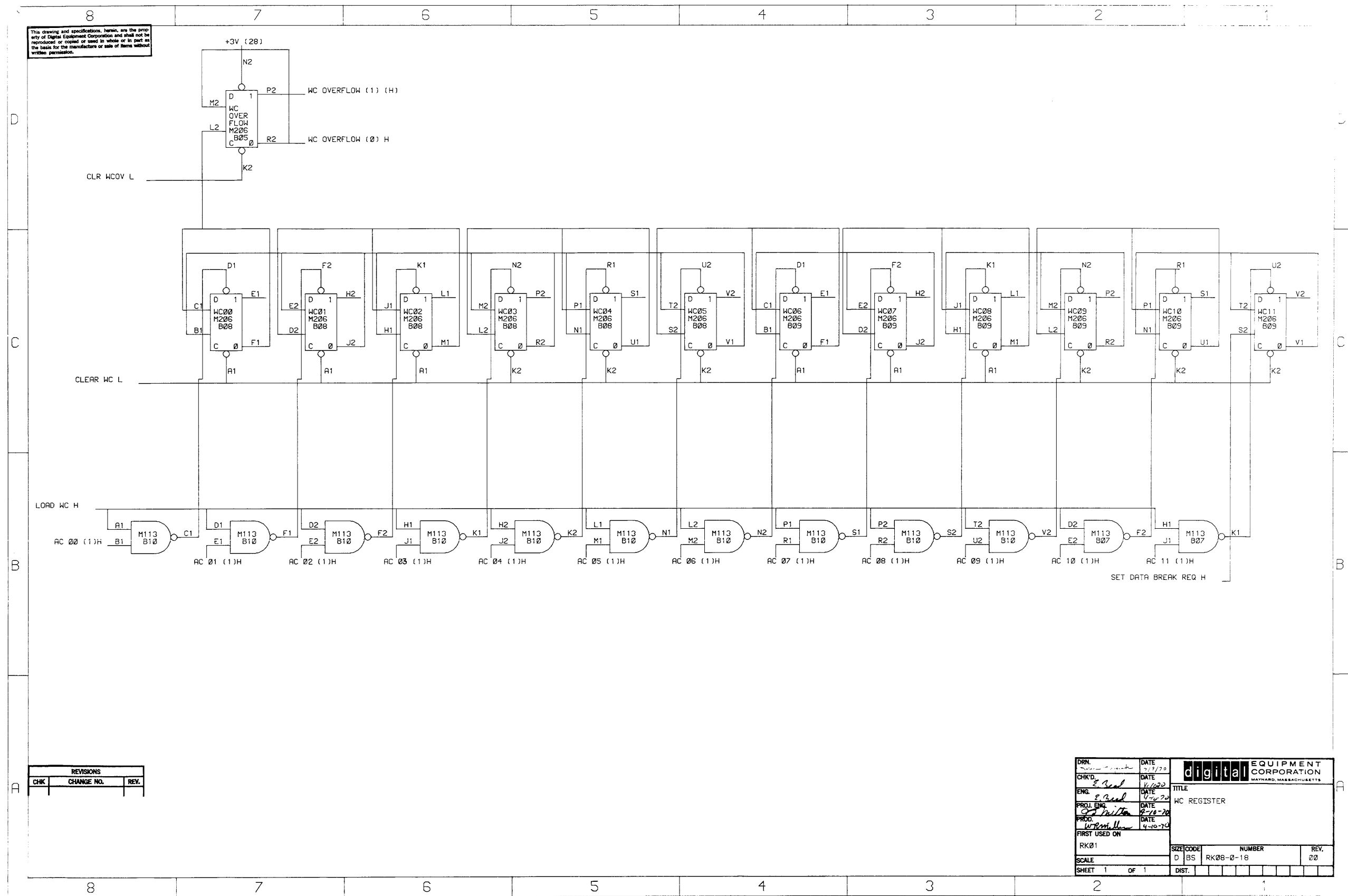

Figure II-30 Word Count (WC) Register Block Schematic Diagram

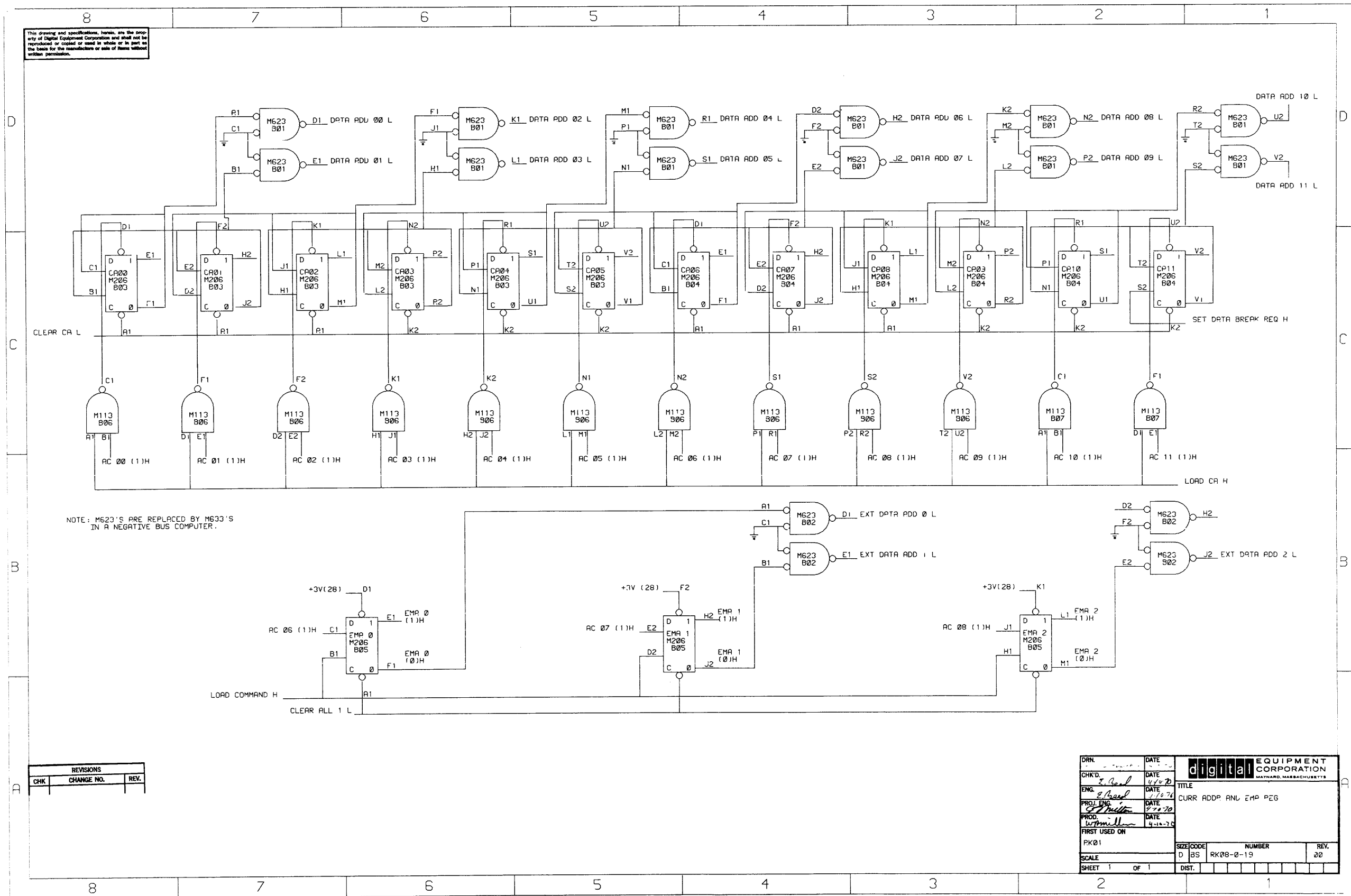

Figure II-31 Current Address and EMA Register Block Schematic Diagram

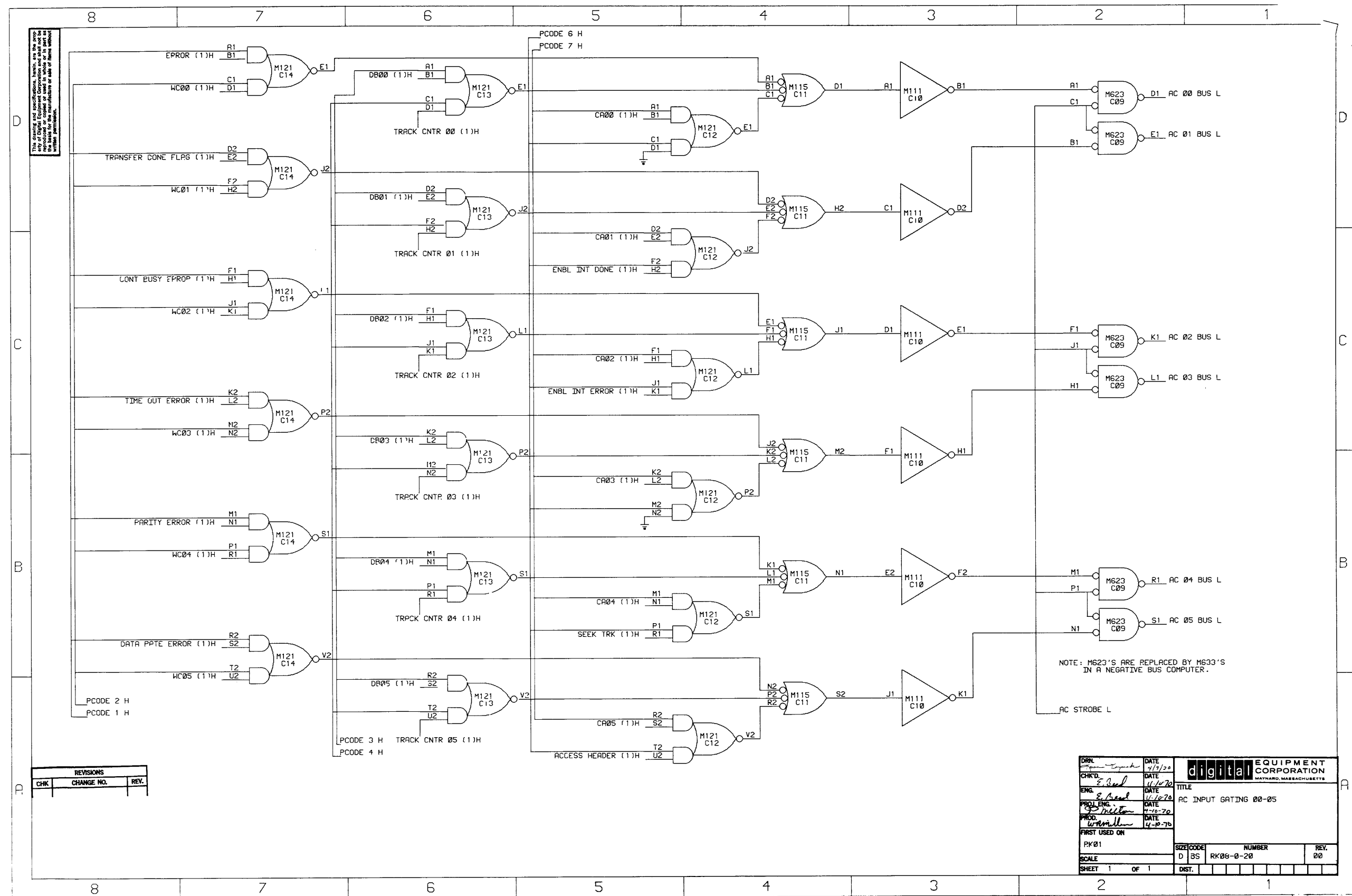

Figure II-32 AC Input Gating 00-05 Block Schematic Diagram

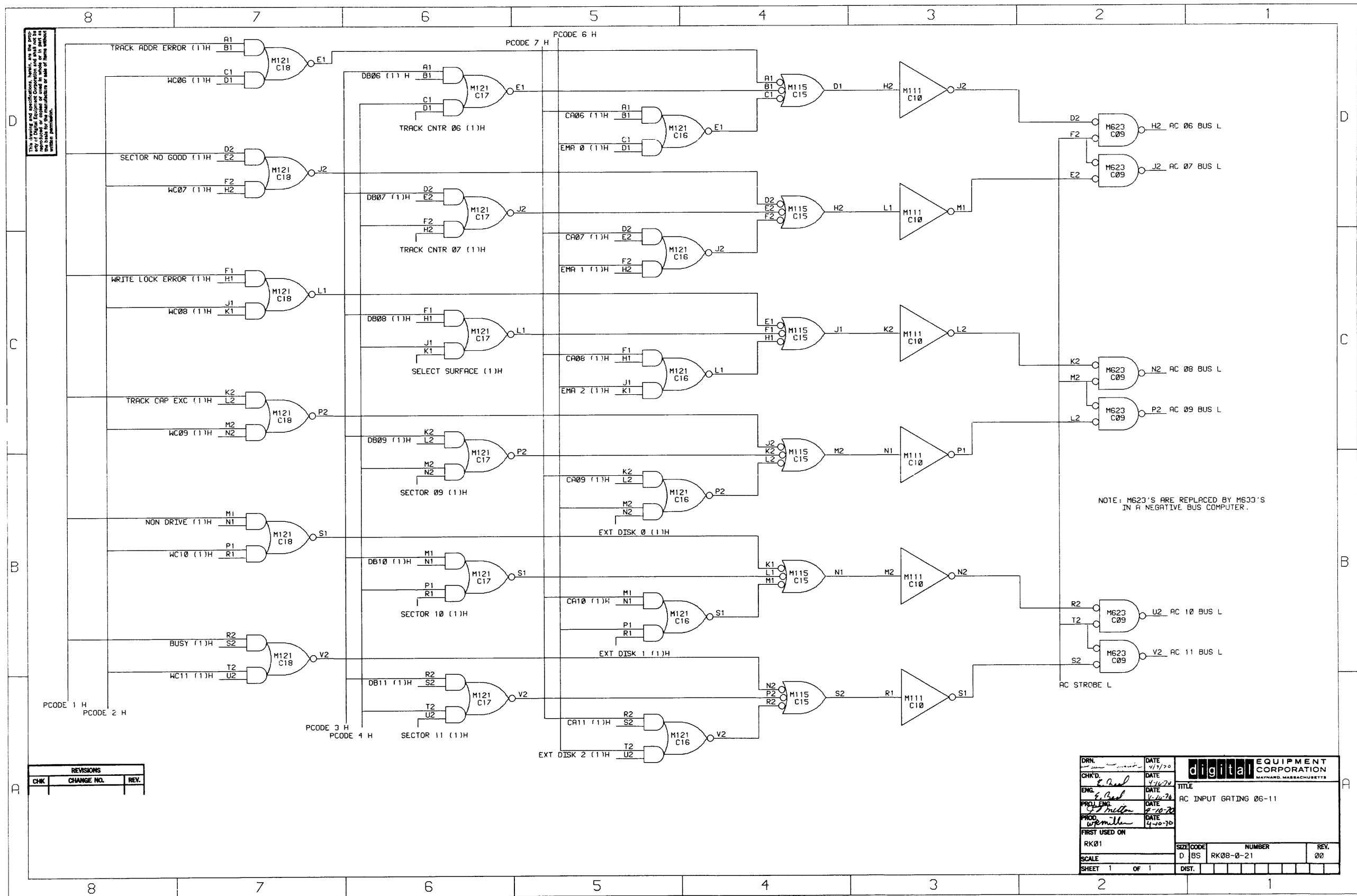

Figure II-33 AC Input Gating 06-11 Block Schematic Diagram

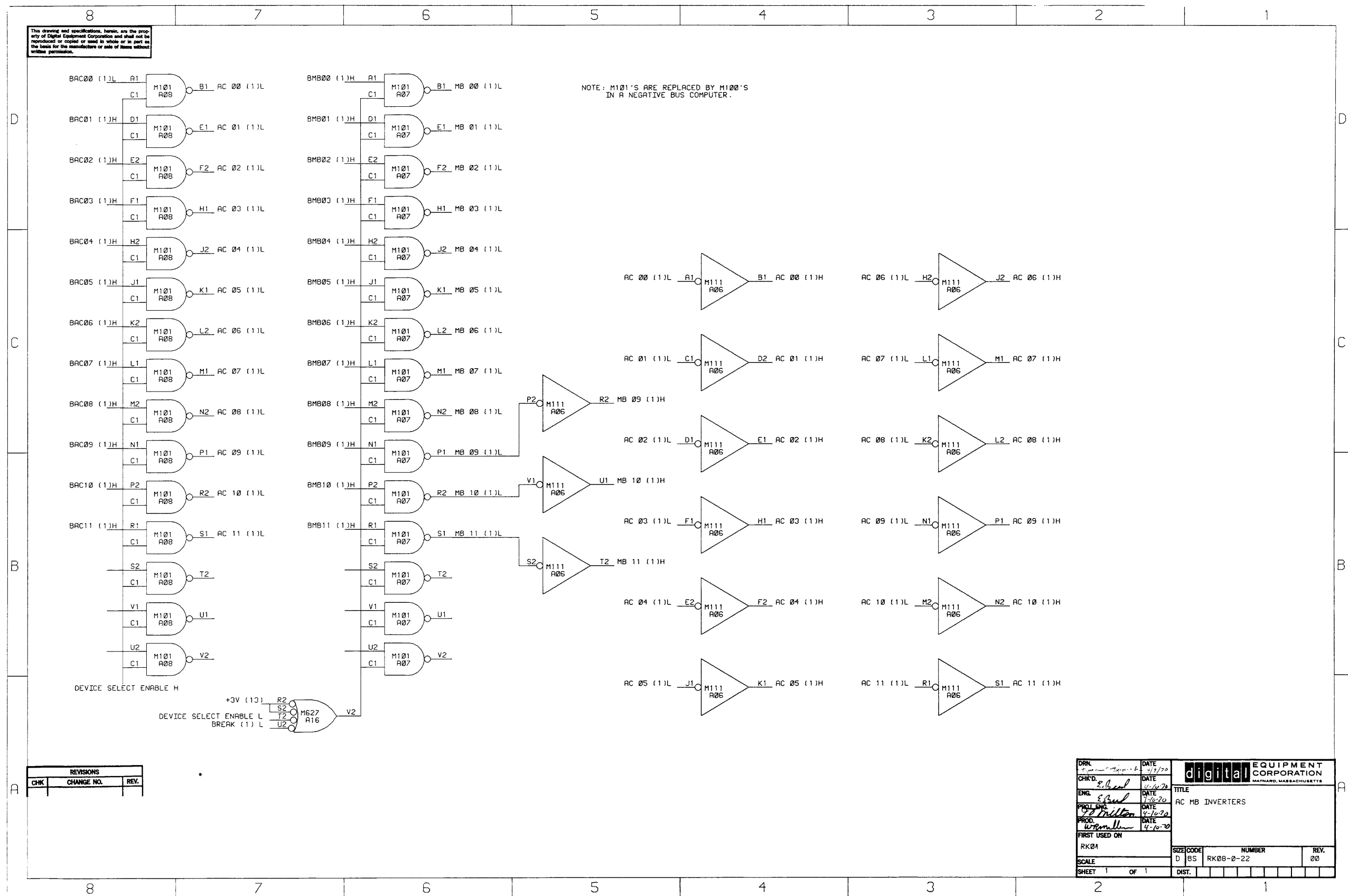
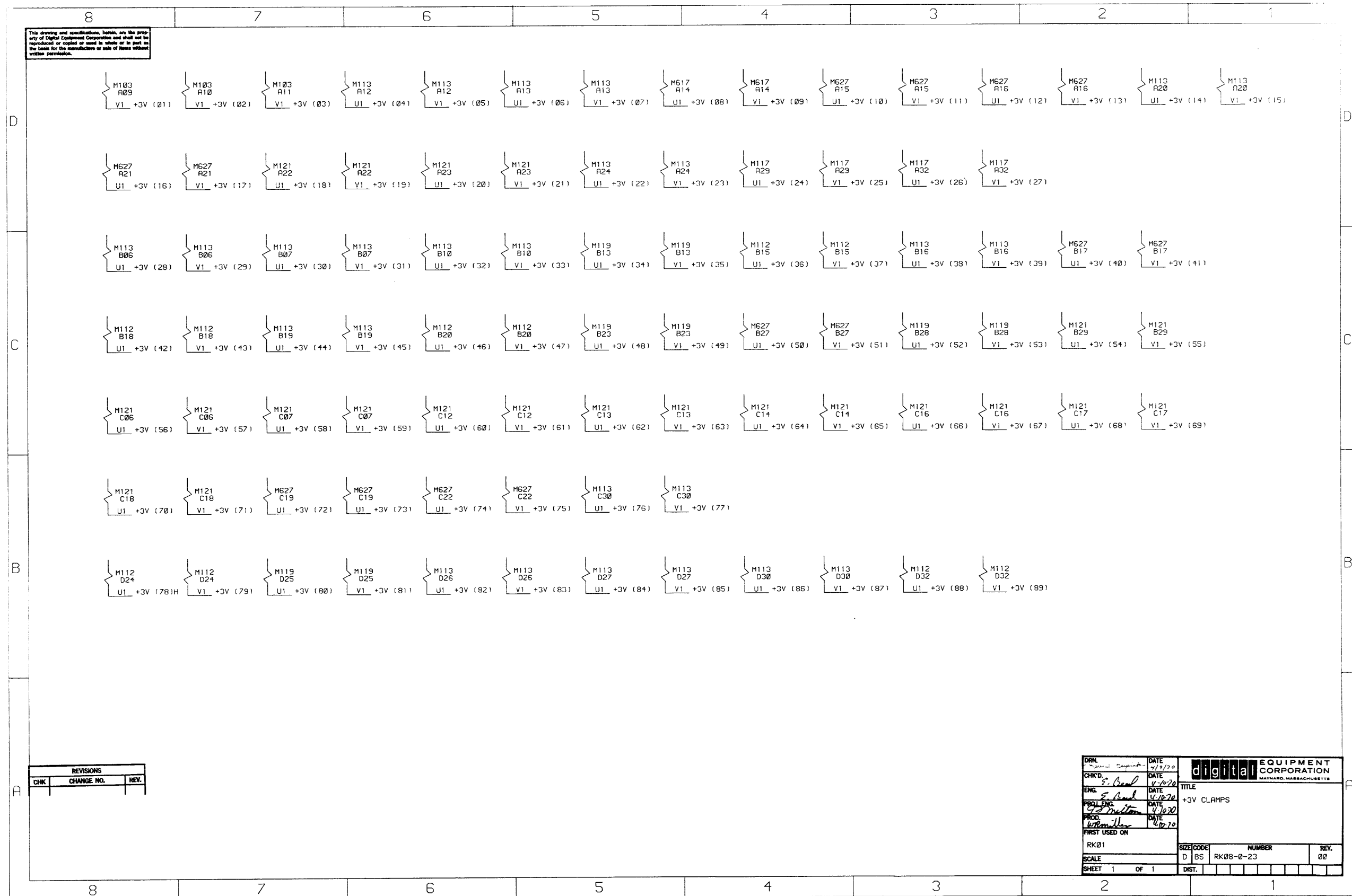

Figure II-34 AC Memory Buffer (MB) Inverters Block Schematic Diagram



REVISIONS		
CHK	CHANGE NO.	REV.

DRAWN	DATE	digital EQUIPMENT CORPORATION MAYNARD, MASSACHUSETTS
CHKD.	DATE	
ENG.	DATE	
PROL. ENG.	DATE	
PROD.	DATE	
FIRST USED ON		TITLE
RK01		+3V CLAMPS
SCALE	SIZE CODE	NUMBER
SHEET 1 OF 1	DIST.	REV. 0/0

Figure II-35 +3V Clamps Block Schematic Diagram

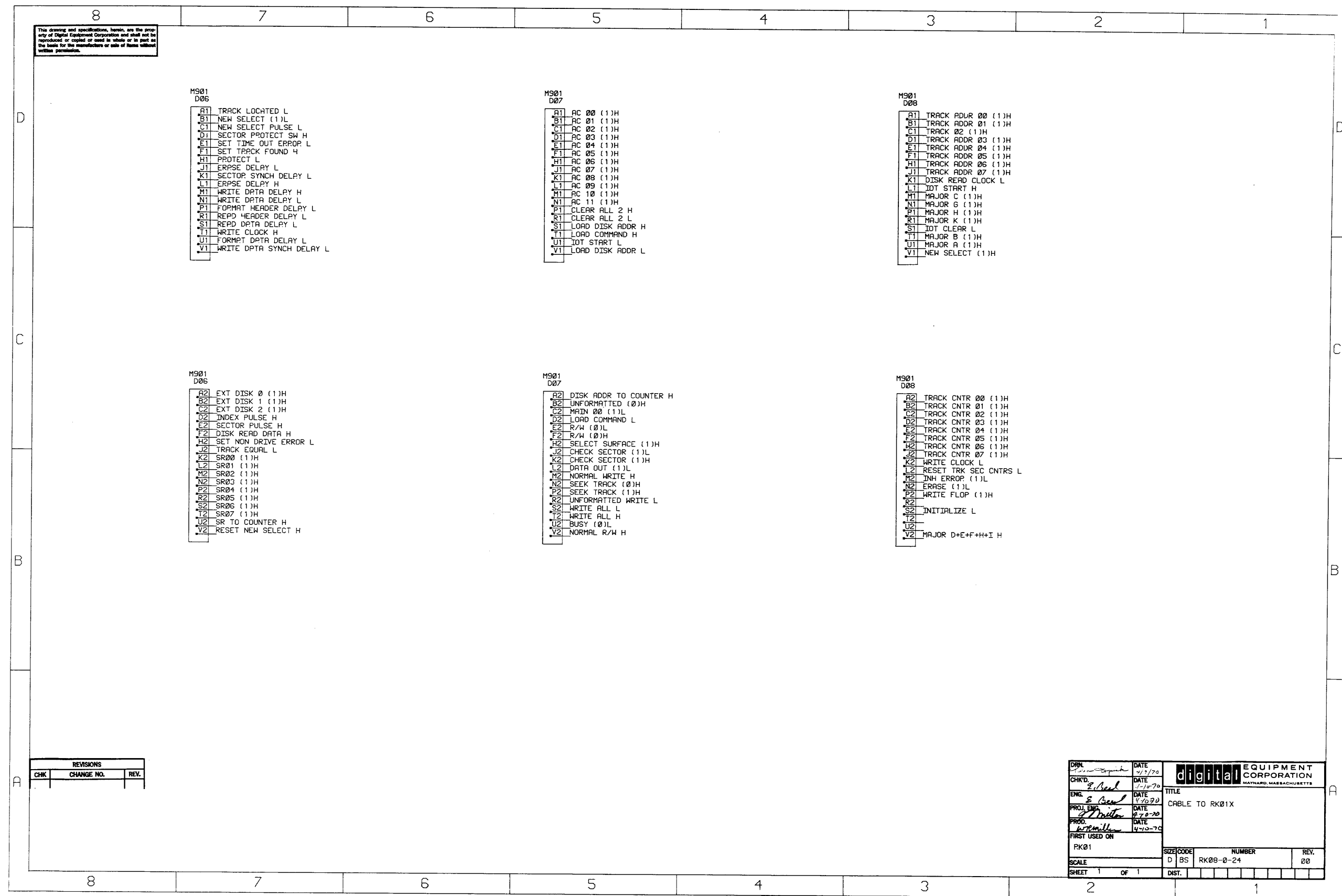

Figure II-36 Cable to RK01-X Block Schematic Diagram

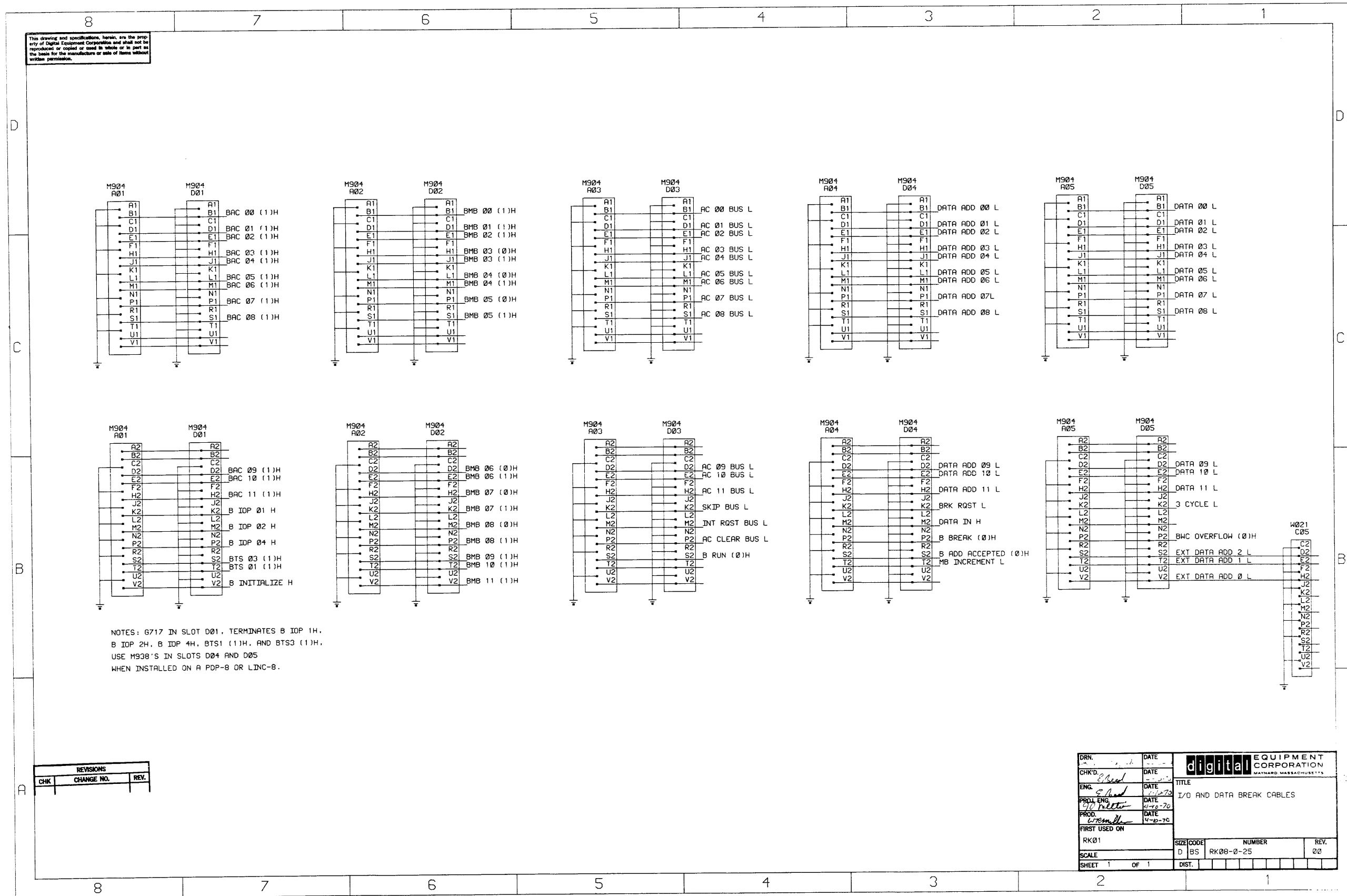

Figure II-37 I/O and Data Break Cables Block Schematic Diagram

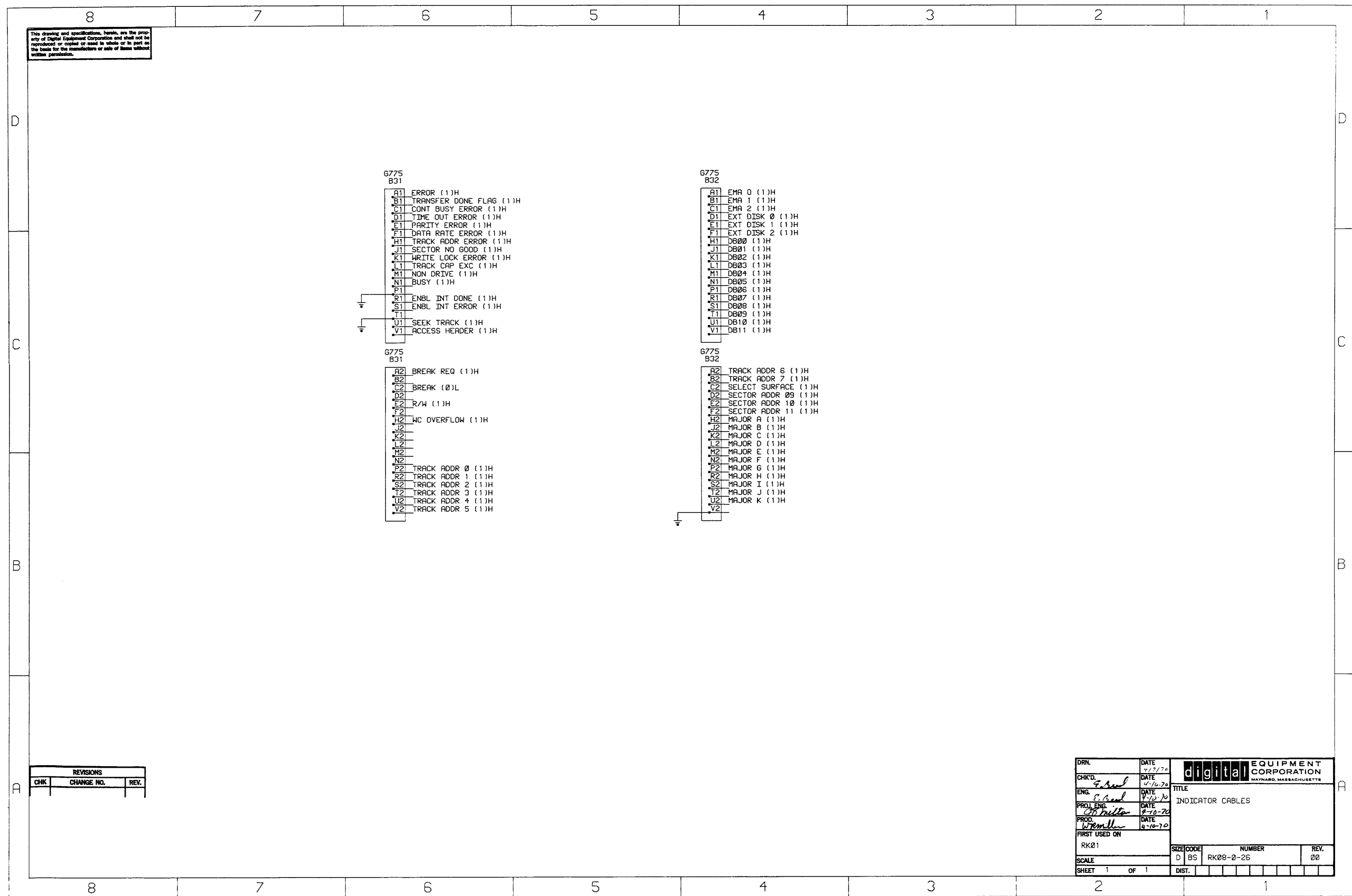

Figure II-38 Indicator Cables Block Schematic Diagram

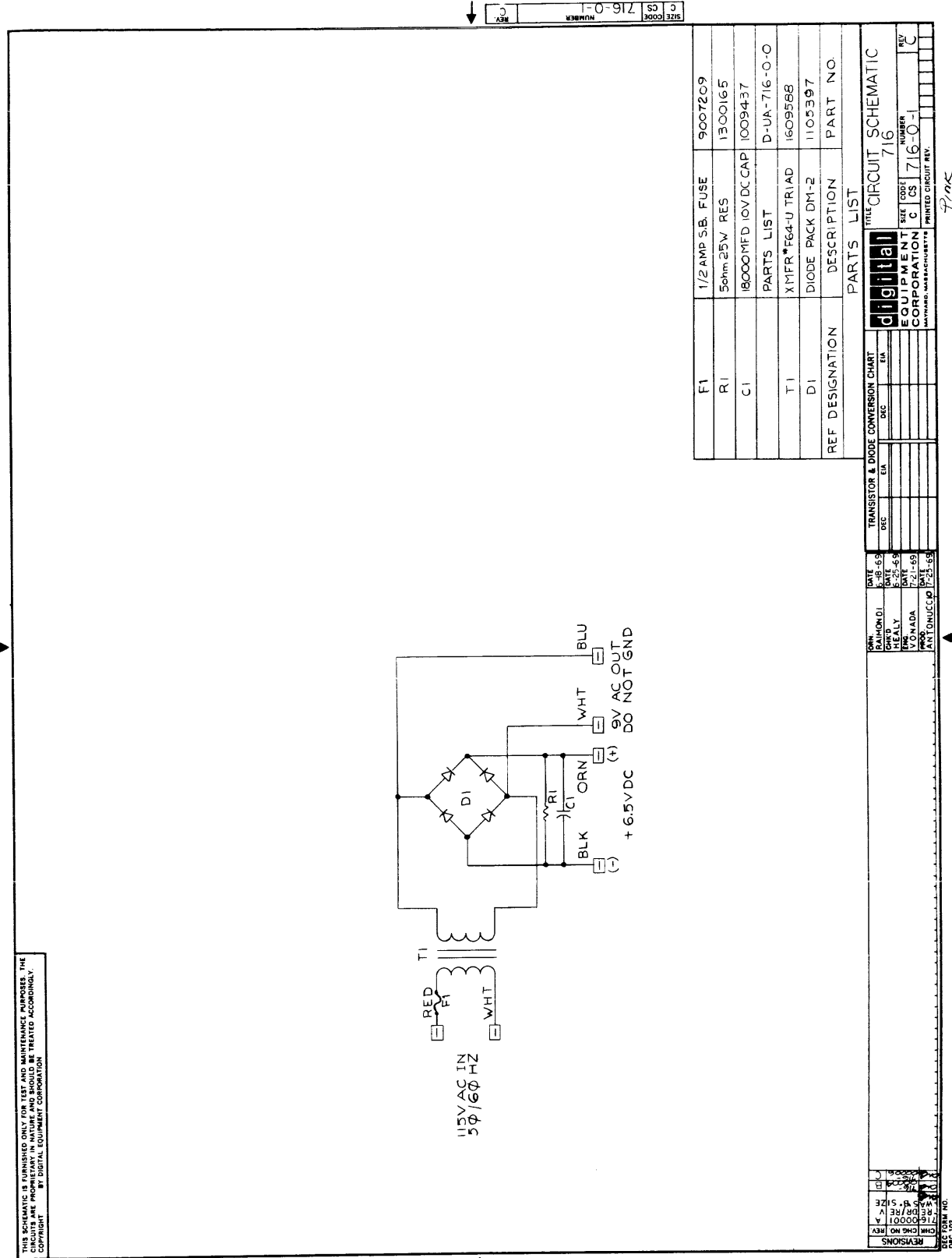

Figure II-39 Type 716 Power Supply Circuit Schematic Diagram

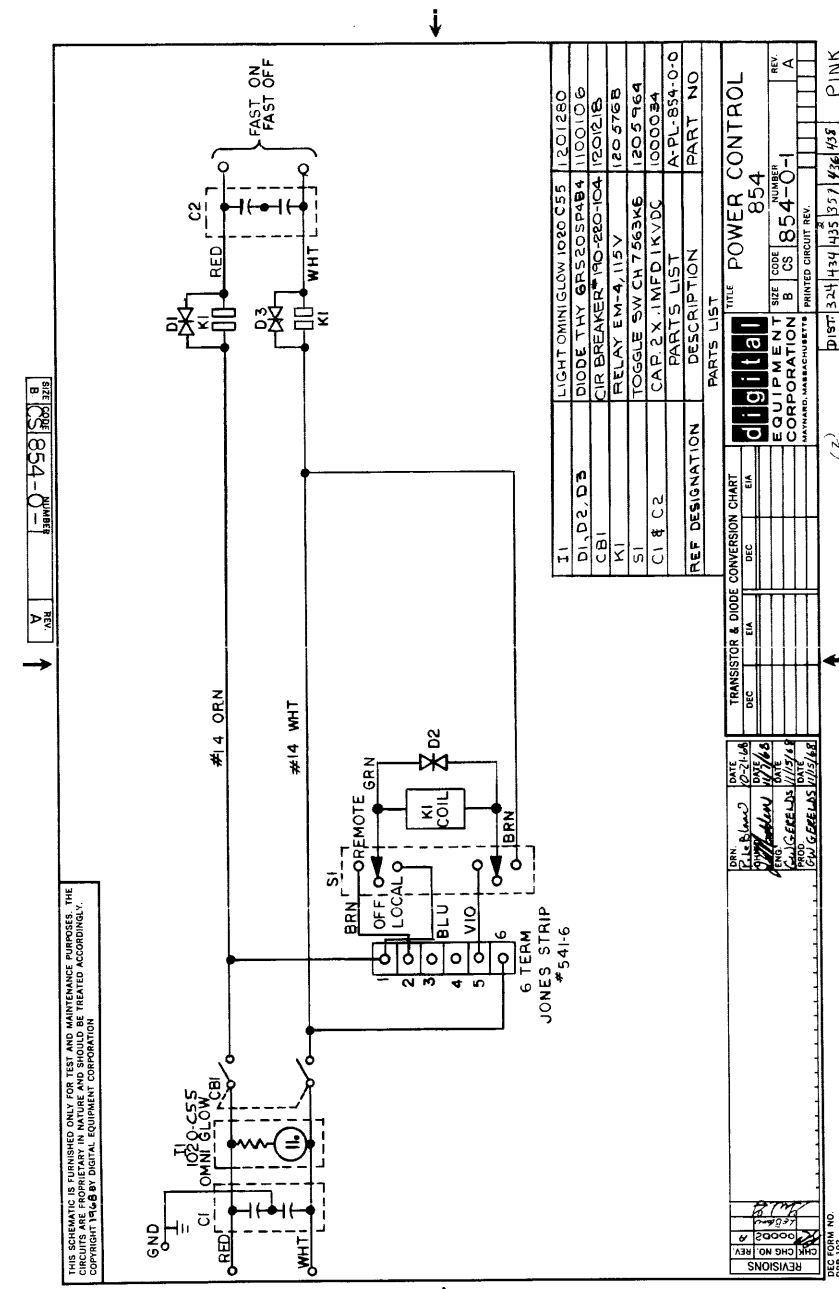

Figure II-40 Type 854 Power Control Panel Wiring Diagram

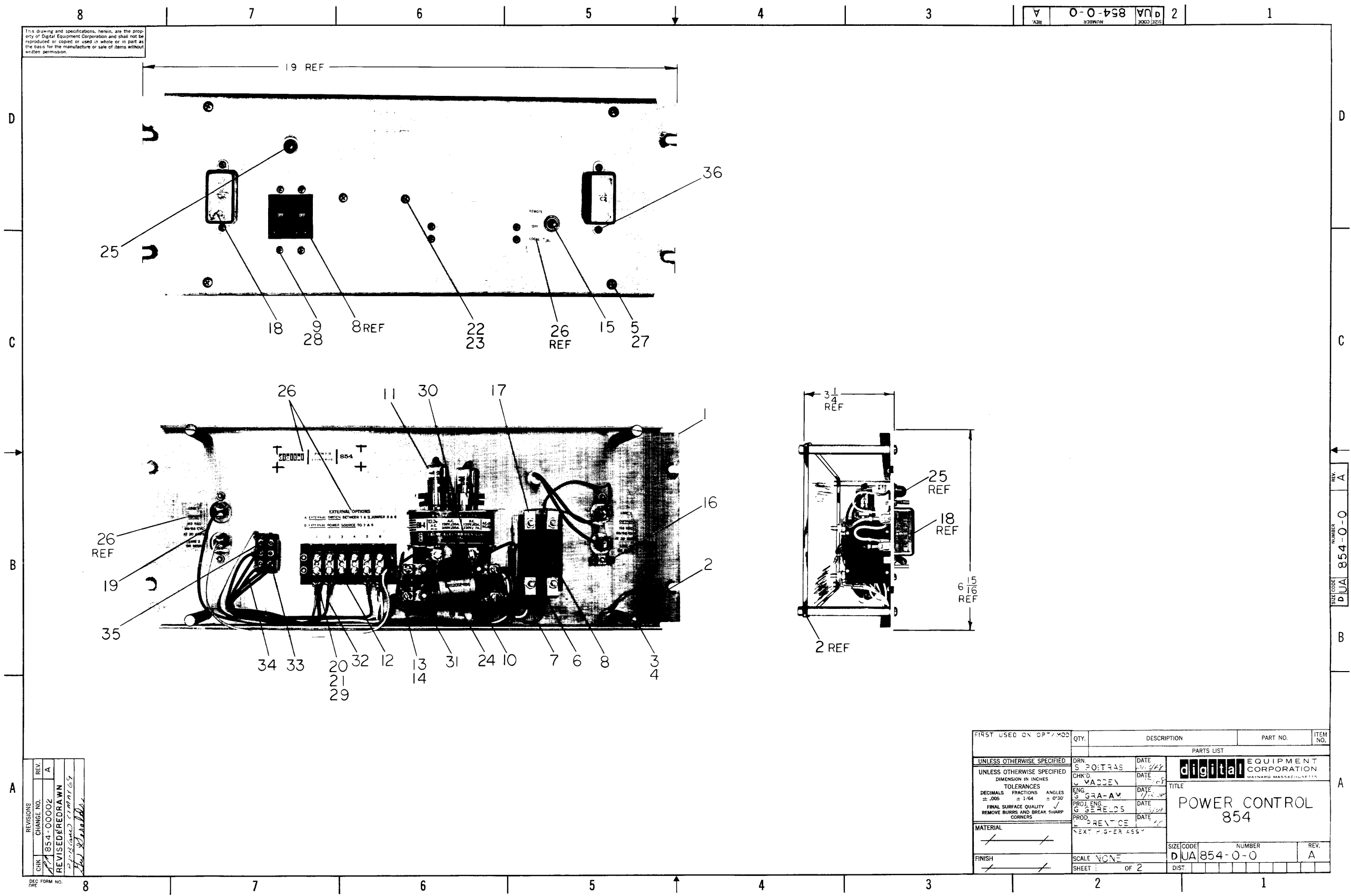

Figure II-41 Type 854 Power Control Panel
Component Pin Location Diagram
(Sheet 1)

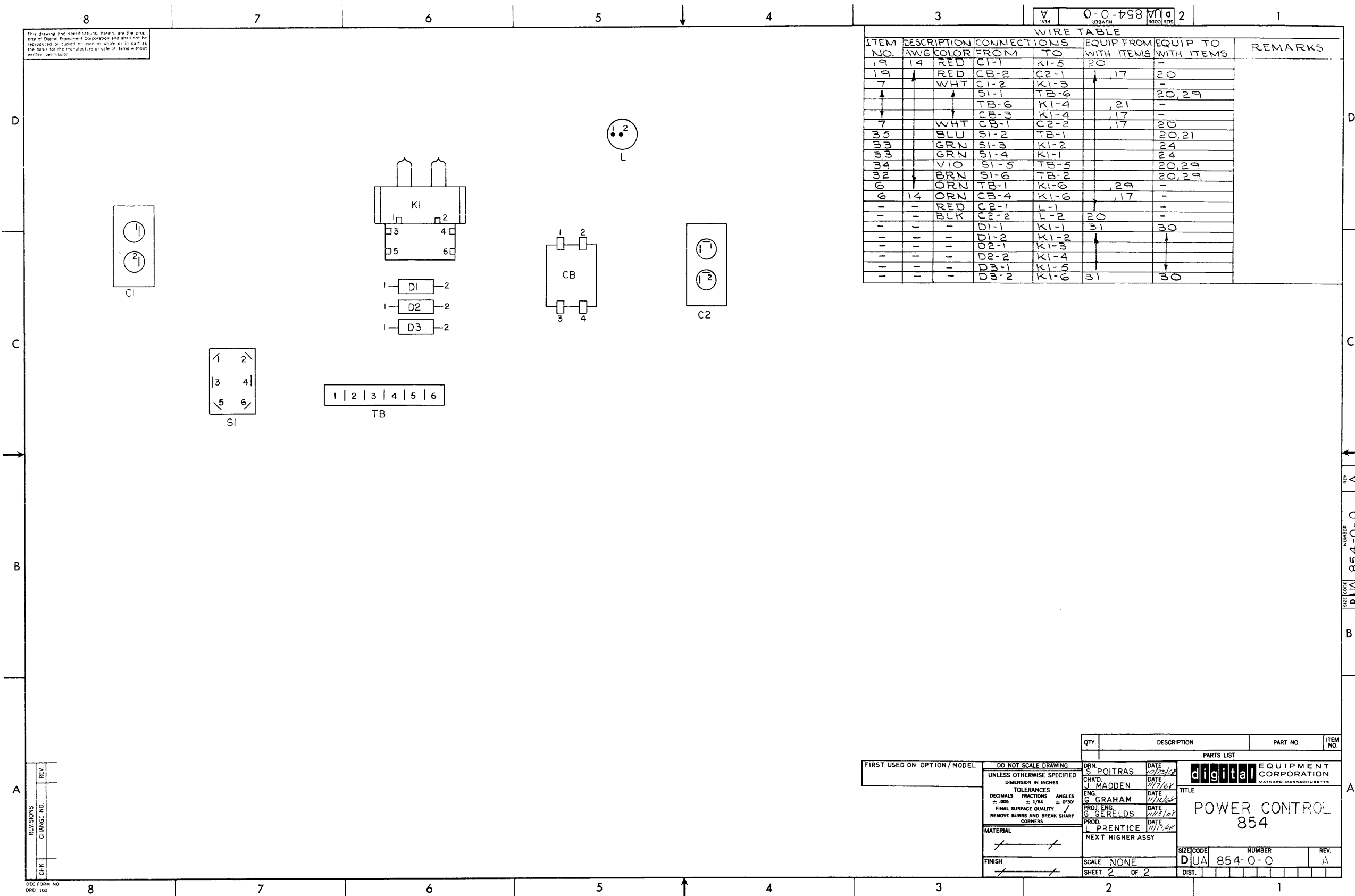

Figure II-41 Type 854 Power Control Panel
Component Pin Location Diagram
(Sheet 2)

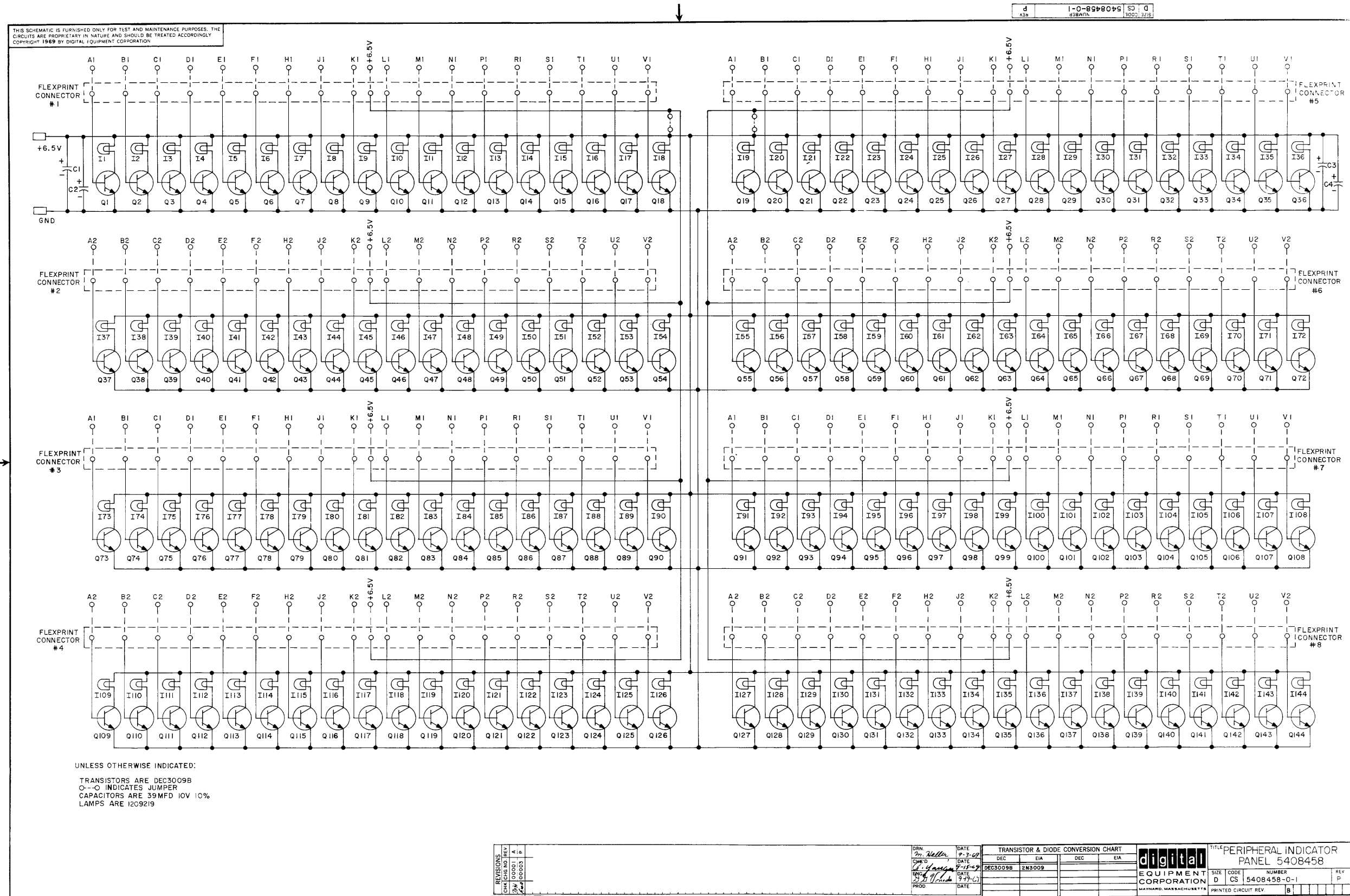
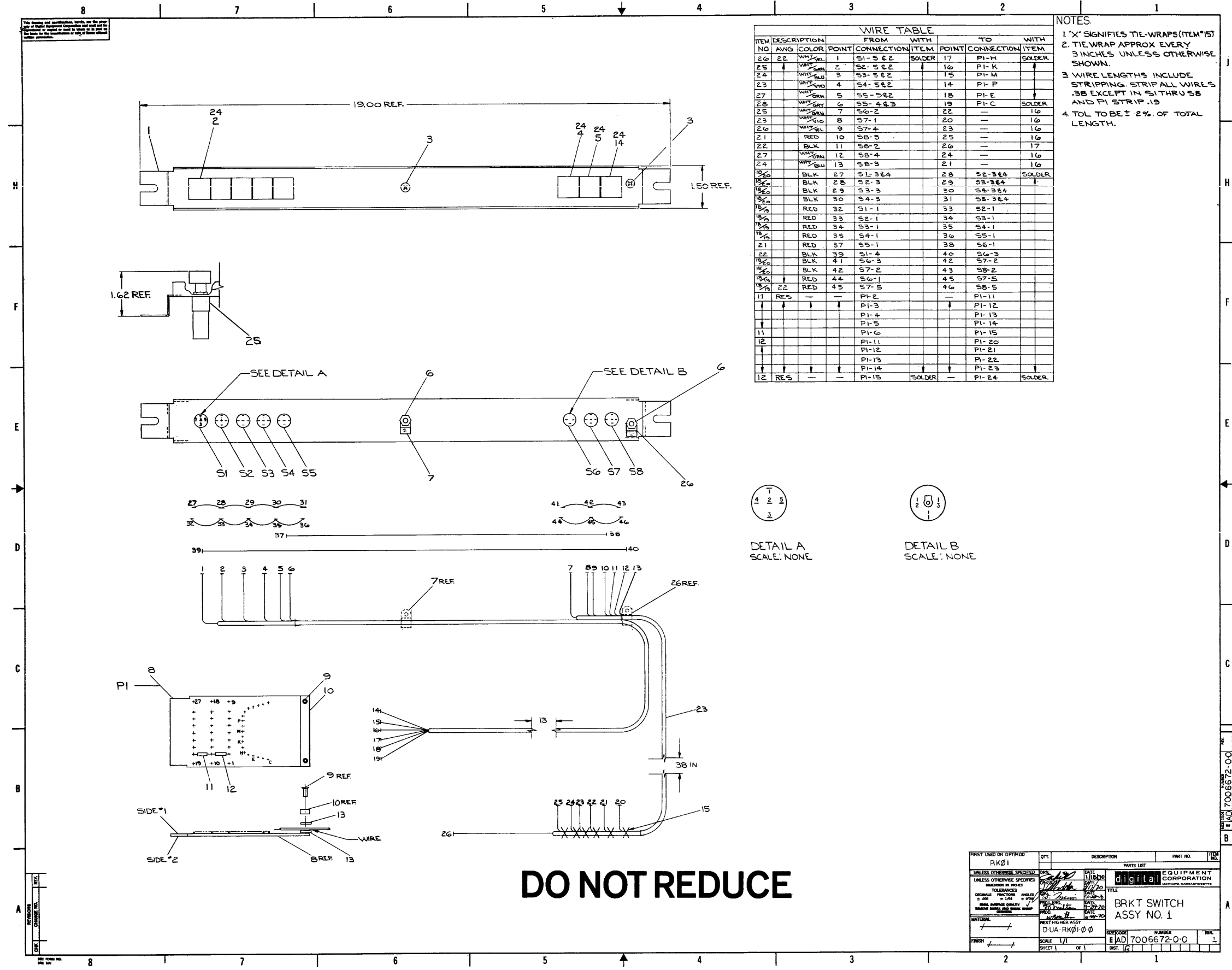
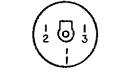

Figure II-42 Register Indicator Panel Circuit Schematic Diagram



ITEM NO.	AVG	COLOR	FROM		WITH	TO		WITH
			POINT	CONNECTION		POINT	CONNECTION	
26	22	WHY	1	S1-S E2	SOLDER	17	PI-H	SOLDER
25		WHY	2	S2-S E2		16	PI-K	
24		WHY	3	S3-S E2		15	PI-M	
23		WHY	4	S4-S E2		14	PI-P	
27		WHY	5	S5-S E2		18	PI-E	
28		WHY	6	S5-4 E3		19	PI-C	SOLDER
25		WHY	7	S6-2		22		16
23		WHY	8	S7-1		20		16
26		WHY	9	S7-4		23		16
21		RED	10	S8-5		25		16
22		BLK	11	S8-2		26		17
27		WHY	12	S8-4		24		16
24		WHY	13	S8-3		21		16
15		BLK	27	S1-3 E4		28	S2-3 E4	SOLDER
15		BLK	28	S2-3		29	S3-3 E4	
15		BLK	29	S3-3		30	S4-3 E4	
15		BLK	30	S4-3		31	S5-3 E4	
15		RED	32	S1-1		33	S2-1	
15		RED	33	S2-1		34	S3-1	
15		RED	34	S3-1		35	S4-1	
15		RED	35	S4-1		36	S5-1	
21		RED	37	S5-1		38	S6-1	
22		BLK	39	S1-4		40	S6-3	
15		BLK	41	S6-3		42	S7-2	
15		BLK	42	S7-2		43	S8-2	
15		RED	44	S6-1		45	S7-5	
15		RED	45	S7-5		46	S8-5	
11	RES			PI-2			PI-11	
				PI-3			PI-12	
				PI-4			PI-13	
				PI-5			PI-14	
				PI-6			PI-15	
11				PI-11			PI-20	
12				PI-12			PI-21	
				PI-13			PI-22	
				PI-14			PI-23	
12	RES			PI-15	SOLDER		PI-24	SOLDER

- NOTES:
1. 'X' SIGNIFIES TIE-WRAPS (ITEM #15)
 2. TIE WRAP APPROX EVERY 3 INCHES UNLESS OTHERWISE SHOWN.
 3. WIRE LENGTHS INCLUDE STRIPPING. STRIP ALL WIRES .38 EXCEPT IN S1 THRU S8 AND P1 STRIP .15
 4. TOL TO BE ± 2% OF TOTAL LENGTH.



DO NOT REDUCE

FIRST USED ON OPTIMOD	QTY.	DESCRIPTION	PART NO.	FILE
RK01				
UNLESS OTHERWISE SPECIFIED	DATE	PARTS LIST		
UNLESS OTHERWISE SPECIFIED	11/18/70	digital EQUIPMENT CORPORATION		
TOLERANCES	DATE	TITLE		
DECIMAL FRACTIONS ANGLES	11/18/70	BRKT SWITCH ASSY NO. 1		
± .01 ± .005		DRAWN BY: [Signature]		
± .001 ± .0005		CHECKED BY: [Signature]		
± .0001 ± .00005		DATE: 11-18-70		
		SCALE: 1/1		
		SHEET 1 OF 1		
		DST: 16		

Figure II-43 Control Panel Switch Assembly Diagram

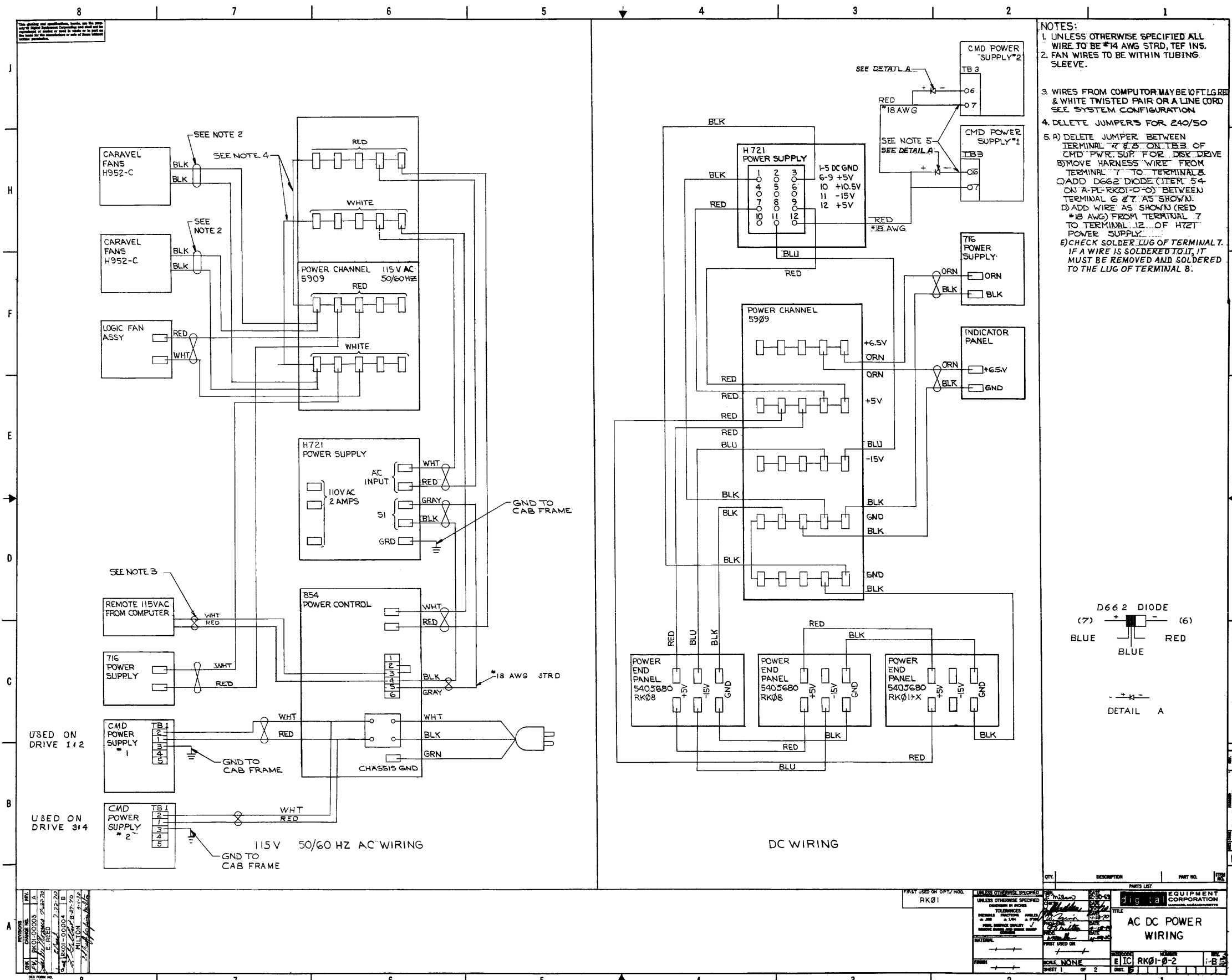
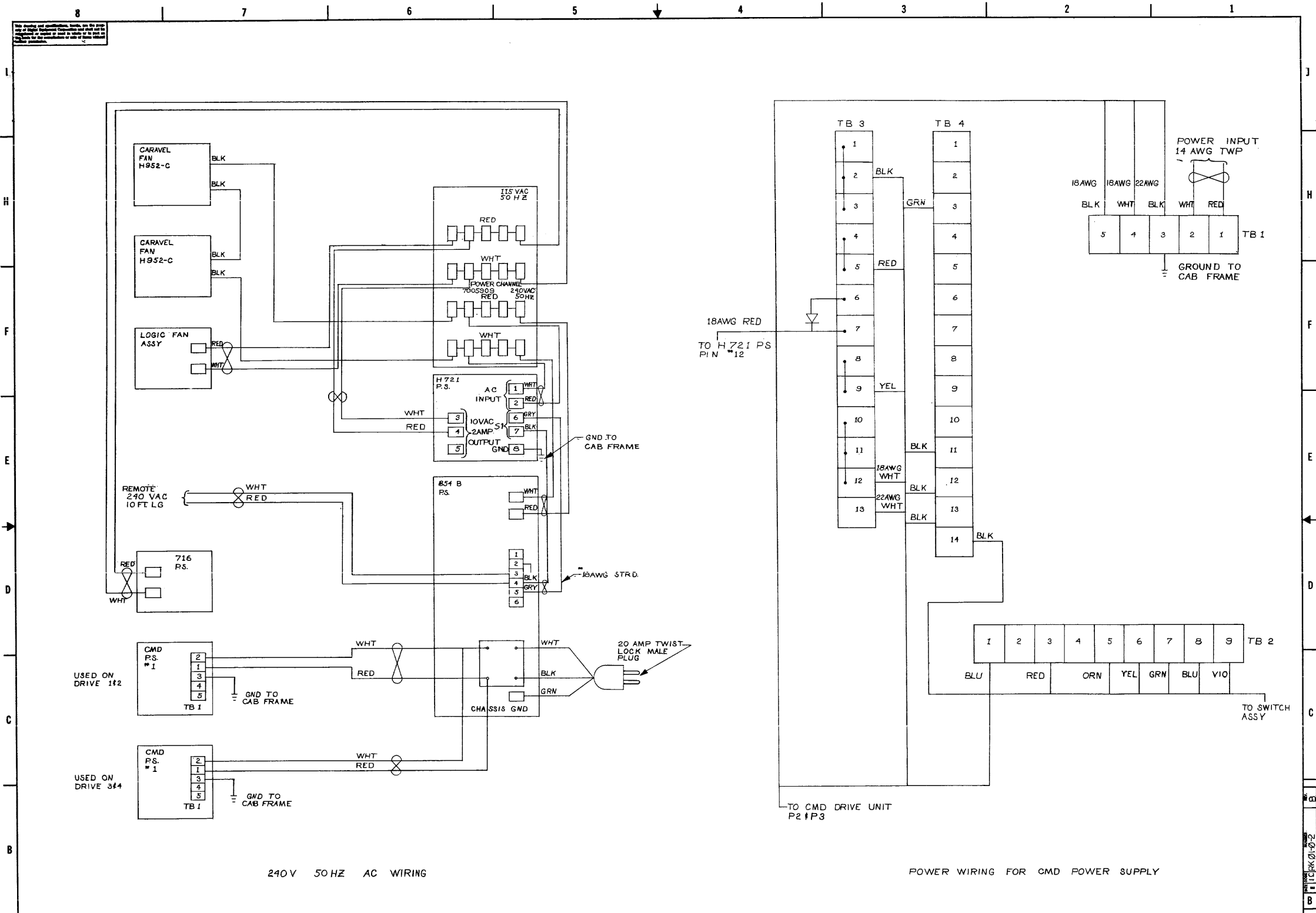

Figure II-44 AC/DC Power Wiring Diagram



UNLESS OTHERWISE SPECIFIED		QTY.	DESCRIPTION	PART NO.	ITER.
DRG	MILAN		DATE	EQUIPMENT CORPORATION	
CHKD	RADDEN		DATE	DIGITAL	
APP'D	MINOR		DATE	TITLE	
DESIGNED BY	PROJ. ENGR.		DATE	AC DC POWER WIRING	
DRAWN BY	PROJ. MGR.		DATE	ELECTRICAL	
CHECKED BY	PROD. MGR.		DATE	MILLER	
MATERIAL	FIRST USED ON			REVISION	
FINISH	SCALE			ELECTRICAL	
	SHEET	2	OF	2	B