

PROJECT NO. 185

TITLE:

AN-1 DIAGNOSTIC TEST ROUTINE

EQUIPMENT AFFECTED: G-15, AN-1

APPLICATION SECTION

PREPARED BY: A. J. Record

CHECKED BY: N. Love

APPROVED BY: N. Love

DATE: November 1, 1962

SUM CHECK LIST

.147x 86W	Number track
-.524UW52	Loader & Selector
-.WU60851	Comparator
-.3VY01V4	Tests 1, 2, 3, 4, 5 & 7
.UZXZWZ4	Tests 6, 8, 9, 10
.2VW530W	Test 1 Data
.Z00V3V4	Test 2 Data
-.71079XW	Test 3 Data
-.2839Z6W	Test 4, 5, 6 punch data, also Test 4 check and comparison data
.X5V6Z2Y	Test 5 check and comparison data.
.WY9WY89	Test 6 check and comparison data.

SECTION X

APPENDIX

TEST SPECIFICATIONS AND SCHEMATICS

AN-1 Test Routine, No. 2	7 pages
AN-1 Loader and Selector	4 pages
AN-1 Comparator	4 pages
AN-1 Basic Routines, No 1, 2, 3, 4, 5, & 7	5 pages
AN-1 Test, No. 6, 8, 9, & 10	5 pages

Figure

24	AN-1 Logic -1, Schematic 3D497
25	AN-1 Logic -2, Schematic 3D496
26	HSPR Coupler, Schematic 3E891

The AN-1 test magazine contains ten tests all stored within the memory of the G-15. All necessary data and factors are also stored in the memory of the G-15. Any one test may be selected at any time. The selector routine automatically selects the proper test and data. Below is a list of the routines and a number associated with it. By selecting the selector routine (SCF-GO) then type in the number associated with the routine desired, the routine is transferred from its storage place into Line one, where all routines are executed. The selector is stored in Line zero and may be selected as noted above (SCF-GO).

<u>Routine No</u>	<u>Name</u>
1	Punch Resonance Test (punches only)
2	Zig-Zag Test (punches only)
3	Mode 1 Short
4	Mode 1 Long
5	Mode 2 Long
6	Mode 3 Long
7	5 Level Test
8	Type-in Mode 1
9	Punch Leader
10	Punch Leader

Below is a list showing the block number on the tape.

<u>Block</u>	<u>Name</u>	<u>G-15 Storage</u>
00	Number Track	NT
01	Loader & Selector	00
02	Comparator	03
03	Tests 1, 2, 3, 4, 5, 7	04
04	Tests 6, 8, 9, 10	05
05	Test 1 Data	06
06	Test 2 Data	07
07	Test 3 Data	08
08	Test 4, 5, 6 Punch Data	09
09	Test 5 check and Comparison Data	10
10	Test 6 check and Comparison Data	11

Example: If on initial read-in of the magazine it is desired to select Test 3, type a 3 tab (S). (On initial read-in, the selector is automatically selected and input gated.) Upon typing (S) in the selector, in this case, would move line 4 to line 1 and exit to line 1 for execution of the test. All tests begin at work time zero, therefore, SC1-F will start any routine over that has already been selected and moved to Line one for execution. If at this time it is desired to select another test routine, say Test 1, type SCF-GO, when input is gated type 1 tab (S) and the routine will be moved from storage to the execution line and executed.

TEST 1 - PUNCH RESONANCE TEST

This is strictly a punch test. It does not read any tape. It is as near as possible a duplication of Teletype's resonance test. It checks the punch for resonant vibrations. Only by eye can an error be detected or by comparing the tape punched with a known good tape. It should punch the following sequence:

ZZ ZZ ZZ ZZ 55 UU 55 UU 55 UU 00 00 00 00 ZZ ZZ ZZ 00 00 00

Since a Reload or Stop code is punched it can disrupt this sequence. Therefore, the reload and stop switches should be set at all zeros. The position of the mode selector switch is arbitrary and the Blank Frame Switch should be in the "punch" position. Under normal checkout conditions, it would not be necessary to run this test.

TEST 2 - ZIG ZAG TEST

This is strictly a punch test. It does not read any tape. An error is detected by eye, or by comparison with a known good tape. This test punches a zig-zag pattern of 3 characters beginning with a ZZ and ending with a ZZ. A reload or stop will follow each zig-zag. This pattern is:

ZZ 07 OY 1W 38 70 YO 70 38 1W OY 07 ZZ 00 Reload or stop.

This test is designed to present a recognizable pattern which will not necessitate the use of the HSR-8. The switch settings should be as described in Test 1.

TEST 3 - MODE 1 SHORT

This test will punch and read. It will punch a short block of 14, 8 bit characters and a stop code. Then will read this short block back into the G-15 through the AN-1 logic and check sum this information. If no

TEST 3 - Continued

error is found, the bell will ring and test will be repeated. If an error is detected, the routine branches to a comparator routine and will type out the right and then the wrong information in a 28 digit format followed by 3 tabs, a carriage return and end. The test will then be repeated.

The punch and read sections of the routine may each be looped by putting the punch switch on. The punch motor switch on the G-15 should be turned off. Two break points are provided, one at the beginning of the punch section and the other at the beginning of the read section. Therefore, by breakpointing to the right point in the routine and putting on the punch switch that part of the routine will be looped.

Switch settings should be as follows:

Stop - 1 1 0 0 0 0 0 0
Reload - 0 1 0 0 0 0 0 0

The Mode Selector Switch should be in Mode 1. The Flex-HSR switch must be in the HSR position at all times. The Control Tape switch should be in Neutral and the 100-20 switch should be in the 100 position.

This test eliminates all reload logic.

TEST 4 - Mode 1 Long

Test 4 is the same as Test 3 except that the block of information punched and read is much longer. There are sixteen groups of fourteen characters. Each group is followed by a reload except the last one and then a stop code is punched. The possibility of looping the punch and read sections of this test is the same as Test 3. A bell rings if no error has been detected. A timeout occurs if an error is detected with the same format as Test 3. Just the 0 mod 4 four-word group where the error is will be typed out. If the only error that occurred was in what would normally be word 38, only the 0 mod 4 four-word group beginning at word 36 will be typed out.

TEST 4 - Continued

Type-out Example:

.36 (0 Mod 4 Word)

.XXXXXXXXXXXXXXXXXXXXXXXXXXXXXXXX (right)

.XXXXXXXXXXXXXXXXXXXXXXXXXXXXXXXX (wrong)

All switch settings are the same as Test 3. This test uses all of the mode 1 logic.

Test 5 - Mode 2 Long

This test punches the identical information of Test 4. Since mode 2 supplies its own reloads for reading, the reloads on the tape will be interpreted as a character. This test is set up to reload every 10th character. The AN-1 should reload 23 times and stop on the 24th. The stop code on the tape will stop the computer. Looping and error type-out are the same as Test 3 and 4. The information will be different.

The Mode Selector switch should be in "Mode 2". The counter switches should be set for 10 (ten). All other settings remain the same as described in Test 3.

This test will use all of the mode 2 logic.

TEST 6 - MODE 3 LONG

This test punches the identical information in Test 4. Since mode 3 supplies its own stop codes on read-in, the reload and stop codes on the tape will be interpreted as a character. This test is set up to stop every 10th character. The AN-1 should supply 24 stop codes. Looping and error type-out format is the same as Tests 3 and 4. The information typed will be different.

The Mode Selector switch should be in "Mode 3". All other switch settings should be as described in Test 5.

This test will use all of the AN-1 output logic.

TEST 7 - 5 LEVEL TEST

This is another punch-read test. The information punched and read is the number track of the G-15. It is punched in standard 5 level form, then read back into the G-15 through the AN-1 and checked summed. If no error is detected, the bell rings. If an error is detected, the right and wrong information is typed out in a 29 digit format.

There is no provisions for looping any part of this test. Switch settings have no control over this test. A very minimum amount of AN-1 logic is used in standard G-15 output. No AN-1 timing is involved, only the control section.

TEST 8 - TYPE-IN MODE 1

This test provides for typing into line 19 information, up to 108 words, that is to be punched out on tape and read back as in test 4. The information typed in must be of the form of 28 hexadecimal characters and a hex zero followed by a reload on the typewriter. No tabs necessary. When the last information is typed, type reload and (S). The routine is automatic from there on.

Switch settings should be as described in Test 3.

TEST 9 - PUNCH LEADER (COMPLETELY VARIABLE)

This test will punch blank leader by command. Upon selecting this test, type in will be gated. Any hex number from one to seven digits may be entered and followed by tab S . The size of this number will determine the length of blank leader to be punched. Each unit of the number typed in will cause approximately 3 blank frames to be punched.

The blank leader punched will be followed by a short block of data which indicates completion of the punch leader routine.

All switch settings may be as described in Test 3. The position of the blank frame switch is arbitrary since the leader will be punched by command.

TEST 10 - PUNCH LEADER

This test will also punch blank leader by command. In the case of test 10, the leader length is determined by the location of a bit in some OMod4 word in line 19. The number typed in must equal some OMod4 word in hex. The leader length will always be multiplies of 1.4 in. Line 19 will always be precessed until it finds the marker in some OMod4 word, at which time a short block of data will be punched and the routine repeats. If it is desired to punch 3 x 1.4 in. or 4.2 in. of blank leader, a marker should be in the third OMod 4 group from the end of line 19. This would be word 96 or 60 tab S should be entered.

All switch settings may be as described in Test 3. The position of the blank frame switch is arbitrary since the leader will be punched by command.

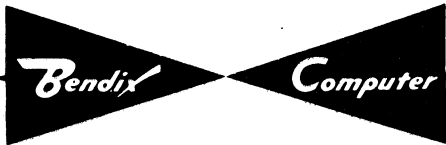

Los Angeles 45, California

Page 1 of 4

G-15 D
 PROGRAM PROBLEM: AN-1 Loader and Selector

Prepared by A. Record

Date: 8/28/61

Line 00

L	P	T or LK	N	C	S	D	SP	NOTES
00	U	01	01	0	19	00		M19→MO
01		03	02	0	21	31		Mark Exit To MO
02		03	04	0	00	28		First Command To AR
03	U	03	23	0	23	31		First Command
04		00	05	0	28	00		First Command To MO
05		06	07	0	00	20		Loader to 20.02
06	U	22	20	0	19	02		Line Loader
07		09	08	0	15	31		Read Tape
08		10	08	0	23	31		Test Ready
09	W	10	11	0	00	28		Command 1 To AR
10	U	00	13	0	19	27	-	Command 1
11		13	U3	0	31	31		NC AR See 10
13		15	15	0	08	31		Type AR
14		02	16	0	20	28		Line Loader To AR
15	W	U0	09	0	00	31		Set Ready
16		17	13	1	00	29		Add 1 To Dest.
17		(0000001)				Dest. = 1
18		02	19	0	28	20		Store AR
19		21	21	0	31	31		NC AR See 06 & 16
20		21	22	3	00	29		Sub. D = XX
21	U	22	20	0	19	11		D = XX
22		23	23	0	28	27		Is Loading Complete?
23	U	30	30	0	00	20		Yes Start Load 19 Format
24	U	27	25	0	23	31		No Clear PG
25	U	26	07	0	25	19		Clear Line 19

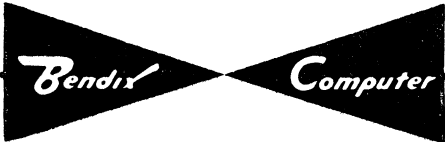

Los Angeles 45, California

Page 2 of 4
 Date: 8/28/61
 Line 00

G-15 D
 PROGRAM PROBLEM: AN-1 Loader and Selector

Prepared by A. Record

L	P	T or LK	N	C	S	D	BP	NOTES
26	(0000000)					
27	(6000000)					19 Format
28	(XY2200C)					
29	(0000000)					
30		00	31	4	20	02		
31		02	32	4	20	02		
32		33	34	0	00	28		
33	(1W011400)					AR Format
34		03	35	0	28	03		
35	U	40	36	0	25	23		Clear Line 23
36		38	37	0	12	31		Set Input
37		39	37	0	28	31		Test Ready
38		00	39	0	23	24		Routine # to MQ
39		24	40	0	26	31		Shift 12 bits
40		41	42	0	00	28		Command 2 AR
41		46	49	0	28	28		Command 2
42		44	43	1	24	29		Add Routine No. to AR
43		45	45	0	31	31		NC AR See 41
U2	(0000000)					
U3	(6000000)					Special 5 level
U4	(0880000)					Format
U5	(0000000)					

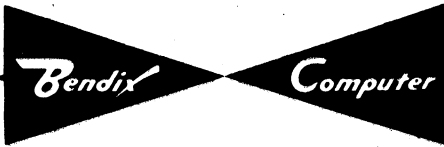

Los Angeles 45, California

Page 3 of 4

Prepared by A. Record

Date: 8/28/61

G-15 D
PROGRAM PROBLEM :

AN-1 Loader and Selector

Line 00

L	P	T or LK	N	C	S	D	BP	NOTES
50	U	51	70	0	04	01		Load Test No. 1 Resonance Test
70		72	00	1	21	31		
51	U	52	71	0	04	01		
71	U	73	73	0	00	28		Load Test No. 2 Zig Zag Test
72	U	03	03	0	23	31		
73		00	70	0	28	01		
52	U	53	74	0	04	01		
74	U	76	76	0	00	28		Load Test No. 3 Mode 1 Short
75	U	03	06	0	23	31		
76		00	70	0	28	01		
53	U	54	77	0	04	01		
77	U	79	79	0	00	28		Load Test No. 4 Mode 1 Long
78	U	03	31	0	23	31		
79		00	70	0	28	01		
54	U	55	80	0	04	01		
80		81	82	0	00	28		Load Test No. 5 Mode 2 Long
81	U	03	57	0	23	31		
82		00	70	0	28	01		

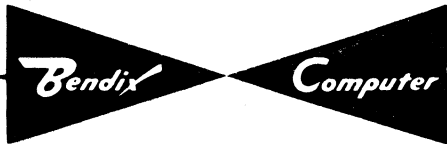

Los Angeles 45, California

Page 4 of 4

G-15 D

Prepared by _____

Date: _____

PROGRAM PROBLEM: AN-1 Loader and Selector

Line 00

L	P	T or LK	N	C	S	D	BP	NOTES
55	U	56	83	0	05	01		
83		84	85	0	00	28		Load Test 6 Mode 3 Long
84	U	03	01	0	23	31		
85		00	70	0	28	01		
56	U	57	86	0	04	01		
86		87	88	0	00	28		Load Test 7 Punch 5 level
87	U	03	81	0	23	31		
88		00	70	0	28	01		
57	U	58	89	0	05	01		
89		90	91	0	00	28		Load Test 8
90	U	03	31	0	23	31		
91		00	70	0	28	01		Type in
58	U	59	92	0	05	01		
92		93	94	0	00	28		Load Test 9
93	U	03	67	0	23	31		
94		00	70	0	28	01		
59	U	60	95	0	05	01		
95		96	97	0	00	28		Load Test 10
96	U	03	81	0	23	31		
97		00	70	0	28	01		

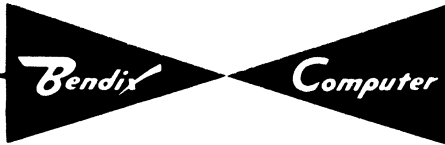

Los Angeles 45, California

Page 1 of 4

Prepared by A. Record

Date: 8/28/61

G-15 D
PROGRAM PROBLEM: Comparator AN-1

Line 03

L	P	T or LK	N	C	S	D	BP	NOTES
05	U	08	93	0	23	31		Clear PG
93		01	97	0	25	23		Clear 23.01
97		97	97	0	28	31		Test Ready
98		00	09	6	23	24		Clear AR $AABB \times 2^{-28} \rightarrow MQ_1$
09		24	34	0	26	31		$MQ_1 = AABB \times 2^{-16}$ shift
34		35	36	0	29	22		Clear Dummy A Clear 22.03
36		38	41	6	03	25		$10 \times 2^{-19} \rightarrow ID_1$
38		(0001400)						
41		08	50	0	24	31		Multiply x 10's in AA or BB
50		53	57	1	03	25		$1 \times 10^{-19} \rightarrow ID_1$
53		(0000200)						
57		08	68	0	24	31		Mult. x units in AA or BB $PN_1 = 2^{-23} \times AA$ or BB
68		71	74	0	22	27		is 22.03 clear?
74		79	80	0	03	30		Yes Build Dummy A
75		77	78	0	03	30		No Build Dummy B
80		82	36	4	26	22		Clear counter #1 (22.02) and store Dummy A in 22.03
78		80	82	4	26	22		Clear Counter #2 (22.00) and store dummy B
82		84	86	0	22	28		Counter 2 to AR
86		87	89	0	22	29		Add dummy A
89		91	91	0	31	31		NC AR
AR <91	U	NN	96	0	AA	20		4 words of AA \rightarrow line 20
96	U	U1	U2	0	W	23		Line 20 \rightarrow line 23
U2		U5	U6	0	22	28		Dummy B \rightarrow AR
U6		00	17	0	22	29		Add Counter 2
17		19	19	0	31	31		NC AR

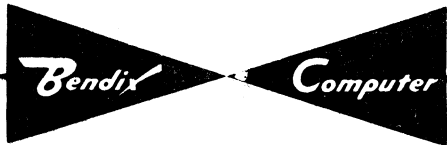

Los Angeles 45, California

Page 2 of 4

G-15 D

Prepared by A. Record

Date: 8/28/61

PROGRAM PROBLEM: Comparator AN-1

Line 03

L	P	T or LK	N	C	S	D	BP	NOTES
AR 19	U	NN	24	0	BB	21		4 Words of BB → line 21
24	U	29	29	0	30	27		$\overline{20.21}$ = zero? Has there been a failure? Error Test #1
29	U	34	35	0	21	20		No L21 → L20
30		31	67	0	00	00		Yes Do nothing
35	U	40	42	0	23	21		Line 23 → Line 21 = Line 20 → Line 21
42	U	47	55	0	30	27		$\overline{20.21}$ = zero? Second test for error.
55		56	58	0	22	28		No Counter 2 → AR
56	U	61	61	0	20	21		Yes Restore time 21
58		62	64	3	03	29		Sub limit
62								6800000 = 104
64		65	69	0	28	27		Has limit been reached
69		71	13	1	17	31		Yes Test punch switch
70		73	81	0	03	29		No Increment counter #2 Add 108
73								6W00000 = 108
81		84	86	0	28	22		Store Counter #2
61	U	66	67	0	23	20		Restore Line 20
67		69	10	0	29	28	-	Clear AR
10		12	15	0	22	28		Counter #2 → AR
15		18	18	0	23	31		Clear PG
18		19	20	0	28	24		WD x 2 ⁻⁸ → MQ1
20		22	25	4	03	25		1/10 x 2 ⁻²¹ → ID
22		(9999U00)						
23		(-00000W)						

RM
CD
17.0

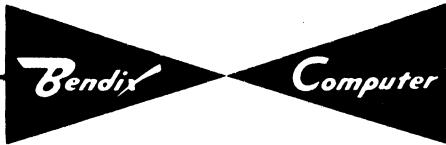

Los Angeles 45, California

Page 3 of 4

G-15 D
PROGRAM PROBLEM: Comparator AN-1

Prepared by A. Record

Date: 8/28/61

Line 03

L	P	T or LK	N	C	S	D	BP	NOTES
25		16	43	0	24	31		Multiply $PN_1 = 1/10 WD \times 2^{-29}$
43		44	46	0	29	26		Clear PN_0
46		48	63	4	26	25		$PN \rightarrow ID$
63		16	83	0	26	31		Shift $ID_0 = 1/10 WD \times 2^{-8}$
83	U	96	04	0	25	29		$6 ID_0 + 6 ID_1 \rightarrow AR +$
04		05	21	0	28	25		$WD (BCD) \rightarrow ID_1$
21		02	40	T	26	31		Shift
40		41	87	0	25	28		Store in AR
87		12	26	0	08	31		Type AR as CR P DD CR E
12	U	13	90	0	29	19		Clear Line 19
90		91	65	0	03	28		Command to AR
91	U	00	71	0	20	19		Command #1
65		67	U3	0	31	31		NC AR See 91 or U5
71		72	71	0	28	31		Test Ready
72		74	U0	0	09	31		Type 19
U0		U2	U0	0	28	31		Test Ready
U1		U5	65	0	03	28		Command 2 $\rightarrow AR$
U5	U	00	06	0	21	19		Command #2
								NC AR see 65 above
06		08	07	0	09	31		Type 19
07		09	07	0	28	31		Test Ready
08		10	55	0	28	28		Do nothing
13		15	00	1	21	31		PS off return to beginning of test routine.
14		17	37	0	23	31		PS on Clear PG
37		39	38	1	20	31		Return to marked place



Los Angeles 45, California

Page 4 of 4

Date: 8/28/61

G-15 D

Prepared by A. Record

Line 03

PROGRAM PROBLEM: Comparator AN-1

L	P	T of Lx	N	C	S	D	BP	NOTES
26		28	26	0	28	31		Test Ready
27		28	12	0	28	28		Do nothing

RM : D 17.0

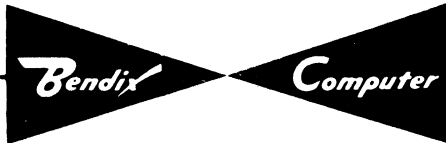

Los Angeles 45, California

Page 1 of 5

Prepared by A. Record

Date: 8/28/61

G-15 D

PROGRAM PROBLEM :

AN-1 Basic Routines #1,2,3,4,5,7.

Line 01

L	P	T or LK	N	C	S	D	BP	NOTES
00		02	00	0	28	31		Test Ready Test No. 1
01	U	02	02	0	06	19		Data to Line 19 Resonance Test
02		04	00	1	03	31		Punch 19
03		05	03	0	28	31		Test ready Test No. 2
04	U	05	05	0	07	19		Data to Line 19 Zig Zag
05		07	03	1	03	31		Punch Line 19
06		08	06	0	28	31		Test Ready
07		08	08	0	25	28		Clear AR
08	U	09	09	0	08	19		Data To Line 19
09		11	10	1	03	31	-	Punch 19 Test No. 3
10		12	10	0	28	31		Test Ready Mode 1
11		13	12	1	17	31		Test Punch Switch Short
12		14	14	1	12	31	-	P.S. off read tape
13	U	14	09	0	08	19		P.S. on reload data
14		16	14	0	28	31		Test Ready
15	U	16	16	1	19	29		Sum 19 in AR
16	U	17	17	3	08	29		Sub out check line
17		19	21	0	28	27		Has error been made?
18	U	19	09	0	08	19		P.S. off reload data
19	U	20	12	0	25	19		P.S. on clear 19
20		(0000818)					

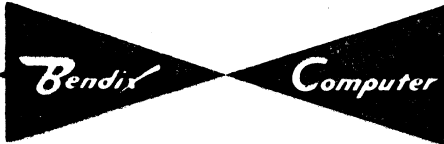

Los Angeles 45, California

Page 2 of 5

G-15D

Prepared by A. Record

Date: 8/28/61

PROGRAM PROBLEM :

AN-1 Basic Routines #1,2,3,4,5,7.

Line 01

L	P	V or LK	N	C	S	D	DP	NOTES
21	U	22	18	1	17	31		No. Test punch switch and ring bell
22	W	23	24	0	01	28		Yes. Command to AR
23	U	00	25	0	19	27	-	Command Test 3
24		26	U3	0	31	31		NC AR Continued
25		27	27	0	08	31		Type AR Mode 1
26	U	27	28	0	19	18		All Line 19 to Line 18 Short
27	W	U0	22	0	00	31		Set Ready
28		20	29	0	01	23		Compare factor to line 23.00
29	W	19	05	3	21	31		Mark and exit to comparator
30								
31		33	31	0	28	31		Test Ready
32		33	33	0	25	28		Clear AR
33	U	34	34	0	09	19		Data to Line 19
34		36	35	1	03	31	-	Punch Line 19 Test 4
35		37	35	0	28	31		Test Ready Mode 1
36		38	37	1	17	31		Test Punch Switch Long
37		39	39	1	12	31	-	P.S. off Read tape
38	U	39	34	0	09	19		P.S. on Reload data
39		41	39	0	28	31		Test Ready
40	U	41	41	1	19	29		Sum 19 in AR
41	U	42	42	3	09	29		Sub out check line

M
D
7.0

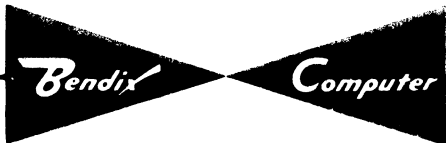

Los Angeles 45, California

Page 3 of 5

G-15 D
PROGRAM PROBLEM :

Prepared by A. Record
AN-1 Basic Routines #1,2,3,4,5,7.

Date: 8/28/61

Line 01

L	P	T or LK	N	C	S	D	BP	NOTES
42		44	46	0	28	27		Has an error been made?
43	U	44	34	0	09	19		P.S. off reload data
44	U	45	37	0	25	19		P.S. on clear line 19
45								
46	U	47	43	1	17	31		No error-Test punch switch and ring bell
47	W	48	49	0	01	28		Error-Command to AR Test No. 4
48	U	00	50	0	19	27		Command Continued
49		51	U3	0	31	31		N.C.A.R. Mode 1
50		52	52	0	08	31		Type AR Long
51	U	52	53	0	19	18		All line 19 to line 18
52	W	U0	47	0	00	31		Set Ready
53		56	54	0	03	23		Lines to compare to line 23.00
54	W	44	05	3	21	31		Mark exit to comparator
55								(See test 5)
56		(0000918)						
55	U	56	59	0	09	19		Data to Line 19
57		59	57	0	28	31		Test Ready
58		59	55	0	25	28		Clear AR
59		61	60	1	03	31		Punch line 19 Test No. 5
60		62	60	0	23	31		Test Ready Mode 2
61		63	62	1	17	31		Test Punch Switch
62	U	67	30	0	25	23		P.S. off Clear line 23
63	U	64	57	0	09	19		P.S. on reload data

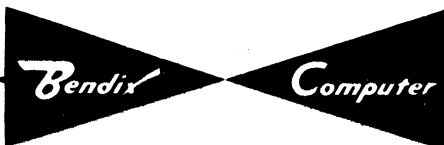

Los Angeles 45, California

Page 4 of 5

G-15 D

Prepared by A. Record

Date: 8/28/61

PROGRAM PROBLEM: AN-1 Basic Routines #1,2,3,4,5,7.

Line 01

L	P	T of LK	N	C	S	D	DP	NOTES
64		66	64	0	28	31		Test Ready
65	U	66	66	1	19	29		Sum 19 in AR
66	U	67	67	3	10	29		Sub out check line
67		69	71	0	28	27		Has an error been made?
68		(0001018)				Test No. 5
69	U	70	59	0	09	19		P.S. off Reload data Mode 2
70	U	71	62	0	25	19		P.S. on Clear line 19 Continued
71	U	72	69	1	17	31		No error-Test punch switch and ring bell
72	W	73	74	0	01	28		Error made-Command 3 to AR
73	U	00	75	0	19	27	-	Command 3
74		76	U3	0	31	31		NC AR
75		77	77	0	08	31		Type AR
76	U	77	78	0	19	18		All line 19 to line 18
77	W	U0	72	0	00	31		Set Ready
78		68	79	0	01	23		Compare Lines to 23.00
79	W	70	05	3	21	31		Mark exit to comparator
80		82	64	1	12	31	-	Read tape
81		83	81	0	28	31		Test Ready
82		83	83	0	24	28		Clear AR Test No. 7
83	U	84	84	0	25	18		Clear line 18 5 Level
84		85	85	1	31	31		Number track-line 18 Number Track
85	U	86	86	0	18	19		Number track to line 19
86		88	87	2	03	31	-	Punch line 19

IM
D
17.0

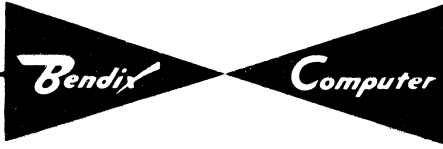

Los Angeles 45, California

Page 5 of 5

Prepared by A. Record

Date: 8/28/61

G-15 D

PROGRAM PROBLEM : AN-1 Basic Routines 1,2,3,4,5,7.

Line 01

L	P	T or Lx	N	C	S	D	BP	NOTES
87		89	87	0	28	31		Test Ready
88		90	89	2	12	31	-	Read Tape
89		91	89	0	28	31		Test Ready
90	U	91	91	1	19	29		Sum 19 in AR Test No. 7
91	U	92	92	3	18	29		Sub out check line Continued
92		94	93	0	28	27		Has an error been made? 5 Level
93	U	99	00	0	17	31		No. Ring Bell Number Track
94	U	95	95	0	19	17		Yes. All line 19 to line 17.
95		96	97	0	01	23		Compare lines to 23
96		(0001718)				
97		U2	98	4	00	20		
98		U4	99	4	00	20		Load special format
99		00	U0	4	20	02		
U0		02	U1	4	20	02		
U1	W	00	05	3	21	31		Mark exit to comparator

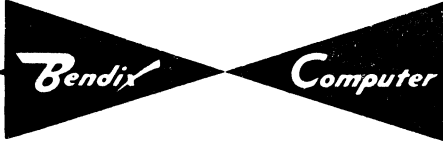

Los Angeles 45, California

Page 1 of 5

Date: 8/28/61

G-15 D

Prepared by A. Record

Line 01

PROGRAM PROBLEM: AN-1 Test 6,8,9, 10

L	P	T or LK	N	C	S	D	BP	NOTES
00								
01		03	01	0	28	31		Test Ready
02		03	03	0	25	28		Clear AR
03	U	04	04	0	09	19		Data to Line 19
04		06	05	1	03	31	-	Punch Line 19
05		07	05	0	28	31		Test Ready
06		11	29	0	25	23		Clear Line 23
07		09	10	0	01	28		P.S. off count down to AR
08	U	09	04	0	09	19		P.S. on Reload Data Test 6
09		(000001)						Mode 3
10		12	10	0	28	31		Test Ready
11		12	12	0	28	27		Is count down complete
12	U	13	14	1	19	29		Yes Sum 19 in AR
13		15	15	1	12	31	-	No Read Tape
14	U	15	17	3	11	29		Sub out check line
15		16	10	7	28	28		Decrement AR
16		(0001118)						
17		19	20	0	28	27		Has an error been made?
18	U	19	04	0	09	19		P.S. off reload data
19	U	20	30	0	25	19		P.S. on clear line 19
20	U	21	18	1	17	31		No error Test punch switch and ring bell
21	W	22	23	0	01	28		Yes error
22	U	00	24	0	19	27		
23		25	U3	0	31	31		
24		26	26	0	08	31		

IM
D
17.0

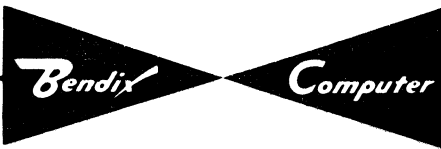

Los Angeles 45, California

Page 2 of 5

G-15 D
 PROGRAM PROBLEM : AN-1 Test 6, 8, 9, 10.

Prepared by A. Record

Date: 8/28/61

Line 01

L	P	T or LK	N	C	S	D	BP	NOTES
25	U	26	27	0	19	18		All Line 19 to Line 18
26	W	U0	21	0	00	31		
27		16	28	0	01	23		Test 6
28	W	19	05	3	21	31		Mark & exit to comparator Continued
29		31	07	1	17	31		Test Punch Switch
30	U	35	07	0	25	23		Clear Line 23
31		32	33	0	01	28		F command to AR
32	U	03	47	0	23	31		F command
33		00	34	0	28	01		F command to 01.00
34	U	35	35	0	25	23		Clear Line 23
35		37	36	0	12	31		Set Input
36		38	36	0	28	31		Test Ready Test 8
37	W	38	39	0	01	28		Precess 19 Type in
38	U	00	40	0	19	27		" Mode 1
39		41	U3	0	31	31		"
40		42	42	0	08	31		"
41	U	42	43	0	19	17		All Line 19 to Line 17
42	W	U0	37	0	00	31		
43		45	44	1	03	31	-	Punch 19
44		46	44	0	28	31		Test Ready
45		47	46	1	17	31		Test Punch Switch
46		48	48	1	12	31	-	P.S. off Read Tape
47	U	48	43	0	17	19		P.S. on Reload Data
48		50	48	0	28	31		Test Ready

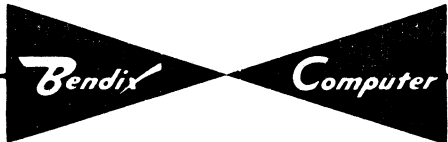

Los Angeles 45, California

Page 3 of 5

Prepared by A. Record

Date: 8/28/61

G-15 D
PROGRAM PROBLEM :

AN-1 Tests 6, 8, 9, 10.

Line 01

L	P	T or LK	N	C	S	D	BP	NOTES
49		50	50	0	25	28		Clear AR
50	U	51	51	1	19	29		Sum 19 in AR
51	U	52	52	3	17	29		Sub out check line
52		53	55	0	28	27		Has an error been made
53	U	54	43	0	17	19		P.S. off Reload data
54	U	55	46	0	25	19		P.S. on Clear Line 19 Test 8
55		57	53	1	17	31		No error Test Punch Switch and ring bell Continued
56	W	57	58	0	01	28		Yes error Command to AR
57	U	00	59	0	19	27		Command
58		60	U3	0	31	31		NC AR
59		61	61	0	08	31		Type AR
60	U	61	62	0	19	18		All Line 19 to Line 18
61	W	U0	56	0	00	31		Set Ready
62		64	63	0	01	23		
63	W		05	3	21	31		Mark & exit to comparator
64			(0001718)					
65								
66								
67	U	72	80	0	25	23		Clear Line 23
68		70	69	0	12	31		Set Input
69		71	69	0	28	31		Test Ready
70		00	79	0	23	20		N → 20.00 Test 9
71		73	73	0	03	31		Punch 19 Punch Leader
72	U	73	74	0	08	19	-	Data to Line 19

MD 7.0

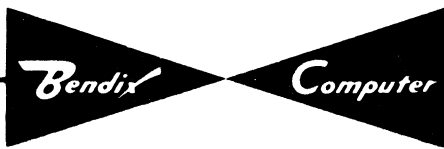

Los Angeles 48, California

Page 4 of 5Prepared by A. RecordDate: 8/28/61G-15 D
PROGRAM PROBLEM: AN-1 Test 6, 8, 9, 10Line 01

L	P	T or LK	N	C	S	D	BP	NOTES
73		74	75	0	28	27		Is enough leader punched?
74		76	77	1	03	31		Punch Line 19
75		77	72	0	00	31		Set Ready Test 9
76		78	71	7	28	28		Decrement AR Punch Leader
77		79	77	0	28	31		Test Ready
78		79	79	0	28	28		
79		00	71	0	20	28		N → AR
80	U	81	68	0	25	19		Clear 19
81	U	86	82	0	25	23		Clear Line 23
82	U	83	83	0	25	19		Clear Line 19
83		85	84	0	12	31		Set Input
84		86	84	0	28	31		Test Ready
85		00	U0	0	23	20		N → 20.00 Test 10
86		88	89	0	01	28		Command to AR Punch Leader
87		40	86	0	26	31		Shift MQ 20 bits 19 Clear
88		00	94	0	25	19		-Sign to 19.XX
89		00	90	1	24	29		Add MQ
90	U	93	93	0	01	29		
91		(000001)				
92		(-000001)				
93		95	93	0	31	31		NC AR
94		96	95	0	03	31		Punch Line 19
95		97	95	0	28	31		Test Ready
96	U	97	97	0	08	19		Data to Line 19



Los Angeles 45, California

Page 5 of 5

Date: 8/28/61

G-15 D

Prepared by A. Record

PROGRAM PROBLEM: AN-1 Test 6, 8, 9, 10.

Line 01

L	P	T or LK	N	C	S	D	DP	NOTES
97		99	98	1	03	31		Punch 19
								Test 10
98		UO	98	0	28	31		Test Ready
								Continued
99	U	UO	UO	0	26	19		Clear Line 19
100		00	87	0	20	24		N → MQ

BM
D
17.0

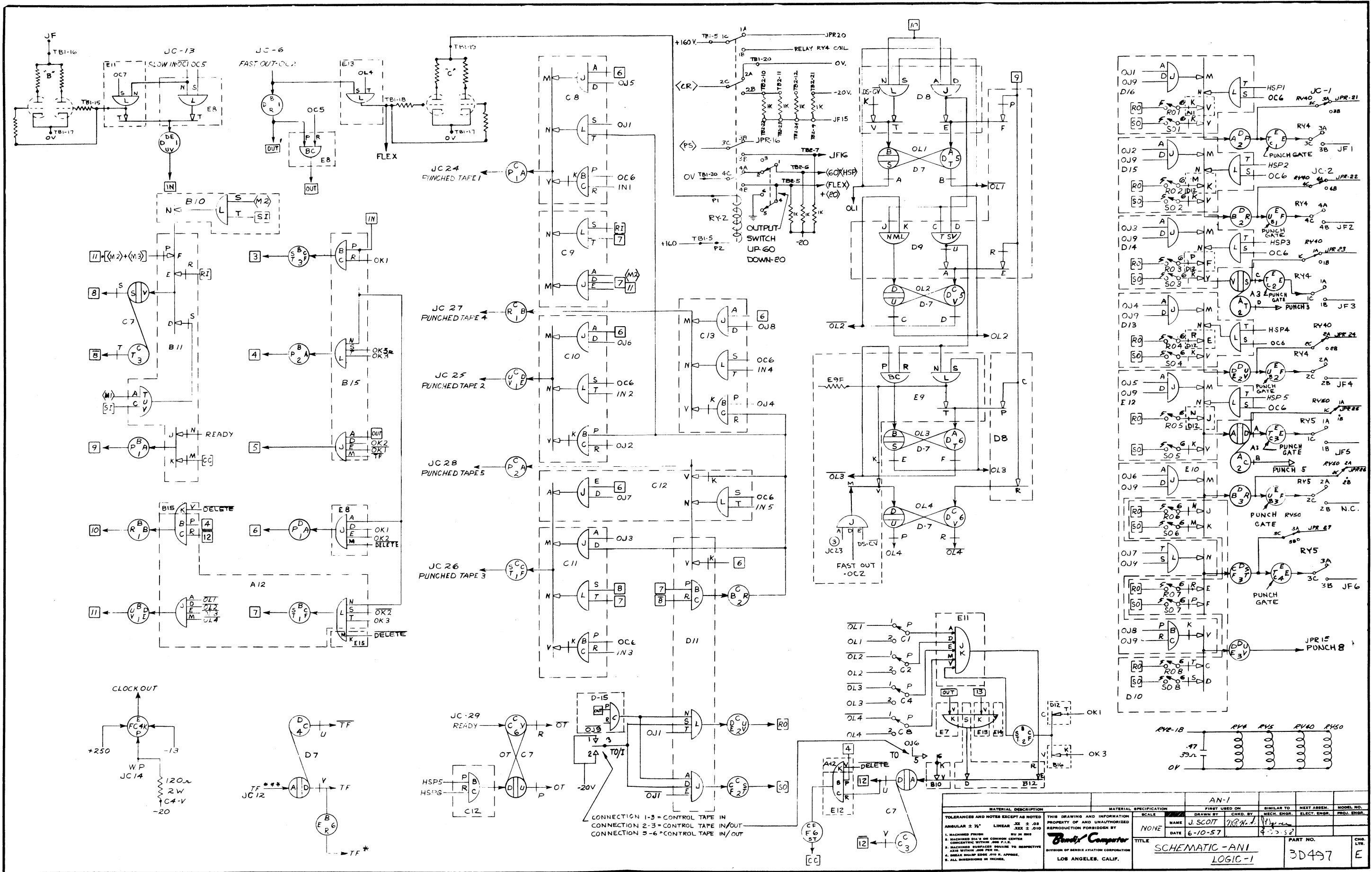
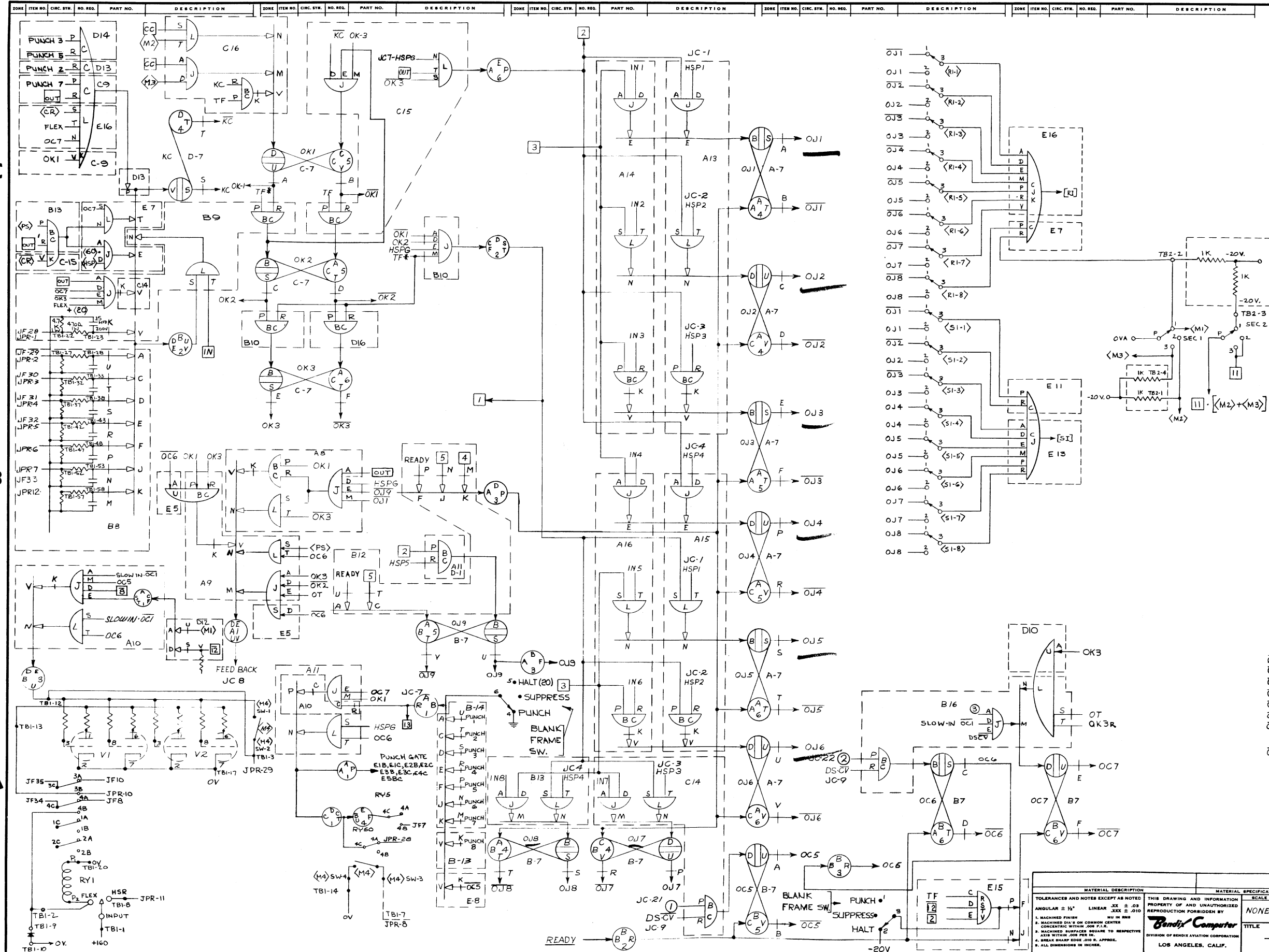
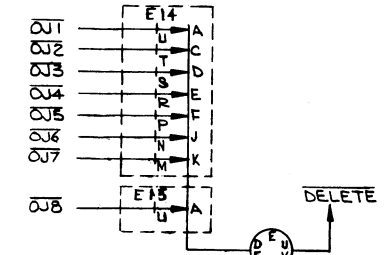

Figure 24. AN-1 Logic -1, Schematic 3D497

REVISIONS			
LTR.	DESCRIPTION	DATE	APPR.
A	PRODUCTION RELEASE	11/1/57	WJH
B	SEE ECO # 981	11/1/57	WJH
C	SEE ECO # 1009	11/1/57	WJH
D	SEE ECO # 1137	11/1/57	WJH
E	SEE ECO # 1172	11/1/57	WJH
F	SEE ECO # 1236	11/1/57	WJH
G	SEE ECO # 1495	11/1/57	WJH



3D496 E



MATERIAL DESCRIPTION		MATERIAL SPECIFICATION		FIRST USED ON		SIMILAR TO		NEXT ASSEM.		MODEL NO.	
TOLERANCES AND NOTES EXCEPT AS NOTED		SCALE		DRAWN BY		MECH. ENGR.		ELECT. ENGR.		PROD. ENGR.	
ANGULAR ± 1/2°		NONE		NAME J. SCOTT		DATE 6-6-57		DATE 11-1-57		DATE 11-1-57	
1. MACHINED FINISH UNLESS NOTED		THIS DRAWING AND INFORMATION PROPERTY OF AND UNAUTHORIZED REPRODUCTION FORBIDDEN BY		Bendix Computer		DIVISION OF BENDIX AVIATION CORPORATION		LOS ANGELES, CALIF.		TITLE SCHEMATIC - ANI LOGIC-2	
2. MACHINED DIMS OR COMMON CENTER		PART NO.		3D496		CHG. LTR.		E			
3. MACHINED SURFACES SQUARE TO RESPECTIVE AXIS WITHIN .004 PER IN.											
4. BREAK RELAY EDGE .010 IN. APPROX.											
5. ALL DIMENSIONS IN INCHES.											

FLOW CHART

AN-1 Test Routines

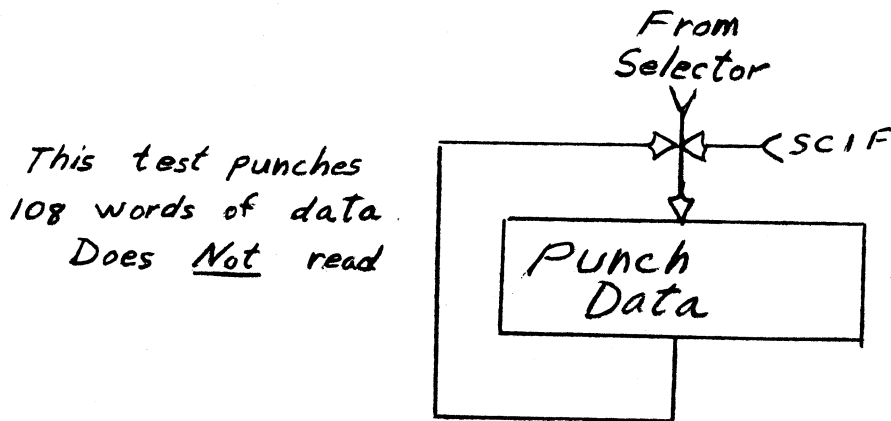
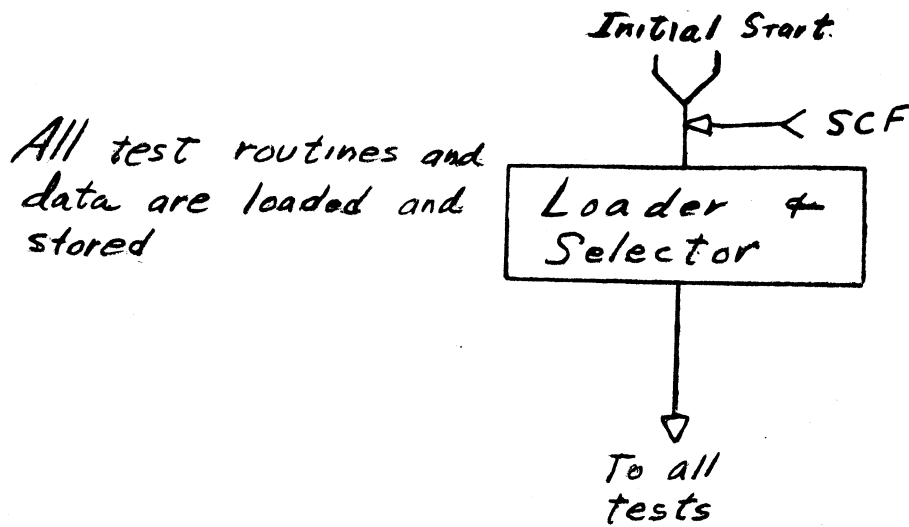

Control Panel Settings

Stop	11000000
Reload	01000000
Output	100
Blank Frame	Punch
Mode	1
Tape Control	Neutral
Input Counter	HSR
	XXXX

TESTS 1 & 2

TESTS 3 & 4

mode 1

Control Panel Settings:

From Selector

Same as tests 1 & 2

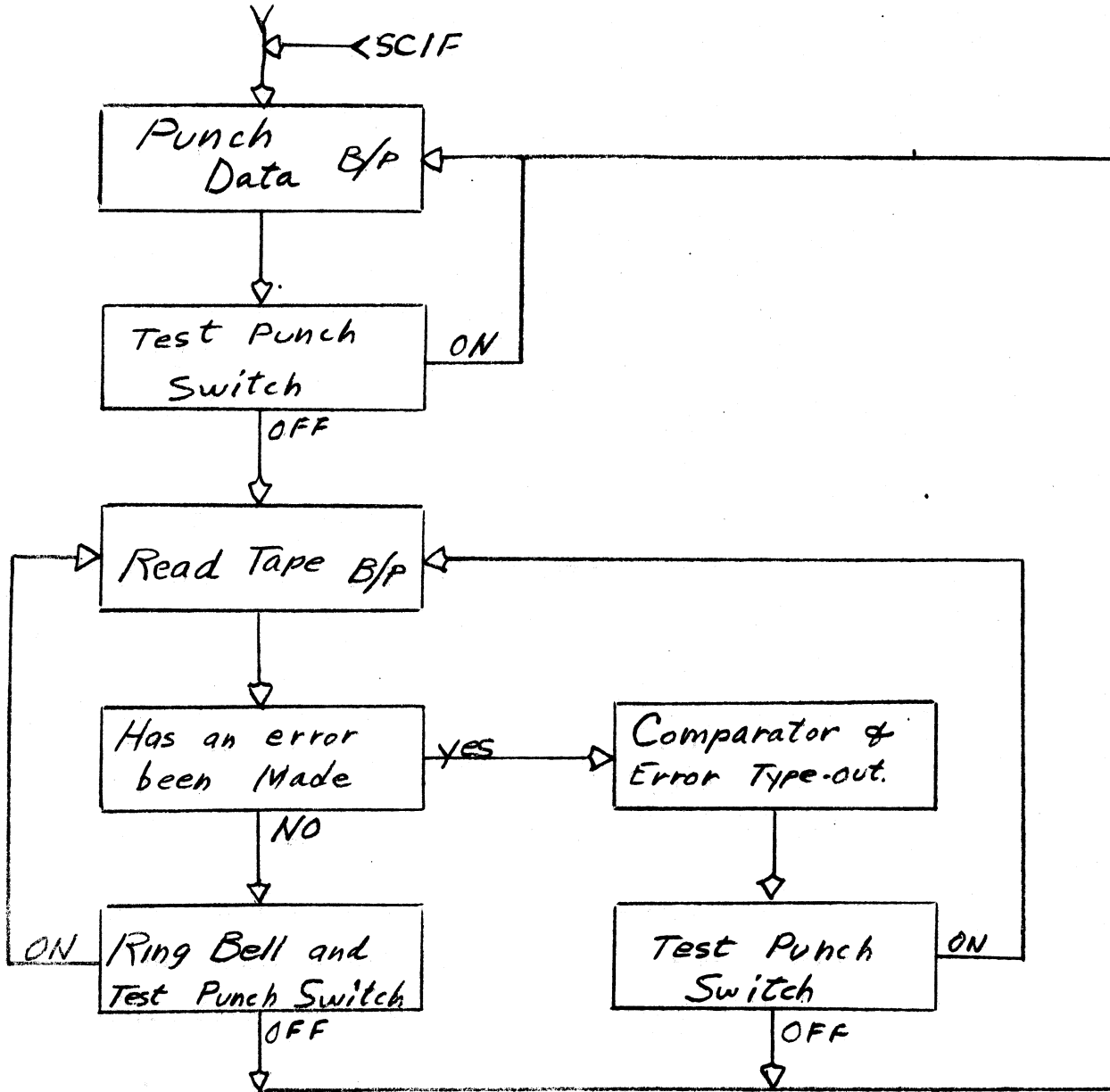

Test 3 is mode one short it punches and reads only 14 characters

Test 4 is same as test 3 except it is 16 time longer in the data punched and read

TEST 5

See tests 3+4 for flow chart

Control panel settings are the same as tests 3+4
except:

Mode = 2

TEST 6

See tests 3+4 for flow chart

Control Panel Settings are the same as tests 3+4
except:

Mode = 3

TEST 7

Standard five level Punch and read.

From Selector

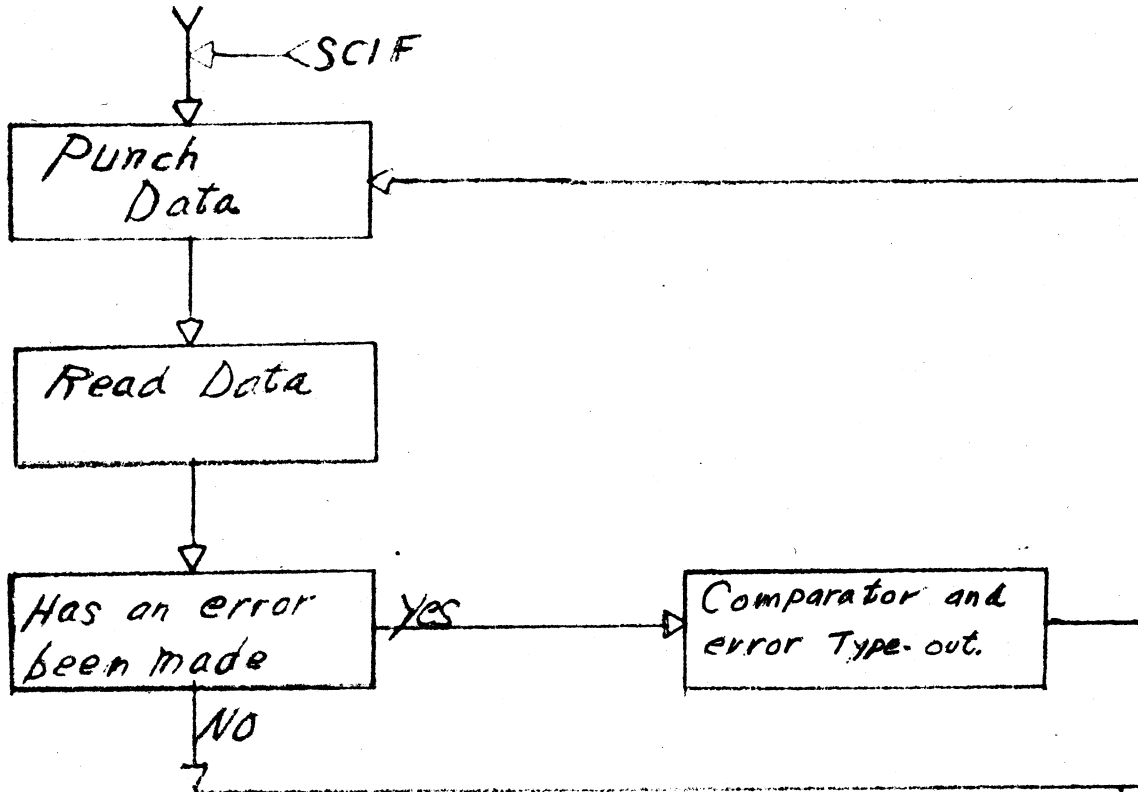

Test 7 punches and reads the number track

Control panel Settings: same as tests 3+4

TEST 8

Type-in Test.

Test 8 permits Type-in of any data up to 108 words into line 17. This data is first punched and read.

Control Panel Settings are the same as tests 3 & 4

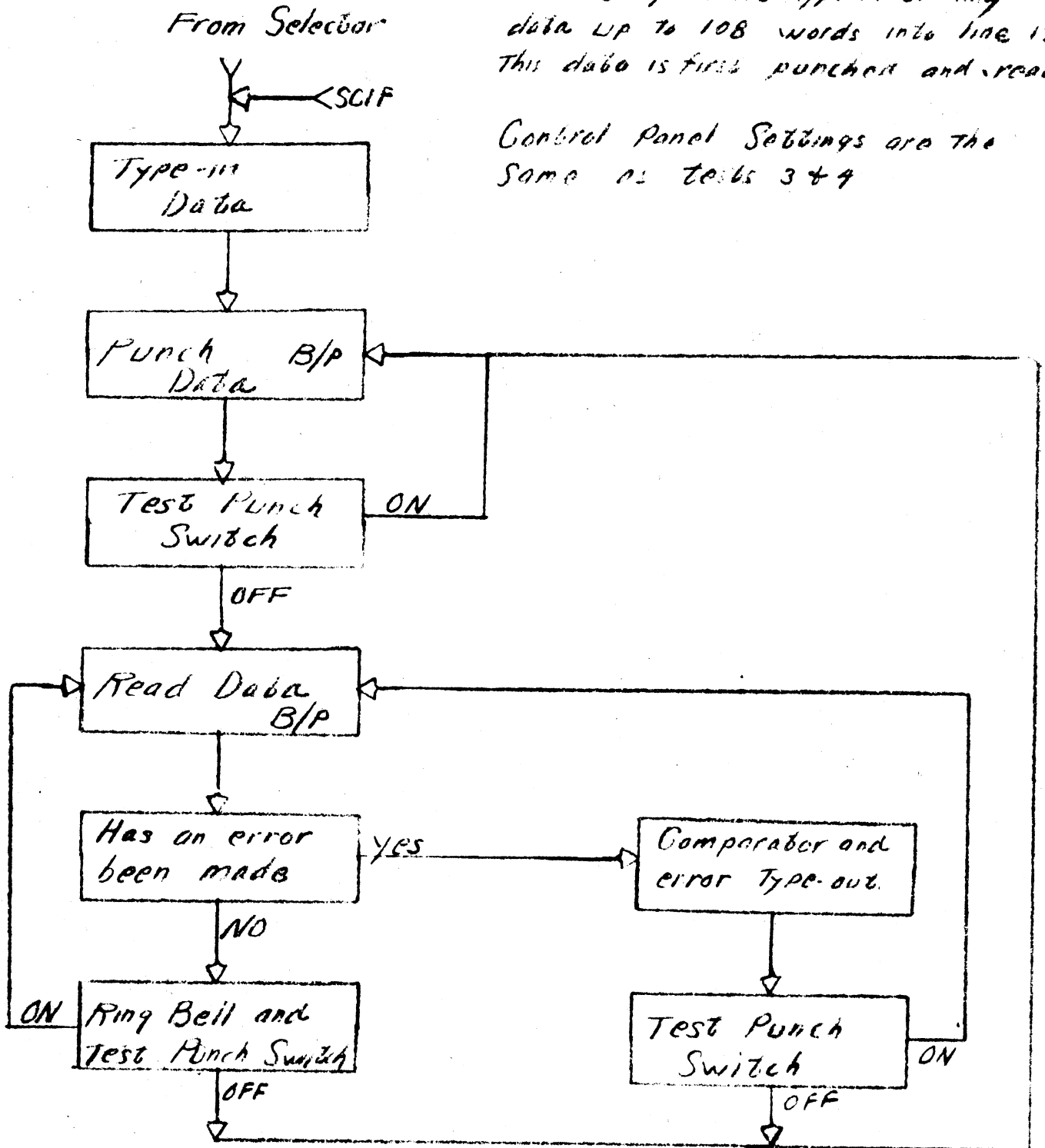

TEST 9

Punch Leader Completely Variable

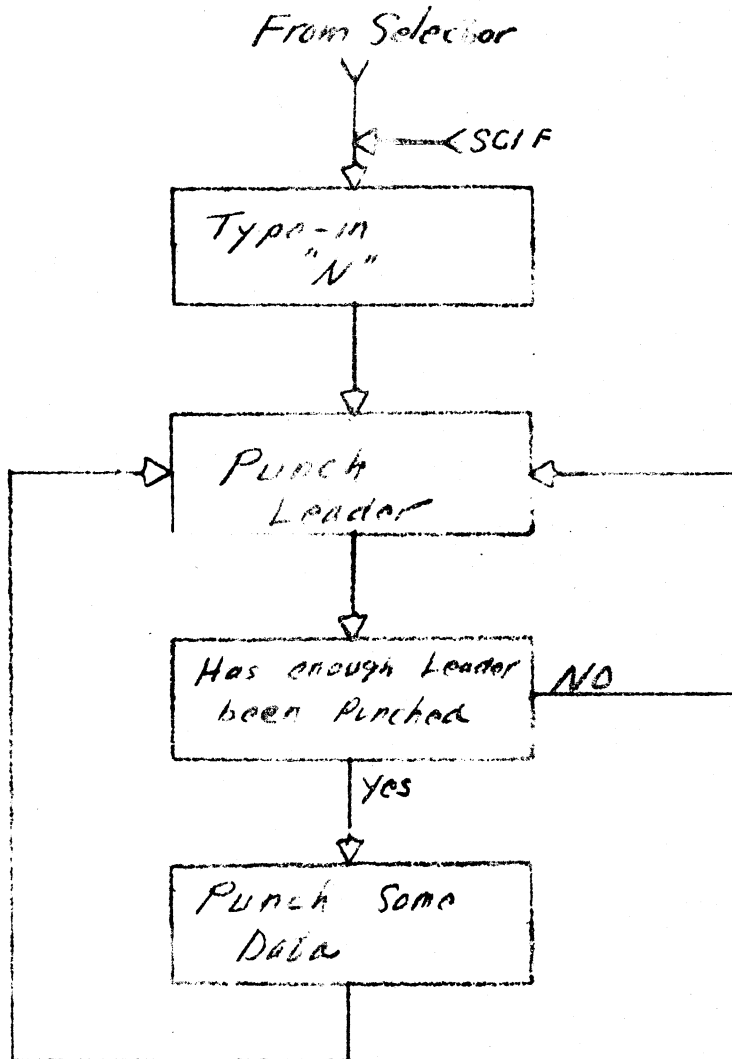

This Test permits the punching of any length of leader proportional to the size of the number "N"

The data punched is just to separate the leaders

TEST 10(U)

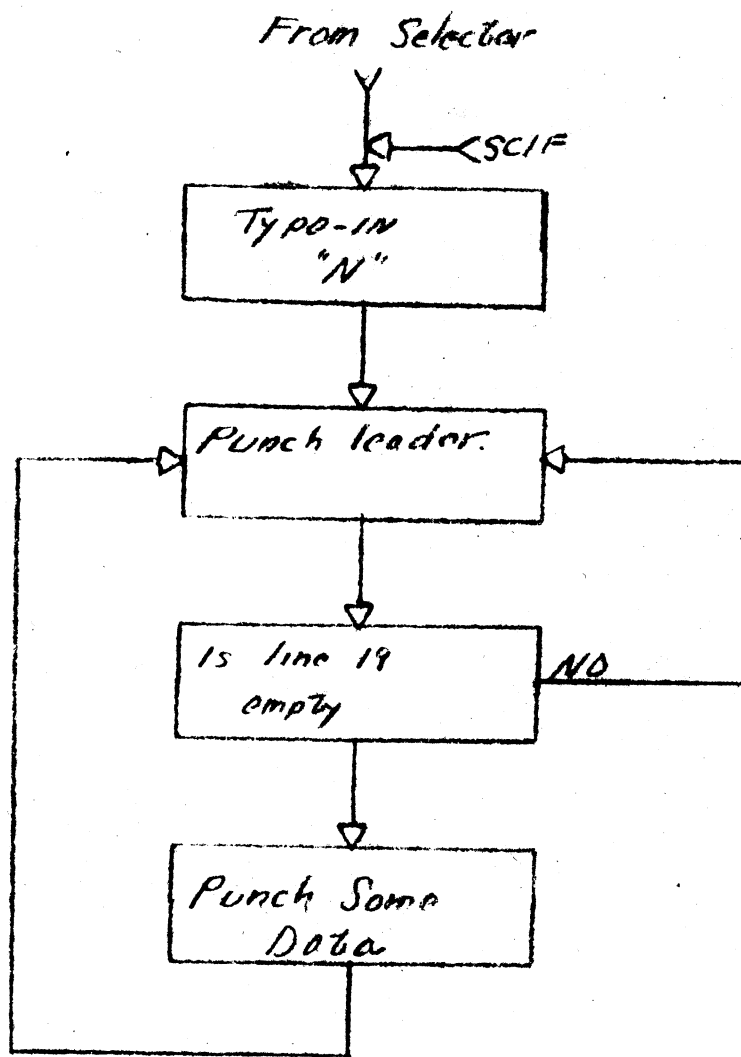

This test permits the punching of leader of length inversely proportional to "N"

N must be in hexadecimal

$$0 < N < 104$$

N must be a zero modulo 4 number.