

DATA MATION ⁷⁸®

SEPTEMBER/3.00 U.S.A.

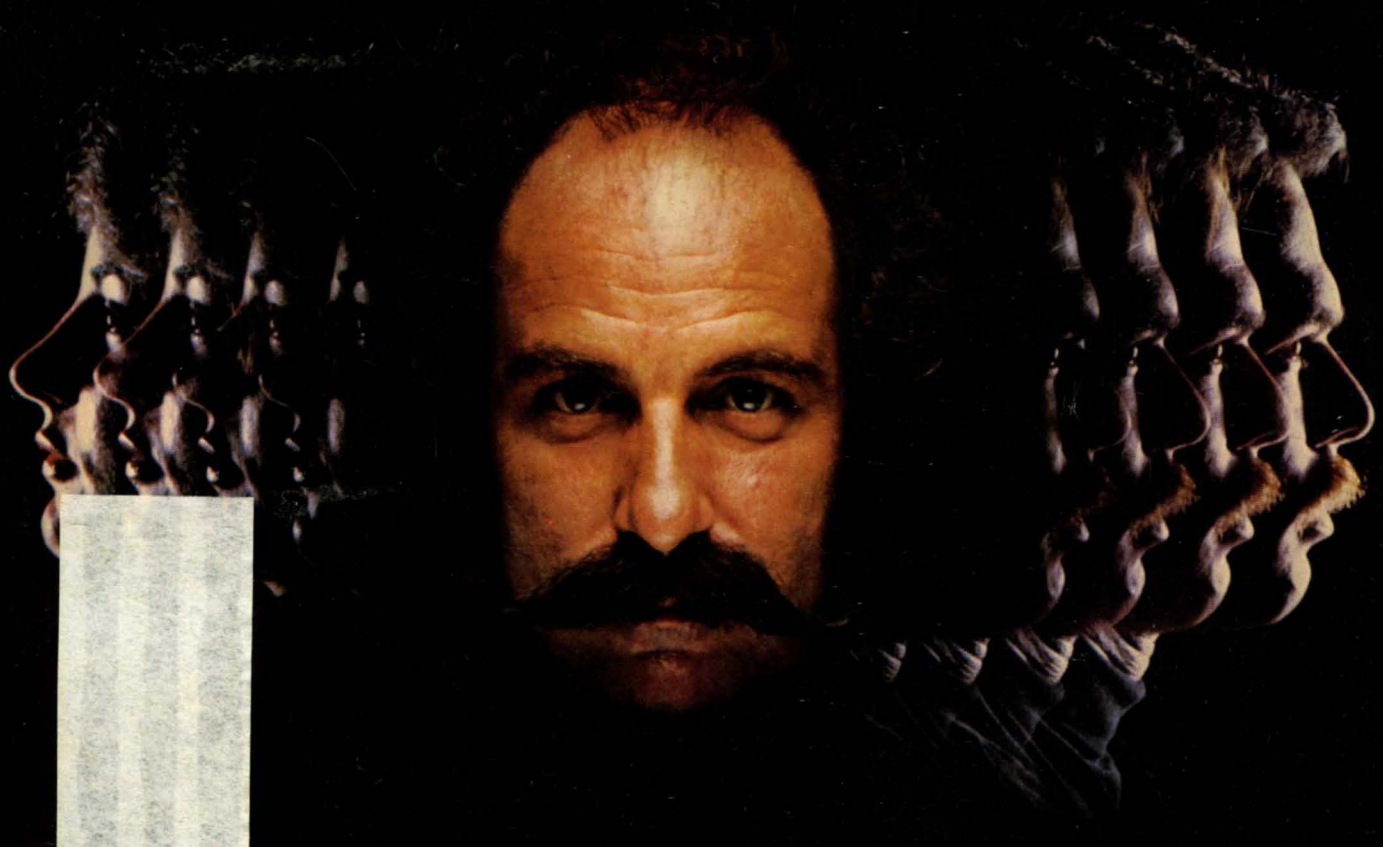

MOTIVATING THE DP PROFESSIONAL

ALSO:

WHAT DP SHOULD
KNOW ABOUT WP
SYSTEMS AND SOFTWARE
RELIABILITY

DISTRIBUTED DOESN'T
MEAN RANDOM

INFO 78 PREVIEW

The One and Only field-tested and proven 125 ips vacuum column tape transport in the industry.

The Kennedy Model 9800. Two years in design, and over two years in the field. That's one reason we don't ask you to evaluate a 9800 — and help us work out the bugs. We've already done that. Just ask any of the more than 3000 owners of Model 9800.

Model 9800 was the first tape transport with such features as a capacitive tape-location detector, air bearings and hard coated read-after-write heads. It's the same story with operating features. Model 9800 offers crystal controlled timing, read threshold scanning, read-after-write shortened skew gate, front-accessible test panel, quick-release hubs and

simplified tape loading — to name just a few. Data densities are 200/556 cpi or 556/300 on the 7-track unit and 800 cpi, 1600 cpi or 800/1600 cpi on the 9-track transport. The format is NRZ1/MP. If you're looking for a 125 ips vacuum-column tape transport, you have two choices. You can help someone else work out the bugs on their transport — or go with the acknowledged leader, Kennedy.

KENNEDY CO.

510 W. WOODBURY RD., ALHAMBRA, CALIF. 91001
(213) 758-0353

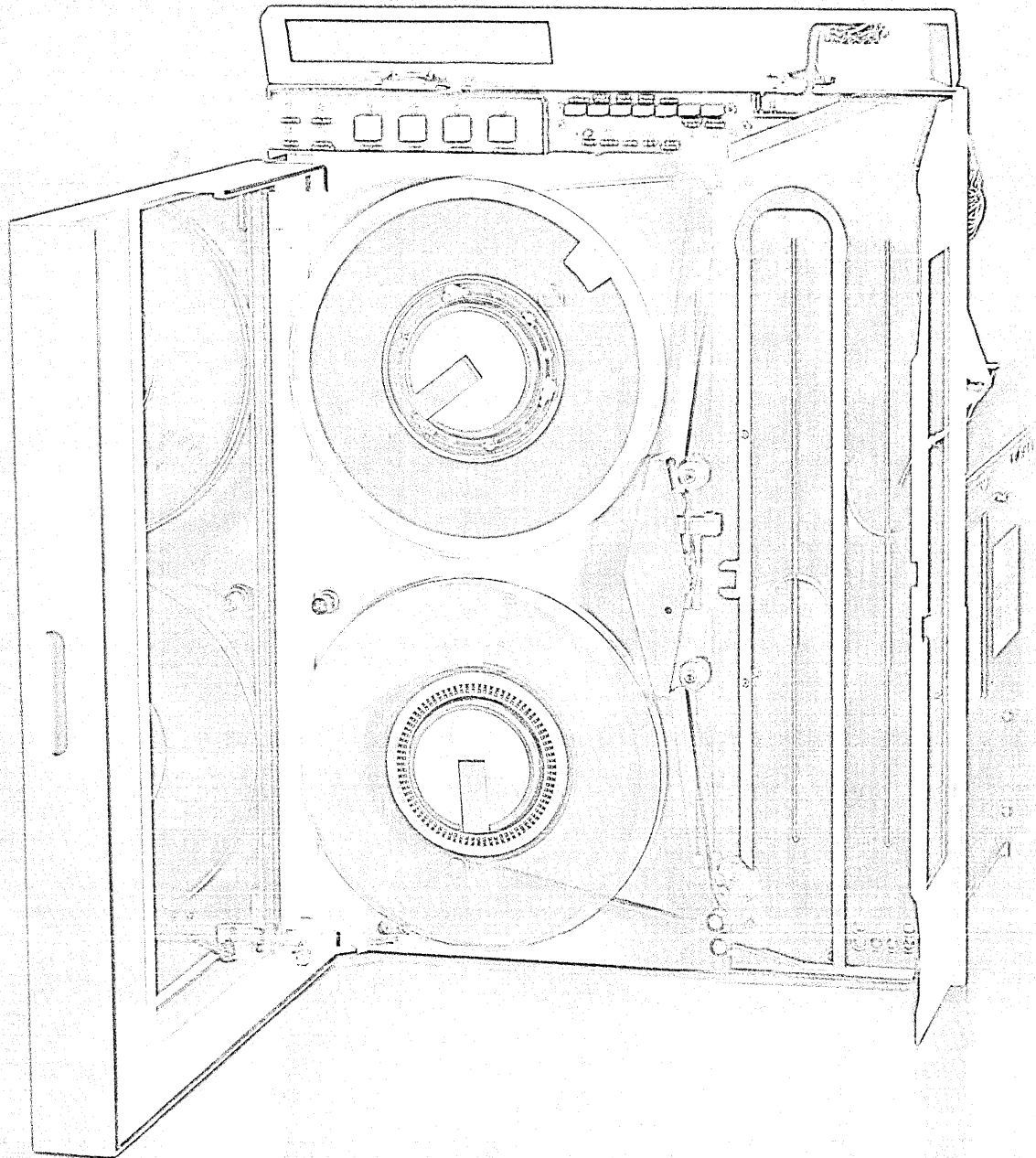

KENNEDY CO. 510 W. WOODBURY RD. ALHAMBRA, CALIF. 91001 (213) 758-0353

Now appearing on your favorite networks: XL Distributed Processing Systems

Your Denver regional office needs up-to-the-minute reports from Los Angeles and Seattle... the central parts depot in Atlanta must maintain current inventory based on information received from six supply centers... Warehouses in Rochester and Raleigh need to access the data base in Atlanta, but don't need local processing... Branch offices in Calgary, Phoenix and Toronto must process orders and transmit to regional managers... headquarters in Minneapolis needs to communicate with all regional and branch offices...

Presenting XL Distributed Processing Systems from Pertec Computer Corporation. A family of microprocessor-based computer systems — and an approach to distributed processing — that cuts through the buzzword maze to provide state-of-the-art hardware and software solutions.

High-power processing

The top-of-the-line XL40 handles up to 16 local and remote terminals. With up to 512K bytes of memory and disk storage expandable to 70 megabytes for local data bases, it can also interactively access your headquarters mainframe via 3270 inquiry mode for non-XL40 resident files. Put one in Denver, another in Atlanta.

Remote Access

XL Remote On-Line SubSystems (ROLS) consist of remote printer/terminal configurations that access the power and data base of the XL40 interactively over telephone lines. ROLS can also take advantage of the XL40's 3270 mode to access the mainframe data base, greatly

enhancing the amount of data available to any one user. Order them for your supply centers and warehouses.

Introducing XL20

And introducing PCO's newest XL family member, XL20, a diskette system for applications requiring local intelligence, data bases, communication and processing power. The XL20 offers your branch offices up to 128K bytes of memory and 48 megabytes of diskette storage. And plus: An optional on-line/off-line feature enables your XL20 terminals to operate interactively with an XL40 and to access the mainframe data base via the XL40 3270 mode whenever necessary.

Designed with compatible hardware architecture and operating systems, XL distributed processing networks install and upgrade simply. And they're supported throughout the United States by more than 400 service professionals in the PCO Service Division.

Call or write today for a detailed brochure on XL Distributed Processing — now appearing on your favorite networks.

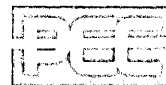

PERTEC
COMPUTER
CORPORATION

CMC DIVISION
12910 Culver Boulevard, P. O. Box 92300
Los Angeles, California 90009
(213) 822-9914 TWX (910) 343-6451

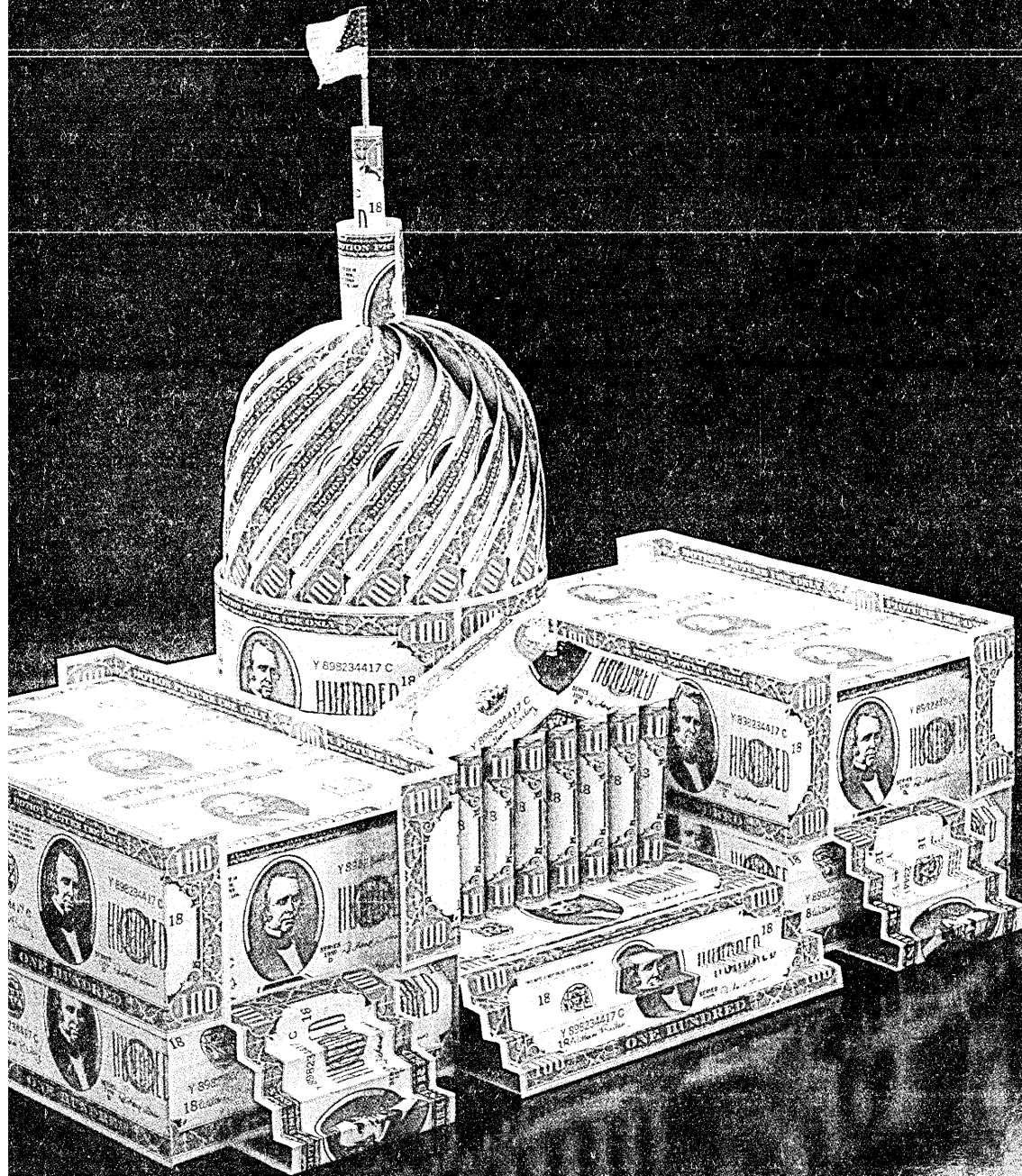

ITEL LEASING. EQUIPMENT FINANCE THAT MAXIMIZES MUNICIPAL TAX DOLLARS.

Itel's Municipal Finance Program offers the most cost-effective means of acquiring the capital equipment that every state and local government needs. We handle all types of tax-exempt financing, including conditional sales as well as short term leases. Our services include:

Custom-tailoring to meet your individual equipment, budgetary and payment schedule requirements;

Interest rates comparable with municipal bond rates;

No-cost termination of the lease for non-appropriation of funds;

Financing for all types of equipment for virtually any terms (for 1 to 20 years);

Assistance with future refinancing, disposition of equipment and termination of existing leases.

Itel Leasing's record speaks for itself. In the past seven years, we've arranged financing for over \$3 billion of equipment. Our success has come

from showing our customers how to more effectively use their capital resources. Now, why not let Itel help you stretch tax dollars to fit your municipal equipment needs?

For further information about our Municipal Finance Program, call Bill Adair collect at (415) 955-0212.

ITTEL
CORPORATION

Financial Services Group
One Embarcadero Center
San Francisco, California 94111

SEPTEMBER 1978/3.00 U.S.A.
 VOLUME 24 NUMBER 9
 This issue 152,000 copies

FEATURES

116 WHAT MOTIVATES DP PROFESSIONALS?

They're not like other professionals after all.

J. Daniel Couger and Robert A. Zawacki

124 WHO IS THE DP PROFESSIONAL?

Mildly paranoid? Eccentric? Slightly neurotic? What's a manager to do?

Jac Fitz-enz

130 ANOTHER REPORT FROM THE PSYCH LAB

With apologies to the more conventional studies of the psychology of computer programming.

Donald Kenney

139 GETTING READY FOR WP'S SECOND GENERATION

Start preparing to use some system before you start to choose which one.

C. B. Carls

153 CONSIDER THE BANK OF AMERICA

After the initial trauma wore off, the bank's move into word processing paid off.

Howard Anderson

165 WHYS AND HOWS OF WP SYSTEM FLEXIBILITY

How to plan for the future while buying today.

William A. Lippold

168 THE NEW WORD PROCESSING MANAGER

You know dp; suddenly you're asked to handle wp . . . and learn a whole new set of SOP's.

Randy J. Goldfield

182 MERGING OF DP AND WP IMPACTS USERS AND VENDORS ALIKE

Combining may be inevitable, but it's still uneasy.

Linda Flato

194 WHAT MAKES A SYSTEM RELIABLE?

Why should a computer be less reliable than an airplane?

George A. Champine

211 A THEORY FOR SOFTWARE RELIABILITY

Changes in programming technique have only marginal impact on program reliability.

Michael G. Walker

219 EXPRESS TESTING

It's based on modifying programmer behavior—and programmers love the results.

Lawrence H. Cooke, Jr.

226 "DISTRIBUTED" DOESN'T MEAN "RANDOM"

In accepting distributed processing, information systems managers will move from being system managers to being information managers.

Ken Falor

233 THIRD GENERATION MYOPIA

The detection and cure of a not so rare disease.

R. Edward Mitchell, Jr.

241 GAUGING THE IMPACT OF CHANGE

Many tools exist for controlling steady state operations; here's one for controlling change.

Joseph R. Matthews and Robert J. Smith

250 INFO 78: CATCHING UP WITH THE NCC

Conference and exposition for information management people should set records of its own.

Tom McCusker

257 THE INTERNATIONAL SERVICES INDUSTRY IN CONFLICT

The battles are the same the world over: micros versus services, IBM versus the communications monopoly.

Ralph Emmett

266 DON'T BET ON PAPER OUTPUT

By 1988, most paper output will have gone the way of the punch card.

Tim Tyler

327 THE FORUM

Ready for more kinds of software taxes?

Robert M. Sherin

NEWS IN PERSPECTIVE

78 PROCUREMENT

csc's huge health contract in California.

The Air Force's Phase IV procurement. How the Air Force buys computers.

82 SERVICES

Service bureaus turn to minis and micros.

84 COMMUNICATIONS

Cut-rate communications charges offered to overseas locations.

88 LITIGATION

A small company fights Digital Equipment in court.

94 MINICOMPUTERS

Market heats up for 32-bit minicomputers.

94 PEOPLE

Spinrad heads Xerox Palo Alto Research Center.

96 INTERNATIONAL

Update: data processing in Israel.

100 BENCHMARKS

104 FOCUS

Citibank's Project Paradise is brought down to earth.

DEPARTMENTS

8 LOOKING BACK	288 SOFTWARE
17 LOOK AHEAD	293 PERSONAL COMPUTING
24 CALENDAR	302 MARKETPLACE
41 LETTERS	309 SOURCE DATA
73 EDITOR'S READOUT	319 ADVERTISERS' INDEX
281 HARDWARE	

ABOUT THE COVER

Our multiple dp personage is the work of photographer Bob Reed.

The New Slimline Series From Okidata

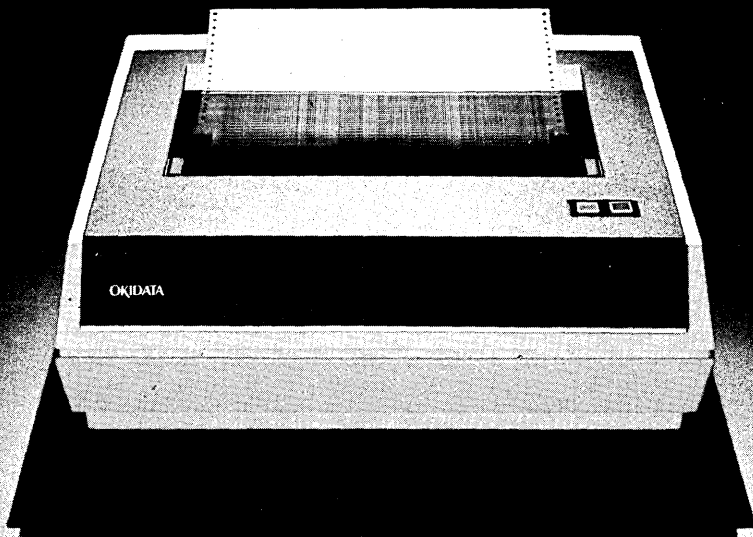

Line Printers That Sell Minisystems

The Okidata Slimline Series, a new family of microprocessor-controlled, 132 column line printers. A wide range of speeds, options and plug-compatible interfaces, all supported with common spares.

Common spares but uncommon price, performance and reliability. OEM prices that create new mini-system opportunities, print quality that helps sell the businessman and Okidata reliability and maintainability—unmatched in the industry. A 500,000,000 character head warranty and stored program machine history that replaces customer installation records.

The Slimline, available in 300, 250, 160 and 125 LPM models. Twelve program-selectable fonts, 5 x 7, 7 x 7 and 9 x 7 characters, and graphics capability. The Slimline, backed by a worldwide sales and service organization.

OKIDATA

Okidata Corporation
111 Gaither Drive
Mount Laurel, New Jersey 08054
Telephone: 609-235-2600

DATAMATION.

Editor John L. Kirkley
Senior Editor W. David Gardner
Senior Editor Richard A. McLaughlin
International Editor Angeline Pantages
European Editor Ralph Emmett
Products Editor Bill Musgrave
Copy Editor John Waterhouse
Articles Assistant Sarah Rolph
Surveys Editor Nancy Knottek
News Editor Tom McCusker

Bureau Managers

San Francisco Edward K. Yasaki
Los Angeles Edith D. Myers
Greenwich Angeline Pantages
New York Laton McCartney
Washington, D.C. Linda J. Flato

Correspondents

Atlanta Lynn Ridlehuber
Boston Vin McLellan
Southwest Robert F. Alexander

Editorial Advisor Robert L. Patrick

Technical Advisor Lowell Amdahl

Contributing Editors Ralph G. Berglund,
Howard Bromberg, Philip H. Dorn, John M.
Eger, William Helgason, Portia Isaacson,
Louis B. Marienthal, Carl Reynolds,
F. G. Withington

EDITORIAL OFFICES

Headquarters: 1801 S. La Cienega Blvd., Los Angeles, CA 90035. Phone (213) 559-5111. **Eastern:** 35 Mason St., Greenwich, CT 06830, (203) 661-5400, Telex 996343. 420 Lexington Ave., New York, N. Y. 10017, (212) 682-7760. 6605 Burlington Pl., Springfield, VA 22152. (703) 569-3383. **Southwestern:** 11500 Stemmons North, Suite 152, Dallas, TX 75299, (214) 247-5221. **Western:** 2680 Bayshore Frontage Rd., Suite 401, Mountain View, CA 94043, (415) 965-8222. **Foreign:** 15 A St. Ann's Terrace, St. John's Wood, London, NW8, England; (01) 722-5088; 24 Stafford Road, Artarmon, Sydney, NSW 2064, Australia, 41-5748. **TELEX 996-343**

Art & Production Director Cleve Marie Boutell
Advertising Production Manager Marilee Pitman
Production Assistant Alberta R. Martin

CIRCULATION

35 Mason Street, Greenwich, CT 06830

Circulation Manager Suzanne A. Ryan

Marketing Research Manager Deborah Dwell

Publisher James M. Morris

Assistant Publisher F. Douglas De Carlo



Circulation audited
by Business Publications Audit



Member American Business Press, Inc.

American Business Press, Inc.



DATAMATION is published monthly on or about the first day of every month by Technical Publishing Company, A Dun and Bradstreet Company, 1301 South Grove Ave., Barrington, Illinois 60010; James B. Tafel, Chairman; John K. Abely, President. Executive and Advertising offices, 35 Mason Street, Greenwich CT 06830, (203) 661-5400. Editorial offices, 1801 S. La Cienega Blvd., Los Angeles, CA 90035. Published at Chicago, Ill. **DATAMATION** is circulated without charge by name and title to certain qualified individuals in the United States and Canada who are employed by companies involved with automatic information handling equipment. Available to others by subscription at the rate of \$26. Reduced rate for qualified students, \$14. Foreign subscriptions \$50, or £27.50; for airmail, additional charge \$40, or £24.50. Japan and Australia \$65, or £86.50 (air shipped). Sole agent for all subscriptions outside the U.S.A. and Canada is J. B. Tratsart, Ltd. 154 A Greenford Road, Harrow, Middlesex HA13QT, England. No subscription agency is authorized by us to solicit or take orders for subscriptions. Controlled circulation paid at Columbus OH. © Copyright by Technical Publishing Corporation, A Division of Dun-Donnelley Publishing Corporation, A Dun & Bradstreet Company, 1978—all rights reserved. * "Datamation" registered trademark of Technical Publishing Company. Microfilm copies of **DATAMATION** may be obtained from University Microfilms, A Xerox Company, 300 No. Zeeb Road, Ann Arbor, Michigan 48106. Printed by Beslow Associates, Inc.

Circulation Office: 34 East Putnam Avenue, Greenwich, CT 06830. **POSTMASTER:** Form 3579 to be sent to Technical Publishing Company, P.O. Box 2000, Greenwich, CT 06830. Publication Number: 148800. Single copy: \$3.00 in U.S.A.

ADR's MetaCOBOL® Makes Structured Programming Work for Sweden's KF

Four years ago when Sweden's \$2.8 billion/year Kooperativa Forbundet (KF) adopted structured programming, they chose ADR's MetaCOBOL as the tool to make it work.

"If we had implemented structured programming without using MetaCOBOL, the COBOL code we produced would not be clear," explained KF's Mike Evans. "We could get the original code to look tidy if we put a lot of comments around it. But we knew there was a great risk that the person who maintained that program would not be as tidy as the one who wrote it.

"With MetaCOBOL, the structure is in the code. Our programmers know immediately what is happening without superfluous comments. And, when the programmers maintain their programs, they

With MetaCOBOL, the structure is in the code.

have automatically documented the changes because the documentation is all right there as part of the code.

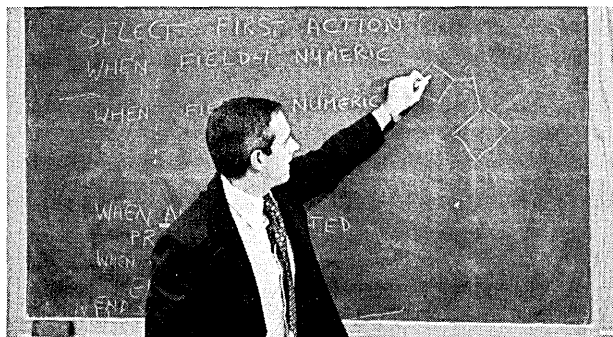

"Our programmers can pick up a MetaCOBOL structured listing they have never seen before and can follow what happens. MetaCOBOL supports structures with one entry and one exit so that they

Today our programmers make fewer mistakes and spend less time on maintenance.

can be regarded as black boxes. Programmers do not need to be concerned about what happened inside because they know that a given structure always yields a certain result.

"Today our programmers have no doubt that MetaCOBOL's structured programming language is the only way to write programs. They make fewer mistakes, they spend less time on maintenance, and they can handle a larger workload."

MetaCOBOL is ADR's COBOL-oriented software product for developing and maintaining programs at either the conventional COBOL or higher level. MetaCOBOL is now in use at more than 450 sites throughout the world for structured programming, for code generation, for conversion from one COBOL dialect to another, for natural interfacing to a data base management system, for auditing for adherence to local programming standards, for systematic testing, and for dozens of other cost-effective applications. MetaCOBOL is saving countless hours of programming effort while making dramatic improvements in overall program quality.

—To find out what MetaCOBOL can do for you — clip this.—

Send MetaCOBOL product information and case histories.

Please call me. I would like a MetaCOBOL presentation.

Name/Title

Company

Address

City/State/Zip

Telephone

Computer Configuration



APPLIED DATA RESEARCH THE ON-LINE SOFTWARE BUILDERS®
Route 206 Center, Princeton, N.J. 08540, Phone: 609-924-9100

Each ADR product is not just a program but a complete package with full documentation and on-site support. ADR is the only software company with 50 branch offices and representatives in over 30 countries—each staffed with ADR-trained technicians.

ADR software products: in use at over 8000 installations worldwide. U.S. offices in Atlanta (404) 252-9130, Chicago (312) 694-2244, Cleveland (216) 826-0190, Houston (713) 526-3188, Los Angeles (213) 826-5527, New York (212) 986-4050, Princeton (609) 924-9100, San Francisco (415) 391-0690, Washington, D.C. (703) 281-2011. International offices in Argentina, Australia, Austria, Belgium, Brazil, Canada, Chile, Denmark, England, Finland, France, Germany, Holland, Hong Kong, Israel, Italy, Japan, Korea, Malaysia, Mexico, New Zealand, Norway, Philippines, Puerto Rico, Republic of South Africa, Singapore, Sweden, Switzerland, Taiwan, Thailand, Venezuela.



Introducing the HP 1000 model 45.

**A powerful
number cruncher
that won't
break your
budget.**

Most engineers and scientists will find all the power they need in this new leader of the HP 1000 family. A new floating point processor handles big data arrays and cuts lengthy computational problems down to size. And the HP 1000 Model 45 also has the flexibility for complex measurement and control applications, for data base management and distributed networking.

And it isn't hard to get your hands on all this computational power. System prices start at just \$46,500*.

Our new F-Series processor is the hard-working heart of the system. It's extremely fast, completing load and store operations in 900 nanoseconds. The separate hardware processor does floating point calculations at high speeds, too—630 ns for add, 1.8 microseconds for multiply and 3 microseconds for divide.

A special scientific instruction set, standard in the system, also helps to improve execution speed, performing trig and log functions in less than 48 microseconds. And a fast FORTRAN processor, which

handles commonly used FORTRAN operations in hardware, also gets things done in a hurry.

Our RTE-IV real-time operating system, the latest in an upward compatible family, lets you manipulate data arrays up to 1.8M bytes, using simple FORTRAN commands. As many as 64 partitions, with a program capacity of 54K bytes, can be resident in memory at the same time.

The HP 1000 Model 45 comes with a fast (25 msec seek time) 20M byte disc drive and an HP 2648A Graphics Terminal, as well as our new Graphics/1000 support software to help you write graphics programs. You can also team it up with other HP products like the HP 9872A four-color plotter and the HP 7245A printer/plotter.

Adding data base management is as simple and economical as adding peripherals. Our IMAGE/1000 software will consolidate your technical information into related and easily accessible files. And you can pool data from other HP 1000 systems (as well as linking to our powerful HP 3000 general purpose computers and IBM) with the help of DS/1000 networking software.

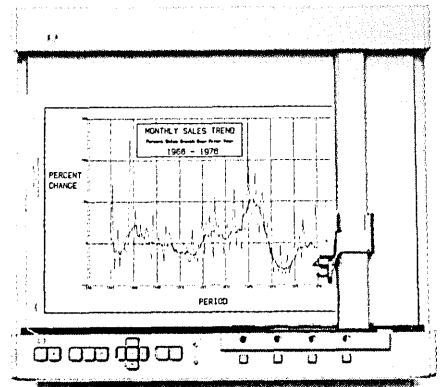

In addition to getting graphic displays on the 2648A terminal, you can get hard copy graphics on our new 9872A programmable four-color plotter, one of many options available with the HP 1000 Model 45. It has a built-in microprocessor and operates up to 360 mm/s (14 inches/s) on each axis. Ideal for vector analysis trace differentiations and window plotting.

So if you've got some big jobs to do, but don't have a big budget to match, the HP 1000 Model 45 can solve your problems fast. To find out all about it, call the HP office listed in the White Pages. Or send us the coupon. We'll prove once again that good things do come in small packages.

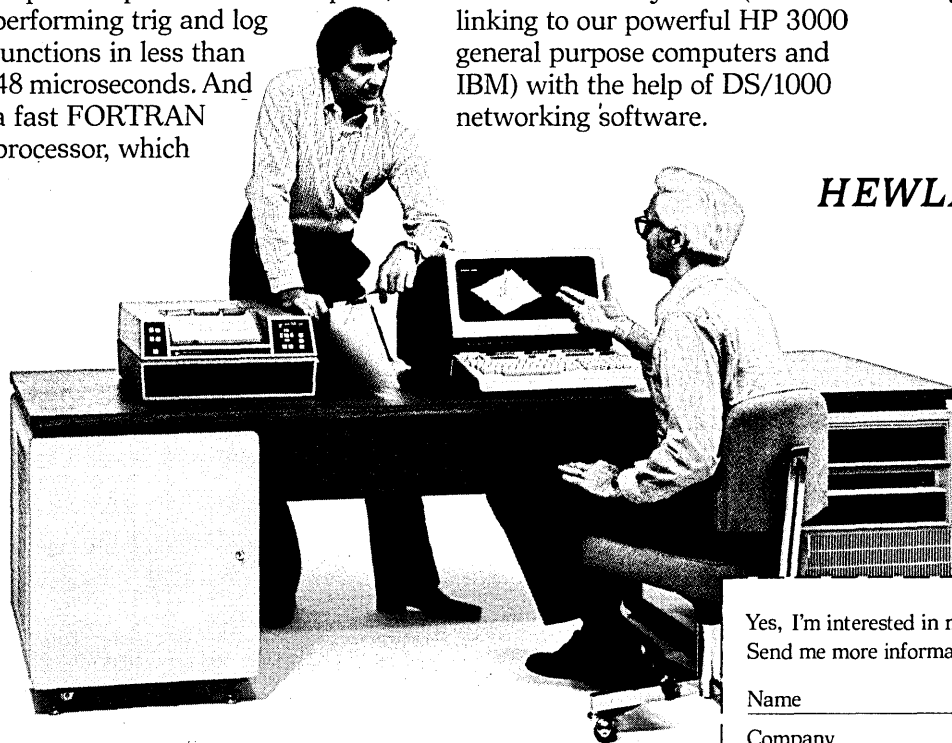

HEWLETT *hp* PACKARD

**U.S. domestic list price*

Yes, I'm interested in more computation power for my money. Send me more information.

Name Title

Company

Address

City/State/Zip

Phone

Mail to: Hewlett-Packard, Attn: Bob Puette
11000 Wolfe Road, Dept. 425
Cupertino CA 95014

Not just
a bar code.
A concept.



* A B C D + 1 2 3 4 *

CODE 39^{T.M.}

an alphanumeric
bar code with
exceptional
data integrity.

Why are more systems designers specifying CODE 39 whenever there is a need to track, trace, or count?

Because they recognize the many inherent advantages of this bar code concept. Advantages like accurate and rapid data input. Advantages like compatibility with existing data base systems and use by operators without keyboard training.

Because CODE 39 is alphanumeric and variable length it easily conforms to existing systems. CODE 39 can be expanded to the full ASCII character set.

CODE 39 is inexpensively produced by letterpress, offset printing and a variety of computer-controlled terminals, including Intermec printers.

Typical Applications

*Inventory Control
Wholesale Distribution
Production Control
Hospital Record Systems
Libraries/Research*

For more information contact:

Interface Mechanisms, Inc., P.O. Box "N," Lynnwood, WA 98036, Phone (206) 743-7036, TWX (910) 449-0870

INTERMEC[®]

Expert in Bar Code

|| READERS || PRINTERS ||

TWENTY YEARS AGO/TEN YEARS AGO

LOOKING BACK

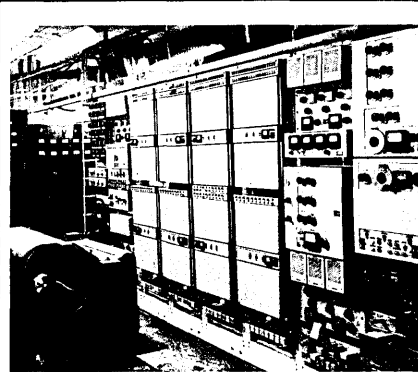

The Musasino 1 computer.

September/October 1958 YEAR OF THE PARAMETRON

It seems that 1958 was a great year for unique computers. In last month's Looking Back we reported on the perceptron, a system that promised not only to think thoughts but to think original thoughts at that. Alas, the perceptron became one of evolution's drop-outs.

In the very next issue of DATAMATION, a Japanese computer utilizing devices called "parametrons" made its debut.

Saburo Muroga, a senior research engineer from Nippon Telegraph and Telephone, explained in obfuscated engineerese the principle of the parametron. Said Muroga, "A small signal which takes one of two possible phases has been amplified into one with much larger amplitude which retains the original phase. And it is interesting to note that these two possible phases are different from each other by pi radiation; that is, the voltage of one oscillation is equal to the minus of the other."

Interesting indeed. E. Goto of Tokyo Univ. decided to apply the parametron principle to switching circuits and, by devising a three beat excitation and a majority decision logical operation, he developed a sort of shift register. A computer was aborning.

5,356 parametrons found their way into the Musasino I large scale digital computer, a 256 word machine used to calculate tables of elementary functions. The arithmetic unit used 2,800 parametrons, the control unit contained 1,600, and 1,456 were in the magnetic

memory; 519 vacuum tubes helped matters along.

Parametrons, it seemed, had an amazing MTBF for those days; at the time the article was written they had been running for 4,000 hours with the only failures occurring because of easily repaired soldering defects.

The M-1 was sure but it was slow. Its speed was somewhat less than that of existing vacuum tube computers. We'd be interested in learning whatever became of the M-1.

Also in this issue was a feature article focused on the problems of dealing with "the presently unmanageable mass of technical information . . ." Charles P. Bourne and Douglas C. Englebart, both of the Stanford Research Institute, posed six pages worth of pertinent questions which they felt must be answered before an effective information system could be designed. At the same time Congress was studying an SRI draft program for a National Technical Information Service.

September 1968 COMPUTER AIDED INSTRUCTION

All the problems that have kept CAI from gaining a toehold in the schools today were being talked about ten years ago in this issue's opening series of articles.

Cost was a major problem. LSI was just being discussed at an IEEE Computer Group conference in Los Angeles and microprocessors were the stuff of visions.

Work on higher level languages had not progressed to any satisfactory point, instructional material was deficient in quality, and serious linguistic ambiguities involving student natural language response to computer-generated quotations had yet to be worked out. The promise of CAI seemed a long way off.

In the news was the announcement that Computer Sciences Corporation and Western Union had broken off merger talks when AT&T said it would halt negotiations on the sale of TWX to WU. AT&T was also gathering lineage by wresting a stay from the FCC on its decision to allow foreign attachments on common dial-up lines. *

Compugraphic. You may not know us, even though we are a \$160,000,000 New York Stock Exchange company – the world's leading manufacturer of computer driven phototypesetting systems – with our own 300-man field service organization.

But we know you if you're an OEM or large EDP end user – and we know your needs. So we've introduced the Mini-Disk Terminal (MDT) 400 – a very sensibly priced, intelligent terminal you can use for text editing, distributed processing, and or data communications. With complete configurations listing for under \$4,500 plus substantial quantity discounts, the MDT-400 is the most cost-effective terminal of its type on the market.

Don't let the price fool you – MDT-400 is a complete terminal processing system in one compact, desktop package, featuring:

- Full user programmability
- Hardware and software modularity for multiple applications
- Powerful 8085 microprocessor
- Up to 32K bytes of memory
- Keyboard/display mini-diskette, and communications interface
- Complete operating software
- Optional printer

The MDT-400 – a cost-effective, intelligent terminal – backed up by a nationwide service force of 300 service engineers. Manufactured intelligently by a large company you should get to know – Compugraphic.

For more information about the MDT-400, clip and send the coupon below today.



CompuWho?

Cg compugraphic
 80 Industrial Way
 Wilmington, Massachusetts 01887
 (617) 944-6555

Mail to: Compugraphic Corp., Computer Products Sales
 80 Industrial Way, Wilmington, Mass. 01887

The MDT-400 is intelligent. Tell me how I can use it for:

Text Editing Distributed Processing
 Communications Other _____

Name _____

Title _____

Company _____

Address _____

City _____ State _____ Zip _____

Phone _____

DM978

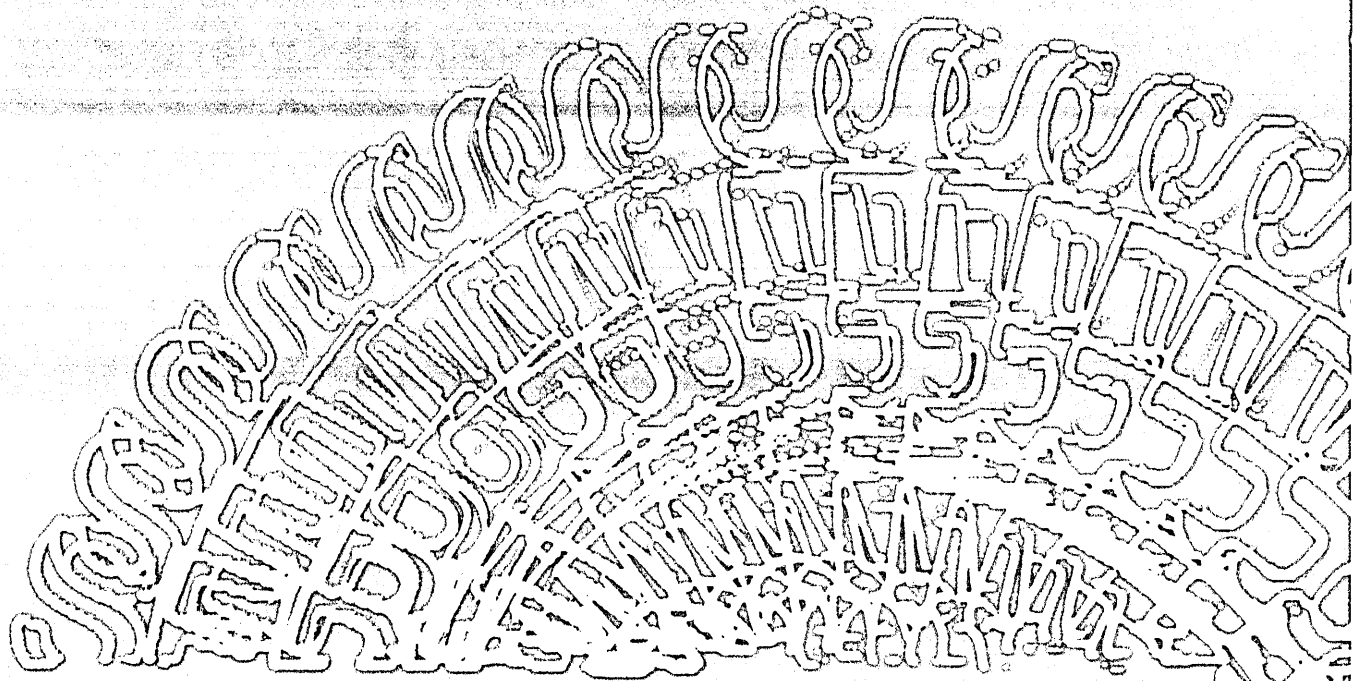

SERIES 9000

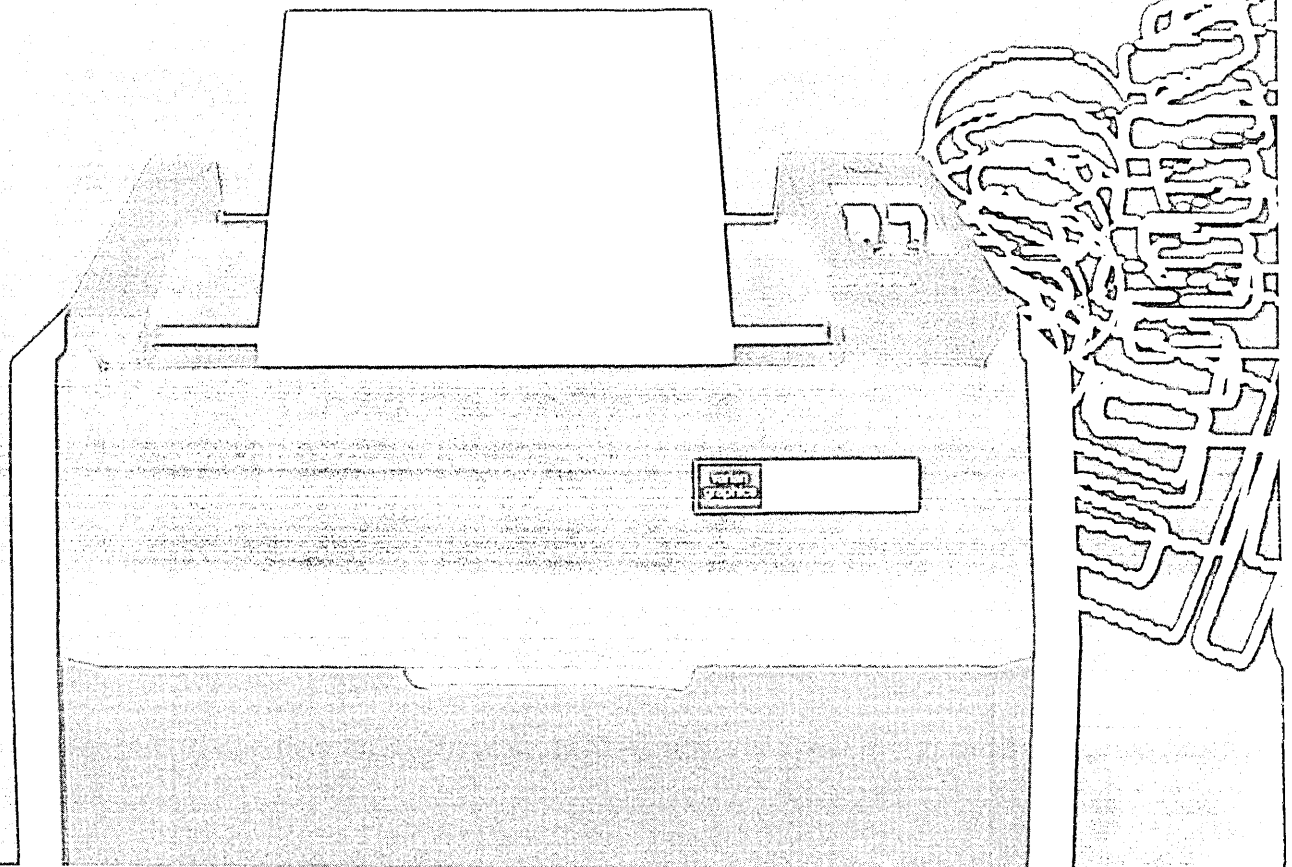

the first electrostatic printer/plotters reliable enough to carry a one year warranty

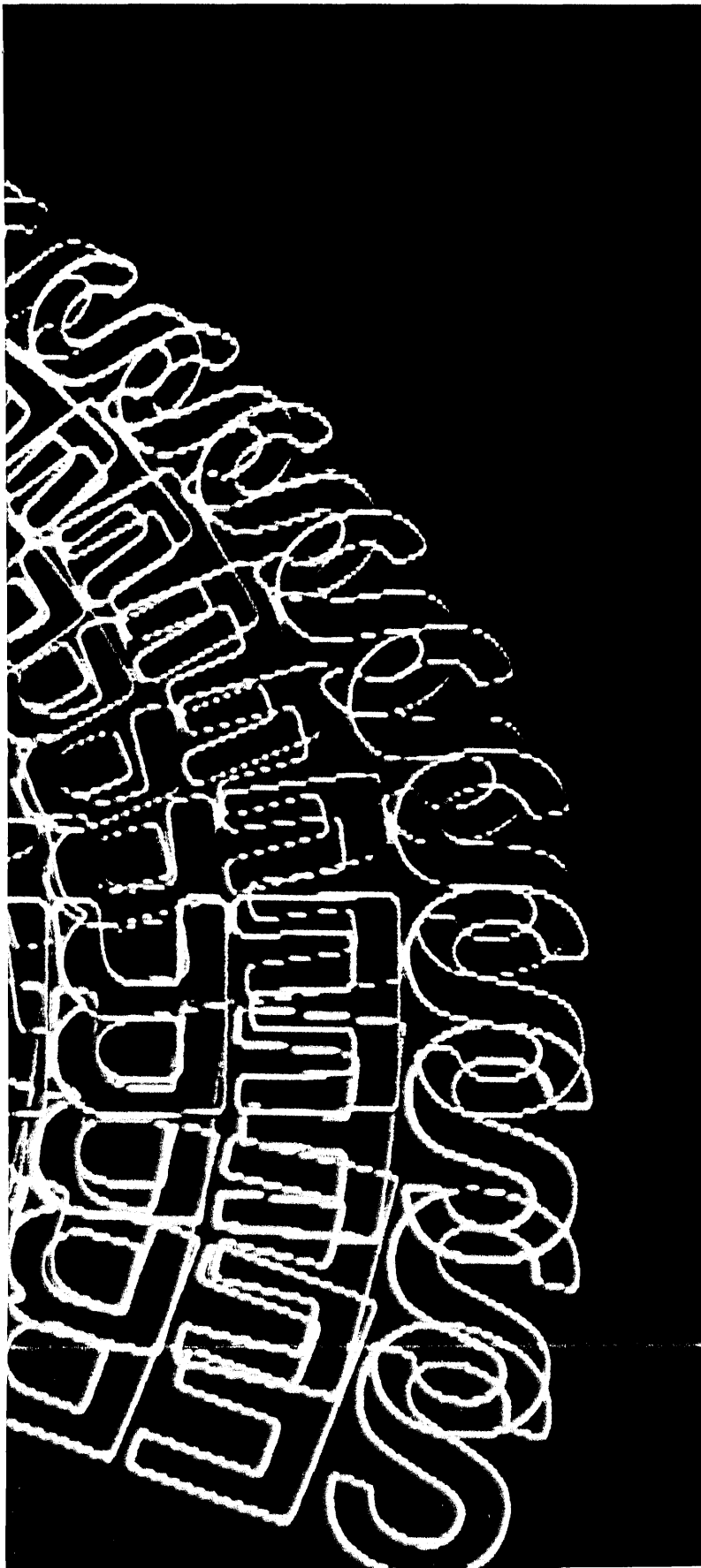

That's right! One full year on parts and labor*, thanks to proven electronics and advanced mechanical design. The result? Consistently superior graphics with minimum operator attention.

- **New Toner System:** Using Varian Graphics exclusive Toner II, expect 100,000 really dry, odor-free copies without changing toner.
- **Supply Level Indicators and Patented Automatic Concentrate Add:** Standard, **not** extra cost.
- **Superior Paper Tracking:** New design for unattended operation.
- **Totally Enclosed Paper Chamber:** For quality output in adverse environments.
- **Reduced Noise:** Quiet enough to operate in an office.
- **Widths Available:** 11", 15", or 22"
- **Resolution:** 100 or 200 dots/inch.
- **Accurate:** Repeat errors less than 0.1%.
- **Improved copy visibility and built-in paper cutter.**

Get the rest of the story. For full details, call, write or send the coupon.

*Terms of 9000 series limited warranty available on request.

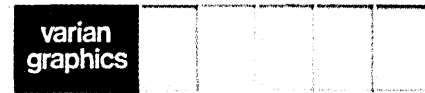

The first name in printer/plotters

611 Hansen Way, Box D106
Palo Alto, CA 94303
TWX 910-373-1731

Tell me about Series 9000

- Series 9000 Brochure
- Detailed statement of Series 9000 warranty terms.
- Series 7000 Pen Plotters: 12" and 34" widths.
- Graphware 360/370: Intelligent Processor for interface to IBM mainframes.
- Buying guide: "Printer Plotter Considerations"
- Put me on your mailing list.
- Call me at _____

Name _____

Company _____

Address _____

City _____

State _____ Zip _____

Application(s) _____

Computer _____

Operating System _____



varian

611 Hansen Way/Box D106, Palo Alto, CA
94303

CIRCLE 147 ON READER CARD

See what you're missing... it's time to ask for a sample of "Vision One" quality image processing: the first choice of specialists.

Comtal is image processing.

By definition, an *image* is the digitally stored representation of the shape and shadings of objects, people or scenes. And, *processing* is the enhancement of brightness, color and definition of the image.

Printed reproductions cannot do justice to the quality of Vision One Image Processing Systems. To see what you're missing, send to Comtal for samples of Vision One image quality and standard interactive processing features.

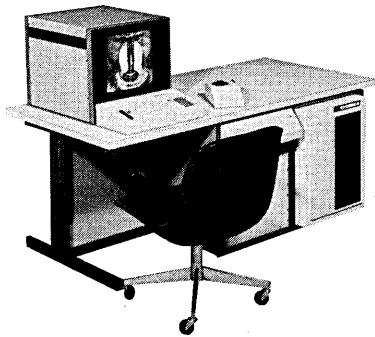

Vision One is delivered ready to operate on digitized imagery without a host system/software development or time-consuming software installation or integration.

To get the full story on what Vision One image processing can offer you, write to COMTAL Image Processing Systems, P.O. Box 5087, Pasadena, California 91107 • (213) 793-2134 • TWX 910-588-3256



Vision One is an intelligent image processing system featuring real-time, completely operator interactive image processing for black and white or full 24-bit color (8 bits each of red, green and blue). Image resolution is 256x256, 512x512, or 1024x1024 pixels with internal solid state memory for up to fifteen 512x512 images (8-bit) and sixteen 512x512 graphic (1-bit) overlays.

Comtal is the acknowledged leader in digital image processing and offers the first commercial system with these features:

Real-time roam of multiple displays in very large data base memories (1977), stand-alone image processing systems, real-time small area independent color correction, and real-time convolution processing (1975). Also, 1024x1024, 256 shade soft-copy display image processing system (1974), full 24-bit color and digital image function and pseudo-color image processing (1973), with single standard digital interface for all features and options (1972).

Comtal has the only commercial systems with real-time operator interactive image processing and hardware generated display of image processing test patterns.

COMTAL[®]
IMAGE PROCESSING SYSTEMS

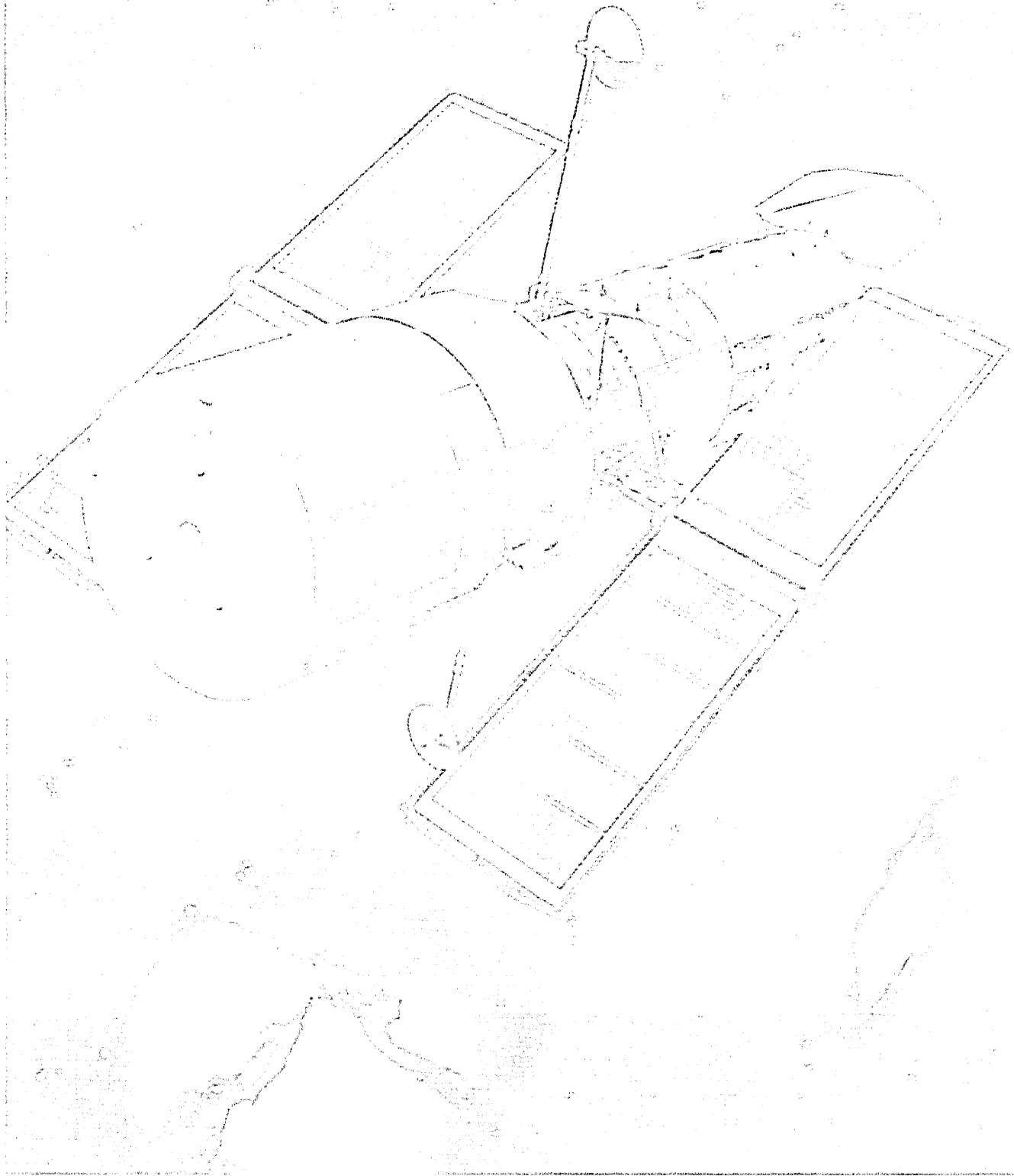

The innovative database system that helps a space-minded company hold costs down to earth.

For two years, Morton Thiore Company has been looking for a way to move a variety of data into a computer system, into their own computer, instead of using expensive outside services.

Their solution was IBM's Model 224.

It's the speed of the interactive

response when Model 224 reports on the transfer of a system that convinced them it was the answer.

Model 224 not only handled the data, but also put it within easy reach of a large number of people — from computer operators to clerks.

If you need a DBMS for your IBM 370/338 or large computer, find out why thousands

of users are turning to IBM's Model 224. Clip your business card to this ad and send to Computer Corporation of America, 575 Technology Square, Cambridge, MA 02139. 617-451-3571.

Computer Corporation of America

Circle 11 on Reader Card

New Developments from SYSTEMS...

The New MOS

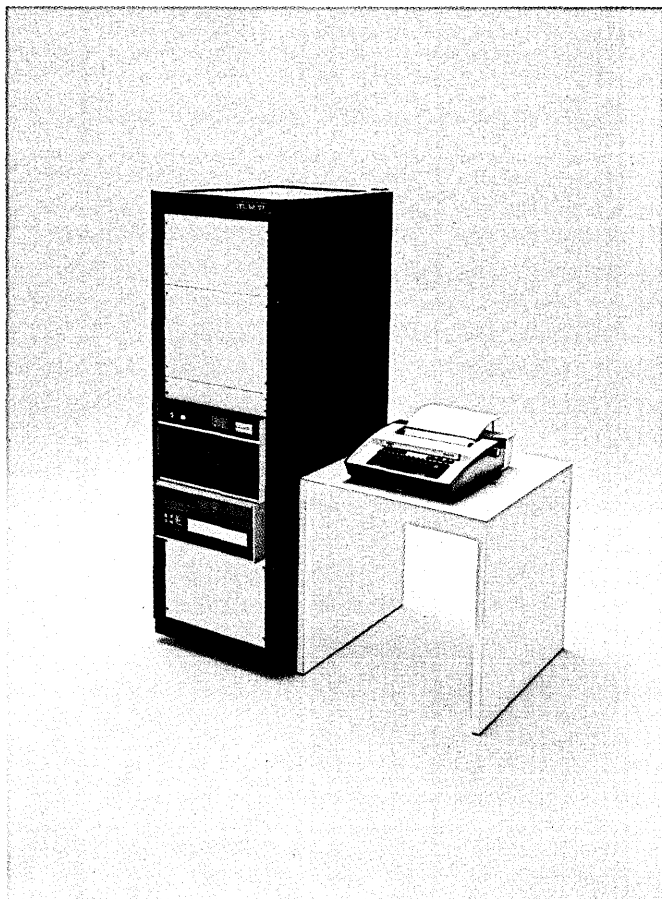

SEL 32/5720



SEL 32/5730

Until now, you've either had to forego 16-bit pricing to get 32-bit performance, or you've had to give up 32-bit performance just to keep the budget in line.

No longer. Now you can invest in a full-blown 32-bit computer system and pay no more than you would for a 16-bit computer. And not have to worry about insufficient power for future needs.

Here's why: value engineering. We've taken our high-performance 32-bit computers, and

we've done some packaging that makes sense. We've added MOS memory. Expanded and fine-tuned our operationally-proven software. Made our systems more compact, more efficient. And we put it all together for a third less money.

The result? A broad family of 32-bit computer systems, perfect for jobs that require high thruputs like telemetry, seismic exploration, or research. Or for jobs that need lots of I/O; process control, simulation, or laboratory automation.

All are upward-compatible, so you can still grow, but start with a minimal investment.

If you'd like to have real performance, but can't overlook how effectively you use your budget, talk to us. We'll make sure that when you invest in SYSTEMS computers, more dollars will flow to your bottom line.

Call us. We're easy to talk to. (305) 587-2900
6901 West Sunrise Boulevard
Ft. Lauderdale, Florida 33313.

Packaged Systems.



SEL 32/5740



SEL 32/5750

SYSTEMS
ENGINEERING LABORATORIES

INTRODUCING THE NEW COMPUTER THAT ISN'T.

The biggest problem with buying a new computer is that you have to buy a *new* computer. An untried, unproven computer.

The new Classic 7870, the newest member of the MODCOMP Classic family, solves that problem. Because it has all the performance features of the Classic 7860, which we introduced earlier this year. Except for one thing. It has four times the memory capacity.



With its large solid state memory (up to 2 million bytes) and an effective memory cycle time as low as 125 nanoseconds, it gives you the speed and capacity you need for demanding scientific, engineering and large process control applications.

And because the 7860 has already been tried and proven, the 7870 gives you something that no other new computer can offer you — a track record.

Classic beats DEC, Interdata, Prime and SEL.

In benchmark tests by computer users measuring both computational and I/O performance, the Classic 7860 has outperformed DEC's 11/70 and VAX. Interdata's 8/32. Prime's 400. And SEL's 32/75.

Hard to believe? Not really. Not when you consider some of the features we've built into the Classic.

Both the 7860 and 7870 have our unique multi-word (16-64 bit) architecture. Pipelined instruction processing. Our super fast floating point processor. And hardware instructions that are specifically designed for fast Fortran execution.

You don't have to trade reliability to get Classic's performance.

The best thing about the Classic isn't its performance. It's the fact that its state-of-the-art performance isn't achieved at the expense of reliability.

Since its introduction, the 7860 has been tested exhaustively by computer users in both scientific and process control applications.

They report that the Classic is as reliable as any computer MODCOMP has ever introduced. And that's saying something. Because independent surveys have consistently rated MODCOMP computers as the most reliable real-time systems on the market.

Why buy a new computer when you can buy our new computer?

The Classic is supported by a comprehensive set of operating systems and network extensions that have been used successfully by some of the most demanding computer users in the world. We also provide all the documentation you need to implement it quickly and easily. Plus a worldwide network of service specialists.

In fact, the only thing the new Classic 7870 doesn't give you is something you don't want anyway.

The problems associated with new computers.

For more information, send for our "MODCOMP Classic Family" brochure.

MODCOMP
Dedicated to your success

Modular Computer Systems, Inc.
1650 W. McNab Road
Ft. Lauderdale, FL 33309
(305) 974-1380

LOOK AHEAD

PROBLEMS WITH 3033 REPORTED BY USERS

Problems with the IBM 3033 continue to surface. One large user, Martin Marietta, Baltimore, Md., has reportedly had trouble keeping its 3033 system up since its mean time between failures (MTBF) has been less than 100 hours. One night late last month, the system went down eight times, reports an industry insider. Although IBM maintains a strict "mums the word" policy on quoting mean time between failure on any of its systems, the normal MTBF is usually clocked at between 400 and 500 hours on most systems. Other 3033 users are also rumored to have had problems getting their systems operational. While the Central Intelligence Agency's 3033 finally is not failing as frequently as it had several months ago, ITEL's 3033, installed in late May, was still not operational as of late in August.

IBM SEEN SLASHING MEMORY PRICES

Look for IBM by next January to slash the price of main memory well below that offered by the most aggressive add-on memory suppliers. Oppenheimer & Co., the New York brokerage firm, says the company will use new high density storage to offer memory at under \$35,000 per megabyte, a major slash from its present price of around \$110,000 and considerably below the \$55,000 per megabyte offered by the independents.

In addition, the price performance curve of mainframes to be announced in early 1979 should be much sharper than generally expected: 4:1 for processor and storage, perhaps, compared with common expectation of 2:1. IBM could make up the difference by charging for its system control programming modules, with IBM software billings to users increasing to about 50% of the total system monthly rental value. (Detailed discussion of the short term outlook for IBM developments, specifically relating them to plug compatible mainframes, will be offered at Oppenheimer's first open conference early in October. The company's computer analyst Gideon Gartner says his firm also will be covering AT&T Advanced Communications Service at the seminar.)

NIXDORF TO OFFER WP SYSTEM IN U.S.

While Nixdorf Computer is rumored to be test marketing a single station word processing unit in Europe, it's understood the firm's U.S. operation is designing a multiterminal shared processor word processing system. Test marketing of the U.S. product should begin soon. One potential user has been told the system will be based on the firm's Entrex hardware and software. The Nixdorf system's printer is likely to have a daisywheel design and Entrex software is being tailored to make the system simple to use. The announcement should be forthcoming late this year.

BRITAIN'S SILICON ISLAND

Some industry pundits in Britain now refer to that nation's electronics industry as "Silicon Island," after the fuss raised over Britain's moves into the microelectronics business (August, p. 73). The reference, of course, is to Northern California's

LOOK AHEAD

Santa Clara Valley, home of many of the leading U.S. semiconductor manufacturers. Britain's government has promised a \$300 million initial investment in the effort and about 5,000 new jobs are to be created at two major manufacturing ventures. One is Inmos, started from scratch but using talent from Mostek, a company that is far away from Silicon Valley, in Texas. Mostek, meanwhile, has taken legal action, charging that along with people, Inmos is taking away trade secrets. Inmos doesn't expect to enter the 64K RAM market until 1982, however. Meanwhile, Fairchild has a deal with Britain's GEC in which each will pump an initial \$20 million into their advanced circuits and memories operation in Europe.

What bothers many on this side of the pond are the lucrative salaries being offered talent from U.S. semiconductor firms to settle and make their fortunes in Britain and on the European continent. Mostek, for instance, already has lost seven of its top persons to Britain. Next target could be the Valley, say British observers.

ACADEMY TO PROBE PRIVACY PROBLEMS

Computer-spawned privacy problems may get a new probing by the National Academy of Science's National Research Council. The impetus for the study came last month at an NRC hosted meeting on computer based information technology. A draft report of the high level government/industry conclave is due out in October. Bundled into that report, one source reports, will be a recommendation calling for an NRC directed research effort to deal with privacy problems stemming from organizational relationships. Specific areas of concern would be electronic funds transfer system (EFT), criminal justice information system, and the Post Office's moves in the area of electronic mail.

MODEM RIGGED FOR HIGHER SPEEDS

What do you do when you have a network that requires modems to handle transmission speeds of 6000bps? If you have a 4800bps modem with a powerful enough microprocessor built in -- like Paradyne Corp.'s -- you jury-rig the slower speed device to handle the higher speeds. That is precisely what Paradyne has done with its MP 4800 modem, which has become the workhorse model of Scandinavia's Nordic Data Network which, of course, transmits data at 6000bps.

SEEKING UPGRADE TO DEC'S MAIL SYSTEM

With more than 400 subscribers already on line at Digital Equipment Corp.'s COMET electronic mail system, the firm that developed the system -- Computer Corp. of America, Cambridge, Mass. -- is looking at ways to upgrade the system. One possibility would be the use of more of a distributed network for the system, which uses PDP-11s. Several other firms are testing the system with the thought of implementing their own dedicated system some day.

RUMORS AND RAW RANDOM DATA

IBM's 1200MB disk drive, being developed under the code name Whitney, will obey Grosch's Law to the letter: its price will be twice that of the 3350, while its capacity increases fourfold, the square of the price increase...Storage Technology will introduce a charge-coupled device (CCD) memory this month that may have applications similar to Memorex's 3770 Disc Cache CCD memory that provides faster access between a disk and a cpu...The Justice Dept. is said to be stepping up its interviews with IBM competitors and others to come up with some kind of proposal for relief in the IBM antitrust case.

"We couldn't live without MARK IV!"



— Pat O'Grady, Secretary-Treasurer, and Fred Hemming, Director of Data Processing, Transport Indemnity Company, Los Angeles, California

"With 16,000 claims reported annually and \$50,000,000 in annual premiums, Transport Indemnity is one of the largest and busiest truck insurers in the country. To handle this enormous load with ease and efficiency, we use MARK IV. It has reduced our programming time by 75 percent and allowed us to work with a staff one-third the size of what it would be otherwise. It's really unbelievable!

"In 1975, we developed a fully automated and truly revolutionary retrospective claims system under MARK IV, and we're absolutely thrilled with it. Essentially, retrospective claims mean that the insured shares in the lower limits of the loss, with the insured paying in advance for the loss. At year's end, according to the actual experience, additional money is requested or overpayment is refunded.

"This claims process is extremely complex, but MARK IV simplified it and gave us the exacting control we need. All current and cumulative claims information, along with pertinent statistical data, is on one master file. By simply passing our transaction file against it, we spin out all the reports we require.

"We also use MARK IV for an extremely sophisticated self-insurance administration system, and currently 90 percent of our new systems development is scheduled for MARK IV. What we like best is its flexibility.

MARK IV is so responsive that we can answer the changing needs of our insureds through timely production of specialized reports. Our DP people think of MARK IV as a 'language of love'! We couldn't live without it!"

GET THE FACTS ON MARK IV. MARK IV is the most versatile and widely used software product in the world for application implementation, data management and information processing. Six powerful models (prices start at \$12,000) are in daily use on IBM 360/370, Univac 70/90, Siemens 4004, Amdahl 470, and IteI Advanced System computers at over 1,300 installations in 44 countries. Programs in MARK IV require only about one-tenth the statements of Cobol, and users report 60 to 90% cost and time reductions on most MARK IV applications.

informatics inc



Software Products

World's Leading Independent Supplier of Software Products

OFFICES

Los Angeles (213) 822-3552
New York (201) 488-2700
Washington (703) 821-5900
Atlanta (404) 955-2518
Chicago (312) 298-9300
Dallas (214) 750-0800
Canada (416) 493-9716

HEADQUARTERS

21050 Vanowen Street
Canoga Park, California 91304
Telephone (213) 887-9121

Member SIA  Software Industry Association

Transport Indemnity is one of the nation's largest companies specializing in motor carrier liability insurance.

Ampex memory for DEC System 20. Save big money.

ARM-20 is the Ampex memory for Digital Equipment Corporation's 2040, 2050 and 2060 computers. These Ampex add-ons are expandable in increments of 128K words to 512K in each cabinet, with a system maximum of 4 megawords.

ARM-20 provides independent four-way interleaving within each 128K sector. It executes repetitive single-word requests in 625 nanoseconds, and repetitive four-word requests within 1200 nsec. There's also a convenient reconfiguration capability and extensive diagnostics for rapid

fault isolation.

Ampex experience is every bit as impressive as Ampex performance. We've been building memories for large DEC mainframes, including KL processors, for more than ten years.

Ampex add-ons for DEC System 2040/50/60 computers are significantly less expensive. Find out how much you can save as you grow by writing Ampex Memory Products Division, 200 North Nash Street, El Segundo, California 90245. Or call Ted Conant at 213/640-0150.

AMPEX



We can design, install and maintain *any* telecommunications system—large, medium or small.

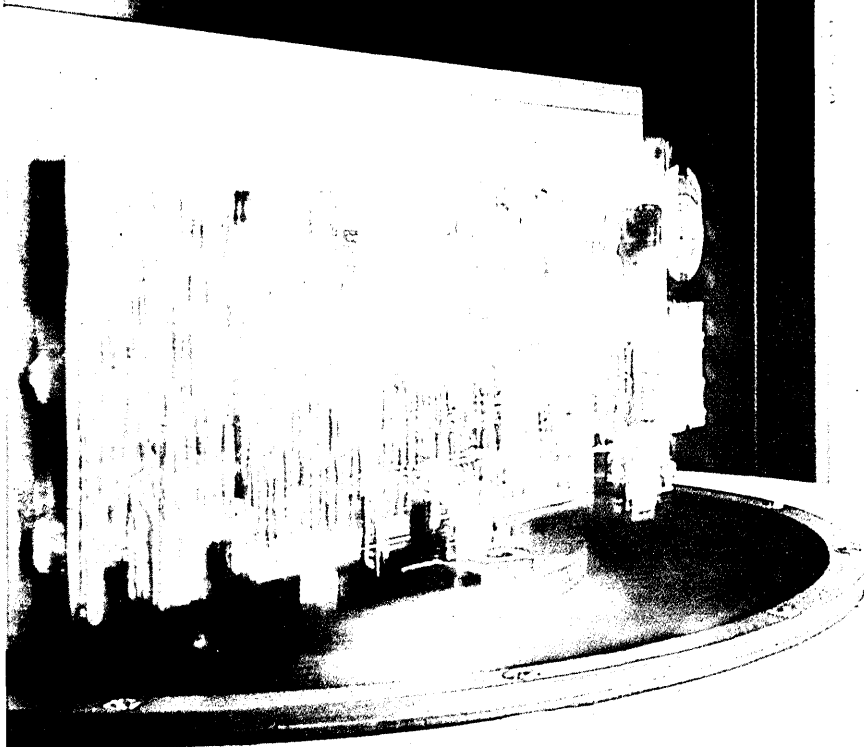

Go on, tax our imagination.

Because when we at Cable and Wireless say 'any', that's precisely what we mean. No matter what you're looking for in a telecommunications system—we can provide it.

Our global organisation is uniquely qualified to plan, design, engineer and install complete telecommunications systems for you. Be it telephony, telex, telegraphy, television, data.

We can operate, manage and maintain the system; train technicians, engineers, managers and operators.

Our up-to-the-minute expertise is relied on by national and international organisations, oil companies, airlines and aviation authorities, banks and shipping the world over.

So, if you feel you'd like more information, why not do a little communicating yourself. Contact us.

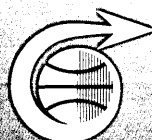

Cable & Wireless

Always a step ahead of today's communications.

Cable & Wireless Ltd, Mercury House, Theobalds Road, London WC1X 8RX. Tel: 01-242 4433. Telex: 23181

CIRCLE 12 ON READER CARD

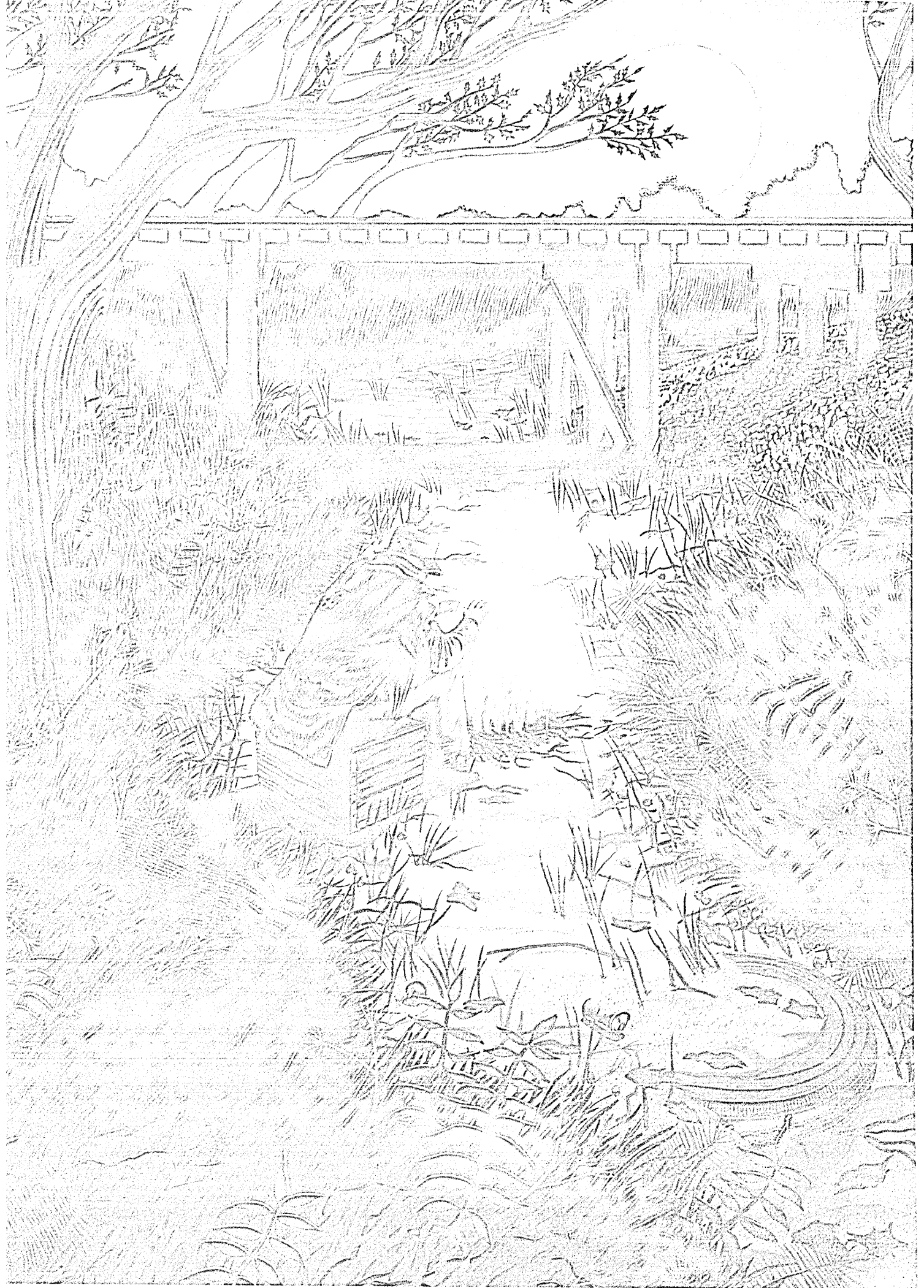

“Whatever happened to ol’ Fred after that little problem with the master file?”

With the UCC-1 Tape Management System, problems just don’t happen.

This software package effectively manages all your tapes, preventing the accidental loss or destruction of your valuable data. UCC-1 eliminates costly, handwritten records... and the expensive mistakes they breed.

There are more than 500 installations of UCC-1, representing about three-fourths of all installed OS tape management systems. To find out why, call us at (214) 688-7312 or circle 90

And, while you’re at it, ask us about:

A DOS Under OS System that lets you use DOS programs, without reprogramming, while you convert to OS (UCC-2). Circle 91

A Disk Management System you should look into before you buy another disk drive (UCC-3). Circle 92

A PDS Space Management System that

eliminates PDS compression (UCC-6). 93

A Data Dictionary/Manager that will really get IMS under control (UCC-10). Circle 94

A Restart/Recovery Management System that makes restarting in a matter of seconds... a matter of fact (UCC-15). Circle 95

A General Ledger/Financial Control System that your Accounting Department has been dreaming of (UCC-FCS). Circle 96

Software packages like these. One more way—

An IMS Database Verifier checks physical pointers, finds errors before they become problems (UCC-40). Circle 97

An IMS Database Space Utilization Program pinpoints DB loading problems (UCC-41). Circle 98

A broad line of Banking and Thrift software. Circle 99

Software packages like these. One more way—

We’re helping the computer to do more of the work.

UCC

P. O. Box 47911 — Dallas, Texas 75247

Canada: 797 Don Mills Road — Don Mills, Ontario M3C 1V2 • Europe: 1258 London Road — London, U. K. SW16 4EG

CALENDAR

OCT.

MIDWEST PERSONAL COMPUTING EXPO, OCT. 5-8, CHICAGO.

Over 20,000 attendees expected. Seminars will range from introductory to advanced. Contact: ISCM, 222 West Adams St., Chicago, IL 60606 (312) 263-4866.

ASSN. OF RECORDS MANAGERS AND ADMINISTRATORS CONFERENCE, OCT. 8-11, WASHINGTON, D.C.

Keynote speaker will be the Honorable Elmer B. Staats, U.S. Controller General. \$205 for nonmembers. Contact: ARMA, P.O. Box 281, Bradford, RI 02808.

THIRD U.S.A.-JAPAN COMPUTER CONFERENCE, OCT. 10-12, SAN FRANCISCO.

Dr. Jerome B. Weisner, president of the Massachusetts Institute of Technology, and Dr. Koji Kobayashi, chairman of the board and chief executive officer of Nippon Electric Co., Ltd., will be the two keynote speakers. The conference is to explore technical advances in the U.S. and Japan and similar and contrasting ways of using computers to solve problems. Contact the Third U.S.A.-Japan Computer Conference, c/o AFIPS, 210 Summit Ave., Montvale, NJ 07645, or call the conference general cochairman, John D. Madden, at (408) 245-5807.

AFSM THIRD NATIONAL CONFERENCE AND EXPO, OCT. 15-18, CHICAGO.

The Association of Field Service Managers is a professional association of managers of complex equipment maintenance. Speaking at the conference will be Ryal Poppa, chairman and president of Pertec Computer Corp.; Archie McGill, director of management development operations at AT&T; Hyde Harper, vice president of field engineering at Satellite Business Systems; La Vern Bassett, senior program manager at Xerox Corp.'s Office Systems Division, and others. Contact: AFSM, P.O. Box 255, Danbury, CT 06810 (203) 744-5707.

COMMON FALL CONFERENCE, OCT. 15-18, DENVER.

COMMON is an IBM users group. Some topics to be covered at the conference include dp management, data base management, and manufacturing applications. Contact: David G. Lister, administrative director, COMMON—Dept. F2, 435 N. Michigan Ave., Suite 1717, Chicago, IL 60611 (312) 644-0828.

INFO 78, OCT. 16-19, CHICAGO.

The theme is to be "Strategic Planning in the Information Age." The emphasis of the technical sessions will be on applications. Contact: Clapp & Poliak, Inc., 245 Park Ave., New York, NY 10017.

FEDERAL MICROGRAPHICS EXPO, OCT. 24 AND 25,

WASHINGTON, D.C.

No fee for admission. Contact: Robert E. Harar, National Trade Productions, Inc., 9301 Annapolis Rd., Suite 104, Lanham, MD 20801 (301) 459-1815.

IWP FALL SYMPOSIUM, OCT. 24-26, ST. LOUIS.

The International Word Processing Association's annual conference and exhibition. Panels, sessions, and workshops are to be held on a variety of topics relating to word processing management and related information systems. \$15 for nonmembers. Contact: IWP Membership Services, Maryland Road, Willow Grove, PA 19090 (215) 657-3220.

CPEUG 78, OCT. 24-27, BOSTON.

The 14th annual meeting of the Computer Performance Evaluation Users Group. The theme is to be efficient management of the dp life cycle. There will be a panel on the President's Federal DP Reorganization Project. Contact: Carol B. Wilson, Bldg. 225, Room A-265, National Bureau of Standards, Washington, DC 20234 (301) 921-3485.

NOV.

THIRD ANNUAL CONFERENCE ON DISTRIBUTED DATA PROCESSING, NOV. 5-8, NEW ORLEANS.

The focus is to be on applications. Contact: John Breyer, International Data Corp., 214 Third Ave., Waltham, MA 02254.

FIFTH ANNUAL COMPUTER SECURITY CONFERENCE AND EXPO, NOV. 6-8, NEW YORK.

Conference chairman is Dick Brandon. Featured speakers include Willis H. Ware, Donn B. Parker, and Jerry Fitzgerald. Contact: Barbara H. Shimek, Computer Security Institute, Five Kane Industrial Drive, Hudson, MA 01749 (617) 562-7311.

MINI/MICRO CONFERENCE AND EXPO, NOV. 7-9, HOUSTON.

Contact: Robert D. Rankin, Managing Director, Mini/Micro Conference and Exposition, 5528 E. La Palma Ave., Suite 1, Anaheim, CA 92807.

COMPSAC 78, NOV. 13-16, CHICAGO.

Contact: Wallace A. Depp, executive director, Processor and Computer Software Systems Div., Bell Laboratories, Naperville, IL 60540 (312) 680-2111.

INTERFACE WEST 78, NOV. 14-16, LOS ANGELES.

Three conference programs will run concurrently: Small Business Systems, Data Communications, and Microcomputer Design and Application. Contact: Interface West, Inc., 160 Speen St., Framingham, MA 01701 (800) 225-4620 or (617) 879-4502.

QI Corporation Leader in Microcomputer Systems

- In 1972, QI Corporation developed, manufactured and delivered the world's first microcomputer system to Litton, a division of Litton Industries.
- QI Corporation was the first to introduce microcomputer systems with flexible diskette drives for external storage, which are now becoming the industry standard.
- QI was the first to make available on a low-cost microcomputer system the powerful PL/M programming language used on the far more expensive IBM 370 systems.
- QI Corporation set a fundamental new trend in the computer industry by introducing the multifunction microcomputer system, which cost-effectively replaces a wide variety of equipment including word-processing machines, accounting machines, desk-top programmable scientific calculators, and business equipment.
- In 1977, QI delivered the world's first computer system utilizing magnetic bubble memory technology to the headquarters of the National Aeronautics and Space Administration.

Look to QI Corporation for the
next major advance in microcomputer systems

SHERLOCK

“Holmes, can't you stop this wave of DOS sorting thefts?”

“No, Watson, I leave that to the chaps at SyncSort.”

Call (201) 568-9700.

It's the Scotland Yard of sorting.

OVERSEAS REPRESENTATIVES —

Brussels: CAP/GEMINI Belgium
Dusseldorf: CAP/GEMINI GmbH
Geneva: CAP/GEMINI Switzerland
Hague: CAP-GEMINI/PANDATA
Johannesburg: Computing Benefits Ltd.
London: GEMINI Ltd.
Melbourne: Shell Oil Co. of Australia
Milan: SYNTAX
Paris: CAP/SOGETI PRODUCTS
Stockholm: BRA
Tel Aviv: ADVANCED TECHNOLOGY, Ltd.
Vienna: CAP/GEMINI GmbH



COMPUTER SYSTEMS Inc. 560 Sylvan Ave., Englewood Cliffs, N.J. 07632

Purely as a public service, we at the Yard issue the following all points bulletin for DOS and DOS/VS users:

WARNING

Professor Moriarty, Sherlock Holmes' long-time arch-enemy, is *not* dead as previously reported. He is thought to be alive and well and living in a DOS/VS computer center. He is said to be cleverly disguised as a down-at-the-heels DOS sort program.

Moriarty's *modus operandi* is simple but effective. Under the guise of performing sorting jobs "well enough," he actually "skims the cream" off the users' True CPU Time, Elapsed Time and SIOs on every sorting run.

By the time the worried manager and staff become aware that their resources are disappearing mysteriously, so is Moriarty. Generally in a hansom cab, under cover of a pea-soup fog.

If you suspect someone has been filling his pockets with your resources, call the people at SyncSort. They'll dispatch one of their "Moriarty Detectors"—a systems engineer specially trained to sniff out bad sorts.

A couple of simple benchmarks will show you where your computer resources have been going:

SyncSort DOS vs. IBM's SM1-5746.

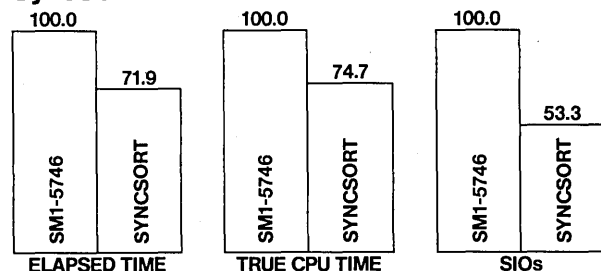

SyncSort DOS vs. IBM's SM2-5746.

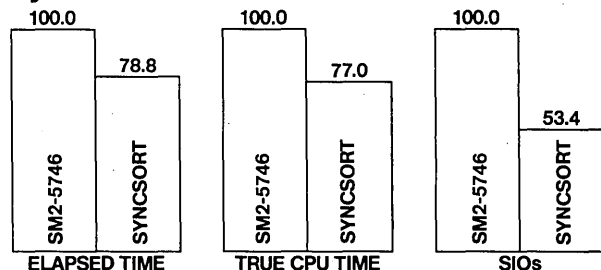

The next step is to bring in Inspector SyncSort on a round-the-clock basis. It's the only way, sorting experts say, to make your operation permanently "Moriarty Proof."

Your investment in Tektronix graphics continues to grow.

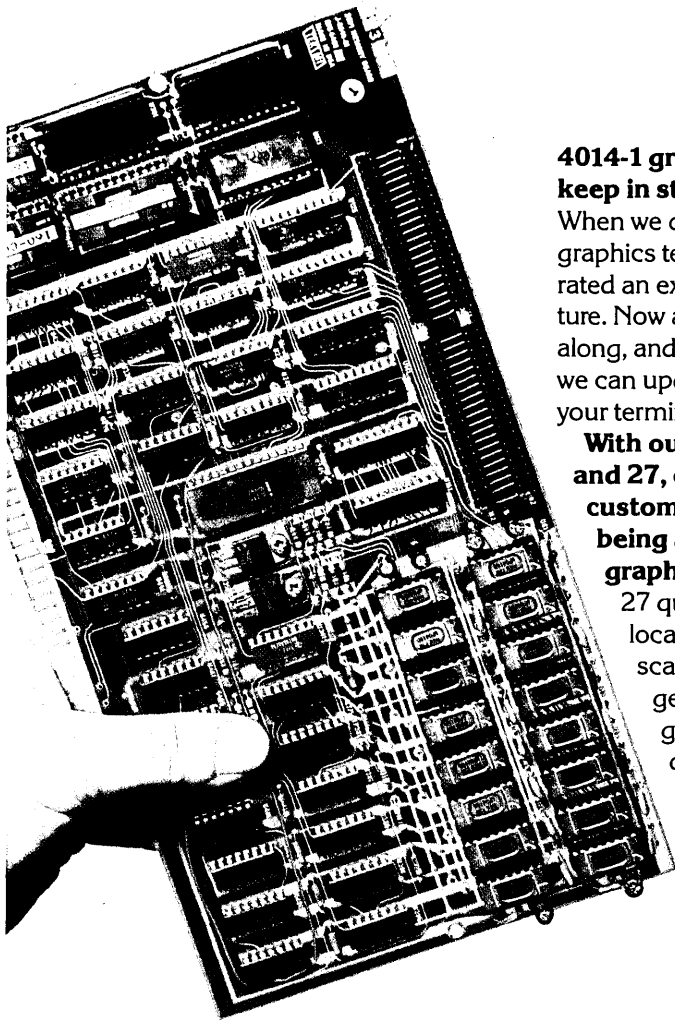

4014-1 graphics: designed to keep in step with your needs.

When we designed our 19" graphics terminals, we incorporated an expandable bus structure. Now as better ideas come along, and as your needs change, we can update—not outdate—your terminal.

With our new Options 40, 41 and 27, even our first 4014-1 customers can count on being at the forefront of graphics.

Options 40, 41 and 27 quickly plug in to provide local graphics memory, scaling, 1° rotation, circle generation, relative graphics, clipping, user definable stroke characters, symbol positioning, and much more.

Minimize time and transmission costs.

Save all or parts of displays in 28K RAM then recall them under computer control or with a single keystroke. Improve interactivity. Build your own special characters—off line.

Count on the 4014-1 to hold its value—even when values change.

Your present 4014-1 can be quickly field-upgraded with these options. And because they're from Tektronix, you're assured of exceptional reliability and service. Call your Tektronix Sales Engineer for full details.

Tektronix, Inc.
Information Display Group
P.O. Box 500
Beaverton, Oregon 97077
Tektronix Datatek NV
P.O. Box 159
Badhoevedorp, The Netherlands

Copyright © 1977, Tektronix, Inc.
All rights reserved

Tektronix
COMMITTED TO EXCELLENCE

CIRCLE 86 ON READER CARD

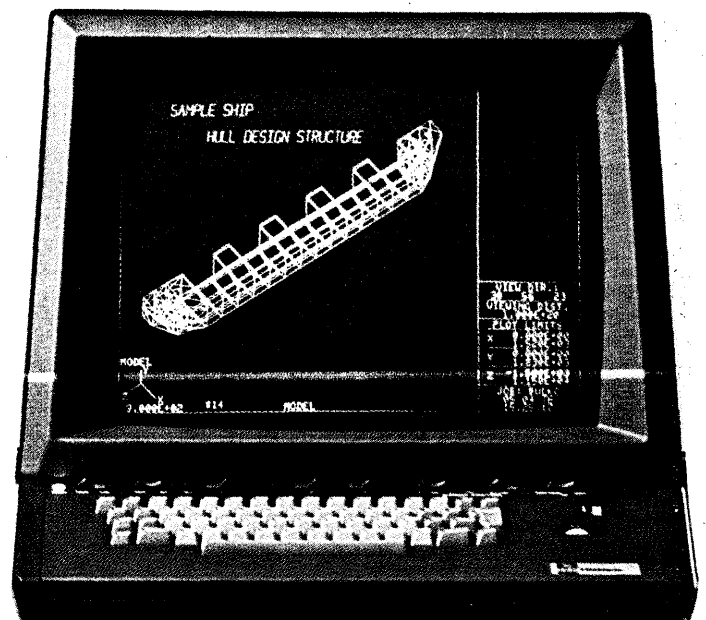

If you own one of these

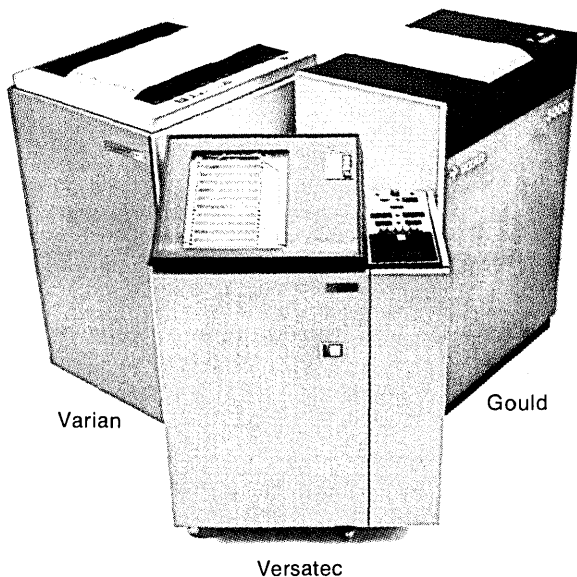

get sensitive.

You pay plenty for electrostatic paper.
You should know about our new paper
that makes brighter images and costs less.
Try a roll free. Come with the
Sensitive Paper People.



sensitivity coupon

Send one free roll or fanfold to fit:
 Gould, Varian, Versatec

Annual Usage: _____ rolls Paper Number: _____

Name _____ Phone _____

Firm _____

Address _____

City _____ State _____ Zip _____

Mail to Coated Products Division, Graphic Controls Corporation,
P.O. Box 1309, Buffalo, NY 14240

Or call toll free 800-828-7978.
(In New York State, call 716-847-7500.)

D-E-9

CIRCLE 182 ON READER CARD

CALENDAR

ELEVENTH ANNUAL MICROPROGRAMMING WORKSHOP, NOV. 19-21, PACIFIC GROVE, CALIF.

The workshop is to be a forum for discussion and comparison of design techniques for firmware and supporting hardware. Contact: Dr. Alice C. Parker, MICRO-11 program chair, Electrical Engineering Dept., Carnegie-Mellon Univ., Pittsburgh, PA 15213 (412) 578-2472.

EUROPEAN COMMUNITIES SYMPOSIUM ON COMPUTER AIDED DESIGN OF DIGITAL ELECTRONIC CIRCUITS AND SYSTEMS, NOV. 27-29, BRUSSELS.

Speakers have been invited from Europe, Japan, and the United States. Contact: Keness Belgium Congress S.A., Rue de l'Industrie, 17, 1040 Brussels (Belgium).

NINTH ANNUAL CANADIAN COMPUTER SHOW, NOV. 28-30, TORONTO.

Contact: Marion Hart, CIPS (Canadian Information Processing Society), 212 King St., W., Suite 214, Toronto, Ontario M5H 1K5.

DEC.

ANNUAL ACM CONFERENCE, DEC. 4-6, WASHINGTON, D.C.

Keynote speaker will be Dr. Richard C. Atkinson, director of the National Science Foundation. Contact: Dr. Richard Austing, Dept. of Computer Science, Univ. of Maryland, College Park, MD 20740 (301) 454-2004.

MIDCON 78, DEC. 12-14, DALLAS.

High technology electronics show and convention. Contact: Hal Copeland, The Hal Copeland Co., 528 Meadows Bldg., Dallas, TX 75206 (214) 361-8788.

COMPUTER NETWORKING SYMPOSIUM, DEC. 13, GAITHERSBURG, MD.

To be held at the National Bureau of Standards. Papers presented will concern both practical and research experiences with computer and communications networks. Contact: Dr. George Cowan, Computer Sciences Corp., 6565 Arlington Blvd. Falls Church, VA 22046.

WORKSHOP ON SOFTWARE TESTING AND TEST DOCUMENTATION, DEC. 18-20, FT. LAUDERDALE.

Contact: Dr. Edward F. Miller, Jr., Software Research Associates, P.O. Box 2432, San Francisco, CA 94126.

JAN. 1979

JAN. 1979 PACIFIC TELECOMMUNICATIONS CONFERENCE, JANUARY 8 AND 9, HONOLULU.

Papers presented will cover telecommunications technology, communications policy, and the economics of telecommunications. Papers on multidisciplinary topics will be emphasized. Participation of attendees from developing countries in the Pacific is encouraged. Contact: PTC '79, Social Science Research Institute,

Univ. of Hawaii, 2424 Maile Way #704, Honolulu, HI 96822 (808) 948-7879.

U.S./AFRICA TELECOMMUNICATIONS CONFERENCE AND EXHIBIT, JANUARY 17-19, NAIROBI, KENYA.

Contact: Electronic Industries Assn., Communications Div., 2001 Eye St. N.W., Washington, DC, 20006 or call John Sodolski at (201) 457-4934.

COMPUTER LAW ASSOCIATION MEETING, JANUARY 25 AND 26, LOS ANGELES.

Contact: Michael Yourshaw, 1776 K St. N.W., Washington, DC 20006 (202) 857-5079.

COMMUNICATION NETWORKS, JANUARY 30-FEBRUARY 1, WASHINGTON, D.C.

Designed to "bring together, for the first time, leading communications network users, consultants, vendors and regulatory officials and combine them into one coherent forum where all of the issues can be discussed and analyzed." Chairman is Richard E. Wiley, former FCC Commissioner. Contact The Conference Company, 60 Austin St., Newton, MA 02160 (617) 964-4550.

FEB.

INTELCOM 79, FEBRUARY 26-MARCH 2, DALLAS.

Over 10,000 attendees are expected from 100 countries. The theme of the exposition is "Change . . . the New Definition of International Telecommunications." Some subjects to be covered in the technical program include: broadcasting, data system architecture, teleprocessing, digital transmission and switching, fiber optics, network and facility planning and management, shared systems, and teleconferencing. Contact Horizon House International, 610 Washington St., Dedham, MA 02026 (617) 326-8220 or (800) 225-9977. In England: 25 Victoria St., London sw1 222-0466.

CALLS FOR PAPERS

Papers on a wide variety of applications and systems are being solicited for the First International Symposium on Mini and Microcomputers in Control, to be held in San Diego Jan. 8-9, 1979. A 200-250 word abstract is due Oct. 1 to: The Secretary, Computers in Control Symposium, P.O. Box 2481, Anaheim, CA 92804 (714) 774-6144.

The theoretical, functional, administrative, political, and ethical aspects of urban data management are potential subjects for papers to be presented at the 7th European Symposium on Urban Data Management, to be held in the Netherlands April 23-27, 1979. Abstracts (in English or French) are due before Oct. 15 to: Professor Dr. M.J.M. Bogaerts, Thijssseweg 11, 2629 JA Delft, The Netherlands.

Theory and practice of control will be the subject of the 1979 Joint Automatic Control Conference, to be held June 17-20, 1979. Deadline for submission of abstracts is Oct. 1. Send to: Professor T.F. Edgar, program chairman, 1979 JACC, Dept. of Chemical Engineering, Univ. of Texas, Austin, TX 79712.

Papers are now being accepted for the Ninth International Symposium on Fault-Tolerant Computing, to be held in Madison, Wis., June 20-22, 1979. Four copies of an abstract, maximum 200 words, may be sent to: Program Chairman, Gerald M. Masson, Dept. of Electrical Engineering, Johns Hopkins Univ., Baltimore, MD 21218. Deadline is Nov. 1. *

To owners of these:

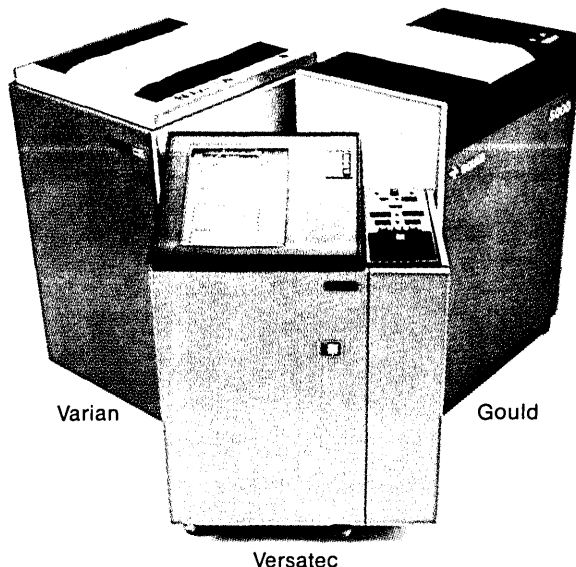

Meet your most complete paper source

Standard white, and now exclusive easy-reading green. Add optional perforated rolls and numbered pages. And you've found today's most complete source for electrostatic paper and toner.



free roll

Send free roll or fanfold pack of eye-ease green to fit: Gould, Varian, Versatec

Annual Usage: _____ rolls New Customer _____

Paper Number _____

Name _____ Phone _____

Firm _____

Address _____

City _____ State _____ Zip _____

Mail to Coated Products Division, Graphic Controls Corporation, P.O. Box 1309, Buffalo, NY 14240

Or call toll free 800-828-7978.

(in New York State call 716-847-7500)

D-SSG-9

3032 & 3033 buyers only.

Your decision to buy one of these systems represents a significant investment. Do not jeopardize its operation.

The Achilles Tendon. Proper cooling is mandatory on the 3032 & 3033. They are cooled internally and the flow of liquid coolant at critical temperatures must be maintained constantly. The slightest interruption will result in very costly downtime.

The Solution. The C.D.U. Spacemaker by Liebert has been developed to meet these exacting liquid cooling needs. When compared, the application and design limitations of alternate methods makes them needless gambles.

No one can match the 100-200% redundancy built into the Spacemaker. The automatic switchover. The precision and reliability of solid state components.

The C.D.U. Spacemaker is designed to guarantee a failsafe system.

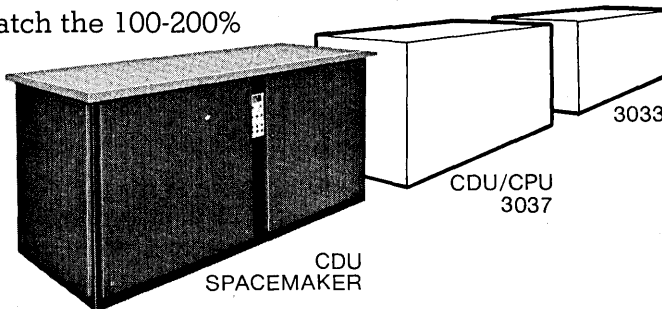

And more. Operating costs make this a system you must consider.

Look to Liebert for experience in mainframe cooling. Get the facts. Call the Sales Department at 614-888-0246. Or use the reader service number.



FIRST... and growing

Liebert Corporation

1050 DEARBORN DRIVE, P.O. BOX 29186, COLUMBUS, OHIO 43229
PHONE: 614-888-0246, TELEX 246-655



An intelligent solution to image and graphic display problems Higher performance + lower price = optimum systems by Aydin Controls

THE NEW AYDIN CONTROLS Model 5216 Display Computer is the intelligent solution to your graphics and image processing display requirements. Why be locked into the limited capability "packaged terminal" approach now prevalent in the industry? The Model 5216 consists of a family of functional hardware and software modules from which you may configure a display system for stand-alone operation or for integration into your system. Simply select those modules which are consistent with your application. The Model 5216 provides multi-processing capability and multiple buss architecture for separate input/output, display processing, and display refresh functions to enhance system performance and flexibility. Whether you need a low-end alpha/graphic color terminal or a sophisticated multi-image, high resolution image processing display system (or anything in between), the Model 5216 display family is your answer.

SALIENT FEATURES

- High-performance multi-processor buss architecture
- Pixel or graphic DMA block mode data transfer (800 nano-seconds per 16-bit pixel)
- Multiple pixels per word
- Wide selection of display formats including 512 x 512 x 16, 1024 x 1024 x 16, and up to 1024 x 512 x 16 bits per pixel at 60Hz refresh rate
- Video pro-

- cessing through look-up table (RAM) at bit rates to over 40MHz
- Built-in vector and circle generation
- Four sizes of alpha characters
- High speed hardware math
- Both parallel and serial peripheral interfaces available
- User programmable

STANDARD HARDWARE MODULES

- Processor Module (16-bit)
- Processor Expansion Memory (up to 1 megabyte of PROM or RAM)
- Memory Buss Controller (sync and control)
- CPU I/O Module (DMA to host)
- Video Modules (several types available)
- Memory Modules (display formats from 256 x 256 to 1024 x 1024 x 16)
- Mass Storage Controllers (floppy disk and magnetic tape)
- Zoom Controller (2X, 4X, 8X and 16X)
- Hardware Math Modules (including vector/circle)
- Alphanumeric Channel Module (80 x 48 format, 256 unique symbols, 8 colors)

STANDARD SOFTWARE MODULES

- AYDOS Operating Systems
- Software Support Modules
- AYGRAPH 2D or 3D Graphics Modules
- AYGRAPH Image Processing Modules
- Emulation Modules

Configure your system from the Model 5216 family of hardware and Software Modules and prove to yourself the cost/performance advantages of AYDIN CONTROLS for your application.

AYDIN  **CONTROLS**

444 Commerce Drive • Fort Washington, Pa. 19084

Phone (215) 622-7300 • TWX (510) 664-0518

One source for all your CRT display requirements

CIRCLE 19 ON READER CARD

a complete color graphic computer



with keyboard

\$5995*

Chromatics has done it again. It's getting to be a habit for Chromatics to be first with attractive pricing and technological advancement in high resolution color graphic computers. Now, you have a choice of four models and three screen sizes, starting at a low \$5,995. Talk about choices! The Chromatics CG line of single package color graphic computers includes 13", 15" and 19" color screen sizes... 512 x 256 and 512 x 512 resolution... Z-80 CPU with full memory and I/O structure... floppy disks... X-Y digitizer tablet... light pen. With them you have the advantages of a stand alone operation... a software development system with CPU Operating System, Text Editor, Assembler and BASIC... keyboard accessible graphics design with vector, circle, arc, rectangle, create and overlay modes... variable size alphanumeric with graphics character options... all with eight colors and individual dot addressability. Contact your nearest Chromatics representative for the latest in quality, smart color graphic computers.

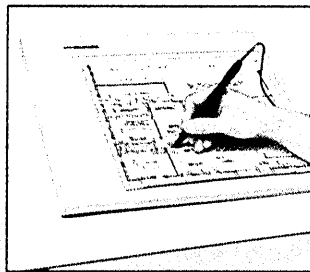

X-Y Digitizer Tablet
Need a simple method to digitize graphs or select menus? Chromatics' new X-Y digitizer tablet makes quick work of both tasks. Enter your graphics data in color in record time. Sign your name if you like to your own color drawing!

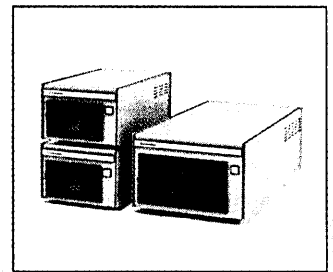

Floppy Disks
Having a hard time getting a complete system from one vendor? Add Chromatics' single or dual Minifloppy[®] or Regular Floppy Disks to your CG Series Color Graphic Computers and have a complete development system. They're already interfaced and ready to go!

SALES REPRESENTATIVES

Ala.: Huntsville
Col-Ins-Co. 800/327-6600
Ariz.: Phoenix
Thorson Co. 602/956-5300
Calif.: Irvine
Thorson Co. 714/557-4460
Calif.: Los Angeles
Thorson Co. 213/476-1241
Calif.: Mountain View
Thorson Co. 415/964-9300
Calif.: San Diego
Thorson Co. 714/292-8525
Calif.: Santa Barbara
Thorson Co. 805/964-8751
Colo.: Denver
Thorson Co. 303/759-0809
Fla.: Orlando
Col-Ins-Co. 305/423-7615 (local calls) 800/432-4480 (inside Fla.) 800/327-6600 (outside Fla.)
Ga.: Atlanta
Col-Ins-Co. 800/327-6600
Hi.: Honolulu
Thorson Co. 808/524-8633
La.: Baton Rouge
Col-Ins-Co. 800/327-6600
Mass.: Framingham
Bartlett Assoc. 617/879-7530
Md.: Bethesda
Bartlett Assoc. 301/656-3061
Mich.: Detroit
WKM Assoc. 313/588-2300

N. Mex.: Albuquerque
Thorson Co. 505/265-5655
N.Y.: White Plains
Bartlett Assoc. 914/949-6476
N.C.: Winston-Salem
Col-Ins-Co. 800/327-6600
Ohio: Cleveland
WKM Assoc. 216/267-0445
Ohio: Dayton
WKM Assoc. 513/434-7500
Or.: Portland
Thorson Co. 503/620-5800
Pa.: Pittsburgh
WKM Assoc. 412/892-2953
Pa.: Wayne
Bartlett Assoc. 215/688-7325
Tex.: Austin
Thorson Co. 512/451-7527
Tex.: Dallas
Thorson Co. 214/233-5744
Tex.: Houston
Thorson Co. 713/771-3504
Utah: Salt Lake City
Thorson Co. 801/973-7969
Wash.: Seattle
Thorson Co. 206/455-9180
Europe & Near East
Techexport, Inc. 617/661-9424
Japan & Far East
Computers International
213/382-1107

*Model CG-1998A—
512 x 256, 19" screen,
Domestic, Continental
USA Price. Delivery:
30 to 120 days, de-
pending on model.

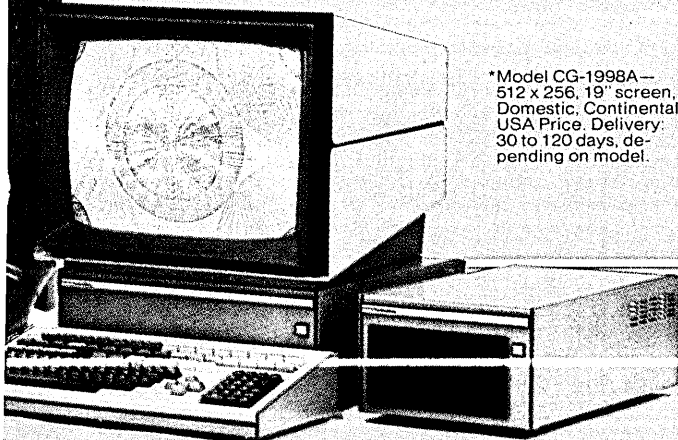

Chromatics™

NEW DIMENSIONS IN COLOR GRAPHICS

Call your local area representative or contact a factory Applications Engineer at Chromatics, Inc., 3923 Oakcliff Industrial Court, Atlanta, GA 30340. Phone 404/447-8797. TWX 810/766-4516.

Realist

To have an intelligent system, the reader has to make sense.

Systems design is your key to a smart microfilm reader buy. But there are a lot of readers available on the market. How do you choose?

At Realist, we give you the best options in readers because we consider systems applications right from square one.

Front projection. Rear projection. Portability. We'll help you analyze your needs, so you can make a sensible decision. Because to make intelligent choices, you need intelligent alternatives.

Shown:
REALIST VANTAGE. The most functionally advanced COM reader on the market.

REALIST EXECUTIVE & AGENT. The world's only true portables. Each features a spacious briefcase with built-in fiche panels.

REALIST VALIANT. The lowest cost front projection reader of all major brands.



See the full line of Realist microform readers at INFO 78, Chicago. Booth #507.



Anybody will sell you a reader. Realist will provide you with a great deal more: consultation on your microform system at no cost. For further information on the Realist line, call toll free: 1-800-558-8577.



REALIST

Realist, Inc.
Micrographics Division
N93 W16288 Megal Drive
Menomonee Falls, WI 53051
Realist International S.A.
3, Rue Armagis
78100 Saint-Germain-en-Laye, France

The 8500M Microprocessor Based Intelligent Graphic Computer Terminal

A New Era in Raster Graphics

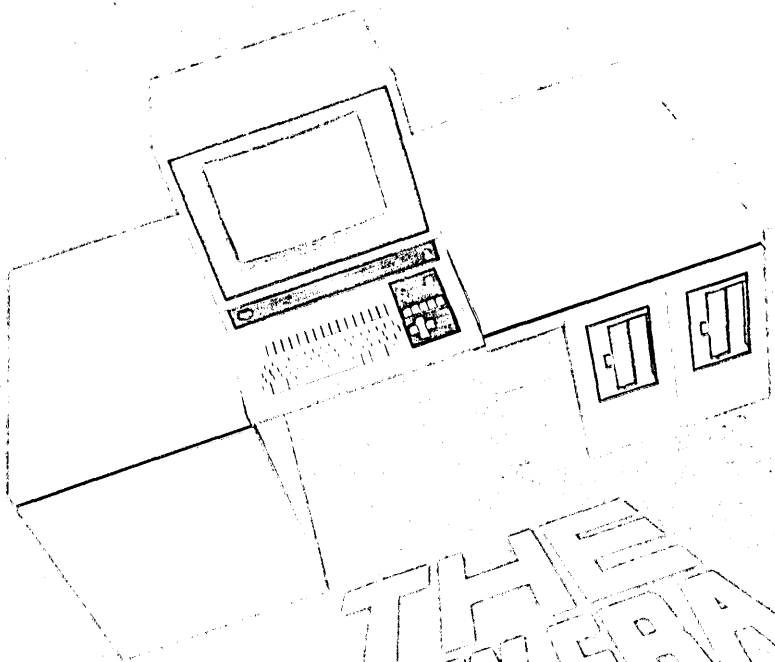

- On-line raster-based graphics capabilities with:
 - On-line 3-D and 2-D computer-aided design
 - On-line 2-D and 3-D textured graphics
 - On-line drawing and editing
 - On-line interactive word processing capabilities
- Simultaneous full-page, scrollable multiple graphics view processing and display
- 4096 x 4096 character resolution
- High resolution raster scan presentation

Typical applications include:

- Image acquisition and analysis
- Computer-aided design
- Textured image processing
- Industrial process control
- Flow control modeling
- Air, marine, and ground traffic control
- System simulation
- Verification
- Simplified presentation of complex technical drawings and data
- High speed bit graphics storage and display identification systems

THE NEW ERA IN RASTER GRAPHICS

Call or write for descriptive literature

detailing all outstanding features, options, specifications and prices.



PRINCETON ELECTRONIC PRODUCTS, INC.

P.O. Box 1001 • North Brunswick, N.J. 08902 • (201) 297-4448 • Telex 740-480-3582

SAS can't give you a bigger staff...



..but we can make the one you have more productive.

It would be nice if you had two DP staffs. One for the regular work, and one for the special requests. But chances are you don't. So you need SAS.

SAS puts all the data analysis tools you need for most jobs into one software system. And your staff won't have to master a complicated language to use it. With a few simple commands SAS handles

retrieval, data management, statistical analysis and report writing.

That means one person with SAS can handle those special requests in hours or minutes ... even jobs that might take days using conventional methods.

Users are now proving that it works at more than 500 IBM 360/370 OS computer sites. Those users have named SAS

to the Datapro Honor Roll for the second consecutive year. And SAS costs less than you might think.

Write or call for a free booklet. We can't give you more people ... but we can help you get the most out of the ones you have.

SAS SAS Institute Inc.
P.O. Box 10066
Raleigh, NC 27605
919/834-4381



How do you explain a brownout to a computer?

The same way you explain the other unpredictable line anomalies found in today's commercial power. You don't.

There is an answer, however, to this rapidly growing problem.

A Kato motor-generator set. It delivers a constant supply of clean, accurate power so you can ride out sudden voltage fluctuations that often shut down systems needlessly. In fact, you can continue operations indefinitely, despite voltage reductions of 20% or more.

And because an M-G set is the only method that provides total load isolation, you're fully protected against harmful spikes that result in costly, often untraceable computing errors.

Kato Engineered M-G sets do the job with energy saving efficiency and low maintenance requirements.

They're rugged, too. Our conservatively designed units withstand severe overloads that would destroy a solid-state device in seconds.

Ask us about the cost-advantages of using a Kato motor-generator set in your operation. We'll draw on our 50 years of experience in meeting your power conversion needs.

Call Kato Engineering Company, Mankato, Minnesota 56001. (507) 625-4011.

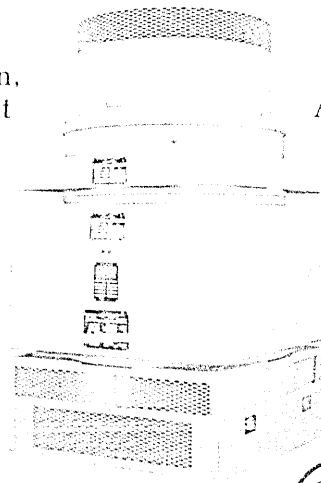

KATO
Engineering COMPANY



“New from Control Data... ...the complete line of miniperipherals for the Series/1.”

“If you’ve already included a Series/1 in your ddp strategy, you should know that you can get even higher performance with our new Certainty Series of miniperipherals. We engineered it around the Series/1 architecture, retaining the important cycle steal feature. And the Certainty Series is available today. A complete line of competitively-priced products to help you get even more out of your Series/1.

“Our display stations for example. No longer must you use expensive video cabling. Or restrict their location to within 500 feet of the cpu. Certainty display stations use low cost digital cabling. So you can put your terminals where your people are—up to 4,000 feet from the cpu.

“Or our Certainty line printer that gives you clean, crisp printing at 720 lpm. It can also cut your paper usage by 30% when you use its compressed pitch option.

“And now you can add up to 240 Mbytes of removable storage with our Storage Module Drive. Now its popular format attaches to your Series/1.

“Controllers? You won’t see any in our product line. Because we’ve incorporated all controllers and interface logic into our hardware. All of these products are ready right now to be plugged into the Series/1.

“And anyone who buys our miniperipherals gets our commitment to remain current with all releases of IBM operating software. Control Data knows how important support is. More than 4,800 Customer Engineers in our worldwide maintenance organization support our products. Our Education Company can train your people. Our Professional Services Division can help you program your applications. Even financing for your purchase is available through Control Data’s financial subsidiary, Commercial Credit.

“Let us show you how our Certainty Series makes your Series/1 strategy even sounder. For data sheets and more information, call today. 612/482-4379.”

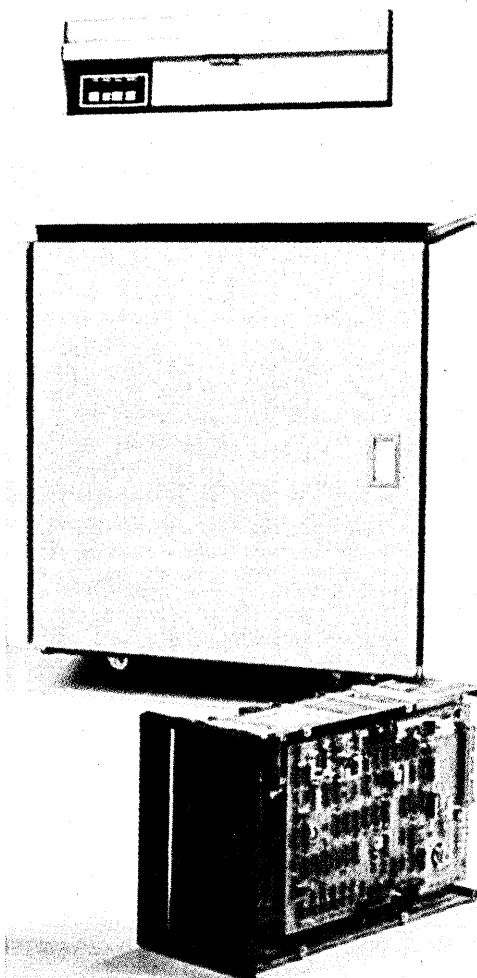

Larry Eaton, General Sales Manager
Miniperipheral/Terminals Division
Control Data Corporation

GD CONTROL DATA
CORPORATION

More than a computer company

CIRCLE 23 ON READER CARD

Does its broad line make Centronics' matrix printer family the best?

NO. Even though the Centronics 700 series is a continually expanding printer family — currently 9 models and a range of print speeds from 60 to 180 cps — there's

much more to it than just breadth of line. For example, there's a choice of 6 different types of forms handling capability; choice of uni- and bi-directional operation; and choice of 80 and 132-column formats. Why so much choice? It comes from the simple, highly flexible modular 700 series design that delivers superior reliability, exceptional parts commonality — and competitive prices.

And like all Centronics printers, the 700 series is fully supported by the largest worldwide service organization of any printer company. For complete 700 series information write or call today. Centronics Data Computer Corp., Hudson, NH 03051, Tel. (603) 883-0111.

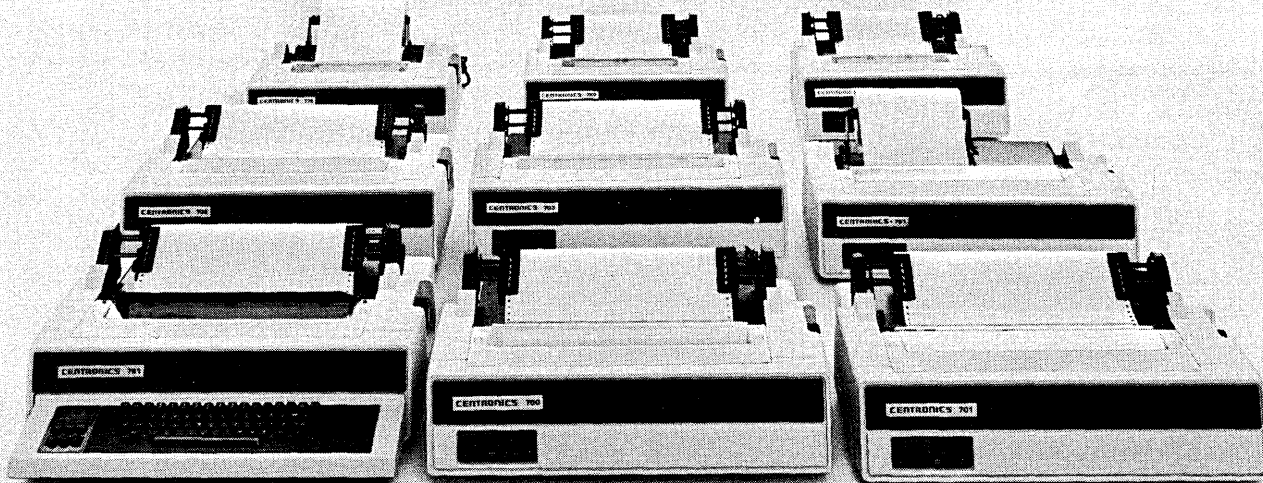

CENTRONICS® PRINTERS
Simply Better

LETTERS

RIVAL DINOSAUR

I thoroughly enjoyed the article "(Mis)use of DP in Government Agencies" (July, p. 147).

I am an employee of county government, in the human services area, so I am in a position to observe some of the impact of federal/state dp operations on the delivery of human services. The brachiosaurus of federal/state dp at the local level is the social services-welfare dp systems. There currently exists an almost unbelievable labyrinth of disconnected systems and subsystems which are poorly designed, expensively maintained and almost impossible to use. This moribund beast must be fed an inordinate amount of paper by human service professionals. This wasteful activity is extremely frustrating and demoralizing and ultimately detracts from their primary jobs—delivery of services to clients who need them.

Fortunately there are forward-thinking people at the federal and state levels who are becoming increasingly sensitive to the cost of the misuse of data processing in the delivery of human services.

I wholeheartedly agree with the suggestions of the article that the dp resource can be managed competently and can assist in the administration of human services. I hope that their recommendations will be taken seriously at the national level.

WILLIAM J. SWANSTROM, chairman
Data Processing Users Committee
Olmsted County, Rochester, Minnesota

ERRORS AND INTERPRETATIONS

I found the Forum column entitled "HUH?" (July, p. 229) an insult to the programming and systems analyst professions. The "bugs" and "Garble-De-Gook" of which Mr. Rowlett complains do not exist in a system that is up and running if the analyst has done his job.

JOHN DATSCHEFSKI
Systems Analyst
Mueller, Sieracki, Kaun & Co.
Certified Public Accountants
Elgin, Illinois

I applaud Mr. Rowlett in his Forum on error messages. I have many times wished that error messages were more

specific when debugging a program. A lesson, I think, could be learned from APL which not only has a limited number of messages but flags the character which the compiler identifies as being in error.

In the future I hope to see an article suggesting ways to write more meaningful error messages so that the entire programming community can benefit. Either that or a large journalism course for all programmers everywhere.

BRUCE I. PAUL
Systems Programmer
National CSS, Inc.
Wilton, Connecticut

If Mr. Frank B. Rowlett, Jr. would have spent as much time with the Program-

ming Staff as he did on his article knocking programmers, his monumental problem might be solved.

There are a lot of good programmers who have to put up with people who *make assumptions and were wrong!*

STEVE LITTLE
Programmer
Kingsport, Tennessee

Clearly, Mr. Rowlett, you have a misconception. Program messages are indicators, not great American novels. Message length restrictions often require incomplete sentences and abbreviated words. Details of system functions and related messages are usually found in the system user's guides. Often, message



"You see, I was always afraid of getting an occupational disease . . ."



If you operate in a time-dependent business climate, your data network is an intimate part of your business. For you, data network failure could stop operations in their tracks. And, if your company's growing, chances are the data network is growing too, adding more elements that could fail. Usually at the worst time. An extremely risky business relationship.

Take the risk out of your data network relationships with an Intertel EMS-One Network Control System. The EMS-One guarantees uninterrupted data flow by continuously monitoring your network—while it's operating on-line—the way the autonomic nervous system monitors



A NEW PERSPECTIVE ON NETWORK CONTROL

Perspective . . . the ability to view relationships . . . relationships between your data network and your business operations.

the human body. EMS-One circuits overlay your data network and perform side-channel diagnostics on all lines and remote sites. They report back early warning symptoms of impending troubles before they occur. The EMS-One does off-line testing, too, when detailed measurements of network parameters are required. Should the unexpected happen, the EMS-One quickly locates the network or remote site fault, isolates it, and provides the means to bypass it. Control is all from your central site: downtime is reduced from hours to seconds.

EMS-One systems are easy to use and understand. Operations are virtually

automatic: tests and conditions are reported in plain English on a visual display and on a hard-copy record. If there's trouble, the EMS-One provides the interfacing for a rapid and smooth transition to backup operations. Long-term cost savings, too, because the modems used in the EMS-One system let you run data on unconditioned lines.

Choose the only third-generation Network Control System—the EMS-One. The Network Control System with upward compatibility that grows as your network and business grow. From simple multipoint networks to sophisticated multi-line networks with interactive distributed data processing.

Intertel is the pioneer and developer of Network Control Systems for data communications networks—three generations worth. We have a broad perspective on Network Control—knowledge gained from an installed base of over 200 Intertel Network Control Systems. Let us help you get a new perspective on your network.

intertel

#1 in Network Control

6 Vine Brook Park
Burlington, Massachusetts 01803
(617)273-0950 member of IDCMA

The Printer Store

Digital Associates Corporation

PDP-11 Users: Save \$9100 on our 600 LPM printer replacement.

For \$9100 less than DEC's 600 LPM drum printer you can now get Digital Associates' 600 LPM drum printer (DAC-2260) for your PDP-11. The DAC-2260 is a direct replacement for DEC's LP 11-YA and plug compatible with both PDP-8 and PDP-11 CPU's. Similar savings are available with our higher speed 900 and 1250 LPM printers, both plug-to-plug replacements, designed for higher performance minicomputer applications.

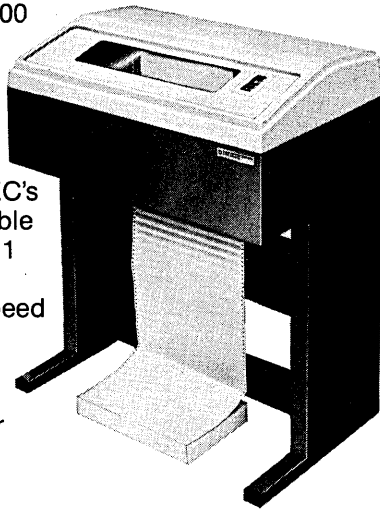

Or, switch to ChainTrain quality.

The DAC CT-6644 is a 600 LPM ChainTrain printer that is a direct replacement for the LP 11-YA. It upgrades your printing to letter quality, and saves you \$8500 against DEC's 600 LPM drum printer, LP 11-YA. It comes with PDP-11 interface, installation and maintenance. All our drum and ChainTrain printers can interface as well to the larger DEC-20.

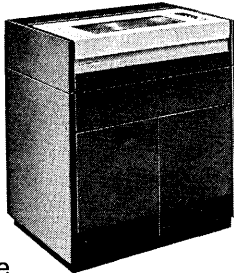

Save on printers for any mini-computer system. We offer line printers that are compatible with IBM Series/1 and System/3, Data General (with DMA), Hewlett-Packard (including 3000 Series) and most other minicomputer systems. All offer tremendous savings and you can choose from ChainTrain, drum, band, Chara-band or dot matrix technology. Digital Associates' Printer Store is the alternative source for minicomputer line printer systems with installation and complete maintenance service available on a nationwide basis.

Digital Associates Corporation, 1039 E. Main St., Stamford, CT 06902
Call Toll Free 800-243-9054

LETTERS

length and content is defined by the analyst and user long before the programmer even sees the specification. To conclude that programmers, as a group, are incapable of correctly using the English language based on a program message you "ran across" is irresponsible.

D.C. FURGESON
Rockwell International Corp.
Identification & Control Systems
Anaheim, California

DOOM DENIED

While it goes against the grain to disagree with a Fellow of the Association of Computer Programmers and Analysts, I really must take exception to Portia Isaacson's dire predictions for the future of systems analysis as a profession ("Personal Computing," July, p. 218).

The same sort of doom was envisioned for the business programmer more than 10 years ago when software products like payroll and inventory packages started appearing. Yet, today there are more of this supposedly extinct species alive and kicking than ever before.

The statement, "when the computer becomes a home appliance, having a degree in computer science will be like having a degree in refrigerator science," shows a lack of understanding of the place of the professional in our society. Most people can use a needle and thread, a pair of scissors, and even a typewriter. I wonder how many of them make their own clothes, cut their own hair, or, heaven forbid, type their own memos?

The ACPA has never viewed its members as "practitioners of the black art" and so fearlessly awaits that dark day when "the kid down the street can program." Who knows, maybe the kid will be in the market for a good toy-soldier inventory system.

JULIE HUSHAK, CDP
North Central Regional Dir., ACPA
OCLC, Inc., Columbus, Ohio

LAST LAUGH

I really enjoyed "The Last of the First" by Aubrey Dahl (June, p. 145). A central processor "9 feet high, 10 feet wide, and 14 feet long" certainly seems strange today. I can just imagine our children in 1998 laughing at our IBM 3033s as they talk into their wristwatch-sized cpu's.

HARRY L. NAGEL, Ph.D.
Associate Professor of Quantitative
Analysis
St. John's University
Jamaica, New York

With SYSTEM 2000,[®] you get more than just a DBMS.

You also get

- Multiple DB/DC languages with integrated data dictionary
- Greater productivity in applications development
- Lower software maintenance costs
- Proven reliability & availability for complex applications
- Greatly improved use of your data resources
- A solid foundation for future systems

These are just a few of the special benefits of SYSTEM 2000—the most advanced data base management system on the market.



SYSTEM 2000 offers something else really unique—MRI Systems Corporation. A company which has been developing data base management systems for almost ten years. A company staffed with 200 highly skilled people. A company which believes in customer services, and stands behind its products.

Visit MRI in Austin, Texas. You'll see that with SYSTEM 2000, you get more than just a great DBMS—you get an entire company.

PROFESSIONAL
THE DATA BASE MANAGEMENT COMPANY
12675 Research Blvd., Austin, Texas 78759, (512) 258-5171



Corporate Address: 12675 Research Blvd., Austin, Texas 78759 • **U.S. Sales Offices:** Austin • Charlotte • Chicago • Denver • Huntsville • Los Angeles • New York • Portland • St. Louis • San Francisco • Washington, D.C. • **International Sales:** MRI Systems (Canada) Ltd. • Toronto • Ottawa • Digital Scientific Europe Limited (DSEL) • The Hague • London • Paris • SYNTAX • Milan • BRA • Stockholm • CJK Co. Ltd. • Tokyo • Entel/bermatica • Madrid • **Remote Computing Services:** Boeing Computer Services, Inc. (BCS) • CalData Systems, Inc. • Canada Systems Group • Cie Internationale de Services en Informatique (CISI) • Computel Systems, Ltd. • Computer Network Corporation (COMNET) • Computer Sciences Corporation (Infonet) • CYBERNET Services (CDC) • Datacrown, Ltd. • Franlab • General Electric Company Information Services • Industrial Life-Technical Services, Inc. (IST) • Information Systems Design, Inc. (ISD) • Litton Computer Services • Lowndes-Ajax Computer Service, Ltd. • Martin Marietta Data Systems • McDonnell Douglas Automation Company • Multiple Access Computer Group • Proprietary Computer Services, Inc. • Service in Information and Analysis (SIA) • Systems Dimensions, Ltd. (SDL) • Telesystems (Paris Telephone) • Tymshare • United Computing Systems, Inc. (UCS)

HOW THE FENWAL FIRE SUPPRESSION SYSTEM IN THIS AUTOMOTIVE COMPANY PAID FOR ITSELF IN ONLY 2 WEEKS.

At 9:03 on a Wednesday night, an electrical malfunction caused overheating, and smoke began rising in the west end of this company's computer room.

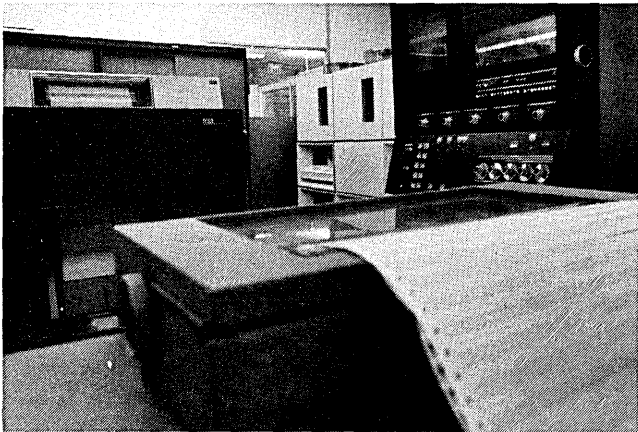

At 9:06, while the fire was still in the smoldering stage, the Fenwal Fire Suppression System automatically sensed this smoke and discharged its extinguishing agent (Halon 1301).

By 9:30 that same night, the smoke had cleared, employees had arrived and with the appropriate Fire Department clearance entered the computer room. Traces of Halon were present but there was no discomfort.

Close examination of the problem area revealed scorched and discolored internal wiring. Some relays would have to be replaced. But no other damage had occurred.

Even though the fire was inside the consoles, at the farthest point from the Fenwal discharge nozzles, the flames were snuffed out *dry*

and major damage or personnel injury was completely averted.

At 10:45 P.M. the Fenwal distributor who had installed the modular suppression system was called. By 5:30 A.M. it was re-charged and back in service.

This protection system had been installed just two weeks prior to the true incident described above.

It actually made the difference between a few hours of downtime and several weeks of expensive business interruption. The kind of interruption from which some businesses never really recover.

Fenwal has designed and installed more of these Fire Suppression Systems than any other manufacturer. And we make a full line of thermal, smoke and ultraviolet Detection Devices and Control Panels.

We have visual proof our Systems work in a variety of environments. Send for our film, "The Fireaters."

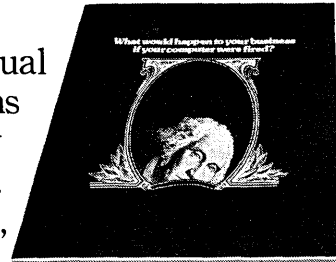

Or for a copy of our booklet on fire suppression. Write Fenwal Incorporated, Ashland, Mass. 01721. A division of Walter Kidde & Co., Inc., or call (617) 881-2000.

For installation and around-the-clock service, see our local distributors listed in the Yellow Pages under "Fire Protection."

FENWAL®

Nobody in the world has more experience in fire and explosion protection systems.



FACOM computers are made by Fujitsu, a company which puts the emphasis on systems.

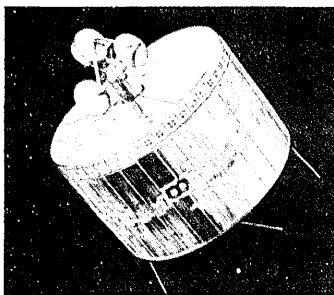

A computer is above all a system, a comprehensive processing tool integrating hardware, software and application technology. Computers are of course sold by many different companies. But few of these companies can offer you a full range of data processing tools — each not only specifically designed for optimal performance but also open-ended for integration into bigger systems.

Fujitsu is one company which can offer this. Fujitsu, Japan's leading computer maker, produces everything from one-LSI-chip microcomputers to the world's most powerful all-LSI computers, as well as a wide range of peripheral and terminal equipment.

FACOM computers are doing big jobs in business and government in many countries throughout the world. And in Japan, the world's second largest computer market, more FACOM computers are installed than any other brand. These powerful, reliable FACOM computers do just about anything. They put satellites into orbit, produce real-time color graphic displays of meteorological conditions, handle funds transfers in on-line systems tying in over 7,000 bank branches, and much, much more.

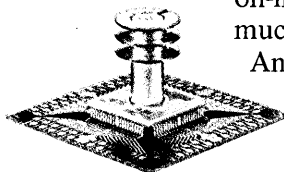

LSI with cooling fins

And all FACOM computers are totally integrated systems, systems in which state-of-the-art technology, powerful software and proven application programs are combined to give you a performance and reliability that can't be beat.

FUJITSU

CIRCLE 180 ON READER CARD

Fujitsu Limited: 6-1, Marunouchi 2-chome, Chiyoda-ku, Tokyo 100, Japan Telephone: 03-216-3211, Telex: J22833
Main Products • Switching Systems • Carrier & Radio Systems • Computer Systems • Data Communications Systems • Semiconductors • Electronic Components

LETTERS

ANALYSIS AND PARANOIA

The July "Personal Computing" (p. 218) by Dr. Portia Isaacson was very disconcerting.

The proliferation of computers in the field and their subsequent programming by the user could eventually lead to inefficient, undocumented, data-duplicating systems that will be more costly to the organization than a centralized professional department staffed by competent personnel. Perhaps the advent of interdepartment computers will lead the systems analyst to guide the user departments' work with in-house programmers. This might allow a reduction in data duplication, a general increase in the overall effectiveness of the systems, and a greater degree of integration with overall business goals.

The idea that a systems analyst, in order to insure his job security and also insure the purchase of the latest mainframe technology, is showing paranoia by not allowing computer purchases other than those approved through the dp department appears to be mirrored by Dr. Isaacson's own blatant interest in building a micro-computer store empire, through her part ownership of the same, to insure her own job security.

I dislike articles like this one because somewhere some head of a user

department, upon reading it, will get the idea he should go out to one of Dr. Isaacson's stores and buy a "word processing system" or "instrument" and become a "shadetree" systems analyst without consulting the people who would know the most about it in his company, namely the dp department personnel. This would be disastrous for the business as a whole.

Dr. Isaacson's attitude that the systems analyst is a dp Benedict Arnold whose loyalty lies mainly with the manufacturer, whose only interest is to change jobs, and who doesn't care about his current employer's interests, is an undeserved attack not only on systems analysis as a profession but also the entire computer profession as it now exists.

J.T. ROWAN, Jr.
Systems Analyst
Lee County Hospital
Opelika, Alabama

GAUGING GRAIN GROWTH

The article "Processing Satellite Data" (June, p. 117) presents an excellent overview of satellite remote sensing applications and digital image processing systems. However, the article does contain one major error which I feel obligated to correct. The Large Area Crop Inventory

Experiment (LACIE) is a joint project of the U.S. Department of Agriculture (USDA), the National Aeronautics and Space Administration (NASA), and the National Oceanic and Atmospheric Administration (NOAA). The U.S. Geological Survey (USGS) has no direct involvement in the LACIE Project.

The purpose of the joint LACIE Project is to determine the feasibility of using Landsat data and meteorological data to identify, measure, and estimate wheat production in the U.S. Great Plains and several foreign countries. The results of the past three years of the experiment are promising; however, several problems still must be resolved before Landsat data can be effectively used to forecast crop production on an operational basis.

One of these problems is the difficulty we experience in distinguishing between spring wheat and other spring grains such as barley, rye, oats, and rapeseed. This is caused partly by the similar growth cycle of these crops and partly by the broad spectral ranges of the present scanner sensors.

A more serious problem to any operational system is the timely delivery of corrected Landsat data. We currently obtain corrected and specially sampled data anywhere from 14 to 29 days after the satellite has scanned the area of interest. After allowing a few days for image analysis, the information is from three weeks to one month old, which in many agricultural situations is unacceptable. Data delivery is expected to improve with the implementation of a new processing system at NASA's Goddard Space Flight Center (GSFC) and the EROS Data Center. These systems are being designed to provide the data within seven days.

In 1976, the USDA LACIE Project Office funded a study by the METREK Div. of MITRE Corp. similar to that discussed in the article by Mr. Teicholz. The study followed slightly different criteria in its analysis of existing digital image processing systems. The study ultimately led to our procurement of a system that uses a PDP-11/70 with a Floating Point System AP-120B array processor and an International Imaging Systems (I²S) display system. The system operates under the DEC IAS operating system and the Integrated Multivariate Data Analysis and Classification System (IMDACS) developed by Ford Aerospace and Communications Corp. This system is currently undergoing tests in a LACIE facility located near the NASA/Johnson Space Center.

DAVID DURICA, Leader
Technical Support Group
LACIE Project Office
U.S. Dept. of Agriculture
Washington, D.C.



PDP-11, NOVA, Level 6, MDS 800/888, ZDS/MCZ Z80, EXORcisor, COSMAC

and other users... attend our free software seminars and find ideas they can put to work. Ideas about a new approach to programming — FORTH — a fully interactive stand alone disk base OS, a multi-level language with combined assembler, compiler and interpreters; an extensible dictionary using indirect threaded code; and much more. Results? Program development time cut 50 to 90%, memory requirements slashed 30 to 80%, run time optimized and applications that are transportable. We know this sounds farfetched. Let us prove it.

OK, sign me up for FORTH's free software seminar in:

- | | |
|--|---|
| <input type="checkbox"/> Los Angeles, Sept. 13 | <input type="checkbox"/> Chicago, Sept. 19 |
| <input type="checkbox"/> Cleveland, Sept. 21 | <input type="checkbox"/> Washington, D.C., Sept. 22 |
| <input type="checkbox"/> Anaheim, Oct. 5 | <input type="checkbox"/> Oakland, Oct. 18 |
| <input type="checkbox"/> Palo Alto, Oct. 19 | <input type="checkbox"/> Orlando, Oct. 27 |
| <input type="checkbox"/> San Fernando Valley, Nov. 9 | <input type="checkbox"/> Boston, Nov. 15 |
| <input type="checkbox"/> New York City, Nov. 16 | <input type="checkbox"/> Philadelphia, Nov. 17 |
| <input type="checkbox"/> Other | |

Send me more information on miniFORTH microFORTH
 Application Programming Services

Name/Title _____

Firm _____ Phone (____) _____

Address _____

City/State/Zip _____

Forth, Inc., 815 Manhattan Ave., Manhattan Beach, CA 90266, (213) 372-8493

FORTH, Inc.

D978

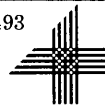

Hewlett-Packard Computer

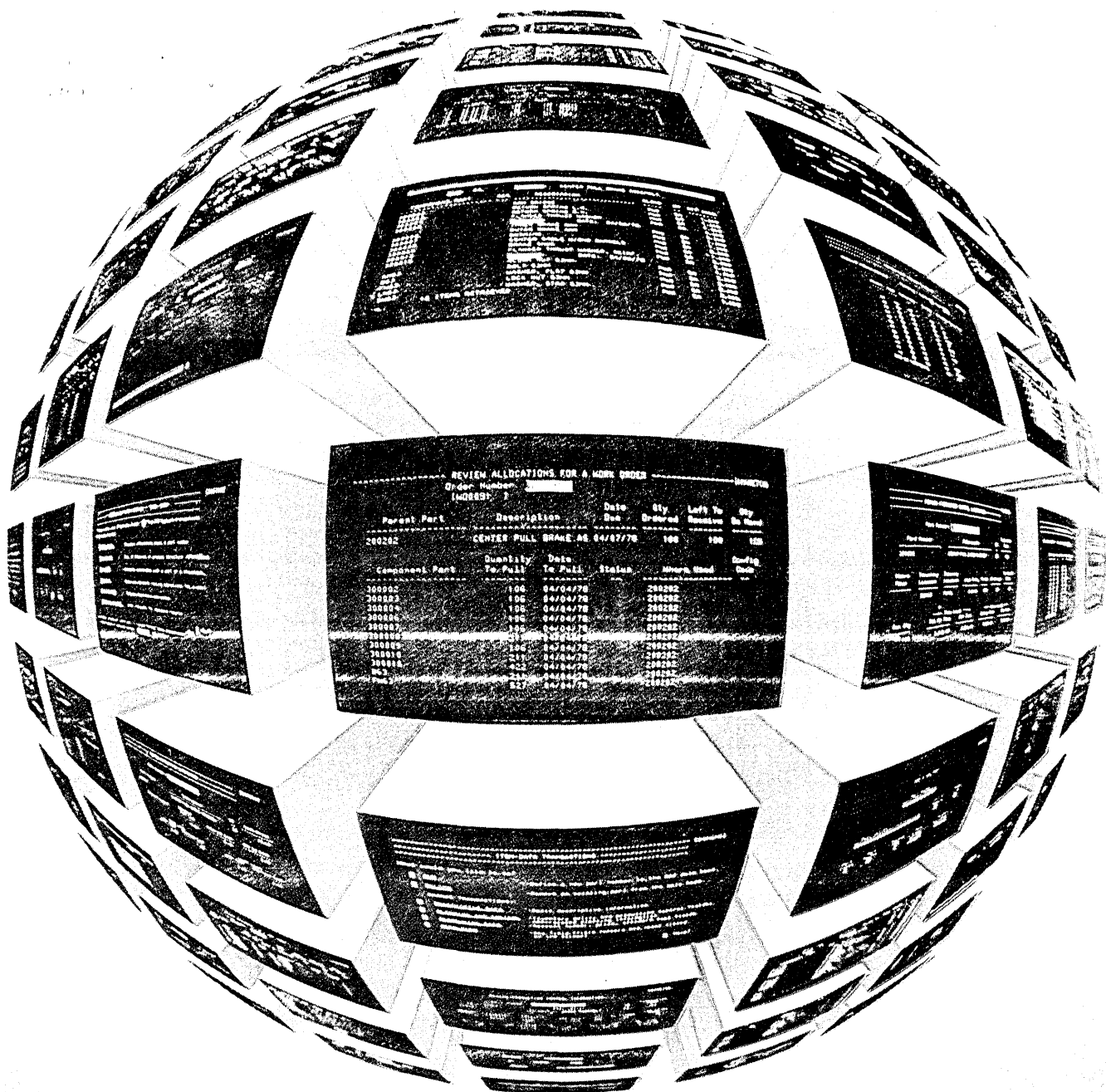

At the heart of HP's systems are products like world's first mainframe multiprocessing

and data base management system (DBMS) from premier—line (HP 2150)

The HP 3000 Series III: more transactions, more data, more memory, more software...

Companies are placing computers out where the action is—into the hands of the people who are closest to and most familiar with the company's data—for example, employees in order processing, shipping, accounting, and manufacturing. These people enter the data to update the data base or initiate other processing and within

seconds receive a confirmation or response which completes the transaction. Instantly, that same current data can be available to authorized persons throughout the company, even those at remote locations. This is on-line transaction processing and represents what the majority of 1500 HP3000 systems installed in business and

industry are doing. Now, with the introduction of the more powerful HP3000 Series III, our systems perform even better in this demanding environment.

Fast response time

People engrossed in their work don't want to wait for a computer response. Yet when many people are all competing for the same system resources, as in a transaction processing environment, response time and throughput may suffer. To avoid this problem, the new

There are immediate answers for everyone with the new HP3000 Series III on-line transaction processing system. When multiple users share common programs and data bases—essential company business decisions can be made on the spot. Despite continuous change, valuable data is always kept current.

ONE SECOND IN THE WORLD OF TRANSACTION PROCESSING

Order Entry

An order entry clerk enters the customer's name. Address and credit status are displayed. Upon entry of the order (part numbers and quantities), availability, ship date, and price are displayed instantly, enabling prompt and accurate filling of customer orders.

Cost Accounting Update

A cost accountant accesses and shares purchasing and manufacturing data to keep standard costs up-to-date. These costs, revised in a matter of seconds, allow tight control over product prices and manufacturing expenses.

Inventory Retrieval

A manufacturing supervisor needs inventory status of several parts. Part numbers are typed in and on-hand quantity, outstanding orders, and date due in-house are displayed immediately. She can schedule production line work effectively, based on present inventory and future part orders.

Shipping Retrieval

A shipping clerk filling orders enters a customer order number on his terminal. An address label and packing list noting those items included in the shipment and those backordered are immediately printed—enabling quick, accurate order shipment.



HP3000 Series III was specifically designed for high performance in a transaction processing environment.

For example, the operating system, MPE III dynamically allocates system resources such as memory, processing time and peripheral devices to ensure low response time and high throughput in an on-line transaction processing environment. With advances such as multi-use interactive processing, and multiple languages (BASIC, COBOL, FORTRAN, RPG, and SPL), MPE facilitates transaction

processing without a special monitor.

Increased memory

By increasing our internal memory capacity to 2 megabytes, we have minimized time consuming disc swaps, and greatly improved performance.

Board density, four times that of our earlier version, was achieved by packing new 16K RAM semiconductor memory onto 256K boards—each with error correction. At \$32,000 a megabyte, the

Series III memory is 46% less expensive than its predecessor and leads the industry in memory pricing.

We further increased performance by optimizing the HP3000 for a large number of terminals sharing the same programs and data base.

First, we analyzed the workings of our memory allocation manager and learned how to increase its efficiency.

Then, IMAGE, the data base management system of the HP3000, was enhanced to be more
Continued on page 4

Inventory Update

A materials receiving clerk processes incoming orders. The computer indicates what was ordered and those items received are entered into the data base. Order status and inventory are updated, giving up-to-the-minute accuracy.

Others

Sixteen other users are also accessing the system. Five order entry clerks are entering, updating, and cancelling orders. Order status is also being checked. Three buyers are viewing production schedules, determining part requirements, and purchasing parts. One materials receiving clerk is processing incoming orders, while one production control

supervisor is analyzing shipping targets. There are three accounting clerks working with accounts receivable, accounts payable, and payroll systems. And two programmers are developing and writing modifications: one to a financial forecasting program; the other to a new payroll program. A batch COBOL compile is also being printed.

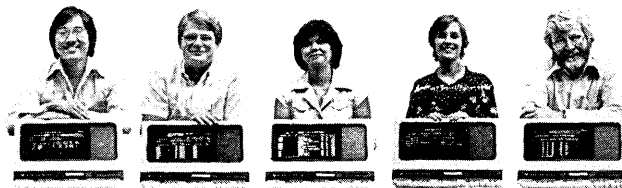

...less time, less money

HP3000 Series III, continued

transaction oriented. By changing to an internal buffering scheme, we can pool or share user data base control information. This reduces both disc access and memory overhead and results in a 30% increase in the number of users while response time remains the same.

Further, to guide our customers in selecting the exact configuration to handle their transaction load, we conducted a series of realistic application tests. We varied the environments and measured the performance of the Series III. The data we collected is available upon request. See the reply card.

VIEW/3000 software

VIEW/3000 plays two major roles. First, it is a stand-alone source data entry package. Data entry applications can be designed with no programming effort. Within minutes, users can begin entering data on-line. Second, as a front-end

to transaction processing application programs, VIEW/3000 augments programmer productivity.

VIEW/3000 provides the first step in the data entry process, forms design, without any programming effort at all. A form can be "painted" or drawn on the screen, and standard edit specifications chosen from a menu. VIEW/3000 also provides source data entry and validation for application designers again without writing a program.

More sophisticated data entry needs can also be satisfied with VIEW/3000. The VIEW design language provides complete field and form processing; advanced data editing, data movement, data formatting, and conditionals (if... then... else). In addition, full arithmetic capability is provided.

Finally, VIEW/3000 provides an extensive set of high-level terminal and data handling routines ("GETNEXTFORM" for example) callable from BASIC, COBOL,

MAIN MEMORY: \$32,000 PER MB

FORTRAN, RPG, and SPL. These provide a simple interface between a transaction processing application program, the forms created by VIEW and an HP2640 family terminal.

Easy user interface

Imagine a data entry clerk able to log on to the system and immediately begin entering data. The system designer assigns a name to a sequence of MPE commands that accomplish a given task. Whenever that name is referenced, the

ONE SECOND IN THE LIFE OF AN HP3000 SERIES III

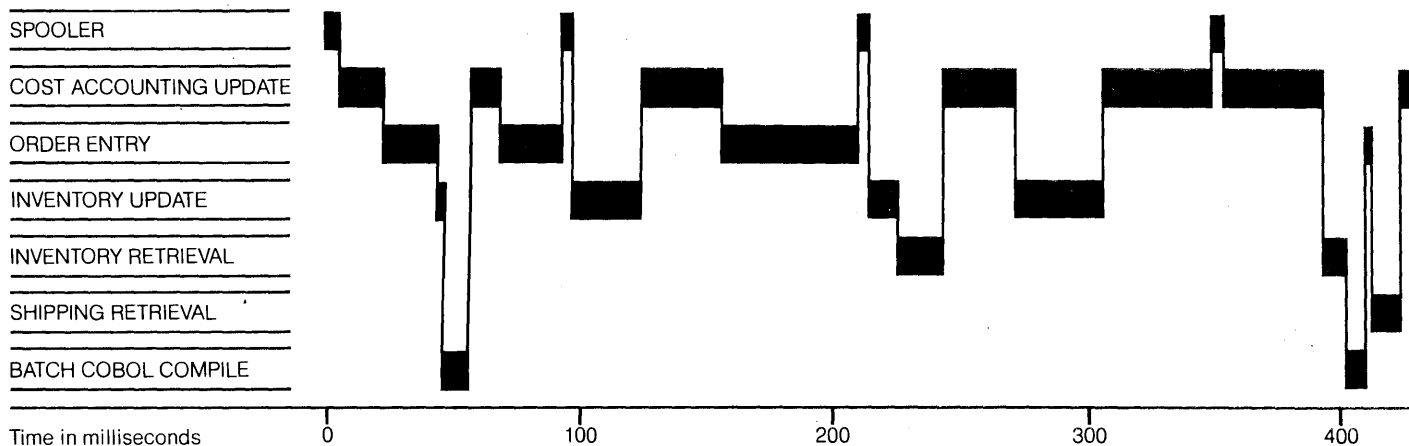

sequence is automatically executed.

To further conceal system commands from the user, the HELP facility which normally provides an on-line description of MPE commands, can be tailored to fit your application. You can display customized command descriptions. Similarly, you can tailor the system error messages to have more pertinent meaning to your users.

Large data bases

In a typical transaction processing application, data bases tend to be large. HP has significantly increased its on-line storage with the introduction of the HP7925. The Series III now supports up to eight HP7925 disc drives for a total capacity of 960 megabytes.

In a highly changeable environment, a fast and accurate method for system backup and recovery must assure data integrity. With HP's serial disc interface that backup is to a disc pack. Plus private

volume disc packs can be copied directly in a matter of minutes.

Never re-enter data

All data transactions that change the character of the data base are automatically logged by IMAGE. This includes a recovery program which restores transactions to the data base and eliminates the need to re-enter data in the event of a system failure. In addition, for MPE and KSAM files, you can set up your own logging records and establish an audit trail.

Sometimes it is essential for one user to have exclusive control of certain parts of the data base. IMAGE's associative locking provides a three-tiered, high-speed

locking scheme to accomplish this. Locking can occur for the entire data base, for one or more sets, or for one or more entries in a named data set—or for any combination of the three. Data is locked, not by record number, but by specifying the data contents. For example, "LOCK FLIGHT FILE WHERE FLNO = 92 AND LOCK PASSENGER FILE WHERE NAME = JONES" locks only those portions of the files, leaving the rest fully accessible to other users.

The HP3000 Series III base price is \$115,000*.

For more information, or for the Performance Guide, indicate A to C on the reply card.

*U. S. domestic prices only.

To illustrate what efficient system resource switching is needed to satisfy the demands of transaction processing, we tracked the Series III operating system, MPE, for just one second. Twenty users were doing simultaneous batch processing, on-line program development, and interactive data entry and inquiry to a data base. MPE III determined that six users needed CPU attention. Performance was high—2638 transactions occurred each hour, and response time averaged three seconds.

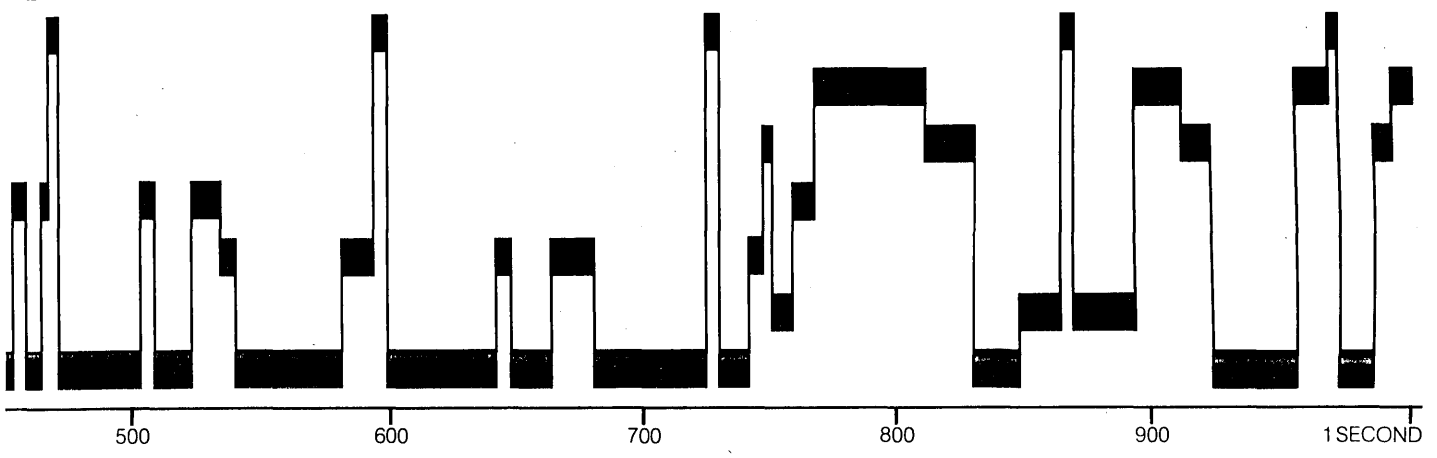

The HP 250: Easy to work at



The new HP250 computer system offers a rare and useful combination of product design and software. Human engineered to reflect the way people like to work, and with software tools to facilitate user interaction and increase programmer productivity, the HP250 is a computer system for small companies or departments of larger companies.

A major breakthrough of the HP250 is the combination of true data base management and extensive software tools for report and forms generation—all for under \$25,000*.

The HP250 hardware is a state-of-the-art 16 bit N Channel MOS microprocessor which handles computation with 12 digit accuracy. Up to three flexible disc drives of 1.2 formatted megabytes each pro-

vide expanded storage. The entire operating system is loaded from flexible disc into its own internal memory space. Thus, it is always on-line, ready for instant use.

Ergonomic design

Well before the design drawings of the HP250 were done, we took the time to observe people entering customer orders at a terminal.

Nobody did the job the same way. Some individuals moved the customer reference books from left to right, as well as the source document and, interestingly enough, even the CRT display screen. Everyone had their own approach to positioning the elements, and their own preferred position for entering data at the keyboard.

To accommodate this wide range of preferences, several design conclusions

were reached. First, the desk area must provide users with ample space in which to arrange their paperwork. Second, all key elements should be within arm's reach. And third, the CRT must move.

Slide, swivel, and tilt

Perhaps the most singular expression of the HP250's commitment to human engineering is in its innovative, adjustable display screen. It slides from side to side, swivels about a vertical axis, and tilts. This range of adjustment accommodates all preferences for positioning the screen.

The movements are wide, but assist comfort in subtle ways. For example, people wearing bi-focals can tilt the screen ever so slightly to facilitate their viewing. Where lighting variations

necessitate slight angling to reduce distracting glare, the HP250 adjusts. Key in the development

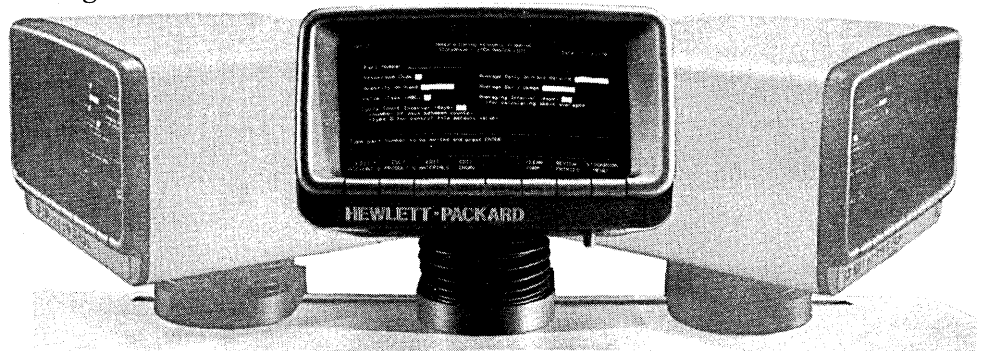
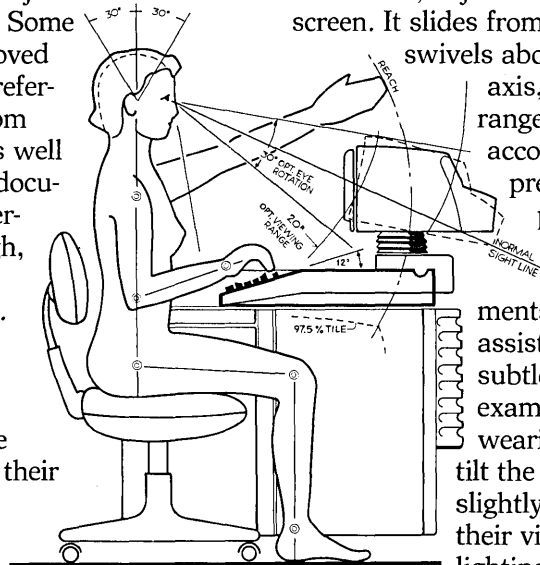

of the HP250 was the desire to simplify its design and use to accommodate an operator's unfamiliarity with computers. It was essential, we believed, not to intimidate users with a complex array of confusing, symbolic keys. So the keyboard looks and acts like a typewriter.

The keyboard's height, slope, and innovative contour optimally encourage "homing" in on keys. The keyboard

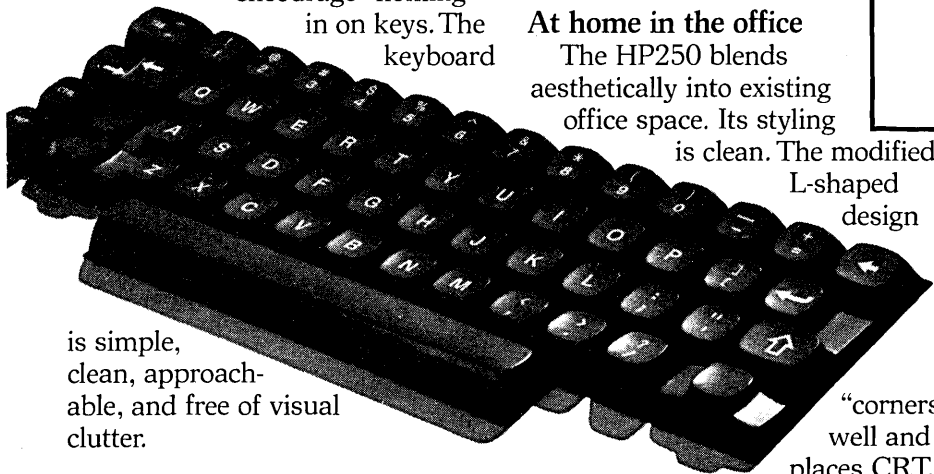

is simple, clean, approachable, and free of visual clutter.

Softkeys

Eight "softkeys," or special user defined function keys, are located along the bottom edge of the display screen and provide an innovative means for easy operation. A displayed message above each softkey describes its present function. Pressing this key begins an operation. Upon completion, the program branches automatically to the next step in the routine and new softkey definitions appear. This approach steps relatively untrained operators effortlessly through several layers of complicated procedures and reduces the possibility of their inputting errors.

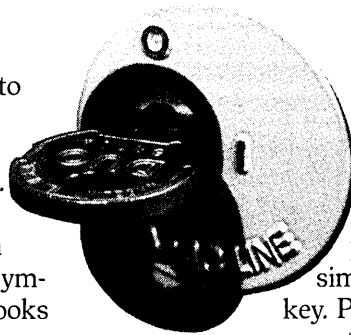

Easy on, easy off

The on-off switch reduces power-on procedures to a simple turn of a key. Plus, at turn-on, an automatic self-test assures you that everything is working.

At home in the office

The HP250 blends aesthetically into existing office space. Its styling is clean. The modified L-shaped design

"corners" well and places CRT keyboard, and disc within easy

reach. Accent panels, available in several colors, help coordinate the HP250 to the office decor. A concern for noise reduction led to an efficient multiple-fan approach for cooling. All the heat producing elements were separated into three different heat compartments, each with its own low-volume and quiet fan.

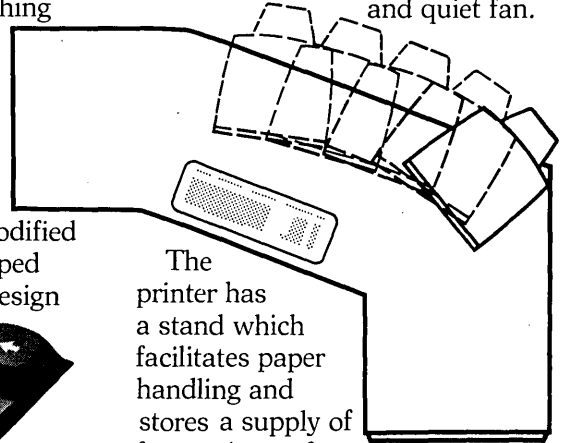

The printer has a stand which facilitates paper handling and stores a supply of forms. A set of quick reference cards in the console drawer capsulizes key instructions. Also, the HP250 can easily be rolled wheelbarrow fashion.

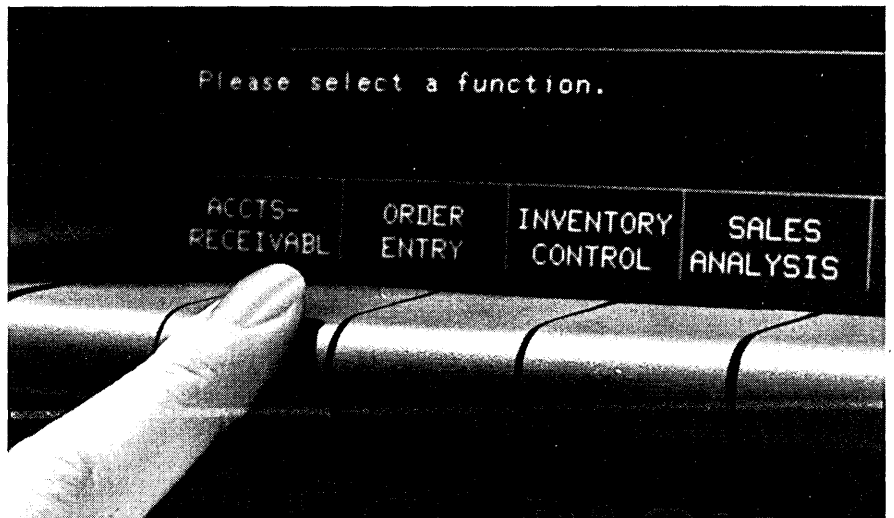

The HP 250: Easy to work on

Service with dignity

Our service engineers can repair your HP250 wearing their suits. A menu driven, hierarchical, self-test speedily isolates problems to a board level. The entire card cage rolls out from the front. Repair

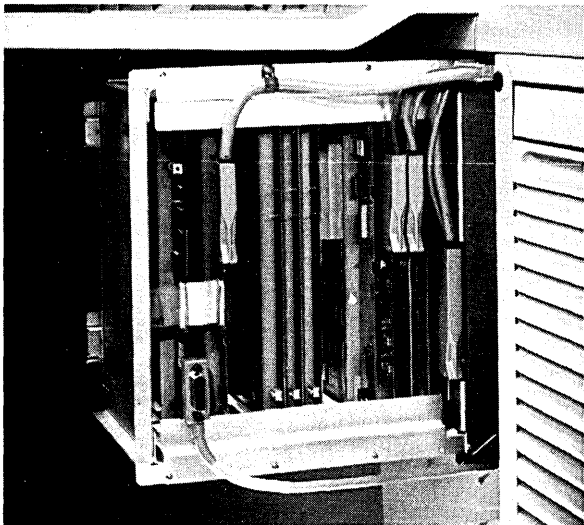

is then as simple and clean as a board exchange. The self-test is a diagnostic tool, not a go/no-go approach. In fact, a 16 position indicator helps service engineers track intermittent problems.

Business BASIC

The HP250 represents a high standard of human engineering. This, in combination with high-level software results in a powerful, yet simple to use programming system.

The HP250's programming language is an enhanced business version of HP BASIC. It has sub-programs, string manipulations, and multi-dimensional (6) arrays (numeric and string). It includes commands for mass memory control, print formatting, softkey

control and CRT formatting.

The capability to name variables using up to 15 characters makes programs more readable. The true subprogram capability provides local variables to the subprogram with parameter passing. This is a

powerful tool for writing general routines that can be used by any program.

Data base capability

Modeled after the award winning IMAGE/3000, IMAGE/250 is a collection of utilities and commands that create, control and maintain a complex information management system with full security. Sorting and finding across data sets is one of its powerful capabilities.

IMAGE/250 has multi-volume data base capability. The user is not restricted to the on-line flexible disc capability. The data base can be organized into logical sub-sets. These different files, each on separate discs and rapidly loaded when needed, integrate to form a full data base. The operating system attends to over-head and provides checks such as locking the drive when a disc is being accessed. Plus, the HP7906 disc with 20 megabytes of storage is available to further accommodate growth.

QUERY/250 facilitates free form, authorized, unprogrammed access to this stored information. Its frequent prompts assist inexperienced users in retrieving, up-

dating or modifying data. No additional programs need to be written.

User forms on screen

With the programmer's tool FORMS/250, the paper forms that employees are familiar with can be easily recreated to appear on the CRT screen. A straight-forward, branching menu approach prompts you through the forms design process.

A full line drawing set enables careful matching to the paper form. Since the forms are treated as independent files, they can be modified or tailored later without affecting the BASIC program. Once a form is created, the user can display it on the screen, fill-in the blanks, and press a key to log the entire transaction. This technique speeds data entry and requires minimal operator training. Softkeys can also be assigned to execute a series of up to 160 key strokes. This typing aid short cut relieves programmers from re-entering frequently used phrases or sequences.

Create a report

Report WRITER/250 gives the application programmer a versatile set of commands to generate final, professional looking reports which can include totals, averages, formatting and summaries. This package greatly reduces the time and cost usually involved in developing an original report format or making changes to an existing one.

Large computer features

With the HP250, thoughtful attention and care was given to the



design of a tasteful office computer. Yet, priority remained with providing system development tools to aid a programmer to custom design application packages in the lifestream areas of a company, for example finance, and manufacturing inventory.

The HP250 computer system costs \$24,500*.

We would be pleased to share more HP250 information with you. Indicate D on reply card.

*U.S. domestic prices only.

The new HP250 computer system design reflects simplicity and end user appeal. Within arm's reach are keyboard, CRT display screen, flexible

*disc storage, and a quiet printer. With features like IMAGE/250, a true data base management system, and software tools to generate forms and reports, the price is surprising — less than \$25,000**

Got the picture? We've got the numbers.

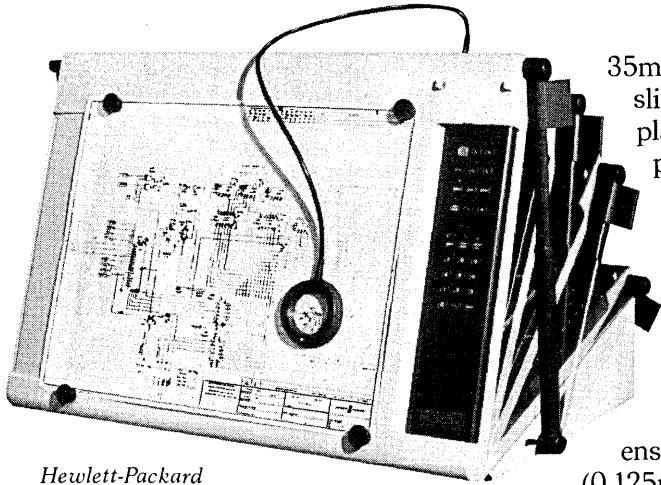

Hewlett-Packard makes digitizing more accurate and comfortable for the user with the HP9874—a completely integrated workstation digitizer with many innovative features including a tiltable, transparent glass platen.

A new digitizer from Hewlett-Packard, the HP9874, expands the range of materials which can be digitized. Valuable data is often trapped in pictorial form—lengthy strip charts, large blueprints, and X-rays. Now there is a better way to digitize or convert this graphic data into numeric form for computer analysis and processing.

Tilt to any angle

Traditionally, digitizers have had a non-movable horizontal work area, or platen. Users had to stand and bend for many hours over a document being digitized. The HP9874 relieves this tedium—it has an innovative, adjustable, transparent glass platen. Easily tilted to any angle, you can work in a relaxed sitting position.

Digitize an X-ray

An adjustable glass platen enables the digitizing of projectable media such as X-rays, movie frames,

35mm or microscopic slides. By tilting the platen to a full vertical position and setting a projector behind the digitizer, exact images can be reproduced without distortion, then digitized.

Use of a stable material like glass for the platen ensures high accuracy (0.125mm) and resolution (0.025mm) over a broad range of temperature and humidity conditions.

To take advantage of the adjustable platen, HP developed a “vacuum-grasp cursor” which can adhere to any portion of the platen. Regardless of the platen’s position, the cursor will not slip—even if it is bumped.

The lighted cursor has an open circle target, 0.250mm in diameter, giving the pinpoint precision necessary to accurately position and then move the cursor along a line thinner than a human hair. Digitizing becomes as simple as tracing.

Smart integrated peripheral

The HP9874 is a powerful, intelligent digitizing workstation complete with its own microprocessor and 16K-bytes of built-in memory. Because of this power, the HP9874 can respond to forty high-level programming commands.

Full control of any digitizing application is at your fingertips. A keyboard, conveniently located on the digitizer, has control, numeric,

and special function keys.

Points may be digitized one at a time or continuously (based on time or distance increments) by simply pressing the appropriate key. An Axis Align key automatically aligns the x and y axes of the digitizer with those of the document—immediately establishing a new coordinate system. And, by pressing the Axis Extend key, strip charts, as long as 53 kilometers, and other large documents can be digitized with all points referenced to the initial origin.

The numeric key pad can annotate each digitized point with a numeric identifier. This feature is extremely valuable in setting up a third dimension (or z axis).

There are also five special function keys which act as triggers to initiate branching routines within a computer program. These keys, combined with the shift key, give you a total of ten.

The HP9874 is compatible with the Hewlett-Packard Interface Bus (HP-IB)** and sells for \$6,200*
Check E for more details.

*U.S. prices only.

**IEEE Standard 488-1975 Interface.

Computer Advances is written to inform professionals of the latest technical contributions from Hewlett-Packard. You are invited to receive issues at your place of business or residence. Write Carol Scheifele, Computer Advances, Editor, Hewlett-Packard, 11000 Wolfe Road, Cupertino CA 95014.

HEWLETT  PACKARD

ADDS SYSTEM 70. OEM.

7 good reasons why System 70 is easy to buy and even easier to sell

1 Buy a lot. Save a lot. Big OEM discounts mean money in the bank.

2 ADDS* PLUS Data Entry Language, Advanced Diskette Operating System (ADOS), BASIC, FORTRAN IV, Assembler, editing and debugging software are all field proven. And, this extensive software simplifies implementation and saves you dollars.

3 We build 'em for you fast. Our 45 day delivery schedule means less inventory and more money in your pocket.

4 Our Nationwide service means you've got it easy. Over 50 service locations make sure that System 70s keep on working. We provide the service. You save the dollars.

5 With more than 65,000 terminals already installed, ADDS reputation for quality and reliability is unsurpassed.

6 Our terminals fit your customers. System 70's beautiful exterior is human engineered for maximum operator convenience and ease of operation.

7 IBM 3780, Burroughs and teletypewriter communications are all available, making System 70 the right choice for almost any distributed processing environment.

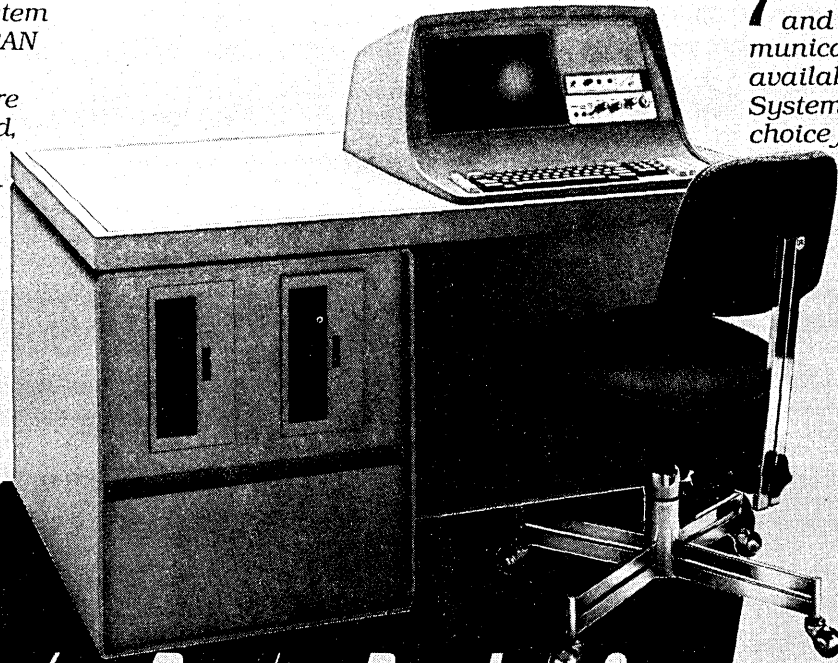

Quality, Reliability, Integrity. It all adds up to ADDS.

ADDS Applied Digital Data Systems Inc.
100 Marcus Blvd., Hauppauge
New York 11787 516-231-5400
DEPT. 70.

I need more information on the System 70. OEM.

Name _____

Firm _____

Title _____

Address _____

City _____

State _____

Phone _____

CIRCLE 18 ON READER CARD

No one else looks this good under glass.

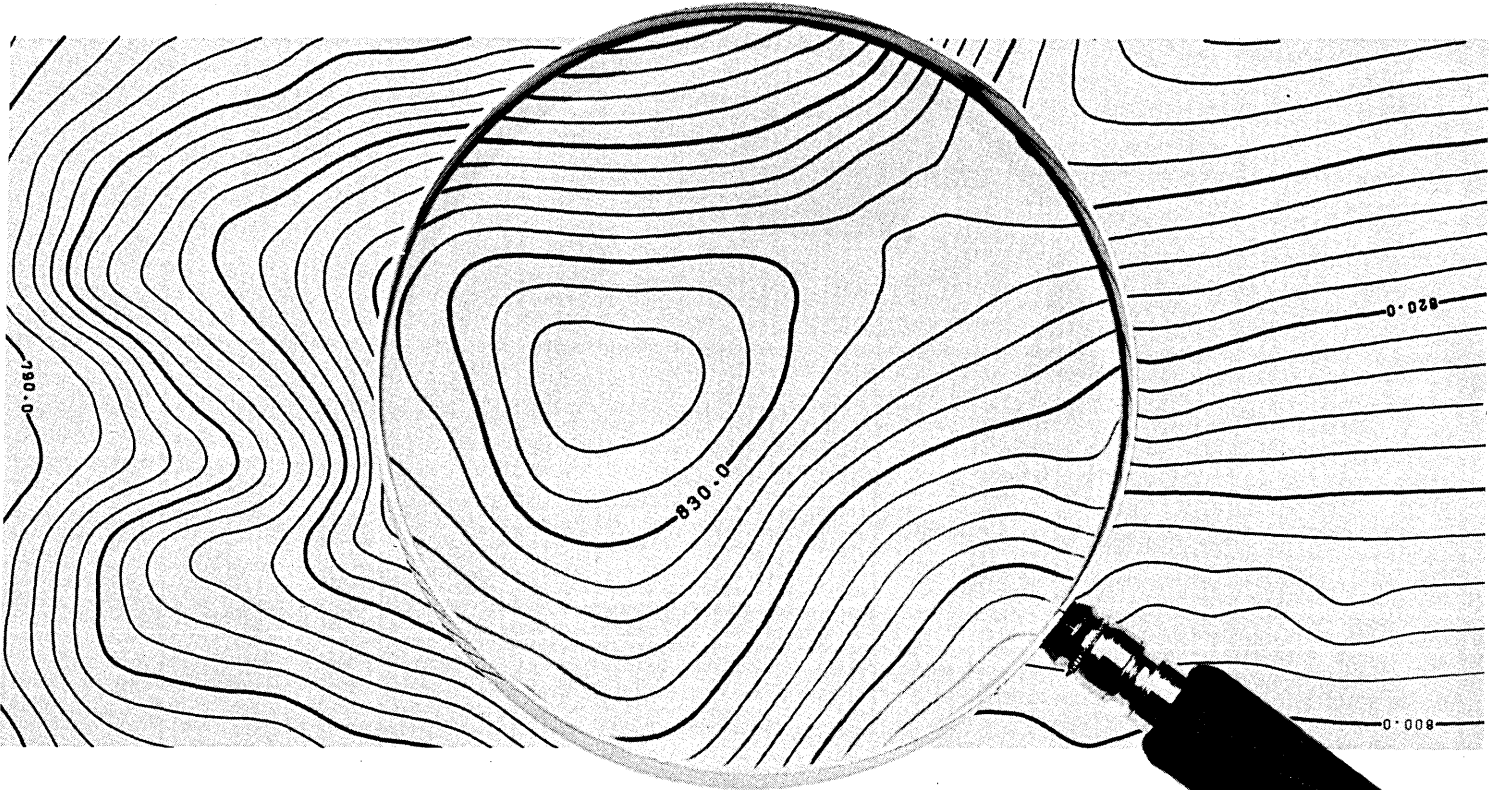

If you're shopping for a medium-priced drum plotter, the old eye-ball test is still a good place to begin. And so's CalComp.

Because no matter how you scrutinize our graphics – or measure our output – one thing comes clearly into focus: CalComp makes the best drum plotters in the world. Period.

Case in point: Our new 1030-Family of medium-priced drum plotters. In terms of accuracy, line quality, speed and good old-fashioned price/performance, they literally outdraw the competition. At every turn.

Better yet, all three new plotters are perfectly suited to a wide range of graphics applications. And that means, with the help of a new 1037, 1038 or 1039 plotter, any data now in your computer can work even harder for you outputted in an easier-to-understand graphic form.

A clear case of superior engineering.

For starters, we made all three new models completely d.c. servo-motor driven. For increased accuracy in every mode. On-line. Remote/time-sharing. And off-line.

Then, we gave them all a newly-designed linear drive pen mechanism. For the kind of pen force control that produces consistently superior line quality. In every application.

Next, we greatly increased overall throughput – especially in on-line environments – by implementing "smarter," microprocessor-based controllers.

Finally, there's even greater built-in versatility. Because both the 1037 and 1038 can be field-upgraded – all the way up to a new 1039 – without ever leaving your office.

Service and Support that's a sight for sore eyes. The one thing we haven't changed is CalComp service and support. It's still worldwide and second to none. For field service personnel. For in-place field systems analysts. For the kind of help you expect from the world leader in digital graphics.

All of which proves, when it comes to drum plotters, it pays to set your performance sights a little higher.

THE NEW 1030 DRUM PLOTTER FAMILY

plotter model	mm-per-second	pens	step size in mm
1037	50.0 (≈ 2.0 in.)	1	.05 (≈ .002 in.)
1038	112.5 (≈ 4.5 in.)	1	.05 (≈ .002 in.)
1039	112.5 (≈ 4.5 in.)	3	.05 (≈ .002 in.)

Draw your own conclusions. It's easy with a free CalComp sample plot. For your own evaluation copy, call: (714) 821-2011. Or write: CalComp, 2411 La Palma Avenue, Dept. MS-3, Anaheim, California 92801.

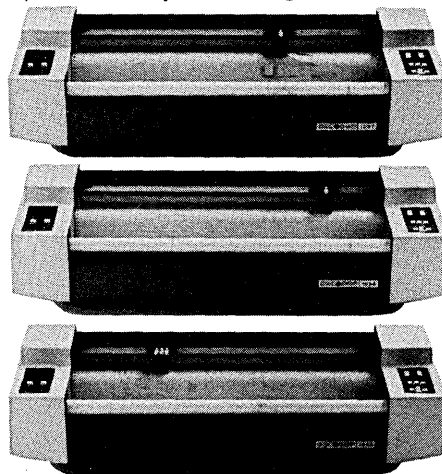

CALCOMP
CALIFORNIA COMPUTER PRODUCTS, INC.

WEST: Orange, CA (714) 639-3690 / Santa Clara, CA (408) 249-0936 / Houston, TX (713) 776-3276 / Dallas, TX (214) 661-2326 / Englewood, CO (303) 770-1950 / Beaverton, OR (503) 646-1186.
SOUTH: Norcross, GA (404) 449-4610 / Huntsville, AL (205) 533-6260. **MIDWEST:** Southfield, MI (313) 569-3123 / Rolling Meadows, IL (312) 392-1310 / Dayton, OH (513) 276-3915 / Cleveland, OH (216) 362-7280 / Shawnee Mission, KS (913) 362-0707 / Bloomington, MN (612) 854-3448. **EAST:** Waltham, MA (617) 890-4850 / Union, NJ (201) 686-7100 / Bala Cynwyd, PA (215) 667-1740 / Rockville, MD (301) 770-5274 / Pittsburgh, PA (412) 922-3430.

CIRCLE 14 ON READER CARD

A 32K byte dual floppy microcomputer system for only \$2900* complete.

Standard Features:

- Dual 8" floppys store 500,000 characters on line
- 32K bytes of static RAM
- RS-232 C at 75 to 19,200 baud
- 16 line parallel I/O
- Rack or tabletop mounting
- UL-recognized power supplies
- BUS oriented computer architecture
- Four slots used — four slots open for expansion
- Comes complete with disk BASIC
- Includes Interactive Assembler/Editor
- Main processor is an ultra-fast 6502A
- Has auxiliary Z-80 and 6800 micros which allow execution of virtually all 6502, 6800, 8080 and Z-80 code!
- User programmable interrupt vectors on all three micros

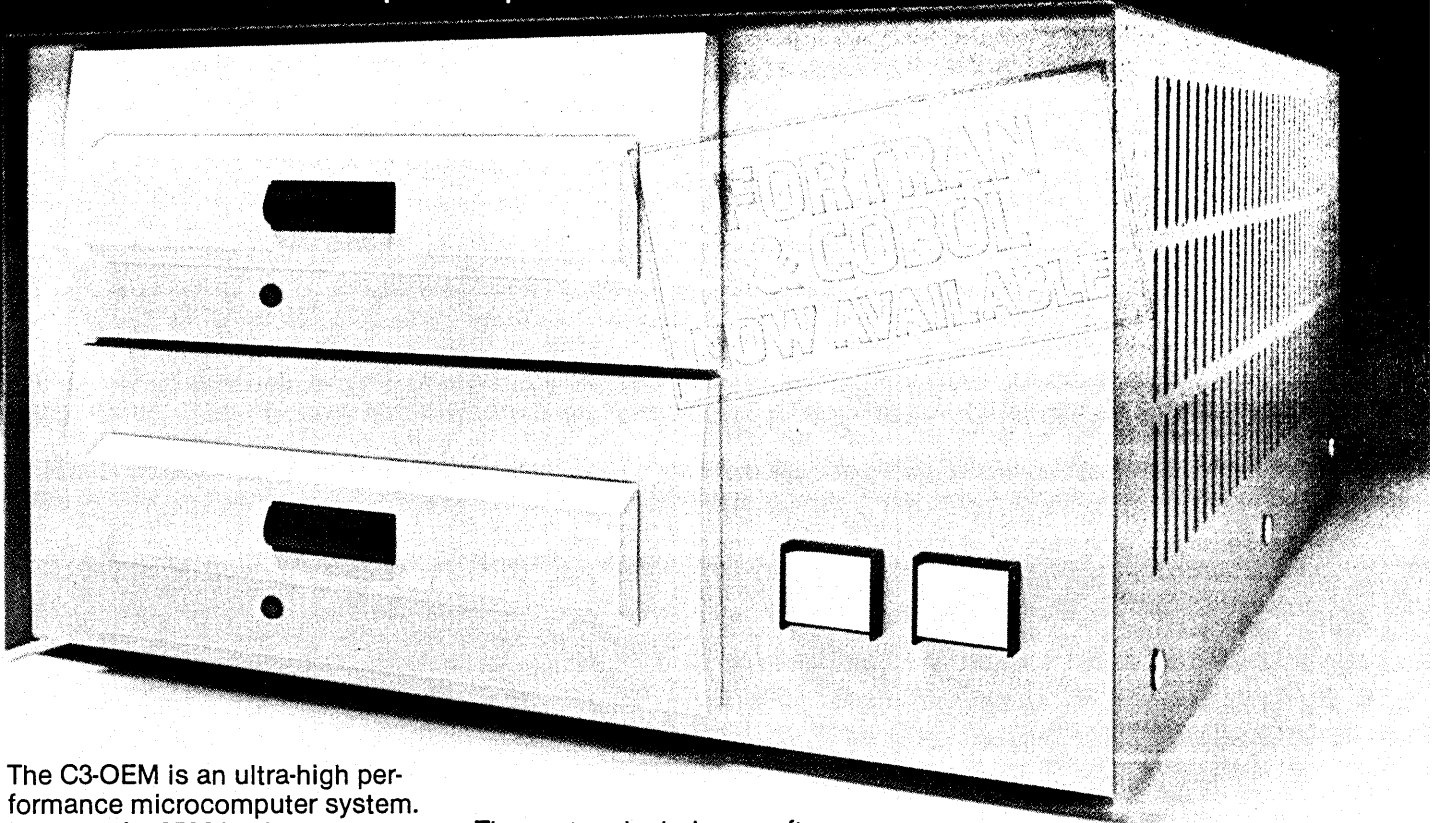

The C3-OEM is an ultra-high performance microcomputer system. Its powerful 6502A microprocessor (now triple sourced) out-benchmarks all 6800- and 8080-based computers in BASIC and machine code using the BASIC and assembler provided standard with this system.

In fact, the C3-OEM executes standard BASIC language programs at speed comparable to small 16 bit minicomputers.

Ohio Scientific has a vast library of low cost software for the high performance 6502A including an on-line debugger, a disassembler, several specialized disk operating systems and applications programs such as our word processor package and a data base management system. However, the C3-OEM is not just limited to 6502 based software. This remarkable machine also has a 6800 and a Z-80 microprocessor.

The system includes a software switch so that machine operation can be switched from one processor to another under software control!

So, one can start with existing 6800, 8080 or Z-80 programs while developing new software for the ultra-high performance 6502A.

The C3-OEM isn't cheap. It's a quality product with mechanical features like UL-recognized power supplies, a three-stage baked-on enamel finish and totally modular construction.

It is the product of Ohio Scientific's thousands of microcomputer systems experience. In fact, all the electronics of the C3-OEM have been in production for nearly a year and have field proven reliability. And, best of all, this machine is available now in quantity for immediate delivery!

A full spectrum of add-ons are now available including more memory, up to 16 serial ports, 96 parallel I/O lines, a video display, a parallel line printer interface and a 74 million byte Winchester disk drive.

*25-49 unit price

1-4 \$3590.

5-9 \$3300.

10-24 \$3100.

Phone (216) 562-3101
or write for more information
and the C3-OEM representative
in your area.

OHIO SCIENTIFIC

1333 S. Chillicothe Rd.
Aurora, OH 44202

The only source you need for remote batch, interactive, and distributed processing systems...HARRIS.

The Total Source

When you're in the market for data processing products, it's important to remember one fact that is often overlooked: you're not just buying equipment, you're buying commitment.

That's why you should be looking at Harris as the only source you need, whether your requirements are for remote batch terminals, local or remote interactive terminals, data entry products or systems for distributed data processing.

Behind Harris products is an \$800 million per year company with a solid record of financial stability and growth. Data Communications is one of the largest Harris Divisions, with established products, seasoned field and support organizations, and a commitment to continuing leadership based on heavy investments in research and development.

You buy Harris products with confidence that we'll be around when you need us — not just today and tomorrow but years from now. And you can be assured that your product base will stay at the state-of-the-art with no danger of obsolescence.

Families of Products from a Single Vendor

The Harris solution to your data processing problem is built around a modular hardware and software structure that grows with you as your requirements change and increase. We offer families of products and make it easy for you to upgrade within families. You set your own pace and Harris supports you all the way. And, if your processing calls for several different kinds of terminals, Harris can meet your needs... and give you all the advantages a single vendor can provide!

Remote Batch Terminals



HARRIS 1620 remote batch terminals feature multiple communication with up to four hosts simultaneously, a wide variety of popular emulators, and transmission speeds up to 56,000 bits per second.

Harris offers three families of remote batch processing products for entry-level, medium function, and high-function applications: the Harris 500, 1200 and 1600 series respectively. As an example of the product-family concept, our economical Harris 1610 is built around a memory-based operating system, performs remote batch and media conversion and includes a wide variety of proven peripherals.

Step forward from the 1610 and you grow into our Harris 1620 with capabilities including multiple emulators (up to four concurrently), to most major mainframes. Either the 1610 or 1620 can be field-upgraded to our distributed data processing products.

Systems for Distributed Processing

You can choose from four Harris 1600 systems for distributed data processing. The Harris 1650 is the first 1600 model to incorporate a mainframe-type disk operating system. It provides data entry and remote batch processing concurrently. Next, our Harris 1660 adds programmability in either interactive or batch modes and accommodates both format-driven and program-driven interactive applications. Then we offer the Harris 1670, featuring the significant advantages detailed below, and the Harris 1680 which uses dual processors for expanded concurrency capabilities.

Interactive Terminals

For the growing interactive market, Harris offers the established 8000 series. The proven Harris 8170 emulates IBM 3270 models 1, 2, 11 and 12 and is SDLC compatible. Emulation is also provided for the IBM 3272 controller. Other Harris interactive products emulate Burroughs, Univac and Honeywell terminals. Our top-of-the-line 8180 includes dual diskettes with 500K bytes of off-line storage, five megabytes of disk storage (optional), and up to 96K bytes of memory. These enhancements permit applications such as local format storage, spooled print and queued transaction handling.

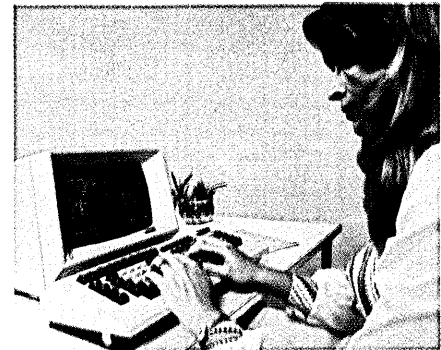

HARRIS 8000 series terminals communicate interactively with IBM, Honeywell, Univac and Burroughs mainframes.

Everything You Need for Distributed Processing... in One System

We've combined the capabilities of our 8170 interactive product with our 1660 distributed data processing product, both leaders in their respective fields, to provide a powerful new system for distributed data processing. We call it the Harris 1670. It's the *one system* you've been waiting for that will perform five basic data processing functions: local or remote batch, data entry, local interaction and remote interaction *concurrently*. Combining two major Harris resources enables us to produce the 1670 in volume, assuring you a competitive price and unbeatable performance. This single, modular system can fill

your terminal requirements — batch, 3270-compatible, and data entry — and is capable of growing with your processing needs in all these areas.

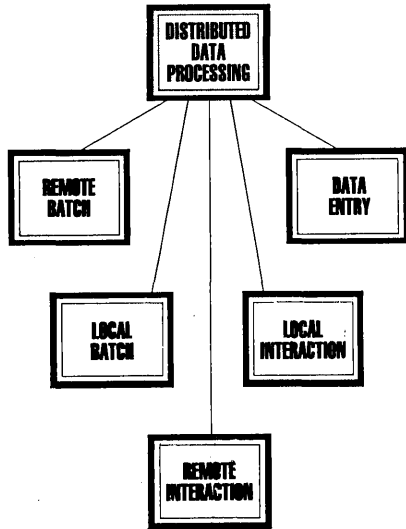

The five typical elements of a distributed data processing system.

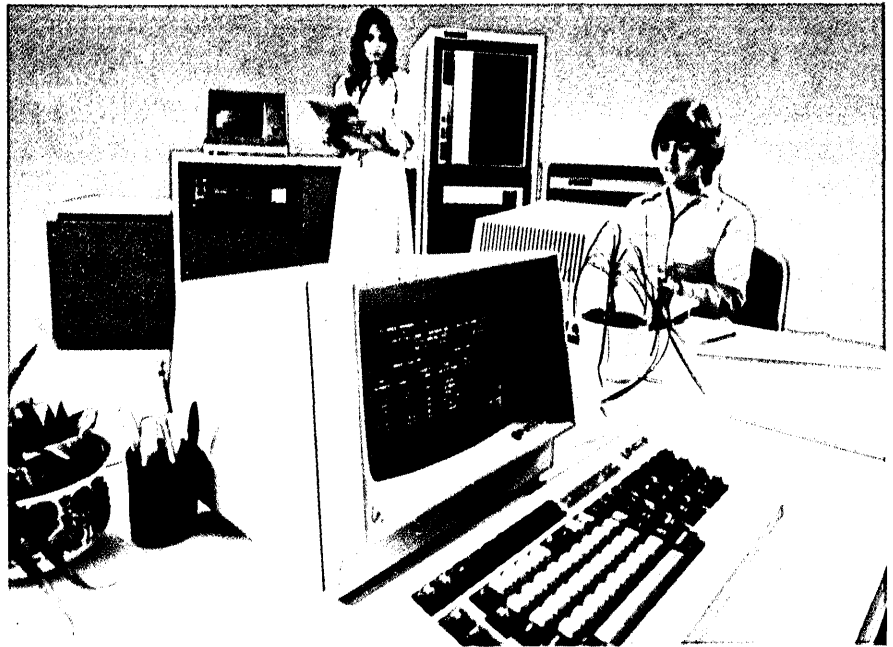

Sophisticated new HARRIS 1670 distributed processing system offers local or remote batch processing, data entry, and local and remote interaction concurrently. CRTs are individually switchable between local and host files.

Batch Processing

When devoted to remote batch communications, Harris' multi-task operating system enables the 1670 to perform any of the sophisticated RJE functions of the 1610 and 1620 models. In addition, the 1670 offers local batch processing with ANSI compatible COBOL and batch utilities, including SORT/MERGE.

Data Entry

You can choose from two format-driven data entry packages, easily implemented by data entry personnel. The two packages, Format 10 and Format 41, make your data entry jobs simple, efficient and effective.

User-Written Programs (Local Inquiry)

We offer an easily learned, English-like high level programming language (REGAL), for optimized screen management and for applications such as source document capture and interaction with the local 1670 data base.

CRTs running REGAL programs can be located either at the 1670 site or remotely. Additionally, the CRT can control station printers to produce required hard copy.

Remote Inquiry (3270-Compatible Interaction)

This capability enables the CRT operator to connect through the 1670 to 3270-compatible programs at a remote host site.

Selectable Mode CRTs can be used to perform operations in the 1670 mode (including data entry and user-written programs), or to switch to 3270-compatible host programs. Switching is controlled individually at each station by the operator, and the system automatically ensures data integrity when switching from one mode to the other. Selectable Mode enables you to off-load the host by performing processing locally for the majority of your requirements, saving host resources for those occasions when data is not stored locally. Compare this

feature when you're evaluating distributed systems!

No Changes Required at Your Host

The fact is, both RJE and 3270-compatible applications can be executed using the 1670 with no changes or new investment in host software. What's more, you continue to save since we can upgrade most Harris 1600 and 8170 systems to 1670s with minimal disruptions to your operations.

Do It All with Harris

To sum up, there's no need now to shop around for a variety of systems to handle your requirements for remote batch, local or remote interaction or distributed data processing. Start with Harris and you're assured a migration path from the system you need today all the way to one you'll require in the future.

For more information, contact:

- DOMESTIC**
- Harris Data Communications Division, Dallas, Texas, (214) 386-2000
- INTERNATIONAL SUBSIDIARIES**
- Harris Systems Limited, Toronto, Canada, (416) 441-2400
- Harris Data Communications, S.A., Paris, France, 1 (043) 8125
- Harris GmbH., Frankfurt a.M., West Germany, 0611-67 80 39
- Harris Systems, Ltd., Hitchin, England, 0462-53462
- Harris Systems, Ltd. (Support Centre), Slough, England, 0753-34666
- INTERNATIONAL DISTRIBUTORS**
- Minidata BV, Leiden, Holland, 071-1315467
- UCC (Datacom), Ltd., Dublin, Ireland, Dublin 801981
- Data Terminal Systems, Milan, Italy, 31-62-08
- BDV Computer Products A.G., Basel, Switzerland, 061-22-8007
- AWA, Ltd., North Ryde, Australia, 888-8111
- Kanematsu Electronics, Ltd., Tokyo, Japan, 03-543-7611
- Conisa, Caracas, Venezuela, 781-8888

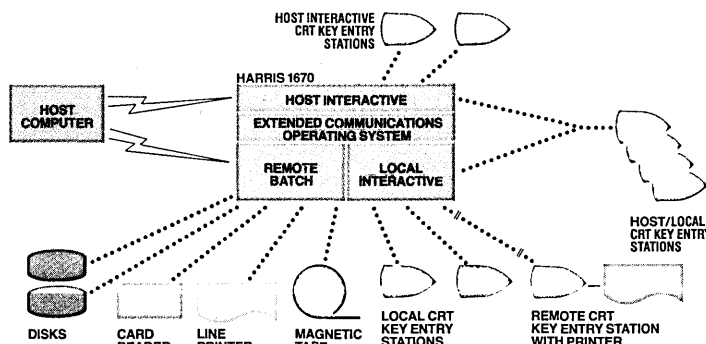

The new HARRIS 1670 combines the capabilities of the 1660 with concurrent interactive processing to a host mainframe ... and the HARRIS 1670 can be installed with no change in host software.

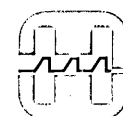

HARRIS
COMMUNICATIONS AND
INFORMATION HANDLING

Clean up your act

**Clean advantages of carbonless forms
now at costs you can afford—
Moore Clean Print®**

You will get cleaner, sharper computer printout copies on carbonless Clean Print. Moore's exclusive microencapsulation provides more color capsules per inch, so the images won't spread or feather. Surprisingly, Clean Print costs less than most other carbonless computer forms thanks to Moore's unique technology.

Moore Clean Print helps clean up your computer room, too. No carbon paper to soil hands and clothes. No carbon paper to decollate. No carbon paper disposal expense. (Save 10-30% on shipping weight by eliminating carbon paper and reduce storage space needed.) Because you get 10-30% more forms in a carton, you reduce forms loading costs the same percent.

In fact, when you add up all the savings, you'll probably find Clean Print forms cost less. Write for a Clean Print Sample Pack today.

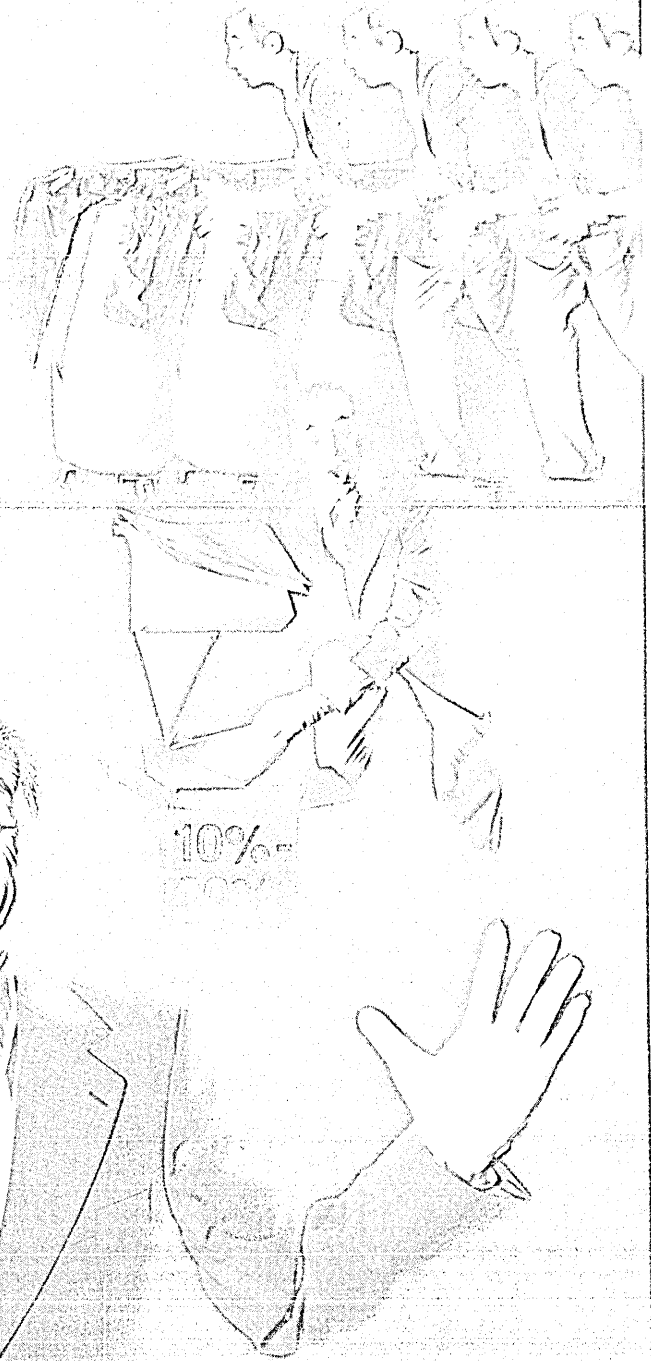

MOORE BUSINESS FORMS, INC. 1205 N. Milwaukee • Glenview, IL 60025 • 312/297-1600

CIRCLE 23 ON READER CARD

If you make top-quality data terminals, here are four reasons to use Setchell Carlson CRT display modules in your system.

Reliability:

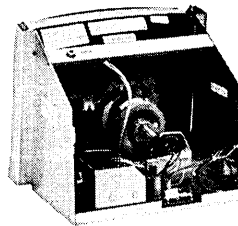

Our data displays are outstanding solid-state designs with critically matched magnetics to optimize the performance levels and dependability demanded by your customers. We use the most advanced engineering and production techniques to assure consistency of performance. No data display is built with more deliberate attention to quality and reliability.

Delivery:

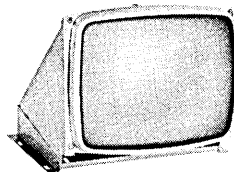

We have been in the display electronics business long enough to know about rush orders. If you need it yesterday — we'll try to get it to you yesterday.

Experience:

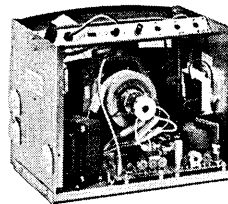

We've built thousands of displays for many of the major manufacturers in the country. Perhaps we already have a unit that would meet your requirements. With slight modifications. It would be less costly than starting from scratch. If you need a new, special package — we'll produce it for you, in the configuration you want, at minimal expense.

Cooperation:

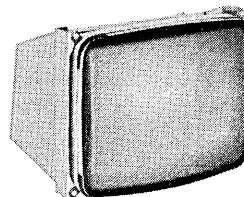

If you're developing a new data terminal, we will be glad to cooperate with your terminal design engineers in reviewing your exact specifications and developing the most economical display possible. And quickly! Whatever you need, we have the experience and talent to design it. And improve it.

But don't take our word. See for yourself by contacting us today.

You'll come up with your own reasons for using Setchell Carlson CRT display modules.

 **AUDIOTRONICS**
VIDEO DISPLAY DIVISION
530 FIFTH AVENUE N.W. NEW BRIGHTON, MN. 55112 • (612) 633-3131

COMPLETE AND MAIL THIS COUPON FOR THE FULL STORY ON DAY-FLO® PRE-INKED ROLLERS

Please send me brochures describing Day-Flo Pre-Inked Rollers; contact me, immediately, concerning my particular application.

Name _____

Firm _____

Address _____

City _____ State _____ Zip _____

Phone _____

Consider Dayco's complete line of microporous pre-inked rollers. Custom designed to fit your system or application.

Pre-inked rollers for credit card im-
printers, check encoders, character
printers, print-outs, ribbon re-inking,
high-speed character printers, on-

line marking and a number of other
printing and marking applications.

For the full story on the finest and most
complete line of pre-inked rollers
made, phone 513/226-5866. Or com-
plete and mail this coupon to: Dayco
Corporation, Marketing Services, 333
West First Street, Dayton, Ohio 45402.

DAYCO
CORPORATION



PRINTING PRODUCTS DIVISION

© 1978 Dayco

DISSPLA[®] Software

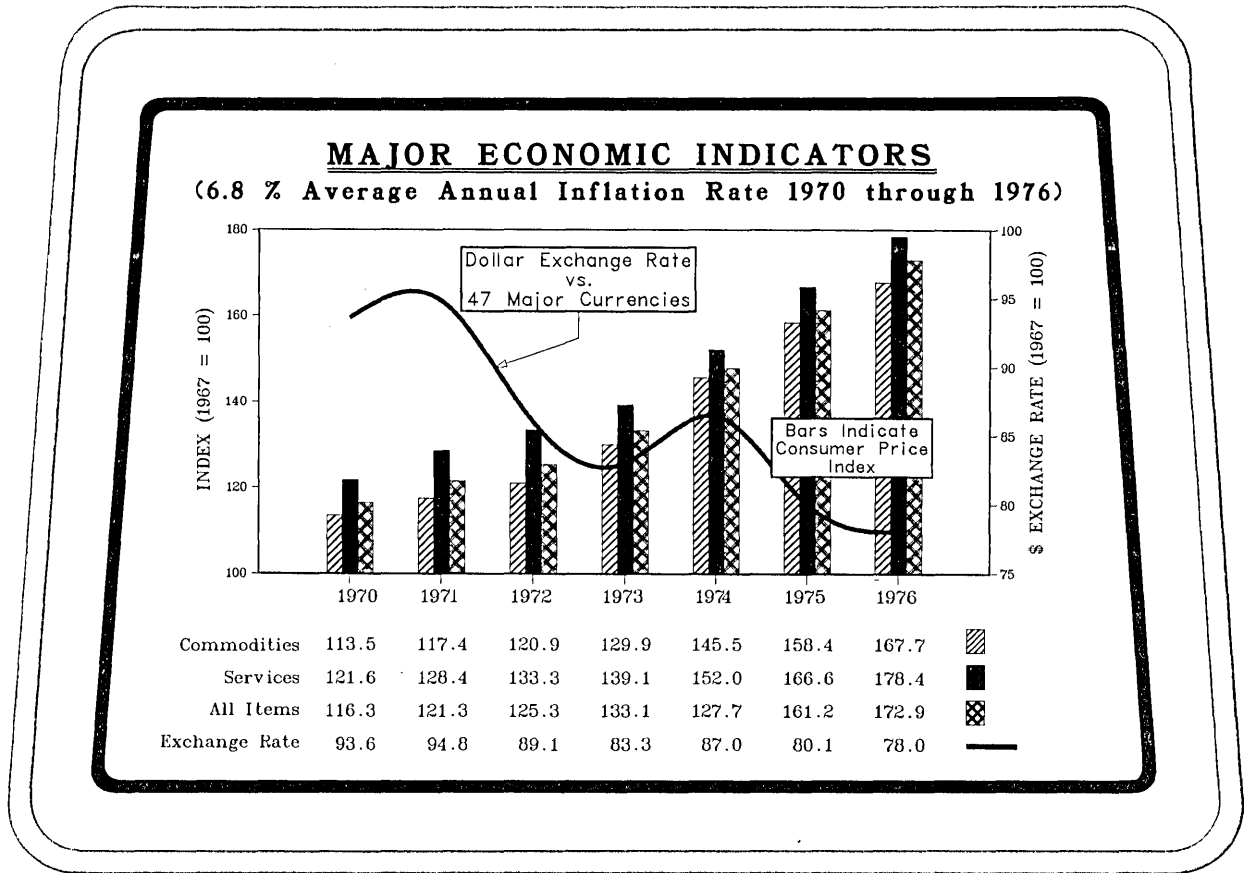

There Is No Better Way To Present Your Data

HIGH QUALITY GRAPHICS

DISSPLA software puts truly professional graphics within reach. No longer is art department touch-up necessary. Total flexibility permits tailoring of XY-diagrams, bar charts, pie charts, maps, 3-D plots, and annotation to all special needs. Graphics for publications, presentations, management reports and internal documentation can be produced quickly and correctly. At last, sophisticated presentation methods can do full justice to advanced analysis techniques.

DEVICE INDEPENDENT

DISSPLA can drive any graphics device whatsoever; our users have Broomall, CalComp, Gerber, Hewlett Packard, Houston Instrument, Xynetics and Zeta pen plotters; Gould, Varian and Versatec electrostatic plotters; DatagraphiX, DICOMED, III, Singer and 3M microfilm recorders; Chromatics, Computek, Tektronix, and Vector General CRT's; and many others. If it can draw a straight line, DISSPLA can plot on it.

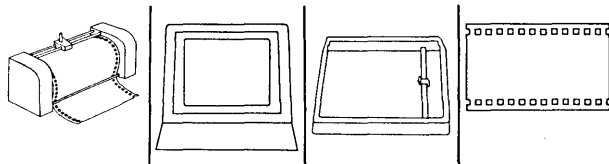

MACHINE INDEPENDENT FORTRAN LIBRARY

DISSPLA is currently operating on all large-scale Amdahl, Burroughs, CDC, DEC, Hewlett Packard, Honeywell, IBM, TI, UNIVAC and XDS systems, plus the Harris midcomputer. The DISSPLA routines may be called from FORTRAN, PL/I, COBOL, ALGOL, etc.

EASY TO USE

High level commands with easily remembered mnemonics, sensible defaults, minimal parameter strings, and clear diagnostics make this available to any user, not only graphics experts. Extensive documentation and user training is provided.

DISSPLA[®]

Display Integrated Software System and Plotting Language
A proprietary software product of ISSCO

ISSCO[®]

Integrated Software Systems Corporation

4186 Sorrento Valley Blvd., Suite G, San Diego, CA 92121 (714) 452-0170

In Washington, D.C.:
Applied Urbanetics, Inc.
1701 K. St., NW
Washington, D.C. 20006
Phone (202) 331-1800

In Europe:
Repko b.v.
van Blankenburgstraat 58
The Hague, Holland
Phone: 070-608425

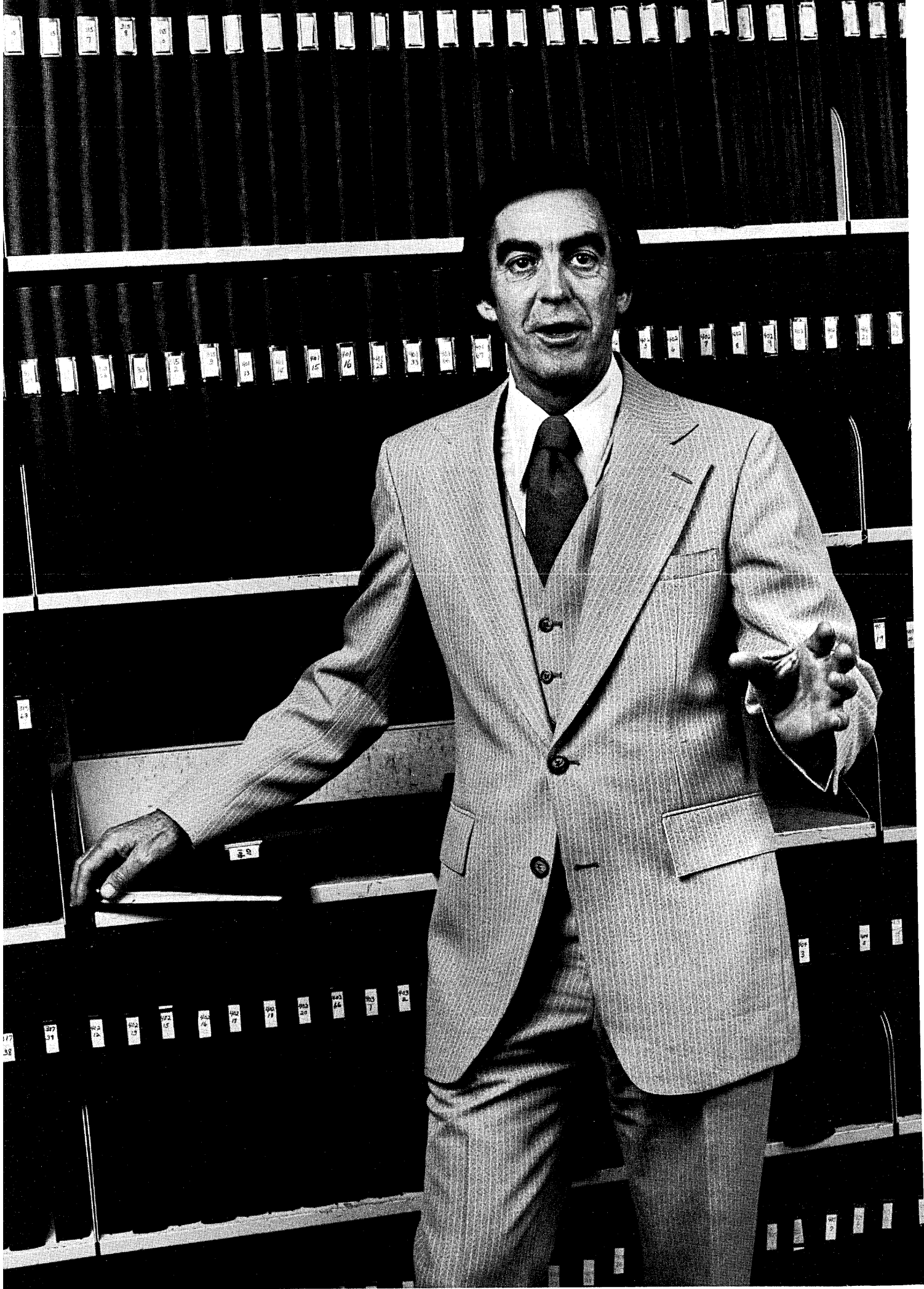

"Our Sycor system gives our salesmen a lot more time to do what they love to do. Sell."

*Floyd Harris, VP
Data Processing
Life of Georgia*

Life Insurance Company of Georgia is the largest insurance company in Georgia. With over \$6 billion of life insurance in force, the company ranks among the top five percent of all life insurance companies in the United States and Canada. Approximately 2300 agents serve the southeastern U.S. from 128 local offices.

"The problem we faced was bookkeeping."

"Many of our agents were spending up to one day per week on bookkeeping," points out Floyd Harris. "Human errors were inevitable, and agents would spend frustrating hours tracking them down. Account reports would arrive at the home office only once a month. And they were really not providing us with all needed information.

"Our Sycor system helped change all that."

"Now our accounts come in every day. And they're complete. Agents are furnished with daily route lists under our new Field Accounting system. This 'fill-in-the-blanks' approach makes data gathering quick and easy. It really helps our agents organize

and manage their work on a daily basis. It also provides us at the home office with complete, accurate information on the status of each policy.

An extra six hours of selling time every week.

"Today every agent is plugged into our Field Accounting system through Sycor distributed processing equipment. And they have more time for selling and training than ever before. One agent in Statesboro, Georgia reports having an extra six hours every week for selling.

"Another thing that really impressed us about the Sycor distributed processing system was

the way it helped boost our agents morale. Freed from the drudgery of accumulated paperwork and the worry about bookkeeping errors, every agent I've spoken to feels a lot better about his work.

A Sycor system is at work in every branch.

"We're so impressed with Sycor that we've installed a system in every one of our 128 branch offices.

"We also plan to utilize more fully each system's capabilities. Like having it handle a branch's accounting functions. And preparing insurance proposals for individual agents where they're needed most. Right at the branch sites."

Call Sycor toll-free at 800-521-2838.

For more information on why a Sycor system is good insurance for productivity and profit, call Tony Fazio, VP Sales, at our toll-free number: 800-521-2838. Or write us at Sycor, Inc., 100 Phoenix Drive, Box D, Ann Arbor, MI 48106.

Better yet, contact a nearby sales office. We're in the Yellow Pages under "Data Processing Equipment."



One of the Sycor systems that help save time and organize work for Life of Georgia agents.

Sycor puts computer power where the work is.™

SYCOR®

A Northern Telecom Company

CIRCLE 60 ON READER CARD

THE OEM'S KEY TO TURNKEY SYSTEMS

Introducing the BTI 5000 Time-shared Computer System. An all-new system offering high storage capacity, fast response, superior operating flexibility, and high reliability.

All at a very affordable price.

For just \$38,950 you get a ready-to-go system with 30 megabytes of on-line storage, magnetic tape cartridge back-up, and eight user ports. For multiple system buyers, there's a very aggressive discount structure, like 30% in a quantity of only 10.

The 5000 is easy to expand...

16, 24 or 32 user ports; 60, 90 or 120 megabytes of disk storage, or more; multiple cartridge tape drives; industry-compatible 9-track magnetic tape; line printers from 300 to 900 lines/minute.

It's easy to program...BASIC-

X, the 5000's extended version of BASIC, is about the best version you'll find for fast development of sophisticated application programs. It includes features like a BASIC-callable, machine-level sort that provides as much as a 30 times advantage in sort times, a big boost

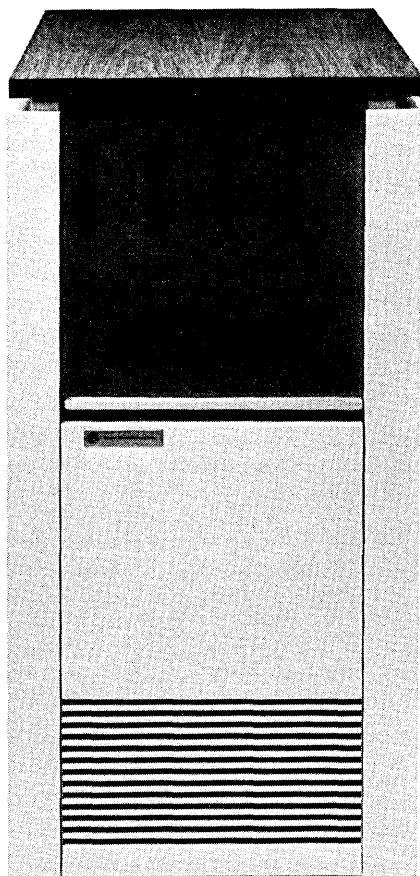

in data base applications.

Your software is protected.

BTI's unique "proprietary accounts" feature lets you install guarded programs on the systems you sell—

with the convenience of dial-up access for maintenance and upgrading.

The operating system is solid.

BTI's highly reliable timeshare executive has been carefully refined in the course of delivering more than 600 systems. It provides the system owner/manager visibility and control over every system operating function.

You don't have to support it—we do. For almost a decade, we have supported every system we've shipped with an all-hours, dial-up diagnostic service. Now we have computers doing this. Automatic periodic health checks uncover potential problems *before* they cause a system to go down. But if a problem should occur, the computer can perform in-depth diagnosis without any help from the customer's people on site.

The new BTI 5000—for the OEM who wants performance, reliability and support, with a margin that's too attractive to pass up. Call us.

 **BTI**
COMPUTER
SYSTEMS

BTI, 870 W. Maude Ave., Sunnyvale, CA 94086. Sales Offices: Cherry Hill, NJ (609) 662-1122; Minneapolis, MN (612) 854-1122; Chicago, IL (312) 298-1177; Dallas, TX (214) 630-2431; Sunnyvale, CA (408) 733-1122; Anaheim, CA (714) 533-7161; United Kingdom; Slough 70044.

EDITOR'S READOUT

ATTACK OF THE GIANT AMOEBA

A gray amorphous blob, looking for all the world like the movie lead in "The Amoeba That Ate Cleveland," is AT&T's diagrammatic representation of its Advanced Communications Service (see cut right).

There's a certain irony to this drawing. ACS, when finally tarified, may have a voracious appetite.

Certainly the service will have a profound impact on the evolution of the data processing field. Users, implementing their own networks, are running into sticky problems handling a variety of protocols, dealing with conversions, and building in a reasonable level of fault tolerance. Because the service will provide nearly universal compatibility between terminal and computer, all the user has to do is plug in. The internal workings of the system are none of his concern; ACS, in the current jargon, is transparent to the user (although "opaque" might be more appropriate).

ACS is not only an announcement of glad tidings for the user, but it will undoubtedly galvanize major segments of the computer industry. Manufacturers of terminals and network-oriented software and services should be rubbing their hands in glee. It's their products that will be festooning ACS like ornaments on a Christmas tree.

And, can it be a coincidence that ACS extended its first pseudopod just at the time when communicating word processors, electronic mail, and fax are coming into their own? All other attributes aside, ACS must rank as one of the most masterful marketing ploys since the introduction of the 360.

That's the good news. Now for the other side of the coin.

We don't know what ACS is going to cost. We do know that tariffs are not



determined using real numbers that reflect development and projected operating costs. No, rather there is some mystical process during rate making and tariffing that closely resembles divination by tea leaves or casting the I Ching. If the rates are too high, the benefits mentioned above may not materialize.

Another stumbling block is the hearings on rewriting the Communications Act of 1934. Because Congress appears fonder of hearing than doing, the new version—and Bell's prerogatives under it—may be off in the misty future.

Amoebas, we are told, have contractile vacuoles wherein they digest

their food. Private packet switched networks, such as Telenet and Tymnet, may be the first course on the ACS blue plate special. Other delicacies will be the various networking configurations from the mainframe vendors—DECnet with oyster sauce, BDLC on toast, and brisket of SNA.

Free enterprise organizations will stand little chance against a regulated monopoly that can wield the weapon of cross subsidization.

Also in trouble are the modem manufacturers and other makers of black boxes that will disappear into the innards of the system.

Even the U.S. Postal Service may take its lumps as low cost electronic mail becomes a reality.

So it appears that ACS will be a boon to some and a blight to others. But at this point it's too soon to judge its impact and predict when the service will become a reality.

In the meantime, users we have contacted who are considering or are in the process of implementing their own dedicated network are moving ahead with their plans. When the ACS amoeba finally does appear over the horizon, they'll take another look and decide if they want to be engulfed in its friendly embrace. *

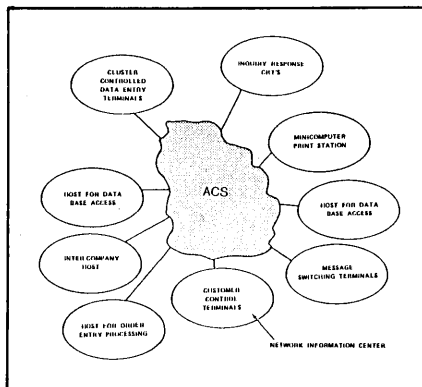

Introducing DECSYSTEM-2020 full-function APL.

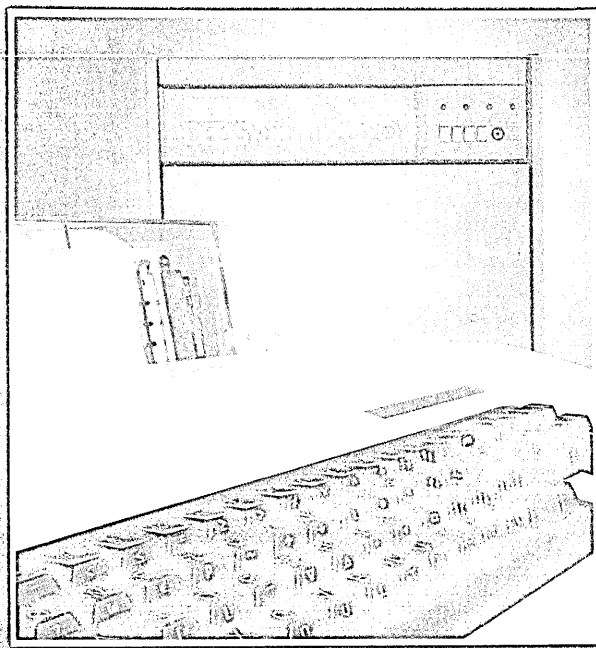

In the world's lowest cost mainframe APL system.

It took the world's lowest cost mainframe to configure the world's lowest cost full-function APL package. The new DECSYSTEM-2020 APL System. Just \$199,500.

Based on a five year system life, that works out to less than half the cost of outside APL services.

And compared with other systems offering a similar level of APL functionality, the new DECSYSTEM-2020 package comes in, incredibly, at about *one-fourth* their cost.

For \$199,500, here's what you get:

- DECSYSTEM-2020 Mainframe CPU;
- 4 APL Terminals with Full APL Character Set;
- Complete APL Software;
- TOPS-20 Virtual Memory Operating System;
- One Megabyte of Main Memory;
- 67 Megabyte Disk Drive;
- High Speed Tape Drive.

With the DECSYSTEM-2020, you really do get full-function APL. The same APL that runs on our largest DECSYSTEM-2060

mainframe, recognized as being among the best in the industry. It comes complete with features like an extended file system, divide-quad functions, error analysis and recovery, and dyadic format function.

You also get all the features and benefits that are making the DECSYSTEM-2020 one of the hottest mainframes to hit the market in years.

Things like surprising ease of use, thanks to its fully developed interactive mainframe software, comprehensive system utilities, and specially designed architecture. And unmatched ease of upgrading that allows you to move up through the entire DECSYSTEM-20 family of mainframes without ever giving up your investment in software.

The new DECSYSTEM-2020 APL System.

For DP Managers, the world's lowest cost.

For APL users, everything they want, in their very own mainframe.



All Digital mainframe systems are now available to qualified OEMs.

digital

Please send your new 24-page color brochure, **DECSYSTEM-2020—the World's Lowest Cost Mainframe.**

A-9-8

Please contact me.

Name _____
 Title _____
 Company _____
 Address _____
 City _____ State _____ Zip _____
 Telephone _____

Send to: Digital Equipment Corporation, MRI/M-49, 200 Forest St., Marlboro, MA 01752. Tel. 617-481-9511, ext. 6885.

The Data Communications Systems Of The Future

We're looking ahead to the data communications systems of the future. It's part of our determination to stay ahead in computer communications. To deliver systems today that stay with you as your computer communications grow.

We see more use of computer networks for the future. Networks linking far flung terminals with central or regional computer sites. Providing improved access to vital data. Making more efficient use of your computer facilities. These networks will require a new generation of communications processors. More intelligent and powerful front-end processors. More powerful and efficient remote communications concentrators. Front-end processors that will have greater throughput, will operate at faster speeds, and will relieve

host computers of more communications tasks. Able to access multiple CPU's while handling thousands of terminals. Remote concentrators more powerful to handle maximum transmissions speeds. Able to operate with conventional lines and satellite channels. Speeding the flow of data while saving line costs.

When it comes to computer communications, keep your eye on CCI. We're already working on the technologies of the future. We're looking ahead in computer communications to keep you ahead.



2610 Columbia Street, Torrance,
CA 90503. (213) 320-9101.

We're Looking Ahead In Computer Communications.

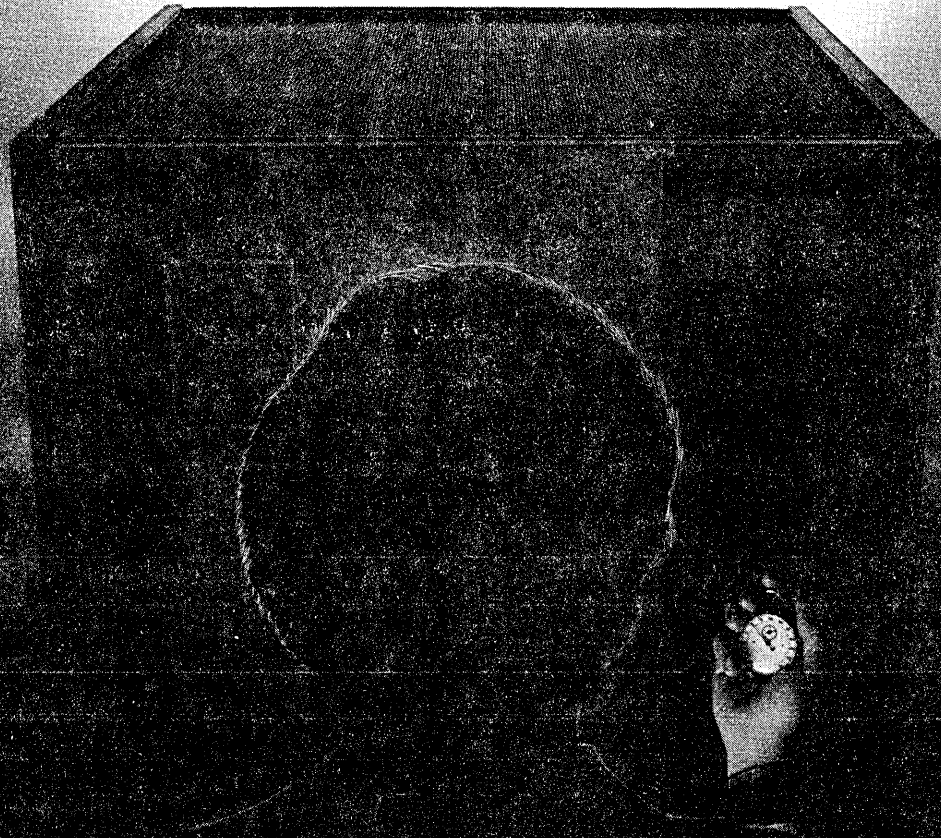



Omron's 8038/UET terminal is totally compatible with Uniscope® 100/200

The 8038/UET plugs directly into the Univac Multiplexer or through direct connection to the host. Or it can operate as a remote terminal with Auto Answer.

Omron's 8038/UET is fully compatible with Univac software and offers these significant features, as standard:

CRT DISPLAY

8x10 in.: 15 in. diagonal.

Display format

7x7 matrix, upper case and numerics; 7x9 matrix, lower case, standard.

Character size

.23x.1 in.

Page format

80 characters per line, 24 lines per display, 1920 characters per screen.

Character set

128 characters ASCII.

Video display

8 video attributes. Escape sequences permit host to access extended features.

KEYBOARD

1/0 code. ASCII (standard).

Arrangement ASCII (standard).

Numeric pad

12-key including decimal point and comma.

Cursor pad

Non-destructive blinking underscore.

EMULATION

ENHANCEMENTS

- 10 function keys vs. 4.
- Backward Tab function.
- Automatic protected format.
- Line insert/delete keys.
- Communications line data display.

Priced at \$2,900 in small quantities, the 8038/UET is a natural for the cost-conscious Uniscope user. For detailed specifications and technical literature write or call Information Products Division, Omron Electronics, Inc., 432 Toyama Drive, Sunnyvale, CA 94086. (408) 734-8400.

- Self-test diagnostics.
- Keyboard programmable RID, DID, SID.
- Keyboard selectable Synch or Asynch operation.

EDIT FUNCTIONS

Complete U-100/U-200 editing features are supported.

DATA RATE

To 9600 baud. Asynch-synch.



for a universe of exceptionally reliable CRT systems.

NEWS IN PERSPECTIVE

PROCUREMENT

CSC'S HUGE HEALTH CONTRACT

After 12 years, California finally lets a competitive bid for Medi-Cal processing.

The State of California never has been comfortable with the contract it awarded in 1966 to Blue Shield and Blue Cross to process the state's Medi-Cal health care claims. Medi-Cal, which is the state's version of the national Medicaid plan to provide health services to the poor, today generates claims that run to about \$3 billion a year.

Last month, after 12 years of wrangling among state government agencies concerning profiteering by Electronic Data Systems of Dallas which did the data processing part of the contract, the state was preparing to bounce Blue Shield and EDS from the picture.

In the biggest contract it's ever awarded, California's Department of Health Services turned the job over to Computer Sciences Corp., the Los Angeles computer services firm, under a 5½ year contract worth \$129 million.

Under the contract, CSC will act as the state's "fiscal intermediary," using computers to inspect the estimated 175,000 claims a day that flow in from doctors, pharmacies, hospitals, and clinics and then verify the claims and establish the amounts due. It then will provide the state with the amounts to be paid by the state's controllers' office. It also will provide the state with management, administrative, and utilization reports that will enable the state to monitor and audit the Medi-Cal program.

Gregory Thompson, who directed the massive 11-month procurement for the California Department of Health Services, said the state will save from \$20 million to \$30 million a year under the new contract. CSC was one of five companies that submitted technical proposals to Thompson and was one of the three whose proposals were accepted in the two-step procurement process. The others were Blue Shield Services Corp., which co-bid with EDS, and Bradford National, of New York, which recently won a similar contract to process claims in New York. (Blue Cross did not bid.) The second step in the procurement for the three finalists was to submit sealed bids on their price. Computer Sciences won with a bid of \$129,599,728. It was followed by the Blue Shield-EDS bid of \$133,899,161, and Bradford National's



DR. MARIO I. MONTANA—In the ballpark with the incumbent.

bid of \$159,720,022.

Bradford's executive vice president, Howard Waltman, said his company's bid, which was \$30 million higher than the winner, simply was based on his company's "experience and consistent with our corporate profit objectives."

Dr. Mario I. Montana, president of CSC's commercial division, said, "after all, our bid was in the ballpark with the incumbents' bid."

The incumbents—Blue Shield and Blue Cross—were asked by the state to act as a fiscal intermediary in 1966 when Congress rushed through legislation creating Medicare and Medicaid, the lat-

When the Blues became bogged down with unprocessed claims, they turned to EDS.

ter providing care for welfare recipients. But soon afterwards, the Blues became bogged down with a staggering backlog of unprocessed claims and were taking months to pay the health care providers. In September 1969, California Blue Shield turned to Electronic Data Systems Federal, a subsidiary of Electronic Data Systems, of Dallas, formed by H. Ross Perot, the multimillionaire who used to sell computers for IBM. A subcontract was signed to allow Perot's computers to be used to process the backlog of California claims, and EDS cleaned it up in short order.

But there were persistent rumors that the Dallas firm was profiteering on the subcontract. In the first year, EDS refused to repay more than \$250,000 in admitted

overcharges to the state. In 1972, there were demands in the California legislature that the contract be renegotiated and later California launched a pilot project with four private insurance companies to see if the state could handle its own Medi-Cal business. After the pilot project was completed, it succumbed to intense lobbying pressure, both in the legislature and the administration.

EDS' president Milledge Hart accused the pilot project of "flushing" claims, that is, paying off the claims without verifying their authenticity.

Gregory Thompson looked at the contract and gasped.

In 1975 Gregory Thompson, a former computer specialist with United Aircraft and Honeywell Information Systems who had become a lawyer specializing in contract law, joined the California State administration of Gov. Brown. Thompson looked at the Medi-Cal contract and gasped. "Here was the state's biggest outside contract and it seemed to be locked into a single organization with nobody else having a chance to bid on it," he recalled recently.

Indeed no one could bid. Although the contract with the Blues had expired Dec. 31, 1966, it contained a provision for automatic extension every 30 days, unless either of the two parties gave 60 days written notice to void it. And it had been extended every month for nearly 12 years.

Last October, Thompson issued a 1,000 page request for proposal on a new competitive bid.

The timing was excellent.

As bidders were preparing for the March 6 deadline, a special Assembly subcommittee of the state legislature was doing its homework. It issued a report in February charging that the state had been overpaying EDS by 20% to 30% ever since the company took over claims processing in 1969. For example, the report said that before the EDS subcontract, Blue Shield's administrative charges were \$10.4 million a year. During the first full year of operations under the EDS arrangement, Blue Shield's administrative expenses rose to \$19.3 million—an increase of 85%.

The report said the increase was alarming because EDS had been brought in to reduce "or at least keep the lid on costs." And although the company had raised the average number of claims processed to 2.8 million from 2.1 million a month, the report said the higher figure continued even after the huge backlog of 1.3 million claims was reduced. It said 61% of Blue Shield's overall administrative expenses was directly attributable to



BIG BID—csc submitted 14-volume proposal and an 80-ft. long flow chart, viewed here by csc's Dr. Montana and Ross Forncrook, who heads csc's health services operation.

electronic data processing.

The report also charged that in addition to receiving 20 cents for each claim it processed, EDS had a clause in its contract that gave it half of the amount by which it

Tiny Richmond firm was a key subcontractor in many winning proposals.

was able to reduce the average cost of each claim. And it was allowed to give a definition of what constituted a claim that raised the number of claims for billing purposes by 30%, the report said.

And until 1977, there was no way to audit Electronic Data's portion of the contract. When Congress passed a law in 1977 allowing such audits, much of what the subcommittee presented in its report was substantiated, but the head of the Joint Legislative Audit Committee, Mike Cullen, reported that EDS was the only company able to provide such services.

EDS criticized Thompson's bid proposal because it gave the state all rights to the software, which EDS claimed to be an industrial secret, even though it was developed at taxpayers' expense. The

Dallas concern also protested to the Health Department's Medi-Cal division that the bidding process "denies EDSF its earned natural advantage as a successful operator of the Medi-Cal claims processing system." But when the division rejected these claims on the basis that any changes in the bidding procedure could result in the loss of federal money for the state in future years, EDS withdrew its objection.

Thompson says the request for a technical proposal was made so elaborate because "we wanted everyone to know we were serious," and that after so many years of month to month renewals, the state actually wanted a competitive bid. Computer Sciences, who co-bid the contract with The Computer Company, a Richmond, Va., service bureau with experience in Medicaid claims processing, delivered 35 copies of its proposal to Thompson's office—each copy consisting of 14 volumes and an 80-foot long performance flow chart. The whole package weighed a ton and a half.

Thompson's office spent five months reviewing the proposals. A full-time staff of 50 persons from the Department of Health Services and staffers from the Seattle management consulting firm of

Compass Management approved the technical proposals. All that was left was the price.

Although some staffers at Bradford National privately have questioned csc's ability to perform the contract at a profit, the company formally said it has no argument with the way the two-step procurement was handled. "Looking back, I would say the State of California ran the

"We wanted everyone to know we were serious."

procurement professionally," says Bradford's Mr. Waltman.

Ironically, Bradford won the New York Medicaid bid last year in a proposal in which it subcontracted with The Computer Company for the claims processing system. In the California bid, The Computer Company is a subcontractor with csc. The relatively small firm, with 325 employees and about \$10 million in revenues last year, also was the subcontractor to Systems Development Corp., which won a contract to handle Florida State's medicare processing.

Ross E. Forncrook, vice president and general manager for health services with Computer Sciences, says The Computer Company was selected by csc because the State of California asked csc to come up with an operating system "that we could add to or modify." And the Richmond, Va., firm's system was certifiable by the Department of Health, Education and Welfare, meaning that the Feds will pick up 90% of California's startup costs on the system and 75% of its operating costs. (The Computer Company also serves directly as a fiscal intermediary in Virginia, Delaware, and North Carolina.)

csc will use dual IBM 370/158s to process the more than 200,000 pieces of correspondence that will come to it when it implements the system fully 18 months from now. (California will continue to use the Blue Shield-EDS services until that time.)

Of these 200,000 documents, the company estimates that 175,000 will be claims that will be microfilmed, then entered either through an on-line data entry or ocr system. It estimates that around 40% of the claims can be processed by ocr. It said its system operates a COBOL Medicaid Management Information System, that provides two key reporting systems to the state: One is a Management and Administrative Reporting Subsystem that will provide statistical information on how the claims are being administered; and the other is a Surveillance and Utilization Review, which mainly will be used to alert the state to providers or recipients who might

be abusing the Medi-Cal program.

In cases where errors or irregularities are found, the csc system will recheck the documents in the software, not manually. If a document must be returned to a provider for clarification, it will be sent as a reentry document, not as an original one, for automatic processing when returned.

The company will hire about 1,000 persons to staff a claims processing office in Sacramento where it also will provide training to providers on how to file claims properly. It also will use training mobile vans that will fan out over the state showing physicians and their assistants how to file a claim accurately.

"But," says Montana of csc, "we're not going to turn them into computer people. After all, they're providers of health care, not employees of computer firms."

-Tom McCusker

AIR FORCE'S PHASE IV BUY

Huge procurement has a novel approach in which software conversion takes priority.

Picture this: A computer contract over a long lifetime that would be worth more than the annual sales of any computer company in the world, with the exception of IBM.

That would have to be the United States Air Force at work and the contract is called the Base Level Data Automation Program (Phase IV) acquisition. While the Air Force's cost analysis of the program is a tightly held secret, reliable sources say the total cost of the program over a 20-year period could go as high as \$4 billion. Informed sources placed the total acquisition cost at \$500 million.

The initial hardware buy would likely be between \$210 and \$260 million—and that by itself is high enough to qualify as the largest single acquisition of computers ever. Phase IV's request for procurement (RFP) is scheduled to go out in December and the computers are slated to be finally installed by the end of 1983.

According to an Air Force description of the Phase IV program, the first objective of the program would be to "extend automated data processing support to base level users through the year 2000 by competitively acquiring upgradable/expandable hardware from a single con-

tractor's series of software compatible automated data processing equipment."

Essentially, the Phase IV acquisition would replace a total of about 250 computers the Air Force currently uses in installations around the world for routine data processing applications. The systems to be replaced are Univac 1050-11s, and Burroughs 3500/3700/4700s.

"My guess—and it's just a guess—is

"We're looking for normal technology gains."

that we would end up with about the same number of computers in Phase IV," said Col. John Gioia, Phase IV program manager. "It's going to be up to the industry, which can configure Phase IV anyway it wants. We're looking for normal technology gains. We are seeking to keep up with the computing state of the art."

Even as Col. Gioia spoke, however, there was speculation among vendors examining the Phase IV draft RFP that some of the larger minicomputer firms might join in the bidding against large mainframe companies. Digital Equipment Corp., for instance, is known to have a team examining the Phase IV RFP with an eye to submitting a bid. Minicomputer companies could be expected to bid more of their smaller machines against the large mainframes.

The Air Force is taking a somewhat novel approach to the procurement in that the problem of software conversion will be faced first and before the hardware contract will be awarded.

"Two contractors," the Air Force Phase IV program description states, "will be competitively selected to perform the software transition and design their adp system. These two systems will be tested and a production option would be exercised with one of the contractors to implement his system worldwide."

Procurement for Phase IV will be carried out by the Air Force's Computer Acquisition Office at Hanscom AFB in Bedford, Mass.

One key idea of Phase IV is to inject competition into the selection of the base level computers by opening up the entire contract to competitive bidding rather than to permit individual Air Force bases to replace their saturated computers a few at a time by different vendors.

The 20 year system life of Phase IV, however, is certain to raise eyebrows because some vendors are sure to charge that it represents a de facto sole source contract. "Whoever doesn't win the contract," said one vendor's Washington representative, "is sure to complain that Phase IV is a sole source contract and, as such, not really competitive."

The problem is that once a final winner has been chosen for the production contract award, only he is likely to be able to continue to supply hardware, software, and hardware maintenance for the duration of the 20 year contract.

In an attempt to inject competition into the contract for as long a time as possible and to monitor the award, the Air Force plans to use what it calls a "rolling" contract concept.

"The initial production contract option will cover an eight year period," the Phase iv report states. "At approximately year five of that option, the Air Force will provide workload data for the next six year period following contract expiration. The contractor will then propose new prices and/or new technology for use during the new period. The Air Force will evaluate the contractor's proposal to determine what action should be taken. This 'rolling' concept would be used to satisfy the 20 year systems life.

"... The strategy is to acquire an adp system—the hardware, basic software and transitioned software—and to maintain competition as long as practical."

The software conversion part of the

program—called the transition contract award—specifies that the Air Force select the two most likely candidates and give them 18 months to prepare conversion software. Since the current base level computers are about evenly divided between Univac and Burroughs, those two vendors presumably would have something of a head start on the software conversion.

It will select the two most likely candidates and give them 18 months to prepare conversion software.

The two chosen vendors each would be reimbursed for their software conversion work, and, finally, a "compute-off" between the two would be held and a winner for the production contract award would then be picked.

The Phase iv report states: "The test and evaluation process will evaluate contractor responsiveness to Air Force requirements; use of established standards, and acceptance testing will insure that each system delivered by the contractor

meets contract provisions."

Since both the Univac and Burroughs machines use myriads of applications software programs unique to each vendor's machine—much of the code is written in each machine's assembly language—the software conversion program is likely to be a challenge. While the Air Force has no public cost analysis figures available, one potential bidder who has studied Phase iv believes the software conversion award could amount to as much as \$50 or \$60 million.

When asked whether the total 20 year cost of Phase iv could surpass \$4 billion, Col. Gioia declined to comment. He noted, however, that the lion's share of the cost of the program over the years would come from overhead and operating costs including facilities modifications and power requirements. Col. Gioia emphasized that it would cost more over the next 20 years to operate the Air Force's existing base level computers than it would to operate the proposed Phase iv computer. Thus, he said, Phase iv actually will represent a saving.

—W. David Gardner

HOW THE AIR FORCE BUYS COMPUTERS

While the U.S. military complex receives its share of publicity for squandering public funds and for cost overruns, a new Phase iv computer procurement program will undoubtedly bring the Air Force's Computer Acquisition Center into sharp focus. Moreover, Col. Robert J. Latina, commander of the center, believes his operation will stand up to the close scrutiny.

"We usually get 35 to 40 percent off the commercial price of the equipment we procure," says Col. Latina. "I think that's significant."

The U.S. Air Force is the largest user of computers in the world and the biggest chunk of its equipment is procured through the Computer Acquisition Center. Procurements run the gamut from the enormous Phase iv program—with its estimated \$500 million total acquisition cost—to smaller \$300,000 or \$400,000 contracts.

"We signed contracts valued at over \$100 million over the past 14 to 16 months," says Col. Latina.

Established more than 10 years ago to acquire commercially available off the shelf computer gear, at least partially in response to the Brooks Bill, the computer acquisition center today has some 90 employees, including 68 professionals. The center employs hardware and software specialists, some of whom develop benchmark tests that must be successfully run before vendors are awarded contracts.



COL. ROBERT LATINA—"It's bad when we get just one bidder."

Does the center have any problems acquiring computers?

"Our biggest problem is software conversion," says Col. Latina. "It's not always recognized as being as big a problem as it is. We would like to see more software converted before hardware is bought.

"You must convert the software before a new hardware buy or after, and I'd rather do it before I buy a machine. In the end, it's a cost tradeoff: will it cost me more to convert the software and to get the benefits of competition?"

On the subject of competition, Col.

Latina said the basic charter of the center is to encourage competition among suppliers of commercial edp products in Air Force data processing procurements and "to let the free enterprise system work."

"We are after off the shelf commercial products," said Col. Latina. "While the industry is moving very rapidly in a technology sense, we know pretty much where it is and our requirements are never that exotic. We're not in the business of developing computing equipment."

The procurement process begins once an Air Force agency has been given funding approval for a computer project. The user specifies to the center the general type of equipment it wants and the type of application for which it will be used. The center then issues an RFP for the contract, vendors respond with proposals and, usually after a pre-award test demonstration designed to show that the vendor can perform the job, bids come in.

"The best thing that can happen," says Latina, "is for us to get four or five bidders. It's bad when we get just one bidder and worst of all is when we get no bidders at all."

Occasionally a contract award is protested by a vendor. Latina said that seven awards were protested to Congress' General Accounting Office in the past 12 months and that all were denied as being "without basis." *

SERVICES

SERVICES TURN TO MINIS

Service firms will have installed about 7,500 by end of next year.

The \$7 billion a year service bureau industry has apparently decided that if you can't beat 'em, you might just as well join 'em. By the end of 1979, some 160 U.S. service firms will have installed 7,500 mini and microprocessor systems at customer sites.

This is one major finding of the recently published annual survey of the industry from the Association of Data Processing Service Organizations (ADAPSO).

The number of installations actually could be higher because the 160 firms represent only half of the 309 bureaus, software firms, and professional services companies that responded to the ADAPSO survey. The 309 companies represent 38% of the industry's revenues and 10% of the estimated number of companies in the market.

Why get on the mini bandwagon? Most of the processing services respondents say that some of their business (30% average) is vulnerable to takeover by in-house installation of small systems. Exposure, they say, starts with customers spending over \$1,000 a month, although

as costs decline, some expect this figure to dip to \$500. General business services and firms specializing in just one or two industries are most vulnerable (50% to 100% of business).

The threat to processing services diminishes as the size of the company increases, partly because of the size and complexity of the accounts and partly because of the ability to market and support these mini systems where needed. NCSS, Keydata, and ADP have already jumped in with both feet. The smaller firms, however, feel they can also take advantage of the declining costs of these systems and begin offering services, such as remote processing, that they have not been able to afford. And, experienced with the small company account, they also have an opportunity to support or manage the small in-house system—in what the survey calls mini-facilities management.

The software firms (which recorded a whopping 36% growth in 1977) and professional services generally see enormous

Mergers and acquisitions may gather momentum as business is lost to in-house installations.

opportunities in minis for software packages, support, and mini-facilities management.

What this industry might experience, say the respondents, is another weeding out of the "weak," who cannot respond

to technological and market change. Mergers and acquisitions may gather momentum because of the need to expand products and markets in order to grow and to counter loss of business to in-house installations.

But the industry will not see a flattening growth overall by any means, according to the ADAPSO survey, conducted by Input Inc. It estimates "conservatively" that U.S. business in all services sectors grew 19% to \$6.3 billion—\$7 billion, if captive and non-U.S. business is included. In fact, the 309 respondents themselves actually recorded a 28% growth in 1977 over 1976. (The 19% figure was derived from extrapolations on how the remainder of the estimated 3,000 firms, most of them \$2 million and under, performed.) Further, almost all sectors and all size categories grew more in 1977 than firms had projected the previous year.

ADAPSO and Input are both estimating that between 1978 and 1982 the industry will grow at an annual rate of 16% to 17% and reach about \$15 billion in 1982. Software products firms will lead the pack at 29% a year, followed by processing services (17.4%), and professional services (9.2%).

Besides mini-microprocessor trends, the services firms noted other developments that were mixed blessings. A worsening shortage of skilled labor and increasing wages were noted by many, particularly smaller services companies. But this problem also represents opportunities for them, as users seek more effective ways to develop applications.

RESPONDENTS' PROJECTED MINICOMPUTER INSTALLATIONS AT CUSTOMER SITES

TYPE/SIZE NO. OF COMPANIES IN CELL	NO. OF INSTAL.	MINICOMPUTERS INSTALLED					
		1977		1978		1979	
		MAXIMUM*	NO. OF INSTAL.	MAXIMUM*	NO. OF INSTAL.	MAXIMUM*	
PROCESSING SERVICES							
<\$2M	133	219	45	565	150	1,231	250
\$2-10M	46	486	160	835	300	1,705	600
\$10-25M	11	216	185	392	335	527	375
>\$25M	16	1,171	1,000	1,692	1,200	2,732	1,500
SOFTWARE PRODUCTS							
<\$2M	45	107	23	227	45	424	100
\$2-10M	10	6	3	45	15	180	100
>\$10M	5	11	10	35	20	125	100
PROFESSIONAL SERVICES							
<\$2M	29	56	20	141	40	349	100
\$2-10M	10	76	40	141	60	226	90
>\$10M	4	11	8	20	15	58	50
TOTAL	309	2,359		4,093		7,557	

*MAXIMUM ANY SINGLE RESPONDENT SAID IT WOULD INSTALL

SOURCE: ADAPSO and Input, Menlo Park

**PUBLISHED RESULTS OF PUBLIC
COMPUTER SERVICES COMPANIES**

COMPANY NAME	FISCAL YEAR END		1977 (IN MILLIONS)	1976	% GROWTH 1976-1977		% PROFIT ON REVENUES
ANACOMP	6/30	R	\$ 16.18	\$ 12.85	25.91%	76	12.37%
		P	2.47	1.59	55.35	77	15.27
APPLIED DATA RESEARCH	12/31	R	16.93	12.91	31.13	76	15.26
		P	3.03	1.97	69.27	77	17.90
AUTOMATIC DATA PROCESSING	6/30	R	245.49	199.24	23.21	76	18.56
		P	45.97	36.98	24.31	77	18.73
BRADFORD NATIONAL	12/31	R	80.61	65.80	22.50	76	8.62
		P	6.05	5.67	6.70	77	7.51
BRANDON APPLIED SYSTEMS	2/28	R	7.59	5.81	30.64	76	—
		P	0.59	(0.94)	—	77	7.77
COMPU-SERV	12/31	R	14.33	11.40	25.70	76	13.95
		P	1.66	1.59	4.40	76	11.58
COMPUTER SCIENCES CORP.	3/31 (FISCAL 1978)	R	276.91	234.75	18.00	76	4.95
		P	13.88	11.64	19.00	77	5.01
COMSHARE	6/30	R	18.21	13.76	32.34	76	9.38
		P	2.27	1.29	76.00	77	12.47
ELECTRONIC DATA SYSTEMS	6/30	R	164.18	132.95	23.49	76	20.03
		P	28.51	26.63	7.06	77	17.37
KEYDATA	6/30	R	14.47	14.88	(2.76)	76	10.95
		P	0.35	1.63	(78.53)	77	2.42
NATIONAL CSS	2/28	R	41.70	35.60	17.14	76	12.33
		P	5.48	4.39	24.83	77	13.14
NATIONAL DATA CORPORATION	5/31	R	34.99	32.95	6.19	76	9.92
		P	4.16	3.27	27.22	77	11.89
ON-LINE SYSTEMS	4/30	R	16.00	11.96	33.78	76	11.37
		P	2.27	1.36	66.91	77	14.19
QUOTRON	12/31	R	33.35	24.64	35.35	76	17.78
		P	7.58	4.38	73.06	77	22.73
RAPIDATA	12/31	R	17.91	15.62	14.66	76	5.12
		P	1.84	0.80	130.00	77	10.27
SHARED MEDICAL	12/31	R	45.69	35.47	28.81	76	26.14
		P	13.27	9.27	43.15	77	29.04
SYSTEMS DEVELOPMENT	6/30	R	130.09	109.94	18.33	76	3.88
		P	4.86	4.27	13.82	77	3.74
TYMSHARE	12/31	R	101.17	81.83	23.63	76	16.08
		P	15.81	13.16	20.14	77	15.63
TOTALS		R	\$1,275.80	\$1,052.36	19%*	76	13%*
		P	\$ 161.05	\$ 129.02	25%*	77	14%*

*WEIGHTED AVERAGES

R = REVENUES (GROSS)

P = PROFITS (BEFORE TAXES & EXTRAORDINARY ITEMS)

EIGHTEEN public computer service firms earned \$161 million on total revenues of \$1.2 billion in 1977, an increase of 25% over 1976. Figures are taken from recently

published report on the industry by Assn. of Data Processing Services Organizations.

**COMPUTER SERVICES COMPANIES' GROWTH PROJECTIONS
1977 TO 1983**

TYPE OF COMPANY	FORECAST 1976 TO 1977	RESPONDENTS TO SURVEY		FORECAST FOR NEXT 5 YEARS
		ACTUAL* 1976 TO 1977	FORECAST 1977 TO 1978	
PROCESSING SERVICES	16.4%	27.0%	19.5%	17.4%
SOFTWARE PRODUCTS	27.2	36.0	22.6	29.1
PROFESSIONAL SERVICES	20.1	29.0	9.9	9.2
WEIGHTED AVERAGE ALL COMPANIES	17.2%	28.0%	18.8%	17.1%

*Actual reported growth includes sources other than U.S. available revenues, such as acquisitions and revenues from foreign expansion. Therefore, these growth rates are overstated when compared to the actual 1976 to 1977 growth estimated to have been 19% for the total industry. (Source ADAPSO and Input, Menlo-Park.)

With their concentrated expertise, all services companies will be giving much more attention to new programming techniques and to standardized systems and applications packages. The survey projects an explosion in the development

Printing and publishing are ripe for communications-based services.

of implementation languages and data base management systems.

The larger services firms are impacted by the decreasing cost of large mainframes, particularly the IBM compatibles. But while the customer may move more applications in-house because of this, the service company also can increase capacity, switch the savings to much-needed product development, and/or offer more for the dollar.

The hardware expenditures (processor and peripherals) is already dropping for service bureaus, from an average 22% in 1977 to 18.5% of costs in 1978. It is down to 12% for large firms.

While some large firms are worrying about the battle between IBM and AT&T over communications-based services—and the prospect of being squeezed out—they also see growing new markets. In the next five years the value-added network services for data, text, message handling, video and facsimile will take off, says ADAPSO. In the 1980s, electronic mail, distributed data processing, and data and information bases will become major growth markets. Printing and publishing “are ripe” for communications-based services.

The survey generally concludes that distributed data processing will not be fully implemented by computer users

until the 1980s, and the implementations will not be as extensive as currently envisioned. But in the '80s, large service companies will find major business in providing distributed processing networks for medium and large firms. The need for support from professional service companies will be enormous, and software producers will be building a vast new crop of application packages and systems products.

Among all firms, but particularly among the medium-size services companies, industry specialization will be the byword of the next few years. This is not unlike prognostications of 10 years back, but specialization will be across an increasing number of industries and me-

dium firms are expected to expand out of their regional markets. Banking and finance leads the pack as the most important and growing sector for software and services. Wholesale, retail, discrete and process manufacturing are other major growth markets. (The list was longer as the size of firms responding increased.)

Non-U.S. markets are seen as another growth opportunity. Among responding processing services companies, more than \$130 million came from abroad—7% of their total reported revenues. Most of that, of course, was raked in by firms with \$25 million-plus revenues. Software companies, which have long exported their packages into Europe and elsewhere, realized 17% of their revenues from abroad (\$36 million). Professional services abroad accounted for \$28.7 million or 7% of respondent revenues.

Europe alone saw U.S. service firms penetrate 10% of its \$2.9 billion market in 1977. IBM, which is not included in the survey, has another 5%. That market has been growing at 15% a year, and more and more U.S. service companies are eyeing it.

The problems and opportunities—minis/micros in particular—are similar in Europe, as are the service company answers to them. But the Europeans are also keeping their eyes on the U.S. opportunists, and taking many steps to counter their growing competitive threat. These include making incursions into the hyperactive U.S. market. That does not arise as an issue in the 1977 ADAPSO survey, mostly because it is a fledgling trend. But it will.

—Angeline Pantages

COMMUNICATIONS

CUT-RATE SERVICE

U.S. data communications users would be offered rates at savings of 50% for private line service to Europe.

Drastically reduced rates for 1200 to 9600 bps private line service to Europe probably will be offered by U.S. international record carriers (IRC's) before the end of this year. The savings would amount to nearly 50% in some cases.

Most U.S. users who have to communicate with Europe at 1200bps and higher speeds now use analog alternate voice/data (AVD) circuits. From the East Coast, the present “half-circuit” charge for this service is \$4,545 a month. (The

half-circuit extends from the U.S. IRC's gateway, where it interfaces with the subscriber's access line, to the midpoint of the Atlantic, where facilities operated by U.S. and overseas carriers meet. The rate is the same whether a satellite or cable transmission path is used.) The total charge, including what the overseas carrier gets for its half-circuit, ranges from roughly \$10,000 to \$12,500 a month.

In 1975, the Communications Satellite Corp. (Comsat) unveiled a new service called “Digisat,” which consists of subdividable 50Kbps all-digital satellite circuits. The satellite agency proposed to lease these new facilities to the IRC's at rates way below what Comsat charges them for alternate voice/data facilities—allowing the carriers, in turn, to cut their rates to the end user.

For some time, the carriers were reluctant to provide Digisat service—partly because they feared a loss of revenue,

RATES PROPOSED BY U.S. AND OVERSEAS CARRIERS FOR IDPLS SERVICE

Service Type	U.S. monthly half-circuit charge (1)			Overseas monthly half-circuit charge (2)				Total (end-end) charge				Difference between Present and Proposed Rates, End-End (5)			
	WUI	ITT	TRT	Germany	Belgium	France	Switzerland	Germany	Belgium	France	Switzerland	Germany	Belgium	France	Switzerland
AVD	\$4545.00			\$7735	\$6688	\$5307	\$7155	\$12280	\$11233	\$9852	\$11700				
Digital Private Line:	WUI	ITT	TRT(4)	Germany	Belgium	France	Switzerland	Germany	Belgium	France	Switzerland	Germany	Belgium	France	Switzerland
1200 bps.	\$2500	(3)	\$2300	\$4050	\$3895	\$3342	\$4293	\$6350	\$6195	\$5642	\$6593	48%	45%	43%	44%
2400 bps.	3000	2500	2500	4705	4545	3879	5008	7205	7045	6379	7508	41	37	35	36
4800 bps.	3900	3500	3300	5710	5504	4710	6054	9010	8804	8010	9354	27	22	19	20
7200 bps.	4500	(3)	3600	(3)	(3)	5473	7155	(3)	(3)	9073	10755	(3)	(3)	8	8
9600 bps.	(3)	4000	3900	7500	6385	6191	(3)	11400	10285	10091	(3)	7	8	-2	(3)

1. Amounts shown are present AVD and proposed digital private line service half-circuit charges from the East Coast of the U.S.

2. All amounts shown in this column are approximate overseas half-circuit rates expressed in U.S. dollars, and are based on current exchange rates.

3. No rate proposed for service at this speed.

4. Rates shown for TRT include a charge for an "analog/digital adapter" (modem) needed to

interface an analog subscriber's access circuit. Those subscribers using digital access would pay the following rates: \$2155 (1200 bps.); \$2350 (2400 bps.); \$3040 (4800 bps.); \$3275 (7200 bps.); and \$3515 (9600 bps.).

5. Based on the lowest of the proposed U.S. half-circuit rates. The percentage shown is derived from the following formula: $\frac{\text{present} - \text{proposed rate}}{\text{present rate}}$

partly because the overseas carriers didn't appear to be interested (January, p. 183). But those problems now appear to be largely resolved. Within the past few months, Germany, Belgium, France, and Switzerland have all agreed to offer digital private line service at specified rates, and three U.S. IRC's—Western Union International (WUI), ITT, and TRT—have announced their proposed charges.

Before the service can be offered, the FCC must authorize it—by approving applications the IRC's have already filed—and by allowing the proposed rates to become effective. A commission source says the authorizations (usually called "214 applications") likely will be acted on early this month. The FCC has been pushing the international carriers hard to

It isn't totally clear what the IRCs will pay Comsat for satellite half-circuits.

offer reduced-rate digital data service—threatening at one point to let Comsat deal directly with end users if the IRC's didn't take steps to implement the satellite agency's Digisat offering—so the commission probably will accept their requests for operating authority. Once the 214 applications are out of the way, it's likely to take about another month to act on the tariffs.

Rates proposed by both the U.S. and overseas carriers for what is now generally referred to as "international digital private line service" (IDPLS) are listed in the accompanying table.

While IDPLS is far cheaper than AVD, it is limited to data communications. Separate circuit facilities would be needed for any voice messages a user is now sending

or receiving over his AVD circuit. Because of the savings generated by the new rates, a user who didn't make a lot of overseas telephone calls probably could transfer them to AT&T's international dial-up network and still save money by using IDPLS.

Another factor is that AVD is an analog service. IDPLS, being digital, is inherently less prone to errors and probably will produce higher throughput than an AVD circuit operating at an equivalent bit rate.

Since 1975, when Comsat unveiled Digisat, the satellite agency and the carriers have been arguing about whether the new service should include cable as well as satellite transmission. Also, it still isn't totally clear what the IRC's will pay Comsat for satellite half-circuits.

Earlier this year, Comsat and the FCC negotiated settlement of a long-standing rate dispute which resulted in a filing, by the satellite agency, of lower tariffs for all of its services. The FCC has told the U.S. international carriers they can lease satellite circuits at the lower rates only if the savings are totally "flowed through" to the end users. There is some reluctance on the part of the carriers to do this.

The IDPLS charges proposed by TRT, and possibly those filed by the other IRC's, are based on the lowered Comsat rate for a 50Kbps half-circuit—even though none of the carriers has yet agreed to 100% flow-through. But, according to Richard Yalen, TRT's tariff chief, even if his company has to pay Comsat the "old" rate for a 50Kbps half-circuit, the charges to end users probably won't be increased beyond what has been proposed. Basically, this is because the difference between the two Comsat rates, on a per-circuit basis, is "nominal," says Yalen, given the number of IDPLS circuits TRT expects to lease. (The company has already won a contract to supply the Department of Defense with three IDPLS circuits to Germany. Two more leases are

projected by the end of the first year the new service is in operation, three more in the second year, and six more in the third year.)

The other unresolved question—whether IDPLS should be a satellite-only or a composite cable and satellite service—is also likely to be settled without too much trouble.

Comsat has objected strenuously to a composite service. The agency alleges this arrangement would cost the end user far more than one based on exclusive use of satellite facilities. Also, Comsat argues that the satellite-only version was what the FCC ordered the IRC's to provide in a ruling issued early last year.

However, Comsat's real motivation may be less altruistic than these comments suggest.

Comsat has objected strenuously to a composite service of cable and satellites.

Last October, it said the FCC should let Comsat offer Digisat directly to end users unless the IRC's agree to offer a digital private line service exclusively via satellite. It was one of several moves by Comsat, before and since, aimed at repealing the FCC's 1966 "authorized user" decision and enabling the satellite agency to get into the end user market.

In any event, the question of whether satellite-only service would be cheaper than a composite offering may be academic. The tariffs proposed by the IRC's so far, all of which are based on a composite transmission path, promise the user a significant saving—and that probably will be the decisive factor as far as the FCC is concerned.

-P.H.

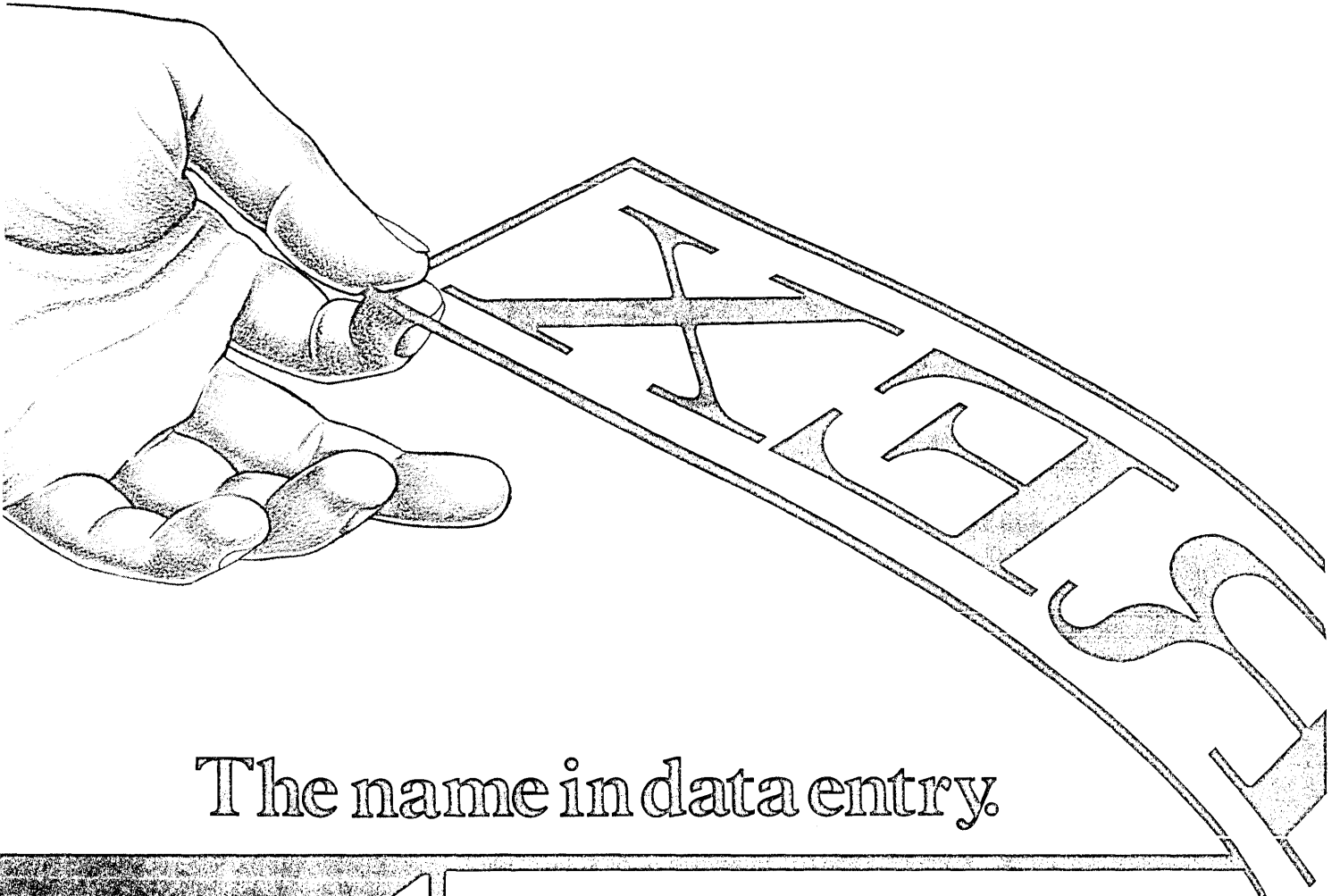

The name in data entry.

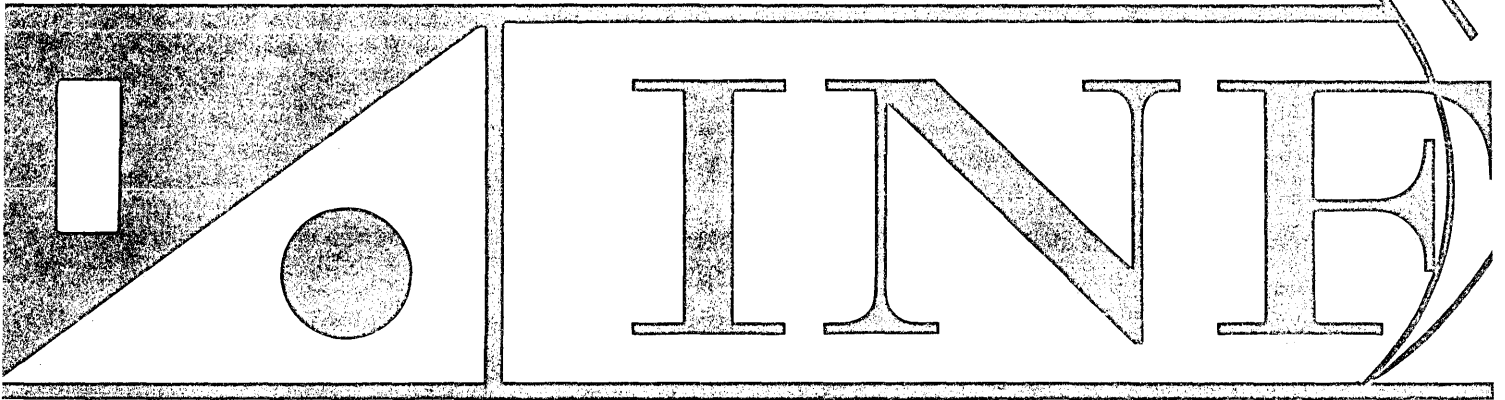

The name in intelligent terminal systems.

You've known us for years as the name in data entry. Since 80% of distributed data processing is data entry oriented, Inforex has a strong edge when it comes to designing and supporting an intelligent terminal system.

The Inforex System 7000.

It features interactive COBOL, virtual memory, concurrency, and interactive debugging. Cluster or stand-alone terminals, large local data storage.

A few innovations that

are making us the name in intelligent terminal systems for distributed data processing.

Plus a support team rated number one by DEMA*.

Look closer, the name is INFOREX.

*Data Entry Management Association survey available on request.

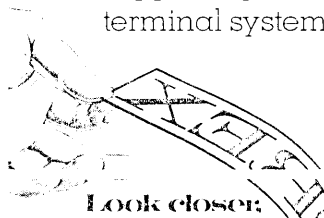

Look closer:

Distributed data processing, data entry, and information management worldwide.



there is no alternative.

21 North Ave., Burlington, MA 01803 Dept. B9 (617) 272-6470

CIRCLE 116 ON READER CARD

IN COURT WITH DEC

Tiny Computer Operations' four-year battle with DEC in court.

Stephen Silverman admits to feeling much like the Biblical David who took on the Philistine giant Goliath. And, as in the Biblical story, Silverman's Goliath, Digital Equipment Corp., is counting on being impervious to the slingshot, legal assault mounted by the 36-year-old Computer Operations Inc. president.

The small Lanham, Md., peripheral company brought an unexpected lawsuit against the mighty minicomputer maker four years ago, charging that DEC's 1968 patent on its DECTape system (used on the PDP-8 and PDP-11 minis) was invalid since it was fraudulently obtained.

That's the crux of the case, but there's a lot more to it than that, says Silverman, who feels DEC doesn't realize that, as a result of these patent fraud allegations, its ethical reputation could be on the line. "It's clear," he maintains, "that DEC doesn't take this whole thing very seriously."

A lawyer for DEC denies this, saying, "DEC has always taken it seriously. Up until now," he declares, "the war has not escalated. It's been treated on its merits."

COI, a 10-year-old company that had supplied peripheral-to-minicomputer interfaces and was also into the small systems market, switched its focus eight years ago to LINC tape products which used basically the same format as the original LINC tape drive that was developed in 1962 at MIT's Lincoln Laboratories for use on its LINC computer. (The basic difference between the two tape systems is that while the LINC tape device searches bidirectionally, reading and writing in one direction, the DECTape unit reads and writes bidirectionally.)

Wanting to expand its market, COI a few years later began looking for ways to offer a plug-compatible PDP-8 and PDP-11 DECTape system. In the late '60s, when it was just starting up, COI had opted against entering this market for fear of the legal expenses of a potential patent infringement battle with DEC.

But by 1973, after endless hours and years of pouring over the DECTape patent, Silverman decided to take a shot at the DECTape market. At this point, he didn't consider this a rash move because he was following the go-ahead of his patent counsel who claimed the patent was invalid on several grounds. So in April 1973, COI plunged head-first into the DECTape business, offering a system



STEPHEN SILVERMAN—It's much like David vs. Goliath.

which it dubbed DECTape compatible, and which in reality was indeed DECTape.

Eight months after COI began its DECTape drive, DEC reacted with a letter to the company which stated that DEC believed COI was infringing on its patent, and if it was it had better stop. And this is where the battle began.

Lawsuit centers around legality of a DEC patent.

Undaunted, COI sent DEC back a letter, claiming the DECTape patent was invalid because the company in applying for the patent had not complied with patent law. What COI charged was that DEC had not disclosed prior technology, namely the Lincoln Labs' development work on the very similar LINC tape system which is in the public domain since it was government-funded.

DEC didn't buy COI's arguments and in another letter to COI, insisted that if the company didn't have better reasons it should halt its DECTape operation. Instead, COI filed its suit in the U.S. District Court in Brooklyn in the summer of 1974. The suit asks for the court to declare the DECTape patent invalid and seeks damages (antitrust) resulting from DEC's assertion of the patent against COI.

DEC countersued for patent infringement. Both suits were combined, and subsequently shifted to the U.S. District Court in Boston.

During discovery in the case, Silverman claims COI's legal team turned up "more and more frauds" related to the

DECTape patent. "We didn't know what a good case we had," he marvels. And that good case, he contends, hinges on the fact that allegedly DEC "not only offered DECTape systems (then called Microtape) for sale and took orders, but actually delivered the product more than a year prior to its patent application" in violation of patent law. "Just that alone," he contends, "would hang them." (Patent law requires that a patent be applied for within a year after a product goes on sale.)

DEC vehemently disputes this charge, and to defend itself in the case returned to the Patent & Trademark Office in February 1975 to apply for a reissue of the DECTape patent. According to one DEC counsel, the company willingly invited COI's participation in the reissue which at the time it felt was a sure thing.

Both firms funneled numerous documents into the PTO and COI, the ostensible beneficiary of this effort, was allowed by the office in an unusual move to be a party to the reissue action. COI in December 1975 filed a petition to "strike" DEC's patent reissue application. And after almost a year of deliberating the PTO, in November 1976, asked DEC to "show cause" why COI's strike petition should not be granted.

After requesting several extensions, DEC finally responded. But its response was not good enough for the PTO which last April granted COI's strike petition on the patent reissue, citing a surprised DEC with nine counts of fraud—eight of which are spelled out in the pending COI suit.

COI was understandably pleased with the ruling in which the patent commissioner found "clear and convincing" evi-

For the most air cargo service coast to coast...



Think Big.

The most markets.

When it comes to cargo, no one comes close to United. We fly direct to 109 cities, from Honolulu to New York. And reach 3,800 surrounding communities with fast 'n easy door-to-door delivery. United also provides convenient overseas connections with every domestic and international airline serving the U.S.

The most flights.

We offer you more planes too—362 jets, making over 1,400 flights a day. And every one carries

freight. Including 55 widebodies and 14 all-cargo DC-8F's. So your shipment has plenty of room to fly.

The most people.

United has over 2,000 people ready to help you full-time with your cargo needs. They'll give you consistent cutoff and recovery times. And with A.F.I.S., our advanced computerized tracking system, you'll be in complete control every step of the way. So next time you ship, trust your shipment to the biggest friend around. United.

UNITED AIRLINES CARGO

Think United.

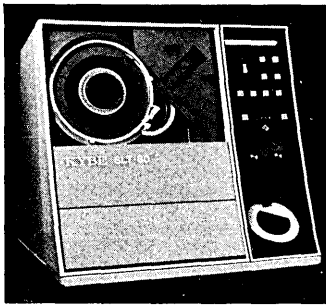

All major mainframe manufacturers use Kybe tape cleaners and testers.

The reason is simple. Kybe cleaners and testers have set the industry standards for years. They're first with the highest throughput speeds. First with the most effective cleaning and testing techniques. First in precision retensioning and restacking. And first in ease of operation. That's why all major mainframe manufacturers use Kybe equipment. It's also why more tape manufacturers and more tape libraries install Kybe equipment than all others combined.

Find out for yourself. The best equipment, competitively priced... from Kybe. Write for complete details.



KYBE CORPORATION
132 Calvary Street, Waltham, Mass. 02154
Tel. (617) 899-0012; Telex 94-0179
Sales Offices
Boston — (617) 899-0012 Los Angeles — (213) 980-8365
Chicago — (312) 644-5650 New York — (212) 594-9272
Houston — (713) 524-3111 Wash., D.C. — (703) 527-2292

CIRCLE 185 ON READER CARD

Litton Computer Services gives you

CLOUT

when you need it!

Litton packs a powerful punch with IBM 370/168 systems on line and ready to go to work for you ...

... wherever you are
... whenever you need it.

Put all the muscle and clout of five million bytes of non-paging memory in your corner. Big batch jobs? Tight turnaround? When you need more machine time and you need it NOW, look to Litton. We're ready when you are.

Find out how Litton can help you evaluate your individual computing requirements. Ask to see our "Evaluation Guide."

Call or write today:

 **Litton Computer Services**

1831 Michael Faraday Dr., Reston, Virginia 22090 • (703) 471-9200

CIRCLE 186 ON READER CARD

NEWS IN PERSPECTIVE

dence that DEC had committed these alleged frauds in its original DECTape patent application. COI president Silverman feels the PTO decision will help vindicate his company's suit.

A chagrined DEC, on the other hand, has set out to short-circuit the potentially damaging decision. In mid-July, the company filed a civil action in the Boston court against the patent commissioner, maintaining that he erred in his ruling. This suit could be combined with the original COI vs. DEC suit.

Meanwhile, COI hasn't rested on its victory laurels either. In May it submitted a motion for a summary judgment in the Boston court, asking for attorneys' fees (which are more than \$200,000 to date)

Patents office cited DEC with nine counts of fraud, but DEC has challenged the ruling.

and a date to be set for the antitrust trial to determine damages. The company previously had been turned down by the New York court on its first petition for a summary judgment, but hopes to be more successful this go-round in light of the PTO finding.

In preparation for its antitrust moves, COI has brought on board a special antitrust lawyer to help it evaluate the damages it claims are due. Although the company leaves these damages unspecified in its suit, it feels that if the court rules in its favor on the DECTape patent's invalidity, then in the subsequent antitrust suit it could be awarded damages on the basis that it was deprived of a certain percentage of the DECTape market had it started marketing the product on a certain date. Similar suits have resulted in treble damage awards of over \$10 million.

The little company also takes comfort in the fact that the Justice Dept.'s Antitrust Div. is routinely investigating the matter, deciding whether it also should hit DEC with an antitrust action. More fallout from the situation could result if the PTO's solicitor general decides to prohibit one of DEC's attorneys involved in the original patent application from practicing before the PTO commission for one year. The PTO ruling, to various degrees, implicated DEC parties to the patent application (including company president Kenneth Olsen) in the alleged patent fraud.

One DEC attorney close to the case insists the company is "very ethical" and has been totally honest in its dealings with the Patent Office. The important thing to remember, he says, is that there has "certainly been no intent to deceive" on DEC's part.

He also says that DEC's patent applica-

tion for DECTape did mention and describe LINC tape, although "not by name nor in any great detail." On the key issue of whether the company sold the system within the one-year time limit, he maintains that an experimental "breadboard" version was indeed delivered to a customer (Kie Corp., predecessor of Keydata Corp.) in the fall of 1963 but it was not operational, he argues, until January of 1964.

DEC filed for its patent in November 1964. So if this argument stands up in court, which DEC is sure it will, then the one year restriction would have been met. COI on the other hand claims to have proof (from DEC's very own documents) that the mini maker accepted purchase

Final step is for the court to determine whether the DECTape patent is valid and was infringed by COI.

orders and quoted delivery dates in the summer of 1963 for Microtape, since known as DECTape.

The central issue in this whole legal morass over DECTape is whether in fact the patent is fraudulent. If the court agrees with the PTO that it is, then it must also decide whether COI was hurt and whether the alleged fraudulently procured patent was "a material" cause of that damage.

If the court disagrees, the whole case is washed up as far as the antitrust aspects are concerned. The final step then will be for the court to determine whether the DECTape patent is valid and was infringed by COI. If it is valid, DEC would pocket damages from COI. If not, DEC would have to ante up damages for COI.

Whichever way it goes, there definitely will be an appeal which could go as high as the Supreme Court. DEC is hoping the messy suit can be resolved in the next one to two years. Committed to seeing the thing through to the end, the company is, and always has been, set against any settlement with COI—even though COI has repeatedly sought to recoup its mounting legal fees, legal fees which COI, with \$1.4 million in annual revenues, can ill afford.

COI confirms it made several offers to DEC, prior to the PTO ruling, to drop the suit if DEC would agree to pay its attorneys' fees and let it market its DECTape products without a royalty restraint. COI's Silverman claims the company's efforts "were rebuffed every time."

DEC is reported to have viewed some of these "conciliatory" attempts as "scare tactics," and would have nothing to do with COI. And it's sure, of course, that it is and has been right all along. DEC presi-

NCE

100% EQUITY

**•LEASE •RENT
•PURCHASE**
**NOW! Full
Ownership
After 24 mos.**

**\$139.mo.
or
\$2695.**

Call or write
for more
information...

NCE NCE TERMINALS & COMMUNICATIONS, INC.

<p>Regional Office East 300 Raratin Ctr. Pkwy. Bldg. 806, Edison, NJ 201-225-0892 Toll free # 800-631-5919</p>	<p>Headquarters Office Midwest 945 W. Liberty Dr. Wheaton, Ill. 60187 312-682-0001 Toll free # 800-323-1780</p>	<p>Regional Office South 1110 Busch Blvd. Tampa, FL 813-932-2666</p>
---	--	---

CIRCLE 190 ON READER CARD

DECWRITER:

LA 36\$1495 or \$76 mo.
LS 120 2895 or 148 mo.
LA 180 2450 or 148 mo.

VT 52 1550 or 79 mo.
ADM 3A 850 or 44 mo.

DIABLO:

1620-1 2695 or 139 mo.
1641-1 " "
1660-1 " "

REGENT 100 1325 or 60 mo.

TERMICETTE 3321 . 1895 or 87 mo.

ACOUSTIC COUPLER 245 or 13 mo.

WORK STATION ... 295 or 13 mo.

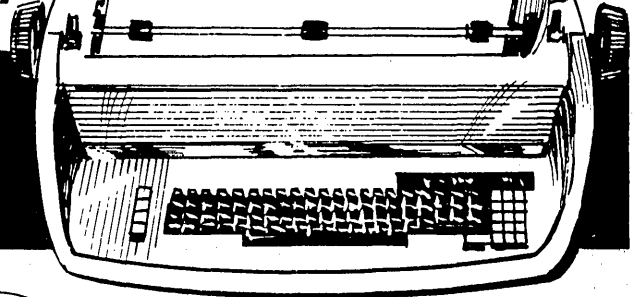

**Turnkey factory data
collection
systems**



When Sierra installs a System 7000 in your plant, it's ready to go to work for you.

The 7000 System includes: Complete hardware interface to your computer. Complete software with customized application programming. Complete phase-in program to assure correct employee reporting. Complete service and maintenance support.

You get complete Shop Floor Control in real time: Labor reporting • Attendance and overtime reporting • Order entry • Purchasing/receiving • Stores control • Shop order release • Machine maintenance reporting • Material tracking • Quality status.

Send for complete information or phone 716/631-6401.

SIERRA DATA SYSTEMS

Division of Sierra Research Corporation
247 Cayuga Road, P.O. Box 222, Buffalo, New York 14225

CIRCLE 192 ON READER CARD

DISTRIBUTED PROCESSING: ONLY DIGITAL CAN MATCH YOUR MIX. AND NETWORK IT.

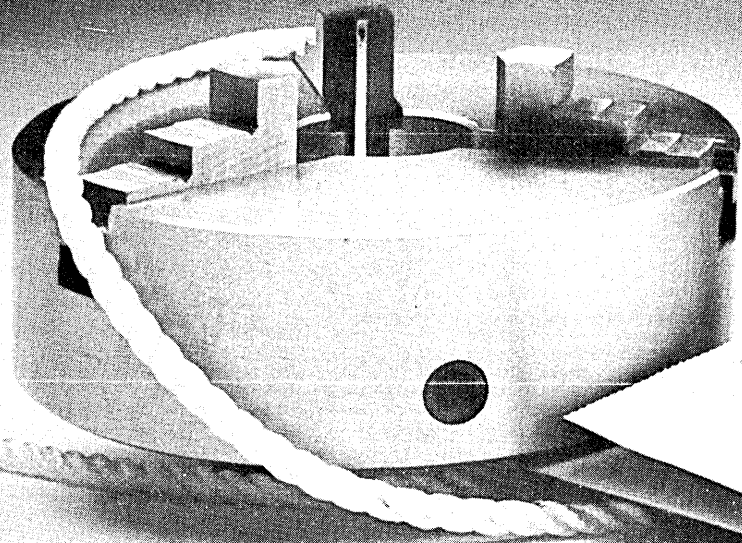

1. THE 80/20 REALITY.

If you remember nothing else from this ad, remember this: Networked computers do 80% of their work for local users. (After all, that's the whole purpose of distributed processing.)

2. THE SIGNIFICANT POINT.

It follows that the efficiency of any network is 80% a function of how well local computers do local jobs. And this leads to the significant point about DECnet, the only second generation networking software in the industry. Only with DECnet and Digital computers can you build a network that's optimized at every node.

3. EFFICIENCY AT THE LOCAL LEVEL IS NO MEAN TRICK.

Every company has a great variety of different jobs that computers must do, but no two jobs are exactly the same. You need one kind of system for

interactive applications like order entry. A completely different kind of system for real-time applications like running a lathe. It has to follow that no computer company can even begin to talk about "optimizing your network" unless it can give you a choice of computer systems as varied as your list of tasks.

4. NOW, TWO CRITICAL QUESTIONS.

Ask your computer company two things: "Can you provide a complete range of systems in all the essential computer categories? Can you network those computers together without regard to word length, operating system or language?"

5. ONLY DIGITAL ANSWERS "YES" TO BOTH QUESTIONS.

Digital built a billion-dollar business by making specific products for customers with specific needs. Today Digital is

the only computer company that builds all four essential categories of computer systems, and it's the only company that allows you to join these systems in a network where every node matches the local application in functionality and price/performance.

6. ONLY DIGITAL CAN NETWORK ALL THESE DIFFERENT SYSTEMS TOGETHER.

Small real-time systems in 12- and 16-bit architectures with a wide range of operating software to monitor and control on-going events. Many of these systems have been optimized for specific applications including interactive graphics, production control, laboratory analysis, and data collection and processing.

Massive real-time computational systems like 32-bit VAX-11/780 can be configured to handle everything from complex scientific, engineering and

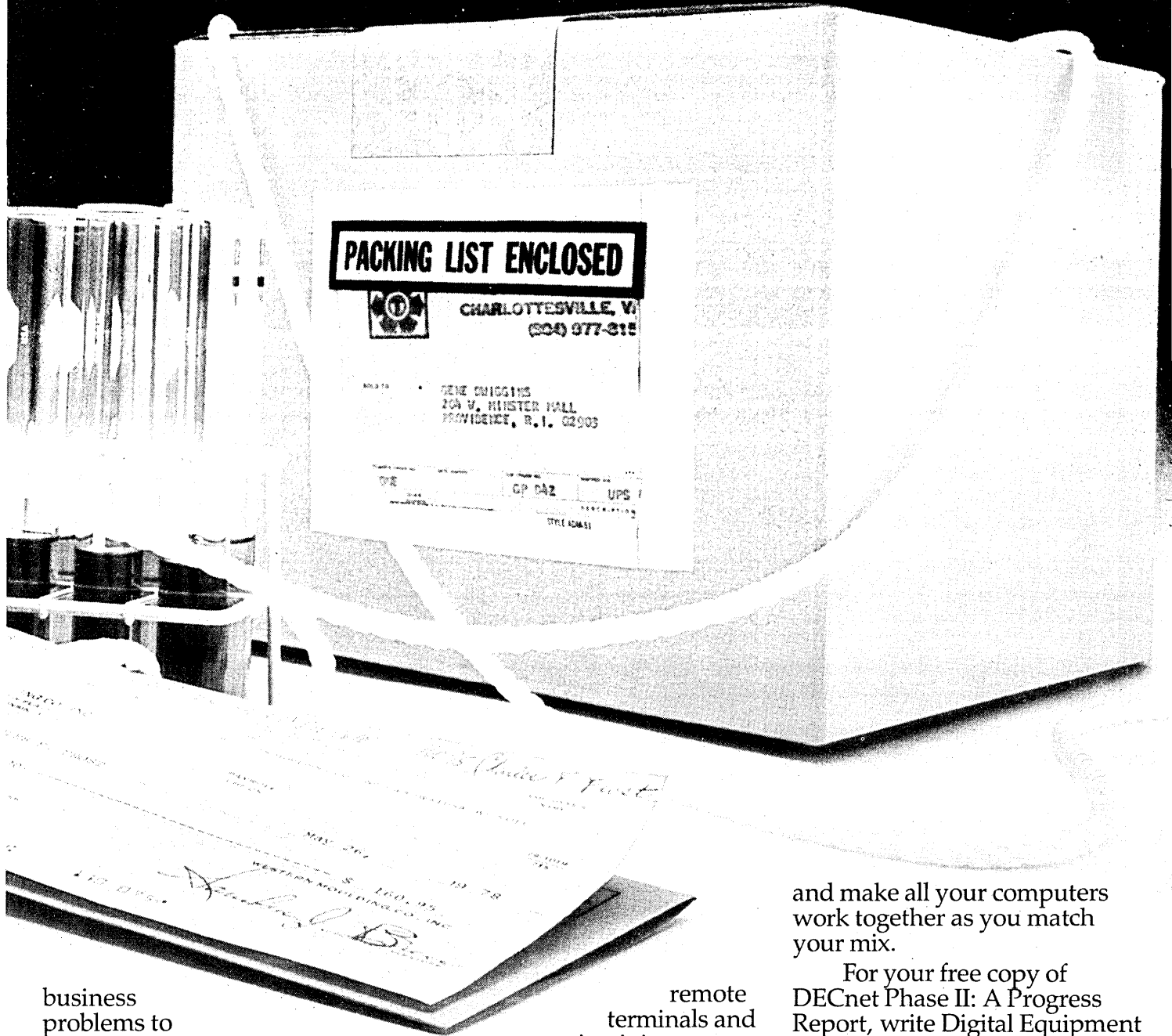

business problems to simulation, large-program runs, and other applications requiring high input-output traffic in multi-user environments.

Small timesharing systems designed for the office, warehouse or laboratory with a wide choice of architectures and operating systems tailorable to many different multi-user and multi-task applications.

Interactive mainframe systems. 36-bit DECsystem 20's provide the power and flexibility to handle a wide range of business applications and scientific tasks for a number of interactive and batch users simultaneously while supporting a large number of

remote terminals and maintaining massive on-line data bases.

7. DECNET PUTS IT ALL TOGETHER.

DECnet, Digital's comprehensive networking software, supports general interconnectability of this complete range of distributed computer systems so you can exchange files, share data bases and other resources,

and make all your computers work together as you match your mix.

For your free copy of DECnet Phase II: A Progress Report, write Digital Equipment Corporation, 146 Main Street, Maynard, MA 01754. Attn: Communication Services (NR-2/2). European headquarters: 12, av. des Morgines, 1213 Petit-Lancy/Geneva. In Canada: Digital Equipment of Canada, Ltd.

digital

Please tell me more about how DECnet and Digital computers make the best and least expensive distributed networks in the world.

Name _____ Title _____

Company _____

City _____ State _____ Zip _____

Mail to: Digital Equipment Corporation, 146 Main St., Maynard, MA 01754.
Attn: Communication Services (NR-2/2)

NEWS IN PERSPECTIVE

dent Olsen's stand on the suit also reflects this attitude. In a recent meeting to rally his legal troops he urged them to "press on."

The current animosity between the warring companies is such that no reconciliation overture on either's part is likely. COI clearly won't back down even though, as Silverman laments, "the growth of this company has been inhibited by this lawsuit."

DEC seems fully aware of COI's position and is puzzled about what the tiny company thinks it stands to gain in the long-run. This is especially true since it consid-

ers the product a has-been supplanted by floppy disk technology. But like COI, DEC is not about to throw in the towel.

Says the DEC lawyer: "COI has rolled the dice. It has started a game and now it can't stop because it has too much invested." And that investment will mount on both sides as the litigative maneuvering continues, because as one observer points out, such court battles can be long, drawn-out processes. "It's a long day at the races," he reflects, "and the horses are still running."

—Linda Flato

PEOPLE

EMPHASIS ON SOFT

Dr. Robert Spinrad takes over Xerox's Palo Alto Research Center.

"The big question in computers today is what to do with them," said Dr. Robert Spinrad.

Spinrad believes we're at the start of an information handling revolution and he likes the charter given Xerox's Palo Alto Research Center (PARC) by board chairman C. Peter McColough to help Xerox "become the architect of information."

Spinrad moved to Palo Alto last month to become vice president of research and manager of PARC. He left a position as

In 1968, after being courted for years, he joined Palevsky at SDS.

vice president of the Systems Development Div. of Xerox Business Systems in El Segundo, Calif. At PARC he succeeded Dr. George Pake, director of the center since its founding in 1970, now head of all research for Xerox Corp.

Spinrad is concerned today with chips and the lowering costs of logic. He also is concerned with software which is a major emphasis at PARC. But early on he was involved with big machines. Even then, he thought software was "the gutsy problem."

A native of New York City, Spinrad did his undergraduate work at Columbia Univ. where he took what may well have been one of the first computer sciences courses in 1953. "We worked with a big computer at NYU," he recalled, "with big steel tapes."

From Columbia, Spinrad went to work for Brookhaven National Laboratory as a researcher in physical sciences. He was reintroduced to computers. "In 1956, I was asked to copy the MANIAC computer at Los Alamos. It was a wondrous old engine."

But Spinrad still was more a physicist than a computer scientist. In '59, having received a masters from Columbia, he went back to get his doctorate at MIT. There he became involved with small computers of the PDP-1 class.

In '62, he returned to Brookhaven and put much of its research on-line to small computers, "a first," he said. In the same year, he purchased the second Scientific Data Systems computer ever built. "The first had not yet been delivered." He was consulting for Bell Labs at the time, "with Brookhaven's blessing." He saw a

MINICOMPUTERS

MARKET FOR 32-BITS

SEL scores a coup in hiring away two principal members of DEC's team.

The 32-bit minicomputer market is rapidly emerging as one of the more hotly contested battlegrounds in the dp industry with two vendors squaring off as the prime competitors, at least for the time being: Systems Engineering Labs and Digital Equipment Corp.

The most recent salvo in this confrontation was fired by the Ft. Lauderdale, Fla. based SEL which scored a coup in hiring away two principal members of DEC's 32-bit hardware and software team.

Joining SEL, which has been in the 32-bit market since 1969, were Roger Gourd,

expect to be a \$100 million company in two years."

In going after Gourd and Hughes, SEL may be reacting to inroads DEC reportedly has been making in the 32-bit arena. Prior to the VAX introduction, that arena had been dominated by SEL and Interdata.

An industry analyst close to DEC notes that VAX "is really scoring." Thus far, the VAX orders have been restricted to one or two machines per customer but the potential for large volume orders is there, he asserts.

Moreover, DEC's admitted problems with the VAX software—problems SEL has underscored in selling its own machines—haven't really hurt DEC's sales since at the outset the computer giant is selling primarily to large sophisticated users who can provide their own software.

Fueling the growth of the 32-bit market is the fact that costs for the components which go into manufacturing 32-bit systems have dropped to the point where the cost differential of producing a 16-bit and 32-bit machine is rapidly closing.

And with the advantage of its larger address field and richer instruction set, the 32-bit technology represents an attractive architecture for anyone off-loading an IBM 370 and moving to a decentralized environment, Frick observes.

SEL itself is expanding from its traditional vertical markets, such as simulation, engineering monitoring and laboratory processing, and is making a run at the manufacturing sector. Additionally, it recently introduced several machines aimed at the lower end of the 32-bit market, including the SEL 32/5720 which sells for about \$40,000.

Now if Interdata, which is retrenching, gets back on its feet and Hewlett-Packard, which is rumored to be coming out with a 32-bit machine, enters the fray, the 32-bit arena could really explode.

—Laton McCartney

Costs for the components used in manufacturing 32-bit systems have dropped close to the 16-bit price.

who was involved in the software design of DEC's VAX-11/780 machine. Gourd assumes the position of director of software engineering.

Additionally, Leonard Hughes, who had served as manager of the VAX hardware group, came over to SEL last month where he'll function as director of hardware development.

Says SEL vice president of marketing and sales, Philip W. Frick, of the new hiring: "We wanted a compatible team because it's difficult to isolate hardware and software. Gourd and Hughes bring to us their ability to manage the development of large systems and we need that kind of expertise, particularly since we



ROBERT SPINRAD—Computers—what to do with them?

spec sheet for the SDS 910. "I was impressed and I called them. They said they'd send somebody to talk to me. The guy they sent knew everything I wanted to know about the machine. That was the first time I met Max Palevsky."

He was asked to join Palevsky's SDS over a period of years and did serve the firm as a consultant, again "with Brookhaven's blessing." It wasn't until 1968 that he finally succumbed and went to SDS full time as vice president for programming.

Spinrad has other distinctions. He was the conference chairman for what now has become fondly dubbed "the last of the fall joints"—the Fall Joint Computer Conference in Anaheim in 1972. "It's something everyone should do once," he said. He wouldn't do it again and has had no involvement with the successor to the semiannual Spring and Fall Joint Computer Conferences, the annual National Computer Conference.

But he is involved with the Univ. of California Engineering Advisory Council, the International Institute of Applied Systems Analysis, and the visiting committees for computer sciences at Stanford Univ. and math for MIT.

Of his work for the Fall Joint Computer Conference, he says, "it was a very real, worthwhile thing to do." He said it took two hours per week of his time at the beginning but, at the end, the last two months, it took up half his time.

Of his latest job switch, he says it's a return to what he likes best—research. And he hopes to do something about what he considers the "dominant problem in computing today—programming."

—Edith Myers

Our main point is not losing your point



with TRAVERSCAN Absolute Free-Cursor Digitizer

the cursor may be lifted from the digitizing surface without losing the point of origin *but there's a lot more!*

It's what we can do with all your other points . . . which we measure, count, display and record with sign and 6 digits per axis, in linear or square inches, feet, yards, miles, millimeters, centimeters, decimeters, kilometers, acres, hectares or square kilometers.

And how about our other points? We provide a Resolution of .001" (.025mm) a Repeatability of $\pm .001$ " (.025mm) and an Accuracy of $\pm .005$ " (.127mm) over the entire 42" X 60" digitizing surface . . . at a cursor movement rate of up to 60 inches per second.

You also get presettable axis coordinates, Independent Axis Variable Electronic Scaling in English or metric; digital planimeter for automatic area computation, standard output interfaces for card punch, paper

tape, cassette, mag tape and mini-computers. Electronics stored in height adjustable table which also tilts from 0° to 80°. There are options galore including numeric and alphanumeric keyboards . . . and programmable keys on the cursor.

We've made our point . . . but there's more to tell.

Send for brochure or give us a call.
Keuffel & Esser Company
H. Dell Foster Operations
P.O. Box 32581
San Antonio, TX 78216
(512) 494-5511

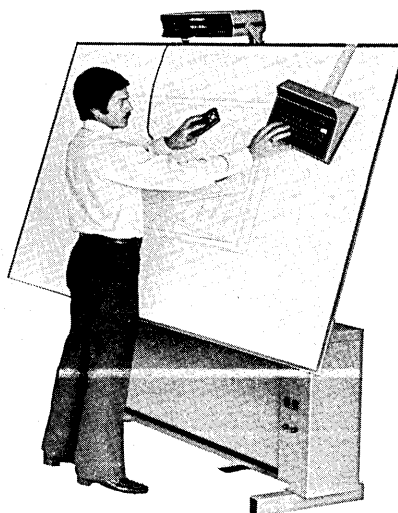

KEUFFEL & ESSER COMPANY

H. Dell Foster Operations

DP IN ISRAEL

Huge conference draws 400 professionals from overseas.

Ever since Israel started a computer industry in the 1950s, it has leaned heavily on outsiders for technical support. This was very much in evidence last month during the U. S.-sponsored Third Jerusalem Conference on Information Tech-

nology (JCIT 3) when about 400 computer professionals from overseas were as much of an attraction as the technical sessions.

But about 2,400 Israeli computer people also attended, an unusually high number because the country's complement of dp professionals totals only about 4,000. Conference chairman, Anthony Ralston, a former president of the American Federation of Information Processing Societies, said that if the same percentage of U. S. computer people came to the National Computer Conference, the attendance would be some-

thing like 125,000. (The NCC turnout last June in Anaheim, Calif., was 57,000).

Support from overseas computer professionals for the Israeli dp effort was in evidence at the Jerusalem conference in the form of innumerable corridor discussions between the natives and the visitors. But these discussions reflected only one small part of a unique system Israel has designed for exploiting the expertise of its friends overseas.

In 1967, Prime Minister Levi Eshkol proposed establishment of international committees to advise each of Israel's major industries. The following year, several committees were established, including two for the Israeli computer industry: one is composed of U. K. and Western European computer professionals, the other is drawn largely from the United States (the balance comes from Canada).

This terminal is fast, bilingual, and can chart a course.

The AJ 860. Quite probably the most highly featured desktop teleprinter terminal you can buy. And now you can buy a lot more including 1200 baud, APL, and graphics.

In full duplex mode, you can operate at any speed from 110 to 1200 baud. In half duplex mode, you can operate at up to 450 baud.

APL capability. Now you can have a full APL code set including overstrike characters. And exceptional print quality from our 9 x 12 dot matrix character cell which produces high resolution 9 x 5 characters. You can switch from APL to the standard ASCII set either from the keyboard or by remote control.

Graphic printouts. Now you can have a graphics character set that prints bar graphs, flow charts, block diagrams and other illustrations.

This is all in addition to the long list of standard features that have made the AJ 860 so popular: 128-character ASCII code set, dual gate forms tractor, easy-to-use

sculptured keyboard, 17-key numeric pad, complete forms control, RS 232 line interface, mobility, and more.

Get full details on the AJ 860. Call your nearest AJ sales office. Or write Anderson Jacobson, Inc., 521 Charcot Avenue, San Jose, California 95131, (408) 263-8520.

In Europe: Anderson Jacobson S.A., 14 rue Leon Gambetta, 92120 Montrouge, France, telephone 654 10 10; Anderson Jacobson Ltd., Shepperton, Middlesex, U.K., TW178AP, telephone Walton-on-Thames 44439



The AJ 860. It's got it all.

 **ANDERSON JACOBSON**



WERNER FRANK—heads U. S. group assisting Israel's dp efforts.

The U. S. group—currently headed by Werner Frank, executive vice-president of Informatics—consists of about 100 of this country's top dp professionals. Although none of the committee members represents his employer, the list of affiliations is impressive. It includes most of the leading teaching institutions in the United States, as well as the major mainframe, software, and service suppliers. All committee members give their time and advice at no charge.

Since it was established in 1968, the U. S. committee has provided a number of support services, formal and informal. For example, just before last month's JCIT began, Israeli dp users and suppliers needing help with systems or products spent an entire day consulting with members of the committee. According to one participant, if the advisors at that meeting had charged commercial rates, the bill would come to at least \$100K.

Recently, the U. S. committee helped Israel's biggest dp firm, Elbit Computers, set up a joint venture software company with Rand Information Systems, San Francisco. Previously, it opened doors for two other Israeli vendors—Sci-Tex and Elscint—who now are marketing their products in the United States. The committee has provided marketing and technical advice to several other Israeli dp firms as well, and thanks partly to a series of short courses brought to Israel several years ago by one member of the committee—Bernie Galler, professor of computer and communication sciences at the Univ. of Michigan (and former president of ACM)—the Israeli government was encouraged to establish a permanent education program for its computer professionals.

The U. S. committee also sponsors the

U.S. committee sponsors JCIT in collaboration with the U.K. group and another one composed of Israelis.

JCIT, in collaboration with the U. K. group and another one composed of Israelis. Although Americans were well represented on the steering committee for this year's meeting, most of the drive came from conference cochairman Dov Chevion, president of the Information Processing Assn. of Israel (IPA).

Chevion, who also directs a government computing center, is a walking encyclopedia of facts and figures about the Israeli computer industry. In the past five years, he reported, the number of installed systems has increased more than 50% (from 400 to "over 600"), the number of terminals has increased even more ("from 800 to more than 2,000"), and adp expenditures have grown from 1.2% to 2.6% of GNP. Although he admits the industry is still small in absolute terms, Chevion adds that "we rank higher in computing power per capita than half of the world's developed nations."

The main targets of this sales pitch are the hardware and software vendors in the U. S. and elsewhere. The government wants them to set up shop in Israel, preferably on a joint venture basis.

The importance of this "outside partnership" is suggested by a recent government study, which found that foreigners own, partly or completely, 22 of Israel's 28 largest data processing equipment firms. Because a significant share of the total revenue earned by Israeli dp vendors comes from exports—the percentage is more than 40% in several cases—the technology and technical expertise provided by overseas partners may be even more important than their capital contributions.

In exchange for this technical and financial support, U. S. firms which establish manufacturing/assembly facilities in Israel and then ship from there into the Common Market, avoid the 7% duty assessed on products exported directly from the U. S., explains Uzia Galil, president of Elbit Computers. "Also," adds Galil, "we are thoroughly acquainted with European marketing methods, so we can frequently provide valuable advice to our partners, particularly those who have not previously sold outside their own country."

Galil is intimately familiar with both

exports and partnerships. Elbit was established in 1967 as a joint venture between the Israeli government and private investors. Three years later, CDC acquired a 51% interest. The company manufactures a small business computer system called PACT, plus a line of IBM and Teletype-compatible terminals, which are marketed throughout the world. In 1977, 55% of Elbit's sales came from abroad.

One of the handouts at this year's JCIT was a 276-page report, issued by the Ministry of Industry, Commerce and Tourism, entitled "Thirty Years of Computing in Israel." Any U. S. company

IBM 360/370 USERS!

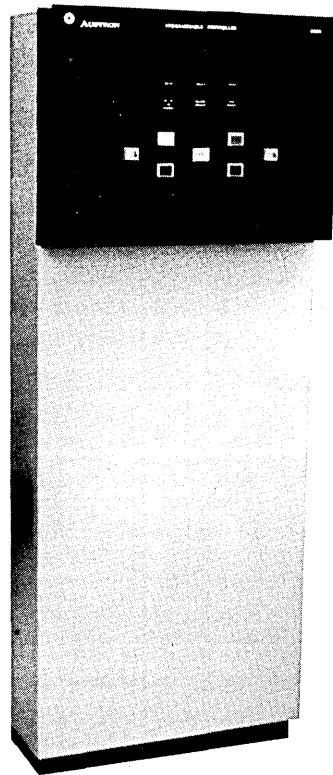

**interface your
minicomputer
to the IBM 360/370**

*without
software changes*

The Austron 8500 is a unique, programmable controller for the IBM 360/370 which lets you directly interface your minicomputer, terminal or other non-standard peripheral. All logic and problems associated with transferring data in and out of the IBM 360/370 are handled within the 8500.

- Allows interfacing directly to the Byte Mux, Block Mux, or Selector Channel
- General purpose, programmable processor with memory capacity up to 65K bytes
- Up to 4 interfaces with standard chassis (12 interfaces with expanded chassis)

SEND TODAY FOR DESCRIPTIVE LITERATURE

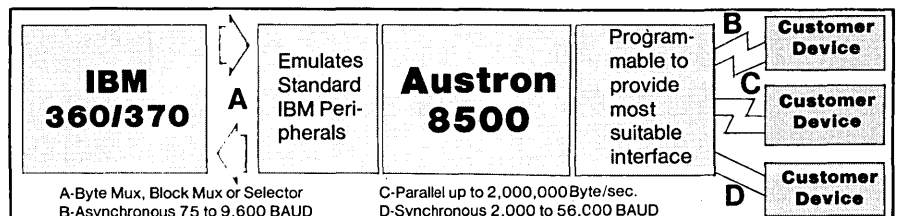

AUSTRON INC.
1915 Kramer Lane, Austin, TX 78758
Tel. (512) 836-3523

CIRCLE 170 ON READER CARD

NEWS IN PERSPECTIVE

that's interested in marketing abroad will almost certainly find its contents interesting.

The report contains detailed breakdowns showing the distribution of Israeli computer installations, by system size, among the country's major economic sectors, plus similar analyses of rental and maintenance costs, average operating hours a month, and projections of growth in the installed base. Supplementing this data is a lengthy survey showing who the users are in terms of number of employees, annual revenues, type of usage (service bureau versus in-house system), and several other characteristics.

There also is a detailed profile of each of Israel's major computer products vendors, and a chapter analyzing the educational attainments, professional training, and job responsibilities of Israeli programmers, systems analysts, and system managers. (One table, among many in this chapter, lists the average number of jobs which have been held by programmers, analysts, and managers, along with the average number of employers for whom members of each group have worked. The two figures are then compared to show the job-hopping and promotion patterns within each group.)

Unlike most publications of this type,



GEOGRGE GLASER—the whole issue is boring.

the Israeli report concedes that problems exist. For example, the chapter on manpower cites a number of deficiencies in the educational system for computer pro-

fessionals, and says improved procedures must be developed to overcome "a seemingly immature structure of management functioning."

It also calls for new incentives to encourage more women to become computer professionals (they comprise 33% of the overall Israeli workforce, but only about 16% of the professional computer community). The report includes a paper written by Werner Frank which proposes a basic restructuring of Israeli's software industry to counter "the lack of encouragement given by a less-than-enlightened user community."

Several interesting papers were presented at JCIT 3. Some summaries:

The byzantine struggle among U. S. financial institutions, consumer groups, and civil libertarians over EFT is likely to get worse, said George Glaser, president of Centigram Corp., Sunnyvale, Calif., a former president of AFIPS. "It's entirely possible that progress (in deploying EFT systems and networks) will be slowed dramatically if not crippled altogether" by the arguments currently raging in Congress over such questions as the need to share EFT terminals, promote competition among suppliers of EFT services, and protect users' privacy.

A further complication, is that the whole issue is "boring, if not incompre-

IMMEDIATE DELIVERY!!!

RSI CATALOG

MINI PACKAGE

- ▶ NOT A DIRECTORY ...
- ▶ A single source for more than 200 mini-packages in inventory.
- ▶ Most can be shipped to you in 20 to 48 hours.
- ▶ Descriptive Narratives ... Low prices (none higher than \$970) ...
- ▶ End User, Turnkey Supplier, Software Consultants ... A universal volume that will help you cut costs and increase profitability.
- ▶ DISTRIBUTOR INQUIRIES INVITED

ENCLOSED IS MY CHECK FOR \$29.95

(check must accompany order)

plus \$5 for postage and handling to:

RSI Inc. 140 Sylvan Ave.
Englewood Cliffs, N.J. 07632
201-947-6104

Name _____ Title _____
Company _____
Address _____ City _____
State _____ Zip _____ Phone _____

EXECUTIVES/PROFESSIONALS

LOANS BY MAIL UP TO \$5,000

Borrow \$100 to \$5,000 for any good reason: to pay off bills, fix up the house, take vacations, etc. No co-signers. No mortgages of any kind required. Absolute privacy. Fast service. No obligation—no agent will call on you. For complete details, write Dial Finance, Dept. 3724 340 S.W. 8th St., Des Moines, Iowa 50309.

Dial Finance 

Dial Finance, Dept. 3724
340 S.W. 8th St., Des Moines, Iowa 50309

Please rush me complete information concerning your Loans by Mail Program to \$5,000.

NAME _____
ADDRESS _____
CITY _____ STATE _____ ZIP _____

hensible to the public and to most legislators. The stage is set for two or three years of classical political struggle affecting . . . the entire financial industry. It will be fought by special interests and won by those best able to manipulate public opinion."

In a paper entitled "The Future of Computer Technology," I. M. Barron, of the United Kingdom, predicted that by 1980, an integrated circuit chip containing 100K transistors should be economically feasible (this would be about four times the maximum density of today's IC's). It will then be possible to accommodate "the majority of systems" on a single chip, Barron explained, and "further increases in the level of integration will do little" to reduce user costs.

Regarding software, "the use of computer aids may simplify the mechanical aspects of programming . . . but further reductions in the cost of developing software seem unlikely because the effect of the various computer aids is to make the design of software harder. What technological development will do is to reduce the need for a programmer to have specific expertise in computing . . . As a result, programming as a profession should largely disappear."

Barron added that the electronic typewriter is the key to the information soci-

ety of the future. "It is already cheaper to store information electronically than to use paper and filing cabinets. It is also cheaper to transmit information through the telephone system than to use the postal service. The main barrier to the widespread use of these techniques has been the cost of data capture. Once that barrier is broken, the changeover from

"Improved procedures must be developed to overcome a seemingly immature structure of management functioning."

paper to electronic information should be rapid," Barron said. He added: "Given the progress in semiconductors, it is realistic to expect that completely silicon word-processing systems will soon become feasible."

The major impact of the information revolution will be to increase unemployment, Barron argued. Pointing out that historically, "each time there has been a significant increase in productivity, (it) has been followed by unemployment and a severe depression," he explained that "a substantial proportion of the working population, perhaps 65%, have jobs

which are primarily concerned with information. All of these jobs will be changed by the use of electronic information systems and it may be expected that the new technology will lead to considerable improvements in productivity and hence to a potentially high level of unemployment in the information sector."

R. D. Bright, of the British Post Office, presented a progress report on Prestel (formerly known as Viewdata), the on-line public information service which has been under development in the U. K. for the past five years. Originally, it was planned to conduct a 12 to 18 month trial of the new service beginning in June 1978, and then decide whether to make it permanent. But public response has persuaded BPO to launch the full-scale service during the first quarter of 1979. Prestel will be available initially in five or six British cities and by the end of next year will be offered in a total of 10 cities. "By the end of 1983," said Bright, "it is envisaged that the service may grow to over 50,000 ports capable of supporting up to 3 million terminals."

—Phil Hirsch

(Mr. Hirsch, a frequent contributor to DATAMATION on communications related affairs, once was the magazine's Washington correspondent.)

LET CUSTOM TERMINALS CORP. POINT YOU TO THE SOLUTION.

Now—a proven source for custom-designed terminals and peripherals—Application Engineered. Don't compromise! CUSTOM TERMINALS will build to your exact specifications—at low-cost, and in any quantities.—Terminals that will run reliably in your: • shop • secure areas • office • factory • mines • loading dock, • etc. All products connect to any host CPU in a polled or multi-drop configuration.

optional micro-based local intelligence

TR-10



Low cost, reliable factory floor type data entry terminal . . . Available with badge readers, journal printers, customizable keyboards, and displays, etc.

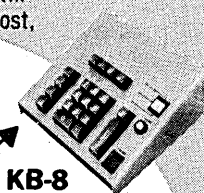

KB-8

Numeric Pad add-on for all peripherals and terminals. Interfaces with all CRT's and printers. (Customizable keyboards)

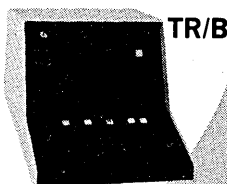
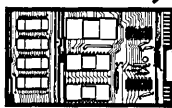

Special purpose multi display data entry terminal . . . Used with mini computerized conveyor systems, etc.



CUSTOM TERMINALS CORP.
A SUBSIDIARY OF COMPUTER HORIZONS CORP.

225 OSER AVENUE, HAUPPAUGE, N.Y. 11787 • (516) 231-3111

SCHEDULIZE with Magnetic Controls

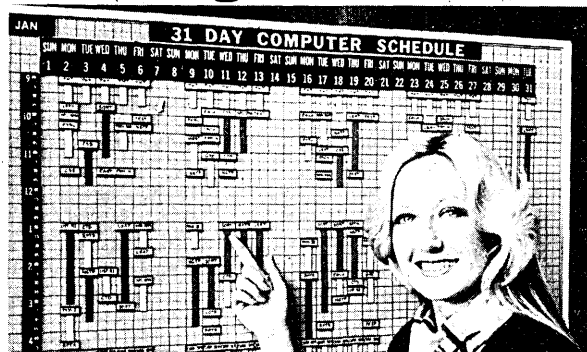

FREE
16 PAGE
ILLUSTRATED
BROCHURE

REPRESENTATION THROUGHOUT MOST OF THE UNITED STATES

- SHOW FACTS INSTANTLY
- CHANGES MADE IN SECONDS
- ELIMINATE FILE REFERRALS
- SYSTEMATIZE YOUR WORK FLOW
- GET THE JOB DONE

For Scheduling • Programming • Personnel • Sales • Shipping • Inventory • Maintenance • Production • Quotations • Computer • Special Situations

201-938-6000

METHODS RESEARCH

70 ASBURY AVE., FARMINGDALE, N.J. 07727

BENCHMARKS

BREAK FOR MEMOREX? Some observers think Memorex Corp. has been throwing money down a rathole in its antitrust suit against IBM which ended in a mistrial this summer when a jury deadlocked (August, p. 56). Last month IBM won a directed verdict by a federal judge which, in effect, held that the giant didn't compete illegally against Memorex. Said IBM chairman Frank T. Cary: "There ought to be a limit to the number of times we must go to trial on these same issues." Although Memorex has spent somewhere between \$1 million and \$1.5 million a year in its suit, it hasn't been counting on a victory to finance its growth, having placed \$50 million in new debt last June and selling 1.3 million shares the next month to raise \$41.5 million. After the directed verdict was issued, Memorex stock dropped 1.5 points, but then rebounded past \$55 a share, a result of the company's recent strong growth. Memorex said it will appeal the directed verdict. (Transamerica Corp., next of the so-called western litigants against IBM, said it will pursue its case against IBM, scheduled for trial Nov. 6.)

AT&T TRIAL DATE: In hearings before the House Communications Subcommittee last August, Assistant Attorney General John H. Shenefield said the government hopes to start its antitrust trial against AT&T in October of 1979. He also hopes the trial will be completed in three to six months, but could take as long as a year. He said the appeal process might take at least 18 months. In a related development, U. S. District Judge Joseph C. Waddy, who had presided over the Justice Department's suit since it was filed, died last month. In late June, District Judge Harold H. Greene took over the case when the seriousness of Judge Waddy's illness had been learned.

NCR IN MICROFILM: NCR Corp. may become the first major mainframer to offer microfilm recorders, even though IBM once sold one but eventually decommissioned it. The Dayton company last month offered \$7.5 million to acquire Quantor Corp., Mountain View, Calif., which in its last nine months has lost \$1,807,000 on revenues of \$15.5 million. Quantor has been making computer output microfilm and microfiche devices since 1969 and NCR has been a major distributor of the line in foreign markets. NCR also offers COM services in its 70 computer centers in the U. S. and abroad. The acquisition first must be approved by directors and stockholders of Quantor, but is expected to be completed before year-end. Said NCR's chairman William S. Anderson: "The acquisition will provide the base for ex-

pansion by NCR in the micrographics and related fields."

CDC ACQUISITIONS: Almost as CDC chairman William C. Norris was condemning "power-play corporation takeovers" before a congressional antitrust committee, CDC announced it had taken over control of Computer Peripherals, Inc. and had become a one-third owner of Scan-Data Corp., the Norristown, Pa., data entry firm. This spring CDC said it would invest \$500,000 in cash and make several supply and marketing arrangements with Scan-Data in a deal which would give them the one-third interest. It rearranged its deal with NCR and Britain's ICL in Computer Peripherals in which CDC and NCR each owned 42% of the company and ICL owned 16%. CDC now owns 60% and NCR and ICL now own 20%. CPI makes tape drives, printers, and mass storage systems.

In his testimony before a Senate Judiciary Subcommittee on Antitrust and Monopoly, Norris said a law is necessary to require stockholders of a predatory company to "exercise more rein over management by voting on unilateral takeovers that are contemplated." Basically he wanted more control over unwarranted takeovers. Norris said that all of CDC's takeovers dealt with voluntary acquisitions and never with acquisitions that were contested.

THIRD ENTRANT: Japan's Mitsubishi Electric Corp. will develop IBM software compatible computers for shipment in 1983 to the Japanese market where IBM holds about 30% of the market. The company said in late August it will budget the equivalent of \$108 million to develop the machines. Hitachi and Fujitsu, two other huge Japanese electrical manufacturers, already make IBM compatible machines.

ADR IN DATA BASES: Applied Data Research of Princeton, N. J., said it hopes to acquire the software business of Insyte Corp., Houston, which sells data base management and teleprocessing monitor packages for IBM mainframes. Officials of both companies said the deal could be completed before year-end. Insyte has some 200 software packages installed at more than 100 locations, while Applied Data has some 8,000 products installed at 5,000 locations. Said ADR's president John Bennett: "Insyte's line will fit into ours quite well because we sell to the same customers."

FIRST INSTALLATION: National CSS, the Wilton, Conn., service firm, announced it has installed the first 3200 minicomputer at its Sunnyvale, Calif.,

data center. The 3200, a 32-bit virtual memory system manufactured by Two Pi Corp., also of Sunnyvale, supposedly was up and running on NCSS's time-sharing network two hours after delivery. James McGuire, president of NCSS's Computer Div., said initial customer deliveries will start as planned in the late fall. The computer, ranging in price from \$200,000 to \$600,000, is the only computer system in its price range, according to McGuire, that can handle all of the major programming languages: COBOL, FORTRAN, PL/1, APL, BASIC and assembler language.

ADD IBM REORGANIZATION: IBM seems to be fostering greater decentralization and autonomy in the company as it continues to grow in complexity. Recently it announced it was studying forming a General Business Group subsidiary (August, p. 76) and last month it announced it was splitting its Systems Products Div. into two separate divisions: The Systems Products Div., headed by Jack D. Kuehler, president, with responsibility for development and manufacturing for intermediate performance range products; and the Data Systems Div., headed by John E. Bertram, president, which will develop and manufacture "large complex systems with primary emphasis on high-performance products." These would be the current 370/303X lines such as the 158 and above. SPD would be responsible for lines such as the 370/148 and below. Industry observers feel the SPD's responsibility eventually would be for the long-touted new product, the E-Series, which will be offered as replacements for the 115 through 148 models of the 370 line. At the higher end, DSD would be geared to handle the H-Series, which is expected to replace the 303X line and to extend beyond it. Formation of the new divisions, both of which report to Paul J. Rizzo, head of IBM's Data Processing Product Group, is understood by analysts to indicate IBM's concern with meeting such competitive threats as plug-compatible mainframes and alternative network plans such as AT&T's proposed Advanced Communications Service.

HINCHMAN SUCCESSOR: Dr. Larry F. Darby, acting head of the Common Carrier Bureau of the Federal Communications Commission since July 15, was named chief of the bureau in August, succeeding Walter H. Hinchman who left the bureau officially last August 31. Dr. Darby joined the bureau in March 1977 and has been chief of its Economics Div. since last fall. He's also been a close advisor of Hinchman.

*

INTERACTIVE CONTROL.

**Why Honeywell's
Level 68/DPS
is the most versatile interactive
information system on
the market today.**

Honeywell's Level 68/Distributed Processing System (Level 68/DPS)—with its Multics operating software—gives more people in more places easier access to data and data processing power. The architecture is designed for a full range of online processing needs.

Managers can access files through online inquiry using English-like statements. Office workers can use the system for word processing, document management, and electronic mail. Engineers and designers can make use of time sharing and interactive graphics. Programmers can develop, debug, and install programs directly from a terminal. Outlying offices can enter jobs remotely.

More productivity for your users.

Administrative tools manage large, diverse terminal-



driven environments. To ensure that the workload of certain users will not impact that of others, users can be grouped into classes and allocated specific percentages of processing capability and response time. Maximum performance is achieved by dynamic metering and tuning.

Controlling and building your data base.

The Multics Relational Data Store (MRDS) offers a fully implemented relational data base capability. Simplified techniques permit data base inquiry and update via high-level end-user facilities. Interactive debugging tools speed up programming and new application development. Another interface using traditional

techniques is available with Honeywell's Integrated Data Store/II (I-D-S/II) system.

Data access and integrity.

Level 68/DPS access control mechanisms give unmatched protection not only to the system, but to data and programs as well. An industry-wide study of computer security provisions conducted by MITRE Corporation for the U.S. Air Force rated Multics number one in security architecture.

For more information, contact your Honeywell representative. Or write to Honeywell, 200 Smith Street (MS 487), Waltham, Massachusetts 02154.

Honeywell

PROJECT PARADISE COMES DOWN TO EARTH

Citibank's decentralization plan is given a second look

by Laton McCartney

"Project Paradise," Citibank's highly touted program to decentralize its corporate data processing operations, has been relegated, temporarily at least, to the back burner as the world's second largest bank seeks to gain greater control over what well may be one of the most ambitious ventures yet undertaken by a dp user.

Started in the mid-1970s when Citibank began replacing its IBM mainframes with minicomputers—at least 250 minis currently are installed in the bank—the Paradise project has been widely heralded as a bold and highly innovative attempt to break away from the confines of the traditional, monolithic dp approach.

The scope of the project is staggering. In touring the various bank departments, each one of which seems to have its own individual data processing operation, one views the latest minicomputers, peripherals, office information processing and data communications equipment from scores of vendors.

Everywhere innovation seems to be the watchword. Much of the gear, such as the Datapoint ARC system the bank's personnel department is installing to handle everything from employee benefits to monitoring hiring patterns, has scarcely hit the market yet.

And some equipment such as the word processing terminals Citibank is incorporating into its microcomputer-based management workstations—terminals that were developed by Lexar Corp. in Los Angeles to Citibank's specifications and with Citibank's funds—hasn't even been publicly introduced yet.

With this enormous wealth of new technology, an ardent data processing devotee needn't die and go to heaven to see his fantasies fulfilled. He or she can simply get a job at Citibank.

Indeed, Paradise was designed to be just that—heaven on earth, or at least Nirvana in a decentralized processing environment. Its benefits, Citibank executives enthused publicly, were multitude: elimination of mountains of paperwork, tremendous savings in reduced manpower, more responsive service to the



ROBERT WHITE, Citibank's executive vice president and principal architect of Paradise, now says the bank's major program is "technological consolidation."

customer, greater access by the user to the dp function, and more direct user control over that function.

Recently, however, it's become increasingly apparent that Paradise may not be quite the unqualified success it's been touted as, and Citibank itself is

Paradise may not be quite the unqualified success it's been touted as.

evidently experiencing some serious second thoughts about the project.

Late last fall, in fact, Robert B. White, the 44-year-old Citibank executive vice president who is the principal architect of Paradise, gave the first indication the project was being reassessed and, in effect, put on hold. One of the bank's major programs for 1978, he announced, would be a "technological consolida-

tion."

Subsequently, Richard J. Matteis, a senior vp who reports to White, told the bank's corporate operations staff, the Service Management Group: "In the past, we were all given carte blanche to try new things, to come up with the most 'far out' kinds of ideas and to test them out in our own worlds. And now it is perhaps difficult to remember that it was never the intention that every program, every project, every effort would be locked in for eternity. Our aim was to try a variety of things precisely *so that* we could select from that variety the ones that succeeded best in practical business terms."

Outside the bank there was speculation that the consolidation was, in fact, forced upon White's group by the bank's top management which wanted to initiate more stringent controls on corporate dp spending that increased 23% in 1976 and 26% last year. "The whole Paradise thing had simply gotten out of hand," says a Wall Street analyst who follows Citibank. "White's group used to make a big point of saying that they weren't technology freaks with a big bankroll to spend on all kinds of new toys, but that's exactly how a lot of people perceived them."

Indeed, the "do your own thing" approach to technology has engendered a number of problems, and disappointments—some minor and others major. Despite its big gamble on the mini vendors and the fact that with its clout, the bank had a direct pipeline to top management within *these* companies, Citibank remains less than enthusiastic about the service it has been receiving. Consequently, the bank is seriously considering setting up its own in-house service organization. "In a macro sense, I don't think the level of service you get is as good as that offered by IBM," notes White.

Conversely, vendors and consultants who've been involved in the project complain that when they've gone in to try to convert a mainframe software program to a mini system, they often would be unable to find any documentation for the previous program. Moreover, the author of the software had frequently vanished into another section of the bank so there was no one around to explain the old

program.

"One of the problems with decentralization," a former Citibank employee notes, "is that when you decentralize, you also disperse your talent. Subsequently, you have to determine where the people are who know what's going on.

"You also had what I call the hyper-mobility syndrome there," he adds, "with lots of aggressive, talented data processing people looking to move up the ladder as quickly as possible. They would come in, write a program, be promoted, and then move on. That's not exactly the kind of environment that afforded continuity or made for a smooth transition."

Additionally, some segments of the bank's corporate processing—particularly where it interfaced with outside institutions like the Federal Reserve, which operates on a centralized dp structure—simply couldn't be "Paradised" at all, at least not for the time being.

As a result, some of the bank's early repudiations of mainframe architecture came back to haunt it. For example, speaking before a distributed processing seminar early in 1977, then Citibank vice president Jon S. Gould confidently outlined the bank's plans for eliminating its two remaining IBM 370/158s through downward migration. Within a year the 158s would be replaced by four to six 145s or 148s. Gould said, after which a dozen or so PDP-11/70's were to be brought in.

Today, in fact, the 158s *are* being replaced, but by an IBM 3031. White, however, maintains that the 3031 is "definitely coming out in 1979," and will then be replaced by minis.

Certainly the most troublesome phase of Paradise, though, involved efforts by the bank's Securities & Government Services Group to replace an IBM 370/165 with eight Interdata 8/32s, which were due to be fully operational by July 1975.

At the time, the 32s had just come onto the market and a source close to the Citibank acquisition of the machines explains they were selected primarily because Citibank insisted that the stock transfer processing be done in COBOL. The 8/32s boasted a COBOL compiler, while other mini-vendors in competition for the contract, like DEC, did not have a COBOL capability.

The Interdata machines had hardly been unpacked from their shipping crates when then Citibank vice president John L. Hughes, who was responsible for the project, began extolling the merits of the new decentralized system. The bank, he told DATAMATION, would cut in half previous annual processing costs for stock transfer that amounted to \$2.8 million for the IBM hardware.

The only real problem Hughes foresaw was the difficulty in overcoming what he termed the "IBM mental set." "You must

get your people to think in terms of functional systems, and small modular programs," he advised. "Do not accept any excuses as to why their program or system is unique and cannot be converted to a mini."

Overcoming the IBM mental set, however, turned out to be the least of Hughes' problems in converting the stock transfer application. Among other things the In-

terdata hardware and software mix reportedly was not capable of allowing the multitasking that was critical to the application. The power of the 8/32s couldn't be utilized effectively because the I/O transfer rate (one channel transfer had to be completed before a second could be initiated) slowed access down enormously. And the COBOL compiler, which had been key to Interdata's land-



CITICORP'S NEW CORPORATE HEADQUARTERS—No more "carte blanche."

ing the initial \$2 million contract, was so new that neither Citibank nor Interdata knew how to make it function effectively.

The upshot of the Interdata venture was that the bank's stock transfer system was in such chaos that at one point Citibank reportedly had to enlist the aid of other banks to handle some of its transactions. In addition, it lost some of its major institutional clients such as Merrill Lynch, Pierce, Fenner & Smith.

To rectify the situation, Citibank has spent upwards of \$10 million writing new software for the stock transfer operation, it is estimated. The bank also is reported to have brought in a small army of consultants and eventually established a centralized data center management group under bank vp Max Gould to control the decentralized effort. Further, the creation of the group "allowed us the leverage to get what we wanted out of Interdata," adds Robert Gottlieb, another bank vp who now manages the stock transfer operation.

Today, with some 35 8/32s (at a total hardware cost of about \$10.5 million) and a host of additional equipment such as Wang small processors for on-line certificate issuance and Compuscan word processing gear to log customer inquiries, the securities operation apparently is functioning smoothly.

In retrospect, White maintains the problems that arose had to do with the way the operation was managed rather than with the decentralized philosophy that lies at the heart of Paradise. "The people we had in charge of that operation were not technically ready to run a brand new hunk of hardware and software," he explains.

Candidly, White also concedes that if he had a chance to do the stock transfer operation over again, he'd probably use the DEC 11/70 gear rather than Interdata. Moreover, he doesn't preclude eventually replacing those Interdata machines with DEC equipment.

In the wake of the stock transfer experience and the consolidation effort, Citibank is busy sorting out the weeds from the flowers, to use the bank's analogy. "We had a period we called 'let all the flowers bloom,'" Dick Matteis explains. "A number of projects developed during that period proved more successful than others, and now we're selecting the better projects and developing them to serve as building blocks for the future."

Chief among these building blocks is the Corporate Banking Station, or CBS. Here processing is broken out by corporate clients which use such Citibank CBS products as letters of credit and investment management monitoring tools.

Citibank has designed the system so that the data for perhaps five or six corporate customers is stored on an 11/70. (Originally the 11/70s were devoted



CARL L. HOWARD



ROBERT GOTTLIEB, who manages stock transfer operation (left) and Bruce Hasenyager, who heads bank's Text Communications staff.

to product, rather than customer, data bases, but Citibank has recently changed that.) The machine in turn is accessed via crt by the manager who is responsible for dealing with those half dozen or so corporate clients on the computer. Again the philosophy here reflects the thinking behind Paradise: First, give management direct access to the dp function which handles its customer's processing; second, make sure the customer's requirements are the prime consideration in designing the processing structure.

Citibank is also high on the management workstation, which typically incor-

A digitized phone can tie the terminal into Citibank's digital network or be used for voice communications.

porates two Lexar text editing and display terminals, a Qume printer and a microprocessor for distributed processing and data storage within the workstation environment.

Additionally, the bank is using a digitized phone that can tie the terminal into Citibank's digital communications network, CITINET, or can be used for voice communications by personnel at the workstation. "I'm already satisfied that the workstation is successful in bringing together computer and communications capabilities into the office environments," says Bruce Hasenyager, who heads the bank's Text Communications staff.

And while these programs and other efforts such as Citibank's Global Com-

munications Network and its new check processing system are being carefully nurtured, the bank has begun taking a more controlled and integrated approach to the various and diverse outcroppings of its "let all the flowers bloom" phase.

It is installing data capturing mechanisms in a program called Citiproof to track transactions that have a financial impact on the bank. Concurrently, an MIS system dubbed IAMUS is under development so that the bank's top management and its own internal financial people can monitor spending within the various bank departments.

Even more significantly, the bank has spent more than a year modifying and customizing the DECNET-RSTS data communications software so that it ultimately could function as standardized front-end software architecture for the entire Citibank corporate dp operation. "This can serve as the nucleus for future systems as we add new applications," White says.

Further, the newly formed Communications and Processing Group headed up by Matteis has as a major objective, as Matteis says, "to support the integration process—to help fold in our recent achievements throughout the processing environment so as to bring them into the mainstream of our thinking and planning and acting."

The linchpin of the integration process is CITINET, the packet-switched network the bank is putting into operation. Utilizing Arpanet software customized for the bank by Bolt Beranek and Newman, the network, which employs Honeywell Level 6 minis as distributed nodes, now is being interfaced with the various mini-

DATA SECURITY?

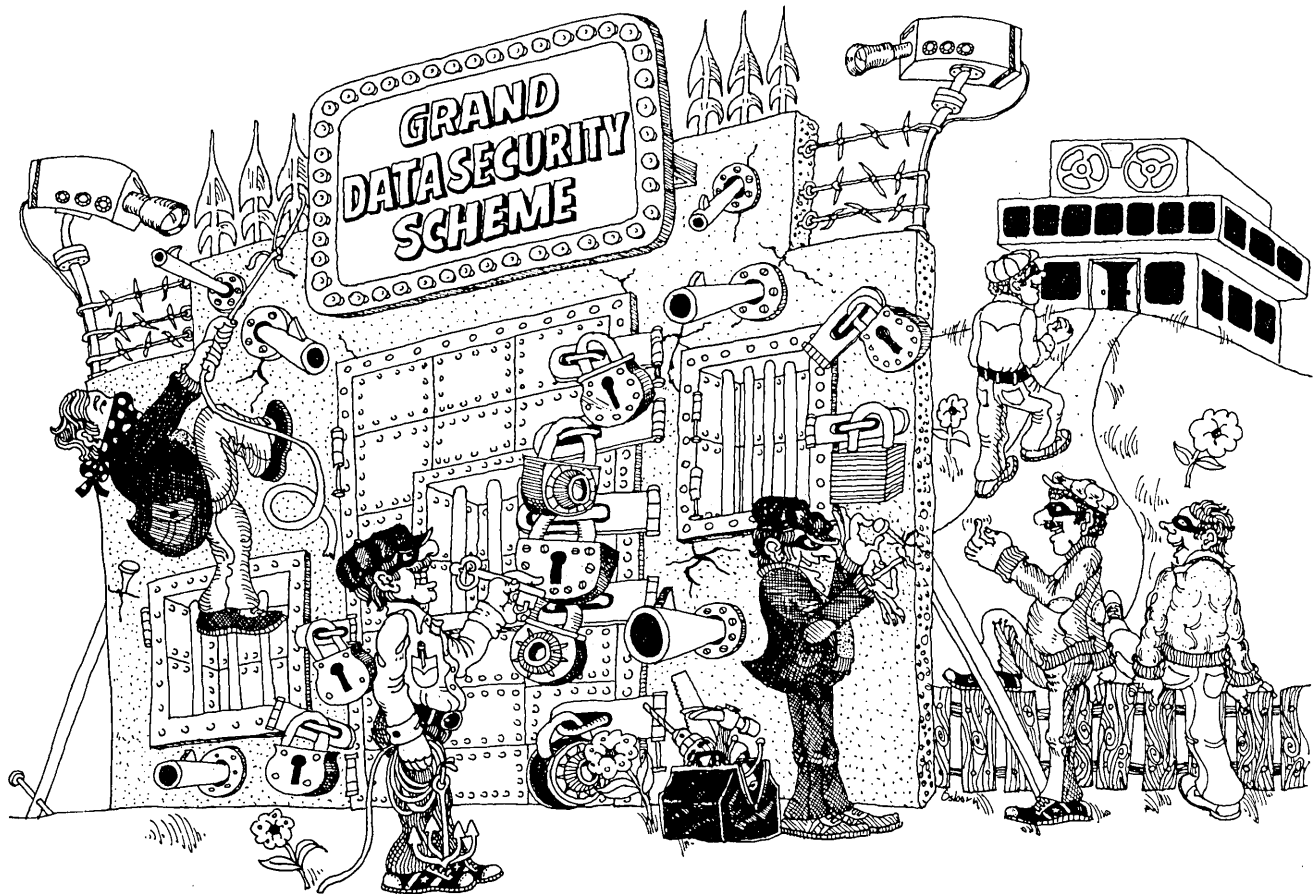

Does the data security system you are evaluating address the two *most* fundamental issues of computer security:

- 1) *identification* of potential users of your computer system, and
- 2) the *authentication* that potential users are, in fact, valid users?

If the security system you are evaluating is SECURE™, the answer is NO!

In addition, SECURE™ is not oriented to decentralized control via delegation of access authorization to your users.

The IBM offering, RACF will identify and authenticate, and will allow decentralized control but it will also substantially degrade the performance of your system and may require additional resources (at least a dedicated disk-drive for the RACF data set) in order for you to protect any reasonable amount of data.

The *only* product which combines complete data security with truly brilliant system performance is ACF2!

ACF2 protects all of your data, identifies and authenticates users, and allows delegation of access authorization to the owner of the data. In addition, ACF2 may be implemented easily and gradually, and provides audit trails of violation attempts and reports on such activities.

ACF2 gives you flexible and functional software security with minimal administrative and system overhead.

Complete, high-performance software security. You can't afford to settle for anything less.

ACF2 (Access Control Facility)

The Cambridge Systems Group

19857 Beekman Place, Cupertino, California 95014, (408) 255-5727

ACF2 was developed by SCHRAGER KLEMENS and KRUEGER, INC.

CIRCLE 56 ON READER CARD



CITIBANK is estimated to have spent \$10 million to write new software for its stock transfer operation.

CARL L. HOWARD

computer and mainframe systems that make up corporate processing.

Here Citibank seems to be paying the price for its technical diversification. The price tag for each software interface amounts to \$50,000, bank executives estimate. Moreover, the do-your-own-thing atmosphere that prevailed in selecting minis is not evident here. "If someone needs computer to computer communications, we won't fund the project unless they come on to the network," Matteis asserts.

In effect, then, Paradise, is being brought back down to earth. With the consolidation effort, White now seems determined to use this technology not only to ensure savings in the form of fewer employees, but to generate profits and bring in new business as well.

Though it has generated revenues in the past by processing New York City income taxes and the city's parking violations, White's group hasn't really had much success in this area. It lost out on a three-year, \$100 million assignment to process New York's Medicaid program, and efforts to enter the time-sharing market were hamstrung by a suit initiated by the Association of Data Processing Service Organizations.

However, bank observers say that

White's group is anxious to have a greater impact on the bank's bottom line now because of a rivalry with Citibank executive vp John S. Reed, who heads the Consumer Services Group—the equivalent to White's group on the retail side.

Reed, who initially hired White, has spent an estimated \$175 million in automating retail banking operations and in aggressively trying to capture a bigger share of the retail market. A former Citibank executive says that White has become increasingly profit conscious as a result of Reed's efforts.

Already, SMG has begun selling its money management services—complete with a terminal installed in the customer's office—to big corporate clients, directly competing with firms in the field like Rapidata and National Data Corp. The latter ironically supplies the same service to Citibank.

Further, White currently is evaluating the potential market for the text processing terminal and the workstation. "We're looking for ways we could package this approach and sell it to other people," he notes, "but we're constrained legally because a bank can't sell hardware."

Even if Citibank were not constrained, however, it would face a problem in marketing the Lexar equipment it fund-

ed. Lexar officials say that the product is entirely theirs, and that Citibank has no claims upon it unless Lexar licenses another company to sell it. Then Citibank would receive a portion of the licensing fee.

Whatever happens with Paradise, in White's view at least, the project has accomplished its primary goals. The Citibank back-office staff has been cut back, and the bank today is far more responsive in dealing with its customers than it was in the pre-Paradise era, White claims. Further, the problems that have surfaced in implementing Paradise don't really count for much in the context of the overall objective of making Citibank a more efficiently run business, White maintains.

"You can optimize the edp arena, but often that optimization comes about at the expense of the business itself," White explains. "Our operations are dramatically inefficient in a data processing sense, but we're much more efficient in a business sense as a result."

If White is right, the dp hierarchy may have to throw out the conventional rule book and go by a whole new set of guidelines. If he's wrong, it certainly won't be for lack of boldness or imagination. *

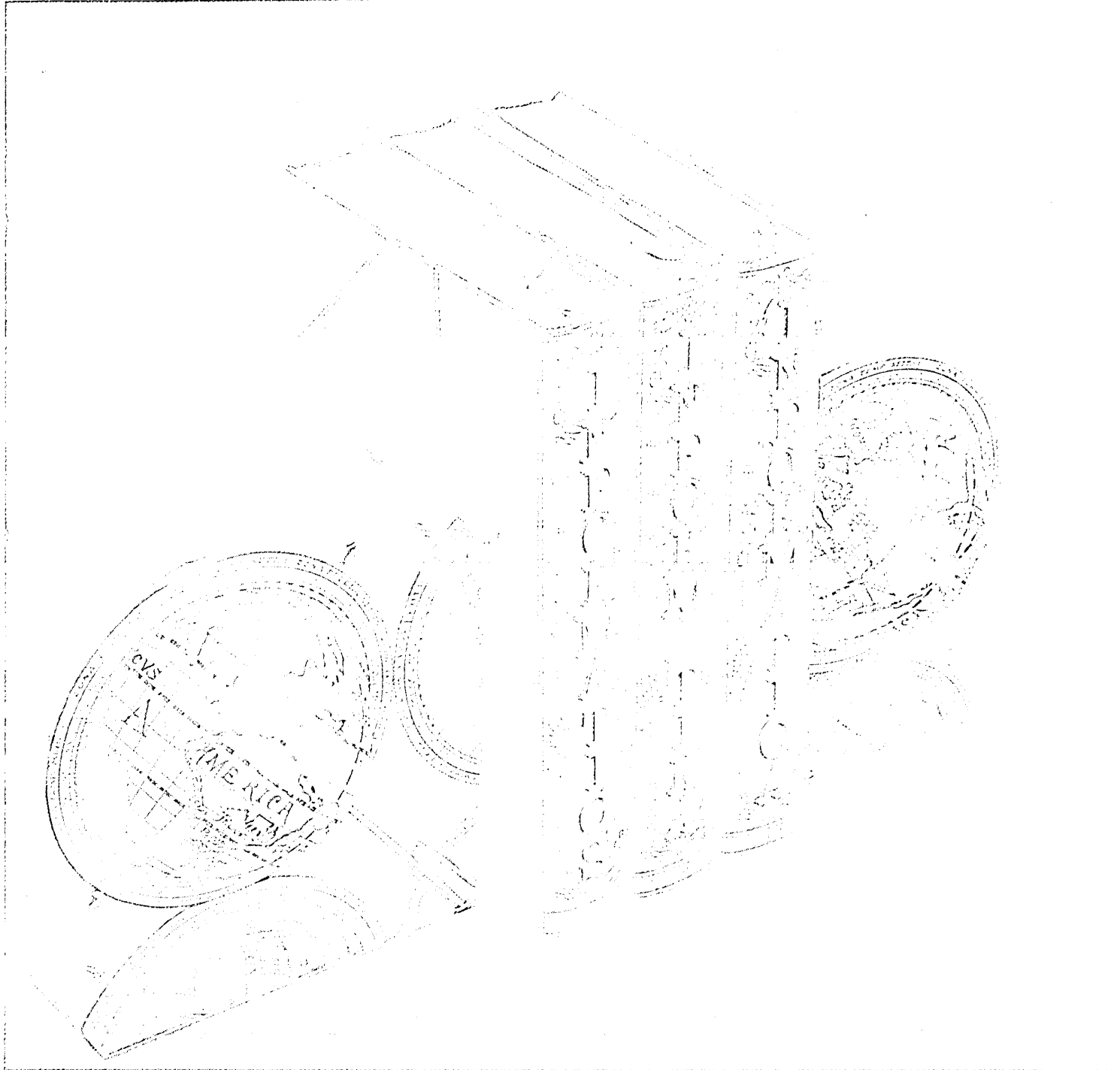

Wherever it's said, however it's spelled, Informatics[®] fulfills the promise of the computer... universally.

Informatics introduced the world's leading products with the ultimate in modern data processing in the United States and many other countries. It's all in our products and services of Informatics Inc. One part of the ever-expanding Informatics world... our broad range of software products. We're best-known for MARK IV, the general purpose implementation system for IBM's System/370 and compatible in 42 countries. But we have more to be proud of... some of these are other implementation systems for IBM's System/370 and System/360. And... our products are designed for specific IBM 360/370 environments... like the COMM and CRJ II - COMM products. And... our products and our ACCOUNTING IV[®] line of products for general

business accounting. Informatics Inc. is the world's leading independent software supplier. Drop us a line on your air-mail and we'll send you a colorful brochure that tells how we can help you fulfill the promise of your computer.

SOFTWARE PRODUCTS
PROFESSIONAL SERVICES
INFORMATION PROCESSING SERVICES

informatics inc

INFOCUS

Corporate Offices: 27001 Ventura Boulevard, Woodland Hills, California 91364 (213) 387-9040/Telex 69-8470

Member SIA and IFA IBM and OS/360 are registered service marks and trademarks of Informatics Inc.

© 1978 BY READERS EARL

The complete printer/plotter. Only from Versatec.

Suddenly the computer world is filled with printers that claim they can plot. Don't be fooled. Versatec gives you the best performance per dollar of any printer/plotter made.

The Versatec 1200A is more than a line printer with graphics pretensions. It gives you true plotting and gray scale quality. And it delivers that quality with more than twice the reliability and one-tenth the noise of impact devices. No wonder the 1200A is the world's most popular printer/plotter.

New enhancements. The 1200A image is darker, more consistent. Fewer adjustments are needed. One second startup time.

Exclusive features. Convenient 25° viewing angle. Variable line spacing. Easy contrast adjustment. Differential paper drive. Sealed paper compartment. And twelve other features you won't

get from other printer/plotters.

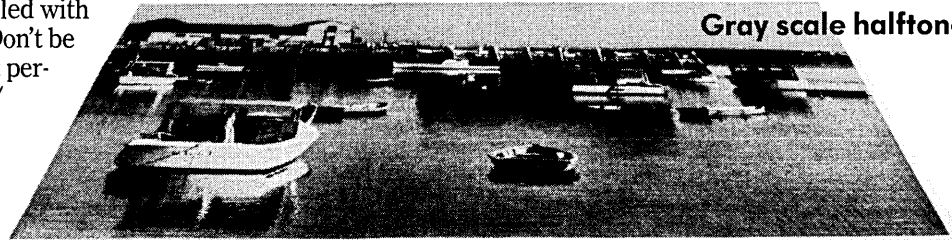
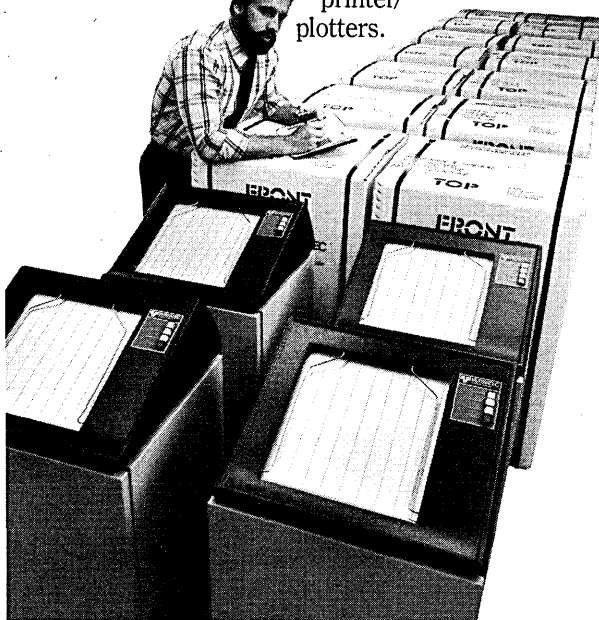

Gray scale halftones

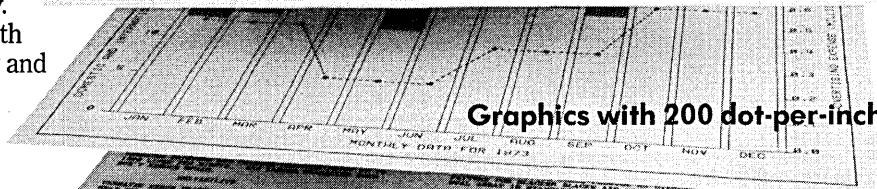

Graphics with 200 dot-per-inch resolution

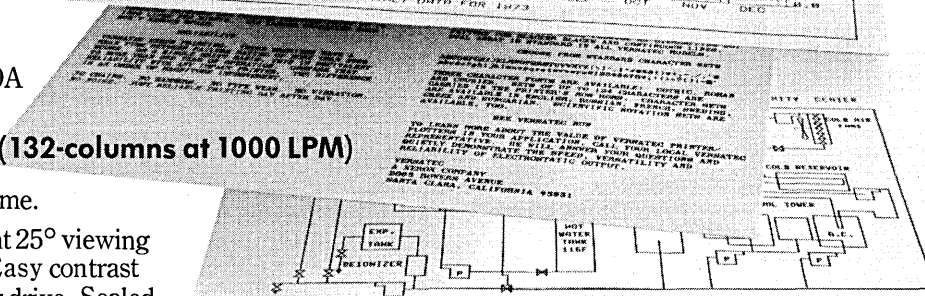

Printout (132-columns at 1000 LPM)

CRT hard copy from display terminals

Plug-in compatibility. The Versatec 1200A interfaces with all popular computers and display terminals. Print/plot drivers and Versaplot™ graphics software link with your operating system and existing application programs.

Your investment is protected if you decide to trade up to Versatec wide plotters. The entire hardware/software interface is upward compatible.

Total support. Service Centers in 19 U.S. cities and 38 countries.

Full service warranty plans. Software support. Training. Toll-free* supplies ordering. You have it all with Versatec.

Get the complete story. Circle our readers' service number for 1200A literature and unbeatable samples.



2805 Bowers Avenue, Santa Clara, California 95051 (408) 988-2800

*Except in California.

Versaplot is a Versatec trademark. © XEROX is a trademark of XEROX CORPORATION.

DatagraphiX[®] AutoCOM

The microfiche system that
converts computer output to cash.

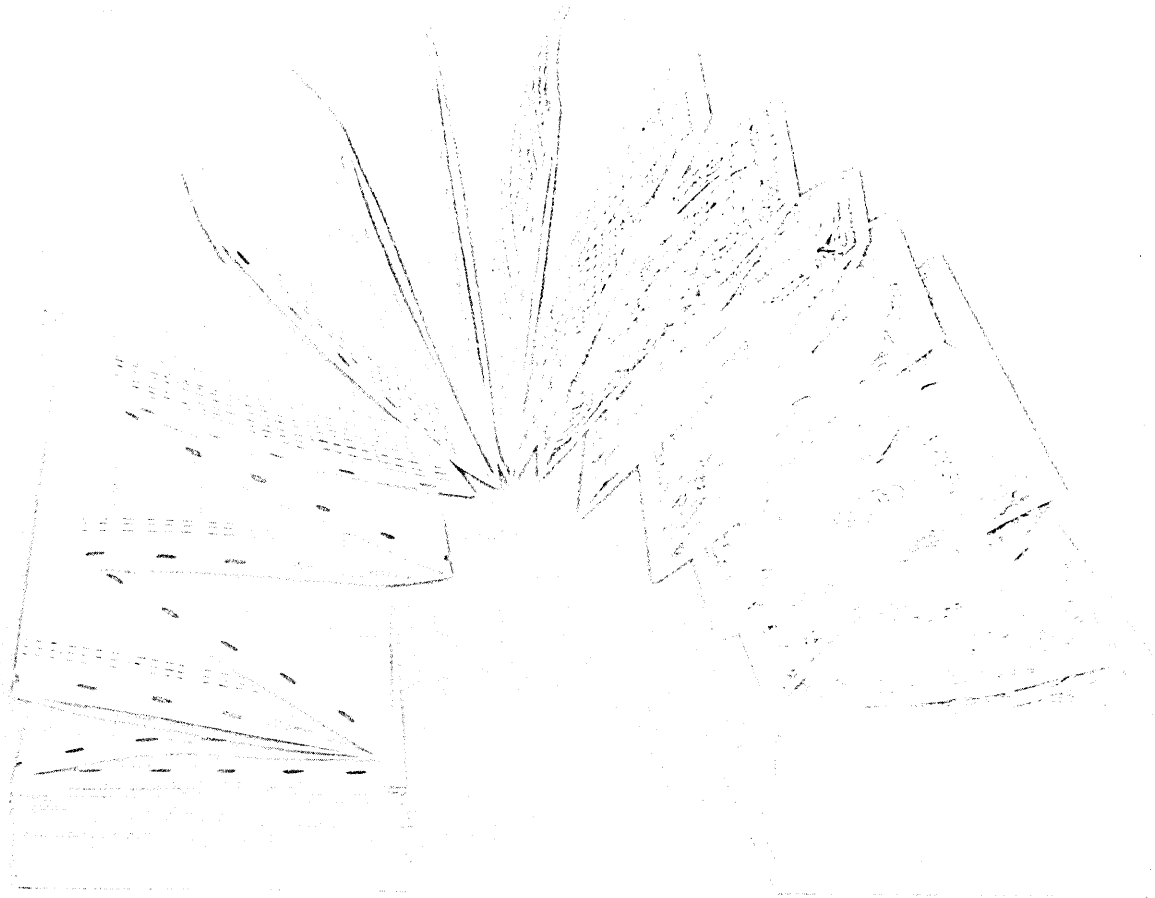

Less
of this.

More
of this.

A 40% return on your investment?

An AutoCOM[®] microfiche recorder from DatagraphiX can turn your costly computer-based printing system into a real money saver. In many cases, in-house paper users with as little as 100,000 pages of monthly computer output can generate a 40% return on their AutoCOM investment with a 2½ year payback period.*

And that's just one of the advantages of film over paper. AutoCOM also means faster information turnaround, more efficient data distribution, and quick, efficient data retrieval.

Now just look at what DatagraphiX offers. State-of-the-art equipment, fast installation. The COM industry's largest service organization. And all the expertise of the people who invented COM nearly 30 years ago.

Once you've added up all the benefits, start adding up real dollar savings for your operation. Send for complete information today... and find out how the DatagraphiX AutoCOM microfiche system can help you save more with less.

*Based on our financial analyses of information received from over 200 businesses.

CIRCLE 82 ON READER CARD

O.K. Show me how to save more money with less paper.

- Send me complete literature on AutoCOM.
- Please arrange a financial analysis of my potential savings with COM.
- Have a sales representative call.

Name/ Title _____

Company _____

Address _____

City/State/Zip _____

Telephone _____

DatagraphiX

a General Dynamics subsidiary
P.O. Box 82449
San Diego, CA 92138 • (714) 291-9960

DatagraphiX[®] is a registered trademark
of DatagraphiX, Inc.

D9A

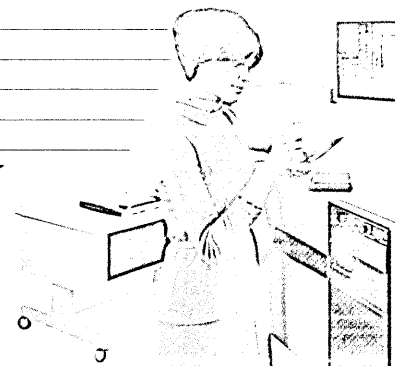

“If you're scared,
you make a decision
that's safe.

If not, you make
a decision that's right.

What we try to do
is remove the fear.”

Tom Knight
Product Manager



370 Add-on Memory

“We really believe that you can't do better than National's add-on memory for your IBM 370 computer. And so do a lot of other people. So I tell customers, 'look, right now there are hundreds of IBM 370's in the field using National Semiconductor memory. If you haven't heard our name it's only because until now, we haven't been selling directly to end users'.

But we actually have a larger share than anyone else in the 370/158 and 168 add-on market. We've delivered over 1200 megabytes. And with 30% of our business today going

to upgrading existing customers, we must be doing something right.

Now, National is offering 370 add-on memory direct — both the 158 and 168 models, as well as our Universal Memory, which interfaces with IBM's 135, 138, 145, and 148 processors.

I really believe we know more about 370 memories than even IBM. Because not only do we have to know intimately every component that goes into our products, we also have to know the IBM CPU's to which our products attach. This knowledge lets us make our memories less expensive

than IBM's, and better — than IBM's or anybody else's.

Beat the heat.

We build our IBM add-on memory with top-drawer, high density chips. All the bits work. So unlike most of our competitors we need no back up chips, no extra circuitry.

Our switching power supplies are twice as power efficient as linear units. They dissipate far less heat.

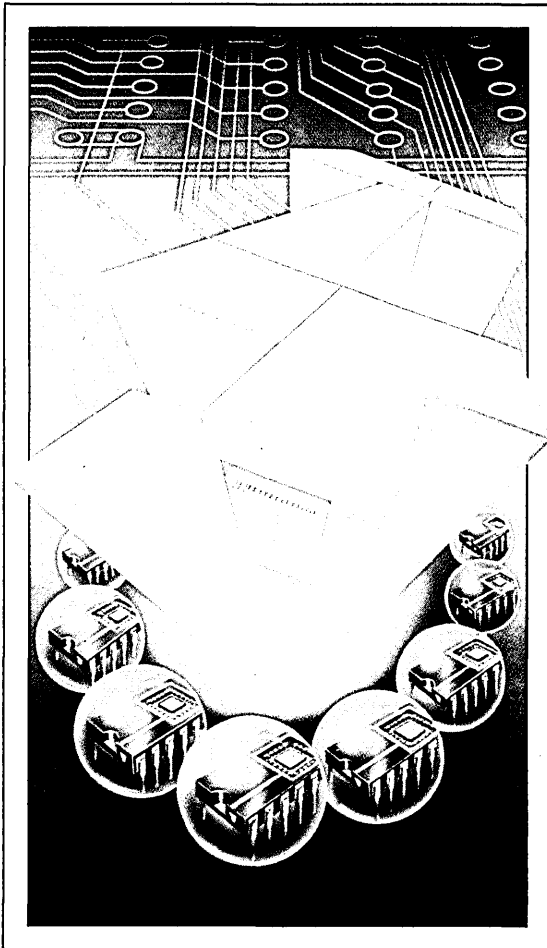

Which means we can run cooler on less power than any other 370 add-on anywhere. And they keep the juice flowing during power interruptions as long as 50 milliseconds.

Size? Our add-ons are the most compact in the industry. Sixteen megabytes can fit into a single frame.

You'd be shocked at how many times we make a sale just because our units fit where others won't.

For easy maintenance, our memory components are socketed. So in the rare event of a failing component, it alone needs to be replaced, instead of a whole printed circuit card.

We also make full use of IBM's error correction circuitry. Single-bit errors have no effect on system operation. Our advanced error detection circuitry and software diagnostics allow us to identify and replace failing components during scheduled maintenance. And with single-bit errors under control, double-bit errors just don't happen.

Take a bold step.

You know and I know that your D.P. budget is spent for system performance. Extra memory means extra performance. And National gives you more memory for your money. The equation is simple.

We understand the "safe" feeling you get by going with IBM memory. But consider. National has a bigger market share than any other independent supplier. We've been deeply committed to 370 add-on memories for years. We can meet all your 370 add-on requirements, whatever they may be, now and in the future.

If you still feel safer with IBM memory from IBM, fine. But if you want to take that bold, bold step and find out more about IBM System/370 add-on memory from National, contact me personally: Tom Knight, Product Manager, National Semiconductor Corporation, Drawer 3, 2900 Semiconductor Drive, Santa Clara, California 95051."

Computer Products Group
≈ National Semiconductor Corporation

Racal-Milgo's new modems make sure you get every millisecond's worth from your data channels.

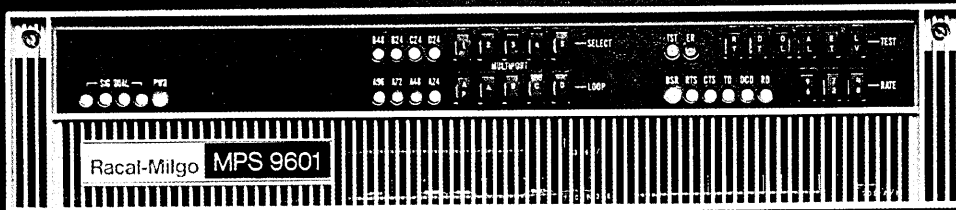

The MPS 9601 series includes 6 models of synchronous modems that deliver full 9600 bit-per-second data transmission in both point-to-point and multipoint networks. The modems offer unique cost saving advantages such as FASTRAN™ ultra-fast 30 millisecond response time and DYNAPORT™ automatic channel allocation as well as multipoint operation and modem sharing. Models are available with CCITT/V.29 modulation.

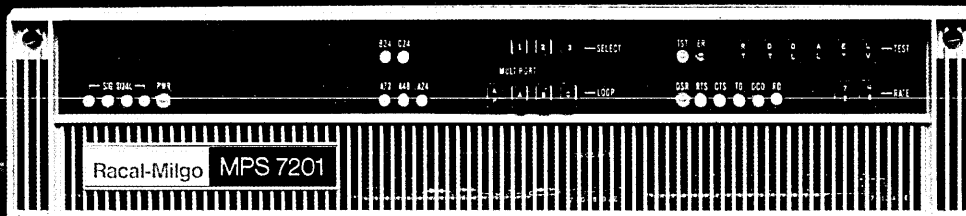

The MPS 7201 modem series provides synchronous 7200 bps data communication over unconditioned lines in point-to-point or multipoint networks. Four models offer a selection of high efficiency features that include up to three independent ports, FASTRAN ultra-fast response time, diagnostics and DYNAPORT automatic channel allocation.

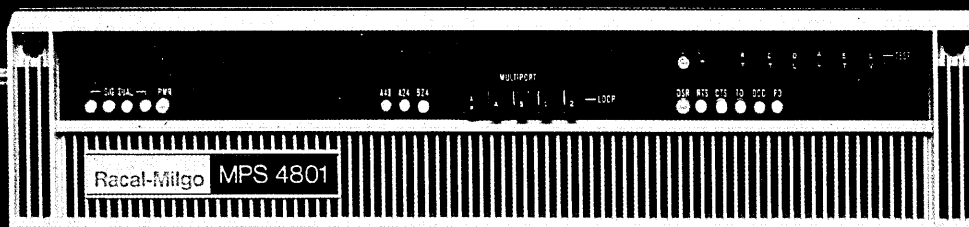

The MPS 4801 series offers optimum 4800 bps data communication over unconditioned lines in point-to-point or multipoint networks. Modems in this series are available with either a single 4800 bps data port, or with two 2400 bps ports. Cost-saving options, including DYNAPORT and FASTRAN, are available in this series.

The exceptional advantages offered in this new series of microprocessor-based modems are fully described in our 12-page brochure. We'll gladly rush you a copy.

Racal-Milgo™ — the new name for **ICC**

RACAL
The Electronics Group

Racal-Milgo Information Systems, Inc.

8600 N.W. 41st Street Miami, Florida 33166 Telephone (305) 592-8600 TWX: 810-848-6588

© 1978

In Europe: Racal-Milgo Limited, Reading, Berks, England

member of
IDCMA

CIRCLE 105 ON READER CARD

TEXT-5

THE SYSTEM DESIGNED FOR THE PRODUCTION OF TECHNICAL PUBLICATIONS.

Powerful text editing and large data base management was a major design requirement for the TEXT-5, along with the ability to compose both military and commercial formats and produce high quality photocomposed camera-ready copy.

Composition requirements are easily achieved without complex coding structures imposed upon the operator. TEXT-5 was designed for upward expandability to keep up with your Publication Department's changing environment.

We know your production problems and have designed the TEXT-5 system to fulfill both your current and future needs.

Write or call us and we will be delighted to send you a complete package on our products.

1050 Rancho Conejo Boulevard
Newbury Park, California 91320
(805) 498-9611 (213) 889-7400
TWX: 910-336-1541

See us at Graph Expo '78,
Booth #4436.



**AUTOLOGIC
INCORPORATED**

Manufacturer of the APS-5
Family of Phototypesetters

Dp professionals are not like those in other fields.

WHAT MOTIVATES DP PROFESSIONALS?

by J. Daniel Couger
and Robert A. Zawacki

On a recent trip to Des Moines, we were forced to make a change of planes in Lincoln, Nebraska. While we were waiting in the terminal, another passenger made a surprising seat request. He wanted to sit in the middle seat in the three-abreast arrangement of the Boeing 727. One of us asked the Frontier clerk if

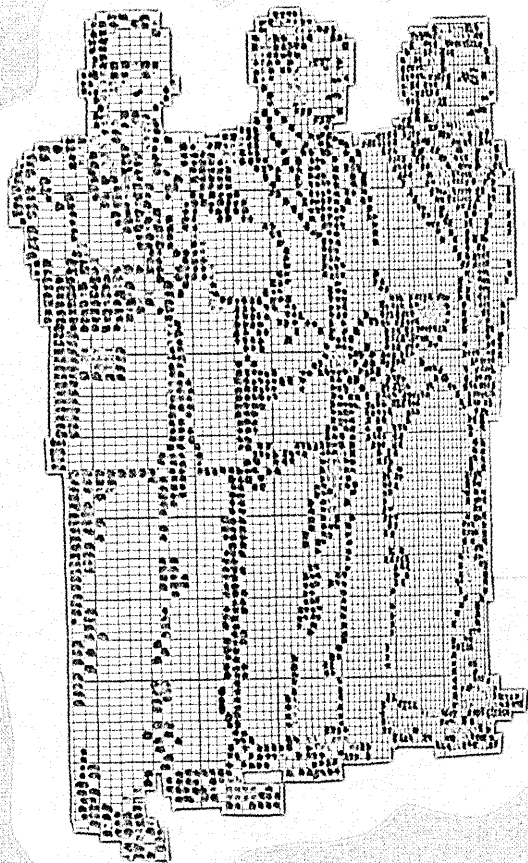

this request was as unusual as we suspected. "First time it ever happened in my five years with the airline," he responded.

Odds are that this passenger wasn't a programmer or an analyst. We have just concluded the first part of a survey on what motivates dp employees. The survey revealed that systems professionals have a startlingly low proclivity to social interaction. In fact, the results showed that these jobholders have

negligible need to work with other individuals.

It follows that programmers and analysts are not necessarily seeking the kind of interaction that programming team concepts are imposing. (Other results suggest that systems professionals won't readily take to the increased specialization that team concepts call for either.) These approaches might be well accepted in other fields, but their implementation requires special consid-

erations for dp personnel.

Dp professionals are different from others in a variety of ways, the research shows, including having a higher need for personal growth than other professionals do. The results show much more too, verifying some of the suspicions we have always had about dp professionals, and providing some surprises in other areas.

We're learning that the computer profession, now more than 25 years old,

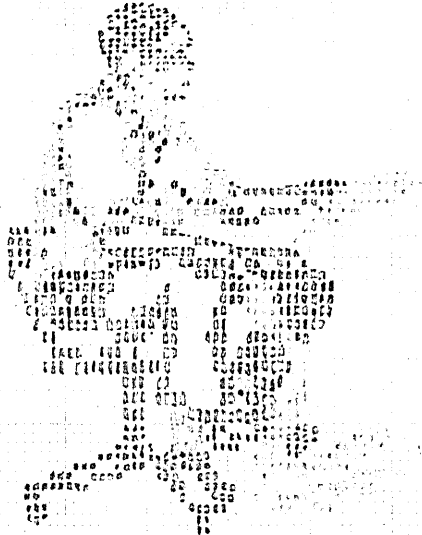

They have a stronger need for personal growth than any other professionals exhibit. . .

may be assuming some of the behavioral problems characteristic of older disciplines, such as engineering and accounting. Worker alienation is a major problem in many fields today. Jobs have not kept pace with changes in our society such as in worker attitudes, aspirations, and values. Managers have attempted to reduce alienation and improve the quality of work life by trying a plethora of ideas for humanizing work, including sensitivity training, management by objectives, shortening the work week, expanding worker involvement in the decision making process, etc.

Those old signs of job dissatisfaction are emerging in the computer field too. Although the aura of excitement of a dynamic field continues to attract persons into the profession, it no longer retains them. Individuals are seeking a more meaningful experience than just being part of a fast growing profession. The job itself must produce the essential elements of satisfaction.

The behaviorists have identified factors key to motivation and satisfaction in other disciplines. But are they the same for our profession? Even if they are identical, does each factor have the same degree of importance in our field as in others? What does motivate the dp employee?

A straightforward way of answering those questions is to compare the data processing professional's perceptions of their jobs with job perceptions of other professionals. This can be done using the model in Fig. 1.

KEY JOB FACTORS The model identifies five important characteristics of a job (called "core job dimensions" by the originators of the model). Skill variety (tasks that challenge the individual's skills and abilities), task identity (completing a "whole" and identifiable piece of work), and task significance lead to experienced meaningfulness of the job. Task autonomy leads to experienced responsibility for outcomes of the job. Finally, feedback concerning effectiveness of the employee's efforts provides knowledge of results of the job.

Since the model has been used to collect information on other professionals, it allows us to compare dp professionals to some kind of a norm. It turns out that systems analysts and programmer/analysts rate their jobs higher, in terms of the existence of these

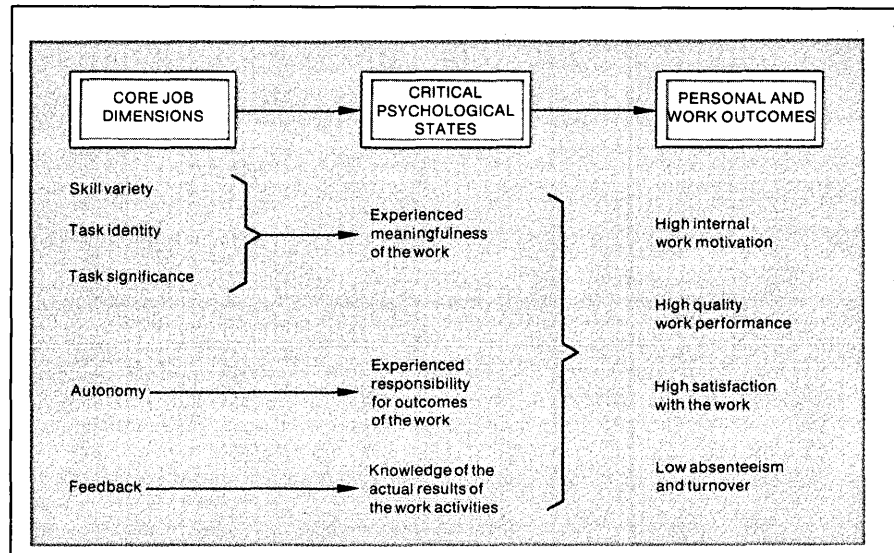

Fig. 1. According to the behaviorists' model, developed by Hackman and Oldham, the presence of five key job characteristics leads to the employee feeling that he experiences meaningfulness from his work, responsibility for outcomes of the work, and knowledge of the results of the work. These "critical" psychological states," in turn, lead to high productivity and low job turnover.

Numerous studies have been done using a Job Diagnostic Survey, to determine whether those core job dimensions are available in various jobs. The authors have tailored the survey mechanism to fit dp employees, making it possible to learn how dp employees see their jobs and whether their perceptions of their work differ from those of other employees.

Core Job Dimension Factors	Data Processing Professionals			Other Professionals
	Analysts	Prog./Analysts	Programmers	
Skill variety	5.55	5.45	5.23	5.36
Task identity	5.37	5.29	5.00	5.06
Task significance	5.75	5.72	5.46	5.62
Autonomy	5.31	5.48	5.13	5.35
Feedback from job	5.20	5.05	5.10	5.08

Table 1. Data processing analysts and programmer/analysts rate their jobs higher in terms of key job characteristics than do "other" professionals. Programmers, on the other hand, rate their jobs lower.

The "other professionals" data comes from studies by Hackman and Oldham of over 6,000 persons in the sciences, law, religion, education, writing, art, and entertainment and recreation fields. (Scale: 1 to 7.)

key job dimensions, than other professionals do. However, programmers rate their jobs slightly lower than other professionals do. (See Table 1.)

The model identifies three "critical psychological states" associated with high levels of internal motivation, satisfaction, and quality of perfor-

mance—and with correspondingly low levels of absenteeism and job turnover.

The two behaviorists who developed the model, Greg R. Oldham from the Univ. of Illinois and J. Richard Hackman from Yale Univ., use the three "psychological states" experienced by a golfer to illustrate the

effect of core dimensions: "Consider, for example, a golfer at a driving range, practicing to get rid of a hook. His activity is *meaningful* to him; he has chosen to do it because he gets a 'kick' from testing his skills by playing the game. He knows that he alone is

responsible for what happens when he hits the ball. And he has *knowledge of the results* within a few seconds." (J. R. Hackman, G. R. Oldham, Robert Janson, Kenneth Purdy, "A New Strategy for Job Enrichment," *California Management Review*, 1975, vol. 17, no. 4,

pp. 57-71.)

1. *Experienced meaningfulness.* The individual must perceive his work as worthwhile or important by some system of values he accepts.

2. *Experienced responsibility.* He must believe that he personally is

ABOUT THE SURVEY PROJECT

We began our research project with the hypothesis that data processing professionals *are* different. We sought to identify key variables in job satisfaction and motivation. The ultimate objective is to identify ways in which jobs can be redesigned to improve satisfaction and productivity.

Our research team (a computer scientist and a behavioral scientist) organized the project into three phases, only the first of which has been finished. *Phase I* involved identifying norms for the field. We surveyed data processing personnel in 25 organizations, both in industry and government. The industries represented include: food processing, airlines, electronics, retailing, banking, insurance, and mail order sales. Their data processing organizations ranged in size from 25 to 150 employees and were located in all geographic regions of the United States.

The government organizations included operations at the city, state, and federal level. Their dp groups varied in size from 30 to 200 employees, and were located in 15 states.

Together, more than 600 dp professionals (analysts, programmer/analysts, and programmers) were surveyed, as were more than 1,000 persons in other dp jobs. Tentative findings are presented here on the motivating potential of the three types of "professional" jobs within our career field, and on the motivation patterns of the people in our profession.

Phase II of the project will continue through next year. In it, five to eight firms in five different industries (including, incidentally, the software development industry) will be surveyed to determine the interindustry differences. Government versus private industry comparisons also will be made.

To what extent does doing the job itself provide you with information about your work performance? That is, does the actual work itself provide clues about how well you are doing—aside from any "feedback" co-workers or supervisors may provide?

1 - - - - 2 - - - - 3 - - - - 4 - - - - 5 - - - - 6 - - - - 7

Very little; the job itself is set up so I could work forever without finding out how well I am doing.

Moderately; sometimes doing the job provides "feedback" to me; sometimes it does not.

Very much; the job is set up so that I get almost constant "feedback" as I work, about how well I am doing.

In *Phase III*, which will go on through 1980, we will use techniques proven in other fields to analyze dp jobs for ways to improve job satisfaction, employee motivation, and productivity. This research will include all jobs within a dp unit: key entry, data control, computer operation, programming, systems analysis, programming/analysis, supervision, and management. (These job redesign projects begin this year under a government grant. Similar projects will be undertaken in private industry as funds become available.)

We originally sought to define a survey instrument tailored to the dp field. After two months of evaluating various instruments we decided to use, instead, the Job Diagnostic Survey (JDS) developed by Oldham and Hackman, for two principal reasons:

1. The Hackman/Oldham instrument is conceptually sound. Its validity and reliability have been substantiated in studies of more than 6,000 subjects on more than 500 different jobs in more than 50 different organizations.

2. A major objective is to compare our results with prior studies of

personnel in other professions. Our hypothesis on the difference between dp professionals and other personnel could be tested if we used the JDS.

We expanded the survey questionnaire to include other elements: employee perceptions on relative importance of problems relating to maintenance, realistic work schedules, access to the computer, access to supervisors and access to others (such as users or personnel in other departments whose work affected ours). Also added to the survey instrument was a section on the relative importance of eight categories of compensation.

The resulting Job Diagnostic Survey contains 94 questions and produces information on 45 variables. The survey is administered individually, in approximately 30 minutes.

Most survey questions ask participants to record their response on a scale of one through seven, as in the example below.

All survey results were analyzed with the computer packages for Analysis of Variance (ANOVA) and SPSS (Statistical Processing for the Social Sciences). ❁

accountable for the outcomes of his efforts.

3. *Knowledge of results.* He must be able to determine, on some fairly regular basis, whether the outcomes of his work are satisfactory.

If these conditions exist, a person "tends to feel very good about himself when he performs well." Those good feelings motivate him to try to continue to do well. This is what the behavioral scientists mean by "internal motivation," as opposed to external motivation factors, such as incentive pay or compliments from the boss.

The relationships between the three psychological states listed above and the on-the-job outcomes is illustrated in Fig. 1. When all three are high, then internal work motivation, job satisfaction and work quality are high, and absenteeism and turnover are low.

Data processing employees, according to our results, feel they experience about the same level of meaningfulness from their jobs as do other professionals, but have lower perceptions of the degree of responsibility and knowledge of results. (See Table 2.) The poor ratings on "knowledge of results" stems directly from another category we tested, "feedback from supervision," since feedback from the job itself is about the same for our industry as for others. It appears that our supervisors are not doing anywhere near as good a job as their peers in other professions in providing feedback to employees. (See Fig. 2). This is an area where immediate improvement is possible.

Also, using the model, a single index can be computed which characterizes a job's motivating potential. That index is called the "motivating potential score," and can be used to compare dp jobs with others. The meaningfulness of this index can be illustrated by showing its relationship to things like absenteeism and job performance, as in Fig. 3.

The right hand side of the model (Fig. 1, again) pictures the "personal outcome" from an individual's job. However, the Job Diagnostic Survey (JDS) used with the model does not measure actual work outcomes: productivity, employee perceptions of their productivity, turnover, or absenteeism. Instead, employees report directly how satisfied (or dissatisfied) they are with various aspects of their job. Table 3 provides those results. It indicates that dp professionals generally are satisfied. However, although their general satis-

Psychological State	Data Processing Professionals			Other Professionals
	Analysts	Prog./Analysts	Programmers	
Experienced meaningfulness	5.56	5.49	5.23	5.40
Experienced responsibility	5.31	5.48	5.13	5.75
Knowledge of results	4.59	4.42	4.55	5.00

Table 2. In measures expressing how meaningful they feel their jobs are, or how responsible they feel for the outcome of those jobs, dp professionals—especially analysts and programmer/analysts—are not far different from other professionals. In terms of feedback on the results of their work, however, dp employees rate their jobs lower than other professionals do; their supervisors may be at fault for that. (Note that the ratings are **derived** from those in Table 1. Scale: 1 to 7.)

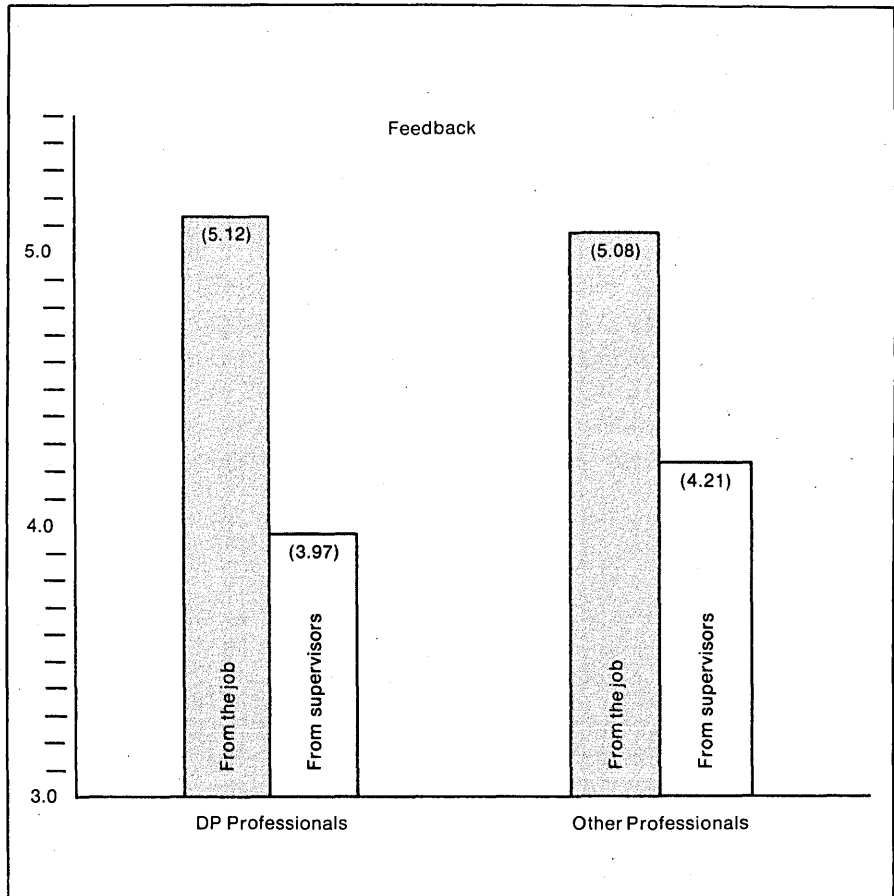

Fig. 2. Data processing professionals say they receive most of their feedback on their performance from the job itself, as do other professionals. But the amount of feedback dp employees feel they get from their supervisors is substantially lower than that seen by other professionals—an obvious place for improvement. (Survey responses are given on a scale of 1 to 7.)

fraction is higher than that of other professionals, they are less satisfied with supervision.

The JDS proved to be an especially good discriminator. One organization surveyed was not "healthy," in behavioral terms. All others were. In fact we attempted to survey only organizations whose working environment was healthy, because we wanted to build "norms"; in the past our profession has been without benchmarks in the behavioral areas. The unhealthy organization was significantly below the norms on most of the core job dimensions. With the information from the model we have a substantive basis for beginning the job redesign process in that organization.

GROWTH NEED VS. SOCIAL NEED

We expect that people who have a high need for personal growth and development will respond more positively to a job high in motivating potential than people with low growth need strength will.

Obviously, not everyone is able to become internally motivated—even when the motivating potential of the job is quite high. Behavioral research has shown that the psychological needs of people determine who can (and who cannot) become internally motivated at work. Some people have strong need for personal accomplishment—for learning and developing beyond where they are now, for being stimulated and challenged, and so on. These people are high in "growth need."

The need for growth is quite high for dp professionals, compared to other professionals and to other job categories. Table 4 shows this effect. This outcome has little surprise for managers accustomed to insistence by their staff that they be provided training, be allowed to attend conferences and seminars, etc. (A frequent result of behavioral research is that intuitive beliefs are substantiated. Survey data on growth need is a good example.)

However, the key reason for computing growth need is to compare it with the job's potential to fulfill that need. A job low in motivating potential will frustrate a person with high need for growth. It is a perfect example of the old cliché of a round peg in a square hole.

The motivating potential score shown in the right column of Table 4 enables a comparison of the job potential to the employee growth need.

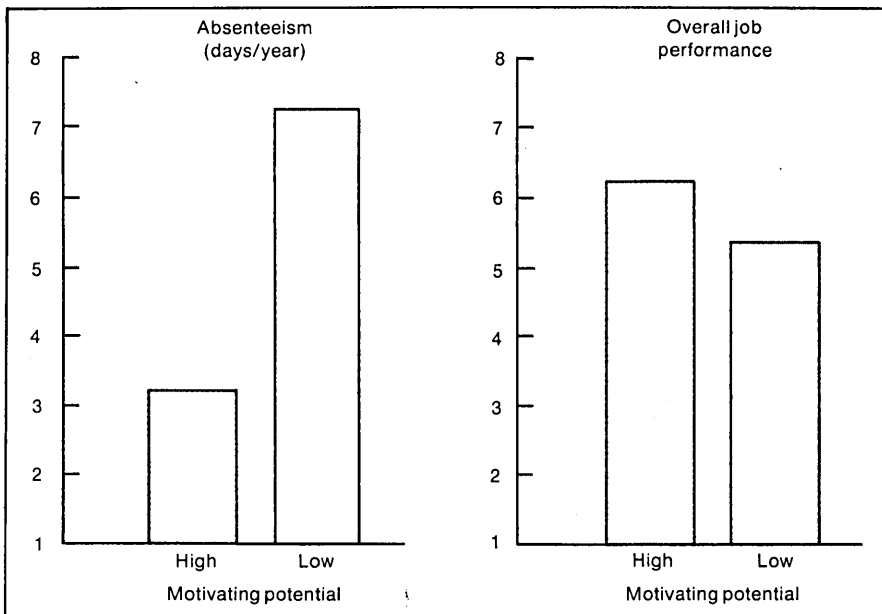

Fig. 3. The motivating potential of various jobs can be calculated from the results of the Job Diagnostic Survey, and the index proves to be very well related to things like absenteeism. The results above are from the Hackman/Oldham study of more than 1,000 employees working on about 100 jobs. (The job performance is as rated by supervisors on a 1 to 7 scale.)

Job Category	Growth Need	Motivating Potential
Dp professions	6.02	157.5
Other professions	5.59	153.7
Sales	5.70	146.0
Service	5.38	151.7
Managerial	5.30	155.9
Clerical	4.95	105.9
Machine trades	4.82	135.8
Bench work	4.88	109.8
Processing	4.57	105.1
Structural work	4.54	140.6

Table 4. Putting an employee with high growth need into a job with high motivating potential leads to a high quality performance and to low absenteeism and turnover. Trying to put an employee with low growth need in such a job, such as the structural worker in this table, risks overstretching the individual.

Fortunately, there is a good match in what dp jobs have to offer and what dp employees need. (The scale for growth need is again 1 to 7; the "motivating potential" scores are derived numbers and are not relative to any scale.)

Hackman's and Oldham's survey results shown include an example of the imbalance of growth need and motivating potential. Notice that the lowest growth need is for structural work. On the other hand, the motivating potential for that field is near the midpoint for all jobs reported in the table. Thus, jobs in that industry have a motivating

potential above the growth needs of the workers.

The dp field provides some better matches. Both the dp individual's growth need and the dp job's motivating potential score are high—the highest in the table. (Unfortunately, our research indicates that such a balance is not so prevalent among the other jobs in the

data processing organization. We'll report on that in later articles.)

Although the average for all organizations in our study showed a high positive correlation between growth need and motivating potential, this was not always the case for individual organizations. For example, the organization with the next to the highest growth need in our survey was the lowest in motivation. In contrast, another organization with the lowest growth need was highest in motivation. Now that they are aware of this disparity, these organizations can analyze their jobs to reduce the inequity.

The most surprising result of the survey was the measurement of the variable labeled "social need." Survey questions related to this variable determine an individual's need to interact with others. The average score on this variable for all other professionals was 5.48. For all data processing professionals in our survey, the score is 4.19. (See Fig. 4.) However, for five organizations the average was only 2.23! So, while some professions attract people who have a high propensity for—and reinforcement from—interaction with others, our profession does not appear to exhibit this characteristic.

The implications are significant. Programmers and analysts have increasingly been grouped into teams in anticipation that productivity will be increased. The chief programmer team concept has been widely publicized and advocated. Some have suggested that it is the social interaction of the team that has produced whatever productivity benefits resulted from the programmer team approach. If our study is representative, it mandates caution in accepting such views.

What does this survey statistic mean to a manager of dp professionals? The lack of need for social interaction does not mean that teams should not be utilized. It simply indicates that dp professionals are not actively seeking a team experience. (Managers of other parts of the company will find their employees eager to interact, and a team approach is a natural organization to facilitate such interaction.) This conclusion is supported by data from Table 3. Dp professionals in the survey organizations were satisfied with their co-workers. In other words, they were getting the interaction they needed—as long as it was not overdone.

Our industry, like others, has a number of experientially derived theorems that have not previously been validated by statistical studies. For

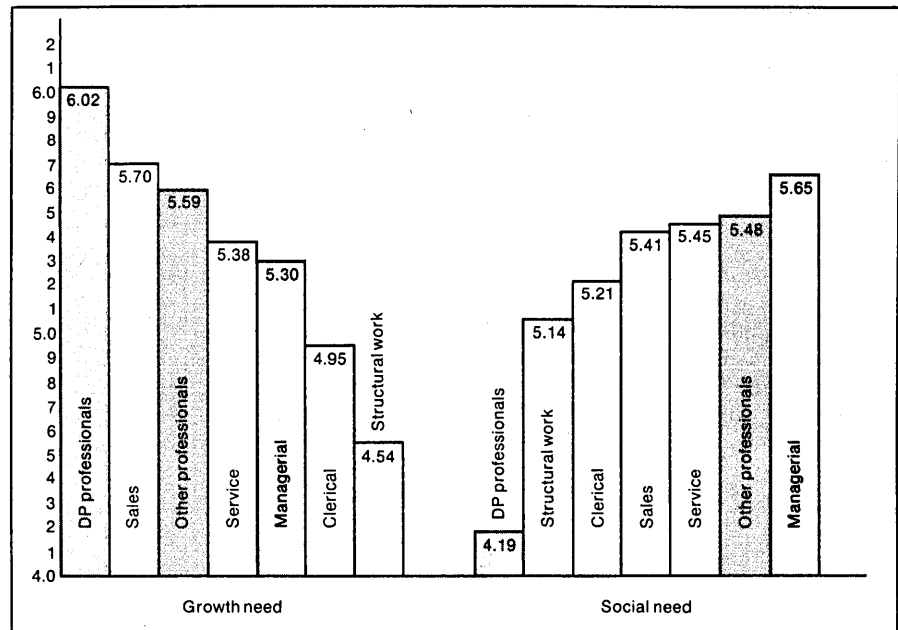

Fig. 4. Are programmers, analysts, and programmer/analysts "loners"? The results seem to confirm that. They are also unusual in their need for individual growth. (As before, responses are on a scale of 1 to 7.)

Measures of Satisfaction	Data Processing Professionals			Other Professionals
	Analysts	Prog./Analysts	Programmers	
General satisfaction	5.10	5.37	5.30	4.88
Satisfaction with co-workers	5.01	5.22	4.96	5.48
Satisfaction with supervision	4.64	4.60	4.60	4.89

Table 3. The results show that dp professionals are fairly satisfied with their jobs in general, somewhat less satisfied with co-workers, and even less satisfied with their supervisors. (Scale: 1 to 7.)

example, how often have you heard the comment that programmers are "loners"?

The growth need section of our study lent authenticity to one of those theorems. Here is another case. Perhaps the theorem is best expressed by Gerald Weinberg in his widely quoted *Psychology of Computer Programming* (Van Nostrand Reinhold Co., N.Y., 1971). "If asked, most programmers probably say they preferred to work alone in a place where they wouldn't be disturbed by

other people."

However, we interpret the survey results on social need as follows: management does not need to reduce emphasis on the project team, it just needs to control the frequency and duration of team meetings. Consider the oft cited guideline that structured walkthroughs should be limited to two hours. You don't find similar guidelines in the literature on management meetings! (The social need strength for managers in the Hackman/Oldham

We are emulating the industrial engineers of the 1940s, chipping away at each job on the assembly line, splintering it into the ultimate specialization.

surveys was 5.65. Managers could be in meetings all day—and love it.) The structured walkthrough guideline was empirically derived, probably by judging the increasing level of impatience by analysts and programmers when a meeting dragged on.

Also, a low social need may indicate the need for additional training on supervisory techniques when dp professionals are promoted to management positions.

WHAT IT MEANS

Although we have barely begun the in-depth analysis of our data base, some tentative propositions are:

1. *Dp professionals have some unique differences from the general population.* They have substantially higher growth need strength than any of the job categories surveyed by Hackman and Oldham. This is true of analysts, programmer/analysts, and programmers. Also, they have the lowest social need strength among professionals—significantly lower than others.

2. *A good job match is possible.* For the survey firms—intentionally selected because they are healthy—the motivating potential of the jobs match the growth needs of dp professionals.

3. *Supervisory feedback to employees can be improved.* Employees in the survey firms are generally satisfied with co-workers and with supervisors. Nevertheless, they believe that feedback from supervision should be improved. They rate this category lower than do their counterparts in the other professions.

4. *An appropriate conceptual model exists.* The Hackman/Oldham model is applicable to the computer field. Our analysis substantiated that of the original researchers, with comparable statistical reliability and validity. The conceptual model (in Fig. 1) is useful for management in our field to analyze individual motivation patterns, and the Job Diagnostic Survey is useful to gather data to determine satisfaction levels and work outcomes.

5. *Job redesign has potential.* Studies of other industries show that job redesign can increase satisfaction and productivity. With the norms resulting from our study, managers in the computer field have the basis for determining which jobs have potential for improvement.

Productivity consists of two parts—improved techniques and increased motivation to utilize those techniques. An enormous amount of time and energy has gone into the first part, technique improvement. Why has

the second part, motivation, been given so little attention?

Is it the qualitative nature of that part? Are we so oriented to the analysis of the quantitative part of the job that we willfully ignore the harder to measure aspects of employee motivation?

Or is it the fact that we are “systematic” people who deal in practicalities. We want something we can touch or see. “Lines of code per hour” is a measurement that can be substantiated. Degree of motivation cannot be seen, felt, tasted or smelled—but it exists.

We are emulating the industrial engineers of the 1940s, who kept chipping away at each job on the auto assembly line until it was splintered into the ultimate level of specialization. We seem to be concentrating just as fervently on fragmenting the jobs of analysis and programming. The chief programmer team concept is the latest in the long list of moves for enhancing specialization. The analysis/programming task now is fragmented into the elements performed by the chief programmer, the moderator, the librarian, the recorder, etc. Perhaps jobs should be *enlarged* in scope, rather than reduced.

If we devote equal time to the analysis of motivation and the ingredients of job satisfaction, this alone may increase productivity. However, productivity increase is the wrong reason for initiating such a study. Shouldn't a supervisor gain as much satisfaction from helping employees achieve fulfillment as from meeting cost/schedule objectives?

Fortunately, researchers like Hackman and Oldham have proved in other industries that productivity can be increased by a better matching of jobs with individuals.

We already have a data base rich with information for further analysis. For example, our data on problem areas and on compensation preferences presently is being analyzed for another DATAMATION article.

During the next year we will be increasing our data base to include more than 2,000 professionals, to ensure a representative set of “norms.” At the same time, we will be conducting job redesign studies, to better understand the factors which produce job satisfaction.

Our profession has been very progressive in developing new product related techniques. Let's hope that progressive attitude will now extend to better utilization of the behavioral sciences. ❁

J. DANIEL COUGER



Dr. Couger is professor of computer and management science in the Univ. of Colorado's College of Business. Before joining the cu

faculty in 1965, he spent 13 years in industry. He has more than 20 years experience in computing, being one of the first to enter the field.

As an example of his diverse activities, Dr. Couger has testified as an expert witness before the Royal Investigation Committee of the Swedish Parliament, served as a curriculum consultant to more than 30 U.S. universities and colleges, and lectured in 45 countries on the subject of computer-based management information systems. He has served as a consultant to more than 30 organizations, including Dow Chemical, IBM, and Hewlett-Packard.

Last year he was selected as DPMA's U.S. Computer Science Man-of-the-Year. He is listed in “Who's Who in America,” “Who's Who in Computing,” and “Outstanding Educators of America.”

ROBERT A. ZAWACKI

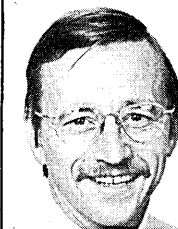

Dr. Zawacki is an associate professor of management and organizational behavior at the Univ. of Colorado, where he teaches personnel management and

organization behavior courses. Before joining the cu faculty, for nine years he was on the faculty of the Air Force Academy where he held a variety of positions such as director of the Academy Research Div., a cadet professional counselor, chief of cadet personnel, and as a faculty member in the department of behavioral sciences.

His consulting experience has included work for businesses, hospitals, government agencies, and academic institutions.

**Work
Itself**

Achievement

Advancement

Recognition

**Possibility
For Growth**

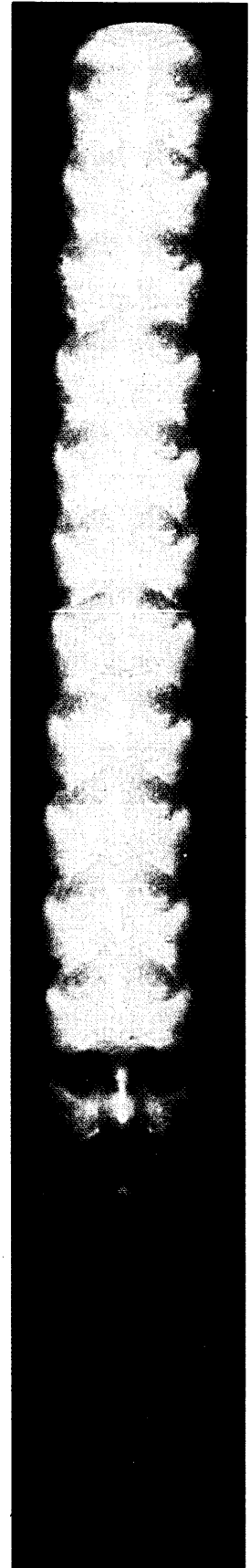
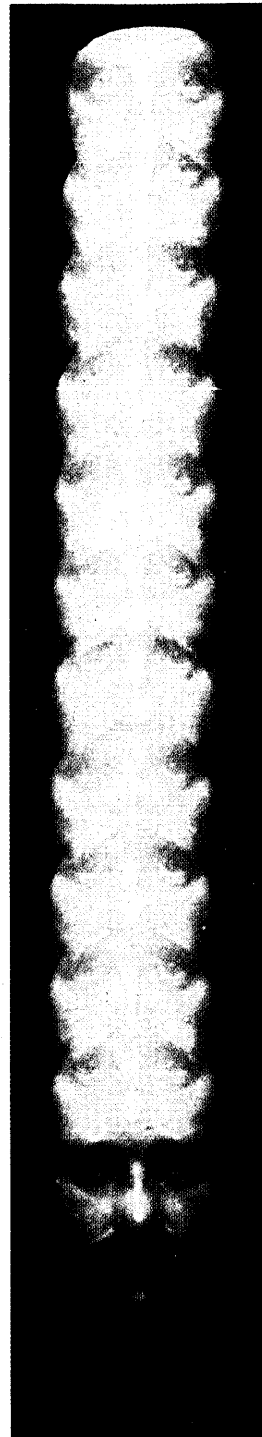
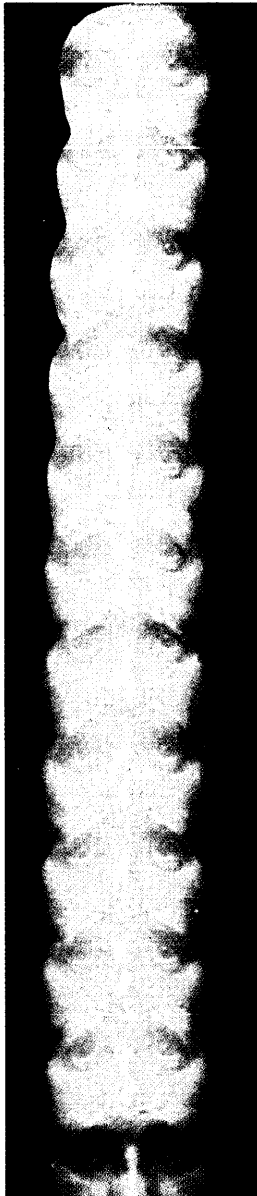
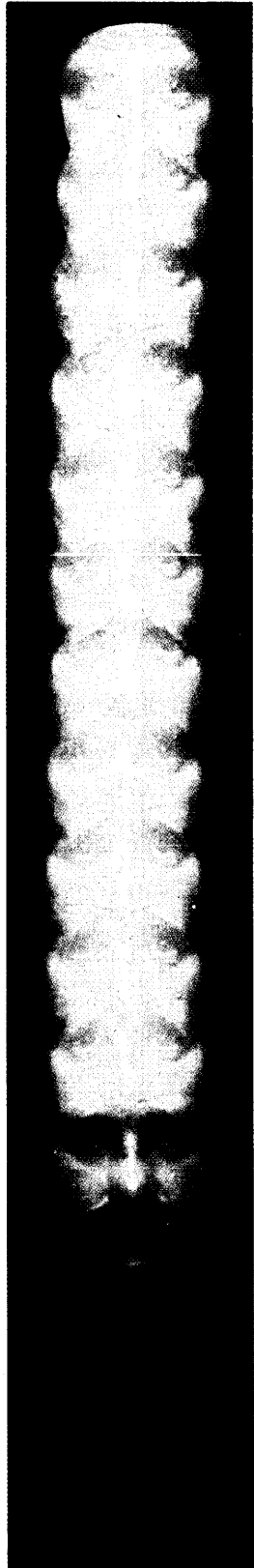
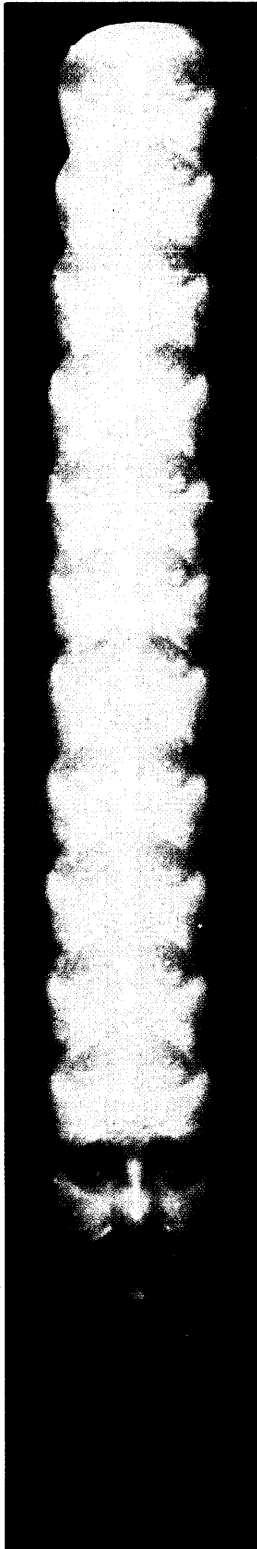

WHO IS THE DP PROFESSIONAL?

by Jac Fitz-enz

The average programmer is excessively independent—sometimes to a point of mild paranoia. He is often eccentric, slightly neurotic, and he borders upon a limited schizophrenia.

D.H. Brandon

Statements such as this one by D.H. Brandon, president of Brandon Consulting Group, Inc. of New York City, and a long time lecturer on data processing management topics, have served to stimulate investigations into the nature of the data processing professional.

A legend has developed around the mysterious creature who inhabits a large, air-conditioned room and spends his time conversing with a big, black box. Some people claim he is a genius, too bright for the common person to comprehend. Others say he is a recluse who is only capable of communicating with a box. Most accounts of his personality and behavior are inferences built on top of speculations. Solid data concerning his nature is hard to find.

Many managers and researchers have formed the opinion that programmers, as an occupational group, are rather unusual individuals compared with people who select other careers. They supposedly are willing to work in isolation, wish to avoid interaction and possible confrontation with others including direct supervisors, prefer minimal structure and routine, and are motivated primarily by achievement rather than external rewards, status, or approval of others.

In the data processing environment, so much happens so fast that training data processing personnel to be better managers usually takes a priority far behind technological concerns. If we will but find the time to teach our managers something about why people behave as they do, to train them in better communication methods and to show

them how to structure work so that personal drives can be unshackled, we could obtain an increase in productivity far surpassing what the latest piece of hardware or software can give us.

We conducted research in a dozen companies in the western United States during the latter part of 1977 to attempt to find out something about the dp pro's motivation to work and his desires for communicating with the organization that employs him. Data was gathered using a survey questionnaire designed and pretested for the specific project. Some 1,500 subjects in several industries, occupations, and job levels responded to the questionnaire.

Any study of motivation must proceed from the premise that motivation is an inherent trait. We talk about motivating employees. This is not possible. In reality, all a manager can do is provide a setting which allows an individual to satisfy his internal drives. As we reviewed our data it became apparent that this is a personality truism.

During the 1960s, Fred Herzberg directed a motivational research project which led to his now popular two-factor theory of motivation. It claims that basic motivational elements can be split into two categories labeled "hygiènes" or "dissatisfiers" and "motivators" or "satisfiers." Herzberg identified eleven hygiènes: Salary, Possibility for Growth, Interpersonal Relations with Subordinates, Status, Interpersonal Relations with Superiors, Interpersonal Relations with Peers, Technical Supervision, Company Policy and Procedures, Working Conditions, Noninterference with Personal Life, and Job Security. These, he said, are aspects of the job which must be maintained at an essentially positive level before motivation can flourish.

His motivators or satisfiers number five: Achievement, Recognition, the Work Itself, Responsibility, and Advancement.

Herzberg's theory has been widely publicized. Because it is currently the most widely referenced theory in industrial training, we chose to correlate our findings with his.

Table 1 is a comparison of Herzberg's rankings with those of our subjects.

There are similarities and differences. Responsibility, which ranked fourth in the Herzberg results, dropped to seventh in our study. When we cut the data by Job Level, a reason for the shift surfaced.

Fig. 1 presents a cross section of the responses from programmer/analysts, project leaders, and managers.

While managers ranked Responsibility first and project leaders (PL's) ranked it fourth, programmer/analysts (P/A's) ranked it ninth. For the P/A's, Responsibility fell far below what are normally considered lower level hygiene factors. Even Personal Life topped Responsibility. This finding brought up some tantalizing questions.

If P/A's do not want the responsibility that goes with their work, it may suggest that they are coping out. Does it mean that they are approaching their jobs from a purely self-centered direction? Does it mean that they do not want to be accountable for their results? Of the first five Herzberg factors, four can be viewed as essentially ego-centered. Responsibility is the only factor Herzberg found to have an organizational orientation. Achievement, Recognition, Advancement, and the content of the Work Itself all supply the individual with personal satisfaction. Although having necessary responsibility to carry out the job is also ego-reinforcing, it has the corresponding element of obligation to the organization. Did the respondents rank it low because they took it as a given? Probably not. If that were so, it would follow that PL's and managers who rose from a programmer level should also take it for granted.

Men chose work itself as the greatest motivator. Women chose it fifth.

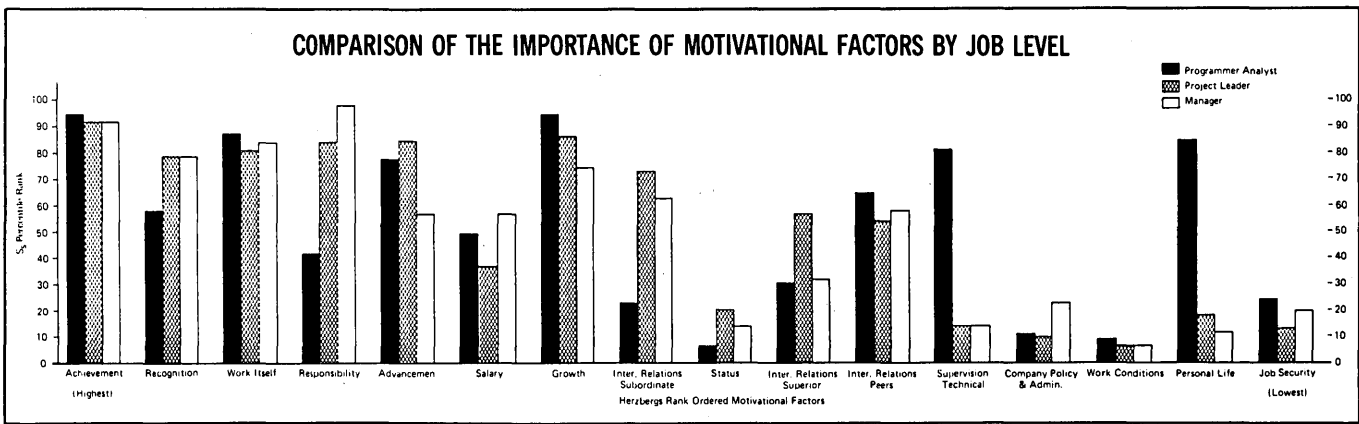

Fig. 1. Rankings of motivational factors are compared for programmer/analysts, project leaders, and managers.

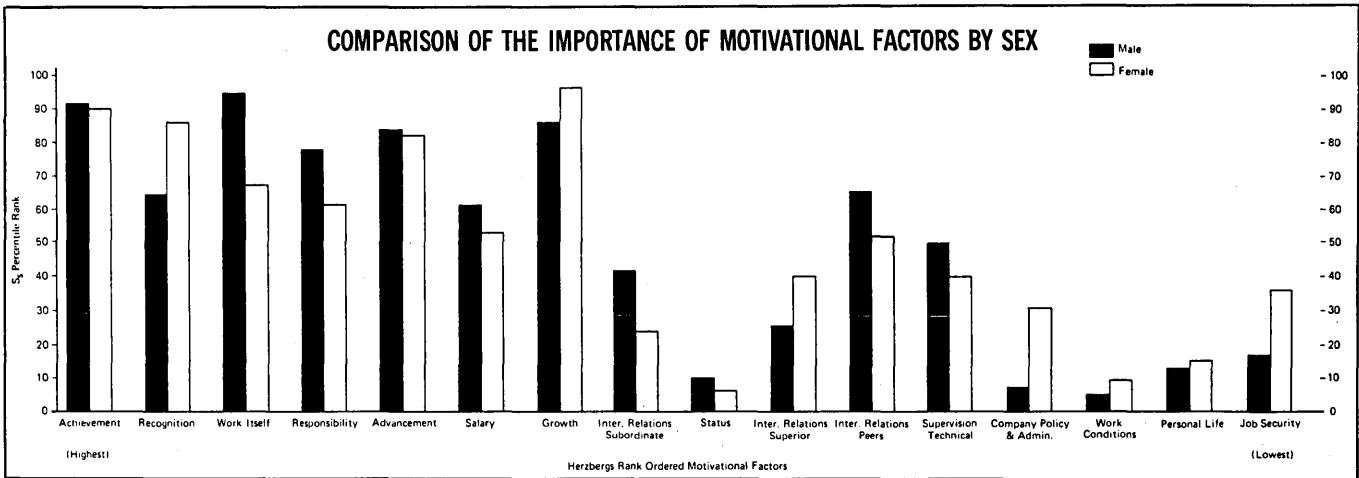

Fig. 2. The rankings of motivational factors are compared by sex.

RANK ORDER COMPARISON OF FIRST LEVEL FACTORS	
Herzberg Results	Study Results
1. Achievement	1. Achievement
2. Recognition	2. Possibility for growth
3. Work itself	3. Work itself
4. Responsibility	4. Recognition
5. Advancement	5. Advancement
6. Salary	6. Supervision, technical
7. Possibility for growth	7. Responsibility
8. Interpersonal relations, subordinate	8. Interpersonal relations, peers
9. Status	9. Interpersonal relations, subordinate
10. Interpersonal relations, superior	10. Salary
11. Interpersonal relations, peers	11. Personal life
12. Supervision, technical	12. Interpersonal relations, superior
13. Company policy & admin.	13. Job security
14. Working conditions	14. Status
15. Personal life	15. Company policy & admin.
16. Job security	16. Working conditions

Table 1. Results of the 1960s Fred Herzberg study are compared with those of the author's study.

GENERATION GAP

Subsequent to the survey, follow-up interviews were held with a number of programmers to elicit a reason for this difference. The interviews were not very illuminating. No seemingly sensible alternatives to the self-centered theory were given. As a result, we are stuck with one of two speculations. First, indeed the generation gap does exist. Today's younger workers may not value Responsibility the same way that Herzberg's subjects in the 1960s did. The second possibility is equally provocative. There may be something in the way the programmer's job is structured that robs him of a sense of responsibility and hence a desire for it. If that is the case, dp managers have a major problem on their hands. At this time, the finding leaves us perplexed and calls for further investigation.

When the data was subdivided by sex, as shown in Fig. 2, other peculiarities appeared.

Men chose the Work Itself as the greatest motivator and placed it in the 93rd percentile. Women chose it fifth in the 68th percentile. Conversely, the women placed Recognition third in the

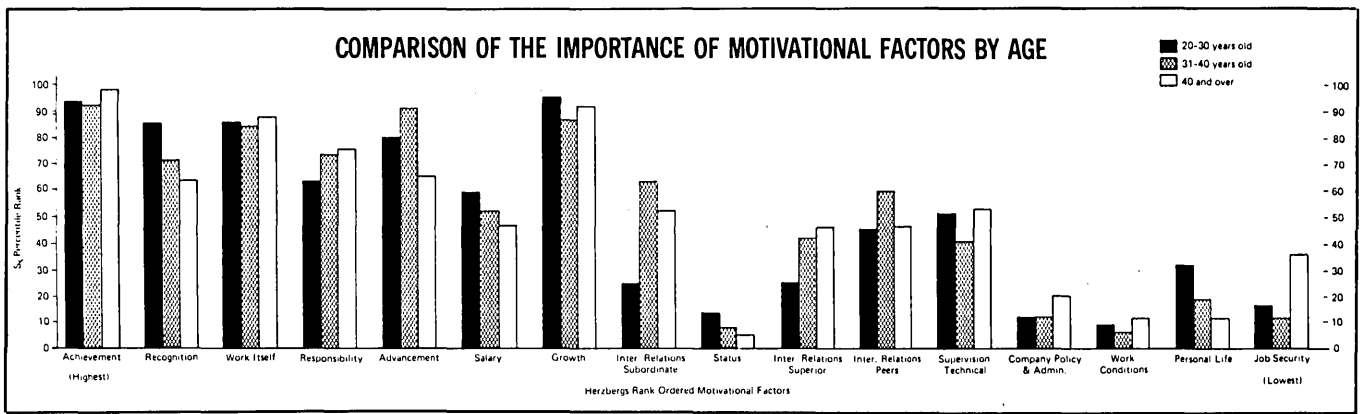

Fig. 3. The rankings of motivational factors are compared by age.

86th percentile; while men ranked it seventh in the 65th percentile.

Finally, the age breakdown in Fig. 3 brings out an interesting point. As age increased, the importance of Salary decreased almost in a straight line from 59th to 52nd to 46th percentile, and from seventh to ninth to eleventh in rank order. This result supports another popular conception of human motivation. Abraham Maslow proposed a theory in the '50s which placed needs in a hierarchy from basic survival through safety, social, and ego needs, to complete human fulfillment which he labeled

self-actualization. He claimed that as one level of need is satisfied it is supplanted by a higher level need. In this case, as individuals aged and presumably made more money, thus satisfying survival and safety needs, salary became less motivating while need for personal growth and interpersonal relationships strengthened.

There are a number of other interesting variances overall from Herzberg's theory. The more we dissect the data, the more we can see that while there are basic similarities in the motivational patterns of people, individual

differences do pertain. It is apparent that, to some degree, dp professionals have motivational drives which do not fully correspond to other occupational groups. The implication for management is that in order to have motivated employees, supervisors must understand and bear with individual needs. The monolithic notion that "people are all alike" simply is not supportable.

We also surveyed our subjects' attitudes toward organizational communication. We asked them to rank order, in terms of importance to them, organizational topics in which they were most interested. We also asked them to choose for each topic the source which they most and least preferred to have deliver the information. Table 2 shows the rank order of interest by job level, sex, and age.

Without exception, Job Performance and Career Opportunity information have been ranked first and second, well above all other topics. Personnel programs, such as salary and benefit information, usually rank third, closely followed by Company Profit performance and Changes in the work or organization of the unit. The remaining topics are of considerably less interest.

In this instance, overall changes ranked third, slightly ahead of Personnel information. Our guess is that since most dp departments are rapidly growing and changing organizations, this topic is of unusually high interest. In more stable units such as Accounting or Purchasing, change is not as prevalent. Profit information dropped from fourth to fifth in the ranking, and the degree of interest dropped off quite sharply.

Given the above, we would expect that the greatest effort would be being made to communicate information on performance and opportunity. Yet all evidence shows undeniably that organizations do their poorest jobs on these topics. A review of the literature over the past 20 years consistently shows cor-

PERSONAL INTEREST OPTIONS								
Rank ordered Interests	Job Level			Sex		Age		
	Percentile Rank		Manager	Percentile Rank		Percentile Rank		
	Programmer/ Analyst	Project Leader		Male	Female	20-30	31-40	40+
1. Current job performance	90	85	92	92	99	95	90	92
2. Future career opportunities	87	89	82	89	94	92	86	78
3. Changes in organization & activities of dept.	63	63	62	62	71	66	57	61
4. Changes in personnel policies	55	53	45	44	46	49	50	61
5. Corporate profit performance	29	26	47	23	24	19	42	37
6. Company operating policies and procedures	24	37	21	15	22	31	29	23
7. General company activities	7	5	6	1	10	9	5	6

Table 2. Personal interest options are ranked by job level, sex, and age group.

We should spend more time helping supervisors become good communicators.

MOST PREFERRED COMMUNICATIONS SOURCE

Source options: A Immediate Supervisor (one level up)
 B Senior DP Executive
 C Senior Executive outside of DP
 D Senior Staff Specialist

Topic	Job Level			Sex		Age		
	Programmer/ Analyst	Project Leader	Manager	Male	Female	20-30	31-40	40+
1. Current job performance	A	A	A	A	A	A	A	A
2. Future career opportunities	B	B	A	B	A	B	B	A
3. Changes in organization & activities of dept.	A	A	A	A	A	A	A	A
4. Changes in personnel policies	A	A	A	A	A	A	A	C
5. Corporate profit performance	C	C	C	C	C	C	C	C
6. Company operating policies and procedures	C	B	A	A	B	A	B	C
7. General company activities	A	A	A	A	A	A	A	A

Table 3. Most-preferred communications sources are ranked by job level, sex, and age group.

porate failure in coming up with a satisfactory performance appraisal system. Career counseling programs have received slightly less attention and no more success. The greatest gains in improving employee attitudes and morale are probably to be found in concentrating our efforts to effectively communicate this information.

The data on communication sources displayed in Table 3 is equally clear-cut.

ON THE SPOT The supervisor is unquestionably the person on the spot. Our early research was based on the assumption that while the immediate supervisor would be looked to for performance evaluation, other sources would be preferred for other topics. This was not and is not the case. Most often the supervisor appears as the most preferred source. Never is he chosen as the least preferred. On four to six topics out of seven, the supervisor is chosen first. The supervisor is better known, usually more trusted, and more

capable of translating and interpreting for the subordinate the probable effect of most information.

Other research has shown that a supervisor has a great deal of influence on the general morale of his subordinates. More than any other individual, and more than other such potent forces as the company itself, the supervisor is the critical element. Hence, it is obvious we should spend more time helping supervisors become good communicators. They are important in both positive and negative situations. First, they are the most sought after communicators when it comes to telling the company story. Second, they can be the deciding force when there is individual or group discomfort.

Again, the opportunity is before us. We can achieve the greatest gains by training supervisors at all levels to communicate better. Conversely, we have the most to lose by continuing to ignore the current deficiency.

Charles Andrew, speaking at a recent conference of Production and

Inventory Control Specialists, said:

"Successful implementation of an edp system has to start with a valid, realistic management theory—a balancing of the operations orientation with some practical thoughts from the behavioralists."

Gerald Weinberg, in his book on the application of psychology to computer programming, goes even further by noting that personality is displayed in everything we do or say. In particular he asserts, it is reflected in programming efforts. Weinberg believes that the personality of the programmer is observable in the manner in which he approaches the task and the product that results from his labor.

Our study attempted to determine some of the needs and communications desires of people in the business of data processing. When applied at this particular point in the rapid evolution of information processing, we feel it has particular significance.

The study has shown that while data processing professionals display some idiosyncracies, they have much in common with other people. A basic knowledge of human behavior can help us perceive and cope with the attitudes, interest, needs, and values of our employees. We must keep in mind that no matter how sophisticated our technology becomes, we will always have to rely on human beings to design, build, sell, install, service, and use it. Efficient and effective performance of these tasks is directly dependent on our ability to understand and manage these people. *

JAC FITZ-ENZ

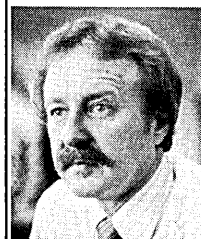

Dr. Fitz-enz is director of industrial relations for Four-Phase Systems, Inc. in Cupertino, California. Prior to this he was vice president of

organization development for Imperial Bank, in Los Angeles. He has published articles on personnel, training, and psychological subjects and has consulted with a variety of organizations. Dr. Fitz-enz received his Ph.D. in communications and industrial relations from the Univ. of Southern California, M.A. from San Francisco State, and B.A. from Notre Dame.

Hazeltine

The Leadership Line
of Economy Terminals

Just Right!

Hazeltine 1400

Clear, crisp window to any system. **Just Right!** for conversational applications where system cost is critical. Our newest, lowest-priced terminal!

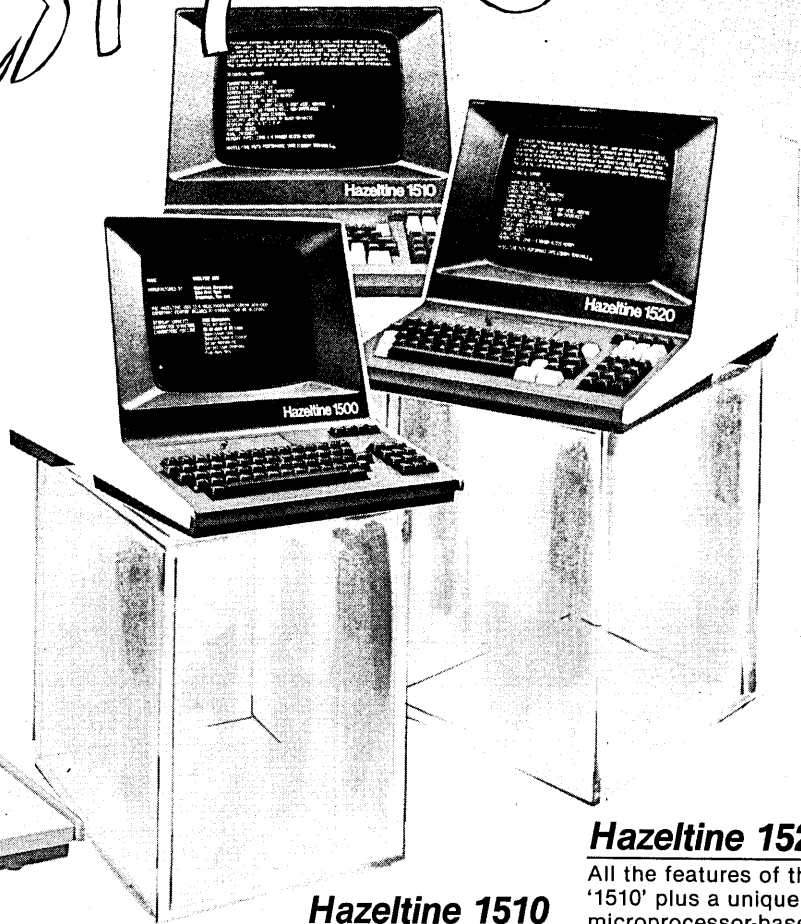

Hazeltine 1500

A superb conversational terminal. **Just Right!** for small business systems, with remarkable clarity of display plus many features normally found in higher-priced terminals!

Hazeltine 1510

All the features of the '1500' plus buffered operation with editing. **Just Right!**

Hazeltine 1520

All the features of the '1510' plus a unique microprocessor-based printer interface. **Just Right!** for local or on-line, buffered parallel or serial printing.



Hazeltine Corporation

Computer Terminal Equipment, Greenlawn, New York 11740 (516) 549-8800 Telex 96-1435
EAST: N.Y. (212) 586-1970 □ CENTRAL: Chicago (312) 986-1414
SOUTH: Atlanta (404) 952-8444 □ WEST: Burlingame (S.F.) (415) 342-6070
ENGLAND: Hazeltine Ltd. 01-948-3111 Telex (851)-928572
GERMANY: Hazeltine GmbH 0611-590748 Telex (841)-416924
FOR WORLDWIDE SALES INFORMATION CALL: (516) 549-8800

Those other behaviorists haven't gone far enough afield in studying the psychology of computer programming.

ANOTHER REPORT FROM THE PSYCH LAB

by Donald Kenney

Prior to now, little or no valid work has been done on the psychological aspects of computer programming. The problem is, not surprisingly, economic. Even using that least expensive of human research subjects, the graduate student, achieving adequate sample sizes is prohibitively expensive. Moreover, the end of the military draft has sharply decreased the number of graduate students available for study. Recognizing this problem, my colleagues and I set out to study the feasibility of investigating the psychology of computer programming using nonhuman (and therefore cheaper) subjects.

It quickly became clear that a modicum of intelligence is required for the process of computer programming. A few simple tests quickly ruled out paramecia, flatworms, fruit flies and most other invertebrates as possible subjects for study. (At least for computer programming—several very interesting experiments are underway in software project management and configuration control using both fruit flies and flatworms.)

For a while we hoped that the social insects—ants, bees, termites—might make suitable subjects. We were eventually forced to give up on this by our discovery (which we termed the Civil Service Effect) that the apparent

structure of such insect colonies consists almost entirely of individuals working at cross-purposes and that there is no discernible method to input either data or direction into the insect society.

A few experiments were made with cephalopod mollusks (octopi), with somewhat ambiguous results. Their habit of hiding in a cloud of ink whenever anything went wrong, plus their general ill nature (they bite) and the highly corrosive characteristics of their salt water environment proved to be more than we could cope with. This phase of the experiment was terminated when our prize subject—a four foot specimen of *Argonauta argo* named Millicent—removed the author's

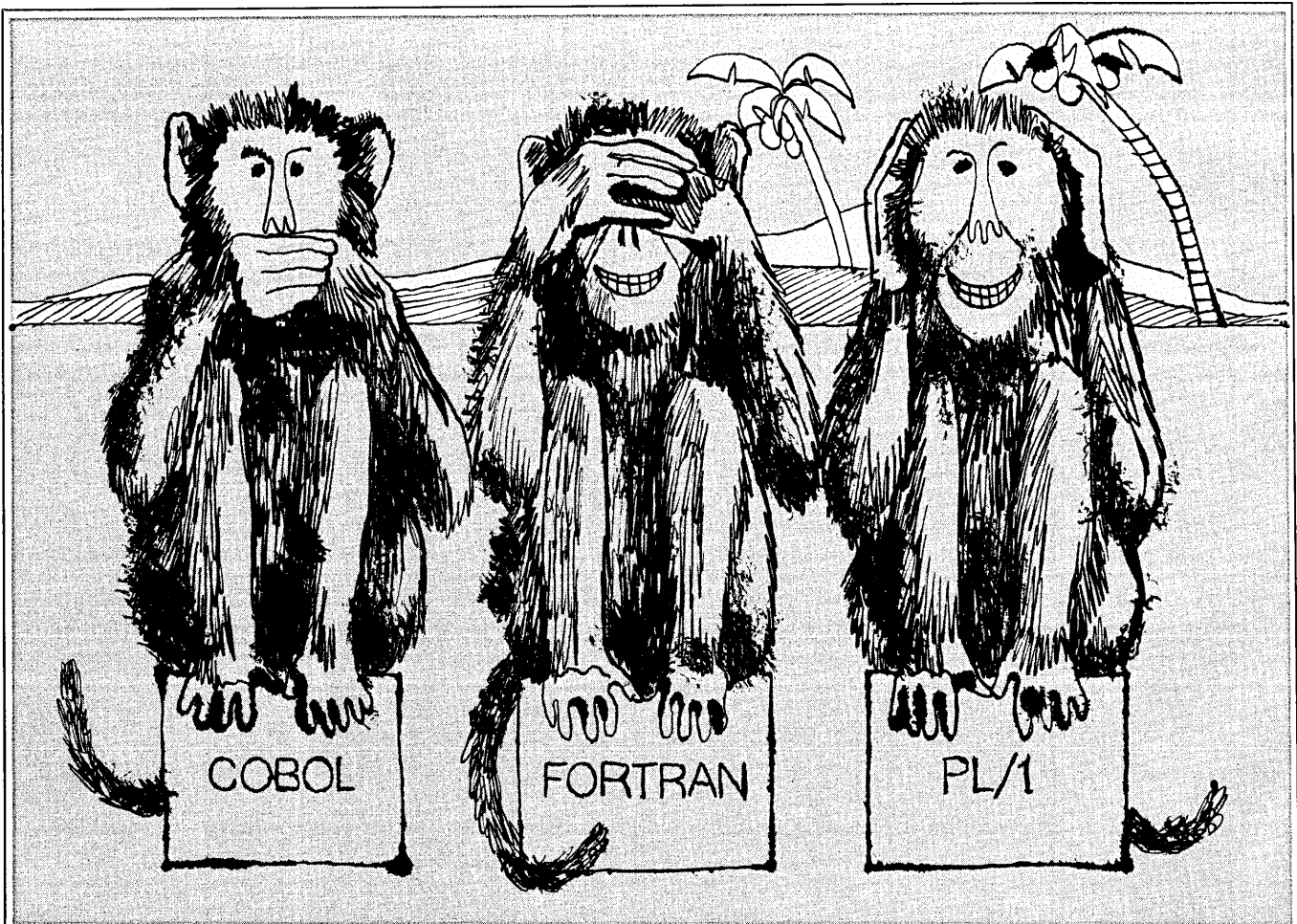

DP Dialogue

Notes and observations from IBM that may prove of interest to data processing professionals



Here, telemetry devices transmit experimental data to a mobile laboratory. Similar advanced technology is reflected in Deere's worldwide data base of thousands of components, letting engineers utilize existing parts when developing new products.

At John Deere, No One Reinvents the Wheel

Engineers at John Deere don't spend time reinventing the wheel or designing new hydraulic pumps or valves when existing ones will do the job. At their fingertips are data on all Deere parts and

design parameters on commonly used parts and components. This multinational manufacturer of machines for farm and construction has created a multilingual data base called WISE — Worldwide

Information System for Engineering.

"If an engineer in, say, our Mannheim, Germany plant needs a hydraulic cylinder design," says Gordon Millar, vice president of engineering, "he can use an online terminal to call up complete descriptions of similar cylinders already in use in Deere worldwide. He will probably find a design he can use with little or no change.

In Four Languages

"Since WISE is literally a worldwide system, it cuts across barriers of language, distance and culture," adds G.T. Underwood, manager of Deere's corporate engineering standards department. "Our master list of terminology is already in four languages: English, French, German and Spanish and all dimensions are in metric and English. WISE has greatly enhanced our worldwide standardization efforts. Also our engineers around the world can readily access design specifications, application information, cost, vendor lists and the like."

"WISE was the first element of a corporate parts data base," says Larry Moore, administrator of engineering information in Deere's corporate engineering standards department. "Now it has links to other business systems in the company, supporting applications in such areas as service parts, warranty service, and parts catalog publications.

"Currently there are about 50 CRT (cathode ray tube) and 100 computer output microfiche display stations in 20 design centers in the U.S., Europe, Argentina, Australia and South Africa. CRT's access our IBM System/370 complex in Moline through the same telephone lines that carry our voice communication.

"The engineer can search the data base by attribute, such as the size or pressure rating of a hydraulic cylinder. In effect, he describes a desired part to the system and automatically receives back a listing of all Deere parts which fit the description.

"We're achieving better parts commonality, and better, faster communication among engineering and manufacturing groups all around the world, by means of the computer."

The CADAM® System: Interactive Graphics for Design Engineers

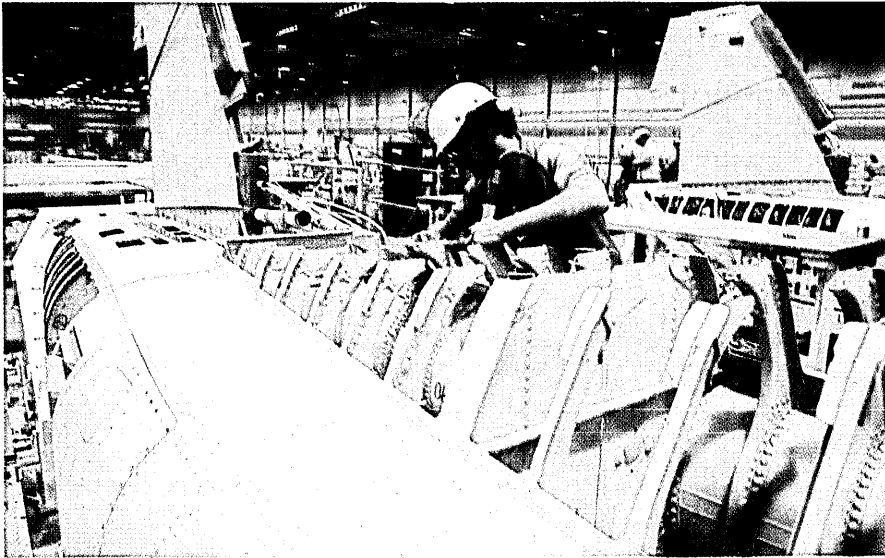

Engineers at Northrop Corp. use computer graphics to speed the structural design of high-performance jet aircraft.

Producing a modern aircraft can require more mechanical drawings than rivets.

Traditionally, engineers sketch, then draftsmen draft. Then engineers discover needed changes or improvements, and draftsmen draft some more. A lot more. Move a stiffener or bracket, say, two inches to the left, and a chain reaction of changes ripples through the entire set of drawings.

But now the computer has opened up a new way to meet design engineering needs with speed and reliability for a broad range of products, from high-performance aircraft to complex integrated circuits. The CADAM (Computer-Graphics Augmented Design and Manufacturing) system, a set of interactive programs available from IBM, allows the designer to sketch directly on the screen of a graphic terminal. He defines lines and contours by pressing keys and positioning a light pen, and the computer displays what he has expressed.

Curve fitting, or reducing the design to a set of control equations, is completed iteratively at the terminal, eliminating coding, card punching, and repeated computer batch runs. Then the CADAM system converts the preliminary design to a dimensioned drawing with auxiliary views.

If something needs fixing — if, for example, the dimensioned drawing reveals a problem of component or subassembly compatibility — the pieces can be moved around with the light pen and the CADAM system will revise all of the affected drawings. Automatically.

The CADAM system encourages doodling, an important source of design inspiration. The user can translate or rotate any graphic element. Or change its scale. Or stack parts, separate them, or watch moving parts move.

The CADAM system stores the design as it is developed, displays any element on demand, then generates the final detailed drawings. It supports complete design of the part, including structural members and such elements as ribs, stiffeners, lightening holes and fasteners. Once a design is stored in the CADAM system, analysis programs can calculate its weight or determine its structural properties. Any frequently used design element or drawing symbol can be stored and reproduced automatically wherever it is needed.

As its name implies, the CADAM system includes a direct link to manufacturing. It can generate a "part program" (path of travel) for the cutter of an automatic machine tool.

The CADAM system has cut drafting manhours drastically for engineering departments — by as much as 90 percent or more on a few special tasks. It helps prevent and correct errors and improves the quality of the engineering product. One user's experience is described below.

Productivity Up

Northrop Corporation is one of the world's largest manufacturers of high performance jet aircraft. Today, Northrop engineers design complex aircraft parts with the CADAM system in a fraction of the time they once spent working at drafting boards.

Says Northrop's Aaron Feder: "In addition to the time savings, we can identify improvements in design quality. Because changes are so easy to make at a terminal, we can keep up with changes traditionally required during the design development of an aircraft part and still release the drawing on time." Feder is manager of technical computer graphics at Northrop's Aircraft Division in Hawthorne, California.

"Before installing the CADAM system," Feder points out, "we ran a number of carefully controlled tests. When we saw productivity gains ranging from four to one to as high as 17 to one, for changes to a drawing, we saw the potential and decided to adopt it.

"We compared the manhours required to prepare several types of drawings using the CADAM system with the time requirements using our established manual systems.

"This involved a broad sampling of different types of drawings, including layouts, structural and electrical drawings. We saw productivity gains of four to one or better on every one of 14 test problems. Even though productivity is lower in the hectic, day-to-day development design world, the CADAM system has still proven cost-effective.

"Once a tentative design is in the computer," Feder adds, "we can run engineering analyses: calculating weights and determining the capabilities of the design aircraft and the dynamic behavior of its structure.

"The data required for this kind of analysis is already in our System/370, as a byproduct of the graphic design effort. That means another major savings in manhours, the elimination of a significant source of error, and the assurance that all departments are working from the same data."

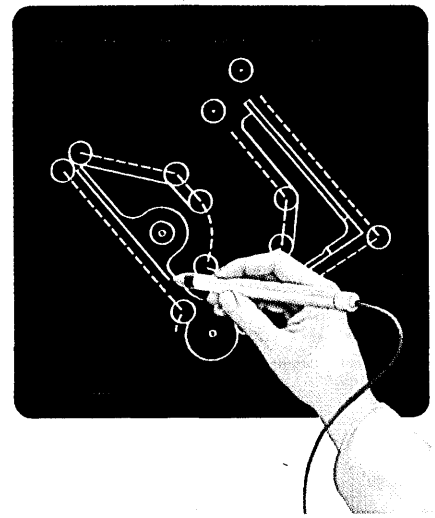

The CADAM system converts freehand sketches, made directly on the CRT screen with a light pen, into fully defined and dimensioned graphics.

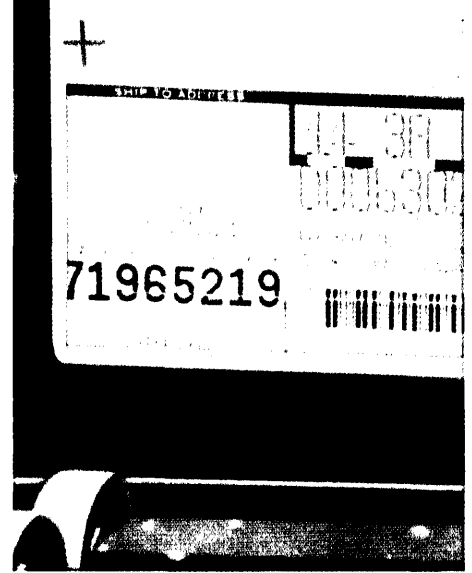
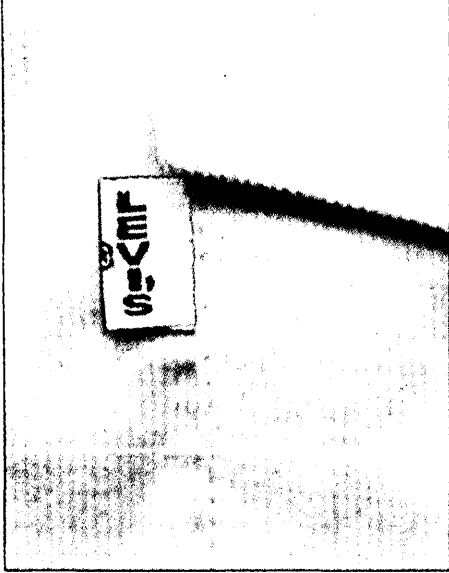

Packing for shipment (center) is the only manual handling of garments in the Levi Strauss Sportswear distribution center. Laser scanners (right) read labels so a computer can direct cartons through the conveyor system.

Levi Sportswear: Handle with Speed

Levi Strauss & Company, known for its jeans, is today one of the world's largest suppliers of other fashions as well. Its Sportswear Division can ship as many as 180,000 garments a day from a new divisional distribution center in Little Rock, Arkansas. The highly automated facility controls a total of 44,000 stock-keeping units.

Panatela, David Hunter, and Wildfire

"We run physical distribution as if our Panatela, David Hunter and Wildfire sportswear were perishable merchandise," says James Benson, national distribution manager for the division. "We have to be there with the

proper styles, in time to meet what customers are buying. Sales lost to stock outages can never be regained. Our operating goal is to ship every order within 24 hours of receiving it, and we are meeting that objective."

An IBM System/370 Model 145 computer keeps a digital "image" of all storage space in the 425,000-square-foot distribution center, and maintains a record of the inventory in each location. As cartons of garments are received from the factory, the labels are read by a laser scanner and the computer assigns them to storage locations.

When sales orders are entered, the System/370 generates picking tickets for customer shipments, which are passed

to the control computer, an IBM System/7. This machine monitors the conveyor system through sensors, and controls the movement of goods by actuating track switches, diverters and conveyor motors.

"The System/370 stores the dimensions of folded garments and calculates the proper-sized packing carton," Benson explains. "Order fillers pack the cartons, each is automatically sealed, a laser scanner reads the label, and the control computer diverts it to the right conveyor track for the selected carrier.

"The payoff is service," Benson adds. "When customers phone, we can query the system through a terminal and tell them the exact status of an order. For Levi Strauss Sportswear, physical distribution is not just a cost to be minimized; we believe it should provide a benefit to the company and to the customer. With the help of our IBM computers, we are meeting that goal."

Improving Project Management Skills

Executives, project managers and key DP development personnel can improve project management skills and educate users with the aid of *Managing the Application Development Process*, an Independent Study Program (ISP) available from IBM. It demonstrates how to plan, estimate, schedule, track and control an application development project from the defining of objectives through final testing. The course is based on the experience of IBM DP Services, a unit of the Data Processing Division.

Topics covered within the ISP workbooks and audio tapes include:

- The process of application development.
- Identifying elements of a successful project.
- Defining project objectives.

- Project tracking and control.
- Identifying level of risk and planning to contain risk.
- The role of systems assurance and planning for independent project reviews.
- Creating work and manpower plans.
- Establishing a reliable tracking and reporting system.
- The development of an estimate-to-complete.
- Developing guidelines for a standards manual.
- Saving useful data from completed projects.

For more information on this and other Independent Study Programs, contact your local IBM branch office or write to the Editor of DP Dialogue at the address on the right.

DP Dialogue is designed to provide you with useful information about data processing applications, concepts and techniques. For more information about IBM products or services, contact your local IBM branch office, or write Editor, DP Dialogue, IBM Data Processing Division, White Plains, N.Y. 10604.

Data Processing Division

Motivation? We will establish an impossible schedule and subtly imply that their failure to meet it is due to their own inadequacies.

left little finger to the first joint after 15 consecutive unsuccessful attempts to input a wet papertape through a rusty papertape reader.

We therefore elected to continue our study using that old standby, the white rat. Our initial experiments proved promising. Several of the rats were taught COBOL, which they learned (or at least, appeared to learn) with surprising ease. They quickly mastered the art of punching cards by jumping over the keyboard, although the long jump from the "3" key to the "Z" presented some problems for the smaller specimens. It was necessary to devise a latch for the numeric shift key since there is no way for a 6-inch rat to hold down a shift key which is 14 inches from the number keys which must be depressed simultaneously. We gave some thought to designing and installing a better rodent engineered keyboard, but we never got around to it.

Our initial success with the white rats proved illusory. Rats are rather short lived creatures and COBOL is, to understate the case, anything but a concise language. None of our rats lived long enough to complete even the shortest and simplest of COBOL programs (most were still working on the DATA SECTION when they expired of old age). Attempts to teach them other programming languages were an utter failure although one rat did produce a rather extensive program in what our colleagues in the mathematics department describe as "an ALGOL-like language."

At this point, it appeared that our project had come to an unsuccessful conclusion. However, just as we started to wrap it up, I was contacted by a gentleman from an unidentified government agency. This man, known to us only as "Charlie," expressed an interest in our project. After a series of meetings in the back booths of obscure road houses, a long, if chilly, consultation on a popular East Coast resort beach (in February) and an "accidental" encounter on a Vermont ski lift, a substantial amount of money in small, used, unmarked bills was made available to us. The nature of "Charlie's" interest in our project was never revealed.

Given a fresh infusion of money, we decided to try monkeys as subjects. It should be noted that at this point the project had gained a momentum of its own and had lost reference to its original goals. Laboratory monkeys were *not* cheaper than graduate students since the ASPCA and other organizations make sure that the former are ade-

quately fed and housed while the latter can be left to shift for themselves.

A group of half a dozen monkeys was procured and was trained in COBOL, FORTRAN, and PL/I. All six proved able to write programs in any of the three languages provided that they were given detailed, definitive specifications. Unfortunately, much of our time was consumed because of the primates' practice, apparently instinctive, of eating any page from the specifications which was erroneous or ambiguous. The monkeys would then sulk until one of us found the ambiguity or error and corrected it. In reviewing our work later it was recognized that we had stumbled upon a solution to the program documentation quality problem, but a majority of us felt that it was unlikely that the solution would find favor with either software designers or programmers.

Things were going well, and we had prepared a series of quite interesting experiments when disaster struck. Tired of setting up the monkeys' job decks for them (and, to be honest, piqued by their habit of jumping up and down, pointing and laughing whenever a job came back with a Job Control Language error, which happened with distressing frequency) we attempted to teach them JCL.

One monkey, a two year old female named Sarah, went into a cataleptic trance from which we have been unable to rouse her. Another, who was in critical condition for four days after eating an entire JCL manual (Acco fastener and all) in a fit of rage, has recovered, but refuses to have anything to do with computers. He is currently making good progress in a mail-order course in radio-tv repair.

A third monkey, Mike, has apparently concluded that JCL preparation is a random process. Although he uses the JCL manual in the initial preparation of his decks, his procedure for correcting errors consists of closing his eyes, whirling his chair around, and—with his eyes closed—striking random keys with his toes. Surprisingly, perhaps, this process works, but it is our subjective impression that it takes Mike at least twice as many runs as the average human requires to get a JCL deck debugged.

Two of the remaining monkeys studied the JCL manual for a few hours, and apparently decided that it was some sort of joke—and in rather poor taste. They adamantly refused either to write their own JCL decks or to use ours. We were forced to cut them from the proj-

ect. I understand that they have since formed their own company and are doing quite well on programming fixed priced contracts.

The remaining monkey not only learned JCL, he took to it so enthusiastically that he refused to work on routine programming tasks. He was able to master not only JCL, but the operating system's purported utilities which had, to that time, remained a complete mystery not only to ourselves, but to the computer center staff. For a time, we regarded his progress with admiration and pride, but he soon became a substantial annoyance reorganizing our disk structure "for greater efficiency"; "correcting" our JCL decks whenever he could get his hands on them (the corrections didn't always work, but he always had a good explanation why they *should* have worked); and "improving" our operating system, with unpredictable results.

Eventually we were able to control his activities by keeping our job decks under lock and key, and making it clear to him that he would be barred from the computer center if he continued to make unauthorized changes to the operating system. Nonetheless, his constant begging for small change to feed the coffee and cigarette habits he had acquired was a nuisance. None of us was really heartbroken when he expired from malnutrition, apparently as a result of his attempt to live exclusively on the food available in the computer room work area candy machines.

That summarizes our progress to date. The results of our current, and final, we feel, attempt at teaching non-humans to program are not yet in. We have overcome the technical problems of interfacing dolphins and standard computer peripherals, largely because of the recent availability of waterproof cards. The dolphins have had no trouble *learning* to program, but after an initial spurt of high productivity they have shown little desire to actually *do* any programming.

We are considering various methods of motivating them. A consensus seems to be forming around the concept of using a conventional motivational technique. We will establish an impossible schedule, and subtly give the impression that their failure to meet the schedule is due to their own inadequacies. We will back this up with vague threats of cutting off their salaries (paid in fresh fish) if they fail to come through.

We confidently expect to be reporting on the success of this experiment within six months or so. *

Distributed data processing from Basic Four.

Right system, right price!

The right system offers the option to make each remote location an independent data entry and processing center while providing the ability to exercise central control. That's what Basic Four computer systems do. And at the right price. Because there's a model to meet the exact needs of each location.

Powerful satellite computers

The key factor is how much each satellite computer can do. Basic Four computers are interactive, for instant transaction processing. Each is powerful enough to handle all order entry, accounting for each location, plus its specialized function—manufacturing, distribution, warehousing, whatever.

No more costly time-drains on the host computer. No more waiting for processing.

Easy to program, install, use

The data entry and processing needs of your remote

locations are like those of an independent business. And that's our specialty!

We offer proven software packages, with special application modules that are easily adapted to your particular needs. The language is BUSINESS BASIC, so programming is a snap. So is operation: we can teach a clerk to run a system in less than a day.

After 7 years experience, with some 5,000 installations, we can put in Basic Four systems on time and fast.

We talk to IBM all the time

Our distributed data processing capability means your network of powerful, self-sufficient satellite systems can communicate with each other, and with most large, host computers.

That adds up to a network that can be customized to meet your specific needs.

For full information, call our nearest office. Or write to Basic Four Corporation.

**MAT**

Basic Four Corporation / A Management Assistance Inc. Company
14101 Myford Road, Tustin, California 92680 (717) 731-5100

MEMORY MAXIMIZER:

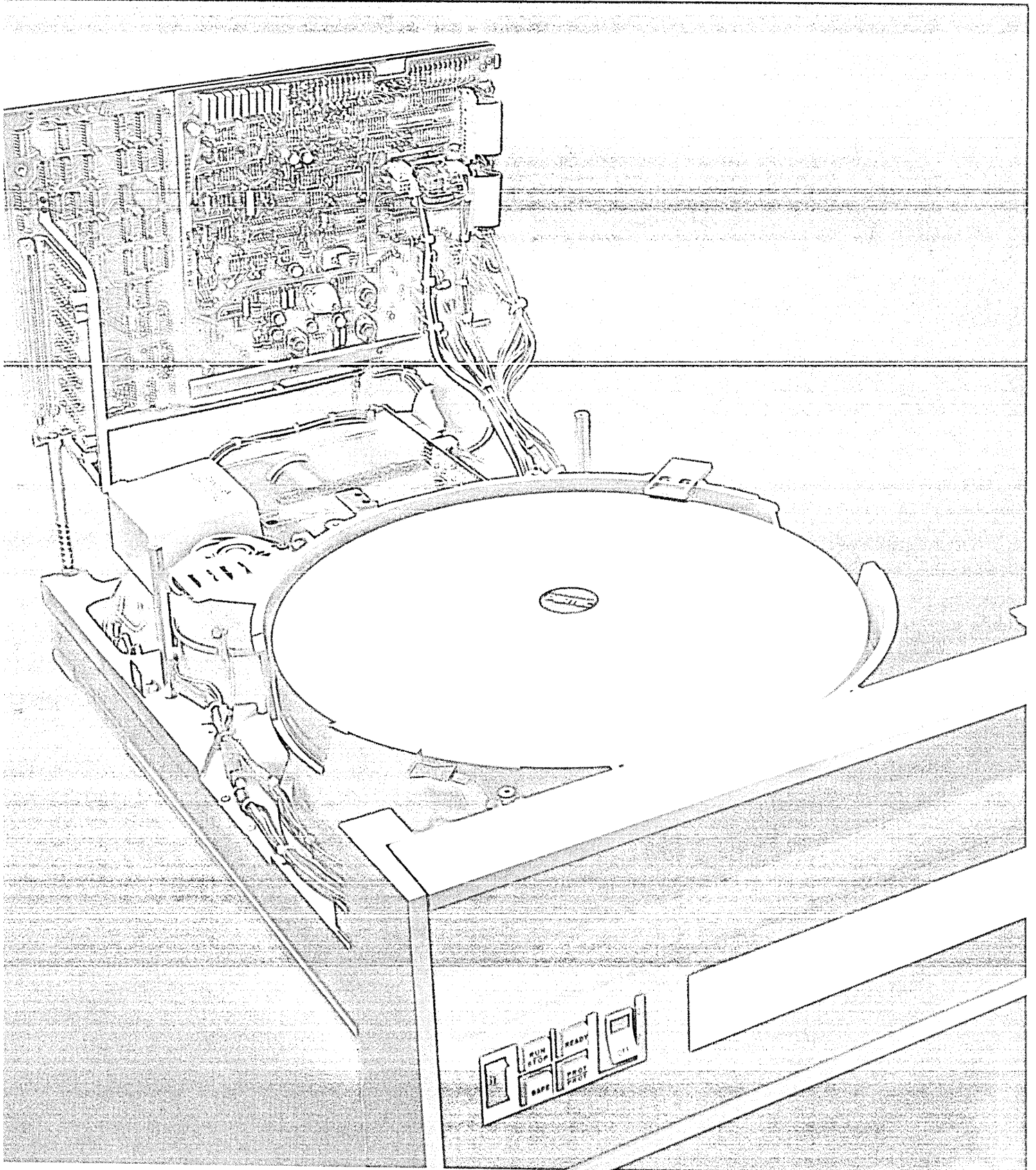

24 MB from one drive, without changing your controller.

Up to now, you had to settle for 3-12 MB capacities from single units. And sometimes, that's just not enough. So we've doubled the maximum on-line storage to a full 24 MB.

But we're not about to boost your data payload by burdening you with expensive penalties—in hard currency, or harder work. Like controller redesign. Like interface snafus. Like requiring special pre-recorded media. No way.

One unit: four platters. Available in front or top load models, the Pertec D3400 disk drive expands to 24MB through 3 fixed and 1 standard media-interchangeable cartridges. All with independent write protection.

Easy installation and maintenance. This 24 MB disk drive looks just like any 3-12 MB unit: same size, same rack space. And the same exclusive Pertec hinge-mounting of PCBAs—simplifies access to electronics, reducing operational and service costs.

Familiar technology. D3400 drives fit neatly into Pertec's most advanced disk product line, D3000—as members of a fast-access family you've been living with right along. And completely interface compatible with standard industry configurations. Ours *and* other manufacturers.

Champs in reliability. Each D3400 cartridge disk drive has to meet the same tough criteria—in production and on-line—that protects every Pertec product, and every OEM investment.

In short, we're producing a bigger storage appetite, but assuring you the same pre-tested, high performance, field-proven drives that have made Pertec the odds-on favorite with OEMs for years.

No-compromise service. One out of five people in Pertec Computer Corporation is a full-time contributor to one of the most comprehensive OEM-support organizations in the field today.

Our sales service expands and cost-optimizes your configuration options: we'll help you target in on the D3000 system that precisely meets your specs—pick from 3MB to 24MB on cartridge disk. And the same support goes for our fixed and flexible disk drives—just ask. Our field service facilities are located strategically throughout the world.

It's that kind of commitment that ranks us today as one of the world's largest independent manufacturers of peripheral equipment.

- Please rush full information on Pertec's 24 MB cartridge disk drives.
 Send pricing information based on RFQ below, without obligation or cost.

Request for Quote

Cartridge Type	Capacity (Megabytes)	Platter Configuration	Bit Density (bpi)	Speed (rpm)	Model Number	Quantity Required	Date Wanted	Send Specs Only
5440 Top Load	24.0	QUAD	2200	1500	D3461			
				2400	D3462			
2315 Front Load	24.0	QUAD	2200	1500	D3481			
				2400	D3482			

Name _____

Title _____ Phone _____ Ext _____

Please attach coupon/RFQ to company letterhead and return to Pertec, 9600 Irondale Avenue, Chatsworth, CA 91311.

For immediate requirements, call your nearest Pertec regional sales office: Los Angeles (213) 996-1333. Ann Arbor, Michigan (313) 668-7980. Hudson, New Hampshire (603) 883-2100. England (Reading) 582115.



PERTEC DIVISION

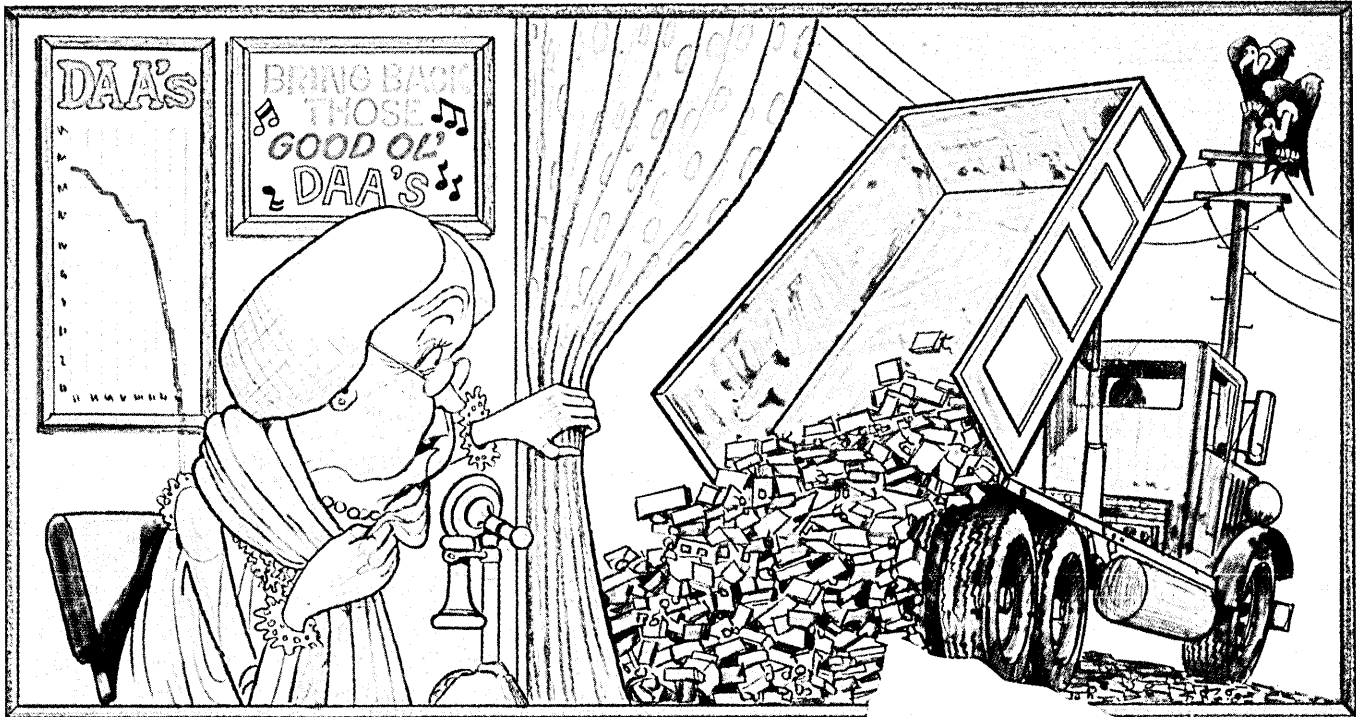

Dear Ma:
You may be getting back some DAAs now that Vadic modems no longer need them.

A lot of folks will be moving out of your high rent district, Ma, now that Vadic is delivering direct connect 300bps and 1200bps modems, the first to be registered under Part 68 of the new FCC rules.

It's an historic occasion, because modem users happily will no longer have to spend from \$4 to \$8 each month buying your Data Access Arrangements (DAAs). Instead, the new Vadic modems connect directly to the telephone network using the FCC approved data jack.

For end users, they are available with Vadic's powerful displays and diagnostics, either in a stand-alone cabinet, or in the Multiple Data Set System where up to 16 modems (including built-in DAAs) take up just 7 inches of vertical rack space. OEMs can buy the modems packaged on a single PC board.

These direct connect products are compatible with your 103s & 202s and also include Vadic's VA3400 full duplex 1200bps modem. By the way, Ma, Vadic also has a new triple modem that automatically becomes a 103, a 212 or a VA3400!

Better get the whole story, Ma, by phoning or writing Vadic today.

Your independent thinking son,

PS: Vadic has shipped over 150,000 modems to date.

Alexander Graham Jr.

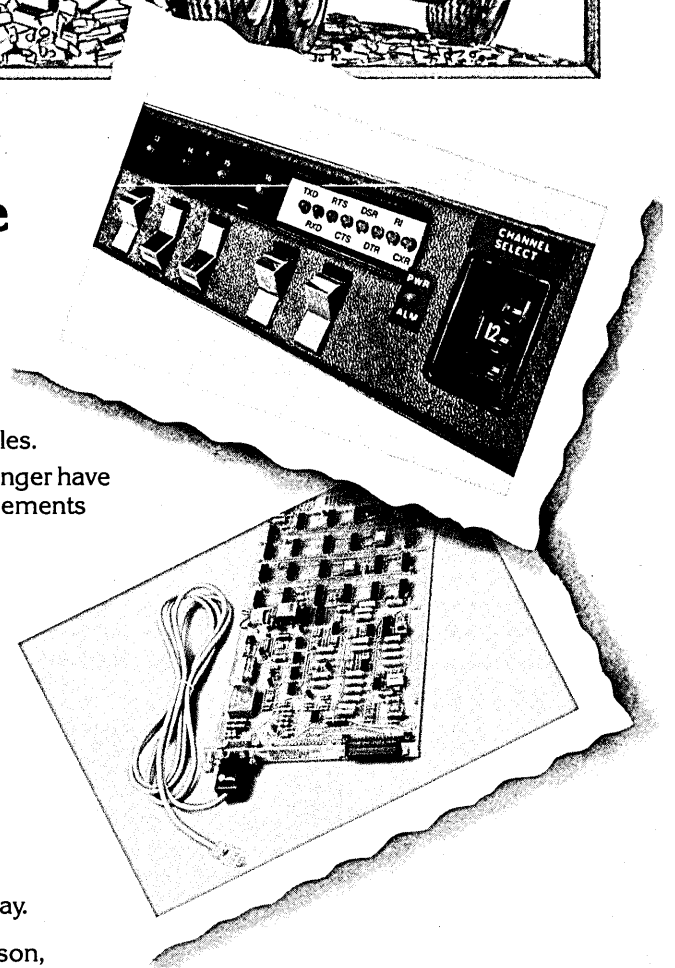

Racal-Vadic the new name for



Member of IDCMA

222 Caspian Drive, Sunnyvale, CA 94086 • Tel: (408) 744-0810 • TWX: 910-339-9297



CIRCLE 113 ON READER CARD

The most prominent characteristic of the field is its rapid rate of change.

GETTING READY FOR WORD PROCESSING'S SECOND GENERATION

by C. B. Carls

When I announced to the three secretaries outside my office that we were going to remove their word processing terminals, two of them threatened to have me mugged and the third said "No way am I going back to washing my clothes on a rock!" They needn't have worried; we'll replace their systems with more capable ones, not with typewriters.

We're sold on word processing, and use several varieties of it. Our company has been using some form of it since the late 1960s—although it wasn't called "word processing" then. In fact, we thought we'd gotten to be old hands at the subject until we went out to evaluate a replacement system. That was a comeuppance.

It's been about 10 years since we installed IBM's Administrative Terminal System (ATS) in Hughes Aircraft Company's corporate data processing center near Los Angeles. We were neophytes at it then, but by now we have modified nearly every module in the package, or purchased or swapped for other enhancements until the existing ATS looks very little like the one we first acquired. Our system has grown to support 136 active user sites throughout Southern California and Arizona. We handle up to 80 concurrent users who access space on six IBM 3330 Model I disks which are connected to an Amdahl 470 V/5.

ATS is used—sometimes misused—for applications ranging from proposal writing, brochure preparation, data entry, parts lists, budgets, a ton of mini-applications, trip reports, and all those other cases where the author wants to change his mind four or five times before the final copy is produced.

Although the Amdahl-based system is the single most used one for text preparation of any kind, we also have several standalone WP configurations scattered around. Therefore we've gotten used to the large and small scale ends of the business.

So it was that we had a great deal of confidence when we began a

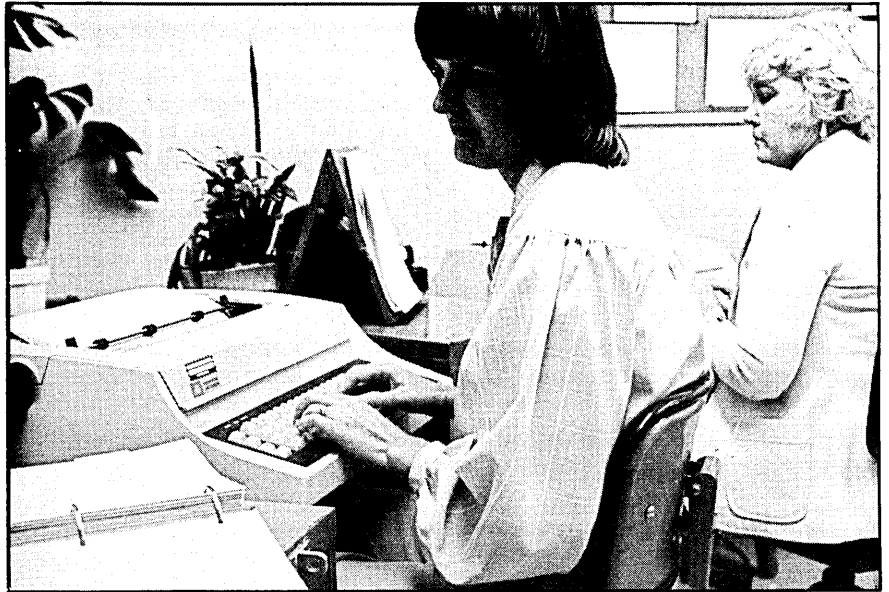

search for a new system. That was two years ago.

IBM's ATS has been used at Hughes Aircraft Co. for almost 10 years, and is currently running on an Amdahl 470 V/5. Although showing its age, the system handles up to 80 concurrent users and is accessible from 136 active user sites throughout Southern California and Arizona.

By 1976, ATS had patches on top of patches and was showing its age. Our two biggest problems with it were the inordinate amount of time needed for the master terminal operator to move data into or out of ATS for batch processing, and the less than satisfactory "interface" between ATS and the system control program—unlabeled tapes.

COLLECTING THE DATA

We assembled a project team consisting of a system programmer, a person responsible for a standalone WP system at one of the sites, an engineering type, and an administrative coordinator. Naturally each of us had different WP needs, and we began our study by compiling a list of the features each of us wanted in a word processing system. It was a long list. (See Table 1.) To organize it, we attempted to rank the important items at the top of the list, or to weight them, or to drop some less important ones.

Then our education began. What looked to be of little use to one of us was critical to another. Users composing proposals on-line didn't care about the letter writing feature, but others used the systems primarily for letter writing. The letter-writers couldn't have cared less whether the system was capable of filling in leading dots like those used in a table of contents, but the proposal-writers couldn't do without them. And on it went. In the end, we alphabetized the features and kept them all.

Only slightly daunted, we set off to find which vendors provided which features, inwardly hoping that some vendor would be able to check off most of the items as "available off the shelf." We decided that an ideal system would provide the following:

- an easy to use, comprehensive set of text editing and data manipulation commands
- some arithmetic and text sorting capability

Begin by getting the data into machine readable form, even if the choice of machine hasn't been made.

- a video display terminal (nonglare) with 132 horizontal character positions and at least 55 lines
- hardcopy printing at a terminal or spooling to a high speed line printer, with resulting camera-ready copy
- an interface for photocomposition, microfiche, and graphics systems
- communications with other processing systems
- large scale data storage, archive, and access

We're the first to admit that our list is biased, especially to data processing needs. The point is that potential users should come up with a list which reflects what they need, not what the vendors advertise.

The vendors present enough of a problem in using the checklist anyway. Our first vendor-related stumbling block was in learning to communicate in the same language with the various suppliers. It appears that in the wacky world of word processing they cannot even agree among themselves on the differences between "text processing" and "word processing." Other problems related to selling techniques much like those in vogue on used car lots, which we presume most buyers can handle, and the ever-popular "oh yes, that's on the drawing boards and will be available whenever you are."

In spite of vendor hassles, we brute-forced the study through to completion. We learned a good deal by doing it, including: (1) how to determine whether a word processing system is cost justified for a given application; (2) the advantages and disadvantages of a small standalone WP system compared to a large scale on-line system like ATS; and (3) that the product information matrix, the end result of our project, was of little lasting value.

We used the following relation to compute the crossover point between manual and automated methods of document production, the number of pages one must produce each year before the WP systems begins to pay for itself in cost savings:

$$\frac{\text{WP system fixed costs}}{\text{difference in page costs}} = \text{crossover point}$$

Simply stated, dividing the annual cost of the WP system by how much it saves per page tells you the number of pages per year you must produce before the system is cost justified.

It's an easy relation to use. The hard part comes in figuring out what it costs to produce a typed page using a typewriter and what it costs on the WP system.

For Hughes, we assumed that the typewriter was paid for and the only costs of producing a typed page was the typist's salary. For most of the documents we produce—proposals, manuals pages, etc.—we have found the following time estimates to be realistic:

- first draft 30 minutes
- coordination draft 30 minutes
- final copy 15 minutes

At first glance, the numbers seem very high, but they are not unrealistic in our environment, considering all the changes an author makes and the complexity of the material being typed. Someone else's numbers may be quite different, but the method is the same for any application.

Compare that time to the time for preparing documents using ATS, for example:

- first draft 14 minutes
- coordination draft 7½ minutes
- final copy 6 minutes

Thus, to calculate the crossover point or breakeven point in converting from manual methods to ATS, the following numbers plug into the equation:

■ WP fixed costs	\$1,900 (rental of the terminal)
■ Manual cost/page	\$11.24 (approximately \$9/hour including fringe benefits)
■ WP cost/page	\$6.42 (at \$9/hour plus ATS costs)
	$\frac{\$1,900}{\$11.24 - \$6.42} = 394$

For this case, it is cheaper to use word processing instead of manual typing if only 395 pages per year are produced. And in practice, more than one user can contribute to the 395 pages if they are close enough to use the same terminal and have similar applications.

PLUSES AND MINUSES

We were in a unique position to contrast the advantages and disadvantages of large scale and small scale word processing systems. Sometimes, even old ATS didn't fare so badly in the comparison.

Large scale on-line system advantages

- On-line systems can support more concurrent users, and more easily accommodate growth. Smaller systems tend to get the "slows" when additional devices are added, or to have unacceptable limits.
- On-line terminals can be used to access other subsystems, such as TSO, in addition to supporting word processing applications.
- Extremely large documents can be processed more easily, and quick access provided to any portions of those.
- High speed printing facilities are made available.
- Immediate access can be provided to a large volume of documents stored on direct access devices.
- Sorting can be accomplished, either directly or through spooled access to the host.
- Less floor space is required in the user area; only room for the terminal, modem, and workspace is needed.
- Routines can be added to the software more easily.
- Massive or frequent changes are readily accomplished.
- The per workstation cost is lower; per station costs actually decrease as the network grows.

Standalone system advantages

- The system is more readily available, 24 hours per day, 7 days per week if desired. The user is not tied to the schedule of the mainframe.
- The use of classified or sensitive data is easier to control. The system can even be locked in a room if desired, and there is no need to transmit sensitive information outside of that room for processing.
- The installation is easy. The system is ready to go when placed on the site.
- Users may be able to choose a system more precisely tailored to their needs—if those needs are fixed.
- The software may be less complex.

Some factors may be a push as far as comparisons are concerned. For example, the same printing mechanisms are available for printing at the user site or central site. Similarly, the ease of use is proportional to the complexity of the system and the features offered (although standalone versions are usu-

WORD PROCESSING SYSTEMS CHECKLIST

Format control

Auto centering
 Auto format control
 Auto hyphenation
 Auto indentation
 Auto leader dots
 Auto page numbering
 Auto right justification
 Auto underscore
 Automatic table of contents/
 index creation
 Box item in text
 Bury comments within text
 Figure title control
 Footnotes
 Form letters without operator
 intervention
 Include text by file name
 Justified block format
 Keep/release mechanism for
 assuring a section of text
 is not broken up
 Letter writing package
 Maximum line width setting
 required
 Maximum number of lines per
 file required
 Maximum page depth required
 Number of text columns required
 Odd-even headings/footings
 Optional line spacing
 Page number reset—actual/relative
 Revision bars in margin
 Scientific or math notation
 Subheadings/footings
 Substitute symbol/switch code
 Super/subscript
 Translate characters
 Upper/lower case Roman page
 numbering
 Variable line widths within a page
 Variable page lengths within
 a file
 Widow line control (treat left-
 over line as "keep")

Session commands and software features

Background processing via
 command
 Block moves
 Boolean compares
 Compare file versions

Copy portion of file
 Duplicate *n* number of times
 Front to back editing
 Full cursor edit
 Full screen editor
 Instant display of changes
 Line correction during input
 Locate and list/count occurrences
 Locate/change first, range, or
 all occurrences
 Multiple commands/corrections
 per line
 On-line sort
 Programmable (soft) keys
 Repeat next command *n* number
 of times
 Session elapsed time printed with
 sign-off
 Set terminal message on/off
 Single/multiple line deleting
 Stack commands
 Suppressed password with sign-on
 Upper/lower search/change
 User-executed background sort
 User message switching
 User requested archive list

Terminal devices

Auto reset terminal status
 Boldface
 Crt support
 Full cursor edit
 Hard copy input/output devices
 Maximum display line hard copy
 Maximum display line crt
 Pitch changes
 Printing speed required
 Scrolling capacity
 Transmission code (ASCII,
 Correspondence?)
 Type font

Disk processing

Auto file save
 Growth option
 Hardware types supported
 List files
 Massive file delete
 Maximum length of file name
 Optional disk formats
 Partial file retrieval
 Rename file

Resave file
 Restrict other users from
 read/write
 Save portion of file
 Selective list of files
 Storage device file capacity
 required
 Tape file to permanent storage

Tape processing

Device type
 Label input/output
 Optional purge with archive
 retrieval
 Print from archive tape
 System lookup (auto) archive
 retrieval
 Tracks/density required

High speed print

Bulk transmit
 Direct printouts to another
 user-ID's mail banner
 Dynamic allocation for remote
 printing
 File released directly to print
 queue
 Manual updating of forms validation
 table
 Maximum line length
 Microfiche interface
 Multiple copies option
 Photocopy (high quality output)
 interface
 Print abort (dequeue) message
 to user
 Proportional spacing
 Remote printing option
 Repro quality output
 User controlled hold/delete/
 release
 Variable point size
 Various font styles on same page

Accounting

Change session accounting
 Disk accounting compatibility
 required
 Performance statistics
 Peripheral accounting compatibility
 required
 Session accounting data
 compatibility required *

Table 1. Potential customers for word processing systems are urged to compile a checklist of features they require in a system. The list should be kept to a reasonable size (perhaps unlike the one the Hughes study team developed) and the items should be weighted or listed in order of importance. The

list becomes a valuable tool for evaluating systems; its compilation provides valuable side benefits as well, such as forcing a department to categorize and define its word processing requirements.

Hard copy made easy.

With the help of a high-speed microprocessor, Hewlett-Packard combines exceptional performance and convenience in a new low-cost printer and printing terminal.

The HP 2631A printer and HP 2635A printing terminal with alphanumeric keyboard are the first members of a new Hewlett-Packard family of hard copy terminals.

Each machine was designed to give you a number of high-performance features. And both can support a variety of interfaces, including RS232 and CCITT.V24, to fit into systems made by HP and other manufacturers.

Bi-directional printing increases throughput. Both printers zip along at 180 cps in both directions, depending on your line layout. The microprocessor chooses the quickest path, and increases the speed even more by suppressing leading and trailing blanks.

High-speed slew for columnar data. When the microprocessor senses more than ten blanks in a row, it slews the print head at 45 inches per second to the next print position.

Three ways to print. The Character Compress/Expand Modes let you print more data on a page and emphasize points with headlines and titles. You can get as many as 132 characters on an 8-inch line, or 227 on a 14-inch line.

High-quality print, with six copy resolution. A 7 x 9 dot matrix (versus the usual 7 x 7) gives you clear, crisp printouts, right down to the sixth copy and meets the 128-character USASCII standard. And the extra two dot rows allow true underlining and descenders without character blurring.

Programmably interchangeable character sets. The HP 2631 can be made to print alternate character sets without reconfiguring the printer.

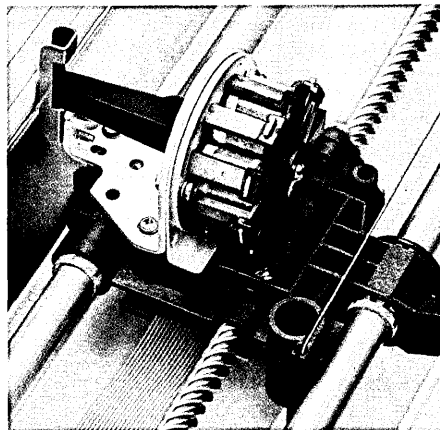

Long lasting, quick change print head saves service calls. The 9 wire print head is conservatively rated at a 100 million character life-span. It's also self-aligning. When you finally replace the head, you can do it yourself in a couple of minutes.

Long-life cartridge ribbon for a clean change. With a life span of at least 10 million characters, this innovative drop-in cartridge takes the mess and trouble out of ribbon changes.

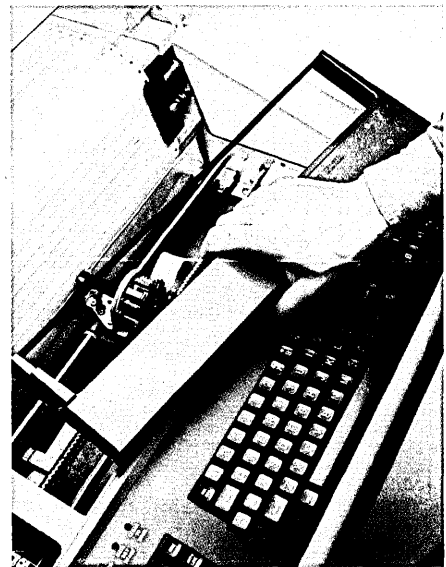

Self-test for quick status checks. One key tells you if the printer is ready to go. If it isn't, the self-test feature helps you isolate the problem, reducing the time and cost for repairs.

Run everything under program control. All the features described and more can be programmably controlled. The software can take you in and out of the various modes. Or you can make a change yourself using one of the front panel switches or keys.

In a network or as part of a stand-alone system, HP now makes it simple to get the hard copy you need. If you'd like to see our printer or printing terminal in action, call the Hewlett-Packard sales office listed in the White Pages and ask for a computer systems representative. Or send us the coupon.

Yes, I'm interested in your new
 Printer Printing Terminal.

- Have your representative contact me.
- Send me more information.
- Send me OEM information.

Name _____ Title _____

Company _____

Address _____

City/State/Zip _____

Phone _____

Mail to: Bill Murphy, Marketing Manager, P. O. Box 15,
Dept. 408, 11311 Chinden Blvd., Boise, Idaho 83707

*Fast, efficient
and economical:
the new printer and
proofing terminal from
Hewlett-Packard.*

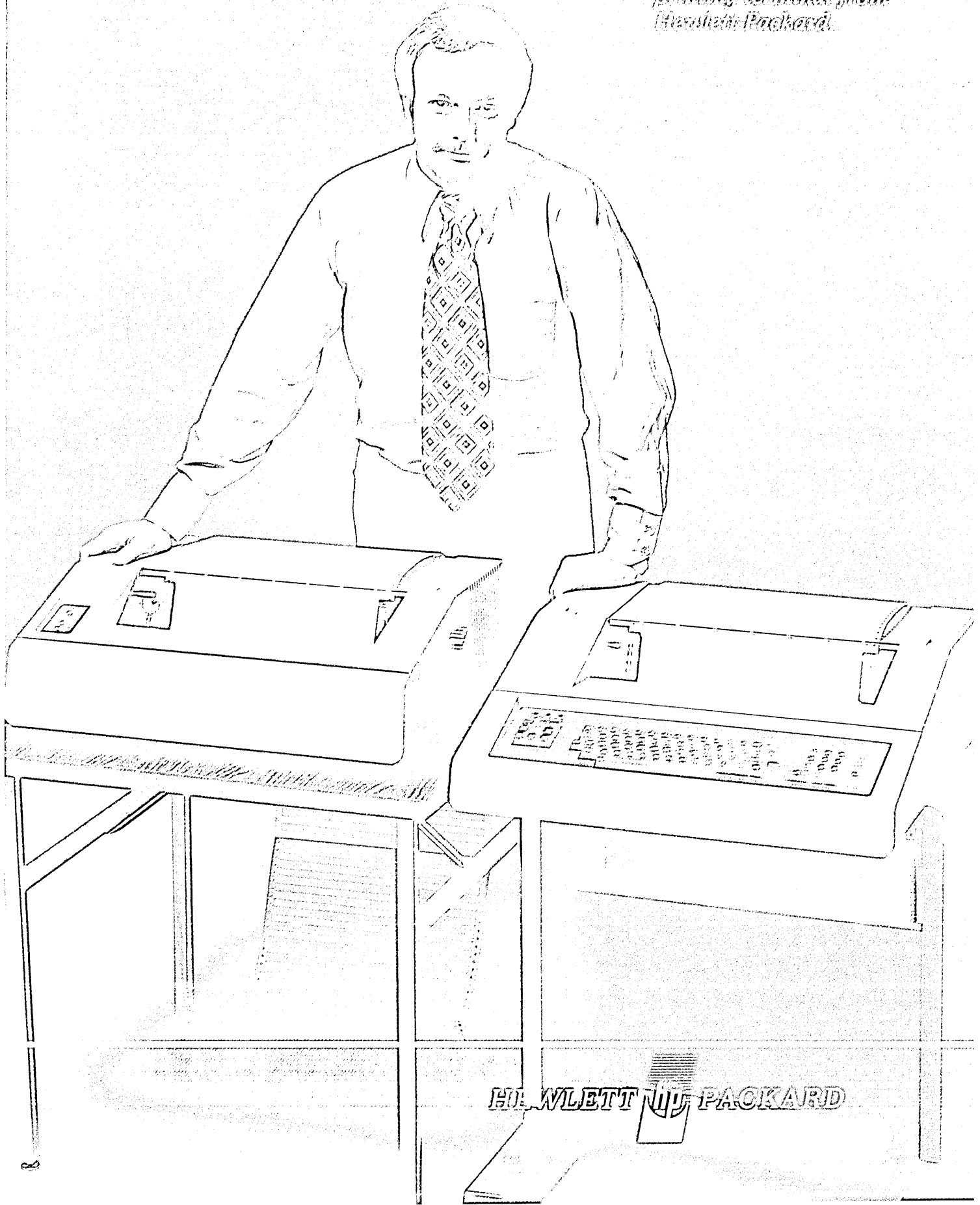

HEWLETT  PACKARD

Don't wait until the system is installed to get the data ready for it.

ally available in a less complex form than the minimum on-line system).

GETTING READY

The most important thing we learned in the survey project was how dynamic the field really is. The product feature matrix we built 12 months ago is now useless—not just out of date, but useless. The rate of change we're seeing will continue, too. As the cost of labor increases and software/hardware combinations become more economical, management throughout the country is taking a closer look at how to process words and vendors are coming up with more and more attractive packages to get managers' attention.

Faster printout speeds, more interfaces for photocomposers, and improvements in micrographic equipment are being announced daily. Camera-ready copy for volume reproduction is becoming much easier to produce. Practical color displays are just around the corner, as are larger display surfaces.

The only place where there seems to be a delay is in the software gap. Mini manufacturers are producing some very reliable hardware, but their word processing software leaves much to be

desired. We can reasonably expect that to change as well.

Fortunately, word processing managers can begin to prepare for the new systems without first deciding which one to acquire. The first step in that preparation should be to document the current word processing workload. How big is the volume? Are the documents usually originals, revisions, form letters, proposals? Is a special notation needed, as for scientific work? What about the formatting? Usually columns? Usually straight text? Are there special requirements, as for security? For archival storage?

The second step should be to choose the appropriate items from Table I or some list like it to produce a checklist for evaluating products. If possible, weight the items or group them according to importance.

Then visit other users. It's surprising how much one can learn that way.

Don't wait until the system is installed to get the data ready for it, either. Begin by using typewriters with ocr fonts, so that existing paper documents can serve as input for magnetic files later. Or use a service bureau to get your feet wet, at least on a casual

basis. Service bureaus are a good start for a variety of reasons, including getting used to large scale equipment if that becomes your choice, or getting the data ready for conversion to smaller standalones if you go the other way. The big gain will be in experience.

Get that experience now. Chances are you'll need it very soon.*

C. B. CARLS



Mr. Carls is head of the administrative systems section within Hughes Aircraft Company's corporate data processing

center. He began his career in data processing in the late 1950s with Occidental Life in Los Angeles, programming the IBM 650. At Hughes over the last 15 years, his responsibilities have spanned financial system design and programming, operating systems, hardware configuration management, standards development, and staff services.

Still squeezing data through the old-fashioned way?

If you would like to put up to 16 asynchronous terminals on one telephone line, read on.

MICOM's smart Micro800 Data Concentrator has obsoleted the good, old-fashioned TDM or time-division multiplexor. If you prefer to call it a statistical multiplexor or intelligent TDM, feel free. Either way, the Micro-800 provides retransmission on error and, typically, double the efficiency of TDM. It's not a penny more than a TDM, so why not order a pair on a sale-or-return basis? No strings attached.

Concentrate. It's cheaper!

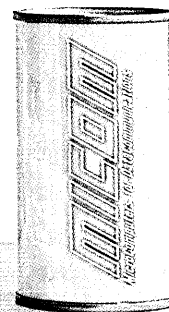
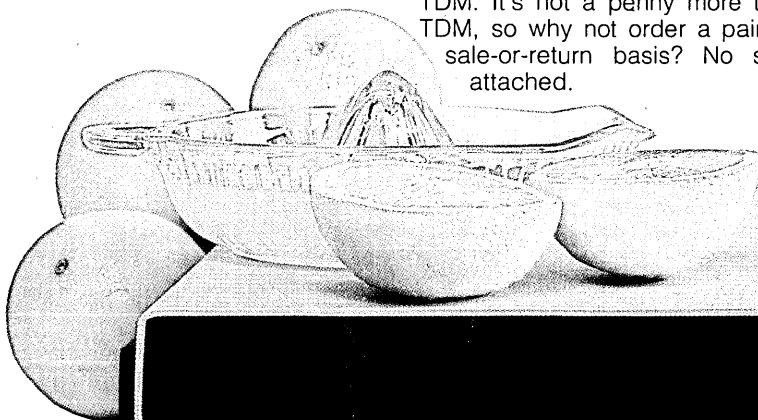

OVER 500 UNITS INSTALLED

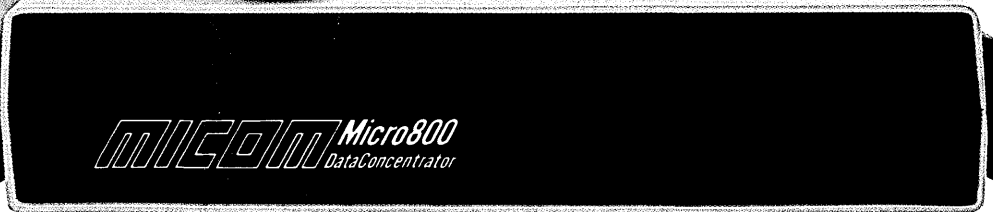

MICOM MicroComputers for DataCommunications

MICOM SYSTEMS, INC. • 9551 Irondale Ave. • Chatsworth, CA 91311 • Tel. 213/882-6890 • TWX 910/494-4910

How Diablo improved my appearance.

By A. Letter

I didn't always look this good.

Sometimes I was even embarrassed to go out of the office. Then one day, my boss introduced me to the Diablo 1355 WP metal-clad print wheel. Suddenly my characters were coming out crisp. Proportionally spaced. And uniformly dense.

Since I discovered that Diablo has over 100 type styles, I'm never bored either. There's 88 characters to choose from in English. And 92 in foreign fonts. And the future looks even better. Because soon there will be 96 characters to choose from.

And thanks to the Diablo 1355 WP, I never have to worry about keeping up with the pace. Because the metal-clad wheel prints 40 characters-per-second.

It's durable too. In fact, the wheel that printed me today was no youngster. It was over 16 million characters old, but you'd never know it to look at me.

Not that I'm vain. But I am "camera ready" as soon as my page is finished.

And in my line of work it's important to make the right kind of impression.

Of course, it's only since they started using the Diablo 1355 WP metal-clad print wheel that I really became letter perfect.



XEROX

Diablo and XEROX® are trademarks of XEROX CORPORATION.

CIRCLE 8 ON READER CARD



EDUCATIONAL ENTERPRISES

presents

Chorafas World Seminar 1978

on

**THE DESIGN AND MANAGEMENT OF DATA COMMUNICATIONS;
DISTRIBUTIVE SYSTEMS; TELEPROCESSING; PROTOCOLS;
DATABASES; NEW TECHNOLOGIES AND THEIR APPLICATION;
COST ADVANTAGES AND BENEFITS POSSIBLE FROM CLOSER
LINKS BETWEEN COMPUTER AND THE MANAGEMENT
OPERATION.**

18-22 Sept. DALLAS	SHERATON DALLAS
25-29 Sept. BOSTON	RAMADA INN
6-11 Nov. FRANKFURT	HOTEL INTERCONTINENTAL
20-24 Nov. PARIS, FRANCE	HOTEL SHERATON

Dr. Dimitris Chorafas, a dynamic lecturer and former professor in major American universities is today the foremost authority in Europe with unique experience in the realm of computers and data communications. This Seminar provides indepth insight into this rapidly growing field with special emphasis on decision criteria, cost benefit and administration of the human resources necessary to use data systems competently.

For brochure with full detailed information, post the coupon or write AIRMAIL to Educational Enterprises, 26 Coniston Road, Blackpool, FY4 2BY England or phone (0253) 21840 or 403016, or Orsys. 17 Ave. Henri Barbusse, 94240, L'Hay les Roses France (phone 661 02 24), or K & G Consulting, GmbH, Roonstr. 1, 8500 Nuernberg 1, (phone 0911/26 70 04 Telex 0626415 PROM D) West Germany.

Reservations may be made by telephone or cable to Educational Enterprises or by completing application form in brochure. Discounts are available for early bookings or group bookings.



Please send me full details of the Chorafas World Seminar 1978 to be held in _____ (state location) as soon as possible.

NAME: (please print) _____

ADDRESS: _____

COMPANY: _____ PHONE: _____

TWO FOR THE ROAD

TI's Portable 745 and 765 Terminals.

Our *Silent 700** Portable Data Terminals make excellent traveling companions. They don't take up much room — they'll fit under your airline seat. They're light on their feet — the 745 weighs 13 pounds; the 765, 17 pounds. They know how to keep quiet — they're virtually silent when you're entering, printing and transmitting data on their typewriter-like ASCII keyboards. And while you're out of the office, they can put your office and all your data at your fingertips by printing hard copies of crucial information at 30 characters-per-second, using a built-in acoustic coupler.

The 745 is the lower cost, lighter version, without bubble memory for applications that do not require off-line data entry. It's also available with optional full ASCII/APL keyboard. Like the 765, its microprocessor-based control assures reliability and high-performance capabilities.

The 765 Portable Memory Terminal incorporates nonvolatile bubble memory which retains data, even with the power source off. The 765 can spend all day taking sales orders, real estate listings, insurance information, newspaper stories, or performing any data entry function. Or, following through on time-sharing applications.

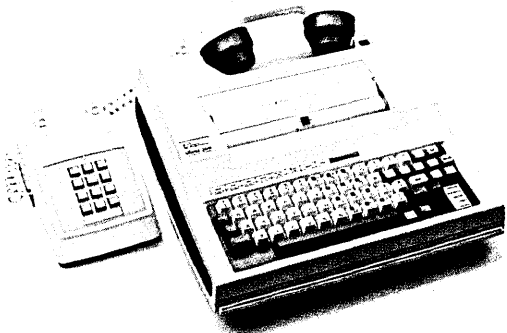

You can edit off-line, to correct or add data on the spot. And wait until telephone rates are lower at night to batch-transmit your data.

No matter how far across the country your travels take you, with a TI portable terminal, you're backed by

over 30 years of experience in the electronics industry, the technical support of our worldwide organization of factory-trained sales and service engineers, and our TI-CARE† nationwide automated service dispatching and field service management information system.

To see how we can put one of our "two for the road" terminals within your reach, call your nearest TI sales office, or write Texas Instruments Incorporated, P.O. Box 1444, M/S 7784, Houston, Texas 77001, or phone (713) 937-2016.

Yes! I am interested in the 745/765 Portable Terminals.

- Please have your representative call me.
 Please send me more information.

SILENT 700
 electronic data terminals

Name _____

Title _____

Company _____

Phone _____

Address _____

City _____ State _____ Zip _____

Mail to:

TEXAS INSTRUMENTS

INCORPORATED

P.O. Box 1444, M/S 7784, Houston, Texas 77001

21-9-DM

*Trademark of Texas Instruments

†Service Mark of Texas Instruments

Copyright © 1978, Texas Instruments Incorporated

TEXAS INSTRUMENTS.

We put computing within everyone's reach.

floppy Two heads are better than one

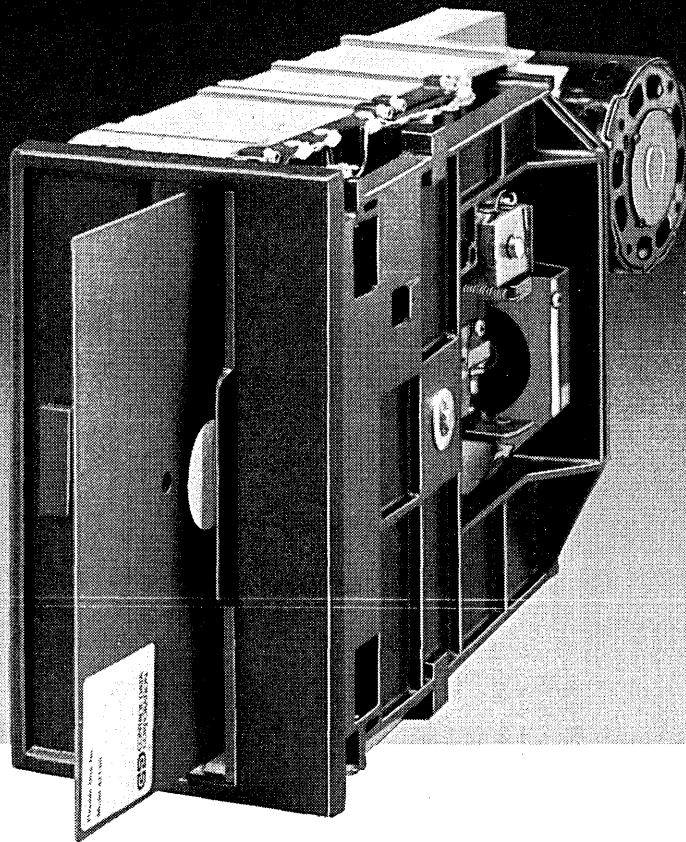

Our 9406 OEM flexible disk drive. It looks identical to our single-sided drives. Same dimensions and mechanical mounting. Even shares common interface protocol.

But our 9406 has two read/write heads for two-sided media.

That means you can provide your customer with up to 1.6 megabytes of random-access storage in less than one cubic foot. We've more than halved the access time, too. Only 3 ms. track-to-track. And depending upon your application, the 9406 can be operated in either one-or two-sided mode as well as single-or double-density formats.

The 9406 is the latest member of our flexible disk drive family. It incorporates all that we've learned from building more than 100,000 single-sided floppy disk drives for our OEM customers.

We'd like to share that experience with you. Let us show you the advantages of our unique head design that is easy on media. Let us demonstrate the quality and service our customers expect from Control Data.

Put quality behind your nameplate. For more information, call 405/946-5421. In Europe, contact one of our European representatives. Or return coupon to:

D98

Chet Baffa, Product Sales Manager
Control Data Corporation
4000 N.W. 39th St., Expwy.
P.O. Box 12313
Oklahoma City, Oklahoma 73112
Please tell me more about your 9406
flexible disk drive.

Name _____ Title _____

Firm _____ Phone _____

Address _____

City _____ State _____ Zip _____

CD CONTROL DATA
CORPORATION

More than a computer company

THE NEC SPINWRITERS:

PRINTERS MADE FOR PEOPLE.



It takes craftsmanship and attention to detail to make a fine automobile, a fine watch, or a fine character printer. Those qualities, available at low cost, have made the Spinwriter family from NEC Information Systems the finest character printers available.

Spinwriters offer performance beyond that of today's best character printers, at prices averaging 10 percent below competition. But NEC craftsmanship extends beyond performance and price, to features designed for the people who use Spinwriters. No other character printers are as easy to operate, as reliable, or as easy to repair.

Die-cast aluminum housings lined with sound-absorbing foam make Spinwriters quieter than office typewriters — and as easy to use.

Spinwriter housings swing open for easy operator access to ribbons and the thimble element, and easy access for service personnel to Spinwriters' modular components. Ribbons, thimble elements, and forms-handling modules can be replaced within seconds.

Spinwriter keyboard send/receive (KSR) printers also provide easier operator access to controls offering more functional capabilities than other character printers provide. A thumbwheel switch enables your operators to specify the precise forms length desired, and they can specify vertical spacing at

either six or eight lines per inch. The unique Spinwriter self-test feature is enhanced to include the interface and communications lines in on-line applications.

Compare Spinwriters with the printers you use now, and see how NEC craftsmanship makes Spinwriters different. See the difference in Spinwriters' smooth-contoured styling, and feel the difference in durability. The appearance, and the ruggedness of Spinwriter printers allow them to fit well in every environment.

Tell me more about the Spinwriter family.

- Please have a sales representative call.
 Please send literature.

DM978

Name: _____

Title: _____

Company: _____

Street: _____

City: _____ State: _____ Zip: _____

Telephone: _____

To find out more about how NEC craftsmanship makes Spinwriters the finest character printers available, fill out the coupon, or call NEC Information Systems, Five Militia Drive, Lexington, Mass. 02173 (617) 862-3120.

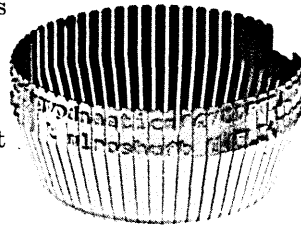

NEC

NEC Information Systems, Inc.

Eastern Office: NEC Information Systems, Inc., Richard Gilbert, 5 Militia Drive, Lexington, Massachusetts 02173 (617) 862-3420.

Central Office: NEC Information Systems, Inc., Steve Kadash, 3400 South Dixie Drive, Suite 105, Dayton, Ohio 45459 (513) 294-6254.

West Coast Office: NEC Information Systems, Inc., Marty Rubin, 8939 S. Sepulveda Blvd., Suite 330, Los Angeles, California 90045 (213) 670-7346.

SIEMENS

Laser Printer ND-2. 21,000 lines per minute. Fast is not the word for it. Fastest is.

Speed plus practicality.

The ND-2 was designed to print 21,000 lines per minute (that's 8,000 12-inch printouts per hour). But speed isn't everything. You also need practicality. Plain paper printing stock. User changeable printing drum... and then only after 3 million perfect copies.

One good benefit deserves another. And another.... and...

The ND-2 Laser Printer duplicates, masks out at different positions in the copies, prints with variable fonts and also different character sizes and spacings within the same line, and gives you the choice of three line spacings. The ND-2 also utilizes a forms overlay feature, thus eliminating the need for preprinted forms. Even at top operating speed, the character quality is suitable for OCR applications.

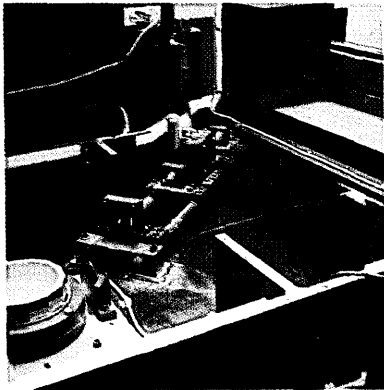

Fastest is not the only word to describe the Siemens ND-2 Laser Printer. Easy maintenance... reliable... and silent... are others. **Siemens Impact on Non-Impact Printing Technology.**

Siemens research and development efforts in printing technology not only created the ND-2 Laser Printer, but has produced the first truly practical low-cost ink-jet terminal printer in the industry. **Ink-Jet Printing. Fast and Silent.**

In seeking to design the ideal printer, we sought more than simple speed and economy. We also concentrated on human engineering. A reduction in noise levels. And we succeeded in all three areas. The Siemens-developed Ink-Jet Printing mechanism works on the vacuum principle and attains a top printing speed of 270 incredibly quiet characters per second on untreated paper in a script that is highly legible, smear proof, and indelible.

All you hear is the rustle of paper. And you **never** have to replace the Print Head.

To prove these points to yourself and know more about the strengths of Siemens and their family of Computer Peripherals, contact us at:

Siemens Corporation
OEM Division, 1440 Allec Street
Anaheim, California 92805
(714) 991-9700



Responsive products from a responsible company.



CIRCLE 143 ON READER CARD

Autohook

That's all it takes to connect the Extel R/O teleprinter to the switched telephone network.

Because we've replaced conventional external interface equipment with an integral modem that includes FCC registered line access circuitry all the way to the telephone line.

This means that with no more external signal hardware than a telephone connecting jack, the Extel R/O printer can receive a call, answer the call, and send its own answer back (up to 63 characters), all with-

out human intervention—automatically.

And you don't have to deal with several companies to complete the installation. One technician can do it during one call.

Internal Integrated DAA/DLC. It's another example of technological leadership by Extel, a pioneer in self-state

teleprinters, expandable dot matrix printing, internal memories, automatic dialing and integral selective calling systems.

Learn more about Extel's complete line of modular, programmable teleprinters. Contact Sales Dept.: Phone (800) 323-5470, Telex 72-4393; TWX 910-683-4782, or use the coupon.

You'll get the best connection in teleprinters.

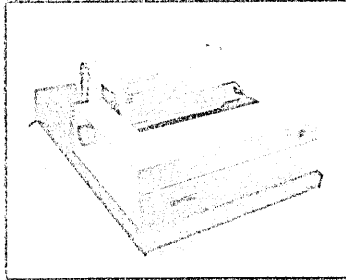

EXTEL
Being first is our business.™

Extel introduces the most advanced hookup system in the teleprinter industry.

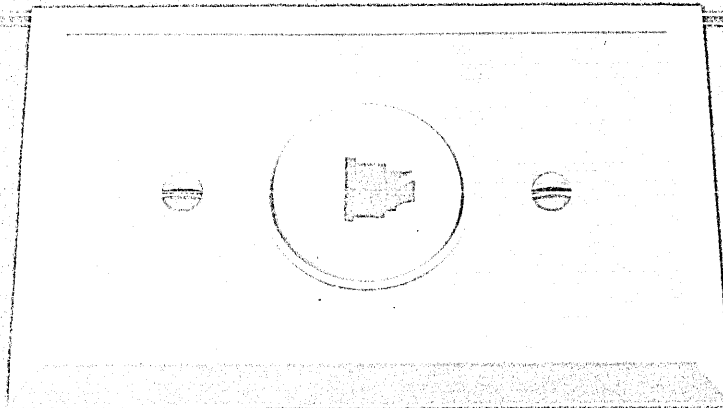

Extel Corporation/310 Anthony Trail/Northbrook, Ill. 60062
Please send me complete details about Extel teleprinter, s.

NAME _____
COMPANY _____
ADDRESS _____
CITY _____
STATE _____
ZIP _____

The bank's top management decreed that the move into word processing would provide better service, save money, and be well worth the trauma.

CONSIDER THE BANK OF AMERICA

by Howard Anderson

When the Bank of America couldn't hire enough qualified secretaries in 1974, it began in a big way to move into word processing, then a new phenomenon in the office environment. The prime motivation was to increase secretarial productivity and stretch secretarial talent further. Today, hundreds of word processing units later, the bank finds that one of its most difficult chores is, again, personnel—how to find enough trained word processing operators.

One word processing trend that has surfaced at the Bank of America is that secretaries and former secretaries don't tend to make good word processing operators. Because of the relative tedium of word processing, the work seems better suited, for instance, to former keypunch operators.

Actually the seeds of the problem began in 1971, when the bank spent \$7 million for secretarial typing support; by 1974 that cost had escalated to \$25 million and the bank's management, concerned that the situation could get out of hand, decided to do something about it.

At the same time, like many other organizations, the bank was facing the problem that productivity had increased little while the cost of operating the bank had increased dramatically. The classic answer to the productivity problem would be to hire more people, but that would mean more salaries, more rental space, and more associated expense. Further, the bank was looking at a clerical wage rate that was increasing 10% to 11% a year.

It is interesting to note that increased managerial productivity was not a factor in the bank's early thinking on the issue. Later, however, managerial



Says Bank of America's Neil Jackson, "A terminal of any type on the desk of a senior manager at the bank probably wouldn't work . . . he has to have something simple and invisible, something where he pushes one button and he gets what he wants."

productivity became the fulcrum in selling the concept of word processing, particularly when cost justification became an issue.

Neil Jackson, an assistant vice president at the Bank of America, says: "One of the things that made word processing cost effective was that we had large enough locations to do our testing. We have over 60,000 employees. Our Pasadena center has 1,800 employees and turns out 120,000 letters per month; our San Francisco center has somewhat fewer people, but still turns out 95,000 letters per month.

"If you are a small organization or a small company, you aren't going to save very much money, if any, by putting in word processing. You have to have a big enough concentration to be able to put the resources on the task."

One of the marching orders from top management was that this fledgling word processing department should provide better service and save money. Moreover, Jackson tells of an executive vice president who very patiently explained that just providing better service and saving money wasn't worth it—the trauma of implementing a new system was such that it didn't make sense if the bank ended up where it started or just slightly ahead.

FROM HERE TO THERE

In a large company, expertise in an area such as word processing should not be located everywhere; it is more prudent to have a concentrated number of experts within the bank who can serve as internal "consultants" to the rest of the bank on matters such as word processing.

Under the direction of a senior-level vice president, experts from the word processing group—called the Word Processing Feasibility Group—get "invited" in to various divisions of the bank at the division's request. In other words a division may call on the experts if it perceives a need. Because there may be some real difference between what the division's managers consider a "need" and what the employees in that division see as a need, the feasibility group must tread lightly.

In 1974 there were two analysts assigned at the bank concerned with word processing; now there are nearly 200 analysts, supervisors, and other operators.

The feasibility group first conducts lengthy interviews with the department that sought its assistance. These interviews include everyone from the managers to the word originators,

the secretaries, and sometimes even photocopier operators. The goals of these interviews are twofold: first, to find out what the department did and how it did it (information that was necessary to build an effective questionnaire); and, second, to begin to gain the confidence of the users, managers, and executives.

However, even the best solution isn't worth much unless it's implemented; generally, the feasibility group won't run the risk of coming up with solutions which everyone agreed with in principle but which won't work in a practical sense for one reason or another. Once this is understood, the study group moves ahead.

After the initial interviews, a specific questionnaire is developed for the department that requested the study. Typical questions asked in, say, a lending department environment are:

■ Is the current secretarial support adequate for your needs? (Typical answer: Yes 58%; No 42%.)

■ How do you input material for typing? (Typical answer: longhand 98%; dictation 2%.)

■ What is the most frequent cause for retyping? (Typical answer: typographical errors 78%; misunderstanding input 22%.)

A Global Processing Network

The Bank of America, the world's largest commercial bank, is currently developing a global word processing network with operations offices on five continents. There are presently over 200 Lexitron 900 and 1000 wp's dispersed throughout the bank's offices; many of these machines are equipped with asynchronous communications. Documents can be transmitted from a text to the bank's computer system. Communications are now on-line to Los Angeles, San Francisco, New York and Chicago. Offices in Houston, Europe, Asia and South America are in various stages of planning and testing.

The development of a communicating word processing system was fueled by the bank's rapidly expanding international operations, and the need for closer coordination and control of transactions. Also, since

worldwide transactions are often complex and lengthy, the ability to transmit entire documents quickly is an important asset.

The use of communicating word processor systems began in early 1977 with links between San Francisco, Los Angeles, and Chicago. The bank standardized on Milgo modems. The system is up and running with transmission rates of 300cps.

Neil Jackson, an assistant vice president at the bank, is emphatic about the importance of electronic mail to the bank. Uses include transmission of credit applications and other transaction data, as well as memoranda that will enable executives in different cities to confer on major decisions with more complete information.

Future plans at Bank of America include expanding word proces-

sing to its nearly 1,100 California branches. To accomplish this, plans are being developed that could tie wp's to an existing on-line computer network. The bank is presently testing an OCR system, and preliminary results look promising; it will be hardwired directly to a Lexitron unit. In addition, the San Francisco wp center already has a photocomposer installed, and that will soon be linked to the communicating word processing network, allowing documents from all over the country to arrive electronically to be photocomposed.

Also under development are extensive switching systems that will enable facsimile terminals, central files, data terminals, and other devices to fit into the network. Management terminals to complement the centralized dictation and wp systems are also being considered. *

And then the bank turned its attention to managerial productivity and discovered a major justification for the system.

■ Are your deadlines usually met? (Typical answer: Yes 88%; Yes, but must be retyped due to errors 9%; No 3%.)

■ Are there any activities that you currently perform that can be performed by the secretarial staff? (Typical answer: Yes 27%; No 73%.)

■ Do you have any suggestions? (Typical answer: improve quality of typing 22%; improve telephone reception 23%; improve photocopy service 28%.)

Next, these questionnaires are processed and the results presented to the management of that department. The comments are also included. Activities are listed and the questionnaire is specific as to the number of days this task is performed and the number of minutes that it is performed over a weekly period. For example, the activity "handwritten correspondence" may take 11% of a typical day and represent an "equivalent staff" of 7.7 "people."

Now these "people" aren't clerical or secretarial staff, they are \$25,000 to \$35,000 per year managers and executives. And it was this that forced Bank of America to look at managerial productivity, since improving on "handwritten correspondence"—often a management activity—would have a major effect on cost justification. As it turns out, much more savings can be realized in managerial productivity savings than in cutting out one or two secretaries. All this, however, is not an easy task, since proving to top management that these kinds of savings are legitimate can take considerable time.

MOMENT OF TRUTH

Finally, the moment of truth arrives: The Word Processing Feasibility Studies Group must "sell" its recommendations to the user group.

The problems here can be severe. How are the "savings" realized? Does the bank lay off the secretaries? Or does the bank give early retirement to those extraneous loan officers? Luckily, the bank has a policy of not laying people off, and normal attrition usually is sufficient to "slim down" a department within a reasonable period. The feasibility group attempts to get a commitment—in writing, no less—that the department will not add more people when it increases its workload.

This is also the philosophy expressed by Robert White (April 1977, p. 83) of Citibank in New York. The Citi-

bank argument is slightly more complex but its aims are similar to those of the Bank of America. Citibank says that normal (employee) growth rate shows that the bank will grow from 49,000 employees to 55,000 over the next six years, and that the typical current ratio of managerial control is seven subordinates to every supervisor. If, Citibank philosophy goes, it were possible to substitute sufficient office automation hardware for people, that span of control could increase from 7:1 to 9:1. That means the bank could do 15% more business with no increase in staff.

With a potential labor cost savings of \$35 million annually and a potential hardware cost of \$10 million, the proposition is intriguing. Citibank is still experimenting and it is too soon to tell whether the bank has been entirely successful. What is intriguing is that Citibank and Bank of America have arrived at the same destination from different points of departure.

Now there is a new problem: What are managers going to do with the extra time? And how can management productivity be measured? One solution is to gradually increase the workload of managers, raise their span of control, and simultaneously make available the technology that can allow them to handle the workload. Further, as part of their ongoing evaluation, these managers can be graded on both how well they can handle their increased workload and how well their subordinates can handle *their* increased workload.

For example, a manager we know has 500 people reporting to him in a \$1.5 billion dollar minicomputer company. Previously he had an "open access" arrangement where anyone could call or drop by his office with a problem. Some days he did little but put out fires.

Now he insists that such "problems" be transmitted to him on the firm's recently acquired computer-based electronic mail system. He now can make the decision himself about what is important and what is not important. Further, he has told his people that their performance rating will depend on how well they adapt to and adopt this new technology. The executive spends one hour a day at his electronic mail terminal and he swears that it is the most productive hour he has every day. His number of phone calls has decreased and his amount of real work, he says, has dramatically increased.

But the minicomputer company executive is unusual. Most executives view keyboards as they view the bubonic plague. Office automation for them will begin and end outside their office doors.

The Bank of America's Neil Jackson says, "A terminal of any type on the desk of a senior manager at the bank probably wouldn't work. He has to have something simple and invisible, something where he pushes one button and he gets what he wants."

Jackson goes on to say that the results with the bank's word processing effort so far, even with the basic system, have been encouraging. Savings for the last three years, after all expense items, were pegged at \$4.5 million and the bank expects the savings to be \$6 million in 1978. Not all of those are hard dollar savings; some are cost avoidance or "soft savings" and the results have proved so fruitful that the bank is studying the next phase of automation.

For example, a loan application from South America must be approved by the bank in San Francisco before it can go on the books. The mails and even the bank's time-sharing network are too cumbersome. But by having compatibility of word processors and electronic communications, that load can quickly be sent directly to San Francisco, approved, the modifications made, and retransmitted to South America. For a \$20 million dollar loan, the estimated savings of five days could possibly represent increased revenue to the bank of \$25,000. And it is exactly that kind of \$25,000 manna from heaven that makes it all worthwhile. *

H. ANDERSON



Mr. Anderson is the president of the Yankee Group, Cambridge, Mass., a consulting firm specializing in the communications area. He has recently completed an analysis of AT&T's Advanced Communications Service and has written previously for DATAMATION on the subject of IBM's computer and communications strategy. Mr. Anderson is a graduate of the University of Pennsylvania and the Harvard Business School.



The reason Epoch 4 has made it to the top in the Netherlands is because it deserved to.

Quality. When you have it, the world finds out fast.

When you're moving into the future as fast as the Netherlands, you use a lot of computer tape. And you quickly find out which ones deliver and which ones don't.

When Graham introduced Epoch 4

several years back, we promised a tougher tape, a fully certified tape, a tape that would guarantee more throughput, and less downtime and overtime.

And we've delivered on those

promises. So much so that we've delivered millions of reels of Epoch 4 all over the world.

Epoch 4 is the patented one. The one that's proven itself through billions of passes.



GRAHAM MAGNETICS *Proven around the world.*

Graham, Texas 76046

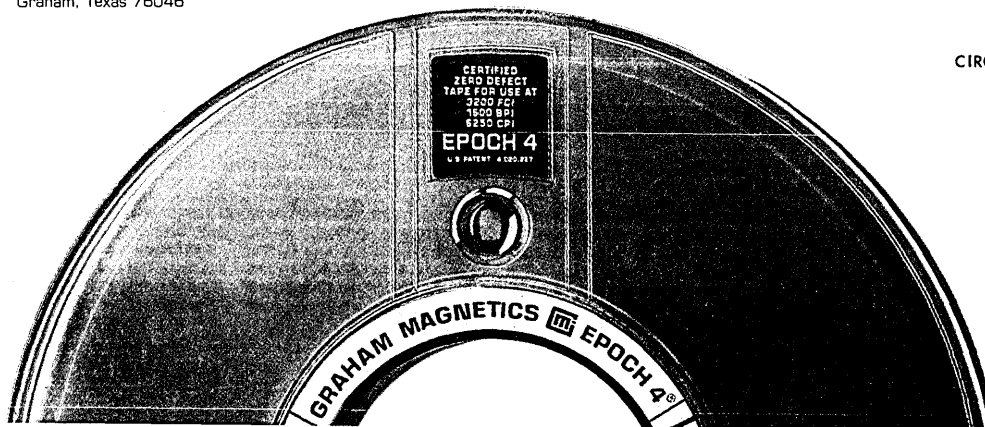

CIRCLE 44 ON READER CARD

The Portable Cost Saver.

for newspaper reporters



for field diagnostics

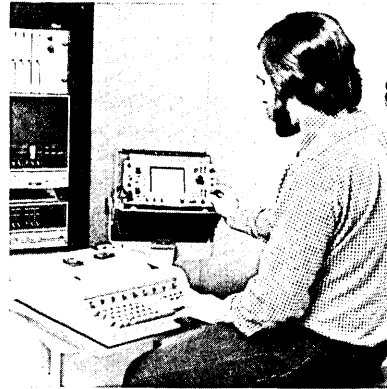

for sales representatives



for programmers

CDI has conceived the smartest move yet for terminal users . . . the Miniterm 1205 *Portable* ASR!

Incredibly, in one compact package the 1205 offers a portable, micro-processor-based terminal with removable storage media and off-line editing capabilities that rival some of the most sophisticated word-processing systems.

Users can now rely on a small, rugged terminal that packs a quiet printer with *both* an integral 8K Random Access Memory and a built-in Mini-Cassette tape unit with up to 68,000 characters of removable storage.

And when it comes to great moves . . . a salesman, programmer, field technician or journalist can go anywhere, plug the Miniterm 1205 ASR into an ordinary wall outlet, and communicate with any popular CPU via the built-in acoustic coupler.

Because you can prepare, edit and format data off-line where it is generated, and you no longer must store programs in an expensive, time-sharing medium, you can substantially reduce both telephone line charges and program storage costs. In fact, in some cases, Miniterm 1205 ASR's can pay for themselves with savings better than three-to-four times the monthly rental charge.

Get the flexibility — plus real savings — that only CDI offers. The Miniterm 1205 *Portable* ASR. Make it your smartest move yet.

The most versatile portable ever offered!

- Built-in Mini-Cassette tape transport with removable storage of 68,000 characters per Mini-Cassette
- Integral 8K Random Access Memory, expandable to 32K, with powerful high-speed editing capability
- Quiet, buffered, 50 CPS thermal printer
- Unique, three-mode keyboard (APL optional)
- Built-in Acoustic Coupler
- Portable Carrying Case

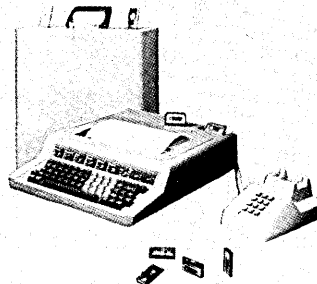

COMPUTER DEVICES INC.

25 North Avenue
Burlington, Ma. 01803
(617) 273-1550

SALES AND MAINTENANCE OFFICES THROUGHOUT THE U.S. AND CANADA.

NOBODY CAN MANY WAYS AS

At Dataproducts, we not only build the world's finest printers, we also build the broadest line of printers in the business.

So if your job requires Dataproducts quality (and we've never seen a job that didn't) you can bet there's a printer in our line-up that'll fit right in.

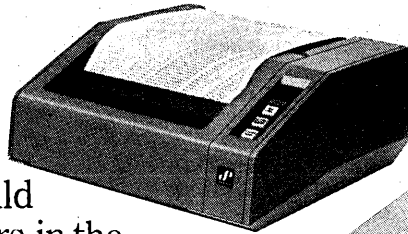

T80 THERMAL
PRINTER—80 CPS

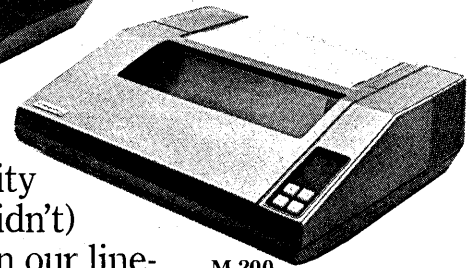

M-200
MATRIX PRINTER
200 LPM

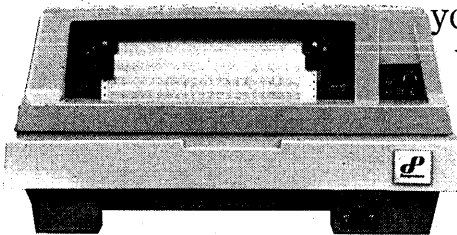

B-300 BAND PRINTER
300 LPM

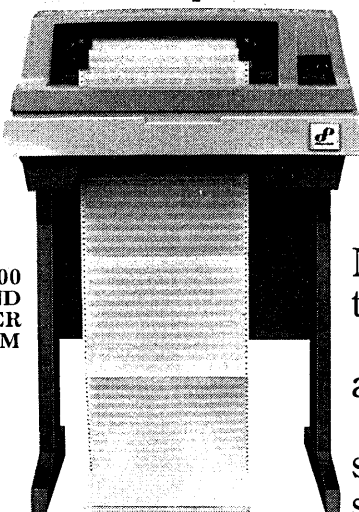

B-600
BAND
PRINTER
600 LPM

Just scan the page and you'll see: We make serial printers. And we make line printers. Thermal printers. And matrix printers.

We make drum printers. And we make band printers. We make quiet, inexpensive machines that work at 80 CPS. High-speed workhorses of 1500 LPM. And a whole range of speeds in between.

We have printers for every purpose. Civilian or military. Small business systems. Message terminals. Machine-readable applications. And high-volume EDP.

Altogether a varied and versatile lot.

But for all their diversity, Dataproducts printers share one trait in common:

Reliability. The same stubborn, steadfast, tenacious, dependable quality that has made our printers the standard of the industry.

And we back up that built-in dependability with a system of in-depth support for our

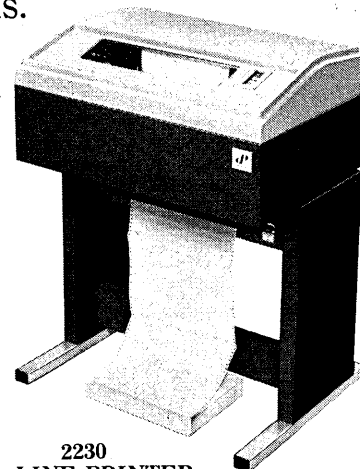

2230
LINE PRINTER
300 LPM

SAY PRINTERS AS DATAPRODUCTS.

2260 LINE PRINTER
600 LPM

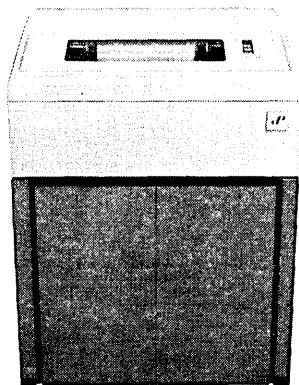
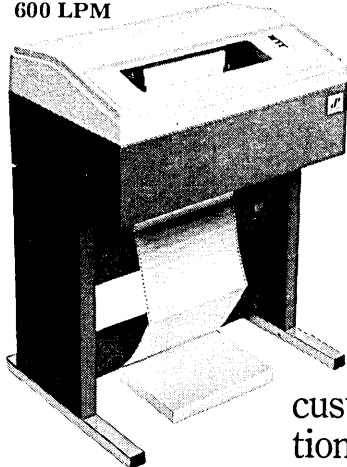

2290 LINE PRINTER
900 LPM

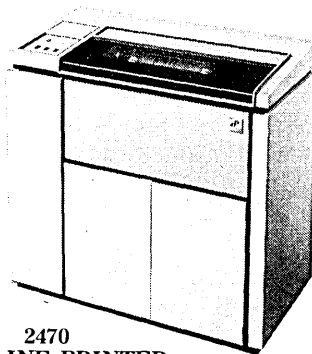

2470
LINE PRINTER
1250 LPM

2550
CHARABAND PRINTER
1500 LPM

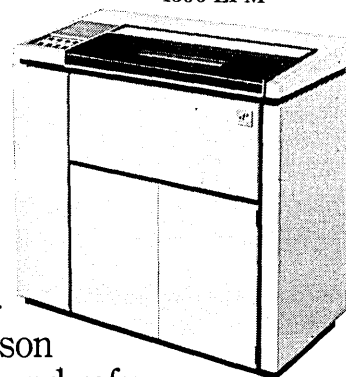

customers. Fast, efficient spare parts distribution. Technical support and training. Field liaison and technical documentation. Repairs and refurbishment. And printer supplies such as ribbons for all types of printers.

As a result, nearly 400 computer manufacturers include Dataproducts as original equipment. Making us the largest independent printer company on the planet.

Whatever your needs, wherever you are, Dataproducts is there to serve you. We have factories in the United States, Ireland, Hong Kong, Puerto Rico. And offices around the globe.

When you need printers, look to Dataproducts first. You probably won't have to look anywhere else.

TEMPEST
LINE
PRINTERS
300, 600 &
900 LPM

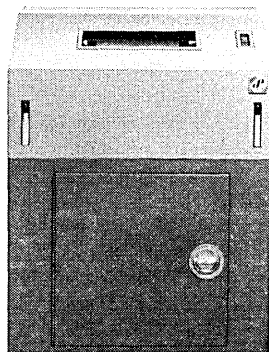

2910
MILITARIZED
PRINTER
356-1110 LPM

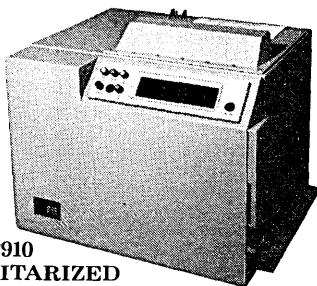

MXT-1200
MESSAGE PRINTER
320 CPS

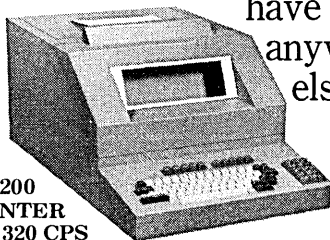

THE PRINTER COMPANY

Call or write for your nearest Sales Office or Distributor. 6219 DeSoto Ave., Woodland Hills, Ca. 91365. Tel: (213) 887-8451
Telex: 67-4734/Darmstaedter Landstrasse 199, Frankfurt, W. Germany. Tel: 681-034, Telex: 841-416344.

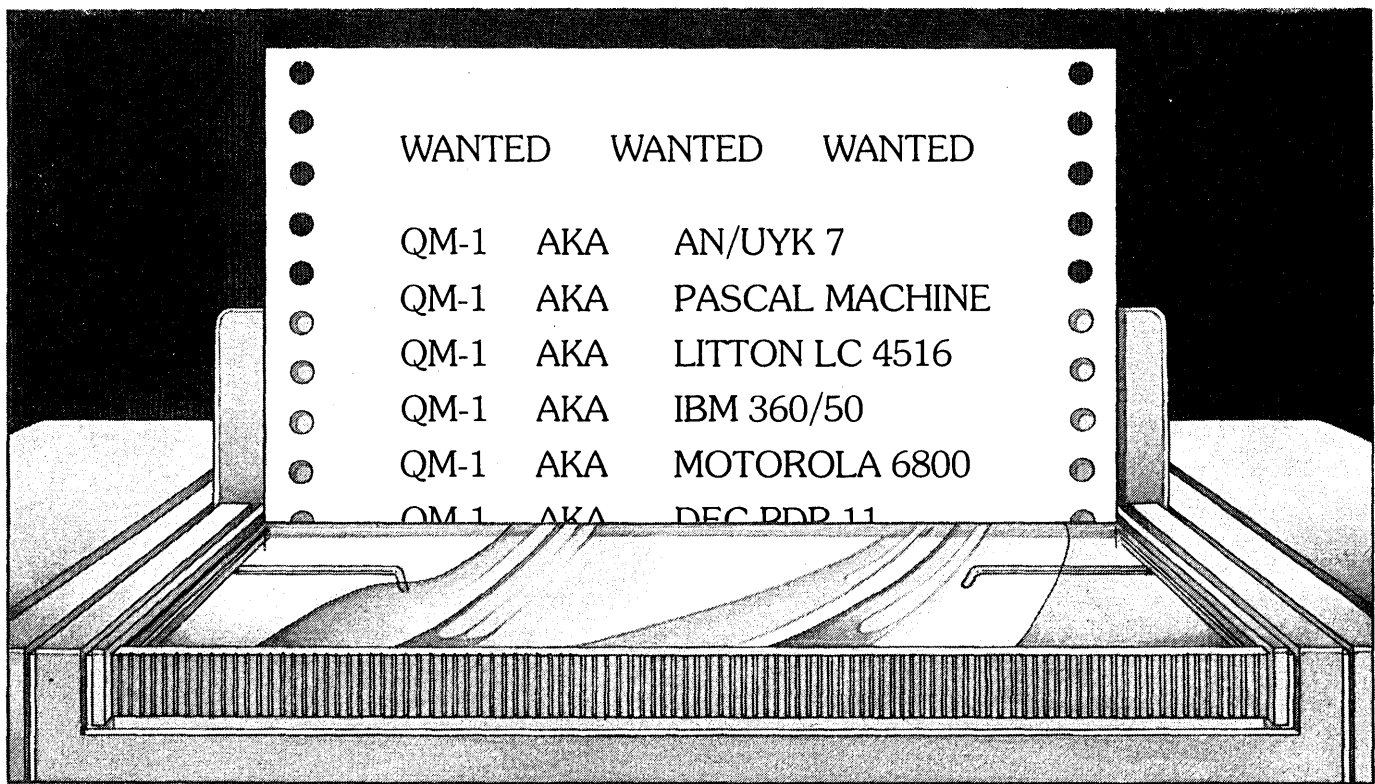

The QM-1 Also Known As The Emulator

The "computerhunt" for a single machine that can service a wide range of needs in a development laboratory ends with Nanodata's QM-1, The Emulator. The QM-1 can assume the identity of any computer, becoming exactly like the emulated machine down to the most minute detail.

Software developed on the QM-1 will run unchanged on the emulated machine and vice versa. What is more, the QM-1 can change identities as often as the user chooses.

Challenges that the QM-1 has met include digital design verification, critical

software validation and hardware/software trade-off analysis. Whatever the specific computer requirements — general purpose, avionic, military, minis, imbedded micros or HOL machines — the QM-1 can satisfy them.

A typical QM-1 configuration costs approximately \$300K. A cost-effective investment considering that emulators on the QM-1 have been benchmarked at speeds 35 to 100 times faster than simulators on multi-million dollar systems.

Talk to Mike Senft, Marketing Director, about specifics.



NANODATA CORPORATION

2457 Wehrle Drive, Williamsville, New York 14221

Telephone (716) 631-5880

WHO DOES THIS PRINTER THINK IT'S KIDDING?

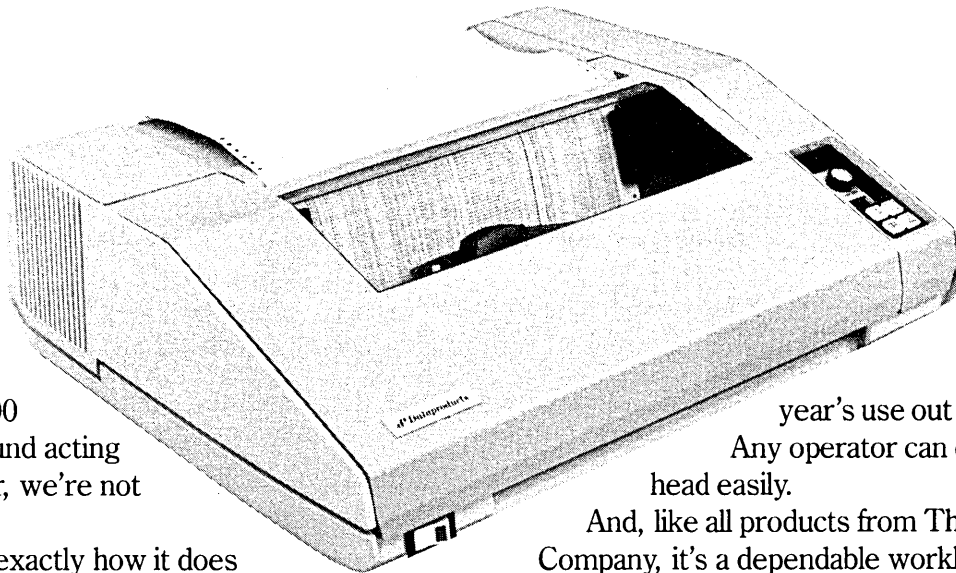

If the M-200 wants to go around acting like a line printer, we're not about to stop it.

And that's exactly how it does behave, cranking out an effortless 200 lines per minute, average throughput.

But the truth is, the M-200 is a serial printer. Which should certainly be obvious from the extremely reasonable purchase price of about \$2000. (In OEM quantities.)

And so, if the M-200 delivers performance that can fool you, blame it on its design features.

Like our revolutionary 14-wire, dual-column print head, for instance. The design combines the flexibility of a single head with the speed and long life of multiple heads. (You can expect more than a

year's use out of the head.) Any operator can change the head easily.

And, like all products from The Printer Company, it's a dependable workhorse. Made even more so by its optional self-diagnostic system.

If something needs attention, the system tells you if you can tend to it yourself. Or if you can't, you know what to tell the serviceman. That can save him a trip, saving you down time and money.

And that's the inside story of the M-200. Acting like something it's not? Maybe. But since its delusions are all in your favor, why complain?

THE M-200 MATRIX PRINTER

THE PRINTER COMPANY



Call or write for your nearest Sales Office or Distributor. 6219 DeSoto Ave., Woodland Hills, Ca. 91365. Tel: (213) 887-8451
Telex: 67-4734 • Darmstaedter Landstrasse 199, Frankfurt, W. Germany. Tel: 681-034, Telex: 841-416344.

Nice going, DEC[®]

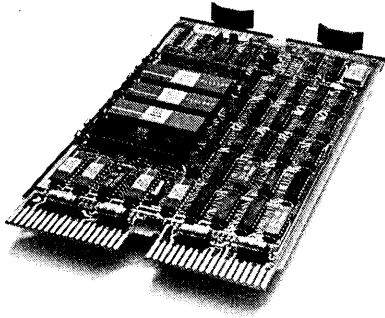

DEC's microcomputer

DEC's LSI-11/2[®] has been called the world's most powerful 16-bit microcomputer, and we wouldn't argue with that at all.

Good show, DEC.

®Registered trademark of Digital Equipment Corporation

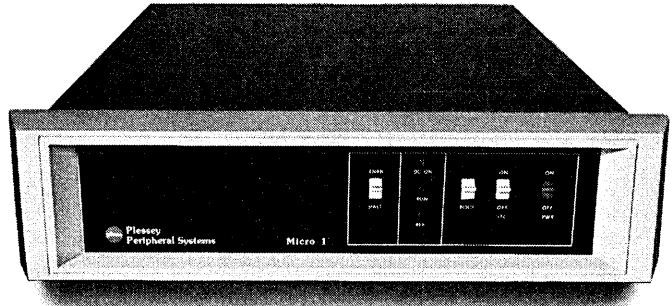

Plessey's Micro-1/03

In fact, we like DEC's micro so much that we turned it into a mini and named it the Plessey Micro-1.

The Micro-1 consists of a DEC LSI-11 combined with Plessey backplanes, memory controller and interfaces, packaged in either a 5¼" or 10½" rack-mount chassis.

The Plessey Micro-1 has the full instruction repertoire of the PDP-11/34[®] (more than 400 instructions), supported by DEC's RT11 operating systems and diagnostic software. You can mix Q bus[®] and Unibus[®] interfaces and peripherals using our Unibus to Q bus converter; use DMA from your floppies and discs; and think what you can do with the multi-level priority interrupt structure.

All this minicomputer performance is available at microcomputer prices. And we're shipping now.

Values like these have made us the largest independent supplier of DEC-compatible peripherals. Our product line presently includes add-in/add-on core and semiconductor memories, cartridge disc systems, floppy disc systems, mag tape systems, complete computer-based systems, and a wide variety of backplanes, expansion chassis, and other accessories.

We're the only real alternative to DEC, a complete single source. For all the details, please contact the nearest Plessey sales office today.



Plessey Peripheral Systems

17466 Daimler, Irvine, California 92714, (714) 540-9945

KEEPS QUIET. WORKS HARD. FOR VERY LITTLE.

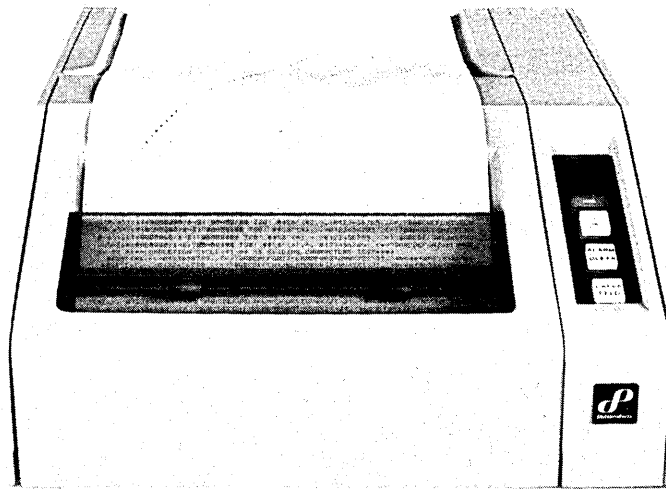

Our T-80 Receive Only printer is a quiet, unassuming sort. Doesn't take up much room on the desk. Doesn't make a racket while it's doing its work.

And it doesn't require a lot of money before it'll go to work. In fact, the T-80 runs less than \$900 in OEM quantities. And it continues to save you money with its low cost of ownership.

On top of all this, the T-80 prints fast. 80 CPS fast. Which is nearly three times faster than most other thermal printers.

All these qualities — low price, impressive speed, high quality, and quiet operation — have combined to make the T-80 an absolute natural for applications that demand silence. Hospitals. Open office situations. Testing and instrumentation.

THE T-80 THERMAL PRINTER

mechanism, with the same unique operator-replaceable print head and driver electronics, is available as a module: the T-80 M.

So, it's up to you. Buy the complete T-80 RO, ready-to-run. Or just take the T-80 M mechanism and design your own printer around it.

Either way, you save money, and the T-80 goes quickly and quietly about its business.

And the T-80 is the logical supplement to your CRT if you want occasional hard copy printouts.

Now, you don't have to buy a T-80 RO to get T-80 performance. The basic T-80

Dataproducts

THE PRINTER COMPANY

Call or write for your nearest Sales Office or Distributor. 6219 DeSoto Ave., Woodland Hills, Ca. 91365. Tel: (213) 887-8451
Telex: 67-4734 • Darmstaedter Landstrasse 199, Frankfurt, W. Germany. Tel: 681-034, Telex: 841-416344.

Buying Intelligent Terminals?

Think Ontel

Ontel terminals are more than just well-designed, flexible and reliable . . . they're low-cost total systems all sensibly engineered.

We offer powerful cluster systems. Master terminals coupled with intelligent slaves provide unique distributive processing capabilities.

Providing the software you need is a must. We offer three high level languages, forms generation, word processing, text editing, extensive utilities and diagnostics . . . all running under Ontel's Disk or Diskette Operating System.

Ontel software enables our users to reduce their development costs for a multitude of different applications.

Ontel terminals have a modular structure with up to 64K of memory and are designed for field upgrade. They're easily programmed and have a full range of controllers including communications, mass storage and printer interfaces.

Contact us today for the intelligent answer.

Edward J. Heinze
National Sales Manager

Ontel Corporation
250 Crossways Park Drive
Woodbury, NY 11797
(516) 364-2121



Word processing technology and user's needs are in flux;
system designers must provide for this change.

WHYS AND HOWS OF WP SYSTEM FLEXIBILITY

by William A. Lippold

Any user designing a word processing system today is faced with three inescapable facts: first, WP equipment technology and capabilities will continue to advance and improve; second, practically every user's needs for WP will continue to change; and third, the WP manager will be expected to meet his or her organization's changing needs for WP with the most efficient capabilities available. These three facts create a situation where the design of a good WP system is never-ending. The equipment configuration and operational procedures will undergo continuous modification and the day when things settle down will never arrive. Therefore, system flexibility, as well as price and performance, must be a primary concern in selecting WP equipment.

In most organizations, it is unrealistic to expect that anyone can accurately define the current needs for WP before the equipment is installed and used. No matter how thoroughly the current procedures are studied and how many statistics are gathered and analyzed, the actual needs are bound to be different than those anticipated. It's unlikely that the planned operational procedures will turn out to be just right, or that the productivity estimates were precise. In many cases, a system is designed around the presumed needs and then the organizational procedures modified to fit the system when it becomes apparent that the presumptions about needs were wrong. And productivity has a way of meeting expectations, rather than being maximized.

Even if some of the actual needs can be precisely defined, the application of WP to these needs is likely to change them. For example: the defined need is to reduce the time required to produce a finished document from two days to one day; once this is done, the need will be redefined to produce it in one hour. Or, once the defined need to print justified copy with variable word and letter spacing is accommodated, the new need may be to typeset it. Initially,

the organizational needs may lag behind the capabilities of a WP system, but once these capabilities become apparent to the users, their needs will soon match and then exceed them.

Therefore, a good WP system will not only be able to accommodate future

needs, it will also be able to adjust to current needs as they become known. Absolute system flexibility in this regard is impossible to achieve, but there are some things the WP manager can do in designing a system and selecting equipment that will maximize flexibility.

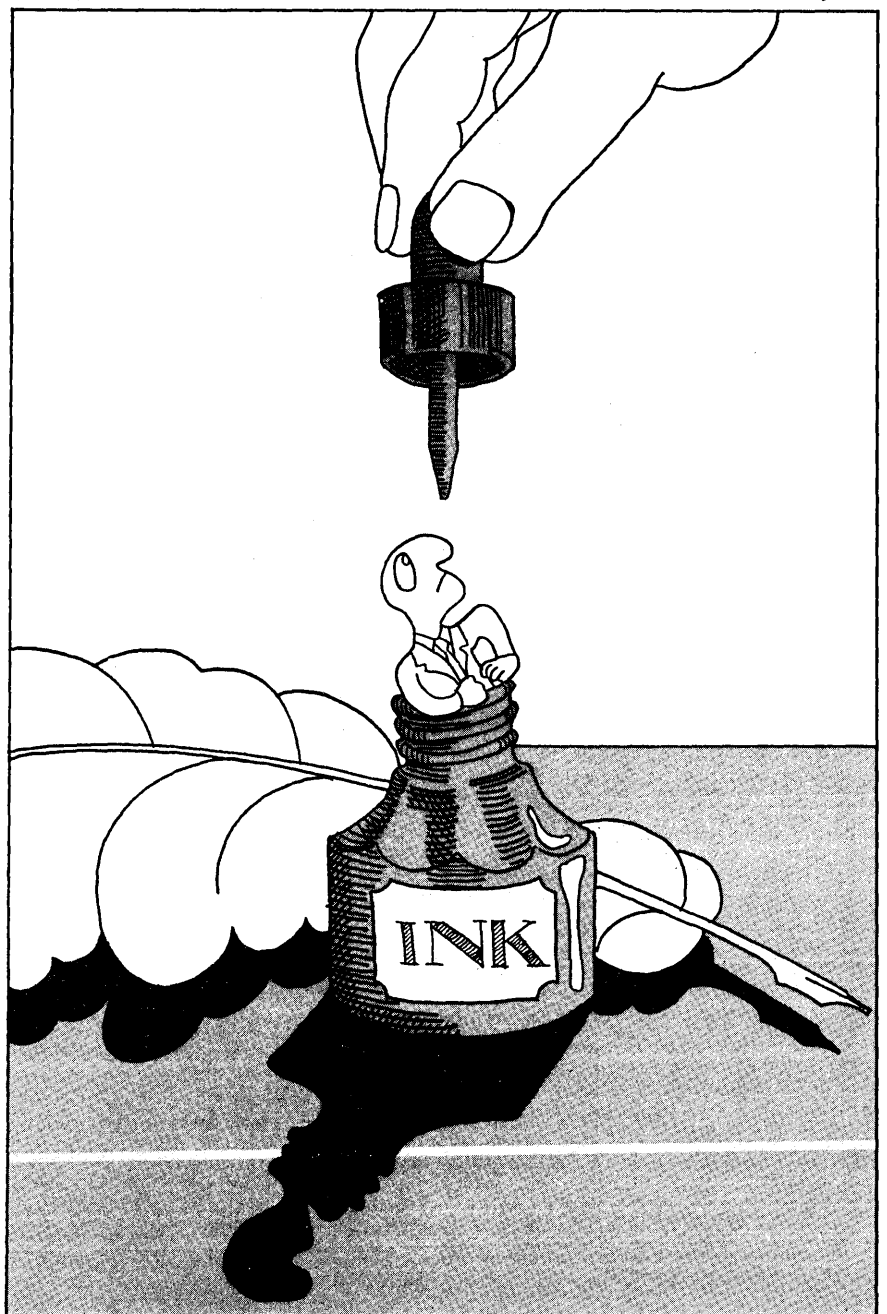

FLEXIBLE SYSTEMS DESIGN

One of these is to select an equipment supplier that has a flexible system architecture—that is, an architecture whose basic design principles enable easy expansion and change in the system's capabilities. If the supplier allows you to select from two or three printers of varying speeds and printing quality, the same system can probably accommodate the new printer that will be invented next year. And, if you can now choose between small floppy disks and larger rigid disks, you'll be able to upgrade your storage capacities in the future.

If the system is controlled by a programmed computer and you can now select various software packages, you'll probably be able to take advantage of new programs the supplier will develop in the future, without having to change your equipment. The more options the supplier offers, the more likely it is that the system can be configured, and reconfigured, to meet your exact needs as they become known. And the more likely it is that you'll be able to add new capabilities in the future as they become available.

Another factor in designing a flexible system is *not* presuming that all WP equipment will be physically located in one central location. Although you may initially want to perform all of the WP work in a single center, two or three years from now you may also want to establish satellite centers, or locate single terminals at remote sites. The equipment you select should be able to accommodate such needs, and provide the means of moving or transmitting copy among these centers and remote sites. Ideally, you should be able to reconfigure the initially centralized equipment into multiple satellite centers, or single remote stations, rather than having to buy more equipment.

Remember that implementing a centralized or decentralized WP system does not restrict you to using shared-logic or freestanding equipment. Just as the terminals and printers of a shared-logic system can be located some distance from the central controller, multiple freestanding terminals can be located together in the same location. And you can buy systems that consist of

both shared-logic and freestanding terminals.

In selecting equipment, you should also consider the need for OCR, data communications, phototypesetting, and the need to move data between the WP system and your company's computer.

Incorporating such flexibility into a WP system presents several problems to the designer. However, two of these are *not* availability and cost. Although many systems are either inflexible or of limited flexibility, there are several systems on the market that provide excellent flexibility characteristics. And there is no strong correlation between system flexibility and price. That is, systems that offer a high degree of flexibility generally cost no more than those that do not.

Designing for flexibility does, however, require more effort in the equipment selection process. More factors must be considered and more systems must be studied than if the equipment were to be selected simply to meet the designer's current presumed needs.

DEALING WITH MANAGEMENT

Perhaps the biggest problem in designing a flexible system, however, is in regard to management's attitude. Many corporate managers are unfamiliar with WP equipment and procedures. This lack of knowledge sometimes results in the establishment of attitudes and policies concerning WP that have been derived from their experience with data processing. They see the WP problem in a static, rather than a dynamic, frame of reference. For example, they may not understand why current needs cannot be precisely and quantitatively defined, they may not understand the office procedures in detail, and cannot appreciate the importance of the human element in the operation of a WP system.

Compared to the needs of a WP system, the business data processing tasks are well defined and established. Few corporate managers can remember when their payroll was not done by computer, and they haven't experienced the problems associated with automating such manual tasks. The

transition from having private secretaries typing documents and maintaining manual paper files to having these tasks performed in a WP center in electronic form is not trivial, and the best equipment and procedures to perform these tasks in an automated manner cannot be precisely defined. The extent to which office procedures can and should be automated will depend upon the unique needs and environment of each company and will be strongly influenced by personal preferences.

Someday the design of a WP system may be as straightforward and quantitative as replacing or upgrading a dp system is today. But until then, WP systems must be capable of evolving toward an organization's needs as they become known. This requires flexible WP equipment, but more importantly, it requires an understanding on the part of corporate management that a gradual transition will be required, that the justification for installing WP equipment may not be as quantitative as with dp equipment, that mistakes in planning and system design will be made, and that the problem of automating office procedures will require his attention and the organization's resources for an indefinite period. *

WILLIAM A. LIPPOLD

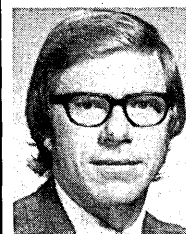

Mr. Lippold is the president of Harvard Associates, a Harvard, Mass. consulting firm specializing in word processing, electronic editing, automated composition, and typesetting systems. During his more than 17 years in the industry he has held various engineering, product planning, and management positions with IBM, Honeywell, Digital Equipment Corp. and ECRM. Much of that experience was in the design of computer hardware and software, and in managing projects that required significant changes in work methods, personnel, and organizational structures.

Free LSI-11[®]

Buy Dataram's exciting new
BULK CORE MINI
 with as little as 256KB of memory,
 and you'll get an LSI-11 with the
 power of a mini (...and the LSI-11 is free!)

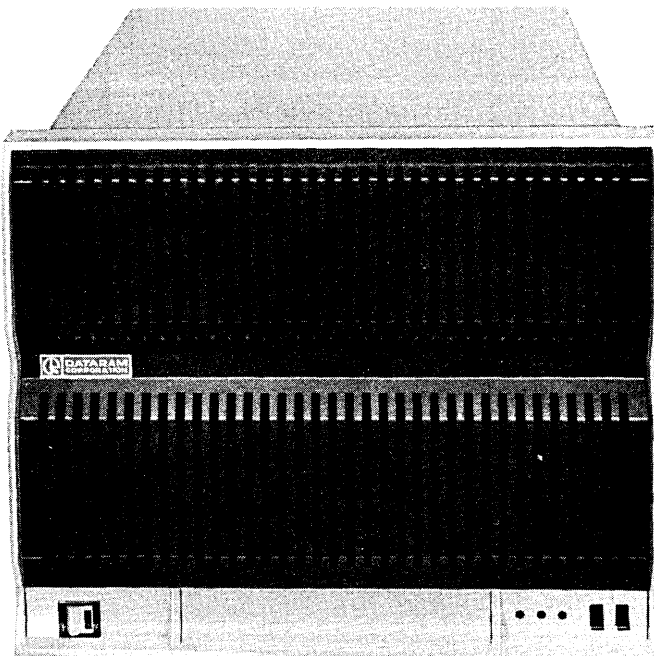
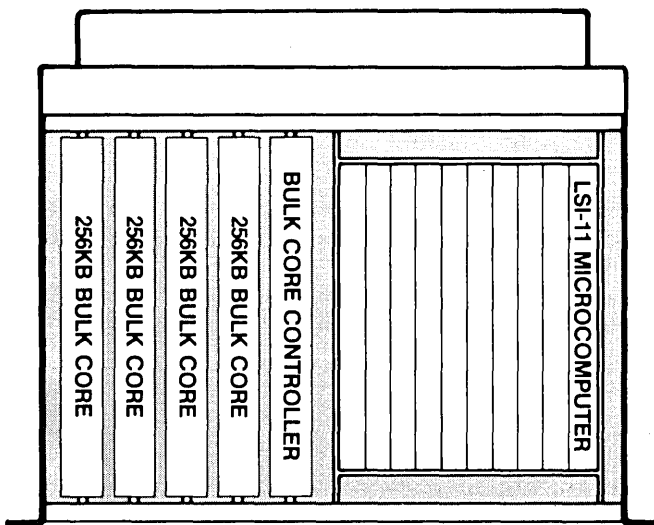

Introducing the **BULK CORE MINI**, simply the most innovative idea in anyone's memory. From Dataram Corporation, the people who pioneered BULK CORE for disk emulation. And are now combining BULK CORE with DEC's LSI-11 in a new **BULK CORE MINI** — BCM-1. Buy our **BULK CORE MINI** with as little as 256KB of memory, and we give you the LSI-11 at no charge!

In addition to one megabyte of BULK CORE, the BCM-1 has ten DEC quad slots available to accommodate the LSI-11, main memory, and peripheral controllers.

The BULK CORE in the BCM-1 emulates fixed-head disk via the BULK CORE controller, and is completely transparent to the LSI-11. Offering access times thousands of times faster than FHD systems, and, because it's all electronic, with much more reliability.

1.0 megabyte **BULK CORE MINI**

BCM-1 chassis (includes power, blowers, and BULK CORE controller)	\$ 3,200
(4) 256KB BULK CORE modules (\$4,800 ea.)	19,200
(1) 32K x 16 semiconductor main memory	1,800
DEC LSI-11 microcomputer (no charge)	--
	\$24,200

.5 megabyte **BULK CORE MINI**

BCM-1 chassis (includes power, blowers, and BULK CORE controller)	\$ 3,200
(2) 256KB BULK CORE modules (\$4,800 ea.)	9,600
(1) 32K x 16 semiconductor main memory	1,800
DEC LSI-11 microcomputer (no charge)	--
	\$14,600

Dataram manufactures the core and semiconductor ADD-INS for the LSI-11, which can be used with the BCM-1.

Get the power of a minicomputer with an LSI-11, and use it for process control, disk-swapping applications, multi-terminal, or multi-programming installations. Or a wide range of other applications.

DEC and LSI-11 are registered trademarks of Digital Equipment Corporation.



PRINCETON-HIGHTSTOWN ROAD
 CRANBURY, NEW JERSEY 08512
 TEL: 609-799-0071 TWX: 510-685-2542

France: YREL, 33-9502224 • Italy: Mactronics Italia, 35 36 041 • Spain: Aupoca, 34-1-4575312 • Sweden: M. Stenhardt AB, (08) 739 00 50 •
 Switzerland: ADCOMP AG, 01/730 48 48 • United Kingdom/Ireland: Sintrom Ellinor Ltd, 44-734-85464 • West Germany/Austria: O.E.M.-Elektronik GmbH 49-711-798047/48 •
 Australia/New Zealand: Anderson Digital Equipment, 61-3-5432077 • India: Industrial Electronic Instruments, 79281 • Israel: Integrated Systems Ltd., 921513 •
 Japan: Matsushita Electric Trading Co., Ltd., 81-3-4354552 • Taiwan/Republic of China: Syscom Computer Engineering Co., 02-7026284/85.

You've made your career in dp. And then one morning your company asks you to manage the word processing function. Now what do you do?

THE NEW WORD PROCESSING MANAGER

by Randy J. Goldfield

While top management is usually familiar with the data processing environment, it is frequently unaware of the scope and impact word processing (WP) may have on its organization. As a result, a candidate to fill the WP manager's position may be selected without giving proper consideration to the unique responsibilities of the job.

Because word processing is still a new field, qualified word processing talent is still scarce and, in many cases, even requisite managerial specifications do not exist. Too often this lack of awareness and necessary in-house expertise can ultimately lead to the complete failure of the WP system.

Given the lack of widespread managerial expertise in WP, the question arises: Is it possible to prevent such a costly—and sometimes embarrassing—breakdown from happening? The answer is "yes," but it is a qualified "yes." The chances for success increase only as management's knowledge and expertise in WP increases.

As in data processing, the three key elements of word processing are equipment, procedures, and people. But unlike data processing, successful managers in word processing agree that procedures and personnel are the most important aspects, despite the "sex appeal" of technology. Word processing equipment takes a back seat to the other two elements. This is explained by the fact that users were titillated by WP gear when it first appeared in the late 1960s. As experience with WP grew, it became apparent that the gear worked fine, but there were often problems with the *personnel* who operated it, and the *procedures* that were supposed to rule it.



Managing the delicate balance among the three components differentiates the word processing manager's job from the data processing manager's job. To illustrate this, consider the following case history:

Five years ago, a company implemented a word processing system and appointed a manager with data processing but no word processing experience. For our purposes here, we shall call him Harry. Over a period of time, Harry had developed a good rapport with his users and his peers; he had more than 10 years'

service with his firm; and he had established a solid foundation in data processing technology. However, Harry lacked some very important knowledge and skills.

To begin with, Harry was unaware of the rapidly changing use and application of word processing equipment and concepts. For example, his data processing orientation gave him a tendency to favor minicomputer shared logic systems over less sophisticated standalone systems. He also lacked essential secretarial managerial skills.



Leasametric rents I/O terminals for all your short-term requirements.

From a day to a decade.

Now you can rent the latest CRT terminals, teleprinters and protocol monitors by the day, week, month or longer. Choose the datacomm equipment you need from the world's largest and most diverse rental inventory of telecommunications equipment. Top manufacturers like Teletype, Texas Instruments, Lear Siegler, DEC, Hewlett-Packard, Diablo, GE and Hazeltine. We even stock the newest IBM 3270 plug-compatible units from Courier and Telex!

Nationwide service facilities.

All equipment is inventoried and serviced by rental specialists at Leasametric's 24 regional Inventory Centers across the U.S. and Canada. There's one near you to guarantee quick turn-around during emergency situations.

In the event of a failure, we'll replace malfunctioning equipment with a fully-operational unit

within hours. You deal directly with Leasametric's applications engineers and technicians who are geared to respond to your emergency problems quickly and efficiently.

Only one monthly charge.

When you rent from Leasametric you pay just one low monthly rate. There's no extra installation/take out fee, no add-ons, no monthly maintenance or repair costs. We take care of everything.

Call your nearest Leasametric Inventory Center today for immediate delivery of the latest CRT terminals, teleprinters and protocol monitors. Ask for your FREE EDP Equipment Rentals brochure outlining our many services and programs.

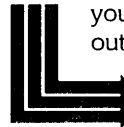

Leasametric

Division of Metric Resources Corporation
1164 Triton Drive, Foster City, CA 94404

INVENTORY CENTERS: San Francisco, CA (415) 342-7111; Los Angeles, CA (213) 768-4200; Anaheim, CA (714) 634-9525; San Diego, CA (714) 565-7475; Houston, TX (713) 988-1000; Chicago, IL (312) 595-2700; Boston, MA (617) 272-6520; Midland Park, NJ (201) 444-0662; Long Island, NY (516) 293-5881; Washington, D.C. (301) 881-6700; Orlando, FL (305) 857-3500; Dayton, OH (513) 898-1707; Philadelphia, PA (215) 583-2000; Denver, CO (303) 429-7900; Minneapolis, MN (612) 854-3426; Dallas, TX (214) 661-9193; Atlanta, GA (404) 491-1155; Seattle, WA (206) 455-3080; Baltimore, MD (301) 444-5144; Kansas City, KS (816) 474-2280; Phoenix, AZ (602) 258-1225; Norfolk, VA (804) 627-4411; Toronto, Ontario (416) 676-1897; Syracuse, NY TBA.

The Data 100

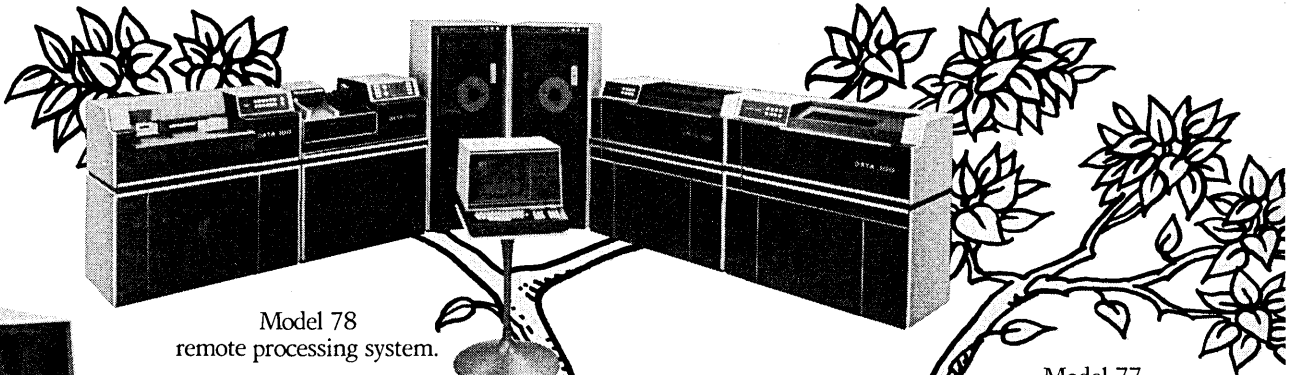

Model 78
remote processing system.

Model 77
communications system.

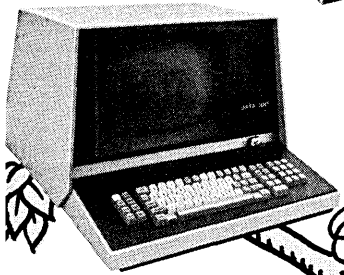

Model 82
remote display system.

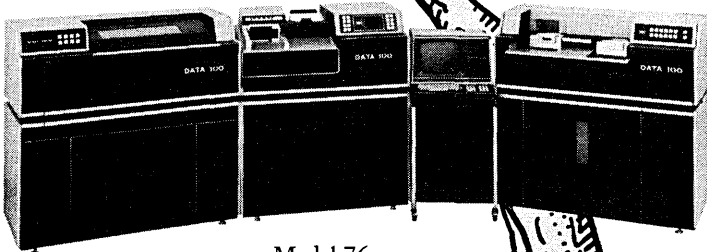
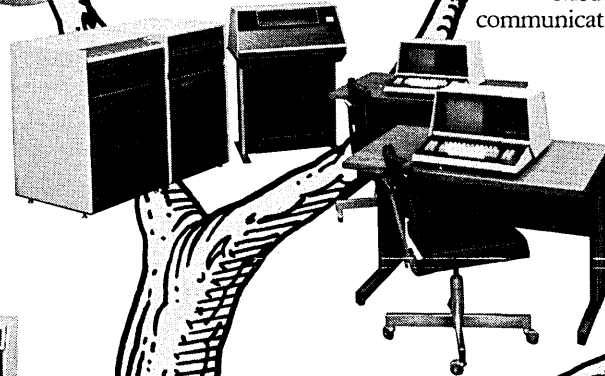

Model 76
remote batch terminal.

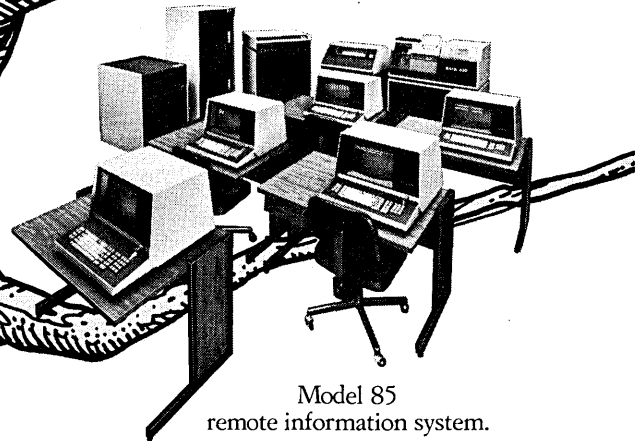

Model 85
remote information system.

multifunction data processing

family tree.

Our family tree is rooted in a sound concept.

Multifunction data processing.

Data 100 products perform multiple functions operating in networks, using a variety of communication disciplines over a wide range of user applications.

Whether your requirements call for remote job entry, data entry, remote or local file management, stand-alone processing, or any combination of these, you're looking at a family of products that can answer your needs.

Our Model 76 provides the best in RJE emulators and peripherals.

Model 77 data entry concurrent with communications can be disk or diskette based.

Keybatch systems feature key-to-disk data entry on 20 MB disk storage, plus networked entry stations and printers.

Model 82 emulates IBM 3270 on-line file management functions.

Model 78 combines all of the above functions and adds stand-alone processing with disk or tape RPG.

And, at the trunk of our multi-function system is the Model 85 Remote Information System. It offers a multitasking operating system, file management using up to 100 MB disk storage, stand-alone processing using COBOL and RPG, and total connectivity with other Data 100 products.

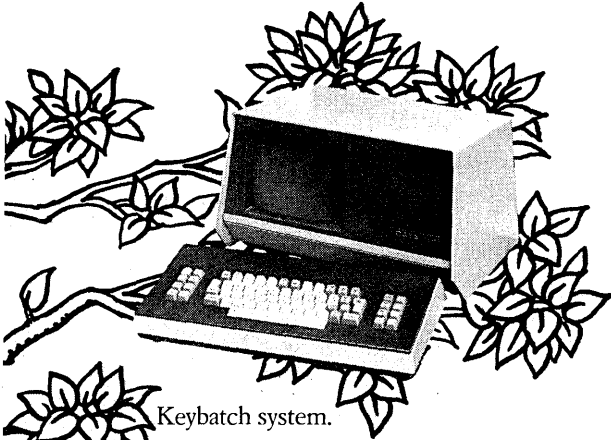

Keybatch system.

DATA 100
CORPORATION

multifunction data processing

We keep growing to cover your growing needs.

LOS ANGELES 213/645-4300 • SAN FRANCISCO 415/546-6000 • CHICAGO 312/992-0850 • BOSTON 617/848-6100 • DETROIT 313/358-5065 •
MINNEAPOLIS 612/941-6500 • NEW YORK 212/867-6200 • PITTSBURGH 412/391-5425 • HOUSTON 713/784-4130 • WASHINGTON D.C. 703/790-5560 •
WOODBIDGE N.J. 201/634-7800 • ATLANTA 404/455-3895 • ST. LOUIS 314/878-4911 • TORONTO 416/494-0434 • MONTREAL 514/761-5894 •
LONDON ENGLAND (05827) 63161 • MELBOURNE AUSTRALIA (03) 267-3544 • FRANKFURT GERMANY 72-04-71 • PARIS FRANCE 630-2144

CIRCLE 37 ON READER CARD

EASYTRIEVE relieves the information bottle-neck

Do you get information from the computer when you want it? Every time? Without delay? Or does your data center strain to get the information you request and so vitally need to make decisions?

EASYTRIEVE is a well-proven solution to relieving the information bottleneck.

EASYTRIEVE is the information retrieval software system from Pansophic that requires no coding forms, no complex machine language. EASYTRIEVE works with simple, English key words to produce reports from the computer as fast as the machinery can move. EASYTRIEVE is simple to learn and to apply, yet can be the basis for entire job accounting systems, EDP audit procedures, modeling and financial systems . . . the list is endless.

Call us today toll free to find out how EASYTRIEVE users around the world are managing through current, reliable information.

EASYTRIEVE. The award-winning software solution in use at over 1,500 IBM 360/370 data centers across the globe. From the people at Pansophic. Offices near you throughout the world.

PANSOPHIC

709 Enterprise Drive, Oak Brook, IL 60521

800-323-7335



In one extreme case, the center received a memo requesting typing service scrawled on a cocktail napkin. The center supervisor was incensed.

was unfamiliar with secretarial tasks, and unaccustomed to dealing with secretaries. His firsthand experience or knowledge of the office environment was limited because the data processing department was very different from most "offices" in the company, and his training and personnel development skills in the office environment were weak. In addition, neither he nor upper management responsible for his appointment anticipated the significant differences in the intensity and scope of user/management liaisons between a word processing center and a data processing department.

In this case, the resistance to change from prospective users precipitated by the conversion to a word processing center was massive. Unlike most data processing application installations, the changeover was not looked upon by users as a system to aid or improve their efficiency, but regarded suspiciously as something new and therefore dangerous. And, unlike data processing conversions, word processing, by reorganizing, reassigning, and reducing secretarial staff was viewed by many professionals as a direct infringement on their domain and a detriment to prerequisites they had heretofore enjoyed. Their dissatisfaction was shared by the participating secretaries who feared that the diverting of their typing and dictation responsibilities indicated that their jobs had become obsolete.

In addition, the professional caliber of word processing center staff was so different and also so much less sophisticated than the data processing staff, that Harry was not able to relate to their personal and professional needs.

Accustomed to a work environment in which the user's needs were dependent upon the technical capabilities of the hardware and the high level technical expertise of staff, Harry was unprepared to interface with both user demands and his own word processing staff's sinking morale.

Users who had been previously indulged by private secretaries were not properly educated in formal center capabilities and procedures. As a result, they had unrealistic expectations or were unaware of and unconcerned with methods of document input and protocol. In one extreme case, the center received a memo requesting typing service scrawled on a cocktail napkin. Not only was the center supervisor incensed by this apparent lack

WP MANAGER CRITERIA	Typical EDP Skills Relationships
<ul style="list-style-type: none"> • Data Analysis Skills • Systems And Procedures Development • Financial Planning • Creativity • Management Skills • Top-Management Interaction Skills • Personal Qualifications • State-Of-The-Art Knowledge In Word Processing And Office Environment • Widespread User Liaison Skills • Training Skills For Users And Secretaries • Secretarial Development Skills 	<div style="display: flex; flex-direction: column; align-items: center; gap: 10px;"> <div style="display: flex; align-items: center;">●</div> <div style="display: flex; align-items: center;">●</div> <div style="display: flex; align-items: center;">●</div> <div style="display: flex; align-items: center;">◐</div> <div style="display: flex; align-items: center;">◐</div> <div style="display: flex; align-items: center;">◐</div> <div style="display: flex; align-items: center;">◐</div> <div style="display: flex; align-items: center;">○</div> <div style="display: flex; align-items: center;">○</div> <div style="display: flex; align-items: center;">○</div> <div style="display: flex; align-items: center;">○</div> </div>
<div style="display: flex; align-items: center; gap: 20px;"> <div style="display: flex; align-items: center;">● <i>Strong</i></div> <div style="display: flex; align-items: center;">◐ <i>Varies Individually</i></div> <div style="display: flex; align-items: center;">○ <i>Weak</i></div> </div>	

Fig. 1. The dp professional who moves into the word processing environment brings a variety of previously acquired skills to the new job. To be successful however, the manager must learn other skills that are unique to the word processing world.

of consideration, but the user also became understandably indignant by the lack of cooperation and handling he felt he was receiving. Before the implementation of the center, he had never encountered any difficulty with his private secretary. Now, he was having nothing but trouble.

Meanwhile, many members of the remaining administrative secretarial staff who did not work in the center resented the word processing center, and did their best to sabotage the facility. Work destined for the center was left on desks and submitted at the end of the day to sabotage turnaround time. Calls from the center were not returned and administrative secretarial errors were blamed on the center staff.

CRISIS OF CONFIDENCE

He saw it as childishness, and he left the bewildered center supervisor to handle it. Unable to present a clear picture of the complexities of a word processing system or to fully understand his new

role vis-a-vis the users and his staff, Harry failed to gain the confidence of either group.

The company also managed to compound the problem by failing to support Harry in his new role while never really allowing him to acquire and develop appropriate skills through either internal and professional group efforts or through outside training programs.

As one would expect from such a situation, center productivity started to drop substantially while typing errors became increasingly frequent. Center secretaries with good skills felt unappreciated and tried to leave the center at the first opportunity. Those who remained, having the poorest skills and therefore no alternative, developed morale problems, often quarreling among themselves. Considered by outsiders to be the worst position in the company, no secretary would bid for a replacement position.

Users, of course, continued to complain about the poor service. The fatal blow occurred when one department discontinued using the center altogether, insisting upon the return of its

The word processing staff is sometimes overawed by technology

private secretaries. Management wondered what went wrong.

MANAGERIAL SKILLS

The whole unhappy situation is not traceable to the incongruity of a dp background with wp management: there is really no reason a data processing professional cannot convert to a word processing managerial position successfully and capitalize on the added benefits of his technical expertise. He must, however, possess the qualifications necessary to ensure smooth operations in the unique word processing environment and be aware of and prepared to deal with the differences between the two. All these qualifications are not inherent in the dp environment. The essential criteria for word processing facilities management combine new and previously acquired skills.

Managerial skills can be developed through proper training and understanding of people. Leadership, decision-making ability, and sound judgment are universal managerial elements. The word processing manager must also possess an understanding of

secretarial as well as professional and word processing staff needs, and be capable of motivating staff and dealing with users accordingly.

Skills for training users and secretaries must be developed by the word processing manager to orient users and train secretaries in methods and procedures, equipment capabilities, and language arts reinforcement. It is important during training seminars to stress what the system can and cannot do so that the center receives input that it can accommodate. Unlike the data processing environment, word processing staff is sometimes overawed by technology and fearful or reluctant rather than curious about it. The effective word processing manager is aware of this syndrome and deals directly with these problems.

In addition, there are other key areas of expertise that a good wp manager should develop. Consider the following:

Personnel development skills including the ability to construct proper job descriptions and career pathing programs are pivotal to the development of full staff potential. Typically, word pro-

cessing personnel need a great deal of development and very often no job description other than "secretary" exists. wp management must acquire realistic aspirations and an understanding of secretarial objectives before enlightened programs can be created.

Top management interaction skills can be evidenced best through meaningful communication with top management with a focus on how its original goals are being achieved, whether they be cost reduction, cost avoidance, or improved service.

Financial planning entails budget handling, long term planning, and projecting the company's secretarial support staff requirements. Most data processing professionals possess these fundamental skills and need only to adapt them to the secretarial environment.

Data analysis skills are important; maintenance of standards and implementation of required changes can be accomplished only after accurate data and statistics have been gathered. Here, most data processing professionals have great strength and can provide creative, useful methods for handling historical

Oppenheimer & Co., Inc.

Introducing our 1978/79 Key Issue Conference Series

Wall Street research takes the measure of issues likely to have important bearing on companies and users in the computer/communications industries. We invite you to attend the first Oppenheimer & Co., Inc. conference on the information industries which is opened to the public. Let the advance agenda outlines speak for themselves.

Concise Full Day

AT&T's Advanced Communication Service

Insights into AT&T's rationale, and expectations for ACS...

— William P. Stritzler,
Marketing Director,
Cross-Industries, AT&T

Competitive assessment of ACS in context of SNA, alternate packet services...

— Lawrence G. Roberts,
Chairman, Telenet

Analysis of industry response and reaction to ACS...

— Key regulatory official

Tuesday, Oct. 3 — New York City
Wednesday, Oct. 4 — Chicago
Thursday Oct. 5 — San Francisco

panel of prominent users will react to each speaker's comments

luncheon speaker — Henry Wojtyla,
Oppenheimer economist & VP

presentation of results of SNA migration survey and PCM buyer profiles

\$125 inclusive
\$200 after Sept. 22

for full information & registration:
(800) 221-5833
(212) 825-8988 collect

IBM's Plug Compatible Mainframe Competition

1980 IBM architecture, software, technology...

— James K. Dutton, VP Mktg.,
Amdahl

PCM mainframe vendor & user decision making...

— Bert Hochfeld, VP,
Telex Computer Products

PCM Wall Street perspective and analysis...

— Gideon Gartner, VP,
Oppenheimer & Co., Inc.

RENT NOW!!

I/O Terminals — Month-To-Month

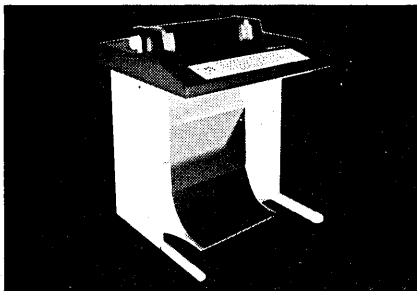
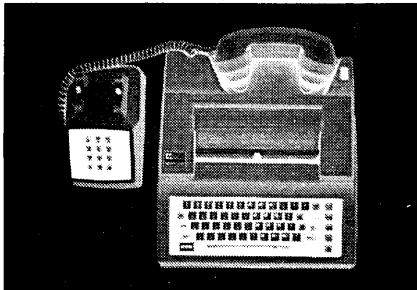
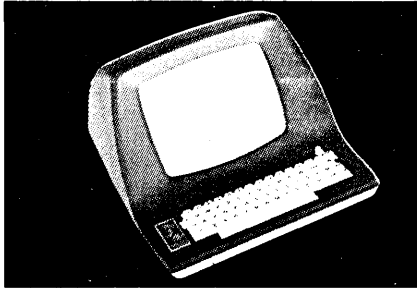

CONTINENTAL RESOURCES has the world's largest inventory of computer peripherals ready to fill your rental needs. CRT's, teleprinters, portable data terminals, and the latest model of data monitors from such top manufacturers as DEC, Lear Siegler, Texas Instruments, Teletype™, Hewlett-Packard, and Spectron. All are available for weekly, monthly or yearly rental.

CONTINENTAL is geared to respond and support your peak loads, crash programs, or emergency requirements. With nationwide inventory and service centers, staffed with more than 100 professionals, we can provide you with the equipment and service you need, when you need it, and for as long as you want it.

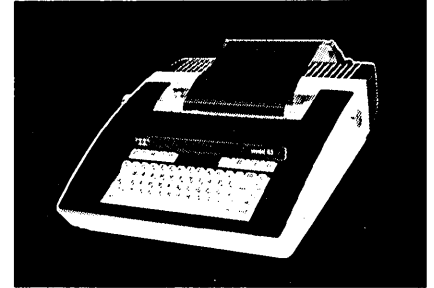

Rent with confidence from **CONTINENTAL!** You're backed by:

- top manufacturers
- immediate availability
- one monthly charge
- in-house service
- no down time

CALL CONTINENTAL's nearest inventory center now. Find out how you can rent these CRT's, teleprinters, portable data terminals, and data monitors for a week, a month, or a year.



CONTINENTAL RESOURCES, INC.

175 MIDDLESEX TPK., BEDFORD, MA. 01730

Inventory Centers: Boston, MA (617) 275-0850, New York, NY (212) 695-3206, Long Island, NY (516) 752-1622, Philadelphia, PA (609) 234-5100, Scotch Plains, NJ (201) 654-6900, Baltimore, MD (301) 948-4310, Washington, DC (301) 948-4310, Atlanta, GA 800-638-4050, Fort Lauderdale, FL 800-638-4050, Chicago, IL (312) 439-4700, Dayton, OH 800-323-9656, Houston, TX 800-323-9656, Seattle, WA (408) 249-9870, Santa Clara, CA (408) 249-9870, Los Angeles, CA (213) 638-0454, Santa Barbara, CA (805) 653-1696, Costa Mesa, CA (714) 540-6566, San Diego, CA (714) 292-0750.

There can be a happy ending. Harry was replaced by a candidate with better qualifications. But we wonder what's become of Harry.

data and making systems adjustments based on findings.

If the person a firm has in mind for the word processing manager's position is going to be transferred from dp and does not meet all of the criteria of a good word processing manager, there are many ways in which these skills can be learned and developed.

Many colleges and universities offer word processing courses as well as special business degree programs for employed people, like part-time and summer programs. In addition, many larger firms offer seminar programs in word processing concepts, manuals and procedures writing, management skills, effective time management, spoken and written communications skills, staff training methodology, and creative problem solving.

Junior colleges and adult education programs offer a wide range of self-development programs including assertiveness training, dictation and speech courses, career counseling, and business psychology aimed at enhancing interpersonal skills.

Finally, many vendors offer word processing training programs. Vendors

not only have some excellent training courses, but some offer management training as well. Do-it-yourself packages for feasibility studies, cost justification, and center diagnostics are available from some vendors. Also, vendor salesmen and market support representatives are constantly in the marketplace and can be a great source of new ideas.

Obviously, Harry, the new manager in our case study—and his situation was not that unusual—met few of these criteria and was unwilling or unable to change. Fortunately, however, there can be a happy ending. Harry's company eventually reassessed its position and realized that it had made a mistake. They quickly replaced Harry with a candidate with better qualifications. With the importance of people more clearly recognized and accounted for, the new manager went on to establish training programs for both staff and users alike, while instituting incentive programs and formal center procedures.

Productivity began to climb steadily, while the center developed into a closely-knit family at the same time. Then one day an administrative secre-

tary requested placement in the center. It was the miracle of miracles, but at once everyone realized that the situation had improved. Gradually, the overall attitude of users was transferred from one of hostility to one of respect. Today, that installation is considered to be a model of how a word processing center should be operated. *

RANDY J. GOLDFIELD



Ms. Goldfield is a senior associate in the administrative management services group of Booz, Allen & Hamilton. She specializes in word processing systems studies, including feasibility, diagnostic and implementation planning. Prior to joining Booz, Allen, Ms. Goldfield spent four years as an independent WP consultant. She has also been employed by Redactron Corp. as a customer education and support manager.

If you're looking at financial systems now... and find that your needs are broader than most of today's software packages... We should talk GFS

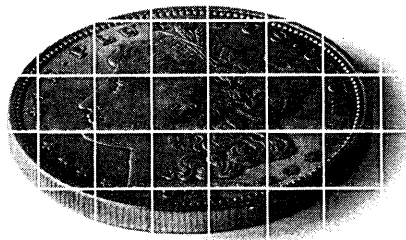

GFS is a financial system development tool—a set of integrated software modules for performing the data processing functions common to all financial applications.

Proven, flexible, highly efficient . . . we use GFS in our computer service center to implement and maintain hundreds of clients' financial applications. GFS leverages our staff, as it can yours, by cutting in half the effort needed to build a financial system, and by two thirds the effort to maintain it.

Consider a fully integrated, on-line financial system without limitations or restrictions on end user requirements . . . compatible within IBM and mini-computer based environments, all with operating efficiency. And with nationwide support from American Management Systems, the nation's largest builder of fully integrated custom financial systems.

We should talk GFS.



. . . currently in use in 75 different locations for over 200 custom financial applications

For more information, call or write:
AMERICAN MANAGEMENT SYSTEMS
1515 Wilson Blvd. • Dept. 120-1
Arlington, VA 22209
Attn. Mr. Peter Livengood
(703) 841-6000

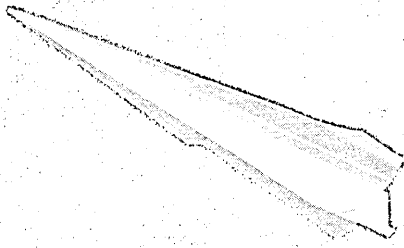

TRANSMISSION:
 Page; Field; Modified
 Field; Prompted
 Transmission; Device
 Status; Function Keys

INTERFACE:

Q/A RS-232; Current
 Loop; 17 data rates
 (switch selectable)
 including 19, 200
 characters; Half duplex;
 support line
 terminal characters;
 Reverse channel

**EDITING
 FUNCTIONS:**

Insert/Delete line and
 character; Column
 shifting; Cursor
 Addressability; Cursor
 Sense; System Only
 fields; Security fields;
 Break Variable;
 Character fields

OPTIONS:

Buffered Printer
 Interface (RS-232
 and parallel);
 separately
 addressable from
 the CPU;
 Standard Paging;
 Paging

VIDEO:

Normal; Reverse;
 Blink; Low/high
 intensity; Underline

KEYBOARD:

Removable; edit;
 state with international
 character layouts



When it comes to flexibility, the Infoton 400 Data Display terminal can hand you all you need.

Designed around the Z-80 microprocessor, it offers complete control of all Blocking and Editing functions through software settable modes. One thing that's especially easy to handle about the I-400 is that it's the most versatile terminal you can get your hands on for the price.

More information on the I-400 is quickly within your grasp. Call Infoton toll free today at (800) 225-3337 or 225-3338. Ask for Barbara Worth. Or write Barbara Worth today at Infoton, Second Avenue, Burlington, MA 01803. We have offices throughout the United States, Canada and Europe. In Canada, contact Lanpar Limited, 85 Torbay Road, Markham, Ontario, L3R 1C7. (416) 495-9123

Created by Chickering/Howell Advertising, Los Angeles

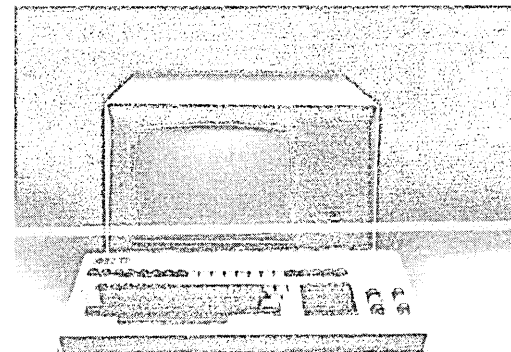

INFOTON 400

**NO
SINGLE
BUSINESS
COMPUTER
HAS ALL THE
ANSWERS.**

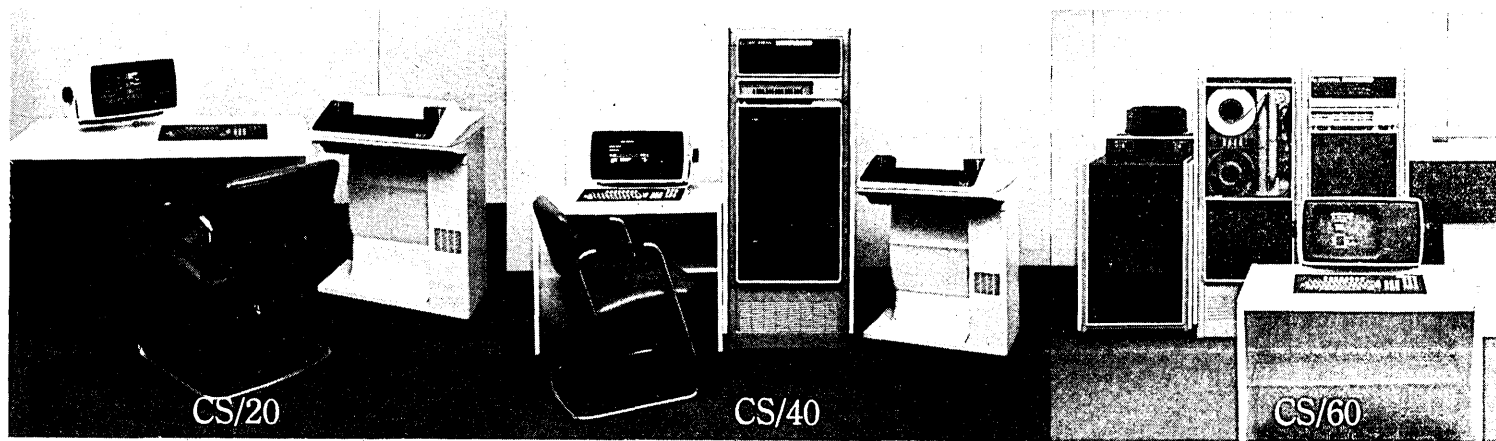

NOW, WHAT'S YOUR PROBLEM.

One of Data General's family of new small-business computers can answer your problems. They're designed to quickly and easily process your billings, accounts payable, accounts receivable, sales analysis, purchase analysis, inventory control and payroll with management information on demand.

We began with the introduction of CS/40, a mid-range business system which accommodates up to nine operators. Now it's joined by the CS/20, an entry level, stand-alone system and the CS/60, a higher capacity business system with up to seventeen clustered or dispersed terminals.

They're simple to operate and fully capable of expanding right along with your company. They all use the same Interactive COBOL software, so your investment in software is protected. And, if you need help with your applications, there is a group of experienced Business System Suppliers to assist you.

For more details on how to solve your business problems, fill out the coupon and we'll introduce you to the family.

My immediate problem is that I need more information about Data General's CS Family. Send the brochure.

I'm an: End User Business System Supplier I'm too busy to wait for brochures; have someone contact me.

Name _____

Title _____

Company _____

Tel. No. _____

Address _____

City _____

State _____ Zip _____

Mail to: Data General Corporation,
Westboro, MA 01581

DM978

 **Data General**
We make computers that make sense.

Data General Corporation, Westboro, MA 01581, (617) 366-8911 Data General (Canada) Ltd., Ontario Data General Europe, 61 rue de Courcelles, Paris, France, 766.51.78. Data General Australia, (03) 89-0633. Data General Ltda., Sao Paulo, Brazil, 543-0138 Data General Middle East, Athens, Greece, 952-0557. © Data General Corporation, 1978.

We the leader.

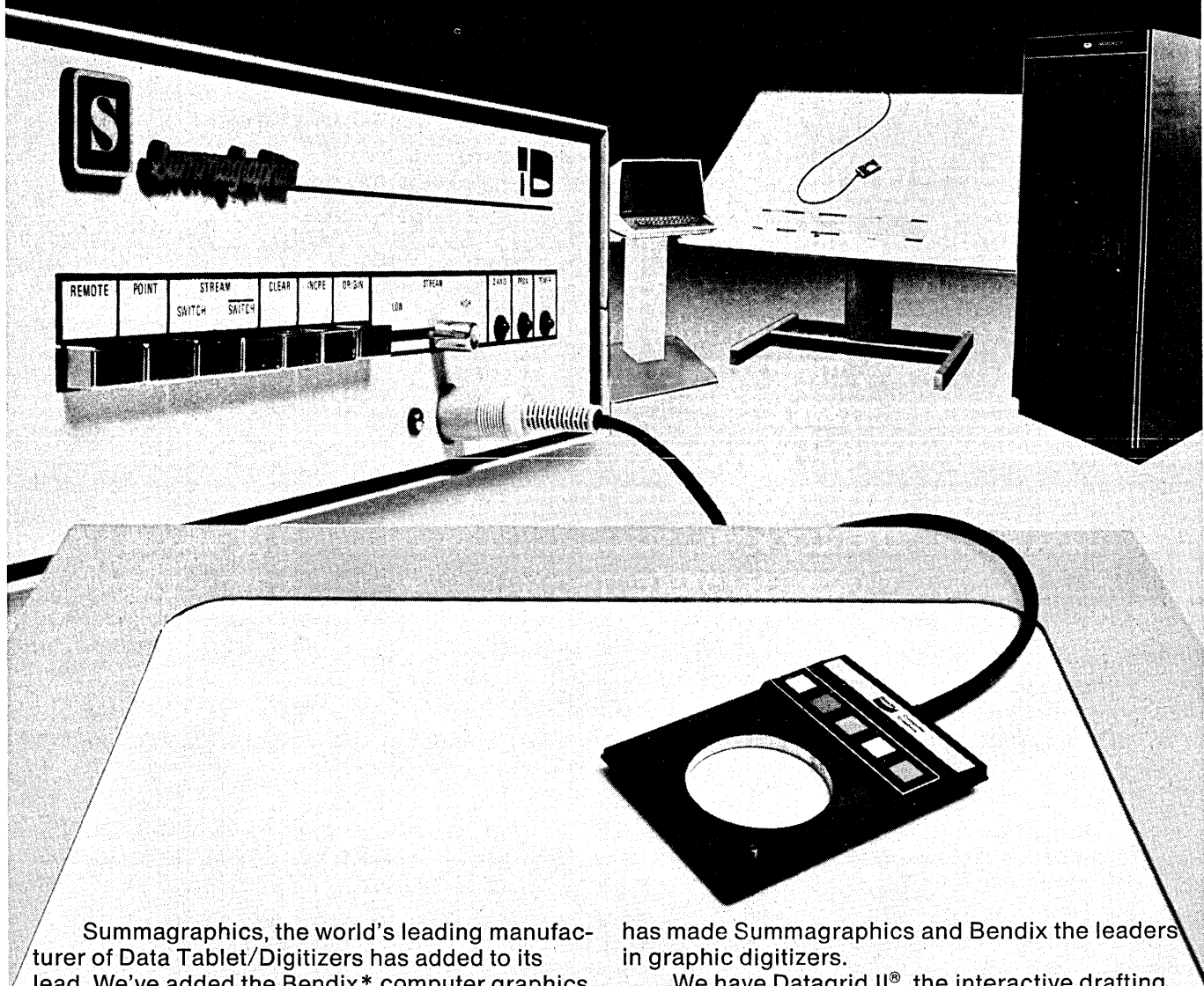

Summagraphics, the world's leading manufacturer of Data Tablet/Digitizers has added to its lead. We've added the Bendix* computer graphics line of products; renowned for high accuracy and resolution.

We now offer the largest, most complete product line of digitizers for all your graphics applications. Whether your application is in drafting, cartography, circuit design, geophysics, land management, medical research, molecular modeling or other applications, we make the high quality digitizer for all your computer graphics needs. Digitizers with ultra-high accuracy and resolution. Digitizers with back-lit capability. Digitizers built with the reputation for quality and experience that

has made Summagraphics and Bendix the leaders in graphic digitizers.

We have Datagrid II®, the interactive drafting system and ID, the Intelligent Digitizer with built-in microprocessor controls. We even have Bit Pad™, the low cost digitizer for personal computing and small computer systems.

What was once a choice in digitizer manufacturers is now a decision. Summagraphics, the decision thousands of satisfied customers have made.



Summagraphics
corporation

35 Brentwood Ave., Box 781, Fairfield, CT 06430
Phone (203) 384-1344. TELEX 96-4348

*Bendix computer graphics products are now manufactured and serviced by Summagraphics Corporation.



Buy the first page, get the second one free.

Our new smart terminal, the ADM-31, features a full two-page display as standard equipment. Not as an option. And its low cost and high reliability tell you it was made by those same people who make the world-famous Dumb Terminal™. But the 31's similarity to the Dumb Terminal ends with its dependability and rugged, proven case.

THE ADM-31 PROVES DUMB IS ONLY SKIN DEEP.

The ADM-31 is completely self-contained, with full editing, formatting and protected fields capabilities. And equipped with keyboard, control logic, character generator, refresh memory, and interface. Not to mention a micro-processor which increases reliability and ease of use. You can even order it with a printer port option, and get printouts along with your readouts.

And the 31's behavior modification gives you a factory installed

personality for an alternate ESC sequence lead-in — in addition to the standard ESC. And End Block character. A New Line character sequence. A field separator. And even a function sequence preamble.

THE ADM-31 IS ALL KEYED UP.

The ADM-31's 91-key solid-state keyboard is integrated with the main logic, and can generate all 128 ASCII characters. And it features an integral numeric key pad, with period, comma, tab, minus and numerals. All arranged in a familiar calculator format.

The ADM-31 comes complete with character insert/delete, line insert/delete, erase to end of line/field/screen, back tab, and six send sequences. All standard equipment.

And the Standard Edit option lets the ADM-31 clear to protected spaces, clear to unprotected nulls, and set and reset copy-print.

As if that wasn't enough, the

keyboard includes a caps lock key (to lock the keyboard into upper case only).

THE SMART CHOICE FOR A SMART TERMINAL.

After all this, you're probably thinking the ADM-31 is one of the smartest ideas to come along in quite a while. Modesty aside, we'd have to agree.

So if you're in the market for a new, smart display terminal, consider ours. Then give us a call, or contact your local distributor. We'll be glad to tell you all about our new ADM-31.

A terminal far too smart to be considered Dumb.

ADM 31

Two pages are better than one.



Lear Siegler, Inc./Data Products Division, 714 Brookhurst Street, Anaheim, CA 92803; (800) 854-3805. In California (714) 774-1010. TWX: 910-591-1157 Telex: 65-5444 Dumb Terminal™ terminal is a trademark of Lear Siegler, Inc./Data Products Division.

Conference report: Syntopican VI underscores the inevitable but uneasy combining of two related disciplines.

MERGING OF DP AND WP IMPACTS USERS AND VENDORS ALIKE

Word processing and data processing managers have gotten a glimpse of the enemy and each is trying to figure out if the real villain is the other. Amid their confusion, they know one thing for certain: Their two fields of expertise are merging. That, at any rate, was one notion that surfaced at a recent word processing show.

To illustrate: To Jack Gilmore, Digital Equipment Corp.'s word processing product line manager, word processing and data processing are simply "two logical subsets of information processing." He is not alone, of course, since an increasing variety of products meshing the two functions are making their way into the office automation marketplace, giving proof positive to the much-prophesized pairing of the two fields.

To Gilmore this fledgling field reminds him of "the old days in data processing," and he believes that the growing move toward distributed intelligence will bring more computer-based devices into the office environment.

More and more computer companies have taken the plunge into word processing, prompting one product sales manager to predict that "ultimately all the data processing companies will be into word processing."

There was more than ample evidence of this trend in Washington recently as the International Word Processing Assn. hosted its Annual International Conference and Exhibit, Syntopican VI. Carrying the theme of "Emerging Information Systems," the three-day conference attracted an overflow audience estimated at 8,000.

The Syntopican show drew word processing specialists, plus a smattering of dp and information processing managers. The conference program, which featured panels and over 30 workshops and sessions, attracted approximately 1,850 attendees.

Exhibit goers who had 98 booths to visit totaled over 7,000. The IWP's

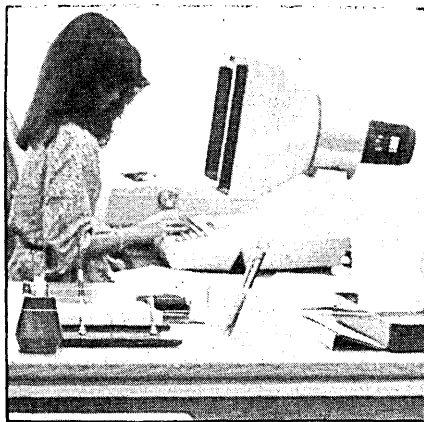

hope for even a better turnout next year when the conference moves to Philadelphia on June 27-29. The two intermediate conference sites are St. Louis, on Oct. 24-26, and Los Angeles, on Feb. 13-15.

The word processing specialists—most of them from government and military circles—showed a keen interest in the dp capabilities of the wp configurations.

One company, Wang Laboratories Inc., has used its multiterminal crib-based systems and a distributed intelligence approach to word processing, as opposed to the traditional standalone or shared-logic system approach taken by other word processing equipment manufacturers. Like DEC, Wang claims to be a firm that early recognized the need to actively compete in both the computer and word processing markets—markets which many industry observers see merging.

"There's going to be a continued merging of data processing and word processing," says Charles Farrell, Wang's product line manager of office systems marketing. "That will happen because of the need to do more than simply improve power typing."

At a press conference during the Syntopican show, Wang Labs executive vp of field operations, John

Cunningham, summed up the company's word processing goals even more succinctly: "We are going in one direction only: to the top of this industry." To get there Wang is pinning its hopes on boosting its wp business volume which it contends has doubled each of the last two years.

Cunningham forecasts that the company will do \$100 million in word processing systems over the next year. By the end of 1980 we expect word processing to represent 40% of Wang's total business, which by then we hope will be running at a rate in excess of \$350 million annually."

DEC manager Gilmore sees the word processing war in the next two years being waged between four major market contenders—Wang, IBM, DEC, and Xerox. Digital says it is getting many customers for its standalone wp set up with an attached communications option.

General Computer Systems, recently acquired by Telex Computer Products Inc., also sees this need and demand for communications power in the word processing area. Says Roy King, Telex senior marketing vp: "Down the road, there's going to be a marriage between intelligent terminals and word processing capabilities."

SHARED LOGIC SYSTEMS

GCS, which has been in wp for the last four years, is focusing on shared-logic systems as the answer to word processing problems. Lloyd Schiller, GCS marketing vp, describes the company's marketing strategy as "piggybacking on Telex's established customers and on GCS' established key-to-disk customers."

Another exhibitor, Cado Systems Corp., of Torrance, Calif. sees the word processing field as a natural "adjunct" to its three main product markets: standalone dp systems for small businesses, distributed processing, and electronic mail.

See things your way

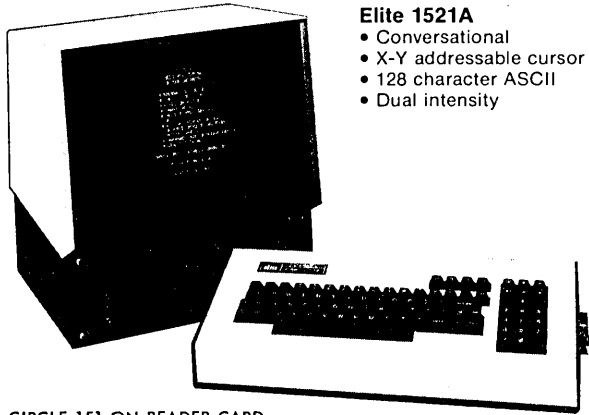

- Elite 1521A**
- Conversational
 - X-Y addressable cursor
 - 128 character ASCII
 - Dual intensity

CIRCLE 151 ON READER CARD

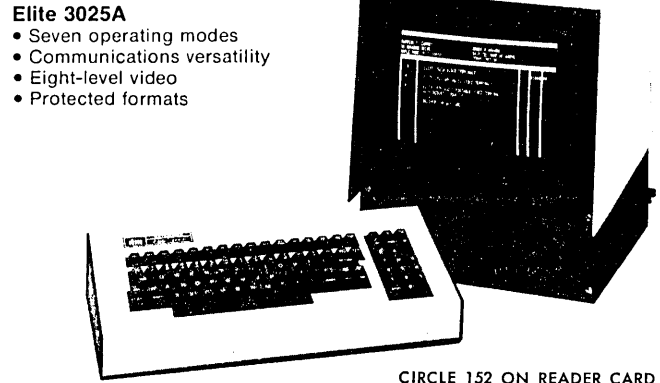

- Elite 3025A**
- Seven operating modes
 - Communications versatility
 - Eight-level video
 - Protected formats

CIRCLE 152 ON READER CARD

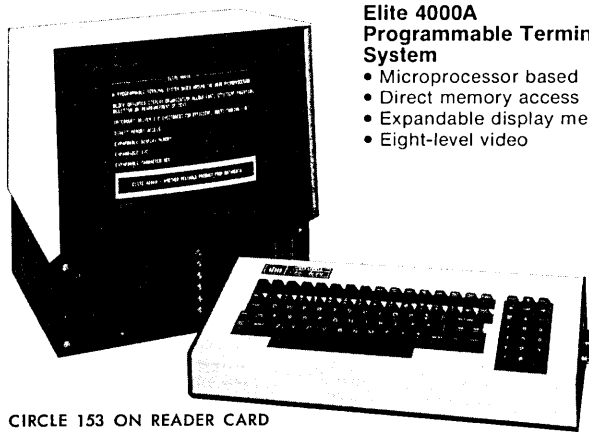

- Elite 4000A
Programmable Terminal System**
- Microprocessor based
 - Direct memory access
 - Expandable display memory
 - Eight-level video

CIRCLE 153 ON READER CARD

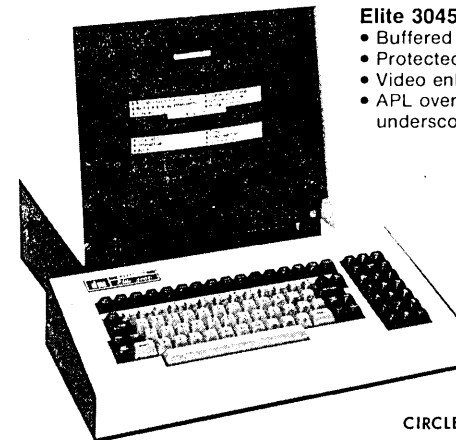

- Elite 3045A**
- Buffered APL/ASCII
 - Protected formats
 - Video enhancements
 - APL overstrike; ASCII underscore

CIRCLE 154 ON READER CARD

with Datamedia Elite Video Terminals

A family of video terminals that offers a wide range of features to perform an even wider range of data entry and display tasks.

If you're an end user, OEM firm, or systems house and look at peripherals with one eye on cost and the other on performance, you'll want to take a long look at these field-proven products from Datamedia.

Their modular design makes troubleshooting a breeze and installation a dream. Their quality workmanship assures that your needs will be met longer than you thought possible.

And if you believe in service after the sale the way Datamedia does, you'll appreciate the new dimension we've given to the word "responsive."

Datamedia. We've been seeing things the right way for users in industry, business services, government, education, medicine and research around the world.

Why don't you see things your way...for a change.

**Datamedia
Corporation**

7300 N. Crescent Boulevard • Pennsauken, NJ 08110 • TEL: 609-665-2382 • TWX: 710-892-1693

Sales and service offices in Chicago, Houston, Los Angeles, and Philadelphia with distributors nationwide

International:

Canada: Datamex, Ltd., Ontario/Quebec • **Belgium:** Inex, (02) 512 4037 • **Finland:** Suma, Oy, (90) 440391 • **Italy:** Eltron s.r.l., (030) 55-26-41554 • **Sweden:** Teleinstruments ab, 08-38 03 70 • **Switzerland:** Teledynamics, 01-56 3300 • **United Kingdom:** Mellor Data, 020629-8181 • **West Germany:** Video Data Systems GmbH, (0 61 81) 7 39 51 • **Australia:** Inteltec Data Systems, (03) 232-3118 • **Japan:** Protech, Inc., (03) 384-0225.



- Elite 3052A**
- DEC® VT-52 compatible
 - Formatting capability
 - Eight-level video
 - Program function keys

CIRCLE 155 ON READER CARD

The Energy Eater Bug.

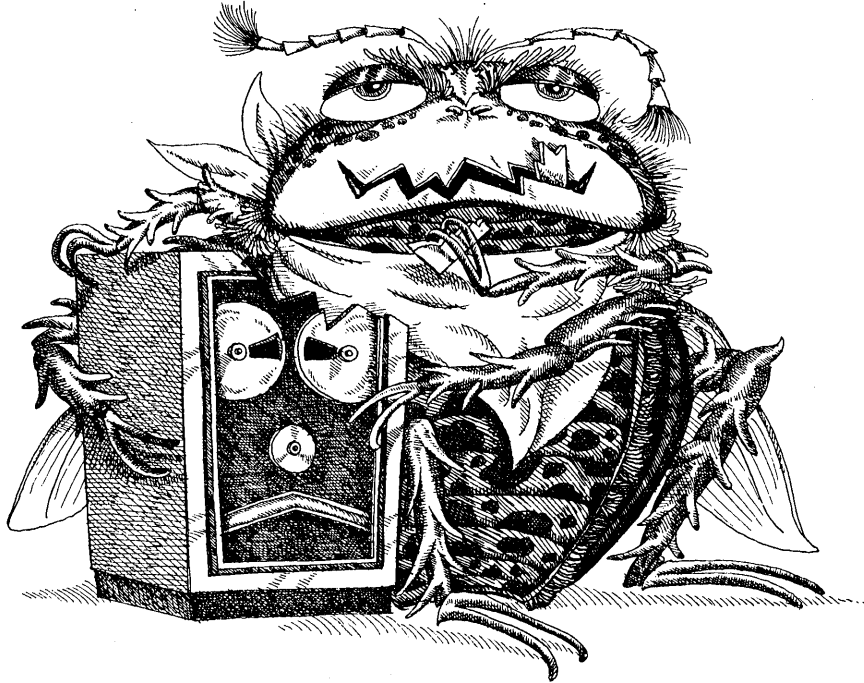

He could be eating up costly energy in your computer room.

The Energy Eater Bug may be costing you a lot of money in unnecessary cooling energy. Now, however, as much as 50% of this energy can be saved with EDPAC's "ECX" Process Cooling System. This can amount to about \$10,000 per year in a typical 5,000 sq. ft. computer room.

With the EDPAC "ECX" option you usually get a proven payback in two years or less.

The "ECX" system achieves this saving by eliminating the costly compressor operation during

periods of cooler weather because it incorporates an additional glycol cooling system.

EDPAC Process Cooling Systems are specifically engineered to achieve an exact, totally regulated environment that protects your computer from all the costly bugs caused by regular air conditioning.

Kick the costly Energy Eater Bug out with an EDPAC "ECX" System — Available either in new or retrofit applications. Contact your local EDPAC Representative, or, send for FREE BOOKLET — HOW TO GET THE BUGS OUT.



Please rush me your money saving booklet.

Please have an EDPAC Representative call and bring me an Energy Eater Bug T-Shirt.



Name _____

Title _____

Company _____

Address _____ Zip _____

Phone _____

Mail to: AC Manufacturing Company, Cherry Hill, NJ 08034

D-98

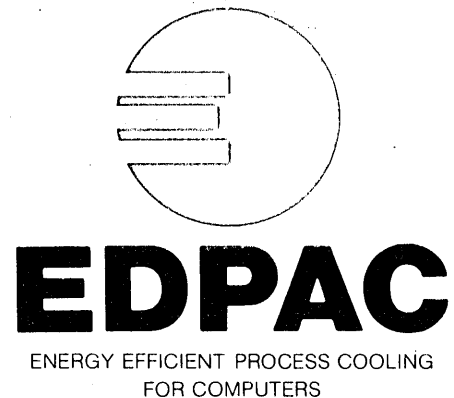

EDPAC is a product of AC Manufacturing Company

If IBM would take the plunge it could be the strongest competitor in the field.

Joel Leslie, Cado Systems' product sales manager for distributed processing, believes strongly in the company's combination approach to word processing.

"By adding these text editing and word processing functions," Leslie explains, "it's a more cost effective solution for the user who doesn't need an extra system to do those functions." Cado's answer then is a "totally integrated system" which Leslie says "performs data processing, distributed processing including remote job entry functions, electronic mail/TWX/Telex message handling as well as word processing all concurrently."

Another first-timer at the show was Augment, Tymshare Inc.'s newly acquired office information systems division. Also promoting an "integrated office information system" approach, the Augment system was developed at Stanford Research Inst. The sophisticated system provides capabilities including text processing, graphics, and photocomposition as well as electronic mail and access to various data bases through the Tymnet network.

Other traditional dp vendors feel the wp'ers recognition of the data pro-

cessing tie-in will be slow in coming. Observes Linda Vyhnal, senior product marketing analyst for Four-Phase Systems Inc.: "Word processing people feel no strong need to be connected to data processing, while some data processing people seem increasingly interested in word processing."

Vyhnal points to the ensuing "struggle" between data processing and word processing. "At some point," she believes, these two factions will have to converge. "More and more of these people are willing to look at each other's point of view. It's a long process but people are slowly coming together."

IBM also has its own definitions of shared-logic systems. While typically refusing to comment for the record, one IBM rep casually conceded that there was a lot of competition in the word processing field, as pointed up by the Syntopian show.

NIBBLING AT THE EDGES

However, industry insiders still believe IBM could prove to be the strongest competitor in the field if the firm would really take the plunge into word processing by coming out with a single- and multiple-station system. So far the mighty company has

been content to nibble away at the edges of this market with such products as the Office System 6 and the WP/32. But industry pundits wonder just how long the company can afford to hold back in the face of the challenge the growing array of word processing companies presents.

Over the next several years, word processing aficionados see more direct clashes between IBM and its hungry competitors in the expanding office automation market. They also see more friction building between the dp and wp managers.

"The data processing manager," says one wp consultant, "sees word processing as a way to build an empire. The office manager will have to have more and more data processing knowledge." Word processing managers and their staffs are delving into higher technology realms such as communicating word processors.

"Word processing managers are familiar," says the consultant, "with all the computer catch phrases and words, and are especially fascinated by electronic mail." Another word processing consultant summed it up by saying: "Data processing has finally captured word processing." *

The DELTA 4050 Display Terminal with proven Burroughs, Honeywell & Univac emulation



Performance proven around the world

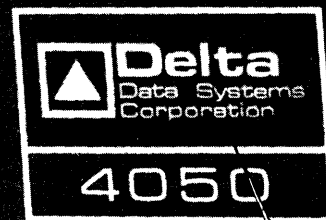

USE THE DELTA 4050 FOR EXISTING AND NEW APPLICATIONS

When you need an emulating terminal, consider the DELTA 4050—the terminal that offers *true* emulation for your existing software. Most so-called "emulating" terminals provide nothing more than communications capability. That limitation will work for some new applications, but what of current jobs? That's where the DELTA 4050 outshines them all: it gets right down to business without modifications. Think of the time you'll save, and the problems you'll avoid.

While you're at it, think about the operating features you'd like to have in your display terminal system. You'll find them in the DELTA 4050 which offers more features and advantages, is more economical and is easier to use than the computer manufacturers' or other companies' emulating terminals. Compare the DELTA 4050 with the others; we think you'll be quite pleased at what you see. Call us now for full details.

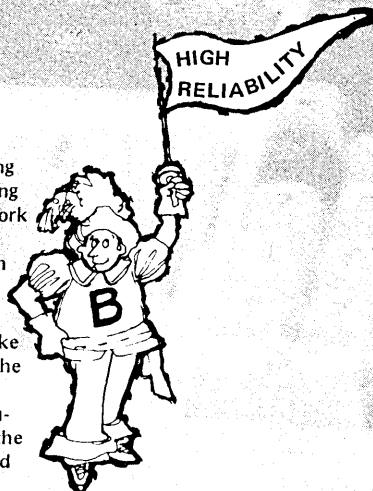

DELTA DATA SYSTEMS Corporation
Woodhaven Industrial Park
Cornwells Heights, PA 19020
Phone: (215) 639-9400
U.K. Subsidiary:
DELTA DATA SYSTEMS LTD.
Welwyn Garden 33833

CIRCLE 174 ON READER CARD

IBM HAS A LOCK ON DOS DFAST IS THE KEY

Five years ago, Tower Systems, Inc. pioneered the concept of a disk management system for DOS users. Today, DFAST is the most extensively used disk management system in the world. And for good reason. DFAST provides more features, offers greater versatility and is supported better than any other similar system. Over 400 DFAST users world-wide can attest to that.

DYNAMIC FILE ALLOCATION DFAST allocates file space from available area on a disk pack. The user is only required to specify the number of tracks for a file, not the starting relative track number.

***AUTOMATIC SECONDARY EXTENT GENERATION** When a disk output extent has been exhausted the system will automatically generate additional extents with no operator involvement or JCL modification.

***ALLOCATION BY LOGICAL RECORDS** Disk allocation may be requested by number of anticipated logical records. The system will calculate the correct allocation based upon the available DASD device types.

AUTOMATIC VOLUME RECOGNITION (AVR) The AVR feature of DFAST allows the system to automatically make logical unit assignments by the serial number in the EXTENT card. DFAST will make these assignments if the logical unit is unassigned or assigned to the wrong pack.

PUBLIC SPACE MANAGEMENT DFAST will allocate area within a user-defined pool of disk drives.

DEVICE INDEPENDENCE Programs may be run on any DASD device type without re-compiling.

***GENERIC DEVICE INDEPENDENCE** DFAST allows the generic device type to be changed at execute time. Disk files may be changed to tape or vice versa without re-compiling the problem program.

***PRIORITY FILE DISTRIBUTION** User may define the search priority for allocation. Avoids stacking all files on same drive. Provides up to three-fold increase in throughput.

FILE CONCATENATION DFAST allocates files as close together as possible, thus eliminating unwanted seek time between files on the same pack.

FILE PROTECTION DFAST allocates area from any available space on the disk, thereby making it unnecessary for operations to delete unexpired files.

***ALLOCATION ON TRACK BOUNDARY** Allocation of files is by track boundary resulting in more efficient DASD utilization.

FILE DELETION DFAST deletes files automatically, or a support

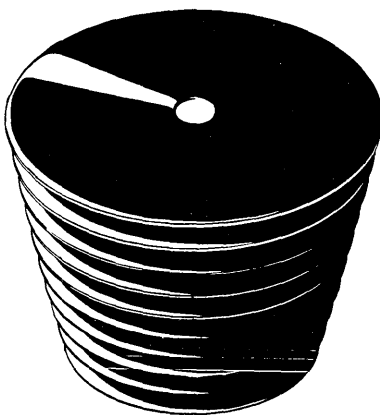

program that will expire files by file name may be included in production job streams to delete files when they are no longer needed by the system.

PARTITION INDEPENDENT DFAST provides a facility for maintaining file uniqueness between partitions. This allows the same file name to be used by more than one partition at the same time on the same disk pack.

TRANSPARENT TO DOS DFAST requires no modifications to the DOS Supervisor, JCL Language, or user Programs. DFAST is DOS and DOS/VS RELEASE INDEPENDENT and is compatible with all other software packages.

HARDWARE SOFTWARE COMPATIBILITY DFAST runs on any model 360 or 370 using the DOS, EDOS, DOS/MVT, or DOS/VS operating system and supports all disk drives (2311, 2314, 3330, 3340, 3344, 3350, 3330 MOD 11).

NO USER CORE NEEDED DFAST functions in the transient or SVA area and requires no changes to user programs or partition allocations.

JCL SIMPLIFIED DFAST does not require explicit fixed addresses for files, thus relieving the necessity of manually mapping the disk.

EASE OF IMPLEMENTATION DFAST is cataloged in the users core image library and starts working immediately. No changes are required to existing programs or operational procedures.

RELEASE UNUSED FILE SPACE (SD FILES) When a sequential disk file is closed, only the amount of area used by the program is protected in the VTOC. The unused area is then available for use by other files. This feature allows the user to make more efficient use of his disk resources.

ENQUE/DEQUE OF DATASETS Files may be protected across partitions at execute time.

***REBLOCK FEATURE** Allows user to modify block size at execution time without re-compiling program.

***PASSWORD PROTECTION** Files may be password-protected to prevent unauthorized access.

Find out how economically you can unlock DOS. DFAST may be purchased or leased at a surprisingly low price. And for tape users, Tower Systems, Inc. offers TFAST — an extremely efficient tape management system.

tower systems, inc.

3901 MacArthur Boulevard, Newport Beach, CA 92660 TWX: 910-595-2780 Phone: 714/752-8263
Dallas Sales Office: The Registry Suite One, 6350 LBJ Freeway, Dallas, TX 75240 214/387-3534

DELTA DATA introduces a new era in video display terminals

A programmable, 16-bit micro-processor terminal for TTY and IBM 3270 communications

A powerful, high performance terminal for OEM's and large system users

A multifunctional terminal for applications in distributed data processing and office environments

Introducing the new DELTA 7000 Series. A family of intelligent terminals which combines the latest 16-bit micro-processor technology with our own proven video display technology. We designed the DELTA 7000 with your interests in mind—from data communications (TTY/IBM 3270 emulation) to specific applications (Text Processing). Then we built in many special features, and loaded the DELTA 7000 with memory to handle your unique applications programs—at a most attractive price.

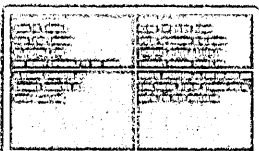
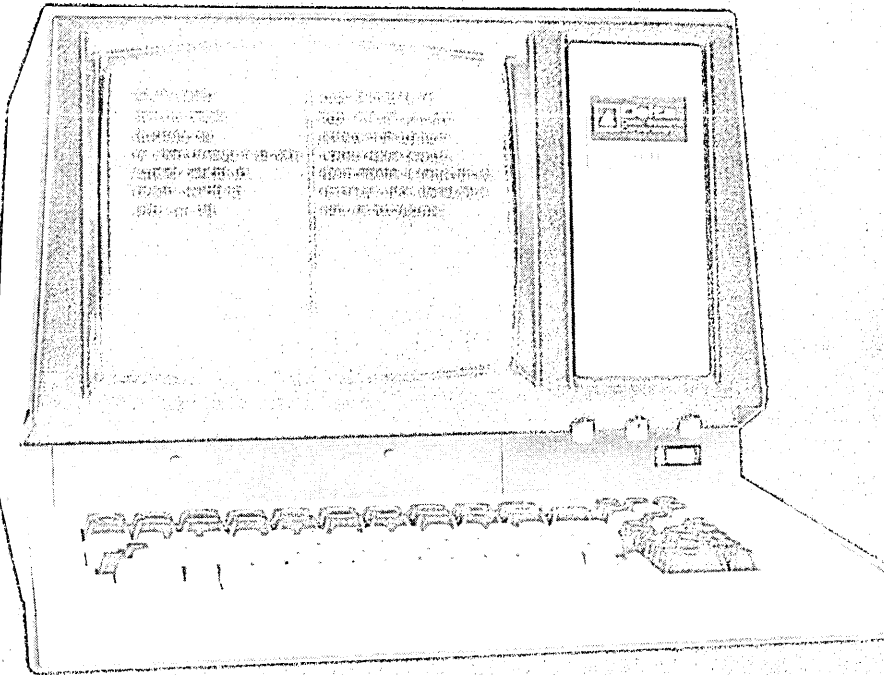

MULTIPLE SPLIT SCREEN
allows you to divide the screen into independent display areas

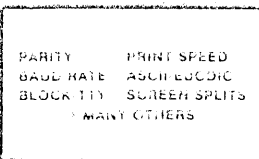

ELECTRONICALLY ALTERABLE ROM
allows status to be set from keyboard or remotely, and retained during power off

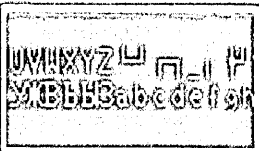

EXTENDED CHARACTER SET
generates special fonts and displays up to 672 different characters

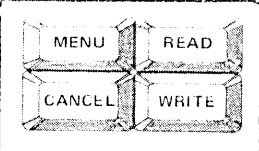

FUNCTION KEYS
permit one key to display or send a string of multiple characters or codes

Enter your new era in video displays with the new DELTA 7000. Write or call for more information today.

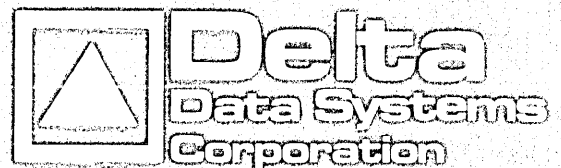

Woodhaven Industrial Park
Cornwells Heights, PA 19020
(215) 639-9400

UK Subsidiary:
DELTA DATA SYSTEMS LTD.
Welwyn Garden 83838

Service in over 150 locations in the U.S. and 14 European countries and Canada.

Programmer/Analyst

International Technical Professional Journal for Application Systems Analysts and Application Programmer/Analysts Timely Commentary of Universal, Professional, Technical, Community, and Personal Significance Technical Notes for State of the Art and Advanced Art Application Environments

Volume 1, Number 1

Third Quarter

July 1978

A
PUBLICATION
FOR
APPLICATION
ANALYSTS
DESIGNERS
AND
PROGRAMMERS

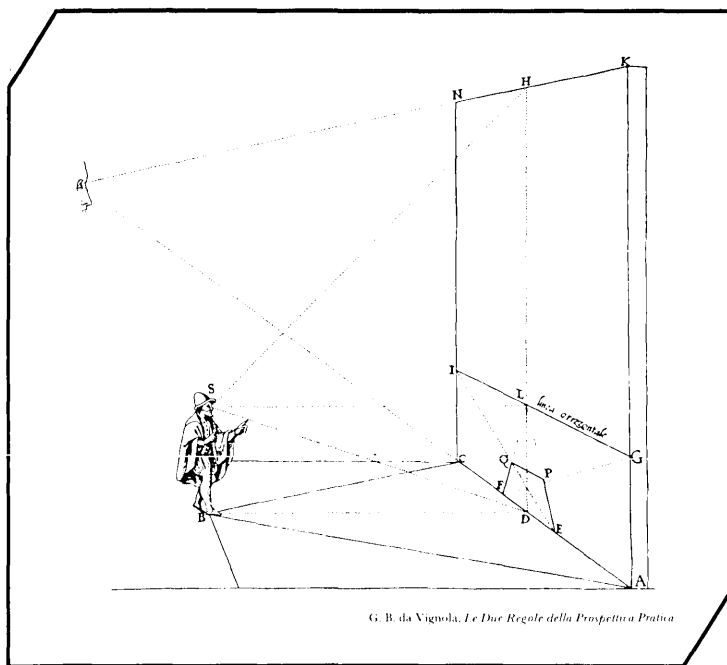

A
PEOPLE
(NOT PRODUCT)
ORIENTATION

YOU ARE INVITED TO SUBSCRIBE TO PERHAPS THE MOST PROVOCATIVE, PERTURBING, SENSITIVE, AND HUMAN PUBLICATION IN THE COMPUTER SCIENCE INDUSTRY.

IN THE FIRST ISSUE

ISAAC ASIMOV

WILL WE BE REPLACED?

1. NO 2. PROBABLY NOT SOON ENOUGH

PROFESSOR PATRICK HORSBRUGH
Director, Envrionic Studies Program
University of Notre Dame

APPLICATION ETHICS

PETER JOHN

Isham, Lincoln, and Beale, Chicago, Illinois
APPLICATION SYSTEMS PERFORMANCE
AND LEGAL CONTEST

PHILIP KRAFT

Associate Professor of Sociology
State University of New York at Binghamton

THE CHANGING ROLE OF WOMEN
IN COMPUTER TECHNOLOGICAL ENVIRONMENTS

MARK A. WILTERDING

Green International, Des Moines, Iowa
COMPUTER GRAPHICS IN BUSINESS ENVIRONMENTS

APPLICATION ANALYSTS, DESIGNERS,
AND PROGRAMMERS:
THE PROFESSIONAL OMNITECTS

THE STRIDE TOWARD EXCELLENCE

PROFESSIONAL INTEGRITY AND
PROFESSIONAL ETHICS

THE SOLIDIFICATION OF A PROFESSION

WOMEN AND THE PROFESSION

A BRIEF HISTORY OF COMPUTER SCIENCE
AND APPLICATION PROGRAMMING

PROFESSIONAL DILEMMA: SUICIDE AND DIVORCE
ALTERNATIVES: PERSONAL AND FAMILY COUNSELING

WHERE HAVE ALL THE FLOWERS GONE . . .

A CORPORATE MANAGEMENT INFORMATION
CENTER PROFILE

EFFECTIVE DESIGN OF COMPUTER GENERATED
PRINTED OUTPUT

SYNOPSIS OF EXISTING TECHNICAL AND
PROFESSIONAL COMPUTER INDUSTRY SOCIETIES

SYNOPSIS OF CONTINUING EDUCATION PROGRAMS

TECHNICAL AND COMMUNITY INFORMATION
OF PARTICULAR INTEREST

Book Reviews • Movie Reviews • Conference Reviews
Fiction • Anon

PROGRAMMER/ANALYST
Published By



Frank E. Alexander
CEREBRATONIA-RENAISSANCE PRESS
Chicago (312) 438-9400 • Toronto (416) 621-6942

PUBLISHED QUARTERLY

CIRCLE 25 ON READER CARD

**YOU ARE INVITED TO PARTICIPATE IN
SOUTH EAST ASIAs' PREMIER EXPOSITION
DEVOTED EXCLUSIVELY TO**

**THE INTERNATIONAL COMPUTER EXPO
TOKYO, JAPAN**

February 28, March 1 and 2, 1979

**THE FIRST
MAJOR INTERNATIONAL COMPUTER EXPO
TO REACH ALL OF
SOUTHEAST ASIA**

The **International Computer Expo** — is not just another trade show in a new location . . . it is an exposition created for you the manufacturer to communicate, face to face, with a prime audience of South East Asia's computer market . . . the original equipment manufacturers and end users from Japan . . . Korea . . . Singapore . . . Taiwan . . . Malaysia . . . Hong Kong . . . the Philippines . . . China . . . and the Soviet Union.

An event of this importance must of course establish its credentials. Our credentials begin with our sponsors . . .

Dempa Publications — Co-sponsor. Asia's largest and most renowned publishing company . . . publishers of *Dempa Computer* . . . *Journal of the Electronics Industry* . . . *Journal of Electronic Engineering* . . . *Asia Electronics United* . . . and the *Electronics Buyers Guide*.

Jetro — Japan External Trade Organization. Co-sponsor.

International Computer Expo — is supported by the United States Embassy, Tokyo.

International Computer Expo — has been endorsed by the United States Department of Commerce and the International Computer and Infor-

mation Processing Association of Japan.

Exhibits will feature: Microprocessors — Small Business Systems — Programmable Calculators — Minicomputers — Medium Size Computers — Peripheral Controllers — CRT Display Terminals — Remote Batch Terminals — Intelligent Terminals — Point of Transaction Terminals — Tape Transports — Rotating Memories — Extended Core Memories — Printers — Plotters —

Teleprinters — Card and Reader Punch equipment — Concentrators — Modems — Multiplexers — Test and Monitor Equipment — Communications Processors — SOFTWARE PACKAGES for Systems, Scientific, Commercial, Teleprocessing, Minicomputer, and Word Processing Applications — Computer Output Microfilm — Optical Readers and

Scanners — Key to Tape Disc — Graphic Display and Design — Minicomputer Peripherals — Stand Alone Word Processors — Shared Logic Systems — Time Shared Services — Magnetic Tape and Disk Packs . . .

You can not afford to miss this opportunity to display your product to the rapidly growing markets of South East Asia.



CO-SPONSORED BY

**DATA/MATION
MAGAZINE**

THE INTERNATIONAL COMPUTER EXPO is produced and managed by Golden Gate Enterprises, Inc.
1307 South Mary Avenue, Suite 210, Sunnyvale, Ca 94087 Telephone (408) 735-1122

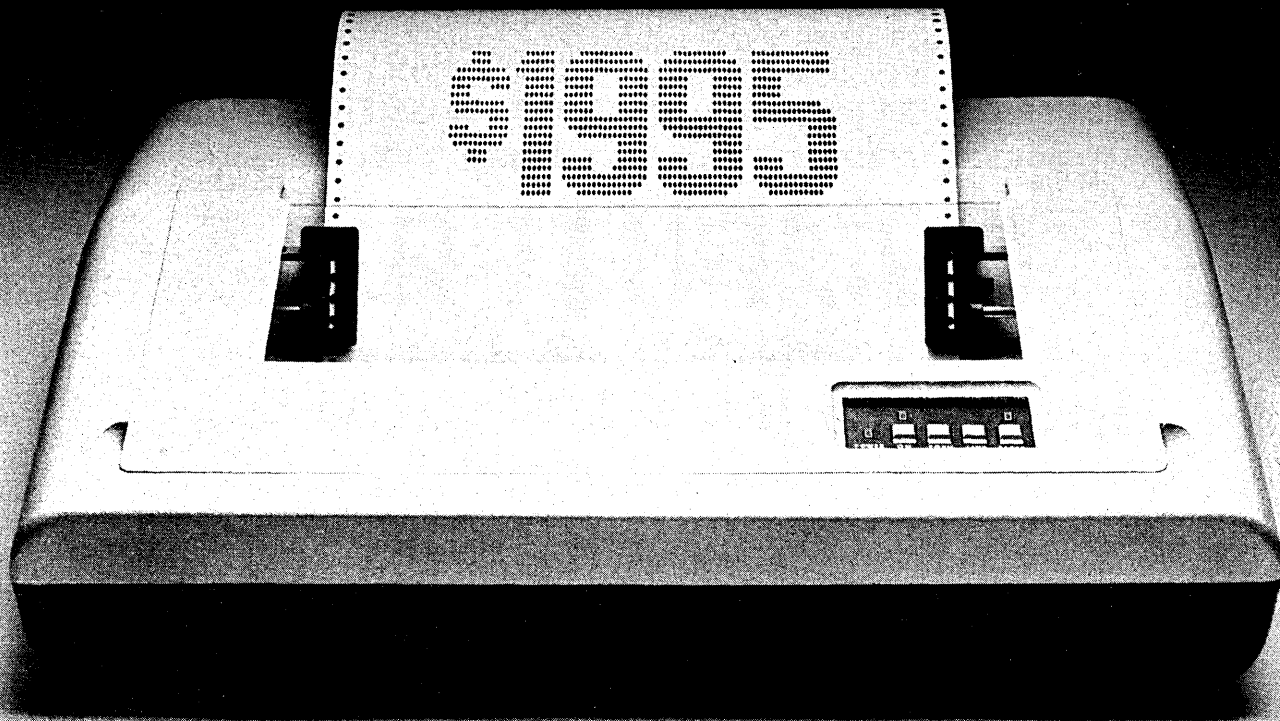

Bells and whistles standard.

When you buy our 300 Series Ballistic™ Printer, there's one thing we won't offer you much of.

Options.

Because we made most of them standard on the 300. And lowered its price, too.

NOT MANY OPTIONS. BUT A LOT OF STANDARDS.

The new 300 Series Ballistic Printer is a low-cost, 180 cps matrix printer with a built-in microprocessor. It gives you 15 switch selectable form lengths, 15 perforation skips over formats, and full horizontal and vertical tabulation control. Space and blank character compression. Interface control for serial, parallel, or polling and addressing operation. X-ON, X-OFF, capability. Plus a non-volatile forms retention system that retains these programmable settings when power to the printer is turned off.

The 300's character buffer is optionally expandable to 2048

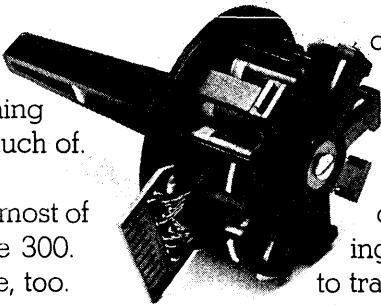

characters. With it, the printer can fully buffer a 1920 character CRT screen of data without waiting for the screen to transfer to the printer on a line-by-line basis.

THE 300 HAS A GOOD HEAD ON ITS SHOULDERS.

Like all our Ballistic Printers, the 300's dependability originates with its ingeniously simple, patented Ballistic Print head. Instead of moving cores attached to the wires, it uses small armatures that propel its matrix wires in free flight to the platen.

This revolutionary principle greatly reduces drag. Minimizes wire tip wear. Eliminates clogging with inks, dust, and paper fibers. And most importantly, significantly increases head life.

When the head finally does wear out, you can replace it

yourself. In minutes. Without a single service call.

IT HAS PRACTICALLY EVERYTHING. EXCEPT A BIG PRICE TAG.

The 300 Series has a full 96 ASCII character set, with up to 128 printables optionally expandable to *two* sets of 128. Which makes it great for bilingual applications. It's even got an elongated character capability, and 10 or 12 pitch standard, with a 10/16.5 dual pitch option. Not to mention 100% duty cycle operation.

On top of that, you get the whole package for a measly \$1995.

Honest.

After all, we couldn't print it if it wasn't true.

300 SERIES Ballistic Printer

Tougher in the long run.



LEAR SIEGLER, INC.
DATA PRODUCTS DIVISION

Lear Siegler, Inc./Data Products Division, 714 Brookhurst Street, Anaheim, CA 92803; (800) 854-3805. In California (714) 774 1010. TWX. 910-591-1157 Telex. 65-5444

NOVA*

\$SAVER



*Product trade name of
Data General Corporation

†Single Unit price

OUR NEW \$1750[†] DISC CONTROLLER

THE DC-220A DISC CONTROLLER

- Emulates DG 4234 or 4046.
- Interfaces virtually any cartridge drive (5440 or 2315).
- RDOS and IRIS compatible —no modifications.
- All the features of the DC-220, and then some.
- Fast delivery.

PLUS

Advanced engineering and manufacturing coupled with volume production have enabled us to bring you the newest version of the popular DC-220 at this unbelievable price.

SEND FOR COMPLETE INFORMATION

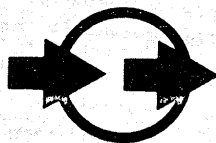

western peripherals

Division of WESPERCORP

1100 Claudina Place, Anaheim, CA 92805 ■ (714) 991-8700 ■ TWX 910 591-1687 ■ Cable: WESPER



NICHOLS

OFFICE BUILDING

KAZ CORPORATION

The difference between high and low reliability with standard systems is due to management dedication (and considerable yelling at customer engineers).

WHAT MAKES A SYSTEM RELIABLE?

by George A. Champine

Users commonly feel that they have no influence over the design of new computer systems and feel very frustrated in that they can not get corrected what they consider to be design errors in present systems. And yet, there are many cases of a single user having considerable influence over the design of new computers, if he has a valid case and states it graphically to the right audience at the right time. An example of this is a talk given by Dr. Robert Worsing, then director of the computing department for Boeing and now vice president, development and operations for Infonet at Computer Science Corp. The talk was to a group of customer engineers in 1967 on the topic of system reliability. He said in part, "How many of you would board a (Boeing) 707 which, despite two hours of preventive maintenance *every* day, had a probability amounting to certainty that it would require airborne maintenance at least once between midnight on succeeding Sundays?

"Why do you expect so much more reliability with an airplane than with a computer? They aren't any more expensive. They are not kept in a special environment. It is just as intolerable to allow the collection of gadgets we call a computer to admit of unreliability as it is to allow the collection of devices we call an airplane to admit of unreliability. So to repeat myself, I expect from you simply perfection."

The complete text of this talk has been required reading in at least one system design organization, and this talk is known to have substantially influenced the design of several computers in the reliability area.

FAIL-SOFT SYSTEMS Users say that their most vital need is for computer systems that continue in operation even though one component has failed—what are called fail-soft systems. The priority of this need grows out of the transition from purely batch processing in the 1960s and early 1970s to increasingly interactive operation—including transaction, time-sharing, and real-time—which is widespread now and will be even more so in the 1980s. System failure in batch operation has relatively little impact on users if it can be corrected in one or two hours. However, system failure in an interactive environment has a devastating impact on users. Because of increasing dependence of users on their dp systems, the importance of fail-soft systems is becoming paramount—it is becoming increasingly true that if the dp system stops, the organization also stops.

Technology to achieve fail-soft systems has been available for some time, and has found widespread application within military systems. Now, this same technology is being adopted by the commercial world. The techniques include redundancy, which means that there are two or more of every system element, so that if one fails the system can still operate. Another technique is automatic reconfiguration of remaining system elements in case of a failure of any one element. For those failures which are transient in nature, it is important to have automatic system recovery so that the system can resume full operation without destroying the integrity of the data. At the level of the hardware, hardware error correction codes are becoming standard in main storage. Instruction retry is also becoming standard in processors.

Perhaps no other single characteristic of computer systems has caused

more grief to dp operations managers than that of a system failure. Everyone acknowledges that physical systems do fail, and yet devastation of operations results too often from system failure. At best, a system failure stretches out response time to users; at worst, it can corrupt data vital to company operation, bringing the entire organization to a halt. Even as important as system reliability is to operations, it remains a little understood topic, seemingly viewed by many as tedious or of little practical value. Because of the subject's current importance, every dp manager should be aware of the basics of system reliability. Further, it is going to become even more critical for future dp systems than it is for present systems.

Computer salesmen do not like to talk about system failure rates or down time because it is a negative topic that does not contribute to the solution of the customer's problem. In contrast, engineers love to talk about failure rates because failures are problems, and engineers make their living by solving problems. Perhaps for this reason, the early computer users planned on 5 hours mean time between failures (MTBF) based on conversations with engineers, got 10 hours MTBF, and were very successful in their applications. Later computer users sometimes planned on 500 hours MTBF, got 50 hours, and ended up with colossal disasters which could not support the needs of the organization. The results at the operational level are much different between planning on 500 hours MTBF and getting 50, than planning on 50 hours and getting 50 hours.

A true case study in which the author was involved might give some insight as to how things can go wrong from a reliability standpoint.

A system had been purchased and installed for a critical application involving interactive query and update of a logistics information system, and

high availability was of the utmost importance. The system, which was designed and configured to fit the users' budget, had a single processor and 10 mass storage devices, all of which had to be operational for the system to work. The media on the mass storage was nonremovable. Dumping a single mass storage device to tape to allow maintenance without endangering the data base, and then reloading, took 4 hours. The system had to be operational 20 hours per day to meet the user's needs. Normal system preventive maintenance took 2 hours per day.

The design MTBF for the mass storage devices was 500 hours; however, the achieved MTBF was only 250 hours.

$$\text{Availability} = (0.98)^{10} \approx 0.80$$

The other system components, including software, brought the total system availability down to about 0.76.

If the above problems were not enough, the designers of the system did not believe in error detection circuits, and the system often ran several hours in a fault condition generating garbage in its master file, with no one the wiser. About this time the user was climbing the walls and writing nasty (but very well documented and supported) letters to the president of the computer supplier. Clearly heroic measures were called for.

The attack on the problem was multipronged, because every subsystem had to be raised to the highest possible availability. However, the focus of the attention clearly had to be the mass storage subsystem. Factory personnel were brought in who refurbished the mass storage devices on a rotational basis, having furnished a spare for system use. The operating margins were widened to the maximum possible extent by the use of selected and matched components, and very careful tuning. As a result, the MTBF of the mass storage devices was raised from 250 hours to 1,250 hours, or 2.5 times the design goal. System availability rose slowly to about 0.96, the customer was overjoyed, and the systems are still in use as of this writing.

The development of reliable systems is becoming more difficult from a computer design point of view. At the same time that users are properly demanding more reliable systems to meet the needs of interactive operation, they are also demanding much larger and more complex systems to cope with the increased functional and communications requirements of the applications. It can easily be shown that the

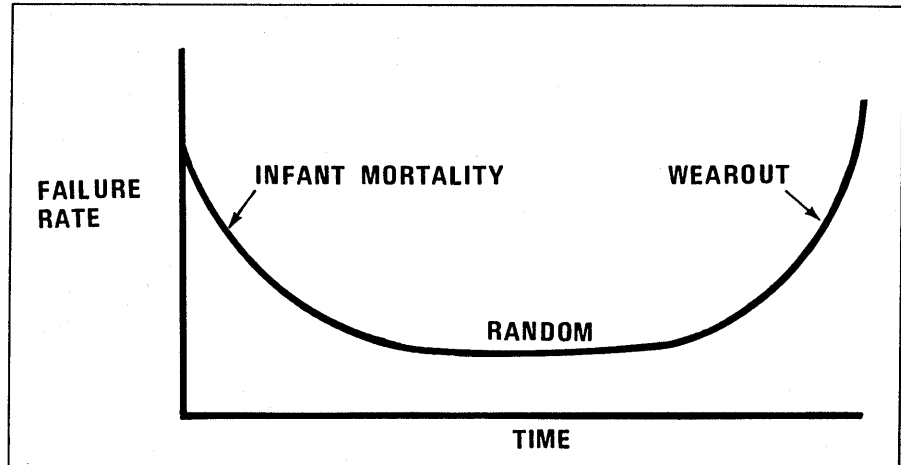

Fig. 1. The failure rate of components follows the "bathtub curve." They experience a high failure rate in infancy due to manufacturing defects, and then a relatively low failure rate during their normal lifetime.

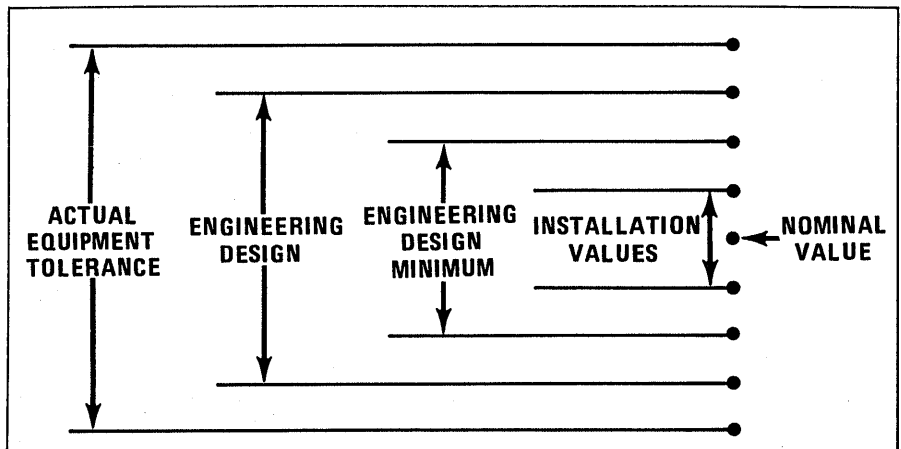

Fig. 2. Engineering designs usually allow for a greater tolerance than that expected to be necessary in an installation, and the equipment is usually somewhat more tolerant than the design calls for. Thus, the environment theoretically should never give trouble; but the real world doesn't always go by the theory.

larger a nonredundant system becomes, the less reliable it becomes, and a sufficiently large system will never run long enough to give useful service. Fortunately, by the use of redundancy, system reliability can be significantly improved in spite of increased complexity.

Both the computer system manufacturer and the computer system user must contribute to system reliability. The manufacturer can supply tools to

Dr. Champine's feature has been adapted from his book, *Computer Technology Impact on Management*, which is being published this month by North Holland Publishing Co., Amsterdam (292 pp., approx. \$27 U.S.) Permission to reprint it here is gratefully acknowledged.

improve system reliability, such as multiprocessing/reconfiguration, error correction in storage, instruction retry, maintenance processor, mass storage retry, and software recovery from hardware failure.

The user, however, also must provide for adequate system availability at the application level through appropriate methods of system implementation, such as audit trail, before/after looks, roll-back, file recovery, and data base recovery.

A very wide variation in system reliability is observed in the field. A "typical" large scale computer system will crash (require an unplanned restart) somewhere between once per day and once per week, and may be unavailable 2% to 5% of the scheduled oper-

The principal environmental factor affecting reliability is the power supply.

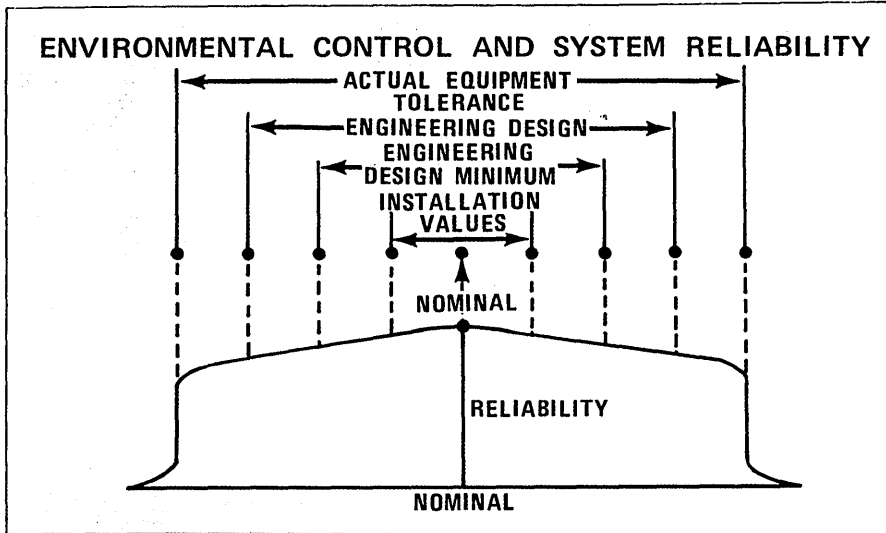

Fig. 3 When the actual operating point approaches the actual equipment tolerance limit, reliability falls off catastrophically.

ating time. And yet, a large and well known time sharing service company using standard product hardware has a long term down time average of about 0.5%. The difference is due almost entirely to user management dedication to achieving high availability (and considerable yelling at the customer engineers when reliability goals are not met).

For a system to be reliable, the reliability must be designed in at the most primitive electrical, magnetic, and software level, and it must be carefully preserved at all levels of design. For this reason, the following discussion of reliability begins at the basic level with components, and then progresses upward through the more complex areas of hardware systems, effect of environment on reliability, software recovery from system errors, and software systems. Concepts will be illustrated by example rather than by complex mathematics.

COMPONENT RELIABILITY

All hardware systems begin with components, including transistors, resistors, wires, integrated circuits, diodes, and connectors; consequently, failures are at this component level. Each of these components ultimately will fail to perform its desired function, because of time-dependent parameter changes. These changes can be sudden (microseconds) or at an almost undetectably slow drift (years). In the case of slow drift, the point at which failure occurs depends to a large extent on the design: if the design is tolerant of parameter

changes the time to failure will be much later than otherwise.

If the discussion is confined to catastrophic failures, experience has shown that a collection of large numbers of one kind of component will exhibit a failure rate shown in Fig. 1. This failure rate profile, known as the "bathtub curve" for obvious reasons, exhibits a high failure rate early in the component life as the components with manufacturing defects fail, and then a relatively low failure rate during the normal life of the component. The failure rate then rises as end of life is reached and wear-out or parameter-drift mechanisms predominate.

It is an economic fact of life that it is much cheaper for the manufacturer (and also for a user) to fix system failures in a factory before it is shipped, rather than at a customer location. For this reason, components normally undergo "burn in" before shipment, to get beyond the high failure rate early in the component life. Another technique used to eliminate marginal components in the factory is temperature cycling during operation.

Each type of component is normally assigned a failure rate value to be used in estimating system failure rates. For example, a typical integrated circuit used in a processor might have a failure rate of 10^{-7} failures per hour. This means that a collection of 10,000 circuits of this type for a typical large scale processor would have an aggregate failure rate of 10^{-3} failures per hour, or a mean time between failure of 1,000 hours, which again is typical for a large scale processor.

THE ENVIRONMENT

The electrical and thermal environment of computer system installations can play a major role in hardware reliability. A low cost installation which uses marginal power distribution, marginal chilled air flow, and which mixes power and signal cables haphazardly under a false floor can seriously degrade or even totally disable a computer system. Conversely, even a well-designed and adequately funded installation can also have problems as the following case history illustrates:

A large scale computer system was purchased and installed in a large Japanese industrial corporation. Although this product had performed well in other locations, the reliability in this installation was terrible, averaging only about six hours MTBF. The installation was well planned and executed, and subsequent reviews failed to identify any weak areas. Measurements of the computer equipment also showed adequate operating margins in all areas. Finally, experts from the manufacturer's engineering organization were called in to try to solve the problem. By this time there was the usual finger-pointing going on with each responsible organization saying the problem was somewhere else.

The manufacturer's engineer began running a series of exhaustive tests in the evening, and immediately noticed an interesting phenomenon. As long as he watched the system, it ran perfectly, but if he left the room to get coffee or something to read, the system would have failed by the time he returned. This phenomenon was reasonably repeatable, so the engineer began to see how far he could go from the computer before the system would fail. He began by sneaking out of the computer room to go for coffee but no matter how quietly he left, the system would stop before he got back. Next, he tried making a big show of leaving the computer room, making sure the system could both hear and see him leave. Then he would hide just outside the computer room a few seconds, and then spring back into the room trying to catch the system in the act of failing by this tactic. Finally, the engineer began strolling farther and farther down the hall, then racing back to see if the system had failed, but it never had unless he went downstairs to his office or the coffee machine.

Finally, it was discovered that the ground of the motor on the elevator was tied to the electrical ground

of the computer, but this connection was not shown on the building engineering prints. Every time the engineer took the elevator to the coffee room or his office, the electrical transient induced by the elevator motor caused a fault in the system.

As suggested by this story, the principal environmental factor affecting computer reliability is the main electrical supply. The power companies disclaim any responsibility to provide well-regulated, noise-free power. The quality of power supplied to all users has degraded slowly over the last decade, not just with the well known brownouts, but also in the level of noise in the power system. Computer systems are often specified to tolerate a 10% voltage deviation in the supply. Yet a recent survey taken by an industry group found that a typical computer power source had 56 incidents per month where electrical noise transients exceeded this limit. Noise transients of 50%, caused by the switching of large inductive loads, were not uncommon. Fortunately, computer systems are designed to accommodate power variations substantially in excess of this specification. However, computer installations requiring high reliability often use motor alternators and uninterruptible power supplies to reduce system outages due to power problems.

All electrical equipment is designed for a nominal operation point, for example 208 volts, with a given tolerance for installation variance around the nominal point, such as plus or minus 10%. To assure that the tolerance published for installation values can in fact be accommodated, engineering design minimums are established which provide wider tolerance than the installation values. The actual engineering design is somewhat more tolerant than the minimums, and the actual hardware is somewhat more tolerant than the design. This cascading of tolerances is shown schematically in Fig. 2.

With all of these equipment tolerances, it would seem on a theoretical basis that environmental conditions should never give trouble. But in actual practice many problems arise which compromise the tolerance of the system, including out-of-tolerance components, manufacturing flaws, and design errors. But the major causes are environmental parameters being out of tolerance and incorrect installation. The reason for this is that each system is tested in the factory to the design minimum tolerances, which are broader than the installation values; this eliminates most, although not necessarily all, mar-

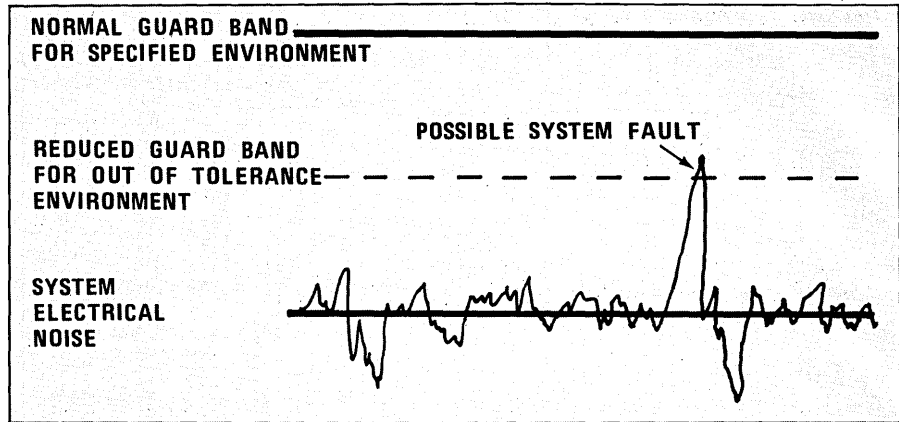

Fig. 4. When the actual operating point deviates from the point at which the equipment was designed to operate, there's less of a buffer against ever-present "noise" and failure becomes more likely.

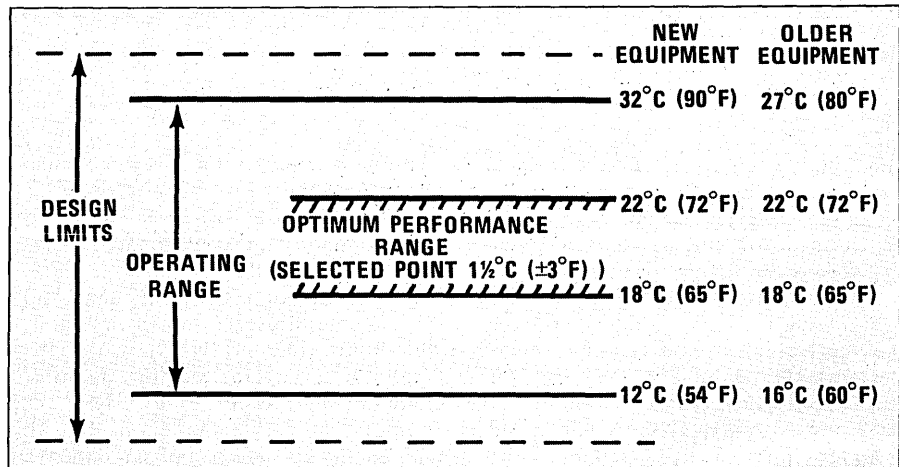

Fig. 5. Just as for electrical power, specifications for operating temperature allow for some latitude. System reliability is lower outside the normal range though, again just as it is for power variance.

ginal components, manufacturing flaws, and design errors.

Even though installation variation data is published, and systems will indeed run at the extremes of the tolerances and more, for example 228 volts instead of 208, the best reliability is obtained at the nominal point. As the actual operating point deviates more and more from the nominal, reliability slowly but steadily degrades even within the allowable installation tolerance as shown in Fig. 3. When the actual operating point exceeds the engineering design point and approaches the actual equipment tolerance, reliability falls catastrophically.

The reason for this is diagrammed in Fig. 4. When the operating point is at the nominal value, the normal guard band exists against system noise. As the operating point deviates from nominal, the guard band is steadily reduced and the system becomes

increasingly susceptible to noise, and therefore less reliable.

The problem of power line variation can be improved greatly by various techniques. A motor-alternator can be used to smooth out high frequency noise. A tapped transformer can be used to compensate for brownout conditions. The problem of power outages can be alleviated greatly, often at moderate cost, by obtaining a supply from two different power generating plants, supplied over two different sets of lines. Finally, for the highest reliability level, uninterruptible power sources are available that will supply power for durations of minutes from batteries and indefinitely from backup diesel generators.

Although the above discussion has considered electrical parameters, the same principles hold for thermal parameters. Fig. 5 shows a typical specification for temperature which calls for an

A sufficiently large system will never run long enough to do useful work.

operating point anywhere in the 18°C to 22°C (65°F to 72°F) range. The best results are obtained by selecting a temperature within this range and restricting temperature excursions to ±1.5°C (±3°F). The equipment will operate, with reduced reliability, within the range 12°C to 32°C (54°F to 90°F) and beyond.

When a nominal operating point is not published, it is important to keep the system at a constant operational value, for example in temperature. The reason for this is that normal maintenance activity tends to "tune" a system to its existing environment, and this then becomes its nominal operating point for best reliability.

SYSTEM RELIABILITY

At this point it is necessary to introduce two more terms and two relations. The terms are: Mean time to repair (MTTR) and Availability (A). Mean time to repair is, for any system component, exactly what the name implies, with the proviso that it must include rerun and data base recovery time. Availability is defined by the relation:

$$A = \frac{MTBF}{MTBF + MTTR}$$

and is the fraction of the time the component is operational. These definitions are too crude to satisfy the expert, but are adequate for our purposes here.

Availability can also be defined at the system level using the same relation, where MTBF becomes the time to any failure which by definition stops the system from completing its objective. The availability A of the system, can be computed as the product of the availabilities of each of the components A_i necessary for operation as follows:

$$A_{(system)} = \pi(A_i)$$

where A_i are the availabilities of the individual system components.

In order to have a reliable system, each component in the system, including processor, input/output, disks, printers, and terminals must individually be reliable. As an example of this, assume that the system is composed of 20 components, each of which is 99% available. If the system works only if all components work, then the availability of the system is:

$$(0.99)^{20} \approx 0.80$$

A system with 80% availability is not acceptable for most data processing applications. As the number of components increases, the availability becomes even worse, so a sufficiently large system will never run long enough to

produce useful work.

A medium to large computer system has more than 20 components, but fortunately the availability of each component is almost always higher than 0.99. The values in Table 1 are typical of MTBF values for components of a large scale system.

A typical mean time to repair is one hour if maintenance personnel and spares are on site. Otherwise travel time of up to four hours should be added. However, in the case of tape units and disk units with removable media, the "time to repair" is the time to move the media to a new drive. This can be less than one minute if the operator is alert.

SYSTEM INTEGRITY

Now that the likelihood of a system failure has been both admitted and quantified, it is appropriate to preach a short sermon on system integrity. This is not to question the system's morals, but to raise the issue of the fidelity of the data coming from the system relative to inputs and programs. It is forgivable for a system to fail and cause an error in data; but it is not forgivable for a system to fail and cause an error in data without any indication. Fortunately, most failures become apparent rather quickly because the system stops or does something irrational. But it is not unknown for a failure to occur in which the machine continues to run and generate erroneous data with no indication. In one personal experience, a failure in an on-line inventory control system caused erroneous information to be written into an important data base for more than five hours before the malfunction was discovered. The data base recovery from the audit trail and subsequent rerun time took 24 hours in addition to the five unproductive hours generating bad data.

The point is that data whose integrity is questionable is worthless. Therefore an absolutely essential characteristic of a system is comprehensive error detection. Comprehensive error detection is the foundation of all high availability systems because it triggers the recovery mechanism; without comprehensive error detection a system is worthless. End of sermon.

Systems of today have adequate error detection in main storage and mass storage through the use of error correction codes. Error detection is also adequate in the I/O and data path areas through the use of parity. But there are many systems where the processors do not have adequate error detection because it has been expensive. Fortunately, because of the reduction in cost

TYPICAL MTBF FOR LARGE SCALE SYSTEMS

Components	MTBF (hours)
Central processor with I/O	1,000
Main storage (10 million bytes)	4,000
Disk unit	2,500
Controller	3,000
High speed printer	300
Crt terminal	3,000
Tape drive	1,000

Table 1. These are typical values for the Mean Time Between Failures figures of today's equipment. Since the numbers are large, the availability of each component is almost always over 99%.

of logic, it is becoming economically attractive to duplicate the processor and execute each instruction twice in parallel; if the answers match it may be safely assumed there has been no error. Systems using this approach can approach 100% error detection capability.

SYSTEM MAINTAINABILITY

The current approach to system maintenance for a large scale system, is to run it until it fails, then use on-site maintenance personnel to repair it while it is down, and then continue. The environment is changing in two areas which will make this approach less and less viable in the future.

As mentioned at the outset, a large scale computer system typically fails at a rate between once per day and once per week. The causes for the "crashes" are generally divided equally among: (1) hardware, (2) software, and (3) "other" and "unknown."

The "other" category includes operator error and environmental problems. The time to recover from the failure can range from 10 minutes for a warm-start reboot, to one hour for on-site maintenance repair of a hardware problem, to five or more hours for hardware repair by off-site maintenance personnel or for particularly difficult problems. Unfortunately, it is not altogether unknown for a system to be down for days with a particularly vexing problem.

There is an increasing number of applications, primarily interactive, where system failures once per day or even once per week are not acceptable.

XEROX
INTRODUCES
A NEW WAY
TO PRINT OUT
PRINTOUTS.

Believe it or not, this is a computer printout. And, believe it or not, it took less than a second to make.

That's because Xerox created a totally new way of printing. The Xerox 9700 Electronic Printing System.

It lets you printing lets you design and change reports, letters, forms, and mailings and ready.

It lets you design and print reports, letters, forms, and mailings that are different than any other printouts.

The 9700 is a unique computer system that stores a number of different kinds of formats with the advanced technology of lasers and semiconductors. So you can electronically design and print reports, letters, forms, and mailings in less than a second.

*You can make the typestyle
and size you want.*

There's no need to design, print and store preprinted forms. Which means you never have to go through the trouble of changing them if you ever need them again. You can design and print them on the spot.

And the 9700 delivers up to 14 pages a minute as fast as you need on executive size 8-1/2 x 11 paper at 2 pages per second.

For more information, write Xerox, Electronic Printing Systems, Dept. AI-10, 701 S. Aviation Blvd., El Segundo, CA 90245.

You'll find the 9700 is the newest way for you and your printouts to both come out looking better.

XEROX

XEROX CORPORATION, 701 S. AVIATION BLVD., EL SEGUENDO, CA 90245

PRINTED IN THE U.S.A.

There are almost no applications where a system outage of several days is tolerable.

The cost of on-site maintenance personnel has risen to the point where on-site maintenance is no longer economically sound except on the very largest systems. To put it on a quantitative basis, the cost per man hour of on-site maintenance increased 400% from 1965 to 1977. Except for on-line preventive maintenance of electro-mechanical equipment, the maintenance personnel mostly wait for system failures. Meanwhile, they forget their training in the repair of the electronic equipment, and when a failure occurs, the proper diagnostic procedure must be relearned.

Several measures are being taken to solve these problems simultaneously, primarily based on using increased amounts of hardware. To improve system reliability, the additional hardware is used to provide redundant systems, such that there are two or more of every component in the system. If one component fails, the rest continue in operation, so the system continues in operation, although with possibly degraded performance. More about this later.

In the case of controlling maintenance cost, the principal approach is to substitute increasingly lower cost hardware for increasingly high cost maintenance personnel. The substitution takes several forms. Additional, redundant hardware is configured into the system so that, in the event of failure, the system can continue to operate until the maintenance personnel arrive, either on an on-call basis (typically four hour response time) or even a scheduled preventive maintenance call (typically monthly).

If a system had two processors and one failed, the on-call emergency maintenance would likely be used. If a bit failed in a main storage unit with error correction code, the failure might be allowed to remain for months until enough failures had accumulated to warrant replacement during a preventive maintenance visit. The reason this is possible is that the error correction codes in use can correct single bit errors in a single word and detect double-bit errors in a single word. Storage units are designed to prevent (or at least minimize) a single hardware failure from causing multiple bits to fail in the same word. Thus, a rather large number of bit failures can be allowed to accumulate in a storage module before the probability of two bits failing in the same word becomes appreciable.

Another approach to using extra hardware to reduce maintenance labor

cost is the use of the maintenance processor. When the host system fails, the maintenance processor can diagnose the failure much more quickly and accurately than can the maintenance man, and it does not make mistakes in procedures or forget training. The maintenance processor can read all and set many of the flip-flops in the processor, thus providing much better diagnostic capability than the old hardwired, flashing-lights consoles. It can do anything a maintenance man can do, including running the system in single-step mode, inserting data, and taking snapshots of registers—all much more quickly and accurately and under software control. Where maintenance personnel involvement is required, data can be presented to him in easy-to-understand form, without resorting to complex tables and drawings. It is entirely possible that the maintenance processor could simply type out which cards to change so that operators, and not maintenance personnel, could perform most maintenance.

REMOTE MAINTENANCE

A maintenance methodology largely made feasible by the maintenance processor subsystem is the remote maintenance approach. In this approach, a computer at a manufacturer's location is used to diagnose problems in a computer at a customer location through telephone lines if the local maintenance personnel cannot localize the problem. The objective of remote maintenance, which has been in use since 1975, is to bring expert assistance to bear on maintenance problems as quickly as possible to avert extended down time. This expert assistance takes the form of:

- down-line loading and execution of special test routines
- special dump analysis
- access to data bases of system problems with solutions
- interactive remote diagnosis by factory experts

Remote maintenance also benefits the manufacturer by reducing travel time and making better utilization of experts.

REDUNDANT SYSTEMS

The concept of the redundant system has already been introduced—a system which has two or more of every component such that if one component fails the other components can continue in operation. Redundant systems have been developed and used for many years by the defense and aerospace industries to provide high reliability systems. The

basic technology is relatively well known although research continues in this area.

Only two forms of redundant systems have been used in any numbers; these are standby systems and multiprocessor systems. Both systems continue in widespread use today. In the standby system approach, a complete second system is installed to provide service if the primary system has any malfunction. An example of this is an airline passenger reservation system. If the primary system fails, operation is switched to a secondary system which shares the communication complex and mass storage. When the primary system is operational, the secondary system is used for batch so it is not wasted. In other applications, the secondary computer simply idles until it is needed.

In the multiprocessor approach, a backup system is not used. Instead, a single system is used which has two or more of every system component, including processors, main storage modules, I/O units, and peripherals. Automatic reconfiguration capability is provided so that if a component fails (a processor for example), that component is configured out of the system, and the system continues in operation with degraded performance. Whether this degraded performance is acceptable depends on the application, as shown in the following example:

An interactive medical information query system is being designed which must have very high availability and fast response to transactions. It is determined that a one second response time is necessary 90% of the time, but a two second response time is acceptable 10% of the time. Assume that the system is designed as a multiprocessor, with two processors being adequate to provide the performance necessary to achieve a one second response time. If one processor fails, the remaining one is still able to provide the two second response time required. Only if both processors failed within one repair time would the system be down.

Redundant systems can provide dramatic improvements in system availability. Assume that a large scale processor has an availability of 0.98. If a two processor system were used to obtain the required level of performance, each processor had an availability of 0.98, and degraded performance to one processor were acceptable 10% of the time, an availability of 0.96 would result.

Notice that the availability of *full* performance actually declines for a two processor system. However, the probability of having 0.5 or more perfor-

It is becoming increasingly true that if the dp system stops, the organization stops.

mance rises from 0.98 to 0.9999 and the probability of a complete system failure is reduced from 2% to a negligible value.

If the two second response time were never acceptable, a multiprocessor would have to be configured with three processors, so that if one fails, the one second response time could still be attained.

SOFTWARE RECOVERY FROM HARDWARE ERRORS

Software recovery from hardware errors takes

many forms, including:

- correcting or rereading erroneous data from a mass storage device;
- generating duplex files or data, so that if one file is lost, the system can continue with the other;
- taking system components that have failed off-line;
- error log generation;
- fault diagnostics;
- taking checkpoint dumps to provide a restart point for a run without starting over at the beginning;
- generating an audit trail to be able to rerun or back out transactions, and
- recovery of a data base after an equipment malfunction.

The last area, recovery of a data base after an equipment malfunction, requires additional discussion, because it represents both a growing opportunity and a growing burden to user management. In earlier times, each user application was freestanding and had its own private files or data base, used in a batch mode. If the run failed due to a software bug or equipment malfunction, the run could be done over with nothing lost but the rerun time. The next step was to go to a data base management system, still in batch mode, where a single data base serviced many application programs. Although this solved many problems by eliminating redundancy and providing complete information in one place via a simple interface, it created problems by making the entire organization dependent on the integrity of the one data base. However, if the data base were compromised, it could still be recovered by batch techniques without much impact to the organization. Now, many applications use data base management software in a transaction environment, which compounds the recovery problems further.

Modern data base management systems are really quite good with respect to recovery after mainframe errors. In fact, the recovery techniques

SOFTWARE RELIABILITY PARAMETERS	
Parameter	Characteristic Value
Average number of initial program errors	1 per 100 lines of source
Average manpower to identify each error (after failure)	2 man-hours
Average manpower to correct an error	6 man-hours
Average computer time to fix an error	2 hours
Average number of errors per new system software release	1,000
Average fraction of errors due to programming mistakes	$\frac{1}{2}$

Table 2. These are typical values for parameters linked to software reliability. The last one is very interesting. It suggests that only half of all software errors come from programming mistakes; thus, no amount of emphasis on improved programming techniques can cure as many as half of the errors in programs.

specify the whole approach to the design of the generalized data base management software more than any other single constraint. For example, it is possible to specify in the schema (data base format definition) that snapshots of all changed records be made; both before and after the change. It is also typical that an audit trail be made of all transactions, and that periodic dumps be taken to establish restart points. If a mainframe error takes place, an automatic part of the restart procedure will recover the data base to just before the malfunction with no involvement on the part of the user.

The vulnerability arises when (1) mass storage media (disk packs) are damaged by operator error or equipment malfunction, or (2) the data base is compromised by software bugs. Although this is a problem in batch, it is much more of a problem in a transaction environment. The recovery process is complex, and must be performed by an expert, preferably the data base administrator. He must work closely with the operations people to recover the data base by coordinating a recovery point dump, the audit trail, and the user program (if batch). Of course, the data base is unavailable during this time and no transactions can be handled. This problem can be expected to become more severe as data systems become larger and more complex.

One approach to greatly ease recovery in the case of mass storage failure is the capability to generate duplexed files. If a file is designated as being duplexed, the system will automatically create two copies. In case of an update, the system will automatically update both copies. In case of an

inquiry, the system will determine which file copy is most quickly accessible, and then access that copy. The files need not be on the same media; one could be on a disk with the other on tape.

SOFTWARE RELIABILITY

Software is like wine—it improves with age. This is true of software functionality, but

it is especially true of software reliability. Like hardware, software exhibits an early high failure rate which goes down as time on the system accumulates, failures are encountered, and errors are fixed. Unlike hardware, software does *not* exhibit an increase in failure rate due to wearout. However, software does exhibit obsolescence which makes it less and less useful as time progresses. This obsolescence, which it has been suggested gives software a half-life of about two to three years, may be the software analog of hardware wearout.

Although the technology of software reliability is in its infancy and trails far behind hardware, semiquantitative parameters may be of interest to help size the problem. Some of these are shown in Table 2.

These parameters are self-explanatory, except perhaps the last one. This parameter shows that about one-half of all software errors result from incorrect programming. The other half result from incomplete or incorrect understanding of the applications requirements. This is important because it indicates that no amount of attention to the programming process can eliminate even as much as half the errors; therefore equal attention to the application is required.

The item missing from the above

One programmer was found to have tested a single program 56 times in one day.

list is the one which is most interesting, most elusive, and largest in cost—it is the cost of causing or triggering the failures. Indeed, if the only cost were to diagnose and correct errors, the 1,000 errors per new system software release could be corrected for 8,000 man-hours and everyone would release perfect system software. The fact is that exhaustive approaches to testing are impossible because of the many combinations of environments possible; so testing must take the form of trials or sampling, with a relatively small set of environments. The early failures in software are very easy to stimulate. But as the more obvious errors are found and eliminated, the cost of testing to trigger each error rises very rapidly.

Indeed, there is a point beyond which it is almost useless for the implementers of the software to continue testing because of their inability to reproduce an operational environment. This is much more true of system software than of tailored applications software because system software must work in a much more generalized environment where less is known about individual applications.

To circumvent this problem, testing is normally done in several stages. The first stage of testing is done at the module level by the implementing programmer. Then the modules are integrated to form a system, and the system, or alpha, testing is done, also by the implementers. Then the software is given to several "friendly users" who are willing to use the software in an operational environment and report problems—the so-called beta test. Finally, the software is released to all users and corrections are issued against it as problems are reported.

An industry rule of thumb is that each level of testing removes 90% of the existing errors. Starting with the 1% initial error rate mentioned above, and applying the four levels of testing from module through release, this 90% rule of thumb suggests that there should remain an error rate of one per million instructions. If these were encountered at random, a medium sized system executing one million instructions per second would crash once per second. This does not happen, of course, because the remaining errors are far from random; having been eliminated from the commonly encountered environments and code sequences, the errors remain in seldom used code or seldom encountered environments.

As proof of this, it is well known that systems used in a very limited environment (so called "grooved" systems)

can achieve a very high degree of reliability if appropriate effort is expended. This system software reliability of a grooved system can reach several hundred or even thousands of hours mean time between failures. Conversely, multiple environment software systems tend to have lower reliability. This multiple environment can also include a highly variable load; it is not unknown for heavy system loads to cause software failure, always at the least convenient time.

Redundancy, a principal way to improve hardware reliability, has not been successfully applied in the software area. Because of the deterministic nature of software failures, a given set of inputs which causes one copy of a software module to fail will also cause another copy to fail. The basic approach to developing reliable software is the same as it always has been—generate the code and then "test out" as many errors as possible. It has long been recognized that this is not a very satisfactory approach.

Chief programmer teams, structured programming, and top down design have all been advanced as ways of increasing software reliability as well as programmer productivity. Design review walkthroughs by independent personnel and egoless programming have also been suggested. Proof-of-correctness approaches are not to the point where they are usable on real programs. Although no one of these techniques can be considered a breakthrough in improving software reliability, each is making a contribution in that direction. Progress toward more reliable software is clearly being made because of the increased attention in this area.

In at least one area, new programming techniques may have caused regression in software quality and reliability. On-line programming, where a programmer sits at a video terminal to generate code and then runs a test against it, makes it so easy to "let the machine do it" that sloppy programming can result in an undisciplined management environment. In one site that monitors programmer activity, it was found that one programmer used 152 compile-and-execute sessions at the terminal to debug a straightforward 50 line FORTRAN program. Another programmer was found to have tested a single program 56 times in one day. Before computers were so easily accessible, programmers would perform desk debugging, which often turned up errors of a subtle nature rather easily which now must be found

by extensive and expensive testing.

The question management must answer is the following: is reliability improving fast enough to meet near term system needs? System complexity is also increasing, so there appears to be no general answer to this question. It must be answered in the context of each application, based on guidelines listed below.

FUTURE SYSTEMS RELIABILITY

Systems of the future are going to be substantially more complex than systems of today, and because of this, reliability of systems in the future is going to be even more important and more difficult to obtain than it is today.

Even while reliable operation becomes more difficult to obtain, the required level of reliability/availability is going to increase significantly. A system which is used for batch operation can get along with a down time of 6% (94% available). A typical time-sharing system can only tolerate about one-third as much down time without user dissatisfaction, giving a down time of 2% or a system availability of 98%. But a system used for time-critical transactions should be twice as good as a time-sharing system, with a down time of no more than 1% or an availability of 99%.

The following hypothetical example shows the problem in system availability that can arise in more complex systems:

The Gadget Manufacturing Co. has 10 locations (combined factory, warehouse, sales office) that build, inventory, and ship a wide variety of gadgets. Any location can accept an order for any type of gadget, although not all locations build all kinds of gadgets. Each location inventories only what it builds, but sometimes these inventories are exhausted.

When an order is received for a gadget not in inventory, an internal order is sent to the nearest location building this device. When all (or at least most) of the items for an order are received, the order is filled and shipped. However, due to internal order delays and inventory outages, this system is very slow.

Each of the locations has a free-standing, on-line order processing system which has experienced an availability of 99%. A management decision is made to integrate all 10 locations into a single distributed system to speed operation considerably to meet competition. The system is designed and implemented, and works beautifully on a



From an elegantly simple print mechanism based on this unique leaf spring hammer and advanced matrix line printing technology... print quality and reliability no other impact printer can match... plus full plotting capability at no extra cost that band, drum or chain printers can't provide at any price.

PRINTRONIX..today's 'First Family' in medium speed impact printers.

In 1976, Printronix introduced the first printer designed to fill the need for medium speed impact printing at practical prices. The unique concept and design of this matrix impact line printer brought unequalled print quality to impact printing. Its elegant simplicity, with up to 50% fewer parts than band, drum or chain printers, also established proportionately higher levels of reliability. Today, they are available in 150, 300 and 600 line-per-minute models priced about the same or less than medium speed band, drum or chain printers. They're warranted for one full year while 90 days is typical for others. And they all offer you one feature band, drum or chain printers can't: full graphics plotting capability. Get acquainted with our family. You might be captivated by their cost/performance and cost of ownership attributes. They're all up for adoption. Printronix, Inc., 17421 Deegan Ave., P.O. Box 19569, Irvine, CA 92713. (714) 549-8272. TWX: (910) 595-2585.

PRINTRONIX

150 lpm P150

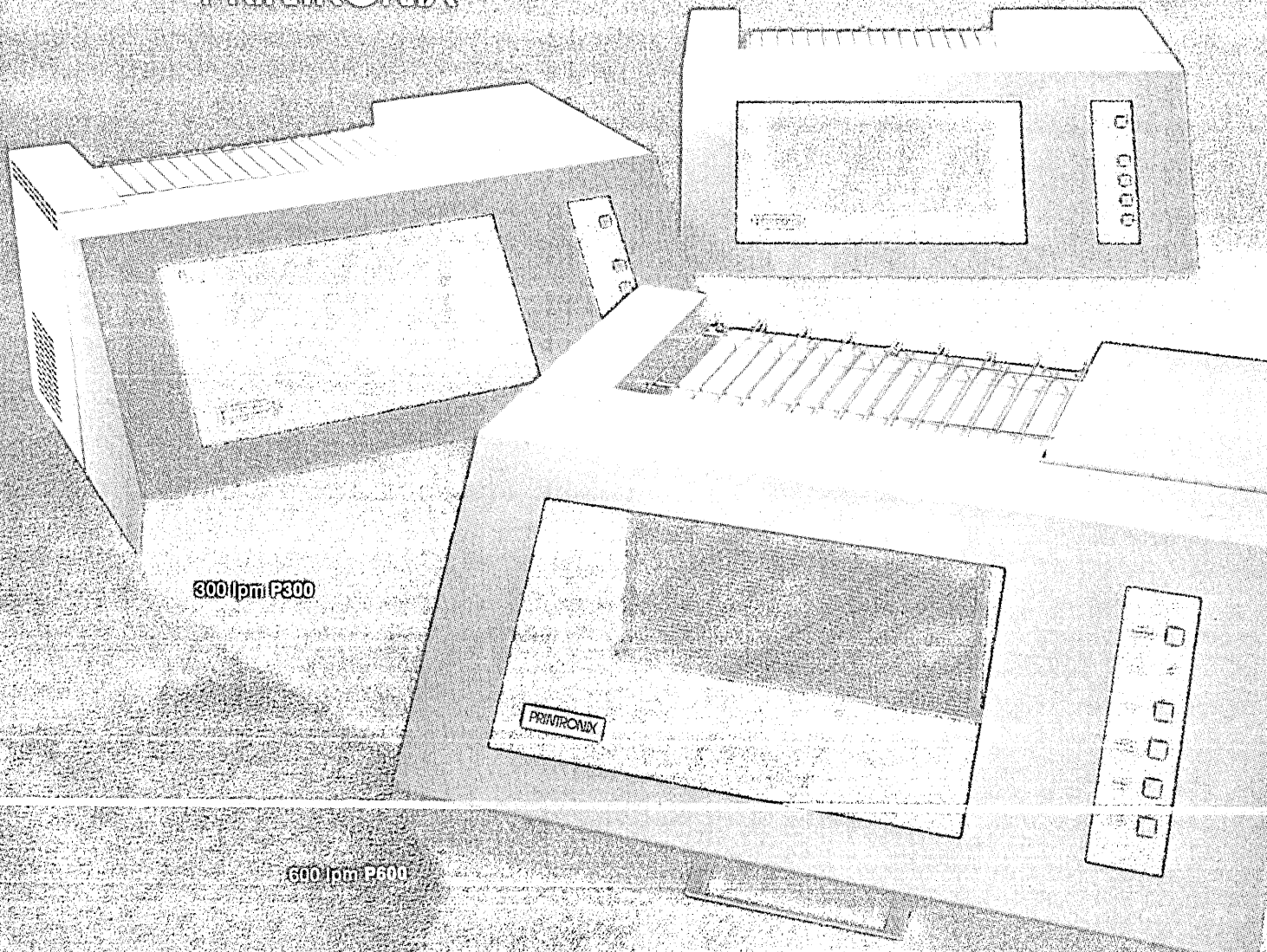

300 lpm P300

600 lpm P600

Circle 27 on Reader Card

Is reliability improving fast enough to meet near term system needs? Maybe.

functional basis. However, reliability is a major problem because all 10 sites must be operational for the system to work, and at least one site is down quite often.

An outside consultant is called in to solve the problem. After listening to the problem, he calculates the availability of the entire system on the back of an envelope

$$\text{System Availability} = (0.99)^{10} \approx 0.90$$

"There is no way," he states, "that this system can be reliable enough to be useful without major improvements. The reliability of each node must be substantially upgraded through the use of

APPORTIONMENT OF NET SYSTEM AVAILABILITY BUDGET

Component	Availability	Down
Hardware	0.993	0.0067
Software	0.993	0.0067
Other	0.993	0.0067
Total	0.980	0.0200

Table 3. If the major system components each have an individual availability of 0.993 (equivalent to being down less than 7 hours every 1,000), the system still is likely to be down 2 hours of every 100.

HARDWARE COMPONENT AVAILABILITY ALLOCATION

Hardware Component	Availability	Down
Processor and I/O	0.9984	0.0016
Main storage	0.9984	0.0016
Mass storage	0.9984	0.0016
Peripherals	0.9984	0.0016
Total	0.9933	0.0067

Table 4. To achieve the 0.993 availability of the hardware component, the availability of each individual hardware subcomponent must be far better than 0.993.

redundant techniques, and the system in general must be made fail-soft so the failure of one or two nodes will not stop the rest of the system."

This is done by duplexing certain critical equipment and files at each site, and providing the ability to use alternate sites or to queue orders to a particular site if that site is unavailable. Thus, this hypothetical problem is solved satisfactorily.

A system with 95% availability (i.e., down 30 minutes every 10 hours) is probably unusable for anything but local batch. A more realistic absolute minimum system might be 98%. This net system availability might typically be equally apportioned to the major system components as shown in Table 3, where each component must have an availability of 0.993.

If the hardware component were subdivided into subcomponents, each with an equal share of the availability budget, the result would be as shown in Table 4, with each component having an availability of 0.9984.

The minimum acceptable reliability for a processor and I/O becomes, then, one hour down time (a typical processor mean time to repair) every 600 hours of operation. In actual practice, processors usually approach 1,000

hours mean time between failure. However, consider a situation where 10 disk drives are available, and all 10 are required for operation. The availability requirement for each disk becomes 0.99984, or one hour down time for 6,000 hours of operation, an objective which cannot be met by present day equipment. However, if an 11th disk drive were provided so that the repair time would be reduced from one hour to three minutes (the time to move a disk pack) the mean time between failure requirements of the disk drive is reduced to 300 hours, a goal which can be easily exceeded.

If a higher reliability system were desired, where the minimum acceptable availability were raised to 0.99, the hardware availability budget for this example would become 0.9967, or one hour down time for every 300 hours of operation. Now the processor reliability requirement becomes 0.9992, or one hour down every 1,250 hours. At this point the adequacy of the reliability for a single processor becomes marginal, and a second redundant processor should be used. The availability A of a several processor complex, one of which must be operational, is given by the formula:

$$A = 1 - \pi(1 - A_i)$$

where A_i is the availability of each individual processor. Assuming a two processor complex with each having an availability of 0.999, the availability of the complex is 0.999999, or less than one minute down time every 10,000 hours, increased by redundancy from the one hour down per 1,000 hours. Thus, redundancy is a very powerful tool for increasing availability.

Although availability is greatly improved by redundancy, all is not beautiful. One processor will be down every 500 hours on the average, degrading system performance by approximately half and requiring a maintenance call. If on-call maintenance were used instead of on-site maintenance, with a mean time to repair of five hours (four hours travel plus one hour repair) the availability would still be 0.99997. However, the degraded performance would now exist five hours out of every 500, or 1% of the time.

It should be noted that a main storage module with error correction code (a form of redundancy), even as large as 10 million bytes, has a mean time between failure of about 4,000 hours. Thus, it easily exceeds the requirements for a system availability of 0.99 by a factor of three. The other serious limiting factor is software. *

GEORGE A. CHAMPINE



Dr. Champine is the director of advanced systems for large scale commercial computer systems at Sperry Univac. In this position he is responsible for the

technical planning, design and analysis of systems beyond those currently committed to production. He is also responsible for design and management of large special projects using commercial equipment. In his 20 years with Sperry Univac, he has held several technical and managerial positions in the software and system design fields. His most recent prior position was senior staff consultant, where he was responsible for managing the advanced technology program for large scale computer systems.

Dr. Champine is also an adjunct Professor at the Univ. of Minnesota, where he teaches courses in analysis of information systems and engineering project management.

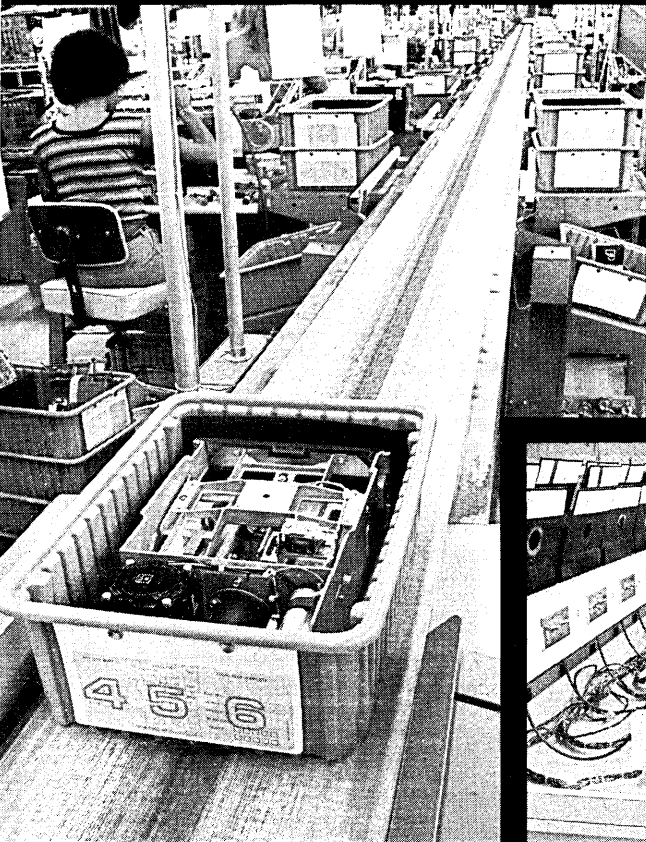
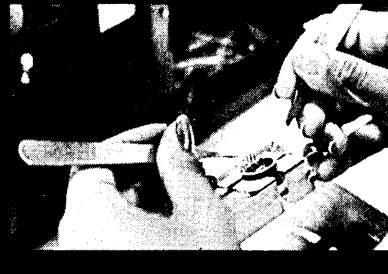

They work for Shugart.

That's why Shugart works for you.

Concentration. We do one thing well. Our corporate charter is to make high quality, low cost disk storage devices. We concentrate all of our human and material resources on achieving this goal. This specialization is the key to our success in becoming the recognized leader in floppy disk technology and delivery.

Capacity. Success as a supplier of peripherals to the OEM equates with delivery of large numbers of cost-effective products at high quality levels. At Shugart, we have been fortunate in attracting highly dedicated people with the expertise to build our manufacturing capacity into the largest in the industry. In 1973 (our first year) we delivered 1,000 floppy drives. This year deliveries will exceed 200,000 units. To successfully handle this dramatic growth, we have built more than 150,000 square feet of production facilities with the most modern high speed conveyorized assembly systems. But it is our people who really make it all happen.

Leadership. More dedicated people. More concentration. More technology. More products. More capacity. That's why more OEM's select and trust Shugart.

Shugart. The leader in low cost disk storage.

 **Shugart Associates**

415 Oakmead Parkway, Sunnyvale, California 94086
Telephone: (408) 733-0100
Europe Sales/Service: 3, Place Gustave Eiffel, Silic 311
94588 Rungis, France Telephone: (1) 686-00-85

CIRCLE 89 ON READER CARD

Baud rate switch — Switch from 110, 150, or 300 baud to 600 or 1200 baud transmission easily. Just flip the convenient switch and the terminal easily adapts to your communication speeds.

Front panel accessibility — All the normally used operator controls are organized into functional groups and logically arranged for maximum operator convenience.

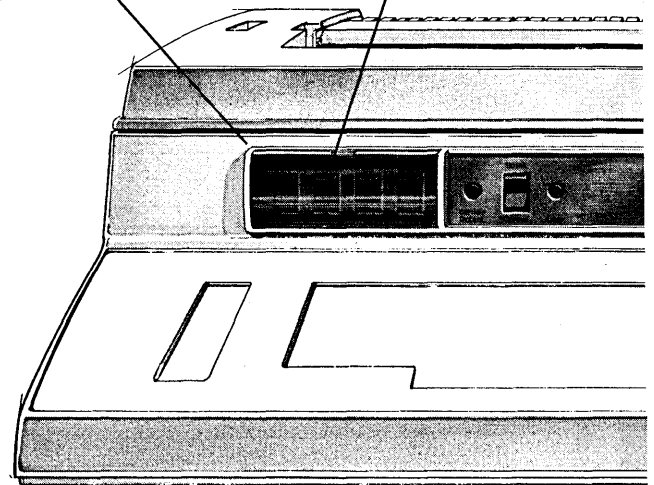

Introducing the smart daisy especially for the

It's called the Sprint 5. And it's from Qume.

That's right. Qume.

We've established quite a reputation in the word processing business. A reputation for letter quality print. And because of that, we didn't want to simply attach a keyboard to a printer and present it to the computer industry as a full blown terminal.

So we designed our Sprint 5 daisywheel terminal from the ground up to meet the needs of the computer industry. Complete with our famous print quality. And 55 cps speed.

Qume's smart microprocessor gives the Sprint 5 many capabilities not found in conventional terminals. Such as a powerful command set, self-diagnostics, memory storage of tab settings, and forms control programs.

Smart microprocessor logic — You get flexible character spacing, precise plotting resolution, and smart multi-direction carriage slewing. Not to mention high quality printing. Fast.

Interchangeable character sets — We have over 50 different character sets and typestyles. They're easy to change and include international characters, APL, and scientific symbols.

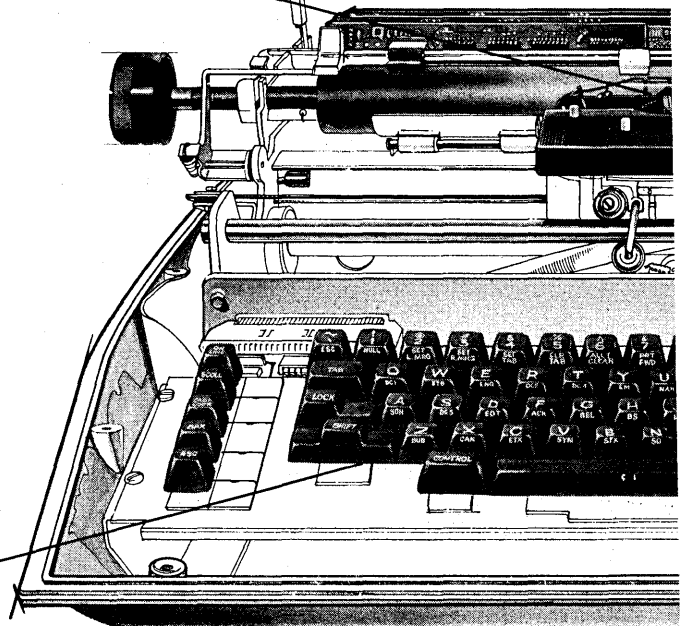

Comprehensive command set — 59 powerful user oriented commands provide format flexibility. And to make it even easier, commands are printed on the keycaps.

TwinTellect™ option — Want to use a special printwheel? Just switch on TwinTellect when you install the printwheel. Sprint 5 electronics provide the coordination between code and print characters. Available only from Qume.

Dynamic positioning — Create graphs or justify your text easily. With switch selectable 10 or 12 characters per inch spacing. Plus controlled spacing of 1/20" horizontal and 1/48" vertical.

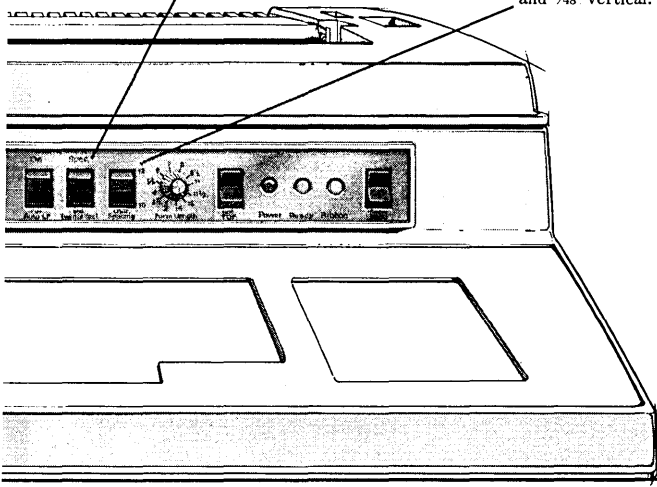

wheel terminal designed computer industry.

Serial or parallel interface — Sprint 5's can provide a standard serial RS232C interface to your system. In addition, the keyboard version is available with DC current loop interface, and the printer version is available with DC current loop or parallel interface.

Multicolor ribbons — over 15 different ribbons (10 color choices) to color your messages. Easy to handle cartridges with carbon or fabric multicolor ribbons.

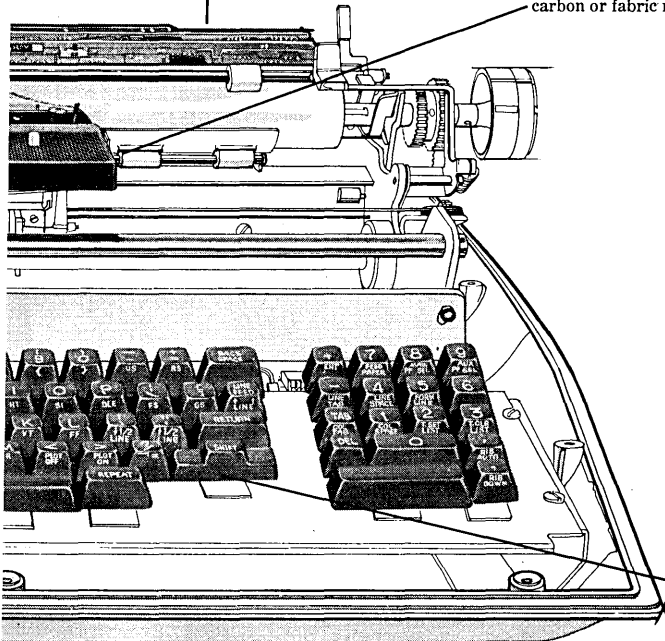

Surprisingly enough, however, the Sprint 5 costs no more than competitive terminals.

Obviously, a product that does much more but costs no more is a better buy.

And when all is said and done, that may be Sprint 5's most outstanding advantage.

For further information on how the Sprint 5 can give your computer letter quality output, contact: Qume Corporation, 2323 Industrial Parkway West, Hayward, CA 94545 or phone Lee Cannon, (415) 783-6100, Extension 338.

Self test — Internal self-diagnostic routines can be initiated from the keyboard or from remote sites.

Qume[®]
the printed word



DEC[®] never had it so good

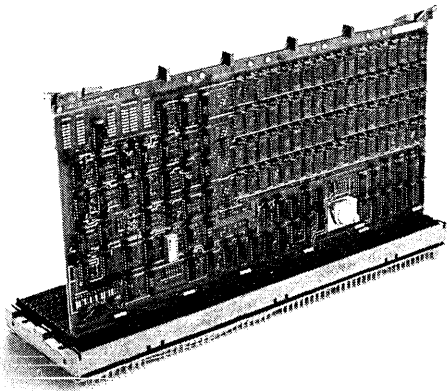

DEC's semiconductor memories:

If you want to, you can always buy semiconductor memories for your DEC mini's from DEC.

But they tend to be bulky (16K bytes to a board for some mini's and *five* boards for their ECC unit).

And you probably already know about DEC's pricing structure on additional memory.

®Registered trademark of Digital Equipment Corporation

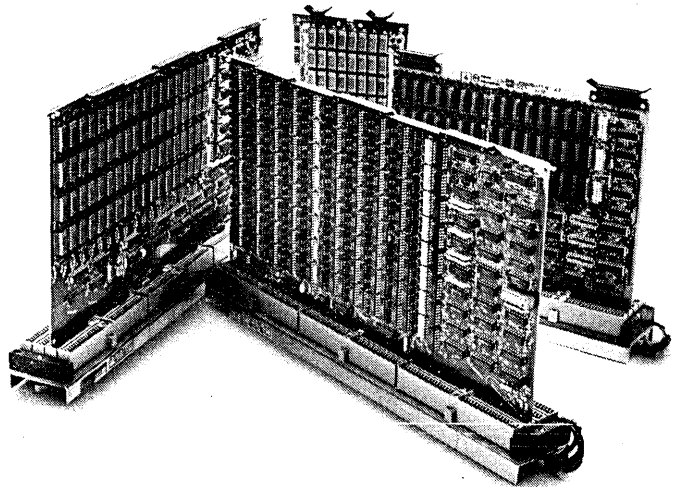

Plessey's:

We offer a complete family of DEC-compatible semiconductor memories.

64K, 128K and 256K bytes (with ECC) for the DEC PDP-11[®] series. 128K words for the PDP-8A[®]. And 64K bytes for the LSI-11[®], PDP-11/03[®] and our own Micro-1.

Our plug-compatible memories cost less and run faster than DEC's. Reliability is ensured through 100% component burn-in and 100% board testing. Each and every memory is then run in the minicomputer it was designed for before we ship it out the door.

This kind of care has made us the largest independent supplier of DEC-compatible peripherals. Our product line presently includes add-in/add-on core and semiconductor memories, cartridge disc systems, floppy disc systems, mag tape systems, complete computer-based systems, and a wide variety of backplanes, expansion chassis, and other accessories.

We're the only real alternative to DEC for all your miniperipherals, a complete single source. For all the details, please contact the nearest Plessey sales office today.



Plessey Peripheral Systems

17466 Daimler, Irvine, California 92714, (714) 540-9945

A THEORY FOR SOFTWARE RELIABILITY

by Michael G. Walker

Exaggerated claims are being made for structured programming, top-down design, stepwise refinement, chief programmer teams, and other software development techniques. Articles containing the claims have two commonalities. First, they are anecdotal and portray the results of a single experience: "All Indians walk single file. At least the one I saw did." Second, they present no rationale. Why does the proposed programming technique work? Why should it work in other environments?

To put these claims into perspective, a theory of the management of software production is needed. The following theory provides a rationale. It attempts not only to explain how some programming techniques increase reliability, but also why identical techniques fail in similar environments.

However, the theory is radical. It holds that changes in techniques are *marginal* to production improvements, and that organizational structure, and therefore the management of structure, are the cardinal factors.

Theorem: Organizational structure is the prime determinant in producing reliable software.

Corollary 1: Noise is the measure of software reliability.

Corollary 2: Organizational structure provides noise filtration.

Corollary 3: Structural demands increase with software complexity.

The theorem and corollaries demand some definition of terms, and it turns out that the most appropriate definitions come from three different fields. The primary contributors are a sociologist, James D. Thompson (*Organizations in Action*, McGraw Hill, New York, 1967); an engineer, Glenford J. Myers (*Software Reliability*, John Wiley & Sons, New York, 1976); and a communications theorist, J.R. Pierce (*Symbols, Signals and Noise*, Harper & Row, New York, 1961).

Structure: This definition comes from Thompson and refers to the patterning and differentiation of internal relationships within an organization.

Reliable Software: This comes from Myers and refers to a probability.

Software reliability is the probability that software will execute correctly over a period of time, weighted against the cost of each error.

Noise: This comes from Pierce with an assist from Myers. According to Pierce, noise is any undesired disturbance in a system. Myers refers to software errors as software systems results that users do not reasonably expect. Therefore, noise is a disturbance in a software system, either an omission or commission, which users do not reasonably expect.

Software Complexity: This comes from Myers and refers to both the quality and the quantity of the relationships among the components of a software system. Myers contends that software complexity can be minimized by independence, hierarchy, and making connections apparent.

Reliable software is the desired outcome of software system development. The reliability of a software system is determined by the absence of noise. Noise filtration then is a primary aim in the production of software systems; and the management of noise filtration is the most significant task in producing reliable software.

Why then is structure the prime determinant in noise-free software? Why not simply write noise-free code? The interrelationships of three factors, tech-

nological complexity, communications costs, and information translation, must be addressed before the question can be understood. Again, these terms can best be understood in an interdisciplinary context.

Thompson tells us that all technologies involve specialization. And the more complex a technology is, the more specialized are its components. (See Fig. 1.) These specialized and interrelated components must be coordinated. Thompson has devised a relationship between interdependence and coordination. (See Table 1.) He has found that the costs of coordinating these specialized components increase with the specialization of the components, according to a curve much like that of Fig. 1. These coordination costs are primarily costs of communication. Therefore, the costs of coordination are a function of technical complexity.

Thompson observed another interesting phenomenon. Communications costs can be reduced by grouping interdependent components, by managing structure. Those organizational components which are more interdependent need more communication. Any grouping which facilitates communications reduces communications costs and also reduces noise.

Myers tells us that the nexus of software production is information translation. (See Table 2.) Production of software is the translation of a problem into various intermediate solutions until a detailed set of instructions is produced. Translation points occur wherever the media and hierarchy of information change. Myers also tells us that the single major cause of software errors is translation noise.

When a typical system's production effort is pictured as in Table 2, we can see the progression of information translation. Objectives to requirements, requirements to design, and design to code are a bare minimum of steps. Each step is an instance of data translation from one medium and hierarchy to another. The medium of the objectives document leads to the medium of the specifications document. As each successive translation is made, communication is necessary. The more effective the

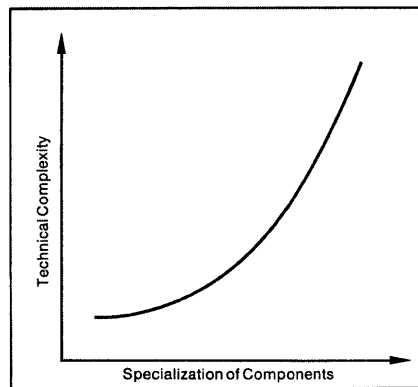

Fig. 1. As technical complexity increases, so does the specialization of a system's components. As technical complexity and specialization increase, so does the cost of project coordination.

Managing software system production is a search for effective structures.

communication, the more reliable the software is likely to be.

As software becomes more complex there are more interrelationships to translate. Therefore, more burden is placed upon effective communications. And as Thompson has shown, structure is the vehicle for controlling communications. The need to manage structure thus increases if communications are to be effective.

What can we say specifically about structure? What kinds of structures improve communications? Thompson says that the technology dictates the appropriate communications type and the appropriate structural type; that is, that different types of technology require different structures to coordinate communications. The most complex types of technology require the most flexible coordinating structures. Such technologies are characterized by the transmission of new information during the process. Each component impacts and is affected by all other components. High technology thus requires a most flexible interactive structure, a structure which changes as the information flow changes.

The management of this type of structure, then, is the primary task in producing reliable software. This management requires an understanding of the software production process and an ability to adapt to its demands.

THE TRADITIONAL VS. THE NEW

Managing software system production thus becomes a search for effective structures. The problem is one of finding a structure which is in tune with a given technology. Software production occurs in a complex technical environment, an environment characterized by constantly changing user demands. It is an uncertain environment—uncertain concerning language tools and hardware capabilities. Finally, it is an environment characterized by inadequate management devices. It is not surprising that the search for appropriate organizational structures has been difficult and often disappointing. It is also not surprising that the production of software is such an arduous and expensive task.

The traditional structure for managing software production was borrowed from engineering and rests upon several assumptions. (See Fig. 2.) It assumes that production can be segregated on the basis of occupational groups and sequenced by developmental phases: first phase analyze, second phase code, third phase test, and finally implement. Therefore, traditional structure groups analysts together, coders

INTERDEPENDENCE OF COMPONENTS VS. TECHNIQUE NEEDED TO COORDINATE COMPONENTS

Interdependency	Coordination Technique
Simplest (static environment; little communication)	Simplest techniques (static standards)
More advanced (anticipated changes; more communication)	Advanced techniques (plans for change)
Most advanced (constantly changing environment; communication must flow with changes)	Radically adaptive (changeable organizational structures; structure a function of technical demands)

Table 1. Fixed organizational structures employing straightforward control techniques may be adequate for the development of simple software products. At the other extreme, no fixed structure may be adequate to control the development of highly sophisticated software.

SOFTWARE PRODUCTION CYCLE IN TERMS OF INFORMATION MEDIA AND INFORMATION HIERARCHY

Translation Phase	Information Media	Information Hierarchy
Systems concept	Objectives document	Broad overview
General design	Design specifications	Requirements
Detailed design	Systems components	Natural language studies
Program code	Programming language	Computer language structures

Table 2. Noise occurs when information translation between project phases doesn't go right. Cutting down on that noise is the most significant task in software production.

together, and testers together. Traditional structure attempts to control the translation of information between groups employing standardized documentation.

The traditional structure works well in a relatively static and certain environment. If users' needs don't change constantly and if hardware and software tools are "known" then standardized documents can successfully filter translation noise. However, as software systems become more sophisticated, the environment becomes more dynamic. Control by documentation is no longer responsive. The traditional groupings do not work. The history of sophisticated software projects of the late '60s and early '70s reveals, in overruns, the problems of traditional structure.

Structured programming has been explored as an alternative. However, structured programming is essential-

ly only a coding technique. Its utility is primarily within the coding phase. Structured programming is an attempt to write programs for people, not for machines. Such techniques are extremely welcome and provide an excellent tool for communications. However, the total development cycle is not affected. Structured programming can and has been incorporated into traditional structures, and has improved the communications within them. However, structured programming does not operate as a filter at all translation points. In those environments in which noise is introduced in the design stages, structured programming will not ensure reliability.

Design technologies have also been investigated. Structured design, composite design, stepwise refinement and top-down design are examples. These design technologies are attempts to facilitate design communications just

THE TALLY PRINTER TERMINAL

Control 42 functions via the keyboard or the program

The Tally T-1612 Printer Terminal is designed for the user. It's loaded with functions and features. In addition to 42 programmable functions, which are available through the keyboard or through the user program, you get features like outstanding print quality, optimized bi-directional printing at 160 cps for bonus throughput, quiet operation for office use, lots of forms control conveniences, table top or pedestal mount and outstanding reliability that translates into low cost of ownership. And plenty more.

Unique features include six selectable type fonts in upper and lower case, LED column/line indicator, non-destructive memory providing pre-selected configuration on power up and 1k buffer standard (up to 4k optionally).

The Tally T-1612 is also available as a Receive Only printer. Both versions sustain a full 1200 Baud transmission rate. Or you can select 300, 600, 2400, 4800 or 9600 Baud operation.

Tally Corporation, 8301 S. 180th St. Kent, WA 98031.
Phone (206) 251-5500.

TALLY[®] **PRINTERS** **WORLDWIDE**

OEM SALES OFFICES
Boston (617) 272-8070
New York (516) 694-8444
Chicago (312) 325-9788
Los Angeles (213) 378-0805
Miami (305) 665-5751

San Jose (408) 247-0897
Seattle (206) 251-6730
San Antonio (512) 733-8153
Washington, D.C. (703) 471-1145
BUSINESS SYSTEMS SALES
Orinda, CA (415) 254-8350

CIRCLE 68 ON READER CARD



The history of sophisticated software projects in the late 1960s and early 1970s reveals the problems of our traditional structure.

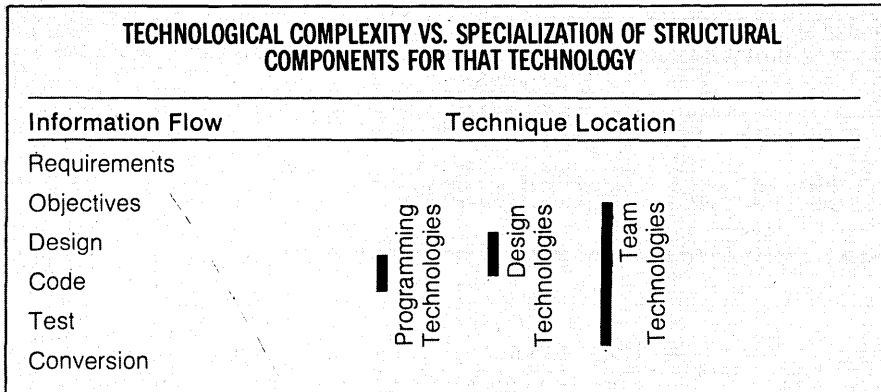

Fig. 2. The new programming and design technologies work well within project steps, but don't help to eliminate faulty translation between steps. So far, the team techniques are the only ones which aid there.

as structured programming facilitates coding communications. Design technologies cover the general and detailed design stages and thus impact more translation points than structured programming. These design technologies can also be incorporated into the traditional structure. However, the total development cycle is not impacted by

these design technologies either. Effective management of noise filtration over the entire development cycle is still not accomplished.

Team technologies are attempts to restructure the complete development cycle. Chief programmer teams, egoless programming teams, and specialist teams are variations of the technique.

The total developmental cycle is conceived as a continuous process. As many developmental phases as possible are completed by the same team. Therefore, translation point communication is intrateam communication, and intrateam walkthroughs are able to provide valuable translation point noise filtration.

If, as this theory proposes, the production of reliable software is a problem in noise filtration, and the management of this filtration depends upon discovering successful organizational structure, then team techniques seem the most innovative method of dealing with noise over the total production process. Therefore, the team structure should be a vital component in the managing of software production.

IN THE END

It should be obvious why the newer programming technologies differ in their effectiveness. Most of these new technologies apply to intramedia tasks. They radically improve the process of software production up to translation points. However, only those structures which filter noise at translation points can be expected to radically improve software reliability. Techniques can and do help. Structure, however, is the prime determinant.

Organizations that manage structure to reduce communications costs will also produce more reliable software. This software will be less prone to the noise introduced at translation points, noise which stems from software complexity. Therefore, as software becomes more complex, the management of structure will take on ever greater significance for organizations applying computer technology. *

MICHAEL G. WALKER



Dr. Walker is currently a senior computer scientist at Computer Sciences Corp., where he is responsible for formulating software engineering

policy for the Systems Div. His last post was as a senior systems analyst for the U.S. Congress House of Representatives. Prior to that assignment, he had eight years of dp experience working for Auerbach Associates, North American Rockwell, Informatics, and the U.S. Army.

computer accessories corp.
 211 new york avenue • huntington, n.y. 11743 • (516) 421-0929
 tlx / twx 510-226-7835

computer accessories corp.
 211 NEW YORK AVE. • HUNTINGTON, N.Y. 11743 • (516) 421-0929

Your low-cost, dependable source for same day service on Data Processing & Word Processing Equipment & Supplies

- Magnetic Tapes • Cassettes
- Cards • Cartridges • Flexible Disks • Disk Packs • Paper & Mylar Tapes • Roll & Continuous Forms • Thermal Printer Paper Binders • Cabinets • Containers • Racks • Reels • Vertical Format Tapes • Punches • Splicers • Automatic Winders

Your order received before noon can go out the same day.

Circle reader service card number for free catalog, available direct from the manufacturer.

MODESTY ASIDE, THE TALLY T-2000 IS THE MOST RELIABLE (AND LOWEST COST OF OWNERSHIP) LINE PRINTER YOU CAN BUY.

Tally's long term reliability is unmatched in the printer industry. Extended usage does not affect performance. Even after years of operation. Field tests prove it! And this steadfast reliability is from a 200 line per minute printer that doesn't require lubrication or adjustments of any kind. No preventive maintenance is ever needed; there are no duty cycle limitations.

TALLY[®] **PRINTERS** **WORLDWIDE**

OEM SALES OFFICES

Boston (617) 272-8070
New York (516) 694-8444
Chicago (312) 325-9788
Los Angeles (213) 378-0805
Miami (305) 665-5751
San Jose (408) 247-0897
Washington, D.C. (703) 471-1145
San Antonio (512) 733-8153
Seattle (206) 251-6730

BUSINESS SYSTEMS SALES

Orinda, CA (415) 254-8350

Tally's "up-time" performance means extremely low operating costs. Couple this with our low purchase price and it adds up that the Tally T-2000 offers the **lowest cost of ownership** available.

The reason for this superior reliability is the proven and patented print comb mechanism. Based on the simple design premise of moving light masses over short distances, it's impervious to wear or malfunction. As a bonus, it delivers page after page of outstanding print quality.

Tally Corporation, 8301 S. 180th St. Kent, WA 98031. Phone (206) 251-5500.

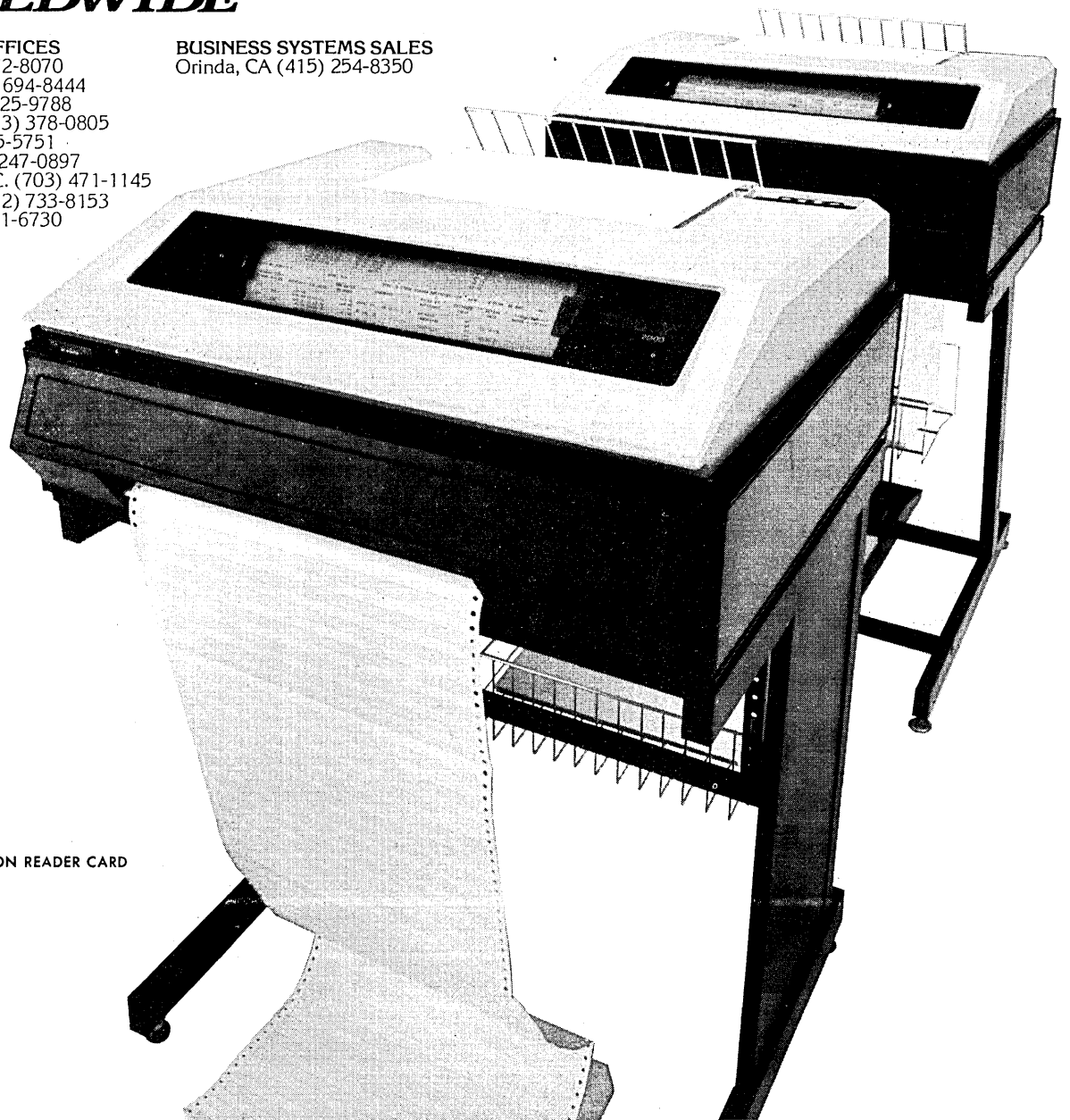

CIRCLE 135 ON READER CARD

I DIDN'T BUY JUST A TREE

... I bought the years of time it took to grow.

And when you buy a CRT display module from Motorola, you get the years of time and experience it took us to grow . . .

The years of development engineering and direct contact with OEM terminal manufacturers that it took to grow more than 65 current models . . . choices of CRT size, character density, scan frequency, type of drive, specifications quality, and price . . .

The years of investment and determination that it took to grow our manufacturing operation from ground zero to a smooth-running production facility . . .

The years of careful component evaluation, quality control, life testing and field experience it took to grow a solid, and justified, OEM confidence in our CRT modules . . .

The years of experience that comes from growing up serving the display terminal industry. You benefit from experience . . . our experience.

Call the sales office in your area:

Sunnyvale, California (408) 744-1277
Tustin, California (714) 838-5621
Carol Stream, Illinois (312) 690-1400
Dallas, Texas (214) 233-2006
Salern, New Hampshire (603) 898-5921
Shrewsbury, New Jersey (201) 544-9541
Baltimore, Maryland (301) 821-0062

Overseas, ask for International Sales Manager, Carol Stream, Illinois (312) 690-1400.

Model M4408
15", 132 x 46 format
6072 characters

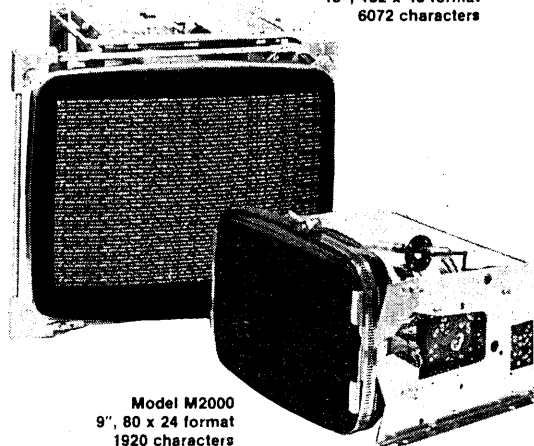

Model M2000
9", 80 x 24 format
1920 characters

BENEFIT FROM EXPERIENCE ... OURS



MOTOROLA INC.

Data Products 455 E. North Ave., Carol Stream, Illinois 60187

Lexitron now offers all the features that made our systems famous...

It means the utmost in office efficiency and productivity. Typing time slashed. Revision time pared to a bare fraction. Proofing virtually eliminated — yet with no mistakes! The family of Lexitron VT 1000 Systems handles everything from routine correspondence to the most complex and specialized documents — faster and at lowest possible cost.

Now with the added advantages of mini-floppy disk storage media.

Lexitron's new VT 1200 models feature a single floppy. You can store tab-settings... make detailed document descriptions on more than one index page.

Lexitron's new VT 1300 model comes with dual mini-floppy disks.

That lets you duplicate disks... assemble and rearrange documents... edit new material while multi-page documents are continuously printed.

Great news for current Lexitron owners! You can easily and inexpensively convert your system to floppy disk media (with data transferred from cassette overnight.) Or you can continue to enjoy the particular advantages of cassette media — with full Lexitron support. You can even operate with both media!

Now everyone can benefit from exclusive Lexitron features — plus advantages of floppy disks.

Find out more about the new VT 1200 & 1300 models and how they

can help you — at your nearest Lexitron branch, or write: Lexitron Corporation, 9600 De Soto Ave., Chatsworth, Ca. 91311.

Lexitron

CORPORATION

9600 De Soto Ave.
Chatsworth, CA 91311

I'm interested in learning more about your new VT 1200 & 1300 models.

Name _____

Title _____

Company _____

Address _____

City _____

State _____ Zip _____

plus the advantages of floppy disks!

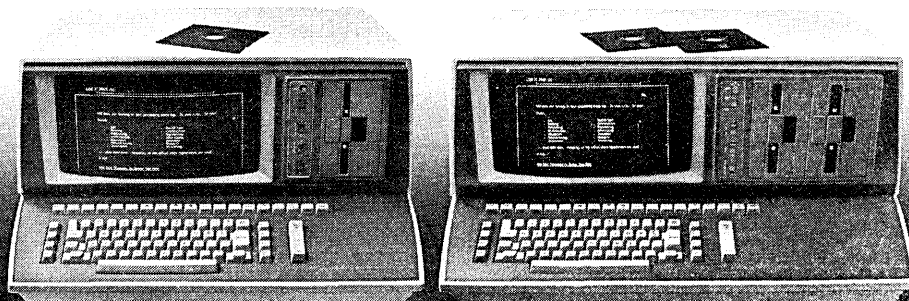

A Raytheon Company

Input to improve data handling output, from Peripheral Dynamics Incorporated

PDI Intelligence

Number three of a series

From work data collection, to voting, to lotteries, PDI makes a manually-fed reader for the application.

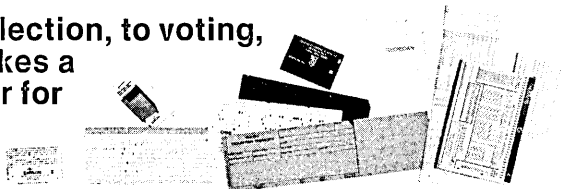

PDI now has a full range of standard data collection equipment to satisfy rapidly-expanding vertical markets that require the reading of punched cards, mark-sense cards, badges, and special forms. We currently offer six basic types of equipment comprised of 14 different models for such applications. These include *One-At-A-Time Readers*, *Card/Badge Readers*, *Type 3* and *Type 5 Badge readers*, and *All-Weather Badge readers* (see adjacent story). In addition, we have three new types of readers under development and our Applications Engineering Department comes up with new variations to our standard models almost on a monthly basis.

You name it, we handle it. Our 14 manually-fed reader models, on a collective basis, handle stock thicknesses that vary from .003" (newsprint), to .007" (standard card stock), to .010" Mylar and .030" badge stocks. In terms of width we handle 2" to 4½" in paper stocks, which includes standard cards, to 3½" in badge stocks. Document length is something else again. We can handle down to 22 columns up to any-

thing that's practical. Would you believe 3½ feet!

Pick a color, any color . . . We are exceedingly proud of the mark-sense reading mechanism used by these readers. Recent studies show it to be one of the most capable on the market. In the current color chart of OCR inks published by Sinclair and Valentine, for example, 46 different manufacturers of readers are listed in relation to the sensitivity of their readers to 36 different colors. Only three manufacturers are shown to make equipment insensitive to all colors, and PDI is one of them! In our mind, and we hope yours, this proves that our capability exceeds that of most of the "traditional leaders."

As you like it. Our 14 models of manually-fed card, badge, and document readers can be furnished in configurations ranging from a complete unit with current loop or RS-232 data communications interface, through to "mechanism-only" units. We'll be happy to send you data, along with the Sinclair and Valentine color chart.

Circle Number 101 on Reader Service Card

Something for the OEM, the best automatic card readers available.

Over the years, PDI has evolved a line of automatic card readers that suit virtually any OEM data processing requirement—from routine applications to sophisticated systems. We offer models for reading punched-hole cards in 80-column formats, or mark-sense cards in 40- or 80-column formats, 51 to 80 column length, and Delta

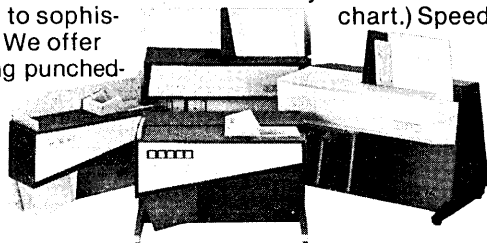

head models that read both. (Those mark-sense readers, by the way, read *any* color card, see adjacent story on Sinclair and Valentine color chart.) Speeds range from 150 to 600 cards per minute. Configurations include table-mounted models and rack-mounted models. Reliability is second to none!

Circle Number 103 on Reader Service Card

WE'VE EXPANDED. AGAIN!

In order to accommodate our steady growth, PDI has moved its marketing and sales offices into new facilities at the Whitpain Office Campus in nearby Blue Bell, PA. Our address is, Peripheral Dynamics Inc. Sales & Marketing Offices Whitpain Campus 1730 Walton Road Blue Bell, PA 19422

Our phone number remains the same, 215-277-8484.

All-weather reader uses PDI mechanism.

Neither rain, nor snow, nor forgetful operators can stay this card/badge reader from doing its appointed job. That also goes for dirt and hazardous environments.

We are speaking of an all-weather reader PDI makes for a major oil company as part of a new terminal-automation/information system.

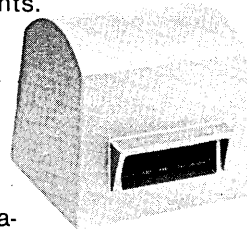

This new automated bulk-terminal (ABT) system was recently described in NATIONAL PETROLEUM NEWS (NPN). The article points out that the oil company looked far and wide (over 40 models) before finding a reader that met their spec of a Class 1, Group D, UL rating for a hazardous area. They found it at PDI.

In addition to its capability for operating safely in hazardous atmospheres, this new card/badge reader had to be weather proof because it is installed outdoors at bulk terminal sites. Among its other unique capabilities is the fact that dirt on the card will not affect reader operation and a forget-me-not feature that makes it impossible for the truck driver to leave his card in the mechanism.

For a reprint of the NPN article, circle the number below.

Circle Number 102 on Reader Service Card



Peripheral Dynamics Incorporated

Sales & Marketing Offices • Whitpain Campus
1730 Walton Road • Blue Bell, PA 19422

The techniques are the important part, and they are based on some important observations.

EXPRESS TESTING

by Lawrence H. Cooke, Jr.

Does your installation suffer from the "lack of test time" syndrome? A rather painless cure is available to most third generation computer installations; even companies that are in the main very sophisticated in testing methods may benefit. The techniques have been proven in the field and are quite practical. Using them in our installation achieved the following results in a three year gestation period:

- 600% increase in tests per programmer with resources held constant
- 80% decrease in average turnaround time
- programmer complaints about test time disappeared
- operational costs remained constant

Nor did the results require "Buck Rogers" technology to achieve.

The setting in which these gains were realized (Midlantic Bank, West Orange, N.J.) was a dynamic one. This IBM shop, with a 370/158 and 370/145, was converted from DOS to OS during the period. It used VM/370 and CMS interactive facilities for part of the conversion, and presently uses ROSCOE and Librarian (both from Applied Data Research) under OS/VS1.

These products and this hardware are not essential to attain the benefits described. Any third generation hardware with disk or drum secondary storage may be used. Display terminals, though they will augment the benefits, are not strictly required either.

MODIFYING PROGRAMMER BEHAVIOR

The techniques are the important part, and they are based on some straightforward observations, such as that programmers spend the bulk of their time testing. In studies of many installations, a 20% design period, 30% coding period, and 50% testing period is typical—in spite of advanced programming techniques. Although the numbers may vary in any particular shop, testing is always a major time consumer. Fig. 1 illustrates the relationships we have found to hold between test turnaround time and delivery of a finished product.

The point of the figure is to illus-

trate what we all intuitively feel: that adding a few hours to the average turnaround figure can result in weeks or months of delay in product delivery. Thus even modest gains in turnaround speed promise big returns in throughput.

Not surprisingly, it is impossible to achieve productivity gains without changing something. Express testing, our name for the set of techniques we use, is achieved through modifying programmer behavior.

It turns out that most shops have only *one* reason for inefficiency in testing: there are too many manual steps in the test stream that render the power of the computer ineffective. For example, each time a test program calls for a tape mount, a human must notice the event, locate the tape, mount it, perhaps label it, later remove it and return it to storage. Relative to the speed of the machine, even agile operators move slowly. Multiprogramming may improve the machine's productivity, but it merely compounds the turnaround problem by giving the operator more such messages to respond to.

Some shops overcome this operator bottleneck by permitting the programmers to be present when jobs run. Perhaps this is a throwback to earlier times, or a tradition. But programmers, it has been found, move at the same relative speed as operators. Further, they interfere with the operator and with each other, and get little programming done while in the machine room.

Stage one in our conversion to better test techniques involved eliminating the manual steps. Doing this required that the data the program needs must already be *resident* in secondary storage. Admittedly, this goes against the grain of those users who feel that only "important" or "nontransient" data ought to be afforded disk space. A more practical argument might be that an installation cannot afford to use its limited disk resource for test data, but we have found that not more resources but fewer are needed. After more than three years of growth, about 5% of our available disk space is dedicated to programmer test data, down from 12% when the prior method of allocating live packs for testing prevailed. More important, operators are not required to initiate the use of test data, nor are they

even aware of its use; and that has made a vast difference.

Establishing Express testing required the following procedures be implemented more or less simultaneously: (1) compressing test files to manageable size, (2) placing them on-line, and (3) providing immediate access to them.

Like many organizations, ours had to be weaned from the "more is better" attitude about test data. Forced creation of minifiles achieved the necessary selection for us; their data was pulled from larger files both on a logical basis and as the result of random sampling.

File sizes before compression were on the order of 50,000 to 100,000 records, with typical transaction volumes of 2,000 to 5,000 per run. After compression, minifiles ranged from 500 to 2,000 records, using 100 to 200 transactions per test iteration.

Many test runs were reduced from over an hour to less than three minutes. This ratio was even greater for system tests. Our applications systems, such as Savings, Demand Deposit Accounting (DDA), Installment Loan, etc., involve hundreds of programs. Testing one of them might involve testing a stream of 10 to 50 programs and the execution of 10,000 or more lines of COBOL or assembler code.

So long as we performed the logical and random selection properly, the same code was executed, but only a few times each test rather than thousands of times. This accounted for about a 95% reduction in test execution time using minifiles over previous full file tests.

Test output produced all the expected files and reports, but at greatly reduced volume. For example, a DDA report that would normally display the status of 70,000 accounts at 40 branches, produced a report for 500 accounts at 4 branches. Consequently, report output would be reduced from 1,500 pages to 20 pages, but it would still list all the essential control breaks and totals.

Acceptance of the new scheme of things was not swift. Both users and programmers resisted the move to the condensed test files. Users feared that vital data would be lost. Programmers tended to resist reviewing the data and selecting relevant samples. Human

For reasons unrelated to testing, our dynamic environment continued to change.

nature being what it is, they were so busy producing that they had little time for selecting. However, innovators moved to Express testing. Their turnaround time improved, and word spread.

User acceptance came when the early minitests turned up more bugs than former complete runs of systems did. Errors that once appeared in the third box of output now stood out like sore thumbs. Error conditions that had existed for years were now detected. Further, as bugs appeared, the conditions which caused them were added to the minitests and saved on-line for the next test of that job. Hence each release proved out more and more of the system and added to its robustness. Our users now demand minitesting as a prerequisite for systems acceptance.

Putting those test files on-line met resistance too, but a survey found that:

- Many applications tests required multiple tape and disk volumes.
- Time dependencies caused volumes to be reserved when requested for testing.
- Operators couldn't always find the files and thus had to cancel tests.
- As mentioned, mounting files and responding to messages took place at operator speeds instead of cpu speeds.

Migration to on-line test volumes took management scheduling in the early stages. In some cases, especially where live files had been used for tests, a program to perform that migration was required. But in the end of this period, we found that all our test data would fit on a single 3330 Mod I drive—about 5% of our space at the time—once data compression was performed.

How is the space managed? Gross space is mapped out to applications based on relative sizes; some systems take a few tracks and others require several cylinders. Within the gross allocations, project leaders manage the space. Some systems have room for an initial testing condition and up to five iterations that are constantly modified by program cycle testing. Space usage and purging requires some review, for even dormant applications may need some testing. An annual purge of really dead test data has been adequate to fix our 1978 needs at about half a 3330 Mod II drive, still 5% of capacity, three years into the project.

Immediate access to test files was the most difficult facility to establish.

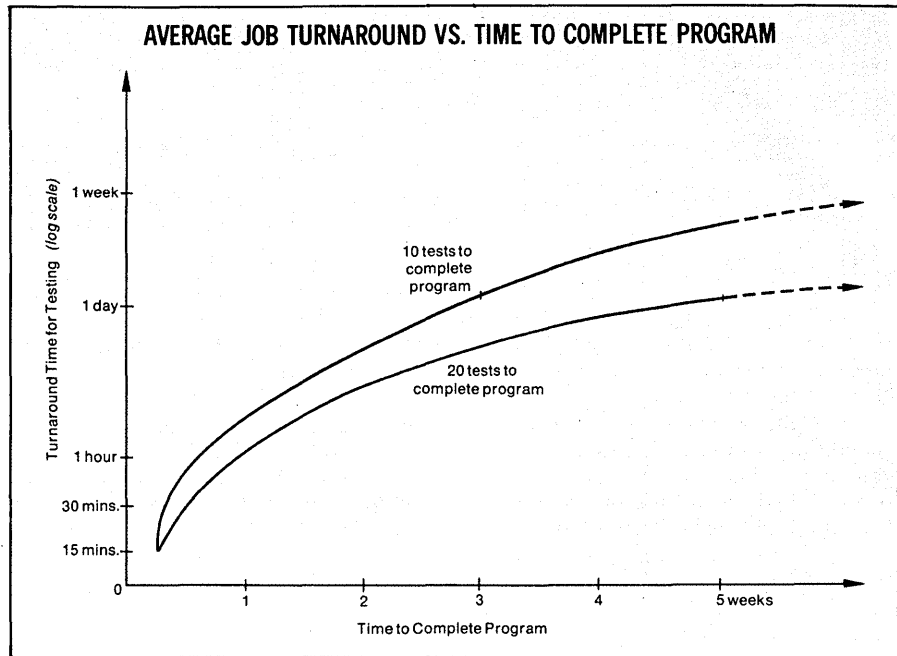

Fig. 1. With very short turnaround time, usually anything under 30 minutes, there's little time to think between runs. With long turnaround times, say one test per day, outside variables like vacation and sick leave have disproportionately great impact on progress. When jobs take more than a day to turnaround, the programmer forgets what he did for the last run.

This implies immediate action on test runs, and resources were at a premium when we began. Initially, no resources were available exclusively for programmer use. Instead of dedicating scarce resources, data center management agreed to handle Express jobs on a priority basis.

Even in the batch operation we began with, Express testing shortened our average test turnaround time from 27 hours (weekends figured in the average) to 16, cut most programmer-present runs, and about doubled the number of tests programmers ran per week. Still not an ideal environment for program development, things were getting better. In fact they were better than the turnaround numbers indicate—since programmers rushed to get one more job submitted before a week-end and these 48-hour turnarounds biased the results.

ON-LINE EXECUTION LOOP

Stage two of the improvement involved going on-line, not an unusual move but not a panacea either. As a byproduct of the DOS to OS conversion, on-line operation was provided through the transition tool, IBM's Conversational Monitor System (CMS). Initially, there were only two crt's (for a staff of 30-35 programmers) for testing. On top of that, there was insufficient storage on the test machine to actually execute the test jobs composed; they had to be shifted under operator control to our other cpu.

Even under this restrictive environment, tests per programmer doubled again and average turnaround decreased to 13 hours as programmers queued test runs through the crt's. By then we primarily used OS, and the CLASS parameter allowed us to schedule the crt-submitted jobs ahead of others.

For reasons unrelated to testing, our dynamic environment continued to change. We converted from VM/370 to native OS. Since CMS runs only under VM/370, it had to go. We replaced it with ROSCOE (a keyboard-initiated remote job entry utility), partly because we were already using ADR's Librarian (a source program maintenance utility), with which ROSCOE works well. (Again, the particular products are not key to the benefits.)

Fortunately, the shift from tapes to disks for test files allowed us to release some tape drives and part of the savings was reinvested in more crt's. Now we have one for about every six programmers, and output per programmer—measured in test turnarounds or in output delivered—has again doubled.

Stage three in our test conversion, we find, is a step many shops oddly do not take. ROSCOE provides a feature (MSGCLASS=0) which routes output back to the programmer's crt. Instead of stopping at the half-step of initiating jobs through the crt and then having the line printer output return later, we eliminated the manual steps in the output and found that this does as much to improve service as eliminating

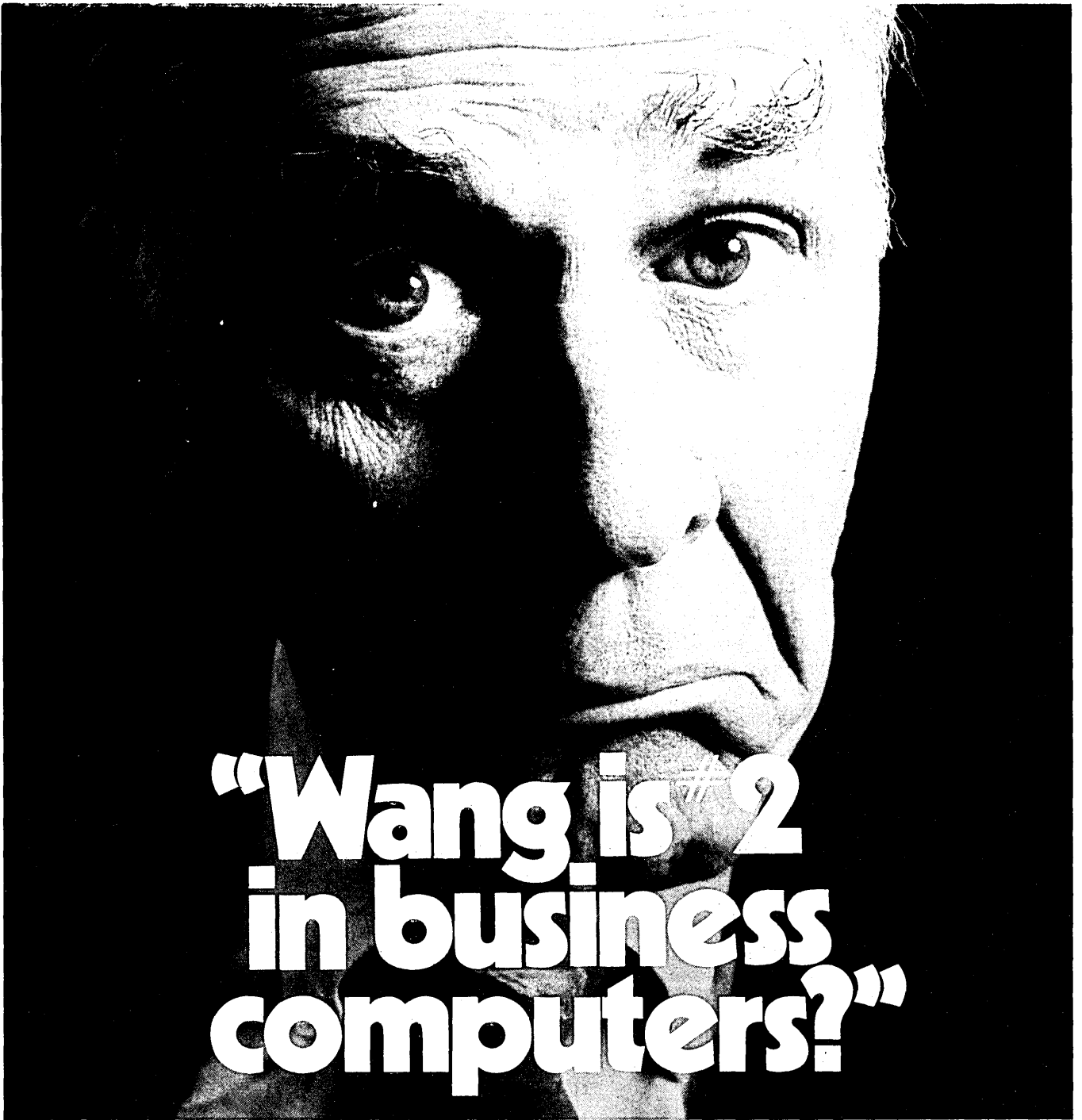

“Wang is 2 in business computers?”

International Data Corp. and Dataquest rank us second only to IBM.*

In small business computers, of course.

No mystery why. It's simply that Wang's hungrier than most. A little more aggressive. More responsive.

And we're not about to stop at small victories.

Whether you're in the market for a desktop computer, or a virtual storage system to complement an IBM mainframe, Wang is a logical choice for several reasons.

Our systems can grow as your needs grow. They're modular. Ex-

pandable. The giant's? Check it out. Every time you outgrow one system you have to chuck it out.

Since controlled growth is critical to your business, shouldn't you be a little more critical of your computer company?

As for value, nobody gives you performance like ours for prices like ours. We've got a technological reputation second to none.

And, we've built a sales and service team bigger than some computer companies ten times our size.

Wang offers a broad line of computers to help you with specific needs. From \$5,000 to \$500,000.

Write Wang Laboratories, Inc., Lowell, MA 01851.
Or call (617) 851-4111.

I want to be more critical about my computer company. Send me information on your line of computers.

Name _____
 Title _____ Phone _____
 Company _____
 Address _____
 City _____ State _____ Zip _____

WANG DP86/D98
Computers and Word Processors.
 Wang Laboratories, Inc., Lowell, MA 01851

*Units installed. IDC's EDP Industry Report, 4/22/77; updated 1/1/78 for EDP/IR Review & Forecast Issue. Dataquest Mini-computer Industry Service Report, 2/3/78.

When the lights go out, so do computers. And when the lights are back, the computers may not remember a thing. They may even suffer permanent brain damage. But if the computer is protected with an Elgar Uninterruptible Power System, it just keeps running, even in a blackout. The Elgar UPS provides up to several hours of back-up protection, plus continuous isolation from line spikes and transients. Models are available in 0.5KVA through 40KVA capacities...one's bound to be just your computer's size. Contact Elgar Corporation fast, while there's still light to dial. In California, call (714) 565-1155. Out of state, call 800-854-2213 toll free.



8225 Mercury Ct.
San Diego, California 92111.

See us at ISA, Booth #160.

**When the lights go out,
an Elgar UPS really shines.**



Elgar also is a leading producer of High Isolation Transformers, AC Line Conditioners, and AC Power Sources.

CIRCLE 176 ON READER CARD

**We don't believe that
three hour turnaround is
everyone's design goal.**

manual intervention in job input had.

Test turnaround fell from the previous 13-hour cycle for on-line initiated jobs to slightly over three hours. Programmers now view output at their convenience and schedule their time around the two remaining variables: cpu time to process runs and programmer time to think.

After experiencing less than one-a-day turnaround, three hour turnaround seems like heaven. We have found that it is adequate, and that we now take testing for granted much as we do main storage in the virtual machine environment. Testing hasn't disappeared by a long shot. We still need detailed, on-line tests, volume tests, simulated and live parallels, and other special cases. But these events are now specially scheduled and occupy only a small fraction of our total testing activity.

We don't believe that three hour turnaround is everyone's design goal. That isn't the point. What we learned is that it takes a combination of things—minitest files, data compression, on-line job composition, on-line job initiation, *and* on-line output—to achieve good turnaround. We were simply in a unique position to see how much each of these contributes individually.

Installations which apply them all will see *correspondingly* sharp drops in their turnaround times. And that's the real point. ❄

LAWRENCE H. COOKE, Jr.

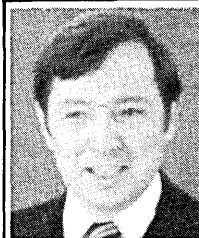

Mr. Cooke is assistant vice president and manager of technical support for Midlantic National Bank, West Orange, N.J. His previous

assignment there was as manager of systems and programming. He began his dp career in 1963 at IBM, directing the development of a compiler for the 7080. From there he went to Computer Applications, Inc. as a technical programmer and project manager. In 1969 he joined the Federal Reserve Bank of New York, where his projects included the design of an international balance of payments data base and the development of the Research Analysis Language (RAL) used by economists in the federal government, at the U.S. Treasury, and at the International Monetary Fund.

EDP books you can't afford to be without

MICROCOMPUTERS/MICROPROCESSORS: Hardware, Software and Applications

by J.L. Hilburn & P. N. Julich
771/499 Pub. Pr., \$19.50 Club Pr., \$15.60

CHARGING FOR COMPUTER SERVICES: Principles and Guidelines

by D. Bernard, J. C. Emery, R. L. Nolan & R. H. Scott
771/863 Pub. Pr., \$10.00 Club Pr., \$8.50

DATA PROCESSING CONTRACTS

by D. H. Brandon & S. Segelstein
770/972 Pub. Pr., \$34.50 Club Pr., \$25.50

MINICOMPUTER SYSTEMS Organization and Programming

by R. H. Eckhouse, Jr.
768/641 Pub. Pr., \$18.95 Club Pr., \$13.95

COMPUTER ARCHITECTURE AND ORGANIZATION

by J. Hayes
273/634 Pub. Pr., \$21.50 Club Pr., \$16.50

PRINCIPLES OF DATA-BASE MANAGEMENT

by J. Martin
769/907 Pub. Pr., \$19.95 Club Pr., \$16.25

COMPUTER STORAGE SYSTEMS AND TECHNOLOGY

by R. E. Matick
772/223 Pub. Pr., \$29.95 Club Pr., \$23.95

TOP-DOWN STRUCTURED PROGRAMMING TECHNIQUES

by C. L. McGowan & J. R. Kelly
769/052 Pub. Pr., \$15.95 Club Pr., \$13.50

COMPUTER DATA STRUCTURES

by J. L. Pfaltz
497/435 Pub. Pr., \$19.50 Club Pr., \$14.60

WRITTEN COMMUNICATION FOR DATA PROCESSING

by R. S. Smith
769/77X Pub. Pr., \$12.95 Club Pr., \$9.75

STANDARDIZED DEVELOPMENT OF COMPUTER SOFTWARE

by R. C. Tausworthe
784/40X Pub. Pr., \$19.95 Club Pr., \$15.95

HIGH LEVEL COBOL PROGRAMMING

by G. M. Weinberg, S. E. Wright, R. Kaufman & M. Goetz
768/595 Pub. Pr., \$17.95 Club Pr., \$14.95

ALGORITHMS + DATA STRUCTURES = PROGRAMS

by N. Wirth
769/664 Pub. Pr., \$19.00 Club Pr., \$13.75

CURRENT TRENDS IN PROGRAMMING METHODOLOGY Volume I Software Specification and Design

by R. T. Yeh
783/829 Pub. Pr., \$19.95 Club Pr., \$15.50

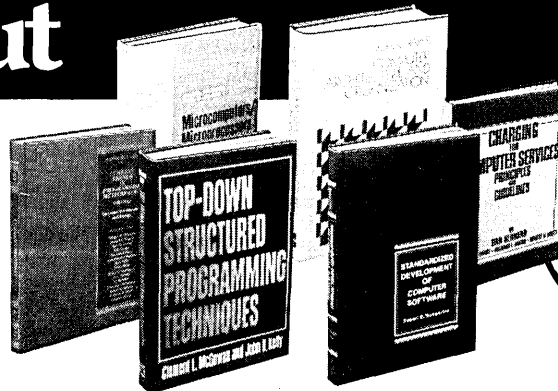

any one
of these great
professional books
for only **\$1.89**
values up to
\$34.50

Introductory offer to new members of the Computer Professionals' Book Club

Special \$1.89 bonus book comes to you with your first club selection

This professional club is designed to meet your day-to-day on-the-job needs by providing practical books in your field on a regular basis at below publisher prices. If you're missing out on important technical literature—if today's high cost of reading curbs the growth of your library—here's the solution to your problem.

The *Computer Professionals' Book Club* was organized for you, to provide an economical reading program that cannot fail to be of value. Administered by the McGraw-Hill Book Company, all books are chosen by qualified editors and consultants. Their understanding of the standards and values of the literature in your field guarantees the appropriateness of the selections.

How the Club operates: Every month you receive free of charge *The Computer Professionals' Book Club Bulletin*. This announces and describes the Club's featured book of the month as well as alternate selections available at special members' prices. If you want to examine the Club's feature of the month, you do nothing. If you prefer one of the alternate selections—or if you want no book at all—you notify the club by returning the card enclosed with each *Bulletin*.

As a Club Member, you agree only to the purchase of four books (including your first selection) over a two-year period. Considering the many books published annually, there will surely be at least four you would want to own anyway. By joining the club, you save both money and the trouble of searching for the best books.

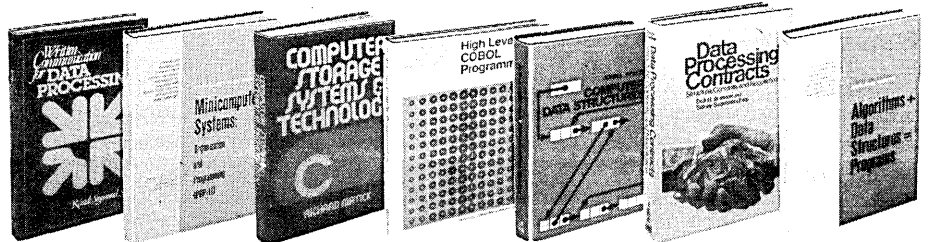

VALUES UP TO \$34.50 WITH MAJOR DISCOUNTS ON ALL OTHER CLUB SELECTIONS. Your bonus books come with the first selection, and you may choose both of them from the books described in this special introductory offer.

EXTRA SAVINGS: Remit in full with your order, plus any local and state tax, and McGraw-Hill will pay all regular postage and handling charges.

NO RISK GUARANTEE:

If not completely satisfied return selections for full refund and membership cancellation.

MAIL THIS COUPON TODAY

COMPUTER PROFESSIONALS/Book Club P.O. Box 582 Princeton Road, Hightstown, New Jersey 08520

Please enroll me as a member and send me the two books indicated. I am to receive the bonus book at the introductory price of \$1.89 plus my first selection, plus tax, postage, and handling. If not completely satisfied, I may return the books within 10 days and request that my membership be cancelled. If I keep the books, I agree to take a minimum of three additional books during the next two years at special Club prices (guaranteed 15% discount, often more). I will receive the Club Bulletin 13 times a year. If I want to examine the featured selection, I need take no action. It will be shipped automatically. If, however, I want an alternate selection—or no book at all—I simply notify the Club by returning the convenient card always enclosed. I will always have a minimum of 10 days in which to return the card and you will credit my account fully, including postage, if this is not the case. Membership in the club is continuous but cancellable by me at any time after the four-book purchase requirement has been filled. This order subject to acceptance by McGraw-Hill. Orders from outside the continental U.S. must be prepaid. Company, business, or institutional tax exemption status is not applicable to pur-

chases made through individual Club memberships. All prices subject to change without notice. Offer good for new members only. A shipping and handling charge is added to all shipments. Members are billed when books arrive.

Write Code # of \$1.89 bonus book selection here

Write code # of first selection here

NAME _____

ADDRESS _____

CITY _____

STATE _____ ZIP _____

P39307

There is still an absolute and desperate need for user involvement with a central staff. It's called "standards."

"DISTRIBUTED" DOESN'T MEAN "RANDOM"

by Ken Falor

Because minicomputers have miniprices, and often implement applications quickly and painlessly, little attention is given to their widespread implementation in a company or organization until after the fact. Then certain difficult intersystem problems can arise that could have been easily handled had planning entered the process at an early stage.

For example, the whole process of system requirements analysis and vendor evaluation may be repeated countless times, with little information passed on for the next evaluation. A myriad of operating systems, programming languages, file and data structures may result in a corporate Babel of incompatibilities.

This is the general state of affairs today. However, many organizations recognize that the use of minis will grow, and that the sooner these problems are dealt with the better, not only for the corporate interest but for the benefit of individual users as well.

There is little to be gained by attempting to reestablish strong central control and outlaw minicomputers. Minicomputers are a technological advance with many real and honest advantages in terms of price/performance and in ease of implementation and use. There is no going back without making the organization suffer.

Besides, one manager's anarchy may be another's democracy, rightfully delegated. The increasing tendency of business and governmental organizations to establish profit centers and similar independently accountable enti-

ties also results in more autonomy for managers—especially when it comes to getting local computer power for a price lower than possible with the traditional centralized approach.

However, there is still an absolute and desperate need for user involvement with a central staff. This need is for effective standards.

As central staffs have worked through the process of standardizing the data environment, they have found that this is a way to have their cake and eat it too. By establishing effective standards and providing consultation for minicomputer implementation, they are able to report to top management that more information problems are being solved faster, and solved within a coherent framework which benefits the organization's long term interests.

At the same time, they are able to relieve themselves of the actual burdens of design, implementation, and maintenance. Information systems managers find they spend less time as big-machine tenders and more time as managers. In short, they move from being systems managers to being information managers, and become more involved in the end concerns of their top management.

HARDWARE AND SOFTWARE

One of the first and most obvious opportunities for standardization is with the basic hardware and software. The goals are transferability, compatibility, and backup, as well as minimization of time and money wasted on repeated systems evaluation.

Most companies establish some standards regarding vendors and operating systems. With vendors, this will vary from recommending a single supplier to allowing a choice from a long list of suppliers developed by eliminating those which are completely unsuited for the principal application area (such as those which offer no COBOL), or lack required geographical support capability, or with problems of similar scope.

Some companies will even establish a standard list of specific equipment models and operating systems. Two considerations in doing this are the systems' continued long term growth, and migration possibilities. It is vital that a company acquire systems which will be enhanced, improved, and supported by the vendors for many years to come, and that when new systems are developed, migration opportunities are also provided by the vendor.

Standard peripheral devices may also be specified. Of particular importance are the disks. Not only can especially reliable models be recommended, but restricting the range of models makes it possible to move a disk pack from one machine to another in an emergency.

One frequently bypassed area of standardization is programming languages. The advent of more high level languages on minicomputers makes it possible to establish language standards in the same way as for large computers. FORTRAN for scientific and engineering work and COBOL or BASIC for all commercial and transaction processing work are common stand-



/malt

The central point for justifying standardization is often data communications.

ards. Exceptions are allowed for time-critical work (such as sensor-based real time applications or data communications) where assembly language is required, and for transaction processing forms design languages, where implementation advantages are great but no industry standards yet exist.

It is also possible to establish "safe" subsets of FORTRAN and COBOL that work on virtually all minicomputers. The advantage here is not just program transferability, but *programmer* transferability. In other words, a centralized and effective training program can be established, central consulting services can be provided, widely useful applications and utilities routines can be distributed throughout the company or organization, and a programmer can work on another person's programs with fewer learning problems.

Note that standardization of hardware and software can expand career opportunities within an organization. A programmer can more readily move horizontally or geographically, and opportunities exist to move upwards to larger or more critical facilities.

Obviously, all this also has an important impact on maintenance and service considerations. Internal skills can be built up much more rapidly for only one or two basic types of hardware and operating systems. Having many installations of the same vendor's equipment can frequently justify increased support from that vendor, even for remote locations. And while it is unwise to make a single operating system or language do the work of both sensor-based and business processing, it is wise to avoid the almost random selection that sometimes takes place. Standardization here means fewer problems keeping everyone current on the latest releases of these systems, and improved familiarity with their idiosyncracies.

Another benefit of central standardization is the wide applicability of purchased application and utility software packages. Few facilities would ever standardize for this reason alone, but many would enjoy such side benefits once standardization has been established for other reasons.

Finally, the likelihood of quantity discounts from minicomputer manufacturers cannot be overlooked. With the growth in the use of minis that many large organizations are experiencing, we can quickly find ourselves talking in terms of a \$ million in savings.

STANDARDIZING DATA The most urgent aspect of *design* standardization deals with data fields and files. While it seems too much to hope for any ready compatibility of file structures between minicomputers of different manufacturers, it is perfectly reasonable to ensure compatibility between models made by the same manufacturer.

File compatibility really lies on two levels. One is the underlying structure which the programmer does not see, at least not until he attempts to use the file on another piece of equipment. This concerns the on-disk structure, tape formatting, and data type characteristics.

Usually the only solution to this is to require that a universal tape format is available, so that tapes can be generated and read on any machine. Most minicomputer manufacturers offer one.

The second level is that under the control of the programmer. This again breaks down into two parts, the most important of which is the data field specification. Most companies looking into this problem take a kind of manual data base approach. That is, they issue an extensive standard list of fields, specifying field size, type (packed vs. zoned decimal), and implied decimal place. It is also advantageous to establish standard field names or naming conventions to further improve the ability of programmers who are unfamiliar with a particular program to change or maintain it.

The other part of the file compatibility problem is the question of standard record types. This question is usually relatively straightforward, and results in agreements regarding fixed vs. variable length records and where to put the record identifier in multiple record files. A more difficult question is how to deal with relative or hash-calculated access techniques. This can be resolved by providing some standard and widely-accepted algorithms or fixed routines. If chaining is involved, the pointer fields may be specified as following the record type field, and logical vs. physical pointers may be favored.

Probably equally important to the standardization of fields and files is the need to find some mechanism that simply informs the central staff of what kind of data is being stored and maintained on the many minicomputers in all parts of the organization. Using this mechanism, the central operation can locate the data that top management needs.

This mechanism may also provide an opportunity to review the security requirements of data. In one respect, the security hazard is greater with minicomputers, but in another, it is smaller. If an outsider (or self-motivated insider) penetrates the system, more complete access to programs and data is possible without detection, but a far more limited set is available compared to the successful penetration of a central site.

The only solution for the security problem is the establishment of some security standards (such as separation of personnel, customer name, or account name from the rest of the file) for specified types of data, possibly encryption of very sensitive data, and periodic audits of the type that have been standard for many years throughout the business world.

DATA COMMUNICATIONS

The most urgent area of standardization, and often the central point upon which the justification of all standardization may depend, is intersystem data communication.

One reason that generalized data communications implementations often turn out to be much more difficult than they appear is that they must not only handle lines and manage protocols, but must also repair all the incompatibilities between operating systems, program calls and linkages, file and data types. In a multivendor environment, these incompatibilities may be correspondingly multiplied.

The standards selected must be amenable to implementation on all the computers which communicate with one another. This may be done through adoption of a generalized or universal protocol, or a customized subset, or through emulating a de facto standard such as the ones used for IBM 2780 or 3270 terminals.

The data communications task can range in complexity from the providing of a universal tape or floppy disk format for physically carrying or mailing data from one system to another, to a simple two-node line transfer mechanism based on some widely used protocol, to managing a multinode network employing specialized front-end processors, leased lines, satellites, and a full-time staff of communications specialists.

The particular standardization of the data communications task selected will vary depending on the volume of communications, time sensitivity of data, the direction of transfer (mini to mini vs. host to mini), the number of

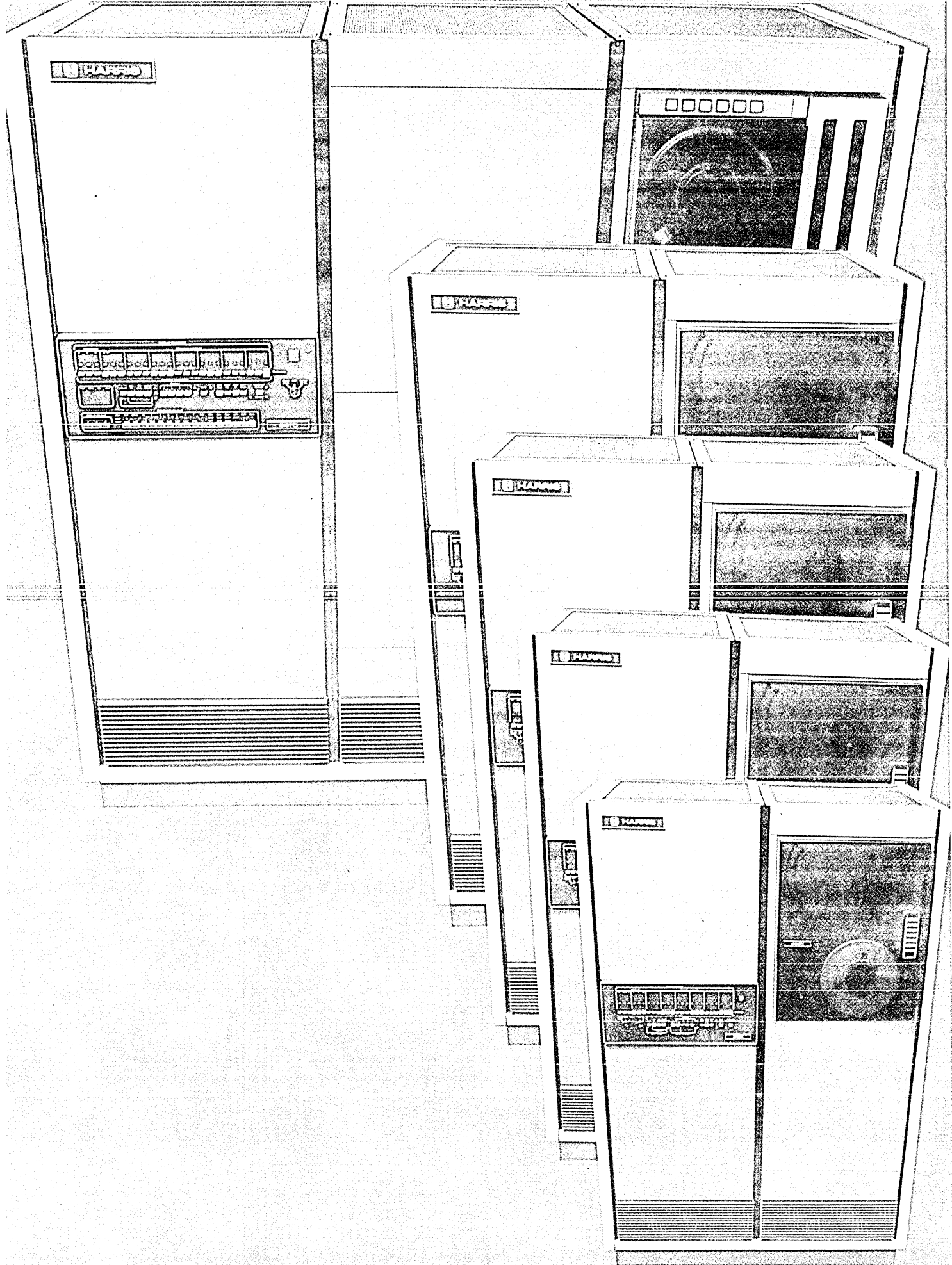

The new Harris S123 and S570. You get the capability you need at capacities you can afford.

Harris introduces the S123 and the S570.

These two new computer systems expand the range of VULCAN, Harris's applications proven Virtual Memory Operating System, offering new products for both smaller and larger users.

Both the S123 and the S570 offer mainframe capability.

Both operate with COBOL, FORTRAN, APL, BASIC V, RPG II, FORGO, SNOBOL... and TOTAL, concurrently.

Both are versatile. From dedicated applications to broad general purpose use. Conventional batch processing to demanding real-time modes of operation. Single site to deployed computer facilities. Multiple user concurrence to concurrent multiple uses.

The difference is capacity.

The S123 is the entry level system. It has the capacity to support up to eight terminal users. 144K bytes of real memory, 768K bytes of virtual memory.

The S570 can support up to 64 terminal users. It has up to 3M bytes of real memory. 12M bytes of virtual memory.

All Harris computer systems, from the S123 through the S570, are VULCAN based. All reflect the dependability, predictability and reliability that only a highly efficient, fully matured operating system can deliver. VULCAN based also means that you can grow with Harris without a costly change in applications software and files.

If your need is distributed processing, time sharing, data base management, or any type of concurrent multi-use applications, benchmark Harris.

Harris Computer Systems, 1200 Gateway Drive, Fort Lauderdale, Florida 33309. Telephone: (305) 974-1700. Europe: Harris Systems, Ltd., 145 Farnham Road, Slough, SL1 4XD, England.

All at once, it's Harris.

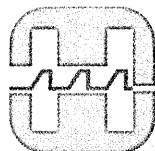

HARRIS

COMMUNICATIONS AND
INFORMATION HANDLING

Watch this Kodak laser printer print a 150-page report.

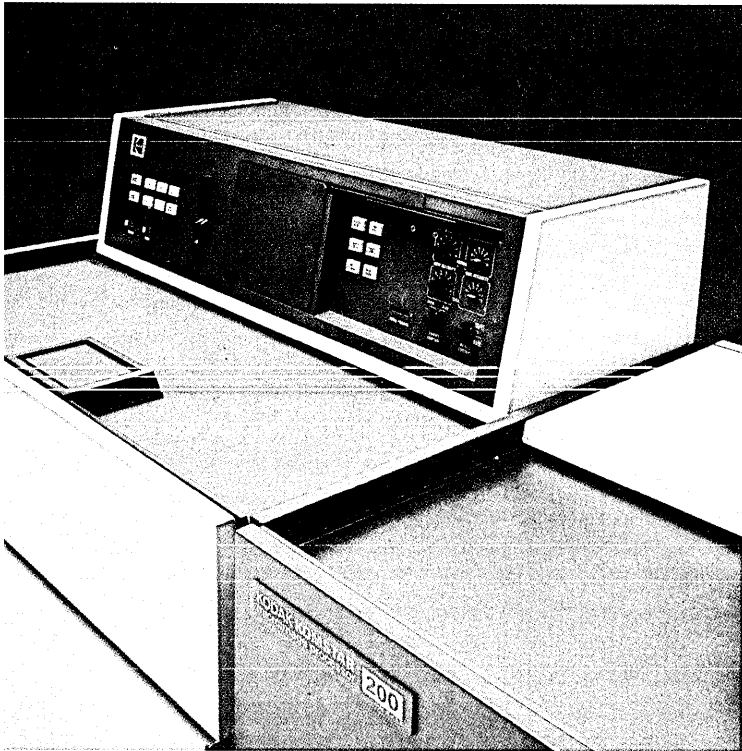

The Kodak laser printer prints at the rate of more than 2½ computer pages per second.

So it can zap out a 150-page report in a shade under one minute. Or a 1000-page report in about 6 minutes.

Because it prints on microfilm—not paper—the Kodak printer condenses up to 270 bulky computer pages on a single 105 x 148-mm fiche. And it does it in under 2 minutes.

That means a Kodak printer can print a 1000-page report at a reduction ratio of 48:1 on just 4 microfiche. And each fiche is produced, titled, and indexed, ready for fast retrieval.

How does paper stack up against fiche? Using current prices,* 1000 pages of computer paper would cost \$3.50, while 4 fiche would cost just 54¢. So compared with paper, not only is printing on film demonstrably faster, it's also thousands of dollars a month cheaper.

Why not call your Kodak representative today for a demonstration of the Kodak

Want to see that again?

Komstar 100, 200, or 300 microimage processor. But hurry. Every day you wait costs you money.

Eastman Kodak Company,
Business Systems Markets Division,
Dept. DP-8671, Rochester, N.Y. 14650.

SEE US AT INFO '78, BOOTH #286



**Kodak Komstar microimage processors.
The printers that print without paper.**

*Prices vary with geographic location and grade of paper purchased.

As though controlled by Pavlovian conditioning, computer people religiously accepted the commandment against ever writing machine-dependent code again.

THIRD GENERATION MYOPIA

by R. Edward Mitchell, Jr.

The origin and history of a disease that has reached epidemic proportions among the ranks of computer professionals, threatening their vision and judgment!

If you look around very carefully you may notice a curious discontinuity in the thought processes of many of your acquaintances in the system design and programming profession. This particular aberration manifests itself in a phenomenal inability to correlate and associate the data processing capabilities of a given computer with a given applica-

tion. Instead, the afflicted persons have only the lesser ability to correlate the capabilities of a given computer *programmed in a certain language* with a given application.

Having unearthed no previous name for the affliction, this writer has chosen the term *Third Generation Myopia*, or simply TGM, for the purposes of this discussion. The origins and causes of TGM lie camouflaged by time somewhere back in the formative years of the computer programming profession.

BACK IN HISTORY

Two decades ago computing machines were still in their "first generation." Most of the machines of that era were less powerful

than many of our pocket calculators today. However, even though computers of that time were slow by present standards, the first generation machines gave us all the tools we needed for learning and defining a new science and profession known as *computer programming*.

Then in the late '50s, after several rumor-laden years of waiting, IBM rang up the curtain on what we now call the second generation of computers. The new machines were transistorized, more compact, and faster. Storage space was comparatively vast, composed of tiny ferrite doughnuts. Peripheral devices were cleverly engineered with fewer moving parts that, when they did move, moved many times faster than before.

The instruction sets were some of

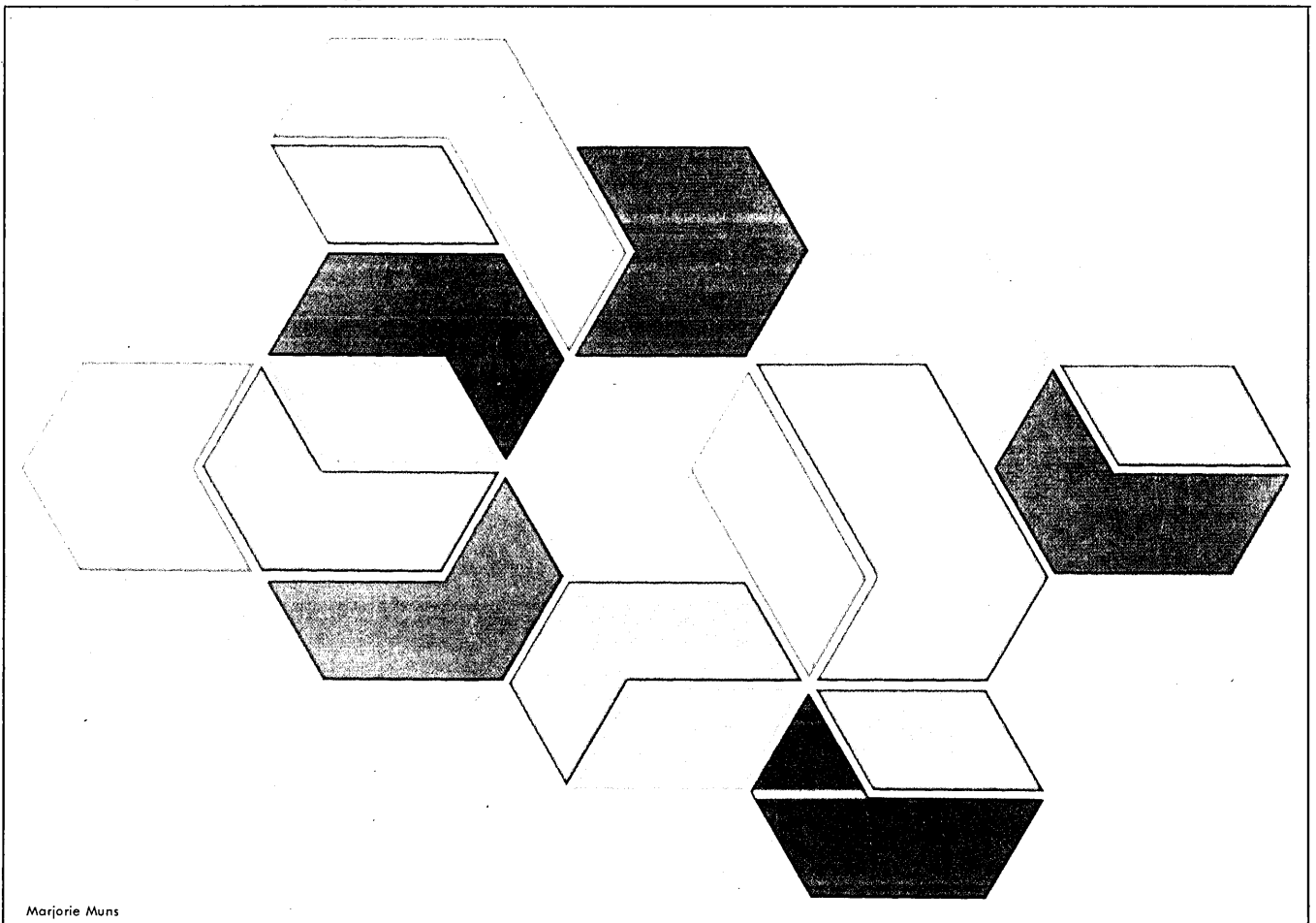

Marjorie Muns

Any way you cut it, our Remote Computing Services offer you more

An ever-expanding network.

- Our nationwide data communications network keeps growing, providing even greater flexibility and economy-of-use:
- Toll-free dial-up access from all 50 states to our major Host Data Center.
 - Transmission speeds from 110 baud to 50KB.
 - You can choose **IN-WATS, packet switching** or where applicable and cost-efficient, **dedicated dial or dedicated lines.**

Unique application packages and tools.

- Our RCS (Remote Computing Services) offers you over 60 application packages and tools:
- Our unique MAS-80 family of manufacturing application systems (Inventory Control, Production Control, Engineering Control).
 - A full range of languages: **APL under TSO; BASIC; FORTRAN; COBOL; PL/I.**
 - Extensive interactive text editing and data management services: **WYLBUR; ATMS II; EASYTRIEVE; TSO; and others.**

MARTIN MARIETTA DATA SYSTEMS
 300 East Joppa Road, Baltimore, Maryland 21204
 ATTN: Dick Nemerson

- Please send me your free RCS brochure.
- Please have someone contact me.

NAME _____

TITLE _____

COMPANY _____

Address _____

CITY _____

STATE _____

ZIP _____

PHONE _____

State-of-the-art.

- Our RCS offers virtually limitless capacity:
- Multiple Host Data Centers with: twin IBM 3033s; a 168; twin 158s, and a CYBER 172; plus 135 billion characters of on-line storage.
 - State-of-the-art software and DBMS services: IMS; DL/1; SYSTEM 2000; IDMS; CICS; MVS/JES2; and others.
 - Use of virtually any interactive terminal or programmable terminal, minicomputer or mainframe supplied with HASP/JES software.

Security & reliability.

- Comprehensive protection of your resources and continuity of service is assured with:
- Multiple and compatible mainframes at our major Host Data Center.
 - Our Uninterruptable Power Supply (UPS) system that protects against service disruptions associated with black-outs and brown-outs.
 - RACF (Resource Access Control Facility) software, providing privacy plus control of data access.

For instant information, call Dick Nemerson at MMDS headquarters (301) 321-5744.

Martin Marietta Data Systems

We Build & Run Systems

300 East Joppa Road, Baltimore, Maryland 21204

CIRCLE 120 ON READER CARD

Good data processing management ensures that good quality code is produced; good quality code is practically immortal.

the most interesting and most significant features of the new breed. Earlier programmers could only LOAD and STORE the Accumulator, with most other operations being merely variations on the same theme. Now there were variable-length operands, memory-to-memory operations, edit commands, and many other new capabilities that expanded programming horizons.

As the second generation developed, the analysts, managers, directors of computing, and assorted experts collectively arrived at a fateful realization. As if their minds were webbed together by direct mind-link they universally surveyed the scene of clattering printers, spinning tape drives, and thousands of programmers furiously coding Autocoder in thousands of cubicles, and said to themselves, "This is it!" We have arrived and this is *The Way*.

The rest of the story is well known. This collective decision and the resultant commitments made by data processors everywhere set the stage for a huge, multi-\$billion Horror Show that was to unfold in yet the next generation of computing machines. Because, as the wraps came off the third generation systems, it was immediately apparent that something had somehow gone awry. The new machines were good, very good. And they were very, very different. So different and so much better, in fact, that it took a while for data processors to see the trap into which they had fallen.

THIRD GENERATION HORRORS

All of the programming and development that went into second generation hardware was horribly and unalterably wrong. Not only wrong but so far out, so alien from the right way (as manifested by third generation hardware) that much of the old software could not even be converted to the new machines.

Corporate officers, who had become comfortable in the knowledge that computer programs, once written, continued to work forever, now saw tangible assets disappear like wisps of smoke. Heads rolled, reputations were tarnished, careers were ruined, and the boards of corporations asked penetrating questions of their computer people for which there were no satisfactory answers.

"You call yourselves professionals?" echoed across countless conference rooms. "How could you have been so stupid?"

The overreaction was predictable

and understandable. As though controlled by Pavlovian conditioning, computer people profoundly and religiously accepted the commandment that thou shall never write machine-dependent code again. This new law became reinforced in the minds of data processors, business managers, government contract officers, and through time has even pervaded the highest levels of commerce and government. As a natural consequence, many executive officers and presiding bodies have chosen to overstep their competence and knowledge of the subject by decreeing that only high level compiler languages may be used henceforth on the computers under their control. Suggestions that more efficient code might be necessary in certain cases are regarded as heresy.

Many large companies now have corporate policies that forbid any programming languages other than certain specified high level compiler languages. Many agencies of the U.S. government specifically forbid the use of assembler level programming.

Partly as the result of this, there are tens of thousands of computer programs alive and running in corporate and government computer centers today using many, many times as much computing resources as is necessary to perform their intended functions.

As a brief case in point, an expert programming consultant was asked to solve a particularly elusive bug in a large text processing program written in COBOL. After some examination it appeared that certain of the COBOL monitor routines were occasionally running amok causing the program to fail. Since a fix for the monitor routines might take months to obtain from the vendor, the programmer recommended recoding the program in ALC.

The recoding and testing was completed in a few days by using the original COBOL as detailed programming specifications. Not only did the ALC program work flawlessly, but in the process of transliterating the code into ALC, the programmer discovered a subtle error in the original COBOL. That error turned out to be the source of the alleged failure in the monitor routines.

The client was naturally happy to have the software in service. However, the most significant by-product of this exercise turned out to be an astounding drop in the processing cost from \$200 to about \$30 for an average sized file using the new ALC program. Since the program periodically received very heavy usage, this change had a bene-

ficial effect on the overall project budget.

As another example, a large electric utility company with a heavy commitment in data processing has instituted a policy endorsed by its board of directors that only COBOL and FORTRAN may be used for programming within their computer installation. This policy was probably fostered by a very expensive and bitter conversion experience from second generation hardware. To write a program in assembler, the analyst or programmer must secure specific, hard to get permission in each individual case. Exemptions are so difficult to obtain that almost no in-house programmers ever try. Moreover, only COBOL and FORTRAN programmers are hired as permanent staff.

In this company's computer operations, most applications are, in fact, best suited to compiler languages. However, a number of large, unwieldy and very costly to run systems have been written with sinuous streams of obfuscated high level code that could have been written as fast, lean modules at the assembler level. It is those systems, some of which see heavy usage during the prime shift, that are chiefly responsible for this company's inordinately heavy demands on an already overloaded system.

From a hardware configuration point of view, their computer has plenty of horsepower to handle the data processing load at hand. But saddled with years of accumulated compiler programs, many of which are performing functions much better suited to a low level language, the system is loaded past its limit for satisfactory batch turnaround and terminal response time. Management, of course, had the normal and expected reaction: next year's dp budget has been substantially increased and a larger computer is now on order.

DEBUNKING THE MYTHS

One of the strongest fears voiced by sufferers of TGM is the same fear that started TGM in the first place: that someday the machine's instruction set will no longer be supported! And as an attempt to avoid another Horror Show, they voluntarily elect to saddle themselves, their companies, and their successors with years of accumulation of compiler code.

For IBM 360/370 users, at least, this is probably an unreasonable fear. Already there are many hardware manufacturers offering competitive

Building a

The Michigan Mutual Experience.

“With the Datapoint systems our computer network is a real vehicle for company growth. Our field offices have intelligent data entry and processing power for local work needs. We’ve eliminated the problems of uncertain mail service and input error in data handling, and we’ve speeded customer service in issuing new policies and responding to claims.”

Karl Dowd, Vice President/Data Processing
Michigan Mutual Insurance Co.
Detroit, Michigan



00130 IOM *19 1304 131

00000 JOB *4:A

00321 A&Y *26 1402 140
1467 1470 147

00213 KEYUT *23 1410 141

02336 KPAUSX *135 1748 175

00641 EFFMO *44 279 2E
2791

00653 EFFYH *46 288 28

01562 ERNFLD *98 1574 155

01630 EXPIRE *105 996 99

03632 FILEDATE *213 1962 245

01571 FIRST *100

01574 FIRST1 *101

04467 FLAG *266 2982 300
3131 3147 315

03271 FORM1A *178 1072 107
1162 1166 117

02532 FSTENT *134 1733 174

03671 INDKEY *220 1950 196
2463 2465 246
2512 2513 251
2586 2587 258
2700 2701 270
2755 2756 275

00130 IOM *19 1304 131

00000 JOB *4:A

00321 A&Y *26 1402 140
1467 1470 147

00213 KEYUT *23 1410 141

02336 KPAUSX *135 1748 175

Detroit-based Michigan Mutual Insurance Co. is a major supplier of multiple line casualty and property insurance services. The 66-year old company is perhaps best known for its pioneering efforts in worker's compensation insurance but for many years it has also written other casualty and property insurance lines. The company has about 250,000 insurance policies in force. In 1977 the company generated sales of over \$180 million working with a network of branch and regional sales offices that extend to nearly 50 cities in 13 states.

Linking these scattered offices together with an IBM 360/65 unit in the Detroit headquarters of Michigan Mutual is an advanced computer/communications network based upon Datapoint DATASHARE systems located in home and regional field offices. These DATA-SHARE systems provide both communications linkage to the central mainframe in Detroit and

computer power for satellite Datapoint 3600 workstations which are located in regional and field offices.

Currently the Michigan Mutual network utilizes six DATASHARE systems based on Datapoint 5500 processors located in as many cities. Each of these processors service in turn up to eight Datapoint 3600 workstations. These workstations are located in field office cities and connected via telephone to the regional office, or located in the regional office near the processor. At least one terminal in each office is equipped with its own terminal printer.

"That's a big plus with the Datapoint units," said Mr. Dowd. "The 3600 workstations in our branch offices needn't depend on a centralized batch printer, which gives us a lot more flexibility." Each 5500 processor also utilizes twin 20 million character disk drive units which allow important policy information to be stored locally. "We will return about 75% of our master file to be stored on local disk storage units," said Mr. Dowd.

"By returning an appropriate portion of our master file data to the local host storage units," said Dowd, "There's no need to resort to central computer storage for over 90% of field office-generated inquiries and file look-ups. Hence, without incurring long distance communications costs, the field offices can give a lot faster customer service. This has proven to be a big plus especially in working with independent agents who are not used to that kind of convenience.

Other benefits

"The Datapoint units enable us to make just one-time entry of data in our field offices for a multitude of subsequent applications," said Mr. Dowd. "In addition, the on-site computer power represented by the Datapoint processors enables us to off-load work from our central IBM unit and lets our field offices handle locally much of our claims adjustment and policy issuance activities without involving the home office. We process about 700,000 policy transactions and handle about 130,000 claims annually, which

gives you some idea of the work load. At night when telephone rates are lowest the home office 5500's automatically 'poll' the processors in the field for summary information. This arrangement alone enables us to realize substantial savings in data communications costs and allows us to avoid almost all the uncertainty and time lags we experienced in mailing source documents to the home office."

Making the most of the mainframe

Dowd is especially proud of the cost/effectiveness of the IBM 360/65 system, an older system although recently installed at Michigan Mutual. "It's an old-line 'Fleetwood' system," noted Dowd, "with more than ample power for our needs. With our dispersed processing network and the ability of the Datapoint processors to handle growing workloads in our field office, we should be able to handle our volume for the foreseeable future in a very cost/effective manner. For some of our field offices where workload warrants, we may install low-cost units such as the Datapoint 1500 which can participate directly in our overall network and provide much greater on-site processing power. We have also installed in our home office a full Datapoint ARC™ system with DCIO (Direct Channel Interface Option) which adds both more horsepower and more convenience to our network."

Michigan Mutual has made dispersed processing pay off big, and so can your company. For information on how to create a cost/effective computer network based on advanced Datapoint processor systems and peripherals, contact the nearest Datapoint sales office or write or call Datapoint Corporation, 9725 Datapoint Drive, San Antonio, Texas 78284, (512) 699-7059.

DATAPPOINT CORPORATION

The leader in dispersed data processing™

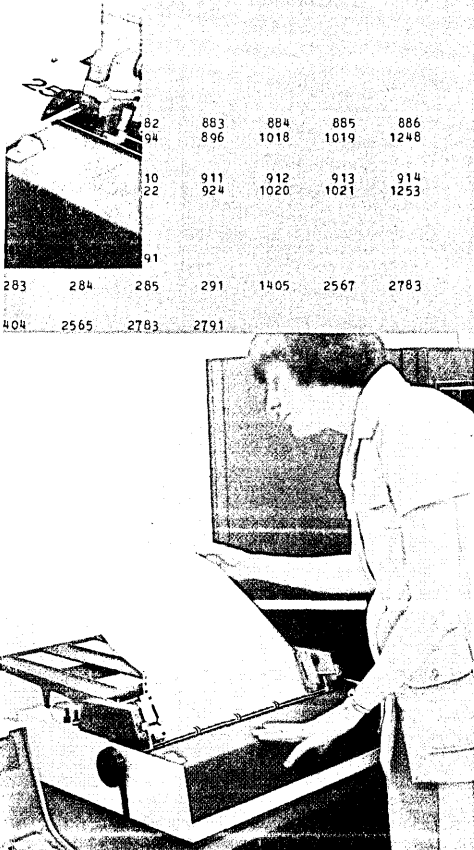



THE THRIFTY LP2 PRINTER. THE OPTIONS COME STANDARD.

Data General's new 180 cps, logic-seeking bidirectional printer. It's more competitive so it makes you more competitive. Packed with a lot of standard features that cost you extra on other printers. Like forms control, vertical and horizontal tabbing, variable character sizes, a 7 x 9 matrix, plotting under software control and international fonts. Now, no matter what goes into your computer system, it can come out economically on a Data General Dasher LP2. Call for additional information. Or send for our brochure.

 **Data General**
We make computers that make sense.

LP2

Name	Title	Company	Tel. No.
Address	City	State	Zip

DM978

Data General Corporation, Westboro, MA 01581, (617) 366-8911. Data General (Canada) Ltd., Ontario. Data General Europe, 61 rue de Courcelles, Paris, France, 866.51.78. Data General Australia, (03) 80-0633. Data General Ltda., Sao Paulo, Brazil, 543-0138. Data General Middle East, Athens, Greece, 952-0557. © Data General Corporation, 1978.

Some applications call for programming a language, others for programming a computer.

cpu's to process the 360/370 instruction set. Were IBM to completely abandon that instruction set in a new series of processors (albeit unthinkable in terms of good business sense), many other suppliers stand ready to supply the already established market. In any event, the machinery and software to process the 360/370 instruction set will be available at least into the next century. Admittedly, the instruction sets of other manufacturers have a much less certain future.

Another therapeutic exercise which might help alleviate some of the paranoia produced by TGM is recognition of the quality and permanence associated with the 360/370 instruction set. Upon questioning a number of competent, broadly experienced programmers, I have found that most agree that the 360/370 instruction set is the best all-around *data processing* repertoire of any commercially available machine.

Another myth has to do with cost. The cost of developing a program with the different languages depends largely on the application and, naturally, on the skills of the programmer(s). However, given an approximately equal skill level among the programmers of COBOL, FORTRAN and ALC in an installation, some valid generalizations and cost comparisons can be made. For example, a heavy mathematical application with many long formulas and math functions can be developed faster and cheaper in FORTRAN; while the same program in ALC might run a little faster, the savings would probably be minimal and would never pay for the added development costs.

A small, special purpose module for generating reports might be most easily developed in COBOL and could present a number of lengthy chores in ALC or FORTRAN. Again, any savings in execution costs might as well be ignored.

A program with many data transformations, bit and byte manipulations, character scans and string searches and so forth is generally much simpler to do in ALC whereas the same problem becomes circuitous in the high level languages.

Then there's the conversion myth. Well written and well documented assembler code is fully translatable, sometimes more so than compiler code. Most of the rigors of conversion from second to third generation hardware were caused by poor programming standards and practices. During that period, many programmers delib-

erately wrote complicated, exotic code, possibly as a manifestation of their competence and intimacy with the hardware.

Now that our profession has matured somewhat, good programming is recognized as having the additional qualities of clarity, straightforwardness, functional modularity, and maintainability. Good data processing management ensures that good quality code is produced; good quality code is practically immortal.

In an organization where program development is an on-going and vital part of the operation, programming methods and efficiency are areas that demand careful attention. Streamlined procedures, consistent adherence to standards, and attention to the development of good programming tools continue to pay dividends year after year. The development of programming tools is an area where sufferers of TGM are often denied, since compiler level languages do not offer much in the way of tool-building capabilities.

Most assembler level languages, however, provide macro processing capabilities. The macroinstruction represents one of the best means for building effective programming tools. These tools are as important to the professional computer programmer as a trowel and spirit level are to the brick-layer.

My experience has shown that a good ALC programmer with a well developed toolbox of macros will often outperform a compiler-language programmer nearly two to one in day to day applications. Despite popular misconceptions (around TGM-infected installations) and depending on the application, of course, some assembler programs are up for service in approximately 60% of the time and cost of what a compiler language implementation would be. For complicated data manipulation tasks we find the gap widens even further. Therefore, time and cost are not necessarily a reason for disqualifying assembler language for most applications.

THE NOT-SO-PROFESSIONAL

Be wary of professional data processors who discount and reject assembler level languages across the board for sundry and often vague reasons. In nearly all cases, such persons do not really know assembler languages nor how the computer instruction set actually functions. TGM pro-

vides a convenient camouflage to cover their ignorance and lack of technical depth.

Some applications call for programming a language, others for programming a computer. As a technical manager make sure you know who on your staff is a computer programmer and who is a language programmer. Encourage your language programmers to learn how your computer works and begin using assembler occasionally when the situation calls for it. Work on developing or acquiring good programming tools and promote their use in your organization. A good macro library developed for a specific line of business can have a tremendous effect on lowering cost, ensuring timely delivery and improving the reliability of programs.

If you are an officer or administrator of a computer based operation, be sure your technical management is competent and has *all* the skills necessary to do a professional job. If your managers tell you the organization needs a larger computer, try to find out just how efficiently you are using the present one.

The most effective cure to the problem of spreading TGM is realizing there is nothing inherently wrong or bad about assembler programming. For many applications assembler programs may well be the best all around solution.* A professional data processor should have no prejudices or biases about any programming language. Rather, the language should be chosen based on the application and situation.

*

R. EDWARD MITCHELL, JR.



Mr. Mitchell is presently a senior consultant with Martin Marietta Data Systems in Bethesda, Md. He is a cofounder and was president of U.S. Robots, Inc.,

also in Bethesda, and for eight years made his living as a consultant specializing in computer information systems and advanced programming methods. He first began writing programs as a field technician for early second generation machines.

Consider Cincom

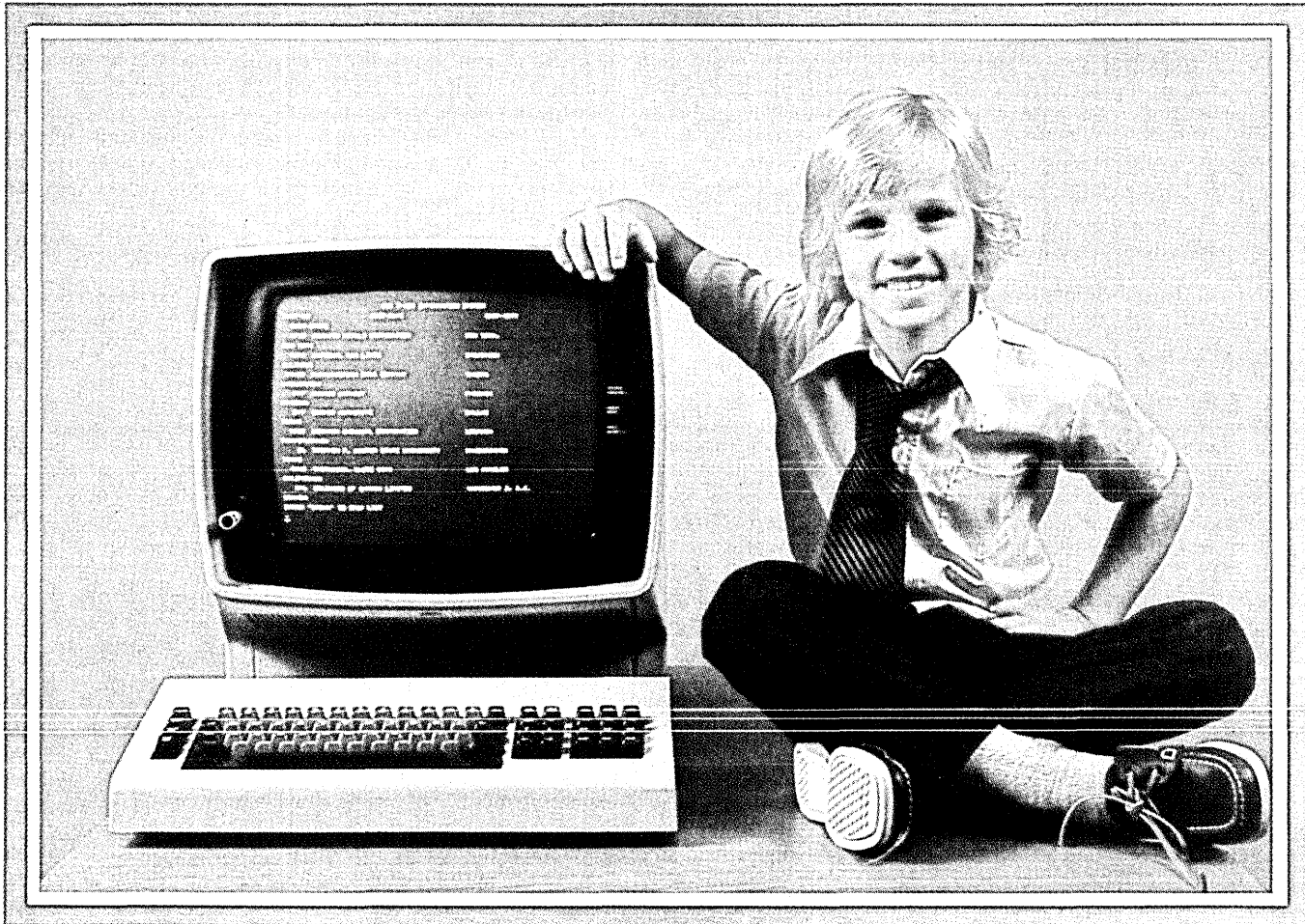

**We offer an interactive, on-line data base query facility
so easy to use - it's almost child's play.**

Experience gained from serving over 2,000 **TOTAL® Data Base Management System (DBMS)** users worldwide has taught us that the success of a DBMS is measured by how rapidly the data resource can be transformed into end-user information.

For many types of information requirements, traditional programming techniques are a time-consuming, costly bottleneck. Cincom's new query facility eliminates this programming need for both ad hoc and repetitive inquiries into the **TOTAL® DBMS**. It provides prompt decision/action information to non-programmer personnel in a logical format.

As proof, we tested our query facility's ease of use with

a random group of children. They mastered the basic inquiry capability in less than two hours. All functions in less than a day. If you consider this type of increased productivity and visibility, this type of bridge over the programming barrier, to be important to your data processing group, shouldn't you consider Cincom?

We're located in 42 cities. In 11 different countries. And on every continent in the world except Antarctica. Contact us for additional information.

U.S.A. 2300 Montana Avenue Cincinnati, Ohio 45211
(513) 662-2300

International 17-19 Rue Montoyer 1040 Brussels, Belgium
(02) 511-65-48

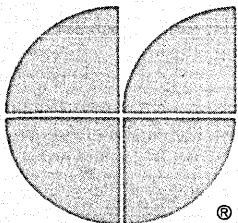

Cincom Systems, Inc.

The TOTAL Information Systems People.

Managers frequently find themselves pushing the limits of their department's abilities to adapt—and not knowing what the limits are.

GAUGING THE IMPACT OF CHANGE

by Joseph R. Matthews
and Robert J. Smith

Change is an integral part of an organization's life as well as of an individual's. Be it a new market opportunity, technological breakthrough, management reorganization, or government regulation and compliance procedure, change is an everyday occurrence. Some

There is nothing permanent except change.

Heraclitus

changes are unavoidable; others are sought. Some come down as mandates; others sneak in before they are recognized.

Data processing managers are somewhat unusual in the amount of change they experience. Theirs is one of the most volatile fields to begin with, but in addition they must cope with changes in other parts of the organization as well as in their own. They frequently find themselves pushing the limits of their department's abilities to adapt—and yet may have no idea what those limits are.

We contend that each data processing department has a tolerance level for the amount of change it can accommodate without serious disruption of its performance, and that the manner in which change is planned and managed determines the quality of dp services delivered.

Data processing has never been a static function. There have been frequent conversions of hardware and software, for example, all along. Thus the manager has always had two major re-

sponsibilities: keeping the system operational and managing change.

The conflict between the two responsibilities is apparent. The first is based on steady state assumptions while the second is based on altering those steady states. And while the majority of lessons learned by the manager both through education and experience focus on the steady state side, people are left to fend for themselves in learning to manage change.

Work groups are really quite delicate mechanisms balanced within a patterned network of pressures. Each of the major subcomponents—the task, organizational structure, people, and technology—are interrelated. A change in one will impact all the others. Further, any change in the kinds of tasks, form of technology, reporting relationships, and personalities may have a stressful and

disruptive (but perhaps unanticipated) impact on the overall performance of the work group.

Thus for example, a change in operating systems (technology) may

Knowledge is change—and accelerating knowledge acquisition, fueling the great engine of technology—means accelerating change.

Alvin Toffler

require new skills (tasks) leading to the need to hire new individuals with experience in the new operating system (people). Then new links must be formed within the social networks, and new formal and informal rules must evolve. This alters roles for the members of the work group. These changes do consume resources, including tangible ones and the intangible psychic and social energies

THE COMPUTING READJUSTMENT SCALE	
EVENT	VALUE
Hardware & Software	
1. A change in generation of machine (same vendor)	<u>500</u>
2. A change of CPU vendors, switching from one vendor to another	_____
3. A change in the number of CPU's	_____
4. A change in size of CPU, a significant upgrading	_____
5. Switching peripheral equipment vendors	_____
6. Installing a new type of peripheral equipment (e.g., CRT's, key-to-disk)	_____
	⋮

Fig. 1. Among other questions, the survey instrument asked respondents to weight kinds of changes in dp against a standard of 500 for a conversion from one generation to another in the same manufacturer's line.

spent adjusting to new roles, relationships, and routines.

Experienced data processing managers are sensitive to these stresses and have developed over time an intuitive ability to assess the time and effort required for a work group to readjust to the stress resulting from major changes. Managers with "battle scars" recognize the limits of the group's adaptability and the consequences for reduced system performance if these limits are exceeded. These managers would be hard pressed, however, to make explicit their intuitive insights and the subtle distinctions between the various types of change events.

Managers have learned their change readjustment estimating skills only after some bitter and perhaps costly experiences. Further, there is seldom any assurance that a once-successful estimator will continue to be successful. It appears that a tool for formalizing the collected wisdom and experience of many managers would be helpful. Our Computing Readjustment Scale (CRS) is designed to fill this need.

By "Computing Readjustment" we mean to represent the variety of factors necessary to cope with changes in current computing practices. Examples of readjustment include: planning and scheduling the proposed change, reallocating personnel, hiring new personnel, meeting time constraints, bringing in outside experts, using vendor service personnel, working overtime, etc.

BUILDING THE SCALE

The necessary data to develop the Computing Readjustment Scale was provided by 120 survey respondents. (Table 1 provides data concerning their characteristics.) Each was asked to compare the readjustment necessary to successfully cope with individual changes against the readjustment represented by converting from one computer generation to another within the same vendor's line. The generation conversion was assigned an arbitrary value of 500 on the questionnaire. Respondents were asked to weight other changes, such as a change in the number or size of cpu's, against that standard. (See Fig. 1.) The resulting scale is a first step in trying to bring a greater degree of predictability and reliability in estimates of the resources necessary to successfully implement a particular change. Fig. 2 presents our Computing Readjustment

Change of cpu vendors	100	
	73	Implementation of data base management system
Change in relationships between computer installations, such as centralization	65	
	61	Change from batch to on-line system
Change in operating system	47	
	43	High turnover of systems analysts
Software support discontinued by the vendor	38	
	37	High turnover of applications programmers
Change in key systems programmers	37	
	37	Changing demands placed on the system by users
Change in development priorities for a major new system	36	
	36	Changes in dp department location
Change in top dp management	36	
	35	Change in generation of machine (from same vendor)
Addition of a major application	34	
	34	Moving cpu to another location
Acquiring and installing an application from a similar organization	33	
	31	Adding a new (to the site) programming language
Acquiring and installing an application from a cpu manufacturer	30	
	28	Acquiring and installing an application from a software house
Change in the organizational structure of the dp department	27	
	27	Change in the organization's top executive officer
Change in reporting requirements imposed by a higher authority	27	
	24	Change in demand for peak processing
Change in number of cpu's	24	
	22	Installing new types of peripherals
Switching peripheral vendors	22	
	21	Significant upgrading of cpu size
Changing the number of shifts the computer is operational	20	
	18	New release of an operating system
High turnover of data entry personnel	18	

Fig. 2. The Computing Readjustment Scale represents the collective experience of the 120 respondents. Users may wish to compile their own index, but this one at least passes some common sense tests.

Changes in technology require the most difficult readjustments.

Scale. This figure contains the magnitude of the computing change events on a scale of 0-100 (the mean score of each event divided by the value of the one event with the largest mean value).

The scale is intuitively attractive because it provides a relatively easy to understand index for a variety of diverse changes involving hardware and software, structure, personnel, and operations. In addition, the relative ranking of the seriousness of the various change events appears to pass the test of "common sense"; that is, for instance, a change of cpu vendors or the implementation of a data base management system is much more problematic and requires considerably more readjustment effort than the adoption of a new programming language and this shows up in the index numbers. The significance of the scale is that it provides a ratio of the likely readjustment necessary to accommodate a particular change. (At present we assume, but have no basis on which to judge, that the scale is linear rather than curvilinear or exponential.)

Notice that the group of change events that are technology-based pose serious readjustment problems that should not be underestimated. Consider the top 16 change events, as shown in Table 2. The magnitudes of the computing readjustment scores for Technology are almost twice the scores of either People, Tasks, or Structure. While changes in technology are often couched in terms of positive benefits to the organization, the impacts in terms of required readjustment are significant. In addition, changes in Technology are likely to cause additional adjusting changes in the areas of People, Tasks, and Structure.

It may well be that managers will want to determine their own ratings for the change events presented here. That makes good sense, as installations and people differ in their reactions to change. The distilled experience represented in the index numbers we've compiled will at least aid in the process of developing a personal scale.

PUTTING IT TO WORK Once created, the Computing Readjustment Scale may be used in a number of ways, as the following few uses illustrate.

How do your personal experiences compare with the Computing Readjustment Scale?

Recollect your experiences in coping with various change events and

CHARACTERISTICS OF RESPONDENTS

Type of Organization	%	Computing Environment	%
Banking/credit	8%	Batch only	3%
Dp services	3%	Batch, multiprogramming	9%
Education	1%	Batch & on-line	22%
Gov't, local	21%	On-line, multiprogramming	66%
Gov't, state & fed.	6%		
Health	3%	Respondent	%
Insurance	7%	Provider of dp service	86%
Manufacturing	27%	User of dp service	4%
Petroleum	4%	Other	10%
Public utilities	7%		
Trade, wholesale & retail	3%	Average Years of Experience	
Transportation	3%	In present position	4.2 years
Other	7%	With this organization	8.9 years
		In data processing	13.7 years
Number of Employees	%		
1 - 49	3%		
50 - 99	3%		
100 - 249	11%		
250 - 499	15%		
500 - 999	16%		
1,000 - 1,999	17%		
Over 1,999	35%		

Other organizational data: the mean machine size, measured by main memory, was over 1MB; 54% had dbms.

Other respondent data: 95% male, average age was 43, 78% have at least one degree.

Table 1. The survey sample was spread over many industries and organization sizes, but definitely was biased toward the experienced dp services provider in a large, sophisticated shop.

LOOKING AT THE TOP 16

CRS RANK	PEOPLE	CRS VALUE
6	High turnover of systems analysts	43
8	High turnover among applications programmers	37
9	Change in key systems programmers	37
	TASKS	
7	Software support discontinued by vendor	38
10	Change in demands placed on system by users	37
11	Change in development priorities	36
15	Adding a major new application	34
	TECHNOLOGY	
1	Change of cpu vendors	100
2	Implementing a data base management system	73
4	Change from batch to on-line system	61
5	Change in operating systems	47
14	Change in generation of cpu (same vendor)	35
	STRUCTURE	
3	Change in relationships between computer installations, such as centralization	65
12	Change in dp department location	36
13	Change in top dp management	36
16	Moving cpu to another location	34

Table 2. Changes in technology have a more dramatic effect on dp, overall, than do any other changes. Note that a "change in relationships between computer installations, such as centralization," which is listed under "Structure," may also involve a change in technology. It too is ranked very high in impact.

OUTPUT CONTROL.

**How Honeywell's
Page Printing System
consolidates the work of
as many as six impact printers—
and associated punches,
perforators, cutters,
collators, stackers,
and addressing machines.**

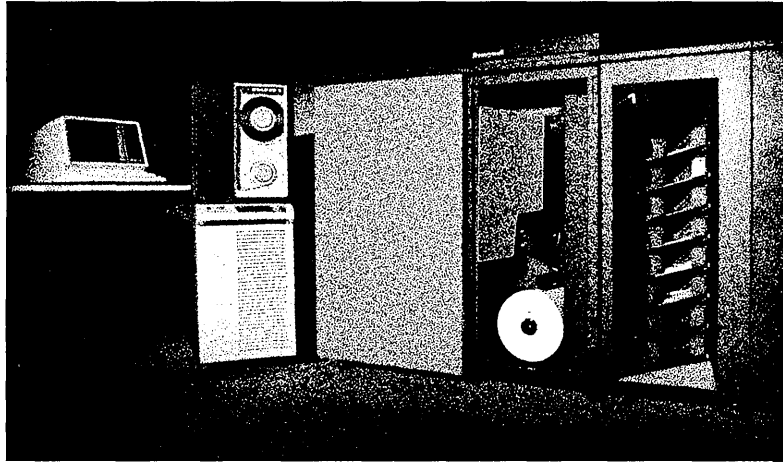

With our system, you get the advantages of total performance without bottlenecks. And users get better finished products without delays. Because Honeywell's non-impact Page Printing System continuously delivers more original copies at higher speeds with increased flexibility and greater cost control.

In fact, at printing speeds of up to 600 pages per minute, our systems are producing as many as four million pages per month for companies in industries like manufacturing or distribution, banking or finance, government or education, and insurance or services. And they do all this with output from IBM, Burroughs and Univac, as well as Honeywell computers.

Quality Control.

That's not all. Our system not only prints variable data, but also prints the forms and punches, perforates, collates, and stacks the pages. Each printed character is crisp, clean, and sharp. Every line is true and even. Each page is an original without carbons, smudges, or diminished quality. Which gives you more satisfied users than ever before.

And our system lets you choose the form size, type font (with upper and lower case), hole punching, color, selective blanking or suppression, and individual addressing or routing.

Cost Control.

What all these advantages give you is a sure way to control the mounting costs of hardware, personnel, and forms and

inventory. And, at output rates of at least 400,000 and as many as 4,800,000 pages a month, a single Honeywell Page Printing System can meet the most demanding needs.

Performance Control.

So, if you want increased throughput, improved quality, cost efficiency, and more flexibility than you've ever had before, consolidate your efforts towards consolidated control. With the Honeywell Page Printing System.

For more information, write Honeywell Information Systems, 200 Smith Street (MS 487), Waltham, MA 02154.

Honeywell

The manager figured that installing a new forecasting application was about as difficult as installing a new operating system release. He was wrong.

compare them to the scale. Are you reasonably close to the scale? If you are not very close to the rankings in the scale, not to worry. Some of the change events had a great deal of variations in the values assigned by the respondents (for example, change events Number 1, 2, 3, 4, 6, 7, 8 and 11 all had standard deviations in excess of 10 on the original scale which used 500 as a base). This suggests that some differences may spring from using

cpu's from different manufacturers, from the experience and capabilities of the dp manager, and from different management strategies. The other change events had reasonably small standard deviations. Were the sample size increased dramatically, the positioning of some of the change events might move a bit but we would not anticipate major shifts in position.

Are there benefits to preparing

baseline cost data for my organization?

For a recent project, ascertain with some degree of certainty the actual dollar and other intangible costs involved in implementing that change. It will then be possible to predict future costs of planned projects using this baseline data. Are the planned projects resources roughly proportional to the change event's position on the Computing Readjustment Scale? If not, then a review of the project might be in order to discover if overlooked areas might contribute to a schedule delay or cost overrun.

Is an average CRS score of use to my organization?

Compute your organization's CRS cumulative score for each of the past three to five years. Examine each year to see if all of the changes made were implemented on time and within budget. For those years that there were overruns, assuming a relatively high CRS score, perhaps your organization exceeded its change tolerance. Now you will be in a position to determine the current year's CRS score; it may suggest whether your current change activities are likely to face unexpected problems and serious delays.

Are there any uses of the CRS that may aid in staffing the data processing department?

Planned change events can be reviewed for their likely personnel requirements. The CRS score for each of these planned changes could be reviewed to determine whether they are in rough agreement in terms of total resources necessary to implement the changes, based on benchmark data established earlier. When compared to current and projected staff levels, this review may signal the need for contract personnel for peak periods or specific skill requirements necessary to successfully implement a planned change.

Could the CRS be used to control or schedule change in the data processing department?

Yes. Planned and known future change events could have their CRS score determined. Once known, this information could be used to review the implementation schedule of change events to determine whether some of the periods with high CRS scores might be adjusted or rescheduled to smooth out the high points of readjustments.

Are there any management uses for the CRS?

Several uses of the CRS come to mind concerning the management of the data processing department. These include using the CRS score as a basis of determining whether too much or too

Sola "Ultra-Regulation": Plug it in where you need it most.

Brownouts, transients and line noise can cause electronic office equipment to malfunction; drop digits, lose memory, and suffer inefficient operation. Field service people may tell you to install a dedicated line. Still others will suggest an ultra-isolation transformer. But both of these are expensive and inflexible compared with Sola's Mini and Micro/Minicomputer Regulators with "Ultra-Regulation" — complete protection for your electronics.

Sola's "Ultra-Regulators" do everything a dedicated line or an ultra-isolation transformer does and more. They eliminate transients and provide complete isolation from line surges. The resulting waveshape contains less

than 3% harmonic distortion. What's more, each unit is portable. You can plug it in where it's needed most at any given moment. And it's UL listed.

Sola Micro/Minicomputer Regulators provide better than 120 db common mode noise rejection; 60 db transverse mode noise rejection, as well as reliable brownout protection. Output remains within NEMA voltage specification of $\pm 5\%$ for input voltages as low as 65% of nominal.

Before you invest in ultra-isolation or a dedicated line, investigate Sola's Mini and Micro/Minicomputer Regulators — in stock for immediate shipment through your local Sola stocking distributor. Call or write for free literature.



1717 BUSSE RD., ELK GROVE VILLAGE, ILLINOIS 60007 (312) 439-2800

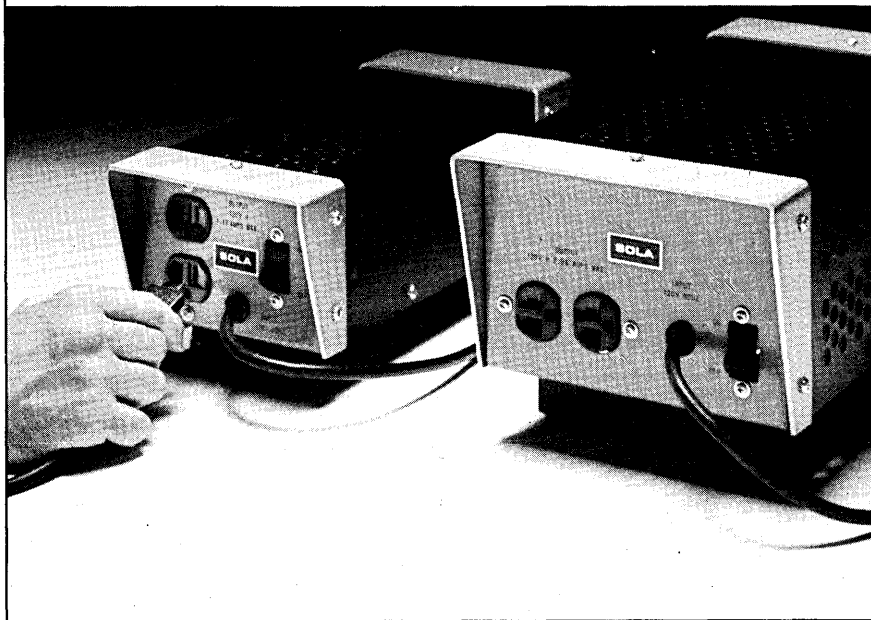

CIRCLE 196 ON READER CARD

Data Communications Problems? Meet The Portable Problem Solver

Spectron D-301 DATASCOPE

The Field Service Standard For Network Hardware and Software Monitoring

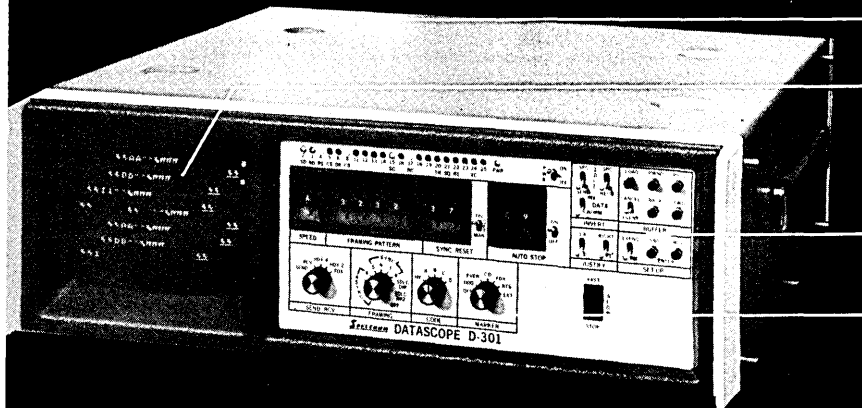

The fully microprocessor-based D-301 is designed for portability. It's a 5½" high x 16" wide x 17" deep, brief case size, and weighs only 25 lbs. It has a built-in ease and simplicity of operation, as do all DATASCOPIES.

The time-correlated full-duplex CRT display allows maximum monitoring flexibility. Send and receive data are separately (and simultaneously) controlled for speed, language (i.e., HEX, ASCII, EBCDIC), synchronization, and number of bits per character.

The D-301 captures full duplex data at speeds up to 72,000 bits per second and stores it in its large 262,000 bit buffer for replay under operator control. A search feature with Auto-Stop (up to 4 selected characters) permits the rapid scanning of the entire buffer contents.

The D-301 provides for switch-selectable full duplex, half duplex and simplex operation; SDLC, Synchronous, Asynchronous, and Isochronous transmission; and 5, 6, 7, or 8 level codes. Right or left character justification, bit inversion and character reversal are independently controllable for each side. Complete interface breakout and L.E.D. display.

The DATASCOPE is the window into your communications network which shows every character sent or received. Hidden errors become visible; complex problems become solvable.

Portable, Inexpensive,
Exceptionally Capable
The D-301 DATASCOPE
\$4,900.

SPECTRON
CORPORATION

For Information:

344 New Albany Rd.
P.O. Box 620
Moorestown, NJ 08057
(609) 234-5700

TWX: 710-897-1359
Telex: 83-1488

CIRCLE 131 ON READER CARD

Anticipating changes that follow other changes.

little resources are being budgeted to implement a particular change. If there are several alternatives that involve different change events to solve a particular problem, the CRS score for each change event could be used as *one measure* of the likely impacts implicit with each alternative. In addition, the CRS could be used as a means of anticipating changes that will likely follow the introduction or implementation of any other change. These aftershocks can require substantial readjustment by the data processing department just as the aftershocks of minor earthquakes often inflict serious damage to an area already softened up by a major quake.

Several data processing managers expressed interest in using the CRS as one reference tool in planning the necessary resources to implement a particular change. One manager, in particular, felt that he should reconsider and review an estimate of the resources for a planned change. Two weeks prior to seeing the CRS, this manager had installed a new release of an operating system, which has a value of 18 on the CRS. Now the manager was planning to install a new budget forecasting application borrowed from a "sister" organization. The

manager had planned to use the same amount of resources for implementing this new application. This new change event ranks considerably higher on the CRS scale, however, with a value of 33. Realizing this, the manager decided to carefully reexamine the project estimates and to check the experiences of some of his counterparts. He found he'd overlooked some programming and had to increase the resources allocated for installing the new application.

A Computing Readjustment Scale provides a rationale for assessing the relative impact of a specific change, at least in broad terms. Using one, manager and systems personnel can review the number and sequence of changes scheduled for their installations to determine whether too much is being attempted in too short a period. Further, that use of the scale should improve its utility by tuning the index numbers to fit a given environment.

Whether the user accepts the index numbers compiled here from 120 persons' experiences or derives a new set from his own experience, he will have one more tool for managing change. And unlike most others, this one improves with age. *

J.R. MATTHEWS

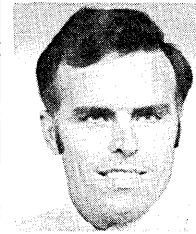

Mr. Matthews is managing director of J. Matthews and Associates, a Cypress, California consulting firm.

Formerly he was associated with the URBIS Project being conducted by the Public Research Organization at the Univ. of California at Irvine. He also has been a programmer and systems analyst.

R.J. SMITH



Mr. Smith is an associate professor of management in the School of Business Admin., California State Univ., Long Beach. He has been involved in the development of information systems for public and private organizations, and teaches Management Information Systems.

New Remote Control System lets you reconfigure your data network in seconds or switch to backup anywhere your telephone line reaches.

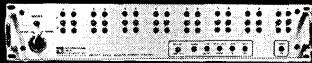

Now, from one tech control command center, you can assure uninterrupted data communications anywhere on the globe. Our microprocessor based 8900R Remote Control System gives you remote status reporting from every station in your data network. When trouble occurs, it enables you to reconfigure your network or switch to backup equipment at the remote site in seconds

— right from your tech control center. The 8900R, IDS's newest advance in remote tech control.

- City to city network control using any asynchronous dial-up or leased line modem link.
- Allows remote control of all standard IDS series 8900A, B switches.
- Can be expanded to control up to

4096 A, B switches at each site.

- LED's automatically indicate status of remotely controlled switches.
- Proprietary error correction technique assures error free remote operation.
- Microprocessor based.
- Key lockout to prevent accidental A, B switching.

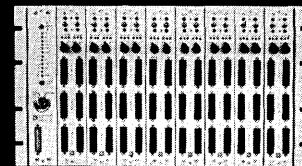

INTERNATIONAL DATA SCIENCES, INC.

Seven Wellington Rd., Lincoln, R.I. 02865 Tel: (401) 333-6200 TWX: 710-381-0285 Export: EMEC, Box 1285, Hallandale, Florida 33009

CIRCLE 163 ON READER CARD

how DOCU-MATE™ and the structured filing concept improve systems and programming productivity

A thorough and complete data processing documentation library is like motherhood and the flag. Everyone is in favor of it. The real problem lies in organizing it and making it work. That's where our DOCU-MATE System comes in. Starting with the problems, we designed solutions in the form of products that make it easy to file and access virtually every size and shape of documentation . . . to intermix different sizes and shapes in the same filing equipment . . . to move documentation from filing to reference mode and vice-versa while keeping it in the same filing device . . . and to structure workable standards for managing and controlling all documentation.

The heart of the DOCU-MATE System is the hanging cartridge. It provides center hook lateral filing or end hook drop filing . . . snaps open or closed with the flick of a finger . . . and has highly visible end and top labeling areas.

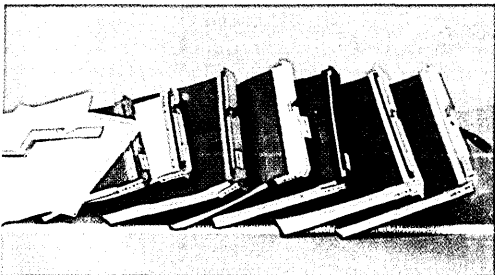
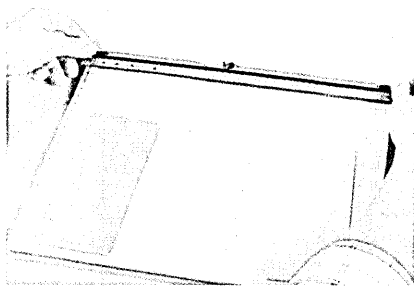

Along with other DOCU-MATE filing devices, cartridges fit compatibly into a wide variety of

filing and referencing equipment that allows almost unlimited flexibility in the planning of central documentation libraries and development support libraries, and individual work stations.

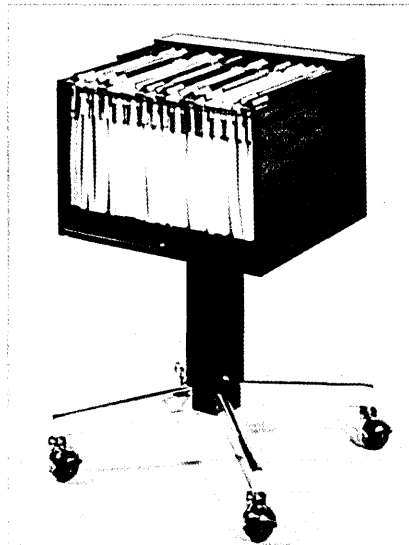

The DOCU-MATE System is the key you are looking for to make your documentation library system work. It will help you to improve project control, increase systems and programming productivity, improve interdepartmental communications and reduce the cost of maintaining your documentation system. In less than two years

since its introduction, it is now in use by over 3,000 companies in the U.S.



A Subsidiary of Barry Wright Corp.

For complete details circle reader's service number or write to: Wright Line Inc., 160 Gold Star Blvd. Worcester, Mass. 01606



Conference and exposition for information management people will begin to set some records of its own in Chicago, Oct. 16-19.

INFO 78: CATCHING UP WITH THE NCC

by Tom McCusker, Senior Editor

It isn't quite a National Computer Conference with its 350 exhibitors and attendance of 57,000. But Info 78, the Information Management Exposition and Conference, which opens in Chicago Oct. 16 for a four-day run, is beginning to set some records of its own. For the first time in its five years, Info 78 has every major mainframe company, except Control Data, as an exhibitor. It has just about every minicomputer manufacturer in the show, with the exception of Digital Equipment Corp. (and Data General, which won't be exhibiting this year even though it's been in previous Info shows—explaining that it's re-directing its show activity to an ambitious schedule of its own road shows).

Some 60 firms are exhibiting in Info for the first time and 38 companies who exhibited in last year's event in New York City have increased their exhibit space by a total of 11,000 sq. ft. Its 150 exhibitors in last year's show in New York have increased to about 200 this year and the 44,000 sq. ft. of exhibit space has soared to 70,000 sq. ft. this year in Chicago's huge McCormick Place. "And that space," says Richard Wolcott of the show management firm of Clapp & Poliak which puts on Info shows, "is the very same amount of space that the National Computer Conference occupied during its first run in New York in 1973."

Attendance, which last year reached 15,000, was expected to be about the same this year. But two months before the show was to open, about half of the exhibitors already had ordered 120,000 admission tickets to send to customers. So the turnout, as with the NCC in Anaheim last June, is anyone's guess.

REPLACEMENT FOR THE JOINT CONFERENCES

The Information Management Exposition and Conference was started in the Fall of 1974 as a sort of replacement to the semiannual Spring and Fall Joint

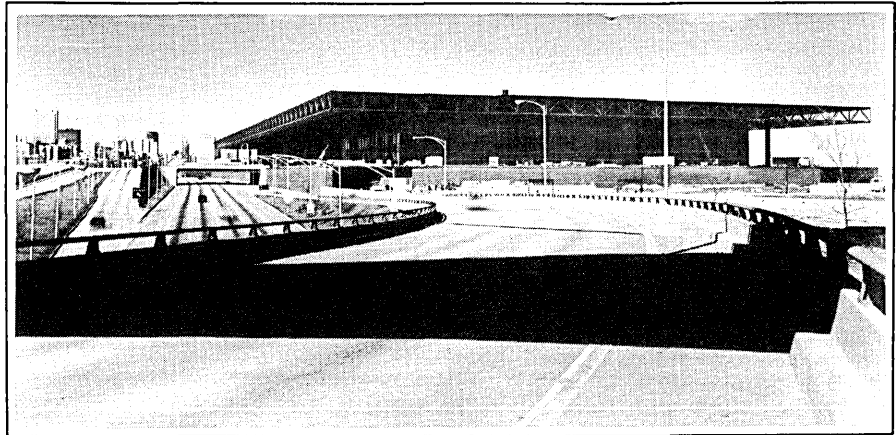

Info 78's home this year is huge McCormick Place in Chicago, Oct. 16-19.

Computer Conferences, which in 1973 were consolidated into a single summer show. But its organizers took a different approach to the conference program by directing its content to management aspects rather than to technical approaches. The program for its first conference was put together by the American Management Assn.

It has pretty much stuck to this format, even though Clapp & Poliak's Wolcott still worries about the interests of his attendees. "A lawyer came up to me once and complained the content of the conference wasn't technical enough," Wolcott said. "And he was a lawyer!"

Theme for this year's conference is "strategic planning in the information age," which the sponsors say was selected to convey the need for a corporate strategy in gathering, storing, retrieving, and disseminating information. And there are plenty of sessions directed to technical subjects in order to please the estimated 2,500 persons who attend the conference part of the Info event.

For instance, Howard Anderson of the Cambridge consulting firm, The Yankee Group, will describe the telephone company's Advanced Communications Service in a session on Oct. 16; and Steven M. Farber, of Boeing Computer Services, will talk about communications technology alternatives in a

session on Oct. 17. There is a session on Oct. 18 discussing how to manage the proliferation of minicomputers, featuring two users and a marketing man from minicomputer manufacturer Data General. Another session on Oct. 18 will be directed to exploring ways to improve the productivity of software development.

The conference is broken down into three principal sections covering Information Management, Information Technology, and Office Automation.

In addition to these, smaller groups of sessions will be directed to applications in specific areas of interest, such as the use of information management in manufacturing, banking, corporate financial, insurance, and hospitals.

And there will be keynote speakers. At an opening session on Monday, Oct. 16, William J. Mueller, vice chairman of the accounting firm of Arthur Anderson & Co., Chicago, will speak on "Crossroads in Information Management." Mueller's message is that executive management now must be able to use advanced management techniques brought about by technology. He talks of computer based methods for capital budgeting, productivity analysis, risk assessment and what-if modeling. "Hitherto impractical to implement, they're now available for planning and

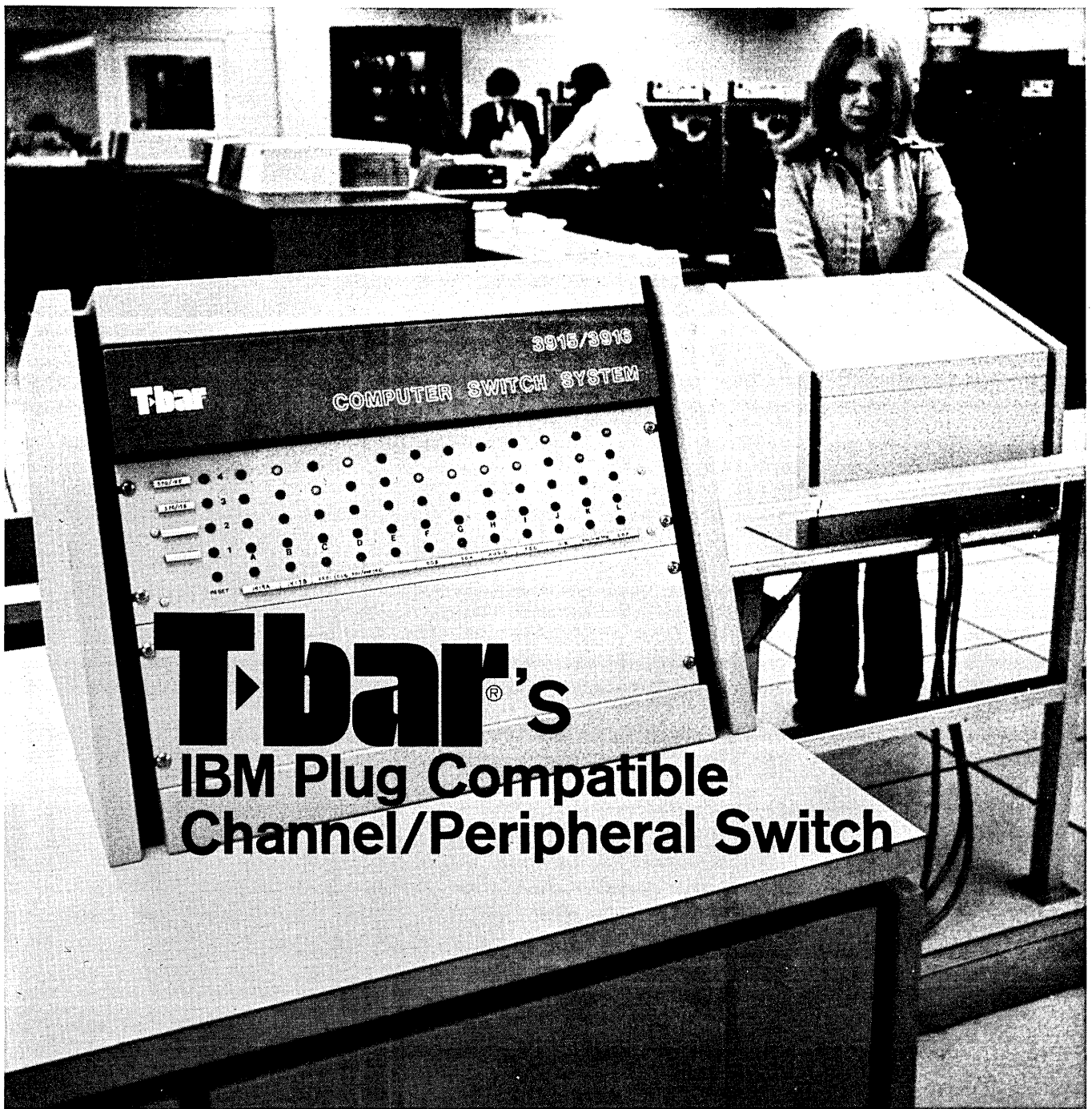

Tbar's
IBM Plug Compatible
Channel/Peripheral Switch

T-BAR 4x12 Channel/Peripheral Switch Installation

For more efficient use of peripherals

T-BAR's 3915/3916 matrix switches for use with ITEL, AMDAHL and IBM 360/370 type computers permit load balancing by sharing printers, tape drives, discs and front ends between CPU's. Greater configuration flexibility is attained by using the larger T-BAR matrix sizes — up to 12 computer channels and 12 strings of up to 4 peripherals each — 12x12.

The 3915/16 computer switch speeds system restoral when mainframe trouble occurs. Pushing a button interchanges peripherals between a failed and back up system or reconfigures a computer room for multiple tasks on the same mainframe.

The switch can be controlled from an operator's position up to 200 ft. away.

Tbar INCORPORATED

COMPUTER SWITCH DIVISION
 141 Danbury Road, Wilton, CT 06897.
 Telephone: 203/762-8351. TWX: 710/479-3215.

Executives can make their operations more productive by improving existing information systems or by creating new ones.



Show and exposition have been drawing about 15,000 and exhibit space has increased considerably to 70,000 sq. ft. from about 44,000 sq. ft. last year in New York's Coliseum.

decision-making because of the great advances in computer technology and data communications.”

So, Mueller says, information systems managers not only have the opportunity to introduce these tech-

niques to their executive management, but they will also need to integrate their own system planning with strategic corporate plans and develop relationships with other corporate executives. He says traditional dp management now has a

much broader role in a company.

A second keynoter, William E. Reidy, executive vice president-technical services with Kraft, Inc., Glenview, Ill., will talk about new problems facing the dp manager in a highly complex environment. In a speech entitled “New Opportunities for the DP Manager,” Reidy will offer some guidelines for the information manager to follow in applying new technologies to the processing and utilization of information in his organization.

OFFICE OF THE FUTURE

The third keynoter, Vincent Byrne, director of management and administrative sciences with Xerox in Stamford, Conn., will discuss the office of the future in a talk entitled “The ‘1980 Office’—a View from the Top.” He’ll discuss how management can plan, coordinate, and use the new technologies in automating offices within the next decade. Byrne will talk about how data processing, word processing, and data communications will be merged, and what will be the impact on multioffice operations and office organization.

Although the conference organizers say they have trouble defining “information management” precisely because the concept expands with the development of new technologies, they say its scope at present includes: data processing, word processing, data communications, dictation systems, micrographics, electronic mail, duplicating, telephone systems, records storage and retrieval, and office automation. And they say the emphasis at the show and conference is not on technology but on applications. “The purpose is to demonstrate how executives can make their operations more productive by improving existing information systems; or creating new ones,” the show organizers say.

Some titles of sessions in the dp section of the conference indicate how they’ve implemented the planning theme: Information Systems Planning for the 1980 Corporate Environment; Project Management Techniques and Standards for EDP; Long Range Planning for Data Communications; Human Resource Management to Increase Productivity; Capacity Planning—A Necessary Component of DP Management; Managing the Proliferation of Minicomputers; Improving Productivity in Software Development; Planning for Disaster Recovery; Planning for the EDP Audit; Preparing the Feasibility Study for a New Application; Planning for the Merging Trends in Computer Architecture; Interactive Graphics—

Sorbus: still the one.

The people who know the best — manufacturers, distributors and end users of data processing and data communications equipment — have spoken.

Your fellow-professionals rate SORBUS the “BEST” Maintenance Service Company in the business, according to the 1978 *Data Communications* Brand Preference Survey.

SORBUS was selected for: Best Technology, Best Price/Performance Ratio, Best Service Organization and Most Prefer to do Business With.

SORBUS is also the leading maintenance service company in the general data processing field. (Winning four straight *Datamation* magazine brand preference surveys since 1974.)

SORBUS. Providing maintenance services for 70,000 pieces of equipment. Working for over 60 OEM's, and over 9,000 end users.

If you suspect the service you're getting is less than the best, please give us a call.



Sorbus



Sorbus Inc./A Management Assistance Inc. Company
150 Allendale Road, King of Prussia, PA 19406
(215) 265-6700

UDS — the Symbol of Leadership in Data Communications

If your datacomm system fits anywhere in the spectrum at 4800 bps or below UDS has the modem you need! The new microprocessor 203 leads the pack, but UDS has CMOS 201s, plus 103s, 202s and ACUS. For super economy you can specify the 12 • 12, which gives you full duplex 1200 bps communication over only two wires.

Most models are available in direct-connect configuration.

For multi-channel capability choose our RIM-13 (12 channels) or RIM-16 (16 channels) with

any mix of modem cards.

Contact Universal Data Systems, 4900 Bradford Drive, Huntsville, Alabama 35895. Phone 205/837-2100, TWX 810-726-2100.

CONFIDENTIAL COMMUNICATIONS UDS
UNIVERSAL DATA SYSTEMS 

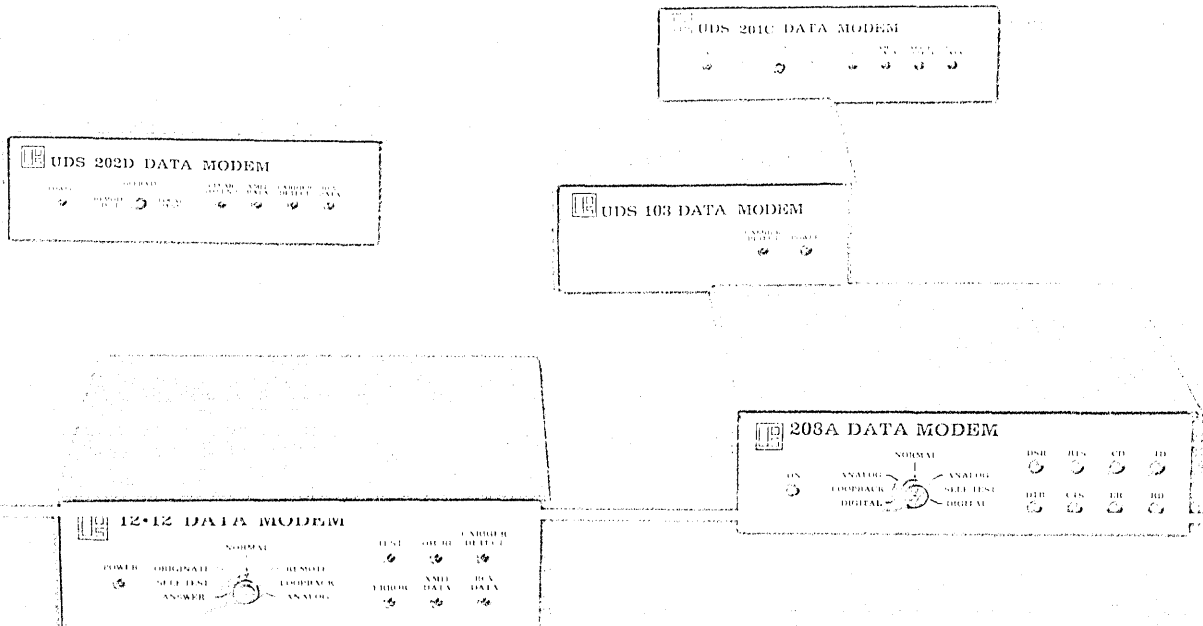

FOR SPACE MISSIONS AND GROUND APPLICATIONS... THE 700/UETS™ FILLS THE BILL

For its Space Shuttle Program, NASA needed a terminal that could interface with an array of different computers and that could emulate any number of different terminals—the **MEGADATA 700/UETS (Universal Emulating Terminal System)** filled the bill. At the Johnson Space Center, the **700/UETS** is now being used not only as a program control and status device for Shuttle flights, but also as a true emulating system that performs non-mission related services—for example, developing programs that are typical of on-line interactive terminal applications.

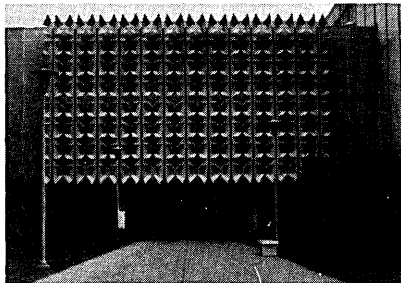

Command Center of Johnson Space Complex

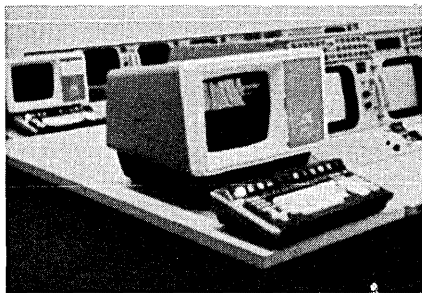

Space Shuttle Control Center

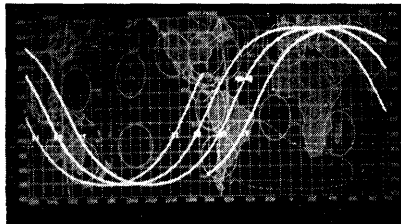

Satellite Global Tracking Map

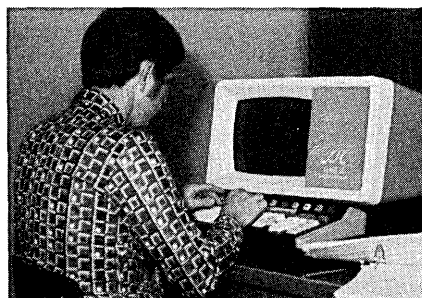

UETS Terminal
Being Used in Data Entry and Test Mode

Exotic applications the **UETS** takes in stride. But most of all it provides its many users with a cost-effective solution to the most complex data handling and communications problems. If you are a multiple computer user who is tired of using scores of different terminals, let us show you how **ONE UETS** can replace a host of terminals, simplify your operations, reduce maintenance complexity, and save you money to boot!

Call or write TODAY to find out more about the **700/UETS**, our entire family of Series 700 applications-oriented programmable terminals, and our extensive software capabilities.

MEGADATA CORPORATION 

35 Orville Drive • Bohemia, New York 11716 / Tel. 516-589-6800 • Telex 14-4659

Central Regional Office -

2200 E. Devon Avenue • Suite 217 • Des Plaines, Illinois 60018 • Tel. 312-296-1900

Western Regional Office

15910 Ventura Boulevard • Suite 800 • Encino, California 91316 • Tel. 213-990-9777

The right people
will attend.

New Approaches to Data Analysis for Management Planning and Decision-Making; Converting to Distributed Data Processing; Front-end Systems to Speed Up and Improve Data Entry; Planning for a Data Base; Systems to Speed Up and Improve Data Output and Dissemination; New Developments for Data Base Long Range Planning; Techniques in Data Base Administration; and Computer and Communications Security for Data Processing.

A complete program can be obtained from Clapp & Poliak, Inc., 245 Park Ave., New York, NY 10017.

REGISTRATION INFORMATION

A variety of registration fees are available: attendance for the four full days, Oct. 16-19, is priced at \$225. One day at the conference is \$80 and a half day is \$45. If you're only attending the exhibits, the registration fee is \$5. Persons receiving tickets from exhibitors will be charged \$1.

Among the 70 first-time exhibitors in this year's conference are: IBM's Data Processing Div.; Dictaphone Corp.; A. B. Dick; Texas Instruments; Automatic Data Processing; Consolidated Computers International; Infoton; Compugraphics; Jacquard Systems; Quantor Corp.; DatagraphiX; and Nanodata. Hewlett-Packard Corp., which hasn't exhibited at NCC for two years, will exhibit at Info 78. NCR Corp., which last year had a 300 ft. booth, this year has expanded to 1,500 ft.

Wolcott, who expects a turnout of about 15,000 to the show, but would be happy with 14,000, says the huge turnout of exhibitors is due in part to good economic times in the industry, but also to the fact that Info has come of age. "They recognize us now as a viable exposition with an attendance made up of the right people," he said.

Clapp & Poliak is a huge international show management firm. While Info 78 is small compared with its Plant Engineering Show with 800 exhibitors and its Design Engineering show with about 500 exhibitors, Info is growing and for the first time this year will be running in the black. But Wolcott says all anticipated profits will be poured into attendance promotion. "It's growing, but it's far from gaining the stature we have in mind," Wolcott said.

The exposition will be held on the street level floor of McCormick Place, and two other shows are being held at the same time on the lower level—an industrial construction show and a premiums show—which Wolcott thinks might also be visited by attendees. *

CIRCLE 187 ON READER CARD

Our new line of 80-column, dot-matrix line printers - the Anadex DP-8000 Series - combines high print quality and low cost with the highest available OBI's rate for a printer.

Looking for Performance?

All models feature a precision engineered, continuous duty printer mechanism that can print the equivalent of 96 ASCII characters per second normally, or 84 PPM at a higher resolution. And the built-in internal FIFO buffer storage (optional) allows characters to print out as fast as they arrive at the printer system interface.

A 9 x 7 character font can provide virtually half the resolution for a given printer system quality.

For flexible interfacing, the DP-8000s available with either a standard or optional RS-232C, with selectable EIA/DTE rates up

to 9600 BAUD. Current Loop or Parallel Bit Serial Operation.

Printed on standard weight paper is guaranteed by Anadex to be the printer of choice for programable and other forms control, and other business-related tasks.

Looking for Economy?

For outstanding value, the DP-8000 Series provides the most economical choice for high quality, programable and other forms control. It's the Over Printer's Choice for quality and price.

Looking for Low Cost?

The best news is the price. An Anadex DP-8000, available in standard or optional OBI/optional rates.

Once you've examined the superior value and seen the printer in operation, we think you'll agree: "Printer's Choice/Performance never looked better."

For complete details, contact DP-8000 Marketing Dept., Anadex, Inc., 9825 DeSoto Ave., Chatsworth, CA 91311. Phone: (818) 995-3010; Telex: 910-494-2761.

Printer
Price/Performance
never looked
better.

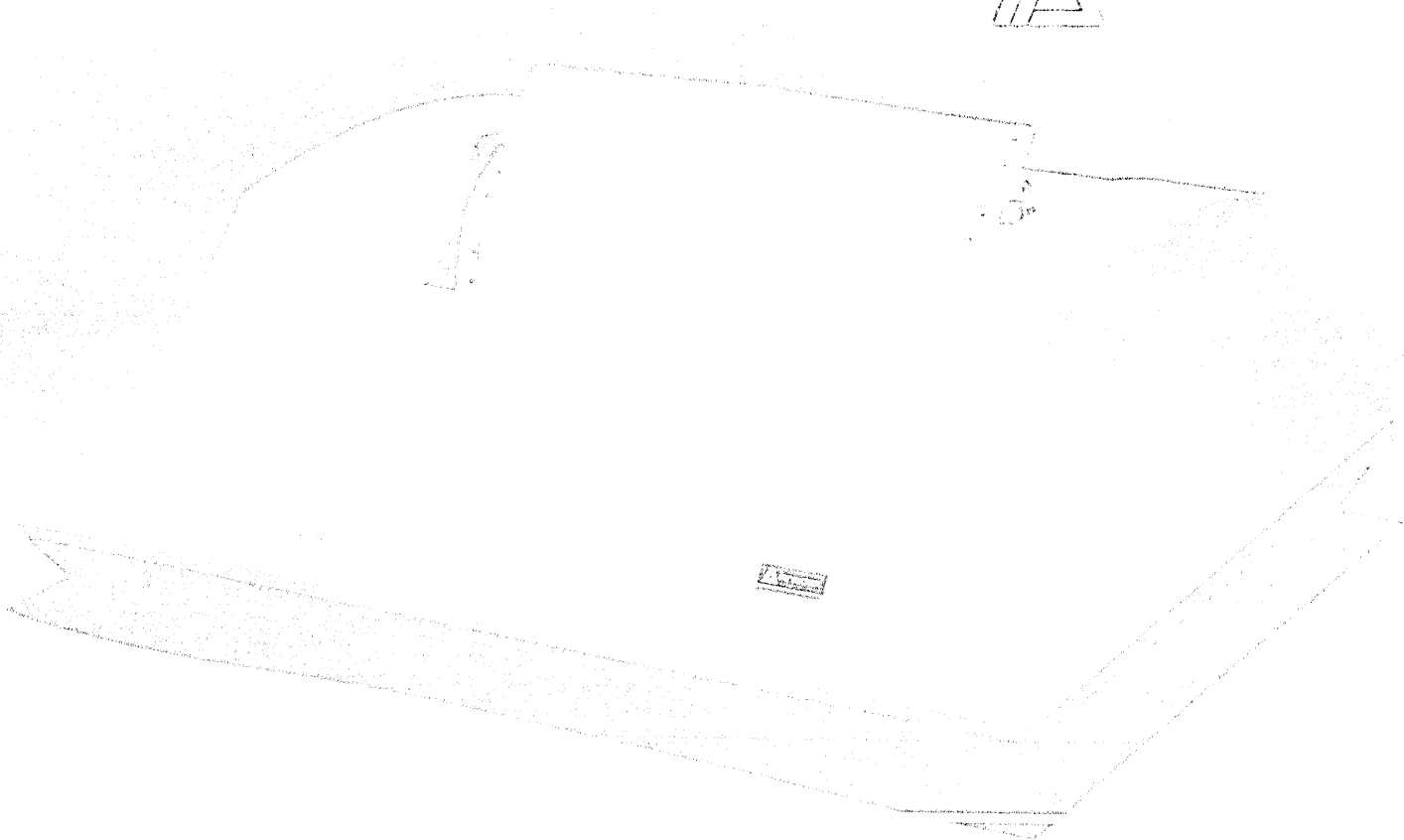



Family planning allows our computer systems to grow as fast as you do.

When we designed our 990 Computer Family, we put a lot of thought into it. A lot of technology, too.

Our planning paid off. Today, we have large disk-based, multi-user, multi-language commercial systems, like our DS990 System. Its powerful DX10 software has over 170 system commands built in, to make light work of your office workload. Interactive or batch. We also have smaller standalone diskette-based systems, like our FS990 System. And they're all engineered to communicate with each other and to grow as your needs grow.

From the first, our plans called for software that can expand as your business does. So, when we engineered our TMS 9900 Microprocessor, we made it the first to use software that's upward-compatible with our entire line of 990 computers. Compatibility that protects your software investment.

Built into every 990 computer system is over 30

years of experience in the electronics industry, and the technical expertise and support of our worldwide organization of factory-trained sales and service engineers, backed by TI-CARE*, our computer-automated field service dispatching and information system.

With the 990 Computer Family, you are assured of the lowest possible cost of ownership. Low purchase, maintenance and service costs. And reliable operation.

To see how our planning can keep pace with your growth, today and tomorrow, call your nearest TI sales office, or write Texas Instruments Incorporated, P.O. Box 1444, M/S 7784 Houston, Texas 77001.

TEXAS INSTRUMENTS
INCORPORATED



*Service Mark of Texas Instruments
Copyright © 1978, Texas Instruments Incorporated

CIRCLE 32 ON READER CARD

TEXAS INSTRUMENTS.

We put computing within everyone's reach.

THE INTERNATIONAL SERVICES INDUSTRY IN CONFLICT

by Ralph Emmett, European Editor

The little micro cast a giant shadow over the first-ever World Computing Services Industry conference held in Barcelona, Spain. It emerged as a tool to divide the 600-plus attendees from all sectors of the global services community into two warring camps. It stood throughout the three day event as an insurmountable barrier to the assembly's quest for a common language and aim.

And finally, it opened the door for control of this fledgling industry to be taken out of the hands of the service companies that have so painstakingly built it up.

The keynote speaker and head of the U.S. service bureau ADP, Frank Lautenberg, talked of "doom-sayers" who claim that the services industry is just a "coincidence of circumstance" and a "bridge" between old and expensive computer resources and new low cost devices. "Are we to be obsoleted by a massive outpouring of devices dedicated to services required by our customers? . . . Is this first world conference a prelude or a finale?" he asked.

Lautenberg's answer was: "Probably not a finale." He said that the outcome depends not on the forces of technology, but on the skills, resourcefulness, and sense of opportunity of the services community.

His theme—which set the tone for the whole event—was that the role of technology is overemphasized. "What counts is service at the right price," he stressed. Other service bureau pundits took up this banner by claiming that some software houses left the end user "out" in their desire to be "engaged" with the manufacturers.

This attack led to charges from software company representatives that Lautenberg "and his kind" were afraid of

the microprocessor suppliers.

Most vocal of these delegates was Alex d'Agapeyeff, head of the U.K.-based software group, CAP/PPP, who thrust a four-inch wafer of silicon under the noses of the packed assembly and told them that the market for it and its offspring in desktop computers would "dwarf" anything that had gone before. He warned his colleagues of the dangers of being complacent about the micro:

"Instead of peddling time on expensive and obsolete machines the service industry should be learning how to exploit the opportunities provided by the micro," he said.

A contingent of Swedish service bureau representatives talked of the strong competition between the software and service bureau industries. L.H. Schwieler from Datema AB, Sweden, said the service bureau industry had always welcomed new hardware developments in the past. Why should it see them as a threat now?

Schwieler said that service bureaus had looked with alarm at the growth in tailored on-site minis and micros offered on a turnkey basis by the software houses. In an effort to compete,

ADP and others are now offering stand-alone systems at the user's site. But users are getting a "wrong understanding of the situation because we price our minis and micros in the software house way," he said.

Schwieler went on to say that he couldn't understand why bureaus had been lulled into talking about hardware costs at all because they are "low" and "not really relevant in our business method of offering a complete service."

Richard Crandall, simultaneously ADAPSO and COMSHARE president, supported this by saying that only 15% to 25% of the revenues of computer service companies were tied up in hardware costs, according to a recent ADAPSO survey. He noted that in some packaged applications, such as income tax preparation, hardware costs amounted to only 8% of total revenues. "Furthermore," he added, "the central processor itself typically represents only 25% to 33% of the cost of the total computer."

"Thus, major changes in main-frame price/performance resulting from the introduction of LSI circuits would only impact less than one-fourth of 25% of a computer service firm's operating



Delegates from 25 countries—including India, Israel, Japan, New Zealand, Australia, and South Africa as well as Europe and the U.S.—met to find a common ground, but had great difficulty coming to agreement.

Successful service firms are growing at twice the rate of leading mainframers.

performance," Crandall said.

Bearing these facts in mind the Swedish bureau contingent stressed there was no reason for not using the "standard service bureau method" of charging per transaction—independent of whether the hardware is a micro, mini, large scale computer, or any combination.

They envisioned the growth of the "dp center" approach to combine the best elements of both service bureau and software house approaches in a more nearly "total solution." In this scenario application languages would reside on large scale computers in these centers. Centralized development for a large number of minis and micros was described as the only administrative way of keeping maintenance costs down.

BOOM TIME FOR SERVICES

Having noted the impressive growth of the services industry to its present

\$13 billion market and 500,000-person workforce level, Lautenberg asked his audience: "We have the critical mass needed to assure our continuity in some form. What will that form be?"

Figures offered by Lautenberg showed that successful computer service firms are growing at twice the rate of

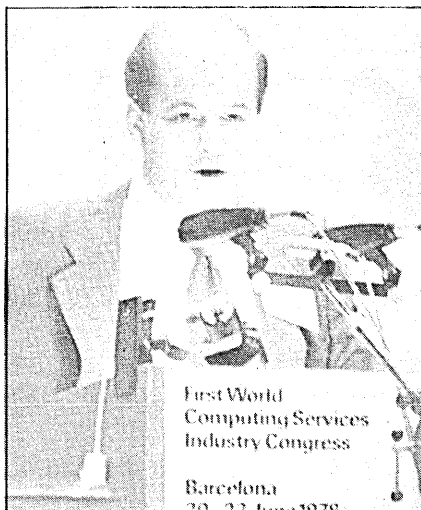

Alex d'Agapeyeff: "Instead of peddling time on obsolete machines, the industry should learn how to exploit the micro."

leading mainframers. Much of this growth comes from the private data network resource concept which "bleeds" traffic (and hence revenue) from the carriers' public facilities.

Lautenberg claimed that the revenues for a group of 10 publicly traded, independent, U.S.-based com-

puter service companies had grown at an average rate of 26% during the last five years. He claimed that net profit after tax for the same 10 concerns had grown at an even more spectacular 37% a year. During the same time span the six largest U.S. mainframe manufacturers increased revenues an average of only 13% and after tax income 15%. Further, New York analysts say that the mainframe business cannot expect to grow at more than 11% to 12% per annum over the next five years, whereas services should grow at some 20% or so.

"Those who successfully package a manufactured item and add value to it can grow at a rate in excess of that for the naked item," the ADP chief explained. He cited the example of the airlines, which he said had grown almost 2.5 times faster than aircraft manufacturers.

These forecasts brought a smile to the faces of this unusual Barcelona gathering of entrepreneurs, opportunists, and proponents of the "value-added world" slogan. But each of the faces from the 25 countries—including places as far flung as India, Israel, Japan, New Zealand, Australia, and South Africa—expressed a different angle, while Lautenberg was calling for the need for a "common mission" as an aid to survival.

TERMINALS FROM TRANSNET

**PURCHASE
12-24 MONTH FULL OWNERSHIP PLAN
36 MONTH LEASE PLAN**

DESCRIPTION	PURCHASE PRICE	PER MONTH		
		12 MOS.	24 MOS.	36 MOS.
DECwriter II	\$1,495	\$145	\$ 75	\$ 52
DECwriter III	2,695	257	137	95
DECprinter I	1,795	172	92	63
VT52 DECscope	1,695	162	85	59
VT100 DECscope	1,695	162	85	59
VT55 DECgraphic CRT	2,395	229	122	84
ADM 3A CRT	875	84	45	30
HAZELTINE 1400 CRT ..	845	81	43	30
HAZELTINE 1500 CRT ..	1,195	115	61	42
TI 745 Portable	1,875	175	94	65
TI 765 Bubble Mem. ...	2,995	285	152	99
TI 810 RO Printer	1,895	181	97	66
TI 820 KSR Terminal ..	2,395	229	122	84
Data Products 2230 ...	7,900	725	395	275
QUME, Ltr. Qual. KSR ..	3,195	306	163	112
QUME, Ltr. Qual. RO ..	2,795	268	143	98
DATAMATE Mini floppy	1,750	167	89	61

FULL OWNERSHIP AFTER 12 OR 24 MONTHS
10% PURCHASE OPTION AFTER 36 MONTHS

ACCESSORIES AND PERIPHERAL EQUIPMENT

ACOUSTIC COUPLERS • MODEMS • THERMAL PAPER RIBBONS • INTERFACE MODULES • FLOPPY DISK UNITS

PROMPT DELIVERY • EFFICIENT SERVICE



TRANSNET CORPORATION

2005 ROUTE 22, UNION, N.J. 07083

201-688-7800

PORTABLE KEY PUNCHES

for remote data collection or encoding of access control, I.D. and credit cards

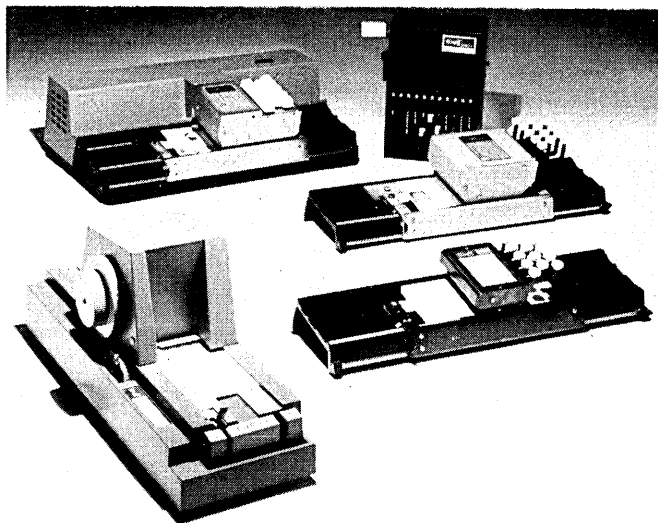

For punching machine readable holes in 80 column cards, 22 column cards, 51 column cards, card sets, credit cards and plastic I.D. badges. Standard manual and electric models or special configurations in OEM quantities. Send for brochure giving details.

**Electro
Mechanics**

Electro Mechanics Division, Wright Line Inc., 160 Gold Star Blvd., Worcester, Mass 01606

CIRCLE 200 ON READER CARD

There's more to paper media than meets the eye

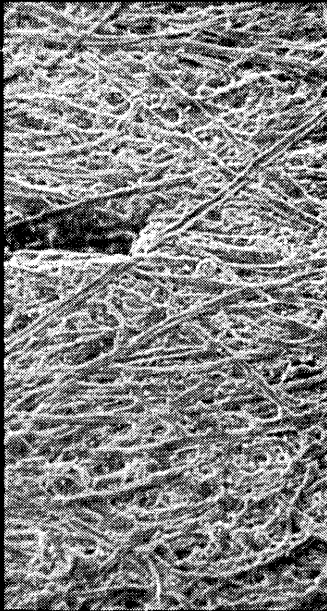

50X

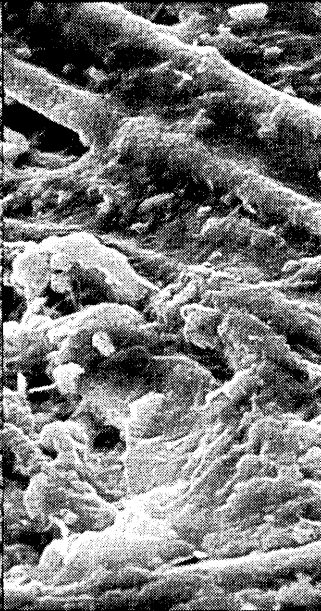

500X

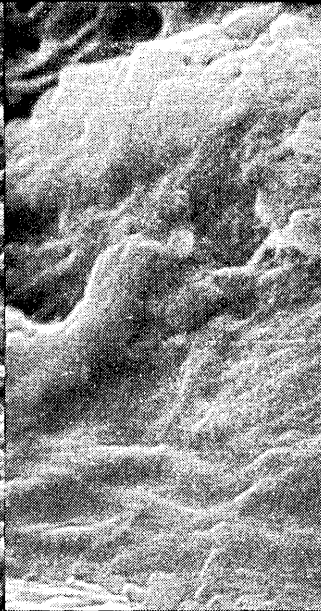

5000X

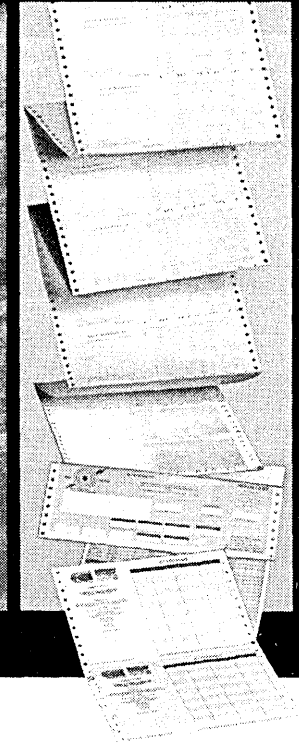

This close look at a business form shows details not apparent to the naked eye. And while forms design normally does not require the high technology of a scanning electron microscope, the process of designing and manufacturing business forms is a complex and demanding task.

Attention to detail is critical to quality. And quality in business forms is critical to keeping your operations running smoothly and efficiently. No output printer operating at today's speeds, no OCR or MICR equipment can do its best with forms that are poorly designed, printed or perforated.

We recognize this because we are computer specialists. We understand the importance of carefully designed business forms. And we can bring this expertise to bear on the success of your business. Whatever your needs—continuous forms, unit sets, OCR or MICR—we're experienced problem-solvers when it comes to paper media.

Our people are professionals in data processing, system analysis and the design of business forms. We're ready to help you simplify paper-

work, analyze your forms requirements and provide solutions to handle your unique needs. Give us a call today. 612/853-6853. Or send us the coupon.

Mr. W. B. Rodemann, Vice President
Business Products Marketing
Control Data Corporation
P.O. Box 1980
Twin Cities Airport, MN 55111

D-98

Send me samples and information on:

- Custom Forms Design OCR Forms
 Stock Continuous Forms MICR Forms

Name _____ Title _____

Company _____ Phone _____

Address _____

City _____ State _____ Zip _____



More than a computer company



**Edson D. de Castro, President,
Data General Corporation.**

“WE MAKE COMPUTERS THAT MAKE SENSE FOR BUSINESS. AND WE’RE READY TO PROVE IT AGAIN.”

In the last 10 years, we’ve sold tens of thousands of computers that make sense to business people. Today, Data General begins a new era in commercial computing. With the introduction of new commercial software capabilities for our ECLIPSE® series. Which make our ECLIPSE data systems even more cost-effective, expandable, flexible and easy to use, especially in distributed processing.

This new commercial software combined with our proven multiprogramming capability allows our ECLIPSE data systems to use every one of our data processing languages simultaneously. Which means our systems can use COBOL, PL/I, RPG II and all of our other languages in support of your day-to-day operations by running on-line, transaction-driven and time-sharing tasks, as well as summary reporting. At the same time, the system can schedule other batch processing, along with independent new application development.

The bottom line is that it has taken Data General to make this giant computer capability affordable. An ECLIPSE data system with our new commercial multiprogramming capabilities costs far less than similar systems.

If you want a computer system that helps solve your DP manager’s daily problems of productivity and flexibility, it makes more sense than ever to talk to us. The coupon below will bring you the proof: our new brochure for business people or, if you prefer, a personal visit by a representative.

 **Data General**
We make computers that make sense.

Name	Title	Company	Tel. No.	
Address	City	State	Zip	DM978
Data General Corporation, Westboro, MA 01581, (617) 366-8911. Data General (Canada) Ltd., Ontario. Data General Europe, 61 rue de Courcelles, Paris, France, 766.51.78. Data General Australia, (03) 89-0633. Data General Ltda., Sao Paulo, Brazil, 543-0138. Data General Middle East, Athens, Greece, 952-0557. ECLIPSE is a registered trademark of Data General Corporation. © Data General Corporation, 1978.				



"HANDS-ON" PROJECT MANAGEMENT

EZPERT® Project Graphics System puts visibility into your project planning, scheduling, monitoring and control...when you need it, where you need it, and how you need it.

If you're involved with project management you know how critical it is to see how a total project "fits" together, and how interdependent activities affect its day-to-day progress.

Now EZPERT puts that visibility into your hands—like no other system can—with *Time Scaled Networks, Gantt Barcharts and Cost/Manpower Graphs*...produced and updated automatically.

Fast and accurate.

EZPERT can give you totally revised and virtually error-free graphics within hours of a project change. So management decisions are always based on current and correct information.

Easy to use.

If you're currently using project management techniques, you're already doing most of the work. EZPERT uses the same basic information to automatically produce project graphics on an electrostatic, pen or microfilm plotter.

Join the group.

Leading manufacturing and aerospace companies, engineering/construction contractors, utilities, financial institutions and government agencies are already using EZPERT. Maybe you should be too. Call us for more information—today!

Overseas Sales Representative inquiries invited.



SYSTONETICS, INC.

600 N. Euclid Street, Anaheim, California 92801
(714) 778-1600

Visit us at INFO '78 - Booth #325

Tab's Mini-Handlers make Man-Handlers obsolete.



Tab's New Mini-Burster and Two-Part Decollator Consolidate Big Forms Handling Features into Two, Versatile, Table-Top Components.

Now any small or medium size business can afford big forms handling speed and efficiency with the addition of Tab's 2444 Mini-Burster and 2422 Two-Part Decollator. Tab's Mini-Handlers take the mess and time consuming labor out of forms handling and provide you with ready-to-use data, fast!

TAB's New Model 2444 Mini-Burster Delivers Performance for Under \$1000!

The Mini-Burster is innovatively designed for simplicity, versatility, and performance, when handling single light-weight forms, multi-part forms, card stock, mailers, or checks of any size. The 2444 features a slide safety cover with interlock switch, variable speeds of up to 200 feet/minute, and a jam detector that stops burster activity should forms not stack properly.

Your Forms Processing Will Be Easy as Duck Soup with the Addition of Tab's 2422 Two-Part Decollator.

When you combine Tab's 2422 Table-Top Decollator with the versatility of the 2444 Mini-Burster, you have all the necessary components for swift, efficient printout handling and processing. The 2422 can decollate stacks of forms up to 8" high at speeds up to 450 feet per minute. For complete information, contact your local Tab representative or write Tab Products Company, 2690 Hanover Street, Palo Alto, California 94303.



TAB
PRODUCTS CO

THE HEAVYWEIGHT CONTENDERS

The British Post Office also looked hard at the "value-added" philosophy in the light of its own manufactured items: its millions of dollars worth of buried telephone cable . . . "gold in the ground" . . . and came up with Viewdata. "Viewdata" has now become a generic term for a domestic service in the home or office whereby vast computer data bases are spewed on-line via the telephone network to ordinary (if slightly converted) tv sets. The U.S. Post Office has sold the software for its system, which it calls Prestel, to both the German and Dutch Post, Telephone and Telegraph agencies (PTT's) and other sales to European telecommunication authorities are in the pipe. Later this year the British PTT will demonstrate how the system can be extended to embrace minis, micros, and other small business systems by the distribution of programs.

In the immediate future the first tentative links between these Viewdata networks will take place and the whole will give what d'Agapeyeff described as a "tremendous thrust for office automation." But as the PTT's can enter the value-added services business at will with their existing network monopoly, the

whole will also act as a tremendous freeze-out to the (currently) dominant U.S.-based network service bureau in Europe which try to offer competitive services.

Many delegates worried that the communications carriers, with their protected status, would force out many services suppliers (and that those which were not trampled by the communications monopolies would be run over by IBM). Among them were the Control Data Corp. representatives, who said that unlike the PTT's, "who are subsidized and can afford to run at a loss if necessary," CDC's shareholders didn't like red balance sheets.

Another fear among the Americans is that a linked Viewdata setup on a Pan-European (or even international) scale would act as a magnet to lure away their life-blood data base and information providers who would see greater revenue opportunities with the PTT's.

The conference chairman, Alan Benjamin, director-general of the U.K. Computing Services Assn. (CSA), was referring directly to these PTT's moves when he warned delegates that control of the services sector "could be taken out of our hands." Benjamin has been at the center of a fierce lobby to get the union

of PTT's (CEPT) to define its communications monopoly in clear terms and ensure that its involvement in services is up-front and allows service companies to compete on equal terms.

Another familiar complaint, this time from one official from the Spanish packet-switched network, CTNE, was a clear delineation of where dp ends and data communications begins. The dp monopoly and the telecommunications monopoly (in the form of European PTT's) have already met head-on on the question of data network standards—and so far IBM has given way. Having forced IBM to toe the line on its land network standard, X. 25, the PTT's—particularly the French—are expecting IBM to attack again, this time from the sky via satellites. At stake is control of the automated office of tomorrow—the largest potential market for services.

As this gigantic confrontation begins to take shape, the Spanish arena for its early expression was perhaps appropriate. More than a few of the 600-plus delegates were beginning to visualize the PTT's playing matador to the IBM bull.

Whether the late-June Barcelona meeting was "prelude" or "finale," it's likely that the next time the curtain goes up that contest will be on center stage. *

Introducing the Latest Word in Bursters and Decollators

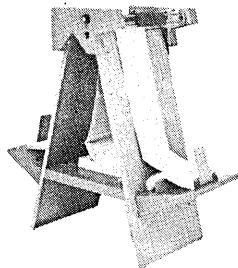

Precision engineered to reduce noise, vibration and paper debris pollution. Special features include new roller design, unique bearing surfaces and paper guides to assure reliable performance with minimal maintenance. This new line of forms handling equipment is the most advanced in the industry and can be easily operated with nominal instruction. Prices for this new breed of bursters and decollators are very competitive with conventional models. Please write or call for more information.

Tion makes it better for you.

TION EQUIPMENT COMPANY
8133 Capwell Drive
Oakland, California 94621
(415) 638-8588

CIRCLE 198 ON READER CARD

COMPUTER DEALERS WANTED

Billings Computer Corporation announces the opening of a limited number of dealerships across the country.

Dealers are given intensive technical training and comprehensive marketing support. Profit margins are excellent. In addition, Billings offers sizable quantity rebates and substantial equipment discounts.

Billings' main product line is a sophisticated, stand-alone business accounting system for small businesses. The complete hardware-software system is micro-processor based and includes 12 interacting programs for comprehensive financial and management reporting.

The program and the product are superb.

Only those with technical expertise, strong financial background, and professional marketing capabilities will be considered.

If interested, write or call collect:

Billings Computer Corporation
2000 East Billings Avenue
Provo, Utah 84601
(801)375-0000.



CIRCLE 223 ON READER CARD

The Age of Array Processing Is Here

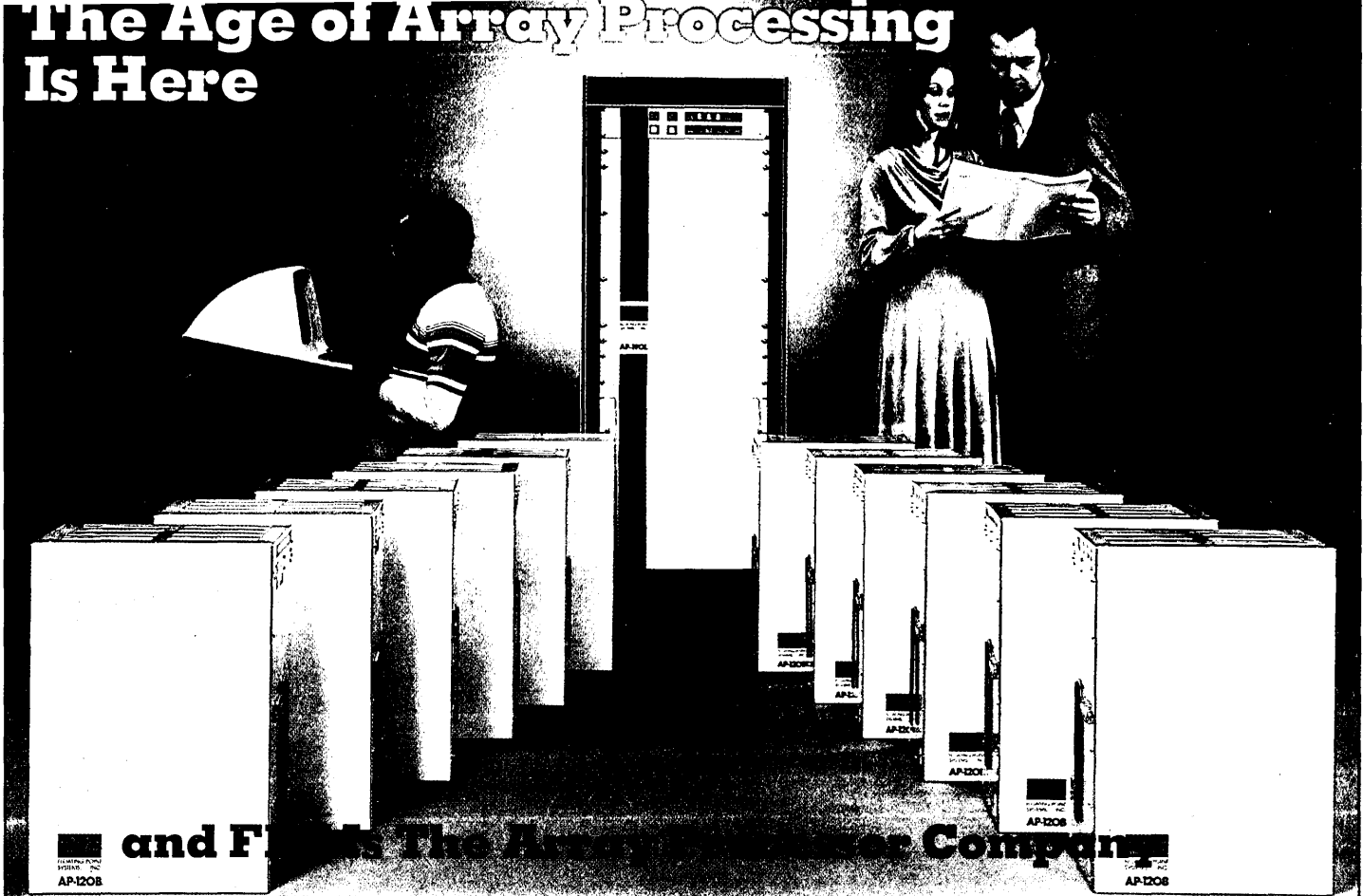

and Floats The Array Processor Company

**The AP-120B
ARRAY PROCESSOR COMPUTER**
Interfaces to all popular minicomputers . . . a typical AP-120B complete is less than \$50K.

**The AP-190L
ARRAY PROCESSOR COMPUTER**
Interfaces to IBM 360/370, UNIVAC 1100, Sigma 5-9, and DEC System 10 . . . a typical AP-190L System is less than \$97K.

Simulation: Mechanical Systems, Flight, Theoretical Physics & Chemistry, Electric Power Distribution • Image Processing: Satellite Imagery, X-Ray Tomography & Ultrasonics • Graphic Research • Finite Element Analysis • Meteorology • Signal Processing: Speech, Vibration Analysis, Geophysical and Seismological.

More than 500 FPS Array Processor computers are in use worldwide, providing their users with the computational power of large, mega-dollar scientific computers at greater reliability, greater applicability, easier programmability, and at a small fraction of the cost.

A typical minicomputer/FPS Array Processor system (such as a PDP 11/34 and AP-120B) provides a computational throughput

for scientific and signal processing algorithms that is on the order of **two hundred times greater** than the throughput of the mini alone.

A large computer/FPS Array Processor system allows heavy data processing, which would severely load the host CPU, to be **off-loaded to the AP-190L for efficient processing** while the host CPU is utilized for tasks more appropriate to its architecture and operating system.

The unique, efficient instruction set and complementary architecture of FPS Array Processor computers are **specifically designed to accommodate the vector and matrix algorithms** for scientific data processing. High processing speeds result from the **seven independent data paths** that move operands synchronously to and from the **38-bit floating-point arithmetic units, accumulators, and multiple memories**. This inherent simplicity allows FPS Array Processors to be readily simulated on the host or front-end computers for program development. It allows FPS to provide you with a large volume **Scientific Math Library** (more than 200 functions) and additional volumes for **Signal Processing and other special operations**. And it allows you to **program FPS Array Processors** so you can create your own special, unique, or proprietary functions.

FPS Array Processor computers offer high reliability (much more than your present computer) and compactness (only slightly larger than minicomputers). They are found in research, shipboard, airborne, and mobile installations, as well as computer rooms throughout the world.

FAST
167 nanosecond multiply/add
The following algorithms are memory to memory
2.7ms 1024 pt real FFT
26.1ms 8192 pt real FFT
1.55s 512 x 512 real 2D FFT
10.2ms 20 x 20 matrix inverse

EASY PROGRAMMING
The power of FPS Array Processors is easily called through FORTRAN subroutines resident in the host or front-end minicomputer. A Vector Function Chainer permits routines to be chained together for a single call, reducing host overhead. Extensive documentation and a simulator/debugger help you create new routines.

HIGH CAPACITY
Data memory to 512K words (2-million bytes)
PRECISION
38-bit floating point arithmetic

FPS can bring new power to your computer system. Find out how FPS Array Processor technology can benefit your application. For more information and an FPS Array Processor brochure, **use the reader response number or coupon below**. For immediate consultation, **contact Floating Point Systems directly**.



CALL TOLL FREE 800-547-9677
P.O. Box 23489, Portland, OR 97223
TLX: 360470 FLOATPOINT PTL
In Europe & UK: Floating Point Systems, SA Ltd.
7 Rue du Marche, 1204 Geneve, Switzerland
022-280453, TLX: 28870 FPSE CH

Floating Point Systems, Inc.

FPS Sales and Service Worldwide: Boston, Chicago, Dallas, Detroit, Houston, Huntsville, Los Angeles, New York, Orlando, Ottawa, Philadelphia, Phoenix, Portland, San Francisco, Washington, D.C. International offices: Geneva, London, Munich, Paris, Tel Aviv (Easttronix, Ltd.), Tokyo (Hakuto Co. Ltd.)

CIRCLE 61 ON READER CARD

I have an immediate need. Please have a technical consultant contact me.

Please send me an FPS Array Processor brochure.

Name _____ Title _____

Company _____ Phone _____

Address _____

City _____ State _____ Zip _____

My Computer System is _____ My application is _____

DATAMATION 9/78

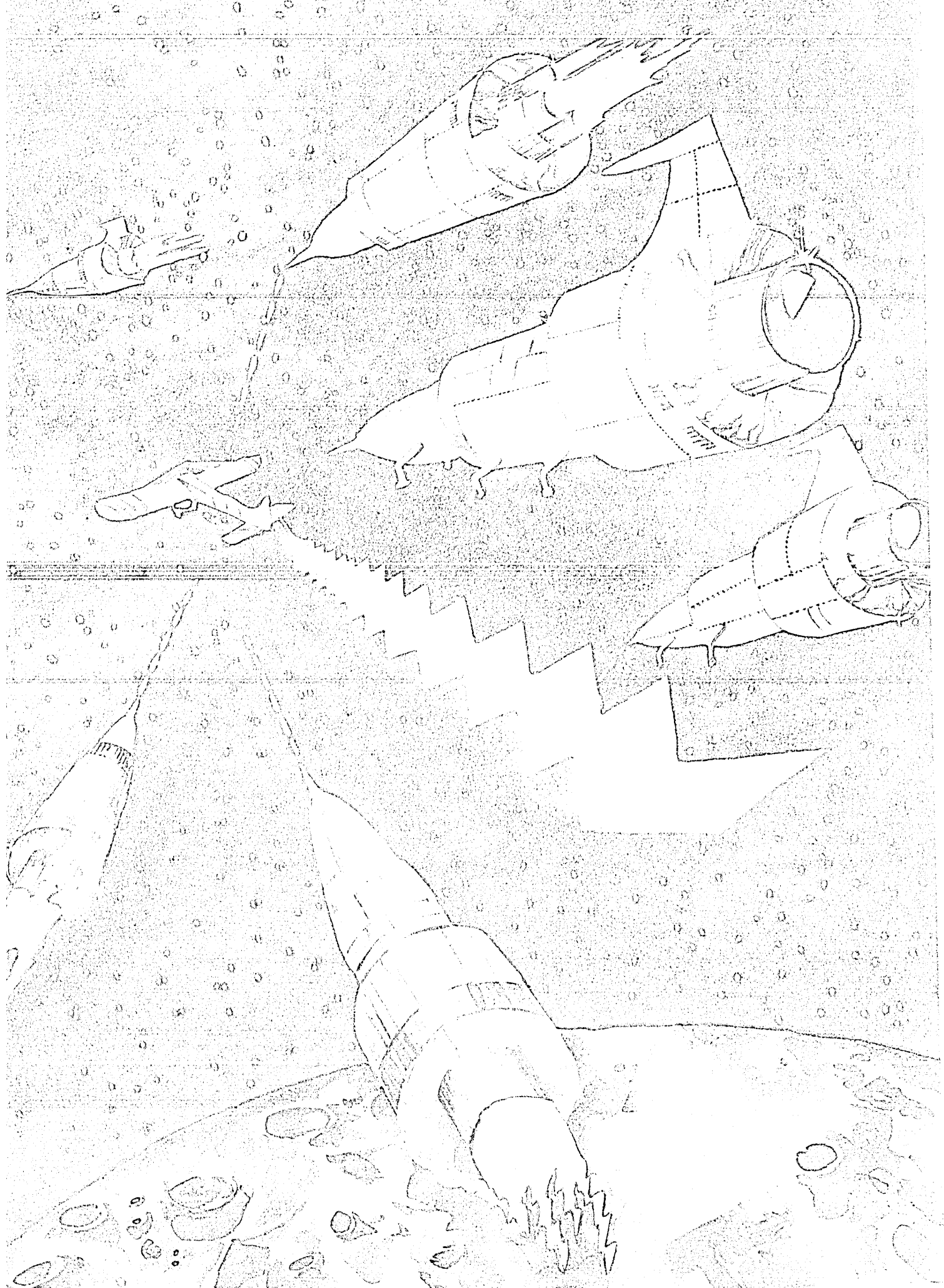

Central site printing will be reduced significantly by 1982, and will virtually disappear by 1988. Remote sites will drop printers too, where they can.

DON'T BET ON PAPER OUTPUT

by Tim Tyler

Since their birth in the 1940s, computer systems have produced ever increasing quantities of paper output, and it is commonly assumed that the trend will continue. This view is supported by many forecasts based on widely accepted market research techniques. However, such techniques are not appropriate for predicting the impact of new technology, and those who rely on them are forever exposed to unpleasant surprises.

The use of punch cards provides an interesting example of how forecasts go wrong. Fig. 1 (see page 268) plots worldwide tab card shipments from 1965 through 1975. From 1965 through 1969, shipments rose steadily and prompted correlations to be established with the installed computer base, the number of installed keypunches, the volume of business transactions, and the gross national product. Production of nearly 700,000 tons of card stock was predicted for 1975.

Unfortunately (for the card manufacturers anyway), the correlations all turned out to be nonsense. Shipments peaked at 559,000 tons in 1969 and dropped to a plateau around 500,000 tons in the early '70s—where they remained in 1975, 30% below the earlier prediction.

The projections were updated in 1975 by several leading market research firms. It was predicted there would be gradual erosion in the punch card market of 3.3% per year through 1980. What really happened was that shipments dropped 23.6% that year, and management of paper companies got another of those unpleasant surprises.

Today's projections for the domestic use of continuous forms for computer output say that forms shipments will increase in value from \$1.2 billion in 1976 to \$3.7 billion in 1988. However, computer and communica-

tions technologies are currently making the substitution of electronic media for paper not only possible, but necessary, just as they did for punch cards. The potential significance of this change is not understood by either the general public or by those closely associated with computer/communications technology. Those big projections for 1988 are dead wrong. To appreciate why, it is necessary to look closely at dp spending.

A relatively stable relationship has been established between personnel costs and other data processing costs. It is roughly as follows:

Personnel costs	45%
Hardware, services & supplies	55%

For the expenses over which dp management has direct control, the ratio stated above has been surprisingly consistent. Further, the dynamics of dp budgets have been (and will continue to be) within the two broad areas and not between them.

An analysis of hardware, communications and supplies budgets (among large dp users) reveals the trends and projections illustrated in Table 1.

The cost distributions are not intended to be precise (although they are within published ranges). They are presented to describe cost trends from the viewpoint of data processing management, and their specific purpose is to illustrate dp management's priorities. The following general statements can be made about the budget table (see reference numbers on the table):

1. Central processors are becoming a relatively less important expense.
2. Mass storage (disk, tape, etc.) at central (or host) sites will remain relatively stable as a percentage of hardware budgets, but this does not include secondary storage associated with minicomputer and intelligent terminal sys-

tems. (Storage is growing more rapidly than any other item but it is migrating out from the central site as distributed processing is implemented.)

3. Minicomputers will continue to assume increasing importance but the actual processors will sell for "microprocessor prices." The relative increase is due primarily to storage associated with the systems.

4. Data entry equipment, unit record equipment, and printers will either disappear or lose their identity by 1988. Unit record installations had virtually disappeared by 1977. Key-punches and standalone data entry systems will be replaced by multifunction terminals by 1988 as data is captured at the point of transaction. Printers will not be primarily associated with central sites but will have become associated with minicomputer or intelligent terminal systems.

5. Terminals and communications hardware will continue to have more substantial processing capability. This category will represent the largest single item in the budget by 1988. Practically all hardcopy output will be generated at this level of the processing hierarchy.

6. Supplies are assumed to remain relatively constant as a percentage of budget in order to determine what the impact will be from the point of view of data processing users.

7. Data communications will continue to grow as a percentage of total data processing expenditures.

The following is the rationale for what has occurred and is projected to occur with dp budgets:

In 1965 the data processing function was centralized within major organizational entities. Centralized computer hardware represented nearly 75% of the budget (other than personnel). It is easy to understand the priority given to new hardware and its associated systems software by dp managers.

There are expenses and problems to "distribute".

Alternate data entry equipment became available in the mid-1960s (key-to-tape). Since a significant portion of the personnel budget was associated with data entry (and personnel costs were increasing), this problem was also addressed, with the result that punch card usage peaked in 1969. The expense of data entry equipment was contained and it shrank to 11% of the dp budget by 1977.

The shift to "on-line" systems was primarily because of dissatisfaction with service from centralized computer departments. After multiprogramming operating systems were developed, the primary systems response bottleneck became printing and distribution of output. Users were willing to pay for better response and by 1977 centralized computer facilities represented less than 50% of the dp budget (again excluding personnel).

This distribution of costs within dp budgets has also resulted in a complex pattern of expense distribution between centralized dp budgets and those of end users. Hardware, communications, supplies, and personnel expenses are not budgeted in a uniform manner. This has resulted in less centralized control of budgets and substantial confusion. This trend will continue as distributed processing extends to smaller organizational entities and to the office environment.

GOING DISTRIBUTED

Regardless of how threatened data processing management feels by decentralization of control, there are certain expenses and problems they would as soon "distribute" to the end users:

- high response applications development
- ad hoc reporting requirements
- data entry functions
- physical preparation and distribution of output
- responsibility for sensitive data bases

Therefore, contrary to popular opinion, informed data processing management has several reasons for wanting to see certain responsibilities distributed. Distributed processing also obscures the cost of data processing expense, and this can be a definite advantage since general management has become somewhat disenchanted with dp achievements to date.

To understand the dp manager's point of view, it is necessary to examine how the costs of data processing are recovered from end users.

Normally the facilities which are

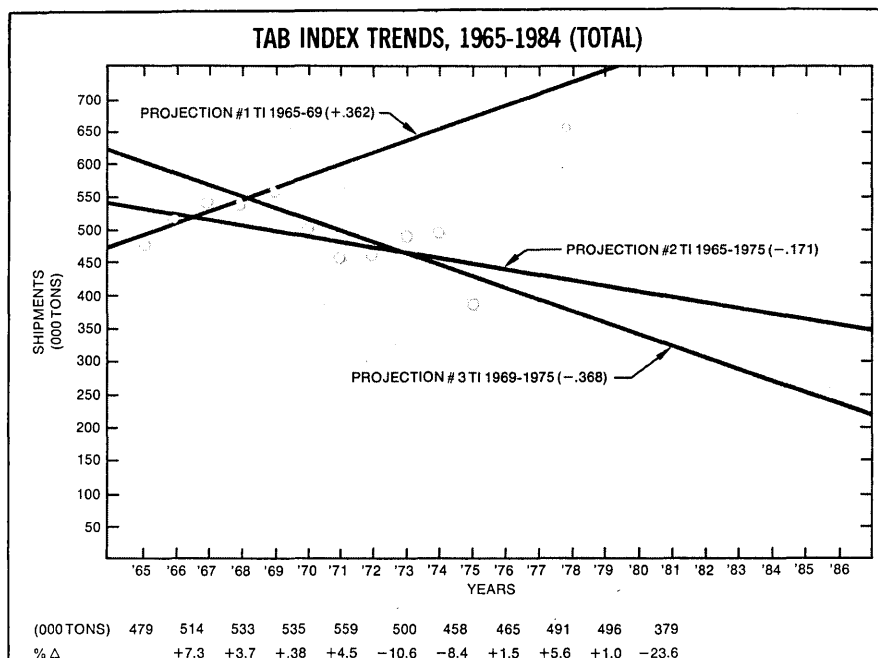

Fig. 1. The punch card industry is an excellent example of projections which have gone sour because of new developments in computers and data communications. Even after a huge, unexpected drop in sales in 1970 and 1971, the industry thought it recognized a plateau in 1972, 1973, and 1974. Actual sales for 1975 fell off the plots again.

HARDWARE, COMMUNICATIONS AND SUPPLIES BUDGET

	1965	1977	1982	1988
1. Central processors & main memory	41%	23%	20%	15%
2. Peripherals & mass storage	32%	20%	20%	20%
3. Minicomputer systems	—	7%	12%	15%
4. Data entry, unit record & printers	17%	11%	5%	—
5. Terminals & communications hardware	—	19%	21%	25%
6. Supplies (paper & magnetic media)	10%	10%	10%	10%
7. Data communications services	—	10%	12%	15%
	100%	100%	100%	100%

Table 1. By now, the falling budgetary importance of central processors and main memory is no surprise. Nor is the rising importance of minicomputers. What may come as a shock is how quickly printers are expected to follow the path of EAM equipment. Note that the Supplies percentage has been **assumed** to remain constant in order to isolate what is happening in other categories.

shared by multiple users are accounted for by use of a billing algorithm which attempts to allocate cost based on resource utilization. Algorithms vary significantly but normally account for cpu cycles, I/O activity, priorities, etc. Supplies and personnel expenses associated with the computer center are normally recovered indirectly in the algorithm rates.

Dedicated resources (communications lines, disk, etc.) are usually billed separately.

Remote expenses (minicomputers, terminals, personnel, supplies) are considered the user's responsibility whether he pays directly or is billed through the center.

Service functions which can be easily accounted for, such as data entry, are also billed directly to end users.

For obvious reasons, the pressure on the dp manager is to reduce the charges to end users. This pressure comes from both general management and end users. In 1978, the easiest and most effective way to lower data center costs would be to cut back on central site printing.

For example, a large scale computer (IBM 370/168 class) will produce approximately 3,000,000 pages of output per month. This will result in the following approximate costs (assuming here an IBM 3211 or 1403-N1 printer):

	Monthly Costs/	Costs	Page
Printer rentals	\$15,000		0.5c
Supplies & forms	30,000		1.0c
Handling	45,000		1.5c
Total printing expense	\$90,000		3.0c

Don't let static kiss your computer's memory good-bye!



Set up islands of protection with 3M Velostat Brand electrically conductive floor mats!

Static on personnel, discharged into a terminal, can upset the logic of your terminal, mini, or CPU . . . can send erroneous data . . . permanently damage circuits causing costly downtime and repair. No equipment is 100% immune. Some computer equipment makers report that as little as 200 volts of static can cause serious problems!

VELOSTAT Mats create positive paths to ground . . . drain static away from terminal operators . . . keep them static free. Simply place the mat where the operator must step on it to reach the keyboard, and the VELOSTAT Mats provide passive protection in such key areas as these:

- Around Data Entry, POS and Bank Terminals
- At Minicomputer and Word Processing Stations
- As a floor runner in Computer Room Entrances
- In front of Computer Printers and Disc Drives

TO: Static Control Systems
Dept. BZF-98
3M Company, St. Paul, MN 55101



YES, I'm interested in keeping static away from my terminal with VELOSTAT conductive floor mats.

- Please have a 3M Static Analyst call.
 Send more information.

Name _____

Title _____

Company _____

Area Code _____ Phone _____

Address _____

City _____ State _____ Zip _____

4TUNE: Now you can make MVS earn its keep.

Data Processing Management is becoming aware of a problem that systems programmers have long known existed — the trials of MVS.

MVS typically consumes as much as 50% of your processing power. It is the single largest consumer of key system resources. It is not self-tuning. And, unfortunately, it is also tight-lipped. MVS can and will hide problems that have serious impact when they surface.

Resolves MVS Problems.

The only way to guarantee MVS efficiency is to give systems programmers

the ability to effectively fine-tune MVS performance. The newest addition to the CAPEX family of System Management Products, 4TUNE, does just that.

Specifically designed to identify and eliminate performance problems, 4TUNE provides concise information via reports, distribution diagrams and time plots at four levels: system, address space, control section, and even instructions within control sections.

Systems programmers can now have a tuning aid that is capable of resolving their most complex MVS systems problems, and as a result,

improve the performance of the MVS system. That capability successfully eliminates the costly guesswork in systems tuning.

The 4TUNE Solution.

If you're concerned with eliminating guesswork and maximizing MVS performance; and if the trials of MVS have prevented effective system management, start making MVS earn its keep. Look into the 4TUNE solution. Mail the coupon or phone (602) 264-7241.

CAPEX CORPORATION
Atlanta (404) 261-3553 • Boston (617) 329-6170 • Chicago (312) 596-6550 • Dallas (214) 238-7191 • Los Angeles (213) 923-9216
• New York (201) 262-8888 • Other offices worldwide.



Capex Corporation
2613 N. 3rd St., Phoenix, AZ 85004

Gentlemen:
I'd like to make MVS earn its keep. Tell me more.

Name

Title

Company

Address

City State Zip

Phone

Model

CW

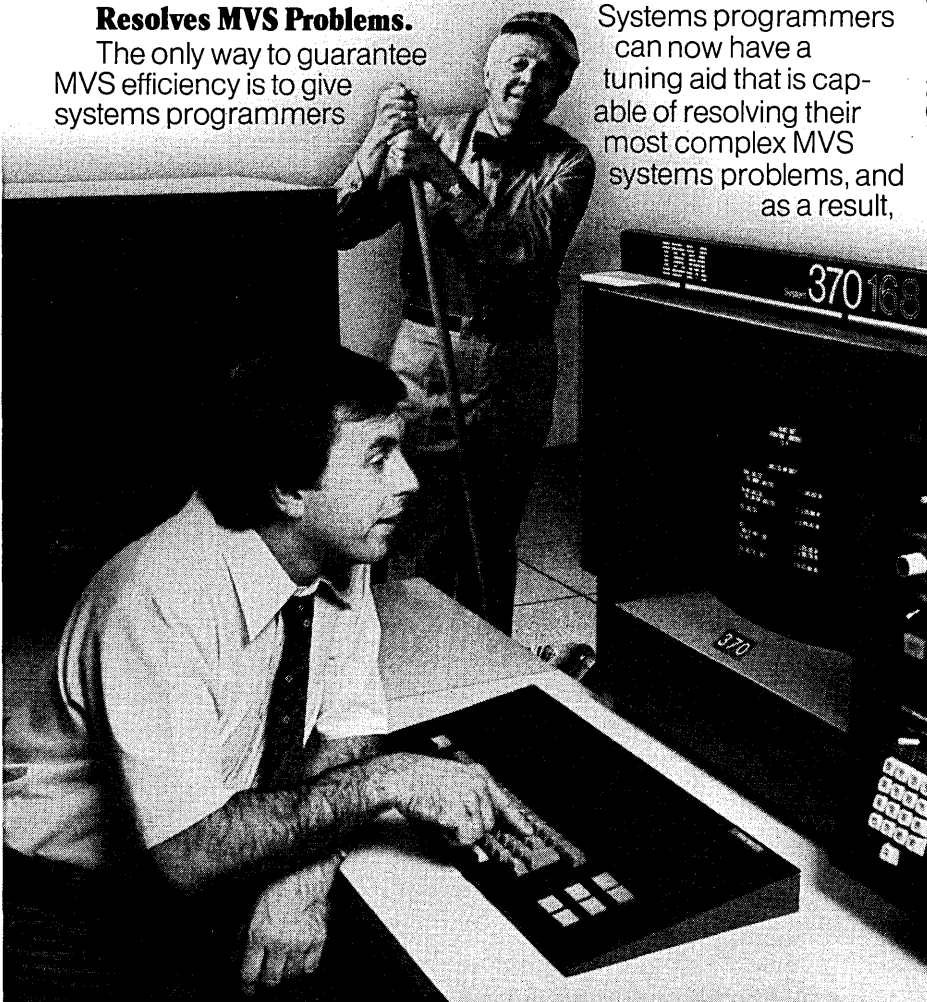

"Your copier just copied Aunt Bea's cake recipe, Ed's resume, and worse... your Marketing plan for the next year."

Whether you or your employees realize it or not... they're stealing. That's not a very nice word... but it's a word that must be dealt with in today's business and industry.

Aunt Bea's recipe and Ed's resume you can probably cope with... but don't let your marketing plans be copied. Get a Rusco CPM 500, and you'll probably never have to worry about Aunt Bea or Ed's resume. Or even your marketing plans.

And the Rusco Electronic Systems' CPM 500 Copy Monitor can prevent it from happening. When used in conjunction with a Rusco Programmable CARDENTRY Central Controller System, the CPM 500 gives your company the ultimate security in restricting who uses the copy machine... and *when* they use it.

Another problem you might not be aware of (or refuse to face the facts) is industrial espionage. It costs companies thousands upon thousands of dollars per year! Maybe even *your* company.

As you know, the average price of a copy is \$.05 and a bit of simple arithmetic will show you how much you're losing per day because of so-called "innocent" copying. Not to mention the espionage that might be occurring.

The Rusco CPM 500 Copy Monitor offers you *exact* and *definite* control of your copier. It tells you individual user I.D., number of copies made, time and day. And unauthorized attempts are also recorded!

Call your Rusco Sales Consultant today toll free at 1-800-528-6050, Ext. 691 or write Rusco Electronic Systems, 1840 Victory Blvd., P.O. Box 5005, Glendale, California 91201.

THE
CARDENTRY
COMPANY...

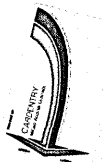

For a brochure detailing CARDENTRY's exciting capabilities, call toll-free 1-800-528-6050, Ext. 691 (in Arizona call 1-800-352-0458) or write Rusco Electronic Systems 1840 Victory Blvd., P.O. Box 5005 Glendale, Ca. 91201

RUSCO
ELECTRONIC SYSTEMS

A DIVISION OF ATO

CIRCLE 146 ON READER CARD

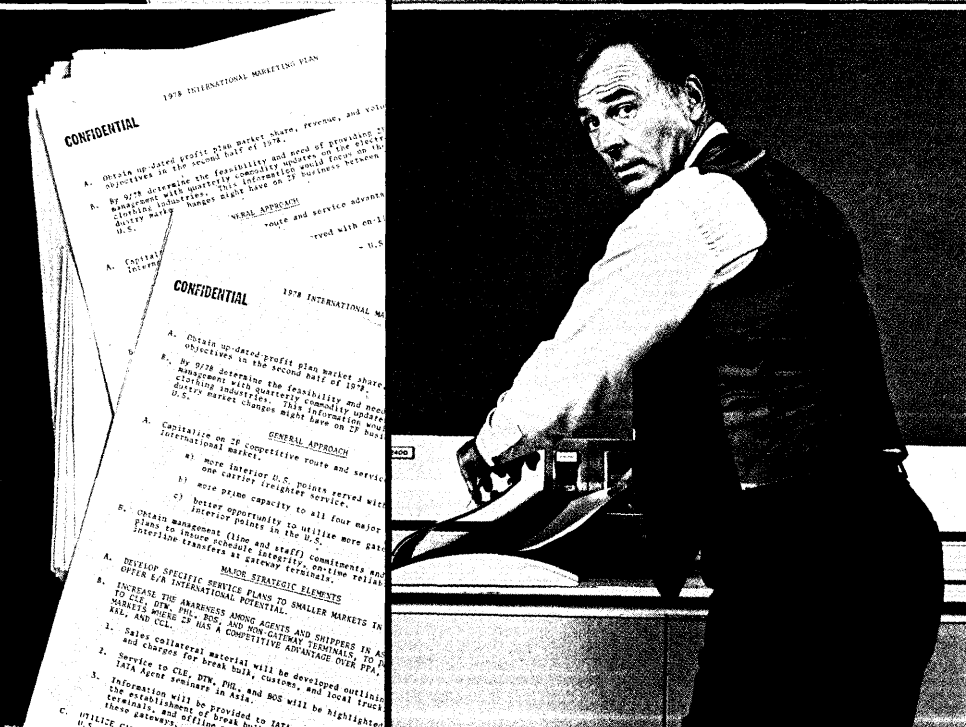
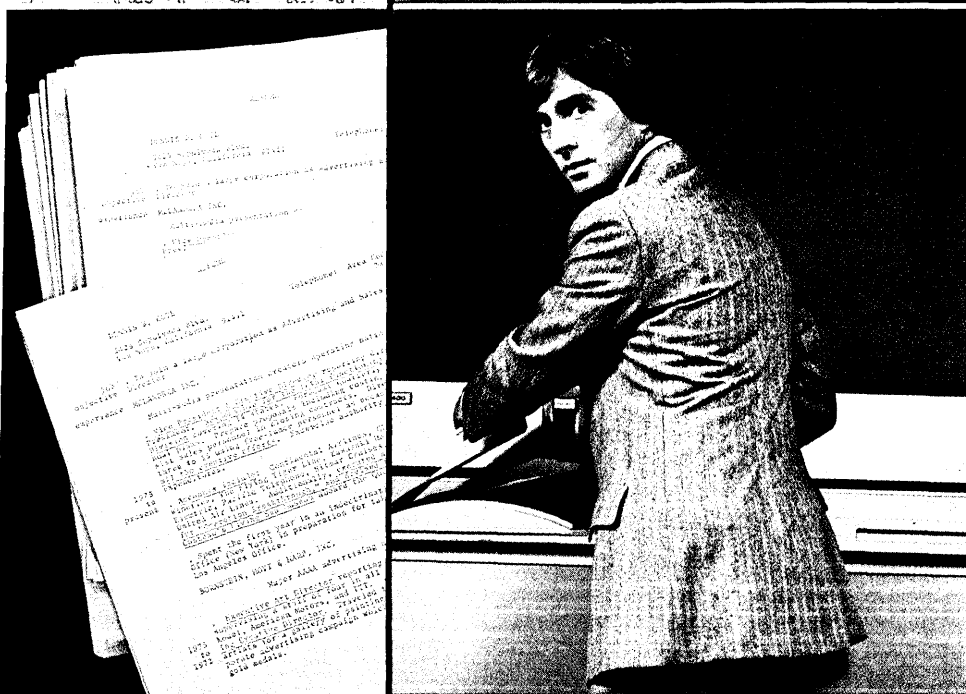
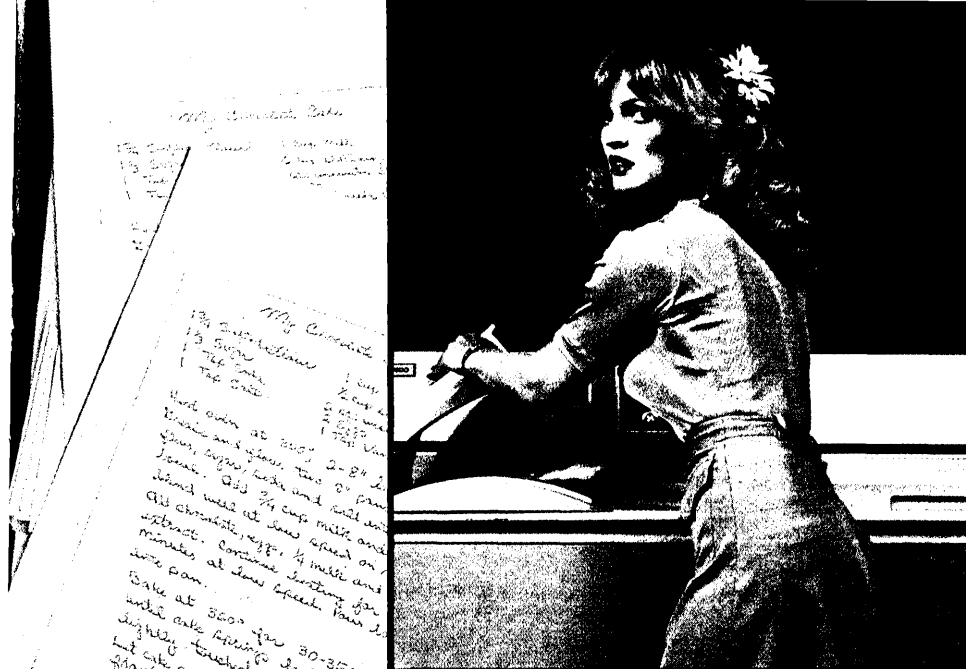

Users of distributed processing, small business, and word processing systems will find 60% of their costs are related to paper output.

These numbers are conservative and dp management knows they will increase as costs of paper and personnel continue to rise. The total cost of running a large central site (hardware, software, personnel, space, power, light supplies, etc.) which must be recovered under the billing algorithm will be approximately \$330,000 per month. This means the dp manager has the potential for transferring 20% to 30% of his total accountable costs directly to end user control by distributing the printing to user sites (local or remote). This has numerous advantages:

1. It will lower the amount he must recover under the billing algorithm.
2. It will remove the most critical bottleneck in responsiveness from his direct control. (Printing and distribution of reports is the major factor in turnaround time.)
3. It is a straightforward solution to an immediate problem which can be easily accomplished with today's hardware and software without significant conversion effort.
4. For really heavy print loads which cannot be conveniently or economically transferred to user control with 1978 technology, there is always Computer Output Microfilm. It has been estimated that 30% to 40% of current computer paper output lends itself to COM. The dp manager at a large installation could cut his total printing production costs by approximately 25% through its use.

Under any circumstance, large central site volume printing *must* receive immediate attention from responsible dp management, and the answer to high print volumes is not faster printers. For example, the savings achieved by newer high speed printers in the case cited above would be as follows:

	Printer, Supplies & Handling (Cost for 3 Million Pages)
Case cited (using IBM 3211 or 1403-N1)	\$90,000
IBM 3800	\$81,000
Honeywell Page Printer	\$75,000

Savings of 10% to 15% do not prompt most dp managers to change, and that is especially true when more attractive alternatives are available.

Therefore, we expect that large central site printing will be reduced significantly before 1982 and will virtually disappear by 1988. The mere distribution of printing obviously does not

eliminate paper, and it may actually increase some costs. (For example, printers and direct operational costs may increase in a less efficient distributed environment if the same volumes are maintained.) However, it is probable that these costs will be obscured by their transfer from dp budgets to user budgets, and the increase may be completely offset by decreased distribution costs.

Incidentally, the most important result of distributed printing will be to make end users aware of the true cost of printed output.

DISTRIBUTED PROCESSING—1982

By 1982, end users will have responsibility for a substantial portion of the data processing function. Data entry (including editing) and printing will have been distributed, and these basic functions currently represent in excess of 50% of commercial data processing costs.

The following facts will become apparent concerning printed output:

1. Printers are the most expensive component associated with mini-computer and intelligent terminal operation.
2. Printers are noisy and not suitable for many end user environments.
3. Paper itself is expensive.
4. Paper handling costs are substantial.

At this point, it is important to note that these observations will become apparent to first-time users of electronic technology (including word processing and small business systems) as well as to those who have previously purchased services from centralized dp departments.

There is an interesting case study of end user rejection of obviously expensive (and obsolete) technology on the IBM System/3. The designers felt the first-time user would obviously want a card oriented machine. After all, from unit record shops, 650s and 1401s, mighty commercial computer installations have grown. Those with an interest in punch cards (paper manufacturers, card converters, and IBM) projected new life for punch cards. Fortunately, the first-time user of System/3 was not necessarily card oriented—but cost oriented. He could not understand the logic of keypunching and feeding cards through a card reader when he could key in his data directly through a terminal. That was the beginning and end of the great card revival.

When the end user analyzes the cost of his distributed system in 1982, he will discover the following:

- A processor, 20MB to 30MB of storage, and four crt terminals will be available for \$20K.
- A printer of reasonable speed and quality to continue today's paper report-oriented environment will cost \$10,000 (200 lpm to 300 lpm).
- The printer will be the least reliable component in the system and will cost the most for maintenance.
- The operational cost of printing will be between \$1,000 and \$2,000 per month (assuming the use of paper for information display and storage is continued).
- The printer will be the limiting factor on responsiveness, and if scheduling becomes a problem, a full-time operator may be required, adding to the expense.
- The monthly costs of 1982's print oriented systems will break down as follows:

	300 lpm Mainframe	Printer
Hardware (including maintenance)	\$600	\$300
Software	600	—
Supplies*	—	600
Handling (paper)	—	900
	<u>\$1,200</u>	<u>\$1,800</u>

* Assume 40,000 impressions (pages or documents) per month.

Approximately 60% of the data processing expense will be directly associated with paper output. In addition, the printer will be the least reliable component of the system, the major response bottleneck, and require the most human attention. Good systems design will dictate the elimination of paper wherever practical.

WHERE THE PAPER GOES

To estimate how much paper can be eliminated, it is necessary to understand where the paper goes. This obviously varies tremendously across both computer installations and industries. Table 2 shows a generalized distribution.

The data processing function itself is one of the biggest users of paper, and programmers are notorious for generating the greatest volume for the least



CONSIDER THE SOURCE.

TI's Series 700 Distributed Processing Systems save you time and money by preprocessing your data.

Today, business thrives on the efficient exchange of information between remote business locations. The cleaner the data received, the faster the turnaround time. The faster the turnaround time, the lower the operating costs. And the greater the opportunity for a more profitable, smoother running operation.

To speed up your data traffic and process jobs on the spot instead of tying up your mainframe, TI has developed a family of distributed processing systems. Our new Series 700 Family includes the 770, a low-cost remote intelligent data entry station; the new 771, which adds diskettes for increased power; and the high-performance 774 intelligent terminal system with up to eight work stations and disk data storage.

Our Series 700 Family puts some effective communications skills at your fingertips: powerful editing and preprocessing at the source for cleaner data and less computer load, and quick, direct communication with your computer for faster turnaround time. It sends and receives at night, unattended, saving on

phone rates and without additional operator costs. It prints paychecks, sales orders, reports and all your data on our reliable OMNI 800* printers, and has them ready for you in the morning.

Built into our Series 700 Family is over 30 years of experience in the electronics industry and the technical expertise and support of our worldwide organization of factory-trained sales and service engineers, backed by TI-CARE†, our computer-automated field service dispatching and information system.

To see how efficiently we can move your data, whether it's across the country or just down the street, call your nearest TI sales office, or write Texas Instruments Incorporated, P.O. Box 1444, M/S 7784, Houston, Texas 77001. Or call (512) 258-7305.

TEXAS INSTRUMENTS
INCORPORATED



* Trademark of Texas Instruments

† Service Mark of Texas Instruments

Copyright © 1978, Texas Instruments Incorporated

TEXAS INSTRUMENTS.

We put computing within everyone's reach.

CIRCLE 138 ON READER CARD

use. Most of this usage can (and will) eventually be eliminated.

Paper which is used to communicate outside an enterprise is the most difficult to eliminate (communications to customers, vendors, government, etc.). However, there is one feature of this paper output which will encourage its elimination—most of it is used to evoke a response which must be converted to electronic media. This chain of media conversion (paper-to-electronic to paper-to-electronic, etc.) as transactions are processed is unbelievably expensive and is adding untold \$ billions to what consumers pay for goods and services.

Internal production represents 50% of the paper used, based on the generalized model. This is obviously a significant variable in the overall equation, and the specific uses (applications) are practically infinite. However, it is possible to characterize these paper uses in a more general fashion. Fundamentally, internal reports fall into three categories: (1) operational reports directly associated with an enterprise's basic functions and requiring some action; (2) management reports which may or may not prompt action but which are used for accounting, control and planning; and (3) archival data storage which seldom prompts action but is required for some reason (legal, policy, or backup).

Once placed in these categories, the possibilities of media replacement becomes more readily apparent.

ALTERNATIVES AND RISKS

The cost analysis indicated that paper will tend to increase as a percentage of total data processing costs. There is also a more significant hidden cost which was not mentioned: timeliness. While it is difficult to quantify the value of timely information, it is possible to define specific situations which demonstrate substantial risks if timely information is *not* available.

The risk in certain competitive situations is apparent. If a vendor cannot supply goods or service upon demand, he loses the business. Reservations systems are an excellent example of how immediate information must be available in order to be competitive. Paper listings of airplane loadings and available hotel accommodations are no longer satisfactory in terms of being able to distribute operational information or service the customer.

Consumer goods of all kinds must be available upon demand or the customer will find another source. Inventory information cannot be distributed rapidly enough using paper media.

Government services are too costly to dispense using paper com-

GENERAL DISTRIBUTION OF COMPUTER GENERATED PAPER OUTPUT

Type of Usage	1978 % of total paper output	Possibility of decreasing paper output—1982
Computer center operations	7.5%	High
Program development & maintenance	17.5%	High
Production—internal to the firm	50.0%	Varies
Production—external to the firm	25.0%	Low

Table 2. Paper used internally by the dp department, especially the high volumes churned through by programmers, may be easy to replace with electronic media. Most difficult to convert will be the paper used to communicate with businesses, customers, and agencies outside the firm.

munications. A recent study in Wisconsin showed that case workers who previously handled only two cases per day could handle six to eight using distributed processing. Personnel cost savings of 60% to 75% cannot be ignored by responsible government organizations, and fiscally irresponsible government is rapidly becoming the number one issue for the American public. The classic "paper pushers" are coming under increasing attack.

Government reporting requirements are a tremendous burden on both private enterprise, individual citizens and other governmental entities. Whether or not these "requirements" are justified can be disputed, but the cost must be reduced under any circumstance. Just as the census bureau collected more data than it could process in 1890, the federal government can make use of much data currently being collected only at tremendous conversion costs from paper to electronic media.

Data processing management which does not recognize the true cost of paper and the enterprise's requirements for responsiveness will soon find systems design responsibility being distributed to end users (along with willing vendors). Continuing with "business as usual" will result in the dp function becoming custodial in nature; instead, dp should exert leadership.

PREDICTIONS FOR 1982

By 1982 we expect to see the following systems design and implementation fundamentals:

No new systems will be designed which include the classic cycle of source document—keypunch—punch card—computer—error listing—user—source document (correction)—keypunch, etc. Thus, not only will cards be eliminated but so will a substantial amount of paper flow.

The majority of programs will be developed and tested on-line using crt's

rather than hardcopy terminals.

New operational systems will be designed to eliminate paper at the work station (factory floor, sales location, point-of-transaction).

New management systems will be designed to minimize reporting by eliminating voluminous listings of data. Fundamental analysis will be built into the reporting structure, because management will demand it and because the facilities will be available to make such reporting rather simple. Ad hoc reporting will make many voluminous reports now kept in file cabinets or desk drawers unnecessary. (However, most management reports will still be paper.)

New systems incorporating voluminous archival storage will make much increased use of COM as cost spreads become even more significant.

Interorganizational reporting (and transactions) will trend more toward substitution of electronic for paper media, especially in financial transactions. However, paper will still be the prime medium for reporting.

Communications between business or government and individuals will remain very much as it is today, except for an increasing trend toward consolidating financial transactions. (New banking services will include more consolidated billing and payments, such as for utilities and services. A first class stamp will probably be over 20¢ by 1982, and this cost alone will justify consolidation.)

AND FOR 1988

Most of the above developments will relate to the implementation of *new* systems and many old (and obsolete) systems will still exist and continue to grow through 1982. However, by 1988 sufficient cost pressure will have been exerted through major communications and computer technological developments in the early 1980s to justify conversion of old systems. Systems design projections for 1988 are as follows:

Compare the new Sanders Graphic 7 with other interactive terminals.

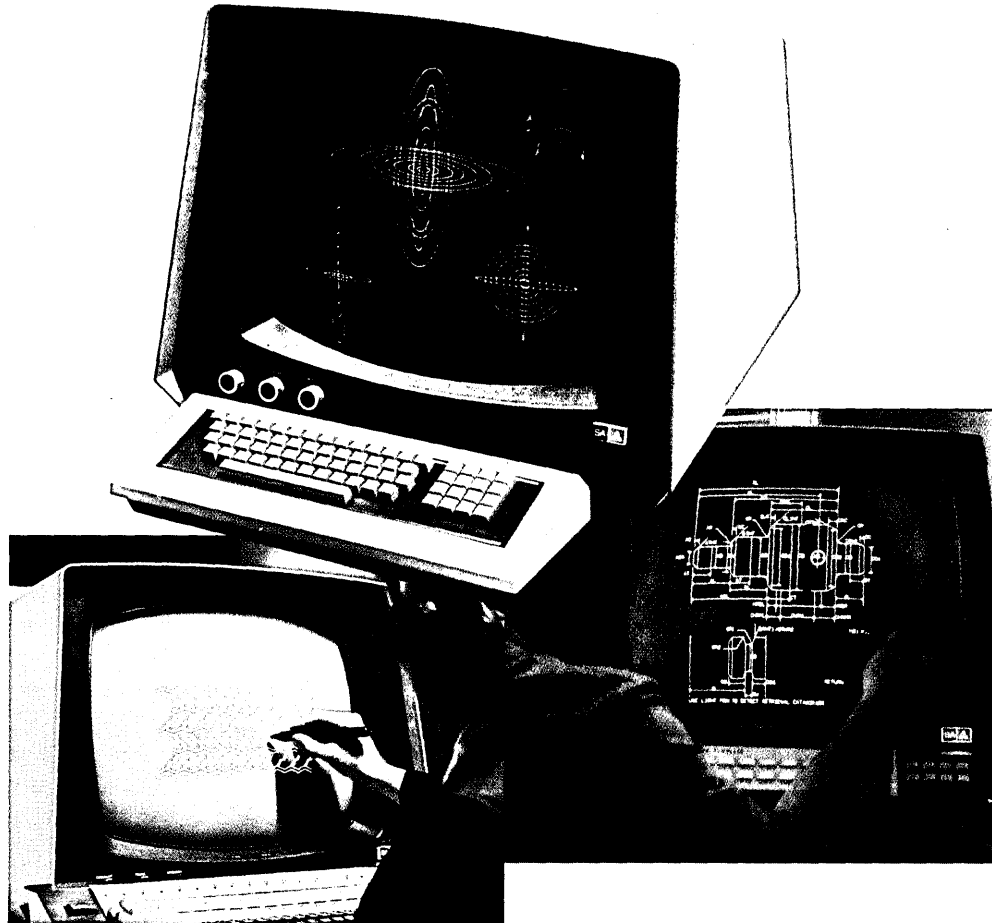

You'll draw a graphic conclusion.

Sanders' new Graphic 7 is an intelligent terminal with all necessary hardware and software as standard—not cost-you-extra—features.

But the Graphic 7 doesn't just save you money when you buy it. It also saves you money after you buy it.

Simply wheel your Graphic 7 through the door and plug it in. No installation problems.

Your programmer won't have to spend much time with your Graphic 7. It comes pre-programmed.

And your operators will be able to handle your Graphic 7 after a 10-minute briefing, because it works with a one-button initialize.

Application programs? Our Fortran-based graphic support package can reside in any host that supports Fortran.

And with the intelligence at the terminal, there's minimum impact on the host. You can do more work faster.

Sanders experience? Our graphic terminal systems are used in computerized production projects. Tire-tread design. Avionics defense

systems. Flight training. Land-use management. Air traffic control. And dozens of other areas.

Compatible, fully equipped, low priced. What other graphic conclusion can you draw than the new Sanders Graphic 7? Send for specs and specific applications.

Sanders Associates, Information Products Division, South Nashua, NH 03061.

603-885-5280.
TWX: 710-228-1894.





**“As NCR promises,
our conversions have been
problem-free and fast,” says
Tom Crabtree of Pier 1 Imports.**

DP MANAGER CRABTREE: It's hard to believe our volume has grown so fast that this NCR Criterion is our fifth system since 1970. And our improvement in productivity has been even more dramatic. Our year-end-closing program – just five years old – once took 12 hours. Now it runs in just 18 minutes.

DP OPERATIONS MANAGER CORMIER: Our last upgrade was impressive just by itself.

CRABTREE: It was. Our figures tell us that we achieved a 38 percent increase in thru-put when we went from the NCR Criterion 8550 to the 8570.

CORMIER: As you know, the biggest job we have is maintaining a perpetual inventory on close to half-a-million items – 1650 items in each of the 275

stores. We updated 13,000 items an hour on the 8550. We are doing 30,000 an hour on the 8570. That really takes the pressure off. And the transition was smooth, too.

CRABTREE: They all were. As NCR promises, our conversions were problem-free. We just moved the new equipment in and the old equipment out. And that was all there was to it.

CORMIER: The big advantage is that we upgrade only when we are experiencing an overload and have no time available for recompiling and the other usual conversion chores. NCR's Migration Path Engineering helps us at a time when we are desperate for help.

CRABTREE: We are going to have the same kind of transition when we install VRX – NCR's Virtual Resource Executive. Plus another 20 percent increase in thru-put.

CORMIER: It will really make the system easier to operate.

CRABTREE: It sure will. You will be able to run up to 35 jobs at one time. VRX will allocate memory and resources automatically. And automatically schedule jobs to cut down the demands on the operators. It will handle memory swapping. It will even watch for memory thrashing and program loops – and will automatically alter the job mix to eliminate these problems if they occur. The key word is – automatically.

In the NCR office near you, there is an account manager who can assure you of effortless upgrades, once you are on the NCR path.

To learn more about what an NCR system can do for you, phone your local NCR office. Or write to EDP Systems, NCR Corporation, Box 606, Dayton, Ohio 45401.

Thomas F. Crabtree, Jr. (right) is Data Processing Manager of Pier 1 Imports, Inc., a national chain of import stores. Donald Cormier is Data Processing Operations Manager.



Dp managers who do not recognize the true costs will lose their responsibility for systems design.

A high proportion of "systems development" will be the responsibility of the end user, who will not be concerned at all with program listings or memory dumps.

Most operational systems will be based on information retrieval rather than reporting. (Data capture at the source is implicit in operational systems.)

Management will be part of the end user population and will satisfy a high percentage of its information requirements without recourse to programmers (and today's reporting facilities). Paper will be used to record plans and answers, not data for analysis.

The weening of management from paper dependency will be speeded by integration of office systems and communications with data processing. In addition, both upper and middle management will have grown up living with computer and communication technology—most of them from college days.

New systems requiring archival storage will find electronic storage cheaper than paper and much more convenient than COM. Electronic transmission will be cheap enough to shift and maintain the archival store on either a centralized or distributed basis.

Electronic communications will be substituted for most paper reporting and communications (including mail) in all new commercial systems. For those who do not have the resources to implement such systems, communications services will be available to permit inter-company communications. These services will be cheaper than maintaining the old "paper mills."

New systems developed by government will encourage electronic communications with the business and financial communities, and will dictate electronic reporting from other governmental entities (state and local).

Communications between business or government and individuals will continue to be paper oriented, but electronic facilities for transaction processing will go "public" through financial institutions, utilities, service bureaus, and perhaps through the U.S. Postal Service (regular first class postal rates will exceed 30¢). Individuals will be able to have terminal access for bill paying, income tax assistance, and information retrieval through the organizations mentioned above. In fact, home terminals (even if only the Touch-Tone phone) and computer systems will be able to connect to both public and private networks for the purposes mentioned above.

However, even though home computers may be a multi-\$ billion industry in 1988, they still will be available to a relatively small percentage of the population. This does *not* mean systems designers should ignore this possibility because the real impact will occur in the early 1990s.

Of the terminals and home computers installed, many will be related to part time (or full time) work from the home. Many of the "workers" from home will be directly associated with the computer/communications industries (programming systems designers, etc.).

The cost and performance characteristics of electronic media, the demands of operating management, and the pressure on dp management to produce, all point toward the replacement of paper oriented systems on a relatively rapid basis. The impact on actual paper usage obviously depends on how rapidly existing systems are replaced. And this in turn depends to a large degree on the interconnection (tight or loose) of existing systems. While such impacts are difficult to predict, the most important fact is clear—*paper usage is not going to follow traditional patterns and keep growing indefinitely.* Busi-

ness, government and individuals cannot afford it! *

Mr. Tyler's feature has been adapted from "Electronic Versus Paper Media," a 90-page report authored by him for SBS Publishing, 4320 Stevens Creek Blvd., San Jose, CA 95129. The report includes forecasts for cost trends and markets related to business forms, and is priced at \$600.

TIM TYLER



Mr. Tyler is an independent consultant in computing and communications, based in Mountain View, Calif. He was formerly a vice president of Singer Information Services Co., responsible for systems and programming personnel and computer operations. Previously with IBM and Southern Railway, he was involved in systems evaluation, and the management of systems personnel.

Maybe CALCOMP

doesn't think enough of their own plotters to buy them when they're used, however **Graphic Resources Corporation** does! If you now have, or will soon have a CALCOMP plotter to dispose of, **Graphic Resources** would like to make you an offer. For a non-obligation quote on your 936, 1036, 563 or 960 used CALCOMP plotter, call us COLLECT at (714) 898-3584 and (213) 598-3318.

So what if CALCOMP doesn't buy used plotters, Graphic Resources will.

graphic resources corporation

■ CORPORATE OFFICE: Huntington Beach, CA ■

■ OTHER OFFICES LOCATED IN: ■

Houston, Denver,
Washington D.C., Hartford, Calgary

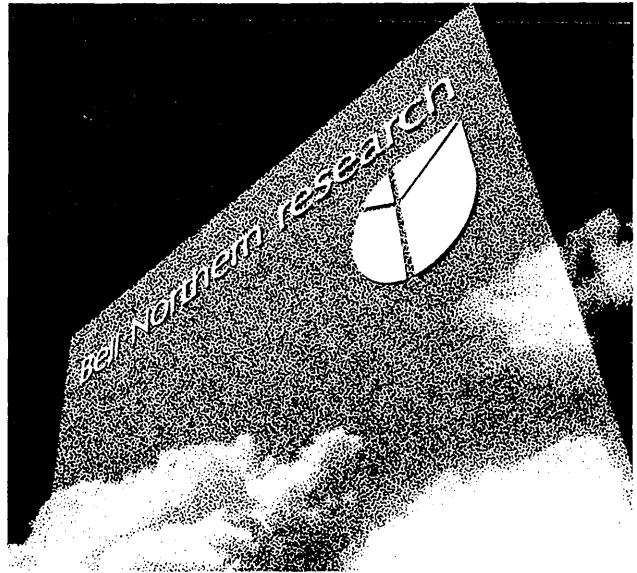
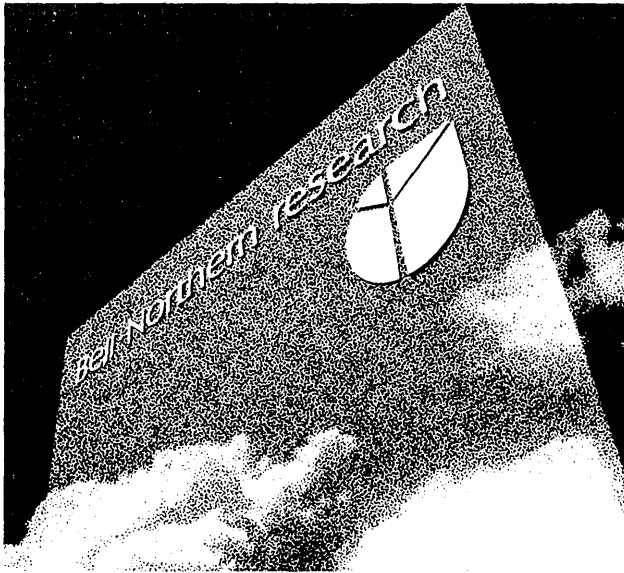

Join a Leader... and help Software Technology...

Sophisticated software design and innovative techniques are a must when aiming to bring advanced telecommunication products to the market place. Recognized SOFTWARE innovators at Bell-Northern Research continue to drive this growing technology to create the best products possible. As a member of our professional team, you will have the opportunity to broaden your experience and move forward in your career at the same time. We offer an R&D environment which is receptive to your ideas. You will quickly discover that team work is essential, but individual achievement is recognized and rewarded.

Our need for talented people continues to grow with our expanding work programs which encompass design and development activities in the following:

- Data communications software
- Mini/microprocessor applications
- Computer languages
- Software Systems Testing
- Advanced operating systems
- Computer architecture (H/W & S/W)
- CAD Systems
- Data base systems
- Real-time software
- Word processing systems
- Distributed computing systems
- Software reliability
- Software Engineering Systems

We are presently recruiting the best talent available in the above fields to augment our team of software specialists.

Application Software

- Call processing software development for digital switching systems applications. Real-time programming experience in high level and/or assembler language is required. (SD-01)
- Design of new feature and network software for switching, business product and data communication systems. A strong emphasis or experience is required with real-time software, mini/microcomputer systems, advanced programming techniques and high-level languages. (SD-02)

- Mini/microcomputer software development for computer system products that centralize the monitoring and control function for the telephone network. Real-time software design, mini/microcomputer applications, computer network design and data base design are applicable experience areas. (SD-03)
- Software development for both scientific and business information processing. Expertise is required in the use of data bases, interactive computer graphics, minicomputers (PDP-11) and large computers (IBM 370). (SD-04)
- Development and application of state-of-the-art CAD/CAM systems applicable to P.C.B.'s, IC's, electronic equipment and mechanical piece parts. Software development experience should include: algorithm design, electronic design, hardware design languages and simulation systems. (SD-05)
- Firmware development for microprocessor-controlled digital transmission and switching systems. Logic circuit design experience is highly desirable. (SD-06)

Support Software

- Work involves enhancement and maintenance of switching and data network software such as compilers, assemblers, various data base systems and/or special utility packages. Implementation is on an IBM 370 using PL-1 and IBM assembler. (SU-01)

Database Systems

- Database design and application software development. Candidates must have the ability to carry through software development from system analysis to software implementation and installation in a user environment. Knowledge of structured programming, top-down design and good documentation principles is required. (DB-01)

Advanced Operating System Design and Development

Design and implement real-time operating systems for voice switching applications as well as for business and data communication systems. Experience in the design, implementation or maintenance of at least one operating system is required, and exposure to real-time applications and data base design is highly desirable. (OS-01)

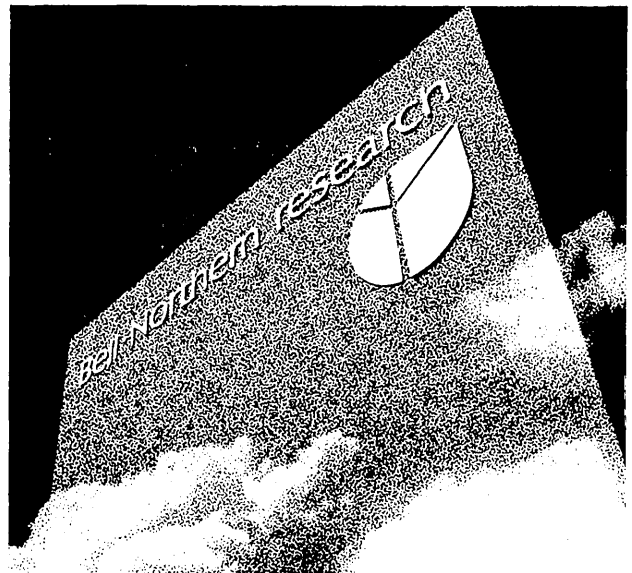
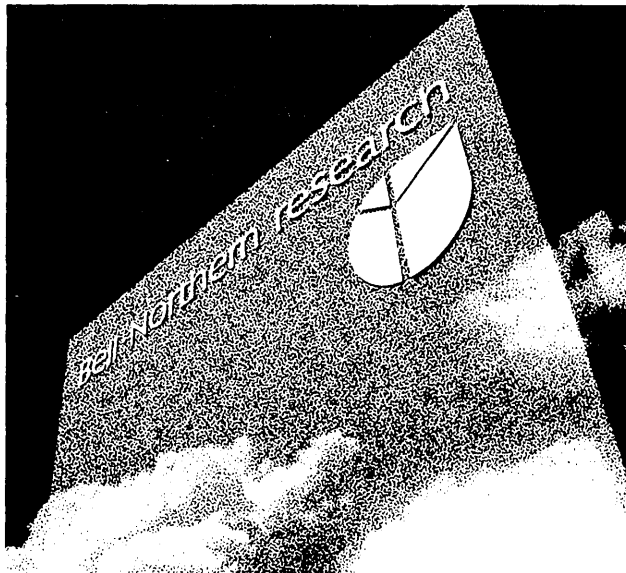

develop tomorrow's today!

Software Systems Development

- Systems programmer to become involved with functional analysis and software system design on a real-time computer system. Design areas include system startup, initialization, processor fault resolution, reconfiguration of control subsystems and diagnostics for processor subsystems. (SS-01)
- Systems programmer to work on the implementation of a disk file system as part of a disk operating system development team. This work will extend into a study of the general communication problems involved in tightly coupled, message-driven computer networks. (SS-02)
- System programmers to join a group involved in the design and implementation of telephone central office data services. Past experience in operating systems design, data base management or disk file management will be applied to the specification and realization of page oriented document storage and retrieval systems. (SS-03)
- Work at the fore-front of Software Engineering technology. Assist in the development of software design languages and methodologies, data-capture graphics systems, design databases and computer-aided design systems applied to software development. In-depth experience of systems software development and/or experience in any of the above is required. (SS-04)

Computer Services Development

- Participate in the development of electronic mail and messaging systems. This group designs facilities for composing, editing, sending, receiving, forwarding and distributing messages. Required skills include: high-level language programming, systems design experience, and an understanding of time-sharing and interactive computing. (CS-01)
- Participate in the development of high speed communication network systems for distributed computing applications. Required skills include: assembler level programming, high-level languages, data communications experience, and knowledge of packet switching and communication protocols. (CS-02)
- Systems programmer to support and enhance the VM/370 operating system on a 370/168. Install IBM system level changes, isolate and solve software programs in CP, CMS

and RSCS. Enhance these system components to add new functions, improve performance and increase security. Experience requirements include at least one year of systems programming with an IBM Virtual Storage operating system, a good understanding of IBM system 370 architecture and experience with IBM assembler. (CS-03)

- Programmer/analyst to support DEC PDP-11/70 computer systems. Responsibilities will include system generations, problem diagnosis, correction and enhancements to the operating systems to provide improved performance, new functions, increased security and better user interface. DEC system software experience is a must. (CS-04)
- Programmer/analyst to design and develop corporate Management Information Systems. Demonstrated ability in areas of systems analysis and design, advanced programming and data base design is necessary. (CS-05)
- Evaluate all aspects of computing technology as applicable to the corporate computing plan. Familiarity with state-of-the-art computing technology as offered by the major minicomputer and main frame manufactures, and experience in HW/SW system evaluation are absolute requirements. Knowledge of communications, storage subsystems, test equipment and terminal technology is desirable. (CS-06)
- Programmer experienced in software performance techniques to work in the areas of application program efficiency, performance tools, software usage statistics and new software evaluation. Experience should also include IBM assembler, at least one high level language and knowledge of OS, VS or CMS operating systems. (CS-07)

These positions in Ottawa offer career growth opportunities, attractive salaries and a comprehensive company paid benefit plan.

If you are interested in what we have to offer, let's get together and talk it over. For interview arrangements please submit a detailed resume quoting file number 38/78 and position codes to:

**Mr. R.G. MacMeekin
Manager — Recruiting
Bell-Northern Research Ltd.
P.O. Box 3511, Station C
Ottawa, Ontario
K1Y 4H7**

An E-sized drawing in 13.5 seconds.

Gould's 5400 printer/plotter will produce an E-sized drawing in 13.5 seconds. That's faster than any competing electrostatic printer/plotter. With a paper width of 36" and a speed of 3.25"/second, the 5400 generates over 48 square feet of hardcopy per minute.

Designed for applications where fast turn-around and high throughput rates are important, the 5400 is ideal for computer-aided design, seismic data plotting, and business graphic applications such as PERT/CPM, Gantt, and others.

Gould's patented negative-pressure, closed loop toning system ensures high contrast dry

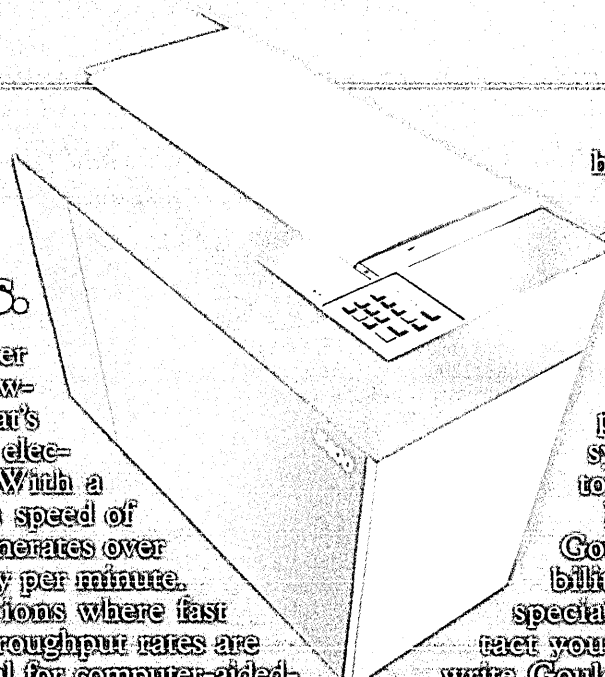

hardcopy even at the maximum plotting speed of the 5400. Print resolution is 100 dots per inch, horizontal and vertical. In addition, a staggered image head produces overlapping dots for high contrast images. A user-oriented control panel features a unique LED system for continuously monitoring paper supply.

For additional information on Gould 5400 printer/plotter capabilities, software, interfaces and special application packages contact your Gould representative. Or write Gould Inc., Instruments Division, 3631 Perkins Avenue, Cleveland, Ohio 44114 (216) 361-3315. For brochure call toll free: (800) 325-6400, ext 77. In Missouri: (800) 324-6600.



GOULD

HARDWARE

OFF-LINE

Rockwell International's Electronic Systems Group has delivered a prototype Solid State Data Recorder to NASA's Langley Research Center. The unit uses bubble memory, and has PPS-8 microprocessors for read and write control. Designed to have a one megabit capacity, the recorder can record one to four serial channels, or an eight-bit parallel channel. The prototype contains only 12.5% of the unit's designed memory capacity, and will be studied to see how improvements over mechanically driven recorders can be made.

Texas Instruments also has something new in bubble memories: a 1/4-megabit chip, the TIB0303. The chip will be available for prototyping at the end of this year, with a price of \$500. TI also announced that its 92K-bit bubble chip has entered volume production, with availability 6 weeks ARO. It's priced at \$100 in lots of 100.

Pacific Southwest Airlines (PSA), a California intrastate air carrier, has installed an automated, credit card reading, ticket vending machine at San Diego's Lindbergh Field. The unit, built by Cubic Western Data, can issue one-way or roundtrip tickets to any of PSA's destinations, with the bill issued against any of six mag-stripped credit cards.

One-day delivery of first class mail? That's what the Danes hope to ensure with the installation of 10 CDC System 17s to control the sorting and routing of the nearly 2.9-million pieces handled by their central sorting office in Copenhagen.

In the first two years of marketing, IBM sold nearly 5,000 5100s with a total value of \$90-million. Sales of the recently introduced 5110, with floppy disks, will be limited only by production capacity, according to a Venture Development Corp. study, "Desktop Computer Markets." H-P, Wang, and Tektronix will be the other major forces, but "IBM can be expected to assume the lead in sales."

PORTABLE DATA ENTRY TERMINAL

If the telephone in this photograph looks unfamiliar, it's because both the phone and the Memoport 8 portable data entry terminal to its right are of European design. Intended for use by the proverbial traveling salesman, and anyone else whose job calls for on-site data collection, the Memoport 8 has 2KB of semiconductor memory, organized as 168 lines of 12-digit entries. Editing functions are provided from the keyboard. When the operator wishes to send the



unit's memory contents to the host computer, he dials the host, puts the Memoport's acoustic coupler on the phone, and hits the transmit key. Transmission to the central site occurs at 600bps. The receiving end is controlled by a mini-computer, which checks the validity of the transmission and confirms correct reception with an audible signal. The Memoport 8 sells for \$1,000; the central site mini-based receiver sells for \$12,000 to \$40,000 depending on capabilities desired. MEMO-TEL INC., New York, N.Y.

FOR DATA CIRCLE 384 ON READER CARD

GRAPHICS SYSTEM

A family of standalone imaging and graphics system, the RM-3000 series, handles color, gray-scale, and black and white displays. Based on DEC's LSI-11 and this vendor's RM-9000 or RM-9500 display controllers, the 3000 Independent Display System (IDS) can be configured to process data stored on floppy disks, rigid disks, mag tape, or in a host computer connected via a telecommunications link. Customers can select a variety of resolutions ranging from 256 elements by 256 lines to 640 elements by 512 lines. The 3000 IDS can support multiple workstations, as well as joysticks and other peripherals. Users can perform display

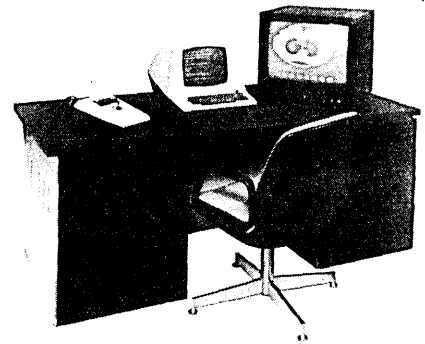

operations with a set of macro instructions supplied for the display controller's Z-80 microprocessor, and they can program the LSI-11 in macro assembler, FORTRAN IV, or BASIC. A FORTRAN Imaging and Plot Package is offered, as source code, to those wishing to purchase it. A basic RM-3000 IDS, consisting of a 64KB LSI-11, floating point arithmetic, RT-11 software license, dual floppies, RM-9000 or RM-9500 series display controller, and a desk console, sells for \$18,200. The user will also need to select a monitor to fit the application at hand. Oem discounts are offered. RAMTEK CORP., Sunnyvale, Calif.

FOR DATA CIRCLE 385 ON READER CARD

TAPE CONTROLLER

The TC-150 is an embedded magnetic tape controller for use with DEC's LSI-11 series. Providing both phase encoding (PE) and NRZ recording modes, the unit allows mixing of seven- and nine-track transports in any combination of up to eight units. It can be used with any transport having an "industry standard" interface, such as units produced by Pertec, Kennedy, Tandberg, and others. Tape units operating at speeds ranging from 12.5ips to 125ips are supported. The TC-150 is software compatible with any system capable of supporting DEC's TM-11. The TC-150 sells for \$3,500, including cabling for the first tape unit. WESTERN PERIPHERALS, Anaheim, Calif.

FOR DATA CIRCLE 386 ON READER CARD

WORD PROCESSING

This vendor has increased its potential market with the introduction of an entry-level crt-based word processing system expected to compete with elec-



tronic memory typewriters. The System 5 consists of two standalone models, both of which can be upgraded into the vendor's larger Systems 20, 25, or 30. The System 5 Model I includes crt and keyboard, diskette storage, and provision for connection of a single printer. With a 40cps daisywheel printer (introduced at the same time as the System 5), the model I sells for \$9,900. The model II has additional operator features, such as a glossary. With a 40cps printer, it sells for \$11,900. Both models offer media compatibility with the vendor's larger systems. WANG LABORATORIES, INC., Lowell, Mass.

FOR DATA CIRCLE 387 ON READER CARD

SMART MICROFILM RETRIEVAL

The microprocessor-based IMT-100 and IMT-150 intelligent microimage retrieval terminals can operate in a standalone mode, or on-line to a wide range of host computers. The IMT-100 is a reader only, while the IMT-150 is both a reader and a dry-paper printer. In the on-line mode, the host can send the terminal a block of image addresses, and the unit's microprocessor will handle retrieval without subsequent help from the host. In the standalone mode, an operator can specify which frames to fetch. The units also can remember the location of a frame for subsequent references—useful when an

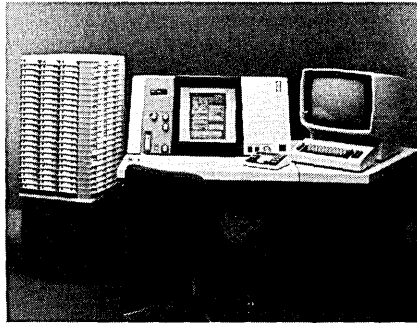

index frame may be needed frequently.

Both units can communicate synchronously or asynchronously using

ASCII or EBCDIC characters. The units can be switched to be compatible with IBM 3277 display terminal protocols, or asynchronous data transmissions at standard rates ranging from 50bps to 9600bps. Both RS232 and 20mA current loop interfaces can be used. The IMT-100 sells for \$8,855, while the IMT-150 goes for \$9,955. EASTMAN KODAK CO., Rochester, N.Y.

FOR DATA CIRCLE 388 ON READER CARD

VIDEO INTERFACE BOARDS

The CRT-2000 and CRT-3000 are 16-line by 64-character video interface boards that communicate with digital devices (computers, ASCII encoded keyboards) via a parallel TTL interface. The boards generate video output signals compatible with monitors using RS170 inputs. The boards have 1K-characters of RAM and a PROM-driven character generator. Cursor functions, foreground/background video, protected fields, and automatic scrolling are standard. The CRT-3000 offers one additional feature not found in the CRT-2000: it has a "screen read" feature that allows random access reading of any character position on the screen. In singles, the CRT-2000 sells for \$149.95, the CRT-3000 comes in ten bucks higher at \$159.95. NUCLEONIC PRODUCTS CO.,

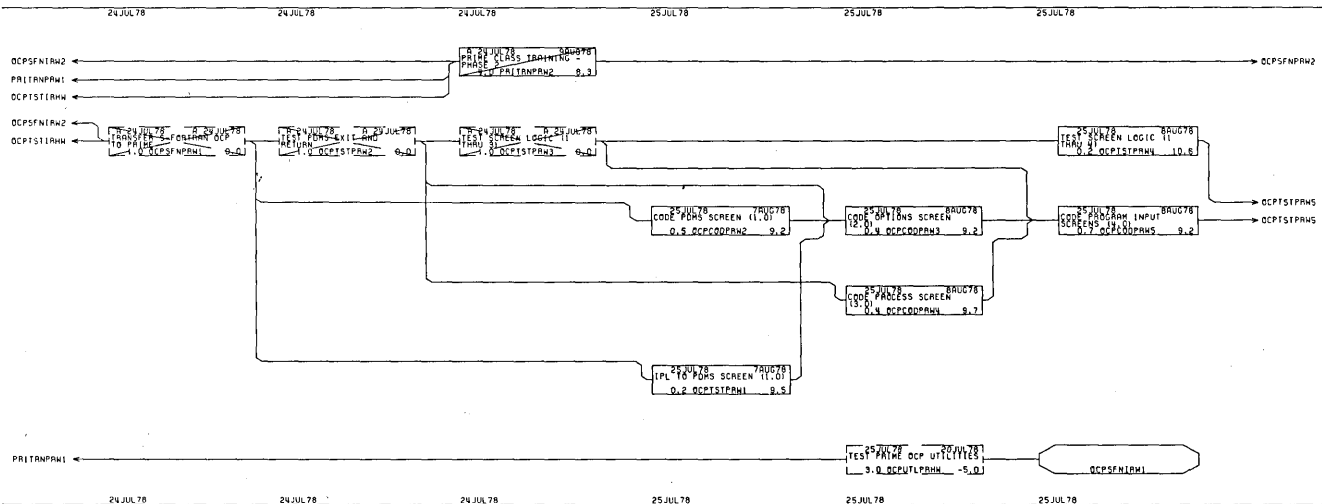

PROJECT MANAGEMENT

After ten years of selling EZPERT, a graphic output package for use with a variety of project management packages running on large mainframes, this vendor has taken the step into the turnkey system market. The Vision system combines EZPERT's capabilities with management software for planning, scheduling, monitoring, and controlling projects. The vendor hopes this turnkey approach will reach smaller firms, particularly those that don't have a computer capable of running EZPERT and one of the many project management packages offered for mainframes. Installing a Vision system should allow smaller firms

to compete with large outfits for government contracts stipulating detailed management reporting.

The system's management software encompasses planning and control of cost, schedule, and resources. Integrated reporting and financial accounting also are included. Graphic outputs include networks, Gantt barcharts, X-Y graphics, task charts, and logic networks.

The Vision family comprises three members: Vision 1000 (with deliveries targeted for next March), Vision 3000, and Vision 7000. The latter two are planned, but completion dates have yet to be set. Vision 7000 is intended to satis-

fy the Dept. of Defense's instruction 7000.2, which specifies a wide range of detailed reporting capabilities that a contractor must possess to be considered for certain government contracts.

Vision systems are implemented on Prime computer systems. Vision 1000 consists of a Prime 300, 12MB (6MB removable, 6MB fixed) of disk, terminal, Printronix 300 lpm dot-matrix line printer (with graphics capabilities), and, of course, the software to make it all work. The system will sell for roughly \$100,000. A Versatec electrostatic plotter will be offered as an option. SYSTONETICS, INC., Anaheim, Calif.

FOR DATA CIRCLE 383 ON READER CARD

What will you do with all the space Magic Aisle® saves you?



Add an office?
Enlarge a room?
Widen a hall?
Or triple your filing capacity?

Let's face it. Conventional filing cabinets and open shelf units waste space. Lots of it that could be put to better use. That's reason enough to consider Acme Visible's Magic Aisle high density filing system, with 5 second access.

Magic Aisle's compact mobile shelving is secured on floor-mounted tracks—until you press a button. Then the Magic Aisle lights up and slides open where you wish entry. In seconds, you have two-way access to computer reels, microforms, print-out reports, binders and books, small parts, insurance policy/claim folders, purchasing/inventory master

files, or any combination of record formats. Add color-coded KromaKode® folders to find files even faster and end misfiling.

With up to eight adjustable tiers on each side, Magic Aisle utilizes every cubic foot of space available! So you can control up to three times as many records in the same space.

Acme Visible offers the Magic Aisle in five manual, mechanical and motorized systems. Whatever system you select, you'll get the strongest, all-steel carriages for long-life, the largest track for flexibility, and Acme Visible service for dependability.

Write for our free booklet today. It's filled with space and time-saving ideas that can save you money and substantially increase efficiency.

Canadian Sales: Acme Seeley Limited, Highway 17,
Renfrew, Ontario, Canada. Office in Principal Cities.
MA-77R

ACME VISIBLE Infocenters

We Simplify

Acme Visible Records, Incorporated, Crozet, Virginia 22932

HARDWARE

Canoga Park, Calif.

FOR DATA CIRCLE 389 ON READER CARD

MICROCOMPUTER MEMORY

While the manufacturer says its RAM III memory boards are specifically intended for use in its VDP line of desktop computers, the boards' S-100 bus interface should allow use in a variety of microcomputers. Available in 32KB and 64KB capacities, the dynamic memories include on-board refresh circuitry. Refreshing is said to be synchronized with the cpu's timing, occurring when the cpu is not accessing memory. The boards have an average access time of 375nsec, and a cycle time of 500nsec. The 32KB board retails for \$895; the 64KB board is \$1,695. IMSAI MANUFACTURING CORP., San Leandro, Calif.

FOR DATA CIRCLE 390 ON READER CARD

CONTROL INTERFACE

For control applications, the RS-16-1 can drive 16 medium-power loads, such as small dc motors or relays, and sense 16 switch contacts or TTL inputs. The controller attaches to a microcomputer via an eight-bit parallel I/O port. Output lines can be individually set or cleared by programs issuing I/O commands. Relay, switch, and logic connections to the RS-16-1 are made through a single removable connector, which leads to an interesting troubleshooting scheme. If the unit fails, the user can plug in a special connector which wires the unit's output into its input. Then a diagnostic BASIC program exercises the unit, identifying the part or parts which have failed. The RS-16-1 sells for \$229, including an installation guide and sample BASIC programs. COOPER COMPUTING, Clayton, Mo.

FOR DATA CIRCLE 391 ON READER CARD

MINIFLOPPY SUBSYSTEM

The FDS-100 Minifile is an intelligent minifloppy disk subsystem with a file management system in firmware. Of the four models in the family, two are intended to interface to instruments, and the remaining two sport computer interfaces. The file management system handles file creation and deletion, directory maintenance, diskette formatting, and file repacking. Three of the four models have integral keyboards for issuing commands to the file management system, while the fourth accepts ASCII command strings from its host. The FDS-100 Minifile model S, intended for program loading and data storage, is commanded by the host via an RS232C, RS422, RS423, or current loop interface. Model 11K is intended as a paper tape replacement for PDP-11's. As such, it is software compatible with the PC-11 reader; it also has a front panel command keyboard.

The model SK, intended for instrumentation applications, shares the features of the model S, except it takes its commands from a front panel keyboard. Model GK has an IEEE-488 instrument interface capable of functioning as listener or talker. Model 11K sells for \$1,795; the remaining three each are priced at \$1,595. Oem discounts are offered. GRECO & ULRICH COMPUTER PRODUCTS, San Diego, Calif.

FOR DATA CIRCLE 392 ON READER CARD

PDP-11 MEMORY

The PM-S1164A packs 128KB of memory on a hex board, along with the circuitry for parity generation and checking. It's a direct replacement for DEC's MS11-JP memory board, and its associated M7850 parity controller. The PM-S1164A lists at \$4,045, and quantity discounts are offered. Depopulated boards with 32KB, 64KB, and 96KB capacities also are available. PLESSEY PERIPHERAL SYSTEMS, Irvine, Calif.

FOR DATA CIRCLE 393 ON READER CARD

COMMUNICATIONS CONTROLLER

The DCU/200 is a programmable communications controller for use with Novas and Eclipses. Occupying the middle tier of a cpu/controller/multiplexor hierarchy, the DCU/200 handles character I/O processing, improving the host's efficiency by allowing it to use message-oriented I/O. The DCU/200 has 4K-words of 400nsec memory, and the capability of accessing the host's memory (beyond the 4K local address space). The single-board controller occupies one slot in the host and interfaces to the host's DMA channel. A host can support up to four DCU/200s. Each DCU,

in turn, can have as many as 16 multiplexors connected to it. The multiplexors can be either 8- or 16-channel asynchronous units, or 2-channel synchronous units. The DCU is supported by software for asynchronous, synchronous, and bisync protocols; it can be programmed for other protocols as needed. Three host operating systems—AOS, RDOS, and RTOS—provide support for the DCU/200. DCU/200s sell for \$3,900, in unit quantity. DATA GENERAL CORP., Westboro, Mass.

FOR DATA CIRCLE 394 ON READER CARD

FLOPPY CONTROLLER

Oem's and end-users of LSI-11 and LSI-11/2 microcomputers can use the FDI-L11 to control up to four full size and three mini-floppy drives simultaneously. The floppy disk controller also contains a PROM-based bootstrap which can load an operating system from diskette at power-up. The FDI-L11 handles single- or double-sided drives from the Shugart SA800/850 and SA400/450 families (or equivalent). It is said to handle all soft-sectored formats with 16 bytes to 4KB per sector. Data transfers are via direct memory access; a DMA control is included in the FDI-L11. A single controller sells for \$945, with quantity discounts offered. COMPUTER TECHNOLOGY, Oakland, Calif.

FOR DATA CIRCLE 395 ON READER CARD

CRT TERMINAL

The TVI-912 crt terminal should appeal to economy-minded terminal shoppers. At \$749 for one, dropping to \$595 for 5 to 49, and \$550 for 50 to 99, the TVI-912 should find favor with users needing a full function crt at a reasonable price.

HARDWARE SPOTLIGHT

INTERFACE PANEL

The C-Pad, a microprocessor-based touch-operated I/O device, looks like a nicely engineered man/machine interface, especially when the human side of the equation is heavily weighted with semiskilled and unskilled operators. The vendor says it sees the process control field as a major market; we suspect the C-Pad will find acceptance with current and potential users of touch-sensitive crt's, and crt/light pen combinations.

The unit consists of 20 touch-operated switches, associated with 20 eight-character alphanumeric displays. It has an additional 40-character single line display (sans switch) for outputting longer messages. The LED displays can represent 64 ASCII characters (the upper case alphabet, 10 digits, 28 symbols) and a cursor. The keys generate single-character ASCII codes when touched and, after a one second delay, each key will

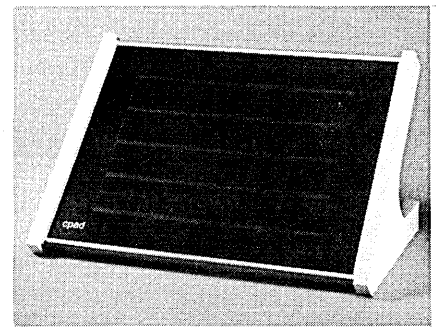

repeat its code at 0.1-sec intervals as long as the key is held. Communications between the C-Pad and the computer can be full- or half-duplex at data rates of 1200bps, 2400bps, 4800bps, or 9600bps. Interfacing may be RS232 or 20mA current loop. A single C-Pad sells for \$1,950; quantity discounts are available. CONTROL TECHNOLOGY + ENGINEERING CORP., Mountain View, Calif.

FOR DATA CIRCLE 382 ON READER CARD

The American Computer Conference



- Nov. 8
• Los Angeles, CA
- Jan. 9
• Atlanta, GA
- Jan. 24
• Hilton Head Is.
- Feb. 13
• Ft. Lauderdale, FL
- Feb. 28
• Orlando, FL
- Mar. 6
• Houston, TX
- Mar. 12
• Dallas, TX
- Mar. 15
• Phoenix, AZ
- Mar. 30
• San Francisco, CA
- Apr. 19
• Philadelphia, PA
- Apr. 23
• Hasbrouck Heights, NJ
- May 18
• Boston, MA
- May 23
• Washington, DC
- Jun. 6
• Chicago, IL

A sales tool you can count on is what is offered in a program of one day equipment displays/ seminars held in 14 different locations across the nation, aimed at attracting the most sophisticated OEM buyers of computer and peripheral products. Your products will receive the exposure you need to attract the decision-making buyers in the OEM industry. For more information call toll free 800 526-0272 or direct 201 488-7770.



American Computer Conference
c/o On-Line Hardware Inc.
65 East Route 4
River Edge, N.J. 07661

HARDWARE

The microprocessor-based terminal displays 24 lines of 80 characters (from the 96-character ASCII set) on its 12-inch diagonal screen. The unit has an addressable cursor, tabs, high- and low-intensity characters, and inverse video. On the communications side, the TVI-912



can operate in half- or full-duplex mode, with switch-selectable parity. Transmission can be either character-at-a-time or block mode, at speeds ranging from 75bps to 19,200bps. Interfacing can be RS232 and 20mA current loop. TELEVIDEO, INC., Santa Clara, Calif.
FOR DATA CIRCLE 396 ON READER CARD

VIDEO TERMINAL BOARD

The VideoTerm, Model VT-103A, provides I/O control between microcomputers using the Multibus architecture, raster scan displays, and eight-bit keyboards. Intended for use with microcomputer systems from Intel, National Semiconductor, and other manufacturers using the Multibus, the VT-103A generates 9x7 dot matrix characters from the 96-character ASCII set. The board contains its own refresh memory for 16 lines of 64 characters. An eight-bit keyboard port is included. Two video outputs are provided: composite RS420, and direct drive. A single VT-103A, including cursor control logic, sells for \$495; quantity discounts are offered. DATAcube SMK INC., Reading, Mass.
FOR DATA CIRCLE 398 ON READER CARD

PRINTER/TERMINAL

It's not such a big step, still it's interesting to note that this computer company, which started out making crt terminals 10 years ago, has just introduced its first KSR printer/terminals. Built around the existing Freedom printer line, the new terminal offerings are available in 80cps and 160cps versions. The upper/lower case ASCII dot-matrix printing terminals can print lines of up to 132 characters.

An integral bipolar processor optimizes bidirectional printing, and provides last-character visibility by spacing over whenever the print mechanism is idle. The terminals sport dual, separately controlled paper paths (with optional forms tractors), and RS232 interfaces. A choice

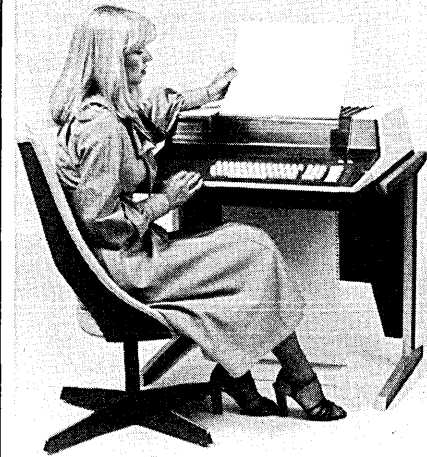

of keyboards also is offered. The 160cps model 3552 sells for \$4,895; the 80cps model 3551 is \$4,395. On a three-year lease the two go for \$165 and \$150 per month respectively; maintenance is \$55 and \$40 per month. DATAPOINT CORP., San Antonio, Texas.
FOR DATA CIRCLE 397 ON READER CARD

TERMINALS MONTH-TO-MONTH LEASE!

from the **VETERANS** in **TERMINALS** featuring
WARRANTY & SERVICE for over **10 YEARS!**

ALL LEASES: 3-MONTH MINIMUM

**LOWEST
PRICES
EVER!**

VIDEO

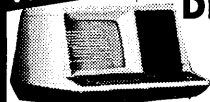

DEC VT50 HA
\$70^{MO}
 OR BUY: \$ 995

	MONTH LEASE	BUY
HAZELTINE		
1000 ... 12x80	\$ 35	\$695
1200 ... 24x80	50	750
2000 ... 27x74	70	995
3000 ... 27x74	100	1500
THERMAL PRINTER	55	795
DUAL CASSETTE	90	1395

LEAR SIEGLER "NEW"
 ADM-3A 24x80

HARD-COPY



**CENTRONICS
101A \$100^{MO}**
 OR BUY: \$1395

	MONTH LEASE	BUY
CENTRONICS		
102A ... 330 CPS, TTL	\$125	\$1895
103 ... 165 CPS, LSI	115	1695

DEC "NEW"
 LA36 DECWRITER II

OLIVETTI "NEW"
 TC480 "PT & CASSETTE I/O" —C A L L—
 TELETYPE "NEW"
 43 TELEPRINTER

"NEW" UNITS — MANUFACTURER'S WARRANTY • ALL OTHER UNITS — 30-DAY WARRANTY

★ ★ **ONE-DAY SHIPMENT ON ALL ITEMS.** ★ ★

SEND FOR OUR **FREE** TERMINAL CATALOG!
AMERICAN TERMINAL LEASING • 617-261-1100

P.O. BOX 68, KENMORE STATION, BOSTON, MASS. 02215

MINICOMPUTER

The Able family of 16-bit minicomputers has four members, differing only in standard equipment, number of chassis slots, and power supply capacity. The family uses MSI technology as opposed to LSI, due to reliability and cost considerations. The asynchronous cpu has 16 registers and is said to execute in-



structions in an average of 200nsec to 300nsec.

The family's common operating system, dubbed XPL, is a real-time operating system designed to aid in composition, editing, and compiling programs. It includes a three-pass optimizing compiler for a PL/1 subset.

The Able/20, designed for running compiled programs, consists of a

10-slot chassis, terminal interface card, real-time clock, 4KB of memory (expandable to 32KB), and a single drive minifloppy. It sells for \$4,826. The Able/40, the smallest member of the family that can be used for program development, has a 15-slot chassis, 32KB of memory, and dual minifloppies. Its price is \$7,750. Able/60 is an Able/40, with eight-inch floppies in place of the 40's minifloppies. It sells for \$9,500. The 21-slot Able/80 includes four special purpose interfaces: a 16-line, 12-bit A/D converter, a timer with usec resolution, a 32-bit TTL I/O interface, and a Hand Operated Processor which provides direct I/O access. The Able/80 goes for \$9,865. Oem discounts range from 10% on two units to 40% on 100 units. NEW ENGLAND DIGITAL CORP., Norwich, Vermont.

FOR DATA CIRCLE 399 ON READER CARD

80-COLUMN IMPACT PRINTER

Eighty columns, 84 lpm, 96 ASCII character impact printing, and an RS232 interface in a \$845 (quantity one) package? That's the DP-8010, one of three members of the DP-8000 family of printers. The 8020 and 8040 differ in interfaces, with the first having current loop interfacing and sharing the 8010's price, the latter having a parallel interface and a \$795, quantity one, price tag. All three are controlled by a microprocessor, and have 256 character buffers. The two serial interfaced units accept data at standard rates from 110bps to 9600bps; the parallel interfaced DP-8040 accepts data at up to 1,000 characters per second. The family uses a dot matrix print head rated at 100-million characters. Sprocket-fed paper can enter through either the bottom or the rear of the printer. Availability is slated for November. Distribution channels will consist primarily of oem's and distributors. ANADEX, INC., Chatsworth, Calif.

FOR DATA CIRCLE 407 ON READER CARD

FLOPPY DRIVE

The FDD 100-8 series of 8-inch diskette drives feature Shugart-compatibility, 85% parts commonality between single and dual-head drives, and double density recording without extra prewrite compensation circuits. The units also have IBM compatibility, and can read or write 3740-formatted diskettes. Single density FDD 100-8s can record up to 400KB per diskette; double-density capacity is 800KB. Options include a door interlock, hard sector detection, and write protection. Available to oem's, single quantity prices start at \$580. SIEMENS CORP., OEM Div., Anaheim, Calif.

FOR DATA CIRCLE 400 ON READER CARD

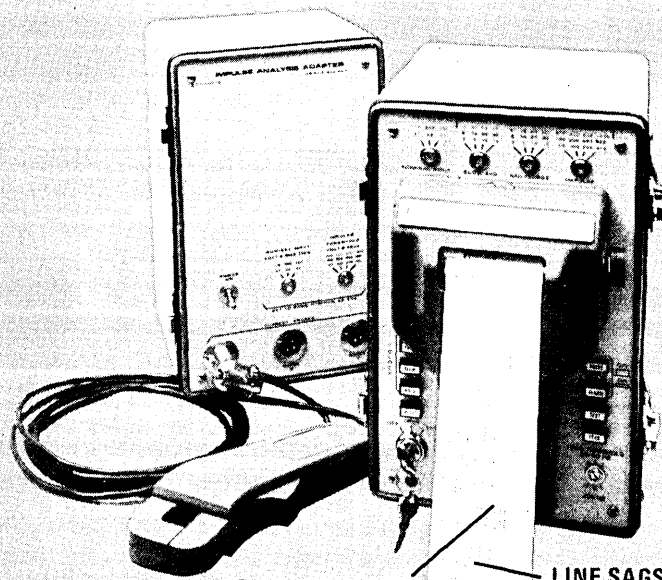

SLOW-AVERAGE
LINE CHANGES

DC OUTPUT AVG,
SAG/SURGE, TRANSIENTS

LINE SAGS & SURGES

LINE TRANSIENTS
NUMBER AND
AMPLITUDE

IMPULSE AREA
(VOLT-SECONDS)

and now... The Final Diagnostic Data!

Two years ago, we brought you the first microprocessor-based line-disturbance analyzer (Series 606) — a breakthrough design that monitored and recorded sags, surges, slow-average drifts, and impulses on AC power lines. It changed the entire computer-maintenance picture, from guessing to *knowing*. You made it the world leader in line-quality assurance. Thousands are in daily service.

Last year, we brought you a new design (Series 616), extending your diagnostic capability to monitoring both AC power input and DC power outputs, so that you could analyze the effectiveness of system power-supply regulators and filters. Once more, it swept the industry.

AND NOW we've created the ultimate diagnostic tool: a family of Impulse Analysis Adaptors that work with

Series 606 Disturbance Analyzers to give you *accurate, quantitative* measurements of *severity* of the most disturbing (and elusive) of all line disturbances: *transient impulses*. Now you can measure, classify, and print records of such disturbances, expressed in terms of *volt-seconds* (energy content) of the transient impulse.

For complete technical data on these brand-new Series 6000 Adaptors, and the Series 600 Power Line Disturbance Analyzers themselves, plus valuable application notes, use the inquiry number, or call or write: Dranetz Engineering Labs., Inc. 2385 South Clinton Avenue South Plainfield, N.J. 07080 (201) 755-7080

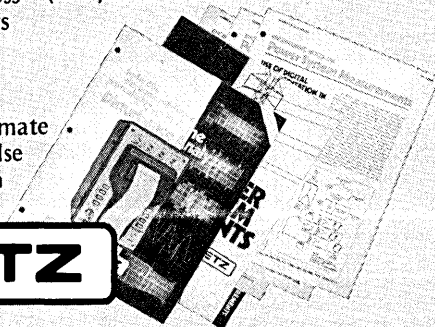

DRANETZ

SOFTWARE

UPDATES

We recently saw a demonstration of what was to us a rather surprising piece of personal computer software: a stock quotation service. Using an Apple II personal computer, and software developed by Apple, users can access the Dow Jones' Stock Quote Reporter Service via a phone link. Users get 15-minute delayed quotes on the stocks of their choice. Portfolio evaluation and access to the Dow Jones data base of news stories about the companies are in the works. The demo, held at The Computer Store in Santa Monica, was so impressive that one of the dozen or so guests, who happened to be a stock broker, was last seen sitting at the cashier's desk ordering his own system.

The SPSS and SCSS users group, ISSUE, is having a membership drive. The independent group says it "has the autonomy needed to express its members' concerns while maintaining close communication with SPSS Inc." The group picks up its mail at P.O. Box 8224, Chicago, IL 60680.

New York City is about to begin teaching math to third through eighth graders with the help of microfiche projectors from Kodak, and learning materials prepared by Educational Testing Service. Students in Manhattan's Upper West Side will answer diagnostic questions, progressing to more difficult material if they answer the questions correctly. Teachers will be able to spend time individually with students having trouble.

The Society for Worldwide Interbank Financial Telecommunications, SWIFT, officially accepted General Automation's interface device software. SWIFT now owns the package and has full responsibility for its maintenance.

PET ACCOUNTING

Personal Ledger is a double entry book-keeping system for owners of the Commodore PET. It has provisions for budgeting, and keeping records of income, expenses (both deductible and nondeductible), assets, and liabilities. As many as 50 accounts can be defined, with names and budgets specified by the user. Data are read from cassette prior to entering transactions, and rewritten to cassette after all transactions have been entered. If the user has a printer, the package can print income statements and balance sheets, as well as an audit trail of transactions. Supplied on cassette, Personal Ledger comes with a manual, program listing, and sample data. It sells for \$20. CHANNEL DATA SYSTEMS, Goleta, Calif.

FOR DATA CIRCLE 352 ON READER CARD

PROPERTY MANAGEMENT

Firms involved in real estate and property management may be interested in this package written for the IBM System/32. It's an accounting package emphasizing property management. The package was developed by a real estate firm, which has been using it for better than six months to manage better than 1,400 commercial and residential units.

The system is divided into four subsystems: cash receipts, cash disbursements, general ledger, and property management. Input comes from the keyboard, and the input routines are designed for use by nontechnical personnel. Both closing and on-demand reports are provided. Closing reports include the usual accounting reports, such as profit and loss broken out by branch and division. A rent roll, with renter data, a receipts statement, and a monthly operating statement summarizing all activity for each project are additional closing reports. Of the on-demand reports, perhaps the three most important are the availability report on units, cash receipts and disbursement statements, and a delinquency report which includes the tenant's payment history and phone number. The package carries a price tag of \$8,000, which includes five days of on-site installation and training (though the customer also

must pay transportation costs for the vendors personnel). The package carries a one year guarantee. J. ALVIN HAWBAKER ASSOCIATES, State College, Penn.
FOR DATA CIRCLE 353 ON READER CARD

MICRO SOFTWARE DUPLICATION

Here's a service that should help aspiring microcomputer software moguls: cassette program duplication for the TRS-80 and PET markets. Why is it limited to only those two machines? The vendor explains it's a matter of quality control. It has these two machines on hand, and uses them in the duplication process. Here's how it works: the software author provides the company with a cassette to be duped. The company loads the cassette into the appropriate personal computer, then dumps the program onto

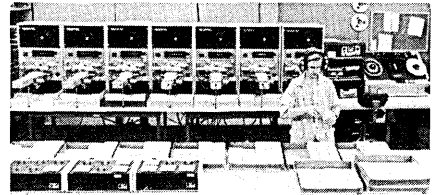

a 1/4-inch master tape. Then they use the master tape to generate the production run. And you don't have to place a big order to use the service: they'll accept an order for as few as 100 copies. For 100 copies, the price is \$1 per cassette, which includes media, Norelco-style box, unaffixed blank labels, and shipping the entire batch to any one location in the continental U.S. Turnaround on an order this size is said to be seven days. Larger volumes cost less per copy, and may take a little longer to fill (say 30 days for 100,000). MICROSETTE CO., Sunnyvale, Calif.

FOR DATA CIRCLE 354 ON READER CARD

OPTIMIZATION MODEL

The Space Shuttle Spares Optimization Model, as the name implies, was developed to predict the number of spares needed in the space shuttle project, and to help prepare budget forecasts. It also performs risk analysis on the spare stocking strategy generated. Coming down to Earth, it looks like the kind of

ASI/INQUIRY

The IMS DB/DC QUERY LANGUAGE

USED BY MORE IMS INSTALLATIONS THAN
ANY COMPETING PRODUCT



ASI/INQUIRY is an IMS DB/DC query language that operates completely as an interactive Message Processing Program. The design of ASI/INQUIRY is such that the *structure of the data base is transparent to the user*. Moreover, one need not have familiarity with DL/1 segment logic or the complexities of multi-pathing. Extremely rapid response time is assured.

MAJOR HIGHLIGHTS

- End-user oriented
 - Easy-to-use language
 - Requires no knowledge of IMS
 - Comprehensive diagnostic messages
- Rapid response time for even the most complex queries
- Dynamic priority scheduling to maximize system performance
- Availability of default as well as user-defined screen formatting

Additional features and functions include:

- Supported under both IMS DB/DC and TSO
- Full support of IMS/VS secondary indexing
- Open-ended computation facilities
- Ability to SORT display output
- Complete security through password protection
- Comprehensive log of all session and run statistics
- Unlimited data base concatenation and referencing
- Optional usage of qualified SSA's

In summary, ASI/INQUIRY represents the state-of-the-art product in an IMS/DC or TSO-supported environment. Contact us and learn why organizations such as *Hughes Aircraft, Standard Oil of Indiana, Hydro-Quebec* and *EXXON* are processing queries like "What if . . ." and obtaining a return on their investment many times over.



The Software Manufacturer

Applications Software, Inc.
Corporate Offices
21515 Hawthorne Boulevard
Torrance, California 90503
(213) 542-4381

SOFTWARE

thing manufacturers and dealers might use to keep their parts inventories adequate, but not overly large. Written in FORTRAN IV, the program runs as a batch job on 360s and 370s running OS. It requires roughly 400KB of main memory. The documentation can be had for \$8. The program itself, which the distributor calls MSC-18015, sells for \$140. COMPUTER SOFTWARE MANAGEMENT AND INFORMATION CENTER (COSMIC), Athens, Georgia.

FOR DATA CIRCLE 355 ON READER CARD

M6800 COBOL

Oem's developing business applications on M6800-based microcomputers should be happy to learn of the M6800 resident COBOL compiler. It's said to handle all of the 1974 level one COBOL constructs, plus a handful from higher levels, including the COMPUTE and SEARCH verbs, nested IF's, and complex logical conditions. It runs on the Exorciser Development System, when equipped with 32KB of memory, floppy disk system, and terminal. Compilation is said to procede at 500 statements per minute. The compiler has a license fee of \$1,195. MOTOROLA SEMICONDUCTOR PRODUCTS, INC., Phoenix, Ariz.

FOR DATA CIRCLE 356 ON READER CARD

SOFTWARE SPOTLIGHT

SPEECH SYNTHESIS

The Votrax line of speech synthesizers and the Computalker speech synthesizer both can make your computer talk. Unfortunately, neither can speak directly from English text. Someone, or something, has to translate the words to be spoken into codes specifying the phonemes (in linguistics, the smallest unit of speech; the sounds which, when combined, form spoken language). Well, Anglophone is an 8080 assembly language program that does the trick. The program is based on research published by the Navy Research Lab in Washington, which claims 97% accuracy in translating text into phonemes. That doesn't mean word accuracy; words with two pronunciations (such as "read": should it be "red" or "reed"?) cause problems. The vendor says you can work around this problem by spelling ambiguous words phonetically. Or, you could go in and

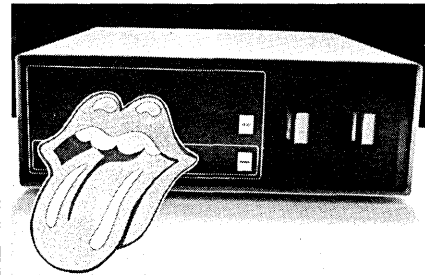

hand code those words the software can't handle. With a Votrax VS6, we're told Anglophone works in real time. There's a several second delay when using the Computalker, as additional processing is required. The Anglophone package needs 8KB of memory, and includes both source and object code on paper tape or cassette. A 120-page user's manual is included in the \$100 price. UPPER CASE BOOKS, Champaign, Ill.

FOR DATA CIRCLE 351 ON READER CARD

TEXT PROCESSING

This vendor has added software for creating, storing, and editing documents on its System 45 (aka 9845) desktop computer. The user can enter and store text on the computer, and subsequently

alter, organize, or update any of the material. Features include automatic search with replacement, and the repetition or movement of blocks of text. The software takes advantage of the System 45's function keys, which are defined to initiate hyphenation, line insertion,

YOU DEVELOP THE SOFTWARE PRODUCT.. WE'LL MARKET IT.. YOU DRIVE TO THE BANK



If you're one of those bright data processing people who has developed a sound software package, you've probably struggled with different methods of getting it to the marketplace.

We know what you've been going through. We're an established computer software company with a proven track record of bringing products to the marketplace and supporting them once they are sold.

Now we're looking for additional systems-oriented software to add to our line.

If you have developed software that is currently running at one or more computer installations, we'd like

to talk with you. We will package the product, promote and sell it, and provide the after-sale service data processing organizations deserve and demand.

It will only cost you a little time and fifteen cents to outline your package and its areas of use to us. And, it could pay you big dividends once we get together.

Drop us a note today and we'll get back to you immediately to see if there's a way we can both benefit from your expertise.

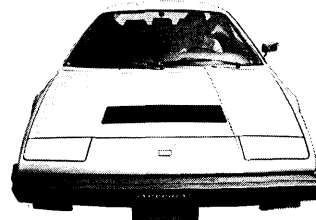

Box S-9-1
Datamation
35 Mason Street
Greenwich, Conn. 06830

margin placement, and text additions. The System 45 also can store as many as 45 pages of single spaced text on one of its miniature 3M-type cassettes. The Text Processing software sells for \$300. HEWLETT-PACKARD CO., Palo Alto, Calif. **FOR DATA CIRCLE 357 ON READER CARD**

DATA SECURITY

IBM has brought out its latest release of RACF (Resource Access Control Facility), said to be more convenient to use as a system-wide access control because it now "is easier to use with other programs." Release 3 can spread control information among storage devices, providing multiple paths and improved access to needed data. IMS/VS now can get extended security support via RACF. When used with IMS/VS, RACF allows storage of user authorization information in main memory, increasing performance. A merge/split facility can expand or reduce the number of RACF data sets. Simultaneous update and backup of RACF data sets now is possible. More than one user ID now can be maintained in a single address space. RACF Release 3 runs under OS/VS2 MVS, and is available now for \$500 per month. INTERNATIONAL BUSINESS MACHINES CORP., White Plains, N.Y. **FOR DATA CIRCLE 358 ON READER CARD**

MICROCOMPUTER COBOL

This vendor now offers COBOL for its Z-80-based microcomputer systems. Based on ANSI standard X3.23-1974, this COBOL includes all Level 1 features for the nucleus, and then some. Sequential, relative, and indexed file handling are



included, as are table handling, library, and interprogram communication capabilities. Level 2 options supported include the verbs STRING, UNSTRING, COMPUTE, SEARCH, and PERFORM. Abbreviated and compound conditions, and condition names also may be used. Data may be written to diskette in packed

decimal format, saving mass memory space. A batch style debug utility is included. COBOL is offered on two media: minidiskette (model FDC-S) or 8-inch diskette (model FDC-L). It sells for \$95. CROMEMCO, INC., Mountain View, Calif. **FOR DATA CIRCLE 359 ON READER CARD**

INTERACTIVE JOB SUBMISSION

Users of this vendor's BASIC time-sharing system for 370s can interactively build source program files (in the language of their choice) and use the Interactive Job Submission (IJS) subsystem to submit these files as jobs to the Power/VS spooler. Output can be retrieved via IJS. A text editor aids program creation, and allows retrieval of selected portions of the output. Users can include canned JCL with their submissions, via IJS's Power/VS SLI procedure support. Security facilities protect users from each other and allow the system supervisor to specify what kinds of jobs each user may submit. IJS runs as a subsystem of the vendor's BASIC/TPC. Educational users get a 25% price break, and can license BASIC/TPC for \$300 per month, and get IJS for an additional \$100 per month. Trial licenses are offered. CBM, Lansing, N.Y. * **FOR DATA CIRCLE 361 ON READER CARD**

Controls Division

CAREER OPPORTUNITIES WITH HARRIS CONTROLS IN FLORIDA

Harris Controls is a highly decentralized division of Harris Corporation, a strong and rapidly growing communications and information handling company with current volume approaching the billion dollar level. Our reputation as a leading supplier of computer-centered supervisory control and digital data acquisition systems

for the electric utility, railroad, and pipeline industries is further enhanced through expansion in Power Control Centers, and energy management systems. We offer a very challenging growth environment and all the advantages of our uncrowded Florida East Coast location—which makes living here as great as working here!

Software Design Engineers

Minimum, 2 years experience in real-time computer control applications. Engineering, computer science majors or math majors preferred. These positions offer a wide variety of duties including development of custom and standard software for use in real-time applications, development of new control algorithms and strategies, and participating in the definition of new applications for existing products. Experience with scientific FORTRAN and real-time assembly language is required.

Sr. Software Design Engineers

Minimum, 5 years experience in real-time computer control applications. These positions offer an opportunity to participate in the development, design, and implementation of major new applications for the electric utility and pipeline supervisory control market. Task leadership positions are available which encompass design and project responsibility, technical supervision of software team members as well as systems integration responsibilities. Engineering or computer science majors preferred.

Please send resume in confidence with salary history to:
R.B. Storch, Harris Corporation, Controls Division
P.O. Box 430T, Melbourne, Florida 32901



An Equal Opportunity Employer—Male and Female



The Shah's Mosque in Isfahan, Iran.

You might find yourself in Tehran

Or it might be Kuwait or Saudi Arabia or Singapore. But the important thing is to find yourself professionally. And that's what EDS World Corporation is all about.

EDS World is the International Subsidiary of Electronic Data Systems Corporation and we're looking for systems analysts, programmers and software specialists.

You'll need at least three year's experience in design, programming and implementation of large commercial applications. Since we use a variety of hardware configurations and programming languages, a wide range of opportunities is waiting.

Whatever your role, the package is a good one:

1. Competitive base salary
2. Overseas living allowance
3. Housing allowance
4. Paid life & health insurance
5. 30 days annual vacation
6. Travel allowance
7. Annual bonus
8. Pension plan
9. Stock purchase plan

But the people we want should be looking for even more. They'll want to spend weekends in Athens, Greece instead of Athens, Georgia. They'll want a job where performance is everything. They'll want their kids to taste Sophocles and Aeschylus with a closed mouth and an open mind. They'll want to ski the Alps and the Alborz. And they'll want the opportunity to build a career limited only by their own skills and ambitions.

If all that sounds good to you, you'll sound good to us. Send your resume and salary history (in confidence) or call collect.

Jim Jaros
Electronic Data Systems Corporation
7171 Forest Lane, Suite 448 D
Dallas, Texas 75230
(214) 661-6051

EDS

An Equal Opportunity Employer M/F

CIRCLE 206 ON READER CARD

PERSONAL COMPUTING

THE SOFTWARE VACUUM

In personal computing we've seen hardware companies named Parasitic Engineering, Smoke Signal Broadcasting, and Thinker Toys. We've seen computer stores named Kentucky Fried Computers, The Computer Deli, and Itty Bitty Machine Company. Computer names include PET, Gnat, Apple, and No Name. Now we shouldn't be too surprised at the newly emerging software companies with names like PET Food, Speakeasy Software, The Software Works, and The Hustlers.

These clever names do little to indicate the seriousness of personal computing software issues. The hardware now is in reasonable shape for both the home and business markets. The systems software—including simple operating systems and programming languages—is available. Both home and business markets now are limited by the need for application software.

Some applications software is available. In the small business area, software falls primarily into two categories: standard and specialized. Among the standard packages are: general ledger, inventory, word processing, and data base management. A number of companies offer these. Among the more specialized packages are: medical professional billing, statistical analysis, rental locator service, rent accounts, sales order processing, and medical billing. Typically, each of these is offered by one company for one computer. Prices vary widely. For example, one general ledger package is advertised for \$35; another for \$995.

Still we have only barely started to produce the software needed to realize the promise of the personal computer. We need programs for every small business. We need consumer software collections as vast as our present stereo record collections.

Where will we get the low-cost mass-produced application software to go with low-cost computers? Will it come from the manufacturers? Will it come from the computer stores? Will we create an ad hoc structure of systems houses, consultants and software companies as did the minicomputer industry? Will book and magazine publishers get even further into the software business? Will a software distribution business analogous to the publishing business emerge? Will programming be easy enough that the user can do it?

Let's take a look at the manufacturers. The personal computing hardware manufacturers are just like their predecessors that manufactured larger computers—they just want to produce iron. They definitely don't want to be in the application software business.

Will personal computers go the way of minicomputers with software being produced by an ad hoc assortment of systems houses, consultants, and software companies?

The current rumor in the industry is that all the major manufacturers of business personal computing hardware are looking for or developing basic business applications such as accounting packages and word processing packages. Although we probably can expect some basic business applications software from the manufacturers, they will certainly not get into the specialized lower volume business applications such as packages for personnel agencies or savings and loan companies.

Now let's look at computer stores. Computer stores are in a prime position to produce software because they are in touch with the customers and their needs.

There are several examples of computer stores that have developed application software. For example, COMPAL, a computer store in Studio City, California, has produced a word processing package, an accounting package, and a real estate investing package. My store, the Micro Store in Richardson, Texas, offers a word processing package and a package for a

savings and loan company. The Computer Mart of New Jersey in Iselin, New Jersey, offers a personnel agency package. Although there have been isolated instances where stores have produced their own software, most computer stores agree that they don't want to get into the software business either.

What does that leave? Will personal computers go the way of minicomputers with software being produced by an ad hoc assortment of systems houses, consultants, and software companies? Possibly. A number of consultants and software companies are emerging. The most successful of these is probably Michael Shrayner Software in Glendale, California. Michael Shrayner markets a word processing package called the Electric Pencil II. The Electric Pencil II runs on more than 50 different hardware configurations. It is sold primarily through computer stores. The cost of the Electric Pencil ranges from \$100 to \$175 depending on the configuration. Another company called Structured Systems Group offers a general ledger package, a sorting package, and an accounts receivable package. The Software Works, Inc. offers a mailing list program called the Mail Room and an inventory program.

What is the role of the publisher in filling the software vacuum? Most of the personal computing magazines publish program listings. *BYTE* has experimented with distributing software on the printed page as bar codes which requires a simple ocr wand to read it into the computer. This is a very inexpensive means of reproducing software; however, it requires that all computers have the wand attachment. *Interface Age* magazine has experimented with distributing software by inserting in each issue a floppy ROM, a 33 $\frac{1}{3}$ rpm record much like the records that came on cereal boxes. *Interface Age* has proposed a standard for recording software in this format. *Creative Computing* and *Kilobaud* both recently went into the software distribution business. Both advertise that they will pay royalties on contributed programs and will sell the programs on cassette tapes for the Radio Shack and Commodore PET computers at a very low cost, typically

The Place To Be

Oregon is a very special place, with a pace and a flavor that can be found nowhere else.

We are proud of our home state.

It offers a pleasant alternative to the pressures of a crowded megalopolis.

It is also a place to discover new horizons in personal and professional development. At our

R&D and manufacturing complex in Beaverton, we are continually testing

the limits of technology in electronic instrumentation, graphic computing systems, and computer peripherals.

We chose to build an electronics community in Oregon for a very special reason.

Our motive is people.

Creative men and women who can help us continue an exceptional growth program, and a commitment to excellence.

Tektronix and Oregon. THE Place.

If you have the technical or marketing skills

we need, contact us.

Professional Placement, TEKTRONIX, INC.,

P.O. Box 500, 9D,

Beaverton, Oregon 97077.

A full color print of this scene is available at no obligation. Just drop a note to

Bill Eppick at the above address.

An Equal Opportunity Employer

Tektronix[®]
COMMITTED TO EXCELLENCE

PERSONAL COMPUTING

under \$10. *CURSOR* magazine is actually a monthly cassette tape containing programs for the Commodore PET. Twelve issues are available for \$24. A magazine called *The Software Exchange* has offered to publish paid classified advertisements for both needed software and for for-sale software—the idea being to match the producer with the consumer.

An enterprising company called Micro Systems Services in Orange Park, Florida, advertised a Dial-a-Program service on a toll-free number. The strategy was to transmit programs for a Radio Shack TRS-80 over the telephone receiving it using a standard telephone pickup connection to an audio cassette recorder. The service was discontinued after they discovered they couldn't transmit the programs reliably. The company is now offering software through a publication called *Dump*

The strategy was to transmit programs for a Radio Shack TRS-80 over the telephone . . .

magazine which includes a 33 $\frac{1}{3}$ rpm record similar to that pioneered by *Interface Age* magazine.

Some software appears in book form. For example, Scientific Research in Key Biscayne, Florida, offers seven books (ranging in price from \$9.95 to \$49.95) containing listings of BASIC programs. Among the programs are personal bookkeeping, games, programs for math and engineering, programs for plotting and statistics as well as a chess program. Another book publisher, Osborne and Associates, has a book called "Payroll with Cost Accounting" which contains complete documentation as well as the source program listings for a payroll package. Adam Osborne says his company sells more than 1,000 copies of this book per month. Scientific Research and Osborne and Associates take opposite approaches to the problem of software theft. Scientific Research has had such problems with copying that they are offering a reward leading to the arrest and conviction of anyone reproducing their software in any form (book, diskettes, paper tape, cassettes, records, etc.). Osborne and Associates, on the other hand, offers the software free and allows reproduction of it. Once a magnetic recording of the software has been made by keying it manually from the book, the software can be copied, given away, sold, etc. If a person doesn't desire to manually key the programs himself, he can purchase the magnetic media for any of several machine configurations. Adam Osborne says that he can afford to give

New Jersey to the customer in Texas books. In his opinion, for every software package given away, several books are sold. His books are protected by copyright, therefore, his investment is safe. Giving away the software in order to sell books is certainly a novel approach. Will software become a loss-leader for the publishing company? Will the software be the razor and the books the blade?

A software listing in a book or a magazine is a software kit. You have to put it together by keying it into the machine and debugging it. In my opinion, the software in a book is a stopgap measure and the market for these books will diminish when the real assembled software is available. Just as the market for hardware kits has diminished now that low-cost fully assembled computers are available, software kits too will have a limited life.

Can the user (businessman or consumer) do his own programming? Although the business user could learn to write BASIC programs, it is unlikely that most will want to learn programming and systems analysis to the extent necessary to implement small business systems. Most business users will want to buy packaged software that may require customization by a consultant. On the home front, there is an upper limit of about one million people who would be willing to learn to program as programming languages stand today. If home computers are to be sold to more people than this in the near future, then a very large number of package programs will be needed. In the long range future, most people probably will program in languages very different from those we know today.

Now let us summarize the present state of affairs in personal computing software. Some software has been produced by manufacturers, computer stores, consultants, and software companies. In general, the software has not been made widely available. How do we get the personnel agency package developed by a computer store in

away the software because it sells the who wants to run it on a different machine?

Figure 1 shows a possible structure for a mass market software industry. This industry structure is based on the concept of the software distribution company. The software distribution company works much like a publishing company or a music distribution company. A program is produced by a programmer just as a manuscript is produced by an author. The software distribution company evaluates the program, maps out a business plan, makes the program into a product, markets and distributes the program and provides after-the-sale support to both the retailer and the end user. The programmer receives a royalty on sales.

The first task of the software distribution company is to evaluate programs that are presented to it. The evaluation of a submitted program involves determining the potential market for the application as well as estimating the cost of turning the program into a product.

After the initial evaluation phase, a business plan must be prepared for the program product. The market must be identified and sized. The cost of making the program into a product and marketing the product must be estimated. A price must be determined for the program. The product must be evaluated against competitive products. Earnings over time must be estimated and a contract must be negotiated with the author.

Making a program into a product may require completely rewriting a program or may simply involve cleaning up the existing program. The program must be thoroughly tested. End-user documentation and documentation for the retailer must be written. Packaging for the product must be designed. It may be that conversion to other computers is required.

Marketing a program product is one of the most important tasks of the distributor. First, the buyer must be

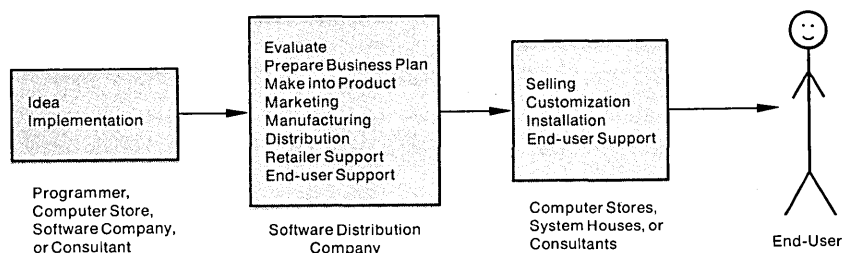

Fig. 1. Key to this industry structure is the concept of a software distribution company. Working much like a publishing company or a music distribution company, the software distribution company turns the programmers "manuscript"—his program—into a fully supported product.

This conference is being organised for representatives from commerce, industry and government, who have a vital interest in the costs and conditions of international data communications.

Data regulation in the form of privacy legislation either exists or is imminent in most European countries. Also the Third World is becoming increasingly sensitive about dependence upon US based computer systems.

The upsurge in transnational data traffic is causing considerable alarm and several international organisations are now working on regulatory plans. Barriers to computerised data crossing national boundaries are being erected in the name of privacy, data security, sovereignty, or to protect domestic data processing.

The problems are with us now even though there is as yet comparatively little awareness of them. One thing is certain, they will not go away, they will only proliferate. This conference will analyse the problems you are facing and provide you with information invaluable for the planning of future international activities.

An international programme of speakers, second to none, has been drawn together for the event. It comprises 36 key individuals from the Third World, Europe and the United States. Experts such as:

H - P Gassmann

OECD, Paris

Jan Freese

Swedish Data Inspection Board

Frits Hondius

Council of Europe, Strasbourg

Louis Joinet

Ministry of Justice, Paris

Ricardo Saur

CAPRE, Rio de Janeiro

Rudolf Schomerus

Federal Data Commission, Bonn

Gerhard Stadler

Federal Chancellery, Vienna

Henry Geller

US Dept. of Commerce

F A Bernasconi

Intergovernmental Bureau for Informatics,
Rome

For a brochure giving full details of the conference and its list of speakers, contact Online Conferences Ltd. C/o The Wayne Smith Company, Suite 810, 500 12th Str. SW, Washington DC 20024. Tel: (202) 484 5620.

Data Regulation

European & Third World realities

International Conference
28 - 30 November 1978, New York

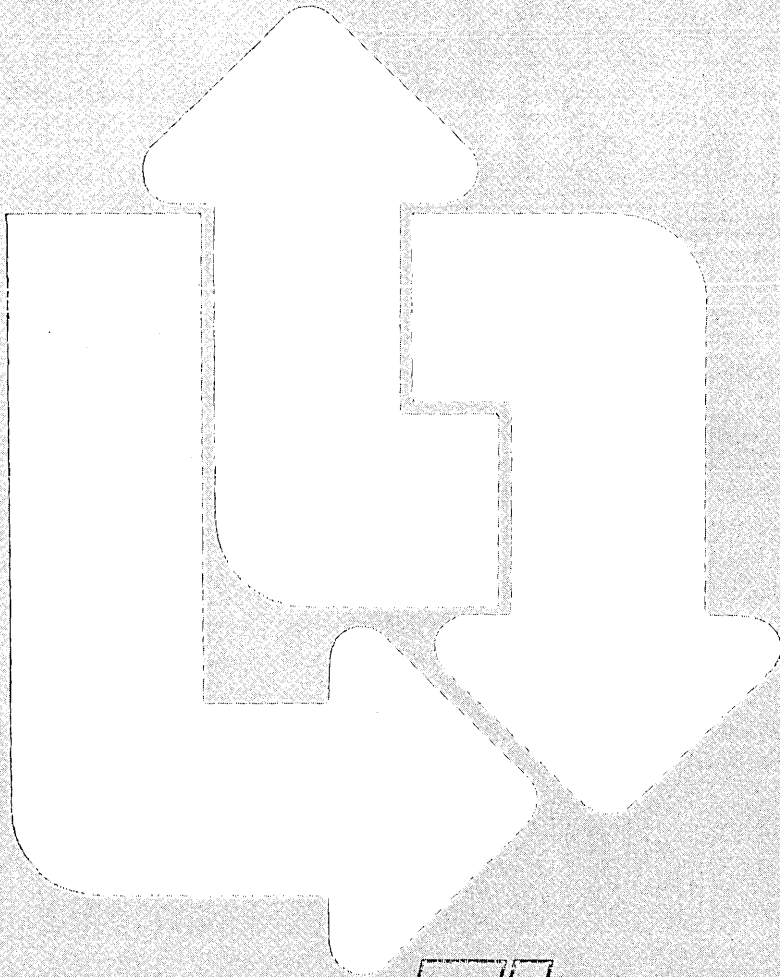

Online

Online Conferences Ltd
Cleveland Road, Uxbridge
England UB8 2DD

You're in charge of your company's information management systems, you've got some good efficient systems in operation, and you're developing others...

Yet, almost every day things are happening — hundreds of suppliers are turning out new technologies, new procedures, new applications — which can make your present systems obsolete in terms of effectiveness and productivity.

On top of that, senior management is demanding new systems for both the computer room and the office — and the integration of all information management systems.

You could spend weeks — perhaps months — seeing suppliers' salesmen, trying to find out which of the new products, which of the new applications, are right for your company. Obviously, this is a luxury you can't afford. Nobody can.

But how do you select the companies that you really want to see, the ones that have exactly what you need? Where do you find the latest ideas, the latest applications for information management?

The answer, of course, is at INFO 78 — International Information Management Exposition & Conference. In just a few days at the Show you can make a complete survey of new applications, new products, by the country's leading suppliers of information management equipment. At the Conference, you can tune in on the best thinking on what is happening — and what is going to happen — in information management, information technology, and office automation.

THE INFO 78 EXPOSITION: 200 EXHIBITORS

It's the only Show oriented towards results, rather than equipment; on solutions, rather than hardware. The emphasis is on applications, and more applications, and more applications. Of course, the equipment is there. You can see, compare and evaluate the products of more than 200 leading companies. INFO is the only Show that covers the complete range of products used in data processing, word processing, data communication and office automation.

THE INFO 78 CONFERENCE: 183 SPEAKERS

The emphasis at the Conference is on practicality — what makes for successful systems — and why some systems fail. The speakers are the leading authorities on information management in the country. With 183 speakers and chairmen, the INFO 78 Conference is the largest, most important information management meeting in the world.

HOW DO YOU KEEP AHEAD OF THE INFORMATION REVOLUTION?

FOR COMPLETE DETAILS,
CALL
800-645-6122



The Fifth International
**INFORMATION
MANAGEMENT
EXPOSITION
& CONFERENCE**

McCORMICK PLACE, CHICAGO
October 16-19, 1978

Management: Clapp & Poliak, Inc., 245 Park Avenue, New York, N.Y. 10017

Insurance Systems

Dyer, Wells and Associates, specialists in system development and project management services, has clients in the major insurance and financial centers of the eastern United States and Canada. Several opportunities are currently available for individuals experienced in group/individual or pension systems. These positions offer exceptional potential for technical, professional and financial growth. They also offer considerable challenge to self-motivated individuals who enjoy a relatively unstructured professional environment. Often the greatest reward is the opportunity to work with other talented individuals in the creation of leading-edge solutions.

Necessary Background

In addition to insurance systems experience a strong background in one or more of the following areas is necessary:

- Recent large system (excess of \$1 million budget) project leadership.
- Minicomputer hardware/software evaluation and minicomputer/communication based system development.
- Cost/benefit analysis and feasibility study preparation.
- Large scale IBM 370 based online system design and development.
- IMS DB/DC design and/or programming.
- Word Processing system integration.
- Advanced business or technical degree is desired, but not required.

Available Positions

- Project Leaders
- System Designers/Architects
- System/Hardware Analysts
- Programmer/Analysts

The Opportunity

Salary and other benefits are exceptionally attractive. All positions offer high visibility to top management levels of client companies and the opportunity for advancement within a small, rapidly growing professional organization. For more information please mail (confidential) resume, with salary history and statement of career objectives, to:

dw&a dyer,
dw&a wells &
dw&a associates inc.

6520 Powers Ferry Road Atlanta, Georgia 30339 Attn. Ms. Candis Rogers

CIRCLE 205 ON READER CARD

Assistant Vice President/ Software Development

The top post for direction of software development for a major computer systems manufacturer.

You will assume corporate leadership of software planning, development, and management for all divisions of a full-line computer manufacturer, reporting to the vice president of corporate R&D. Under your direction will be all software research, design, standards, quality maintenance, and staffing activities for a multi-million dollar program.

You will head a staff of specialists, including managers responsible for establishing policies and strategies for development of software for new products and applications, design compatibility, standards management, time and cost schedules, resource and scheduling requirements, staff recruitment and training.

Above all, you will set up an aggressive, fully supported research program, calculated to lead the field in discovery and application of new software concepts. Your work will not only guide the course of this company, but should be of such significant advancement that it can influence the industry.

Obviously, we are seeking the person who is in the front rank of the software profession. The salary and supplements are fully commensurate with the primary importance of the post.

Please communicate in confidence to Datamation Magazine, Box DM 9781, 35 Mason St., Greenwich, CT. 06830.

An Equal Opportunity Employer

PERSONAL COMPUTING

identified and the advertising program planned ads must be designed and placed. Direct mail to computer stores, systems houses and consultants may be useful to identify dealers for the program product. Trade show demonstrations may attract both dealers and end-users. Seminars might be given for both dealers and end-users. Dealer visits may be necessary. Shared advertising or direct mail to end-users with retailers may be desirable.

The manufacturing process is relatively simple for software. If the media is disk or tape, only a simple copying process is required. If the media is a read only memory in a cartridge, some assembly may be required. In any case, copies must be tested to determine that a correct copy has been made.

Actual distribution involves accepting and shipping orders and doing all the necessary record keeping. This involves determining various discounts to retailers based on volume, serial numbering the copies in order to help prevent theft, recording the number of copies shipped in order to pay the producer of the software the proper royalty, and invoicing the dealer.

Supporting the retailer is one of the most important functions of the

Supporting the retailer is one of the most important functions of the software distribution company.

software distribution company. Retailer support will require educating the retailer in demonstrating the software package by visiting the retailer periodically and providing seminars. Constant telephone help must be available. The retailer must be promptly notified of any error or change in the software, probably via a newsletter.

Even though the retailer will provide a significant amount of end-user support, the software distribution company also must provide some end-user support. Each user will be registered with a unique number. The number will entitle the user to a certain amount of telephone support and a newsletter which keeps the user updated on problems in the software or new releases. This may be paid for by a software maintenance contract. For a user willing to pay for on-site support and possibly customization of the software, it should be provided by the distribution company.

The software distribution company really makes sense. First, let's look at it from the point of view of the producer of the software. It gives the producer a wider market, it removes the continuing commitment to support the

software product, and it provides the producer with a continuing income. The producer can count on the well-known name of the software distribution company to help market his product. A producer of software might have some objections to the concept of a software distribution company. He might naively believe that he will want to perform the distribution job and keep all the profits for himself. He might also prefer the independence and complete control that he has over his software product as long as he owns it entirely. Although the author of the software need not give up to the distribution company his right to continue marketing his own product in his own territory, he might feel that he is diluting potential future territory by giving the distribution company the right to also sell the software in territories out of the producer's primary area.

From the computer retailer's point of view, the software distribution company offers many advantages. The primary reason the retailer needs the software distribution company is the impossible evaluation and selection problem facing him without it. In fact, now when a retailer looks at the marketplace and scans the magazines for advertised software and sees six different accounts receivable programs advertised, he has absolutely no idea which one to stake his future on. He certainly does not have the time to buy and evaluate every package. Further, he cannot afford to risk the chance that an unknown company might not provide the level of support required. The retailer would risk being stuck with supporting the product himself if he sold it to a customer and later found that continuing support was not available from the producer.

Many problems face the software distribution company. There is the question of whether or not the present copyright laws are sufficient to protect mass distributed software. There is the present state of the hardware market in which no one machine is clearly dominant, therefore, there are no standards for languages and software recording media. Until such standards exist, it will be necessary for a software distribution company to support a software product for a wide range of machines, languages, and media.

Is the software distribution company the answer to the software vacuum? Maybe. Time will tell. *



DATA PROCESSING PROFESSIONALS TAKE THE BULL BY THE HORNS. WE DID.

A revolutionary concept. Aggressive marketing. Far-sighted management. Strong, progressive information systems. With these weapons, Iowa Beef rose to unquestioned leadership in the beef industry . . . and is aiming for even greater success. Right now, we're looking for creative, ambitious Data Processing professionals who can capitalize on the unlimited potential of the future and grow with us in these positions:

SYSTEMS ANALYSTS:

As a member of our systems development group, you'll play a significant role in the on-going development of new business systems. A degree strengthened by at least 3-5 years experience emphasizing the design of on-line data base systems will qualify you. A manufacturing systems background is a definite plus.

PROGRAMMER ANALYSTS:

The qualified candidate possess a minimum of 2 years COBOL programming experience and at least 1 year in systems design including team leadership responsibility for major system development.

PROGRAMMERS:

A minimum of 2 years COBOL experience on large scale hardware will qualify you for this challenging, growth-oriented position.

We offer an excellent salary and full benefits including profit sharing and cash bonus. So if you're ready to take the bull by the horns, come to Iowa Beef—where your skills are challenged and your achievements recognized. Send your detailed resume with salary history and requirements, in strictest confidence, to: Walt Maciag, Manager Professional Employment, IOWA BEEF PROCESSORS, INC., P.O. Box 3350, Sioux City, Iowa 51101.

ibp IOWA BEEF PROCESSORS, INC.
An Equal Opportunity Employer M/F

OR CALL COLLECT 402/494-2061

CIRCLE 210 ON READER CARD

COMPUTER PROFESSIONALS

You'll like working at
Lockheed in Sunnyvale
on the San Francisco Peninsula

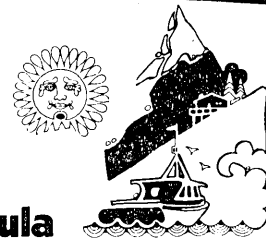

This is an excellent time to investigate the many opportunities available at Lockheed Missiles & Space Company on the beautiful San Francisco Peninsula. We're moving forward with talented professionals dedicated to meaningful programs.

Investigate the following opportunities available
at all levels, entry to senior level:

- Data Processing Analysts
- Data Systems Programmers
- Scientific Programmers & Analysts
- Software Specification Writers
- Software Architects
- Environment Generators
- Test Planners
- Configuration Controllers
- Hardware Configuration Planners
- Mission Planners
- Algorithm Definition Specialists
- Documentation Specialists
- Display & Console Designers
- Information Retrieval Systems Analysts

For immediate consideration, please forward your resume to Professional Employment, Dept. DM-978, P.O. Box 504, Sunnyvale, CA 94086. We are an equal opportunity affirmative action employer.

LOCKHEED
MISSILES & SPACE COMPANY

CIRCLE 212 ON READER CARD

advertisers' index

SOFTWARE SERVICES

Allen Services Corporation	302
A.P. Publications Ltd.	302
Applied Computer Research	302
Argonaut Information Systems, Inc.	304
Automated Concepts Inc.	302
BMS Computer Inc.	304
COMBUR	304
C-S Computer Systems Inc.	304
Cyborg Systems	303
DASD Corporation	303
DATAMATION	305
Dataware, Inc.	303
Digital Research	303
Duquesne Systems Inc.	303
Informatics Inc.	303
Information Processing, Inc.	305
International Systems Inc.	304
Management Science America, Inc.	305
National Technical Information Service	304
Olympic Systems Inc.	305
Plycom Services, Inc.	304
Second Source	304
Software Consulting Services	302
Software Systems Technology Inc.	305
System Support Software, Inc.	305

DP MARKETPLACE

datec Inc.	305
Holland Electronics	306
S-3 Supply Company	306
Tone Software Corp.	306

BUY, SELL, LEASE

Computer Merchants Inc.	306
D.V.I. Co., Inc.	306

PERSONAL COMPUTING

Data Analysis Systems	306
-----------------------	-----

JOB MARKETPLACE

Affirmative Action For Professional Women	306
Brown & Root Inc.	306
Catalyst Search LTD.	307
Conoco	307
E.D.P. Search, Inc.	307
Information Systems Design Inc.	307
Konrath & Associates	307
Mountain Bell	308
National Personnel Consultants	307
Parker Page Associates, Inc.	306
Personnel Research Inc.	308
Ronac Associates	307
Systemation Consultants, Inc.	308

Is structured programming working for you?	
YES	NO
Great! Our tools can make it even better for your COBOL and FORTRAN programmers.	Let us help you get started now. Our tools and seminars make structured programming natural.
<p>The SCOBOL and SFORTRAN precompilers give programmers languages that exactly parallel their structured designs. SCOBOL and SFORTRAN programs are translated into COBOL or FORTRAN to be processed by your compiler. The systems are distributed in source code form (COBOL or FORTRAN). Each includes the precompiler, a formatter, and a cross-referencer. For more information write or call</p> <p>SOFTWARE CONSULTING SERVICES 901 Whittier Drive Allentown, PA 18103 (215) 797-9690 Attn: Martha Cichelli</p>	

CIRCLE 309 ON READER CARD



ALLEN SERVICES CORPORATION

THE EXECUTOR
HIGH SPEED JOB PROCESSOR

- FOR MVT, SVS, and MVS ENVIRONMENTS
- INCREASES THROUGH-PUT BY 10% TO 40%
- IMPROVES TURNAROUND TO USERS
- REDUCES OVERHEAD CPU CYCLES BY 5% TO 20%
- EXTENDS LIFE AND UTILITY OF EXISTING HARDWARE
- NO JCL CONVERSION OR MODIFICATION
- EASILY AND QUICKLY INSTALLED
- OVER 10,000,000 HOURS OF OPERATION IN OVER 150 SITES
- TECHNICAL DETAILS UPON REQUEST



ALLEN SERVICES CORPORATION
 212 WEST NATIONAL RD.
 VANDALIA, OHIO 45377
 (513) 890-1200

CIRCLE 266 ON READER CARD

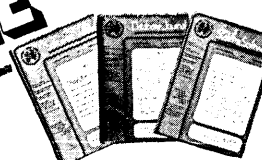

FREE

Data booklet on specialized software information systems covering:

- * **GENERAL SOFTWARE**
- * **DATABASE SOFTWARE**
- * **MICRO & MINI SOFTWARE**

A.P. Publications Ltd
 322 ST JOHN STREET · LONDON, E.C.1

CIRCLE 267 ON READER CARD

IMS EDUCATION

Automated Concepts Inc. has developed a complete curriculum of IMS training courses. Out of ACI's heavy involvement in IMS consulting services have come the experience and practical knowledge required to create this unique series of courses. The teaching method employed is an onsite lecture and workshop presentation by an ACI instructor. ACI offers the option of customization of course materials to reflect your installation's software environment, programming and operating procedures, etc.

ACI's IMS curriculum includes:

- Introduction to IMS DB/DC Systems
- IMS Programming Workshop
- Advanced Topics for IMS Programmers
- IMS Debugging
- IMS 3270 Design
- IMS Logical Data Structure Design
- IMS VSAM
- IMS Data Base Design
- IMS Reorganization, Recovery & Restart
- IMS for Operators

Send for ACI's "IMS Curriculum Guide" or contact: Rice Bullock, Education Director.

aci

Automated Concepts, Inc.
 111 East Wacker Drive
 Chicago, Ill., 60601
 (312) 565-0661

CIRCLE 270 ON READER CARD

EDP PERFORMANCE REVIEW

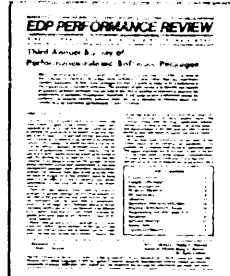

A monthly report on performance evaluation and improvement

- Tutorials
- Experiences
- Products
- Literature
- Conferences

12 Monthly Issues - \$48. per year

Includes the annual survey of performance-related software packages, plus a comprehensive bibliography of CPE literature. Write for a free sample issue

ACR

APPLIED COMPUTER RESEARCH
 P.O. BOX 9280, PHOENIX, AZ 85068

CIRCLE 268 ON READER CARD



FREE CATALOG

For a free government catalog listing more than 200 helpful booklets, write:

Consumer Information Center, Dept. A, Pueblo, Colorado 81009.

EDP Managers... You need QCM

You've tried solving your performance problems with hardware monitors, sampling software monitors, unsatisfactory billing systems, SMF and RMF inadequacies, simulators.

Now, try something that works! QCM.

QCM is the only complete system that precisely monitors all hardware and software processes, accurately bills all operations and improves performance... all on a full-time basis.

Let us show you how QCM has meant control, efficiency, confidence and dollars to our customers.

Fill out and mail this coupon or call



DUQUESNE SYSTEMS INC.

155 East Barkling
328 Fifth Avenue
Pittsburgh, PA 15222
(412) 241-8055

I'm ready to try something that works! Please provide more information about QCM.

TIME: DSV3 DVST DMVT DMFT

Name _____

Title _____

Organization _____

Address _____ Telephone _____

City _____ State _____ Zip _____

CIRCLE 289 ON READER CARD

R For A Successful Conversion



Take As Directed
For Effective
Results

DASD Corporation's NEAT/3 to COBOL Translator is fully automatic. Translator produced COBOL programs are easy to read and maintain. Conversion is accomplished quickly and effectively with significant savings in time and money.

Several service options are available: Program Conversion, Program Conversion, and Clean Compile Conversion with DASD Support and Turnkey Conversion.

DASD Corporation encourages test evaluations. Call or write today.



DASD CORPORATION
National Marketing
1180 Renaissance Drive
Suite 315
Park Ridge, Illinois 60068
312/299-5005

CIRCLE 282 ON READER CARD



VIP COMPLETES YOUR TSO
TOOL CHEST FOR MAXIMUM
PROGRAMMER EFFICIENCY

Video Programming Tools (VIP) extends your use of TSO. Test data is easily generated and modified through an interactive program module running in foreground. More comprehensive test conditions are easily produced and overall program test time significantly reduced.

JCL documentation is automatically done and always current with VIP's flowchart generator.

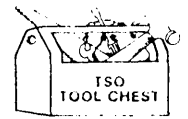

For samples, documentation and more information, contact your DASD Representative.



DASD CORPORATION
National Marketing
1430 Renaissance Drive
Suite 315
Park Ridge, Illinois 60068
312/299-5005

CIRCLE 283 ON READER CARD

RPG TO COBOL

Dataware's software translator converts RPG and RPG II programs to the industry standard ANS COBOL (DOS or OS). The translator achieves an extremely high percentage of automatic conversion (approaching 100%) of the source code.

- RPG/RPG II to PL/1
- EASYCODER/TRAN to COBOL
- BAL/ALC to COBOL
- AUTOCODER (7070) to COBOL
- COBOL to COBOL
- AUTOCODER/SPS to COBOL
- PL/1 to COBOL

For more information on our translators, please write or call today.



Dataware, Inc.
495 Delaware Street
Tonawanda, New York 14150
(716) 695-1412

CIRCLE 287 ON READER CARD

NEW Software Translators being developed at Dataware

In addition to our extensive line of conversion software and services, Dataware is constantly developing new software translators. Listed at the right are several which we are working on, or are actively considering. If you are interested in one or more of these or any additional translators, please let us know, so we can keep you informed.

The Conversion Software People



Dataware, Inc.
495 Delaware Street
Tonawanda, New York 14150
(716) 695-1412

CIRCLE 286 ON READER CARD

Please keep me informed on:

- | | |
|--|--|
| <input type="checkbox"/> NEAT 3 to COBOL | <input type="checkbox"/> DUS to OS ASSEMBLER |
| <input type="checkbox"/> COBOL to PL/1 | <input type="checkbox"/> FORTRAN to PL/1 |
| <input type="checkbox"/> PLAN to COBOL | <input type="checkbox"/> DIBOL to COBOL |
| <input type="checkbox"/> BASIC to COBOL | <input type="checkbox"/> 7080 AUTOCODER to COBOL |

Name _____ Title _____

Company _____

Address _____

City _____ State _____ Zip _____

Phone _____

Call me - I need immediate help

CP/M™ LOW-COST MICROCOMPUTER SOFTWARE

CP/M™ OPERATING SYSTEM:

- Editor, Assembler, Debugger and Utilities.
- For 8080, Z80 or Intel MD8.
- For IBM-compatible floppy discs.
- \$100-Diskette and Documentation.
- \$25-Diskette (Set of 6 manuals) only.

MAC™ MACRO ASSEMBLER:

- Compatible with new Intel macro standard.
- Complete guide to macro applications.
- \$90-Diskette and Manual.

SID™ SYMBOLIC DEBUGGER:

- Symbolic memory reference.
- Built-in assembler/disassembler.
- \$75-Diskette and Manual.

TEX™ TEXT FORMATTER:

- Powerful text formatting capabilities.
- Text prepared using CP/M Editor.
- \$75 Diskette and Manual.



DIGITAL RESEARCH

P.O. Box 579 • Pacific Grove, CA 93950
(408) 649-3896

CIRCLE 288 ON READER CARD

the choice of



ACCOUNTING IV™ GENERAL LEDGER

Our software products—General Ledger, Accounts Receivable, Accounts Payable and Standard Cost—are the choice of leaders like Fram... *not by chance, but by design.* For details, call (213) 887-9121.

informatics inc.

World's Largest in
Software Products
2105 Vanowen St. Cerritos, CA 91304

CIRCLE 295 ON READER CARD

CYBORG PAYROLL SYSTEM

The CYBORG PAYROLL/PERSONNEL SYSTEM handles multiple companies with hundreds of separate earnings and deductions. The expandable data base design allows each user to add, edit and report on as many new fields as required without any reprogramming. CYBORG provides a complete payroll system with all states, city and county taxes and complete audit and accounting reports. CYBORG has automatic check reconciliation, historical reporting, labor reports, including budget to actual comparisons with dollar and variance differences. The CYBORG REPORT LANGUAGE allows for the creation of special reports or output files (card, tape or disk) to meet your unique requirements without reprogramming. The system is written entirely in ANS COBOL and will operate efficiently on IBM, Honeywell, Univac and DEC computers.

Cyborg Systems

2 N. Riverside Plaza, Suite 2225
Chicago, Ill. 60606. (312) 454-1865

CIRCLE 279 ON READER CARD

WHY DEVELOP SOFTWARE WHEN YOU CAN BUY SOFTWARE?

What you need is a software system. What you don't need are the headaches involved in developing the system. We offer low cost systems that will work for you.

**PAYROLL/PERSONNEL
ACCOUNTS PAYABLE
TAXBREAK/TAXCOST**
(Payroll Tax Calculation Modules)

Phone us today. (415) 845-7991



argonaut

Information Systems, Inc.
2140 Shattuck Ave.
Berkeley, CA 94704

CIRCLE 269 ON READER CARD

All you IBM 370-360 & 303X users: Meet CIMS, a powerful job accounting/system performance package you can afford.

CIMS features complete charge-back system, zero-based budgeting, external charges, cost control, budget preparation, and much more.

Hundreds of satisfied users.

Rent your CIMS for only \$110/month or buy at low cost.

Call or write BMS today for details of our no-cost, no-obligation, 30-day trial.



BMS COMPUTER INC.
P.O. Box 3086
Walnut Creek, CA 94598
(415) 938-2620

CIRCLE 272 ON READER CARD

World Data Bank II

The Central Intelligence Agency (CIA) has collected and compiled a major cartographic data base containing the latest world-wide "X-Y" coordinates. Today's computer-using cartographer should find this data source essential.

World Data Bank II offers more than 5,000,000 precise digitized coordinates of:

- coastlines
- islands
- lakes
- rivers
- international boundaries
- Canadian provinces
- U.S. State boundaries

Available complete or separated into the following major subdivisions:

- North America
- South America
- Europe
- Africa
- Asia

Order World Data Bank II today.

PB-271874-SET/CPM \$675 (subdivision and other than North American continent prices on request).

Write: **NTIS** National Technical Information Service
U.S. DEPARTMENT OF COMMERCE
5285 Port Royal Road
Springfield, VA 22161

or call NTIS Computer Products Office at (703) 557-4763 for further information.

CIRCLE 303 ON READER CARD

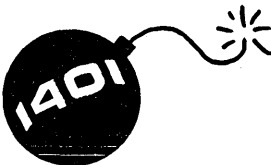

WHILE YOU'RE WAITING FOR YOUR 303X ...

Counting Down to conversion?

Why not do the whole job this time? Retire those 1400-series programs once and for all *without* losing their capabilities.

CS-TRAN converts 1400-series *object* programs directly to ANS COBOL. (All you lose is your maintenance problem.)



C-S Computer Systems Inc.

90 John Street, New York, NY 10038
212-349-3535

CIRCLE 278 ON READER CARD

OUTPERFORM PDP 11/70 FOR \$4,850

Yep. Given the same disks, memory and terminal load, a PDP-11/34 RSTS/E with GIANT/11 and BASIC PLUS can outperform a PDP-11/70 RSTS/E with RMS-11 and BASIC PLUS 2.

And the one-time \$4,850 license fee for GIANT/11 gives you DEMAND REPORTING.

You can have QUERY automatically built in to every report you write with no effort and no extra code.

AND - ISAM, MACRO SORT, DATA ENTRY, SECURITY, REPORT GENERATION AND TRAINING TOO!

Write for our Apples and Oranges comparison.

SECOND SOURCE, P.O. Box 310,
Menlo Park CA 94025.

B 1700 AND B 1800 USERS PRINTERS AND PRINTER CONTROLS

EQUIPMENT INSTALLED NOW
MORE RELIABLE—LOWER COST

COMBUR

213-378-7002
4116 VIA SOLANO 301-299-3038
P.V.E. CA 90274 604-271-6335

CIRCLE 275 ON READER CARD



How do you get Project information to the top?

PAC II

Project plans and status often have a difficult time getting from front line management up through the chain of command in a timely, consistent manner. Now there is a way not to leave that information hanging in mid-air.

PAC II is an automated project management system for planning, budgeting, and monitoring virtually any work effort.

Easily installed and used, PAC II is equally applicable in research, engineering, construction, marketing, financial and data processing departments.

International System's project management systems are serving hundreds of clients world-wide.

For more details about PAC II contact:

**International
Systems Inc.**



890 Valley Forge Plaza, King of Prussia, Pa. 19406
(215) 265-1550

CIRCLE 296 ON READER CARD

DEC RSTS/E USERS

From one of the pioneers in commercial data processing using RSTS. Off the shelf software ready for immediate delivery. Completely interactive. Extensively documented. Fully supported. Ideal for OEM's, service bureaus or end users. Cost effective solutions including:

- ACCOUNTS PAYABLE
- GENERAL LEDGER
- FINANCIAL REPORTING
- ACCOUNTS RECEIVABLE
- PAYROLL

For complete details, contact us at:

Plycom services, Inc.
P.O. Box 160
Plymouth, IN 46563
(219) 935-5121

CIRCLE 307 ON READER CARD

SELL YOUR SOFTWARE IN THE **DATAMATION** MARKETPLACE

CALL FRANCIE 203-661-5400

CIRCLE 284 ON READER CARD

MSA, IN AUSTRALASIA

MSA's Financial Software Systems are now available throughout Australasia from our branch office in Sydney.

MSA General Ledger/Financial Information & Control System
 MSA Accounts Payable System
 MSA Accounts Receivable System
 MSA Supplies Inventory Control & Purchasing System
 MSA Fixed Assets Accounting System
 MSA Payroll System
 MSA Personnel Management & Reporting System
 MSA Procurement Matching Module
 MSA Financial Forecasting & Modeling System

For more information on MSA Systems and our upcoming Financial Software Seminars in Australasia, contact Judith Lightfoot, Manager of Australasian Operations.

MSA
 Management Science America, Inc. (Limited Liability)
 15 Blue Street, North Sydney, N.S.W. 2060
 Telephone: (02) 929-0711 Telex: 23599

CIRCLE 299 ON READER CARD

MSA, NOW IN EUROPE

MSA's Financial Software Systems are available through MSA International, Inc., International Agent for Management Science America.

MSA Accounts Payable (Purchase Ledger)
 MSA Accounts Receivable
 MSA General Ledger/Financial Information and Control System
 MSA Payroll System
 MSA Supplies Inventory Control & Purchasing System
 MSA Fixed Assets Accounting System
 MSA Financial Forecasting & Modeling System
 MSA Personnel Management & Reporting System
 MSA Procurement Matching Module

For more information on MSA Software Systems and our upcoming seminars in London and Amsterdam, contact Mr. Rodger Skidmore, Manager European Operations.

MSA
 MSA International, Inc.,
 Chaussée de la Hulpe 150,
 1170 Brussels, Belgium
 Telephone: (02) 673.99.63 Telex: 63020

CIRCLE 300 ON READER CARD

NEW VERSION OFFERS

Spooling

BLIS®/COBOL SPOOLER INTRODUCES SIMULTANEOUS MULTIPLE REPORTS FOR MINIS!!

Now! A spooler specially designed for Business Systems utilizing DG NOVA's (and look-alikes). IPI's new spooler accumulates multiple reports and drives multiple printers for up to 30 users at once!

- ELIMINATES "Lost Time" waiting on printers;
- SAVES development dollars on program design;
- PRINTS reports faster, automatically, and more conveniently;
- RETAINS and files reports for future printing.

The BLIS/COBOL Spooler-IPI keeping your investment in COBOL programs competitive in today's marketplace.

Contact IPI today!

IPI
 MINICOMPUTER SOFTWARE
 1850 LEE ROAD
 WINTER PARK (ORLANDO)
 FLORIDA 32789 U.S.A.
 Telephone (305) 647-2200
 (In Fla.) 810-853-5033

CIRCLE 297 ON READER CARD

DOS TO OS CONVERSION

DOS ASSEMBLER TO OS
 DOS COBOL TO OS ANS
 DOS JCL TO OS JCL

The software converts even the most complex source code to OS. The JCL converter operates with the Assembler and Cobol Converters to automatically produce 100% of the OS JCL.

OSI offers a full line of service options for converting from DOS to OS. Software converters are available on a license basis.

OLYMPIC SYSTEMS INC.
 530 6th AVENUE
 PITTSBURGH, PA. 15219 (U.S.)
 (412) 391-1538

CIRCLE 304 ON READER CARD

DP MARKETPLACE

datec couplers connect: always

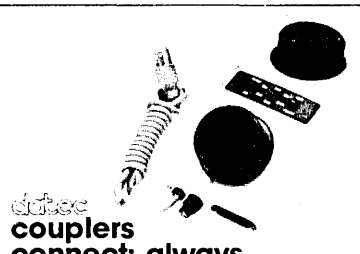

The Datec 30 Originate Only and the Datec 32 Originate/Answer acoustic couplers provide reliable Bell System 103/113 compatible Duplex or Half-Duplex, 300 bps data communication over conventional telephones. Datec's RELIABILITY THROUGH CRYSTAL CONTROL permits channel establishment with received signal levels of -55dBm or lower.

The Datec 30 and Datec 32 acoustic couplers connect, time and time again.

datec inc
 P. O. Box 839
 Chapel Hill, North Carolina 27514
 phone: (919) 967-5605

CIRCLE 281 ON READER CARD

ATTENTION: MANAGERS

Now available . . . software programs giving you complete project and administrative control over your employees' work—

- COBOL PROGRAM MANAGER**
 automatically generates program documentation and displays vital statistics pertaining to the source program
- MANPOWER ANALYSIS**
 provides weekly reporting of labor hours worked, equivalent manpower utilized, overtime analysis, and overall work summary

By investing only \$450 for each program, you will easily determine WHO is doing WHAT.

Software Systems Technology, Inc.
 39 Broadway, 32nd floor,
 New York, N.Y. 10006
 (212) 422-7130

CIRCLE 310 ON READER CARD

VSAM LOAD DLI/IMS VSAM UPDATE
 INTERNAL SORT — QUIKSORT

C C Report Writer • Database Utility
 F F Intelligent Utility • Mini-language
 O O Increase Programmer Productivity
 II 62 Reduce Turnaround Time

quikjob

IBM 360/370 UNIVAC VS9
THE PERFORMANCE EXPANDER
 In use by over 400 companies. Four years on "Datapro Honor Roll."

ICP Million Dollar Software Club.
 Call Mac or Bob, (513) 435-9514, send your card with this ad, or write for more details.

VSAM RANDOM VSAM SEQNTL
 ISAM OTHER DATA BASES DBOMP
SYSTEM SUPPORT SOFTWARE, INC.
 5230 Springboro Pike • Dayton, Ohio 45439

CIRCLE 311 ON READER CARD

"1978 MAINFRAME USER SURVEY" AVAILABLE NOW.

A new 300 page report providing the most comprehensive analysis of the mainframe systems market has just been published by DATAMATION magazine.

This in-depth survey is a major study of EDP user buying plans and attitudes for the next two years . . . all essential data for industry analysts, planning and marketing executives as well as computer users.

Available immediately the survey is priced at \$950., \$925. if payment is enclosed with the order. Additional reports are \$200 each. For complete information contact Deborah Dwelley (203) 661-5400.

DATAMATION. magazine

TECHNICAL PUBLISHING COMPANY
 A DUN & BRADSTREET COMPANY
 35 Mason St., Greenwich, Conn. 06830

CIRCLE 285 ON READER CARD

Line Transients can cause **BIG MISTEAKS!**
 Protect your computer data with HOLLAND'S PowerGuard Transient Voltage Alarm and Recorder.



- Detects and measures power line fluctuations
- Strip Chart Recorder verifies amplitude and duration of transients
- Automatic Alarm signals transient occurrence in AC power line
- Low cost protection of data integrity... only \$1485

HOLLAND ELECTRONIC'S unique PowerGuard has been selected by General Electric as one of the ten most wanted instruments in the industry. Call us today for a demo and save time and money on expensive records of computer data.

HOLLAND ELECTRONICS, INC.
 870 East 82 Street
 Brooklyn, New York • 11238
 212-649-7230

CIRCLE 293 ON READER CARD

Before you buy or sell used computer equipment consult

COMPUTER PRICE GUIDE

"The Blue Book of Used Computers"

Quarterly publication contains current price information about used IBM computers and peripherals. Includes newsletter about current price trends and availabilities.

\$5 per issue - \$18 annual subscription

Computer Merchants inc
 75 South Greeley Avenue, Chappaqua, New York 10514
 Member Computer Dealers Association (914) 238-9631

CIRCLE 276 ON READER CARD

POSITIONS AVAILABLE NATIONWIDE

CALL TOLL FREE 800-426-0342

PROGRAMMER/ANALYSTS To 25K
 Cobol, PL/1, BAL & Fortran.
 SYSTEMS PROGRAMMERS To 30K
 IBM OS, H6000 & CDC Internals.
 PROJECT LEADERS To 30K
 Degree + Mfg. experience.
 T.P. PROFESSIONALS To 28K
 Software development & network design.
 CAD/CAM PROGRAMMERS To 30K
 1 to 3 yrs. experience + degree.
 Give me a call to discuss these openings as well as several others.

Call
 Bill Isgrig or forward resume to:
PARKER PAGE ASSOCIATES
 P.O. Box 12308
 Seattle, Wash. 98111
 Offices in Washington, D.C., Chicago
 Atlanta & Portland, OR

CIRCLE 306 ON READER CARD

COMPU COVER

PAT. PENDING

PROTECT YOUR SYSTEM FROM FAULTY SPRINKLER AND OTHER WATER LINE HAZARDS!

360/370, SYS 3, SYS 32



S/3 SUPPLY COMPANY INC.
 P.O. BOX C
 RUTHERFORD, N.J. 07070

CIRCLE 312 ON READER CARD

COMPUTER ROOM FLOORING and AIR CONDITIONING

Sell us your used computer room flooring and air conditioning.

Buy our reconditioned flooring and air conditioning (ED-PAC, LIEBERT, etc.). Completely guaranteed.

D.V.I. CO., INC.
 P.O. Box 33
 Paoli, PA 19301
 (215) 647-4916

CIRCLE 290 ON READER CARD

PROGRAMMERS AND ANALYSTS

IF YOU ARE A PROGRAMMER, PROGRAMMER/ANALYST OR SYSTEMS ANALYST AND WOULD LIKE THE MOST INDIVIDUALIZED JOB SEARCH OFFERED IN THE DATA PROCESSING FIELD TODAY, EITHER ON A LOCAL OR NATIONAL LEVEL, SEND YOUR RESUME IN CONFIDENCE TO:

AFFIRMATIVE ACTION FOR PROFESSIONAL WOMEN, INC.
 P.O. BOX 1301
 SARASOTA, FLORIDA 33578
 "WE AGGRESSIVELY SUPPORT AFFIRMATIVE ACTION"

CIRCLE 265 ON READER CARD

TSO for VS1

IS HIGH PERFORMANCE LOW OVERHEAD

CHECK THESE FEATURES

- Edit with full screen capability
- Interactive program execution
- Internal reader job submit
- Operations console support
- Output retrieval with RES support
- Dataset maintenance
- System maintenance
- Standard IBM TSO commands
- Program development
- Enhanced 3270 usability
- Data entry
- Full ASCII terminal support
- System debugging
- No user swapping
- Text editing
- No TCAM
- Performance monitoring support
- No VS/2 overhead
- User command interface

TSO
 Write for Details
 1410 N. GARDNER
 ANAHEIM, CA 92805
 (714) 991-9300

CIRCLE 314 ON READER CARD

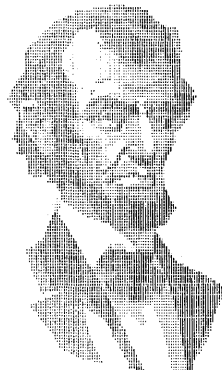

COMPUTER PICTURES

\$7.75 will bring you a complete set of 23 computer pictures (4 Snoopys, 5 Christmas, 6 naked ladies, Star Trek, Abe Lincoln and more) on 58 sheets of 14 7/8 X 11 paper. Data Analysis Systems, P.O. Box 162, Franktown, CO 80116.

CIRCLE 280 ON READER CARD

BROWN & ROOT, INC.

Brown & Root, the nation's largest engineering and construction firm has immediate openings in Houston for programmers, programmer/analysts and systems analysts with 3 or more years' experience. The Computer Services Department is expanding to support a large scale information systems development effort including:

INVENTORY ESTIMATING SCHEDULING PERSONNEL COST ACCOUNTING MATERIEL AND OTHER APPLICATIONS

These systems are to be designed, developed and implemented over the next several years in support of our worldwide construction and engineering opportunities. Data Processing professionals with experience in any or all of the following areas are desired.

IMS Application Design Project leadership and management
IMS Application Programming CPM/PERT processors
On-line application design and programming

For the programming positions COBOL and IBM 370 experience is preferred. These positions represent career opportunities in a rapidly growing company.

These positions provide excellent income commensurate with your experience, a generous benefit package, excellent location and outstanding opportunities for both professional achievement and personal growth within our organization.

Call or send resume in complete confidence to:
 Ms. P. K. Wright—Post Office Box 3
 Houston, Texas 77001—(713) 676-8720

BROWN & ROOT, INC.
 And Associated Companies/
 Serving Progress the World Over
A HALLIBURTON Company
 We Are an Equal Opportunity Employer M/F

CIRCLE 273 ON READER CARD

GET INVOLVED WITH THE TOP DATA PROCESSING JOB MARKET IN THE COUNTRY!

If you live in Chicago or desire to relocate to the Chicago area, then take advantage of an applicant oriented job market.

See how helpful a good search firm, which has access to a variety of openings, can be to you.

Our goal is to become the most reputable and dependable Data Processing Search Firm in the business. If interested, send resume or call:

(312) 858-8540

Mr. Annes

Monday thru Friday 9AM to 5PM

CATALYST SEARCH LTD.

646 Roosevelt Road
Glen Ellyn, IL 60137

equal opportunity employer m/f

CIRCLE 274 ON READER CARD

PROGRAMMERS AND ANALYSTS

If you are a programmer, programmer/analyst or systems analyst and would like the most individualized job search offered in the data processing field today, either on a local or national level, send your resume in confidence to:

E.D.P. SEARCH, INC.

P.O. BOX 331
HARTFORD, CONN. 06101

CIRCLE 291 ON READER CARD

SYSGEN

We are currently seeking the following for over 80 positions nationally.

NCP-3705\$27M
VTAM-TSO-Gen's\$30M
MVS-Internals\$26M
OS-MVT Gen's\$26M
CP & Evaluation.....\$27M

EDP AUDITOR'S

Over 300 EDP Audit positions.

Audit Mgr\$42M
SR. EDP Audit.....\$29M
etc. etc. etc. etc.

We are the recognized national leaders in these fields.

Contact Skip Wall 405-525-8833

EDP Search P.O. Box 12566

Okl. City, Ok. 73157

CIRCLE 292 ON READER CARD



WORK IN SUNBELT Applications Programmer

3 to 5 years in-depth experience in real-time assembly language minicomputer applications programming with working knowledge of operating systems.

Job Responsibility

Development, implementation, and maintenance of software for monitoring control of pipeline supervisory control systems located in Houston, Texas. Salary and benefits competitive and commensurate with experience.

Send Resume to:

Harry Miller
Continental Pipe Line Company
5 Greenway Plaza East
Suite 2030
Houston, Texas 77046
Equal Opportunity Employer
PRINCIPALS ONLY—NO AGENTS

CIRCLE 277 ON READER CARD

K **Knauth & associates, inc.**
2949 N. MAYFAIR RD.
MILWAUKEE, WI 53222

SOFTWARE ENGINEERS 25-31K
DATA BASE SPECIALIST 25-27K
CORPORATE PLANNERS 25-35K
TECHNICAL SUPPORT 25-30K
SOFTWARE SPECIALISTS 20-30K
MIS SYSTEMS ANALYSTS 20-27K
MINI SPECIALISTS 17-24K
PROGRAMMER ANALYSTS 15-22K
PROJ. EE FOXBORO EXP. 15-22K
BUSINESS PROGRAMMERS 15-20K
MFG. PROGRAMMERS

Contact:
E. M. MONET
your **FUTURE**
is our concern **TODAY!**

Confidential Search—Nationwide
(414) 259-9540

CIRCLE 298 ON READER CARD

EDP SPECIALISTS

outstanding opportunities

SYSTEMS ANALYSTS / PROGRAMMERS, \$15,000-\$40,000. Immediate Pennsylvania and national openings at all levels, light experience through management. Reply in strict confidence to WEIR PERSONNEL SERVICES (emp agcy), 535 Court St., Reading, PA 19603 (215/376-8486).

SR. PROGRAMMER ANALYSTS, \$18-26K. 2+ yrs IBM ALC, COBOL, CICS helpful. Manufacturing & banking pros needed just minutes from great camping, fishing, hunting, IBA PERSONNELL, 901 McKay Tower, Grand Rapids, MI 49503 (616/456-1721).

all positions listed are fee-paid



CIRCLE 302 ON READER CARD

UNIVAC SYSTEMS PROGRAMMERS

ISD is looking for a Senior Systems Programmer to support Libraries & Processors on UNIVAC 1100 Series Systems.

Experience in Systems Support for any of the following packages:

- DMS 1100
- ASCII COBOL
- ASCII FORTRAN

ISD is a Computer Utility in the San Francisco Bay Area offering Batch & Demand remote processing nationwide.

Please Respond To:

Information Systems Design, Inc.
3205 Coronado Drive
Santa Clara, Calif. 95051
(408) 249-8100
Equal Opportunity Employer

CIRCLE 294 ON READER CARD



CONNECTICUT WANTS COMPUTER PROGRAMMERS

Experienced Programmers and Analysts are in growing demand, both in applications and systems software. Whether you have experience in large systems or small; one year's experience or ten; COBOL or RPG II, or BAL, or FORTRAN or whatever; whether you've worked in manufacturing, consulting, banking or insurance, there is a good chance ROMAC can help you. We specialize in data processing, finding the right job for you. Salaries are commensurate with experience. Call or write



One Financial Plaza
Hartford, CT 06103

Telephone: (203) 525-8037

Confidential - All Fees Company Paid
Serving New England and the Eastern Seaboard

CIRCLE 308 ON READER CARD

**PROGRAMMERS
ENGINEERS**

with systems programming/software dev exp IBM OS systems or minicomputer assembly language sought by quality energy, mfg, systems & consulting cos. Software, hardware & real time applications optys. \$18-29,000 SW, SE, W & NE.

Other clients seek business applications analysts & programmers with financial, mfg, or energy co applications exp Cobol, PL1, RPG, assembly \$18-27,000 SW & SE.

Confidential contacts controlled by you. Resume to J. L. Gresham, BChE, MBA will contact you at home first. Est. 1966, members AIChE. Fees paid. (713) 622-1370.

Systemation Consultants, Inc.
employment service
1410 Post Oak Tower Houston, Texas 77056

CIRCLE 313 ON READER CARD

**MOUNTAIN BELL
IS HIRING
PROGRAMMERS
AND
SYSTEMS PROGRAMMERS**

IBM 370/MVS or OS
ALC, COBOL, PL/I
CICS, VSAM, JES III, MVS, IMS
HONEYWELL 6000
COBOL, GMAP, IDS

Screening tests administered

Experience required:

Programmers—1 year
Systems Programmers—2 years

Jobs located in Denver, Colorado

Starting salary: 14-19K Commensurate with ability

State on resume your hardware and software experience.

Mail resume to:

**MOUNTAIN BELL
Room 5-40
1750 Arapahoe
Denver, Colorado 80202**

Mountain Bell is an equal opportunity employer

CIRCLE 301 ON READER CARD

**DATA PROCESSING
EXECUTIVES**

IF YOUR PRESENT SALARY EXCEEDS \$20,000 PER YEAR AND YOU HAVE 5 OR MORE YEARS OF EXPERIENCE IN MANUFACTURING AND SERVICES, BANKING, DIVERSIFIED FINANCE, INSURANCE, TRANSPORTATION, RETAIL, OR UTILITIES AND WOULD LIKE TO HAVE YOUR CAREER HANDLED BY PROFESSIONALS, SEND YOUR RESUME WITH PRESENT SALARY TO:
(CLIENT COMPANIES PAY ALL FEES)

**PERSONNEL RESEARCH, INC.
P.O. BOX 175
SARASOTA, FLORIDA 33578**

CIRCLE 305 ON READER CARD

Engineers

**Software
Systems
Developers**

**EDP Terminals for
Retail Institutions**

We are now designing new advances in EDP terminals with greater computing and communications power . . . to maintain NCR's leadership position in total retail systems. To accomplish our objectives, we're enlisting the best talent in the field.

Several openings exist for both senior level analysts and entry level programmers for software systems design and assembly level programming of micro-computer (8080) based systems. Experience should include I/O driver design, language processor design, and/or real-time operating system design.

Senior Level Analysts

Requires BSEE or Computer Science degree plus 4-8 years of recently related work experience.

Programmer Analyst

To develop and enhance operating systems software and support for Retail Operating Systems department. You will define projects under broad guidelines and objectives and specify programs for the system application; develop and participate in appropriate tests to assure systems reliability.

A degree and 2 years experience with micro/mini processor and real time programming as well as a good working knowledge of recent developments in hardware/software application will qualify you for consideration. This is a highly visible position.

Entry Level Programmers

Requires 1-2 years work related experience.

Interested candidates are invited to send resume or call collect: Mr. Robert W. Donovan, Personnel Resources, NCR Corporation, Engineering & Manufacturing, Cambridge, P.O. Box 728, Cambridge, Ohio 43725. (614) 439-0291



Complete Computer Systems

An equal opportunity employer.

SOURCE DATA

BOOKS

STANDARDIZED DEVELOPMENT OF COMPUTER SOFTWARE

by Robert C. Tausworthe

This book lies somewhere between a gem and a pain. A gem because of its breadth in covering what to expect on a software development project from the structured programming viewpoint—but a constant frustration because it is liberally sprinkled with references to actual standards in chapters and appendices not yet published.

The volume has an interesting history: It was first produced at Jet Propulsion Laboratory as an actual standard to be used on a large missile project. (I did see a few chapters at the time that were circulating about the "old boy" circuit in the aerospace industry and was interested because SDC was doing something of the same thing at the time.) It was later given an official government printing (putting it in the public domain). Prentice-Hall got hold of a copy and, impressed, arranged for its publication, complete with dangling references to unavailable material. Actually, the author says that JPL plans to publish appendices this summer; hopefully, Prentice-Hall will pick that up, too, and we will have a complete work.

Substantively *Standardized Development* covers just about every aspect of software development, showing how top-down structured programming impacts each development phase. The early theoretical development covers such salient features as the developmental cycle, program structure and conceptual hierarchies, and principles of program documentation. Performance or functional analysis and specification, the first developmental phase, is covered in a general fashion. No particular point is made of any particular approach to analysis, top-down or otherwise, but the feeling is there. We are warned to look for real needs and to differentiate between functional requirements and program definition, but there is little emphasis on trade-offs or other analytic devices except information flow diagrams. The standard here is a specification standard rather than an analytic standard.

The program design section does

get into the top-down rules, modularization principles, and alternative design considerations. Treatment of these rules is not deep, and design rules are placed in the context of the whole process rather than being the whole of design as some advocates seem to believe. Again, specification is an indigenous part of design; a fair amount of space is devoted to presentation techniques, module classification, and criteria for establishing levels of abstraction.

Chapters are devoted to both real-time and non-real-time programs. Standard control structures and Mills' mathematical proof of program correctness of "proper programs" dominate non-real-time. Multiprogram considerations, resource trade-offs, and similar strictures receive attention for real-time programs. Quite a bit of space is devoted to techniques for rendering non-proper programs proper, and several of the issues of structured programming—abnormal terminations, concurrency handling, and program efficiency—are also examined.

At this point, two tools—structured programming languages and decision tables—are covered. A language is proposed which is built upon existing language structures and hence is missing some of the more esoteric features of a proper structured programming language. It's tied to existing data structures, for instance. In short, a practical preprocessor to be used on a software project, as it undoubtedly was.

Tausworthe strongly supports the notion of concurrent design, code, and test offered by structured programming and points out various approaches to these. However, his chapter on verification and validation (reviews, audits, and tests) is rather weak. He develops some expressions of confidence limits for verification and looks at proofs of correctness techniques, but does little toward developing a full-fledged testing program or even a quality assurance program. Test documentation is covered, but not as wholeheartedly as specifications are.

The last chapter deals with management. Tausworthe's ideas for programmer teams for large projects, programming support libraries, and project

administration are expounded, all good structured programming approaches. However, as an old hand at software systems management, I'd say his standards for configuration management and change control are inadequate. He doesn't show how to take full advantage of programming support libraries for management purposes. Still, software management is a broad subject and cannot be covered in the depth one might like and kept in balance with the rest of the book. Some insights are offered, if not the whole ball of wax.

In general, this book offers one of the best overviews to come along of structured programming principles applied to the whole software development process. While other books may develop specific techniques in greater depth, this is usually at the expense of other notions. This book has a fairly balanced presentation, not deep, but certainly good guidance. If the "standards" volume is published to augment this "methods" volume, *Standardized Development* could well be a standard reference on a lot of shelves. Prentice-Hall, N.Y. (1977, 379 pp., \$19.95).

—N.E. Willmorth

STANDARDS AND PROCEDURES FOR THE DATA BASE ADMINISTRATION FUNCTIONS

by Robert M. Curtice

This handbook is a checklist of standards and procedures that should be developed and implemented by any shop using DBMS or data dictionary software. The checklist is presented in such a manner that it is independent of hardware and software specifics. Actual standards, of course, are dependent on the specifics of a hardware/software configuration, so standards are presented in the following manner: "Online transaction processing modules should not exceed X bytes in storage requirements."

The handbook is organized in great detail. Three principal sections are presented: Data Base Design and Development, Data Base Programming, and Data Administration. Most of the key standards that one is likely to consider are

covered in this book. For example, under Data Base Programming, program limits, selection criteria, sorting, statistics, etc., are covered. The author does not hesitate to make specific recommendations when his experience has resulted in a conclusion which is generally applicable. For example, "Use of sorted chains. When relationships are to be maintained by the DBMS in a specified order, update becomes more expensive. Sorted chains should not be specified unless the guidelines are met."

An extensive list of references is provided in an unusual and useful fashion: They are listed at the immediate conclusion of each section where their use may be warranted.

This book could be very important to DBMS implementers. If there is any most commonplace failure in the data base world, it is the implementation of systems which are not data independent and in which, because no management control has been exercised, a DBMS is simply used as another access method. Following the guidelines in this handbook will go a great length toward preventing that from happening to you.

The book is not a text nor could it be easily converted to such. It is not an expository writeup. It is a good, practical, detailed list of standards that should be implemented by users of DBMS software and, therefore, is strongly recommended for such organizations. Arthur D. Little, Inc., Cambridge, Mass. (1978, 71 pp., \$25).

—George Schussel

THE RISE OF SYSTEMS THEORY: AN IDEOLOGICAL ANALYSIS
by Robert Lilienfeld

The premise of this book is that a number of disciplines have emerged in the 20th century that can be classified under the general heading of "systems thinking" and that these originally separate disciplines have converged in philosophy, goals, principles of exposition, and results. On the whole, the author is unhappy with these developments, and the purpose of the book is to argue the case against systems theory.

Part I is an overview of those disciplines that use systems techniques. These include cybernetics, information theory, statistical communications theory, artificial intelligence, operations research, game theory, systems analysis, and large-scale simulation. While sparse and incomplete, this overview does serve to acquaint the reader with the main thrusts of the various disciplines and to see the common threads, in terms of both technique and philosophy, that tie them together. This part serves to demonstrate that the systems disciplines represent what is basically one unified approach and way of

thinking; differences are not intrinsic but are based on the specific features of narrow problems. Unifying principles include: viewing objects of study as systems of interrelated variables with an "outside" and an "inside," a hierarchical approach to problem statement and solution, the use of models, and the quantification of aspects of interest and the use of sophisticated mathematical techniques on the quantized variables.

Having established the subject to be discussed, the author attacks system theory on two levels. First, he asserts that the societal claims of systems advocates have not been met. He cites a number of examples of government-funded contracts that have come to nothing or done actual harm. The well-documented criticisms of *The Limits to Growth* are also cited. He concludes by asserting that no substantive theoretical or even "applied"



sociological, political, or economic problems has been resolved by the elaboration of systems theory.

The second level of criticism has to do with the implications of systems philosophy with respect to how our society is organized. He fears that systems philosophy promotes bureaucracy, meritocracy, and authoritarianism. Individual responsibility and freedom is gradually handed over to increasingly unified and centralized social institutions that are justified by and dependent upon the systems experts.

Because it forces the reader to think of the larger implications and utility of a particular corner of modern science and technology, this is a useful and challenging book. John Wiley & Sons, N.Y. (1978, 292 pp., \$19.95).

—Dr. William Stallings

THE PROGRAMMER'S ANSI COBOL REFERENCE MANUAL
by Donald A. Sordillo

This unusual book is destined to be an invaluable reference tool for many—not only for working programmers, but for those involved in planning and sales activities dealing with COBOL applications.

The book is organized alphabetically, with a chapter for each letter except X and Y, and consequently there is neither a table of contents nor an index. The reader can look up any reserved word or concept (such as "logical operations") and find not only the official definitions of the desired subject, but well written examples, with many useful diagrams and tables. And perhaps the most useful aspect of Sordillo's approach to the material is his inclusion of excellent cross-references to related concepts so that, unlike the official ANS X3.23-1974 COBOL standard publication, the reader can attain a meaningful understanding of the implications and interrelationships of every element of the language without drowning in a sea of wordy legalisms.

An important dimension to the book is its emphasis on differences between the predecessor (1968) standard and the current one—making this book useful to anyone involved in conversion of older COBOL programs. (A summary of "68 COBOL" appears in Chapter S.) And there is much to recommend the book to those responsible for management of software houses or to computer manufacturers that implement COBOL compilers and may need to upgrade rusty COBOL familiarity. There is even a 20-page section on structured programming, and a single appendix giving the general formats of all language constructs.

In any effort to make sense of so much material, errors can creep into the final product in spite of the most diligent human efforts; the list below is sufficiently small to not represent a serious detraction from the book's quality:

Page 214: "Level 49 cannot be a qualifier" is incorrect since it can serve as a qualifier of a condition-name (level 88 entry).

Page 273: The list of prohibited characters in the CURRENCY SIGN entry is incomplete.

Page 273: It is asserted that ELSE is no longer permitted in IF; the correct wording is that OTHERWISE is no longer permitted.

One addition might be useful in a future edition of this reference book: an appendix concerned with the federal COBOL standard, delineating the four subsets (low, low intermediate, high intermediate, and high) defined in FIPS Publication 21-1. Prentice-Hall, N.Y. (1978, 378 pp., \$22.50).

—Ken Seidel

Are you running CICS or is it running you?

The problem has been to get performance reporting, management information and reports your users can understand all in one place.

That's why you'll find yourself using CONTROL/CICS so much.

CONTROL/CICS is the only product that provides all the data you need to make critical decisions, maintain good user relations and improve your response time. And the information will be in a format that is useful and meaningful to everyone in your company.

CONTROL/CICS provides performance reporting and:

- Accounts
- Customer information
- Cost accounting
- Sales and inventory
- Statistical analysis
- Workload analysis
- Billing and time charges
- Pricing and discounts
- Inventory management
- Order processing and shipping
- Production control and scheduling

If you need to optimize on-line system performance, analyze trends and forecast

future hardware needs; find out more about CONTROL/CICS.

It's the one product that will help you run your CICS system.

For more information, call or write us today.



**Boole &
Babbage**



SMS Division
510 Oakmead Parkway
Sunnyvale, Ca. 94086

In California: (408) 735-9550

Outside California dial toll free: (800) 538-1872

Helping you get the most from your system.

Gentlemen:
Please send me information on CONTROL/CICS.

name _____

title _____

company _____

address _____

city _____ state _____ zip _____

phone _____

system _____

REPORTS AND REFERENCES

DISTRIBUTED PROCESSING MANAGEMENT

Booz, Allen and Hamilton, using their consulting experience and the help of a user panel, have surveyed what they consider four of the hottest "hot buttons" facing management today: the technology of distributed processing, human resource problems associated with distributed processing, IBM copies (plug-compatible processors), and inter-organizational networks. The findings, based on a business group meeting of the consultants and panelists, are presented in a 53-page booklet "EDP Hot Buttons," Vol. V, No. 3 of the FAIM Technology Reports series. \$25. FAIM TECHNICAL PRODUCTS, INC., P.O. Box 1013, Melville, NY 11746.

ELECTRONIC MAIL

Electronic Message Systems: The Technological, Market and Regulatory Prospects is a 328-page study prepared for the Federal Communications Commission by Kalba Bowen Associates and the MIT Center for Policy Alternatives. It begins by defining a new acronym for us, EMS—for Electronic Message Systems—which covers terminal to terminal messages which otherwise would have been sent by phone or relegated to the depths of the Postal Service.

Product information is provided (this part comes from interviews with 50 manufacturers), along with a review of the literature (in both bibliographic and abstract form), and analysis prepared by the study team. \$30, prepaid, to KALBA BOWEN ASSOCIATES, INC., 12 Arrow St., Cambridge, MA 02138.

SERIES/1 PRODUCTS

A report from SBS Publishing looks at non-IBM suppliers of Series/1 products, including profiles of vendors (nearly 40 are covered by the analysis), a section on various ways the Series/1 can be used to off-load mainframes, and a discussion of maintenance alternatives. The 250-page report predicts a \$3.5 billion market for Series/1 products by 1982—\$2 billion of software and \$1.5 billion for add-on peripherals.

Non-IBM Suppliers of Series/1 Products, priced at \$350, is available from SBS Publishing, 4320 Stevens Creek Blvd., Suite 190, San Jose, CA 95129 (408) 243-8121.

TWO NEW IN-DEPTH IRD REPORTS

The market for nonimpact printers will double to over \$1 billion by 1988, while the cost of lasers will be reduced to below \$20 each in the same timeframe.

These are the conclusions of International Resource Development, Inc., a market research and management consulting firm that publishes comprehensive studies of equipment markets and technology.

The latest two studies, *Non-Impact Printers* and *Lasers in Reprographics and Communications* provide a good summary introduction to the respective industries. Each report includes an overview discussion of the technology, detailed description of available equipment and the manufacturers, and analysis of the current and future markets. Each study is based in part on interviews with some of the firms themselves; *Non-Impact Printers* includes the results of a 40-firm survey in which the companies reveal their attitudes and plans to purchase. For *Lasers . . .*, over 100 suppliers and users were interviewed. Each report is approximately 200 pp. *Lasers . . .* sells for \$895. *Non-Impact Printers* is \$795. INTERNATIONAL RESOURCE DEVELOPMENT INC., 125 Elm St., New Canaan, CT 06840.

THE OFFICE OF THE FUTURE

What is an automated office, anyhow? It means more than just buying a word processor and throwing out your old manual typewriters, according to the introduction of *Automated Office Solutions*. The new Datapro report sees it as the "gathering point for certain technologies, techniques, and functions normally scattered far and wide in non-automated offices."

These technologies, techniques, and functions are defined and divided into five sections in the two-volume monthly updated reference set as Input, Process, Storage, Output, and Distribution. Each section discusses solutions with regard to available technology with emphasis on personnel and management considerations.

Unlike the technology reports for which Datapro is so well known, which report on individual pieces of equipment and software, this series is a management guide with reports such as "How to Get a Good Consultant" and "How to Conduct a Word Processing Feasibility Study." Although the price tag of \$230 is a little steep for someone with a casual interest, the manager with ongoing office management responsibility would find the service a handy reference. DATAPRO RESEARCH CORP., 1085 Underwood Blvd., Delran, NJ 08075.

ACS IMPACT

The Yankee Group's recent study on the Bell Data Network focuses on its impact on the user, the dp industry, and the communications industry. The anal-

SYSTEMS PROGRAMMING PROFESSIONALS

Control Data Corporation has career growth opportunities, in pre-sale, post-sale and consulting, located throughout the United States. Applicants should have experience in maintaining, modifying or extending any one of the following operating systems.

■ CYBER 17X or 6000 with NOS, NOS/BE, SCOPE or KRONOS

(Opportunities in Austin; Albuquerque; Boston; Chicago; Detroit; Fredericksburg; Livermore, California; Monterey, California; Miami; New Jersey; Philadelphia; Ponca City, Oklahoma; St. Louis; San Francisco Bay Area and Washington, DC)

■ System 370 or 360 with DOS, VS, VSI, SVS or MVS

(Opportunities in Albuquerque, Atlanta, Boston, Denver, Detroit, Mil-

■ CYBER 18 with 1700 MSOS, RCOS or ITOS

(Opportunities in Dallas, Los Angeles and Minneapolis) or have extensive assembly language on any of the above computers.

For immediate consideration, please send resume, salary history and geographical preference to:

John N. Powers

GD CONTROL DATA CORPORATION

60 Hickory Drive, Waltham, Mass. 02154
OR CALL COLLECT: (617) 890-4600, ext. 245
An Affirmative Action Employer M/F

waukee, Minneapolis, New York, Philadelphia, Pittsburgh, and Washington, DC)

■ AN/UJK-7 OR AN/UJK-20

(Opportunities in New England, New Jersey Shore, Norfolk/Newport News, Virginia, San Diego, California and Washington, D.C.)

■ Intel 8080 or other Microprocessors (These positions in the Houston and Philadelphia areas)



CIRCLE 204 ON READER CARD

ysis includes exploration of AT&T's motivations, acceptance by various kinds of users, and future markets. The report will be updated four times during the year. \$690. THE YANKEE GROUP, Harvard Square, P.O. Box 43, Cambridge, MA 02138 (617) 868-6139.

DOWN-TO-EARTH SATELLITE RESULTS

Satellite Business System's report on Project Prelude is now available, at no charge. The project provided the first linkup of business equipment with high-speed satellite communications capability on an end user's premises. Some objectives of the experiment were: to determine user requirements, assess new applications, and bring together state-of-the-art equipment for evaluation and testing in a realistic business environment. The SBS report uses results from questionnaires filled out by over 1,000 people present at the 52 Project Prelude sessions.

According to the study, teleconferencing is an acceptable, and even in some cases preferable, alternative to regular conferences. The main reason cited for this was time saved in travel and decision making, with cost saving found to be a secondary factor.

40% of the responders, who had previously had little or no familiarity with facsimile communications, said they would use it five times a week or more if it were available. Asked "If you had a terminal and information storage and retrieval capacity would you want to personally operate the terminal?" approximately one fourth of the responders said yes.

A copy of the *Project Prelude Evaluation Report* is available from SBS PUBLIC AFFAIRS DEPT., 8003 Westpark Drive, McLean, VA 22102 (703) 827-2057.

LSI

The increasing tendency of semiconductor manufacturers to obtain large portions of their technological services from outside vendors has resulted in there being so many of these vendors and in such diversity that it is possible to subcontract all the steps in designing and building an LSI device.

A 185-page report from Anderson/Bogert, a high-technology consulting firm, entitled *Vertical Dis-Integration*, outlines factors to consider when thinking "do or buy" and provides information on potential vendors and methods of working with them.

The report, at \$475, is being distributed by ELECTRONICS TREND PUBLICATIONS, 10050 N. Wolfe Rd., S.W. #3, Suite 200, Cupertino, CA 95050.

Software/Hardware Professionals

For the stimulation and career growth inherent in developing a whole new generation of large-scale computer systems...

**The big move is to
NCR/San Diego.**

We're involved in one of the biggest, most far-reaching pioneering efforts ever undertaken by a major computer manufacturer. Our award-winning facility in Rancho Bernardo is the launching site of two development thrusts that will shape the future of NCR. One is on-going development of a large-scale virtual memory system made possible by a new breed of NCR-produced microprocessor firmware. The other is a new interactive system that will break new ground in transaction processing and distributed processing networking.

Latest NCR mainframes and software

You'll be working with our most powerful Criterion mainframes, latest advances in data communications, VLSI circuitry, the newest techniques in emulation, non-disruptive upward migration, and systems architecture. You'll be using new PASCAL-based languages; and all of NCR's far-flung engineering resources will be available to you.

Visibility at all job levels

There are no quiet backwaters in our San Diego operation. As part of one of NCR's highest priority, long-range decision-making enterprises, every software/hardware professional functions in a creative climate that not only permits but requires innovative thinking. You'll be a key member of a small team with broad responsibilities and high visibility.

California living at its best

Our pioneering development groups are concentrated in Rancho Bernardo, 22 miles up the coast from San Diego. Our 114-acre location here has been called "one of the 10 best-designed industrial facilities in the nation". You'll be near one of California's most attractive cities, and 70 miles of beaches stretching from San Juan Capistrano to the Mexican border. You'll have a working and living environment that's the envy of the EDP industry.

Immediate, across-the-board openings

If you have an appropriate engineering or computer science degree (or equivalent), and a year or more of experience in one or more of the areas listed below, contact us at once. For a high level review of your qualifications and a promptly arranged interview, send detailed resume and salary history to: **Mr. George Rice, Manager, Professional Placement, Engineering and Manufacturing, Dept. J-65, NCR Corporation, 16550 W. Bernardo Drive, San Diego, CA 92127.**

Vacationing near us this summer? A brief visit to NCR can be an eye opener. So if you're going to be in our area, plan to stop by. Contact us in advance for a technical interview.



Immediate Openings— Software areas:

- Distributed Network Architecture
- Transaction Processing
- Interactive Processing
- Data Base Design
- Performance Measurement & Analysis
- Configuration Management
- File Access Methods
- Operating System Development
- Compiler Design/Development
- Firmware Development
- Diagnostic Programming
- Test Systems Development
- Software Quality Assurance
- MICR Proof Of Deposit Software
- Systems Architecture

Immediate Openings— Hardware areas:

- Design Automation Engineering
- MICR/OCR/OMR Engineering
- Memory Device Engineering
- Logic Design Engineering
- Components Engineering
- Systems Architecture
- Test Systems Development
- I/O Subsystem Configuration
- Systems Integration Test
- Product Engineering—
Mechanical, Optical, Electrical
- Systems Safety Engineering

NCR

Complete Computer Systems

An equal opportunity employer

Your ideal career and your ideal hometown. You can have both at TI.

Your kind of work. Your kind of town.

You don't have to give up one to get the other at Texas Instruments.

TI has dozens of hometowns.

You like bright lights, blue skies and sports champs? We give you Dallas. Houston. Austin. Or Lubbock, Texas.

You crave New England autumns? We can make you happy in Attleboro, Mass.

You want a dramatic change? How about Singapore. Madrid. Nice. Buenos Aires. Or Tokyo.

You can wind up almost anywhere when you get with TI.

Career-shopping at TI is a trip itself. Through technology.

You have more than 20 major product fields to pick from. And we're leaders in many of them.

For example, TI recently:

- Strengthened its competitive position in the MOS memory market with the 16K-bit dynamic

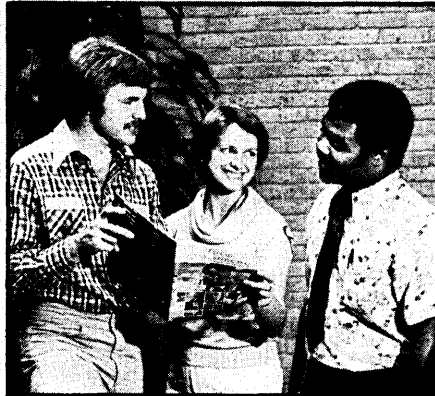

RAM, 4K-bit static RAM and the 16K-bit EPROM

- Expanded its microprocessor family with new peripherals and minicomputer subsystems
- Accelerated development of high-performance structures and processes required to continue the company's leadership in semiconductor components
- Introduced the first commercial equipment using magnetic bubble technology
- Achieved high-volume production of the most sophisticated handheld calculator on the market
- Continued development of three-

dimensional seismic data gathering and processing, an exclusive approach to petroleum exploration

- Developed a microprocessor-controlled Loran C receiver for navigation and a VHF/FM transceiver for marine communications

Today, you can have the kind of career you want without compromising your lifestyle.

People join TI for love of technology. They stay for a lot of reasons.



Send for the 34-page picture story of TI people, places, and opportunities. And send us your resume in confidence to

George Berryman,
P. O. Box 225474,
Dept. CC1, MS 67,
Dallas, TX 75265.

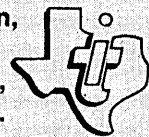

TEXAS INSTRUMENTS

INCORPORATED

An Equal Opportunity Employer M/F



CIRCLE 219 ON READER CARD

VENDOR LITERATURE

MODEMS

The Special Offer Division of this well-known modem-maker has published a 24-page catalog of factory tested and warranted used equipment available for purchase or lease at reduced rates. In addition to describing modems (from 2400bps to 9600bps), the catalog lists accessories, such as test sets, solid state buffers, and registered connecting devices. The original price is given with each unit's reduced price for the purpose of comparison. Maintenance terms are explained and a maintenance agreement is included, along with a lease agreement and a sales order form. RACAL-MILGO INFORMATION SYSTEMS, INC., Miami, Fla.

FOR COPY CIRCLE 365 ON READER CARD

IMAGE ANALYSIS

The Magiscan Image Analysis System is the topic of an eight-page, illustrated brochure. Photographs, schematics, and text detail applications of the system. A section entitled "how it works" uses a schematic and text to describe the steps from image acquisition to image output; the discussion covers digitizing the image, processing, amendment, and measurement. One page is devoted to the introduction of the three user programming languages, then each lan-

Magiscan Image Analysis Systems



guage is given its own page for a more detailed treatment. JOYCE-LOEBL, Woburn, Mass.

FOR COPY CIRCLE 377 ON READER CARD

BUSINESS SYSTEMS

A 12-page, illustrated brochure describes this vendor's model 700 and 800 business systems. A single page overview covers the company, its software, hardware, and services. Two pages are devoted to a discussion of the business environments these systems fit into. In a

more detailed, three-page discussion the vendor examines its software offerings, including its transaction controller, screen formatting, data input validation, telecommunications control, operating system, file system, and utility packages. Hardware also gets a three-page treatment, with descriptions of both systems in their smallest and largest configurations. Processors, crt's, disks, and other peripherals are described. The booklet concludes with the details on service offerings, and a final statement on the company. INTERDATA DIV., Perkin-Elmer Corp., Oceanport, N.J.

FOR COPY CIRCLE 366 ON READER CARD

CALCULATORS

An eight-page, four-color brochure describes the three scientific members of this vendor's recently announced E-Series of pocket calculators. After a one-page overview of the three units, each is treated in detail on its own two-page spread. Each is pictured, and text describes its functions. The manuals and accessories supplied with each calculator also are listed. Physical specifications and the limited warranty common to all three are described on the closing page. HEWLETT-PACKARD CO., Palo Alto, Calif.

FOR COPY CIRCLE 371 ON READER CARD

IRAN

The Oil Service Company of Iran (OSCO) has been established by a Consortium of major international oil companies and operates in South Iran on behalf of the National Iranian Oil Company. Already one of the largest oil and gas producers in the world, it is substantially expanding its capacity.

Challenging opportunities are available in the OSCO Information and Computer organization for:

TECHNICAL AND COMMERCIAL SYSTEMS ANALYSTS/PROGRAMMERS

at several levels of seniority, including project leaders.

Candidates should have a university degree in Computer Science or equivalent and, at the junior level, a minimum of four years experience in active programming and systems analysis.

- Excellent Benefits
- Family Status
- American Type School, K-12
- Tax Protection
- Annual Vacation

If interested, please send resumé to:

OVERSEAS RECRUITMENT DEPARTMENT
ASIATIC PETROLEUM CORPORATION
One Rockefeller Plaza, New York, New York 10020

Asiatic Petroleum Corporation, a wholly owned Company of the Royal Dutch/Shell Group, provides recruitment services under contract to OSCO, Iran.

CIRCLE 202 ON READER CARD

EDP SPECIALISTS

career search opportunities \$18-\$50,000

DIRECTOR SYSTEMS DEVELOPMENT to \$35,000. Midwest office of Big "8" accounting firm seeks director to supervise D.P. projects from proposal thru conclusion. Project leader & mini-computer exp req'd. Refer AT.

MIS DIRECTOR to \$35,000. Int'l. natural resources client seeks degreed self starter w/5-10 yrs exp in financial & mg systems. Will assume corporate-wide mgmt. resp. & have staff reporting. Southeast location. Refer RM.

MGR. DATA BASE-PHOENIX to \$32,000. "Fortune 500" firm seeks indiv. to direct file access methods for multi-development units. Req's degree, 5-10 yrs hvy tech bkgr, effective communicator. Excellent growth potential in a low cost-of-living area. Refer RS.

EDP AUDITORS to \$26,500. "Fortune 500" firm, due to continued growth, currently has opportunity available for sev. EDP auditors w/2+ yrs exp. Past system/programming bkgrd preferred. Full career benefits. Refer JS.

SYSTEMS ANALYSTS, \$19,000-\$25,000. DC/VA area. Rapid expansion creates openings w/20 leading financial inst. Prefer COBOL, large scale IBM. Accounting, banking or insurance exp. a plus. Refer DM.

FOR FURTHER INFORMATION ON EACH OF THESE FEE-PAID POSITIONS, CALL OR SEND RESUME TO THE RECRUITMENT SPECIALIST NEAREST YOU:

PHILADELPHIA, PA 19102—S. Bunn, 1500 Chestnut St., 215/561-6300
ATLANTA, GA 30316—R. Spang, 47 Perimeter Center, 404-393-0933
BALTIMORE, MD 21204—R. Nelson, 459 Washington Avenue, 301-296-4500
CHARLOTTE, NC 28202—J. Schaub, 1742 Southern Nat'l Ctr., 704-375-0600
CLEVELAND, OH 44104—A. Thomas, 1705 Orange Road, 216-749-6000
FORT LEE, NJ 07024—R. Mansfield, 2125 Center Avenue, 201-947-6920
MULLIN, VA 24104—C. Miller, 7321 Jones Branch Dr., 703-790-1335
NEW YORK, NY 10036—W. McNichols, 1211 Ave. of the Americas, 212-840-6900
PITTSBURGH, PA 15222—M. Beck, 4 Gateway Center, 412-232-0410
PRINCETON, NJ 08540—N. Davis, 3450 U.S. Rte. 1, 609/452-8135
WASHINGTON, DC 20040—C. Whitwell, 3411 Overseas Rd., 302-478-5150
HOUSTON, TX 77056—C. Lehman, 2812 South Post Oak, 713/677-1600

FOX-MORRIS
personnel consultants

CIRCLE 207 ON READER CARD

COURSES

DATACOMM SOFTWARE DESIGN

Software design for remote batch, message switching, time-sharing, transaction processing, packet switching, and distributed systems will be covered at both the applications and operating system levels. Classroom and workshop sessions both will be provided. Oct. 11-13 and Feb. 28-March 2 (1979) in Washington, D.C. Fee: \$430. Contact: Martha Augustin, Continuing Engineering Education, George Washington University, Washington, DC 20052 (800) 424-9773 or (202) 676-6106.

MINICOMPUTER APPLICATIONS

The course will attempt to cover the hidden costs of software, experiences in applying minis to business functions, the technical knowledge required to use minis well, evaluation of mini vendors, considerations of user company management and politics, software, implementation, and more. \$490. Oct. 9-11 in Dallas and Nov. 20-22 in New York. Contact: Claire Summer, American Management Associations, 135 W. 50th St., New York, NY 10020 (212) 586-8100.

SOFTWARE PHYSICS & CAPACITY MANAGEMENT

For those responsible for computer measurement activities for performance, workload forecasting, and equipment planning. Oct. 2-6 in Toronto, Oct. 16-20 in Minneapolis, Nov. 13-17 in Washington, D.C., and Dec. 11-15 in Phoenix. \$625 (\$375 for members of the Institute for Software Engineering). Contact: The Institute for Software Engineering, P.O. Box 637, Palo Alto, CA 94302 (415) 493-0300.

COMPUTER GRAPHICS

Carl Machower will conduct a course entitled "Knowing and Understanding Computer Graphics" in San Francisco Oct. 4-6 and in Chicago Dec. 13-15. Contact: Robert Sanzo, Frost & Sullivan, Inc., 106 Fulton St., New York NY 10038 (212) 233-1080.

DATAPRO SEMINARS

Datapro's fall course lineup includes the following subjects: Data communications (both an introductory and an advanced course are offered), data base management systems, word processing, integration of dp systems and word processing, effective computer operations management, computer performance

measurement, an introduction to data processing, organization communications for increased dp benefits and use, distributed systems, selection and use of minicomputers and small business computers, dp project management, network design, and understanding and purchasing proprietary software. \$485 (\$435 for Datapro subscribers). Contact: Datapro Research Corp., 1805 Underwood Blvd., Delran, NJ 08075 (800) 257-9406.

LASER BEAM INFORMATION SYSTEMS

The course will cover the application of laser technology to image and data manipulation in the forms of scanning, transmission, reproduction and control. Oct. 24-26 in Boston, Dec. 4-6 in Atlanta, and March 5-7 (1979) in Chicago. Contact: Heidi E. Kaplan, Dept. 20 NR, New York Management Center, 360 Lexington Ave., New York, NY 10017 (212) 953-7262.

CREATIVITY

"Creative Action in Engineering and Science" will present skills intended to help individuals improve their innovative capacity and to better recognize and accept change as an inevitable consequence of the passage of time. October

Programmer

Sperry Flight Systems is the Phoenix based International leader in automatic Flight Control Systems and Avionics for aircraft and space vehicles.

Currently we need a professional in our Information Systems Division.

Univac SYSTEMS SOFTWARE Programmer

Senior Systems Programmer responsible for Univac 1100 series executive System "EXEC" using Univac assembler language or "PLUS". We require a degree plus 2 years experience with Univac Systems Software.

Our system is a new large scale Univac 1100-40.

Our Information Systems environment offers an atmosphere for professional development in a growing organization.

Peripherals include medical and dental insurance, tuition refund and a stock plan.

For further information please send a resume including salary information to, Charles E. Melker, Professional Placement at:

SPERRY
FLIGHT SYSTEMS
P.O. Box 21111
Phoenix, Arizona 85036
Equal Opportunity Employer

If you currently earn between \$15,000 - \$36,000 we've got a better job for you ... NOW!

Several new contract awards have created numerous, immediate, long term career opportunities for degreed, technical professionals. We are only interested in top caliber, creative individuals with proven records of success in engineering, management & consulting.

Opportunities include technical/management consulting, project management, R&D, test and systems evaluation. Major contract areas include Communications, Satellites, Weapons, Intelligence, Computer, Energy and Aerospace systems. All positions require U.S. CITIZENSHIP, MINIMUM OF A BS degree (MS/Ph.D. preferred), and a minimum of one years' experience in one or more of the specific areas listed below.

- Software Design
- Data Base Design
- Telecommunications
- Minicomputers
- Programming
- Signal Processing
- Digital Systems
- Microprocessor Design
- Systems Architecture
- Applications
- Command & Control
- Systems Programming
- Compiler Design
- EW/SIGINT/ELINT
- MIS/OPs Research
- Diagnostics

If you want to join one of the fastest growing firms in the country, call Perri Reeder collect, at (301) 762-1100 or, if you prefer, send your detailed resume, in confidence. We'll make you an offer you can't refuse.

WALLACH
associates, inc.

1010 Rockville Pike
P.O. Box 2148
Rockville, Maryland 20852
(301) 762-1100

WALLACH ... Your career connection.
Equal Opportunity Employer Agcy.

16-18. \$300. Contact: C.W. Little, Jr., Univ. of Wisconsin Extension, Dept. of Engineering, 432 North Lake St., Madison, WI 53706 (608) 262-2061.

DATA BASE COURSES

Three separate courses are offered by PDC: Planning and Initiating the Data Base System Project, to be held Oct. 16 and 17 in Los Angeles and Nov. 13 and 14 in Houston; DBMS Packages: Comparison and Selection, to be held Oct. 18 and 19 in Los Angeles and Oct. 30 and 31 in New York; Data Administration/Data Dictionary, to be held Nov. 1 and 2 in New York and Nov. 15 and 16 in Houston. Each is \$375. Contact: Ms. Cheryl Palent, Performance Development Corp., 1101 State Road, Bldg. M, Princeton, NJ 08540 (609) 921-3770.

FAST FOURIER

A course on Modern Fast Fourier Transform Theory, to include techniques and applications, will be held in San Diego Oct. 16-18. Contact: Dr. Donald J. Rauch, Evelving Technology Seminars, 3720 Jennings St., San Diego, CA 92106 (714) 224-3788.

PERIODICALS

CUSTOMER NEWSLETTER

IMSAI Manufacturing Corp. offers a bi-monthly glossy publication "to establish communication with all the people who purchased IMSAI equipment, and as the capabilities, the usefulness and the performance of our product are improved or expanded, to make that information available." *The IMSAider* welcomes articles and letters from users concerning applications, software enhancements, experience with hardware, user groups, and seminars and events. \$4, yearly. IMSAI MANUFACTURING CORP., 14860 Wicks Blvd., San Leandro, CA 94577 (415) 483-2093.

PERSONAL COMPUTING

A monthly newsletter entitled *Personal Computing Industry Report* is now available. Its stated purpose is to provide reporting of observations, product announcements, market forecasts, interviews, insights, and industry analysis in a concise and relatively informal format. Regular departments will cover small business computing, semiconductor LSI, memory technology, retailing, software, peripherals, communications, trade shows, company profiles, and other areas. \$195 for a monthly subscription. VANTAGE RESEARCH, INC., 770 Welch Road, Suite 154, Palo Alto, CA 94304 (415) 965-4900.

MICROPROCESSOR NEWSLETTER

The Microprocessor Newsletter features a glossary for managers and corporate executives of "the basic terms necessary for communication with others in the field, i.e., manufacturers, engineers, etc." The newsletter provides news about micro users and makers, and features course information. Press releases about microprocessor ideas, applications and other news are solicited by the publisher. Yearly subscription is \$75. CARZO ASSOCIATES, 1210A King St., Wilmington, DE 19801.

INFORMATION TECHNOLOGY

A newsletter entitled *Impact: Information Technology* is Published by the Administrative Management Society, a nonprofit organization for professional managers, the newsletter will feature articles on the subjects of data processing, records management, reprographics, telecommunications, and word processing, with attention toward the integration of these fields. A monthly subscription is \$30. ADMINISTRATIVE MANAGEMENT SOCIETY, Maryland Road, Willow Grove, PA 19090 (215) 659-4300. *

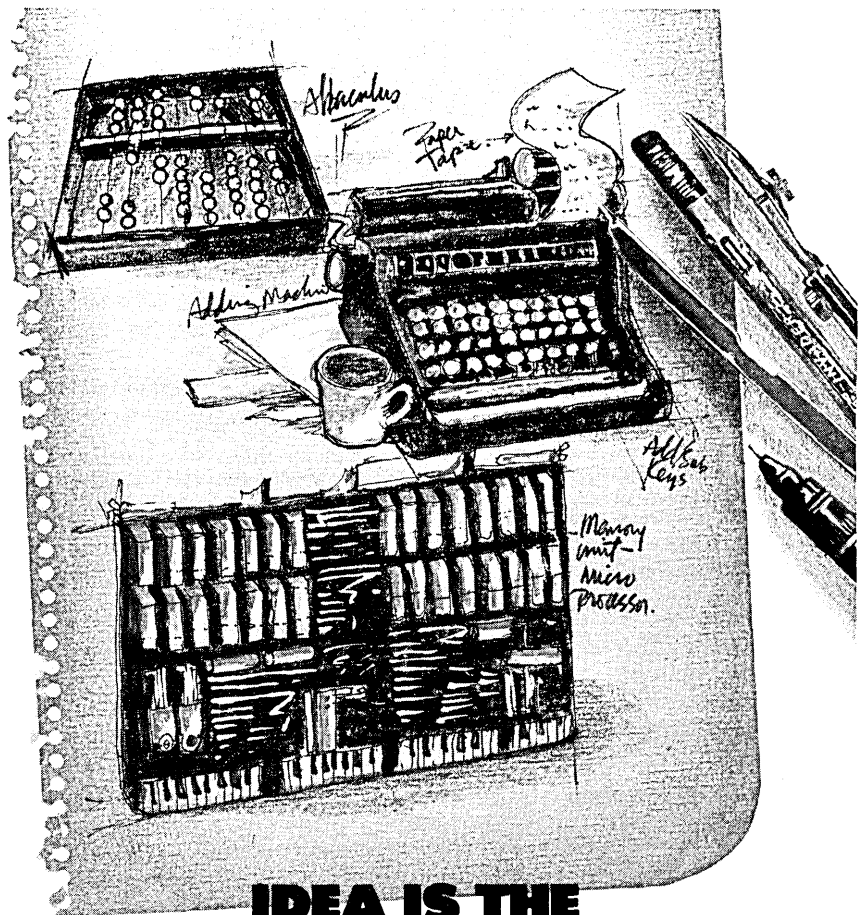

IDEA IS THE FOUNDATION OF INNOVATION.

And innovation is our client's stock in trade. We're LRK Associates and we represent one of the top 10 employers of creative hardware and software design professionals. If your experience matches the areas below, consider initiating a personal

dialogue with us now. We can introduce you to a multitude of long-range projects and programs that will prove not only financially rewarding and professionally stimulating, but will also afford you a tremendous measure of personal pride.

IMMEDIATE OPPORTUNITIES EXIST IN THE AREAS OF:

- Documentation Engineers
- Radar Software Development
- Simulation Design Engineers
- Mini-Computer Software Systems Design and Development
- Command & Decision Software Definition & Design
- Proposals Expertise For Large-Scale Systems
- Command and Control Software Development
- Micro-Processor Software Development
- Hardware/Software Integration
- Software Project Management
- Weapons Software Development
- Data Base Design

In The East:
703-790-8640
LRK Associates
Management Consultants
6845 Elm Street, Rm 5504
McLean, Virginia 22101

LRK
ASSOCIATES

U.S. Citizenship Required
representing equal employment opportunity M/F/H

In The West:
714-848-8494
LRK Associates
Management Consultants
16371 Beach Boulevard #141, Rm. 8402
Huntington Beach, CA 92647

CIRCLE 211 ON READER CARD

SOFTWARE ENGINEERS...

Where Does A Ground Floor Opportunity Really Start?

Anyone can talk ground floor, but a genuine opportunity of this nature should include certain elements. It should allow you to start close in and, as the operation expands, extend your skills and responsibilities into wholly new areas. It must take place in a dynamically expanding field like commercial telecommunications, where your innovative contributions can be matched by significant organizational growth. It must afford advancement to higher levels, in a shorter time-frame, than conventional organizations. Atlantic Operation gives you all this ... and more.

Only recently established, Atlantic Operation's primary objective is to design and develop real-time computer based systems to resolve unique problems within the

commercial telecommunications industry. To software engineers who join us now, we offer the total project involvement that only a young, dynamic organization can. You will contribute to every aspect of a project, from customer liaison and problem definition through final product development and user support. You'll employ such sophisticated software techniques as top-down analysis, code walk-throughs, and automated development tools.

You'll also benefit from a total visibility environment, where your work on state-of-the-art projects will have real-world impact on a global scale. Such projects include network management, digital switching support systems, common channel signaling,

automation of test sequences, operator call processing, centralized maintenance centers and other commercial applications.

We are looking at all levels for dedicated, talented software professionals with BS or MS degrees, real-time programming experience, and familiarity with languages such as PL-1, Assembly, ALGOL, or PASCAL.

Send resume and salary requirements to F. D. Brown, Sylvania Technical Systems, Inc., Atlantic Operation, 140 First Avenue, Waltham, Massachusetts 02154.

An Equal Opportunity Employer M/F

At The Atlantic Operation.

GTE SYLVANIA

ADVERTISERS' INDEX

AC Manufacturing Company	184	Dataram Corporation	167
Acme Visible Records, Incorporated	283	†Datsaab AB (Datsaab Division)	280-DD, 280-EE
†Agfa-Gevaert N.V.	280-GG	†Datsaab AB, (Stansaab Division)	280-X
Frank E. Alexander	188, 189, 190	Datum, Peripheral Products Division	Cover 3
Amecom Division, Litton Systems, Inc.	235	Dayco Corporation, Printing Products Division	68
American Computer Conference	285	Delta Data Systems Corporation	185, 187
American Management Systems	176	Dial Finance Company	98
American Terminal Leasing	286	Digital Associates Corporation	44
Ampex Memory Products Division	20	Digital Equipment Corporation	74, 75, 92, 93
Anadex, Inc.	255	Dranetz Engineering Laboratories	287
Anderson Jacobson, Inc.	96	Dyer, Wells & Associates Inc.	300
†Anritsu Electric Co., Ltd.	280-P	Eastman Kodak Company,	
Applications Software, Inc.	289	Business Systems Markets Division	232
Applied Data Research	5	Educational Enterprises	146
Applied Digital Data Systems Inc.	61	Electro Mechanics Division,	
Asiatic Petroleum Corporation	315	Wright Line Inc.	258
†Auerbach Publishers Inc.	280-I	Electronic Data Systems Corporation	292
Audiotronics, Video Display Division	67	Elgar	222
Autologic, Incorporated	115	Extel Corporation	152
Austron Inc.	97	Fenwal Incorporated	46
Aydin Controls	31, 229	Floating Point Systems, Inc.	265
Basic Four Corporation	135	FORTH, Inc.	48
BTI Computer Systems	72	Fox-Morris Personnel Consultants	315
Bell-Northern Research Ltd.	278, 279	Fujitsu Limited	47
†Benson	280-K	General Electric Company	324
Billings Computer Corporation	264	General Electric Co.,	
Boole & Babbage	311	Apparatus Service Division	330
Cable & Wireless Ltd.	21	Gould Inc.	280
California Computer Products, Inc.	62	Graham Magnetics	156
Cambridge Systems Group, The	107	Graphic Controls Corporation	28, 29
Capex Corporation	270	Graphic Resources Corporation	277
Centronics Data Computer Corp.	40	†Gretag Security Systems	280-F
Chromatics	32, 33	GTE Automatic Electric	320
Cincom Systems, Inc.	240	Harris Computer Systems	230, 231
†Codex Corporation	280-BB	Harris Corporation, Controls Division	291
Compugraphic Corp.	9	Harris Corporation,	
Computer Accessories Corporation	214	Data Communications Division	64, 65
Computer Communications, Inc.	76	Hazeltine Corporation	129
Computer Corporation of America	13	Hewlett-Packard	6, 7, 49-60, 142, 143
Computer Devices Inc.	157	Honeywell Information Systems	102, 103, 244, 245
Computer Professionals' Book Club	223, 224, 225	†Honeywell Information Systems Italia	280-N
Computer Sciences Corporation	326	IBM Data Processing Division	131, 132, 133
Comtal Corporation	12	ICC/Milgo	114
Continental Resources, Inc.	175	Info 78	297, 298, 299
Control Data Corporation	38, 39, 148, 259, 312	Inforex	86, 87
Custom Terminals Corp.	99	Informatics Inc.	109
Data General Corporation	178, 179, 238, 260, 261	Informatics Inc., Software Products	19
Data 100 Corporation	170, 171	†Infotech International Limited	280-LL
DatagraphiX Inc.	111	Infoton	177
Datamedia Corporation	183	†Infotron Systems Corporation	280-W
Datapoint Corporation	236, 237	Integrated Software Systems Corporation	69
Dataproducts	158, 159, 161, 163		

Tomorrow's Telecommunications Systems Are Demanding New Technology!

**CALL TOLL FREE
(800) 323-1966**

In Illinois (800) 942-0491 Monday thru Friday from
8am to 5pm cdt

**Complex
Software
Systems
Development**

**New
Concepts in
Firmware/
Hardware
Design**

**Massive
Computer
Controlled
Networks**

and that means exceptional career opportunity on the leading edge of a vast new technological frontier. GTE Automatic Electric is a world leader in this rapidly emerging new phase of one of the world's largest industries. You'll have the opportunity to advance your career in a highly professional environment...and working with concepts that are ahead of existing technology.

Highly visible, and promotable positions are available for software professionals who have above-average credentials in definition and design at advanced levels in the following

- Distributed Processing Architecture
- Computer Aided Design & Development
- AD/DA Systems Interface
- Top-down Systems Design
- Data Base Systems
- Real Time Systems
- Systems Diagnostics
- Signal Processing
- Stored Program Digital Systems
- Telecommunication switching and control systems (microprocessor or large CPU controlled)
- Large scale on-line systems management and executives
- Simulation
- Application Software

If you have recent experience in one or more of these areas and a BS, MS, or PhD in Electrical Engineering, Computer Science, Math or the equivalent in technical qualification and accomplishment, we would like to tell you more about this major expansion in our long term research and development program. We are committed to maintaining our position of leadership in this exciting new field; and a member of the GTE Family (ranked among the top R & D spenders in industry in 1976), can provide you with the support and resources to do the job.

If a telephone call is inconvenient at this time forward your resume, including recent salary history to: Manager of Technical Employment, Dept. 471 A6

GTE **AUTOMATIC ELECTRIC
LABORATORIES**

400 N. Wolf Road
Northlake, IL 60164
An Equal Opportunity Employer M/F

Make the Switch!

ADVERTISERS' INDEX

Interface Mechanisms, Inc.	8
International Computer Expo	191
International Data Sciences, Inc.	248
Interstate Electronics Corporation	327
Intertel	42, 43
Iowa Beef Processors, Inc.	301
Istel Corporation, Data Products Group	2
Kato Engineering Company	37
Kennedy Co.	Cover 2
Keuffel & Esser Company	95
Kybe Corporation	90
Lear Siegler, Inc., Data Products Division	181, 192
Leasametric, Division of Metric Resources Corporation	169
Lexitron Corporation	217
Liebert Corporation	30
Litton Computer Services	90
Lockheed Missiles & Space Company	301
†LogAbax OEM	280-M, 280-O, 280-Q
LRK Associates	317
Martin Marietta Data Systems	234
Megadata Corporation	254
†Memorex Corporation	280-KK, 280-MM
Methods Research	99
Micom Systems, Inc.	144
†Microtecnica	280-CC
Modular Computer Systems Inc.	16
Mohawk Data Sciences	101
Moore Business Forms, Inc.	66
Motorola Inc., Data Products	216
MRI Systems Corporation	45
Nanodata Corporation	160
National Semiconductor Corporation	112, 113
NCE Terminals & Communications, Inc.	91
NCR Corporation	276
NCR Corporation, Engineering & Manufacturing ..	308, 313
NEC Information Systems, Inc.	149
†Norsk Data Electronics A.S.	280-L, 280-HH
North-Holland Publishing Company	328
Ohio Scientific	63
Okidata Corporation	4
Omron Electronics, Inc.	77
On Line Hardware	285
Online Conferences Ltd.	296
Ontel Corporation	164
Oppenheimer and Co., Inc.	174
Pansophic Systems of Canada Ltd.	172
PCC Pertec, A Division of Pertec Computer Corporation	136, 137
Peripheral Dynamics Incorporated	218
Pertec Computer Corporation, CMC Division	1
Plessey Peripheral Systems	162, 210
Princeton Electronic Products, Inc.	35
Printronic, Inc.	205

Even Webster's Knows About QUEST

QUEST (kwest). v. 1. To make a search; to go on a quest.

QUEST SYSTEMS, INC. n. 1. A corporation founded in 1968. 2. The largest professional recruitment firm in the U.S. functioning solely in the computer sciences; its client companies pay all employment fees, interviewing and relocation expenses. Quest is known for its deep personal commitment to relate to each candidate as an individual with individual goals. 3. Its professional staff averages over 6 years of experience in EDP recruiting (additionally, staff members have direct hands-on experience in programming, systems, hardware sales, etc.) 4. Quest is presently searching for programmers and analysts (commercial, scientific, systems software) for over 3,500 client companies in the U.S. *Quest has openings in over 700 U.S. towns and cities.* 5. Methodology — see Questsystem.

QUESTSYSTEM (kwest sis'tem). n. 1. Discussing with an individual what he would like to be doing in light of what he has been doing. 2. Analyzing the realities of his objectives as they relate to the current job marketplace. 3. Contacting client companies and other Quest staff personnel to identify positions of possible interest. 4. Introducing the job candidate to his prospective employers by providing complete details to each about the other, ensuring the efficacious use of everyone's time. 5. Arranging interviews. 6. If employment offers are extended, Quest assists in evaluating the responsibilities, compensation and opportunities (and relates those to the initially stated objectives). The Questsystem has been working for thousands of professionals at no expense, whatsoever. Ask your friends of their past dealings with Quest. Then, put the Questsystem to work for you. For additional information on this subject, please inquire directly to Quest Systems, Inc. (All inquiries/resumes received will be responded to immediately and in confidence.)

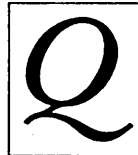

Call Toll Free
(800) 821-7700, Ext. 114
QUEST SYSTEMS INC.
6400 Goldsboro Road
Washington, D. C. 20034 (301) 229-4200
Baltimore: (301) 788-3500 • Philadelphia: (215) 265-8100

CIRCLE 214 ON READER CARD

PROGRAMMERS AND ANALYSTS

Free Employment Service

Serving Northeast, Southeast and Midwest U.S.

- Scientific and commercial applications
- Software development and systems programming
- Telecommunications
- Control systems
- Computer engineering
- Computer marketing and support

Call or send résumé or rough notes of objectives, salary, location restrictions, education and experience (including computers, models, operating systems and languages) to either one of our locations. Or check the reader service card for a free sample resume. We will answer all correspondence from U.S. citizens and permanent residents and will guarantee our best efforts in a professional and ethical manner to all qualified applicants that we think we can help. Our client companies pay all of our fees.

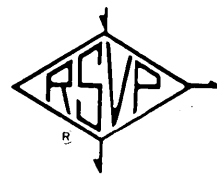

RSVP SERVICES, Dept. M
Suite 700, One Cherry Hill Mall
Cherry Hill, New Jersey 08002
(609) 667-4488

RSVP SERVICES, Dept. M
Suite 300, Dublin Hall
1777 Walton Road
Blue Bell, Penna. 19422
(215) 629-0595

RSVP SERVICES

Employment Agency for Computer Professionals

CIRCLE 213 ON READER CARD

If you know telecommunications...

Wang, a recognized leader in the business computer and word processing industries, is rapidly becoming a force in the telecommunications field. In 10 short years, we've grown to employ 4400 persons worldwide, billing nearly \$200 million; and have positioned ourselves as a major supplier of business industry, office management and word processing equipment. As we strive to enhance our momentum, we are looking for professionals who know the ultimate rewards that go along with hard work; talented professionals who want to explore and implement their ideas.

Telecommunications Marketing Specialist

If you have Armed Forces or Western Union communications experience with teletype message switching systems and would like to significantly participate in the application of advanced word processing systems in the administrative message environment, then this is the position for you.

This position provides for an opportunity for travel as well as direct contact with Fortune 500 customers, large financial institutions and major government agencies. You will be responsible for product support and specification of product enhancements through close liaison with corporate R & D.

Telecommunications Systems Analysts

These positions involve pre- and post-sales support, configuration analysis and installation and user training. Qualifications include: experience in the areas of modems, emulators and computer networks dealing with major account customers. Positions are available in major Eastern, Midwestern, and Western cities.

Programmers Telecommunications and Networking

We currently have positions available involving design, implementation, and continued enhancement of telecommunications and networking software. We also have positions involving the design and development of systems software for data communications between computer and word processing systems.

We offer excellent salaries and benefits. Please call Stephen E. Pitt, Manager Professional Recruiting, at (617) 851-4111, or send your resume to him at Wang Laboratories, Inc., One Industrial Avenue, Lowell, MA 01851.

We are an affirmative action employer

Get to know Wang.



Computers

WANG

Word Processing

ADVERTISERS' INDEX

Q1 Corporation	25
Quest Systems Inc.	321
Qume Corporation	208, 209
Racal-Milgo, Information Systems, Inc.	114
† Racal-Milgo Limited	280-U
Racal-Vadic	138
Realist, Inc.	34
RSI Inc.	98
RSVP Services	321
† R 2 E	280-V
Rusco Electronic Systems	271
Sanders Associates, Inc.	275
SAS Institute Inc.	36
† Scientific Research Associates Ltd.	280-JJ
† SE Labs (EMI) Limited	280-Z, 280-AA
Shugart Associates	207
† Siemens AG	280-R, 280-S
Siemens Corporation	150, 151
Sierra Data Systems	91
Software International	329
Sola, A Unit of General Signal	246
Sorbus Inc.	252
Source EDP	323
Spectron Corporation	247
Sperry Flight Systems	316
† SRA Communications AB	280-II
Summagraphics Corporation	180
Sycor	70, 71
Sylvania Technical Systems	318
Systems Engineering Laboratories	14, 15
Systonetics, Inc.	262
Tab Products Co.	263
Tally Corporation	213, 215
† Tandberg Data	280-D
T-Bar Data Communications Switching Division	251
Tektronix, Inc., Information Display Group	27, 294
Teletype Corporation	Cover 4
Texas Instruments Incorporated	147, 256, 273, 314
3M Company, Static Control Systems	269
Tion Equipment Company	264
Tower Systems, Inc.	186
TransNet Corporation	258
United Airlines Cargo	89
Universal Data Systems	253
University Computing Company	22, 23
Varian	10, 11
Versatec, A Xerox Company	110
Wallach Associates, Inc.	316
Wang Laboratories, Inc.	221, 322
Western Peripherals	193
Whitlow Computer Systems Inc.	26
Wright Line, A Subsidiary of Barry Wright Corp	249
Xerox Corporation	145
Xerox, Electronic Printing Systems	200, 201

New From Source Edp!

1978 Local Metropolitan Computer Salary Survey

Call for your FREE copy today!

Now you can compare your current salary with hundreds of other computer professionals working in or near your geographical area. Source Edp, North America's largest recruiting firm specializing in the computer field, has just compiled a timely survey of local salaries in the computer profession. The survey covers all areas of professional discipline in programming, software, information systems, marketing, etc. It shows salaries by length of experience, size of installation and includes all management levels. You can also compare your current compensation on a city by city basis with salaries paid in metropolitan areas across the U.S. and Canada as well as national averages.

For your FREE copy, call the Source Edp office nearest you.

East:

Boston
617/482-7613
Nashua NH
603/880-4047
Wellesley MA
617/237-3120
Hartford
203/522-6590
New York City
212/736-7445
Philadelphia
215/665-1717
Stamford CT
203/329-8411
Union NJ
201/687-8700
Washington DC
703/790-5610

Midwest:

Chicago
312/782-0857
Northfield IL
312/446-8395
Oak Brook IL
312/986-0422
Rolling Meadows IL
312/392-0244

Cleveland

216/771-2070
Detroit
313/963-0510
Southfield MI
313/352-6520
Kansas City
816/474-3393
Milwaukee
414/277-0345
Minneapolis
612/544-3600
Pittsburgh
412/261-6540
St. Louis
314/862-3800
St. Paul
612/771-0544

South/Southwest:

Atlanta
404/325-8370
Dallas
214/387-1600
Denver
303/773-3700
Fort Worth
817/338-9300

Houston

713/626-8705
New Orleans
504/561-6000
San Antonio
512/344-0217

West Coast:

Los Angeles
213/386-5500
Encino CA
213/995-8866
Irvine CA
714/833-1730
Torrance CA
213/540-7500
Palo Alto
415/328-7155
Portland OR
503/223-1131
San Diego
714/231-1900
San Francisco
415/434-2410
Seattle
206/454-6400
Canada:
Toronto
416/364-2919

source  edp

If unable to call, write: Source Edp, Department D-9
721 Enterprise Drive, Oak Brook, Illinois 60521

(When writing, please be sure to use home address and indicate position title.)

Openings in Rockville, MD:

• Computer Software Engineers • Systems Analysts • Communications Systems Designers

Openings Nationwide: Applications Programmers

Harness the power of an international network of 19 large-scale mainframes with state-of-the-art software.

Are you frustrated by limitations in the system you're now working with? There's no ceiling on creativity at GE. GE Information Services is built around a massive computer network, consisting of 19 large-scale mainframes (Honeywell and IBM with a 3033 on order) located in three interconnected data processing centers that serve 21 countries around the world.

Think of the possibilities. You can design new systems, develop modules for a proprietary operating system, innovate unique applications, even invent new languages, limited only by the scope and ingenuity of your conceptions. The sheer capacity and immense capabilities of the GE system invite state-of-the-art developments, since it can handle just about any conceivable program and any volume of data by the most sophisticated means you may devise.

Focus on your main interest . . .

To match the expansive facilities, the GE professional staff is large enough to permit your concentration on many areas of special interest, including:

- distributed data processing
- data communications networks
- microprocessing
- MVS internals
- on-line data base management
- major business applications
- operating system and compiler development
- command system and JCL design

. . . but keep a broad grasp on the rest of the EDP field.

You should never be trapped in one narrow specialty at GE. You can move from one project area to another, always keeping the total system in full view. That mobility, along with the range and variety of problems posed by GE's Fortune 500 customers, sharpens your skills and keeps you "state-of-the-art" on all sectors along the EDP front.

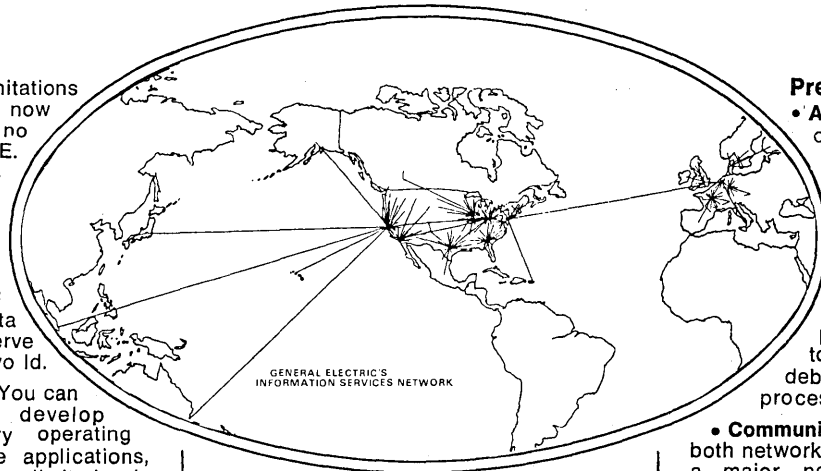

Present points of entry:

- **Application development**, for on-line order entry, financial reporting, data base, numerical control, and other business systems.
- **Operating system and compiler development**, for our proprietary MARK III® interactive systems including I/O drivers, logical file processors, memory allocators, TP monitor, compilers, debugging aids, and run-time processors.
- **Communication software**, including both network and terminal software for a major new distributed processing product.
- **System software internals** for our new MVS-based product line—including JES2, RACF, TSO, and RMF.

For the above-average professional with an extra spark of creativity and dedication, we have openings at all levels.

What makes Montgomery County, Maryland an ideal place for you and your family?

You'll find more than relaxed, rural-suburban living in the Montgomery County area. You'll find a "think-tank" environment. A short drive from Washington, D.C., you are in the heart of a cultural area, a prestigious community of professional, intellectual, and government leaders. Amid historical sites, museums, and the nation's preeminent fine arts centers, it's a stimulating environment for you and your family.

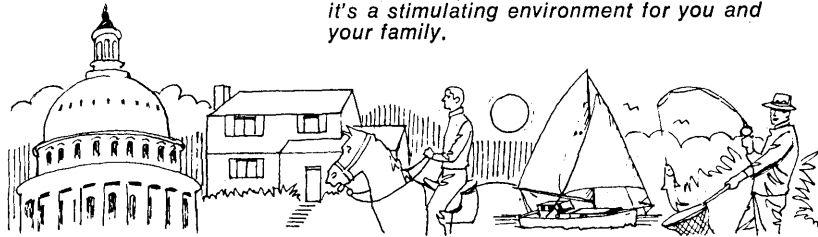

Send resume and salary history to: D. Donovan, Employee Relations, RM 65J, General Electric Information Services Business Division, 401 N. Washington St., Rockville, MD 20850.

GENERAL  **ELECTRIC**

An equal opportunity employer, m/f

ADVERTISING OFFICES

Eastern District Managers

A. Treat Walker,
Warren A. Tibbetts:
Greenwich, CT 06830
35 Mason St. (203) 661-5400
Telex 996343

New England District Manager &
Vice President

Warren A. Tibbetts:
Manchester, NH 03104
112 W. Haven Rd.
(603) 625-9498

Midwest District Manager

John M. Gleason:
Chicago, IL 60611
444 No. Michigan Ave.
(312) 644-3970

Western District Managers

Alan Bolte, Jr.:
Los Angeles, CA 90035
1801 S. La Cienega Blvd.
(213) 559-5111

James E. Filiatrault:

Mountain View, CA 94043
2680 Bayshore Frontage Rd.
Suite 401
(415) 965-8222

U.K., Scandinavia, Benelux

Intergroup Communications, Inc.
Wallace K. Ponder, European Director
Paul D. Dimmock, Regional Manager
31 Lyncroft Avenue
Pinner, Middx, HA5 1JU
England
Tel: (01) 868 9289
Cables: PACOM, Pinner

Germany, Austria, Eastern Europe

Fritz Taeuber
Soltauer Strasse 85
D-314 Lueneburg
Germany
Tel: (0 41 31) 4 38 49

France, Switzerland, Italy, Spain

Gerard Lasfargues
32 rue Desbordes Valmore
75016 Paris
France
Tel: (1) 288 90 22

Japan

Shigeru Kobayashi
Japan Advertising Communications, Inc.
New Ginza Building
3-13 Ginza 7-chome
Chuo-ku, Tokyo 104, Japan
Tel: (03) 571-8748

James B. Tafel, Chairman

John K. Abely, President

Robert L. Dickson, Exec. Vice President

Calverd F. Jacobson, Vice President-Finance

Walter Harrington, Vice President and Controller

TECHNICAL PUBLISHING COMPANY

A DUN & BRADSTREET COMPANY



Business Magazines

Consumer Books

Training Systems

Software Engineers:

Put New Challenge In Your Career!

Here is your chance to put NEW challenge and professionalism in your software career with fast-growing Litton Systems, Inc. AMECOM Division. New and expanded programs have given us our biggest backlog ever, and our work in state-of-the-art electronics technology guarantees new professional horizons for talented software engineers.

Investigate these opportunities:

DATA BASE SPECIALIST

You will develop data base structures, access schemata and DBMS operational procedures on large minicomputer based systems. You need at least 3 years experience in data base design including familiarity with Relational, Associative and Network data bases. PDP 11/RXS11 experience desirable. Background in ELINT data types, data distribution and security procedures helpful.

PDP 11 SPECIALISTS: SOFTWARE AND HARDWARE

You will develop and supervise integration and support of PDP 11 based systems with responsibilities to include OS modification, system installation at US sites, system integration and field maintenance of PDP 11 series processors and peripherals. You must be familiar with PDP 11 series processors and peripherals.

COMPUTER SYSTEMS ANALYSTS

Working as a Test Manager, you will function in our Software Independent Test Group designing software for an environmental simulator, write test procedures, test reports, and manage the programmers in the group. Computers used include the PDP 11/34, PDP 11/55, MODCOMP 11 and the LE4516. Languages include FORTRAN and Assembly. You need a secret clearance, 3 years previous computer experience and EE or EW experience desirable.

TEST PROGRAMMERS

You will program a real time minicomputer system using FORTRAN and Assembly languages. Amecom offers experiences on the PDP 11/45, LE4516, MODCOMP 11, IBM 370, Varian 620 and R&D on microcomputers. Hardware experience desirable.

AMECOM offers highly competitive salaries, excellent working environment with an innovative professional staff, and the opportunity to grow in your professional career.

For more information, please telephone or send your resume including salary history in confidence to:

Amecom Division
LITTON
SYSTEMS, INC.

Bill McAmis
(301) 864-5600

5115 Calvert Road
College Park, MD 20740
An Equal Opportunity Employer M/F/H

Ask Bob Steele why he recommends AUTODIN II as a "Growth Insurance Policy" for PDP-11 system software specialists.

☞ People with two to three years of experience in PDP-11 (and there are a lot of people with that kind of experience today), are enjoying a big demand for their talent. Obviously, this is largely the result of the booming popularity of the equipment.

☞ The big question is whether the individual wants to remain in a limited (but certainly rewarding) systems environment . . . or whether he or she wants to enter the mainstream of large scale, state of the art computer communications systems.

☞ AUTODIN II is certainly the coming thing; packet switching is the coming thing . . . and the general field of network and data switching, both for very high speed interactive traffic, and for large transfers of data — This is the technology that's going to be applied in many, many different networks in the future. So it is useful background to acquire, now.

☞ The truth is, there are precious few hands-on, solid projects like AUTODIN II out there. And at CSC, we're taking the technology forward and spreading it in twenty directions! So, if you come on board to work on AUTODIN II, you're still not locking yourself into a given project, no matter how challenging. And, more doors will be opening to you within CSC for the rest of your career!

☞ AUTODIN II exposes you to virtually every dimension of value — networking, communications software, packet switching, future expansion into other types of data communications, of terminal systems, interfaces to hosts, security and privacy in software, management techniques like top down structure programming, the need to become familiar with practically every type of computer and terminal that exists and insure it can interface this network. ☞

If you'd like to discuss current opportunities directly with Program Director Bob Steele, he will welcome your call on (800) 336-0429, or telephone him collect at (703) 533-8877.

Otherwise, you are invited to forward your resume in full confidence to Dianne Reason, Dept. 376

An illustrated design overview of AUTODIN II in addition to a variety of technical papers are also available with our compliments. Simply address your request to Dianne Reason, or to Bob Steele when you chat with him.

**WE AGGRESSIVELY SUPPORT
EQUAL OPPORTUNITY AND AFFIRMATIVE ACTION**

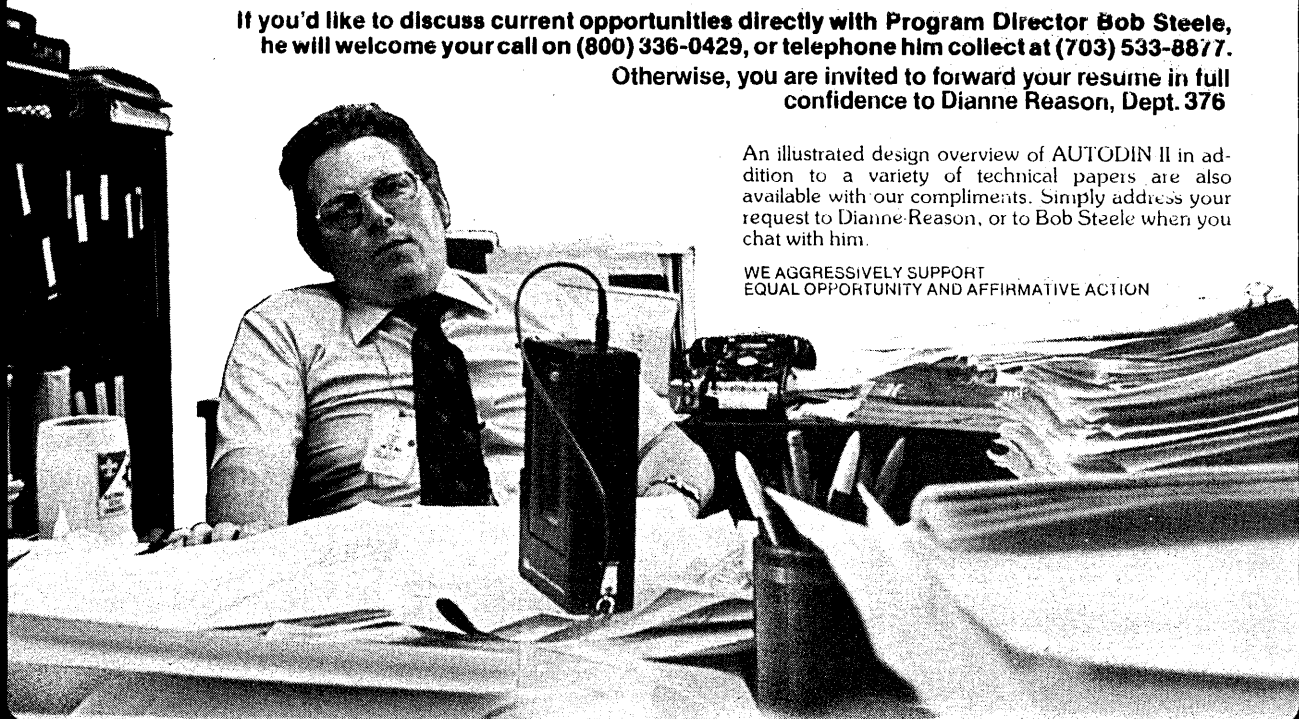

COMPUTER SCIENCES CORPORATION SYSTEMS DIVISION
6565 Arlington Boulevard Falls Church, VA 22046
Major Offices and Facilities Throughout the World.

FORUM

ARE SOFTWARE TAXES INEVITABLE?

If you received a \$92,000 back tax bill you didn't owe, how would you feel? It happened to two data processors and it put them out of business.

Rhoda Minowitz, an ex-elementary schoolteacher, and Jerry Salerno formed Queens Data Processing Inc. 10 years ago in Regal Park, N.Y. Queens Data had been a keypunch service grossing about \$360,000 a year until last year when the



state of New York decided that this little company should be assessed \$92,000 for back taxes. Threatened that they would be held personally liable, the two closed down the business.

The plight of Minowitz and Salerno is becoming a familiar story as taxing authorities in several states have moved unlawfully against data processors to squeeze out more tax dollars. All data processors, users and vendors alike, are exposed to a wide range of potential illegal taxes—sales taxes, use taxes, property taxes—some of which are completely unreasonable. The prevailing philosophy appears to be, "Let's tax it and see what happens."

For example, in 1976 the Tennessee Supreme Court ruled (in *Commerce Union Bank vs. Tidwell*) that software is intangible and nontaxable, but in 1977 and 1978 the Tennessee Legislature defined the identical software tangible and taxable.

In Rhode Island the state is asserting tens of thousands of dollars of tax liability, against Puritan Life Insurance Co.

Intelligent Voice Terminal can slash data-entry costs ...it's user programmable and operator compatible



It's direct source data entry by voice, no coding or keypunch. Interstate's Intelligent Voice Terminal adapts to your present information system without expensive modification to the host CPU. Better yet, this terminal adapts to the source-user in natural terminology, normal format. The Intelligent Voice Terminal does the rest. And it's available with a full line of hardware options and peripherals:

- **Expansion**—Additional voice channels, telephone-only station, industrial remote user subsystem.
- **Input**—Microphone, telephone, wireless microphone.
- **Feedback**—16 or 32 character display, large 40-character remote display, asynchronous serial device, audio response.
- **Mass Storage**—Cassette tape, linc tape with random access files, application control processor with disc, host computer.
- **I/O Peripherals**—CRT display, plasma display, serial printers, modem, keyboard printer.

Where do you use it? Any place you are considering using an intelligent keyboard terminal but where "hands free" or spoken language data input is an advantage. The cost-reduction benefits can be highly significant. Call or write Daniel F. Fink, Marketing Manager, Voice Products, Interstate Electronics Corp., 1001 East Ball Road, P.O. Box 3117, Anaheim, CA 92803, (714) 635-7210.

**INTERSTATE
ELECTRONICS
CORPORATION**

SUBSIDIARY OF **ATO**

Information Processing and Display.
Systems. Products. Services.

To all who can read and to all who can write

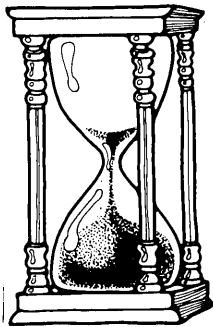

IMPORTANT INSIGHT 1974
RESULTS COMPLETELY ON PAPER 1976
SUBMITTED TO JOURNAL 1976
RESUBMITTED WITH CHANGES 1977
ACCEPTED FOR PUBLICATION 1978
PAPER PUBLISHED 1979

You as a professional know that this is no horror story. It happens every day in many journals focusing on information processing. Authors and readers alike are the victims of these wasteful practices.

We think we have solved the problem at our end. You could call it our specialty. Check us. Consider IPL.

INFORMATION PROCESSING LETTERS

devoted to the rapid publication of short contributions to information processing

RELEVANCE, QUALITY & SPEED

recently published:

- "Sorting by distributive partitioning" (DPS)
W. Dobosiewicz; (high-lighted in "DATAMATION", February 1978)
- "A more efficient convex hull algorithm"
J. Koplowitz, D. Jouppi
- "Divide and conquer for linear expected time"
J.L. Bentley, M.I. Shamos
- "Insertion merge sorting"
E. Peltola, H. Erkiö
- "An improved algorithm to check for polygon similarity"
S.G. Akl, G.T. Toussaint
- "An optimal demand prepaging algorithm"
R.K. Aurora, R.K. Subramanian
- "Comments on "Sorting by distributive partitioning"
W. Burton + Author's reply to these comments by
W. Dobosiewicz

In 1978, IPL is published in one volume of six issues. Subscription price: \$58.50. (post-paid).

I DON'T BELIEVE IT

so send me with all the efficiency you claim a
FREE INSPECTION COPY OF I.P.L.

To: North Holland Publishing Company P.O. Box 211,
 1000AE Amsterdam, The Netherlands

Name: _____

Address: _____

IPL - Datamation - Sept 78

CIRCLE 191 ON READER CARD

FORUM

for one, for the *use* of applications programs, while the state's tax statute expressly limits the tax to operating system programs "needed to make the computer operate." Thus applications programs are being classified as operating system programs—retroactively no less!

Usually the problem boils down to whether software is tangible or intangible. Unfortunately, the courts and taxing bodies haven't been educated to the true nature of software. Finding cards and magnetic tape to be quite tangible, they have often determined that software is open to taxation. The counterargument is already there, in the law, however; we must simply learn how to find it and how to use it.

For example, accountants, lawyers, doctors, typists, etc., all generally enjoy intangible tax exempt status for their work products. Similarly, the typed sheet of a secretary is classified as intangible and not taxable. But the same typed sheet read by a computer is classified as tangible and taxed. The input paper tape of a court reporter is generally classified as intangible, while the input paper or mag tape for a computer is classified as tangible. (However, the same computer tape used to carry output is generally classified as intangible. How's that?)

A TAX FOR EVERY OCCASION

Whether you're a seller, buyer, user, or employee the software sales tax issue affects you. However, the sales tax on software is just the beginning. Where there is a sales tax, there is a use tax. That can extend the tax into the users' laps—even a tax *within* companies on the internal services of data processors. (It's being tried.) If the tax arises under statutes authorizing a tax on tangible personal property, as in most states taxing software, the property tax man can be next. And property tax can amount to 50% of the original cost of computer software over a 10 year period.

There are various ways in which a sales tax on software can be created. It could arise through an adverse court decision or legislative lawmaking. For the most part, however, this form of taxation evolves through the rule-making authority of a state agency empowered to administer the state sales tax law. Generally, the law itself provides for the taxation of things corporeal, and the agency arbitrarily classifies software as tangible personal property without properly considering the facts.

For example, California, where it all began, has been imposing an irrational tax on data processors for several years. The reason the tax appears irrational is that the rule itself levying the tax, rule 1502, expressly and specifically exempts the product of programmers, analysts, and technical help. Many firms have fought the tax, but the cases have been kept to individual terms. Thus, up to now California has successfully prevented data processors from achieving any general administrative or judicial remedy of the problem.

On May 4th all that might have changed. After the successful completion of a similar action in New York, a California group called STAG (Sales Tax Action Group) was granted a formal, administrative, rule-making hearing by the State of California. Data processors and their attorneys, however, faltered. After less than two hours, the state was allowed to end the much-awaited hearing before all witnesses were heard. Why had the industry again failed to present a complete, favorable and appealable record before continuing private discussions?

The answer lies in a fallacious belief that deference to agency desires at the expense of due process will win special favor. In reality the acquiescence constitutes a surrender of valuable Fourteenth Amendment rights: the right to reasonable government action, the right to a rational classification under the law, and the right to judicial review.

By agreeing to terminate the hearing before its conclusion, data processors deprived themselves of any judicial review of that particular agency action they might have invoked. Meanwhile, they must continue paying taxes that are

in many cases unlawful; and by the time the tax is ruled invalid—if ever—much of the monies paid into government will have been cut off from them by the statute of limitations.

The dp industry doesn't always lose, however. Eight states have changed their classification of software to intangible and nontaxable since last year: Alabama, Florida, New Jersey, New York, Vermont, Louisiana, Minnesota, and Wisconsin. The catalyst for these actions is the 1976 Tennessee Tidwell Supreme Court decision, which is as noteworthy for its breadth as it is for its declaration of intangibility. For the first time, a state Supreme Court included all of computer input—"information and directions . . ."—in the intangible classification, not just programs.

Yet nowhere do the facts mock reason more than in Tennessee. The state's ploy of calling intangible software tangible was first introduced into law in 1977 by adding software to the definition of tangible personal property. In 1978 the law was amended by moving software into the sales tax category, purportedly for the purpose of selectively removing it from the use tax. Now software is both intangible and tangible in Tennessee at the same time, depending on whether a sales or a use tax is under consideration!

Tennessee's own legislative deliberations show the tax is flagrantly unreasonable and irrational. The deliberations of March 16, 1977 on the original bill hold clearly that software constitutes professional services, much the same as law and accounting, and that software should be accorded the same treatment under the tax law as other professions; yet despite a constitutional right to a rational classification, the legislature ignored its own findings and classified software as tangible and taxable anyway:

Senator Hamilton (sponsor of the bill): "Mr. Speaker. Members of the Senate. This bill would include computer software within the definition of tangible personal property contained in the state sales tax statutes . . . Under this bill, the sale of computer tapes and cards containing programs would be taxable. Pending any questions, Mr. Speaker, I move its passage on it."

Senator Higgs: "I find some inconsistency coming from . . . the revenue department wanting to exempt professional services from a tax . . . But software is computer programming and it is the expertise of the programmer of professional services that you're fixing to put a tax here. Now the cards and tapes so far have always been taxable. So I'm beginning to wonder what the revenue department and administration are thinking over there."

Senator Hamilton: "Well, I can tell you this, that under the recent court ruling computer tapes and stuff cannot be taxed as tangible personal property and this (the bill) in effect was supposed to remedy that situation where we actually kept in practice that which we had been practicing for years."

Senator Higgs: "Well, we've been paying sales tax on tape, bunch of tape and stuff, for as long as I've known. Even the rent of the computer is taxed. But the programming itself, which is the professional services of an individual, much the same as an attorney or an accountant or an anthropologist, ah, it comes from inside his head, he puts it down in a formula, and if we're going to tax these professional services, maybe we ought to put them all under."

Senator Hamilton: "I couldn't agree with you more on that."

Speaker of the Senate: "Is there any further discussion? . . . Take the poll. Ayes - 23. No - 4. 32 not voting. Senate Bill 224 having received constitutional majority and let it pass."

At this point, Tennessee's lawmakers have conceded software is a professional service but, inexplicably, have simultaneously classified that service as tangible.

In doing so, Tennessee has set a clear precedent for others to follow as California had done years before. Tennes-

KNOW THE SCORE!



Fixed Asset Accounting Removes the Blindfold

When accounting users look after fixed assets, you can open their eyes to a much clearer picture. Just install the new Fixed Asset Accounting System, from Software International.

You'll be able to provide *complete* asset and property control data, consistent with latest accounting techniques. And our Fixed Asset Accounting System satisfies *all* IRS and SEC reporting requirements.

Best of all, Fixed Asset Accounting is from the *leader* in financial application software packages. More than 1400 major-league corporations around the world consider Software International the home team.

Give your users the Fixed Asset Accounting System. It's the heavy hitter that will make *you* a champion.

Before I swing and miss with a minor-league Fixed Asset Accounting System, tell me more about:

SMALL COMPUTER SYSTEMS

- General Ledger and Financial Reporting Accounts Payable
 Accounts Receivable Fixed Asset Accounting

LARGE COMPUTER SYSTEMS

- Financial* General Ledger and Financial Reporting
 Accounts Payable Accounts Receivable
 Fixed Asset Accounting

- Manufacturing* Material Requirements Planning
 Master Production Scheduling Capacity Planning
 Shop Floor Control Purchasing

Comprehensive Report Generator FILETAB

Name _____ Title _____

Company _____

Address _____ Phone _____

City _____ State _____ Zip _____

Computer System _____

SOFTWARE INTERNATIONAL®

Elm Square, Andover, Mass. 01810 (617)475-5040
Atlanta • New York • Washington, D.C. • Philadelphia • Chicago • San Diego
Toronto • Houston • Columbus, OH • San Francisco

SPECTRON DATASCOPE FOR RENT FROM GENERAL ELECTRIC

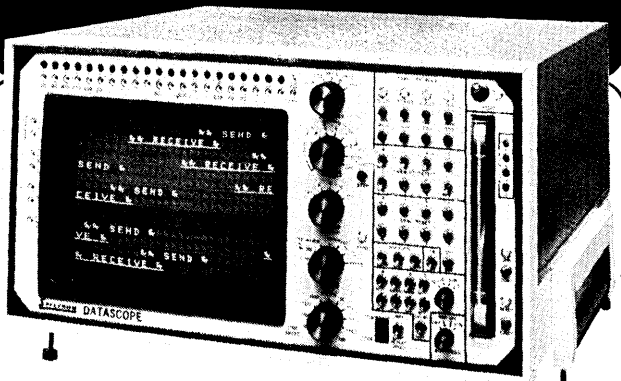

Diagnose Data Communications System Problems In Seconds

- CRT display of every character. • All-line compatibility.
- Hardware/software diagnosis. • Portable, easy to use.

Quick-rental[®] instruments

- Rent by the week, month or year.
- Fast delivery
- Applications assistance.

For more information on the Spectron Datascope and a free 68-page catalog of rental test instruments call your nearest sales office listed below or write General Electric Co., Apparatus Service Division, Bldg. 4, Room 210, Schenectady, N.Y. 12345.

ALA. BIRMINGHAM (205) 925-9449 • ARIZ. PHOENIX (602) 278-8515 or 8516, TUCSON (602) 294-3139 • CAL. LOS ANGELES (213) 642-5350, SACRAMENTO (916) 383-4986, SAN FRANCISCO (415) 436-9260 • COL. DENVER (303) 320-3255 • CONN. SOUTHWINGTON (203) 621-4059 • FLA. JACKSONVILLE (904) 751-0615, MIAMI (305) 696-0811 • GA. ATLANTA (404) 457-5563 • ILL. CHICAGO (219) 933-4500 or (312) 854-2994 • IND. INDIANAPOLIS (317) 639-1563 • KY. LOUISVILLE (502) 452-3311 • LA. NEW ORLEANS (504) 367-6528 • MD. BALTIMORE (301) 332-4713 • MASS. BOSTON (617) 396-9600 • MICH. DETROIT (313) 285-6700 • MINN. MINNEAPOLIS (612) 522-4396 • MO. KANSAS CITY (816) 231-4377 or (816) 231-4620, ST. LOUIS (314) 965-7115 • NEW JERSEY CLIFTON (201) 471-6556 • N.Y. BUFFALO (716) 876-1200, SCHEMECTADY (518) 385-2195 • N.Y.C. CLIFTON, N.J. (201) 471-6556 • N.C. CHARLOTTE (704) 925-6311 • OH. CINCINNATI (513) 574-8512, CLEVELAND (216) 441-6111, TOLEDO (419) 691-3501 • ORE. PORTLAND (503) 221-5101 • PA. PHILADELPHIA (609) 424-4450, PITTSBURGH (412) 462-7400 • S.C. GREENVILLE (803) 277-4093 • TENN. MEMPHIS (901) 527-3709 • TEX. BEAUMONT (713) 842-4514, DALLAS (214) 357-7341, HOUSTON (713) 672-3570 • VA. RICHMOND (804) 232-4576 • WASH. SEATTLE (206) 854-0211 • W.V. CHARLESTON (304) 345-0920 • WISC. MILWAUKEE (414) 744-0110 • PUERTO RICO PONCE (809) 843-4225 or 4625.

GENERAL  ELECTRIC

CIRCLE 178 ON READER CARD

FORUM

see is teaching other states how to turn the dp industry's victories into defeats through the arbitrary redefinition of words, as California had first shown the states how to tax us under statutes authorizing a tax on tangible personal property.

My interest in software's legislative history in Tennessee is deeply rooted. It was during the time of my fight with Florida in 1976 against the \$45,000 retroactive assessment the state had levied on me (*Nova Computing Services, Inc. vs. Askeu*) that the Tennessee Tidwell decision was handed down. While the opinion was not binding on Florida, the hearing officer in my case found it persuasive. Thus, it helped tip the scales in Florida, as it has in other states since then.

FOLLOW RHODE ISLAND

A powerlessness to remedy my \$45,000 assessment except through spending \$50,000 for lawyers' fees forced me into this issue. A view of how poorly data processors are represented in such cases has kept me involved. Fortunately, that representation can be improved.

Unlike many actions to date, the Rhode Island case (*Puritan Life Insurance Co. vs. Dept. of Revenue*) shows the benefit of close cooperation between lawyers and laymen. For three days prior to the hearing in April, data processors and their counselors huddled in intensive preparation. The hard work paid off in pinpoint examination during the hearing, leading to recorded testimony which finally puts on the record a meaningful description of what software is.

The testimony hasn't led to a victory for us, yet, but when the Rhode Island case is decided it will be decided on the record, not on governmental whim. Even if the case goes against us, the record may show enough in our favor for appeal to federal courts under the Fourteenth Amendment. That's not a guaranteed win either, but at least it's another chance.

Just as the Tennessee and California examples have shown other states how to get away with levying taxes on the sale of software, the Rhode Island case shows how the dp industry can fight back—by educating the lawyers and courts, and by standing up for its rights. But to do this, the data processing industry must educate itself. It must become aware of the nature and size of the problem, and then, somehow, come to a consensus and unite on the issue. The alternative is to sit back, as we are, and watch as sales, use, and property taxes—and perhaps others—are levied on those software products which are sold to us and those which we build for our own use.

The amount of money we are talking about is substantial. It is not just 5% or 6% on top of a sale; it may amount to 50% of a product's value or more over the life of the product. That is worth fighting over.

Mr. Sherin is the president of Nova Computing Services, Inc., in Miami, and a paralegal with the law firm of Jack Large in Ft. Lauderdale. He also acts as a nonjudicial legislative advisor to the DPMA.

— Robert M. Sherin

Perform a death-defying act.

Exercise regularly.

Give Heart Fund 
American Heart Association

Datum the Intelligent Alternative for PDP-11 Disk Users

Price

- Significant cost savings for OEMS and End users.
- Dollar for dollar Datum offers you the lowest possible cost per byte without sacrificing performance or dependability.

Dependability

- More than 9 years of designing and selling peripheral systems. Over 10,000 peripheral products installed, has made Datum the leading independent supplier of peripheral systems.
- With major service centers in the United States and Europe, Datum is prepared to service its products worldwide with direct factory trained personnel.
- Utilizes the same microprocessor technology used in our larger capacity disk systems.

Performance

- Complete Software & Media transparency to the DEC RK11
 - Mix or Match Drive capacities at speeds of 1500 or 2400 RPM
 - Single board design, occupying 1 SPC slot of a DD11-A (or equivalent) System Unit
 - 34 byte data buffer
 - Controls up to four 2.5, 5 or 10 megabyte disk drives
 - Interfaces to drives manufactured by Diablo, Pertec, Western Dynex, Wangco, Caelus & DRI
- 11 reasons we want you to look at our disk products for your PDP-11 computer.

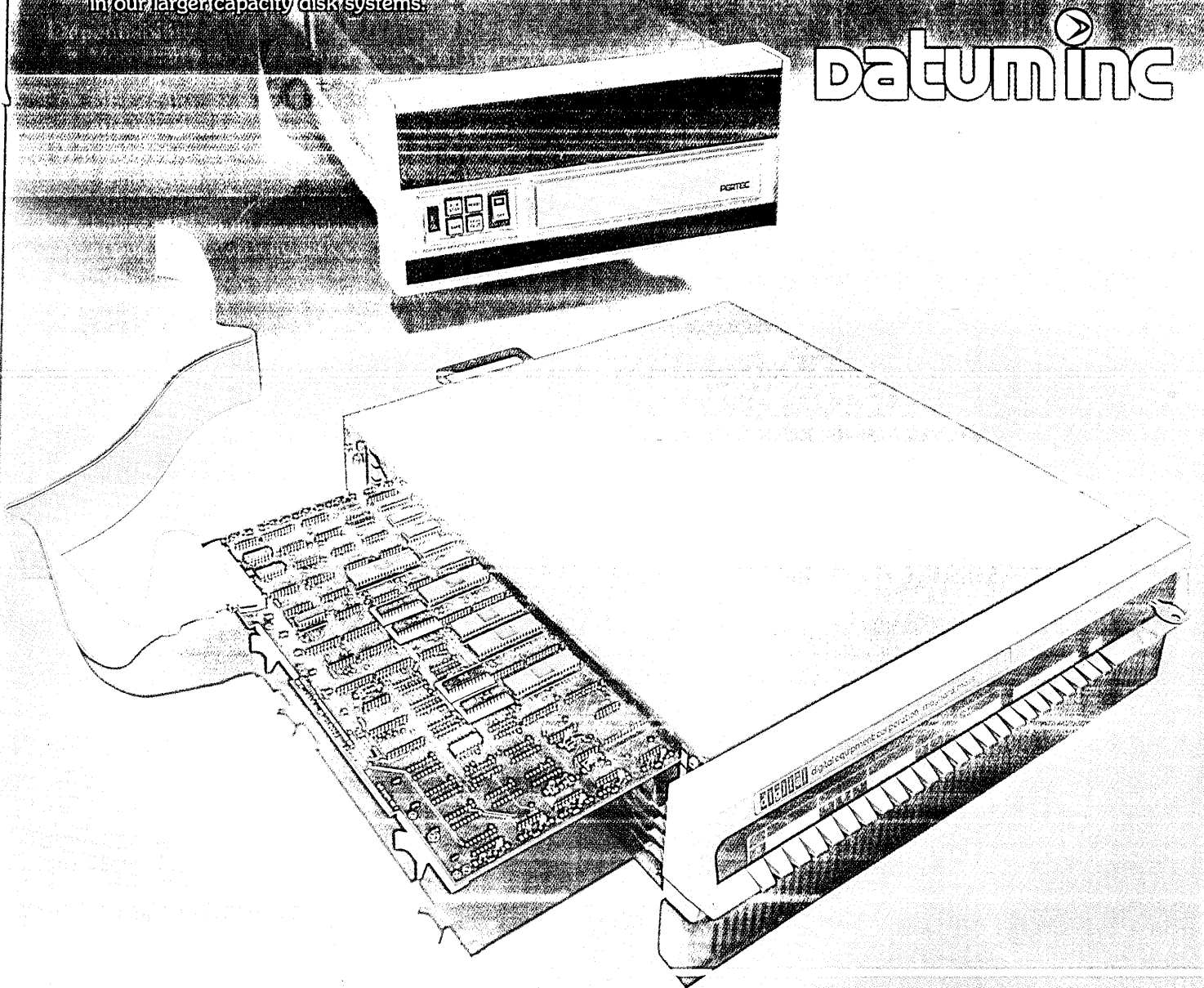

Datum inc

WE'D LIKE TO REMIND YOU ABOUT THE DATA COMMUNICATIONS TERMINAL OUR COMPETITORS WOULD LIKE TO FORGET.



What the bottom line is telling banks, brokerage houses, pharmaceutical chains, railroads and steel companies is that for all-around value, there's no way the Teletype* model 40/4 synchronous data terminal can be beaten.

And no wonder. Over the years, Teletype data terminals have built up an outstanding reputation for quality, dependability and proven performance. Add to that the model 40/4's system flexibility and human engineering features and you'll see why it consistently comes out on top in competitive analyses.

There's even icing on the cake. Delivery is only 30 to 90 days. And model 40/4 systems are installed and maintained by Teletype's nationwide service network.

So if you're looking for stand-alone or clustered displays and printers that are hardware and software compatible with remote bisynchronous communications protocol, command code structures and addressing sequences, we'd like you to look at the

model 40/4. And to make that easy, we're offering a free, on-site evaluation program. In other words, we're putting our money where our mouth is.

Just give us a call at 312/982-2000, or send in the coupon below. But do it quickly, please. Because with something as hot as the 40/4, we don't have many just sitting around.

*Teletype is a trademark and service mark of the Teletype Corporation.

Teletype Corporation
5555 Touhy Avenue
Dept. 3185
Skokie, IL 60076



Your free, on-site evaluation program sounds intriguing, and I'd like to know more about it.

Name _____

Position _____

Company _____

Address _____

State _____ Zip _____

Phone _____