

TOSHIBA BIPOLAR LINEAR INTEGRATED CIRCUIT SILICON MONOLITHIC

TA7259P, TA7259P(LB), TA7259F

DC MOTOR DRIVER IC

The TA7259P is a 3-phase Bi-directional motor driver IC. It designed for use VTR tape deck, floppy disk and record player motor drivers.

It contains output power drivers, position sensing circuits, control amplifier and CW/CCW control circuit.

FEATURES

- 3-phase Bi-directional driver and output current up to $\pm 1.2A$.
- Few external parts required.
- Wide operating supply voltage range : $V_{CC}(\text{opr.})$ MIN. = 7V
- Forward and reverse rotation is controlled simply by means of a CW/CCW control signal fed into FRS.
- High sensitivity of position sensing amplifier.
($V_H = 10mV$ (Typ.), recommend to use TOSHIBA Ga-As hall sensor "THS" series.
- Surge protect diode connected for all input terminals.
(Position sensing, control, CW/CCW control inputs.)
- DIP-14F power package.

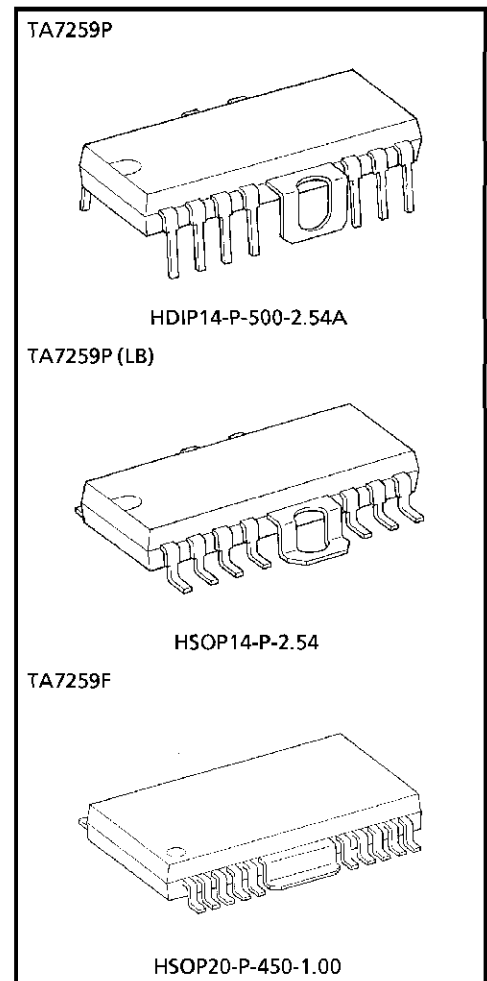

Weight
 HDIP14-P-500-2.54A : 3.00g (Typ.)
 HSOP14-P-2.54 : 3.00g (Typ.)
 HSOP20-P-450-1.00 : 0.79g (Typ.)

961001EBA1

- TOSHIBA is continually working to improve the quality and the reliability of its products. Nevertheless, semiconductor devices in general can malfunction or fail due to their inherent electrical sensitivity and vulnerability to physical stress. It is the responsibility of the buyer, when utilizing TOSHIBA products, to observe standards of safety, and to avoid situations in which a malfunction or failure of a TOSHIBA product could cause loss of human life, bodily injury or damage to property. In developing your designs, please ensure that TOSHIBA products are used within specified operating ranges as set forth in the most recent products specifications. Also, please keep in mind the precautions and conditions set forth in the TOSHIBA Semiconductor Reliability Handbook.
- The products described in this document are subject to foreign exchange and foreign trade control laws.
- The information contained herein is presented only as a guide for the applications of our products. No responsibility is assumed by TOSHIBA CORPORATION for any infringements of intellectual property or other rights of the third parties which may result from its use. No license is granted by implication or otherwise under any intellectual property or other rights of TOSHIBA CORPORATION or others.
- The information contained herein is subject to change without notice.

BLOCK DIAGRAM

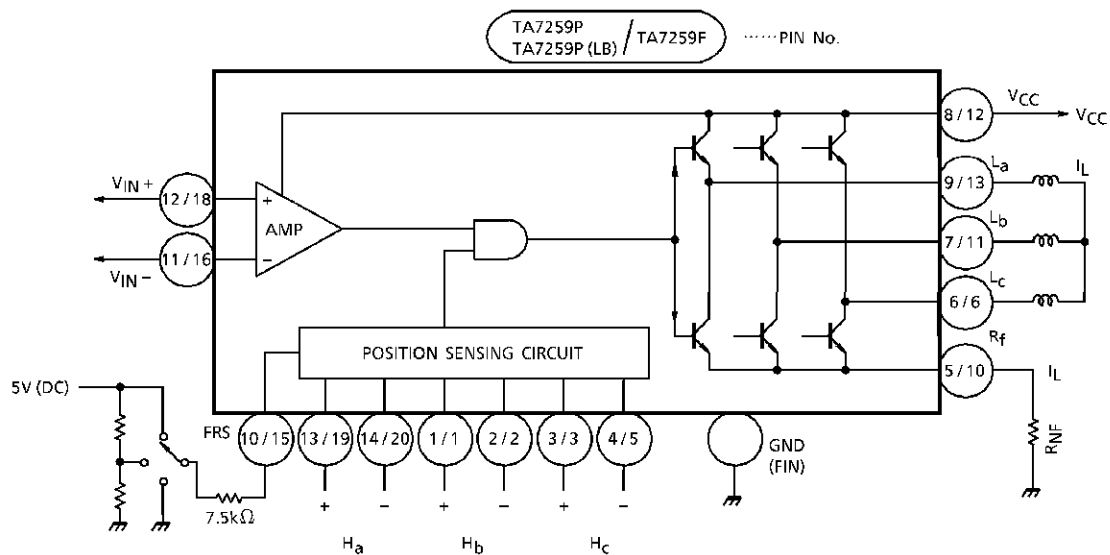

PIN FUNCTION

PIN No.		SYMBOL	FUNCTION DESCRIPTION
P TYPE	F TYPE		
1	1	H _b +	b-phase Hall Amp. positive input terminal
2	2	H _b -	b-phase Hall Amp. negative input terminal
3	3	H _c +	c-phase Hall Amp. positive input terminal
4	5	H _c -	c-phase Hall Amp. negative input terminal
5	10	R _f	Output current detection terminal
6	6	L _c	c-phase drive output terminal
7	11	L _b	b-phase drive output terminal
8	12	V _{CC}	Power supply input terminal
9	13	L _a	a-phase drive output terminal
10	15	FRS	Forward / Reverse / Stop switch terminal
11	16	V _{IN} -	Control Amp, negative input terminal
12	18	V _{IN} +	Control Amp, positive input terminal
13	19	H _a +	a-phase Hall Amp. positive input terminal
14	20	H _a -	a-phase Hall Amp. negative input terminal
Fin	Fin	GND	GND Terminal

FUNCTION

FRS (10 PIN)	POSITION SENSING INPUT			COIL OUTPUT		
	H _a	H _b	H _c	L _a	H _b	L _c
L	1	0	1	H	L	M
	1	0	0	H	M	L
	1	1	0	M	H	L
	0	1	0	L	H	M
	0	1	1	L	M	H
	0	0	1	M	L	H
H	1	0	1	L	H	M
	1	0	0	L	M	H
	1	1	0	M	L	H
	0	1	0	H	L	M
	0	1	1	H	M	L
	0	0	1	M	H	L
M	1	0	1	High Impedance		
	1	0	0			
	1	1	0			
	0	1	0			
	0	1	1			
	0	0	1			

MAXIMUM RATINGS (Ta = 25°C)

CHARACTERISTIC		SYMBOL	RATING	UNIT
Supply Voltage		V _{CC}	26	V
Output Current		I _O	1.2	A
Power Dissipation (Note)	TA7259P	P _D	2.3	W
	TA7259P (LB)		2.3	
	TA7259F		1.0	
Operating Temperature		T _{opr}	-30~75	°C
Storage Temperature		T _{stg}	-55~150	°C

(Note) No heat sink.

ELECTRICAL CHARACTERISTICS (Unless otherwise specified, $V_{CC} = 12V$, $T_a = 25^\circ C$)

CHARACTERISTIC		SYMBOL	TEST CIR-CUIT	TEST CONDITION	MIN.	TYP.	MAX.	UNIT
Quiescent Current		I_{CC1}	—	FRS open	2	4	7	mA
		I_{CC2}		FRS = 5V	2	5	9	
		I_{CC3}		$V_{CC} = 22V$, FRS = GND	2	5	9	
Input Offset Voltage		V_{IO}	—	—	—	40	—	mV
Residual Output Voltage		V_{OR}	—	$V_{IN-} = V_{IN+} = 7V$	—	0	10	mV
Voltage Gain		G_V	—	$R_{NF} = 2.2\Omega$	—	15.0	—	—
Saturation Voltage	Upper	V_{SAT1}	—	$I_L = 400mA$	—	1.0	1.5	V
	Lower	V_{SAT2}	—		—	0.4	1.0	
Cut-off Current	Upper	I_{OC1}	—	$V_C = 20V$	—	—	20	μA
	Lower	I_{OC2}	—		—	—	20	
Position sensing Input Sensitivity		V_H	—	—	—	10	—	mV
Maximum Position Sensing Input Voltage		$V_H \text{ MAX.}$	—	—	—	—	400	mV _{p-p}
Input Operating Voltage	Position	CMR_H	—	—	2.0	—	$V_{CC} - 2.5$	V
	Control	CMR_C	—	—	2.0	—	$V_{CC} - 2.5$	
Rotation Control Input Voltage	CW	V_F	—	—	—	0	0.4	V
	STOP	V_S	—	—	2.5	3.0	3.5	
	CCW	V_R	—	—	4.5	5.0	5.8	

INPUT vs OUTPUT

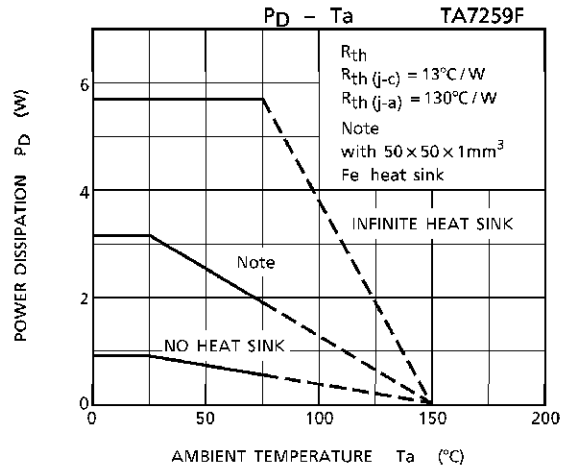
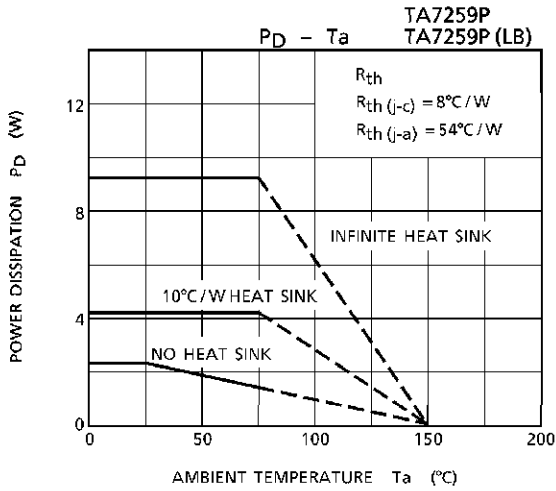
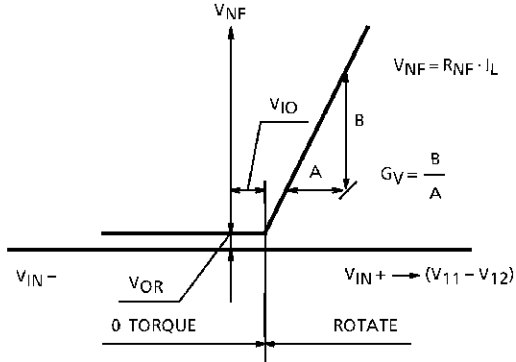

APPLICATION CIRCUIT

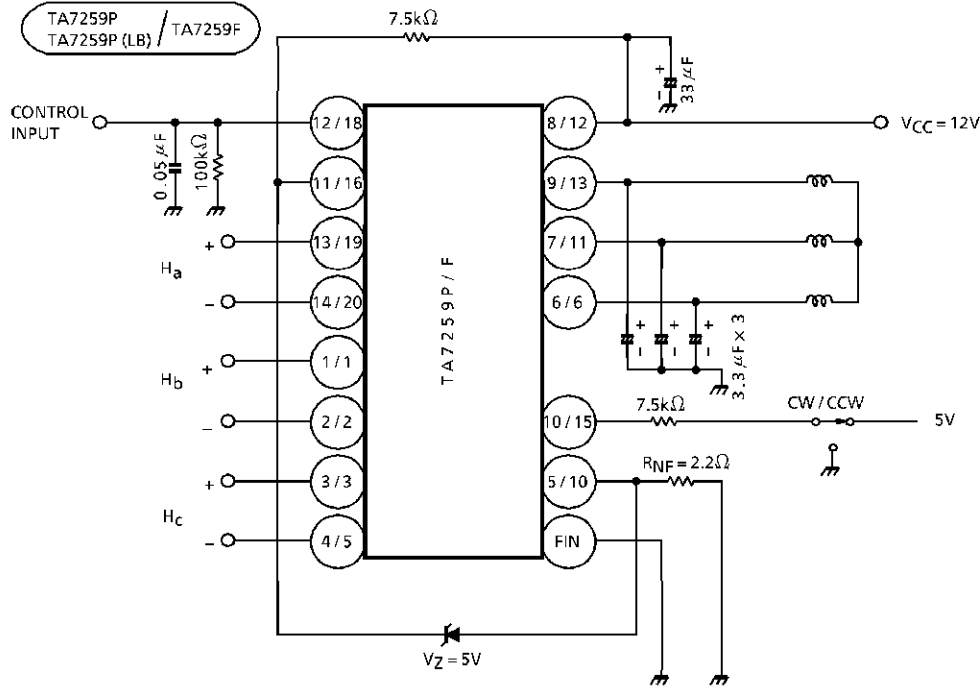

(Note) Utmost care is necessary in the design of the output line, V_{CC} and GND line since IC may be destroyed due to short-circuit between outputs, air contamination fault, or fault by improper grounding.

OUTLINE DRAWING
HDIP14-P-500-2.54A

Unit : mm

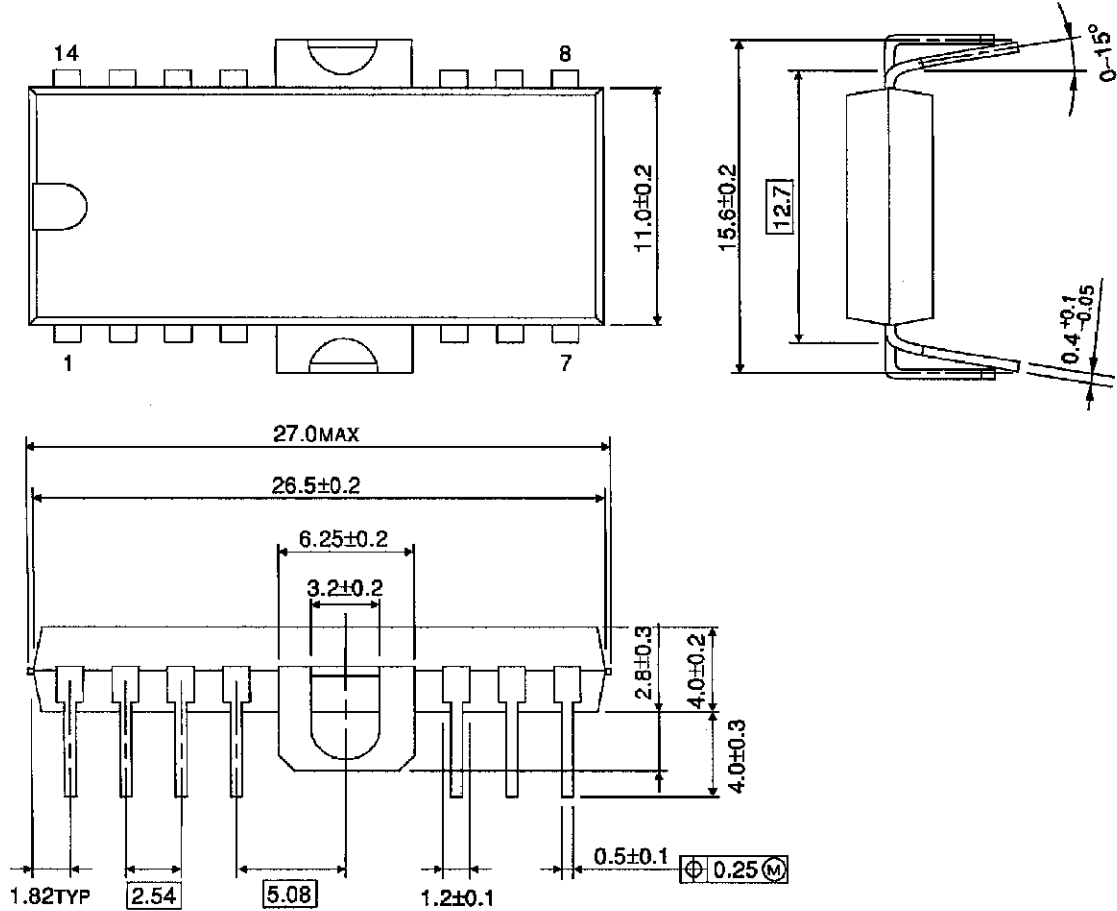

Weight : 3.00g (Typ.)

OUTLINE DRAWING
HSOP20-P-450-1.00

Unit : mm

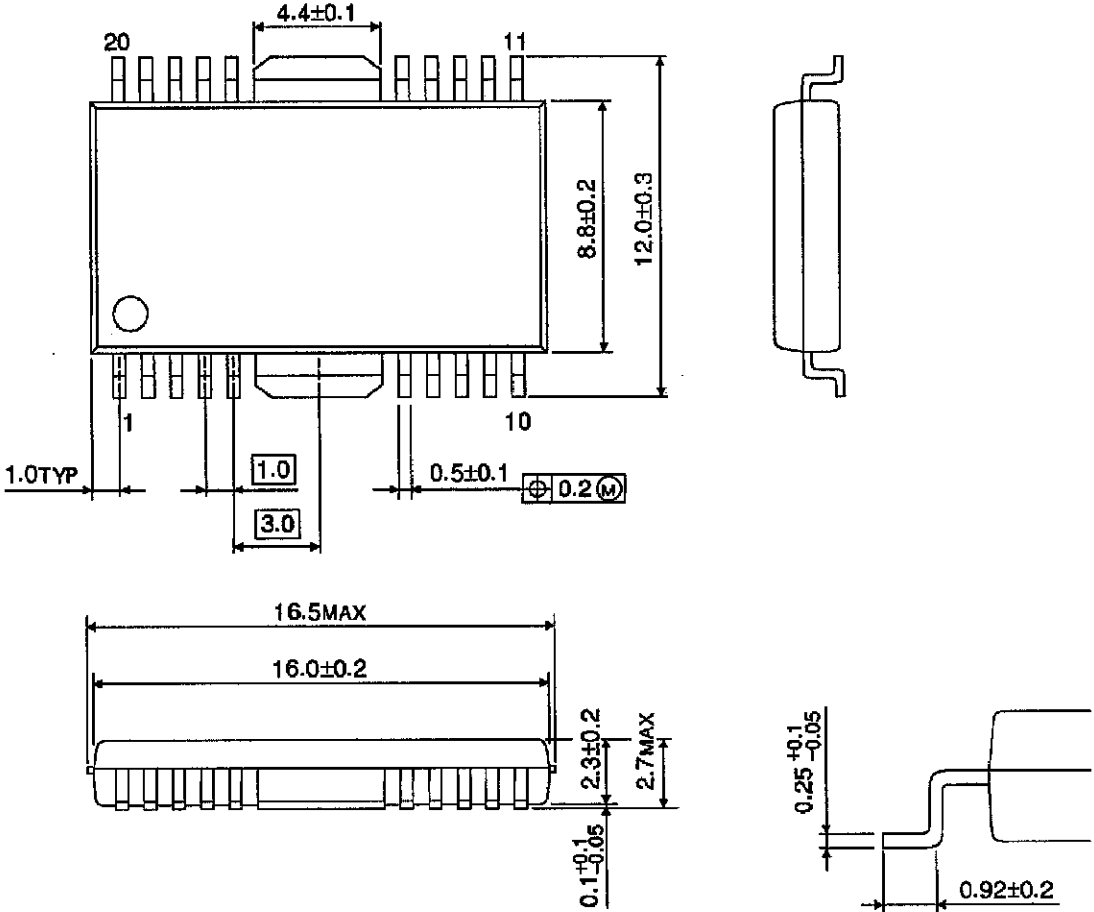

Weight : 0.79g (Typ.)