

**INTEGRATED CIRCUITS**



# Desktop Video Data Handbook

**Philips Semiconductors**



**PHILIPS**

Cover art by Joe Kelly.

*Moby Dick*, the tale of a deranged whaling captain's obsessive voyage to find and destroy the great white whale that had ripped off his leg, is at once an exciting sea story, a sociological critique of various American class and racial prejudices, a repository of information about whales and whaling, and a philosophical inquiry into the nature of good and evil, of man and his fate. And it is three pages shorter than the Philips Semiconductors 1994 *Desktop Video Data Handbook*.

Although it is now considered among the greatest of all novels, *Moby Dick* was ill-received and poorly understood at the time. Herman Melville, its author, died in poverty and obscurity in 1891.

No endorsement of contemporary whaling practices is intended by the allegorical cover art.

No animals, virtual or otherwise, were injured in the creation of the cover.

# Desktop Video Data Handbook

## CONTENTS

		page
SECTION 1	GENERAL INFORMATION	1-3
SECTION 2	APPLICATION NOTES AND MATERIALS	2-3
SECTION 3	FUNCTIONAL INDEX OF PRODUCTS	3-3
SECTION 4	PACKAGE OUTLINES	4-3
SECTION 5	NORTH AMERICAN SALES OFFICES, REPRESENTATIVES, AND DISTRIBUTORS	5-3
APPENDIX A	DATA HANDBOOK SYSTEM	A-1

## DEFINITIONS

Data Sheet Identification	Product Status	Definition
<i>Objective Specification</i>	Formative or In Design	This data sheet contains the design target or goal specifications for product development. Specifications may change in any manner without notice.
<i>Preliminary Specification</i>	Preproduction Product	This data sheet contains preliminary data, and supplementary data will be published at a later date. Philips Semiconductors reserves the right to make changes at any time without notice in order to improve design and supply the best possible product.
<i>Product Specification</i>	Full Production	This data sheet contains Final Specifications. Philips Semiconductors reserves the right to make changes at any time without notice, in order to improve design and supply the best possible product.

Philips Semiconductors and Philips Electronics North America Corporation reserve the right to make changes, without notice, in the products, including circuits, standard cells, and/or software, described or contained herein in order to improve design and/or performance. Philips Semiconductors assumes no responsibility or liability for the use of any of these products, conveys no license or title under any patent, copyright, or mask work right to these products, and makes no representations or warranties that these products are free from patent, copyright, or mask work right infringement, unless otherwise specified. Applications that are described herein for any of these products are for illustrative purposes only. Philips Semiconductors makes no representation or warranty that such applications will be suitable for the specified use without further testing or modification.

### LIFE SUPPORT APPLICATIONS

Philips Semiconductors and Philips Electronics North America Corporation Products are not designed for use in life support appliances, devices, or systems where malfunction of a Philips Semiconductors and Philips Electronics North America Corporation Product can reasonably be expected to result in a personal injury. Philips Semiconductors and Philips Electronics North America Corporation customers using or selling Philips Semiconductors and Philips Electronics North America Corporation Products for use in such applications do so at their own risk and agree to fully indemnify Philips Semiconductors and Philips Electronics North America Corporation for any damages resulting from such improper use or sale.

Philips Semiconductors and Philips Electronics North America Corporation register eligible circuits under the Semiconductor Chip Protection Act.

© Copyright Philips Electronics North America Corporation, 1994

Our appreciation is extended to the following persons for their assistance in the publication of the Desktop Video Handbook:

To: all the Philips factory representatives who supplied updated data sheets at short notice.  
also to:

Herb Knies	Application notes
Marc Schneider	Application notes
Leo Warmuth	Application notes
Joanne Puma	Layout
Celia Tippit	Compilation and Editing
George Ellis	Compilation, Editing, and Application notes
Steve Solari	Concept
Joe Kelly	Cover Art

All rights reserved.  
Printed in U.S.A.

**Section 1 – General Information**

Digital video now, an introduction .....	1-3
Application configurations .....	1-6
Pro Electron type designation code for integrated circuits .....	1-11
Handling MOS devices .....	1-13
High-performance 8-bit video data converters .....	1-14
Line-locked digital colour decoding .....	1-22
AN ETV/IR89126      Digital interfaces for component video signals .....	1-29
CCIR REC. 601-2      Encoding parameters of digital television for studios .....	1-39
CCIR 656              RECOMMENDATIONS OF THE CCIR, 1990 .....	1-49
Color space, digital coding, and sampling schemes for video signals .....	1-63
Video signal bandwidth/resolution .....	1-67
TV transmission standards; colour systems .....	1-68
International TV systems and standards .....	1-69
Contact addresses .....	1-73
Video glossary .....	1-74
Alphanumeric index of products .....	1-76

**Section 2**

DPC7110              Video capture card (24/16-bit) with display filter .....	2-3
DPC7116SD          Video to PCI demo board .....	2-17
Clock and synchronization signals of SAA7187 and SAA7188: Application note for digital video encoder .....	2-30
DTV7188A            Evaluation board for SAA7188A encoder .....	2-48
DTV9051             Digital video evaluation module .....	2-54
DTV7199 Digital Television Demonstration System .....	2-68
SAA7199B operational modes .....	2-93
DTV7194/96         Desktop video demo board .....	2-103
Crystal specifications .....	2-139
TDA8708 black level and gain modulation circuit .....	2-140
TDA9141 analog decoder application .....	2-143
Digital video evaluation board .....	2-149
CVBS output filter for SAA7199B encoder .....	2-157
SAA1101 sync generator application .....	2-162
The I <sup>2</sup> C-bus and how to use it (including specification) .....	2-163
I <sup>2</sup> C bus addresses .....	2-182
I <sup>2</sup> C parallel printer port adaptor .....	2-183
AN425                Interfacing the PCF8584 I <sup>2</sup> C-bus controller to 80C51 family microcontrollers .....	2-184
What is Teletext? .....	2-204
Packet and Page Teletext data reception using the SAA5250 .....	2-213

## Section 3

### Analog-to-digital conversion

Analog-to-digital converter selection guide	3-3	
TDA8703	8-bit high-speed analog-to-digital converter	3-790
TDA8706	6-bit analog-to-digital converter with multiplexer and clamp	3-803
TDA8707	Triple RGB 6-bit video analog-to-digital interface	3-813
TDA8708A	Video analog input interface	3-825
TDA8708B	Video analog input interface	3-842
TDA8709A	Video analog input interface	3-859
TDA8712; TDF8712	8-bit digital-to-analog converters	3-878
TDA8714	8-bit high-speed analog-to-digital converter	3-893
TDA8716	8-bit high-speed analog-to-digital converter	3-908
TDA8718	8-bit high-speed analog-to-digital converter	3-924
TDA8755	YUV 8-bit video low-power analog-to-digital interface	3-933
TDF8704	8-bit high-speed analog-to-digital converter	3-1033
TDA8758	YC 8-bit low-power analog-to-digital video interface	3-948
TDA8760	10-bit high-speed analog-to-digital converter	3-963

### Auxiliary functions

PCF8574/PCF8574A	Remote 8-bit I/O expander for I <sup>2</sup> C-bus	3-5
PCF8584	I <sup>2</sup> C-bus controller	3-16
SAA1101	Universal sync generator (USG)	3-41
SAA5252	Line twenty-one acquisition and display (LITOD)	3-100
TDA2595	Horizontal combination	3-644
TDA4670	Picture signal improvement (PSI) circuit	3-675
TDA4680	Video processor with automatic cut-off and white level control	3-685
TDA4686	Video processor, with automatic cut-off control	3-701
TDA4820T	Sync separation circuit for video applications	3-717
TDA8444/AT/T	Octuple 6-bit DAC with I <sup>2</sup> C-bus	3-722
TDA8446; TDA8446T	Fast RGB/YC switch for digital decoding	3-731
TDA8540	4 × 4 video switch matrix	3-763

### Analog color decoding

TDA3566A	PAL/NTSC decoder	3-651
TDA4665	Baseband delay line	3-669
TDA8501	PAL/NTSC encoder	3-738
TDA9141	PAL/NTSC/SECAM decoder/sync processor	3-1010

### Color decoding, encoding and clock ICs (digital)

SAA7110	One Chip Frontend 1 (OFC1)	3-120
	SAA7110 programming example	3-184
SAA7151B	Digital multistandard colour decoder with SCART interface (DMSD2-SCART)	3-202
SAA7157	Clock signal generator circuit for digital TV systems (SCGC)	3-252
SAA7183	Digital video encoder (square pixel with Macrovision)	3-302
SAA7187	Digital video encoder (DENC2-SQ)	3-332
SAA7188A	Digital video encoder (DENC2-M)	3-359
	SAA7188A programming example	3-385
SAA7191B	Digital multistandard colour decoder, square pixel (DMSD-SQP)	3-387
SAA7194	Digital video decoder and scaler circuit (DESC) ( <i>short-form data sheet</i> )	3-454
SAA7196	Digital video decoder, scaler, and clock generator (DESCPro)	3-457
SAA7197	Clock signal generator circuit for Desktop Video systems (SCGC)	3-511
SAA7199B	Digital video encoder, GENLOCK-capable	3-517
SAA9051	Digital multistandard TV decoder	3-575
SAA9057B	Clock signal generator circuit for Digital TV systems (CGC)	3-619

## Digital-to-analog conversion

Digital-to-analog converter selection guide	3-4
SAA7165 Video enhancement and D/A processor (VEDA2)	3-276
SAA7169 35 MHz triple 8-bit D/A converter for high-speed video	3-295
SAA9065 Video enhancement and D/A processor (VEDA)	3-626
TDA8702 8-bit video digital-to-analog converter	3-776
TDA8771 Triple 8-bit video digital-to-analog converter	3-984
TDA8772; TDA8772A Triple 8-bit video digital-to-analog converter	3-996

## Digital video processing

SAA7116 Digital video to PCI interface	3-185
SAA7152 Digital video comb filter (DCF)	3-243
SAA7164 Video enhancement and D/A processor (VEDA3)	3-258
SAA7186 Digital video scaler	3-303
SAA7192A Digital colour space converter	3-418

## Teletext

SAA5191 Teletext video processor	3-52
SAA5231 Teletext video processor	3-58
SAA5250 Interface for data acquisition and control (for multi-standard teletext systems)	3-69
SAA5296 Single chip economy 10 page teletext/TV microcontroller	3-114
SAA9042 Multi-standard Teletext IC for standard and features TV	3-549

## Section 4

SOT38-1 Plastic dual in-line package; 16 leads (300 mil)	4-3
SOT96A 8-Pin Plastic SOL (Small Outline Large) Dual In-Line (D/T) Package	4-4
SOT101 24-Pin Plastic Dual In-Line (N/P) Package with Internal Heatspreader	4-5
SOT102 18-Pin Plastic Dual In-Line (N/P) Package with Internal Heatspreader	4-6
SOT109A 16-Pin Plastic SO (Small Outline) Dual In-Line (D/T) Package	4-7
SOT117-1 Plastic dual in-line package; 28 leads (600 mil) with internal heat spreader	4-8
SOT129 40-Pin Plastic Dual In-Line (N/P) Package	4-9
SOT136-1 Plastic small outline package; 28 leads; large body	4-10
SOT137-1 Plastic small outline package; 24 leads; large body	4-11
SOT146EF4 20-Lead Dual In-Line; Plastic	4-12
SOT158A 40-Pin Plastic VSO (Very Small Outline) Dual In-Line (D/T) Package	4-13
SOT162-1 Plastic small outline package; 16 leads; large body	4-14
SOT163AG7 20-Lead Mini-pack; Plastic	4-15
SOT187 44-Pin Plastic Leaded Chip Carrier; Pocket Version (A) Package	4-16
SOT188AA 68-Pin Plastic Leaded Chip Carrier; Pocket Version (A) Package	4-17
SOT189CG 84-Pin Plastic Leaded Chip Carrier (A) Package	4-18
SOT225 160-Pin Plastic Quad Flat Pack (H) Package	4-19
SOT232 32-Pin Plastic Shrink Dual In-Line (N/P) Package	4-21
SOT234AG 24-Lead Plastic Shrink Dual In-Line Package	4-22
SOT247-1 52-Pin Shrink Dual In-Line Package; Plastic	4-23
SOT261-2 Plastic leaded chip carrier, 28 leads	4-24
SOT287-1 Plastic small outline package; 32 leads; large body	4-25
SOT307-2 44-Pin Plastic Quad Flat Pack (B) Package	4-26
SOT313-2 Plastic thin quad flat package; 48 leads; 7 x 7 x 1.4 mm	4-27
SOT317 100-Pin Plastic Quad Flat Pack (B) Package	4-28
SOT318 80-Pin Plastic Quad Flat Pack (B) Package	4-29
SOT340-1 Plastic shrink small outline package; 24 leads; medium body	4-30
SOT349 120-Pin Plastic Quad Flat Pack (B) Package	4-31

## Section 5

Sales Offices, Representatives & Distributors	5-3
Appendix A — Data Handbook System	A-1





# Section 1

## General Information

### CONTENTS

Digital video now, an introduction .....	1-3
Application configurations .....	1-6
Pro Electron type designation code for integrated circuits .....	1-11
Handling MOS devices .....	1-13
High-performance 8-bit video data converters .....	1-14
Line-locked digital colour decoding .....	1-22
AN ETV/IR89126 Digital interfaces for component video signals .....	1-29
CCIR REC. 601-2 Encoding parameters of digital television for studios .....	1-39
CCIR 656 RECOMMENDATIONS OF THE CCIR, 1990 .....	1-49
Color space, digital coding, and sampling schemes for video signals .....	1-63
Video signal bandwidth/resolution .....	1-67
TV transmission standards; colour systems .....	1-68
International TV systems and standards .....	1-69
Contact addresses .....	1-73
Video glossary .....	1-74
Alphanumeric index of products .....	1-76



## Digital video now, an introduction

In the old days, if you wanted to see video, you turned to your television set. Nowadays, video is popping out all over--on PCs, workstations, teleconferencing gear, and a spate of medical and test equipment.

### WHY?

Because humans live in a real-time, natural color world that machines are just catching up with. Video enhances the effectiveness of education, training, medical diagnosis, and just about any attempt to communicate.

### HOW?

People are using digital video processing ICs from Philips Semiconductors-Signetics to facilitate the fusion of video and graphics. Look:

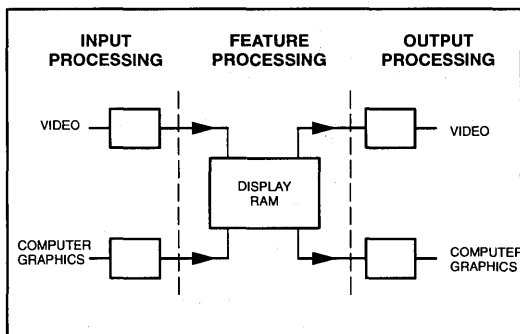

Unfortunately, this simple diagram hides a host of difficulties, including differences in scanning schemes, screen refresh rates, resolution, and color encoding. Fortunately, Philips has been into televisions since Felix was a kitten, and knows how to deliver video that looks good, even under adverse conditions.

### WHAT DO YOU NEED?

The system that you select to decode and digitize your video signal must meet the following requirements:

- Support for Standards
- Orthogonal Sampling Structure
- Ease of Implementation

### SUPPORT FOR STANDARDS

#### PAL, NTSC, SECAM

Philips digital video can detect which of the three international broadcast standards it is receiving and automatically switch to decode it!

#### S-VHS

Industrial applications frequently demand the increased performance of Super-VHS. Philips digital video can process S-VHS with the addition of a second analog-to-digital converter to handle the chrominance channel.

### CCIR601

CCIR601 is an internationally established standard for digitizing PAL, NTSC, and SECAM. This standard is frequently called D1 in the U.S.

We offer a chip set that is 100% compatible with this standard, as well as other chip sets that address different market requirements.

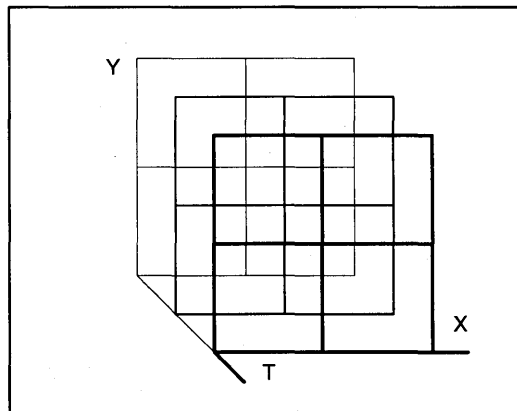

### ORTHOGONAL SAMPLING STRUCTURE

Processing in the horizontal (X), vertical (Y), and time (T) dimensions requires that picture elements are in identical positions in each frame. Philips' unique **line-locked-clock** implementation satisfies this requirement.

Examples of video processing include:

- Filtering in the X-direction: bandpass filter.
- Filtering in the Y-direction: simple comb filter.
- Filtering in the T-direction: noise reduction.

In the Philips digital video system, the sample clock is synchronized with the input's sync signal. An internal discrete time oscillator is used to demodulate the chroma.

This concept combines quartz stability with adaptive handling of video line frequency, and delivers picture elements in each field in identical positions. After all, nobody wants pixels that deviate.

It guarantees robust recovery of the video signal, without jitter, tearing or loss of color, even under the following adverse conditions:

- Time-base errors from
  - VHS or 8mm tape playback
  - Videotape shuttle
  - Videodisc freeze/frame
- Poor signal-to-noise ratio from
  - Low signal strength

# Digital video now, an introduction

## EASE OF IMPLEMENTATION

The Philips digital video system is simple to use:

- No adjustments.
- All 5-volt operation.
- Small form-factor--all parts available in surface mount
- Architecture is partitioned to simplify the addition of features.
- Digital circuitry is constant, reproducible, and not subject to manufacturing variations.
- It is not influenced by variations in supply voltage or aging.
- There are no tolerances and therefore no need for circuit adjustments.
- Digital control is readily implemented via I<sup>2</sup>C\*, without the need for D/As or other interfaces.
- Digital filters are implemented on-chip, and offer linear phase response.
- A single crystal supports different broadcast standards.

## THE BUILDING BLOCKS:

### INPUT PROCESSING

#### Analog to Digital Converter (A/D)

We offer a broad range of high performance A/Ds incorporating Philips' unique folding and interpolation architecture (see glossary). Two of these are specially configured for the digital video chip set: the TDA8708 for composite video (CVBS) inputs, and the TDA8709 for chroma inputs in S-VHS applications.

With the TDA8708, one can select one of three composite video signals to input to the system. This IC includes clamping, automatic gain control, and drive for an external low-pass filter. The signal is then fed to an internal eight-bit analog to digital converter, and finally output to the Digital MultiStandard Decoder.

#### Digital MultiStandard Decoder (DMSD)

The DMSD accepts digitized composite video, performs horizontal and vertical synchronization processing, and outputs Luminance (Y) and Chrominance (U,V) signals. Via I<sup>2</sup>C (see glossary), one can control color hue and luminance frequency response for optimum performance.

Philips offers four DMSDs:

- SAA9051 for consumer applications:  
7-bits; Y:U:V 4:1:1; 13.5 MHz, 720 pixels/line
- SAA7151 for industrial applications:  
8-bits; Y:U:V 4:2:2; 13.5 MHz, 720 pixels/line
- SAA7191 for computer graphics:  
8-bits; Y:U:V 4:2:2; NTSC 12.27 MHz, 640 pixels/line  
PAL/SECAM 14.75 MHz 768 pixels/line
- SAA7194(6) for computer graphics:  
8-bits; Y:U:V 4:2:2; NTSC 12.27 MHz, 640 pixels/line  
PAL/SECAM 14.75 MHz 768 pixels/line

#### Clock Generator Circuit (CGC)

This IC works together with the DMSD to lock to the incoming signal's sync and generate the necessary system clocks. Philips offers three CGCs, one for each DMSD.

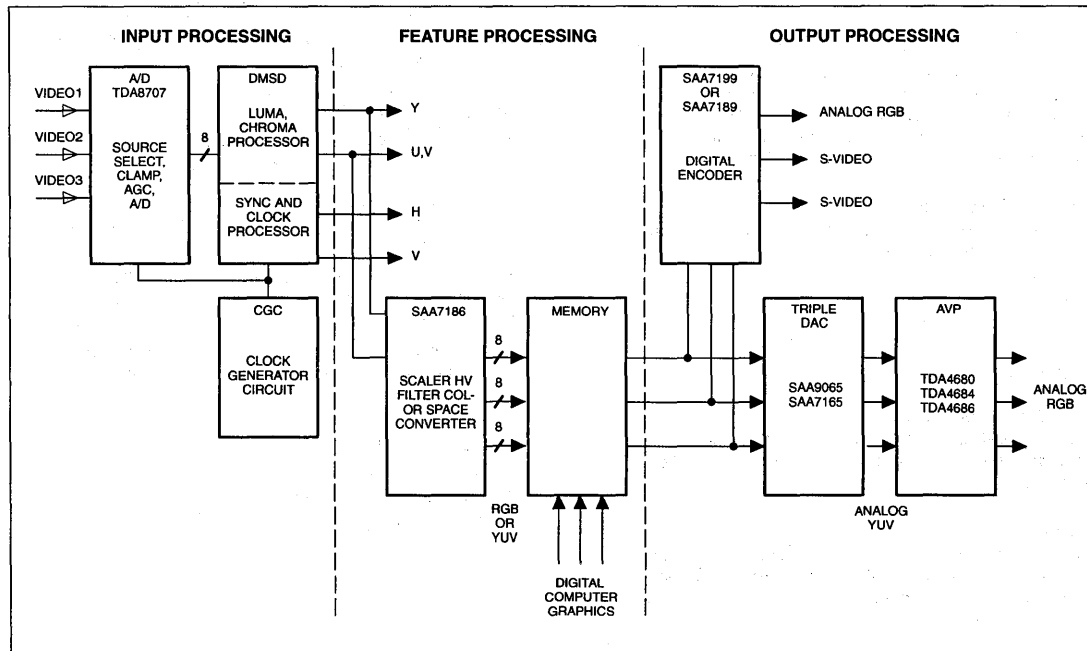

---

## Digital video now, an introduction

---

### FEATURE PROCESSING

Philips digital video architecture allows the data to be manipulated and freely shifted in time between input and output. Examples of processing which could be implemented here include manipulating the size of the picture, filtering, noise reduction, or data compression.

### Digital Color Space Conversion (DCSC)

The SAA7192 digital color space converter connects directly to either the SAA7151 or SAA7191 DMSD. It accepts the Y:U:V data, interpolates samples, digitally converts Y:U:V to R:G:B, and performs inverse gamma correction via an on-chip look-up table. It outputs R:G:B 8:8:8, which can then be manipulated as computer graphics, or directly converted into analog red, green, and blue through a D/A, such as the TDA8702 or SAA7169.

### Digital Video Scaler (DVS)

The SAA7186 digital video scaler connects directly to all Philips 8-bit decoders (SAA7151 B, SAA7191 B, and SAA7194/6) DMSD. It accepts the YUV data, interpolates samples, scales the video downward to any desired size, filters the scaled video in both the horizontal and vertical domains and performs digital color space conversion of the YUV data into several formats of YUV and RGB video. It also contains an output buffer with handshaking for ease of interface and an anti-gamma ROM (bypassable).

### Digital Decoder and Scaler (DESC)

The SAA7194/6 integrates the functionality of the SAA7191 B digital decoder, SAA7197 clock generator (SAA7196 only) and the SAA7186 scaler IC's. Input processing, and feature processing are integrated into one device.

### Digital Encoder (DENC)

The SAA7199B (DENC) is a digital video to analog CVBS or S-Video encoders. This device is multistandard. The 7199B accepts digital RGB, YUV, 8-bit Indexed and digitized composite video as inputs. It also features a digital genlock input to aid in synchronizing the encoding system to other reference sources. The SAA7199 will simultaneously output CVBS (composite) and S-Video into 75 ohm loads.

### Video Enhancement and D/A processor (VEDA and VEDA2)

The SAA9065 (VEDA) and SAA7165 (VEDA2) accept YUV data input, upsamples and interpolates and converts the data to analog YUV signals. Both 7-bit 4:1:1 and 8-bit 4:2:2 data formats are possible. Both devices can perform aperture correction and the SAA7165 will perform color transient improvement. Both devices will run at 30 MHz so that non-interlaced video can be supported.

### Analog Video Processor (AVP)

The TDA4680, 4685 and 4686 include an analog matrix which will convert analog YUV to analog RGB. These devices also accept synchronous external analog RGB signals and switch between these sources at a pixel rate thus allowing overlay capabilities. I<sup>2</sup>C control of brightness, contrast and saturation is possible. All three devices are pin compatible, the TDA4686 has higher throughput bandwidth.

## GLOSSARY

### I<sup>2</sup>C Bus

The Inter-Integrated Circuit (I<sup>2</sup>C) Bus is a two line, multi-master bus developed by Philips to provide cost-effective control of analog and digital functions among ICs.

I<sup>2</sup>C can simplify the manufacturing process by enabling complete calibration and test under computer control. Philips offers a large family of I<sup>2</sup>C-capable integrated circuits, including microcontrollers, microprocessors, and audio, video, and telephony ICs.

### Folding, Interpolating A/Ds

This term describes the unique technology used in Philips' family of high speed analog to digital converters.

Designers are usually forced to choose between the high performance and high power consumption of bipolar flash A/Ds or the low power consumption and low performance of CMOS A/Ds. By folding comparator inputs and interpolating the outputs, Philips is able to realize an A/D with one quarter the circuitry of a conventional flash converter. That means high performance A/Ds with power consumption as low as 250 mW. In addition to video, these parts are enabling new test and medical imaging applications.

Application configurations

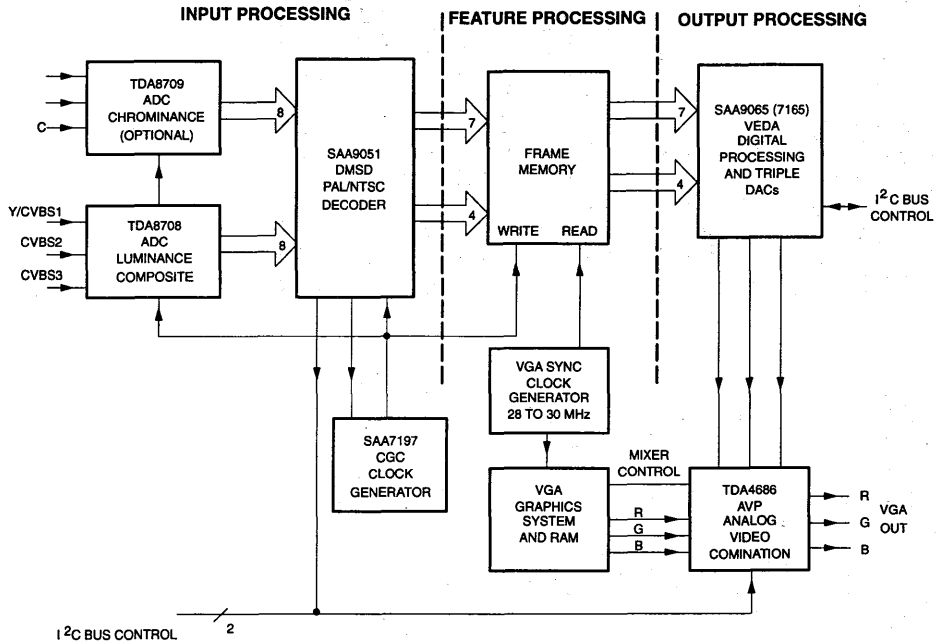

Figure 1. 7-Bit Low Cost Video Frame Grabber with VGA Out

Application configurations

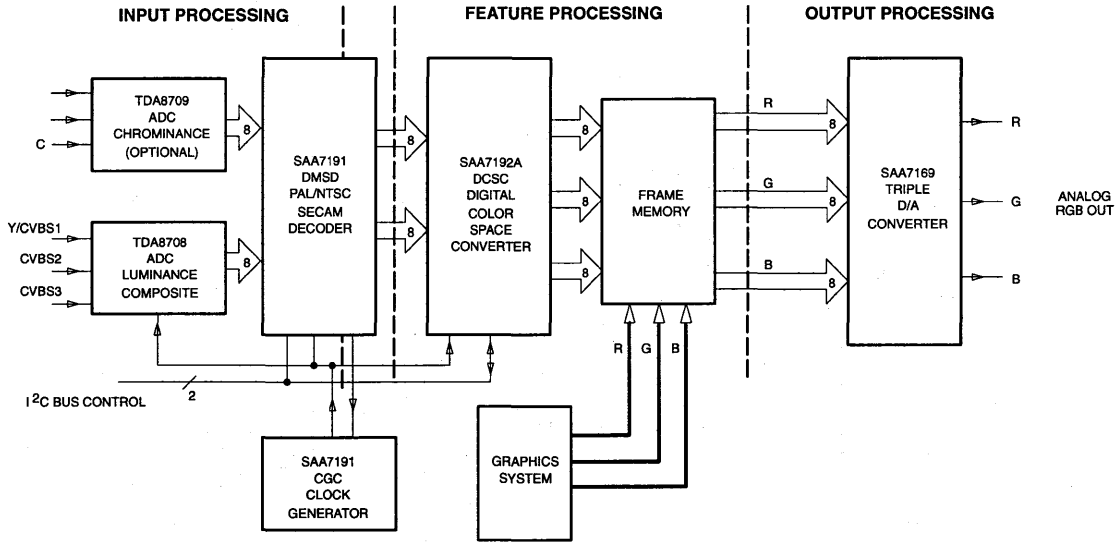

Figure 2. 8-Bit RGB Frame Buffer with Analog RGB Output

Application configurations

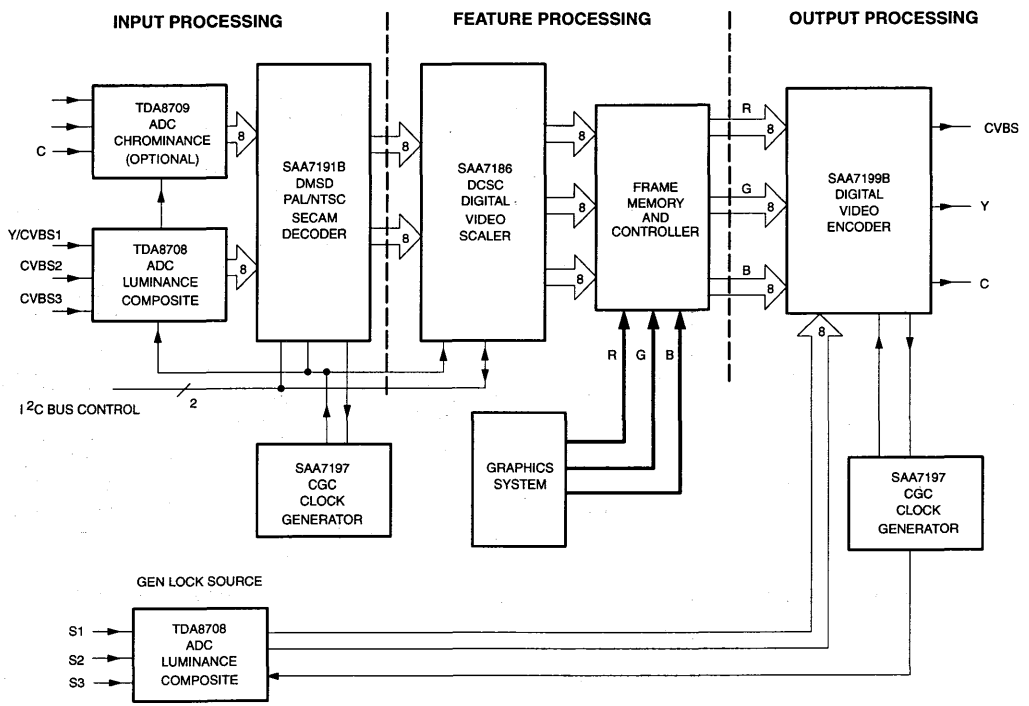

Figure 3. 8-Bit Video Window Graphics with Encoder Gen-Locked to an External Source



Application configurations

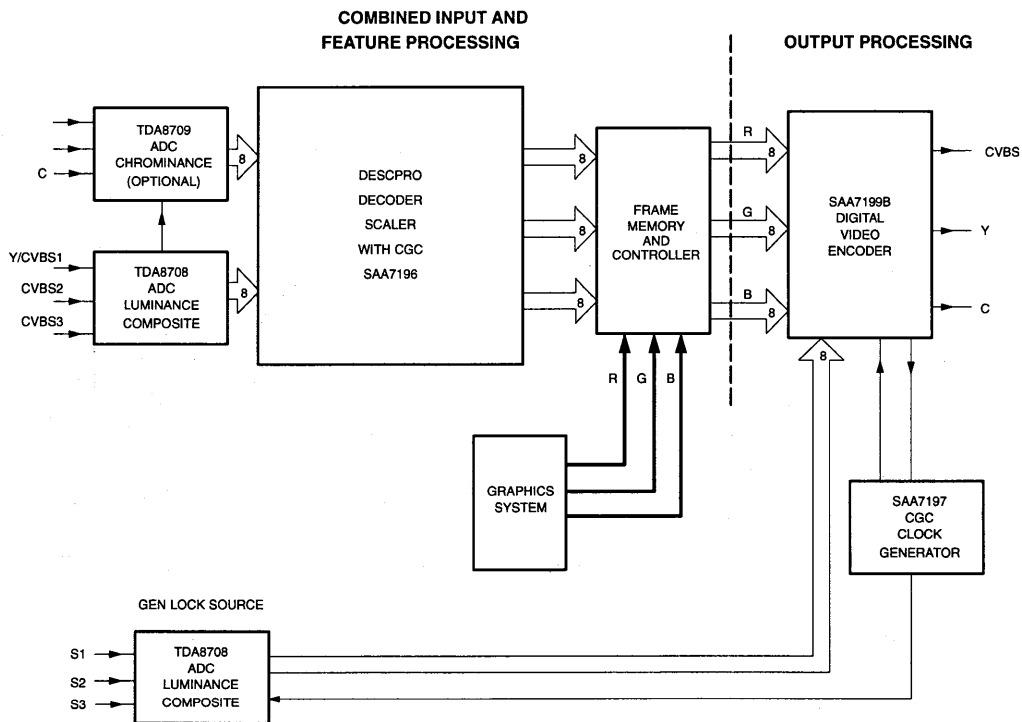

Figure 4. 8-Bit Video Window Graphics with Encoder Gen-Locked to an External Source Using SAA7196 Desco

Application configurations

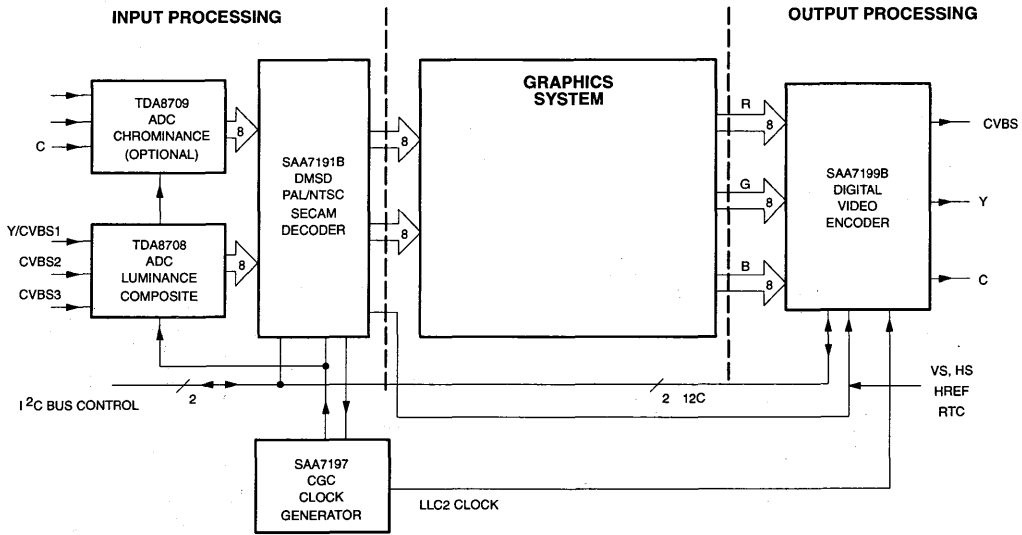

Figure 5. RTC Genlock Mode (Uses Single CGC)

## Pro Electron type designation code for integrated circuits

### Basic type number

This type designation applies to semiconductor monolithic, semiconductor multi-chip, thin film, thick-film and hybrid integrated circuits.

A basic type number consists of three letters followed by a serial number.

### FIRST AND SECOND LETTER

#### Digital family circuits

The first two letters identify the family (see note 1).

#### Solitary circuits

The first letter divides the solitary circuits into:

- S** : solitary digital circuits
- T** ; analog circuits
- U** : mixed analog/digital circuits

The second letter is a serial letter without any further significance except 'H' which stands for hybrid circuits (see note 2).

#### Microprocessors

The first two letters identify microprocessors and correlated circuits as follows:

- MA** : microcomputer central processing unit
- MB** : slice processor (see note 3)
- MD** : correlated memories
- ME** : other correlated circuits (interface, clock, peripheral controller, etc.)

#### Charge-transfer devices and switched capacitors

The first two letters identify the following:

- NH** : hybrid circuits
- NL** : logic circuits
- NM** : memories
- NS** : analog signal processing, using switched capacitors
- NT** : analog signal processing, using charge-transfer device
- NX** ; imaging devices
- NY** : other correlated circuits

### THIRD LETTER

The third letter indicates the operating ambient temperature range. The letters A to G give information about the temperature:

- A** : temperature range not specified below (see note 4)
- B** : 0 to +70°C
- C** : -55 to +125°C
- D** : -25 to +70°C
- E** : -25 to +85°C
- F** : -40 to +85°C
- G** : -55 to +85°C

If a circuit is published for another temperature range, the letter indicating a narrower temperature range may be used or the letter 'A'.

Example: The range 0 to 75°C can be indicated by 'B' or 'A'.

### SERIAL NUMBER

This may be either a 4-digit number assigned by Pro Electron, or the serial number (which may be a combination of figures and letters) of an existing company type designation of the manufacturer.

To the basic type number may be added:

#### Version letter(s)

A single version letter may be added to the basic type number. This indicates a minor variant of the basic type or the package. Except for 'Z', which means customized wiring, the letter has no fixed meaning. The following letters are recommended for package variants:

- C** : for cylindrical
- D** : for ceramic DIL
- F** : for flat pack (2 leads)
- G** : for flat pack (4 leads)
- H** : for quadrature flat pack (QFP)
- L** : for chip on tape (foil)
- P** : for plastic DIL
- Q** : for QIL
- T** : for miniature plastic (mini-pack)
- U** : for uncased chip

## Pro Electron type designation code for integrated circuits

Alternatively a TWO LETTER SUFFIX may be used instead of a single package version letter, if the manufacturer (sponsor) wishes to give more information.

### FIRST LETTER: General shape

<b>C</b>	: cylindrical
<b>D</b>	: dual-in-line (DIL)
<b>E</b>	: power DIL (with external heatsink)
<b>F</b>	: flat (leads on 2 sides)
<b>G</b>	: flat (leads on 4 sides)
<b>H</b>	: quadrature flat pack (QFP)
<b>K</b>	: diamond (TO-3 family)
<b>M</b>	: multiple-in-line (except dual-, triple-, quadruple-in-line)
<b>Q</b>	: quadruple-in-line (QIL)
<b>R</b>	: power QIL (with external heatsink)
<b>S</b>	: single-in-line
<b>T</b>	: triple-in-line
<b>W</b>	: lead chip-carrier (LCC)
<b>X</b>	: leadless chip-carrier (LLCC)
<b>Y</b>	: pin grid array (PGA)

### SECOND LETTER: Material

<b>C</b>	: metal-ceramic
<b>G</b>	: glass-ceramic (cerdip)
<b>M</b>	: metal
<b>P</b>	: plastic

To avoid confusion when the serial number ends with a letter, a hyphen is used preceding the suffix.

### Examples (see note 5)

PCF1105WP	: Digital IC, PC family, operational temperature range -40 to +85°C, serial number 1105, plastic leaded chip-carrier.
GMB74LS00A-DC	: Digital IC, GM family, operational temperature range 0 to +70°C, company number 74LSS00A, ceramic DIL package.
TDA1000P	: Analog circuit, no standard temperature range, serial number 1000, plastic DIL package.
SAC2000	: Solitary digital circuit, operational temperature range -55 to +125°C.

### Notes

1. A logic family is an assembly of digital circuits designed to be interconnected and defined by its basic electrical characteristics (such as: supply voltage, power consumption, propagation delay, noise immunity).
2. The first letter 'S' should be used for all solitary memories, to which, in the event of hybrids, the second letter 'H' should be added (e.g., SH for Bubble-memories).
3. By 'slice processor; is meant: a functional slice of microprocessor.
4. In the case of two same types with two different temperature ranges not specified below, one type should use the letter 'A' as the third letter and the other, the letter 'X'.
5. Some companies have been using version letters and/or two letter-suffix, which differ from the Pro Electron definitions. In case of confusion Pro Electron may be contacted.

## Handling MOS devices

---

### **HANDLING MOS DEVICES**

Though all our MOS integrated circuits incorporate protection against electrostatic discharges, they can nevertheless be damaged by accidental over-voltages. In storing and handling them, the following precautions are recommended.

#### *Caution*

Testing or handling and mounting call for special attention to personal safety. Personnel handling MOS devices should normally be connected to ground via a resistor.

#### **Storage and transport**

Store and transport the circuits in their original packing. Alternatively, use may be made of a conductive material or special IC carrier that either short-circuits all leads or insulates them from external contact.

#### **Testing or handling**

Work on a conductive surface (e.g., metal table top) when testing the circuits or transferring them from one carrier to another. Electrically connect the person doing the testing or handling to the conductive surface, for example by a metal bracelet and a conductive cord or chain. Connect all testing and handling equipment to the same surface.

Signals should not be applied to the inputs while the device power supply is off. All unused input leads should be connected to either the supply voltage or ground.

#### **Mounting**

Mount MOS integrated circuits on printed circuit boards *after* all other components have been

mounted. Take care that the circuits themselves, metal parts of the board, mounting tools, and the person doing the mounting are kept at the same electric (ground) potential. If it is impossible to ground the printed-circuit board, the person mounting the circuits should touch the board before bringing MOS circuits into contact with it.

#### **Soldering**

Soldering iron tips, including those of low-voltage irons, or soldering baths should also be kept at the same potential as the MOS circuits and the board.

#### **Static charges**

Dress personnel in clothing of non-electrostatic material (no wool, silk or synthetic fibers). After the MOS circuits have been mounted on the board, proper handling precautions should still be observed. Until the sub-assemblies are inserted into a complete system in which the proper voltages are supplied, the board is no more than an extension of the leads of the devices mounted on the board. To prevent static charges from being transmitted through the board wiring to the device, it is recommended that conductive clips or conductive tape be put on the circuit board terminals.

#### **Transient voltages**

To prevent permanent damage due to transient voltages, do not insert or remove MOS devices, or printed-circuit boards with MOS devices, from test sockets or systems with power on.

#### **Voltage surges**

Beware of voltage surges due to switching electrical equipment on or off, relays and DC lines.

## High-performance 8-bit video data converters

Wherever there's a need to display a picture on a video screen, there's an attendant demand to enhance the image. This requires the analog video signals to be converted into digital information before the enhancement techniques can be applied. Unfortunately, although integrated 8-bit full-parallel flash ADCs are available for converting high-frequency video signals, the complex circuitry they contain to achieve the required high level of performance makes them too expensive and power consuming and, paradoxically, even restricts their performance for many applications.

We have overcome this problem by developing our innovative TDA87xx range of 20 MSPS to 50 MSPS, or even 100 MSPS 8-bit data converters and fabricating them in a standard high-volume bipolar process (SUBILO-N). This advanced process offers high speed, high packing density and excellent element matching, all of which are crucial factors for integrating high-performance data converters.

### **INNOVATIVE TECHNIQUE REDUCES COST AND POWER CONSUMPTION**

The secret of the success of our TDA87xx data converters lies in an innovative folding and interpolating technique which reduces the number of on-chip components to such an extent that cost is reduced by up to 90%, and power consumption cut by up to 70%. A unique added benefit is that the impressive reduction of chip area we have achieved allows us to offer TDA87xx data converters not only in DIL packages but also in SO packages for surface mounting.

### **PROFESSIONAL PERFORMANCE AT A CONSUMER PRICE**

Despite the remarkable reductions of power consumption and price we have achieved for our TDA87xx range, there is no sacrifice of

performance. For example, our 75 MSPS 8-bit flash ADC type TDA8714 consumes as little as 325 mW, has a minimum differential linearity error of only 1/2 LSB, and a signal-to-noise ratio of 70 dB resulting in a resolution of 7.6 effective bits with an input frequency of 4.43 MHz (75 MHz clock). This compares well with the 6 effective-bit resolution offered by expensive bipolar professional ADCs and far outstrips the 3 or 4 effective-bit resolution obtainable with MOS ADCs for consumer video applications.

The outstanding video frequency performance of our TDA87xx converters, combined with their low cost and power dissipation, makes them ideal for reducing costs without degrading performance in professional and military applications and, for the first time, brings affordable high-performance data conversion to a host of consumer video applications.

## High-performance 8-bit video data converters

### A TO D CONVERSION TECHNIQUES

#### Full-parallel conversion is complex and power-hungry

Most currently available high-performance 8-bit ADCs use the full-parallel implementation shown in a simplified form in Figure 1. In this configuration, 255 comparators simultaneously compare the level of the applied analog input signal with 255 different reference levels derived from a resistor ladder. On the occurrence of each sampling clock pulse, 255 latches store the output states of the 255 comparators and a 255 to 8-line encoder converts the latch outputs into an 8-bit code. Obviously, this full-parallel system is inefficient because much of the information stored in the latches is redundant. For example, since each sample of a full-scale input voltage ramp falls

within the transition range of only one of the comparators, only one of the latches has to change its output state for each sample. Moreover, the 255 latches at the analog to digital interface cause kick-back noise which disturbs the sensitive analog circuitry. The complex circuitry and immense number of signal interconnections occupy a very large area of silicon, restrict operating speed and dissipate considerable power. Also, the analog signal sampling process and attendant aliasing effects impose stringent demands on the distortion and noise behavior of the analog circuitry.

#### Folding and interpolating reduces on-chip components and power consumption

An elegant method of reducing the complexity of the full-parallel ADC circuitry, is

to reduce the number of latches and simplify the encoding logic by combining the outputs from several of the comparators and feeding the resultant signal to a single latch. This "folding" technique is practical as long as the comparators which have their outputs combined are sufficiently far apart on the reference resistor ladder to ensure that any input sample falls within the transition range of only one of them.

The next logical step is to reduce the number of comparators and combining circuits (folding amplifiers), thereby also simplifying the precision reference resistor ladder. This is done by eliminating groups of intermediate comparators fed by consecutive taps on the reference resistor ladder and using a resistor ladder at the remaining comparator outputs to interpolate the missing signals.

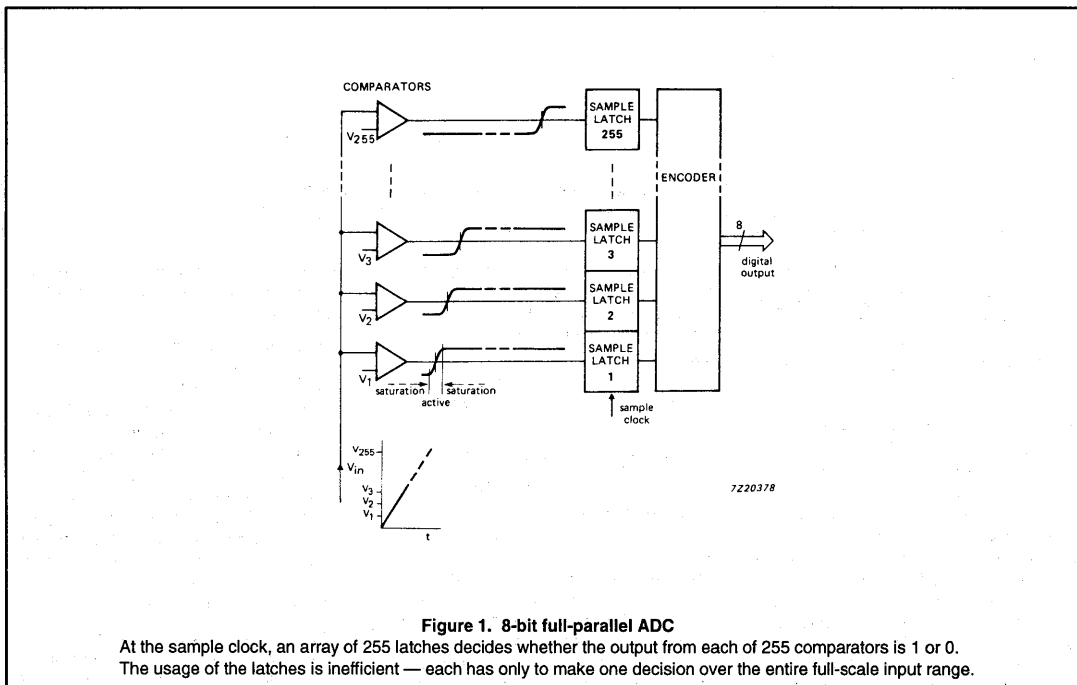
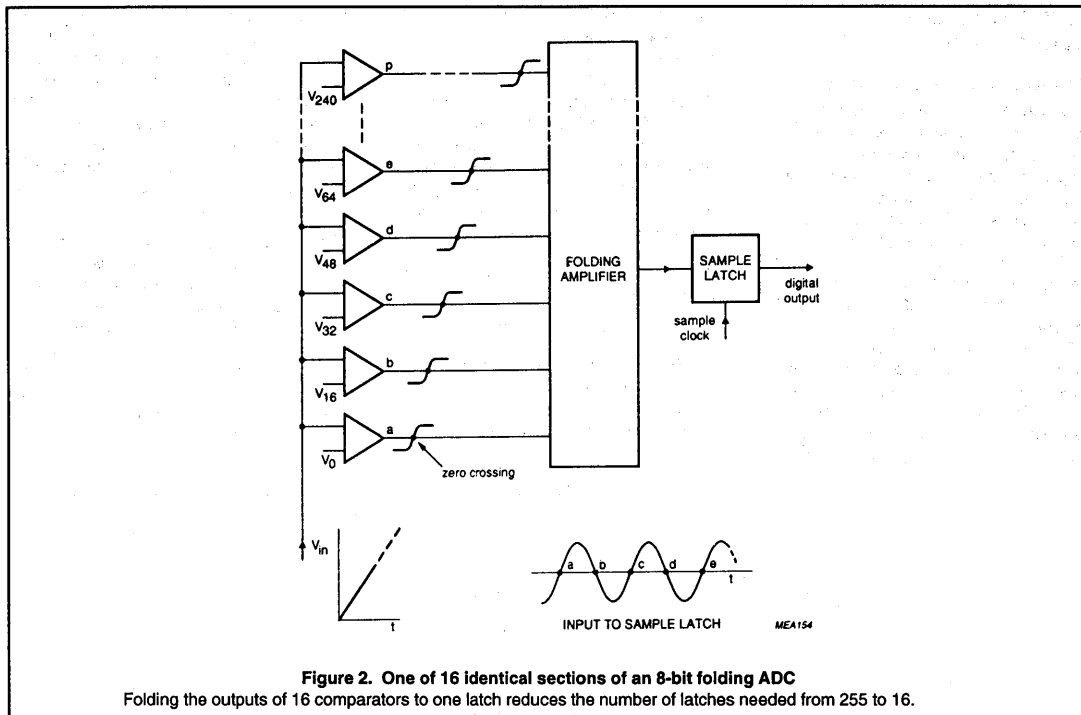

Figure 1. 8-bit full-parallel ADC

At the sample clock, an array of 255 latches decides whether the output from each of 255 comparators is 1 or 0. The usage of the latches is inefficient — each has only to make one decision over the entire full-scale input range.

## High-performance 8-bit video data converters



### Reducing the number of latches by folding the analog input signal

Figure 2 shows one of the sixteen identical sections of a "folding" 8-bit ADC with waveforms for sampling a full-scale input voltage ramp. Here, the outputs from every 16th comparator along the reference resistor ladder are alternately "folded" up and down by sixteen 16-input analog gating circuits (folding amplifiers), the output from each of which is sampled by a single latch. The number of latches required for a complete 8-bit ADC is thus reduced from 255 to 16, and the 255 to 8-line encoder is simplified to a 16 to 8-line circuit. Because the signal distribution problems and chip area for this ADC configuration are also considerably reduced, its overall performance actually improves. Furthermore, since it has only 16 connections between the analog and digital circuitry instead of 255, kick-back noise is much reduced.

Because the output code generated by the 16 latches after folding (fine conversion) is repeated eight times during a full-scale input

voltage ramp, a simple, easy to implement 3-bit coarse converter is needed to determine which of the eight output code cycles is the current one. It is also necessary to equalize the delays introduced by the coarse and fine conversion to ensure that the accuracy of the final data stream is equal to that of the fine converter.

### Reducing the number of comparators by interpolating their outputs

The folding technique was used to reduce the number of latches required for an 8-bit ADC and simplify the encoding logic, thereby reducing chip area, power consumption and signal distribution paths without compromising performance. We will now show how an interpolation technique is used to further this aim by reducing the number of comparators and consequently the number of taps on the precision reference resistor ladder and the number of folding amplifiers. This interpolation technique exploits the fact that a comparator output signal doesn't change state instantly when the input

exceeds the reference level, but follows the input signal linearly over the first part of the transition range.

Figure 3 shows outputs  $V_0$  and  $V_4$  from two of the comparators of the 8-bit folding ADC which are separated by three taps on the reference resistor ladder. It is clear that, since the transition ranges of these two comparators overlap considerably, the three intermediate outputs ( $V_1$ ,  $V_2$  and  $V_3$ ) can be derived by interpolation using a simple 3-tap resistor ladder connected between output  $V_0$  and  $V_4$  as shown in Figure 4. The distortion introduced by the interpolation is unimportant because only the zero crossings are of interest for setting the sampling latch.

By using this interpolation technique, three out of every four comparators are eliminated, thereby reducing the number required for an 8-bit folding and interpolating ADC from 255 to 64. The interpolation technique also reduces the number of taps required on the precision reference resistor ladder from 255 to 64 and reduces the number of folding amplifiers required from 16 to 4.



# High-performance 8-bit video data converters

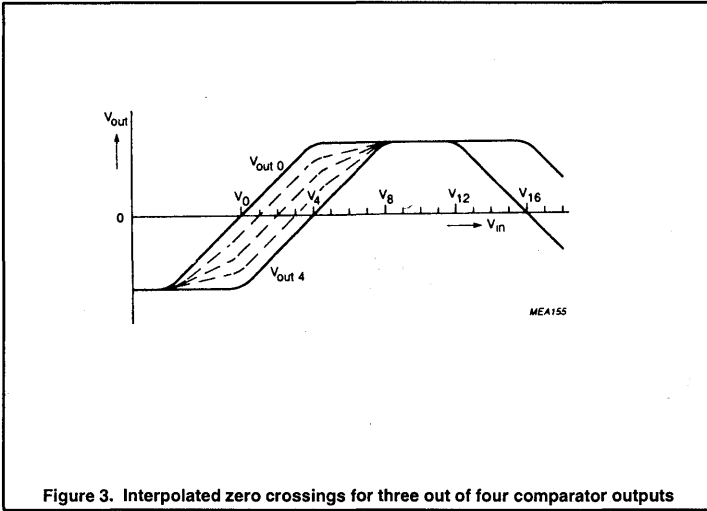

Figure 3. Interpolated zero crossings for three out of four comparator outputs

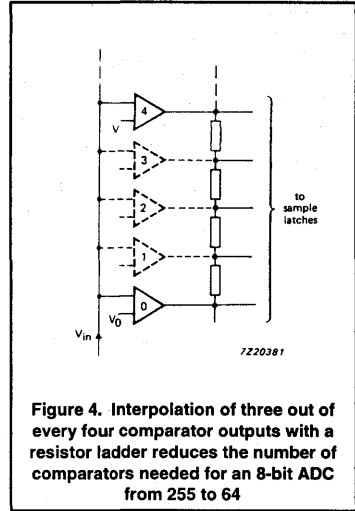
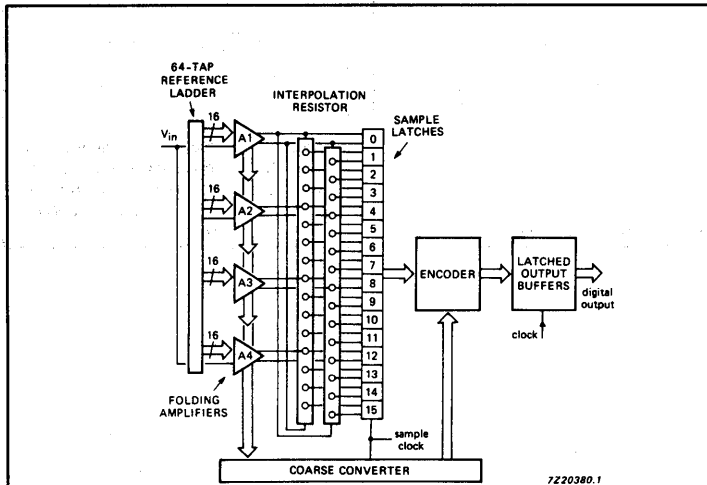

Figure 4. Interpolation of three out of every four comparator outputs with a resistor ladder reduces the number of comparators needed for an 8-bit ADC from 255 to 64

# High-performance 8-bit video data converters

## The complete 8-bit folding and interpolating ADC

Figure 5 is a simplified block diagram of a complete 8-bit folding and interpolating ADC. In this diagram, each of the folding amplifier blocks contains 16 comparators and a folding amplifier. Also, although the interpolation is performed by resistor ladders at the outputs of the folding amplifiers, the principle remains the same as that described for interpolating at the comparator outputs.



**Figure 5. Block diagram of a complete folding and interpolating ADC**

Although, in practice, interpolation takes place after folding of the comparator output signals instead of before as explained for clarity in the main text, the result is the same. The folding amplifier blocks each contain 16 comparators and a folding amplifier.

## Number of internal components for 8-bit full-parallel ADCs compared with those required for folding and interpolating ADCs

	Conventional Full-Parallel ADC	Folding and Interpolating ADC
Reference resistor taps	255	64
Comparators	255	64
Interpolation resistor taps	0	24
Latches	255	16
Encoder stages	255	16
Simple 3-bit coarse converter	0	1
Clock driver fan-out	255	24
Output buffers	8	8

## High-performance 8-bit video data converters

### APPLICATIONS FOR VIDEO ADCs

The high performance combined with the low cost and power consumption of our TDA87xx range of video data converters make them suitable for applications ranging from costly professional equipment requiring the highest performance, to consumer equipment where cost is the major factor.

To quote just a few examples, transportable medical equipment, such as ultrasonic scanners, demands high performance combined with low power consumption. High performance is also essential for converters in sensitive high-frequency test and measuring equipment such as oscilloscopes and spectrum analyzers. The rapidly expanding market for desktop video is another application area. In the consumer world of home entertainment systems, TV set manufacturers and broadcast authorities are meeting the demand for more TV channels and enhancement of picture quality by using digital signal processing techniques. For example, low-cost converters are needed for decoding MAC-encoded multi-channel TV and sound information from broadcast satellites, and for use in the new TV sets with memory-based features that are appearing on the market.

### HOW WE MEASURE THE PERFORMANCE OF OUR ADCs

For an ADC specification to be useful to an equipment manufacturer, it must fully characterize the dynamic performance of the IC. Figures relating to integral and differential linearity at low frequencies are of little use as figures of merit because they have to be laboriously converted into more useful figures for many applications. Output signal-to-noise ratio (SNR), provided it is related to input frequency, is a much better and more versatile figure of merit for an ADC because the "noise" includes both the quantization error and the harmonic distortion. Moreover, a simple formula can be used to convert SNR into "effective bits". However, the SNR of an ADC is not easy to measure, and additional specific data relating to Total Harmonic Distortion (THD) is often required as well. This is why we have developed a special Measurement Bench for accurate determination of the static and dynamic performance of our present and future ADCs.

### ADC measurement bench

Our ADC measurement bench is arranged as shown in Figure 6. It is for use in a laboratory to determine the static and dynamic characteristics of present and future ADCs with up to 12 digital outputs and conversion rates up to 100 MSPS. The following characteristics can be measured:

- signal-to-noise ratio (SNR)
- total harmonic distortion (THD)
- differential non-linearity (DNL)
- integral non-linearity (INL)
- data timing.

- total harmonic distortion (THD)
- differential non-linearity (DNL)
- integral non-linearity (INL)
- data timing.

A PC is used to control the measurement bench and to acquire the sampled input signal to test the ADC. The acquired signal is converted into a data file that is used by a test program developed with scientific Fortran-language software called ASYST, to create histograms, graphs, and a Fast Fourier Transformation (FFT) which facilitate analysis of the ADC output data to determine its operating characteristics.

### Analog input signal

For accurate and complete determination of ADC characteristics, it is necessary to test all of the possible quantization levels. It is also necessary to meet the requirements of the Nyquist sampling theorem that states that it is only possible to fully define an analog waveform digitally if the sampling interval is not more than half the bandwidth of the analog signal.

Although it is possible to use an analog input signal with a triangular or sawtooth (ramp) waveform (theoretically infinite bandwidth), we use a full-scale sinusoidal signal because it has only one frequency component and is comparatively easy to synthesize at high frequencies.

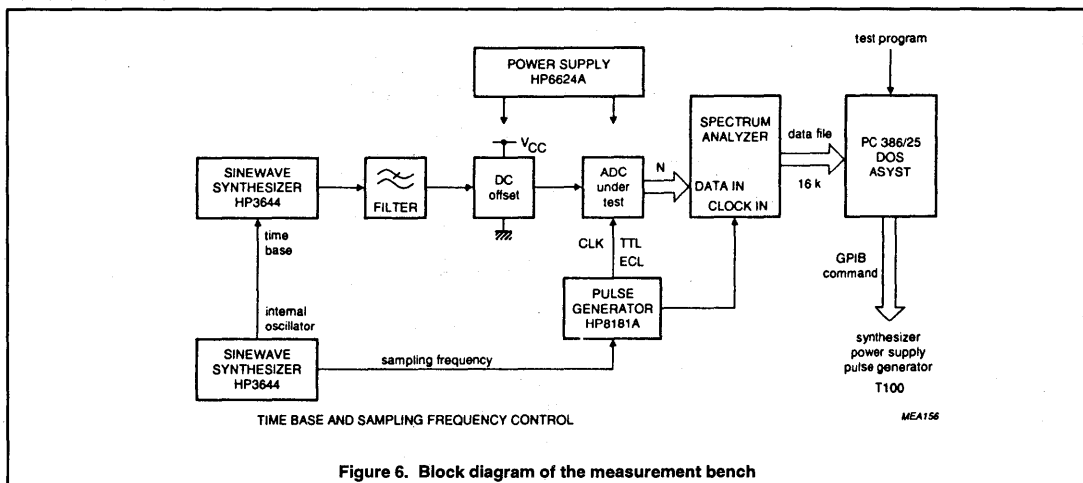

Figure 6. Block diagram of the measurement bench

# High-performance 8-bit video data converters

## Sampling method

At the start of a sinewave period, the slope of the signal is maximum and equal to  $A2\pi f_{in} v/s$ , where A is the peak amplitude. The amplitude to be defined by 1 LSB of the ADC is therefore  $2A/2^N$  volts, where N is the number of data outputs from the ADC. To acquire every quantization level by real-time sampling,  $2^N$  samples must be taken during the period of one half cycle (one peak-to-peak sweep) of the input signal which is  $t_{in}/\pi$ . The time available to describe 1 LSB is therefore  $t_{in}/2^N\pi$ , leading to a required conversion rate of  $2^N\pi/t_{in}$ . For an 8-bit ADC with an input frequency of 5MHz, the conversion rate would therefore have to be 4 GSPS, which is far above the maximum conversion rate specified for any of our ADCs.

Instead of using real-time sampling, our measurement bench therefore uses the multi-beat frequency method of sampling illustrated in Figure 7.

Multi-beat frequency sampling uses the principle of "aliasing" to convert the high frequency input sinewave into a lower frequency sinewave from which it is easier to acquire all the quantization levels for analysis.

Instead of acquiring all the samples during the period of half an input cycle by sampling at  $f_s = 2^N\pi/t_{in}$ , the required number of samples ( $N_O$ ) are now acquired over several

cycles of the input signal and used to reconstruct a sinewave which is a lower frequency aliased version of the input signal.

The ADC under test samples the sinewave input at a rate offset by a small amount from an integer multiple of the input frequency. The small frequency offset is chosen so that the ADC output only changes by one LSB at the point of maximum slope of each consecutive cycle of the input sinewave. Since an LSB period at the point of maximum slope of a sinewave is  $t_{in}/2^N\pi$ , the minimum number of samples that must be acquired to fully test all the quantization levels is  $N_O > 2^N\pi$ , in which  $N_O$  must be rounded to an integer. For an 8-bit converter,  $N_O$  must be at least 805.

Under these conditions, the minimum sampling period (time to acquire all samples during one input cycle) is  $t_{Smin} = t_{in}/N_O$  which gives a maximum sampling frequency of  $f_{Smax} = f_{in}N_O$ . This maximum frequency is too high to be practical and must be reduced to  $f_s = f_{Smax}/K_O$  ( $f_s = t_{Smin}K_O$ ), where the difference between  $K_O$  and  $N_O$  are relative primes. To minimize the sample acquisition time, the value of  $K_O$  should, however, be the minimum permitted by the maximum conversion rate specified for the ADC under test.

The measurement bench uses every  $K_O$ th output from the ADC under test to compile a

sampled sinewave acquired data file. The information in the data file, which is effectively a reconstruction of a sinewave, which is a lower frequency aliased version of the input signal, is then analyzed to determine the ADC characteristics.

## Measuring effective bits and harmonic levels

To determine the signal-to-noise ratio (SNR) and harmonic levels of our ADCs on the measurement bench, the data in the acquired sinewave file is transformed into the frequency domain with a fast Fourier transformation (FFT).

The levels of the signal, its harmonics and the noise can now be clearly seen and easily computed. The FFT is analyzed by the computer to determine  $SNR = P_{signal}/P_{noise}$ .

Instead of specifying SNR, it is possible to specify effective bits (b), which are defined as  $b = (SNR - 1.76)/6.02$ , where SNR is the calculated value in dB when a full-scale sinewave is analyzed.

By determining SNR as a function of input frequency, it is easy to determine the N-bit resolution bandwidth of an ADC which is equal to the input frequency at which the effective bits have decreased to  $N-0.5$ . For an 8-bit ADC, this occurs when the SNR is 46.9 dB.

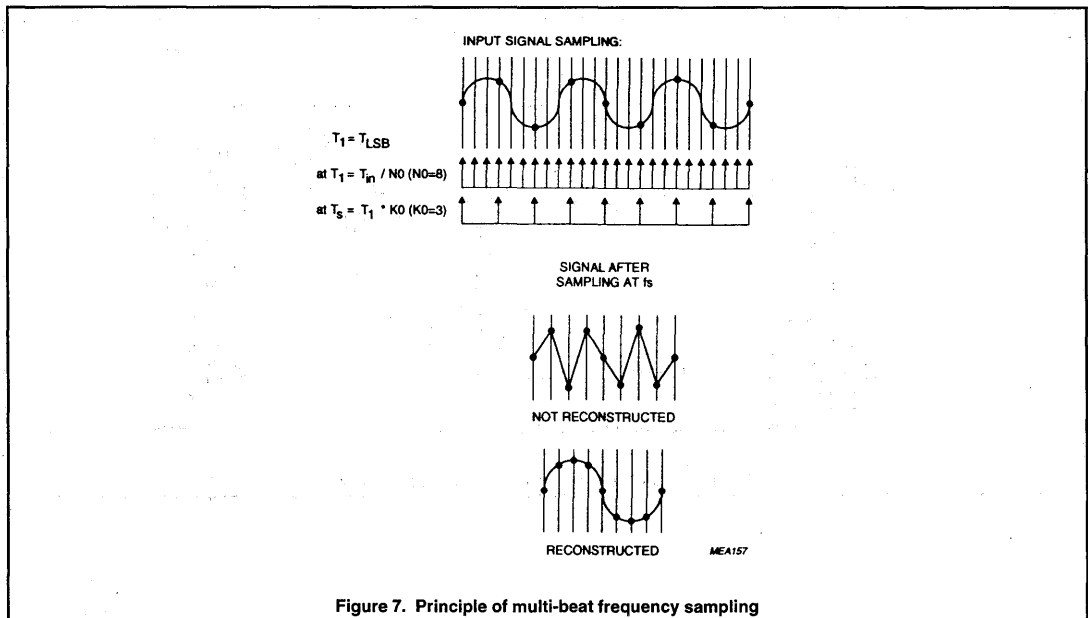

Figure 7. Principle of multi-beat frequency sampling

## High-performance 8-bit video data converters

### **Differential and integral non-linearity**

Differential non-linearity (DNL) is a measure of the maximum amount by which the distance between the midpoints of adjacent steps on the ADC transfer function (quantized output level as a function of input level) differs from the width of one LSB. It is measured with a statistical test in which the acquired sinewave file is used to generate a histogram of the digitized signal with a number  $H(i)$  for each output code  $(i)$ . The probability of obtaining each code is calculated and the ratio of the number of acquired samples of each code  $H(i)$  to the total No of samples ( $N_0$ ) represents the differential non-linearity.

Integral non-linearity (INL) is a measure of the deviation of the ADC transfer function

from the ideal. Since it is equal to the maximum difference between the measured and ideal quantization levels, it can be calculated from the histogram used to calculate DNL. Since  $INL(0) = DNL(0)/2$ , INL can be calculated for each step  $(i)$  of the transfer function as  $INL(i) = INL(i-1) + DNL(i)/2$ . The maximum value thus obtained is the integral non-linearity of the ADC.

### **Data timing**

The relative timing of the output bits of the ADC can be displayed on the screen of the PC that forms part of the measurement bench. Acquisition of the timing data can be either synchronized with the ADC clock pulses the frequencies up to 1 GHz, or asynchronous at frequencies up to 2 GHz.

### **APPLICATION SUPPORT**

When designing data converters into a system, it is essential to pay careful attention to a number of circuit details to ensure that the high performance of our ICs is fully exploited. Correct PCB layout is particularly important, with particular emphasis on track widths, avoidance of ground loops and minimization of crosstalk between the analog and digital circuitry. Care must also be taken to understand the relative timing of the sampled and output data. Other important details include decoupling for noise reduction and stability of internal reference levels, decoupling and harmonic suppression for clock signals, and power supply filtering.

## Line-locked digital colour decoding

Ton Nillesen – CAB-Elcoma, N.V. Philips, Eindhoven (The Netherlands)

On présente dans cet article une méthode de décodage numérique des signaux vidéo couleur basée sur des fréquences d'échantillonnage verrouillées sur la ligne. La fréquence d'échantillonnage est synthétisée à partir de la fréquence d'un cristal. On génère une fréquence stable de sous-porteuse en utilisant la fréquence variable d'échantillonnage par contrôle direct à partir du synthétiseur.

*A digital colour decoding principle involving line-locked sample frequencies is presented. The sampling frequency is synthesized from a crystal frequency. A stable subcarrier frequency is generated from the variable sampling frequency by forward control from the synthesizer.*

To digitally decode PAL or NTSC composite video signals in a TV receiver, it is advantageous for the sampling rate to be related to the colour subcarrier frequency because this simplifies the demodulator and the chroma filters. However after colour decoding, the component video signals for luminance and colour difference are available and the colour subcarrier is then no longer relevant. Line-locked sampling is then a better choice.

In fact, for video processing and conversion to other scanning frequencies, line-locked sampling is a natural choice because it results in orthogonal sampling, which simplifies video signal processing with line and field memories [1].

---

### WHY LINE LOCKED ?

---

Standard conversion to other scanning frequencies might be used for instance for reduction of large area flicker by means of field rate conversion to higher frequencies. Another type of conversion is compression of the signals for features such as picture in picture and multi picture-in-picture, whereas expansion of the signals is required for picture enlargement or C-MAC decoding, etc..

# Line-locked digital colour decoding

Some other examples of signal processing using line or field memories are :

- cross colour and cross luminance reduction with line-, field- or frame-combfilters,
- noise reduction by an integrating temporal filter,
- resolution enhancement by a peaking spatial filter.

Furthermore, a line-locked sample frequency is a must for matrix displays such as LCDs, the index tube and dot matrix printers and it is also a necessity for display of good quality characters. And last but not least, the circuitry for processing line-locked component video signals is substantially independent of transmission standards.

## APPLICATION OF SAMPLE RATE CONVERTER

If a subcarrier-locked colour decoder is used, line-locked samples can be obtained by sample rate conversion. An obvious approach for a Sample Rate

Converter (SRC) is via digital-to-analog (DA) and analog-to-digital (AD) conversion. The subcarrier-locked samples are then converted to analog signals and re-sampled with the line-locked sample frequency (fig. 1a). Although this is a straightforward method, using well-known techniques, it is not attractive because it is expensive. It requires ADCs and DACs, three of each for the three component signals, including the reconstruction filters, and a second clock generator. Furthermore, the additional conversion step degrades signal quality. A second approach is a SRC in the digital domain, the line-locked samples being calculated from surrounding subcarrier-locked samples by means of interpolating algorithms (fig. 1b). Both approaches require two clock generators coupled to the video signal, one burst-locked and the second line-locked.

However, it is not necessary to have the line-locked clock available with equidistant clock transitions. Transfer and processing of the samples with amplitude information belonging to line-locked sampling positions can be done with a gated version of the original clock (fig. 1c). The gated clock should then have a constant number of clock transitions per line period. However a reverse sample rate conversion is then required before DA-conversion. This second SRC is eliminated if the line-locked clock is physically available. DA-conversion is then done with the line-locked clock. However the most complex part of the sample rate conversion is the interpolating algorithm required [2].

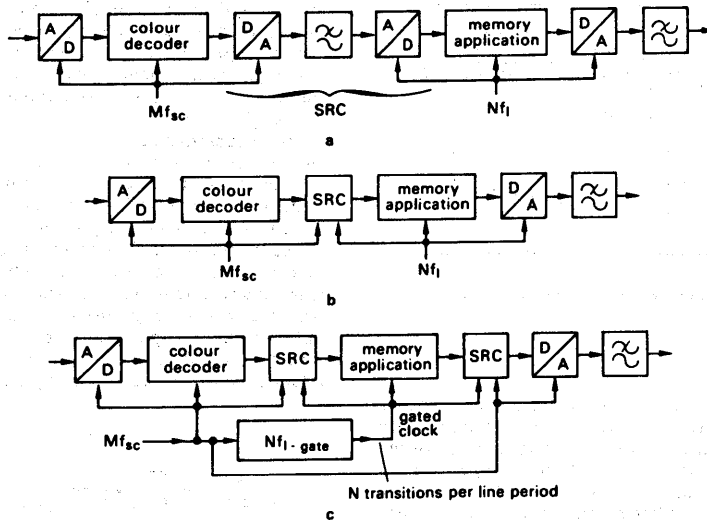

Fig. 1. Application of sample rate converters : a. analog sample rate converter, b. digital sample rate converter and two clocks coupled to video signal, c. two digital sample rate converters and single clock.

# Line-locked digital colour decoding

## INTERPOLATION OF SAMPLES

In principle, interpolation is done by low-pass filtering. The low-pass filter should reject the sidebands of the original subcarrier-locked samples, including at harmonics of the sampling frequency, but should pass the baseband spectrum containing the desired signal with a flat frequency- and linear phase-characteristic. Linear interpolation is certainly not sufficient, neither in the passband nor in the stopband, to preserve good signal quality. Each new sample should therefore be calculated from several surrounding original samples with proper weighting factors. The weighting factors should be of sufficient number and sufficient accuracy to generate new samples with a timing accuracy of about 0.2 ns, if the resulting signal should have a bandwidth of 5 MHz and 8-bit quantization (fig. 2).

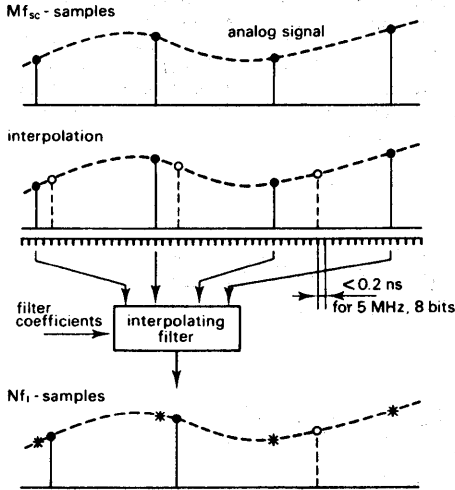

Fig. 2. Principle of sample rate conversion.

For compatibility with non-standard video signals with variable line frequencies, the conversion rate cannot be expressed as a simple ratio of small prime integers but is irrational and time-varying. As a consequence the interpolating filters will be complex with a large set of filter coefficients. A digital SRC will therefore require a relatively large chip area. These are the reasons for considering line-locked colour decoding which produces line-locked samples of the luminance and the colour difference signals directly.

## COLOUR DECODING PRINCIPLE

The NTSC and PAL colour systems use suppressed-carrier amplitude modulation with quadrature subcarriers (fig. 3). The chroma signal can be demodulated by multiplying it by the correctly-phased subcarrier sine and cosine waves. This gives the colour difference signals plus some high frequency components,

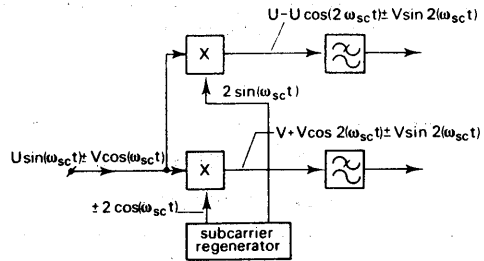

Fig. 3. Colour decoding principle for PAL system.

the latter being removed by filtering. For digital signals, the chroma signal has to be multiplied by the sampled subcarrier waves. If the sample rate is four times the subcarrier frequency, with the correct phase, the multiplications simplify to multiplication by 1, 0, -1 and 0 of successive samples. With line-locked or other sample frequencies asynchronous with the subcarrier, real four-quadrant multipliers are required for demodulation with the asynchronously-sampled subcarrier [3].

In the subcarrier regenerator (fig. 4) the subcarrier phase is coupled to the received colourburst. In order to reduce the effects of noise, the phase information extracted from several bursts is averaged by means of a narrow filter which in general is implemented as a phase locked loop (PLL). In analog circuits, the phase detector normally consists of a multiplier and the loop filter in a second order loop delivers an output signal which is partly proportional to the phase detector output signal and partly an integrated version of that signal. So digitally these blocks can be realised with adders, multipliers and an integrator.

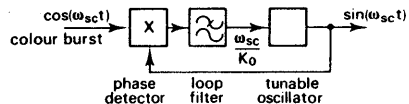

Fig. 4. Schematic diagram of the analog subcarrier regenerator.



# Line-locked digital colour decoding

The tunable oscillator is normally a voltage controlled oscillator with an oscillator control sensitivity of  $K_0$  ( $\text{rd} \cdot \text{s}^{-1} \cdot \text{V}^{-1}$ ). So for an output frequency of  $\omega_c$ , the subcarrier frequency, the loop filter has to deliver a control voltage of  $\omega_c/K_0$ . For sinewave oscillators the instantaneous output is  $\sin(\omega_c t)$ . As a consequence, the oscillator transfers the input signal  $\omega_c/K_0$  to the output signal  $\sin(\omega_c t)$  which, apart from the sine function and the constant  $K_0$ , is an integrating action. The sine function prevents saturation of the output by the ever increasing value of the instantaneous phase. With the sine function the output phase follows the instantaneous phase modulo  $2\pi$  radians.

## THE DISCRETE TIME OSCILLATOR

### (DTO)

The integrating and modulo function of the oscillator can be realised digitally with an accumulator consisting of an adder and D-flip-flops (fig. 5a). The multibit output of the adder is applied to its input via D-flip-flops which are clocked with the clock frequency  $f_{cl}$ . At the second input of the adder, a constant multibit value  $p$  is applied. So at each clock period the pre-

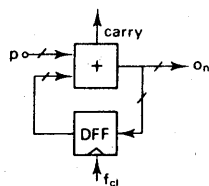

$$O_n = (O_{n-1} + p) \text{ modulo } q$$

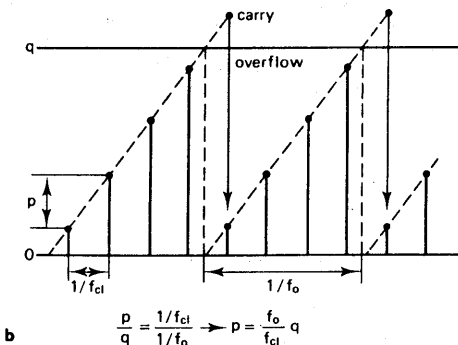

Fig. 5. Principle of the discrete time oscillator.

vious content of the accumulator is incremented by  $p$  until overflow occurs at the value  $q$ . The next value will then be the previous value plus  $p$  modulo  $q$ . So the output resembles a time discrete quantised sawtooth signal whose period is set by  $p$ . Obviously the ratio between  $p$  and  $q$  equals the ratio between the clock period and the period of the output signal  $f_o$ . So the control value  $p$  should be  $f_o/f_{cl} \cdot q$ . If the overflow value is defined as being 1, then the input value simplifies to  $p = f_o/f_{cl}$  (fig. 5b).

That brings us to our definition of a discrete time oscillator (DTO) also known as ratio counter or rate multiplier or accumulator or numerically controlled oscillator. The input value should equal the ratio between the desired output frequency and the clock frequency. Its modulo 1 output indicates from zero to one the instantaneous phase within a single period (fig. 6).

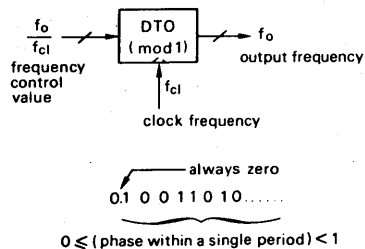

Fig. 6. The discrete time oscillator.

Note that the ratio  $f_o/f_{cl}$  at the input is dimensionless, indicating the phase increment per clock period, whereas the output of the DTO is the instantaneous phase modulo 1, which in principle is varying. Both signals can, in binary notation, be approximated to the required accuracy. However if the clock frequency is not constant whereas a constant subcarrier frequency should be generated, then the frequency control value should be corrected accordingly to the desired accuracy. As a consequence, the line-locked clock should be known with sufficient accuracy and has therefore to be generated with a crystal frequency as reference.

## $N f_i$ GENERATOR

It is a logical step to generate the line-locked sample frequency from a crystal frequency by means of a DTO. The DTO is clocked with the crystal frequency  $f_c$  and the desired output frequency is  $N f_i$ , so the loop

# Line-locked digital colour decoding

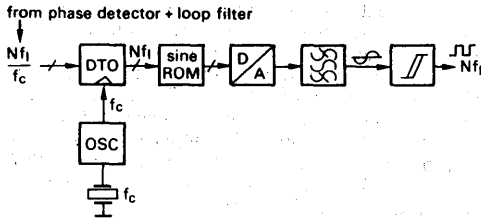

Fig. 7. Generation of line-locked sampling frequency ( $Nf_1$ ) with crystal accuracy.

filter in the horizontal phase locked loop should deliver the numerical value  $Nf_1/f_c$  (fig. 7). The DTO delivers then a quantised sawtooth signal with frequency  $Nf_1$  but in the discrete time domain sampled with the crystal clock  $f_c$ . However the sample frequency should be available as a continuous signal so that it can be used as the system clock. Therefore the DTO output signal is converted from digital to analog after a conversion from sawtooth to sinewave via a sine-ROM. The reconstruction filter delivers then an analog sinewave with no undesired harmonics or mixing products. That sinewave is then converted to the proper logical signal levels.

If this sample frequency generator is used in the horizontal phase locked loop, then the relationship between instantaneous sampling frequency and the crystal controlled reference frequency is known. As a consequence, the generated frequency control value  $Nf_1/f_c$  from the horizontal phase locked loop can be used to correct the DTO in the subcarrier loop for variations in  $Nf_1$ .

## FORWARD CONTROL (DIVIDER)

Figure 8 shows the subcarrier phase locked loop with the burst phase detector, the loop filter, the DTO and the sine plus cosine ROM which delivers the demodulating sine and cosine waves. Between the loop filter

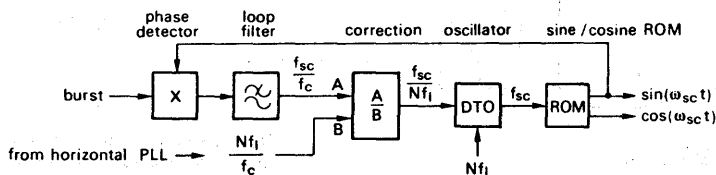

Fig. 8. Forward control of subcarrier DTO operating with line-locked clock.

and the DTO the correction is done for the varying clock frequency.

Since the subcarrier DTO operates with the line-locked clock, a value  $f_{sc}/Nf_1$  should be applied to its input as frequency control value. This value is obtained via an arithmetical divider ( $A/B$ ) which divides the intermediate control value at the output of the subcarrier loop filter by  $Nf_1/f_c$  from the horizontal PLL. The intermediate control value should therefore be  $f_{sc}/f_c$ , the ratio between the subcarrier frequency and the crystal frequency. Apart from long-term variations, this ratio remains constant regardless of the clock frequency. Consequently, the subcarrier loop filter can be designed for narrow noise bandwidth, optimised for subcarrier regeneration. The inaccuracy of the forward control due to the limited wordlength of the signals is handled by the loop as internally-generated noise and can be chosen at a sufficiently low level.

## LINE-LOCKED COLOUR DECODER

A complete block diagram of a line-locked colour decoder is presented in figure 9. For simplicity, several functions such as automatic colour control, colour killer, compensating delays etc. have been omitted in the block diagram. The signal-flow in the horizontal and subcarrier PLLs are indicated in heavy lines as is the correction circuit ( $A/B$ ) which corrects the subcarrier DTO for varying line frequencies. The left-hand part of the circuit operates with the crystal controlled clock frequency  $f_c$  and generates the line-locked sampling frequency  $Nf_1$  with which the rest of the circuit operates. The coupling between these two parts is via the resynchronisation register  $R$  which delivers the control value  $Nf_1/f_c$  to the DTO.

In the synchronisation processing part, the  $Nf_1$  sample frequency is divided down to the line frequency  $f_l$ . The division ratio  $N$  can be made selectable to adapt the sample frequency to the bandwidth of the video signal or to different line frequencies. The counter drives a state decoder which delivers several control



## Line-locked digital colour decoding

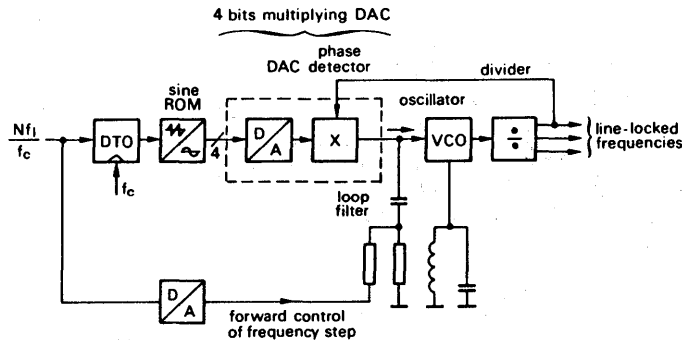

Fig. 10. Analog PLL as reconstruction filter.

Such an implementation is indicated in figure 10. The analog PLL is indicated with a charge pump phase detector, a loop filter, a voltage controlled oscillator (VCO) and the divider which delivers several line-locked frequencies. As a consequence the first part of the circuit can also operate on a subharmonic of the actual sample frequency.

The phase detector is driven by the DA-converter so that these functions can be combined in form of a multiplying DAC. Good results have been obtained with a 4 bit DAC so that this function can be very small in chip area. The required accuracy of the DAC of course is dependent on the quality of the reconstruction filter. A smaller filter bandwidth requires fewer bits for the DAC. However a narrow noise bandwidth of the PLL results in a slower response on frequency steps and consequently larger phase errors. That response can be improved by forward control of the oscillator to the required frequency. That information is available at the input of the  $Nf_c$ -DTO and could be used via DA-conversion for pre-correction of the VCO-frequency.

The factor  $N$ , which determines the sample frequency, can have any appropriate value. An attractive choice is  $N=858$  for 60 Hz TV systems and  $N=864$  for 50 Hz systems. The sampling frequency will then be 13.5 MHz which is in accordance with the CCIR recommendation for digital processing in studio equipment. The number of active samples per line period is then 720 for all TV standards.

---

**CONCLUSION**

---

In this presentation, the principle and the main advantages of line-locked colour decoding have been shown :

- owing to the orthogonal samples, line-locked decoding is optimized for the growing use of picture processing [4, 5] ;
- the system in principle is sample-rate-invariant so that it has excellent multi-standard capabilities and it enables the choice of a common clock for all standards ;
- for applications somewhat further in the future, it is quite important that the principle is directly applicable with matrix displays.

*This article is written as a lecture (for ICCE 85 in Chicago).*

- 1 VAN DE POLDER (L.J.), PARKER (D.W.), ROOS (J.). — Evolution of television receiver from analog to digital. Proc. IEEE, 73, (1985), 599-612.
- 2 RAMSTAD (T.A.). — Digital methods for conversion between arbitrary sampling frequencies. IEEE Trans. Acoust., Speech Signal Process., ASSP-32, (1984), 577-591.
- 3 CLARKE (C.P.K.). — Digital PAL decoding using line-locked sampling. 8th Int. Broadcasting Convention Proc., IEE pub. n° 191, (1980).
- 4 Memory based features. Philips publication 9398 401 30011, (1985).
- 5 CCD video memory systems. Philips publication 9398 328 20011, (1985).

# Digital interfaces for component video signals

# AN ETV/IR89126

Author: A. H. Nillesen

Several coding parameters have to be specified for interconnecting the digital component video signals YD, UD and VD between several devices. For the digital studio environment the CCIR has made two recommendations on these parameters.

CCIR Recommendation 601 describes an extensive family of clock frequencies and the signal amplitudes, timing codes and auxiliary data for digital video component signals common to the 525- and 625-line TV standards. CCIR Recommendation 656 describes the means of interconnecting digital television equipment complying with the 4:2:2 encoding parameters as defined in Recommendation 601.

In the early eighties the basic sampling clock of digital circuits for TV receivers has been chosen, by Philips, Siemens and others, in accordance with the digital component studio standard CCIR Rec. 601, due to obvious benefits of having that parameter in common with the broadcasting side (e.g. MAC-decoding and descrambling). However with respect to signal amplitudes and multiplexing format a different choice was made. Possible benefits from the recommendations on these parameters were not seen, or considered as imaginary, whereas the drawbacks were considered as serious. This paper addresses the signal amplitudes and the multiplexing format which have been chosen for digital YUV interfaces in the TV receiver, including the extensions and revisions from later dates.

## 1. THE CONVERSION FACTOR

To express the amplitudes of the digital component signals, the conversion factor CF is defined as being the ratio between the digital and the normalized representation of the signal. Normalization is done to Red=Green=Blue=1 at peak white and the digital signals are represented on a scale of 256 (8 bits).

$$CF = \text{Conversion - Factor} = \frac{\text{digital signal amplitude on 8 bits scale}}{\text{normalised signal amplitude (R}_{\max} = G_{\max} = B_{\max} = 1)}$$

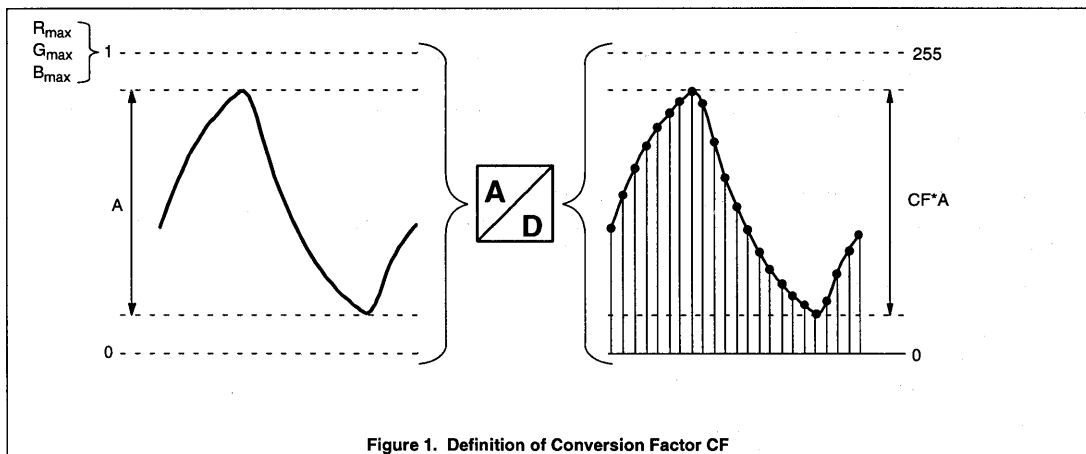

Figure 1. Definition of Conversion Factor CF

## 2. MAXIMUM AMPLITUDE OF NORMALIZED SIGNALS

With normalized signals the colour separation signals red, green and blue are unity at peak white:  $R_{\max}=G_{\max}=B_{\max}=1$ .

The colour equations for broadcast signals are based on the NTSC primaries as specified in CCIR Report 624-2. The resulting equation for the luminance signal is:

$$Y = 0.299 * R + 0.587 * G + 0.114 * B \quad (2.1)$$

which gives:  $Y_{p-p} = 1$

|B-Y| is maximum for R,G,B=0,0,1 (=blue)  
or R,G,B=1,1,0 (=yellow=white minus blue)

which gives:  $(B-Y)_{p-p} = 2 * (1 - 0.114) = 1.772$

|R-Y| is maximum for R,G,B=1,0,0 (=red)  
or R,G,B=0,1,1 (=cyan=white minus red)

which gives:  $(R-Y)_{p-p} = 2 * (1 - 0.299) = 1.402$

<p>maximum amplitudes of normalized signals  <math>Y_{p-p} = 1, (B-Y)_{p-p} = 1.772, (R-Y)_{p-p} = 1.402</math></p>
---

(2.2)

## Digital interfaces for these limits on component video signals

## AN ETV/IR89126

### 3. MAIN CODING PARAMETERS OF CCIR REC. 601/656

The digital component signals according to CCIR Rec. 601 have been chosen such that, coded in straight binary

- digital levels 0 and 255 are reserved for synchronization data.
- the luminance signal is to occupy only 220 quantisation levels, to provide working margins, and that black is at level 16.
- the colour difference signals are to occupy 225 quantisation levels and that the zero level is to be level 128 in order to cope with the bipolar nature of the colour difference signals.

The conversion factors follow from these limits on the digital signal range and the maximum peak-to-peak value of the normalized signals:

$$\text{signal}_{p-p} \cdot CF = \text{digital-limit}$$

**luminance:**  $Y_{p-p} \cdot CF_Y = 219$ , which gives  $CF_Y = 219$

**colour difference:**  $(B-Y)_{p-p} \cdot CF_U = 224$ ,  $CF_U = 126$   
 $(R-Y)_{p-p} \cdot CF_V = 224$ ,  $CF_V = 160$

The resulting digital component signals  $CY$ ,  $CU$ ,  $CV$  are: <sup>1)</sup>

CCIR digital YUV:

$$CY = 219 \cdot Y + 16$$

$$CU = 126 \cdot (B - Y) + 128$$

$$CV = 160 \cdot (R - Y) + 128$$

} binary coded

(3.1)

(3.2)

(3.3)

- the data words 0 and 255 are reserved for data identification
- the video data words are conveyed (CCIR Rec. 656) as a 27Mwords/second multiplex in the following order:  
 $CU, CY, CV, CY, CU, CY, CV$ , etc.

in which the word sequence  $CU, CY, CV$ , refers to cosited luminance and colour-difference samples and the following word,  $CY$ , corresponds to the next luminance sample.

### 4. PARAMETERS TO BE CONSIDERED FOR TV RECEIVERS

Without doubt the characteristics of analog or digital video component signals at broadcasting side and receiving end are quite different due to the large differences in environment and cost/performance. As a consequence the coding characteristics of digital interface signals are influenced differently by several parameters. Regarding signal amplitudes:

- maximum digital resolution should be balanced against:
- margin for static and dynamic amplitude changes, i.e. tolerances and multiplicative noise (echo, tilt).
- margin for additive noise.
- margin for filter overshoots
- probable limit on saturation

Also on the ratio between signal amplitudes some criteria should be considered:

- simple gain correction to normalized signals e.g. matrixing.
- simple correction between digital decoder and interface.

The list can be extended with requirements from EMC, limitations or advantages of certain IC technologies, application specific requirements etc. Although no choice is best in all cases, consensus is required on the major coding characteristics, due to obvious benefits of standardization. The agreement on this subject between system engineers from the Consumer-Electronics and the Components divisions of Philips (and others) will be explained in the following chapters.

### 5. MAIN CODING PARAMETERS FOR DIGITAL TV

The component video signals for digital TV are specified as:

digital TV signals:

$$YD = 192 \cdot Y + 16$$

$$UD = 3/4 \cdot 192 \cdot (B - Y)$$

$$VD = 192 \cdot (R - Y)$$

} straight binary

} two's-complement

(5.1)

(5.2)

(5.3)

- multiplex formats are specified for sampling ratios of 4:1:1 and 4:2:2

1) CCIR recommendations use different nomenclature:  $Y$ ,  $C_B$ ,  $C_R$ .

## Digital interfaces for component video signals

## AN ETV/IR89126

The colour difference signals are coded in two's complement in order to fit directly to digital arithmetic functions. The difference with the offset binary coding of the CCIR signals (3.1-3.3) is an inversion of the MSB. Concerning the specified conversion factors it will be shown that several criteria on the coding parameters are fulfilled simultaneously:

- digital resolution is practically optimum for 75% colour difference amplitudes.
- signal amplitudes fit conveniently to D2MAC decoders, taking into account 30% headroom for noise.
- UD/VD ratio fits conveniently to the required gain matching ratio for PAL/NTSC colour difference signals.
- amplitude margin is in accordance with the amplitude tolerance of analog decoded signals.
- matrixing to colour selection signals is simple

### 6. PEAK AMPLITUDE RATIOS

The amplitude ratios should be chosen such that

- the maximum amplitudes are more or less equal in order to maximize digital resolution
- simple gain ratios are required for matrixing
- required correction of the decoded signals is simple

in which 'simple' means that the required gain can be realized with very few additions.

#### 6.1. Probable Maximum Saturation

Due to the gamma of the picture tube the displayed saturation will be higher than the electrical saturation except at 100%. Saturation is less than 100% if the displayed colour has a certain white content, which means that none of the the RGB signals then becomes zero but have a minimum non-zero value. That minimum value becomes relatively smaller if it is displayed via the gamma of the picture tube.

The electrical saturation can be expressed as 
$$\frac{E_{\max} - E_{\min}}{E_{\max}} = 1 - \frac{E_{\min}}{E_{\max}}$$

from which follows: displayed saturation = 
$$1 - \left[ \frac{E_{\min}}{E_{\max}} \right]^{\text{gamma}}$$

in which  $E_{\min}$  is the minimum value of the RGB signals in coloured areas  
 $E_{\max}$  is the maximum value of the RGB signals in coloured areas  
 gamma is the gamma of the drive-to-output display characteristic.

As a consequence a minor reduction of the maximum displayed saturation will result in a significant reduction of the maximum amplitude of the colour difference signals, e.g. only 5% reduction of the maximum displayed saturation at maximum intensity results from 30% reduction of the electrical saturation at gamma=2.4.

Therefore it is important to take into account that it is most unlikely that natural scenes contain fully saturated colours at maximum intensity. PAL and NTSC have been specified such that at maximum saturation the modulated subcarrier would never swing 'blacker-than-black' by more than 33%. As a consequence the composite signal reaches 100% amplitude at 1/1.33=75% amplitude of saturated colours (yellow and cyan in 100.0.75.0 EBU colour bars). On the same ground also D2MAC colour difference signals are specified for only 77% maximum electrical amplitude. Furthermore the most common luminance step colour bar signals used as test signal result in colour difference signals at 75% of their theoretical maximum amplitude [1].

For these reasons it is supposed that the colour difference signals will most probably not exceed 75% of their theoretical maximum value, which corresponds to 96% maximum displayed saturation at a practical value of gamma=2.4. <sup>2)</sup>

#### 6.2. Ratio of Conversion Factors

For equal amplitudes of the digital signals the ratio of the conversion factors should be inversely proportional to the analog amplitudes. As a consequence the ratio of the conversion factors for equal peak amplitudes at 75% maximum electrical saturation is given by

$$CF_Y : CF_U : CF_V = \frac{1}{Y_{p-p}} : \frac{1}{0.75 * (B - Y)_{p-p}} : \frac{1}{0.75 * (R - Y)_{p-p}}$$

Substitution of (2.2) gives  $CF_Y:CF_U:CF_V=1.0.75:0.95$  which, after rounding to simple integers, results in:

$$CF_Y : CF_U : CF_V = 4 : 3 : 4$$

(6.2)

2) It should be noted that the gamma of TV cathode ray tubes is about 2.4 whereas the 'transmitted' gamma is nominally 2.8 which results in an overall gamma of 1.2.

## Digital interfaces for component video signals

## AN ETV/IR89126

With these simple factors, which will lead to simple (digital) matrixing for R and B, the probable maximum amplitudes of the digital signals are practically equal which gives optimum digital resolution.

### 6.3. U/V Gain Matching for PAL and NTSC

In NTSC and PAL the colour difference signals  $U=(B-Y)'$  and  $V=(R-Y)'$  used to modulate the subcarrier are reduced in amplitude with respect to the normalized signals:

$$U=0.493*(B-Y) \quad (6.3)$$

$$V=0.877*(R-Y) \quad (6.4)$$

As a consequence gain correction is required to obtain normalized signal amplitudes from the demodulated U and V signals. The required gain matching ratio, derived from (6.3) and (6.4), equals  $0.493/0.877=9/16$ . Therefore the ratio  $CF_u/CF_v=3/4$  fits very conveniently to the required gain matching ratio for U/V from decoded PAL or NTSC signals. If the decoded V signal is first reduced with 3/4 (one adder) then the remaining 'error' is 3/4, being the desired  $CF_u/CF_v$ . The final correction of 3/4, which will result in equal conversion factors, should then be applied just before or just after DA-conversion to obtain analog colour difference signals with normalized amplitudes, which is common practice for TV receivers.

## 7. DIGITAL SIGNAL AMPLITUDES

The worst case margins required for noise and amplitude tolerances are quite large. Linear or statistical addition of these margins would lead to insufficient digital resolution at quantisation in 8 bits. As an example, statistical addition of

- 30% headroom for noise (subchapter 7.1)
- 18% tolerance on transmitted burst-to-chrominance ratio [2]
- 2dB gain tolerance of analog decoders (subchapter 7.2)

would require a total range for the colour difference signals of more than two times the nominal value. Therefore the conversion factors have been chosen such

- that there is sufficient margin in amplitude to handle the tolerance of analog decoders

and

- that the margin is according to the 'headroom' for additive noise as proposed by the EBU for D2MAC signals.

If, for certain applications, the margin is considered as insufficient then a kind of gain control should be applied. Gain control on the CVBS signal in front of the digital decoder is already common practice (TDA8708). However automatic gain correction of component signals, i.e. signals originating from external RGB (SCART) or analog decoders, is far more complicated. Detection and control of the amplitudes should then be done on the three component signals simultaneously.

### 7.1. noise

The criterion for noise handling capability in this context is the probability that signal quality is degraded by noise clipping due to signal quantisation. A probability of one sample per line (about  $10^{-9}$ ) seems a reasonable measure for good noise behavior. Assuming that the noise has a Gaussian distribution (white noise), the peak value to be taken into account is then approximately three times the rms value, six times for the peak-to-peak value.

Signal-to-noise-ratios below 0dB are normal operating conditions in the design of TV circuits. E.g. for burst processing it is common practice to design the subcarrier regenerator for stable output (less than 5 degree rms phase noise) at  $S/N=-10$ dB ( $CVBS_{p-p}/Noise_{rms}$ ) [3]. In that case the required margin for noise amplitude would be approximately twenty times larger than the CVBS signal amplitude.

Although it is unlikely that such a margin is present in the analog prestages at nominal CVBS amplitude, it is obvious that a compromise is necessary between quantisation noise and the margin for external noise. Therefore the worst probable case of S/N for D2MAC reception is used as a guideline [4].

In the D2MAC system the carrier is frequency-modulated by the baseband signal [5]. In FM systems there is a rather sharp threshold between carrier-to-noise ratios for 'good' and 'bad' S/N of the demodulated signal. Therefore the assumption is made that the worst probable S/N for D2MAC reception occurs at a carrier-to-noise ratio of 11dB, just above the threshold. That results in an unweighted noise level of about -26dB ( $=0.05$ ) [4,6] for the demodulated signal (depending on the filter response of the prestages). That means that  $6*0.05=30\%$  headroom has to be taken into account for additive noise.

### 7.2. MAC Decoder

MAC decoding in principle is time-demultiplexing. Therefore the MAC decoder is transparent (no internal gain) with respect to digital amplitudes. If the MAC (mid-range) clamping level is referred to as zero and if the peak-to-peak range is unity, then the MAC signals according to the D2-MAC specification [5] are transmitted as:

$$Y_m=Y-0.5, \quad U_m=0.733*(B-Y) \quad \text{and} \quad V_m=0.927*(R-Y) \quad (7.1)$$

3) In NTSC the vectors I and Q are also derived from  $(B-Y)'$  and  $(R-Y)'$ .



# Digital interfaces for component video signals

# AN ETV/IR89126

It is supposed that regarding DC level:

- the digitized grey clamping level equals 128 (analog 'zero' becomes digital 128)

and regarding AC input:

- the ratio between the nominal digital peak-to-peak amplitude and the maximum range (256) of the ADC equals MR (Modulation Range).

then the corresponding digital component signals will be (See Fig. 2):

$$MY = 128 + MR * 256 * (Y - 0.5) \tag{7.2}$$

$$MU = 128 + MR * 256 * 0.733 * (B - Y) \tag{7.3}$$

$$MV = 128 + MR * 256 * 0.927 * (R - Y) \tag{7.4}$$

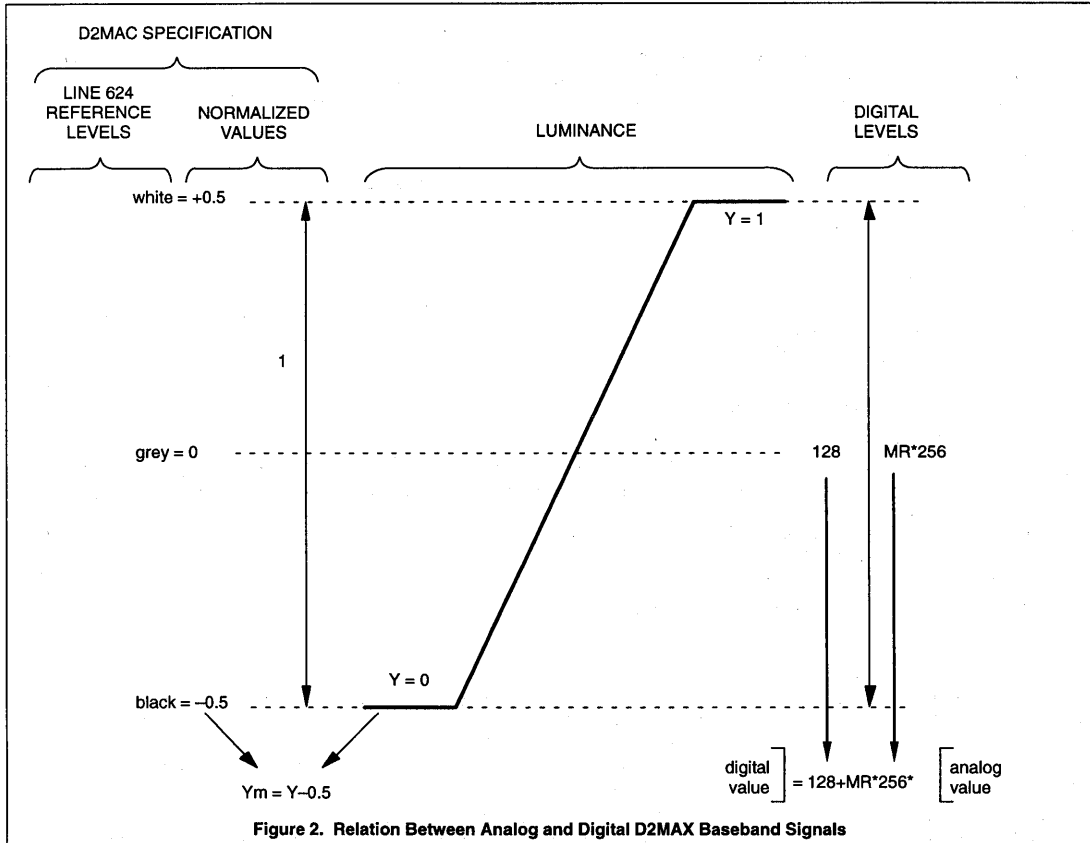

4) The colour difference signals in the D2MAC multiplex are scaled to unity amplitude at 77% of their maximum value. As a consequence the scale factors for B-Y and R-Y are  $1/(0.77 * 1.772) = 0.733$  and  $1/(0.77 * 1.402) = 0.927$  respectively.

## Digital interfaces for component video signals

## AN ETV/IR89126

With 30% headroom for additive noise ( $MR=0.77$ ) the decoded signals (7.2)-(7.4) and the resulting conversion factors become:

$$MY=197*Y+29 \quad CF_y=197 \quad (7.5)$$

$$MU=144*(B-Y)+128 \quad CF_u=3/4*192 \quad (7.6)$$

$$MV=183*(R-Y)+128 \quad CF_v=183=192/1.05 \quad (7.7)$$

Consequences for interfacing:

- luminance black level should be corrected to 16 (one adder).
- error on  $CF_y$  results in an acceptable saturation error
- V-signal has to be corrected with  $192/183w17/16*63/64$  (two adders)
- no correction is needed for the U-signal

### 7.3. Analog Decoder

An accepted value for the specified tolerance on the output signals of analog colour decoders (e.g.TDA4555) is +/-2dB (0.8-1.25). With a fixed digital black level of 16 the available range for luminance is  $255-16+1=240$ . Reduction with 2dB, rounded to the nearest multiple of 4 (resulting in an integer value for  $CF_u$ ), gives a nominal range of 192. That means that the digital interface signals ( $CF_y=192$ ) can also handle the amplitude tolerance of analog decoders.

### 7.4. Digital PAL Decoder

In PAL and NTSC decoders the amplitude of the demodulated U and V signals is, via action of Automatic Colour Control (ACC), directly related to the amplitude of the colour burst. For PAL the relation can be derived from

$$BP=\text{peak burst amplitude}=3/7$$

Substitution in in (6.3) and (6.4) gives

$$U=1.15*BP*(B-Y) \quad \text{and} \quad V=2.05*BP*(R-Y) \quad (7.8)$$

If the burst peak amplitude in the digital PAL decoder is kept at  $BP=125$  and the amplitude of the V signal is reduced with 3/4 then the resulting UD and VD signals become:

$$UD=1.15*125*(B-Y)=3/4*192*(B-Y) \quad (7.9)$$

$$VD=3/4*2.05*125*(R-Y)=192*(R-Y) \quad (7.10)$$

which is in accordance with the desired interface signals (5.1)-(5.3).

### 7.5. Digital Matrixing

For certain applications, e.g. gamma correction for LCD, it might be required to operate on colour separation signals rather than colour difference signals. With six adders the YD, UD and VD signals can be matrixed to digital luminance, red and blue signals normalized to a conversion factor of 216.

$$\text{luminance:} \quad 216*Y=9/8*YD \quad (\text{one adder}) \quad (7.11)$$

$$\text{red:} \quad 216*R=9/8*YD+3/2*UD \quad (\text{three adders}) \quad (7.12)$$

$$\text{blue:} \quad 216*B=9/8*(YD+VD) \quad (\text{two adders}) \quad (7.13)$$

These signals cover 90% (216) of the total range from black (16) to maximum (255).

## 8. DATA MULTIPLEXING

The video interface signal according to CCIR Rec.656 is based on 4:2:2 sample ratio. For digital TV the 4:1:1 sample ratio is an attractive alternative, in particular for memory based processing of video originating from decoded CVBS signals. Therefore data formats have been specified for 4:1:1 and 4:2:2. The luminance and colour difference signals are conveyed as separate data with identical clock rate according to the luminance sample rate, 13.5MHz or 27MHz in case of frequency doubling. Luminance data is transferred on eight data lines, whereas the colour difference signals are multiplexed on four or eight data lines.

The 4:2:2 multiplex format is chosen such that it can simply be made from the multiplexed data according to CCIR Rec.656. In the 4:1:1 format the UD and VD signals are multiplexed on separate data lines. The multiplex formats of the colour difference samples are given in the following tables together with the cosited luminance sample.

# Digital interfaces for component video signals

# AN ETV/IR89126

'4:2:2' format

dataline	samplebits	
Y7	T7	next Y
Y6	Y6	
...	...	
Y0	Y0	
C7	U7	V7
C6	U6	V6
...	...	...
C0	U0	V0
time-slot	0	1

'4:1:1' format

dataline	samplebits			
Y7	Y7	next Y-samples		
Y6	Y6			
...	...			
Y0	Y0			
C7	U7	U5	U3	U1
C6	U6	U4	U2	U0
C5	V7	V5	V3	V1
C4	V6	V4	V2	V0
time-slot	0	1	2	3

The start of the multiplex frame is identified by the positive going edge of a control signal (BLN or HREF or MUX, depending on the integrated circuit used as source).

## 9. CONCLUSION

Signal amplitudes and multiplexing formats for digital component video signals as used for interconnecting TV receiver functions are based on receiver specific requirements. Concerning amplitudes the following criteria are fulfilled:

- digital resolution is practically optimum for 75% colour difference amplitudes.
- signal amplitudes fit conveniently to D2MAC decoders, taking into account 30% headroom for noise.
- UD/VD ratio fits conveniently to the required gain matching ratio for PAL/NTSC colour difference signals.
- amplitude margin is in accordance with the amplitude tolerance of analog decoded signals.
- matrixing to colour selection signals is simple Data multiplexing parameters are specified for:
- 4:2:2 as well as 4:1:1 sample frequency ratio to cope with different bandwidths, in particular for memory applications
- clock frequency equal to luminance sample frequency for application with or without frequency doubling

The following figures give the characteristic amplitudes of the digital component video signals according to the specifications for application in TV receivers and according to CCIR Rec.601.

Digital interfaces for component video signals

AN ETV/IR89126

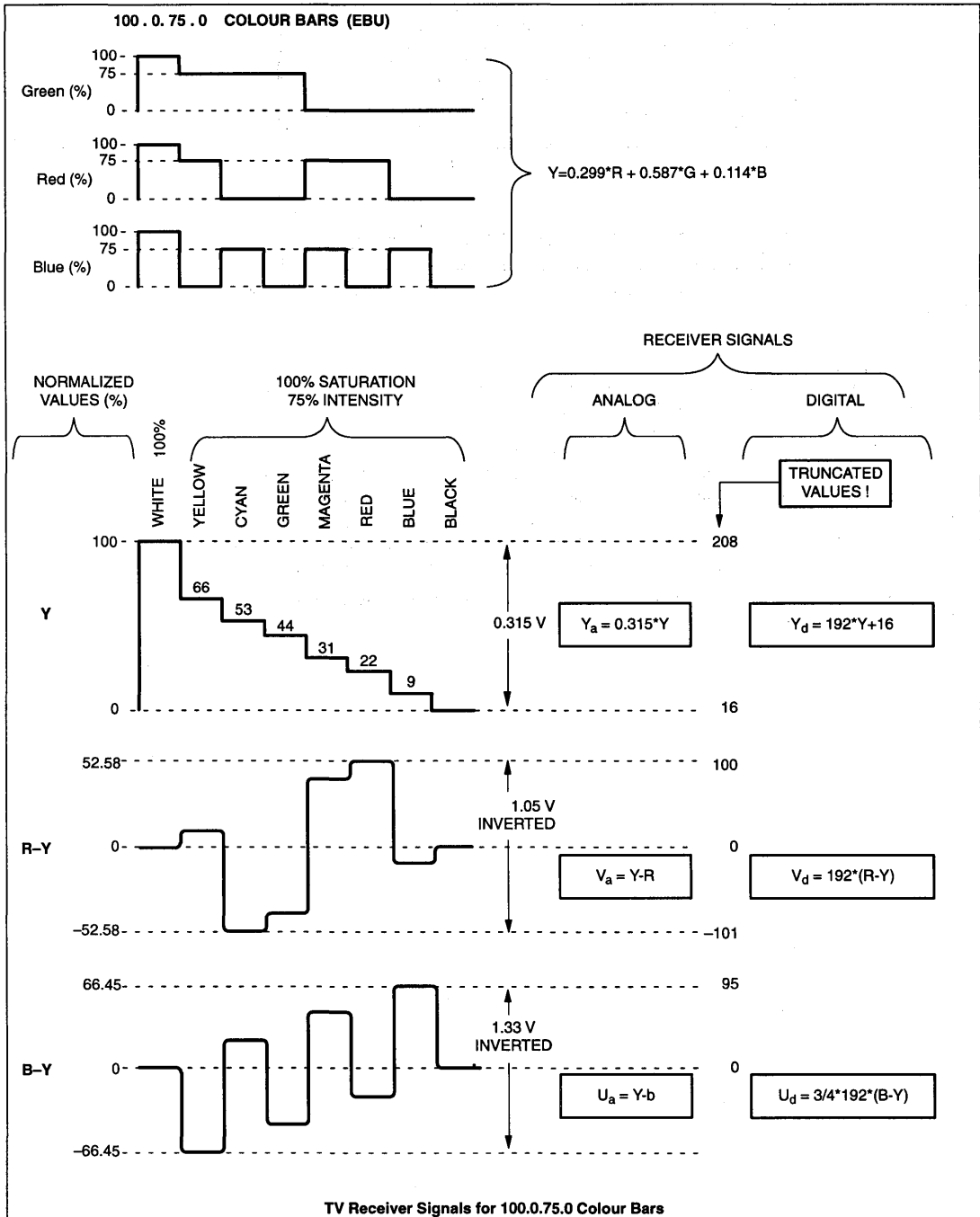

# Digital interfaces for component video signals

# AN ETV/IR89126

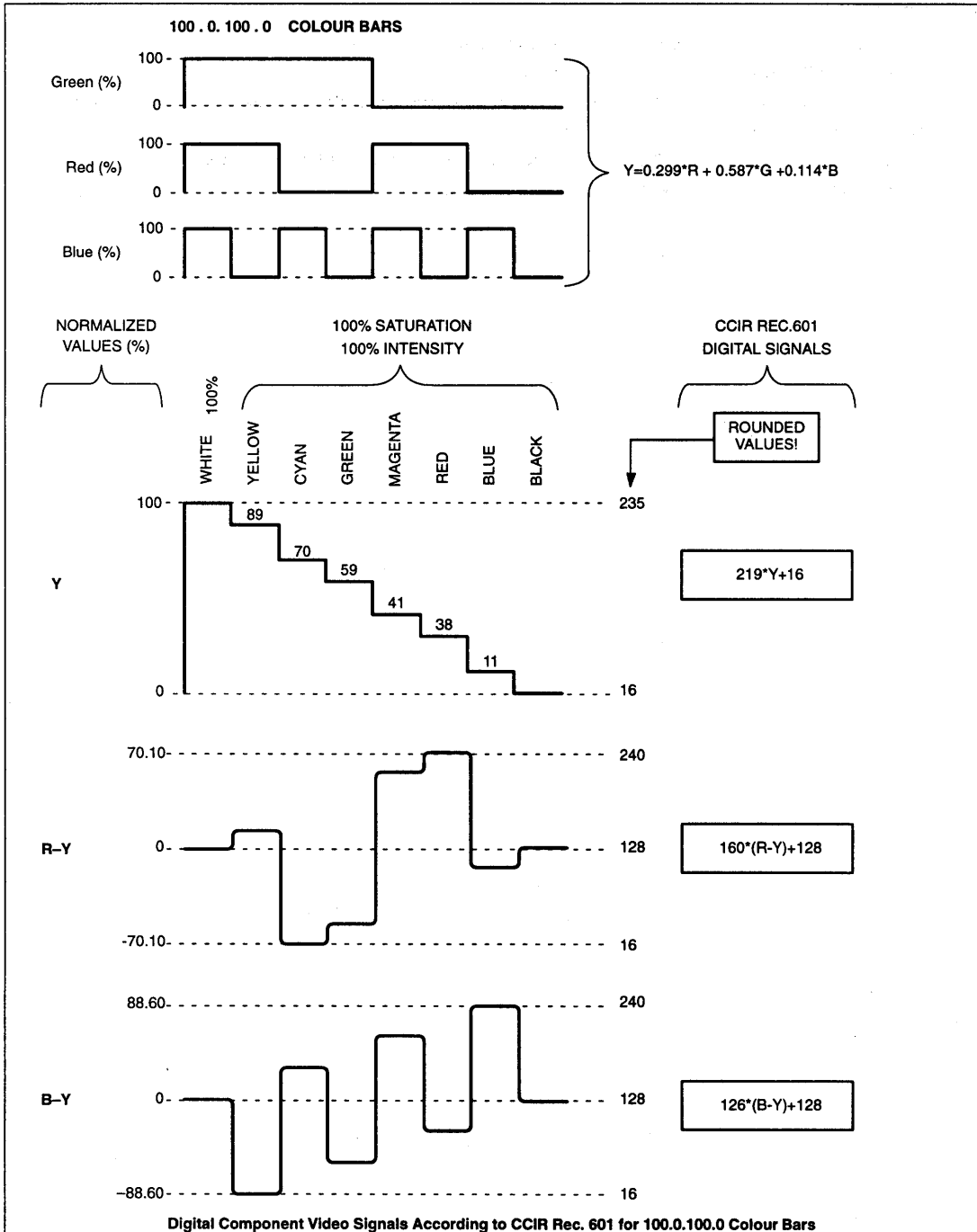

---

# Digital interfaces for component video signals AN ETV/IR89126

---

## REFERENCES

- [1] CCIR Recommendation 471-1; "Nomenclature and description of colour bar signals"
- [2] IBA Technical Review, part 2 Technical Reference Book, July 1974
- [3] Donald Richman; Proc. IRE, vol. 43, 1954; "Colour-carrier reference phase synchronization accuracy in NTSC colour television"
- [4] Appendix to part 2 of [5]; "Guidelines for system implementation"
- [5] EBU Technical centre; Tech.3258-E; October 1986; "Specification of the systems of the MAC/packet family"
- [6] Arno Neelen, Philips Components division, PCALE; private communication.

# Encoding parameters of digital television for studios CCIR REC. 601-2

## RECOMMENDATION 601-2

### ENCODING PARAMETERS OF DIGITAL TELEVISION FOR STUDIOS\*

(Question 25/11, Study Programmes 25G/11, 25H/11)

(1982-1986-1990)

The CCIR,

#### CONSIDERING

- (a) that there are clear advantages for television broadcasters and programme producers in digital studio standards which have the greatest number of significant parameter values common to 525-line and 625-line systems;
- (b) that a world-wide compatible digital approach will permit the development of equipment with many common features, permit operating economies and facilitate the international exchange of programmes;
- (c) that an extensible family of compatible digital coding standards is desirable. Members of such a family could correspond to different quality levels, facilitate additional processing required by present production techniques, and cater for future needs;
- (d) that a system based on the coding of components is able to meet some, and perhaps all, of these desirable objectives;
- (e) that the co-siting of samples representing luminance and colour-difference signals (or, if used, the red, green and blue signals) facilitates the processing of digital component signals, required by present production techniques,

#### UNANIMOUSLY RECOMMENDS

that the following be used as a basis for digital coding standards for television studios in countries using the 525-line system as well as in those using the 625-line system:

#### 1. Component coding

The digital coding should be based on the use of one luminance and two colour-difference signals (or, if used, the red, green and blue signals).

The spectral characteristics of the signals must be controlled to avoid aliasing whilst preserving the passband response. When using one luminance and two colour-difference signals as defined in Table I of RECOMMENDS 4, suitable filters are defined in Annex III, Figs. 1 and 2. When using the  $E'_R$ ,  $E'_G$ ,  $E'_B$  signals or luminance and colour-difference signals as defined in Table II of Annex I, a suitable filter characteristic is shown in Fig. 1 of Annex III.

\* Main digital television terms used in the Recommendation are defined in Report 629.

---

## Encoding parameters of digital television for studios CCIR REC. 601-2

---

### 2. Extensible family of compatible digital coding standards

The digital coding should allow the establishment and evolution of an extensible family of compatible digital coding standards.

It should be possible to interface simply between any two members of the family.

The member of the family to be used for the standard digital interface between main digital studio equipment, and for international programme exchange (i.e. for the interface with video recording equipment and for the interface with the transmission system) should be that in which the luminance and colour-difference sampling frequencies are related in the ratio 4 : 2 : 2.

In a possible higher member of the family the sampling frequencies of the luminance and colour-difference signals (or, if used, the red, green and blue signals) could be related by the ratio 4 : 4 : 4. Tentative specifications for the 4 : 4 : 4 member are included in Annex I (see Note).

*Note* — Administrations are urgently requested to conduct further studies in order to specify parameters of the digital standards for other members of the family. Priority should be accorded to the members of the family below 4 : 2 : 2. The number of additional standards specified should be kept to a minimum.

### 3. Specifications applicable to any member of the family

3.1 Sampling structures should be spatially static. This is the case, for example, for the orthogonal sampling structure specified in § 4 of the present Recommendation for the 4 : 2 : 2 member of the family.

3.2 If the samples represent luminance and two simultaneous colour-difference signals, each pair of colour-difference samples should be spatially co-sited. If samples representing red, green and blue signals are used they should be co-sited.

3.3 The digital standard adopted for each member of the family should permit world-wide acceptance and application in operation; one condition to achieve this goal is that, for each member of the family, the number of samples per line specified for 525-line and 625-line systems shall be compatible (preferably the same number of samples per line).

### 4. Encoding parameter values for the 4 : 2 : 2 member of the family

The following specification (Table I) applies to the 4 : 2 : 2 member of the family, to be used for the standard digital interface between main digital studio equipment and for international programme exchange.



TABLE I — Encoding parameter values for the 4 : 2 : 2 member of the family

Parameters	525-line, 60 field/s <sup>(1)</sup> systems	625-line, 50 field/s <sup>(1)</sup> systems
1. Coded signals: $Y$ , $C_R$ , $C_B$	These signals are obtained from gamma pre-corrected signals, namely: $E'_Y$ , $E'_R - E'_Y$ , $E'_B - E'_Y$ (Annex II, § 2 refers)	
2. Number of samples per total line: – luminance signal ( $Y$ ) – each colour-difference signal ( $C_R$ , $C_B$ )	858 429	864 432
3. Sampling structure	Orthogonal, line, field and frame repetitive. $C_R$ and $C_B$ samples co-sited with odd (1st, 3rd, 5th, etc.) $Y$ samples in each line	
4. Sampling frequency: – luminance signal – each colour-difference signal	13.5 MHz <sup>(2)</sup> 6.75 MHz <sup>(2)</sup>  The tolerance for the sampling frequencies should coincide with the tolerance for the line frequency of the relevant colour television standard	
5. Form of coding	Uniformly quantized PCM, 8 bits per sample, for the luminance signal and each colour-difference signal	
6. Number of samples per digital active line: – luminance signal – each colour-difference signal	720 360	
7. Analogue-to-digital horizontal timing relationship: – from end of digital active line to $0_H$	16 luminance clock periods	12 luminance clock periods
8. Correspondence between video signal levels and quantization levels: – scale – luminance signal – each colour-difference signal	0 to 255  220 quantization levels with the black level corresponding to level 16 and the peak white level corresponding to level 235. The signal level may occasionally exceed beyond level 235  225 quantization levels in the centre part of the quantization scale with zero signal corresponding to level 128	
9. Code-word usage	Code-words corresponding to quantization levels 0 and 255 are used exclusively for synchronization. Levels 1 to 254 are available for video	

<sup>(1)</sup> See Report 624, Table I.<sup>(2)</sup> The sampling frequencies of 13.5 MHz (luminance) and 6.75 MHz (colour-difference) are integer multiples of 2.25 MHz, the lowest common multiple of the line frequencies in 525/60 and 625/50 systems, resulting in a static orthogonal sampling pattern for both.

## ANNEX I

## TENTATIVE SPECIFICATION OF THE 4 : 4 : 4 MEMBER OF THE FAMILY

This Annex provides for information purposes a tentative specification for the 4 : 4 : 4 member of the family of digital coding standards.

The following specification could apply to the 4 : 4 : 4 member of the family suitable for television source equipment and high quality video signal processing applications.

TABLE II — *A tentative specification for the 4 : 4 : 4 member of the family*

Parameters	525-line, 60 field/s systems	625-line, 50 field/s systems
1. Coded signals: $Y$ , $C_R$ , $C_B$ or $R$ , $G$ , $B$	These signals are obtained from gamma pre-corrected signals, namely: $E'_Y$ , $E'_R - E'_Y$ , $E'_B - E'_Y$ or $E'_R$ , $E'_G$ , $E'_B$	
2. Number of samples per total line for each signal	858	864
3. Sampling structure	Orthogonal, line, field and frame repetitive. The three sampling structures to be coincident and coincident also with the luminance sampling structure of the 4 : 2 : 2 member	
4. Sampling frequency for each signal	13.5 MHz	
5. Form of coding	Uniformly quantized PCM. At least 8 bits per sample	
6. Duration of the digital active line expressed in number of samples	At least 720	
7. Correspondence between video signal levels and the 8 most significant bits (MBS) of the quantization level for each sample:	<ul style="list-style-type: none"> <li>— scale 0 to 255</li> <li>— <math>R</math>, <math>G</math>, <math>B</math> or luminance signal (*) 220 quantization levels with the black level corresponding to level 16 and the peak with level corresponding to level 235. The signal level may occasionally excure beyond level 235</li> <li>— each colour-difference signal (*) 225 quantization levels in the centre part of the quantization scale with zero signal corresponding to level 128</li> </ul>	

(\*) If used.

## ANNEX II

## DEFINITION OF SIGNALS USED IN THE DIGITAL CODING STANDARDS

## 1. Relationship of digital active line to analogue sync. reference

The relationship between 720 digital active line luminance samples and the analogue synchronizing references for 625-line and 525-line systems is shown below.

TABLE III

525-line, 60 field/s systems	122 $T$	720 $T$	16 $T$	
	$0_H$ (leading edge of line syncs., half-amplitude reference)	Digital active-line period		Next line $0_H$
625-line, 50 field/s systems	132 $T$	720 $T$	12 $T$	

$T$ : one luminance sampling clock period (74 ns nominal).

The respective numbers of colour-difference samples can be obtained by dividing the number of luminance samples by two. The (12, 132) and (16, 122) were chosen symmetrically to dispose the digital active line about the permitted variations. They do not form part of the digital line specification and relate only to the analogue interface.

2. Definition of the digital signals  $Y$ ,  $C_R$ ,  $C_B$ , from the primary (analogue) signals  $E'_R$ ,  $E'_G$  and  $E'_B$ 

This section describes, with a view to defining the signals  $Y$ ,  $C_R$ ,  $C_B$ , the rules for construction of these signals from the primary analogue signals  $E'_R$ ,  $E'_G$  and  $E'_B$ . The signals are constructed by following the three stages described in § 2.1, 2.2 and 2.3 below. The method is given as an example, and in practice other methods of construction from these primary signals or other analogue or digital signals may produce identical results. An example is given in § 2.4.

2.1 Construction of luminance ( $E'_Y$ ) and colour-difference ( $E'_R - E'_Y$ ) and ( $E'_B - E'_Y$ ) signals

The construction of luminance and colour-difference signals is as follows:

$$E'_Y = 0.299E'_R + 0.587E'_G + 0.114E'_B \quad (\text{See Note})$$

whence:

$$\begin{aligned} (E'_R - E'_Y) &= E'_R - 0.299E'_R - 0.587E'_G - 0.114E'_B \\ &= 0.701E'_R - 0.587E'_G - 0.114E'_B \end{aligned}$$

and:

$$\begin{aligned} (E'_B - E'_Y) &= E'_B - 0.299E'_R - 0.587E'_G - 0.114E'_B \\ &= -0.299E'_R - 0.587E'_G + 0.886E'_B \end{aligned}$$

Note. — Report 624 Table II refers.

Taking the signal values as normalized to unity (e.g., 1.0 V maximum levels), the values obtained for white, black and the saturated primary and complementary colours are as follows:

TABLE IV

Condition	$E'_R$	$E'_G$	$E'_B$	$E'_Y$	$E'_R - E'_Y$	$E'_B - E'_Y$
White	1.0	1.0	1.0	1.0	0	0
Black	0	0	0	0	0	0
Red	1.0	0	0	0.299	0.701	-0.299
Green	0	1.0	0	0.587	-0.587	-0.587
Blue	0	0	1.0	0.114	-0.114	0.886
Yellow	1.0	1.0	0	0.886	0.114	-0.886
Cyan	0	1.0	1.0	0.701	-0.701	0.299
Magenta	1.0	0	1.0	0.413	0.587	0.587

## 2.2 Construction of re-normalized colour-difference signals ( $E'_{C_R}$ and $E'_{C_B}$ )

Whilst the values for  $E'_Y$  have a range of 1.0 to 0, those for  $(E'_R - E'_Y)$  have a range of +0.701 to -0.701 and for  $(E'_B - E'_Y)$  a range of +0.886 to -0.886. To restore the signal excursion of the colour-difference signals to unity (i.e. +0.5 to -0.5), coefficients can be calculated as follows:

$$K_R = \frac{0.5}{0.701} = 0.713; K_B = \frac{0.5}{0.886} = 0.564$$

Then:

$$E'_{C_R} = 0.713 (E'_R - E'_Y) = 0.500E'_R - 0.419E'_G - 0.081E'_B$$

and:

$$E'_{C_B} = 0.564 (E'_B - E'_Y) = -0.169E'_R - 0.331E'_G + 0.500E'_B$$

where  $E'_{C_R}$  and  $E'_{C_B}$  are the re-normalized red and blue colour-difference signals respectively (see Notes 1 and 2).

*Note 1* - The symbols  $E'_{C_R}$  and  $E'_{C_B}$  will be used only to designate re-normalized colour-difference signals, i.e. having the same nominal peak-to-peak amplitude as the luminance signal  $E'_Y$ , thus selected as the reference amplitude.

*Note 2* - In the circumstances when the component signals are not normalized to a range of 1 to 0, for example, when converting from analogue component signals with unequal luminance and colour-difference amplitudes, an additional gain factor will be necessary and the gain factors  $K_R$ ,  $K_B$  should be modified accordingly.

### 2.3 Quantization

In the case of a uniformly-quantized 8-bit binary encoding,  $2^8$ , i.e. 256, equally spaced quantization levels are specified, so that the range of the binary numbers available is from 0000 0000 to 1111 1111 (00 to FF in hexadecimal notation), the equivalent decimal numbers being 0 to 255, inclusive.

In the case of the 4:2:2 system described in this Recommendation, levels 0 and 255 are reserved for synchronization data, while levels 1 to 254 are available for video.

Given that the luminance signal is to occupy only 220 levels, to provide working margins, and that black is to be at level 16, the decimal value of the luminance signal,  $\bar{Y}$ , prior to quantization, is:

$$\bar{Y} = 219 (E'_Y) + 16,$$

and the corresponding level number after quantization is the nearest integer value.

Similarly, given that the colour-difference signals are to occupy 225 levels and that the zero level is to be level 128, the decimal values of the colour-difference signals,  $\bar{C}_R$  and  $\bar{C}_B$ , prior to quantization are:

$$\bar{C}_R = 224 [0.713 (E'_R - E'_Y)] + 128$$

and:

$$\bar{C}_B = 224 [0.564 (E'_B - E'_Y)] + 128$$

which simplify to the following:

$$\bar{C}_R = 160 (E'_R - E'_Y) + 128$$

and:

$$\bar{C}_B = 126 (E'_B - E'_Y) + 128$$

and the corresponding level number, after quantization, is the nearest integer value.

The digital equivalents are termed  $Y$ ,  $C_R$  and  $C_B$ .

### 2.4 Construction of $Y$ , $C_R$ , $C_B$ via quantization of $E'_R$ , $E'_G$ , $E'_B$

In the case where the components are derived directly from the gamma pre-corrected component signals  $E'_R$ ,  $E'_G$ ,  $E'_B$ , or directly generated in digital form, then the quantization and encoding shall be equivalent to:

$$E'_{R_d} \text{ (in digital form)} = \text{int} (219 E'_R) + 16$$

$$E'_{G_d} \text{ (in digital form)} = \text{int} (219 E'_G) + 16$$

$$E'_{B_d} \text{ (in digital form)} = \text{int} (219 E'_B) + 16$$

Then:

$$Y = \frac{77}{256} E'_{R_d} + \frac{150}{256} E'_{G_d} + \frac{29}{256} E'_{B_d}$$

$$C_R = \frac{131}{256} E'_{R_d} - \frac{110}{256} E'_{G_d} - \frac{21}{256} E'_{B_d} + 128$$

$$C_B = -\frac{44}{256} E'_{R_d} - \frac{87}{256} E'_{G_d} + \frac{131}{256} E'_{B_d} + 128$$

taking the nearest integer coefficients, base 256. To obtain the 4:2:2 components  $Y$ ,  $C_R$ ,  $C_B$ , low-pass filtering and sub-sampling must be performed on the 4:4:4  $C_R$ ,  $C_B$  signals described above. Note should be taken that slight differences could exist between  $C_R$ ,  $C_B$  components derived in this way and those derived by analogue filtering prior to sampling.

ANNEX III

FILTERING CHARACTERISTICS

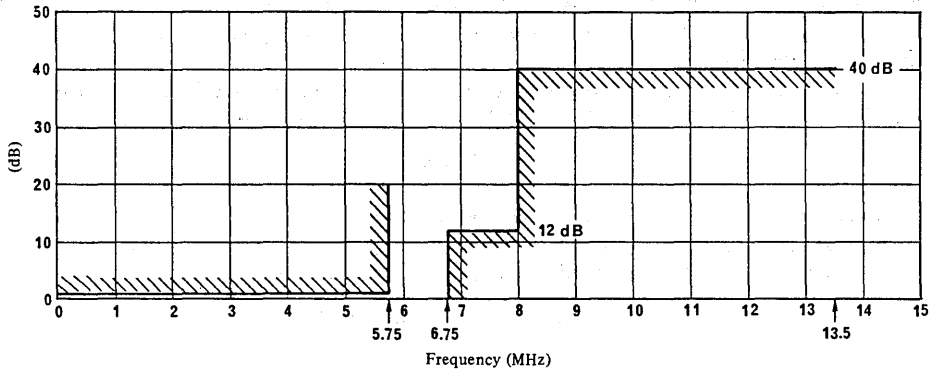

a) Template for insertion loss/frequency characteristic

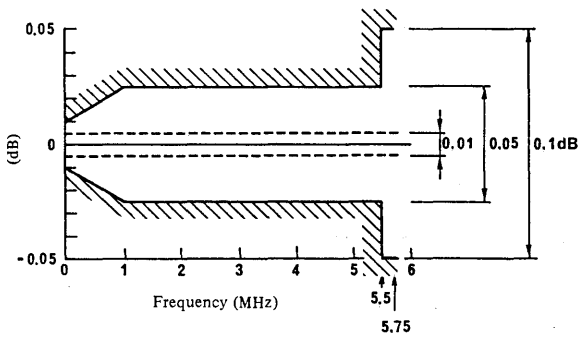

b) Passband ripple tolerance

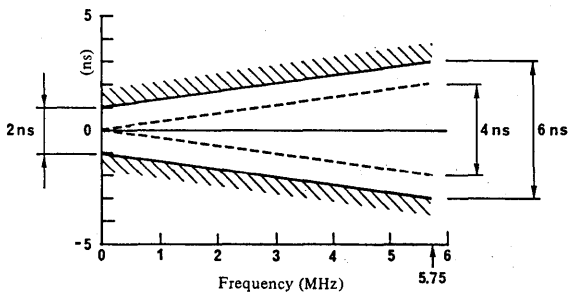

c) Passband group-delay tolerance

FIGURE 1 - Specification for a luminance or RGB signal filter used when sampling at 13.5 MHz

Note - The lowest indicated values in b) and c) are for 1 kHz (instead of 0 MHz).

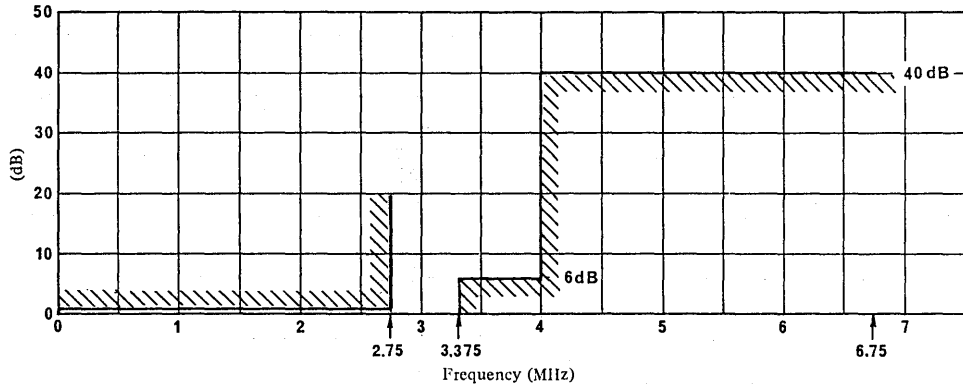

a) Template for insertion loss/frequency characteristic

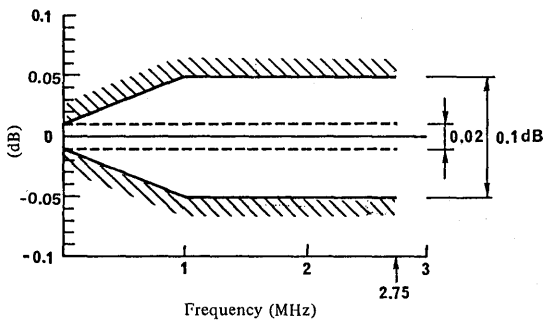

b) Passband ripple tolerance

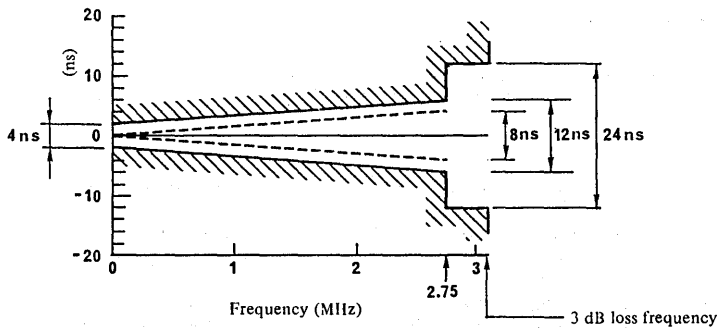

c) Passband group-delay tolerance

FIGURE 2 – Specification for a colour-difference signal filter used when sampling at 6.75 MHz

Note. – The lowest indicated values in b) and c) are for 1 kHz (instead of 0 MHz).

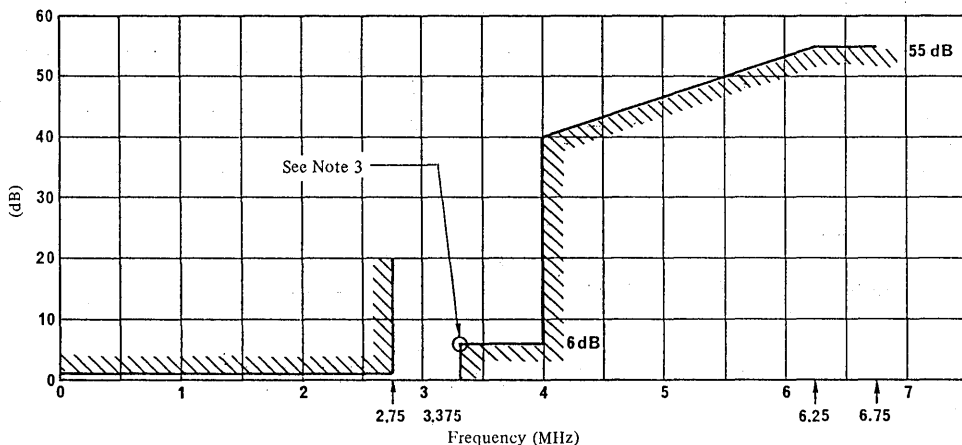

a) Template for insertion loss/frequency characteristic

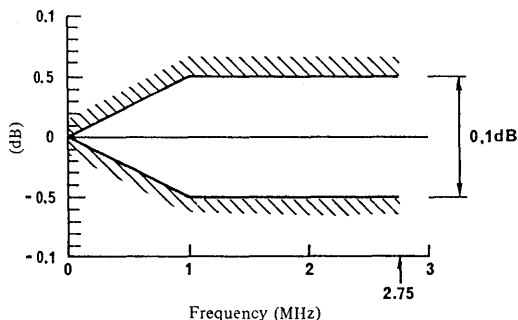

b) Passband ripple tolerance

FIGURE 3 – Specification for a digital filter for sampling-rate conversion from 4 : 4 : 4 to 4 : 2 : 2 colour-difference signals

Notes to Figs. 1, 2 and 3:

Note 1 – Ripple and group delay are specified relative to their values at 1 kHz. The full lines are practical limits and the dashed lines give suggested limits for the theoretical design.

Note 2 – In the digital filter, the practical and design limits are the same. The delay distortion is zero, by design.

Note 3 – In the digital filter (Fig. 3), the amplitude/frequency characteristic (on linear scales) should be skew-symmetrical about the half-amplitude point, which is indicated on the figure.

Note 4 – In the proposals for the filters used in the encoding and decoding processes, it has been assumed that, in the post-filters which follow digital-to-analogue conversion, correction for the  $(\sin x/x)$  characteristic of the sample-and-hold circuits is provided.



---

## RECOMMENDATIONS OF THE CCIR, 1990

CCIR 656

---

*(ALSO RESOLUTIONS AND OPINIONS) VOLUME XI — PART 1  
BROADCASTING SERVICE (TELEVISION)*

### CCIR

1. The International Radio Consultative Committee (CCIR) is the permanent organ of the International Telecommunication Union responsible under the International Telecommunication Convention "...to study technical and operating questions relating specifically to radiocommunications without limit of frequency range, and to issue recommendations on them..." (International Telecommunication Convention, Nairobi 1982, First Part, Chapter I, Art. 11, No. 83).<sup>1</sup>
2. The objectives of the CCIR are in particular:
  - a. to provide the technical bases for use by administrative radio conferences and radiocommunication services for efficient utilization of the radio-frequency spectrum and the geostationary-satellite orbit, bearing in mind the needs of the various radio services;
  - b. to recommend performance standards for radio systems and technical arrangements which assure their effective and compatible interworking in international telecommunications;
  - c. to collect, exchange, analyze and disseminate technical information resulting from studies by the CCIR, and other information available, for the development, planning and operation of radio systems, including any necessary special measures required to facilitate the use of such information in developing countries.

---

1. See also the Constitution of the ITU, Nice, 1989, Chapter 1, Art. 11, No. 84.

## Rec. 656

## RECOMMENDATION 656

**INTERFACES FOR DIGITAL COMPONENT VIDEO SIGNALS  
IN 525-LINE AND 625-LINE TELEVISION SYSTEMS**

(1986)

The CCIR,

## CONSIDERING

- a. that there are clear advantages for television broadcasting organizations and programme producers in digital studio standards which have the greatest number of significant parameter values common to 525-line and 625-line systems;
- b. that a world-wide compatible digital approach will permit the development of equipment with many common features, permit operating economies and facilitate the international exchange of programmes;
- c. that to implement the above objectives, agreement has been reached on the fundamental encoding parameters of digital television for studios in the form of Recommendation 601;
- d. that the practical implementation of Recommendation 601 requires definition of details of interfaces and the data streams traversing them;
- e. that such interfaces should have a maximum of commonality between 525-line and 625-line versions;
- f. that in the practical implementation of Recommendation 601 it is desirable that interfaces be defined in both serial and parallel forms;
- g. that digital television signals produced by these interfaces may be a potential source of interference to other services, and due notice must be taken of No. 964 of the Radio Regulations,

## UNANIMOUSLY RECOMMENDS

that where interfaces are required for component-coded digital video signals in television studios, the interfaces and the data streams that will traverse them should be in accordance with the following description, defining both bit-parallel and bit-serial implementations.

**1. Introduction**

This Recommendation describes the means of interconnecting digital television equipment operating on the 525-line or 625-line standards and complying with the 4 : 2 : 2 encoding parameters as defined in Recommendation 601.

Part I describes the signal format common to both interfaces.

Part II describes the particular characteristics of the bit-parallel interface.

Part III describes the particular characteristics of the bit-serial interface.

## PART I

## COMMON SIGNAL FORMAT OF THE INTERFACES

**1. General description of the interfaces**

The interfaces provide a unidirectional interconnection between a single source and a single destination.

A signal format common to both parallel and serial interfaces is described in § 2 below.

## Rec. 656

The data signals are in the form of binary information coded in 8-bit words. These signals are:

- video data;
- timing reference codes;
- ancillary data;
- identification codes.

## 2. Video data

### 2.1 Coding characteristics

The video data is in compliance with Recommendation 601, and with the field-blanking definition shown in Table 1.

TABLE I — Field interval definitions

		625	525
V-digital field blanking			
Field 1	Finish (V = 0)	Line 624	Line 1
	Start (V = 1)	Line 23	Line 10
Field 2	Start (V = 1)	Line 311	Line 264
	Finish (V = 0)	Line 336	Line 273
F-digital field identification			
Field 1	F = 0	Line 1	Line 4
Field 2	F = 1	Line 313	Line 266

*Note 1* — Signals F and V change state synchronously with the end of active video timing reference code at the beginning of the digital line.

*Note 2* — Definition of line numbers is to be found in Report 624. Note that digital line number changes state prior to  $0_{\mu}$  as shown in Fig. 1.

### 2.2 Video data format

The data words 0 and 255 (00 and FF in hexadecimal notation) are reserved for data identification purposes and consequently only 254 of the possible 256 words may be used to express a signal value.

The video data words are conveyed as a 27 Mwords/s multiplex in the following order:

$C_B, Y, C_R, Y, C_B, Y, C_R$ , etc.

where the word sequence  $C_B, Y, C_R$ , refers to co-sited luminance and colour-difference samples and the following word, Y, corresponds to the next luminance sample.

Rec. 656

2.3 Timing relationship between video data and the analogue synchronizing waveform

2.3.1 Line interval

The digital active line begins at 244 words (in the 525-line standard) or at 264 words (in the 625-line standard) after the leading edge of the analogue line synchronization pulse, this time being specified between half-amplitude points.

Figure 1 shows the timing relationship between video and the analogue line synchronization.

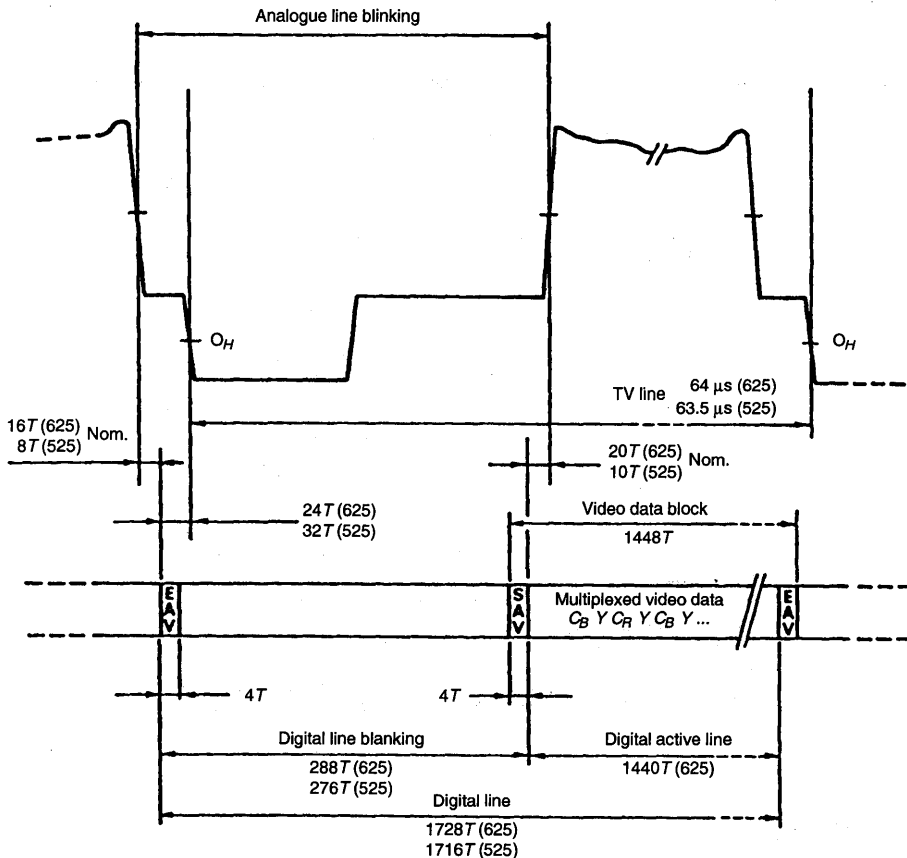

FIGURE 1 - Data format and timing relationship with the analogue video signal

T: clock period 37 ns nom.  
 SAV: start of active video timing reference code  
 EAV: end of active video timing reference code

## Rec. 656

2.3.2 *Field interval*

The start of the digital field is fixed by the position specified for the start of the digital line: the digital field starts 32 words (in the 525-line systems) and 24 words (in the 625-line systems) prior to the lines indicated in Table I.

2.4 *Video timing reference codes (SAV, EAV)*

There are two timing reference codes, one at the beginning of each video data block (Start of Active Video, SAV) and one at the end of each video data block (End of Active Video, EAV) as shown in Fig. 1.

Each timing reference code consists of a four word sequence in the following format: FF 00 00 XY. (Values are expressed in hexadecimal notation. Codes FF, 00 are reserved for use in timing reference codes.) The first three words are a fixed preamble. The fourth word contains information defining field 2 identification, the state of field blanking, and the state of line blanking. The assignment of bits within the timing reference code is shown below in Table II.

TABLE II — *Video timing reference codes*

Word	Bit No.							
	7 (MSB)	6	5	4	3	2	1	0 (MSB)
First	1	1	1	1	1	1	1	1
Second	0	0	0	0	0	0	0	0
Third	0	0	0	0	0	0	0	0
Fourth	1	F	V	H	P <sub>3</sub>	P <sub>2</sub>	P <sub>1</sub>	P <sub>0</sub>

F = 0 during field 1  
1 during field 2

V = 0 elsewhere  
1 during field blanking

H = 0 in SAV  
1 in EAV

P<sub>0</sub>, P<sub>1</sub>, P<sub>2</sub>, P<sub>3</sub>: protection bits (see Table III).

MSB: most significant bit

LSB: least significant bit

## Rec. 656

Table I defines the state of the V and F bits.

Bits  $P_0$ ,  $P_1$ ,  $P_2$ ,  $P_3$ , have states dependent on the states of the bits F, V and H as shown in Table III. At the receiver this arrangement permits one-bit errors to be corrected and two-bit errors to be detected.

TABLE III — Protection bits

Bit No.	7	6	5	4	3	2	1	0
Function	Fixed 1	F	V	H	$P_3$	$P_2$	$P_1$	$P_0$
0	1	0	0	0	0	0	0	0
1	1	0	0	1	1	1	0	1
2	1	0	1	0	1	0	1	1
3	1	0	1	1	0	1	1	0
4	1	1	0	0	0	1	1	1
5	1	1	0	1	1	0	1	0
6	1	1	1	0	1	1	0	0
7	1	1	1	1	0	0	0	1

## 2.5 Ancillary data

Provision is made for ancillary data to be inserted synchronously into the multiplex during the blanking intervals at a rate of 27 Mwords/s. Such data is conveyed by one or more 7-bit words, each with an additional parity bit (LSB) giving odd parity.

Each ancillary data block, when used, should be constructed as shown in Table IV from the timing reference code ANC and a data field.

## 2.6 Data words during blanking

The data words occurring during digital blanking intervals that are not used for the timing reference code ANC or for ancillary data are filled with the sequence 80, 10, 80, 10, etc. (values are expressed in hexadecimal notation) corresponding to the blanking level of the  $C_B$ , Y,  $C_R$ , Y signals respectively, appropriately placed in the multiplexed data.

Rec. 656

TABLE IV — Ancillary data block

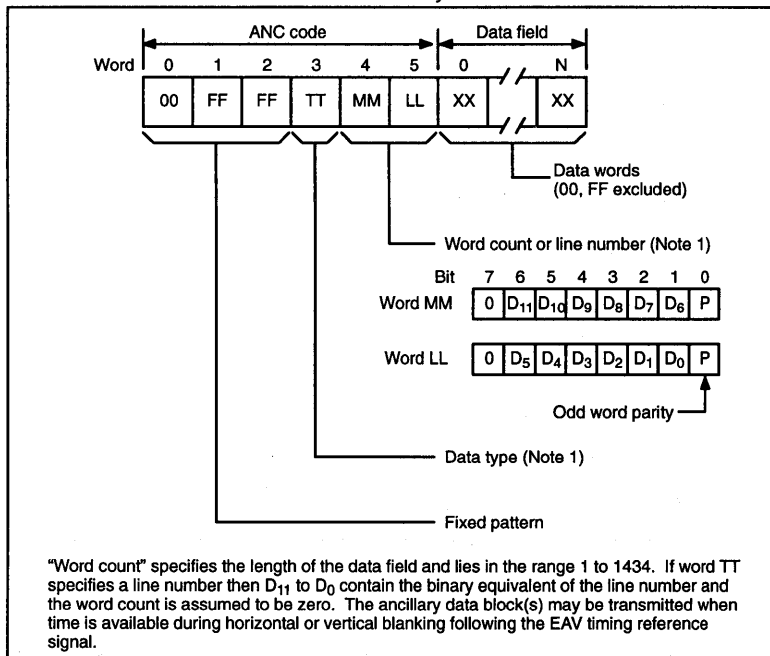

Note 1 — The precise location of the ancillary data blocks and the coding of words 3, 4 and 5 require further study.

PART II

BIT-PARALLEL INTERFACE

1. General description of the interface

The bits of the digital code words that describe the video signal are transmitted in parallel by means of eight conductor pairs, where each carries a multiplexed stream of bits (of the same significance) of each of the component signals, C<sub>B</sub>, Y, C<sub>R</sub>, Y. The eight pairs also carry ancillary data that is time-multiplexed into the data stream during video blanking intervals. A ninth pair provides a synchronous clock at 27MHz.

The signals on the interface are transmitted using balanced conductor pairs. Cable lengths of up to 50 m (≅ 160 feet) without equalization and up to 200 m (≅ 650 feet) with appropriate equalization (see § 6) may be employed.

The interconnection employs a twenty-five pin D-subminiature connector equipped with a locking mechanism (see § 5).

For convenience, the eight bits of the data word are assigned the names DATA 0 to DATA 7. The entire word is designated as DATA (0-7). DATA 7 is the most significant bit.

Video data is transmitted in NRZ form in real time (unbuffered) in blocks, each comprising one active television line.

2. Data signal format

The interface carries data in the form of 8 parallel data bits and a separate synchronous clock. Data is coded in NRZ form. The recommended data format is described in Part I.

## Rec. 656

## 3. Clock signal

## 3.1 General

The clock signal is a 27 MHz square wave where the 0-1 transition represents the data transfer time. This signal has the following characteristics:

Width:  $18.5 \pm 3$  ns

Jitter: Less than 3 ns from the average period over one field.

## 3.2 Clock-to-data timing relationship

The positive transition of the clock signal shall occur midway between data transitions as shown in Fig. 2.

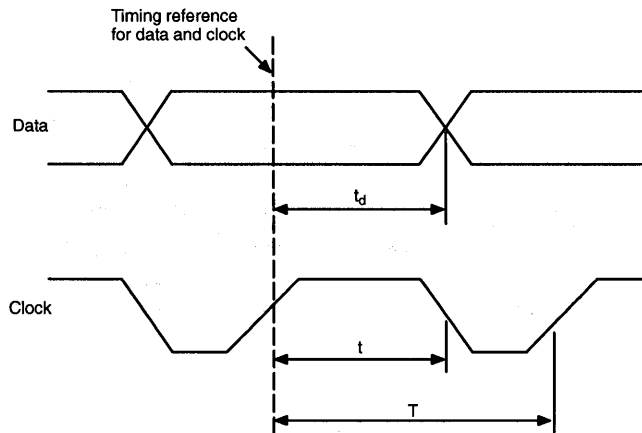

FIGURE 2 — Clock-to-data timing (at source)

Clock period (625):  $T = \frac{1}{1728 f_H} = 37 \text{ ns}$

Clock period (525):  $T = \frac{1}{1716 f_H} = 37 \text{ ns}$

Clock pulse width:  $t = 18.5 \pm 3 \text{ ns}$

Data timing – sending end:  $t_d = 18.5 \pm 3 \text{ ns}$

$f_H$ : line frequency

## 4. Electrical characteristics of the interface

## 4.1 General

The interface employs nine line drivers and nine line receivers.

Each line driver (source) has a balanced output and the corresponding line receiver (destination) a balanced input (see Fig. 3).

Although the use of ECL technology is not specified, the line driver and receiver must be ECL-compatible, i.e. they must permit the use of ECL for either drivers or receivers.

All digital signal time intervals are measured between the half-amplitude points.



## Rec. 656

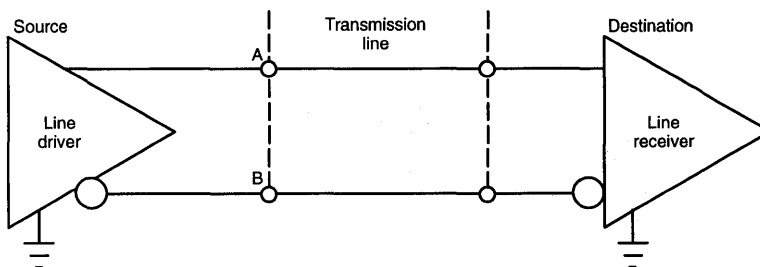

FIGURE 3 — Line driver and line receiver interconnection

## 4.2 Logic convention

The A terminal of the line driver is positive with respect to the B terminal for a binary 1 and a negative for a binary 0 (see Fig. 3).

## 4.3 Line driver characteristics (source)

4.3.1 *Output impedance:* 110  $\Omega$  maximum

4.3.2 *Common mode voltage:*  $-1.29 \text{ V} \pm 15\%$  (both terminals relative to ground).

4.3.3 *Signal amplitude:* 0.8 to 2.0 V peak-to-peak, measured across a 110  $\Omega$  resistive load.

4.3.4 *Rise and fall times:* less than 5 ns, measured between the 30% and 80% amplitude points, with a 110  $\Omega$  resistive load. The difference between rise and fall times must not exceed 2 ns.

## 4.4 Line receiver characteristics

4.4.1 *Input impedance:* 110  $\Omega \pm 10 \Omega$ .

4.4.2 *Maximum input signal:* 2.0 V peak-to-peak.

4.4.3 *Minimum input signal:* 185 mV peak-to-peak.

However, the line receiver must sense correctly the binary data when a random data signal produces the conditions represented by the eye diagram in Fig. 4 at the data detection point.

4.4.4 *Maximum common mode signal:*  $\pm 0.5 \text{ V}$ , comprising interference in the range 0 to 15 kHz (both terminals to ground).

4.4.5 *Differential delay:* Data must be correctly sensed when the clock-to-data differential delay is in the range between  $\pm 11 \text{ ns}$  (see Fig. 4).

## 5. Mechanical details of the connector

The interface uses the 25 contact type D subminiature connector specified in ISO Document 2110-1980, with contact assignment shown in Table V.

Connectors are locked together by a one-piece slide lock on the cable connectors and locking posts on the equipment connectors. Connectors employ pin contacts and equipment connectors employ socket contacts. Shielding of the interconnecting cable and its connectors must be employed (see Note).

*Note* — It should be noted that the ninth and eighteenth harmonics of the 13.5 MHz sampling frequency (nominal value) specified in Recommendation 601 fall at the 121.5 and 243 MHz aeronautical emergency channels. Appropriate precautions must therefore be taken in the design and operation of interfaces to ensure that no interference is caused at these frequencies. Emission levels for related equipment are given in CISPR Recommendation: "Information technology equipment — limits of interference and measuring methods" Document CISPR/B (Central Office) 16. Nevertheless, No. 964 of the Radio Regulations prohibits any harmful interference on the emergency frequencies.

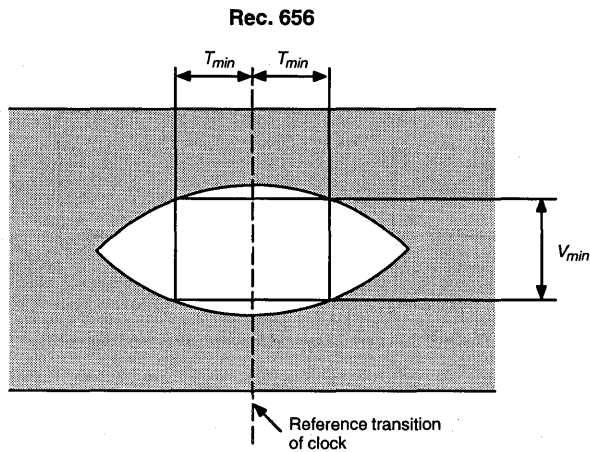

FIGURE 4 — Idealized eye diagram corresponding to the minimum input signal level

$$T_{min} = 11 \text{ ns}$$

$$V_{min} = 100 \text{ mV}$$

Note — The width of the window in the eye diagram, within which data must be correctly detected comprises  $\pm 3$  ns clock jitter,  $\pm 3$  ns data timing (see § 3.2), and  $\pm 5$  ns available for differences in delay between pairs of the cable.

TABLE V — Contact assignments

Contact	Signal line	Contact	Signal line
1	Clock A	14	Clock B
2	System ground	15	System ground
3	Data 7A (MSB)	16	Data 7B
4	Data 6A	17	Data 6B
5	Data 5A	18	Data 5B
6	Data 4A	19	Data 4B
7	Data 3A	20	Data 3B
8	Data 2A	21	Data 2B
9	Data 1A	22	Data 1B
10	Data 0A	23	Data 0B
11	Spare A-A	24	Spare A-B
12	Spare B-A	25	Spare B-B
13	Cable shield	—	—

**Rec. 656**

Any spare pairs connected to contacts 11,24 or 12,25 are reserved for bits of lower significance than those carried on contacts 10,23.

**6. Line receiver equalization**

To permit correct operation with longer interconnection links, the line receiver may incorporate equalization.

When equalization is used, it should conform to the nominal characteristics of Fig. 5. This characteristic permits operation with a range of cable lengths down to zero. The line receiver must satisfy the maximum input signal condition of § 4.4

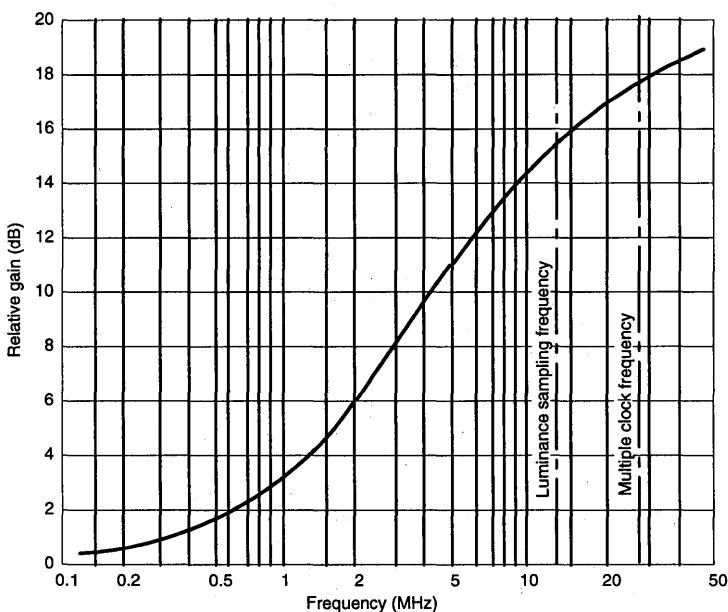

FIGURE 5 — Line receiver equalization characteristic for small signals

**PART III****BIT-SERIAL INTERFACE****1. General description of the interface**

The multiplexed data stream of 8-bit words (as described in Part I) is transmitted over a single channel in bit-serial form. Prior to transmission, additional coding takes place to provide spectral shaping, word synchronization and to facilitate clock recovery.

**2. Coding**

The 8-bit data words are encoded for transmission into 9-bit words as shown in Table VI.

For some 8-bit data words alternative 9-bit transmission words exist, as shown in columns 9B and 9B̄, each 9-bit word being the complement of the other. In such cases, the 9-bit word will be selected alternately from columns 9B and 9B̄ on each successive occasion that any such 8-bit word is conveyed. In the decoder, either word must be converted to the corresponding 8-bit data word.

RECOMMENDATIONS OF THE CCIR, 1990

CCIR 656

Rec. 656

TABLE VI — Encoding table

Input	Output	Input	Output	Input	Output	Input	Output	Input	Output	Input	Output	Input	Output
8B	9B 9B	8B	9B 9B	8B	9B 9B	8B	9B 9B	8B	9B 9B	8B	9B 9B	8B	9B 9B
00	0FE 101	2B	053	56	097	81	0AA	AC	12C	D7	0CC		
01	027	2C	1AC	57	168	82	055	AD	0D9	D8	139		
02	1D8	2D	057	58	099	83	1AA	AE	126	D9	0CE		
03	033	2E	1A8	59	166	84	0D5	AF	0E5	DA	133		
04	1CC	2F	059	5A	09B	85	12A	B0	11A	DB	0D8		
05	037	30	1A6	5B	164	86	095	B1	0E9	DC	131		
06	1CB	31	05B	5C	09D	87	16A	B2	116	DD	0DC		
07	039	32	05D	5D	162	88	0B5	B3	02E	DE	127		
08	1C6	33	1A4	5E	0A3	89	14A	B4	1D1	DF	0E2		
09	03B	34	065	5F	15C	8A	09A	B5	036	E0	123		
0A	1C4	35	19A	60	0A7	8B	165	B6	1C9	E1	0E4		
0B	03D	36	069	61	158	8C	0A6	B7	03A	E2	11D		
0C	1C2	37	196	62	025 1DA	8D	159	B8	1C5	E3	0E6		
0D	14D	38	026 1D9	63	0A1 15E	8E	0AC	B9	04E	E4	11B		
0E	0B4	39	08C 173	64	029 1D6	8F	153	BA	1B1	E5	0E8		
0F	14B	3A	02C 1D3	65	091 16E	90	0AE	BB	05C	E6	119		
10	1A2	3B	098 167	66	045 1BA	91	151	BC	1A3	E7	0EC		
11	0B6	3C	032 1CD	67	089 176	92	02A 1D5	BD	05E	E8	117		
12	149	3D	0BE 141	68	049 1B6	93	092 16D	BE	1A1	E9	0F2		
13	0BA	3E	034 1CB	69	085 17A	94	04A 1B5	BF	066	EA	113		
14	145	3F	0C2 13D	6A	051 1AE	95	094 16B	C0	199	EB	0F4		
15	0CA	40	046 1B9	6B	08A 175	96	0A8 157	C1	06C	EC	10D		
16	135	41	0C4 13B	6C	0A4 15B	97	0B7 148	C2	193	ED	076		
17	0D2	42	04C 1B3	6D	054 1AB	98	0F5 10A	C3	06E	EE	10B		
18	12D	43	0C8 137	6E	0A2 15D	99	0BB 144	C4	191	EF	0C7		
19	0D4	44	058 1A7	6F	052 1AD	9A	0ED 112	C5	072	F0	13C		
1A	129	45	0B1	70	056	9B	0BD 142	C6	18D	F1	047		
1B	0D6	46	14E	71	1A9	9C	0EB 114	C7	074	F2	1B8		
1C	125	47	0B3	72	05A	9D	0D7 128	C8	18B	F3	067		
1D	0DA	48	14C	73	1A5	9E	0DD 122	C9	07A	F4	19C		
1E	115	49	0B9	74	06A	9F	0DB 124	CA	189	F5	071		
1F	0EA	4A	06B	75	195	A0	146	CB	08E	F6	198		
20	0B2	4B	194	76	096	A1	0C5	CC	185	F7	073		
21	02B	4C	06D	77	169	A2	13A	CD	09C	F8	18E		
22	1D4	4D	192	78	0A9	A3	0C9	CE	171	F9	079		
23	02D	4E	075	79	156	A4	136	CF	09E	FA	18C		
24	1D2	4F	18A	7A	0AB	A5	0CB	D0	163	FB	087		
25	035	50	08B	7B	154	A6	134	D1	0B8	FC	186		
26	1CA	51	174	7C	0A5	A7	0CD	D2	161	FD	0C3		
27	04B	52	08D	7D	15A	A8	132	D3	0BC	FE	178		
28	1B4	53	172	7E	0AD	A9	0D1	D4	147	FF	062 19D		
29	04D	54	093	7F	152	AA	12E	D5	0C6				
2A	1B2	55	16C	80	155	AB	0D3	D6	143				

## Rec. 656

**3. Order of transmission**

The least significant bit of each 9-bit word shall be transmitted first.

**4. Logic convention**

The signal is conveyed in NRZ form. The voltage at the output terminal of the line driver shall increase on a transition from 0 to 1 (positive logic).

**5. Transmission medium**

The bit-serial data stream can be conveyed using either a coaxial cable (§ 6) or fibre optic bearer (§ 7).

**6. Characteristics of the electrical interface****6.1 Line driver characteristics (source)****6.1.1 Output impedance**

The line driver has an unbalanced output with a source impedance of 75  $\Omega$  and a return loss of at least 15 dB over a frequency range of 10 to 243 MHz.

**6.1.2 Signal impedance**

The peak-to-peak signal amplitude lies between 400 mV and 700 mV measured across a 75  $\Omega$  resistive load directly connected to the output terminals without any transmission line.

**6.1.3 DC offset**

The DC offset with reference to the mid amplitude point of the signal lies between +1.0V and -1.0 V.

**6.1.4 Rise and fall times**

The rise and fall times, determined between the 20% and 80% amplitude points and measured across a 75  $\Omega$  resistive load connected directly to the output terminals, shall lie between 0.75 and 1.5 ns and shall not differ by more than 0.40 ns.

**6.1.5 Jitter**

The timing of the rising edges of the data signal shall be within  $\pm 0.10$  ns of the average timing of rising edges, as determined over a period of one line.

**6.2 Line receiver characteristics (destination)****6.2.1 Terminating impedance**

The cable is terminated by 75  $\Omega$  with a return loss of at least 15 dB over a frequency range of 10 to 243 MHz.

**6.2.2 Receiver sensitivity**

The line receiver must sense correctly random binary data either when connected directly to a line driver operating at the extreme voltage limits permitted by § 6.1.2, or when connected via a cable having loss of 40 dB at 243 MHz and a loss characteristic of  $1/\sqrt{f}$ .

Over the range 0 to 12 dB no equalization adjustment is required; beyond this range adjustment is permitted.

**6.2.3 Interference rejection**

When connected directly to a line driver operating at the lower limit specified in § 6.1.2, the line receiver must correctly sense the binary data in the presence of a superimposed interfering signal at the following levels:

d.c.	$\pm 2.5$ V
Below 1 kHz:	2.5 V peak-to-peak
1 kHz to 5 MHz:	100 mV peak-to-peak
Above 5 MHz:	40 mV peak-to-peak

**Rec. 656****6.3 Cables and connectors****6.3.1 Cable**

It is recommended that the cable chosen should meet any relevant national standards on electro-magnetic radiation.

*Note* — It should be noted that the ninth and eighteenth harmonics of the 13.5 MHz sampling frequency (nominal value) specified in Recommendation 601 fall at the 121.5 and 243 MHz aeronautical emergency channels. Appropriate precautions must therefore be taken in the design and operation of interfaces to ensure that no interference is caused at these frequencies. Emission levels for related equipment are given in CISPR Recommendation: "Information technology equipment – limits of interference and measuring methods" (Document CISPR/B (Central Office) 16). Nevertheless, No. 964 of the Radio Regulations prohibits any harmful interference on the emergency frequencies.

**6.3.2 Characteristic impedance**

The cable used shall have a nominal characteristic impedance of 75  $\Omega$ .

**6.3.3 Connector characteristics**

The connector shall have mechanical characteristics conforming to the standard BNC type (IEC Publication 169-8), and its electrical characteristics should permit it to be used at frequencies up to 500 MHz in 75  $\Omega$  circuits.

**7. Characteristics**

To be defined.

## Color space, digital coding, and sampling schemes for video signals

There are various ways to represent video information. This note describes some aspects of different color spaces, conversion between them, and normalized digital coding.

### RGB at video camera output

The principal signal components of color camera or scanners, or other imaging pickup devices are Red, Green and Blue, RGB. These are also the principal components for video signal reproduction (i.e. picture display) at the monitor, as the CRT phosphors are comprised of these colors. But there is a non-linear relation between the camera signal pickup function (light input) and the CRT signal display function (light output). The transfer function is approximately exponential, and commonly referred to as "gamma" curve. Gamma is mainly a light reproduction function of the CRT.

$$\begin{aligned} R_{\text{display}} &= R_{\text{camera}}^{\gamma} \\ G_{\text{display}} &= G_{\text{camera}}^{\gamma} \\ B_{\text{display}} &= B_{\text{camera}}^{\gamma} \end{aligned}$$

During the development of the video transmission standards it was decided to compensate for this gamma-curve at the source side (camera, studio), and not to burden the television receiver with this effort and cost. The NTSC standard defines a gamma of 2.2, the PAL and SECAM standards defines a gamma of 2.8. Normally this gamma-correction is performed directly in the camera.

$$\begin{aligned} R_{\text{transmit}} &= R_{\text{pickup}}^{1/\gamma} \\ G_{\text{transmit}} &= G_{\text{pickup}}^{1/\gamma} \\ B_{\text{transmit}} &= B_{\text{pickup}}^{1/\gamma} \end{aligned}$$

The gamma-pre-corrected RGB signals at the camera output are stretched in the darker range and compressed in the lighter signal range. This has, as a side effect, a positive effect on noise influence on the transmission channel. The human eye is more sensitive to noise in dark areas, where the gamma behavior of the CRT reduces visibility.

Computer graphics generation is defined normally in "linear" RGB color space. The computer monitor of today has often a smaller gamma factor than used by the television standard definition, but there is no standard value. Sometimes it is compensated in the monitor itself, or by means of the look-up tables of the graphics RAMDAC, or not at all. The human eye is not very sensitive against gamma mismatch.

If video (camera) RGB gets merged with computer RGB, it is preferably be done in the same RGB space, including the assumed gamma. The anti-gamma compensation, as implemented in the Philips scaling ICs, compensates for a gamma-pre-correction of 1.4 only. The remaining gamma factor is assumed to be still performed by the computer monitor. A greater value of gamma-correction-compensation would lose more digital codes in the available 8-bit number range, and produce larger quantization steps in bright areas, which is not acceptable.

RGB can assume only positive values, and generate a cube like color space. The RGB components are commonly normalized to unity (e.g. 1 Volt peak-peak as analog signal). If any of the components is 0, it means there

is no color of this component, if it is 1, there is full (100%) saturation of this color. All components equal zero represents the color 'black', all components equal 1 represents bright 'white'. The RGB cube is an additive color space.

### Matrix to YUV (YCbCr)

In order to allow a compatible migration from black&white television to color television the YUV color space was utilized. Y stands for the luminance (lightness) information, and is compatible to black&white (and gray) signal. U and V are the so-called color difference signals B-Y and R-Y, and carry the additional color information (additive color space). The YUV representation of video information is also oriented on the human perception of visual information, whereby RGB representation is more based on the technical reproduction of color information. The human eye senses luminance and color with different receptors. There are less color receptors, and they have significant less spatial resolution. The YUV color space representation can take advantage of that fact, by spending less bandwidth for color difference information than for luminance information (see sampling schemes, later in this note).

Luminance Y can be positive only, the color difference signals U and V can be positive or negative. Commonly YUV is also normalized to unity (peak-to-peak = 1). The following matrix equation transforms gamma-pre-corrected and normalized RGB into normalized YUV (see also CCIR recommendation 601).

$$\begin{aligned} Y &= 0.299 * R + 0.587 * G + 0.114 * B \\ U = C_b = (B - Y) &= -0.169 * R - 0.331 * G + 0.500 * B \\ V = C_r = (R - Y) &= 0.500 * R - 0.419 * G - 0.081 * B \end{aligned}$$

(NOTE: For analog signal processing often un-normalized signals are used, which results in different number in the matrix equations, but does not change the cross relationship between RGB and YUV.)

# Color space, digital coding, and sampling schemes for video signals

U and V form a square color plane. But for colors of natural pictures and due to some restrictions in the video standards NTSC and PAL, this square color plane is reduced to a color circle plane. The vectors of natural colors don't point into the extreme corners of the square UV plane. The size of that circle is further restricted, if luminance values are close to minimum or maximum. There can't be any color in black or white e.g.. (Artificial YUV signals, e.g., test signals can use those extreme combinations). The YUV color space is best represented by a round column, with the dimension of luminance Y as axle in its center, and this round YUV color space column is shaped to a point at the bottom and at the top.

CCIR rec. 601 describes also how to represent these YUV signals by digital codes. It is recommended not to use the entire available number range for nominal signal values, but leaving some margin, room for digital signal processing, e.g. for over and under shoots. In an 8 bit system, luminance

Y black is coded with 16 decimal (= 10 hexadecimal), 100% white is coded with 235 decimal (= EB hexadecimal). The color difference signals Cb and Cr are coded in offset binary, which 'offsets' the 'no color' point into the middle of the number range to code 128 (80 hex). 100% color saturation uses the codes from 16 (10 hex) to 240 (F0 hex). 75% color saturation uses only codes from 44 (2C hex) to 212 (D4 hex) (see also data sheet SAA7151B, Fig.13, for example).

The codes 00 hex and FF hex should not be used for video signal coding. These two codes are reserved for synchronization purposes (see CCIR rec 656).

**(Note regarding nomenclature:** The terms "YUV" and "YCbCr" are referring to the same color space and cross relationship to RGB. The expressions "B-Y" and "R-Y" are normally used for non-normalized color difference signals. It is not part of any standard specification, but some literature is using the term "YUV" to indicate analog

signal representation, and the term "YCbCr" for its digital representation. Most data sheets and documents in this book are using both terms interchangeable for digital signal representation of normalized signals.)

The CCIR recommendation 601 (re-printed elsewhere in this book) gives an example of a digital RGB to YUV conversion. It is assuming digital sampled RGB, defined in codes like luminance signal Y, i.e., between 16 for black and 235 for full saturation. The given equation assumes a matrix realization by means of 8x8bit multipliers, which is only approximating the correct relationship. This equation system should not be used as reference to construct the inverse matrix from YUV to RGB. Today's technology allows matrix implementation by means of look-up tables, avoiding the limiting multiplier resolution and truncation problem.

The accurate digital RGB to digital YCrCb conversion is described by the following matrix:

$$\begin{bmatrix} Y \\ Cr \\ Cb \end{bmatrix} = \begin{bmatrix} 0.299 & 0.587 & 0.114 \\ \left( \frac{0.701}{2 \cdot 0.701} \right) * \left( \frac{224}{219} \right) & \left( \frac{0.587}{2 \cdot 0.701} \right) * \left( \frac{224}{219} \right) & \left( \frac{0.114}{2 \cdot 0.701} \right) * \left( \frac{224}{219} \right) \\ \left( \frac{0.299}{2 \cdot 0.886} \right) * \left( \frac{224}{219} \right) & \left( \frac{0.587}{2 \cdot 0.886} \right) * \left( \frac{224}{219} \right) & \left( \frac{0.886}{2 \cdot 0.886} \right) * \left( \frac{224}{219} \right) \end{bmatrix} * \begin{bmatrix} R \\ G \\ B \end{bmatrix}$$

The digital RGB ranges from 16 to 235, i.e. over 219 possible values. The digital CrCb goes from 16 to 240, uses 224 possible values. This causes a re-normalization factors.

The inverse matrix from digital YCrCb to digital RGB (16 to 235) calculates to :

$$\begin{bmatrix} R \\ G \\ B \end{bmatrix} = \begin{bmatrix} 1 & 1.371 & 0 \\ 1 & -0.698 & -0.336 \\ 1 & 0 & 1.732 \end{bmatrix} * \begin{bmatrix} Y \\ Cr \\ Cb \end{bmatrix}$$



# Color space, digital coding, and sampling schemes for video signals

## YIQ, and other YUV related color spaces

YIQ color space is similar to YUV color space except that it has the I and Q color axes rotated 33 degrees with the respect to the U and V axes of the YUV definition.. "I" means "in phase", and "Q" means "quadrature phase". This color space was adopted by early NTSC systems to take full advantage of the human eye color response with respect to color bandwidth capability.

$$I = V * \cos(33^\circ) - U * \sin(33^\circ)$$

$$Q = V * \sin(33^\circ) + U * \cos(33^\circ)$$

The Philips digital decoder have fully adjustable "hue" control. The demodulation angle can be programmed to any value, and can achieve an I-Q demodulation, i.e., generating I and Q outputs instead of U and V.

Some other color space approaches (like HSI, or HSV, or HSL etc.) describe the UV plane in polar coordinates by means of a vector, its length(S = saturation) and its angle(H = hue). The luminance (Intensity, Value, Lightness) corresponds to the Y of

YUV space. This color space representations are related to the quadrature encoding of U and V onto a color subcarrier, in the transmission standards NTSC and PAL.

## CMYK for color printer

CMYK color space is a subtractive color space used for color printing. CMYK stands for Cyan, Magenta, Yellow and Black. It describes, which color component is removed from white, to generate a certain wanted/printed color. In theory, only the CMY portion is required, however, in actual printing ink applications, black ink is added to enhance the contrast ratio and purity of the black portion of the image. K is defined as min(CMY), that is, K is equal the lowest value of C, M, or Y.

The relation of CMY to RGB is given vectorally as :

$$\begin{bmatrix} C \\ M \\ Y \end{bmatrix} = \begin{bmatrix} 1 \\ 1 \\ 1 \end{bmatrix} - \begin{bmatrix} R \\ G \\ B \end{bmatrix}$$

## 4:4:4 sampling (RGB, YCbCr)

Figure 1 illustrates the sampling positions for 4:4:4 sampling, which is mainly used for

RGB, but can also be used for YUV or YCbCr. At each pixel a sample is taken for R, G, and B, or Y, U, and V etc.

All three components have the same spatial resolution (bandwidth). If 8 bits per component is used, a 24 bit system is required.

## 4:2:2 YCbCr sampling

Figure 2 represents a more effective sampling format, in which Y samples are measured at each pixel position, and Cb and Cr samples only at every second pixel position. By that the color information has horizontally a resolution, that is half of that of luminance. The human eye does not perceive chrominance with the same clarity as luminance, therefore this type of data reduction causes very little visual loss of content. The 4:2:2 sampling scheme reduces the data bandwidth need by a third.

Cb and CR samples are co-sited with every second Y samples, but starting with the first Y sample of each line. If 8 bits per component is used, a 16 bit system is required.

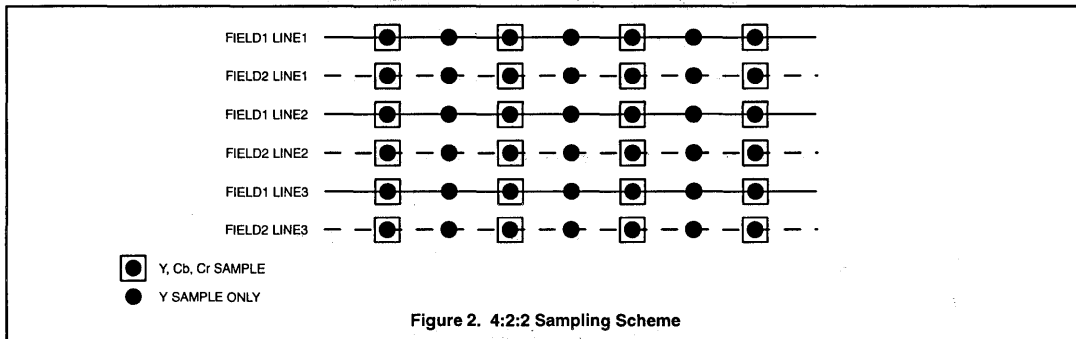
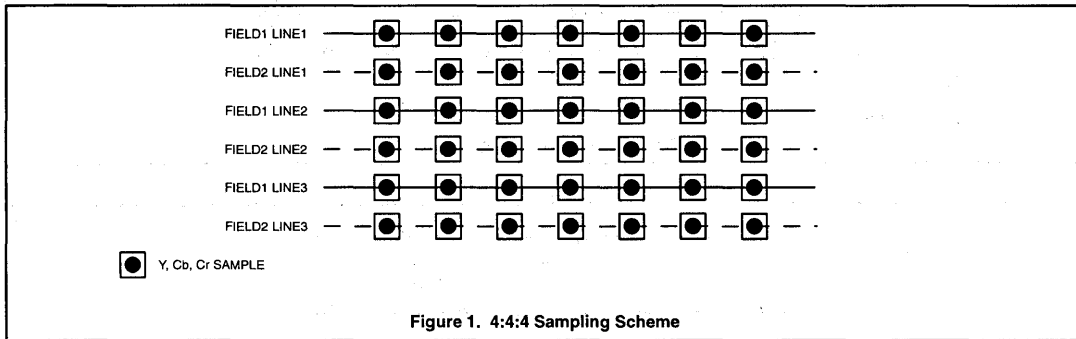

# Color space, digital coding, and sampling schemes for video signals

## 4:1:1 YCbCr (orthogonal) sampling

Figure 3 is an example of 4:1:1 sampling, often used in consumer type video products. The achievable color bandwidth in this case is only one third that of luminance. But in broadcasted video (NTSC, PAL, or SECAM), or in tape-recorded video, there is normally not more chroma bandwidth supported/available.

The CbCr samples are taken co-sited with every fourth luminance pixel, but starting with the first luminance sample of each line. An 8 bit per component system is capable of fitting into a 12 bit wide frame buffer. 7 bit per component and 6 bit per component systems are also used in combination with 4:1:1 sampling, which reduces the needed frame buffer capacity even more (e.g., for PIP function on television sets).

## 4:2:0 YCbCr (spatial) sampling

This sampling scheme is used generally for MPEG and H-261 compression standards, and is also called "coded picture sampling". Figure 4 shows the two dimensional 2:1 sub-sampling of color pixels relative to luminance pixels. The CbCr samples are not co-sited with a luminance sample, but representing the color information for a quartet of four Y pixels, ordered in a square. The CbCr values are normally derived (calculated) from a 4:4:4 or 4:2:2 sampling scheme by both horizontal and vertical filtering and interpolation. Usually the CbCr values are transported only every second scan line with pairs of Y samples, the other line carries only Y samples (4:2:0). The overall data bandwidth of 4:2:0 sampling is identical to 4:1:1 sampling.

In the example in Figure 4 a non-interlaced video source is represented, as those compression standards know only 'pictures' and use whole frames, or just one field.

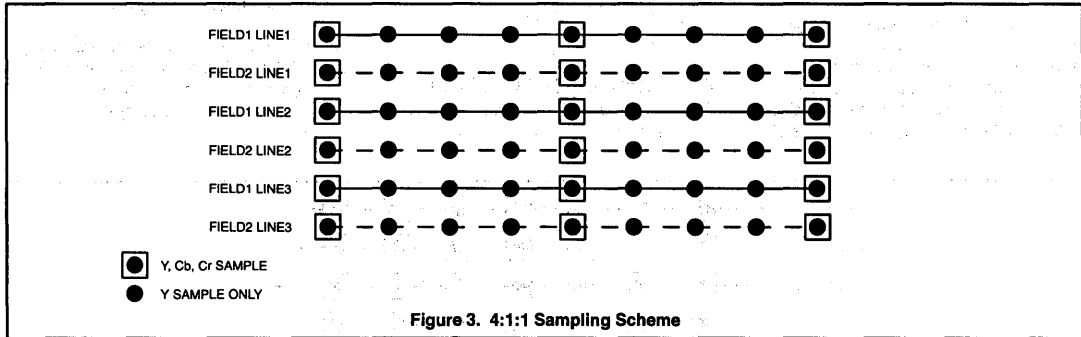

Figure 3. 4:1:1 Sampling Scheme

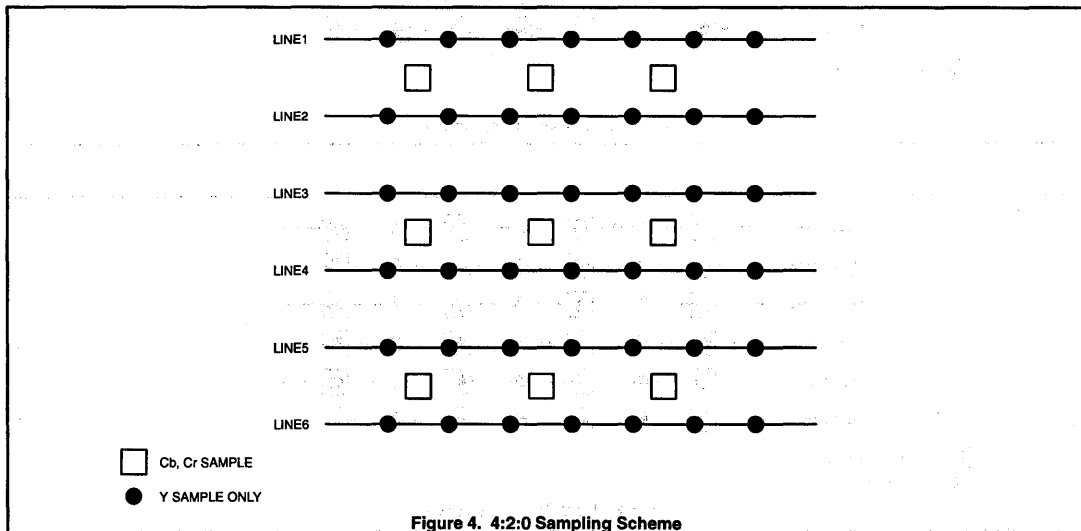

Figure 4. 4:2:0 Sampling Scheme

## Video signal bandwidth/resolution

### BANDWIDTHS OF VARIOUS VIDEO SIGNALS

FORMAT	FORMAT RESOLUTION		BANDWIDTH	BANDWIDTH
	TOTAL RESOLUTION	ACTIVE RESOLUTION	MBytes/sec (burst) <sup>1</sup>	MBytes/sec (continuous) <sup>2</sup>
<b>CCIR 601 (30 Frames per Second, 4:3 Aspect Ratio)</b>				
QCIF	214 × 131	176 × 120	1.68	1.27
CIF	429 × 262	352 × 240	6.74	5.07
Full resolution	858 × 525	720 × 485	27.0	20.95
<b>CCIR 601 (25 Frames per Second, 4:3 Aspect Ratio)</b>				
QCIF	216 × 156	176 × 144	1.69	1.27
CIF	432 × 312	352 × 288	6.74	5.07
Full resolution	864 × 625	720 × 576	27.0	20.74
<b>Square Pixel (30 Frames per Second, 1:1 Aspect Ratio)</b>				
QCIF	195 × 131	160 × 120	1.53	1.15
CIF	390 × 262	320 × 240	6.13	4.61
Full resolution	780 × 525	640 × 480	24.55	18.43
<b>Square Pixel (25 Frames per Second, 1:1 Aspect Ratio)</b>				
QCIF	236 × 156	192 × 144	1.84	1.38
CIF	472 × 312	384 × 288	7.36	5.53
Full resolution	944 × 625	768 × 576	29.5	22.12

**NOTE:**

1. Burst bandwidth assumes that the transfer of video occurs only during the active period.
2. Continuous bandwidth assumes entire frame time is used to transfer active video.

Data rates given here are for 16-bit 4:2:2 Y<sub>C</sub>R<sub>B</sub> video; if 24-bit RGB is used, the rates are 150% higher.



## International TV systems and standards

Country	standard for			Country	standard for		
	VHF	UHF	colour		VHF	UHF	colour
<b>A</b>				<b>F</b>			
Afganistan	B		PAL	Finland	B	G	PAL
Albania	B			France	E	L	SECAM
Algeria	B	G,H	PAL	French Polynesia	K1		
Angola	I			<b>G</b>			
Argentina	N	N	PAL	Gabon	K1		SECAM
Australia	B	G	PAL	Gambia	(K1)		
Austria	B	G	PAL	German Dem. Rep.	B	G	SECAM
Azores	M			German Fed. Rep.	B	G	PAL
<b>B</b>				Ghana	B		PAL
Bahamas	M		NTSC	Gibraltar	B		PAL
Bahrain	B		PAL	Greece	B	G	SECAM
Bangla-Desh	B			Greenland	M/B		NTSC/ PAL
Barbados	N		NTSC	Guadeloupe	K1		SECAM
Belgium	B	H	PAL	Guatemala	M	M	NTSC
Bermuda	M		NTSC	Guana (French)	K1		
Bolivia	N		NTSC	<b>H</b>			
Brazil	M	M	PAL	Haiti	M	M	NTSC
Brunei	B		PAL	Honduras	M	M	NTSC
Bulgaria	D	K	SECAM	Hong Kong	B	I	PAL
Burma			NTSC	Hungary	D	K	SECAM
<b>C</b>				<b>I</b>			
Cambodia	M			Iceland	B		PAL
Canada	M	M	NTSC	India	B		
Canary Isl.	B		PAL	Indonesia	B	G	PAL
Centr. Afr. Rep.	B			Iran	B		SECAM
Chad	K1			Iraq	B		SECAM
Chile	M	M	NTSC	Ireland	A,I	I	PAL
China	D	K	PAL	Israel	B	G	PAL
Colombia	M	M	NTSC	Italy	B	G	PAL
Congo	D			Ivory Coast	K1		SECAM
Costa Rica	M	M	NTSC	<b>J</b>			
Cuba	M	M	NTSC	Jamaica	M		-
Cyprus	B	G,H	PAL	Japan	M	M	NTSC
Czechoslovakia	D	K	SECAM	Jordan	B		PAL
<b>D</b>				<b>K</b>			
Dahomey	K1	K1*		Kenya	B		PAL
Denmark	B	G	PAL	Korea, North	D		SECAM
Djibouti	K1		SECAM	Korea, South	M	M	NTSC
Dominican Rep.	M	M	NTSC	Kuwait	B		PAL
<b>E</b>							
Ecuador	M	M	NTSC				
Egypt	B	G,H	SECAM				
El Salvador	M	M	NTSC				
Equatorial Guinea	B		PAL				
Ethopia	B						

# International TV systems and standards

Country	standard for			Country	standard for		
	VHF	UHF	colour		VHF	UHF	colour
<b>L</b>				<b>R</b>			
Lebanon	B		SECAM	Reunion	K1		SECAM
Liberia	B		PAL	Rumania	D	D	I
Libya	B		SECAM	<b>S</b>			
Luxembourg	C	G,L	PAL/ SECAM	Sabah/Sarawak	B		PAL
<b>M</b>				St. Kitts	M	M	NTSC
Madagascar	K1			Samoa	M		NTSC
Madeira	B		PAL	Saudi Arabia	B	G	SECAM
Malagasy	K1		SECAM	Senegal	K1		
Malawi	B	G*		Sierra Leone	B		PAL
Malaysia	B		PAL	Singapore	B		PAL
Mali	K1	K1*		South Africa	I	I	PAL
Malta	B	H	PAL	Spain	B	G	PAL
Martinique	K1		SECAM	Sri Lanka	B		PAL
Marutania	B			Sudan	B		
Marutius	B		SECAM	Surinam	M	M	NTSC
Mexico	M	M	NTSC	Swaziland	B	G	PAL
Monaco	E	G,L	PAL/ SECAM	Sweden	B	G	PAL
Mongolia	D			Switzerland	B	G	PAL
Morocco	B		SECAM	Syria	B		SECAM
Mozambique	B			<b>T</b>			
<b>N</b>				Tahiti	K1		
Netherlands	B	G	PAL	Taiwan	M	M	NTSC
Neth. Antilles	M	M	NTSC	Tanzania (Zanzibar)	B	B	PAL
New Caledonia	K1		SECAM	Thailand	B	M	PAL
New Zealand	B		PAL	Togo Rep.	K1		SECAM
Nicaragua	M	M	NTSC	Trinidad & Tobago	M	M	NTSC
Niger	K1		SECAM	Tunisia	B		SECAM
Nigeria	B		PAL	Turkey	B		(PAL)
Norway	B	G	PAL	<b>U</b>			
<b>O</b>				Uganda	B		PAL
Oman	B	G	PAL	United Arab Emirates	B	G	PAL
<b>P</b>				United Kingdom	A	I	PAL
Pakistan	B		PAL	Upper Volta	K1		
Panama	M	M	NTSC	Uruguay	N	N	PAL
Paraguay	N		PAL	USA	M	M	NTSC
Peru	M	M	NTSC	USSR	D	K	SECAM
Philippines	M	M	NTSC				
Poland	D	K	SECAM				
Portugal	B	G	PAL				
Puerto Rico	M	M	NTSC				
<b>Q</b>							
Qatar	B		PAL				

# International TV systems and standards

Country	standard for		
	VHF	UHF	colour
<b>V</b>			
Venezuela	M	M	NTSC
Vietnam (Khmer)	M		NTSC
<b>Y</b>			
Yemen (Arab Rep.)	B		PAL
Yemen (Dem. Rep.)	B		
Yugoslavia	B	H	PAL
<b>Z</b>			
Zaire	K1		SECAM
Zambia	B		PAL
Zimbabwe	B		

\* Estimated

( ) There is no local broadcast station,  
but one can listen to a broadcast  
from a neighbouring country.

- There is no broadcast.

# International TV systems and standards

## BASIC CHARACTERISTICS OF VIDEO AND SYNCHRONIZING SIGNALS

Characteristics	CCIR system designation										
	A	M	N	C	B,G	H	I	D,K	K1	L	E
Number of lines per frame	405	525	625	625	625	625	625	625	625	625	819
Number of fields per second	50	60 (59.94)	50	50	50	50	50	50	50	50	50
Line frequency $f_L$ , Hz, and tolerances	10,125	15,750 15,734 ( $\pm 0.0003\%$ )	15,625 $\pm 0.15\%$	15,625 $\pm 0.02\%$	15,625 $\pm 0.02\%$ ( $\pm 0.0001\%$ )	15,625 $\pm 0.02\%$ ( $\pm 0.0001\%$ )	15,625 $\pm 0.0001\%$	15,625 $\pm 0.02\%$ ( $\pm 0.0001\%$ )	15,625 $\pm 0.02\%$ ( $\pm 0.0001\%$ )	15,625 $\pm 0.02\%$ ( $\pm 0.0001\%$ )	20,475
Interlace ratio	2/1	2/1	2/1	2/1	2/1	2/1	2/1	2/1	2/1	2/1	2/1
Aspect ratio	4/3	4/3	4/3	4/3	4/3	4/3	4/3	4/3	4/3	4/3	4/3
Blanking level, IRE units	0	0	0	0	0	0	0	0	0	0	0
Peak-white level	100	100	100	100	100	100	100	100	100	100	100
Sync-pulse level	-43	-40	-40	-43	-43	-43	-43	-43	-43	-43	-43
Picture-black level to blanking level (setup)	0	7.5 $\pm 2.5$	7.5 $\pm 2.5$	0	0	0	0	0-7	0 color 0-7 mono	0 color 0-7 mono	0-5
Nominal video bandwidth, MHz	3	4.2	4.2	5	5	5	5.5	6	6	6	10
Assumed display gamma	2.8	2.2	2.2	2.8	2.8	2.8	2.8	2.8	2.8	2.8	2.8

Notes: (1) Systems A, C, and E are not recommended by CCIR for adoption by countries setting up a new television service. (2) Values of horizontal line rate tolerances in parentheses are for color television. (3) In the systems using an assumed display gamma of 2.8, an overall system of gamma of 1.2 is assumed. All other systems assumed an overall transfer function of unity.

## CCIR COLOR SYSTEMS CHARACTERISTICS (II)

Item	M/NTSC	M/PAL	B,G,H,PAL	I/PAL	B,D,G,H,K,K1,L/SECAM
Subcarrier frequency, MHz	3.579545 $\pm$ 10	3.575611.49 $\pm$ 10	4.433618.75 $\pm$ 5	4.433618.75 $\pm$ 1	$f_{OR} = 4.406250 \pm 2000$ $f_{OB} = 4.250000 \pm 2000$
$f_{SC}$ multiple of $f_H$	$f_{SC} = \frac{455}{2} f_H$	$f_{SC} = \frac{909}{4} f_H$	$f_{SC} = \frac{1135}{4} + \frac{1}{25} f_H$		$f_{OR} = 282 f_H$ $f_{OB} = 272 f_H$





## Video glossary

### DEFINITION OF TERMS

**AC-COUPLED** – A means by which the constant, or DC component, of a signal is removed, usually by passing the signal through a capacitor.

**AM** – Amplitude Modulation (AM) is a modulation process by which the amplitude of the carrier signal is scaled in proportion to the modulation signal (which is the signal which carries the content). AM modulation is used for the video portion of the transmitted TV signal for both NTSC and PAL standards.

**Anti-Top Flutter Pulse** – Disables the phase detector during equalization and framing times.

**APL** – Average Picture Level. The mean or average signal level during the active video period. It is expressed as a percentage of the difference between blanking and peak white (0 and 100 IRE).

**AV** – Audio Video

**Back Porch** – That section of the video waveform between the end of horizontal sync and the beginning of active video. The color burst signal is inserted during this period.

**Bandwidth** – The frequency range over which an input signal of uniform amplitude will be passed with uniform output (within a specified limit).

**Baseband Video** – Same as Composite Video (CVS or CVBS)

**Black Burst** – Black Burst (Color Black) is a composite video signal containing sync information, color reference (burst) and setup information (in the case of NTSC). Black Burst is often used as the studio reference to facilitate synchronization of all the devices in the system.

**Black Level** – The signal level which represents black picture intensity. For NTSC, this level is 7.5 IRE (also called Setup) and for PAL this level is 0 IRE.

**Black Level Noise** – Very similar to a white spot noise spike except it is in the opposite or black level direction.

**Blanking Level** – The video level immediately preceding or following horizontal sync exclusive of the active video region. The video level for blanking is defined as 0 IRE. In the case of PAL, blanking level and black level are the same.

**Breezeway** – That portion of the Back Porch between the end of horizontal sync and the beginning of the color burst.

**Color Difference Signals** – The chrominance information of a video signal, expressed as the combination of two orthogonal axis signals, B-Y (also called U or Cb) and R-Y (also called V or Cr). These signals contain no luminance (Y) information.

**Composite Video** – Composite video (CVS/CVBS) signal carries video picture information for color, brightness and synchronizing signals for both horizontal and vertical scans. Sometimes referred to as "Baseband Video".

**CTV** – Color Television

**CVBS or CVS** – Same as composite video.

**Data Slicing** – The process of extracting digital data from an incoming, non-TTL signal.

**DC Coupled** – An electrical connection passing both the DC component as well as the AC component of a signal.

**DC Restoration** – The process of setting the DC level of a video signal to a defined level. DC restoration is generally applied during the back porch region of the video signal by means of a clamp pulse applied to the restoration circuit at that point of the signal.

**Demodulation** – The process by which the original signal content is recovered from the modulated carrier. In color television, demodulation may additionally refer to the recovery of the color difference signals from the modulated chroma subcarrier.

**Equalization Pulses** – The pulses existing before and after the vertical pulse during the vertical interval. These are half horizontal in length and are inserted to effect the half-line offset in vertical sync required for interlace.

**Field** – For interlaced video the total picture is divided into two fields, one even and one odd each containing one half of the total vertical information. Each field takes one sixtieth of a second (one fiftieth for PAL) to complete. Two fields make a complete frame of video.

**FM** – Frequency modulation is the method by which the modulation signal which contains the information is used to vary the frequency of the carrier. For NTSC and PAL video, FM modulation is used to transmit the sound portion of the program.

**Frame** – One frame (two fields) of video contains the full vertical interlaced information content of the picture. For NTSC this consists of 525 lines and for PAL a frame is consisted of 625 lines.

**Front Porch** – The section of the video signal that lies between the end of active video and the beginning or leading edge of horizontal sync.

**Full Field Teletext** – In this mode, Teletext information is transmitted over, virtually, all available TV lines.

**Gamma** – Cathode ray tubes (CRTs) do not have a linear relationship between brightness and the input voltage applied. To compensate for this non-linearity, a pre distortion or gamma correction is applied, generally at the camera source. A value of gamma equal to 2.2 is typical, but can vary for different CRT phosphors.

**Genlock** – Two composite video signals can be phase locked to each other by synchronizing both the composite sync and color burst of the two signals. This process is called genlock.

**Ghost Rows** – These are the rows that are specified by the "row address field" of the "page header" but do not get displayed. These are rows 24 to 31. Sometimes referred to as "Extension Packets", these rows carry miscellaneous control information. (Page extension for Telesoftware, linked pages, higher display level, etc.)

**Harmonic Distortion** – A distortion added to a signal which consists of multiples or harmonics of that signal which were not present in the original. System non-linearity can contribute to this distortion.

**Horizontal Blanking** – The sum of the front porch, horizontal sync and back porch periods, i.e. the entire period from the end of active video to the beginning of active video on a line.

**Horizontal Sync** – A negative active pulse of 287mv amplitude (300mv for PAL) inserted in the composite video signal. This pulse is extracted by the monitor (or receiving system) and used to horizontally synchronize or define the left hand side of the image.

**Hue** – Tint or color such as red, pink, yellow, etc.

**Hum** – An undesirable superimposition of 60Hz (50Hz in Europe) power energy into the signal content.

**Intercarrier Sound** – The means by which sound is separated from the modulated television signal by the use of a sound carrier to beat against the video carrier. This produces a 4.5MHz signal which contains the audio portion of the television signal.

**Interlace** – A method to give a higher apparent number of lines on the television CRT screen. One television frame is written on the CRT with television lines of the "even field" placed in between those of the "odd field".

## Video glossary

**IQ Signals** – Similar to the color difference signals (R-Y), (B-Y) but using different vector axis for encoding or decoding. Used by some USA TV and IC manufacturers for color decoding.

**IRE** – 1/140 of a volt which is the peak to peak amplitude of a video signal from the bottom of sync to the top of peak white. Sync and burst amplitude is defined as 40 IRE units, while active video is 100 IRE Max. The unit was originally defined by the Institute of Radio Engineers, hence the name.

**Linear Distortion** – Distortions which are independent of amplitude.

**Luminance** – The brightness or black and white content of a picture. No hue or saturation components exist. Luminance is also referred to by the letter Y and is defined as a sum of scaled red, green and blue primaries by the formula:  

$$Y = .30R + .59G + .11B.$$

**Modulation** – The process whereby a signal containing information is used to vary some characteristic of a carrier. In the case of AM the carrier amplitude is varied, in the case of FM the carrier frequency is varied and in the case of chroma modulation, the phase of the carrier (called subcarrier in this case) is modulated.

**NABTS** – North American Broadcasting Teletext Specifications. *Note that this is not a standard.*

This document specifies both the acquisition protocol and the display format. The display format is NAPLPS.

**NAPLPS** – North American Presentation Level Protocol Syntax. Again, this is not a display standard. It applies to both Teletext and Videotex services.

**Non-Linear Distortion** – These are distortions which are amplitude dependent. Differential gain and phase measurements are used to measure these distortions.

**NTSC** – National Television Standards Committee (USA).

**Page Header** – This is equivalent to Row 0. Carry Control information about this page.

**PAL** – Phase Alternate Line. A television standard used in Europe and other countries which alternates the relationship of the color axes on a line by line basis so that color modulation errors can be canceled out.

**Peak White** – Maximum amplitude signal corresponding to the maximum brightness of the video screen.

**Peritel** – An audio/video connector standard for European TV receivers. Serves the same purpose as AV connector on some of the newer American TV sets.

**Quadrature AM** – Refers to the process by which two different modulation signals each modulate carriers of the same frequency but which are 90 degrees out of phase. The summed signals can be added together for transmission and can be recovered at the receiver end if they are demodulated 90 degrees apart. This is the process used to modulate chrominance information onto the color subcarrier of a video signal.

**Quadrature Distortion** – Distortion which results if the sidebands of a vestigial sideband transmission are uneven or asymmetrical. If synchronous decoding is used instead of envelope detection, this distortion can be minimized.

**RF Video** – System used on standard Television transmissions via an antenna or cable system. Baseband video is amplitude modulated on an RF carrier.

**RGB** – Three separate signals of Red, Green and Blue used to produce a color image.

**R-Y, G-Y, B-Y** – Red, Green or Blue signals without the luminance (-Y).

**Sandcastle Pulse** – Multilevel pulse generated by the horizontal processor and the vertical deflection circuit. This pulse contains gating pulse and blanking signal information for use by the color decoder and the video control circuits.

**Saturation** – A characteristic describing color amplitude or intensity. A color of a given hue may consist of low or high saturation value which relates to the vividness of the color.

**SECAM** – Sequential Color and Memory system. TV color system used primarily in France and the USSR.

**Setup** – A video level which, for NTSC, defines black level and which is 7.5 IRE above blanking. Pal does not have setup.

**SRM** – Service Reference Model of NAPLPS. It is a skeleton NAPLPS, specifying a low level type display in order to allow for easy implementation (256h x 200v pixels).

**Subcarrier** – The carrier used to convey chroma information within the composite video signal. The R-Y and B-Y color difference signals are modulated onto the subcarrier by a process of quadrature AM modulation. The frequency of the subcarrier signal is related to the odd half-line multiples of the horizontal frequency in such a manner as to allow the chrominance frequency spectrum to co-exist or interleave within the luminance spectrum.

**Synchronous Detection** – A process by which demodulation is performed by multiplying the signal by another signal generated by an oscillator which is locked to the original carrier. This is the method preferred over envelope detection.

**Teletext** – One way broadcast of digital information.

**Termination** – Unless proper source and termination impedance's are presented to a transmission line, such as a co-ax cable, undesirable reflections and ringing can occur. Video transmission cable typically has a characteristic impedance of 75 ohms and should be terminated by same.

**Unmodulated** – Refers to the pure carrier frequency with no AM, FM, or Phase modulation imposed upon it. Also referred to as CW or continuous wave.

**Vectorscope** – An oscilloscope specifically designed to demodulate and display chroma as an x-y display of the decoded color with respect to the R-Y and B-Y (or I and Q) axis. Hue is displayed as the angle around the display, and saturation as the amount of displacement from the center.

**Vertical Blanking Interval (VBI)** – The time it takes the beam to fly back to the top of the screen in order to retrace the opposite field (odd or even). VBI is in the order of 20 TV (25 for PAL) lines. Teletext information is transmitted over 4 of these lines (lines 14-17).

**Videotex** – A two-way interactive system through which the user can communicate to a large, organized and secure, database through a telephone line using the TV as the display medium.

**Waveform Monitor** – An oscilloscope designed to measure the specific timings of a video signal.

**World System Teletext (WST)** – World System Teletext is based on the British teletext standard in which a one-to-one correspondence exists between transmitted characters, page memory, word addresses and the display screen character locations. Over 98% of the world's teletext decoders are WST compatible.

**Y Signal** – Luminance. Determines the brightness of each spot (pixel) on CRT screen either color or B/W systems, but not the color.

## Alphanumeric index of products

Analog-to-digital converter selection guide .....	3-3
Digital-to-analog converter selection guide .....	3-4
PCF8574/PCF8574A Remote 8-bit I/O expander for I <sup>2</sup> C-bus .....	3-5
PCF8584 I <sup>2</sup> C-bus controller .....	3-16
SAA1101 Universal sync generator (USG) .....	3-41
SAA5191 Teletext video processor .....	3-52
SAA5231 Teletext video processor .....	3-58
SAA5250 Interface for data acquisition and control (for multi-standard teletext systems) .....	3-69
SAA5252 Line twenty-one acquisition and display (LITOD) .....	3-100
SAA5296 Single chip economy 10 page teletext/TV microcontroller .....	3-114
SAA7110 One Chip Frontend 1 (OFC1) .....	3-120
SAA7116 Digital video to PCI interface .....	3-185
SAA7151B Digital multistandard colour decoder with SCART interface (DMSD2-SCART) .....	3-202
SAA7152 Digital video comb filter (DCF) .....	3-243
SAA7157 Clock signal generator circuit for digital TV systems (SCGC) .....	3-252
SAA7164 Video enhancement and D/A processor (VEDA3) .....	3-258
SAA7165 Video enhancement and D/A processor (VEDA2) .....	3-276
SAA7169 35 MHz triple 9-bit D/A converter for high-speed video .....	3-295
SAA7183 Digital video encoder (square pixel with Macrovision) .....	3-302
SAA7186 Digital video scaler .....	3-303
SAA7187 Digital video encoder (DENC2-SQ) .....	3-332
SAA7188A Digital video encoder (DENC2-M) .....	3-359
SAA7191B Digital multistandard colour decoder, square pixel (DMSD-SQP) .....	3-387
SAA7192A Digital colour space converter .....	3-418
SAA7194 Digital video decoder and scaler circuit (DESC) .....	3-454
SAA7196 Digital video decoder, scaler, and clock generator (DESCPro) .....	3-457
SAA7197 Clock signal generator circuit for Desktop Video systems (SCGC) .....	3-511
SAA7199B Digital video encoder, GENLOCK-capable .....	3-517
SAA9042 Multi-standard Teletext IC for standard and features TV .....	3-549
SAA9051 Digital multistandard TV decoder .....	3-575
SAA9057B Clock signal generator circuit for Digital TV systems (CGC) .....	3-619
SAA9065 Video enhancement and D/A processor (VEDA) .....	3-626
TDA2595 Horizontal combination .....	3-644
TDA3566A PAL/NTSC decoder .....	3-651
TDA4665 Baseband delay line .....	3-669
TDA4670 Picture signal improvement (PSI) circuit .....	3-675
TDA4680 Video processor with automatic cut-off and white level control .....	3-685
TDA4686 Video processor, with automatic cut-off control .....	3-701
TDA4820T Sync separation circuit for video applications .....	3-717
TDA8444/AT/T Octuple 6-bit DAC with I <sup>2</sup> C-bus .....	3-722
TDA8446; TDA8446T Fast RGB/YC switch for digital decoding .....	3-731
TDA8501 PAL/NTSC encoder .....	3-738
TDA8540 4 × 4 video switch matrix .....	3-763
TDA8702 8-bit video digital-to-analog converter .....	3-776
TDA8703 8-bit high-speed analog-to-digital converter .....	3-790
TDA8706 6-bit analog-to-digital converter with multiplexer and clamp .....	3-803
TDA8707 Triple RGB 6-bit video analog-to-digital interface .....	3-813
TDA8708A Video analog input interface .....	3-825
TDA8708B Video analog input interface .....	3-842
TDA8709A Video analog input interface .....	3-859
TDA8712; TDF8712 8-bit digital-to-analog converters .....	3-878
TDA8714 8-bit high-speed analog-to-digital converter .....	3-893
TDA8716 8-bit high-speed analog-to-digital converter .....	3-908
TDA8718 8-bit high-speed analog-to-digital converter .....	3-924
TDA8755 YUV 8-bit video low-power analog-to-digital interface .....	3-933
TDA8758 YC 8-bit low-power analog-to-digital video interface .....	3-948
TDA8760 10-bit high-speed analog-to-digital converter .....	3-963
TDA8771 Triple 8-bit video digital-to-analog converter .....	3-984
TDA8772; TDA8772A Triple 8-bit video digital-to-analog converter .....	3-996
TDA9141 PAL/NTSC/SECAM decoder/sync processor .....	3-1010
TDF8704 8-bit high-speed analog-to-digital converter .....	3-1033

# Section 2

## Application Notes and Materials

### CONTENTS

DPC7110	Video capture card (24/16-bit) with display filter	2-3
DPC7116SD	Video to PCI demo board	2-17
Clock and synchronization signals of SAA7187 and SAA7188		
Application note for digital video encoder		2-30
DTV7188A	Evaluation board for SAA7188A encoder	2-48
DTV9051	Digital video evaluation module	2-54
DTV7199	Digital Television Demonstration System	2-68
SAA7199B	operational modes	2-93
DTV7194/96	Desktop video demo board	2-103
Crystal specifications		2-139
TDA8708	black level and gain modulation circuit	2-140
TDA9141	analog decoder application	2-143
Digital video evaluation board		2-149
CVBS output filter for SAA7199B encoder		2-157
SAA1101 sync generator application		2-162
The I <sup>2</sup> C-bus and how to use it (including specification)		2-163
I <sup>2</sup> C bus addresses		2-182
I <sup>2</sup> C parallel printer port adaptor		2-183
AN425	Interfacing the PCF8584 I <sup>2</sup> C-bus controller to 80C51 family microcontrollers	2-184
What is Teletext?		2-204
Packet and Page Teletext data reception using the SAA5250		2-213



## Video capture card (24/16-bit) with display filter

DPC7110

*Author: Herb Knies*

The demonstration schematic shown on the following pages is meant to be a baseline reference design showing the application of the Philips SAA7110 Single-Chip Video Decoder providing video overlay on the VGA monitor and capture on a standard PC ISA bus computer.

The board contains 4 basic elements to provide video display on the PC VGA monitor. The first element is the SAA7110 video decoder. It digitizes the incoming analog baseband video signals and decodes it into color difference information. Sync, clock and blanking signals are also provided to drive memory controllers such as the MCT MVM121A on this board.

The second function, as mentioned above, is to store the digital video data into memory. This particular board can use memory up to 24-bit RGB format, therefore, the MCT memory controller converts the digital YUV color difference data from the SAA7110 to 24-bit RGB internally before storing the data in VRAM. The memory controller's job is to write data to memory and scan convert it up on the read side to VGA timing frequencies supplied by connection to the VGA feature connector for sync and pixel clock.

The memory controller sits on the ISA bus directly for programming of display modes

and reading and writing video memory for record and playback of live video clips.

The third portion of the system is memory. This board uses VRAM so that the graphics display can make use of the serial port of VRAMs for high speed display. DRAM solutions would require 2 or 4 times the number of devices to meet the bandwidth requirements for video input and VGA display.

The fourth and final part of this system is the DAC and VGA output. On a typical display screen you might have graphics and live video at the same time. Under windows, a color key area is painted where the live video screen should appear. The memory controller listens to the data on the VGA feature connector along with sync and clock to tell the RGB DAC when to switch between digital RGB pixels from the video memory or analog VGA RGB from the graphics board. A short loop back cable must be connected from the VGA card output to the mini 8-pin DIN connector on the overlay board. This loop-back cable allows analog RGB from the VGA board to be mixed with analog video in the 24-bit DACs analog multiplexer. Do not force the connector into the SVIDEO connector, as it is only a 4-pin version.

Software comes with the demo board that auto installs under Windows 3.1 and higher. Video for Windows 1.1 is required for capture and play-back. You can get a copy from Microsoft. Video for Windows must be installed first. All you have to do is select the drive where the floppy is and type *install*. It will do the rest, you will have to answer *yes* several times, that's all.

After installing the software you must align the board for your particular VGA card and timing on the feature connector. Under the SETUP menu for the VMPLUS application for the board, you can select INPUT VIEWPORT, OUTPUT VIEWPORT, and VGA PARAMETERS to set up the board. After you remove any color key area overlap or noise caused by VGA feature connector timing errors, be sure to save your changes under the setup menu SAVE CHANGES.

There are a number of special effects you can experiment with, such as ZOOM, CHANGE PICTURE SIZE, etc. Be sure to check out the video control capability of the SAA7110 under VIDEO PARAMETERS. A parallel YUV connector is provided to allow connection to other signal processing boards. There is also a 24-bit RGB connector provided for connection to LCD panels. Be careful. The RGB connector runs non-interlaced at the VGA scan rates!

Revision History

Date	Rev No	Description
10-29-93	1.0	Vnr with SAA 7110 Eval Board
11-25-93	2.0	Display filter removed, optional 16/24 bit design Back annotation from layout
1-25-94	3.0	EPD FILTER Back annotation from layout

TITLE PAGE  
VIDEO CAPTURE CARD (24/16 BIT)  
WITH DISPLAY FILTER  
PHILIPS 7110 DECODER



Philips Semiconductors

PHILIPS

NOTICE:  
THESE SCHEMATICS ARE AN APPLICATION NOTE BASED ON THE  
DEVICE SPECIFICATIONS AVAILABLE AT THE DESIGN TIME.  
THE CIRCUIT IN THIS SCHEMATICS IS NOT REDUCED TO PRACTICE.

MCT, Inc. RESERVE ALL RIGHTS TO MODIFY THE INFORMATION  
IN THIS APPLICATION SCHEMATICS. MCT WILL NOT BE LIABLE  
FOR ANY ERROR IN THIS DOCUMENT OR INFRINGEMENTS OF PATENT  
HELD BY DIFFERENT PARTIES. FROM USE OF THIS APPLICATION  
SCHEMATICS.

(C) 1992,1993 MCT, Inc.

MEDIA COMPUTER TECHNOLOGIES, INC.  
2900 Lakeside Drive, Suite 101  
Santa Clara, California 95054  
TEL: (408) 988-2590 FAX: (408) 988-2671

113W  
R3P2.SCH  
R3P3.SCH  
R3P4.SCH  
R3P5.SCH  
R3P6.SCH  
R3P7.SCH  
R3P8.SCH

Reprinted with permission from Media Computers Technologies, Inc.

TITLE PAGE WITH PAGE LINK		
Size	Document Number	REV
is	VIDEO CAPTURE CARD	3.0
Date:	January 25, 1994	Sheet 1 of 8





Video capture card (24/16-bit) with display filter

DPC7110

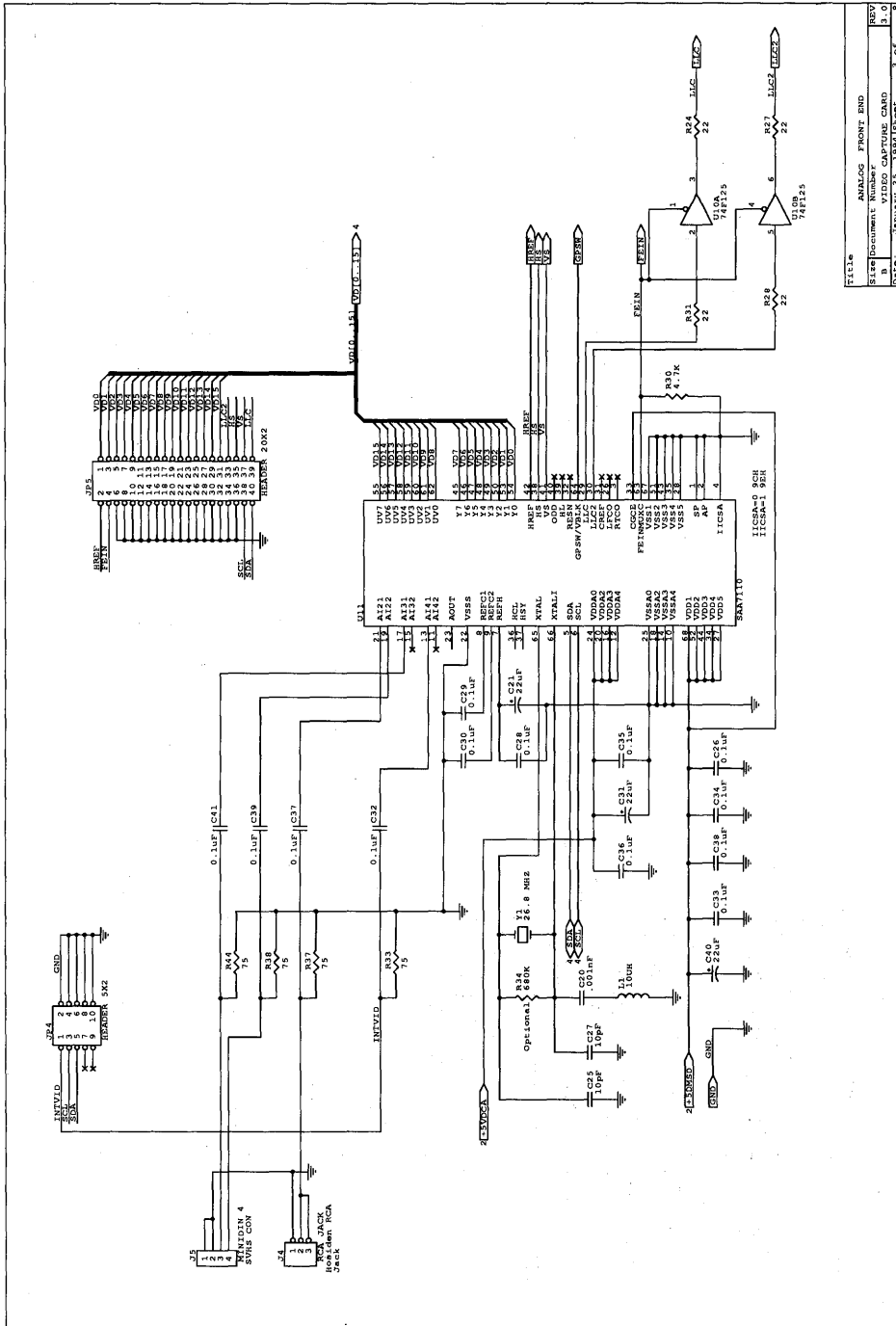
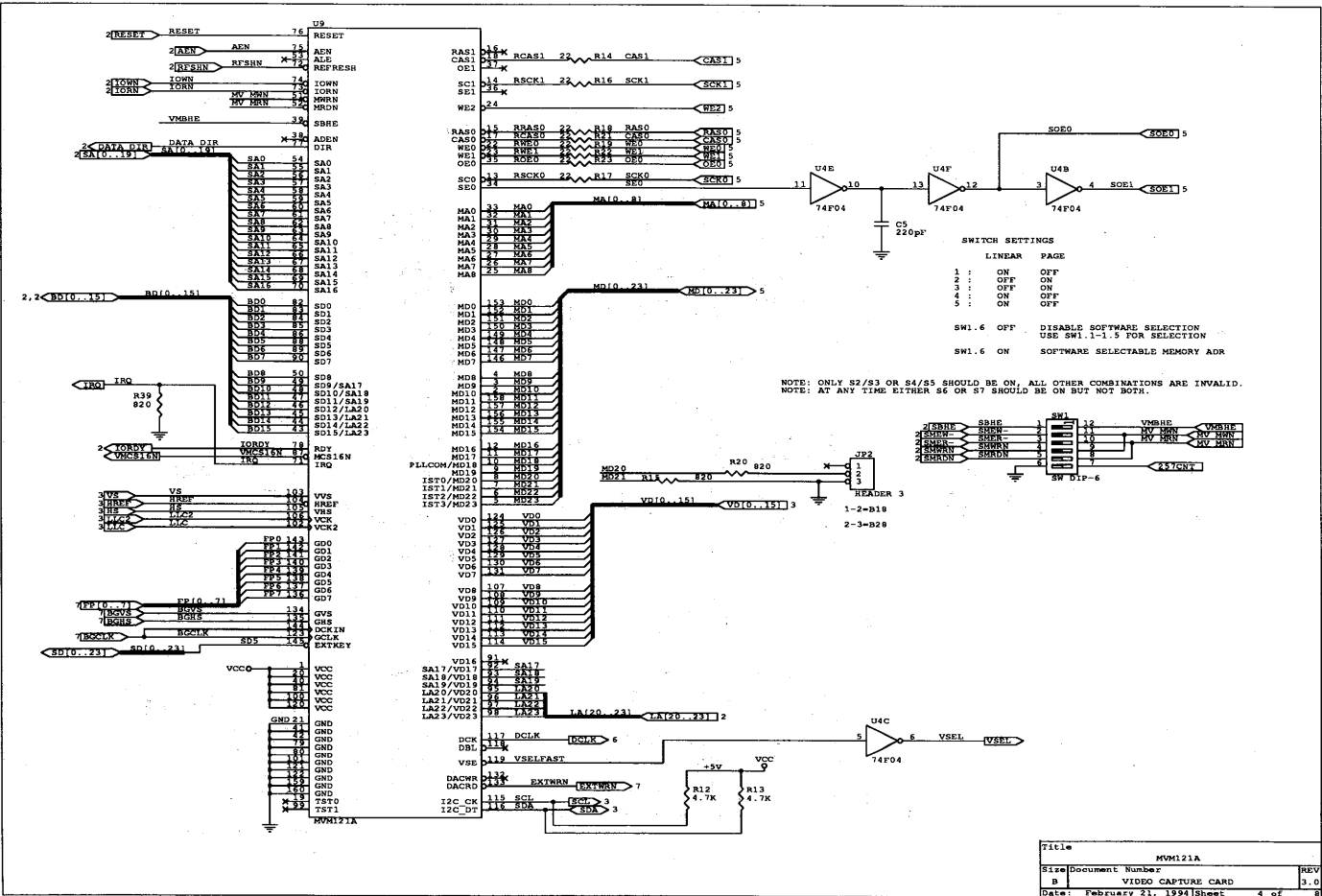

FIG. 3	ANALOG FRONT END
1	1
2	2
3	3
4	4
5	5
6	6
7	7
8	8
9	9
10	10
11	11
12	12
13	13
14	14
15	15
16	16
17	17
18	18
19	19
20	20
21	21
22	22
23	23
24	24
25	25
26	26
27	27
28	28
29	29
30	30
31	31
32	32
33	33
34	34
35	35
36	36
37	37
38	38
39	39
40	40
41	41
42	42
43	43
44	44
45	45
46	46
47	47
48	48
49	49
50	50
51	51
52	52
53	53
54	54
55	55
56	56
57	57
58	58
59	59
60	60
61	61
62	62
63	63
64	64
65	65
66	66
67	67
68	68
69	69
70	70
71	71
72	72
73	73
74	74
75	75
76	76
77	77
78	78
79	79
80	80
81	81
82	82
83	83
84	84
85	85
86	86
87	87
88	88
89	89
90	90
91	91
92	92
93	93
94	94
95	95
96	96
97	97
98	98
99	99
100	100

Video capture card (24/16-bit) with display filter

DP07110





# Video capture card (24/16-bit) with display filter

DPC7110

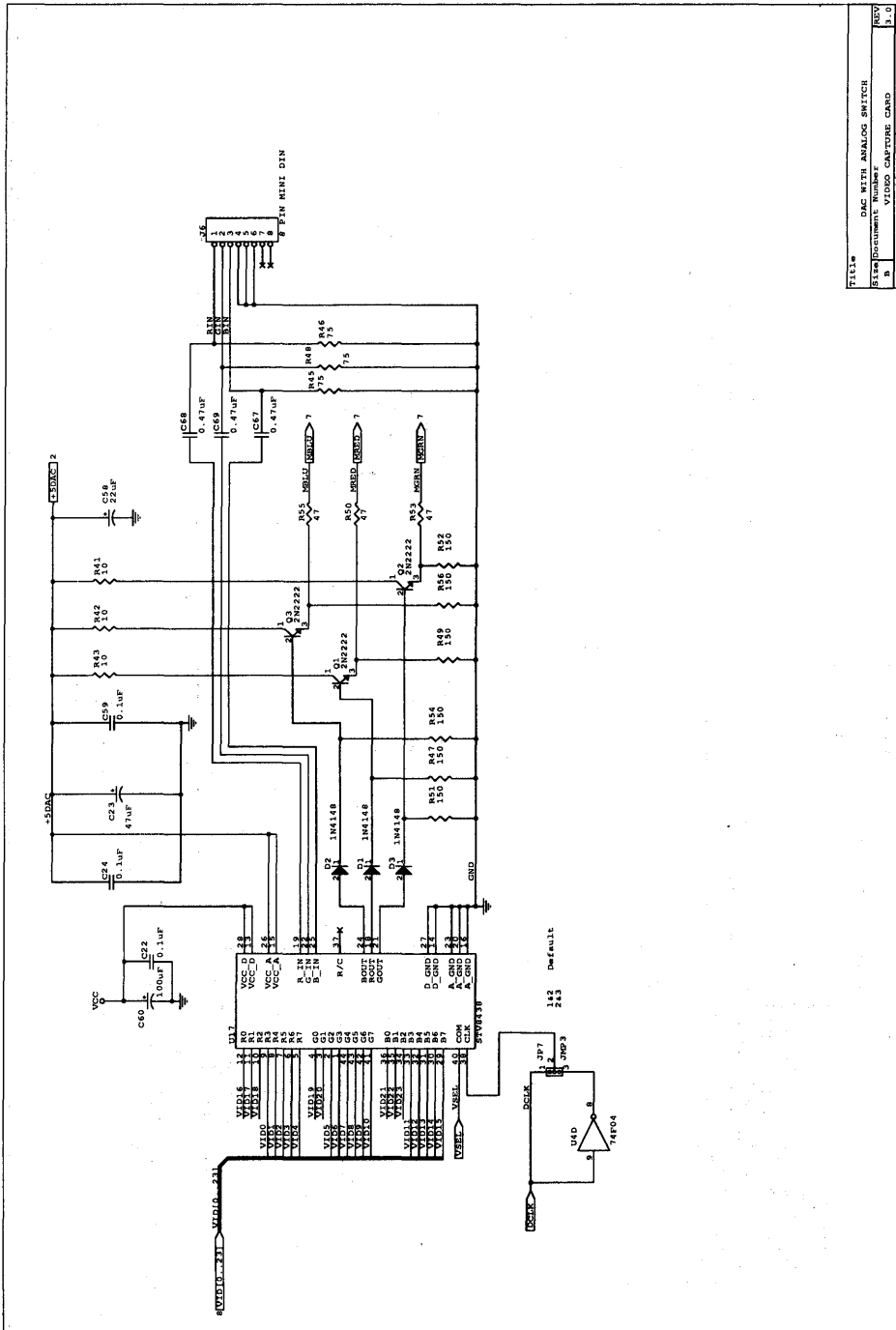





Video capture card (24/16-bit) with display filter

DPCC7110

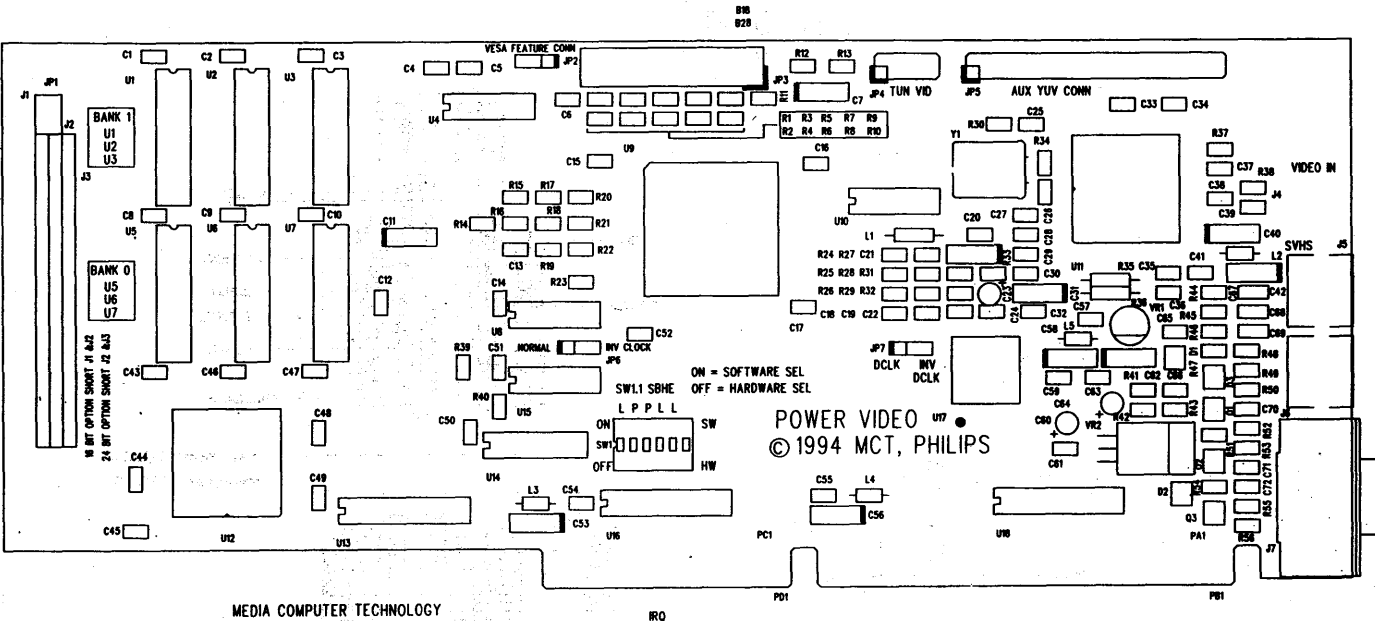

MEDIA COMPUTER TECHNOLOGY  
7110 EVAL BOARD REV.B  
SILKSCREEN  
31-JAN-94



Video capture card (24/16-bit) with display filter

DPC7110

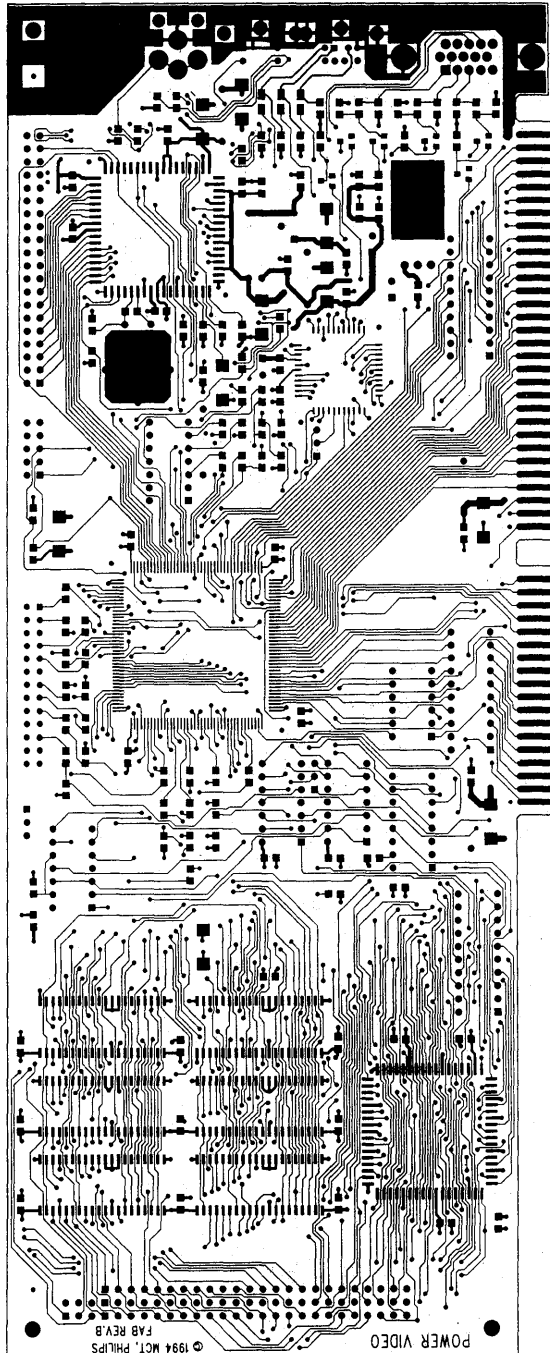

MEDIA COMPUTER TECHNOLOGY  
7110 EVAL BOARD REV.B  
COMPONENT SIDE  
31-JAN-94

Video capture card (24/16-bit) with display filter

DPC7110

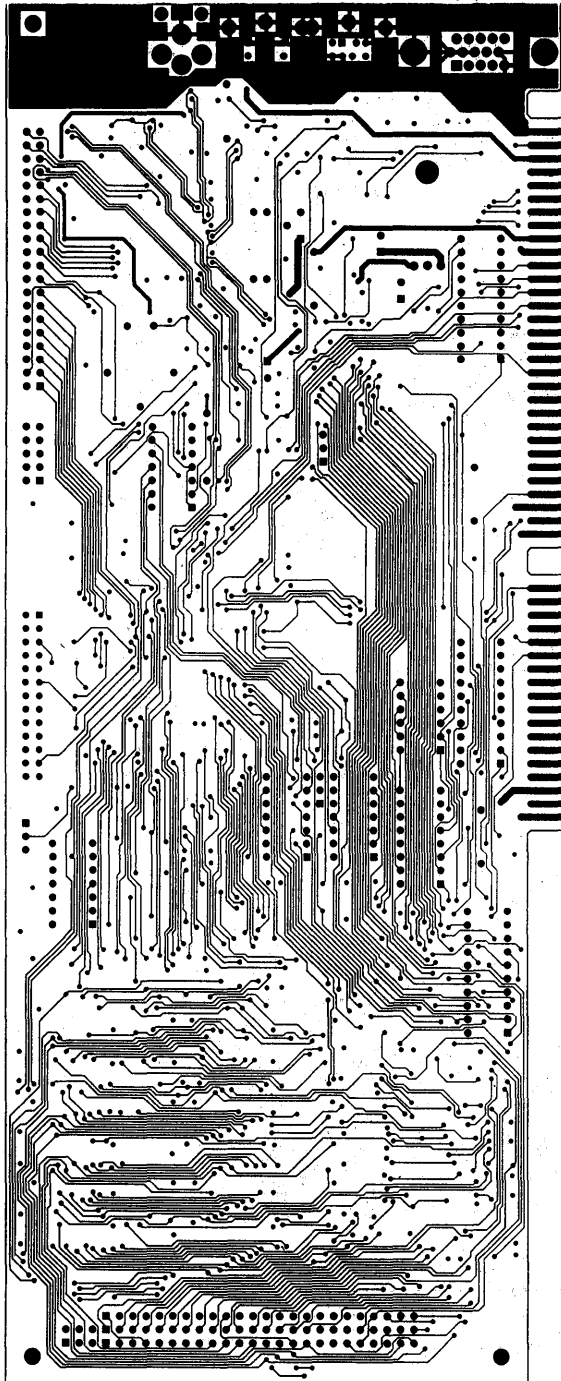

MEDIA COMPUTER TECHNOLOGY  
7110 EVAL BOARD REV.B  
SOLDER SIDE  
31-JAN-94

## Video capture card (24/16-bit) with display filter

DPC7110

Media Computer Technologies  
January 25, 1994  
7110 Fab Rev B BOM  
Bill Of Materials

February 1, 1994

Revised:  
Revision: 3.0  
11:05:12

See Notes on stuffing option

Item	Quantity	Reference	Part
1	8	C1,C2C8,C9,C10,C43,C47,C49	0.33uF
2	36	C3,C4,C12,C13,C14,C15,C16,C17, C22,C24,C26,C28,C29,C30,C32, C33,C34,C35,C36,C37,C38,C39, C41,C44,C45,C46,C48,C50,C51, C52,C54,C55,C57,C59,C61,C65	0.1uF
3	2	C5,C6	220pF
4	11	C7,C11,C21,C31,C40,C42,C53, C56,C58,C62,C64	22uF
5	2	C19,C18	1000pF
6	1	C20	.001nF
7	1	C23	47uF
8	2	C25,C27	10pF
9	1	C60	100uF
10	2	C63,C66	0.01uF
11	3	C67,C68,C69	0.47uF
12	3	C70,C71,C72	47pF
13	3	D1,D2,D3	1N4148
14	1	JP1	HEADER 3X2
15	1	JP2	HEADER 3
16	1	JP3	HEADER 13X2
17	1	JP4	HEADER 5X2
18	1	JP5	HEADER 20X2
19	2	JP7,JP6	JMP3
20	3	J1,J2,J3	CON24
21	1	J4	RCA JACK
22	1	J5	MINIDIN 4
23	1	J6	8 PIN MINI DIN
24	1	J7	DB15 HD
25	1	L1	10UH
26	4	L2,L3,L4,L5	F.BEAD
31	3	Q1,Q2,Q3	2N2222
32	13	R1,R3,R4,R5,R6,R7,R8,R9,R10, R11,R50,R53,R55	47
33	5	R2,R15,R20,R39,R40	820
34	3	R12,R13,R30	4.7K
35	16	R14,R16,R17,R18,R19,R21,R22, R23,R24,R25,R26,R27,R28,R29, R31,R32	22
36	7	R33,R37,R38,R44,R45,R46,R48	75
38	1	R35	180
39	4	R36,R41,R42,R43	10
40	6	R47,R49,R51,R52,R54,R56	150
41	1	SW1	SW DIP-6
42	6	U1,U2,U3,U5,U6,U7	MT42C8255_S
43	1	U4	74F04
44	2	U10,U8	74F125
45	1	U9	MVM121A
46	1	U11	SAA7110
47	1	U12	EPM7064LC68
48	1	U13	16L8
49	1	U14	74F257
50	1	U15	74F74
51	2	U18,U19	74F245
52	1	U17	STV8438
53	1	VR1	78L05
54	1	VR2	LM7805
55	1	Y1	26.8 MHz

## Video capture card (24/16-bit) with display filter

DPC7110

All resistors are 5% unless noted

## Notes

1. U12 7064EPLD needed for Horizontal filter only  
This filter can e used only in 16bit RGB board.
2. For 512K, 24 bit RGB board, do not stuff U1,U2,U3  
Short J2 & J3 for 24 bit RGB board
3. For 1024K, 24 bit RGB board, Short J2 & J3
4. For 512K, 16 bit RGB board do not stuff U1,U2,U3,U7  
Stuff U12 for horizontal filter OR Short J1 & J2
5. For 1024K 16 bit RGB board do not stuff U3,U7  
Stuff U12 for horizontal filter OR Short J1 & J2
6. Do not stuff R34 ( 680K )

## Video to PCI demo board

## DPC7116SD

*Author: Herb Kniess*

The schematics following on the next few pages show the application reference design of a complete audio and video board operating on a personal computer equipped with a PCI local bus. The board will digitize, decode, scale, and send video data to 2 different PCI memory locations. PCI bus is the latest high speed local bus for personal computers. Pentium, 486, and even POWER PC systems can make use of such a system bus for transferring large amounts of high speed data, such as full motion video, directly to CPU memory or graphics screen without the need for an additional frame buffer. The cost savings is obvious. This concept is known as SHARED FRAME BUFFER.

The PCI bus has 100 MBytes of useable data bandwidth. At peak, this video capture card could produce 45 mbytes of 24-bit RGB data if a full screen high resolution PAL video signal was connected to one of the video inputs. In practice 20–30 mbytes is a more realistic number for data bandwidth requirements of high quality full motion video. Small pictures and slow frame rates will reduce the data rates even further if necessary.

The board contains a TV tuner, BTSC stereo audio decoder for TV sound, video decoder and picture scaler, and single chip PCI bus interface. The SAA7116 contains all circuitry necessary for a complete interface between the Philips SAA7196 video decoder scaler output bus and PCI bus. The SAA7116 is a PCI bus master and contains an internal 1 KByte FIFO to decouple realtime video data

rates and the PCI bus burst transfer modes. The FIFO size is very generous in order to accommodate worst-case conditions on PCI bus data transfers.

This demo board is not just a technology demonstration of the products mentioned above, but satisfies the needs of the computer industry to bring video into a PCI equipped computer at minimum possible cost. There is no wasted hardware or additional cost to the customer once a PCI equipped computer has been purchased in order to add video. There is no secondary frame buffer needed to convert video data rates to graphic data rates. The SAA7116 makes use of the SHARED FRAME BUFFER concept.

### OPERATION

Analog video signals are supplied to the board and are digitized by the TDA8708 or TDA8709 A/D converters. The digital composite video data is passed to the SAA7196 video decoder scaler. The decoder function is necessary to convert the video data into color difference YUV or RGB data formats for the graphics frame buffer or CPU. The SAA7196 will decode NTSC, PAL, or SECAM video standards. The decoder also generates pixel clock and sync signals to feed the scaler portion of the SAA7196. The scaler function will reduce the picture size with proper filtering vertically and horizontally to provide a picture of any size as required by an application. The SAA7196 has an optional

YUV data port for external signal connection as provided by connector J4 on the board. Do not connect the composite or S-VIDEO inputs at the same time because they share the same input on the TDA8708 data converter.

A Philips FI 1236F TV tuner is also provided on the board to optionally send baseband audio and video signals to the signal processing devices. Audio signal processing is handled by the TDA9855 stereo TV decoder. It contains a complete stereo decoder function as well as volume, treble, bass, pseudo-stereo, and mixing functions. All devices, including the TV tuner, are controlled via the I<sup>2</sup>C serial 2-wire bus generated in the SAA7116 PCI interface. Software drivers are supplied with the board which run under VIDEO FOR WINDOWS VIDCAP V1.1.

Under WINDOWS VIDCAP, you can select direct PCI transfer to the graphics display buffer or transfer to CPU memory. If the video data is sent to CPU memory, the frame update rate is limited by the ability of the CPU to transfer data to the screen. The transfer rate will not be real time 30 frames/second. Even a Pentium system cannot handle video data rates as high as direct transfer to the frame buffer at 24 MBytes/sec.

Drivers for VIDCAP and other applications are available to support the WINDOWS development environment. Philips Semiconductors will make interface documentation and software support available on a developer basis.

## Video to PCI demo board

DPC7116SD

## SAMPLE MACRO FILE FOR SAA7116 DEBUGGER

```

;filename: v16p.mac
;This file initializes the SAA7116 to send RGB15 640x480
;with CCIR 601 compatible levels to a frame buffer located at 0xa0200000

[PEG]
MEM(60)=00000000 ; I2C COMMAND/STATUS
MEM(40)=00000000 ; CAPTURE CONTROL
WAIT(01)=000fffff
MEM(40)=00000040 ; CAPTURE CONTROL
WAIT(01)=000fffff
MEM(00)=00000004 ; DMA1E
MEM(04)=00000004 ; DMA2E
MEM(08)=00000004 ; DMA3E
MEM(0c)=00000004 ; DMA1O
MEM(10)=00000004 ; DMA2O
MEM(14)=00000004 ; DMA3O
MEM(8c)=00000000 ; DMA_E_END
MEM(90)=00000000 ; DMA_O_END
MEM(5c)=80404020 ; PHASE
MEM(40)=000080c0 ; CAPTURE CONTROL
I2C(400e)=38
I2C(400f)=50
MEM(40)=00008040 ; CAPTURE CONTROL
WAIT(01)=000fffff

;The SAA7116 is initialized at this point
MEM(00)=a0200000 ; DMA1E
MEM(04)=00000000 ; DMA2E
MEM(08)=00000000 ; DMA3E
MEM(0c)=a0200800 ; DMA1O
MEM(10)=00000000 ; DMA2O
MEM(14)=00000000 ; DMA3O
MEM(18)=00000b00 ; STRD1E
MEM(1c)=00000000 ; STRD2E
MEM(20)=00000000 ; STRD3E
MEM(24)=00000b00 ; STRD1O
MEM(28)=00000000 ; STRD2O
MEM(2c)=00000000 ; STRD3O
MEM(30)=eeeeee01 ; MODE_E
MEM(34)=eeeeee01 ; MODE_O
MEM(38)=00200020 ; FTRIG_PLA, FTRIG_PAC
MEM(3c)=00000103 ; AMODE, FTOGGLE, INCDEC_E, INCDEC_O
MEM(40)=000000c0 ; CAPTURE CONTROL - reset prst
MEM(44)=00000000 ; RETRY_WAIT
MEM(48)=00000000 ; INTERRUPT MASK
MEM(4c)=00000001 ; MASK_E
MEM(50)=00000001 ; MASK_O
MEM(54)=00000000 ; MLEN_E, MLEN_O
MEM(58)=0005007c ; FAEMPTYFLAG, FAFULLFLAG
MEM(5c)=461e1e0f ; PHASE
MEM(60)=00000000 ; I2C COMMAND/STATUS
MEM(64)=00000000 ; I2CD
MEM(68)=00000000 ; I2CD1_E, I2CD0_E
MEM(6c)=00000000 ; I2CD3_E, I2CD2_E
MEM(70)=00000000 ; I2CD5_E, I2CD4_E
MEM(74)=00000000 ; I2CD7_E, I2CD6_E
MEM(78)=00000000 ; I2CD1_O, I2CD0_O
MEM(7c)=00000000 ; I2CD3_O, I2CD2_O
MEM(80)=00000000 ; I2CD5_O, I2CD4_O
MEM(84)=00000000 ; I2CD7_O, I2CD6_O
MEM(88)=00000000 ; I2CD_EN_O, I2CD_EN_E
MEM(8c)=a02eece4 ; DMA_E_END
MEM(90)=a02ef4e4 ; DMA_O_END
I2C(4000)=50

```

## Video to PCI demo board

DPC7116SD

```
I2C(4001)=7f
I2C(4002)=53
I2C(4003)=43
I2C(4004)=19
I2C(4005)=00
I2C(4006)=46
I2C(4007)=00
I2C(4008)=7f
I2C(4009)=7f
I2C(400a)=7f
I2C(400b)=7f
I2C(400c)=40
I2C(400d)=84
I2C(4010)=00
I2C(4011)=2c
I2C(4012)=40
I2C(4013)=40
I2C(4014)=34
I2C(4015)=0c
I2C(4016)=fb
I2C(4017)=d4
I2C(4018)=ec
I2C(4019)=80
I2C(4020)=90
I2C(4021)=80
I2C(4022)=80
I2C(4023)=04
I2C(4024)=8a
I2C(4025)=f0
I2C(4026)=f0
I2C(4027)=0f
I2C(4028)=80
I2C(4029)=16
I2C(402a)=00
I2C(402b)=00
I2C(402c)=00
I2C(402d)=00
I2C(402e)=00
I2C(402f)=00
I2C(4030)=8f
MEM(40)=00008ff3 ; CAPTURE CONTROL - enable pegasus
[]
```

# Video to PCI demo board

DPG7116SD

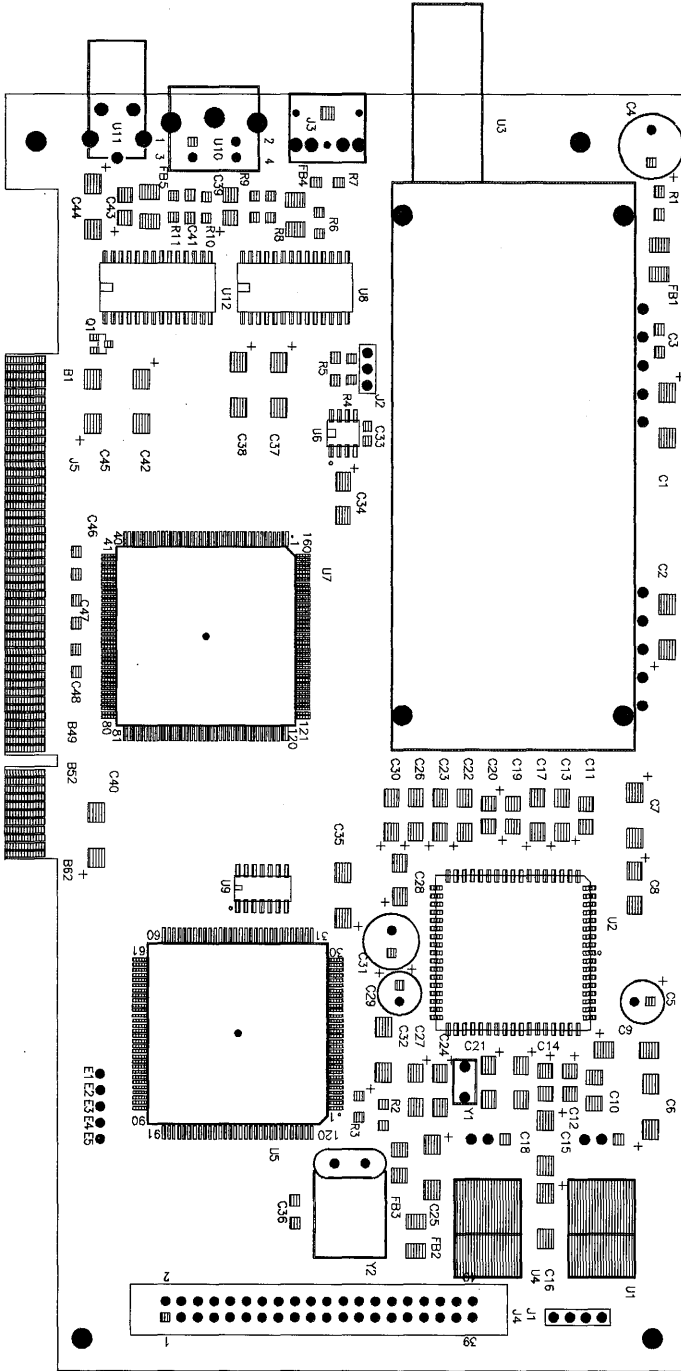



# Video to PCI demo board

DP07116SD

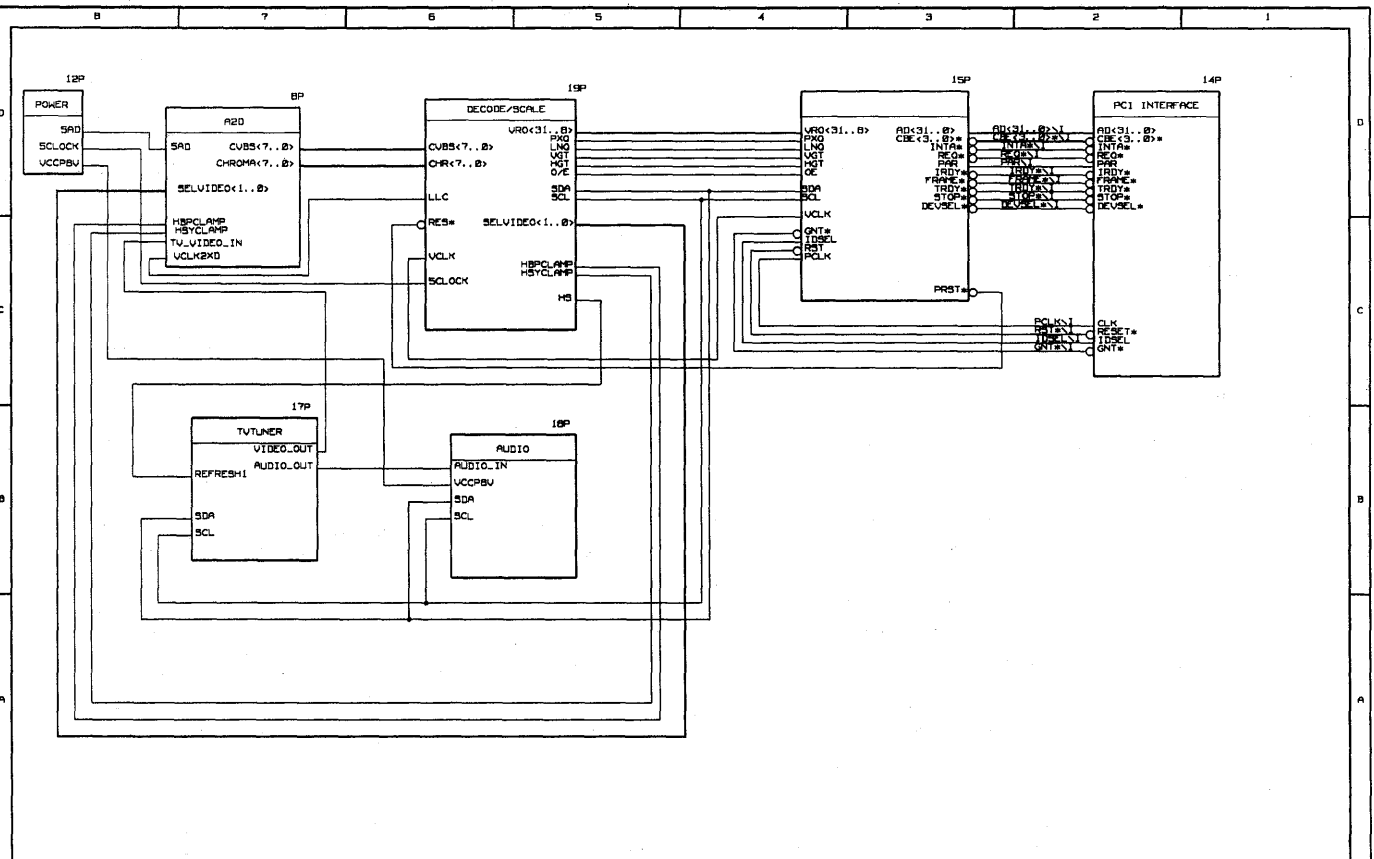

Video to PCI demo board

DPCT116SD

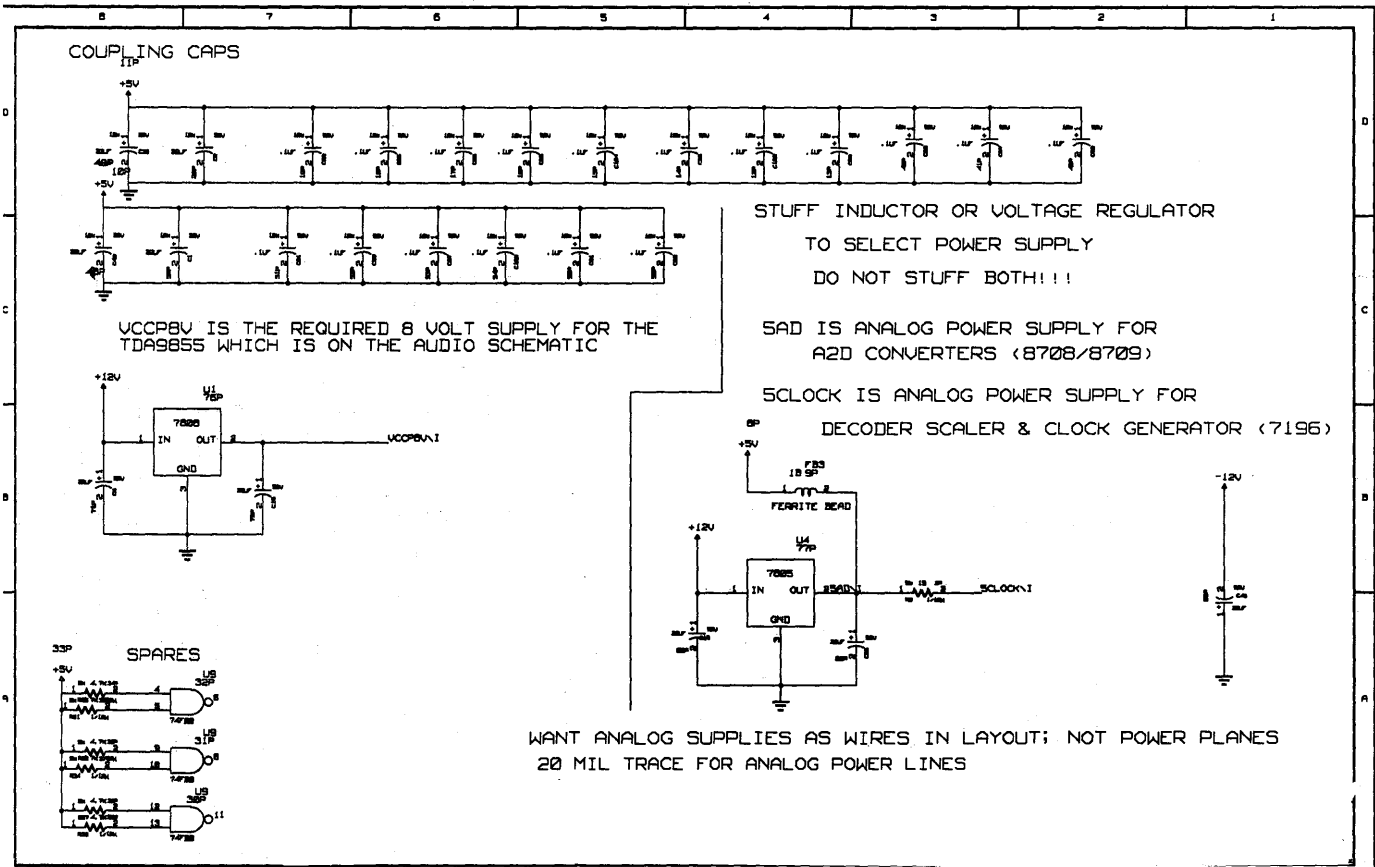

Video to PCI demo board

DPC7116SD

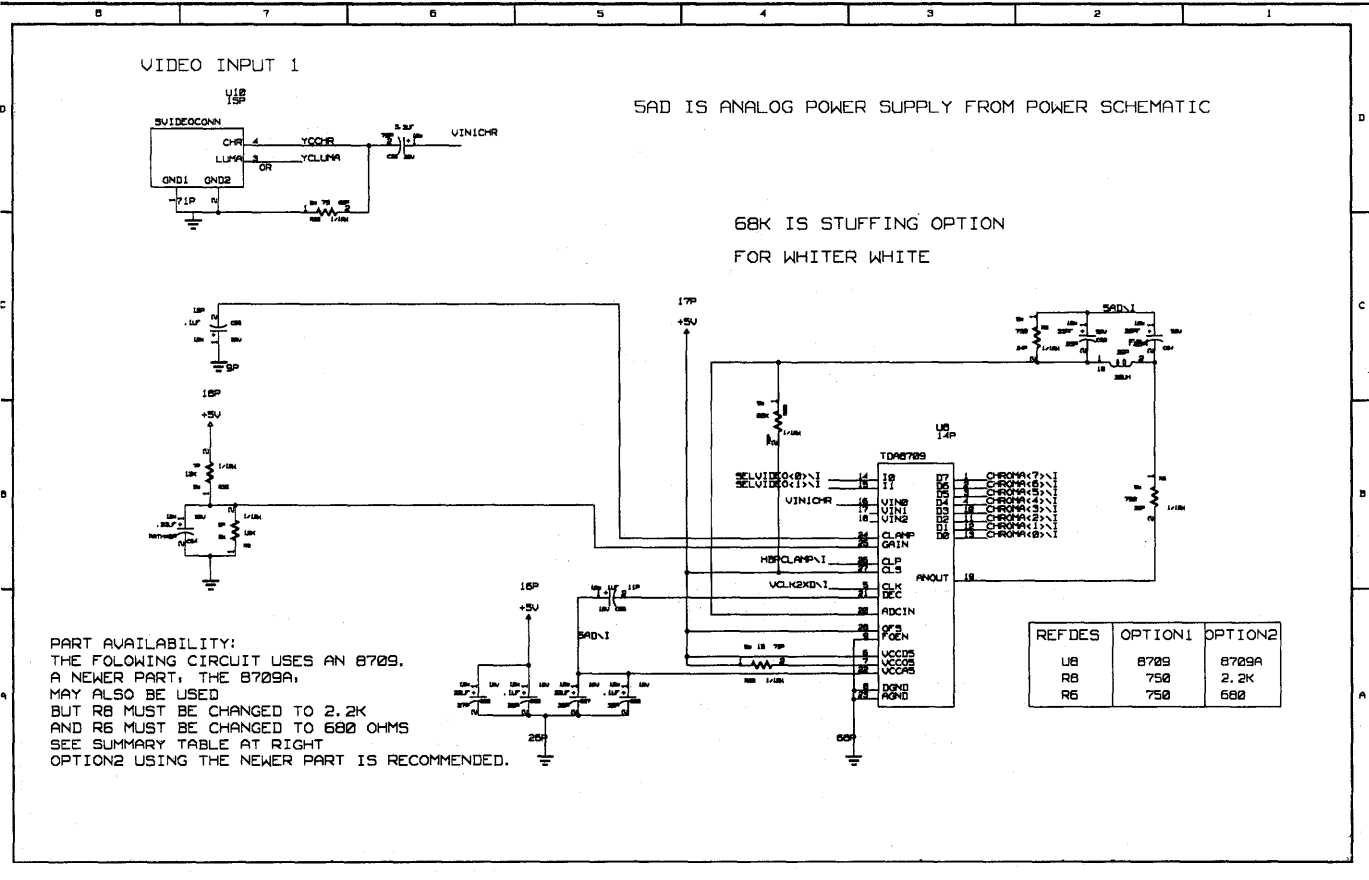



Video to PCI demo board

DPc7116SD

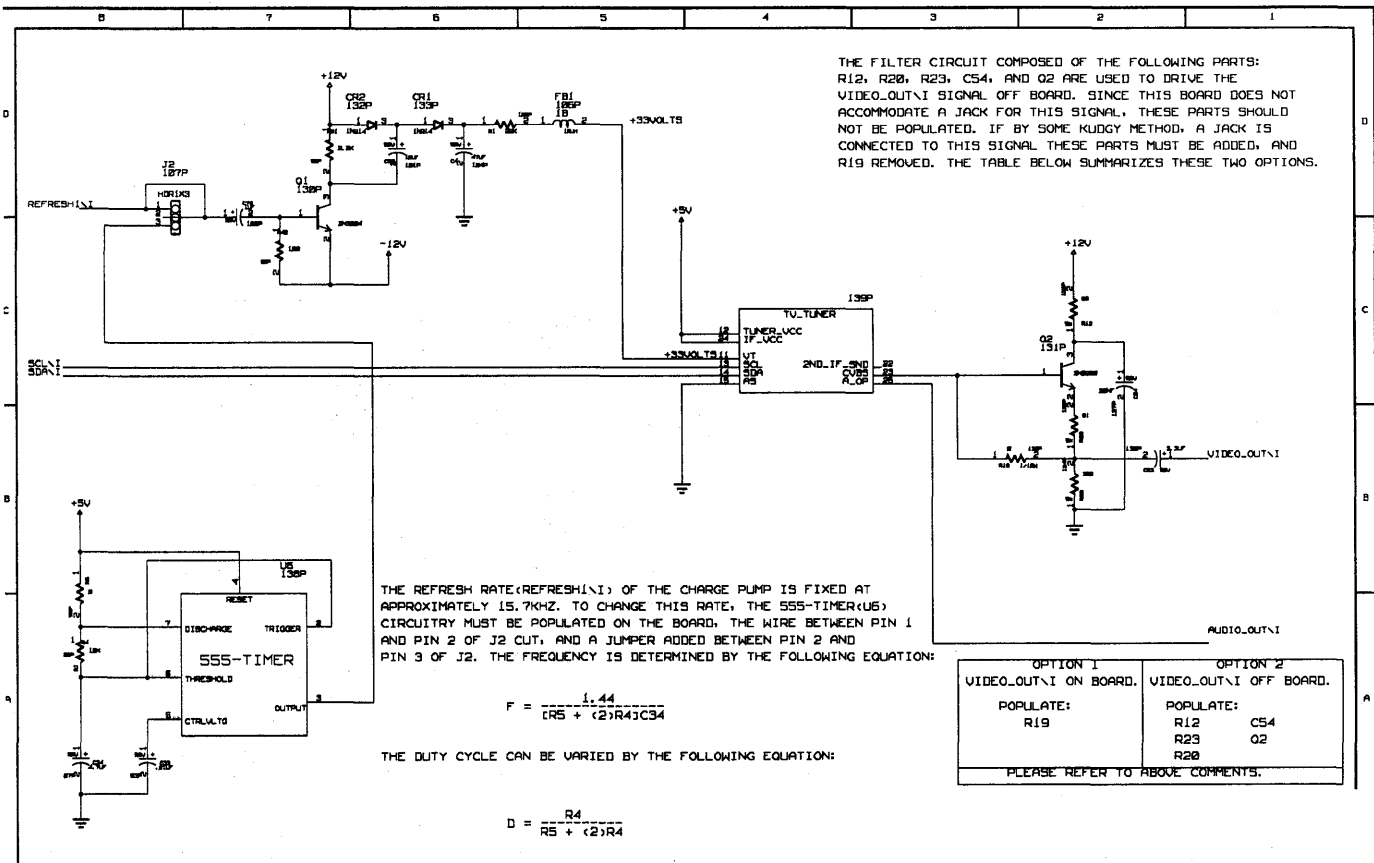

Video to PCI demo board

DPC7116SD

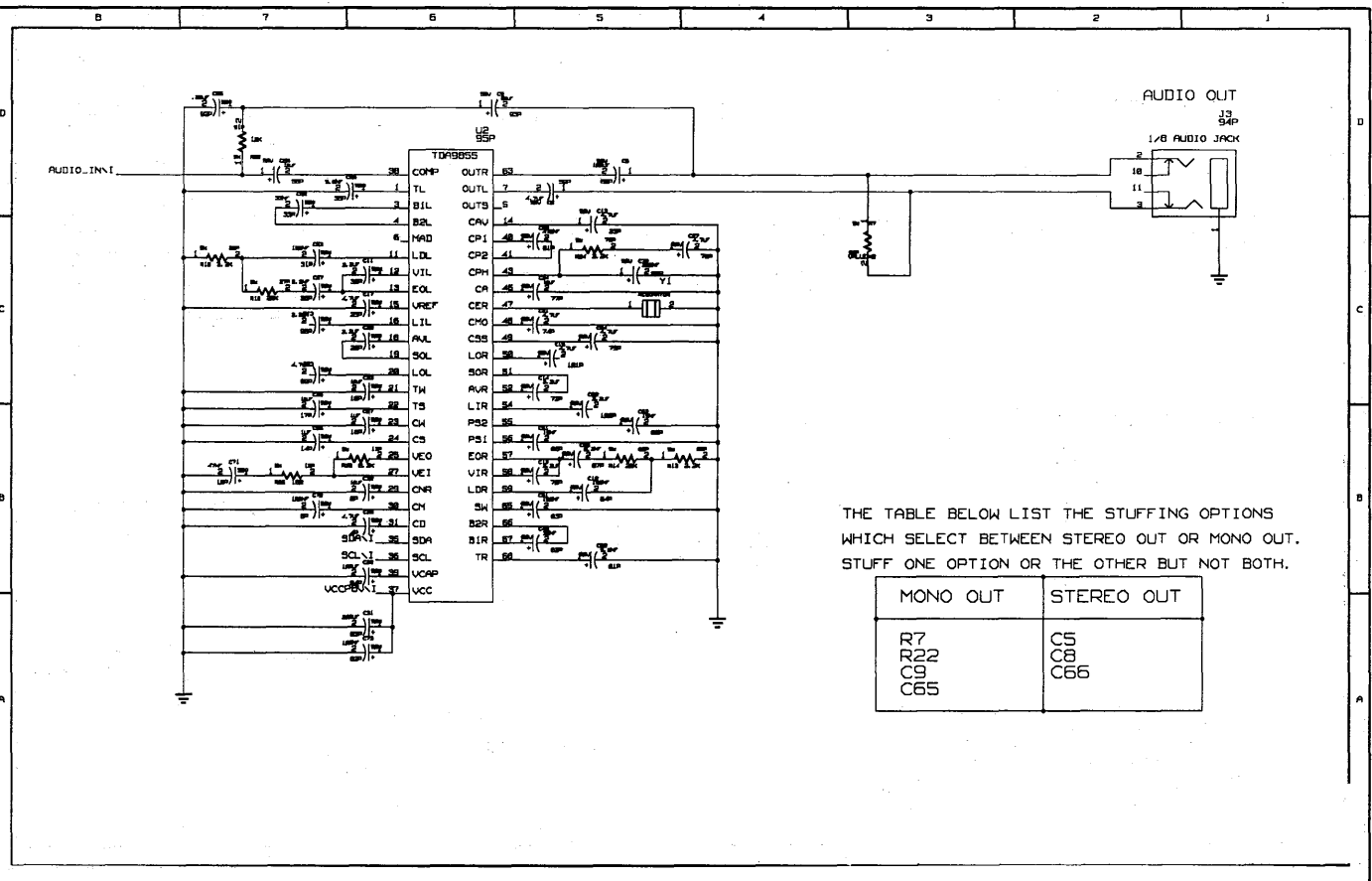

THE TABLE BELOW LIST THE STUFFING OPTIONS WHICH SELECT BETWEEN STEREO OUT OR MONO OUT. STUFF ONE OPTION OR THE OTHER BUT NOT BOTH.

MONO OUT	STEREO OUT
R7	C5
R22	C8
C9	C66
C65	



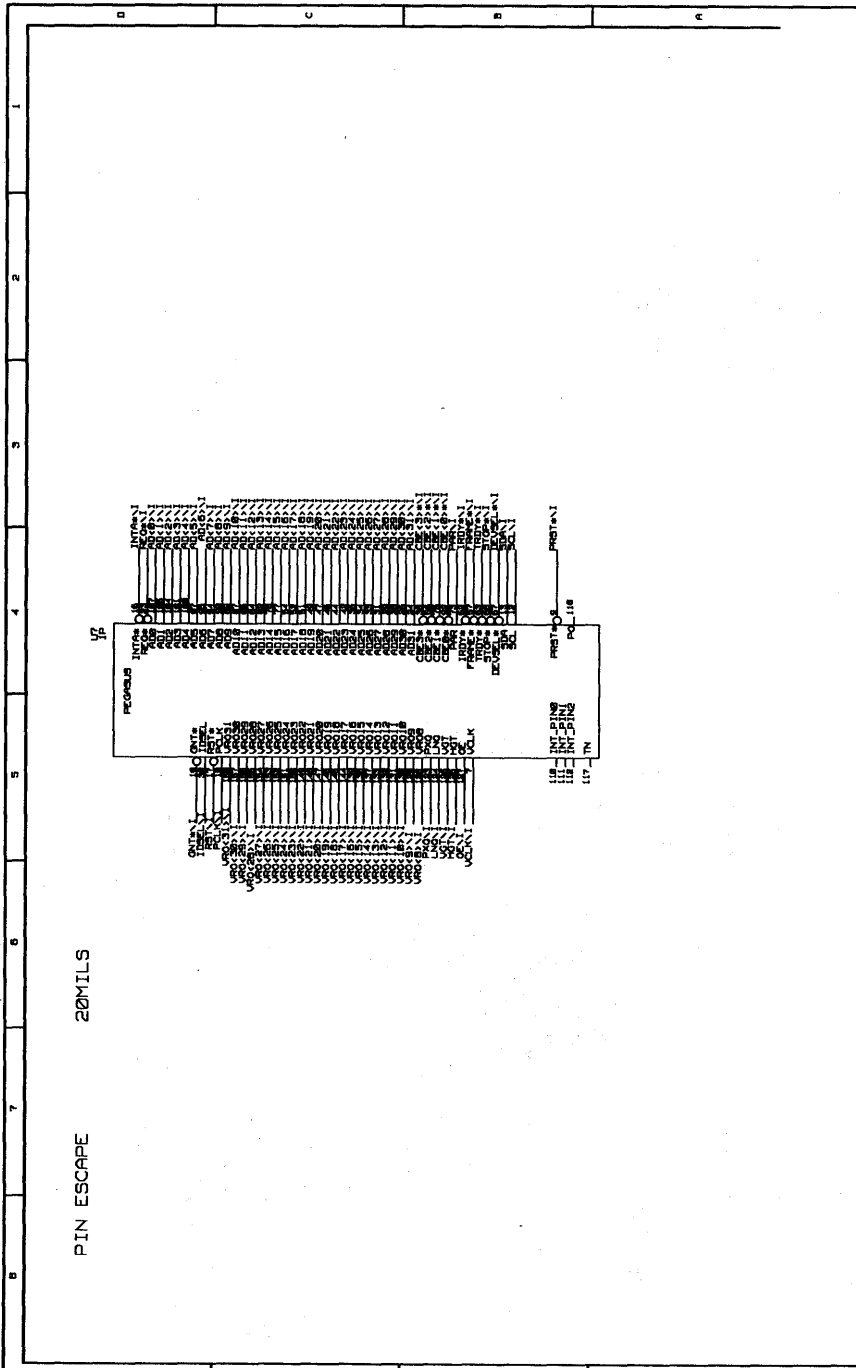



Video to PCI demo board

DPC7116SD

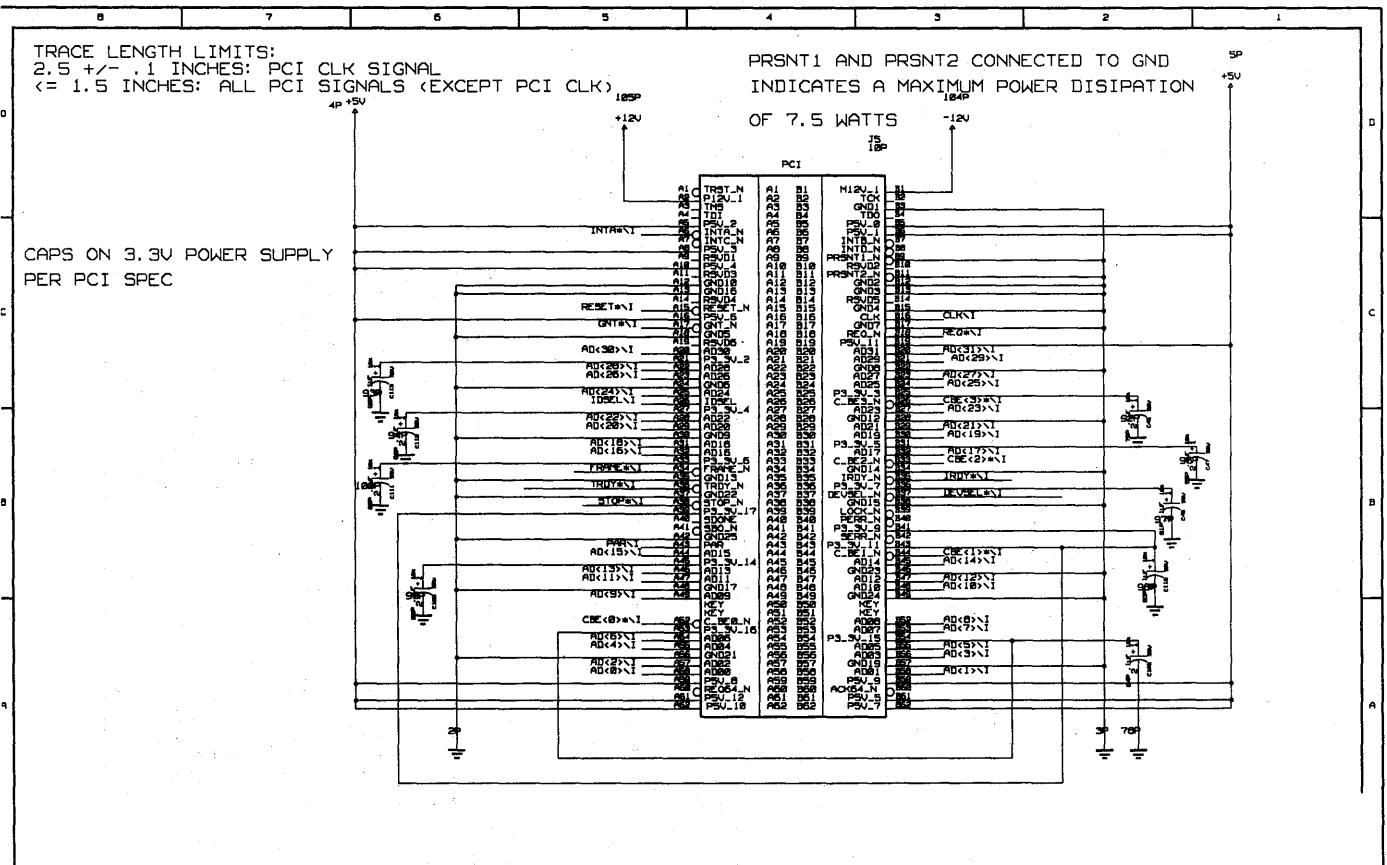

# Clock and synchronization signals of SAA7187 and SAA7188

## Application note for digital video encoder

Author: Leo Warmuth.

### 1.0 INTRODUCTION

The devices of the SAA7187/88 family of video encoders can be used in a variety of applications differing regarding the signal flow of timing information. Video timing is defined by clock signals, synchronization signals and blanking signals. The video encoder ICs can generate these signals by itself (master mode), or can accept them as input (slave mode). The master/slave characteristic can be chosen independently for clock and sync-signals.

This application note describes the various clock and synchronization signals, their functions, and how to select and program them. The timing relation of some of these signals is programmable. An application example shows a possible configuration.

### 2.0 CLOCK LLC AND CREF SIGNAL

The SAA7187/88 has two clock signals: LLC and CREF, functionally compatible with other Philips digital video processing circuits. LLC on pin 38 is the Line-Locked-Clock in double pixel clock frequency. CREF on pin 39 is the clock qualifier signal, accompanying LLC, to indicate on which LLC edges the 16 bit wide YUV data stream transports valid data. CREF is continuously toggling in pixel rate frequency, but is not meant as pixel clock. The transitions of CREF have to maintain certain setup and hold times relative to clock LLC (see data sheet). The digital encoder ICs can generate and provide (drive) the clock signals by its own by means of the built-in

crystal oscillator, or receive the clock signals from external. In remote genlock mode, LLC and CREF can be fed from one of the Philips digital decoder (DMSD), but must then be accompanied by RTC signal (real time control information).

### 2.1 Built-in clock signal generator

SAA7187/88 has built-in an optional crystal oscillator for LLC frequency. A crystal with double pixel clock frequency as base frequency, or as third harmonic frequency, with appropriate auxiliary circuitry, can be connected between the pins XTALi (input, pin 41) and XTALo (output, pin 40). The swing at the XTAL-pins is about 1Vpp, and is DC-compensated via an internal resistor between the two pins. Alternatively an external crystal oscillator could directly drive into XTALi.

An internal switch, hardware controlled by CDIR at pin 36, selects whether the IC provides or receives clock signals LLC and CREF (see Table 1). If CDIR is low, clock is taken from the internal crystal oscillator and the IC outputs LLC at pin 38 and CREF at pin 39. If CDIR is high, LLC pin and CREF pin are both switched to be input. The IC then requires a double pixel clock LLC from external circuitry at pin 38. Under certain conditions, CREF input at pin 39 has data-phase (timing) relevance, but it does not have directly clock and data qualifying function.

### 2.2 External Clock

In the "clock slave mode" case, i.e., if clock is provided from external into LLC pin 38, a CREF-like signal can optionally be applied to pin 39, but this is not required. If the IC sees a toggling signal, i.e., edges, at pin 39, CREF will contribute to re-synchronization of the internal horizontal counter (once per line) and – by that – defines the active data phases in the 16 bit wide YUV input data stream. If horizontal synchronization from external via RCV1 or RCV2 is selected, i.e., the encoder IC is in slave mode regarding horizontal timing, CREF defines together with the selected horizontal reference input signal, when the horizontal trigger counter has to start. From there the programming parameter HTRIG (11 bits in subaddress 6E and 6F) defines the start of the horizontal pixel counter, and the LSB of the parameter HTRIG determines one of the two possible phases of the internally effective CREF relative to the external provided CREF. The horizontal reference edge is defined regarding source and polarity by the various bits in subaddress 6Chec (see also later in this application note: re-trigger).

If no CREF is provided to the IC, a horizontal reference signal input is sampled direct with LLC resolution. The phase of the internal CREF, and expected valid data phases, are defined by the selected horizontal reference edge, and by the LSB of HTRIG. The horizontal reference edge is defined regarding source and polarity by the various bits in subaddress 6Chec (see also later in this application note: re-trigger).

Table 1. Selection of Clock Modes

CDIR	LLC	CREF	XTALo	XTALi	RTCI	RTCE
Pin 36	Pin 38	Pin 39	Pin 40	Pin 41	Pin 43	subaddress 61hex
low	output	output	local crystal		don't care	don't care
low	output	output	don't care	external oscillator	don't care	don't care
high	input	don't care but constant	don't care		don't care	0
high	input	input	don't care		don't care	0
high	input from DMSD/CGC	don't care but constant	don't care		RTCO from DMSD	1
high	input from DMSD/CGC	input from DMSD/CGC	don't care		RTCO from DMSD	1

# Clock and synchronization signals of SAA7187 and SAA7188

## Application note for digital video encoder

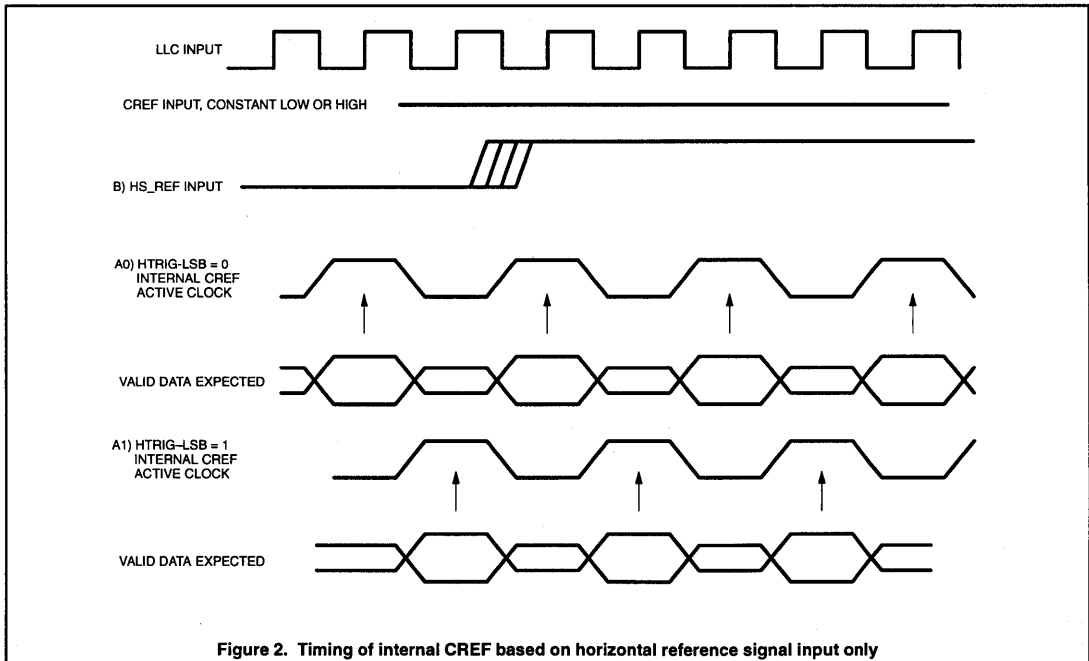
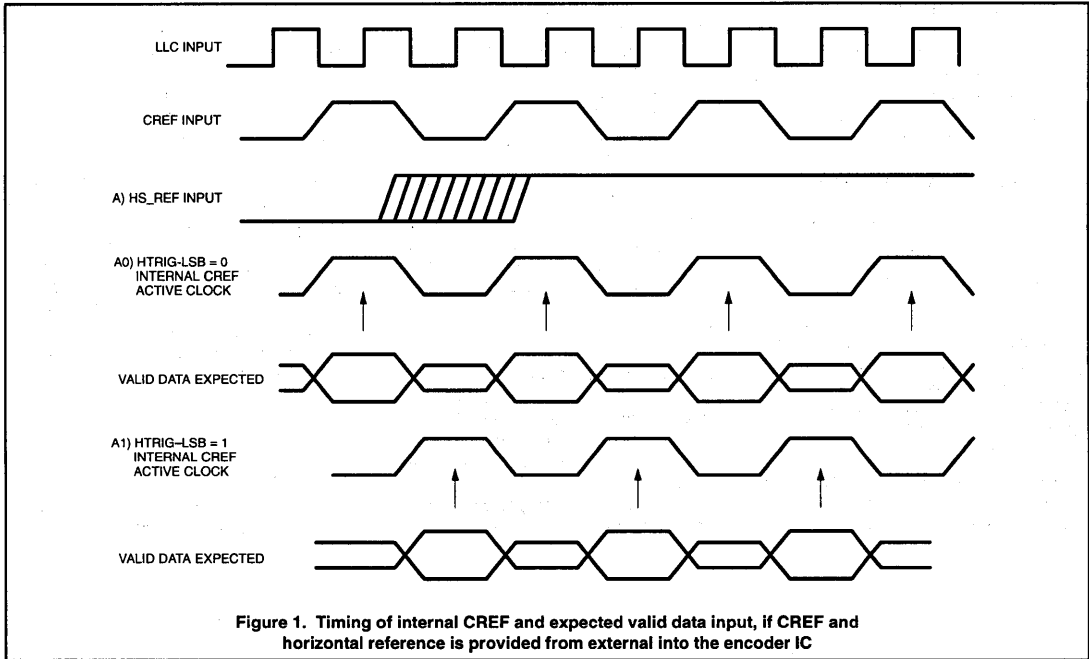

---

## Clock and synchronization signals of SAA7187 and SAA7188

### Application note for digital video encoder

---

#### 2.3 Clock accuracy

The digital encoder SAA7187 and SAA7188A synthesize all horizontal and vertical timing as well as the color subcarrier oscillation from the provided clock LLC, respectively crystal. If the clock frequency deviates from its nominal value, line and field frequency will change accordingly. Consumer type receiver equipment is rather tolerant regarding these raster frequencies, and can normally accept and follow several % deviations from the standard raster frequencies.

But the subcarrier frequency has much higher requirements regarding accuracy and stability to ensure proper color decoding. Broadcast quality class specification asks for less than 2ppm deviation of subcarrier frequency. Consumer type equipment may accept up to 50ppm static deviation, but dynamic deviation should be kept much smaller and very slow.

In case the crystal or the provided LLC at the digital encoder does not have the correct frequency, the synthesized color subcarrier

frequency can still be adjusted to the required frequency value, by programming the 32 bit of "FSC" under subaddress 63hex to 66hex appropriate. Subcarrier phase reset PHRES in subaddress 70hex has then to be switched off, i.e., set to 00. In general, such an adjustment of "FSC" would produce a non-standard video output signal regarding subcarrier to line phase coupling, comparable to a regular VCR signal. The resulting video signal shows correct subcarrier frequency and (slightly) incorrect raster frequencies. It can be decoded and displayed correctly by any equipment that could handle VCR signals, e.g. by a consumer type television set.

#### 2.4 Remote Genlock

In remote genlock mode the digital encoder runs with the line locked clock LLC, generated by a digital multi standard decoder (DMSD) respectively clock generator (CGC), like SAA7110, SAA7196, SAA7197 or SAA7157. In the decoding process the line locked clock LLC is derived from an analog

video input signal as reference. If this input video signal is not stable or non standard, e.g., a camcorder play back signal, the DMSD will control LLC to stay line locked, which may result into a non-nominal clock frequency. The Philips digital decoder provides an RTC-signal (real time control information) to enable the digital encoder (DENC) to compensate such non-nominal clock, if decoder and encoder are running the same system, i.e., same sampling scheme (CCIR or SQP) and same video norm (field frequency, subcarrier frequency). Decoder LLC and RTCO output signal from DMSD must be connected to LLC and RTCI input signal of DENC. Horizontal and vertical sync signal of both systems can run with phase offset. The data path can have any processing delay, or may be not closed at all.

SAA7187 can be paired for remote genlock operation with the SAA7110, or SAA7191B plus SAA7197, or with SAA7196.

SAA7188A can be paired for remote genlock operation with SAA7151B plus SAA7157.

# Clock and synchronization signals of SAA7187 and SAA7188

## Application note for digital video encoder

### 3.0 RASTER CONTROL OUTPUT SIGNALS

The NTSC / PAL video encoder has an internal synchronization circuitry. For the purpose of this application note it is referred to as horizontal counter – counting in clocks along a horizontal line – and as vertical counter – counting in half lines through a video field. A third counter for color field sequence identification is implemented to support the interlace characteristic of the video signal as well as to distinguish the NTSC four color field sequence, and PAL eight color field sequence. The IC has four Raster Control pins (RCxx), which reflect the timing and status of the internal synchronization circuitry. Two of them carry vertical / field synchronization signals, and two carry horizontal / line synchronization information. One of each pair is output only, the other one can be defined as output or as input, to re-trigger the internal synchronization circuitry. (The nomenclature of these four pins is related to data flow in a particular application, but should not be understood as restriction.) All four signals are defined on one and the same internal synchronization circuitry.

### 3.1 Vertical – Field – Reference Output Signals

The digital encoder SAA7187 and SAA7188A have two pins to output field reference Raster Control signals. RCM1 on pin 29 has output only functionality, and a fixed (nominal) signal polarity. RCV1 on pin 6 has selectable signal polarity and can be used as output or as input to re-trigger internal timing (see later in this application note).

### 3.1.1 Field Reference Signal Types

For both field reference outputs, one signal out of a set of the following three signal types can be selected independently.

**VS** Vertical Sync signal is nominal active (nominal high) for 3 lines if 60Hz timing is selected, or for 2.5 lines if 50Hz timing is selected, i.e., during those half lines, in which the analog CVBS output contains the main vertical sync pulses..

**FS** Frame Sync signal is an odd\_/even signal, that is active (nominal low) during every first i.e. odd field, and inactive (nominal high) during every second, i.e., even field in the 2:1 interlace scheme of two fields in one frame. The first field is that field, in which the first main vertical sync pulse (serration pulse) starts in coincidence with the begin of a line.

**FSEQ** The color Field SEquence signal indicates the start of the color field sequence (see CCIR report 624, e.g.). FSEQ is active (nominal high) during the first field of the 4-(NTSC) or 8-(PAL) color field sequence for standard encoding. FSEQ is inactive (nominal low) through all the other fields.

The position of the output signals VS, FS and FSEQ as RCM1 at pin 29, as well as RCV1 at pin 6, has a fix timing relationship to the internal horizontal and vertical counters and is not directly effected by programming of HTRIG or VTRIG. The leading (nominal

rising) edge of VS, and all edges of FS and FSEQ occur at nominal field start (according to CCIR nomenclature), and on half line boundaries. For standard interlaced mode and nominal field length, FS is low for 262.5 (312.5) lines and high for 262.5 (312.5) lines, for example. The leading (nominal falling) edge of FS or the leading (nominal rising) edge of FSEQ indicates the begin of a frame, the begin of a field, and also the begin of a line, and can be used to reset/trigger external vertical as well as horizontal synchronization counter.

If the encoder is forced into non-interlaced mode through external re-trigger, the FS function is meaningless. If non-standard encoding regarding subcarrier-to-line coupling is applied, selection of FSEQ function is meaningless.

Selecting any of these signal for output as RCM1 on pin 29 or as RCV1 on pin 6 has no direct effect on internal blanking or other processing in the encoder IC itself. RCM1 and RCV1 as output are just auxiliary timing signals for use by the application environment, to support the video signal source (e.g., MPEG decompression circuitry, or video memory controller, or graphics generator) to time its data stream output.

### 3.1.2 Pin 29 : RCM1

Pin 29 RCM1 has output only function and carries field synchronizing raster control information. Via two SRCM bits in subaddress 6Dhex one of three types of field sync signals can be selected.

**Table 2. Selection of RCM1 signal function on Pin 29**

F = relevant function, x = other function/signal definition, - = don't care

BITS UNDER SUBADDRESS 6Dh								BITS UNDER SUBADDRESS 61h								SHORT NAME	FUNCTION RESULTING SIGNAL
7	6	5	4	3	2	1	0	7	6	5	4	3	2	1	0		
								-	x	x	x	x	x	x	F	FISE	select field frequency (V-pulse sequence) select number of clocks/line (selects FSEQ as 4 or 8 field sequence)
-	-	-	-	F	F	x	x									SRCM	select RCM1 signal function
				0	0										0	VS 50Hz	active <b>high</b> for 2.5 lines at begin of every field
				0	0										1	VS 60Hz	active <b>high</b> for 3 lines at begin of every field
				0	1										0	FS 50Hz	<b>low</b> in first (odd) field, 312.5 lines high in second (even) field, 312.5 lines
				0	1										1	FS 60Hz	<b>low</b> in first (odd) field, 262.5 lines high in second (even) field, 262.5 lines
				1	0										0	FSEQ 50Hz	<b>high</b> in the first field of 8 field sequence
				1	0										1	FSEQ 60Hz	<b>high</b> in the first field of 4 field sequence
				1	1										x	n.a.	reserved, do not use

# Clock and synchronization signals of SAA7187 and SAA7188

## Application note for digital video encoder

### 3.1.3 Pin 6 as Output: RCV1

Pin 6 RCV1 can assume output as well as input function and carries field synchronizing raster control information. Via two SRCV1x bits, PRCV1 bit and ORCV1 bit in subaddress 6Chex one of three types of field sync signals can be determined for RCV1 output.

**Table 3. Selection of RCV1 output signal function on pin 6**

F = relevant function, x = other function/signal definition, - = don't care

BITS UNDER SUBADDRESS 6Ch								BITS UNDER SUBADDRESS 61h								SHORT NAME	FUNCTION RESULTING SIGNAL
7	6	5	4	3	2	1	0	7	6	5	4	3	2	1	0		
								-	x	x	x	x	x	x	F	FISE	select field frequency (V-pulse sequence) select number of clocks/line (defines FSEQ as 4 or 8 field sequence)
x	x	x	x	F	x	x	x									PRCV1	Select RCV1 signal polarity
x	x	x	F	x	x	x	x									ORCV1	Input or Output of RCV1 signal
F	F	x	x	x	x	x	x									SRCV1	Select RCV1 signal function
x	x		0	x												-	input RCV1 is input, see Table 6
0	0		1	0												0	VS 50Hz Active <b>high</b> for 2.5 lines at begin of every field
0	0		1	1												0	VS 50Hz Active <b>low</b> for 2.5 lines at begin of every field
0	0		1	0												1	VS 60Hz Active <b>high</b> for 3 lines at begin of every field
0	0		1	1												1	VS 60Hz Active <b>low</b> for 3 lines at begin of every field
0	1		1	0												0	FS 50Hz <b>Low</b> in first ( <b>odd</b> ) field, 312.5 lines <b>High</b> in second ( <b>even</b> ) field, 312.5 lines
0	1		1	1												0	FS 50Hz <b>High</b> in first ( <b>odd</b> ) field, 312.5 lines <b>Low</b> in second ( <b>even</b> ) field, 312.5 lines
0	1		1	0												1	FS 60Hz <b>Low</b> in first ( <b>odd</b> ) field, 262.5 lines <b>High</b> in second ( <b>even</b> ) field, 262.5 lines
0	1		1	1												1	FS 60Hz <b>High</b> in first ( <b>odd</b> ) field, 262.5 lines <b>Low</b> in second ( <b>even</b> ) field, 262.5 lines
1	0		1	0												0	FSEQ 50Hz <b>High</b> in the first field of 8 field sequence
1	0		1	1												0	FSEQ 50Hz <b>Low</b> in the first field of 8 field sequence
1	0		1	0												1	FSEQ 60Hz <b>High</b> in the first field of 4 field sequence
1	0		1	1												1	FSEQ 60Hz <b>Low</b> in the first field of 4 field sequence
1	1	-	-													x	n.a. reserved, do not use

# Clock and synchronization signals of SAA7187 and SAA7188

## Application note for digital video encoder

### 3.2 Horizontal – Line – Reference Output Signals

The digital encoder SAA7187 and SAA7188A have two pins to output line reference Raster Control signals. RCM2 on pin 30 has output only functionality, and a fixed (nominal) signal polarity. RCV2 on pin 7 has selectable signal polarity and can be used as output, or as trigger input to re-synchronize internal timing, or as 'blanking' input to gate input data stream (see later in this application note).

Both horizontal raster control output signals can be freely defined along the line, and are active (nominal high) between "begin" and "end" (see Table 4). Begin and end can be chosen independently for RCM2 and RCV2. Both pairs are relative to the same internal horizontal counter, and are defined in LLC clocks. The internal horizontal counter manifests its timing in the analog output, and can depend on re-trigger via RCV1 or RCV2 input signals and programming of HTRIG under subaddress 6Ehex and 6Fhex (see later in this application note).

RCM2 and RCV2 as output are auxiliary timing signals for use by the application environment, e.g., to help the data source (MPEG decompression circuitry, video memory controller or graphics overlay generator) to time its data stream, or disable it. The programming of RCM2 and RCV2 as output does not effect internal blanking, data enabling, or any timing or processing in the encoder IC itself.

#### 3.2.1 Pin 30: RCM2

Pin 30 RCM2 has output only function. RCM2 is active high between 'Begin = BMRQ' and 'End = EMRQ' in every line, i.e., also during vertical blanking interval VBI. Programming of FAL and LAL has no effect on RCM2. If End is programmed before (i.e., with a lower number than) Begin, RCM2 may be seen/understood as an active low signal between End and Begin.

#### 3.2.2 Pin 7 as Output : RCV2

Pin 7 RCV2 can assume output as well as input function (see Tables 3, 4, and 5).

Program bit ORCV2 = 1 defines pin 7 for RCV2 output signal. RCV2 output is active (nominal high) from programmed 'Begin = BRCV' to 'End = ERCV'. The polarity is defined by program bit PRCV2.

Program bit CBLF defines whether RCV2 output is active in every line (CBLF = 0), regardless of vertical position, or whether RCV2 output is only active during selected vertical active range (CBLF = 1). Vertical active range is defined between 'first active line' FAL and 'last active line' LAL under subaddress 7Bhex to 7Dhex. By that, RCV2 as output signal could be used as horizontal line timing reference signal ("HREF") or as composite blanking signal ("CBN"), to enable data output at the video signal source. But if pin 7 is programmed as RCV2 output signal, its signal and related programming has no effect for any timing, blanking, data enabling or processing in the encoder IC itself. FAL and LAL defines internal vertical blanking, independently of whether CBLF is selecting it for gating of RCV2 output or not.

Table 4. Definition of output timing of RCM2 (pin 30) and RCV2 (pin 7)

PROGRAM WORD	11 BIT ADDRESS IN HORIZONTAL DIRECTION LLC RESOLUTION	RCM2 PIN30 OUTPUT ONLY	RCV2 PIN7 ONLY IF OUTPUT
BRMQ	subaddress 71hex, 73hex	L-to-H transition, rising edge	
ERMQ	subaddress 72hex, 73hex	H-to-L transition, falling edge	
BRMQ	subaddress 77hex, 79hex		begin of 'active' phase
ERMQ	subaddress 78hex, 79hex		end of 'active' phase

Table 5. Selection of RCV2 output signal function on pin 7

F = relevant function, x = other function/signal definition, - = don't care

BITS IN SUBADDRESS 6Chex								SHORT NAME	FUNCTION DESCRIPTION
7	6	5	4	3	2	1	0		
x	x	x	x	x	x	x	F	PRCV2	Polarity of RCV2
x	x	x	x	x	x	F	x	ORCV2	I/O of RCV2
x	x	x	x	x	F	x	x	CBLF	RCV2 in VBI (see FAL and LAL)
					x	0	x	input	RVC2 is input, see Table 7
					0	1	0	"HREF"	RCV2 output is active high between BRCV till ERCV in every line of the entire field, i.e., including VBI
					0	1	1	"HREF_"	RCV2 output is active low between BRCV till ERCV in every line of the entire field, i.e., including VBI
					1	1	0	"CBN"	RCV2 output is active high between BRCV till ERCV in active lines only from FAL to LAL, i.e., excluding VBI
					1	1	1	"CB"	RCV2 output is active low between BRCV till ERCV in active lines only from FAL to LAL, i.e., excluding VBI

## Clock and synchronization signals of SAA7187 and SAA7188

### Application note for digital video encoder

#### 4.0 RASTER CONTROL INPUT SIGNALS, SYNC-SLAVE-MODE

The internal synchronization circuitry of the digital encoder SAA7187 and SAA7188A are always defined by FISE (number of clocks per line, subaddress 61hex), FLEN (number of lines per field, subaddress 7Ahex and 7Dhex), and PAL (defining color field sequence length, subaddress 61hex). In sync slave mode, those horizontal and vertical counters can be re-triggered by an external trigger event at pin 6 as RCV1 input and/or at pin 7 as RCV2 input. The rising or falling edge can be selected as timing reference (trigger event) to re-synchronize the internal synchronization circuitry, regarding horizontal or vertical counter, or odd-even flip-flop, or color field sequence counter. As long as no trigger event occurs the internal counters are free running in the defined loops. Any single occurrence of the selected edge in RCV1 or RCV2 input will hard re-trigger — i.e., it is not

a smoothed PLL procedure. Due to processing pipeline delay, the resulting re-synchronization does not take effect before the next following corresponding period. A programmable vertical and horizontal trigger offset can be applied via VTRIG and HTRIG.

RCV2 as input can also optionally be used as "composite blanking" signal to gate the input data stream, but only for data coming through V-port (and D-port).

VTRIG represents a negative delay between external trigger event and internal vertical counter start, i.e., start of main vertical sync (serration) pulses. The external re-synchronization event at RCV1 over-writes the vertical counter state with VTRIG value, which then synchronizes the next vertical period to the external trigger signal. VTRIG is defined with 5 bits under subaddress 70 hex. The programmed VTRIG number corresponds with the position of the

external trigger event along the field, counted in half lines. Programming 00 will synchronize the internal vertical counter to generate vertical sync at the begin of that same half line, in which the external trigger event occurs. Programming of 1F hex results in vertical sync output 31 half lines ahead of the external trigger input, for example.

HTRIG represents a negative delay between external trigger event and internal horizontal counter start, i.e., leading edge of horizontal sync pulse. The external re-synchronization event at RCV1 or RCV2 over-writes the horizontal counter state with HTRIG value, which then synchronizes the next horizontal period to the external trigger signal. HTRIG is defined with 11 bits under subaddresses 6E hex and 6F hex in LLC clock resolution, and covers the whole line period. The programmed HTRIG number corresponds with its position (in LLC clocks) along the scan line.



# Clock and synchronization signals of SAA7187 and SAA7188

## Application note for digital video encoder

### 4.1 Pin 6 as Input: RCV1

If pin 6 is selected as input, RCV1 signal could carry field synchronization information in a form like vertical sync VS, or frame sync FS, or field sequence identification FSEQ. The actual re-trigger function of RCV1 input is defined via the two SRCV1 bits, TRCV2 bit, ORCV1 bit and PRCV1 bit, all in subaddress 6Chex, and the PAL bit in subaddress 61hex. Table 6 describes signal meaning and effect of RCV1 as input at pin 6.

**Table 6. Selection of RCV1 input signal function on pin 6**

F = relevant function, x = other function/signal definition, - = don't care

BITS UNDER SUBADDRESS 6Ch								BITS UNDER SUBADDRESS 61h								SHORT NAME	RCV1 INPUT PIN 6	FUNCTION: Active edge results in retrigger of following counters:						
7	6	5	4	3	2	1	0	7	6	5	4	3	2	1	0			HORIZONTAL	VERTICAL	ODDEVEN	COLOR FIELD SEQ			
0	0	0	0	0	0										x	VS	rising	horizontal	vertical	(n-interl.)				
0	0	0	0	0	1											x	VS	falling	horizontal	vertical	(n-interl.)			
0	0	1	0	0												x	VS	rising		vertical				
0	0	1	0	1												x	VS	falling		vertical				
0	1	0	0	0												x	FS	rising	horizontal	vertical	odd field			
0	1	0	0	1												x	FS	falling	horizontal	vertical	odd field			
0	1	1	0	0												x	FS	rising		vertical	odd field			
0	1	1	0	1												x	FS	falling		vertical	odd field			
1	0	0	0	0											0	FSEQ8	rising	horizontal	vertical	odd field	1st of 8 fields			
1	0	0	0	1											0	FSEQ8	falling	horizontal	vertical	odd field	1st of 8 fields			
1	0	1	0	0											0	FSEQ8	rising		vertical	odd field	1st of 8 fields			
1	0	1	0	1											0	FSEQ8	falling		vertical	odd field	1st of 8 fields			
1	0	0	0	0											1	FSEQ4	rising	horizontal	vertical	odd field	1st of 8 fields			
1	0	0	0	1											1	FSEQ4	falling	horizontal	vertical	odd field	1st of 8 fields			
1	0	1	0	0											1	FSEQ4	rising		vertical	odd field	1st of 8 fields			
1	1	1	0	1											1	FSEQ4	falling		vertical	odd field	1st of 8 fields			
1	1	x	x	x											x	n.a		reserved, do not use						
x	x	x	1	x											x	n.a.	output	RCV1 is output, see Table 3						
															-	x	x	x	x	x	x	F	FISE	Select field frequency (V-pulse sequence) select clocks per line defines FSEQ as 4 or 8 field sequence
x	x	x	x	F	x	x	x										PRCV1	Select RCV1 signal polarity						
x	x	x	F	x	x	x	x										ORCV1	Input or Output of RCV1 signal						
x	x	F	x	x	x	x	x										TRCV2	RCV1 or RCV2 for horizontal trigger						
F	F	x	x	x	x	x	x										SRCV1	Select RCV1 signal function						

# Clock and synchronization signals of SAA7187 and SAA7188

## Application note for digital video encoder

### 4.2 Pin 7 as Input: RCV2

If pin 7 is selected as input, RCV2 signal can carry just line synchronization information like horizontal sync HS, or input data gating function like HREF or CBN. The horizontal re-trigger function and the data input gating function can be utilized seoarately, or they combined. The actual function of RCV2 input is defined via the CBLF bit, ORCV2 bit, PRCV2 bit and TRCV2 bit, all in subaddress 6Chex. Table 7 describes signal meaning and effect of RCV1 as input at pin 6.

**Table 7. Selection of RCV2 input signal function on pin 7**

("x" defines other functions/signals)

BITS IN SUBADDRESS 6Chex							SHORT NAME	RCV2 INPUT	FUNCTION DESCRIPTION
7	6	5	4	3	2	1		0	
							F	PRCV2	Polarity of RCV2
							F	ORCV2	I/O of RCV2
					F			CBLF	RCV2 in VBI (see FAL and LAL)
	F							TRCV2	Select horizontal trigger from RCV1/2
	0			0	0		-	any input	but not used for re-trigger or gating
	0			1	0	0		input high input low	enable V-port data input for encoding disable V-port data input for encoding
	0			1	0	1		input low input high	enable V-port data input for encoding disable V-port data input for encoding
	1			0	0	0		rising edge	horizontal re-trigger, with HTRIG
	1			0	0	1		falling edge	horizontal re-trigger, with HTRIG
	1			1	0	0		rising edge input high input low	horizontal re-trigger, with HTRIG disable V-port data input for encoding enable V-port data input for encoding
	1			1	0	1		falling edge input low input high	horizontal re-trigger, with HTRIG disable V-port data input for encoding enable V-port data input for encoding
	x			x	1	x		output	RCV2 is output, see Table 5

# Clock and synchronization signals of SAA7187 and SAA7188

## Application note for digital video encoder

### 5.0 SYNC TIMING DEPENDENCIES

The selected "active" edge of the external timing reference signal RCV1 or RCV2 loads the internal horizontal counter with the HTRIG value. At the end of the line the counter is automatically reset, and all timing signals are in phase with the requesting re-trigger. This horizontal counter also defines the begin and end points of the raster control output signals.

The effect of VTRIG for vertical synchronization timing is very similar.

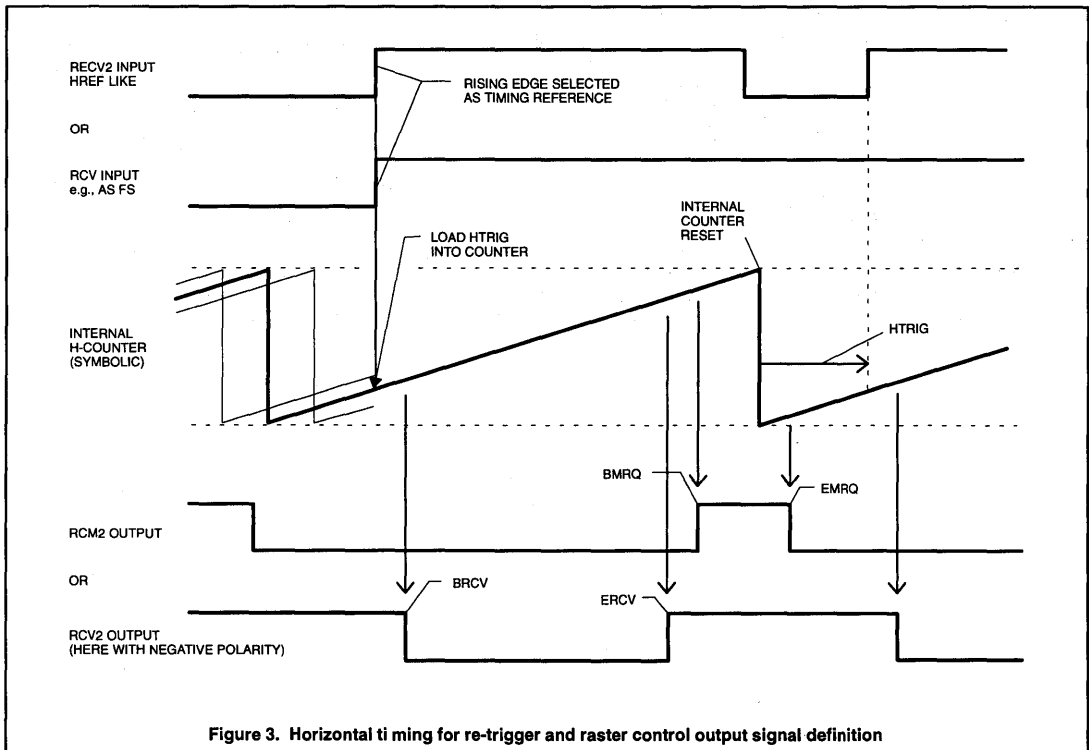

## Clock and synchronization signals of SAA7187 and SAA7188

### Application note for digital video encoder

#### 6.0 APPLICATION EXAMPLE

Figure 4 points out several of those features that can be realized in an application with SAA7188A (or SAA7187). Two or more digital video encoder devices can be locked to each other. All their analog video outputs are completely in phase: horizontally, vertically and also the subcarrier. One of the devices functions as timing master, the other ones work in sync slave mode. The master device provides on RCM1 the color field sequence indication signal FSEQ, which transports horizontal and vertical reference as well as subcarrier phase reference via the color field sequence indication. The RCV1 inputs of the other devices are set to FSEQ function and also used to trigger line timing. VTRIG and HTRIG are both set to zero.

RCM2 output of the master device can be freely defined in horizontal timing. By that it can be used as input data gating signal (HREF-gate) at the RCV2 inputs of the other encoder devices. This RCM2 output signal of the master device (or of each device) could also be fed back to its own RCV2 input for input data gating function.

RCM1 and RCM2 outputs of the slave devices can be used as trigger and timing signals for the digital video signal sources.

RCM1 can be chosen as a vertical sync, or as an odd/even signal. RCM2 can be defined as an HS for trigger and counting purposes, or it can be used as a source gating signal. It can be placed 'early' to compensate for pipeline delay on the data delivery side, such as memory access, etc.

If the RCV2 pins of the slave (and/or the master) device are not used as gating input, they could be switched to output, and could be used as (early) enabling signal (CBN) at the signal source. In that case even VBI blanking is supported. (This option is not shown in Figure 4).

The digital encoder that works as timing master in the configuration of Figure 4 can be genlocked to an analog video reference signal via digital encoder circuitry. For this purpose, the SAA7188A can be combined with the SAA7151B, SAA7157 and TDA8708/09. The SAA7187 can be combined with the SAA7191B, SAA7197 and TDA8708/09 or with the SAA7110. The digital real-time decoder system locks itself to the analog reference video signal and generates line-locked clock, horizontal and vertical sync signals, and the real-time control signal RTC. If the encoder runs with the line-locked clock of the decoder, it is important to also have the

RTC wire connected, in order to maintain the correct subcarrier frequency in the encoder, same as in the analog reference signal. To have the same clock at both the decoder and encoder side is very interesting in some applications; for example, as a frame buffer as it avoids the complications of an asynchronous two-clock system.

The SAA7151B or other decoder can provide a pair of vertical and horizontal syncs as VS and HS, or provide an odd/even signal FS ("ODD" on pin 39 of SAA7151B, for example) to synchronize the digital encoder to the reference video signal, and also into the correct interlace sequence. Proper programming of HTRIG and VTRIG can adjust pipeline processing delay in decoder and/or frame buffer circuitry. If FS from the decoder is used as RCV1 input for the first "master" encoder, it can also be utilized as a horizontal reference signal. Then RCV2 is free to be used as gating input, fed by the RCM2 output, or it can be switched to output a CBN-like signal to one of the video signal sources.

Figure 4 shows a rather complex system, but the various timing techniques, as discussed above, can be applied in simpler systems, too.

# Clock and synchronization signals of SAA7187 and SAA7188

## Application note for digital video encoder

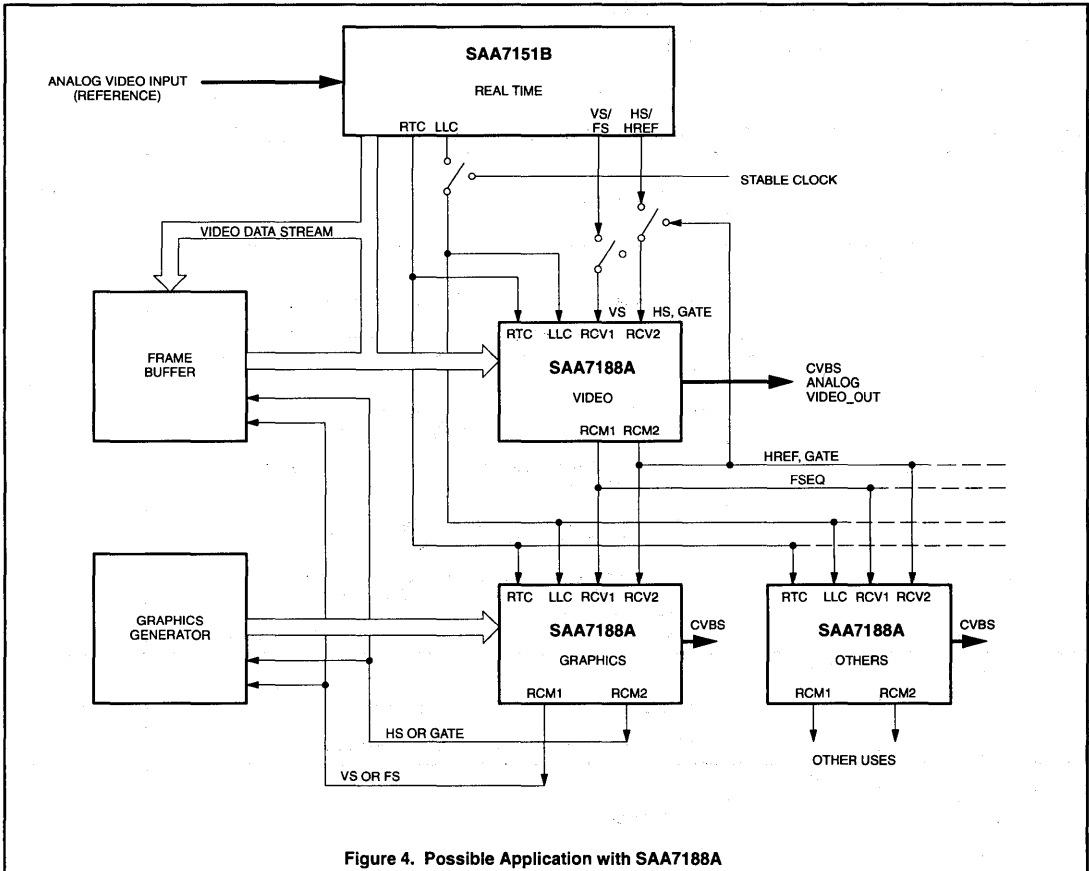

Figure 4. Possible Application with SAA7188A

# Clock and synchronization signals of SAA7187 and SAA7188

## Application note for digital video encoder

### 7.0 APPENDIX: SOME PROGRAMMING TABLES

#### 7.1 Synchronization Signals (6C, 6D, 70)

##### 7.1.1 Subaddress 6C hex

Table 8. Program for RCV1 and RCV2 function at pin 6 and pin 7 in subaddress 6C-hex

BITS IN SUBADDRESS 6C hex								SHORT NAME	FUNCTION DESCRIPTION	DEFAULT AFTER RESET
7	6	5	4	3	2	1	0			
							0	PRCV2	RCV2 is active high, rising edge is timing reference	0
							1		RCV2 is active low, falling edge is timing reference	
						0	0	SRVC2	CBLF & ORCV2	00
						0	1		RCV2 is input, has no input data gating function, but can be used for horizontal re-trigger, see TRCV2	
						1	0		RCV2 is output, horizontal (timing) reference signal in all lines, begin and end freely programmable by BRCV and ERCV	
						1	1		RCV2 is input, and has input data gating function, can also be used for horizontal re-trigger, see TRCV2	
								PRCV1	RCV1 is active high, rising edge is timing reference	0
							0		RCV1 is active low, falling edge is timing reference	
								ORCV1	RCV1 is input	0
							0		RCV1 is input	
								TRCV2	Horizontal re-trigger by RCV1, RCV1 must be input	0
							0		Horizontal re-trigger by RCV2, RCV2 must be input	
								SRCV1	VS (vertical sync), every field	00
							0		FS (frame sync), odd_/even	
							1		FSEQ color field sequence indication	
							1		n.a.; don't use this combination	
0	0	0	0	0	0	0	0	00 hex	default after reset IC is prepared to accept an odd_/even signal at RCV1 (rising edge at begin of first field)	0000 0000

# Clock and synchronization signals of SAA7187 and SAA7188

## Application note for digital video encoder

### 7.1.2 Subaddress 6D hex

**Table 9. Program for RCM1 at pin 29 and "Line 21" encoding in subaddress 6D-hex**

BITS IN SUBADDRESS 6Dhex								SHORT NAME	FUNCTION DESCRIPTION
7	6	5	4	3	2	1	0		
						0	0	CCEN	"Line 21" encoding, Closed Caption and Extended Data service no "line 21" encoding in either field
						0	1		"Line 21" encoding in first (odd) field only (extended data), data content as programmed in subaddress 69hex and 6Ahex
						1	0		"Line 21" encoding in second (even) field only (Closed Caption), data content as programmed in subaddress 67hex and 68hex
						1	1		"Line 21" encoding in both fields
				0	0			SRCM	select type of field reference output signal on pin 29 RCM1
				0	1				VS (vertical sync), active high during serration pulses (3 or 2.5 lines)
				1	0				FS (frame sync), active low during odd field, high during even field
				1	1				FSEQ color (field sequence indication signal), active high during first field of four fields, if FISE = 1 (60 Hz, 525 lines) first field of eight fields, if FISE = 0 (50 Hz, 625 lines)
0	0	0	0						reserved

### 7.1.3 Subaddress 70 hex

**Table 10. Program for VTRIG and VBI (vertical blanking interval) in subaddress 70-hex**

BITS IN SUBADDRESS 70hex								SHORT NAME	FUNCTION DESCRIPTION
7	6	5	4	3	2	1	0		
			x	x	x	x	x	VTRIG	vertical trigger phase offset half line number, in which vertical/field trigger input occurs
		0						SBLBN	Vertical Blanking Interval (VBI) blanking is enforced in all lines outside FAL-to-LAL, (First Active Line to Last Active Line, see subaddress 7B, 7C, and 7D)
		1							blanking is only enforced only during equalization and serration (vertical sync) pulses, i.e., 9 (60Hz) or 7.5 (50Hz) lines, signal insertion a/o encoding also outside FAL-to-LAL, allowing data, time code or test signal insertion in regular VBI
0	0							PHRES	color subcarrier reset mode, to support SC-H coupling
0	1								continuously running color subcarrier oscillation, e.g., for remote genlock RTC mode
1	0								color subcarrier phase reset every second line
1	1								color subcarrier phase reset every eighth field (PAL) color subcarrier phase reset every fourth field (NTSC)

# Clock and synchronization signals of SAA7187 and SAA7188

## Application note for digital video encoder

### 7.2 Video Standard Parameters (61, 70, 60)

#### 7.2.1 Subaddress 60 hex

Table 11. Basic video standard parameters in subaddress 61-hex

BITS IN SUBADDRESS 61-hex								SHORT NAME	FUNCTION DESCRIPTION	DEFAULT AFTER RESET
7	6	5	4	3	2	1	0			
							0	FISE	field frequency mode select	1
							1		50 Hz, 312.5 lines per field, 5 V-sync serration pulses etc, (start pre-equalization pulses 310 lines after field start) 864 (CCIR) pixels per line, i.e., 1778 LLC, 13.5 MHz 944 (SQP) pixels per line, i.e., 1888 LLC, 14.75 MHz FSEQ generates 4 field sequence	
							0	PAL	switch of subcarrier phase for V-component in alternative lines	0
							1		no color subcarrier phase toggle switch, for NTSC encoding  PAL-switch, i.e., subcarrier phase switch ( $\pm 45^\circ$ toggle) for V-color component in alternative lines, for PAL encoding	
							0	SCBW	chrominance bandwidth	1
							1		extended chrominance bandwidth, e.g., option for S-video output  standard chrominance bandwidth	
							0	RTCE	Real Time Control enable	0
							1		no Real Time Control applied, standard subcarrier generation, relies on clock LLC stability  Real Time Control of subcarrier frequency generation, RTC connection from appropriate Philips decoder needed	
			0					YGS	luminance gain select	1
			1						luminance (black to white) is adjusted to 100 IRE  luminance (black to white) is adjusted to 92.5 IRE, giving room for 7.5 IRE setup, e.g., for NTSC	
			0					INPI	PAL switch phase	0
			1						nominal (standard) phase of PAL-switch  opposite to standard, e.g., to adjust pipeline delay in RTC mode	
			0					DOWN	analog output (DACs)	0
			1						DACs in normal operation, analog output of encoded video signal  DACs are switched to lowest output voltage	
0									reserved	0
0	0	0	1	0	1	0	1	15 hex	default after reset	0001 0101



# Clock and synchronization signals of SAA7187 and SAA7188

## Application note for digital video encoder

### 7.2.2 Subaddress 70 hex

**Table 12. Program for subcarrier phase reset (SC-H) in subaddress 70-hex**

BITS IN SUBADDRESS 70hex								SHORT NAME	FUNCTION DESCRIPTION
7	6	5	4	3	2	1	0		
			x	x	x	x	x	VTRIG	vertical trigger phase offset half line number, in which vertical/field trigger input occurs
		0						SBLBN	Vertical Blanking Interval (VBI) blanking is enforced in all lines outside FAL-to-LAL, (First Active Line to Last Active Line, see subaddress 7B, 7C, and 7D)
		1							blanking is only enforced only during equalization and serration (vertical sync) pulses, i.e., 9 (60Hz) or 7.5 (50Hz) lines, signal insertion a/o encoding also outside FAL-to-LAL, e.g., data, time code or test signal insertion in regular VBI
0	0							PHRES	color subcarrier reset mode, to support SC-H coupling
0	1								continuously running color subcarrier oscillation, e.g., for remote genlock RTC mode
1	0								color subcarrier phase reset every second line
1	1								color subcarrier phase reset every eighth field (PAL) color subcarrier phase reset every fourth field (NTSC)

### 7.2.3 Subaddress 60 hex

**Table 13. Program for cross color reduction in analog CVBS-out under subaddress 60-hex**

BITS IN SUBADDRESS 60hex								SHORT NAME	FUNCTION DESCRIPTION
7	6	5	4	3	2	1	0		
		0	0	0	0	0	0		reserved
								CCRS	Cross Color Reduction, reducing cross talk from luminance into chrominance as support for the testation receiver / decoder filter are active only from FAL-to-LAL, i.e., active video
0	0								standard CVBS, straight addition of luminance and chrominance signals
0	1								notch filter at 4.5 Mhz in luminance signal before adding chrominance, e.g., for PAL color subcarrier or NTSC sound carrier
1	0								notch filter at 3.3 Mhz in luminance signal before adding chrominance, wide and deep, e.g., for NTSC color subcarrier
1	1							notch filter at 3.3 Mhz in luminance signal before adding chrominance, more narrow than other one, e.g., for NTSC color subcarrier	

# Clock and synchronization signals of SAA7187 and SAA7188

## Application note for digital video encoder

### 7.3 Input Data Format and Signal Flow (3A, 6B)

#### 7.3.1 Subaddress 3A hex, SAA7188A only

**Table 14. Program for input data de-formatting in subaddress 3A-hex**

BITS IN SUBADDRESS 3A-hex								BIT NAME	FUNCTION DESCRIPTION	DEFAULT AFTER RESET
7	6	5	4	3	2	1	0			
							0	MUV2C	(M-port chroma two's complement)	1
							1		Cb-Cr data at M-port is expected in two's complement Cb-Cr data at M-port is expected in offset binary (acc. to CCIR 656)	
							0	MY2C	(M-port luminance two's complement)	1
							1		Y data at M-port is expected in two's complement around medium gray Y data at M-port is expected in straight binary (acc. to CCIR 656)	
							0	VUV2C	(V/D-port chroma two's complement)	0
							1		Cb-Cr data at V/D-port is expected in two's complement (compare DTV-mode of SAA7151B) Cb-Cr data at V/D-port is expected in offset binary (CCIR-mode)	
							0	VY2C	(V-port luminance two's complement)	0
							1		Y data at V-port is expected in two's complement around medium gray Y data at V-port is expected in straight binary (CCIR- and DTV-mode)	
			0					V656	data format at V-port and D-port	1
			1						16 bit YUV interface formed by V-port = Y & D-port = UV 8-bit wide CCIR656 compatible data format at V-port	
	0	0							reserved	00
	0							CBENB	internal color bar test signal switch	0
	1								normal encoding of input data color bar test signal via encoding of LUT values	
0	0	0	1	0	0	1	1	13 hex	default after reset	0001 0011

#### 7.3.2 Subaddress 6B hex, SAA7188A only

**Table 15. Program for input data selection in subaddress 6B-hex**

BITS IN SUBADDRESS 6B-hex								SEL_ED Pin 18	BIT NAME FUNCTION DESCRIPTION
7	6	5	4	3	2	1	0		
									MODIN - defines data from which port gets encoded
0	0							-	data from M-port gets encoded
0	1							1	data from M-port gets encoded
0	1							0	data from V(D)-port gets encoded
1	0							-	data from V(D)-port gets encoded
1	1							1	data from V(D)-port gets encoded
1	1							0	data from M-port gets encoded
		0	x	x	x	x	x		other function: line number for closed caption encoding

# Clock and synchronization signals of SAA7187 and SAA7188

## Application note for digital video encoder

### 7.4 Input Data Formats (subaddress 3A), SAA7187 only

#### 7.4.1 Subaddress 3A hex, SAA7187 only

**Table 16. Program for input data de-formatting in subaddress 3A-hex**

BITS IN SUBADDRESS 3A-hex								BIT NAME	FUNCTION DESCRIPTION	DEFAULT AFTER RESET
7	6	5	4	3	2	1	0			
						0	0	FMT	Input Data Formats	00
						0	1		YUV 4:4:4 on 24 pins, Y on VP1, V=Cr on VP2, U=Cb on VP3	
						1	0		YUV 4:2:2 on 16 pins, Y on VP1, U=Cb and V=Cr multipexed on VP3	
						1	1		YUV 4:2:2 on 8 pins, on VP1, multipexed according to CCIR-656 reserved	
						0		VUVC	chroma two's complement	0
						1			Cb-Cr input data is expected in two's complement Cb-Cr input data is expected in offset binary (CCIR-mode)	
						0		VY2C	luminance two's complement	0
						1			Y data at V-port is expected in two's complement around medium gray Y data at V-port is expected in straight binary (CCIR- and DTV-mode)	
0	0	0	0						reserved	000
0								CBENB	internal color bar test signal switch	0
1									normal encoding of input data color bar test signal via encoding of LUT values	
0	0	0	0	0	0	0	0		00 hex default after reset	0000 0000

## Evaluation board for SAA7188A encoder

## DTV7188A

Author: George Ellis

## OVERVIEW

The Philips SAA7188A digital video encoder has been developed to address the consumer and set-top converter market. This device offers an excellent ratio of performance to cost. It has a highly programmable feature set designed for flexible interfacing in a variety of environments. The following application board information is provided to aid customers in the development of their products.

## BOARD FEATURES

The evaluation board consists of three major sections:

- An input section consisting of:
  - A dual converter which will digitize both S-Video and composite video (replacing the TDA8708A and TDA8709A parts). This device is the TDA8758.
  - The SAA7152 digital adaptive comb filter.
  - The SAA7151B, CCIR601-based, multistandard digital video decoder.
  - The SAA7197 clock generator.
- An interface section consisting of:
  - ECL to TTL translators for converting CCIR656 (D1) data to TTL levels.
  - A PLD device to extract the sync timing information from the D1 video data.
- The encoding section, consisting of:
  - SAA7188A digital video encoder.
  - A n S87C055 microcontroller for programming the system and providing on-screen display.
  - A PCF8598 EEPROM to allow the user to save custom settings.

Ancillary TTL, voltage regulation and filtering components are provided to complete the functionality of the evaluation board.

The system can be configured for a variety of operational modes.

- Composite or S-Video can be digitized and decoded and this data, clocks and sync information used to operate the encoder in RTC remote genlock mode. This is called DTV mode.
- D1 (CCIR656) video data can be input from a digital generator. The sync timing is

decoded from the video data stream and used to drive the encoder in slave mode.

- The encoder can receive clock information from a server (such as an MPEG decoder) and provide handshake information (HREF and VERT) to download data from the server.
- The SAA7188A can be run in Master mode providing clock and sync timing to other slave devices.

## Input Section

Either composite or S-Video can be selected to be digitized by the TDA8758. The input selection of the A/D converter is controlled by programming the SEL pins with the general purpose switches on the decoder (GPSW1 and GPSW2).

The digitized video is then routed to the SAA7152 comb filter, which, in the case of composite video, separates the data into luminance and chrominance data. In the case of S-Video, the comb filter is bypassed in software. The comb filter can be removed entirely and bypassed at JP5 with jumpers.

The SAA7151B, in conjunction with the SAA7197 (or SAA7157), decodes the chroma into baseband U and V, performs luminance processing and generates the clock and sync signals.

## D1 Interface Section

As an alternative to digital video from the SAA7151B input section (DTV mode), the board will accept CCIR656 (D1) input. Being that D1 is an ECL data format, ECL to TTL conversion will be necessary (a negative 9 volt supply is also required).

Selection between the two video inputs is as follows:

For video from the SAA7151B (DTV mode), jumpers are installed onto JP1 (except across pins 55–56 and 57–58. Jumper JP3 is not connected.

To select D1 video, remove JP1 jumpers from pins 39 to 60 and install a shunt to JP3.

Devices U2, U3, and U4 translate the ECL data and clock into TTL. U1 then decodes the TTL data to extract HREF, Vert. Sync. and Field ID to synchronize the encoder.

## The Encoder Section

The SAA7188A has three 8 bit data ports. For this application, the MP port, which is a multiplexed YCbCr port, is used to receive the D1 data stream. the VP port is used to receive the Y portion of the SAA7151B data stream and the CP port receives the UV (CbCr) portion. Selection between the two inputs is done using the SEL\_ED pin, controlled via a port from the microcontroller (P2.0). The VP/CP port is set to 16 bit mode by I<sup>2</sup>C programming.

In the D1 mode, clock (ENC\_LLC), Data (on the MP port), HREF (ENC\_HREF), field ID (ENC\_FI) are all that is needed to drive the SAA7188A.

In the DTV mode, the 16 bit YUV data stream is used, along with ENC\_LLC, ENC\_CREF, ENC\_HREF, ENC\_FI and ENC\_RTC. All derived via JP1.

**NOTE:** In both modes, the CDIR is set to select the clocks as INPUTS. CDIR is controlled by port P2.1 of the microcontroller.

Other interfacing modes are available, CDIR can be set to select that the SAA7188A function as a clock MASTER. The signals RCV1 and RCV2 can be set to be either INPUTS for external H and V synchronization, or they can be configured as OUTPUTS. As inputs, the reset point can be offset with programming. As outputs, the position can be programmed with respect to the internal H and V origins.

This allows for a wide variety of handshaking with various data servers, such as MPEG decoders, graphic systems, FIFOs, etc.

Use the jumpers selections at JP1 and JP3 to avoid configuration conflicts.

Anti-aliasing filters are suggested on the output, however, because the SAA7188A is twice over-sampled, these filters can be simple. The filters shown here are inexpensive and provide some  $\sin(x)/x$  compensation.

External I<sup>2</sup>C control is available by interfacing to JP2.

The PLD source for the EOV-SOV decoder, U1 is provided; it is done under the SNAP programming format.

A sample programming example is also provided in Section 3, following the data sheet.

Evaluation board for SAA7188A encoder

DTV7188A

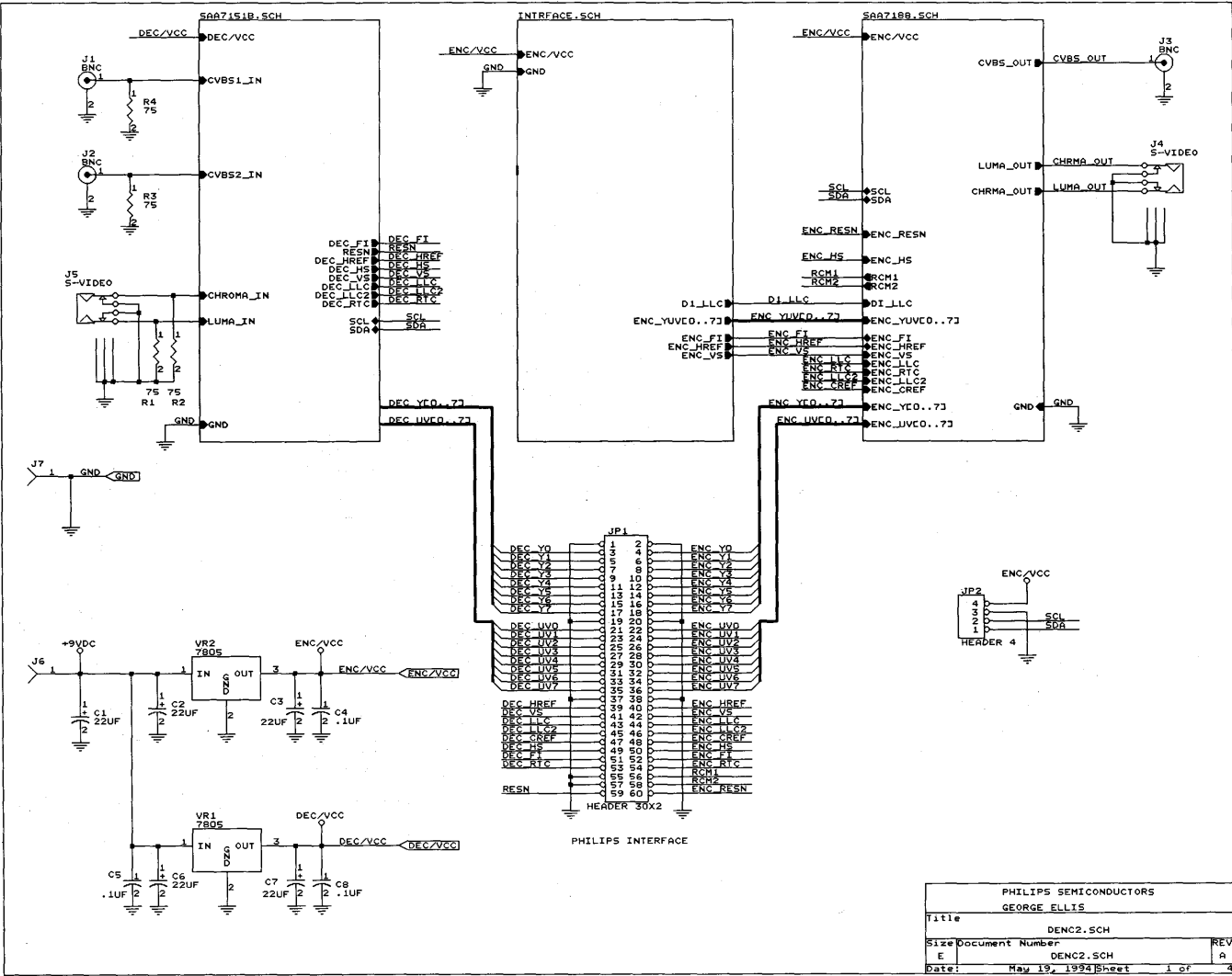

PHILIPS SEMICONDUCTORS	
GEORGE ELLIS	
Title	DENC2.SCH
Size Document Number	REV
E	DENC2.SCH
Date:	May 19, 1994 Sheet 1 of 4

Evaluation board for SAA7188A encoder

DTV7188A

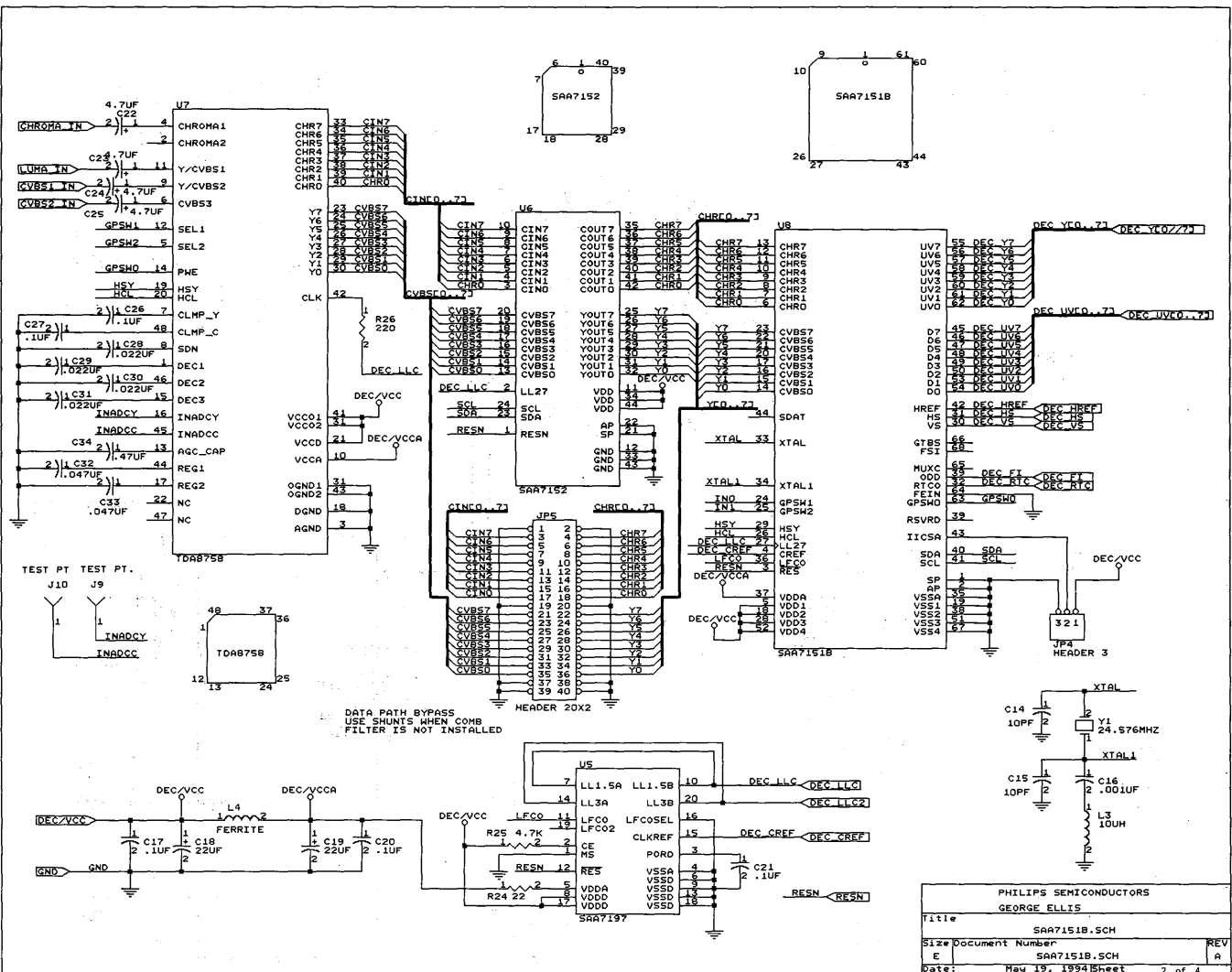

Evaluation board for SAA7188A encoder

DTV7188A

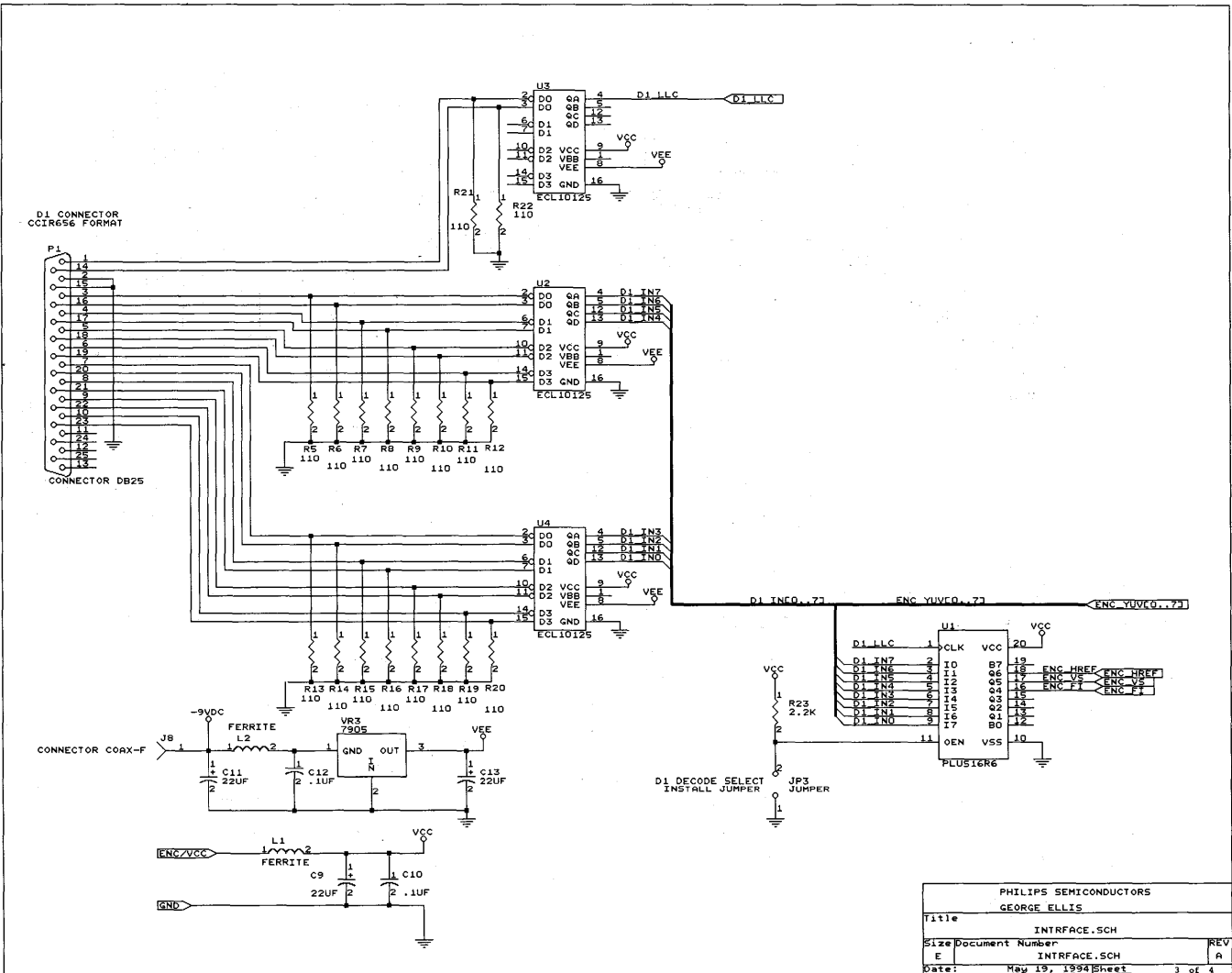

Evaluation board for SAA7188A encoder

DTV7188A

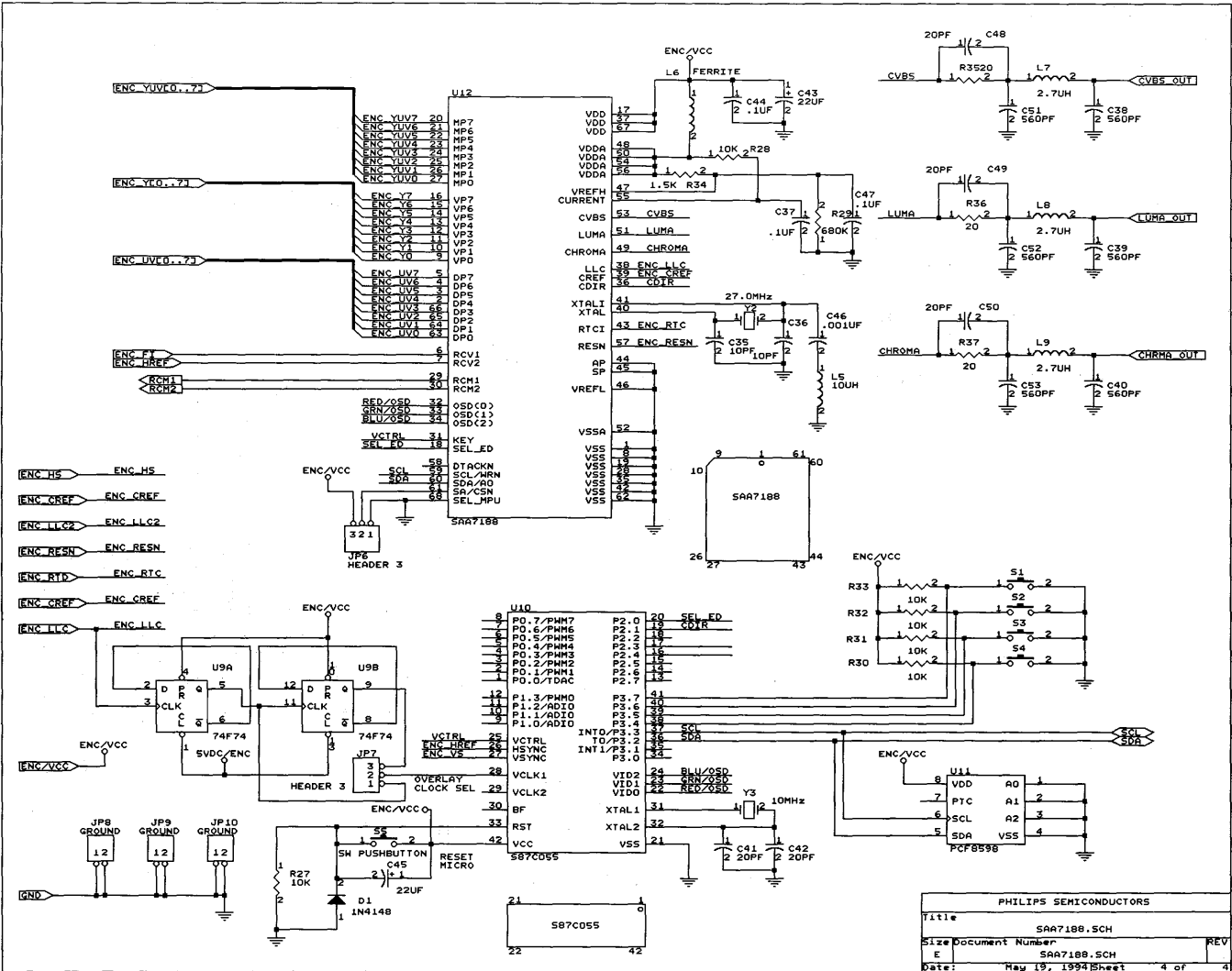

PHILIPS SEMICONDUCTORS			
Title	SAA7188A.SCH	REV	
Size Document Number	SAA7188A.SCH	REV	
E	SAA7188A.SCH	REV	
Date:	May 19, 1994	Sheet	4 of 4



## Evaluation board for SAA7188A encoder

DTV7188A

```
      " D1 EOVS-SOV-decoder for synchronization signals      "
@PINLIST
INPUT[7..0] I ;
CLK          I ;
HREF        O;
VBLK        O;
FID         O;

@GROUPS
@TRUTHTABLE
@LOGIC EQUATIONS
CODE[3..1] .CLK = CLK ;
CODE1.D    = INPUT[7..0] == FFH ;
CODE2.D    = INPUT[7..0] == 00H ;
CODE3.D    = INPUT[7..0] == 00H ;
LOOK       = CODE1 * CODE2 * CODE3 ;

FID.D      = LOOK * INPUT6 +
            /LOOK * FID    ;
FID.CLK    = CLK ;

VBLK.D     = INPUT5 * LOOK +
            /LOOK * VBLK  ;
VBLK.CLK   = CLK ;

HREF.D     = INPUT4 * LOOK
            + /LOOK * HREF ;
HREF.CLK   = CLK ;

@INPUT VECTORS
@OUTPUT VECTORS
@STATE VECTORS
@TRANSITIONS
```

# Digital video evaluation module

# DTV9051

## 7-bit digital video evaluation module featuring the SAA9051 and TDA4680 integrated circuits

### THEORY OF OPERATION

The Digital Video Evaluation Board was designed to provide a compact, self-contained demonstration system for the Philips SAA9051 Digital Multistandard Color Television Decoder. The board accepts composite video (CVBS) signals or S-VHS (Y, C) signals and digitally decodes these input signals into luminance and color difference components. The digital outputs of the decoder are stored in a 6 Megabit frame memory and made available for output format conversion to analog red, green, and blue (RGB). An 87C751 microcontroller is required to send initialization information to various devices on the board.

In order to decode analog composite signals to component form, the TDA8708 8-bit A/D converter digitizes the input signal and sends the data to the SAA9051 Digital Multistandard Decoder. The digital decoder generates a 6.75MHz clock locked to the horizontal sync of the input CVBS signal. This 6.75MHz clock is sent to the SAA9057 clock generator for frequency multiplication to 13.5MHz and 27MHz. The 13.5MHz clock from the SAA9057 is sent back to the SAA9051 and TDA8708 and used as the system clock for digitizing and output timing of the SAA9051. The FIFO memories and the SAA9060 triple 8-bit D/A converter also use the 13.5MHz clock.

The digital data output from the SAA9051 is sent to the frame memory in a 12-bit data bus. The bus provides 8 bits form luminance and 4 bits for multiplexed chroma in a Y:U:V 4:1:1 ratio. Each field memory consists of 3 TMS4C1050 256K x 4 first-in-first-out (FIFO) memories. The field memories are always alternately read for output data but the writing, or input, to the memories can be stopped on an odd field boundary by pulling the still line to a logical LOW. A freeze frame of the input video signal is realized when a logical LOW is maintained on the still line.

After the data is read out of the frame memories, it is sent to the triple D/A converter, the SAA9060, for conversion to analog Y, R-Y, B-Y component signals. The gain of the SAA9060 is controlled via I<sup>2</sup>C serial control of a D/A connected to bias at Pin 8. The pull-up resistors on Pins 9, 10, and 11 are required to match the analog outputs of the SAA9060 to the input levels of the TDA4680 output RGB processor.

Finally, the TDA4680 RGB processor converts the color difference component signals back to RGB. The TDA4680 has the capability to control the black level, contrast, saturation, and individual gain of each RGB output. 75 ohm buffers are added to provide low impedance outputs for RGB and sync

signals. Three I<sup>2</sup>C-controlled D/As are connected to Pins 21, 23, and 25 of the TDA4680 to allow the black level of the RGB outputs to be individually adjusted.

The SAA9051 does more than just decode composite video input signals into their color difference components. The DMSD also provides two programmable timing signals for sync and clamping in the TDA8708 A/D. It also provides blanking, horizontal sync, and vertical sync for interface to memory and output circuits. The SAA9051 maintains a close relationship between the 13.5MHz clock and the input horizontal sync. The phase jitter of the master clock is kept in the 5 ns range. All output signals from the SAA9051 are synchronous to the 13.5MHz clock, and have proper set-up and hold times for easy interface to various types of memory.

If S-VHS capability is required, the TDA8709 A/D can be used to digitize the chroma portion of the input signal. The luminance signal must still be applied to the TDA8708 for digitizing and sync processing. The TDA8708 contains a three channel input multiplexer, AGC circuit, and black level clamp.

Another feature of this demonstration board is the absence of any chrominance or luminance delay lines. No mechanical adjustments are required. All parameters for color decoding and level setting can be made by microprocessor control. The SAA9051 can decode seven variations of PAL and NTSC formats and maintain vertical, horizontal, and color lock even in VCR shuttle or scan mode.

The 26-pin connector provides all digital and timing information on the output side of memory.

With minor modification, this evaluation board can be upgraded to accept the SAA7151 Digital Multistandard Decoder.

### DESIGN CONSIDERATIONS

A single 10 to 12-volt power supply was chosen to provide the simplest power supply connection. Most of the board uses 5 volt power. Therefore, the 5 volt power regulator dissipates about as much power as the rest of the board. The TDA4680 and TDA8444 are connected to the 8 volt power regulator. Analog +5V and digital +5V are isolated with 100μH inductors and bypassed at each active component. Special attention is paid to the data converter analog supply and clock generator circuit. The SAA9057 clock generator also has a bulk 220μF capacitor on analog supply to remove any low frequency ripple. A separate 5-volt regulator for this IC and the analog supply for the digital decoder

will keep clock jitter well below 10 nS relative to input sync.

Since the sample clock frequency of this system is 13.5MHz, it is important to take care in grounding in order to keep clock noise away from analog video inputs. A common ground plane is suggested for the data converters, SAA9051, and SAA9057. Other ground planes can be used for the output section and for any logic or memory requirement, but careful design should allow for one common ground connection point for all ground planes.

Another source of noise is clock feedthrough into the data converters. A resistor is normally placed in series with the clock line to slow down the fast rise and fall times. Stray capacitance of the wiring and input pins of the data converters will aid in reducing the high frequency energy coupled into analog circuits.

On the output side, noise can be easily coupled from digital data lines feeding the SAA9060 D/A converter to the analog output pins of this device. Careful trace layout is required in order to minimize clock or data interference.

### I<sup>2</sup>C COMMUNICATIONS

A Philips Semiconductors 87C751 microprocessor is supplied to send power-up information to the SAA9051, TDA8444, and TDA4680. Normally, roughly one second after power is supplied to the board, 20 data bytes are sent to various slave devices. This message will not support multi-master I<sup>2</sup>C protocol. Therefore, any connection to the I<sup>2</sup>C bus connection jack is forbidden unless it is in the high inactive state for clock and data.

If an external computer of CPU is used for I<sup>2</sup>C control, data transmission can safely begin three seconds after board power-up. By this time the 87C751 CPU has completed sending the power-up instruction sequence, and has entered a halt-inactive state.

Implementation of automatic broadcast standard detection would require ongoing I<sup>2</sup>C communication between the SAA9051 and the on-board CPU. This can be seen as activity on the clock and data lines of the I<sup>2</sup>C connector, making external control or testing of the board impossible. In this case, the 87C751 should be removed from the board to allow external I<sup>2</sup>C control of the digital decoder and analog functions.

Philips has made available I<sup>2</sup>C control software for hardware development and debug of I<sup>2</sup>C products. This software runs under MS-DOS, and uses a parallel printer port as an I/O connector. This software has user-friendly menus for various I<sup>2</sup>C devices as well as a universal message generator menu for control of any I<sup>2</sup>C device.

## Digital video evaluation module

DTV9051

### OUTPUT VIDEO BUFFERS

Most analog RGB monitor connections require 75 ohm source terminated, 1 volt peak-to-peak video signals. The RGB output connectors meet this requirement, but the analog output levels can be adjusted in the TDA4680 to about 6dB from the nominal 1 volt peak-to-peak standard. Sync is not supplied on the RGB lines.

Looking at the supplied schematic, you should note the 10 ohm resistors in the collector leads of the output transistors. These resistors are required to keep high frequency video signals off of the 5V power supply lines and reduce power dissipation in the output transistors. These output buffers are not power-efficient, but do provide a simple 75 ohm output stage and DC output level at ground during blanking time.

### GENERATION OF THE SANDCASTLE SIGNAL

A very simple resistor and diode circuit is used to generate the sandcastle signal required by the TDA 4680 for proper operation. Unfortunately, the SAA9060 has a 22 clock pipeline delay from data input to analog output. The same BLN signal from the SAA9051 is used for the SAA9060 and sandcastle, so there will be a slight loss of picture information on the right side of the screen in this implementation. Because monitors are typically overscanned, this shouldn't cause a visible effect. A delay of the BLN signal would be required to eliminate this loss of picture information.

### MEMORY INTERFACE AND FIELD ID GENERATION

This demonstration board contains 2 fields of memory organized as 256K × 12 bits each. Normal video signals are interlaced with even and odd fields. A D flip-flop can be clocked by vertical sync from the DMSD, and BLN can be used to determine and even or odd field by connecting it to the data input of the same flip-flop. This works well for standard signals.

The Field ID is used only as a reset for a divide-by-two flip-flop from vertical sync. In this way, if there is not a good field interlace, the field memories will still be written to on an alternate basis.

Only active picture information is stored in memory. The BLN signal is used to store 720 picture elements for each scan line. Each field memory has enough storage even for PAL video signals.

A digital data bus connector is provided on the output side of the memory for expansion to 8-bit 4:1:1 digital output format. The memories are rated for 30ns clock maximum.

Therefore, the memory could be read out at rates higher than 13.5MHz if modifications were made to the board.

### SYSTEM IMPROVEMENTS

There are several areas in the design of this board which can be improved if necessary.

The software for the microprocessor can be easily expanded to include automatic detection of broadcast standard by the SAA9051. Only about 10% of the 2KB ROM is currently used for board set-up.

This board is double-sided. If a ground plane were added, the system signal-to-noise ratio would be improved.

To improve stability of color and black level, an external circuit feeding RGB signals back into the TDA4680 dark current input is suggested. The external circuit required about six extra transistors and is not necessary for many applications. The TDA4680 application diagrams show this implementation.

### PC BOARD LAYOUT CONSIDERATIONS

The Philips DeskTop Video ICs are designed for lowest radiated and conducted noise performance. The high noise performance can only be achieved if great care is taken with the PC board layout. The layout should be optimized for lowest noise on the IC's analog and digital power and ground lines.

A good decoupling with minimized interconnection length between the decoupling capacitors and the corresponding IC pins is important for low inductive ringing.

### Analog and Digital Ground Planes

The DeskTop Video ICs with analog and digital circuits, such as A/D converter, color decoder, clock generator and D/A converter should have two separate ground planes. The lowest noise in the content of the digital data stream and a minimum uncertainty of clock jitter can be achieved on most of the PC boards by connecting both ground planes near the clock generator (SAA9057A, SAA7157, or SAA7197).

### Analog and Digital Power Supplies

The impedance of the power supply lines should be as low as possible. In order to provide EMI suppression in series to the analog supply pins of the ICs, a ferrite bead or, better, a ferrite EMI suppressor should be connected.

### Supply Decoupling

Decoupling capacitors can further reduce the noise on the power supply lines. For optimum performance, a 100nF multilayer ceramic capacitor should be placed as close as possible to every supply pin of the ICs and should be connected to the corresponding digital or analog ground plane. This is needed especially for the analog supply Pins 4 and 5 at the clock generator. In addition to the multilayer ceramic capacitors, a 5–10μF electrolytic capacitor should be placed near each IC.

### Analog Signal Lines

The analog part of the board design should be isolated as much as possible from the digital signal and clock lines.

Optimum performance is achieved by overlaying the analog components with the analog ground plane.

The video signal lines at the A/D converter TDA8708 and TDA8709 from Pin 19 to Pin 20 should be as short as possible to minimize noise pickup.

## Digital video evaluation module

DTV9051

**I<sup>2</sup>C VALUES**

The following values are loaded into the I<sup>2</sup>C-addressable components at power-up. This corresponds to video input #1, NTSC, NTSC matrix, 1 volt peak-to-peak output.

SAA9051	TDA8444	TDA4680
Slave Address 8AH	Slave Address 40H	Slave Address 88H
64H Reg 00	26H Reg 00	2AH Reg 00
35H	26H	13H
0AH	1EH	33H
f8H	00H	22H
CAH	00H	34H
FEH	23H	34H
29H	3FH	34H
00H	3FH	20H
77H		20H
E0H		20H
40H		3FH Reg 0AH
00H		89H Reg 0CH
		10H Reg 0DH

**NOTE:**  
TDA4680 register 0BH is omitted. The TDA4670 responds to this subaddress only.

**CONCLUSION**

This digital multistandard decoder board provides a means of evaluating the performance of the Philips digital television system, and of quickly prototyping your application. The digital video system delivers a robust, flexible, and cost-effective solution for digitizing video images.



## Digital video evaluation module

DTV9051

## PHILIPS DMSD2 DEMO BOARD PARTS LIST (Revised May 10, 1991)

ITEM	QUANTITY	REFERENCE	PART
1	8	J-Y/C CHROMA1, J-BLU 1, J-GREEN1, J-IN1, J-RED1, J-SYNC1, J-IN2, J-IN3	BNC
2	8	R1, R2, R3, R4, R5, R6, R7, R8	75
3	1	S1	SW SPDT
4	2	R46, R47	6.8K
5	1	C5	0.22
6	7	R11, R10, R12, R21, R48, R49, R50	10K
7	1	JP2	10 volt in
8	1	J-IIC1	4 PIN
9	1	P1	DB26
10	1	JP1	BLANK JUMP
11	5	C1, C2, C3, C4, C39	3.3/16V
12	1	VR1	LM7805
13	1	VR2	LM7808
14	35	C69, C6, C9, C14, C17, C22, C23, C24, C25, C26, C27, C29, C33, C34, C35, C40, C41, C42, C43, C44, C45, C58, C59, C60, C61, C62, C63, C64, C65, C66, C74, C75, C77, C81, C86	0.1
15	6	C70, C49, C50, C68, C71, C73	22/20V
16	1	C72	220/10V
17	14	C76, C28, C30, C31, C32, C46, C47, C52, C53, C54, C55, C78, C79, C80	22/16V
18	3	L5, L4, L7	100 $\mu$ H
19	1	L6	100 $\mu$ H
20	1	U1	TDA8709
21	1	U2	TDA8708
22	1	U3	SAA9051
23	1	C7	0.33
24	2	R13, R36	330
25	4	R14, R16, R18, R19	750
26	2	R15, R60	680K
27	1	Y1	24.576
28	2	L2, L3	22 $\mu$ H
29	2	C10, C12	30pF
30	2	C11, C13	30pF
31	1	R17	15
32	1	U4	SAA9057
33	2	R20, R39	470
34	2	JP3, JPDMSD ADD	HEADER 3
35	1	C8	1nF
36	1	L1	10 $\mu$ F
37	2	C15, C16	1/16V

## Digital video evaluation module

DTV9051

**PHILIPS DMSD2 DEMO BOARD PARTS LIST** (Revised May 10, 1991)

ITEM	QUANTITY	REFERENCE	PART
38	4	R26, R43, R44, R45	68
39	4	R27, R51, R52, R53	10
40	9	R28, R29, R30, R31, R32, R33, R54, R55, R56	4.7K
41	5	Q1, Q2, Q3, Q4, Q5	PN2222
42	2	C20, C21	10nF
43	5	D2, D3, D4, D5, D6	1N4148
44	3	U7, U6, U9	74HC74
45	2	U8, U5	74AHCT27
46	1	C19	33pF
47	1	R34	8.2K
48	1	R35	2.4K
49	6	U10, U11, U12, U13, U14, U15	TMS4C1050
50	1	JP5	JUMPER
51	1	R59	56K
52	1	Y20	3.5 - 12 MHz
53	1	C83	3.3nF
54	2	C85, C84	20pF
55	1	C82	15/16V
56	1	U16	S87C751-XXXX
57	1	U17	PCF8582AP
58	1	R37	560
59	1	R38	820
60	1	R40	680
61	2	R41, R42	100
62	1	C36	100pF
63	2	C37, C38	330pF
64	1	JP4	WIRE
65	1	U21	SAA9060
66	1	U22	TDA4680
67	1	U20	TDA8444
68	1	R58	82K
69	2	R57, R60	20K
70	1	R9	12K

# Digital video evaluation module

DTV9051

## BLOCK DIAGRAM

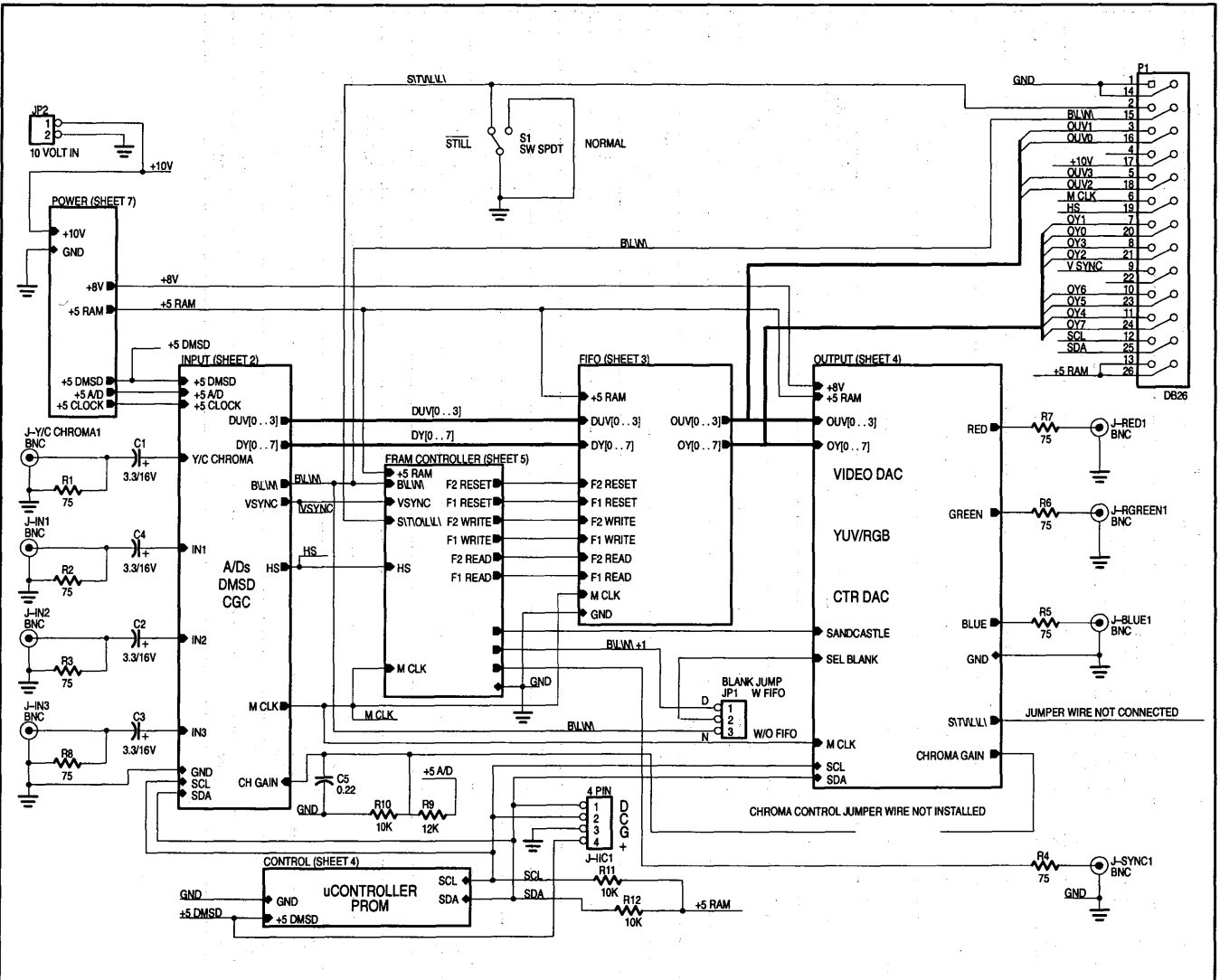





# Digital video evaluation module

DTV9051

## PHILIPS DMSD2 DEMO BOARD - FIFO

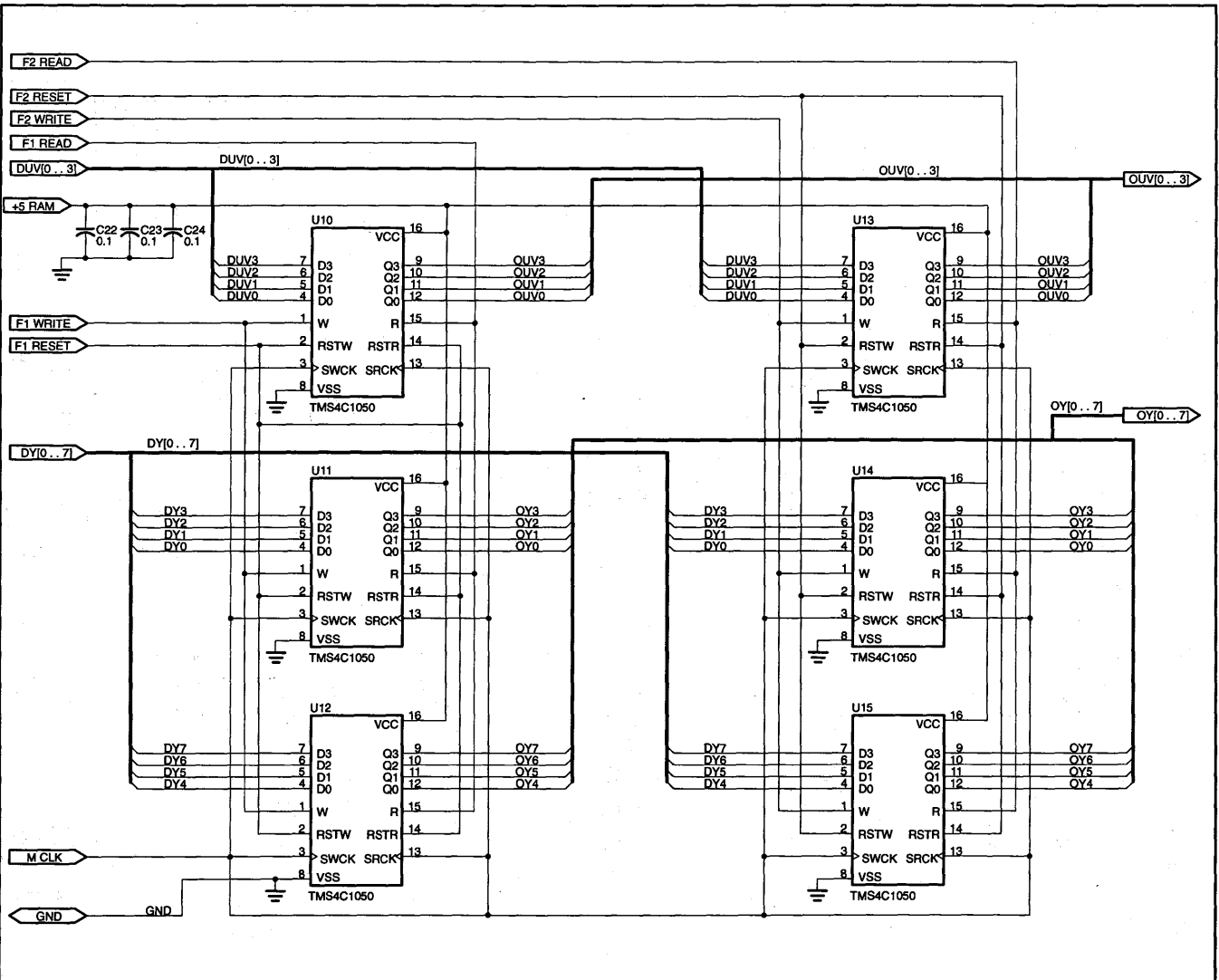

# Digital video evaluation module

DTV9051

## PHILIPS DM5D2 DEMO BOARD - OUTPUT

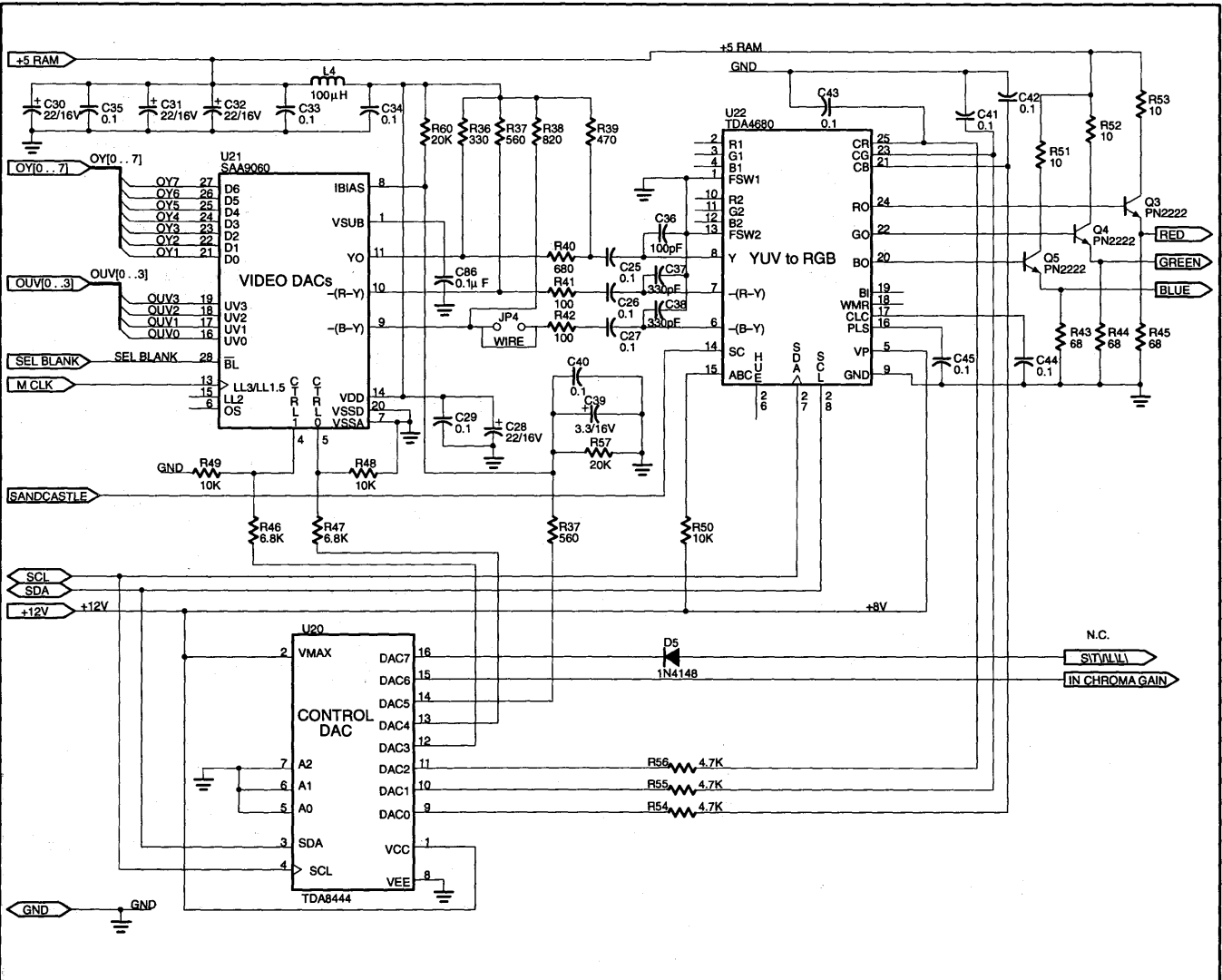

# Digital video evaluation module

DTV9051

## PHILIPS DMSD2 DEMO BOARD - FRAM CONTROLLER

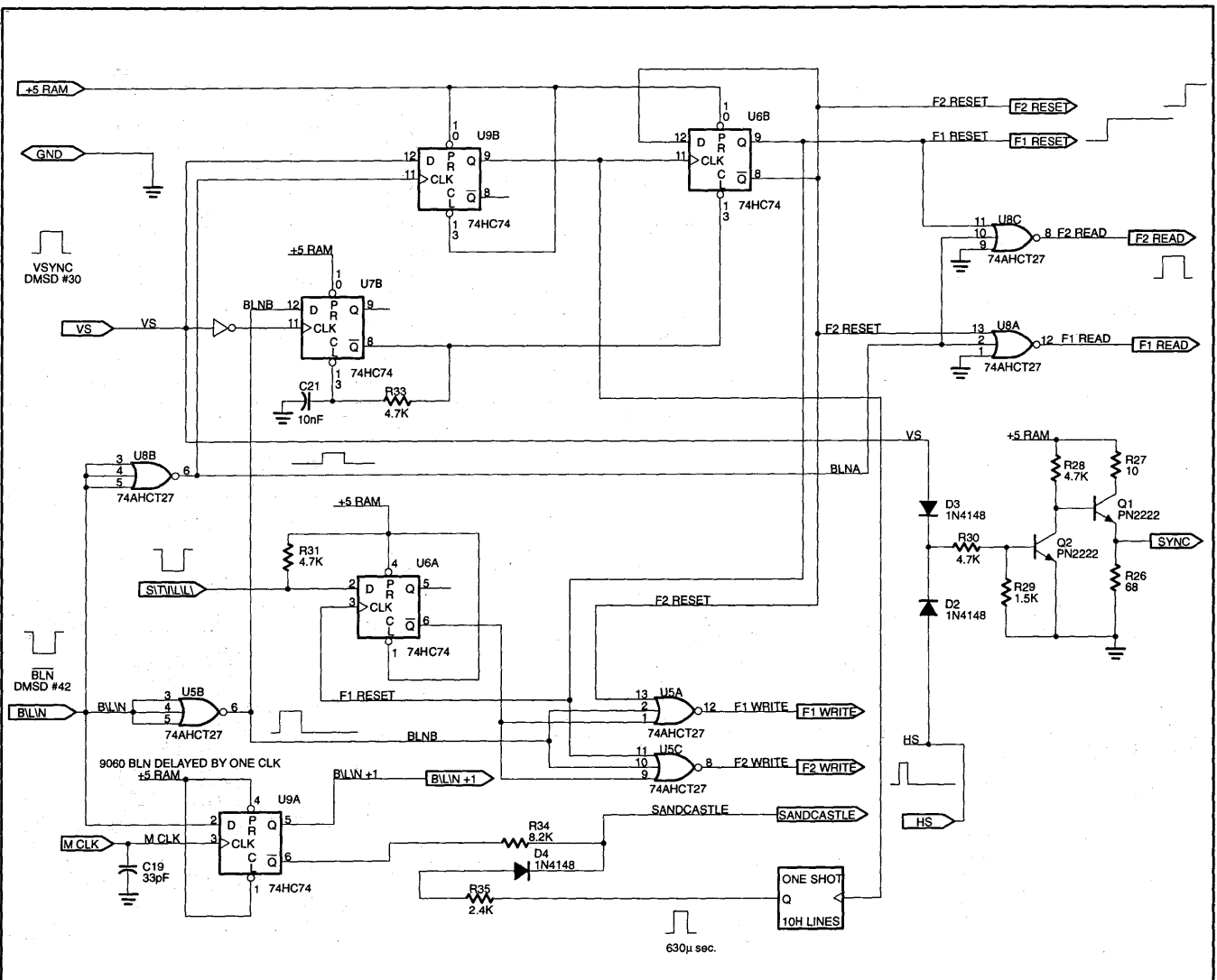

# Digital video evaluation module

DTV9051

## PHILIPS DMSD2 DEMO BOARD - CONTROL

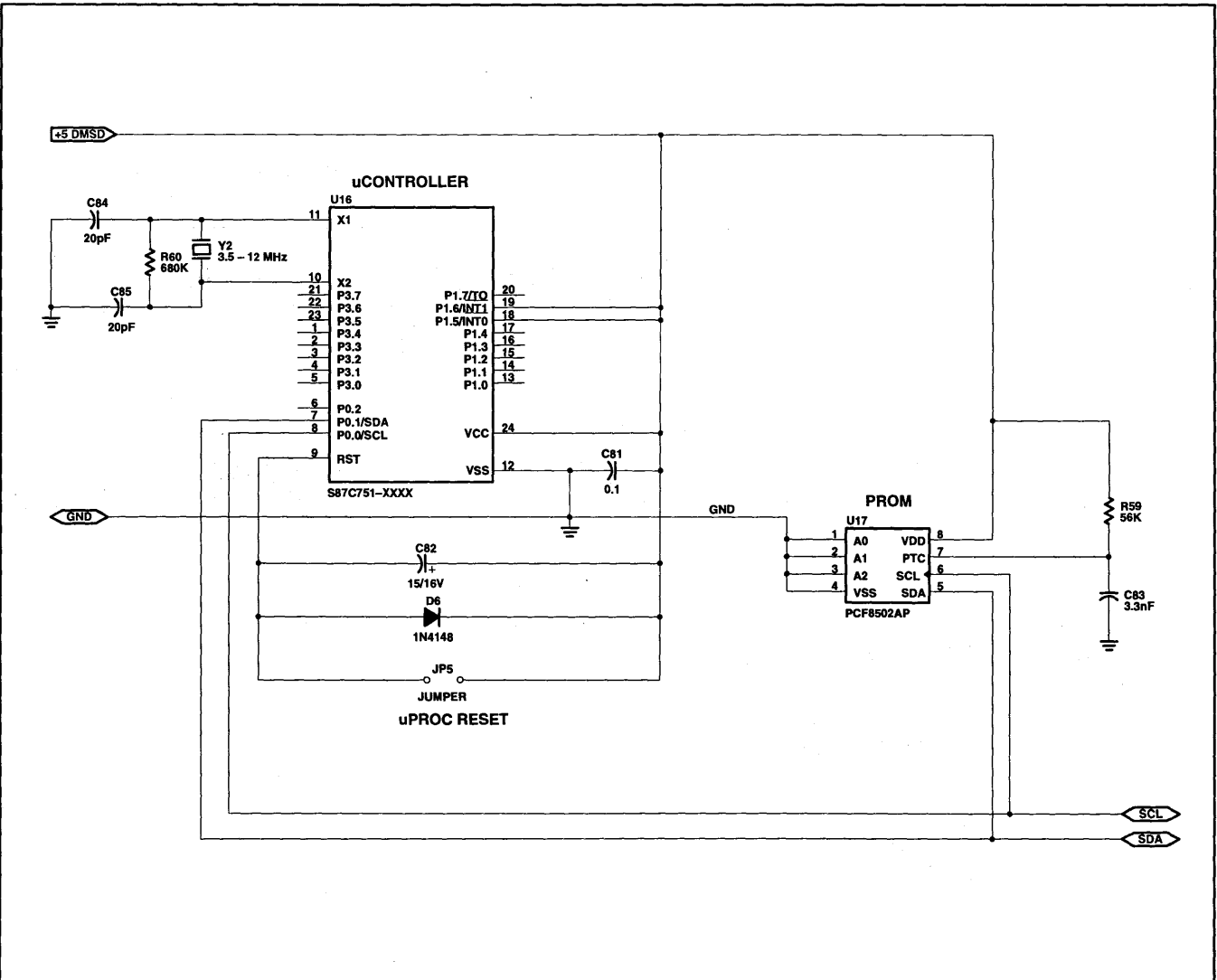

# Digital video evaluation module

DTV9051

## PHILIPS DMSD2 DEMO BOARD - POWER

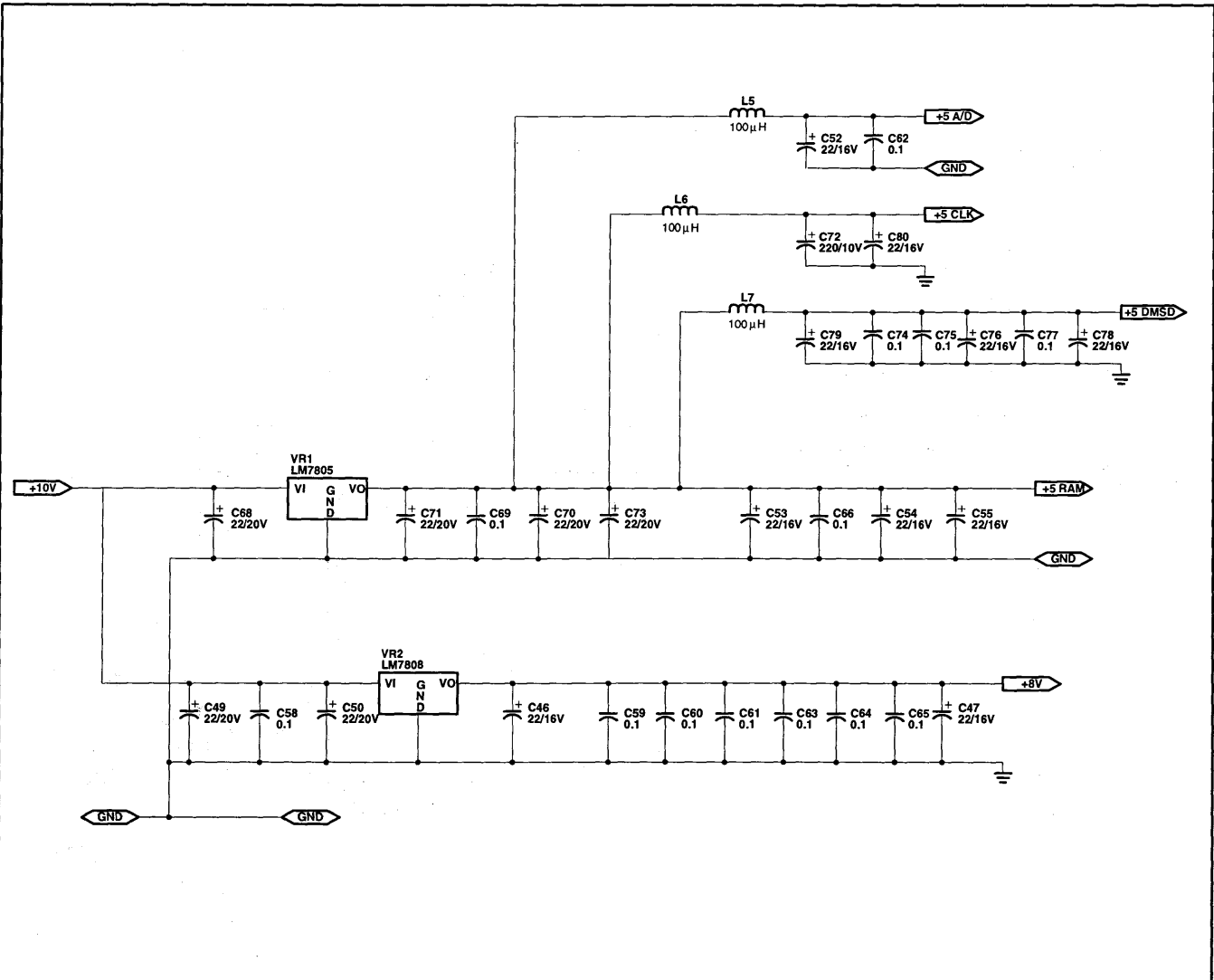

# Digital video evaluation module

# DTV9051

## PHILIPS SAA9051 V5.0 AND SAA7191 V1 BLANK AND SYNC TIMING

NOTE: VNL ON, VCR Mode

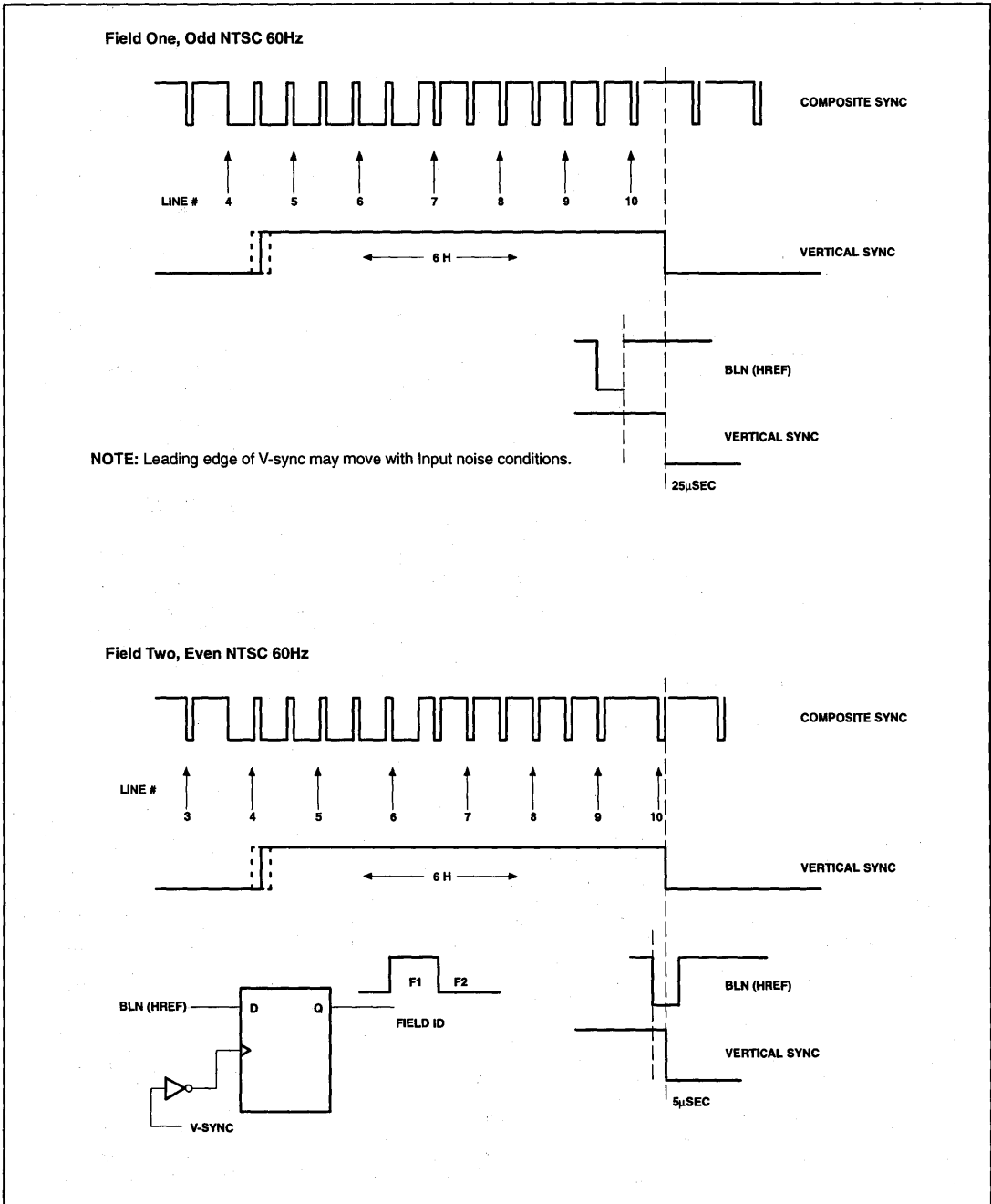

# DTV7199 Digital Television Demonstration System

Author: Herb Knies

## SECTION 1: OVERVIEW

The DTV7199 evaluation board provides a comprehensive means of demonstrating and evaluating the latest digital video signal processing devices from Philips Semiconductors. Color encoding and decoding is performed using a line-locked-clock system. The following ICs are featured:

TDA8708	Video A/D converter, 30MHz, 8-bit, for CVBS and Y, with analog pre-processing, clamp and gain control
TDA8709	Video A/D converter, 30MHz, 8-bit, for C of S-Video, with analog pre-processing, clamp and gain control
SAA7151B	Digital Multi Standard Decoder (DMSD), for CCIR-601 pixel raster (industrial applications)
SAA7157	Clock Generator Circuit (CGC) for SAA7191B
SAA7191	Digital Multi Standard Decoder (DMSD), for square pixel raster (graphics environment)
SAA7197	Clock Generator Circuit (CGC) for SAA7191
SAA7192A	Digital Color Space Converter (DCSC), interpolation filter, YUV to RGB matrix
SAA7169	Triple DAC, 30MHz, 9-bit in each channel
SAA7199B	Digital Encoder (DENC), GENLOCK capable, from digital YUV or RGB into analog CVBS or S-Video
S87C054	Microcontroller, 8051-based, dedicated for video control applications, with OSD, on-chip EPROM.

Analog video input is accepted in CVBS or S-Video form, in NTSC, PAL, or SECAM color standards. The video signals are digitized and sent to the digital decoder (DMSD) SAA7151B or SAA7191B for synchronization processing, line-locked-clock generation, and color decoding. The output bus of the DMSD contains digital YUV baseband information. The data is sent to a two-field frame store for buffering and time base conversion. After the frame buffer, the YUV data is converted to 24-bit RGB data in the SAA7192A color space converter. The 24-bit RGB data is fed to the SAA7169 Triple DAC for analog RGB output conversion and also to the SAA7199B digital encoder (DENC). The encoder can be programmed in various modes, such as GENLOCK so that time base correction of input signals is

possible. The encoder can operate in NTSC or PAL television standards.

Various board configurations are possible by changing jumper settings and by reprogramming several of the signal processing devices. In addition, two 60-pin headers are provided to allow external connection of digital YUV data before and after the frame buffer. The MTV onboard microprocessor sends configuration data to various devices via an I<sup>2</sup>C serial two-wire bus. A connector for the serial data is also provided to allow external computer control to the board via a DOS software package supplied with each board.

## SECTION 2: INPUT VIDEO DATA CONVERSION

Input video sources can be NTSC, PAL, or SECAM world standards in Y/C or composite formats by four BNC connectors. Refer to "Input" section schematic. An S-Video or Y/C connector is provided at JVSID2 for these higher performance Y/C input signals. The Philips TDA8708 8-bit 30MHz A/D converter at location U2 is used for composite or Y signal processing. It has a three-channel multiplexer for input source selection, video clamp for DC restoration, and automatic gain control in front of the high performance 8-bit A/D converter. Input source selection is controlled via two switch signals from the SAA7191 and connected to the TDA8708 at Pins 14 and 15. The switch signals are programmed in the DMSDs via the I<sup>2</sup>C bus.

If the higher performance Y/C input format is desired, a second data converter is required for digitizing the chrominance, or "C", half of the input signal. The TDA8709 at location U1 provides this function. Low pass filters for removing high frequency components in the analog input signals are provided between Pins 19 and 20 of both A/D converters before digitizing. Please note that the AC reference for the converters is the analog power supply. The power supplies for these devices are well decoupled since the performance of the entire system is determined at the input data converters. The digitizing clock is provided by the SAA7197 clock generator at location U3 with a rate of two times the final pixel rate for decoded signal at the output of the DMSD. The clock rate of the converters is line-loaded and can range from 24- to 30MHz depending on input television standards and the type of digital decoder used. The clock input on Pin 5 of both A/D converters is fed with a series resistor, which slows the clock slopes down in order to minimize the effect of high rise times from the clock line entering

analog areas around the converter. Clamping and sync pulses coming from the decoder are fed to the A/D converters on Pins 27 and 26 to inform internal digital level detectors when to activate and make automatic adjustments of gain and black level on each scan line.

It is recommended that the input signal area and the data converters share a common ground plane for analog and digital grounds at the converters. However, it is possible to have separate ground planes and have the common point under the data converters on Pins 23 and 8. High amplitude noise between Pins 23 and 8 should be avoided. Otherwise it may cause ground loop conditions within the converters. The entire video signal is digitized in order to recover the sync and color burst information. The converters deliver 8-bit digital data in a two's complement format to the decoder input. The format selection is made by grounding Pin 9 on both converters. For other applications the A/D converters can be operated in binary format.

## SECTION 3: DIGITAL COLOR DECODING

After converting analog video inputs to digital data it is the function of the Digital Multi Standard Decoder (DMSD) to provide clock information, sync, blanking and, of course, luminance and decoded color difference video data known as YUV or Y, RY, BY. Refer to the "Input" section schematic.

The output signals are all synchronized to the input video timing in frequency and phase via a clock control loop feeding from U4 DMSD on Pin 36 called Line Frequency Control Output (LFCO) to U3 SAA7197 clock generator. LFCO is internally generated via the crystal reference on Pins 33 and 34 of the DMSD and made to phase lock to incoming video sync. The frequency of LFCO is one half of the pixel clock frequency at the output of the DMSD, so the SAA7197 must multiply this synthesized frequency by 2 and 4 for the system line-locked clock. In order to close the PLL loop, the clock generators' clock outputs are fed back to the DMSD clock inputs and the A/D converters' clock inputs. The system works as a highly stable digital PLL because the DMSD calculates the clock frequency of LFCO on a line-by-line basis and in conjunction with the crystal reference maintains a constant number of clock samples for each input video scan line regardless of input signal conditions.

The DMSD also decodes the color information from video signals. The UV



# DTV7199 Digital Television Demonstration System

output bus contains the color information in one of several programmable industry standard formats such as CCIR 601. In CCIR 601 the output data bus is 8 bits Y of luminance and 8 bits UV time multiplexed. This is 16 bits per pixel or clock cycle. A 4:1:1 mode is also available via I<sup>2</sup>C programming if memory cost is too high for 4:2:2 CCIR 601 mode. RAMs U8 and U9 could be removed for 4:1:1 operational mode. The DTV7199 demo board is capable for applications of the square pixel DMSD SAA7191B as well as of the CCIR-DMSD SAA7151B. Only the DMSD IC and the related reference crystal must be exchanged (see Table 2). The board layout is prepared to support both systems. Also, the MTV controller contains software to set up both ICs.

## SECTION 4: MEMORY INTERFACE AND STORAGE

The 16-bit data bus from the DMSD is being clocked at rates from 12-15MHz. High speed serial RAMs were chosen to store the data without the need for memory addressing and counting chains. Refer to FIFO and MEMCON schematic. Each RAM is really a FIFO with 256k by 4 bits memory. Input and output clocks can run independently with some limiting restrictions. Four RAMs, U9, U10, U11, U12, make up a bank for field one. Four RAMs, U8, U7, U6, U5, make up the bank for field two. If memory cost is too high for 4:2:2 CCIR 601 mode, RAMs U8 and U9 could be removed for 4:1:1 operational mode. Video data from the DMSD is stored alternately in each bank. Only data during active portion of each scan line is written to the memory. Less than 75% of the RAM is used for each incoming field, even in PAL or SECAM modes.

The simple memory controller comprised of U15, U17, U19, U51, U20, U21 and U54 uses vertical sync to reset the memory pointers and horizontal blanking to stop and start reading and writing the memory. The top portion of the schematic is for writing into memory. The bottom portion is for reading from memory. Devices U15 and U54 provide timing delays to guarantee that complete fields will be stored in memory. U51B will inhibit writing to memory on frame boundaries and provide a freeze frame picture for quality analysis and special effects. Both fields will be displayed so there may be inter-field motion displayed on the monitor. The "still picture" switch activates the freeze frame with a low on U51B Pin 12. Switch S1 must be in the down position for active video. The up position is for still frame (both fields).

The DMSD generates an H<sub>REF</sub> signal for enabling writing to memory. A comparable signal must be generated for reading from memory. The SAA7199B encoder does not deliver such a Horizontal Blanking, but needs to receive it. H<sub>REF0</sub>, or Horizontal Blanking, is generated via counters for output video timing only by using HSYNC from DENC to trigger counters. Refer to H<sub>REFGEN</sub> schematic.

The H<sub>REF</sub> generator times the correct horizontal blanking interval and generates a delayed HSYNC signal for display monitor from the HSYNC from the SAA7199B encoder. U26 Pin 2 receives HSYNC from the encoder and generates a single clock reset pulse via U27 Pin 3 to reset U28 and U29 counters. The output timing diagram and clock cycles are shown. It is important only that the total number of clock cycles of H<sub>REF0</sub> at U53 Pin 6 be set properly regarding display and SAA7199B timing scheme. Table 1 shows how to select the memory read blanking timing interval depending on how the board is programmed, which standard is applied and which type of decoder is installed. If there is an error between memory write format (number of pixels per line) and memory read format, there will be a horizontal error line-by-line down the screen because the line lengths are different.

HSYNC0 is generated at U27 Pin 6 with a delay because of the pipeline delay through the SAA7192A color space converter. The RGB data must be in time with the RGB sync at the SAA7169 DAC outputs. Transistor Q2 provides composite sync for RGB monitors.

Data for the SAA7199B must be read from memory early to compensate the delay through the SAA7192A color space converter. The SAA7199B encoder has a programmable HSYNC for this very reason. It is not known what delay future memory or memory controllers will produce so the SAA7199B is prepared to adjust for new devices.

## SECTION 5: COLOR SPACE CONVERSION AND DAC

Data from memory read operations is passed through jumper JP14 to the Digital Color Space Converter SAA7192A. Refer to SAA7192 schematic. Normally 24 jumpers are installed on the board to pass data from the memory through the connector. However, a daughter board can be added using JP3 and JP14 to multiplex YUV or RGB data at JP14. The data coming from memory must be disabled via the expansion board. Make special note of U16 Pin 5. H<sub>REF0</sub> is delayed

by one additional clock to compensate for the memory read delay of one clock. If this delay is not compensated for from the memory, the color space converter will not demultiplex the UV data bus correctly. U47, U48, U49 switch data on to the RGB output bus of the SAA7192A when MTV 87C054 says there is a character to display. The VCTRL signal from MTV controls which talks into the RGB data bus, either the SAA7192A or the MTV. Pin 61 of the SAA7192A tri-states its output RGB bus.

The SAA7169 DAC is wired in a standard configuration, with the low order 2 bits of all three 10-bit wide input ports grounded for 8-bit operation. RP1 and RP2 provide low order bit pull-up when the RGB data bus is switched to MTV-source in order to meet the CCIR 601 requirement of 16 for black levels. JP13 chooses two clock phases for U50. MEMRD is preferred.

## SECTION 6: DIGITAL ENCODER AND GENLOCK

The SAA7191 decoder provides the memory write clocks and timing, and the SAA7199B digital encoder provides the memory read clocks and timing. These input and output clocks can be synchronous or asynchronous. The digital encoder will synchronize to any video reference input signal via U23 TDA8708 in the same manner as the SAA7191 DMSD if programmed to do so (GENLOCK mode). Refer to previous discussions on Digital Decoding. It can also run in a stable mode, by use of its crystal reference and U24 SAA7197 clock generator.

A small change in the output level of the SAA7199B DACs can be made by changing the bias on Pin 63. Linearity may be affected with large changes in bias. Key input at Pin 73 has been deactivated by pull-down resistor R45. The clock generator power supply has been well filtered at Pin 5 to guarantee minimum effects from input video timing crosstalk. Crystal selection for the SAA7199B should be made as shown in Table 2. See application note "SAA7199B Operation Modes".

## SECTION 7: POWER SUPPLY GROUNDING AND LAYOUT

Clean analog power supplies are essential if the full performance of an 8-bit system is to be realized. The analog supplies on the A/D converters and the clock generator are the most sensitive. The performance of the A/D converter determines the signal-to-noise ratio of the complete system. The performance of

## DTV7199 Digital Television Demonstration System

---

the clock generator determines system clock jitter and, to some extent, the quality of the chroma demodulation.

Noise on Pins 21 and 22 of the TDA8708 A/D converter will degrade the signal-to-noise ratio of analog input signals. Please note that the low pass filter at Pins 19 and 20 has an AC reference to the analog supply on Pin 22. Therefore, noise on Pin 22 would directly be coupled to input signals being digitized.

The SAA7197 must have a clean analog supply at Pin 5 which must be directly connected to Pin 37 on the SAA7191B or SAA7151B decoders because of the close coupling of the LFCO signal between the clock generator and the decoders. Bypassing capacitors at pins of both devices is a must. Of course, all digital power inputs must be bypassed on all devices.

The DTV7199 evaluation board makes use of one other power supply isolation technique. The input and output supplies are regulated separately. This isolation guarantees minimum crosstalk between input decoding and output encoding. Small ferrite core

inductors further reduce analog and digital supply crosstalk.

In many computer applications it is not possible to regulate the digital supplies because of current limits placed on higher supply voltages. In this case, only the lower current analog supplies should be regulated. Total analog supply current is under 100mA for input circuits and also under 100mA for output circuits. Because of delay differences in power supply sequencing during power up, it is suggested that 5V regulated analog supplies have parallel opposite biased diodes connected to the digital supply. This will keep both supplies in sync during power up. This is needed to perform a determined power-on reset procedure at SAA7157 and SAA7197. 1N4148 diodes will supply enough current for a short period of time and allow regulation isolation of about 600mV.

A single ground plane has been shown to be effective under input components and ICs such as the TDA8708, SAA7197 and SAA7191B. After the decoder, a digital ground plane could be used if there are a large number of digital devices and fast

memory. The input ground plane could be considered analog ground. The evaluation board uses a single ground plane for the entire board. A single ground plane appears to work well for most applications.

Clock and data line routing should be kept away from analog components and analog signals. The most critical signal is LFCO between the digital decoder and the clock generator. It has an analog characteristic and may pick up unwanted digital noise. The length of the LFCO trace between these two devices must be kept to a minimum.

### SECTION 8: FACTORY JUMPER CONFIGURATION

The factory jumper configuration is required for normal operation of the DTV7199 demo board when the 87C054 microcontroller has been installed. Software version 1.x will only configure the board for NTSC mode using the SAA7191 decoder with video input connected to JIN2. Any one of the push buttons can be used to switch the "Philips Digital Video" message on the screen on and off.

## DTV7199 Digital Television Demonstration System

**Table 1: H<sub>REF</sub> Length Jumper Table**

12.272727	60Hz	140	SQUARE PIXELS	SAA7191
14.75	50Hz	176	SQUARE PIXELS	SAA7191
13.50	60Hz	138	CCIR 601	SAA7151B (SAA9051)
13.50	50Hz	144	CCIR 601	SAA7151B (SAA9051)

**Table 2: Crystal Selection**

SYSTEM	ACTIVE PIXELS	CRYSTAL	DECODER
SQUARE PIXELS	640 or 768	26.800MHz	SAA7191 decoder
CCIR 601	720	24.576MHz	SAA7151 decoder

**Table 3: Factory Jumper Settings**

JP3	Install all jumpers except bottom six.
JP14	Install all jumpers except bottom six.
JP2	Install jumper to left for SAA7151 (right for SAA7191).
JP20	Installed
JP5	Install jumper to the left.
JP7	Open
JP8	Open
JP6	Open. This is the microprocessor reset.
JP13	Install jumper to the right.
JP19	Open. Install jumpers only if RTC function is required.
JI <sup>2</sup> C	This connector is for I <sup>2</sup> C communications.
JP15	Install jumpers depending on which decoder is used. (See previous section on H <sub>REF</sub> LENGTH JUMPER TABLE.)

## DTV7199 Digital Television Demonstration System

Table 4. JP3 Functions

PINS	JP3 FUNCTIONS
1,2	DY7
3,4	DY6
5,6	DY5
7,8	DY4
9,10	DY3
11,12	DY2
13,14	DY1
15,16	DY0
17,18	DUV7
19,20	DUV6
21,22	DUV5
23,24	DUV4
25,26	DUV3
27,28	DUV2
29,30	DUV1
31,32	DUV0
33,34	LLCI
35,36	VSI
37,38	H <sub>REFI</sub>
39,40	CREFI
41,42	LL3I
43,44	HSI
45,46	SDA
47,48	SCL
49,50	FEIN
51,52	RESI
53,54	
55,56	
57,58	GROUND
59,60	GROUND

Table 5. JP14 Functions

PINS	JP14 FUNCTIONS
1,2	OY7
3,4	OY6
5,6	OY5
7,8	OY4
9,10	OY3
11,12	OY2
13,14	OY1
15,16	OY0
17,18	OY7
19,20	OY6
21,22	OY5
23,24	OY4
25,26	OY3
27,28	OY2
29,30	OY1
31,32	OY0
33,34	OY7
35,36	OY6
37,38	OY5
39,40	OY4
41,42	OY3
43,44	OY2
45,46	OY1
47,48	OY0
49,50	H <sub>REF0</sub> , KEY
51,52	MEMREAD, RES0
53,54	LLCO, VSYNC0
55,56	LL30, OPT2
57,58	CREFO, OPT1
59,60	GROUND

# DTV7199 Digital Television Demonstration System

## SECTION 9: DEFAULT REGISTER CONFIGURATION VALUES

For composite video input at JIN2; Decoding of NTSC into YUV 4:2:2.

NTSC – SQUARE PIXEL		
REGISTER (HEX)	SAA7191	SAA7199B
00	50H	DCH
01	7FH	00H
02	53H	00H
03	43H	00H
04	19H	F0H
05	00H	2DH
06	19H	52H
07	00H	0AH
08	7FH	30H
09	7FH	00H
0A	7FH	00H
0B	7FH	00H
0C	40H	56H
0D	80H	00H
0E	79H	0CH
0F	78H	
10	00H	
11	18H	
12	00H*	
13	00H*	
14	36H	
15	0BH	
16	FEH	
17	D2H	
18	00H	

NTSC – CCIR MODE		
REGISTER (HEX)	SAA7151B	SAA7199B
00	66H	DCH
01	3AH	00H
02	07H	00H
03	F7H	00H
04	CBH	F0H
05	00H	2BH
06	35H	52H
07	00H	11H
08	B0H	30H
09	30H	00H
0A	7FH	00H
0B	7FH	00H
0C	24H	0FH
0D	4CH	00H
0E	30H	0DH
0F	58H	
10	60H	
11	21H	
12	C0H	

NOTE: SAA7192A is always programmed in register 0 with 2A hex.

\* Reserved; Program as 00H only.

# DTV7199 Digital Television Demonstration System

## SECTION 10: MENU CONTROLLED SOFTWARE (DVS)

The Desktop Video Software (DVS) package supports programming of the digital video ICs on the demo board DTV7199. It guides the user with a menu-controlled graphic interface, showing how to program individual functions and bits accessible by the I<sup>2</sup>C bus. Detailed device I<sup>2</sup>C register data can be obtained by using the "special options" function. The software runs on a PC or compatible and talks to the I<sup>2</sup>C bus via an interface board at the parallel printer port. See application note "I<sup>2</sup>C Parallel Printer Port Adaptor". The DVS also allows a software-only demonstration mode; neither I<sup>2</sup>C bus interface nor device samples are required to be connected to operate this demo-mode.

This section gives a short guideline on how to get started using the Desktop Video control software for demonstration and evaluation purposes. The menu-controlled software offers a lot more features than the fundamental functions described here.

### How to Use the Software-only Demonstration Mode

#### Required Equipment

The following equipment is required to operate the DVS software in demonstration mode:

- IBM-PC/AT compatible personal computer, with at least 384 Kbytes of system memory available
- MS-DOS or PC-DOS operating system
- preferably a color graphics adaptor and associated monitor
- floppy disk containing the DVS software and setup files

#### Procedure

Follow the instructions step by step to install the software and get it started:

Switch the personal computer and its monitor on. Wait for completion of self test and booting of the operation system.

Insert the floppy disk containing the Desktop Video Software into a disk drive. Change the current home drive to this drive.

You may copy the content of the DVS floppy into a dedicated directory on the hard disk. This will improve the speed for loading the program and the related utility and setup files.

Type "DVS <enter>" to start DVS. The control software will display "Philips Semiconductors" on the PC screen and perform an automatic search for installed

desktop video devices and their respective I<sup>2</sup>C addresses. Because in demonstration mode there are no such devices connected, the search will result in "not in use" noted on the screen for all devices supported by the software.

Set the devices of interest "active" by using the "+" key on the numeric keypad and the cursor up/down to move to the concerned devices.

Hit "<enter>" to finish the device activation and to proceed with the page assignment procedure. A default device-to-page assignment is offered. If you like, use the function keys to redefine the page assignment.

Hit "<center>" to confirm the device to page assignment and to proceed.

I<sup>2</sup>C bus check will report "not ready".

Enable demonstration mode by choosing "A" to neglect real I<sup>2</sup>C bus operation.

Load any of the predefined settings: Press "F" to select the file selection menu, press "L" and enter a filename. "D" gives a directory of available settings.

Now you have access to all the programming parameters of the selected 'active' devices. Every device is assigned to a page number and can be selected by typing the appropriate function key. Subject to the amount of programmability for a certain IC, the page may have sub-pages called sheets, which are accessible with page up/page down.

Move the cursor up/down to select a parameter. Use "+/-" keys of the numeric keypad to change the selected parameter.

### The DTV7199 Demonstration Board under Control of DVS

#### Required Equipment

In order to operate the Demo Board DTV7199 under DVS control the following items are required in addition to that which is mentioned for the software-only demonstration mode:

- Demo Board DTV7199
- Power supply 8V DC, 1A
- I<sup>2</sup>C bus adapter board, to be connected to the PC's parallel printer board and associated I<sup>2</sup>C cable
- one or two video signal sources, e.g., video test pattern generator, or a video camera, video tape recorder, etc.
- RGB monitor, capable of displaying analog RGB inputs at television frequencies of

15-16kHz horizontal and 50/60Hz vertical scan frequencies, and/or

- TV-monitor, with built-in color decoder, with 'external' CVBS or S-Video input
- cables to connect the video signal source to the board (BNC or S-Video), cables to connect the board's RGB output (BNC) to the monitor, cable to connect the encoded CVBS from the board (BNC or S-Video) to the TV monitor.

#### Procedure

Follow the instructions step by step to power up the system and run the software:

Connect the DTV7199 demo board with a signal source at the input BNC connector JIN2. Switch the signal source on.

Connect the RGB outputs and associated sync BNC connectors with a RGB monitor, or

Connect the encoder output CVBS-out or S-Video out with a TV monitor.

Power up the demo board with the I<sup>2</sup>C cable *not* connected to the board. The on-board control software embedded in the MTV loads the default parameters. This requires a few seconds and then the I<sup>2</sup>C bus is idle.

The monitor shows a picture according to the default settings.

Plug the I<sup>2</sup>C bus adapter board into the parallel printer connector (Centronics Interface) of the personal computer. Connect the I<sup>2</sup>C cable (gray, 4 wires) to this I<sup>2</sup>C bus adapter board.

Switch the personal computer and its monitor on. Wait for completion of self test and booting of the operation system.

Insert the floppy disk containing the Desktop Video Software into a disk drive. Change the current home drive to this drive.

You may copy the content of the DVS floppy into a dedicated directory on the hard disk. This will improve the speed for loading the program and the related utility and setup files.

Type "DVS <enter>" to start DVS. The control software will display "Philips Semiconductors" on the PC screen and perform an automatic search for installed desktop video devices and their respective addresses. The found devices are listed with their I<sup>2</sup>C addresses and declared as "active". If necessary, that can be changed using cursor keys and "+/-" keys.

Hit "<enter>" to confirm the device search program results as displayed and to

## DTV7199 Digital Television Demonstration System

proceed to the page assignment procedure. A default device-to-page assignment is offered. If you like, use the function keys to redefine the page assignment.

Hit "<enter>" to confirm the device to page assignment and to proceed.

In normal DVS operation mode the initialization is performed by selecting a predefined initialization data files.

Press "F" to select the file selection menu, press "L" and enter a filename; the file "DTV7199" is provided as default setting. Typing "D" would display a directory of available settings.

The software pre-loads all the device parameters, but the actual transmission into the I<sup>2</sup>C device registers is inhibited until the transmission is triggered by typing "T" to select the transmit option and "I" to perform the initialization.

The RGB monitor (respectively the TV monitor) should now show a picture according to the programming as loaded by the file.

Now there is access to all the programming parameters of the selected 'active' devices. Every device is assigned to a page number and can be selected by typing the appropriate function key F1, F2, etc. Subject to the amount of programmable parameters for a certain IC, the page may have sub-pages called sheets, which are accessible with page up/ page down.

Use cursor up/down to select a parameter. Use "+/-" keys of the numeric keypad to change the selected parameter. As long as

transmit function is enabled, the changes of parameters are updated immediately into the device programming registers.

The results of new programming can be studied directly on the monitor screen.

### Loading Look-up Tables of SAA7192A and SAA7199B

Under the programming page of the Digital Color Space Converter SAA7192A, select the "S" special option to load the Video Look-up Tables (VLUT). The sub-menu asks for a filename with the data for the contents of the VLUT. Enter "?" to see the available files or give the desired filename. All files with the extension '.VLT' are data files for VLUT.

Under the pages for the digital encoder SAA7199B one will also find a similar special option "S" sub-menu to load data into the encoders Color Look-up Tables (CLUT). The files that are provided for this purpose carry the extension '.CLT'.

The DVS floppy also contains a utility program SHOW\_LUT.exe, which shows the content of VLT-files as well as CLT-files in a graphic representation. Under DOS just type "SHOW\_LUT filename.CLT".

### Determining I<sup>2</sup>C Register Contents

By means of DVS it is possible to determine the binary or hexadecimal values for the various programming registers for certain programming configurations. These codes can serve as reference for a specific device initialization of a dedicated system, where the programming is drawn from a ROM, PROM or other system file. The software-only

demonstration mode of DVS is especially very helpful for this purpose to obtain the 'compiled' I<sup>2</sup>C register content based on the chosen parameter programming.

The SAA7192A has a single byte for I<sup>2</sup>C programming. The binary representation of the selected programming is directly displayed on that single device page.

For the digital decoders SAA7151B and SAA7191B, as well as the digital encoder SAA7199B, the "special option" is supported by pressing "S". This submenu directly displays the table of the I<sup>2</sup>C registers, displaying the content in binary as well as in hexadecimal representation. For the encoder this table is in the sub-sub-menu Read the section on Registers.

Please note that these tables do not include the I<sup>2</sup>C address and the subaddress/index data required to program the ICs. Refer to the respective data sheets for the exact data protocols for initialization of each device.

### Saving of device and board program settings

It is possible to store the device settings as a data file for use in future sessions. The program saves the settings of all devices in one turn; press "F" to select the file option and "S" to select the save to file option. The user is asked for a file name. the filename must not have any file extension; this is automatically set to '.VAL' by the program. Please make sure that a unique new filename is used to store the setting, otherwise the program will update the device settings of the previously loaded data file as default file.

## DTV7199 Digital Television Demonstration System

### SECTION 11: NOTES

**SOFTWARE:** DVS V. 303 OR LATER  
FOR USE ON PC DOS  
SYSTEMS

UNIVERSAL I<sup>2</sup>C V. 3.2  
OR LATER

MTV CPU (ON BOARD)  
V1.0 OR LATER

1. Do not connect the printer I<sup>2</sup>C adaptor cable to the demonstration board until the microprocessor has sent out the board configuration data after power up.
2. Only install jumpers at JP19 if RTC feature is required.

If jumpers are installed at JP19, then U24 output clock generator, must be removed. The "B" versions of the digital decoder and digital encoder support RTC (Real Time Control). Real time control means that the Digital Encoder SAA7199B, will GENLOCK to the timing signals from the Digital Decoder and clock generator. RTC is a special GENLOCK mode of the Philips Digital Video product family.

3. JP2 selects slave address 8A or 8E for the digital decoder. The microcontroller

transmits data to slave address 8A for the SAA7191 and to slave address 8E for the SAA7151B.

4. The microprocessor may have other menu and programming functions at a future date. If so, the sign-on message will contain new instructions and options as they become available.
5. IC U14 may not be installed from the factory. It can be used to store screen messages and board configuration settings in future software revisions of the onboard microprocessor at U13.
6. A display monitor such as Sony 1342Q or similar is a good choice for evaluating the Y/C, RGB, or Composite Video outputs from the evaluation board. This monitor also displays and decodes PAL if the demo board is reprogrammed.
7. The onboard microprocessor will set up the board for NTSC mode, SAA7199B GENLOCK active, SAA7191 decoder installed, video input composite at JIN2. It is recommended that a reference signal be connected to the GENLOCK input connector at JGL1 so that the digital encoder, SAA7199B, will have a reference.

The reference can be the same video source as the input signal. Double termination of the source signal will be compensated by the automatic gain functions in the TDA8708 A/D converters.

8. High stability GENLOCK even to VCR-type signals is possible with the digital decoder and the digital encoder as well. GENLOCK to VCRs in high speed shuttle or search mode is excellent even for the digital encoder.
9. Real Time Control (RTC) allows the SAA7199B encoder to use sync and clocks from the input section comprised of the SAA7191, SAA7197, and the TDA8708. The SAA7199B does not require the reference crystal or the SAA7197 at location U24 to operate in RTC mode.

RTC signals from the digital decoder transport frequency, phase and other critical timing information about the system clock for other Philips' devices such as the SAA7199B encoder. RTC is a special minimum system configuration feature. It is not a requirement of most applications to make use of RTC.



## DTV7199 Digital Television Demonstration System

## DIVA8 EVALUATION BOARD (Revised May 21, 1992)

REVISION: E

Bill of Materials May 21, 1992

ITEM	QUANTITY	REFERENCE	PART
1	7	C1, C2, C3, C4, C59, C62, C76	3.3 $\mu$ F
2	23	C5, C6, C7, C8, C13, C17, C18, C19, C21, C23, C27, C28, C31, C49, C57, C77, C78, C79, C80, C82, C126, C129, C132	22 $\mu$ F
3	52	C9, C10, C11, C12, C14, C15, C16, C20, C22, C24, C25, C26, C29, C30, C32, C33, C37, C38, C43, C44, C45, C50, C51, C52, C53, C54, C58, C60, C61, C66, C67, C69, C70, C71, C72, C73, C74, C75, C97, C121, C122, C123, C124, C125, C127, C128, C130, C131, C142, C143, C144, C145	0.1 $\mu$ F
4	5	C34, C40, C55, C56, C84	20pF
5	3	C35, C41, C83	30pF
6	2	C36, C42	1 $\mu$ F
7	2	C39, C68	.22 $\mu$ F
8	3	C46, C63, C133	.001 $\mu$ F
9	4	C47, C48, C64, C65	10pF
10	1	C81	220 $\mu$ F
11	12	C85, C88, C89, C92, C93, C96, C109, C112, C113, C116, C117, C120	220pF
12	6	C86, C90, C95, C111, C114, C118	390pF
13	6	C87, C91, C94, C110, C115, C119	560pF
14	2	C134, C135	.01 $\mu$ F
15	3	C136, C137, C138	XXXX
16	3	C139, C140, C141	680pF
17	3	D1, D2, D3	1N4148
18	1	J-8V1	8VDC
19	10	J-BLUE1, J-CHROMA1, J-CVBS1, J-GL1, J-GREEN1, J-IN1, J-RED1, J-SYNC1, J-IN2, J-IN3	BNC
20	1	J-GND1	GND
21	3	J-GND2, J-GND3, J-GND4	GND TP
22	1	J-GND5	J-GND
23	1	J-I <sup>2</sup> C1	4 PIN
24	2	J-SVID1, JSVID2	S-VIDEO
25	3	JP2, JP5, JP13	HEADER 3
26	2	JP3, JP14	HEADER 30X2
27	1	JP6	JUMPER
28	1	JP15	HEADER 8X2
29	2	JP17, JP18	HEADER 2
30	1	JP19	RTC MODE CONTROL
31	1	JP20	H <sub>REF0</sub>
32	9	L1, L2, L3, L4, L5, L6, L7, L8, L13	100 $\mu$ H
33	3	L9, L10, L14	22 $\mu$ H
34	2	L11, L12	10 $\mu$ H
35	15	L15, L16, L17, L18, L19, L20, L21, L22, L23, L24, L25, L26, L27, L28, L29	2.7 $\mu$ H
36	2	Q1, Q2	PN2222
37	7	R1, R2, R3, R4, R7, R30, R36	75
38	13	R5, R6, R10, R11, R19, R20, R21, R22, R23, R32, R39, R50, R51	10K

# DTV7199 Digital Television Demonstration System

## DIVA8 EVALUATION BOARD (Continued) (Revised May 21, 1992)

ITEM	QUANTITY	REFERENCE	PART
39	6	R8, R9, R13, R14, R33, R34	750
40	4	R12, R15, R35, R41	330
41	4	R16, R37, R59, R60	22
42	1	R17	47K
43	13	RP1, RP2, R18, R24, R25, R27, R28, R45, R53, R54, R55, R56, R58	4.7K
44	1	R26	10
45	2	R29, R40	1.5K
46	1	R31	33K
47	1	R38	680K
48	3	R42, R43, R44	30
49	3	R46, R47, R48	15
50	1	R49	15K
51	1	R52	6.8K
52	1	R57	100K
53	1	RP3	10KX6
54	1	S1	SW SPST
55	4	S2, S3, S4, S5	SW PUSHBUTTON
56	1	U1	TDA8709
57	2	U2, U23	TDA8708
58	2	U3, U24	SAA7197
59	1	U4	SAA7191B
60	8	U5, U6, U7, U8, U9, U10, U11, U12	TMS4C1050
61	1	U13	S87C054
62	1	U14	PCF8582E
63	9	U15, U16, U17, U20, U26, U31, U51, U53, U54	74HC74
64	3	U18, U19, U21	74HC27
65	1	U22	SAA7199B
66	1	U25	74HC04
67	1	U27	74HC00
68	2	U28, U29	74HC163
69	1	U30	74HC10
70	1	U32	74HC30
71	3	U47, U48, U49	74HCT243
72	1	U50	SAA7169
73	1	U52	SAA7192A
74	2	VR1, VR2	7805
75	2	Y1, Y3	26.800
76	1	Y2	10MHz

# DTV7199 Digital Television Demonstration System

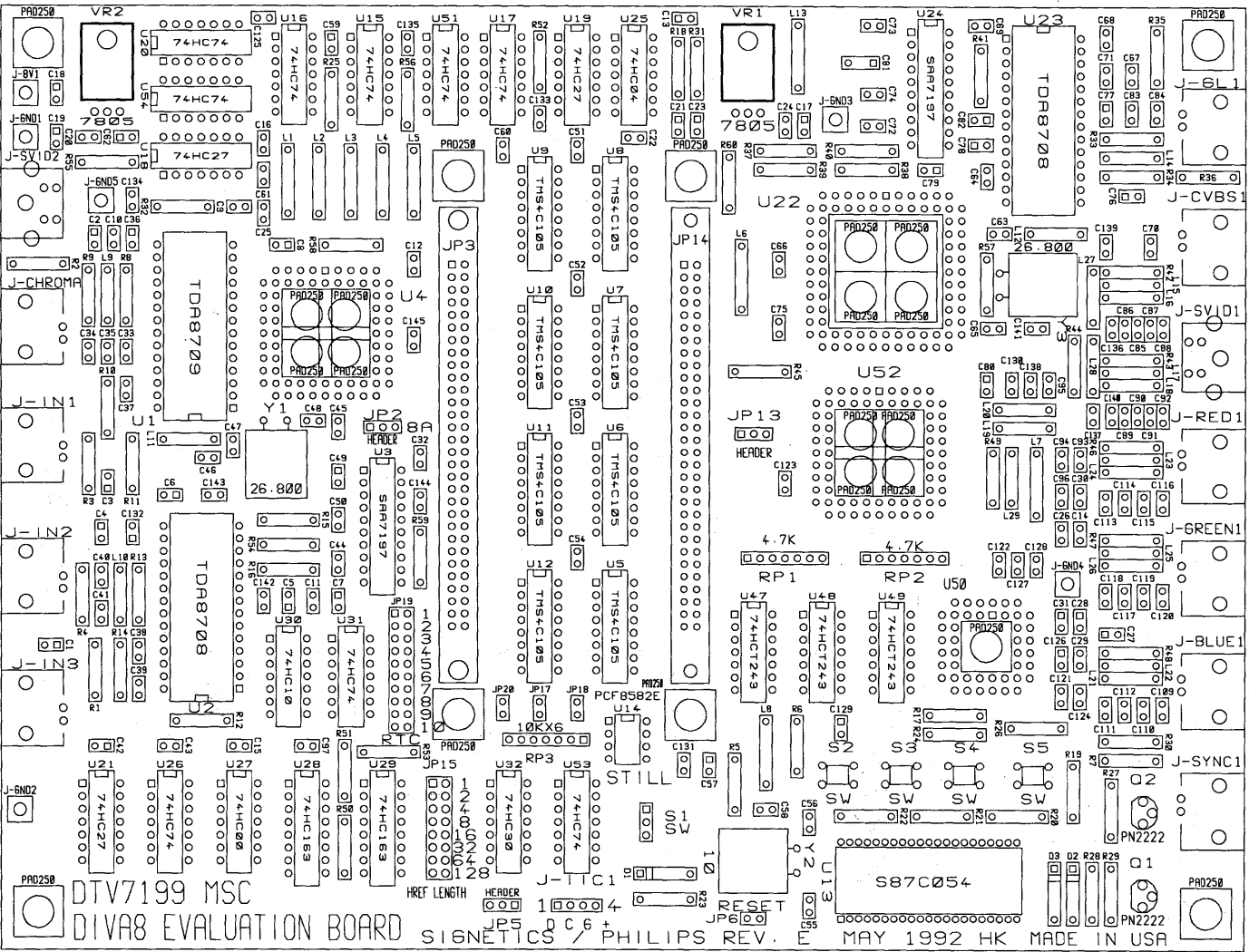

# DTV7199 Digital Television Demonstration System

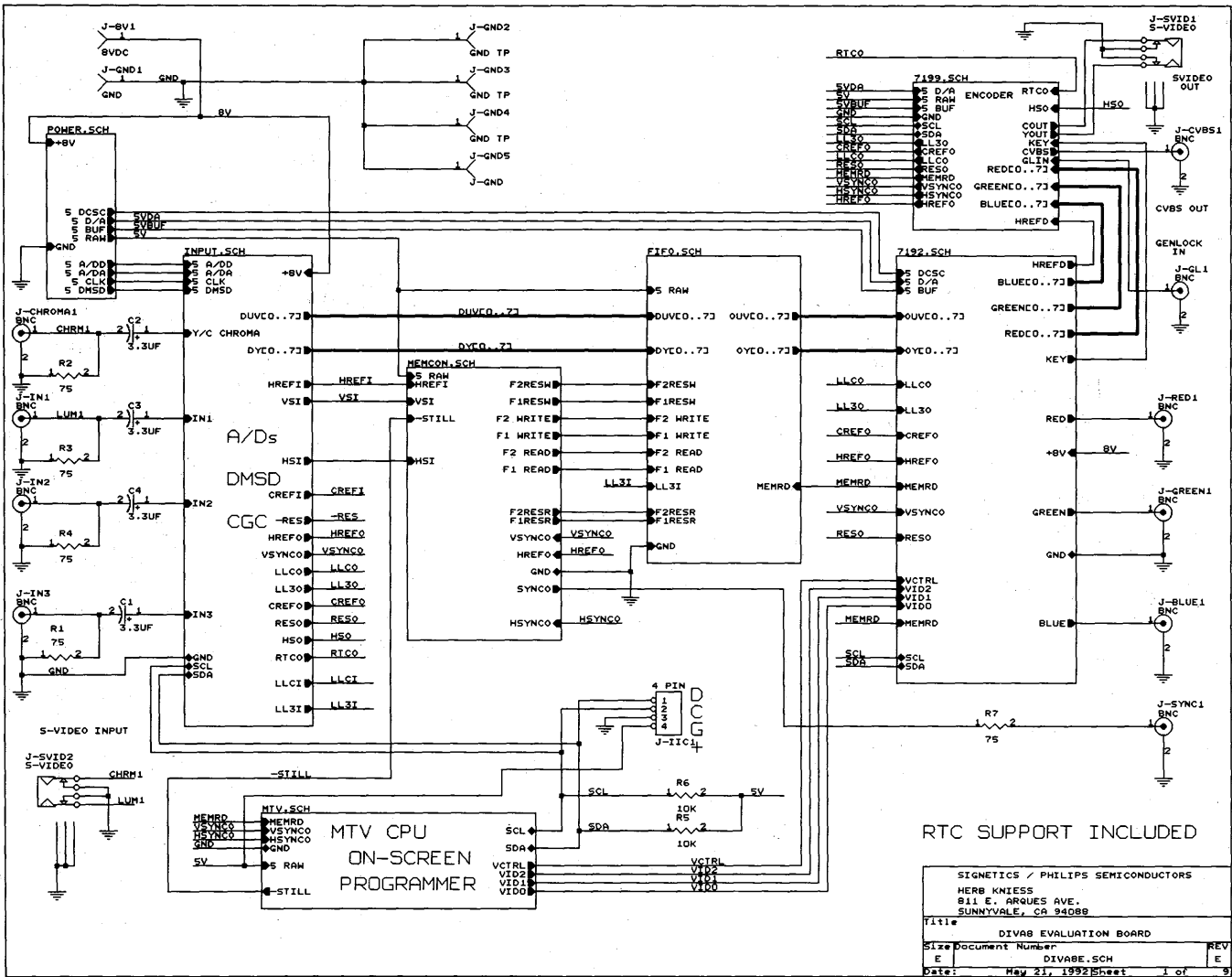

RTC SUPPORT INCLUDED

SIGNETICS / PHILIPS SEMICONDUCTORS  
 HERB KNISS  
 811 E. ARQUES AVE.  
 SUNNYVALE, CA 94088

Title DIVAS EVALUATION BOARD  
 Size Document Number DIVABE.SCH REV E  
 Date: May 21, 1992 Sheet 1 of 9

# DTV7199 Digital Television Demonstration System

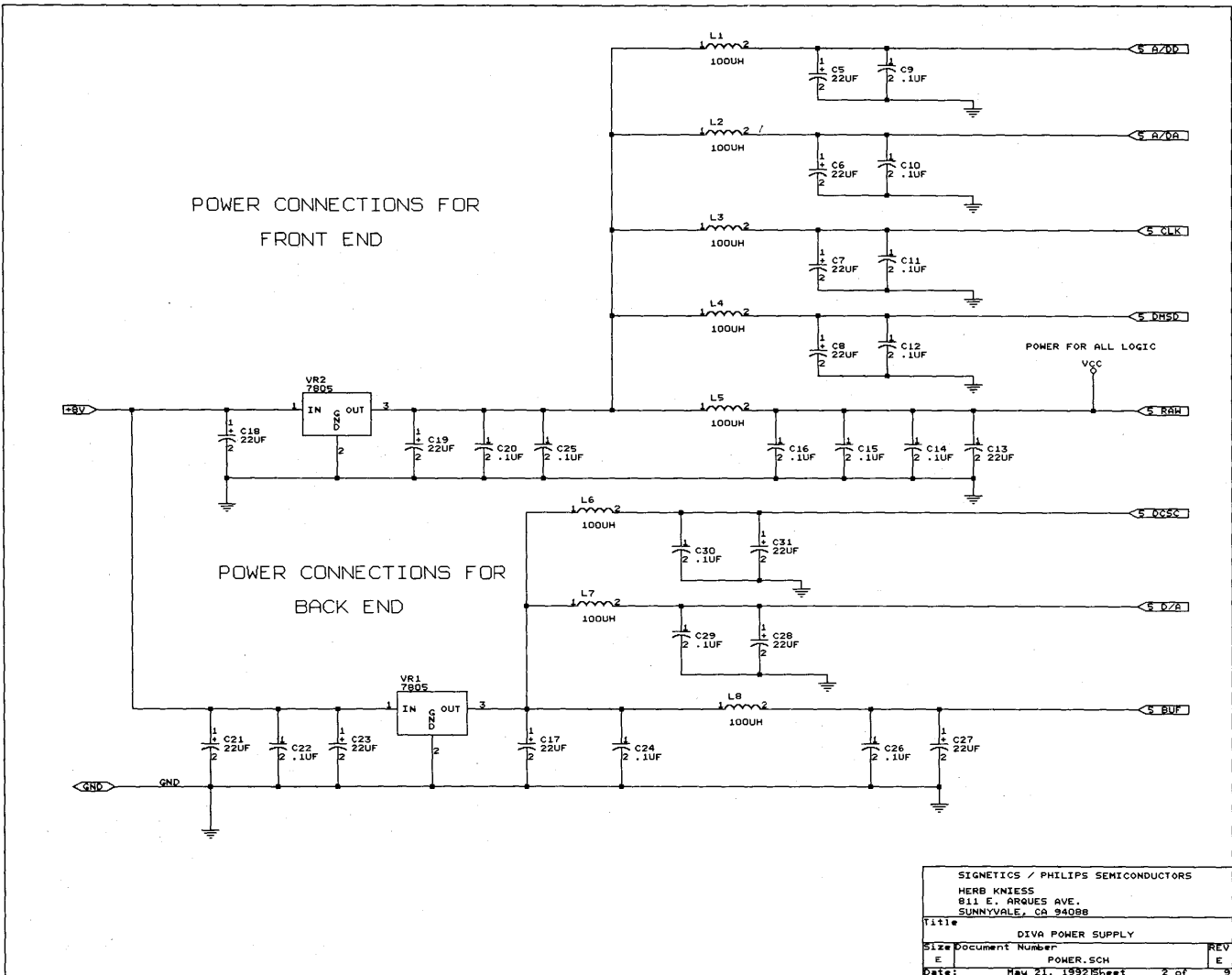

SIGNETICS / PHILIPS SEMICONDUCTORS	
HERB KNISS 811 E. ARQUES AVE. SUNNYVALE, CA 94088	
Title DIVA POWER SUPPLY	
Size Document Number	REV
E POWER.SCH	E
Date: May 21, 1992	Sheet 2 of 3

# DTV7199 Digital Television Demonstration System

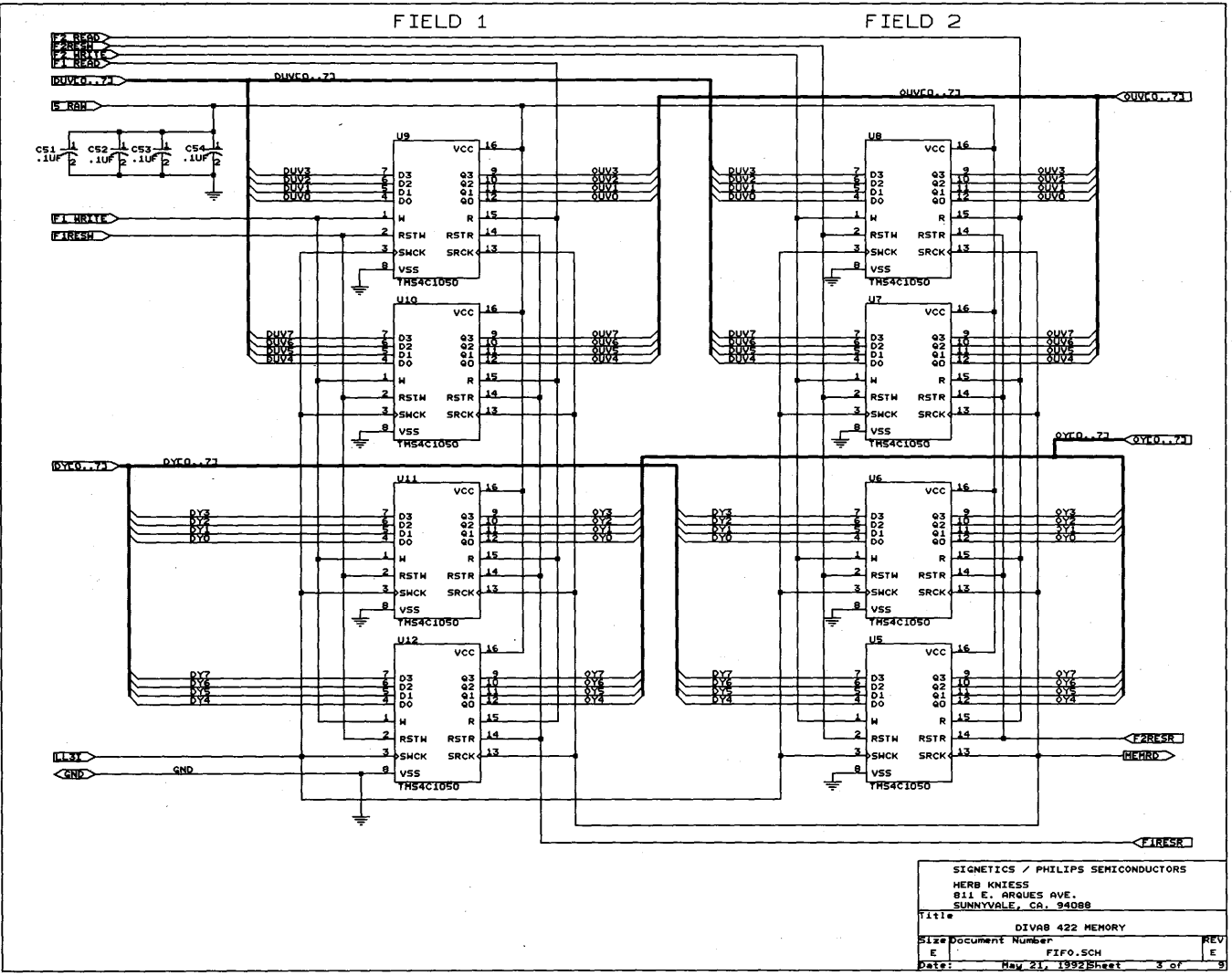

STIGNETICS / PHILIPS SEMICONDUCTORS	
HERB KNISS	
811 E. ARGUES AVE.	
SUNNYVALE, CA. 94088	
Title	DIV48 422 MEMORY
Size	Document Number
E	FIFO.SCH
Date	May 21, 1992 Sheet 3 of 3

# DTV7199 Digital Television Demonstration System

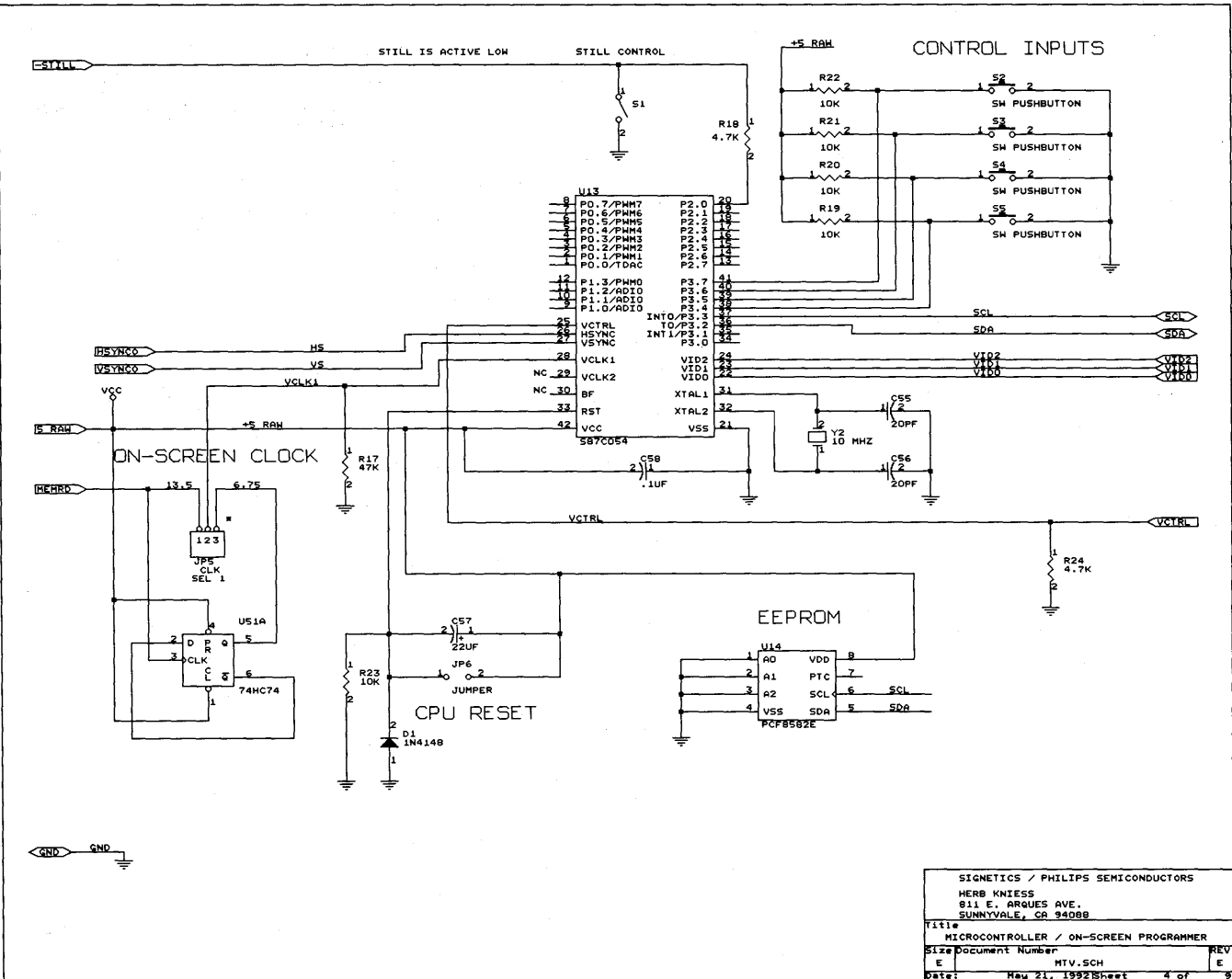

# DTV7199 Digital Television Demonstration System

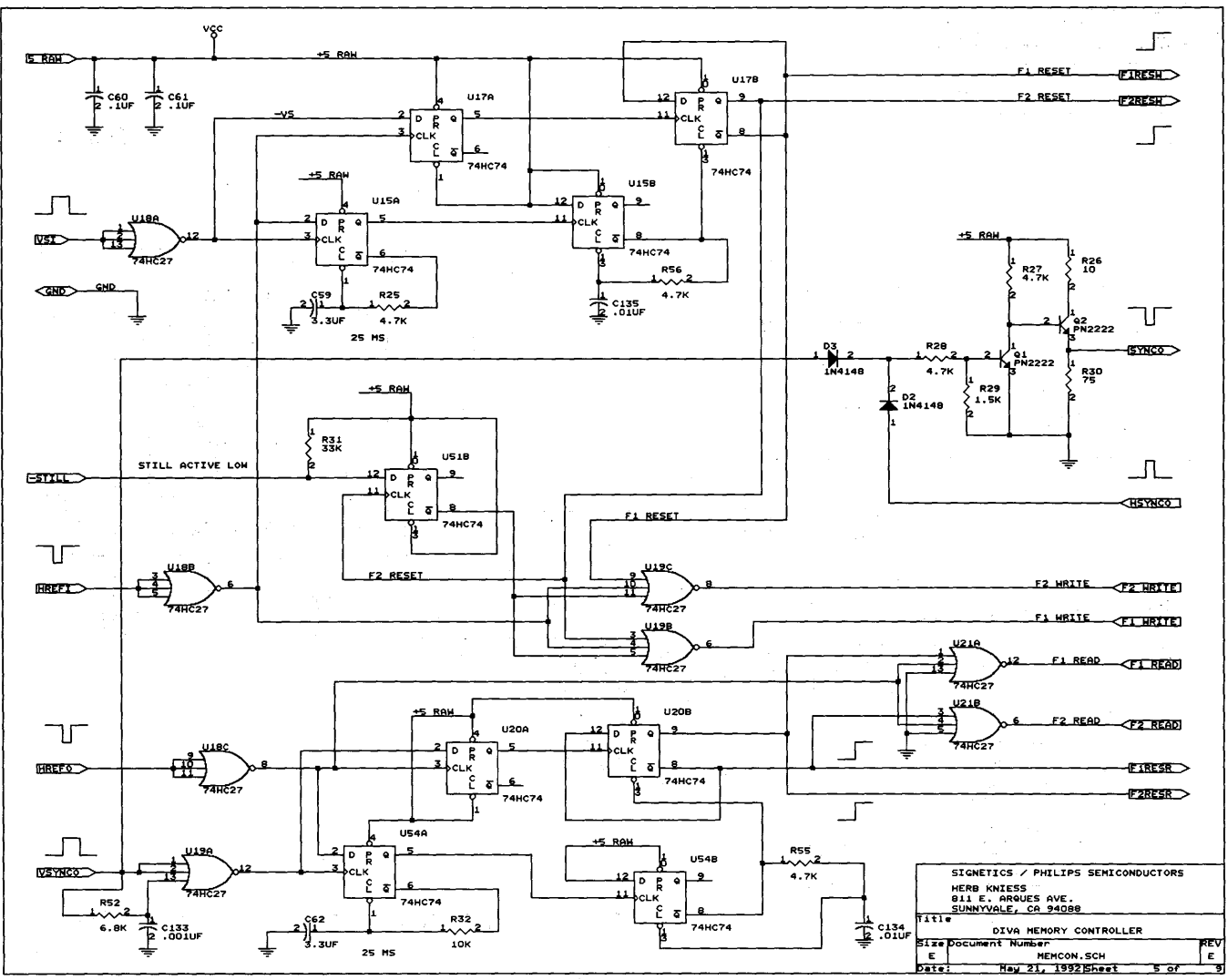

SIGNETICS / PHILIPS SEMICONDUCTORS  
 HERB KNEISS  
 811 E. ARGUS AVE.  
 SUNNYVALE, CA 94088

Title: DIVA MEMORY CONTROLLER  
 Size: Document Number MEMCON.SCH REV E  
 Date: May 21, 1992 Sheet 5 of 9





# DTV7199 Digital Television Demonstration System

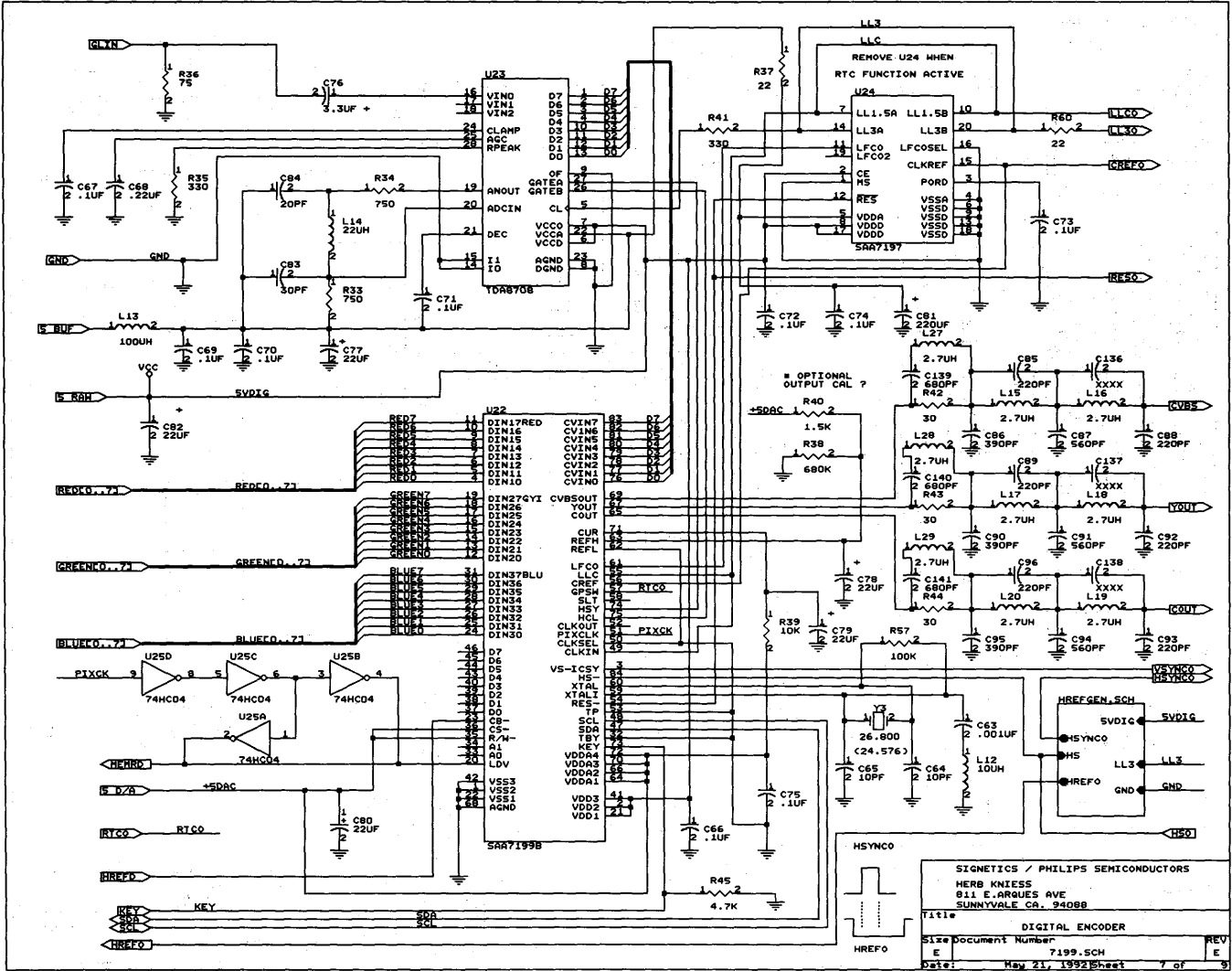

# DTV1799 Digital Television Demonstration System

## HREF GENERATOR

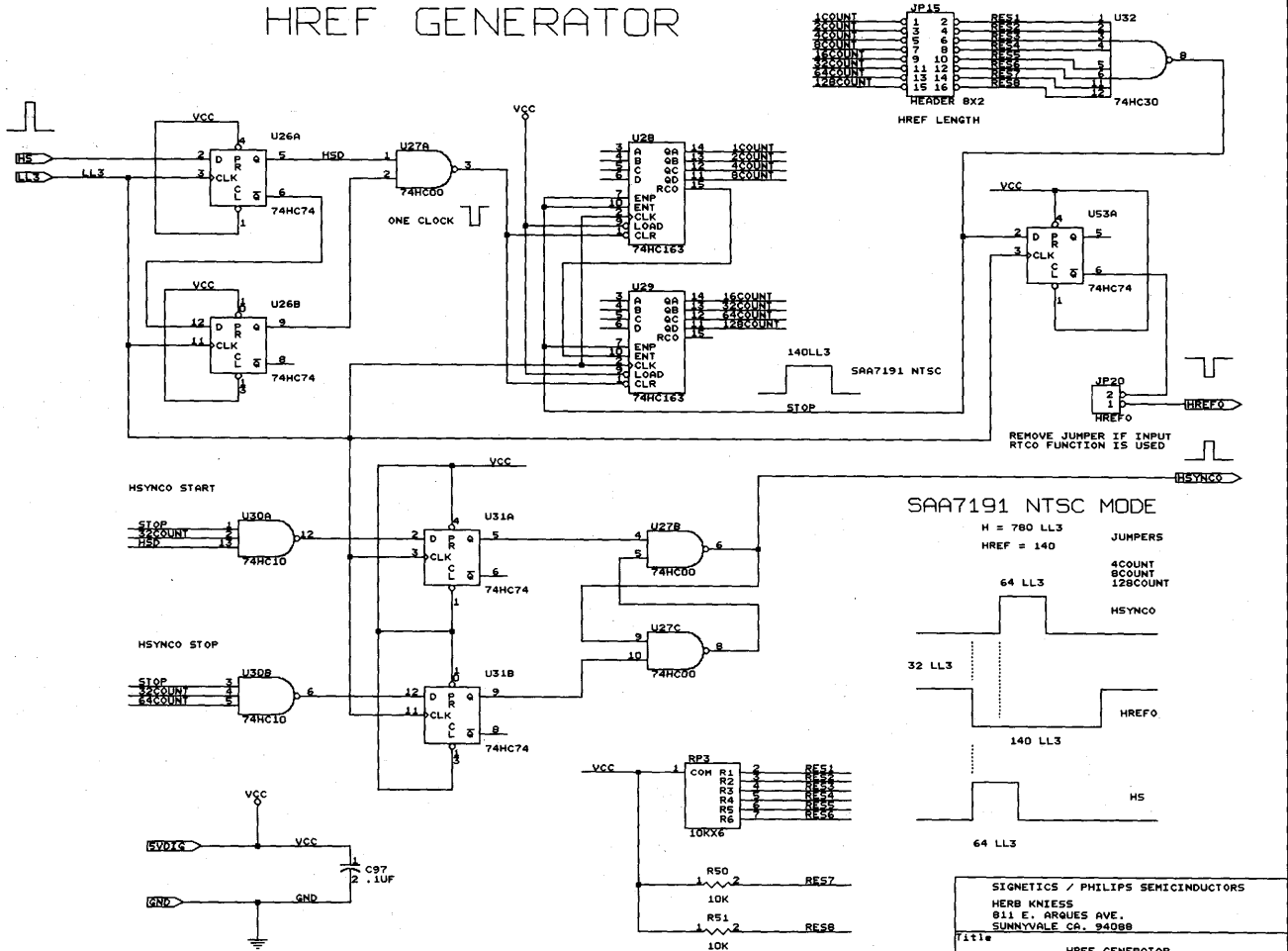

SIGNETICS / PHILIPS SEMICONDUCTORS  
HERB KNISS  
811 E. ARGUES AVE.  
SUNNYVALE CA. 94088

Title: HREF GENERATOR  
Size: Document Number: REV  
E HREFGEN.SCH E  
Date: May 21, 1992 Sheet 8 of 9

# DTV7199 Digital Television Demonstration System

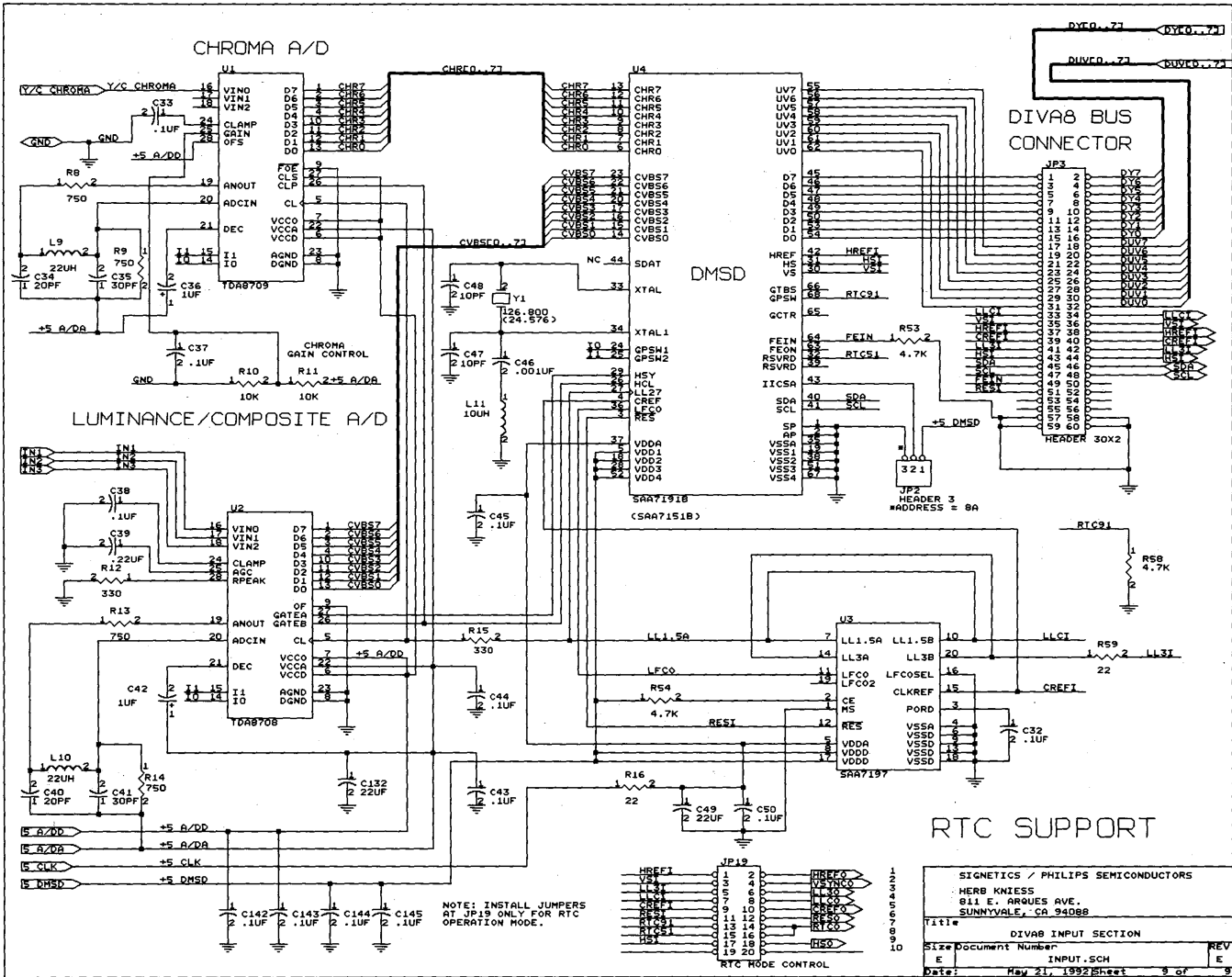

SIGNETICS / PHILIPS SEMICONDUCTORS	
HERB KNISS 811 E. ARQUES AVE. SUNNYVALE, CA 94088	
Title	DIVA8 INPUT SECTION
Size	Document Number
E	INPUT.SCH
Date:	May 21, 1992 Sheet 3 of 9

# DTV7199 Digital Television Demonstration System

## APPENDIX TO DTV7199 APPLICATION NOTE

### Measurements on SAA7199B

The digital encoder SAA7199B is brought into slave mode and a digital pattern generator is applied to feed the data to the encoder's input. With a test pattern according to CCIR test procedure 100% luminance (white) and 75% color saturation (see application note "Digital interface for component video signals") a standard color bar test signal is generated. Figure 1 shows the measurement

on Tektronix 521A vectorscope for a PAL signal under a 13.5MHz clock (CCIR 601). The color dots are clearly in the target boxes. The small deviations (spot size and angle) are in the accuracy limitations of an 8-bit representation of video baseband signals.

Figure 2 shows the transients for 100% color saturation in primary colors by means of a multiple color sawtooth test signal. This test signal, shown in Figure 3 in its time domain,

provides luminance ramps and color saturation (envelope) ramps together. It supports differential phase measurement with real video specific constraints (no saturation at black). The result of such a check is shown in Figure 4. The differential phase error is less than 1.5 degrees peak-to-peak. The CCIR color bar tolerance boxes are about four times as large.

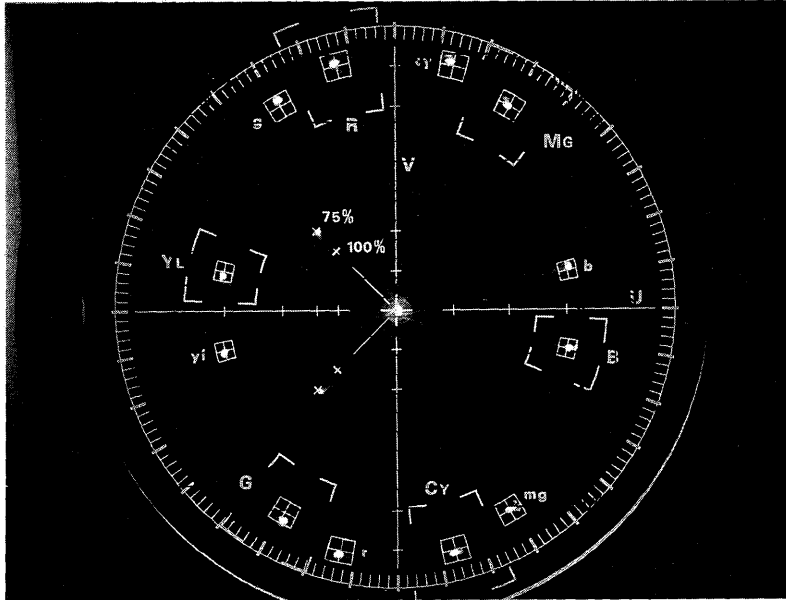

Figure 1. Color bar test signal on the vectorscope

# DTV7199 Digital Television Demonstration System

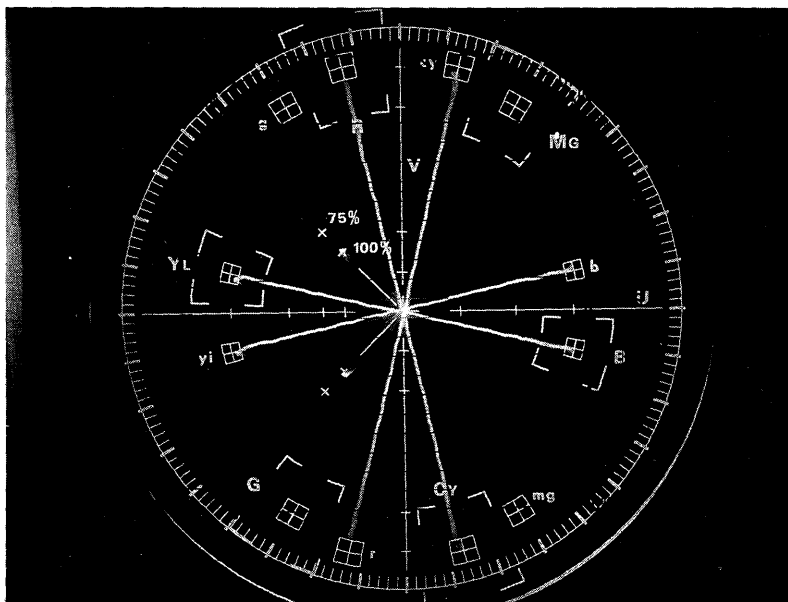

Figure 2. Color transients

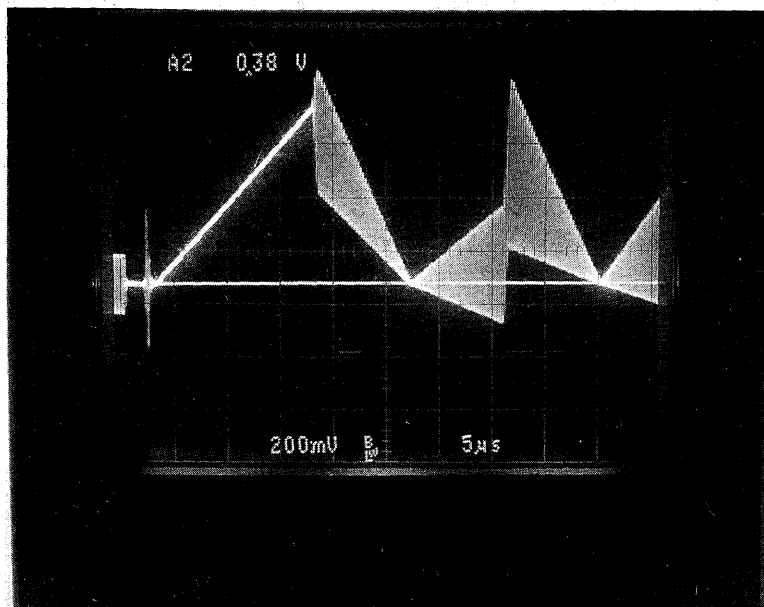

Figure 3. Color and luminance ramps combined signal

# DTV7199 Digital Television Demonstration System

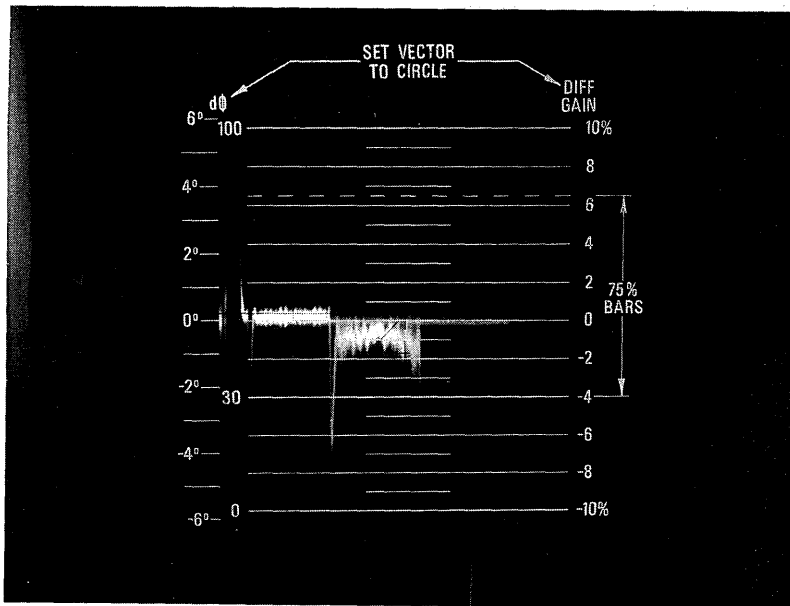

Figure 4. Differential phase measurement

# DTV7199 Digital Television Demonstration System

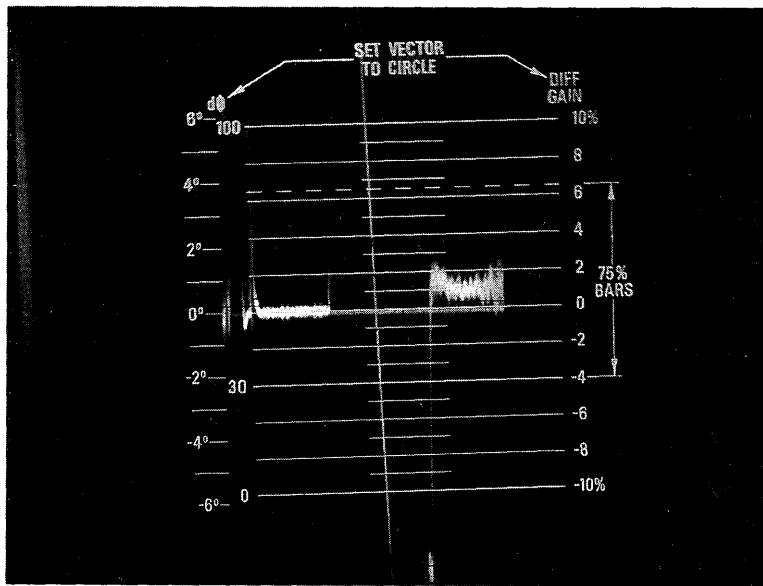

Figure 5. Differential phase measurement  
Second color ramp



## SAA7199B operational modes

Author: Herb Kniess

### INTRODUCTION

The SAA7199B Digital Video Signal Encoder can be configured to operate in one of four different modes. Each operation mode has different system cost and interface considerations. One or more modes may be implemented for each application depending on system requirements and hardware interfaces. This note describes the different hardware configurations for the different modes and also the available timing programmabilities.

### GENLOCK MODE

In many system applications it is necessary to GENLOCK the CVBS video output of the encoder to a master timing reference. It is necessary in GENLOCK MODE to adjust the horizontal sync and subcarrier phase relative to the master reference in order to compensate for external phase shift or signal delays in cable connections. The SAA7199B can GENLOCK to stable references and also to signals with time base errors such as signals from consumer VCRs. As all signals including the subcarrier will follow the reference signal, RS170A cannot be enforced automatically; if the reference is standard, the encoded CVBS will be standard. See Figure 1 for connection diagram.

GENLOCK mode can be turned off via I<sup>2</sup>C control register in the absence of a reference sync signal and the sync-to-clock PLL will assume the nominal default frequency (see Stand Alone Mode). In GENLOCK mode it is necessary to digitize the reference signal using the TDA8708 A/D converter. The TDA8708 A/D converter is operated at normal data rates, not 2x, as in applications with the 8-bit digital decoders. The SAA7197 clock generator is used to assist in generation of the system clock. A stable crystal reference completes the GENLOCK configuration. An external stable clock could be supplied at Pin 59 instead of the crystal oscillator. It is important to note that in GENLOCK mode the SAA7199B will precisely follow the sync and subcarrier phase of the reference signal. The SAA7199B generates all sync, clock, and timing signals to strobe and trigger the data source. The SAA7199B supports that by extensive programmability.

Input data, e.g., from a frame buffer memory, must be supplied when requested so that encoded signals will be available on DAC outputs in time with the reference signal. Data inputs to the encoder must be supplied ahead of the analog output sync signal because of internal pipe line delays of 55 clocks. The horizontal sync (HSN) on Pin 84 can be programmed relative to the reference

signal to compensate for memory access delays and the 55 clock pipeline delay in the encoder (see also the chapter on Timing later in this application note). The composite blanking CBN must be supplied to Pin 23 as an input to synchronize data handling. Pin 3 VS/CSY is normally programmed as vertical output to be used as a reset for memory controllers at the beginning of a field at line 6. A single clock system is shown for convenience and ease of interface (for the double clock system, please refer to the datasheet). IC 3A and 3B delay the system clock by at least 8ns at Pins 55 and 49 to follow the LDV clock requirements. LDV latches data from the signal data source.

### STAND ALONE MODE

STAND ALONE MODE is a simplified version relative to GENLOCK mode but shows the same data input interface. The TDA8708 A/D converter is not used and stable sync and timing signals are always generated by the SAA7199B based on a stable clock. Since the subcarrier frequency is also synthesized out of this clock frequency, the clock needs to have sufficient accuracy and stability to ensure RS1970A standard. It is an option to let the clock be generated by the SAA7199B itself in conjunction with a SAA7197 and a crystal.

The crystal reference frequency is 24.576MHz for CCIR system or 26.8MHz for square pixel system, but only one crystal for PAL or NTSC. CCIR-624 specifies - as broadcast requirement - a tolerance of 5ppm (NTSC) respectively 2ppm (PAL), but regular consumer-like equipment except static deviations of 50ppm or more. By means of FSC(0...7) in programming register index-0D frequency offset in the crystal reference can be compensated in the range of  $\pm 450$ ppm in steps of 2ppm. An external stable reference clock could be used at Pin 59 instead of the crystal oscillator. See Figure 2 for connection diagram. U2A and U2B is used again to delay the main encoder clocks relative to LDV about 10ns. LDV latches data from memory.

### SLAVE MODE

All timing signals such as sync, clocks, and blanking are provided by external sources. The clocks must be crystal stable, without exception.

Note the clock delay through U1A and U1B of about 10ns. No other components are required because the external source provides all timing information. Pin 59 XTALI should be grounded because the reference crystal is not needed. Figure 3 shows pin connections and signal directions. The output

analog sync will contain proper equalizing, serration, and burst blanking signals even if they are not contained on input sync signals.

As an option, the clock may be generated by the SAA7199A in conjunction with SAA7197 and a reference crystal (see Stand Alone Mode).

### REMOTE GENLOCK (RTC MODE)

RTC MODE (Real Time Control) is an exclusive feature of Philips Digital Decoders and Digital Encoders. Pin 57 (RTC!) must be programmed and connected to a SAA7191B or SAA7151B digital decoder RTCO pin. In RTC mode the digital decoder front end provides all timing information including the clock to the SAA7199B. The clock frequency may vary, especially since a digital decoder could be locking to a VCR source. However, with the connection of RTCO from a decoder, the encoded subcarrier in the SAA7199B will be stabilized even with VCR sources as inputs. RTC and the DMSDs LLC-clock can be applied to the SAA7199B under stand alone, as well as slave mode. The connection block diagram is shown in Figure 4. Note the clock delay through U3A and U3B of about 10ns.

RTC MODE allows a complete decoding and encoding system to be configured with only four processing devices. The following ICs are required as the minimum configuration:

1. TDA8708 A/D Converter
2. SAA7151B or SAA7191B Digital Decoder
3. SAA7157 or SAA7197 Clock Generator
4. SAA7199B Digital Encoder

The RTC line contains valuable data about the system clock phase and frequency and related subcarrier information generated within the decoder during the color demodulation process. The data is updated every line and coded in a serialized protocol; protocol start is self-synchronizing, i.e., sender and receiver can have different line-sync phase.

When a SAA7199B is connected directly to the decoder clock system, it is possible to encode stable subcarrier even with variable but line-loaded system clocks from the decoding front end. The output sync and subcarrier from the encoder will have the same timing (standard or non-standard) as the input demodulated signals (standard or non-standard) in front of the decoder. The digitized CVBS in front of the DMSD can be applied to the CVBS input Pins (76-83) of the SAA7199B to be used with the CVBS key function. The timing programming range of HS as DMSD output and HSN as DENCs

## SAA7199B operational modes

input allows direct sync-coupling. The subcarrier phase is adjustable via programming as needed by the application purpose. The DP inputs of the SAA7199B may carry manipulated or other video overlay data. With a memory buffer included in the system between DMSD and DENC, the sync timing can be different in phase than the accumulated data processing delay of about 150 clocks, but will remain constant because the clocks are the same.

### DATA, BLANKING, AND SYNC TIMING

#### Processing Delay and Programmable Timing

Depending on the different operation modes of the digital encoder SAA7199B, the timing – from the digital input side to the analog output respectively to the analog CVBS reference – can be programmed in different ways.

Figure 5 is a reprint of Figure 10 from the SAA7199B data sheet; it shows the timing of input data and sync to output representing that sync and data. There is a constant 55 pixel clock pipeline delay from input data to analog output signals. The horizontal sync-signal HSN at Pin 84 can be an input or an output depending on the selected operational mode of the encoder. The relative timing of HSN to the analog output sync is programmable for input as well as for output modes.

Composite blanking CBN at Pin 23 must have a rising edge at the beginning of active data to ensure proper operation of the UV format demultiplexer and also to remove the blanking condition. Video blanking is forced during vertical and horizontal blanking regardless of the state of CBN signal of Pin 23.

#### Output Timing to GENLOCK Reference Input

The SAA7199B has an internal timing machine which generates all timing and gating signals to generate the proper sync pulse position (phase), sync pulse duration, sync slopes, default blanking, burst gate position and length as well as burst envelope (shaping) for all possible clock frequencies and video standards to be selected. The result of that can be seen in the CVBS output signal- or Y-C outputs at Pins 69, 67 and 65.

In GENLOCK mode the DENC refers its internal timing machine to the digital CVBS signal (applied to the Pins 76 to 83). The DENC investigates that external CVBS, detects the slope of the horizontal synchronization pulse, and locks phase and frequency of the clock via SAA7197 and sampling ADC TDA8708 to this reference  $t_{REF1}$  (Line-Locked-Clock system). Beyond that it is possible to program a constant time offset between sync-pulse of the reference  $t_{REF1}$  and sync-pulse of the CVBS output, respectively the Y-C outputs (compare Figure 5), but maintaining the Line-Locked-Clock feature. By programming the GDC-bits in register index-05 to zero the CVBS output is 17 pixel clock cycles later than the reference CVBS; programming GDC to 17 decimal (11 hexadecimal) brings reference and CVBS output into identical phase. Increasing the GDC value up to 63 decimal (3F hexadecimal) brings the internal timing scheme and the output CVBS in advance of the reference input by up to 46 pixel clock cycles earlier.

Independent of this GENLOCK-delay programming via GDC, it is also possible to adjust the subcarrier phase of the output relative to the subcarrier phase at the reference input. The programming byte CHPS(0..7) in register index-0C covers the

whole cycle of 360 degrees in 256 steps, which means 1.4 degree each step.

The adjustment of GENLOCK-delay and subcarrier phase offset is relevant in an application where the generated DENC output is further processed and mixed with other video signals for editing purposes. Also for modulating multiple video sources onto one cable or for broadcasting by air a well-defined phase relationship of these signals is necessary in order to keep channel cross-talk under control.

#### CBN and $t_{REF2}$

The processing (pipeline) delay  $t_{ENC}$  from digital data input to analog output is constant under all modes, input formats, clocks and other programming conditions and is 55 pixel clocks (compare Figure 5). Data fed into the digital input ports DPn (n=1,2,3) are visible 55 pixel clock cycles later in the analog video output signal. Figure 5 shows the composite blanking input CBN in nominal standard form; CBN may claim a wider blanking period if less data than the nominal active pixels per line are available. The same processing delay  $t_{ENC} = 55$  pixel clocks ahead of the leading slope of the CVBS output signal is the reference point for the leading edge of the (imaginary) sync pulse at the data input. In Figure 5 this point is signed with  $t_{REF2}$ . The different standard requirements for NTSC and PAL and the various possible clock frequencies result in different number of clock pulses for the nominal blanking period, and for the time from the start of sync to the end of line blanking. Table 1 lists the relevant numbers. The number for nominal line blanking period is implemented via the internal timing machine as default; it cannot be shortened, but blanking can be extended by CBN at Pin 23. The rising slope of CBN also synchronizes the UV format demultiplex sequence.

Table 1. Standards and Number of Clocks

STANDARD SYSTEM	PIXEL CLOCK (MHZ)	CLOCKS PER LINE	ACTIVE PIXELS	LINE BLANKING (PIX-CL)	SYNC START TO ACTIVE LINE	LINE PERIOD ( $\mu$ S)	BLANKING PERIOD ( $\mu$ S)
NTSC-SQP	12.273	780	640	140	125	63.56	11.41
PAL-SQP	14.750	944	768	176	163	64	11.93
NTSC-CCIR	13.500	858	720	138	122	63.56	10.22
PAL-CCIR	13.500	864	720	144	134	64	10.67

## SAA7199B operational modes

### HSN, VSN as output (GENLOCK, stand-alone)

In stand-alone mode as well as in GENLOCK mode the SAA7199B outputs an HSN signal at Pin 84 and a VSN/CSYN signal at Pin 3, in order to provide the signal source (graphic- or pattern-generator, memory controller) with a timing trigger signal. In order to compensate for unspecified delays in that peripheral controller, the actual position (phase) of HSN output is programmable over a range of 64 pixel clock cycles by means of the PSO-bits in register index-07. Programming PSO to "00" generates an HSN with a leading edge that is 58 pixel clock periods earlier than the nominal position  $t_{REF2}$ ; "3F hex" = "63 dec" as PSO makes an HSN that is 5 pixel clock cycles after  $t_{REF2}$ . The leading edge of VSN-output, of the combined composite sync CSYN-output follows this programming of the PSO-bits to always coincide with HSN in the same clock period.

The pulse width of HSN output is always 64 clock cycles. The polarities of HSN, VSN or CSYN are independently programmable via the bits SYSEL0 and SYSEL1 in register index-04. These two bits also control whether the signal at Pin 3 acts as VS block vertical sync or as composite sync. The HSN signal form as shown in Figure 5 is called "active LOW" and requires a programming of 01 bin in SYSEL.

### HSN, VSN as input (slave mode)

In slave mode, the SAA7199B requires that all sync and clock signals come from an external source. The clock frequency is supposed to be accurate and stable enough to enable the DENC to generate a proper subcarrier frequency. The clock frequency is also supposed to be line-locked, so that there is always the nominal number of clock cycles between two horizontal sync pulses.

HSN (Pin 84) and VSN/CSYN (Pin 3) act as inputs. The nominal phase relative to CBN and input data is shown in Figure 5 as  $t_{REF2}$ . Table 1 gives the times from (imaginary) sync pulse start to start of active line (end of nominal line blanking) at the DENC's input for the various standards and clock frequencies. The leading edge of the incoming sync pulse HSN triggers the internal timing machine. A minimum pulse width of one pixel clock period is required.

In order to compensate for unspecified delays in the controller for the signal source, the actual position of HSN input relative to reference point  $t_{REF2}$  is programmable over a range of 64 pixel clock cycles by means of the GDC bits in register index-05. This is not the register defining the timing offset of HSN as output, but the one to be used in GENLOCK mode to program reference to output "GENLOCK delay". Programming GDC to "00" enables the DENC to accept an HSN-input with a leading edge that is 17 pixel clock periods earlier than the nominal position  $t_{REF2}$ . If HSN-input leading edge is in phase with  $t_{REF2}$  GDC needs to be programmed with "17 dec" (11 hexadecimal); "3F hex" = "63 dec" supports an HSN-input with a leading edge that is 46 pixel clock cycles later  $t_{REF2}$ . The leading edge of VSN-output, of the combined composite sync CSYN-output follows programming of the GDC bits to coincide always with HSN in the very same clock period.

### MULTI-PURPOSE KEY AND INPUT FORMATS

The digital encoder SAA7199B has three digital data input ports, each 8-bits wide, and named DP1, DP2 and DP3. There are seven

basic input formats accepted; see Tables 10 to 16 in the data sheet. Beyond the basic format definition, the data stream can be transformed via look-up tables. The look-up tables can be used for any kind of linear or non-linear amplitude processing, as in a gain in YUV or gamma correction in RGB. CCIR-601 specifies the number range for luminance signal from 16 (black) to 235 (100% white) and for the color difference signals U and V (75% saturation) from 44 to 212. In the Philips DTV system, some slightly different numbers are chosen (DMSD-2 levels) in order to get better usage of the available 8-bit number range and to minimize truncation noise and visibility of signal limiting (clipping) artifacts. Luminance goes from 12 (black) to 230 (100% white) and provides more room for superwhite overshoots. The color difference signals are coded in two's complement and use about 20% more number range, which enhances color resolution. Refer also to the SAA7151B data sheet, Figures 5 and 6.

The SAA7199B has a CVBS KEY function, controlled by Pin 73 to insert (pixel by pixel) the reference CVBS signal in realtime into the encoded CVBS output signal. In addition, realtime input format switching is supported by means of the MPK function (Multi-Purpose Keying). Table 2, MPK-Pin and Input Formats, gives a comprehensive overview of the realtime switching possibilities by MPK at Pin 32. Two different input formats are defined simultaneously via software programming and can be mixed on a pixel-by-pixel basis at the DP input pins. For example it can be switched from any YUV format to RGB 24-bit or indexed color, or between RGB with and without look-up table.

## SAA7199B operational modes

Table 2. MPK-Pin and Input Formats

MPK PIN #32	PROGRAM-BYTE							SELECTED:		
	INDEX 00HEX					INDEX 09HEX		FORMAT #	LUTs	LEVELS ACC. TO
	D7 VTBY	D6 FMT2	D5 FMT1	D3 FMT0	D2 CCIR	D5 MPKC1	D4 MPKC0			
LOW	(*)	0	0	0	(*)	X	X	#0	(*)	(*)
LOW	(*)	0	0	1	(*)	X	X	#1	(*)	(*)
LOW	(*)	0	1	0	(*)	X	X	#2	(*)	(*)
LOW	(*)	0	1	1	(*)	X	X	#3	(*)	(*)
LOW	(*)	1	0	0	(*)	X	X	#4	(*)	(*)
LOW	(*)	1	0	1	1	X	X	#5	(*)	CCIR
LOW	X	1	1	0	X	X	X	NOT USED		
LOW	0	1	1	1	1	X	X	#7	8 → 24	CCIR
HIGH	X	0	0	0	(*)	0	0	#0	BYPASS	(*)
HIGH	X	0	0	1	(*)	0	0	#1	BYPASS	(*)
HIGH	X	0	1	0	(*)	0	0	#2	BYPASS	(*)
HIGH	X	0	1	1	(*)	0	0	#3	BYPASS	(*)
HIGH	X	1	0	0	(*)	0	0	#4	BYPASS	(*)
HIGH	X	1	0	1	1	0	0	#5	BYPASS	CCIR
HIGH	X	1	1	0	X	0	0	NOT USED		
HIGH	X	1	1	1	1	0	0	#7	8 → 24	CCIR
HIGH	X	X	X	X	X	0	1	#5	ACTIVE	CCIR
HIGH	X	X	X	X	X	1	0	DONT USE		
HIGH	X	X	X	X	X	1	1	#7	8 → 24	CCIR

## NOTES:

X = don't care

(\*) → see table about VTBY and CCIR programming bits

HIGH = TTL level high, i.e., &gt; 2.0V

LOW = TTL level low, i.e., &lt; 0.8V

LUTs: BYPASS = Look-up tables not in signal path

ACTIVE = the three RAM-tables are used independently as three 8-bit → 24-bit Look-up tables in the three channels RGB or

YUV

8 → 24 = the RAM-block is used as one 8-bit → 24-bit look-up table to transform indexed or palettized 8-bit color into 24-bit color

## SAA7199B operational modes

**Table 3. VTBY and CCIR Bits**

MPK PIN #32	PROGRAM-BYTE				SELECTED:	
	INDEX 00HEX		INDEX 09HEX		LUTs	LEVELS ACC. TO
	D7 VTBY	D2 CCIR	D5 MPKC1	D4 MPKC0		
LOW	0		X	X	IN DATA-PATH	
LOW	1		X	X	IN BYPASS	
LOW		0	X	X		DMSD-2
LOW		1	X	X		CCIR 601
HIGH	X		0	0	IN DATA-PATH	
HIGH	X	0	0	0		DMSD-2
HIGH	X	1	0	0		CCIR 601
HIGH	X	X	0	1	IN DATA-PATH	CCIR 601
HIGH	X	X	1	0	DON'T USE	DON'T USE
HIGH	X	X	1	1	8 → 24 BITS	CCIR 601

**NOTES:**

X = don't care

HIGH = TTL level high, i.e., > 2.0V

LOW = TTL level low, i.e., < 0.8V

# SAA7199B operational modes

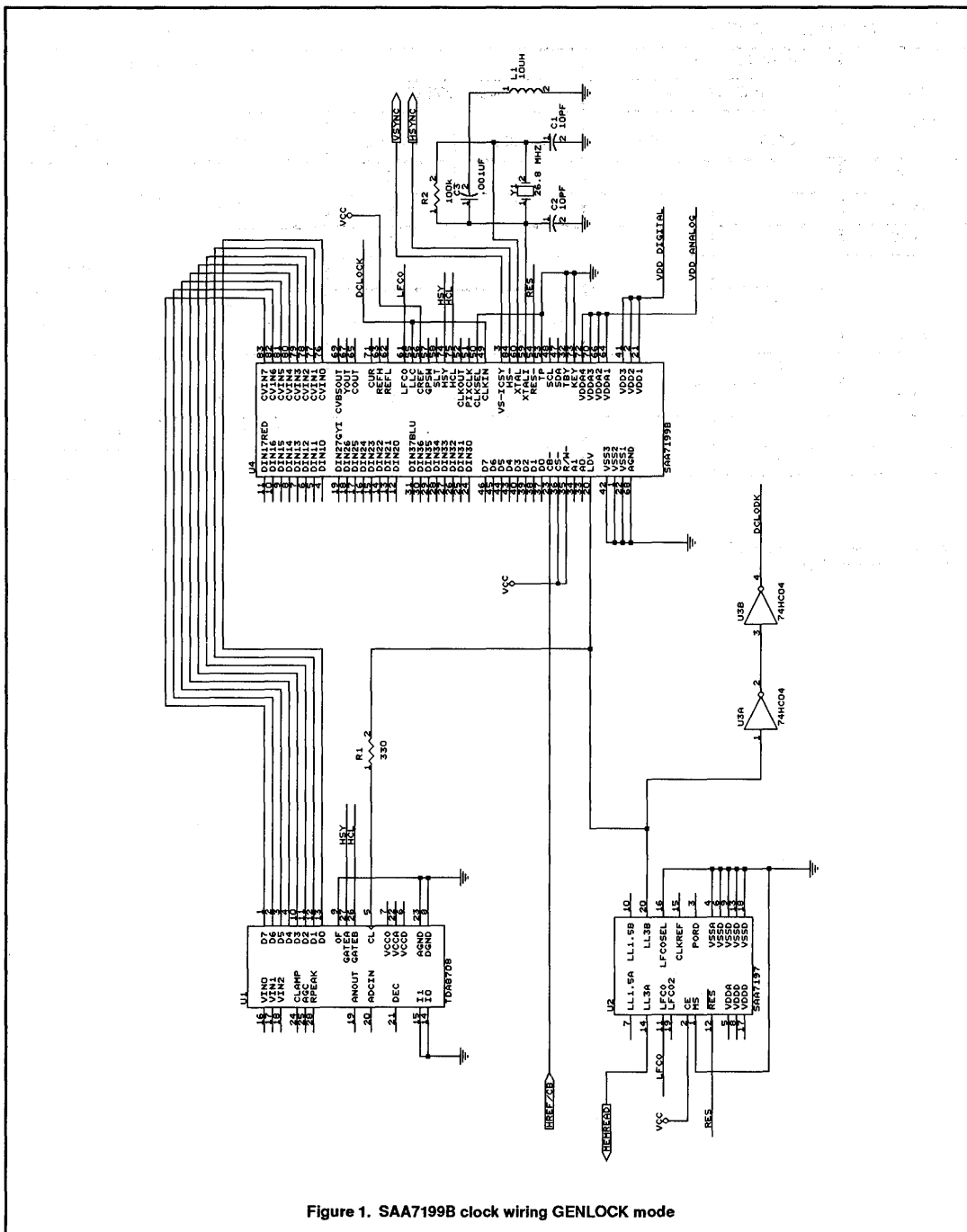

Figure 1. SAA7199B clock wiring GENLOCK mode



# SAA7199B operational modes

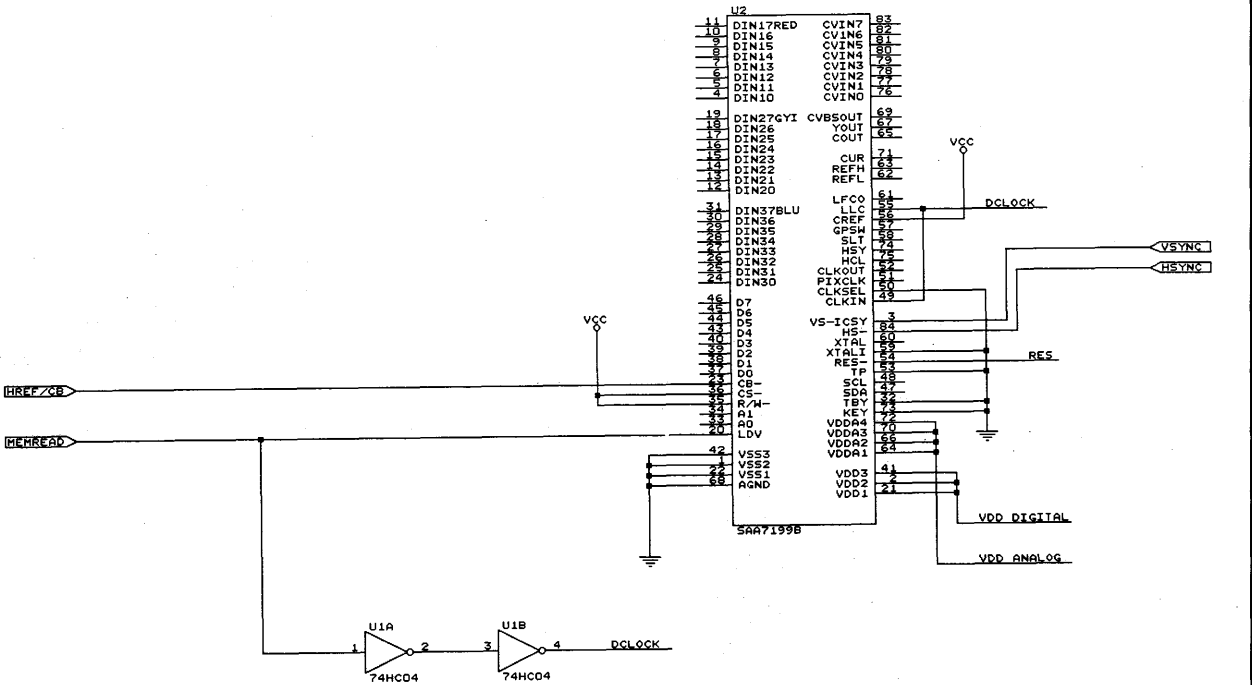

Figure 3. SAA7199B clock wiring Slave mode





# SAA7199B operational modes

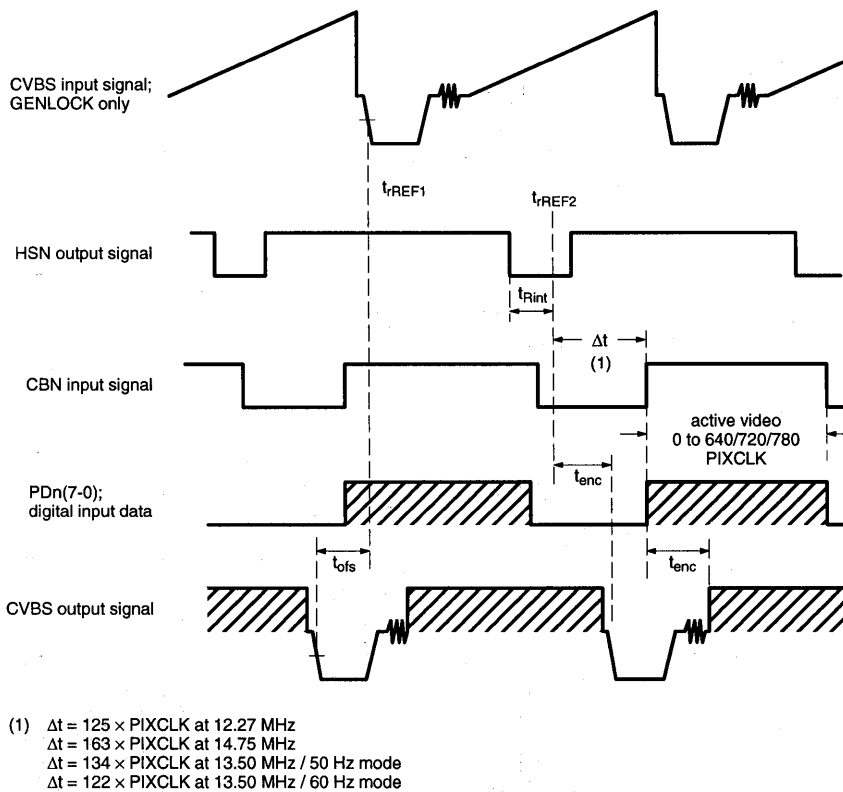

Figure 5. Processing delay and programmable timing

# Desktop video demo board

# DTV7194/96

Author: Leo Warmuth

## OVERVIEW

The DTV7194/96 demo board shows the system concept of Philips desktop video ICs. The main video processing functions incorporated in the demo board, are:

1. Video capture with multistandard decoding
2. Standardized digital video signal interface
3. Digital scaling
4. Frame buffer and related control
5. Video encoding
6. DACs and RGB conversion.

The DTV7194/96 demo board features the following Philips desktop video ICs:

TDA8708	8-bit ADC for CVBS and Y
TDA8709	8-bit ADC for CVBS and C
SAA7194/96	Digital true multistandard decoder—NTSC, PAL, and SECAM; horizontal and vertical scaling with filtering in both horizontal and vertical domains; control function for brightness, contrast, and saturation; expansion port I/O: SAA7196 also includes clock generator circuit
SAA7197	Clock generator; only needed in combination with SAA7194
SAA7199B	Digital NTSC/PAL encoder
SAA7169	Three channel ADC (RGB)
SAA7165	DAC for YUV 4:2:2 with peaking; color and transient improvement
TDA4686	High-speed YUV-RGB matrix with switch and control functions

The demo board also uses the following Philips ICs with general purpose functions:

PCF8574	I <sup>2</sup> C serial-to-parallel interface
PL22V10	Programmable Logic Device (PLD)
PLC42VA10	PLD
PML2552	PLD
87C054	Microcontroller (MTV), I <sup>2</sup> C controller, character overlay generator
PCF8582E	EEPROM with serial I <sup>2</sup> C interface
82B715	I <sup>2</sup> C booster

This document focuses on the functionality and interfaces of the new highly integrated video capture IC SAA7194/96, also called DESC:

- Digital multistandard decoder (NTSC, PAL, SECAM); SAA7196 includes also clock generator circuit.
- Expansion port with standardized digital video interface, CCIR oriented coding of digital YUV
- SCaling with programmable filter in horizontal and vertical direction for anti-aliasing and asynchronous FIFO buffer for easy memory interface.

In addition, a memory controller is described, realized by means of PLDs, which demonstrates both scaler output interface modes: synchronous (transparent) and asynchronous (FIFO) operation. The problem of conversion from interlaced to non-interlaced video signal and vice-versa is addressed, too.

The appendix shows all the schematics and listings of the PLD programming, i.e., logic equations and state machine definitions.

## FRONT END

The front end, with the analog-to-digital converters TDA8708 and TDA8709, includes automatic clamp and gain control. This circuitry is identical to the front end processing used for SAA7191 and SAA7151. For a more detailed description, please refer to the application note "DTV7199 Digital Television Demonstration System," p. 2-68. There is no significant functional difference between SAA7194 and SAA7196 beyond the clock generator circuit inside the SAA7196. The application circuitry described here is prepared for either one. The application, including the programming model for the decoder part of the SAA7194/96, is very similar to that of the SAA7191.

## THE PORTS OF THE SAA7194/96

### Adaptor

The layout of the DTV7194/96 demo board provides a ring of through-hole measurement points around the 120-lead quad flat pack (QFP) package. This layout enables the signals at each pin to be probed.

### Expansion Port

The expansion port of the SAA7194/96 is a bi-directional digital video signal interface with YUV and 4:2:2 sampling scheme. The signal format, i.e., the meaning of the code values, is based upon CCIR recommendation

601. The expansion port carries three types of signals:

- 16-bit wide YUV data
- synchronization signals, HREF and VS
- LLC and CREF clock signals.

These signals can be selected independently as input or output by means of the I<sup>2</sup>C bus. The direction pin DIR can switch the data stream on a pixel-by-pixel basis.

The expansion port taps the signal path between the decoder part and scaler part of the SAA7194/96. The expansion port interface, as output, looks exactly like the output of the SAA7191, and is compatible. As input, the expansion port feeds the scaler part of the SAA7194/96. As input, it can share its timing with the decoder part, or it can provide its own timing signals, including clock, even if it is asynchronous to the line locked clock of the decoder part. In the latter case, the decoder part, together with the analog front end (ADCs) and CGC, determines its clock and stays locked to the incoming analog CVBS or Y/C signal.

The signals of the expansion port are brought onto a separate connector called DAVE. The two I<sup>2</sup>C signals are also provided. The connector is prepared for a ribbon cable connection, input or output, and support interface to other video signal processing devices, e.g., for compression or decompression, video conference.

### Scaler output port

The scaler output of the SAA7194/96 has—depending on the chosen data format—up to 32 data lines in the VRO port. The SAA7194/96 provides various RGB, YUV, and gray-scale data formats at the VRO scaler output port. The circuitry of the DTV7194/96 demo board supports the two formats:

- RGB 24 bits in 4:4:4 sampling scheme
- YUV 16 bits in 4:2:2 sampling scheme, one pixel at a time.

The color key 'alpha-bit' is available and used in both formats. The demo board does not utilize the 2-pixels-per-longword formats, which are provided by the SAA7194/96 for wider memory organizations, which would enable very-high-speed read pixel rates at the display side.

The scaling output port of SAA7194/96 has two interface modes:

- the asynchronous FIFO mode
- the synchronous transparent mode.

The DTV7194/96 demo board works in both interface modes.

In the asynchronous FIFO buffer mode the SAA7194/96 operates with a FIFO 16 words

## Desktop video demo board

DTV7194/96

deep and up to 32 bits wide, and provides the signals:

- HFL, the 'half-full-flag', indicates that the device has at least 8 valid words in the output FIFO
- INCADR, the 'increment-address' signal, indicates—together with HFL—that the memory controller should increment line and/or field pointer

and requires the signals:

- VCLK, a gated clock burst, as answer to a request by HFL to empty the FIFO
- VOEN, output enable signal, whose use is optional.

The operation of the FIFO mode requires that the memory controller provide a gated VCLK after an HFL request to empty, or partly empty, the FIFO. It is recommended to apply a burst of 8 VCLK pulses. The SAA7194/96 has already "preloaded" the output with the "next-to-deliver" signal before it requests a burst of VCLK. Then, the first VCLK rising edge clocks out the next following sample. VCLK is the clock which directly writes into memory or a register immediately following the DESC output.

For the synchronous, transparent mode the SAA7194/96 requires a continuous clock VCLK, synchronous to its scaler input, and delivers output data qualified by various valid and gate signals:

- PXQ: qualifying the actual pixel as valid
- LNQ: telling that this line (will) carry valid data
- HRF: delay compensated HREF signal
- HGT: enveloping that part of line selected for scaling
- VGT: enveloping that part of field selected for scaling
- O/E: identifying odd and even field.

Not all these signals are needed at the same time, but their availability may simplify the design of a memory controller, or make a system more flexible and capable. For example, the presence of the false-state of the line qualifier LNQ or vertical gate VGT informs the system that there will be, for a certain time, no HFL request, and the system may undertake other access to the memory.

The demo board DTV7194/96 is made to demonstrate both scaler output interface modes. As all pins of the SAA7194/96 are available on test points, the behavior of the concerned control signals can easily be observed. The control logic for both cases is embedded in a single PLD implementation. For the PLD programming, refer to the listings in the appendix. Some aspects of the logic equations and state machine structure are explained in the following section.

## FRAME BUFFER

### Concept for Frame Buffer Controller

The concept for the memory control on the DTV7194/96 demo board is guided by the desire to:

- maximize the usage of given memory capacity
- ensure synchronous scaling and display sizing
- support interlace/non-interlace conversion
- minimize the effort on control logic.

The solution has the following main components:

#### Serial Stream with embedded "Marker"

The video scanning technique maps the three-dimensional video stream into a one-dimensional, serial signal stream. But some markers are inserted as dummy pixels (not to be displayed), to signal when a line, field, or frame is complete. This stream is written into memory in a strict serial one-dimensional manner.

The start-time of the read process is controlled by given display raster coordinates, and then data is read until an end-of-line marker is found in the data stream (or an end-of-field/frame marker). The read process pauses and resumes again at given display raster coordinates.

Independent of the actual input picture dimensions, the memory can get filled up to the last pixel. There is no waste by incompletely filled rows. A change of input picture dimensions, e.g., changing of scaling factor, is immediately transported to the read and display window control by the signal stream itself.

CCIR-601 reserves the codes 00 hex and FF hex for synchronization purposes. The SAA7194/96 ensures that the signal stream does not use these codes. The DTV7194/96 demo board uses the code 00 hex as end-of-line marker (eol) and the code FF hex as end-of-field (eof) marker.

#### Alpha "Marker"

In an extension to this eol/eof marker concept the alpha bit (color key signal) is also encoded into the data stream by means of a special marker-code. The luminance value of that pixel, which should be keyed-out, is overwritten with a code, to be interpreted as 'transparent', i.e., as a pixel not to be displayed. This approach makes the need for an additional alpha bit plane in the memory obsolete, reduces memory requirements, and enhances memory efficiency.

The SAA7194/96—in FIFO mode—fills up unused FIFO burst words with dummy pixels. The fill values are coded with 01hex. The DTV7194/96 demo board uses this code as transparent pixel, or key marker, too.

#### Two Field Buffer Banks (FBB)

The frame buffer memory is split into two banks, one for "odd" (upper) fields the other for "even" (lower) fields, respectively, "even" and "odd" lines. The address-pointer toggle from one bank to the other can be controlled independently for read and write processes. Conversion between interlace and non-interlace schemes can easily be performed.

If a video source is interlaced, the first (odd) field gets written into the "lower" FBB, the second (even) field gets written into the "upper" FBB (field toggling). Reading for an interlaced output (video display) accesses the memory in opposite order: during odd field the "upper" FBB gets read, during even field the "lower" FBB gets read. The time sequence is maintained and no tearing occurs where read- and write-address-pointer are crossing. Reading for a non-interlaced output will "de-interlace" the stored two-field picture by reading from both FBB in a line-alternating fashion (line toggling).

A non-interlaced source writes its first line, and all odd lines, into the "upper" FBB, and the interleaving even lines into the "lower" FBB (line toggling). Reading for a non-interlaced display will access the memory in identical order. Reading for an interlaced output will "interlace" the stored single frame into two fields by reading during the "odd" field from the "upper" FBB, and then during the "even" field from the "lower" FBB in a field-alternating fashion (field toggling).

#### Serial Memory: FRAMs

Because the video data stream in this application is exclusively serial, FIFO-DRAM ICs are utilized for the frame buffer circuitry. These FRAMs don't need any addressing (which saves external address generation) and therefore significantly simplifies the control logic. But VRAMs or standard DRAM memory applications could also be used and would benefit by the "marker" control concept and two field buffer bank approach.

#### Byte Serial, Field Serial

Most of the commonly available memory ICs have an address space which is deeper than the number of pixels in a standard video field. The used FRAMs, for example, have 262144 storage locations. A regular NTSC field with 240 lines and 640 SQ-pixels per line results into 158600 pixels total, which is about 58% of the available memory address range.

An effective way to get higher memory utilization is to place the information

# Desktop video demo board

DTV7194/96

belonging to one pixel into two memory addresses. The 16-bit wide YUV format could be converted into two consecutive bytes (byte-serialized), like a D1 or CCIR-656 data stream. This approach would require memory with double the speed.

A similar saving of memory devices can be achieved by writing the two fields of an interlaced source into a single FBB, one after the other. They can be read again for interlaced display in the same sequence. This approach is supported as an option by the DTV7194/96 demo board.

It is obvious that then only 85% of a regular NTSC-SQP field or frame will fit into the given memory space. But this conflict can be resolved either by "cropping" only the interesting area of the field, i.e., throwing peripheral information away, or by "squeezing" the picture content into fewer pixels, i.e., scaling somewhat down. Both methods can be combined and are supported by the scaling function of the SAA7194/96. Programming of source size determines the cropping function. Destination size, relative to source size, determines the scaling factor. Both source and destination size can be defined independently in horizontal and vertical dimensions.

The memory control function of the DTV7194/96 demo board is capable of demonstrating various methods of optimal memory usage and minimum control effort for different application requirements. Because the demo board combines various approaches in the same hardware, the circuitry itself may show a certain amount of overhead. The various algorithms are selectable via I<sup>2</sup>C programming. As the logic is embedded in PLDs, the circuitry offers a multitude of options (by re-programming the PLDs).

The following description will focus on the core functionality.

## Functional Description and Partitioning

### Frame Buffer

The frame buffer memory block consists of 12 FRAM ICs. The 24-bit RGB format with interlaced signal requires that capacity. A straight 16-bit wide YUV frame buffer requires only 8 FRAMs. With some restrictions in available picture size, a set of only 4 FRAMs is needed. To support only smaller picture sizes, e.g., CIF-format, the application requires just 2 FRAM ICs.

### Write Interface

The schematic sheet WRITE.SCH shows the interface between the SAA7194/96 scaler

output port VRO and the frame buffer. The PLD PLC42VA12 named WSYNCB works as clock divider, clock driver, and timing circuit, and takes care of the interface logic to serve the FIFO output mode of the SAA7194/96. But it can also be switched to operate for transparent mode.

For the FIFO mode, the input signals HFL and INCADR are used, and a burst of 8 VCLK cycles is provided. For the transparent mode, the input signals PXQ, HRF, and SVS are used. In both operation modes a unified set of control signals is sent to the second PLD. These control signals are closely related to the chosen frame buffer control circuit. The signals are:

- GATE gate signal = valid data at VRO-port
- EOL end-of-line flag, to insert an end-of-line marker
- EOF end-of-field flag, to insert an end-of-field marker. If both flags (EOL and EOF) occur together, an end-of-frame is signaled to reset the write address pointer
- FBBID field buffer bank ID, to control into which frame buffer bank the actual data needs to be written.

The second PLD PML2552, which is named WPATH, is used mainly as a huge data bus multiplexer. The data streams for YUV format and RGB format are mapped into the frame buffer in such a way that its output busses can be used directly by the SAA7199, which can accept YUV as well as RGB formats. A third data bus is provided for the Red-signal, necessary for the 24-bit RGB format.

WPATH further inserts the marker codes for EOL, EOF, and ALPHA into the data stream. It also generates the delay adjusted write enable (WE1 and WE2) and write pointer reset (RSTR) signals for the frame buffer.

For the details of the PLD programming, refer to the listings in the appendix. The various operation modes of the write control logic are programmable via I<sup>2</sup>C, and the serial-to-parallel converter IC PCF8574 at position U20 with I<sup>2</sup>C device slave address 42 hex.

### Read Interface, Window

The schematic sheet WINDOW.SCH shows the read control logic. By means of two 8-bit words the horizontal and vertical start points of display window are defined, and present the scaled picture. If the display timing is synchronized to the expansion port, this signal can be chosen as background signal. In case the display (output) timing is determined by the SAA7199 digital encoder in master mode operation, then an artificial color bar test pattern is used as background signal. The combined signal is fed to the digital encoder and to two DACs for

YUV-conversion (SAA7165) and RGB-conversion (SAA7186), and is also brought to a connector (JP7). It can also be multiplexed via this connector with an external signal by means of the MUTE control signal.

The PL22V10 PLD, named READCLK, is mainly the function of a signal source selector and clock driver. The two PML2552 PLDs share the task to define the horizontal and vertical position (start point) of the window. READV performs a vertical counter, counting in half lines. The vertical window offset is defined by VOS[8..1] via PCF8574 at position U34 with I<sup>2</sup>C device slave address 40 hex. The vertical starting trigger is sent from READV to READH in the form of the auxiliary signal FS-GO. FS-GO is a kind of delayed field-ID signal, changing its state in that line where the window should start.

READH performs a horizontal pixel count. The horizontal window offset is defined by HOS[8..1] via PCF8574 at position U35 with I<sup>2</sup>C device slave address 41 hex. When both horizontal and vertical enabling signals are true, READH will start reading from the frame buffer. The incoming data stream is checked for the relevant marker codes. If an end-of-line or end-of-field is detected, the read process is stopped until the next horizontal or vertical enabling signal, respectively. As the FS-GO signal carries the odd/even field ID, READHB can decide from which field buffer bank to read (RE1 or RE2).

The horizontal counter is also used to generate the auxiliary signal HS2RD, to be sent to READV. HS2RD is a half-line indication signal, staying LOW for the first half line, and then HIGH for the second half line. This enables READV to count vertically in half lines. Comparing the vertical sync edges of VSD with the state of HS2RD defines the output ID, i.e., display field ID, and when to reset the read address pointer. The vertical counter in READV is also used to generate a luminance and color test pattern as background signal. Further, the video overlay control signals from the MTV microcontroller can be used to add foreground signals.

For the details of the PLD programming, refer to the listings in the appendix. The different operation modes of the read control logic are selectable via I<sup>2</sup>C and the serial-to-parallel converter IC PCF8574 at position U40 with I<sup>2</sup>C device slave address 43 hex.

### Implementation, control logic

The listings of the programs of the PLDs as given in the appendix contain extensive comments to improve the understanding of the logic equations and statements. A few

## Desktop video demo board

DTV7194/96

explanations regarding the construction of the state machines are given in this section.

### WSYNC

The main state machine in WSYNC handles the interface with the scaler output of the SAA7194/96 in FIFO mode. The IDLE state is the state after regular VCLK-burst transmission, waiting for further HFL, or an INCADR=Low stimuli, to enter the INCHOT state. INCHOT has two exits.

Combining INCADR-low with HFL-high signals the end of a line and generates an EOL-flag. But the LINEND state cannot return to IDLE, otherwise it would be re-triggered by a second line-increment pulse combination, and issue a second EOL. The memory read control side would be mis-triggered by this. Therefore, the LINEND state is extended by LWAIT, and can toggle between these two states without action, in order to be insensitive in the case of a second line-increment pulse sequence. A regular HFL during LWAIT starts the normal VCLK bursts.

The second exit of INCHOT is the return to neutral HFL-INCADR combination, which signals the vertical end of processing, and issues an EOF-flag. In this VERTEND state a line-increment condition may occur to signal the begin of an odd field. Then EOL-EOF double flag is issued to indicate Field ID reset and Frame Buffer Bank pointer reset.

The state machine for the transparent mode is somewhat simpler. It is built to generate the same EOL and EOF flags.

### WPATH

WPATH is mainly a data bus multiplexer. The control signals need to be registered to be synchronous to data. WPATH sorts out the FIFO fill pixels, inserts the alpha marker and EOL and EOF markers. The reset of the write address pointer is delayed another clock cycle to avoid conflict with a last write of EOF.

### READCLK

In this programming, READCLK is used mainly for clock selection and as clock driver. It also routes the horizontal and vertical sync signals depending on who the timing master is.

### READV

The main function of READV is the vertical counter, which is re-triggered every field by VSENC, the phase of vertical sync relative to the halfline signal HS2RD determines whether the following field is treated as an odd or even field. The equal comparison with VOS resets the read address pointer with RSTR. The following state, VWB1, represents the vertical window start for READH, by providing FSGO.

The vertical states distinguish an idle range above and below the line, where the window start is defined. (This may be used to issue different background signals, which is not implemented here).

READV also generates VSL, a 10-line long vertical blanking signal to support the generation on the sandcastle pulse sequence for the TDA4686.

### READH

READH has an horizontal counter. It starts the programmable (HOS) horizontal window and also generates the half line reference signal HS2RD. The horizontal state machine is triggered by the window start condition and the end-of-line and/or end-of-field marker in the data stream. The state machine has to work around the signal delays between enabling a read cycle at the FRAMs, and placing valid data on the output bus. In the FIRST state, the marker decoding logic will not see valid data, but the trisate signal of the FRAMs. In the LAST1 (and WBLK1) state, the reading from the FRAMs has already stopped, but there may be the next marker in the signal path pipe line. If this pixel was not a marker, it was a real pixel, i.e., the first pixel of the next line. This pixel is lost for display.

### DIGITAL ENCODER SAA7199B

The backend circuitry with the digital NTSC and PAL encoder is identical to the backend processing of the DTV7199 demo board. For a detailed description please refer to the application note "DTV7199 Digital Television Demonstration System," p. 2-72.

### VIDEO DACS AND MATRIX

For conversion of the digital YUV data stream to analog RGB, the SAA7165 video DAC is used to convert the data stream to analog YUV, and the TDA4686 RGB matrix combination IC is used to convert the analog YUV into analog RGB with control over brightness, saturation, and contrast.

The SAA7165 (VEDA2) filters and demultiplexes the UV data and positions this chroma data with respect to the proper luminance sample and performs the D to A conversion. In addition, software controlled aperture correction and color transient improvement of the video may be performed to enhance picture quality.

The TDA4686 receives this analog YUV signal, reclaims it and converts it to RGB via an analog matrix. Two additional RGB signals may be switched into this path, assuming that they are congruent to the main

RGB information (that is, they are synchronous). Brightness, saturation, and contrast control may be affected via the I<sup>2</sup>C bus. Also, peak white and color balance may be controlled via I<sup>2</sup>C.

The TDA4686 uses a multi-level pulse to control certain blanking and timing parameters, called a sandcastle pulse. Because this pulse is generally derived from the sync signals, it is necessary to account for the 44 clock pipeline delay introduced by the SAA7165 when generating this pulse so that the pulse has the proper positional relation with the output video from the SAA7165. This is achieved by the PLD "castl".

Additional circuitry at the output is used to produce proper DC and drive levels to drive 75Ω loads.

A more detailed description of this analog backend module is given in the application note titled "Digital Video Evaluation Board" (also in this chapter, p. 2-171), along with register programming for these two devices.

### INTERLACED VIDEO SIGNALS

The broadcast television standards—and the related camera standards—are all interlaced. There are two fields (field rate 50Hz or 60Hz), whose scan lines are interleaved to each other. The second field scans its lines right in between the lines of the first field, but a moment—i.e., a period of the field rate—later. Both fields together form a frame. The line-to-field scan interlacing method was developed to balance achievable vertical resolution with motion resolution and required transmission bandwidth. For mainly static pictures and scenes, a high vertical resolution can be achieved by counting the information of two fields as one frame. For high motion video pictures, a time resolution of 50Hz or 60Hz is achieved, which is superior to the 24Hz of cinema film.

If both input and output of the frame buffer memory is structured in an interlaced manner, the situation is rather obvious. This is the case if the SAA7194/96 decodes a standard television signal and the SAA7199 encodes a standard television signal. We have to take care that the lines of the second field get displayed inbetween the two lines of the first field, as they were scanned in the first place. In a straightforward way, the two fields are written into two memory banks, and also read from them in the right sequence and phase (i.e., starting the line counting).

In the case that input and output field rates are not identical, two memory banks are clearly insufficient to ensure that field two is always and only read after the correlated

## Desktop video demo board

DTV7194/96

preceding field one. An incorrect field sequence would generate motion disrupting artifacts (jumping back and forth).

If the vertical scan speed, i.e., time from line to line, is not the same at the write and read side of the memory, so called "tearing" can occur. This is the case if the signal source is generated by scaling, for example. The write and read pointers in the memory address space are crossing each other. The results are that information displayed as one field are originated by separate fields.

To avoid these two artifacts, memory with a capacity to store four fields and dedicated control would be necessary. The DTV7194/96 demo board, however, solves this problem with only two memory banks (field stores) by exchanging odd and even fields. If input and output are synchronous in vertical, it is ensured that reading and writing happens on different field buffer banks, and do never cross. For 1:1 mapping (i.e., no scaling) the output picture appears one line lower than the original.

If the input of the frame buffer memory is non-interlaced material, and the output of the memory needs to be interlaced, e.g., for the DENC, then "re-interlacing" has to take place. Non-interlaced video can get fed in via the expansion port from video decompression or artificial sources (graphics generation), or the scaling function itself can generate it by

programming it to one-field-only operation (odd field only, even field only).

"Re-interlacing" can be achieved by proper modification either of the write or read control of the frame buffer. The alternating lines of a non-interlaced field can be written in a line-toggling fashion into both memory banks, but read in a field toggling manner. This kind of re-interlacing is comparable—also comparable in results—to film-to-TV conversion.

If the input of the frame buffer memory is interlaced material, and the output of the memory needs to be non-interlaced, then "de-interlacing" has to take place. Non-interlaced frame buffer output may be required for display on a computer monitor, or to drive a video printer, or to feed a compression engine. De-interlacing can be achieved by proper modification either of the write or read control of the frame buffer. The alternating fields of an interlaced frame can be written in a field-toggling fashion into both memory banks, but read in a line toggling manner. De-interlacing in that way works well for static pictures, but creates artifacts during motion. DTV7194/96 has no provisions, regarding memory control, against these artifacts. The more preferable approach is to select the one-field-only operation for the scaling function in the SAA7194/96.

If both the input and output of the frame buffer are non-interlaced data streams, the

situation is transparent; one field is the same as one frame. The field toggling write mode would just write into one memory bank, depending on actual phase of vertical to horizontal sync. The read control has no chance—by any means—to know from where to read. Therefore, for this case, a line toggling mode on both sides is appropriate. This approach also allows storage of larger frames, e.g., 800 pixels by 600 lines, with the given board architecture, as it splits a frame into two 'interlaced' memory banks. But the demo board is not made to clock with real VGA clock rates.

The FBB pointing sequence as part of the memory control can "field-toggle" or "line-toggle" between the two memory banks. This toggle mode is selectable via I<sup>2</sup>C, both for writing and reading, and independently of each other. By that, interlaced and non-interlaced video signals can be handled and converted into each other.

### SUMMARY

Many other data output formats and memory architectures are possible using the SAA7194/96 and associated chips. This application note touches on just a subset of possibilities to suggest an approach that uses minimum memory and memory control devices to implement a system.

Desktop video demo board

DTV7194/96

APPENDIX  
Schematics of DTV7194/96 demo board

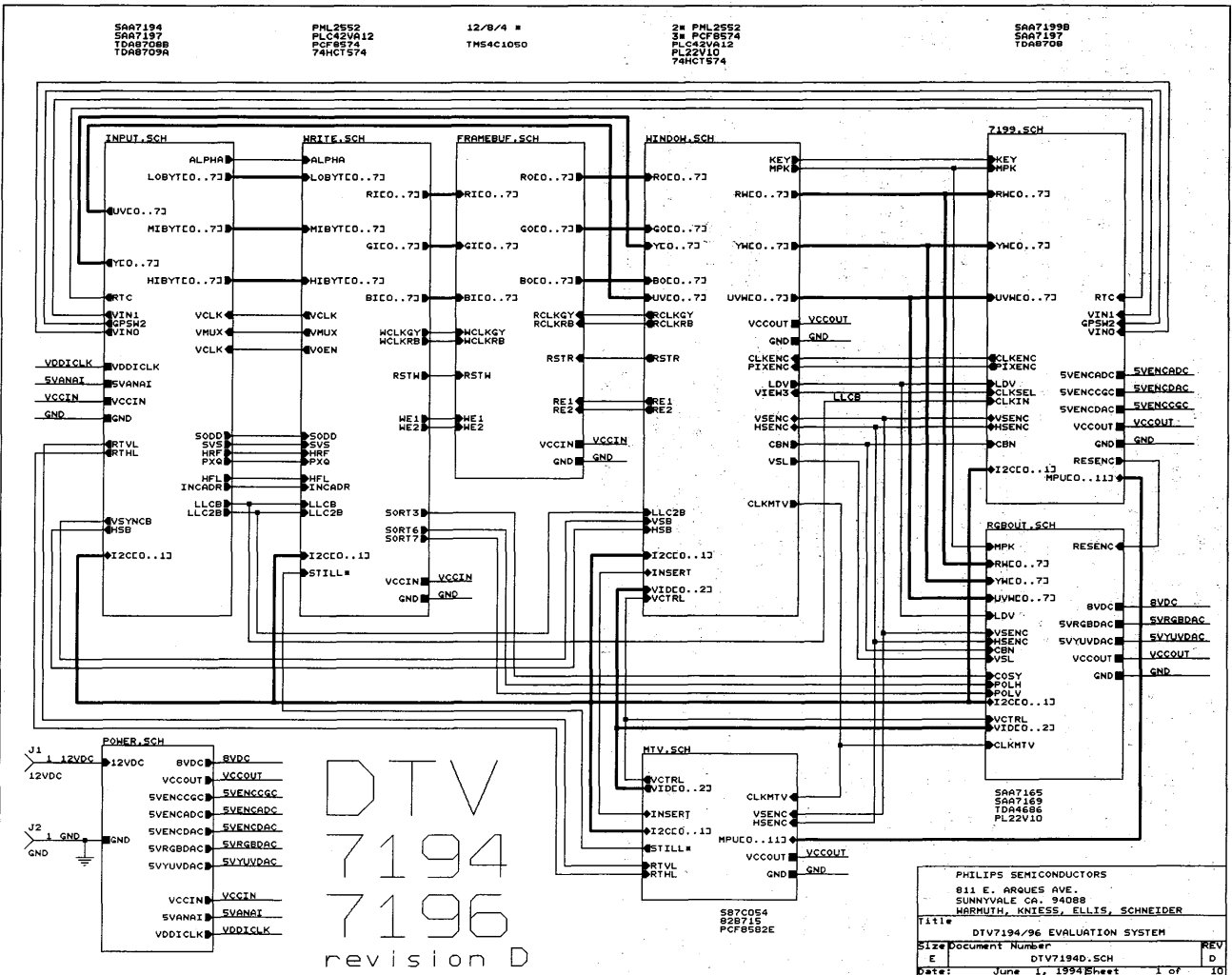



Desktop video demo board

DTV7194/96

# POWER SUPPLY

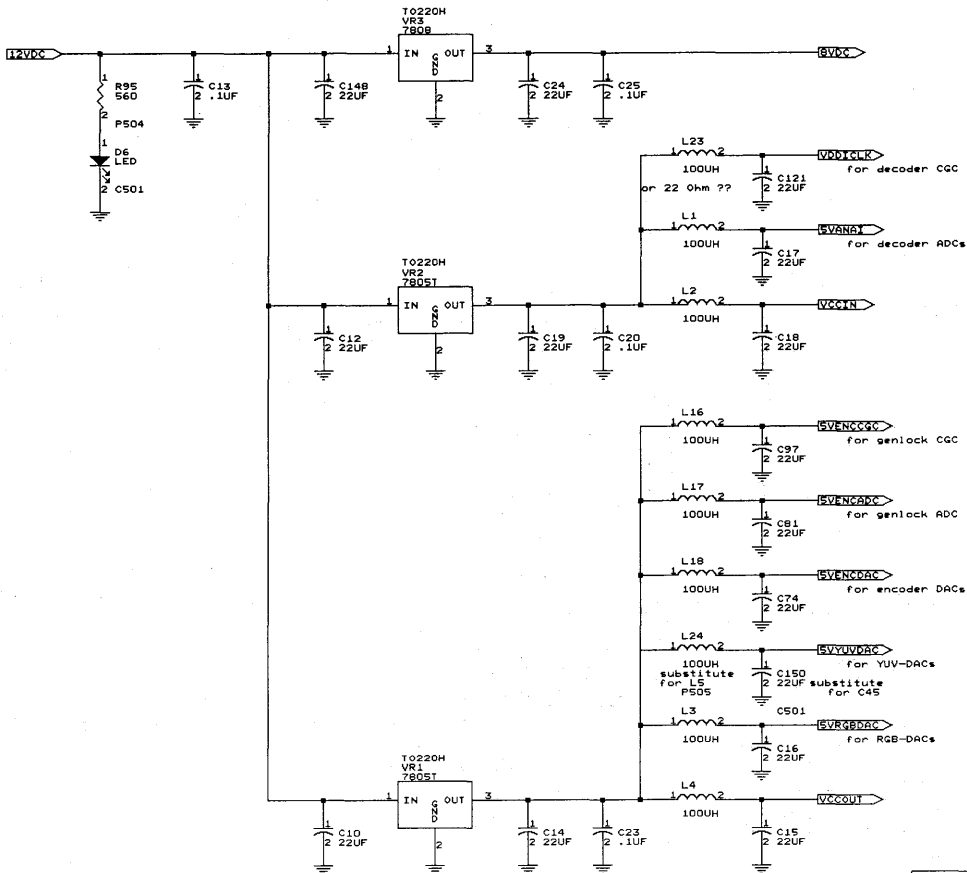

PHILIPS SEMICONDUCTORS		
Title DTV7194: POWER SUPPLY, DECOUPLING		
Size	Document Number	REV
E	DTV7194D : POWER.SCH	D
Date:	December 2, 1993	Sheet 5 of 10

Desktop video demo board

DTV7194/96

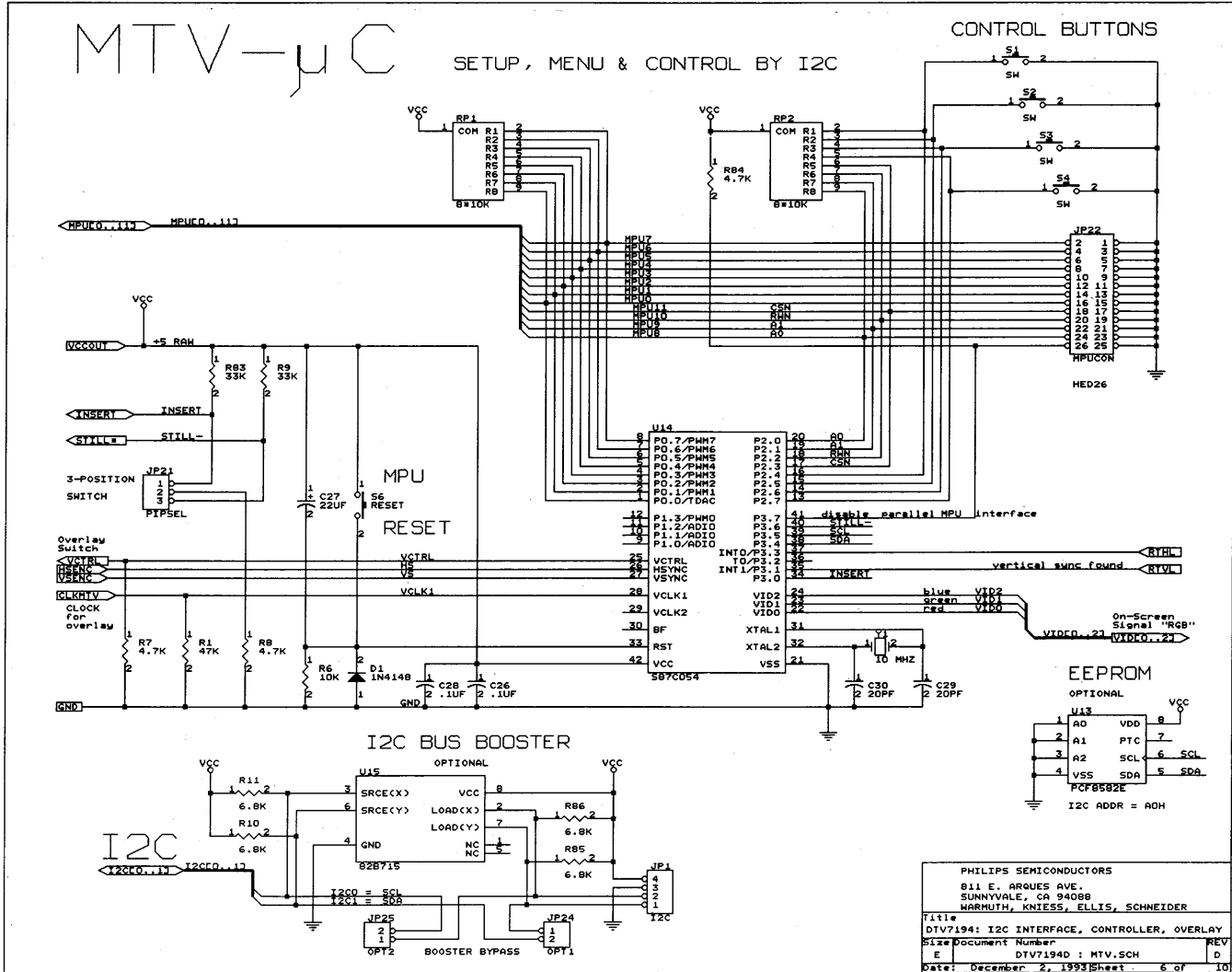

Desktop video demo board

DTV7194/96

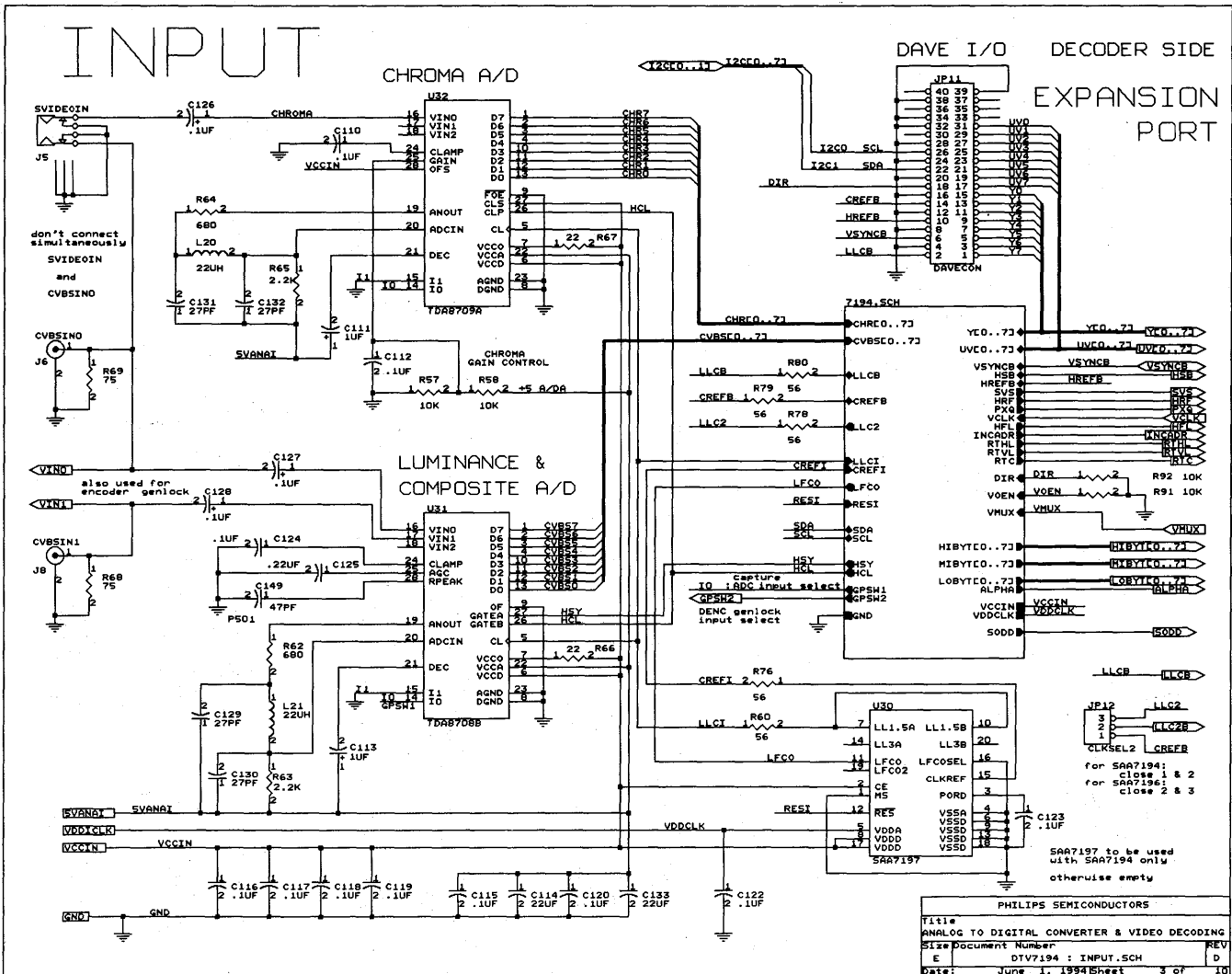

Desktop video demo board

DTV7194/96

SAA7194/96 and pin access

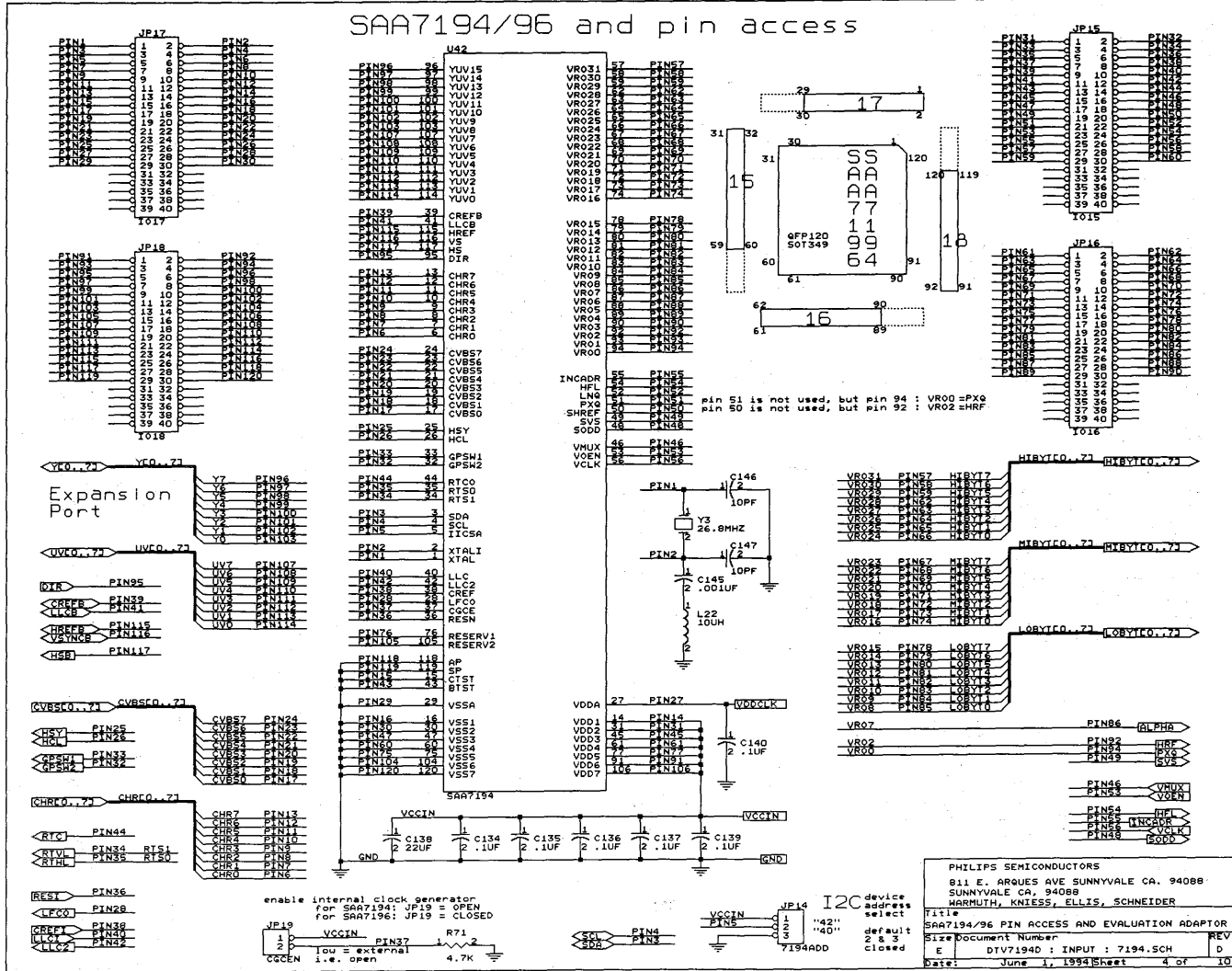



Desktop video demo board

DTV7194/96

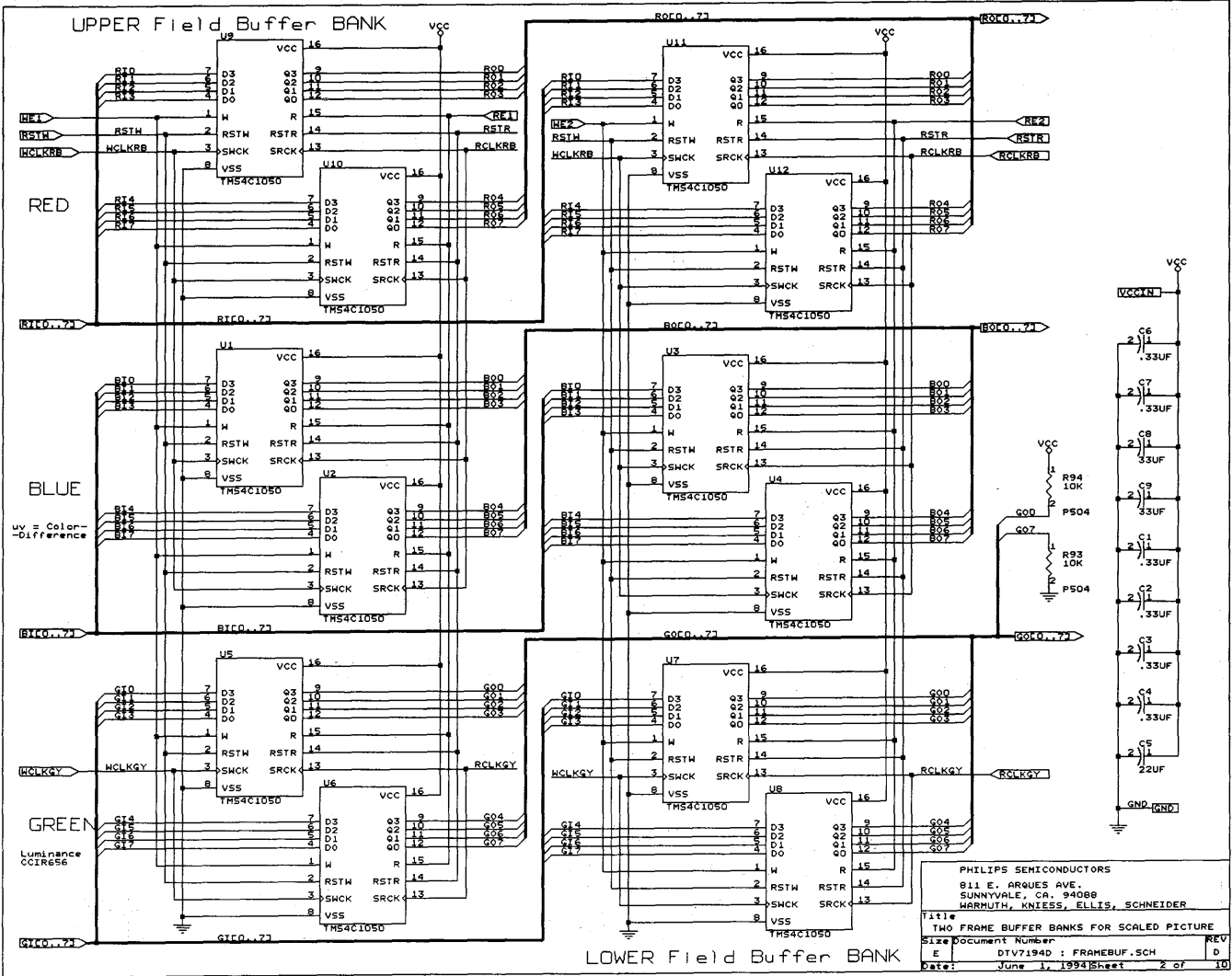

PHILIPS SEMICONDUCTORS  
 911 E. ARQUES AVE.  
 SUNNYVALE, CA. 94088  
 HARMUTH, KNISS, ELLIS, SCHNEIDER

Title: TWO FRAME BUFFER BANKS FOR SCALED PICTURE  
 Size: Document Number: REV  
 E DTV7194D : FRAMEBUF.SCH D  
 Date: June 1, 1994 Sheet 2 of 10



Desktop video demo board

DTV7194/96

# NTSC/PAL ENCODER

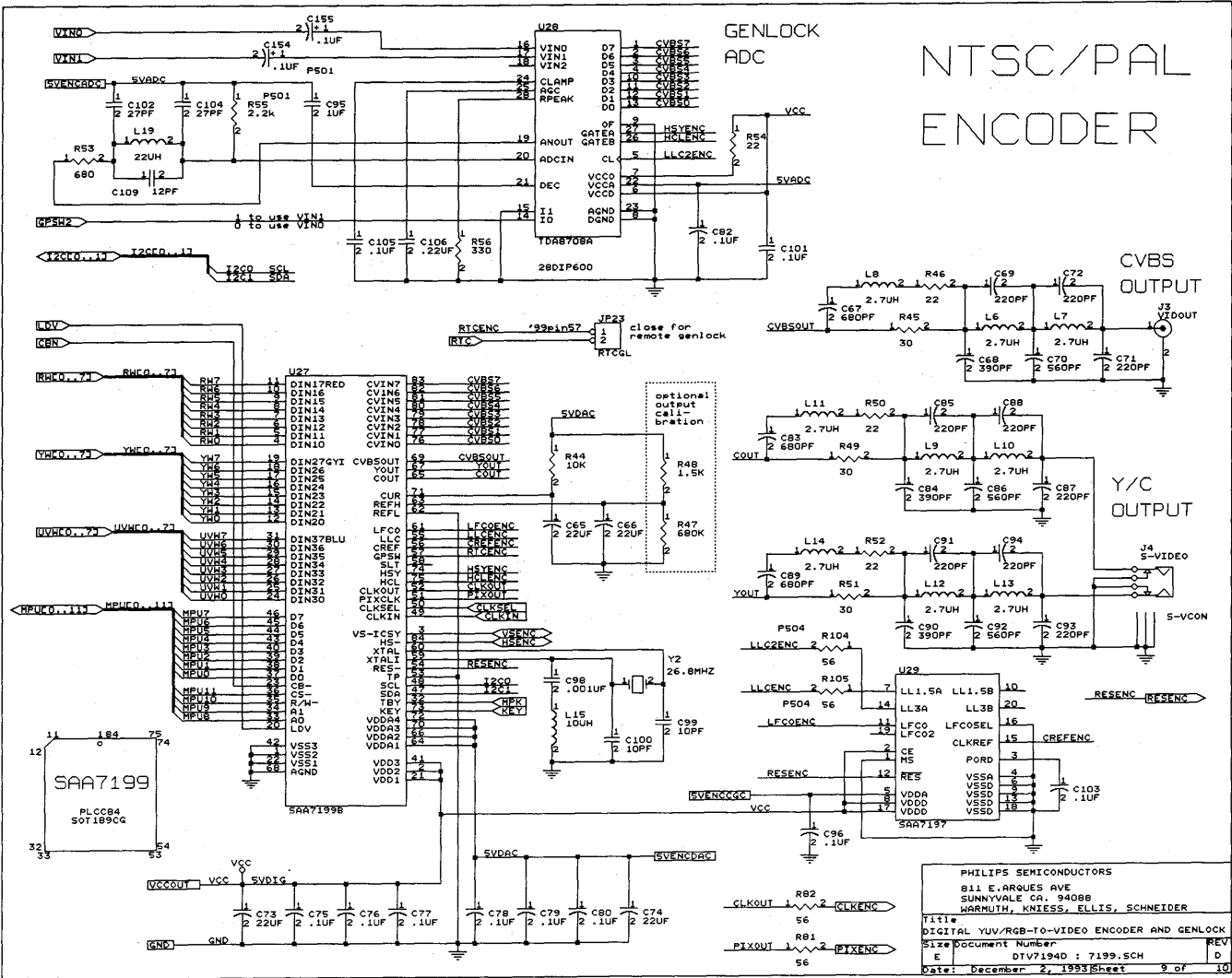



Desktop video demo board

DTV7194/96

# RGB-out

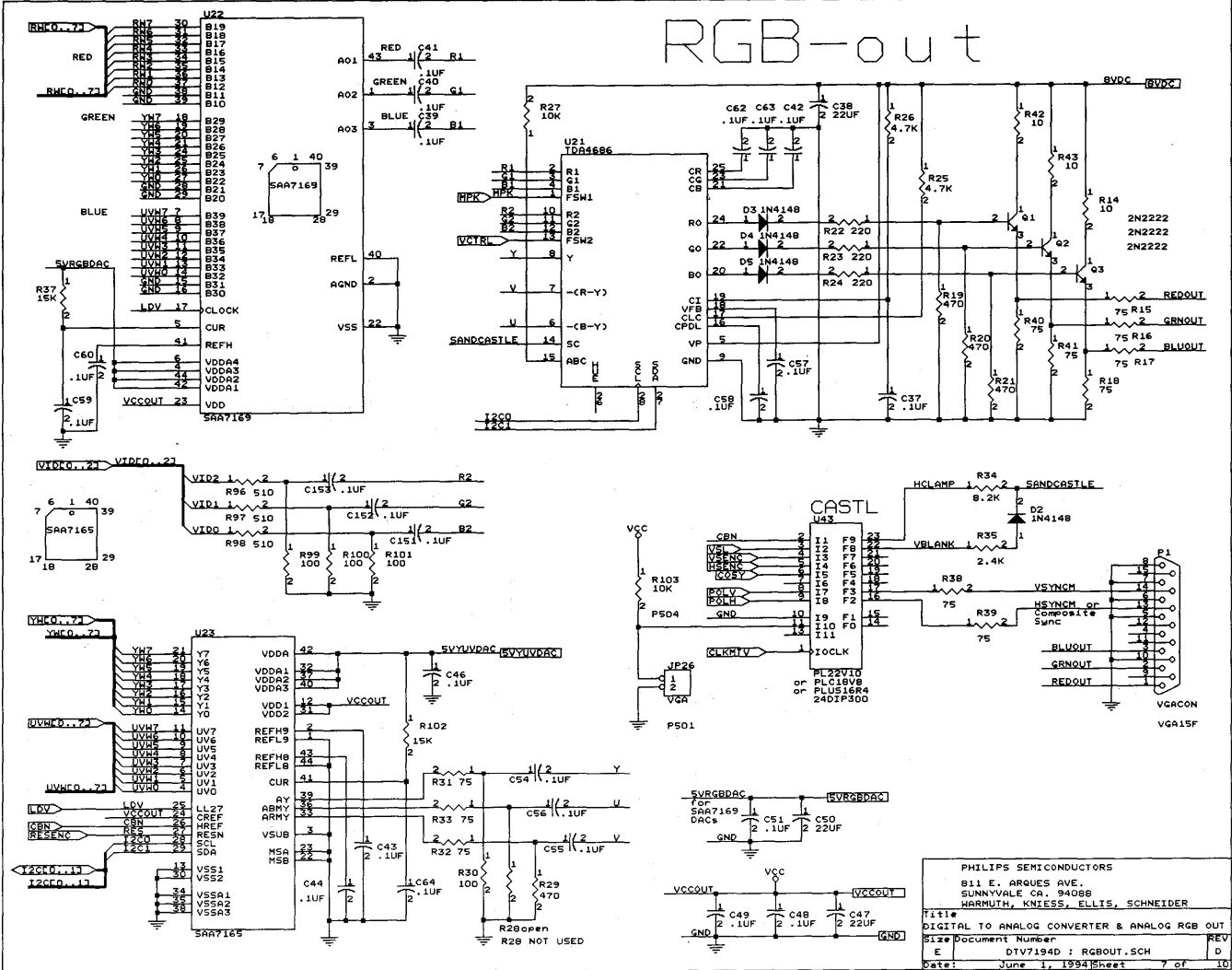

PHILIPS SEMICONDUCTORS  
 811 E. ARQUES AVE.  
 SUNNYVALE CA. 94088  
 HARMUTH, KNISS, ELLIS, SCHNEIDER

11114 DIGITAL TO ANALOG CONVERTER & ANALOG RGB OUT  
 5127 Document Number DTV7194D : RGBOUT.SCH REV D  
 Date: June 1, 1994 Sheet 7 of 10

May 16, 1993

2-117

## Desktop video demo board

DTV7194/96

## Programs of the PLDs used on DTV7194/96 board

WSD.EQN

```

" WSD      :      WriteSync & Clock :      clock drivers "
" ===== HFL,INCADR --> VCLK, EOL, EOF for "
" PLC42VA12 asynchronous FIFO mode "
"          PXQ, HRF, SVS --> EOL, EOF for "
" U16      synchronous TRANSPARENT mode "

```

CONTROL PARAMETER / SORT-bits

```

=====
SORT7 SORT6 SORT5 SORT4          under IIC address 42 hex
                                     =====
#7:  POLV, here not used
#6:  POLH, here not used
#5:  FIFOMODE :HFL and INCADR are the only (external) inputs
      to the fifomode state machine
      else: TRANSPARENT MODE: under trigger of SVS, HRF and PXQ
#4:  INTRL: interlaced/non-interlaced field mode
      only relevant if VRO is in transparent mode
      INTRL=1: FBBID is 'field toggling'
                issue RSTW before writing in even fields only,
                (reset frame buffer write address pointer)
                i.e. at the transition from odd to even field
                i.e. if vertend is not 'disturbed' by 'linc'
                RSTW is coded as 'eol & eof', or 'new-frame'
      else: non-interlace: FBBID is line toggling
                RSTW at the beginning of every field

```

NOMENCLATURE:

```

=====
FBBID : field buffer bank ID:  1 : _upper_  field buffer bank
                               0 : _lower_  field buffer bank

```

The lines of the upper field buffer bank are 'on screen' above the corresponding lines of the lower bank.

DESC / scaler generates  
 data for the \_upper\_ bank during the \_even\_ (2nd) field,  
 data for the \_lower\_ bank during the \_odd\_ (1st) field.  
 (--> extra line increment pulse at begin of odd field)

READ out of memory and line counting at the output / display  
 side is performed in such a way, that  
 during \_odd\_ field the \_upper\_ frame buffer bank is read,  
 during \_even\_ field the \_lower\_ frame buffer bank is read,  
 i.e. : the input odd field gets displayed as output even field,  
 the input even field gets displayed as output odd field.  
 Result: The FrameBuffer represents a one-field pipeline delay.  
 Benefit: No tearing at memory pointer cross-over.

```

@PINLIST " pin#:      to go into PLC42VA12 "
CLOCKIN I ; " 1: LLC2 or LLCB from expansion port "
VCLK  0 ; "18: clock at VRO-port, DESC-scaler output "
CLOCK  B ; "17: CLKAB at VRO-port-to-PML interface, PML-side "
CLKE  0 ; "16: clock at memory write interface, Y-G-channel "
CLKF  0 ; "15: clock at memory write interface, RB-channel "
      " second clock driver for FRAM memory bank "
HFL   I ; " 5: fifo half full flag "
INCADR I ; " 6: increment address, for line and field end "
PXQ   I ; " 4: pixel qualifier in transparent data stream "
HRF   I ; " 3: horizontal reference signal "
      " in transparent-data-stream "
SVS   I ; " 2: vertical sync, referring to scaler output "

```

## Desktop video demo board

DTV7194/96

```

GATE    O ; "20: valid pixel at VRO = in front of WPATHPMB "
EOLPIN  O ; "21: end of line flag, to WPATHPML "
EOFPIN  O ; "22: end of field flag, to WPATHPML "
        " both EOL & EOF together:
        " reset of FBBID write pointer for odd=1.field "
FBBID   O ; "23: Frame Buffer Bank ID: where to write to
        FBBIB = 1, i.e. 'odd field' into bank 1
        FBBIB = 0, i.e. 'even field' into bank 2
        " for re-interlacing of a non-interlaced source,
        write in line-toggling manner into both banks,
        if there are two banks (sort5 = 0)
VMUX    O ; "19: VMUX control for SAA7194/96 fifomode to 16 bit
        here used as RSTW monitor pin
VCLKGATE B; "14: reserved, to 'time-adjust' VCLK burst-gate "
        " can not used externally "

"
        SORTx under I2C bus address 44 hex
SORT4   I ; " 7: Source Field Mode:  1 : Interlaced
        0 : non-interlaced
SORT5   I ; " 8: Scaler Output Interface Mode, VRO operation
        1 : FIFO-mode
        0 : transparent-mode

@GROUPS
@TRUTHTABLE

@LOGIC EQUATIONS

        " === MODES OF OPERATION === "
FIFOMODE = SORT5 * SORT4 ; " Scaler Output Interface Mode "
INTRL    = /SORT5        ; " interlace / non-interlace "
FINT     = /SORT5 * /SORT4 ; " forced interlaced, FID-toggle"

        " === CLOCKS === "
INTCLK   = CLOCKIN ; " intermediate internal clock "
CLOCK.OE = 1 ;
CLKE .OE = 1 ;
CLKF .OE = 1 ;
CLOCK    = INTCLK ; " pixel clock at VRO & WPATH-in "
CLKE     = INTCLK ; " pix-clk for WPATH-out & FRAM "
CLKF     = INTCLK ; " just a second driver for FRAMs"

        " === CONTROL === "
VCLKGATE = /FIFOMODE " continuous clock "
        + FIFOMODE * Q3 ; " OR burst of clocks "
VCLKGATE.OE = 1 ; " to 'adjust' timing "
VCLK      = INTCLK * VCLKGATE ; " clock for VRO "
        " valid FIFO data at VRO "
GATE      = FIFOMODE * Q3 * (Q2 + Q1 + Q0) " count1 .. "
        + FIFOMODE * /Q3 * Q2 * /Q1 * /Q0 " .. count8 "
        + /FIFOMODE * PXQ ; " valid PXQ data at VRO "
EOLPIN    = EOL ;
EOFPIN    = EOF ;

        " VMUX = 0 ; " reserved "
test      = eol * eof ; " for monitor purpose only "
rstwtest .d = test ; " for simulation only "
rstwtest .clk = CLOCK ; " for simulation only "
vmux      = test * /rstwtest ; " leading edge "

        " === REGISTERS === "
Q[0..3].CLK = CLOCK ;
Q[0..3].RST = 1 ; " state machine register "
Q[0..3].SET = 1 ;

```

## Desktop video demo board

DTV7194/96

```

FBBID .CLK = CLOCK ;           " Frame Buffer Bank ID, "
FBBID .J = FBBIDJ ;           "       where to write to "
FBBID .K = FBBIDK ;
FBBID .SET = 1 ;
FBBID .RST = 1 ;
FID = FBBID ;                 " if there is interlaced source "

EOL .CLK = CLOCK ;
EOL .SET = 1 ;
EOL .RST = 1 ;

EOF .CLK = CLOCK ;
EOF .SET = 1 ;
EOF .RST = 1 ;

@INPUT VECTORS
"=====
[ FIFOMODE, INCADR,HFL, EOL,EOF, SVS,HRF,PXQ, INTRL,FINT,FID ]
" for ___FIFO___ mode "
NEUTRAL = 1 10 -- --- --- B ; " default input, no action "
HFULL = 1 11 -- --- --- B ; " regular HFL, start burst "
INCL0 = 1 00 -- --- --- B ; " incadr-up --> field incr."
LINC = 1 01 -- --- --- B ; " hfl-up --> line incr. "

" for ___TRANSPARENT___ mode"
PX = 0 -- -- --1 --- B ; " valid pixel, set LA "
HREFI = 0 -- -- 01- 10- B ; " horizontal reference "
HREFFE = 0 -- -- 01- 111 B ; "forced interlaced, fid=even"
HREFFO = 0 -- -- 01- 110 B ; "forced interlaced, fid=odd "
HREFN = 0 -- -- 01- 0-- B ; " horizontal reference "
BLANKI = 0 -- -- -00 1-- B ; " horizontal blanking "
BLANKN = 0 -- 0- -00 0-- B ; " horizontal blanking "
VEBLNK = 0 -- -- 00- -0- B ; " end of vertical sync "
VEBLNE = 0 -- -- 00- -11 B ; "forced interlaced, fid=even"
VEBLNO = 0 -- -- 00- -10 B ; "forced interlaced, fid=odd "

VS = 0 -- -- 1-0 --- B ; " vertical sync pulse "

WAIT = - -- 1- --- --- B ; " aux. wait cycle->RSTW "

BLIWAIT = 0 -- 1- -0- 1-- B ;
BLNWAIT = 0 -- 1- -0- 0-- B ;

TM = 0 -- -- --- --- B ; "escape from fifomode states"
FM = 1 -- -- --- --- B ; "escape from transp.m states"

" BOTH modes use the same
===== output flags/vector "

@OUTPUT VECTORS
"=====
[EOL, EOF] JKFFSR
EOLINE = 1 0 B ; " set EOL "
EOFIELD = 0 1 B ; " set EOF "
NEWFRAME = 1 1 B ; " set EOL & EOF, = RSTW "
FLAGSOFF = 0 0 B ; " reset EOL, EOF "

[ FBBIDJ,FBBIDK ]
FBBTOG = 1 1 B ; " toggle FBBID "
UPPERB = 1 0 B ; " pointer to upper fbb "
LOWERB = 0 1 B ; " pointer to lower fbb "

@STATE VECTORS
" two state machines on a single
===== 4-bit vector set "
[ Q3,Q2,Q1,Q0 ]
"for ===transparent=== mode"
IDLE = 0 0 0 0 B ; " idle "
LA = 0 0 0 1 B ; " this Line is/was Active "
FA = 0 0 1 0 B ; " this Field is/was Active "
VP = 0 0 1 1 B ; " vertical pause & reset "

```

## Desktop video demo board

DTV7194/96

```

" for === FIFO === mode "
INCHOT = 0 1 0 1 B ;      " incadr is low (hot to act) "
LINEND = 0 1 1 0 B ;      " hfl at inc-hot, issue eol "
VERTEND = 0 1 1 1 B ;      " after field increment "

COUNT0 = 1 0 0 0 B ;      " 8 additional states for"
COUNT1 = 1 0 0 1 B ;      "  fifo BURST count  "
COUNT2 = 1 0 1 0 B ;      "  =====  "
COUNT3 = 1 0 1 1 B ;      "  count through the  "
COUNT4 = 1 1 0 0 B ;      "  VCLK burst  "
COUNT5 = 1 1 0 1 B ;      "  Q3 to :  "
COUNT6 = 1 1 1 0 B ;      "  enable VCLK for VROport"
COUNT7 = 1 1 1 1 B ;      "  generate GATE for WPATH"
COUNT8 = 0 1 0 0 B ;      "  last cycle for gate "

```

## @TRANSITIONS

```

"===== " CASE-statements for === FIFO === mode"

```

```

WHILE [IDLE]
CASE [PX] "transparent mode"  :: [LA]          WITH [FLAGSOFF]
[HPULL]                       :: [COUNT0]    WITH [FLAGSOFF]
[INCLO]                       :: [INCHOT]      ENDCASE
WHILE [INCHOT]
CASE [LINC]                   :: [LINEND]     WITH [EOLINE]
[NEUTRAL]                     :: [VERTEND]    WITH [EOFIELD]
[TM]                          :: [IDLE]      ENDCASE
WHILE [LINEND]
CASE [NEUTRAL] WITH [FBBT0G]  :: [IDLE]
[TM]                          :: [IDLE]      ENDCASE
WHILE [VERTEND]
CASE [HPFULL]                 :: [VERTEND]    WITH [NEWFRAME]
[WAIT] WITH [UPPERB]         :: [IDLE]
[LINC] WITH [UPPERB]         :: [LINEND]
[TM]                          :: [IDLE]      ENDCASE

WHILE [COUNT0] CASE [] :: [COUNT1]  ENDCASE
WHILE [COUNT1] CASE [] :: [COUNT2]  ENDCASE
WHILE [COUNT2] CASE [] :: [COUNT3]  ENDCASE
WHILE [COUNT3] CASE [] :: [COUNT4]  ENDCASE
WHILE [COUNT4] CASE [] :: [COUNT5]  ENDCASE
WHILE [COUNT5] CASE [] :: [COUNT6]  ENDCASE
WHILE [COUNT6] CASE [] :: [COUNT7]  ENDCASE
WHILE [COUNT7] CASE [] :: [COUNT8]  ENDCASE
WHILE [COUNT8] CASE [] :: [IDLE]     ENDCASE

```

```

" IF-statements for === TRANSPARENT === mode "

```

```

WHILE [LA]
IF [BLANKI] THEN [LA] WITH [EOLINE]
IF [BLIWAIT] THEN [FA]
IF [BLANKN] THEN [LA] WITH [EOLINE]
IF [BLNWAIT] WITH [FBBT0G] THEN [FA]
IF [VS] THEN [VP] WITH [EOFIELD]
IF [FM] THEN [IDLE]
WHILE [FA]
IF [PX] THEN [LA] WITH [FLAGSOFF]
IF [VS] THEN [VP] WITH [EOFIELD]
IF [FM] THEN [IDLE]
WHILE [VP]
IF [HREFI] WITH [LOWERB] THEN [IDLE]
IF [HREFFE] WITH [FBBT0G] THEN [IDLE]
IF [HREFFO] WITH [LOWERB] THEN [IDLE]
IF [HREFFN] WITH [UPPERB] THEN [IDLE] WITH [NEWFRAME]
IF [VEBLNK] WITH [UPPERB] THEN [IDLE] WITH [NEWFRAME]
IF [VEBLNE] WITH [FBBT0G] THEN [IDLE]
IF [VEBLNO] WITH [UPPERB] THEN [IDLE] WITH [NEWFRAME]
IF [FM] THEN [IDLE]

```

## Desktop video demo board

DTV7194/96

WPD.EQN

```
" WPD      : DATA PATH interface VRO to frame buffer "
" ===== : multiplex for YUV and RGB bus formats  "
" PML2552  : marking data with eol, eof, alpha=key  "
" U17      : frame buffer write enable and reset   "
```

CONTROL, in byte 'SORT', under IIC address 44 hex

```
=====
SORT2  SORT1  SORT0
|      |      |
|      |      |      VRO data format
|      |      |      : RGB 15 bit, 5-5-5
|      |      |      : RGB 24 bit
|      |      |      : YUV (16 bit)
```

FBN : number of field buffer banks in use:

```
1 : one field buffer bank only
   (but do write-enable to both banks in parallel)
0 : two field buffer banks
   (before RSTW write eof-mark into both banks
    i.e. req. for 're-interlacing'
    non-interlaced into interlaced )
```

@PINLIST "pin-#"

```
CLKA  I ; " 36 : clock for input register "
CLKB  I ; " 24 : clock for input register "
CLKE1 I ; " 65 : clock for output register (main=GI) "
CLKE2 I ; " 56 : clock for output register (side=BI) "

HIBYT[7..0] I ; " Y in case of YUV-16 "
" RED in case of RGB-24 "
MIBYT[7..0] I ; " UV in case of YUV-16 "
" GREEN in case of RGB-24 "
LOBYT[7..0] I ; " not used in YUV-16 format "
" BLUE in case of RGB-24 "
ALPHA  I ; " 8 : alpha-bit, color key "

GI[7..0] O ; " GI - channel to FRAMs, also serial "
BI[7..0] O ; " BI - channel to FRAMs "

GATEPIN I ; " 51 : gate over VCLK-bursts,i.e.valid pixels"
EOLPIN  I ; " 52 : end-of-line (frame) marker "
EOFFPIN I ; " 53 : end-of-field/frame marker "
FBBIDIN I ; " 54 : frame buffer bank ID, to write to "

RSTW  O ; " 46 : reset of frame buffer write pointer "
WE1   O ; " 47 : write enable for frame buffer bank 1 "
WE2   O ; " 48 : write enable for frame buffer bank 2 "

STILL  I ; " 50 : STILL = 0 : freeze picture, no write "
SORT0  I ; " 23 : sort1=1 & sort0=1 : RGB15
" sort1=1 & sort0=0 : RGB24 "
SORT1  I ; " 22 : data format select:
" 1 : RGB 24 bit (15 bit) "
" 0 : YUV 16 bit "
SORT2  I ; " 20 : FBN, number of field buffer banks used
" 1 : one field buffer bank only "
" 0 : two field buffer banks "
```

@GROUPS

```
FILLV = [ 0,0,0,0, 0,0,0,1 ] ; " fifo fill pixel value "
KEYMARK = [ 0,0,0,0, 0,0,0,1 ] ; "transparent ALPHA pixel"
EOLMARK = [ 0,0,0,0, 0,0,0,0 ] ; " end of line marker "
EOFMARK = [ 1,1,1,1, 1,1,1,1 ] ; " end of field marker "
FBBEMARK = [ 1,1,1,1, 1,1,1,1 ] ; " field buffer bank end "
```

@TRUHTHABLE

## Desktop video demo board

DTV7194/96

```

@LOGIC EQUATIONS
FB2      = /SORT2 ;
FB1      =  SORT2 ;      " write into both FBs in parallel "
YUV      = /SORT1 ;
RGB24    =  SORT1 * /SORT0 ;
RGB15    =  SORT1 *  SORT0 ;
RGB      =  SORT1 ;
CLK      =  CLKB ;

" === INPUT REGISTER === "
ID[31..24] .ID = HIBYT[7..0] ;
ID[23..16] .ID = MIBYT[7..0] ;
ID[15.. 8] .D  = LOBYT[7..0] ;
ID[15.. 8] .SET = 1 ;      " 8 of 10 JKPR552 with "
KEY       .SET = 1 ;      " common set and clock "
KEY       .D  = ALPHA ;

ID[31..24] .CLK = CLKA ;
ID[23..16] .CLK = CLKB ;
ID[15.. 8] .CLK = CLK ;
KEY       .CLK = CLK ;

FBBIDN   .D  = /FBBIDN ;
EOL1     .D  = EOLPIN ;
EOF1     .D  = EOFPIN ;
EOL2     .D  = EOL1 ;      " to find leading edges "
EOF2     .D  = EOF1 ;
GATE     .D  = GATEPIN ;

" ---- declarations --- "
FBBIDN   .CLK = CLK ;
EOL1     .CLK = CLK ;
EOF1     .CLK = CLK ;
EOL2     .CLK = CLK ;
EOF2     .CLK = CLK ;
GATE     .CLK = CLK ;
WE1      .CLK = CLK ;
WE2      .CLK = CLK ;
RSTW     .CLK = CLK ;

" 10 * JKCL552 "
FBBIDN   .RST = /FB1 ;
EOL1     .RST = 1 ;
EOF1     .RST = 1 ;
EOL2     .RST = 1 ;
EOF2     .RST = 1 ;
GATE     .RST = 1 ;
WE1      .RST = /FREEZE ;      " .RST is active LOW "
WE2      .RST = /FREEZE ;
RSTW     .RST = 1 ;
FREEZE   .CLK = RSTW ;      " update with next frame"
FREEZE   .RST = 1 ;
FREEZE.D = /STILL ;      " 'still' is active low "
                        " 'freeze' is active high"

" ==== FLAGS DECODING & RESET CONTROL ==== "
EOLFLG   = EOL1 * /EOF1 * /EOL2 ;      " eol edge "
EOFFLG   = /EOL1 * EOF1 * /EOF2 ;      " eof edge "
FBBEFLG  = (EOL1 * EOF1) * /(EOL2 * EOF2) ;      " both 1st "
RSTWFLG  = (EOL1 * EOF1) * (EOL2 * EOF2) ;      " both /1st "
FLAGS    = EOLFLG + EOFFLG + FBBEFLG ;
FILLPIX  = ID[31..24] == 01H ;
BOTG8    = ID[23..17] == 00H ;      " catch and limit
                        green-undershoot"

```

## Desktop video demo board

DTV7194/96

```

" === MUX & MASK & MARK === "
GIR[7..3].OD = /KEY * /FLAGS * YUV * ID[31..27]
+ /KEY * /FLAGS * RGB24 * ID[23..19]
+ /KEY * /FLAGS * RGB15 * ID[25..21]
+ KEY * /FLAGS * 00H " KEYMARK "
+ EOLFLG * 00H " EOLMARK "
+ EOFFLG * 1FH " EOFMARK "
+ FBBEFLG * 1FH ; " FBBEMARK"

GIR[2..0].OD = /KEY * /FLAGS * YUV * ID[26..24]
+ /KEY * /FLAGS * RGB24 * ID[18..16] */BOTG8
+ /KEY * /FLAGS * RGB24 * 2H * BOTG8
+ /KEY * /FLAGS * RGB15 * 2H
+ KEY * /FLAGS * 1H " KEYMARK "
+ EOLFLG * 0H " EOLMARK "
+ EOFFLG * 7H " EOFMARK "
+ FBBEFLG * 7H ; " FBBEMARK"

BI[7..3].OD = YUV * ID[23..19]
+ RGB24 * ID[15..11]
+ RGB15 * ID[20..16] ;

BI[2..0].OD = YUV * ID[18..16]
+ RGB24 * ID[10.. 8]
+ RGB15 * 2H ;

" === OUTPUT REGISTER === "
GIR[7..0].CLK = CLK1 ;
BI[7..0].CLK = CLK2 ;
GI[7..0] = GIR[7..0] ;
GI[7..0].OE = WE1 + WE2 ;
RSTW . D = RSTWFLG ;
WE1 . D = GATE * YUV * ( /FBBIDN "+ FB1" ) * /FILLPIX
+ GATE * RGB * ( /FBBIDN "+ FB1" )
+ EOLFLG * ( /FBBIDN "+ FB1" )
+ EOFFLG * ( /FBBIDN "+ FB1" )
+ FBBEFLG ;
WE2 . D = GATE * YUV * ( FBBIDN + FB1 ) * /FILLPIX
+ GATE * RGB * ( FBBIDN + FB1 )
+ EOLFLG * ( FBBIDN + FB1 )
+ EOFFLG * ( FBBIDN + FB1 )
+ FBBEFLG ;

@INPUT VECTORS
@OUTPUT VECTORS
@STATE VECTORS
@TRANSITIONS

```



## Desktop video demo board

DTV7194/96

WREDD.EQN

```

" WREDD          : Multiplexer and register between
=====        : DESC VRO and field buffer in the
U18             : red channel: 24 bit / 15 bit
PL22V10

```

CONTROL

```

=====        SORT0 under IIC address 44 hex
1 : RGB15, i.e. 5 bit red
0 : RGB24, i.e. 8 bit red

```

@PINLIST

```

" pin # "
CLK I ; " 1 : clockf for all red channel "
ID[7..0] I ; " 9..2 : input from register U19 "
RI[7..0] O ; " 16..23 : output, to memory input "
SORT0 I ; " 11 : to control 8/5 bit multiplex "
SORT1 I ; " 15 : here not in use "
CLKAB I ; " 14 : here not in use "
" 13 : here not in use "

```

@GROUPS

@TRUTHTABLE

@LOGIC EQUATIONS

```

RGB24 = /SORT0 ;
RGB15 = SORT0 ;

```

```

RI [7..3] .D = RGB24 * ID[7..3] +
              RGB15 * ID[6..2] ;
RI [2..0] .D = RGB24 * ID[2..0] +
              RGB15 * 2H ;
RI [7..0] .CLK = CLK ;

```

@INPUT VECTORS

@OUTPUT VECTORS

@STATE VECTORS

@TRANSITIONS

## Desktop video demo board

DTV7194/96

RCD.EQN

```

" RCD = READ-CLOCK :   select clock and sync system   "
" =====           clock divider, clock drivers   "
" U41                 sync select                     "

@PINLIST      "pin-#   for PL22V10                    "

CLK I;        " 1 : dedicated clock input for PLD = pixclk "
CLKENC I;     " 2 : double pixel clock from DENC-clock-out, "
              " as selected by CLKSEL=VIEW3              "
PIXENC I;     " 3 : pixel clock from DENC-clock-out,      "
              " as selected by CLKSEL=VIEW3              "
LLC2B I;      " 4 : pixel clock of DESC as on eXp.port    "
EXTCLK B;     " 14 : external clock, here not used       "

MEMREAD O;    " 22 : read clock for FRAMS, luma/green channel "
REDCLK O;     " 21 : read clock for FRAMS, red & blue channel "
CLKE1 O;      " 20 : read/pixel clock, color difference     "
LDV O;        " 19 : pixel clock for output/display/DENC, LDV "
CLKMTV O;     " 18 : half pixel clock for MTV micro controller"

HSB I;        " 8 : horizontal sync at DESC's expansion port "
VSB I;        " 9 : vertical sync at DESC's expansion port   "
HSENC B;      " 17 : horizontal sync of/for DENC, active HIGH "
VSENC B;      " 16 : vertical sync of/for DENC, active HIGH  "
CBN O;        " 23 : CBN for DENC, inverted copy of HSENC   "

" VIEWx has I2C-address = 46 hex "
VIEW3 I;      " : here not used "
              " clock source select, display/read-clock "
              " @ pin CLKSEL of saa7199b "
              " view3 = 0 : CLKIN = LLCB of eXport "
              " view3 = 1 : LLC from DENC-CGC "
VIEW7 I;      " 6 : sync master select "
              " view7 = 0 : eXpans.Port = sync master "
              " (make sure: view3 = 0, too) "
              " view7 = 1 : DENC = sync master "

@GROUPS
@TRUTHTABLE

@LOGIC EQUATIONS

DENC = VIEW7 ; " DENC is sync timing master "
XPORT = /VIEW7 ; " sync timing signals from expansion port "

PIXCLOCK = XPORT * LLC2B
          + DENC * PIXENC ;

MEMREAD = PIXCLOCK ; " clock for FRAM- read interface"
REDCLK = PIXCLOCK ; " second driver "
LDV = PIXCLOCK ; " pixel clock = LDV "
CLKE1 = PIXCLOCK ;

CLKMTV.D = /CLKMTV ; " 1/2 pixel clock for uC "
CLKMTV.CLK = PIXENC ; " toggle by pixclk "

HSENC = XPORT * HSB ;
HSENC.OE = XPORT ;
VSENC = XPORT * VSYNCB ;
VSENC.OE = XPORT ;
CBN = XPORT * /HSB ; " blanking is active low "
      + DENC * /HSENC ;

@INPUT VECTORS
@OUTPUT VECTORS
@STATE VECTORS
@TRANSITIONS

```

## Desktop video demo board

DTV7194/96

## RVD.EQN

```

" RVD : READV : vertical start of display window FSGO "
" ===== memory read pointer reset RSTR "
" PML2552-35 background data path pass through "
" VCTRL check for MTV micro RGB overlay "
" U37 OVL = overlay insert, maybe used as MPK "

```

```

CONTROL PARAMETER in byte VIEW, I2C-address = 46 hex
=====

```

VIEW7	VIEW6	VIEW5	VIEW4	VIEW3	VIEW2	VIEW1	VIEW0
							1: MTV-RGB overlay inserted in data path (native mode if SAA7199 is used for output) MPK carries (RGB) tagging information for LUT 0: MTV overlay is NOT inserted in data (native mode if DACs for RGB output is used) but MPK carries switching information
							Four modi for display sync- and data path: Syncs from : Background signal :
	0	0	DECoder (DESC, XPT)		eXPansionPort/2 in/out		
	0	1	DECoder (DESC, XPT)		count- pattern, INTRL		
	1	0	ENCOder, g1/master		count pattern, INTRL		
	1	1	VGA:				
					ENCOder double clock generated pattern		
					--> double H+V-rate, (every 2nd VS suppressed)		

## @PINLIST

"pin-nr"

```

CLKA I ; " 36 : pixel-clock, all clocks "
CLKB I ; " 24 : pixel clock, same as LDV, "
CLKE1 I ; " 65 : pixel clock, for display, "
CLKE2 I ; " 56 : pixel clock, i.e. output "

VOS[7..0] I ; " Vertical Offset of inserted window "
BY [7..0] I ; " background luminance channel, Y "
BUV[7..1] I ; " background chrominance channel, UV "
" background = signal at expansion port "
YW [7..0] O ; " luminance output, respectively Green "
UWV[7..0] O ; " colour difference output, resp. Blue "

VSENC B ; " 46 : VS at ENC, vertical sync, active HI "
HS2RD I ; " 47 : half line pulse from READH-pld "
" 1.half-line LOW, 2nd half of line HIGH"
RSTR O ; " 48 : reset read pointer for both FRAM banks"
OVL O ; " 50 : insert MTV-overlay, switches RGB-yuv "
VSL O ; " 51 : extented vertical sync for sandcastle "
FSGO O ; " 53 : indicates vertical start of window "
" INTRL : FSGO takes FID at VWBegin, "
" NINTRL : FSGO = line pulse at VWBegin "
KEY I ; " 54 : active (LOW) during inserted picture "
" to control data output enable "
" also used as KEY, if ENC in genlock "

VIEW4 I ; " 23 : view4 = 1 : code OVL "
VIEW5 I ; " 22 : background signal: "
view5 = 0 : XPORT 1/2 intensity "
view5 = 1 : color pattern, or VGA "
VIEW6 I ; " 20 : timing master (sync) : "
view6 = 0 : DESC-eXPansion-Port, "
i.e. ENC is slave "
view6 = 1 : ENC is sync master "
( view6 = 1: VGA mode ) "

VCTRL I ; " 8 : RGB overlay from micro controller->MPK"
MTVG I ; " 52 : green overlay from MTV "
MTVB I ; " 45 : blue overlay from MTV "
" sacrifice LSB of background color "

```

## Desktop video demo board

DTV7194/96

```

@GROUPS
@TRUHTTABLE

" MODI truth table ( as in equation: === MODE CONTROL TABLE ==="
[ VIEW6, VIEW5, VIEW4 : DECS, ENCS, VGA, PATTERN, OVLE, RGBONYUV ]
  0 0 0      : 1 0 0 0 1 0 ;
  0 0 1      : 1 0 0 0 0 0 ;
  0 1 0      : 1 0 0 0 1 1 ;
  0 1 1      : 1 0 0 1 0 0 ;
  1 0 0      : 0 1 0 1 1 0 ;
  1 0 1      : 0 1 0 1 0 0 ;
  1 1 0      : 0 1 1 1 1 0 ;
  1 1 1      : 0 1 1 1 0 0 ;

@LOGIC EQUATIONS

" === MODE CONTROL TABLE === "
XPORTB = /PATTERN ;
PIP     = /KEY ;
" window is active low in order to be used @ DENC-KEY "

" === HORIZONTAL CLOCKS === "
CLK     = CLKB ;
HS2 .D  = HS2RD ;      " 1st half line LOW, then HIGH "
CNTCLK  = /HS2 ;      " ----- FULL LINE CLOCK ----- "

" === REGISTER declarations === "
" .SET guides snap to use 9 JKPR552 with
" common clock and common preset "
" edges produce half line clocks "
HS2     .SET = 1 ;
HS2     .CLK = CLK ;
VQ[2..0].SET = 1 ;      " state machine register "
VQ[2..0].CLK = CLK ;
FSGO    .SET = 1 ;      " indirect state register "
FSGO    .CLK = CLK ;
FSGO    .J  = FSGOJ ;
FSGO    .K  = FSGOK ;
INTRL   .SET = 1 ;      " auxilliary control state "
INTRL   .CLK = CLK ;
FID     .SET = 1 ;      " internal control state "
FID     .CLK = CLK ;
VSL     .SET = 1 ;      " vertical sync long "
VSL     .CLK = CLK ;
VSL     .J  = VSLJ ;
VSL     .K  = VSLK ;
CPHASE  .SET = 1 ;      " u/v multiplex phase "
CPHASE  .CLK = CLK ;      " for color pattern "
VCTRL1D .SET = 1 ;
VCTRL2D .SET = 1 ;      " MPK switches SAA7199 into "
VCTRL1D .CLK = CLK ;      " foreground RGB overlay "
VCTRL2D .CLK = CLK ;

" === COUNT VERTICAL ==="
".RST guides snap to use 8 JKCL552
" with _individual_ clock inputs and _individual_ clear,
" but asynchronous clear, which gets
" 'synchronized', i.e. 'gated' by VQ state machine "
COUNT[7..0].J = 1 ;
COUNT[7..0].K = 1 ;
COUNT[7..0].RST = /CNTRST ;
COUNT0.CLK = CNTCLK ;
COUNT1.CLK = /(CNTCLK * COUNT0) ;
COUNT2.CLK = /(CNTCLK * COUNT0*COUNT1) ;
COUNT3.CLK = /(CNTCLK * COUNT0*COUNT1*COUNT2) ;
COUNT4.CLK = /(CNTCLK * COUNT0*COUNT1*COUNT2*COUNT3) ;
COUNT5.CLK = /(CNTCLK * COUNT0*COUNT1*COUNT2*COUNT3*COUNT4) ;
COUNT6.CLK = /(CNTCLK * COUNT0*COUNT1*COUNT2*COUNT3*COUNT4
*COUNT5) ;
COUNT7.CLK = /(CNTCLK * COUNT0*COUNT1*COUNT2*COUNT3*COUNT4
*COUNT5*COUNT6) ;

```

## Desktop video demo board

DTV7194/96

```

"=== VERTICAL EVENTS ==="
VSI      =  VSENC ;                " VSENC from ENC "

"--- VERTICAL BLANKING INTERVAL---"
VBEND    =  COUNT[7..0] == 10H ;   " about 16 lines = 10hex "

" --- VSLong for sandcastle --- "
VSLE     =  COUNT[7..0] == 0AH ;   " 10 or 10.5 lines "

" for simulation purposes ONLY "
"vbend   =  count[7..0] == 07H ;   "      7 "
"VSLE    =  COUNT[7..0] == 05H ;   "      5 "

" --- VERTICAL WINDOW BEGIN --- "
VWB      =  COUNT[7..0] == VOS[7..0] ; " input to state machine "

" === COLOR TEST PATTERN === "
PATL7    =  COUNT7 ** ( FID + /FID * HS2 ) " ;
PATL[6..0] = 40H ;

PATC7    =  HS2 * INTRL * COUNT5 ;
PATC[6..0] = 40H ;

IDB[7..1].ID = BY [7..1] ;        " luminance background "
LUMA[5..0]   = IDB[6..1] ;        " ===== 1/2 contrast "
LUMA6        = /IDB7 ;           " brightness offset "
LUMA7        = IDB7 ;           " sign extension "
IDB[7..1].CLK = CLKB ;

IDA[7..1].ID = BUV[7..1] ;        " color diff. background"
COLR[5..0]   = IDA[6..1] ;        " ===== 1/2 saturation"
COLR6        = /IDA7 ;           " offset binary "
COLR7        = IDA7 ;           " sign extension "
IDA[7..1].CLK = CLKA ;

"=== MTV RGB OVERLAY ==="
VCTRL1D.D = VCTRL ;
VCTRL2D.D = VCTRL1D ;
OVLG.CLK  = CLKB ;
OVLB.CLK  = CLKA ;
OVLG.ID   = MTVG ;           " IDB0 "           " 100% saturation 75% "
OVLB.ID   = MTVB ;           " IDA0 "           " dec hex : dec hex "
BLACK[7..0] = 10H ;         " 16 10 : 16 10 "
GREEN[7..0] = B4H ;         " 235 EB : 180 B4 "
BLUE [7..0] = B4H ;         " 235 EB : 180 B4 "
OVLGREEN[7..0] = OVLG * GREEN[7..0] ;           " green overlay "
               + /OVLG * BLACK[7..0] ;
OVLBLUE[7..0] = OVLB * BLUE [7..0] ;           " blue overlay "
               + /OVLB * BLACK[7..0] ;
OVLAY     = VCTRL1D * OVLG ;

" === DATA OUTPUT ==="
Y [7..0].OD = /OVLAY * ( PATTERN * PATL[7..0] +
                       XPORTb * LUMA[7..0] )
               + OVLAY * OVLGREEN[7..0] ;
UV[7..0].OD = /OVLAY * ( PATTERN * PATC[7..0] +
                       XPORTb * COLR[7..0] )
               + OVLAY * OVLBLUE[7..0] ;

OVL       = VCTRL2D + PIP * RGBONYUV ;        " MPK is active high "
OUTABLE   = VCTRL2D + /PIP ;

Y [7..0].CLK = CLKE2 ;
UV[7..0].CLK = CLKE1 ;
YW [7..0]    = Y [7..0] ;
UVW[7..0]    = UV[7..0] ;

YW [7..0].OE = OUTABLE ;
UVW[7..0].OE = OUTABLE ;

```

## Desktop video demo board

DTV7194/96

```

@INPUT VECTORS
    " for VQ vertical state machine, for FSGO etc."
    " ===== "
[ ENCS,VGA, VSI,HS2RD,HS2, INTRL,FID, VSLE,VBEND,VWB ]

VSI1Z  = -0 100 -- --- B; " to reset counter "
VS1    = -- 110 -- --- B; " VS rose in 1st half line,
    'even' 2nd field, fid=> 0 "
VSI2Z  = -0 111 -- --- B; " to reset counter "
VS2    = -- 101 -- --- B; " VS rose in 2nd half line,
    'odd' 1st field, fid=> 1 "
VSI2XZ = -- 111 -- --- B; " don't check for interlace "
VSLEND = -- -01 -- 1-- B;
VSVGA  = -1 1-- -- --- B;
VSEND  = -- 0-- -- --- B;
ENDVBI = -- -00 -- -1- B; " end of VBI, enter LINE ZERO"
MIDLINE = -- -10 -- --- B; " reset counter for active v."
NEXTLINE = -- -01 -- --- B; " line zero --> IDLETOP "
    " or toggle FSGO --> VWB1 "
VWBEGOF = -- -11 11 --1 B; " rstr in odd field "
VWBEGNI = -- -11 0- --1 B; " rstr if non interlaced"
VWBEGLE = -- -01 -- --1 B; " line end--> vwbl "
EVNFNL  = -- -01 10 --- B;
ODDFNL  = -- -01 11 --- B;
NONINL  = -- -01 0- --- B;

    " for INRTL-FID state machine "
    " ===== "
[ TF1, TF0 ]
VSODD  = 1 0 B;
VSEVEN = 0 1 B;

@OUTPUT VECTORS
[ CNTRST, TF1, TF0, VSLJ, VSLK, RSTR, FSGOJ, FSGOK ]
COUNTRST = 1 0 0 0 0 0 0 0 0 B;
TICFID1  = 0 0 1 0 1 0 0 0 0 B;
TICFID0  = 0 0 1 1 0 0 0 0 0 B;
VSLRST   = 0 0 0 0 1 0 0 0 0 B;
FBRESET  = 0 0 0 0 0 1 0 0 0 B;
GOTOGGLE = 0 0 0 0 0 0 1 1 1 B;
GOCLEAR  = 0 0 0 0 0 0 0 1 1 B;
GOSET    = 0 0 0 0 0 0 1 0 0 B;

@STATE VECTORS
[ VQ2,VQ1,VQ0 ] " vertical states "
VBI = 1 1 1 B; " keep free: 16 + 1 line "
LINEZERO = 0 0 0 B; " counter restart for act. video"
IDLETOP = 0 0 1 B; " above Vertical Window Begin "
VWB1 = 0 1 0 B; " flag window start, issue FSGO "
IDLEBOT = 0 1 1 B; " after window begin, till VS "
VGA2VS = 1 0 0 B; " jump over 2nd VS in VGA mode "
VGABOT = 1 0 1 B; " and after that "
DUMMY = 1 1 0 B;

[ INTRL, FID ] " interlaced & field ID states"
FIELD1 = 1 1 B; " interlaced: field 1 "
FIELD2 = 1 0 B; " interlaced: field 2 "
NINT1 = 0 1 B; " likes odd field "
NINT0 = 0 0 B; " likes evn field "

@TRANSITIONS
    " VQ vertical state machine "
WHILE [VBI]
    IF [VSLEND] WITH [VSLRST] THEN [VBI]
    IF [ENDVBI] THEN [LINEZERO]

```

## Desktop video demo board

DTV7194/96

```

WHILE [LINEZERO]
  IF [MIDLINE] WITH [COUNTRST] THEN [LINEZERO]
  IF [NEXTLINE] THEN [IDLETOP]

WHILE [IDLETOP]
  IF [VS1IZ] WITH [COUNTRST] THEN [IDLETOP]
  IF [VS1] WITH [TICFID0] THEN [VBI]
  IF [VS2IZ] WITH [COUNTRST] THEN [IDLETOP]
  IF [VS2] WITH [TICFID1] THEN [VBI]
  IF [VSVGGA] THEN [VGA2VS]
  IF [VWBEGOF] WITH [FBRESET] THEN [IDLETOP]
  IF [VWBEGNI] WITH [FBRESET] THEN [IDLETOP]
  IF [VWBEGLE] WITH [GOTOGGLE] THEN [VWB1]

WHILE [VWB1]
  IF [ODDFNL] WITH [GOSET] THEN [IDLEBOT]
  IF [EVNPNL] WITH [GOCLEAR] THEN [IDLEBOT]
  IF [NONINL] WITH [GOCLEAR] THEN [IDLEBOT]

WHILE [IDLEBOT]
  IF [VS1IZ] WITH [COUNTRST] THEN [IDLEBOT]
  IF [VS1] WITH [TICFID0] THEN [VBI]
  IF [VS2IZ] WITH [COUNTRST] THEN [IDLEBOT]
  IF [VS2] WITH [TICFID1] THEN [VBI]
  IF [VSVGGA] THEN [VGA2VS]

WHILE [VGA2VS]
  IF [VSEND] THEN [VGABOT]
WHILE [VGABOT]
  IF [VS2XZ] WITH [COUNTRST] THEN [VGABOT]
  IF [VS2] WITH [TICFID1] THEN [VBI]

WHILE [DUMMY]
  IF [ ] THEN [IDLEBOT]

" INTRL-FID state machine, 'spinning wheel' for interlaced"

WHILE [FIELD1] "11"
  IF [VSEVEN] THEN [FIELD2] "10"
  IF [VSODD] THEN [NINT0] "00"
WHILE [FIELD2] "10"
  IF [VSEVEN] THEN [NINT1] "01"
  IF [VSODD] THEN [FIELD1] "11"
WHILE [NINT1] "01"
  IF [VSEVEN] THEN [NINT0] "00"
  IF [VSODD] THEN [NINT1] "01"
WHILE [NINT0] "00"
  IF [VSEVEN] THEN [NINT0] "00"
  IF [VSODD] THEN [FIELD1] "11"

```

## Desktop video demo board

DTV7194/96

RHD.EQN

```

" RHD = ReadH : horizontal definition of display window "
" ===== generation of half-line signal HS2RD "
" PML2552-35 memory READ control, FBBID, RE1, RE2, "
" data path check for eol/eof/key marker "
" U36 data path gating, OE "
"
CONTROL PARAMETER
=====
VIEW3 VIEW2 VIEW1 VIEW0
          1 : non-interlaced display
          0 : interlaced display

          1 : 50Hz, 944 clocks per H-line
          0 : 60Hz, 780 clocks per H-line

          1 : one field buffer bank only
          0 : two field buffers in use

clock direction, not relevant for READH, but for READCLK
1 : clock from encoder-CGC, e.g. genlock, or stand-alone
0 : clock from decoder to encoder, RTC-lock-operation,
   e.g. slave mode, stand-alone mode "

@PINLIST "pin-#"

CLKA I ; " 36 : MEMREAD, memory read clock, pixel clock,
          for byte-serial-mode, this is 2* pixel-clk"
CLKB I ; " 24 : pixel clock, also for internal count "
CLKE2 I ; " 56 : pixel clock, same as LDV, for YW,
          for output, i.e. display "
CLKE1 I ; " 65 : for UVW, parallel-mode: same as LDV = clke2
          serial-mode: clke1 = /LDV, i.e.like clkIn;
          half period shifted clock = inverted clock"

GO[7..0] I ; " luma input channel, Y,Green, or serial"
BO[7..0] I ; " color diff. input channel, UV, Blue "
HOS[8..1] I ; " Horizontal OffSet of inserted window "
          " I2C address: 48 hex "
YW[7..0] O ; " luminance output, respectively Green "
UVW[7..0] O ; " colour difference, resp. Blue "

HSENC I ; " 46 : HSN of DENC, horiz.sync, active HIGH "
HS2RD O ; " 47 : 1st half line LOW, 2nd half line HIGH "
RE1 O ; " 48 : read enable FRAM bank 1 "
RE2 O ; " 50 : read enable FRAM bank 2 "
OVL I ; " 51 : overlay by MTV, propagated by RVD-pld "
          " could be used as MUTE from external "
WINDOW O ; " 52 : active HIGH during inserted signal "
FSGO I ; " 53 : indicates vertical start of window "
          " interlaced output (view1=0):
          FSGO changes to FID at VW-start "
          " non-interl.output (view1=1):
          FSGO = line pulse at VW-start "
KEY O ; " 54 : active LOW if PIP or overlay "
INSERT I ; " 8 : insert of scaled signal (PIP) "

          " VIEWx has I2C address = 46hex "
VIEW0 I ; " 23 : FBBID toggle mode, if 2 FBBanks
          1 : non-interlaced out --> field toggle
          0 : INTERLaced display --> line toggle
          if only single field buffer: no toggle"
VIEW1 I ; " 22 : pixels-per-line selection, 50/60 Hz SQP
          1 : 50HzSQP: 944 pixel clocks / H-line
          0 : 60HzSQP: 780 pixel clocks / H-line"
VIEW2 I ; " 20 : FBB modes, one or two FBBanks in use
          1 : 1 FBB only, FBBID fix=1, no toggle
          0 : 2 FBB active, FBBID toggle enabled,
          FBBID set to 1 @ FSGO rising edge
          (FBBID = 1 points to the UPPER bank "

```



## Desktop video demo board

DTV7194/96

```

@GROUPS
"EOLMARK = [ 0,0,0,0, 0,0,0,0 ] ; "      " end of line marker "
"BOFMARK = [ 1,1,1,1, 1,1,1,1 ] ; "      " end of field marker "
"KEYMARK = [ 0,0,0,0, 0,0,0,1 ] ; "      " color key marker,i.e.
                                         a transparent pixel "

@TRUTHTABLE

@LOGIC EQUATIONS

INTRL = /VIEW0 ;          " interlaced display "
SQ50 = VIEW1 ;
SQ60 = /VIEW1 ;
FB1 = VIEW2 ;           " 1 frame buffer bank only "

" === REGISTER & CLOCKS === "
CLK = CLKB ;           " declarations "
HBL .CLK = CLK ;
HS2RD .CLK = CLK ;
RQ[2..0].CLK = CLK ;
FBBID .CLK = CLK ;
WINDK .CLK = CLK;
RE1 .CLK = CLK;
RE2 .CLK = CLK;

HBL .SET = 1;          " state register "
HS2RD .SET = 1;       " state register "
RQ[2..0].SET = 1;     " state registers "
FBBID .SET = 1;       " set and toggle via state machine "
" 1 = upper=odd, 0 = lower=even "

WINDO .SET = 1;       " to enable the data output "
WINDK .SET = 1;       " to send a 'window' signal "
RE1 .SET = 1;
RE2 .SET = 1;

" === HORIZONTAL COUNT === "
" .rst guides snap to use 10 * JKCL552 with individual "
COUNT[9..0].RST = /CNTRST ; " reset and individual clock "
COUNT[9..0].J = 1 ;
COUNT[9..0].K = 1 ;
COUNT0.CLK = CLK ;
COUNT1.CLK = /(CLK * COUNT0) ;
COUNT2.CLK = /(CLK * COUNT0*COUNT1) ;
COUNT3.CLK = /(CLK * COUNT0*COUNT1*COUNT2) ;
COUNT4.CLK = /(CLK * COUNT0*COUNT1*COUNT2*COUNT3) ;
COUNT5.CLK = /(CLK * COUNT0*COUNT1*COUNT2*COUNT3*COUNT4) ;
COUNT6.CLK = /(CLK * COUNT0*COUNT1*COUNT2*COUNT3*COUNT4
*COUNT5) ;
COUNT7.CLK = /(CLK * COUNT0*COUNT1*COUNT2*COUNT3*COUNT4
*COUNT5*COUNT6) ;
COUNT8.CLK = /(CLK * COUNT0*COUNT1*COUNT2*COUNT3*COUNT4
*COUNT5*COUNT6*COUNT7) ;
COUNT9.CLK = /(CLK * COUNT0*COUNT1*COUNT2*COUNT3*COUNT4
*COUNT5*COUNT6*COUNT7*COUNT8) ;

" === HORIZONTAL EVENTS === "
HOSO = 0 ;           " to adjust for uv-sequence "
HOS9 = 0 ;

HBL . J = HSD ;
TRIGGER = HSD * /HBL ; " rising edge is leading edge "
HS2RD.K = HBL * COUNT[9..0] == 023H ; " 35 = some room "
RESTART = HBL * COUNT[9..0] == 05FH * SQ60 " 140 - 45 = 95 "
+ HBL * COUNT[9..0] == 083H * SQ50 ; " 176 - 45 = 131 "
" restart to position HWB in 'active line' only "
CNTRST = TRIGGER + RESTART ;

```

## Desktop video demo board

DTV7194/96

```

HBL . K = /HSD * COUNT[9..0] == 001H ;      " after 2nd restart "
CLAMP = HBL * (COUNT[7..4] == 0011B +      " from count=48 "
              COUNT[7..5] == 010B ) ;      " to count=95 "
              " insert RGB reference values for sandcastle clamp "
BLANK = HBL * /HS2RD ;                      " yuv = 'null' "
              " mid line n*fh/2 - 'front blank' = "
MIDLINE = SQ60 * (COUNT[9..0] == 149H) +   " 780/2 - ( 95-35) "
          SQ50 * (COUNT[9..0] == 177H) ;   " 944/2 - (131-35) "
HS2RD.J = /HBL * MIDLINE ;
HWB = /HBL * COUNT[9..0] == HOS[9..0] ;
          "horizontal window begin, after vertical window begin"

          " === CONTROL & OUT === "
EOL = IDA[7..0] == 00H ; "EOLMARK = end of line marker "
EOF = IDA[7..0] == FPB ; "EOFMARK = end of field marker "
KEY = IDA[7..0] == 01H ; "KEYMARK = color key marker,
                          i.e. transparent pixel "
TPIX = EOL + EOF + KEY ; " this is not a pixel to display "
OVLAY = OVL ;
WINDR = /RQ2*RQ1*RQ0 * /TPIX ; " have read (good) data "
WINDO.D = (WINDR*INSERT + BLANK) * /OVLAY ; " output data "
WINDK.D = /(WINDR*INSERT + BLANK + OVLAY) ; " use as DENC KEY "

          " === DATA PATH THRU === "
IDA[7..0].ID = GO[7..0] ;
IDA[7..0].CLK = CLKA ;
IDB[7..0].ID = BO[7..0] ;
IDB[7..0].CLK = CLKB ;

Y [7..0].OD = /BLANK * IDA[7..0] + BLANK * 10H ;
UV [7..0].OD = /BLANK * IDB[7..0] + BLANK*/CLAMP * 80H
              + CLAMP * 10H ;

Y [7..0].CLK = CLKE2 ;
UV [7..0].CLK = CLKE1 ;

YW [7..0] = Y [7..0] ;
UVW[7..0] = UV[7..0] ;
YW [7..0].OE = WINDO * /OVL ;
UVW[7..0].OE = WINDO * /OVL ;
WINDOW = WINDK + OVL ; " window is active high "
KEY = /WINDOW ; " key is active low "

@INPUT VECTORS

[ FSGO,HBL ,HWB, EOL,EOF,
  IDA7,IDA6,IDA5,IDA4,IDA3,IDA2,IDA1,IDA0,
  INTRL,FBI,FBBID ]
FSGUP = 1 1 - - - - - B; "also FSGO line pulse"
FSGDN = 0 1 - - - - - B; " from odd to even "
WAIT = - - 0 - - - - - B;
HSTARTU = - 0 1 - - - - - B; "H-window begin Upper"
HSTARTL = - 0 1 - - - - - B; "H-window begin Lower"
NOFLAG = - - - 0 0 - - - B;
EOLI = - - - 1 - - - - - B;
EOLN2U = - - - 1 - - - - - 001 B; " toggle to lower "
EOLN2L = - - - 1 - - - - - 000 B; " toggle to upper "
EOLN1 = - - - 1 - - - - - 01- B;
EOFODD2 = 1 - - - 1 - - - - - 101 B; " toggle to lower "
EOFODD1 = 1 - - - 1 - - - - - 11- B;
EOFEVN = 0 - - - 1 - - - - - B; " set fbbid anyhow "

@OUTPUT VECTORS " FBBID : where to read from "

[ FBBID, RE1, RE2 ] JKFFS
FBBLO = 0 0 0 B; " set to lower field buffer bank"
FBBUP = 1 0 0 B; " set to upper field buffer bank"
DUMREAD = 1 1 1 B; " dummy read at window-frame begin "
READU = - 1 0 B; " read from upper FBB "
READL = - 0 1 B; " read from lower FBB "
NOREAD = - 0 0 B; " stop reading after EO-marker "

```

## Desktop video demo board

DTV7194/96

## @STATE VECTORS

```

      [ RQ2,RQ1,RQ0 ] JKFFS      " === for WINACT === "
DUMMY2 = 0  0  0  B;      " 2nd dummy read at window begin "
IDLODD = 0  0  1  B;
IDLEVN = 0  1  0  B;      " display zones and "
WINACT = 0  1  1  B;      " window generation "
RIBBON = 1  0  0  B;
FIRST  = 1  0  1  B;      " read 1st tristate "
SECOND = 1  1  0  B;      " read 2nd tristate "
LAST1  = 1  1  1  B;      " check for eof "

```

## @TRANSITIONS

```

" There is a pipeline delay until an eol or eof marker is
detected. In that moment - as an eol marker is found - there
are already initiated two more reads from FRAM,
i.e. the first two pixels of the next line are already read.
These first two pixels of every line get lost.
At the begin of a frame buffer bank, i.e. for the first line,
two pixels have to be thrown away artificially : an extra read
at vertical window begin and excursing loop via dummy2.
If an end of field is indicated by a plain eof marker (no
preceding eol, irregular case) there get two pixels lost, too.
If an end of field is indicated by a sequence of eol and eof
marker (regular case) only one pixel gets lost. "

```

```

WHILE [IDLEVN]
  IF [FSGUP]      THEN [DUMMY2]  WITH [DUMREAD]
  " for parity, throw first 2 pixel of Frame Buffer Bank away, "
  " like first 2 pixel of other lines "

```

```

WHILE [IDLODD]
  IF [FSGDN]      THEN [RIBBON]
  IF [WAIT]       THEN [IDLODD]  WITH [NOREAD]

```

```

WHILE [DUMMY2]
  IF []           THEN [RIBBON]

```

```

WHILE [RIBBON]
  IF [HSTARTU]    THEN [FIRST]   WITH [READU]
  IF [HSTARTL]    THEN [FIRST]   WITH [READL]
  IF [WAIT]       THEN [RIBBON]  WITH [NOREAD]

```

```

" first, second : from issue a 'read' to FRAM to receiving
related 'correct' data in PLD there is a pipeline delay of
2 clocks. Don't use these intermediate data.
Don't check for 'eol' or 'eof', as there is rubbish in pipe. "

```

```

WHILE [FIRST]
  IF []           THEN [SECOND]
WHILE [SECOND]
  IF []           THEN [WINACT]

```

```

WHILE [WINACT]
  IF [EOL1]       THEN [LAST1]   WITH [NOREAD]
  IF [EOLN1]      THEN [LAST1]   WITH [NOREAD]
  IF [EOLN2U]     THEN [LAST1]   WITH [FBBLO]
  IF [EOLN2L]     THEN [LAST1]   WITH [FBBUP]
  IF [EOFODD2]    THEN [IDLODD]   WITH [FBBLO]
  IF [EOFODD1]    THEN [IDLEVN]   WITH [NOREAD]
  IF [EOFEVN]     THEN [IDLEVN]   WITH [NOREAD]

```

```

WHILE [LAST1]      " check last+1 'read' for eof "
  "last+1 pixel = first pixel of next line, lost in the pipe "
  IF [EOFODD2]    THEN [IDLODD]   WITH [FBBLO]
  IF [EOFODD1]    THEN [IDLODD]   WITH [DUMREAD]
  IF [EOFEVN]     THEN [IDLEVN]
  IF [NOFLAG]     THEN [RIBBON]

```

## Desktop video demo board

DTV7194/96

```

RREDD.EQN

" RREDD : insert red for MTV-red for menu overlay
U38      Also insert of blank level during CBN
PL22V10

"

@PINLIST      " pin # "

REDCLK  I ; " 1 : pixel clock for red channel "
RO[7..0] I ; " 2..9 : Red channel from FRAM memory "
VCTRL  I ; " 11 : overlay control "
MTVRED  I ; " 13 : overlay black/red select "

OUT[7..0] O ; " 23..16: output after register "
PIXCLK  I ; " 14 : here not used "
CBN     I ; " 15 : to insert clamp reference BLACK
          CBN is active low during blank "

@GROUPS
@TRUTHTABLE
@LOGIC EQUATIONS

BLACK [7..0] = 10H ;
RED [7..0] = B4H ; " 100% = EB, 75% = B4 "
OUT[7..0] .D = VCTRL * /MTVRED * BLACK [7..0]
              + VCTRL * MTVRED * RED [7..0]
              + /VCTRL * /CBN * BLACK [7..0]
              + /VCTRL * CBN * RO [7..0] ;

OUT[7..0] .CLK = REDCLK ;

@INPUT VECTORS
@OUTPUT VECTORS
@STATE VECTORS
@TRANSITIONS

```

## Desktop video demo board

DTV7194/96

CASTLD.EQN

```

" CASTLD : generation of SANDCASTLE timing for
===== TDA4686, and sync signals for
U26      RGB monitor output
PLC42VA12 ( or PL22V10 )

```

TASK

```

==== castl gets - horizontal sync/blanking - active high
          (leading edge is used as timing reference)
          and - vertical syncs : VSENC and VSLong)
castl delivers :
- combined vertical and horizontal blanking as CBLANK
- sandcastle HCLAMP signal,
    to construct externally 'analog' sandcastle pulse
- horizontal sync HSYCM and vertical sync VSYNCM
  for RGB monitor timing, both selectable in polarity
castl counts horizontally with CLKMTV, half the pixel rate

```

CONTROL PARAMETER

```

=====
COSY (SORT3)
  1 : HSYNCM is Composite Sync for Monitor, like CBLANK
  0 : horizontal and vertical sync on separate wires

POLH (SORT6) # hsP : select polarity of HSYNCM for monitor
  1 : positive sync pulse   0 : negative sync pulse

POLV (SORT7) # vsP : select polarity of VSYNCM for monitor
  1 : positive sync pulse   0 : negative sync pulse

```

Concept :

```

=====      5 bit counter and
              2 bit statemachine (blank, clamp)
HSENC triggers counter:
              enable counting
              begin H blanking
              reset counter
count 24      (48 pixclk): then begin H sync
              begin H clamp
count 12 more (24 pixclk): then reset counter
count 12      (24 pixclk): then end H clamp
count 18 more (36 pixclk): then reset counter
count 4       ( 8 pixclk): then end H sync
              end H blanking
count 26 more (52 pixclk): then stop counting
              wait for next HSENC trigger

```

```

HSYNCM is copy of internal horizontal sync timing
VSYNCM is copy of selected VSLong (10 lines) timing
CBLANK is 'or' of VSLong and Hblank

```

```

@PINLIST      "pin-#"
CLKMTV I ;    " 1 : half pixel clock, CLKMTV "
CBN I ;      " 2 : composite blanking, here not used "
VSL I ;      " 3 : VSX, vsd or vsx carries VSLong "
VSENC I ;    " 4 : VSN @ DENC, vertical sync, active High "
HSENC I ;    " 5 : HSN @ DENC, horizontal sync, active High "
COSY I ;     " 6 : monitor sync composite or separate (SORT4)
              1 : composite sync on HSYNCM
              0 : separate syncs VSYNCM and HSYNCM "
POLH I ;     " 8 : polarity of HSYNCM for monitor (SORT6) "
POLV I ;     " 8 : polarity of VSYNCM for monitor (SORT7) "

HSYNCM O ;   " 20 : for monitor H synchronisation "
VSYNCM O ;   " 21 : for monitor V synchronisation "
CBLANK O ;   " 22 : composite blanking for sandcastle "
HCLAMP O ;   " 23 : clamp part of sandcastle, 'burst key' "

hq0 o ;     " 16 : for test purposes only "
hq1 o ;     " 15 : for test purposes only "

```

## Desktop video demo board

DTV7194/96

```

@GROUPS
@TRUTHTABLE
@LOGIC EQUATIONS

      " === REGISTER & CLOCKS === "
      "   declarations   "
CLK      = CLKMTV ;
HQ[1..0].CLK = CLK ;
HQ[1..0].SET = 1 ;

      " state machine registers "

      " === HORIZONTAL COUNT === "
      "   from state machine "
COUNT[4..0].RST = /CNTRST ;
COUNT[4..0].J = /CNTHLD ;
COUNT[4..0].K = /CNTHLD ;
COUNT0.CLK = /CLK ;
COUNT1.CLK = /(CLK * COUNT0 ) ;
COUNT2.CLK = /(CLK * COUNT0 * COUNT1 ) ;
COUNT3.CLK = /(CLK * COUNT0 * COUNT1 * COUNT2 ) ;
COUNT4.CLK = /(CLK * COUNT0 * COUNT1 * COUNT2 * COUNT3 ) ;

      " === HORIZONTAL EVENTS === "
CNT08 = COUNT[4..1] == 2H ;
CNT24 = COUNT[4..1] == 6H ;
CNT48 = COUNT[4..1] == CH ;
CNT60 = COUNT[4..1] == FH ;
HBLANK = HQ0 + HQ1 ;      " horizontal blanking (& sync) "
HCLAMP = HQ0 * HQ1 ;     " 'burst key' for sandcastle "
HSYNC = HQ1 ;

      " === CONTROL & OUT === "
VSLONG = VSL ;
CBLANK = VSLONG + HBLANK ;
VSYNCM = POLV * VSLONG ;
        + /POLV * /VSLONG ;
HSYNCM = POLH * ( HSYNC + COSY * VSENC ) ;
        + /POLH * / ( HSYNC + COSY * VSENC ) ;

@INPUT VECTORS
[ HSENC, CNT08, CNT24, CNT48, CNT60 ]
SYNC = 1 - - - 1 B;
C08 = - 1 - - - B;
C24 = - - 1 - - B;
C48 = - - - 1 - B;
C60 = - - - - 1 B;
HOLD = 0 - - - 1 B;

@OUTPUT VECTORS
[ CNTRST, CNTHLD ]
RESTART = 1 0 B;
STOP = 0 1 B;
GO = 0 0 B;

@STATE VECTORS
[ HQ1, HQ0 ]
IDLE = 0 0 B;
BLK1 = 0 1 B;
CLAMP = 1 1 B;
BLK2 = 1 0 B;

@TRANSITIONS
WHILE [IDLE]
  IF [C60] WITH [STOP] THEN [IDLE]
  IF [HOLD] WITH [STOP] THEN [IDLE]
  IF [SYNC] WITH [GO] THEN [BLK1]
WHILE [BLK1]
  IF [C60] WITH [RESTART] THEN [BLK1]
  IF [C48] THEN [CLAMP]
WHILE [CLAMP]
  IF [C60] WITH [RESTART] THEN [CLAMP]
  IF [C24] THEN [BLK2]
WHILE [BLK2]
  IF [C60] WITH [RESTART] THEN [BLK2]
  IF [C08] THEN [IDLE]

```

## Crystal specifications

---

The Philips line of digital decoders requires crystals which meet specific specifications. Picking a crystal vendor solely on the basis of frequency will not guarantee satisfactory performance.

Operational failures that could be related to crystal dysfunction are:

1. Inability to achieve line lock (horizontal lock)
2. Inability to achieve chroma lock
3. Slowness of lock acquisition.

The crystal specifications are:

Nominal frequency:	26.800000MHz (square pixel decoders) 24.576000MHz (CCIR decoders)
Load capacitance $C_L$ :	8pf
Adjustment tolerance:	$\pm 40$ ppm
Resonance resistance $R_r$ :	50 $\Omega$ (square pixel) 60 $\Omega$ (CCIR)
Drive level dependency:	80 $\Omega$
Motional capacitance $C_1$ :	1.1 fF (square pixel) 1.0 fF (CCIR)
Parallel capacitance $C_0$ :	3.5 pF (square pixel) 3.3 pF (CCIR)
Temperature range $T_0$ :	0 to 70 °Celsius
Frequency stability:	$\pm 20$ ppm

The Philips part numbers for these crystals are:

- 9922 520 30004 for the square pixel systems (26.800000MHz)
- 9922 520 30009 for the CCIR system (24.576000MHz)

The Philips crystals can be obtained from:

Philips Components Passive Group, phone: (803) 772-2500

The crystals are also available from Ecliptek. Their part numbers are:

ECX-2194-26.800MHz                      and  
ECX-2097-24.576MHz

Ecliptek can be reached at (714) 433-1200. The contact sales representative is Rodney Mills.

## TDA8708 black level and gain modulation circuit

*Author: Herb Knies*

The Philips TDA8708 8-bit A/D converter digitizes video signals and contains black level and automatic gain control circuits. The binary levels for sync and black are internally fixed in the device. Sync tip is maintained at 00H and black level is maintained at 40H. It may be desirable to allow manual override of these automatic features. The following circuit describes a method for overriding the automatic features of the TDA8708 as well as retaining them.

### MANUAL GAIN CONTROL

Normal operation and connections of the TDA8708 are shown on page 2 of the schematic when it is used in conjunction with the Philips SAA71XX series Digital Video Decoders. The only changes to the normal circuit are made through connections labeled "Black" and "Gain." Normally, a capacitor is connected to ground at Pin 25 of the data converter. This capacitor holds a charge dependent on the level of the input video signal and the control voltage necessary at Pin 25 to maintain sync level of 00H. Currents near 50-100 microamps are generated within the converter during horizontal blanking times to charge or discharge the capacitor as necessary, in order to maintain the preset binary output levels of the converter. The voltage on Pin 25 controls the gain of the input amplifier of the converter.

A similar circuit and current source is implemented on Pin 24. However, its only function is to provide the proper DC offset voltage necessary to maintain the black level at 40H regardless of changes of input signals or bias changes on input pins 16, 17, or 18.

Under normal operation, the data converter binary outputs are maintained at precise digital values.

Page 1 of the application schematic shows that the gain connection to Pin 5 of the TDA8708 is connected to capacitor C1 via an analog switch at U2. During horizontal blanking time the analog switch maintains a connection from Pin 25 of the converter to capacitor. Thus, sync levels are maintained via the automatic circuits in the converter. However, if necessary, the control voltage on Pin 25 can be switched to the input voltage at Pin 12 of analog U2 switch during the active video time of each scan line. DAC7 of U1 and bias resistors R1, R2, and R3 provide a variable control voltage for manual portion of gain only during the active video portion of the scan line.

The bandwidth of the control voltage on Pin 25 of the converter can be as high as 5 Mhz so that a precise match of the timing of the gain change is possible at the beginning and ending of blanking times. Noise on the gain control pin must be kept to a minimum in order to avoid AM modulation of the input video signal. The digital decoder can be reprogrammed to adjust the timing of the HCL and HSY timing signals to carefully match the timing diagram of page 1 of the schematic. Refer to the TDA8708 data sheet for a discussion of the operation of these signals in the TDA8708. Do not worry that the modified positions of the HSY and HCL signals might affect the operation of the converter. They will not because the change in position is small compared to the overall width of the pulses. For optimum performance, the beginning and ending of the

gate signal at Pins 5 and 6 of U3 should be set within the minimum blanking time of any signal being digitized.

### BLACK LEVEL CONTROL

Analog switch U2 provides another function besides control of the gain voltage at Pin 25 of the TDA8708 converter. It can be switched to inject a DC pulse on Pin 4 to R15 at Pin 19 of the data converter. Pin 19 is the video output of the input amplifier of the TDA8708. It is nominally about 1V PP. If a DC pulse is added to the video signal at R15 during active video time, the DC level between blanking and active video can be modified. The data converter still provides a constant black level of 40H during blanking time but the data converter can produce other levels for black during active video depending on the polarity and level of the injected signal. DAC6 and bias resistors R6, R4, and R5 provide a variable bias at Pin 5 of U2, which is gated onto the video signal by gate pulse at Pin 3 of U5.

It is desirable to inhibit the modulation of black and gain signals during the vertical sync area so that proper integration of the vertical sync will be maintained by processing circuits. This is accomplished by VSYNC INHIBIT at Pin 11 of U5. Additional control functions are provided by logic levels of DAC5 and DAC4, which turn on and off the black level and gain modification signals at U2. It should be noted that different bias resistors can be selected on DAC7 and DAC6 pins to affect the allowable range of control but the DAC full range of 00H to 3FH should be used in order to give the finest degree of control.



# TDA8708 black level and gain modulation circuit

## TDA8708 BLACK LEVEL AND GAIN MODULATOR

(BRIGHTNESS AND CONTRAST)

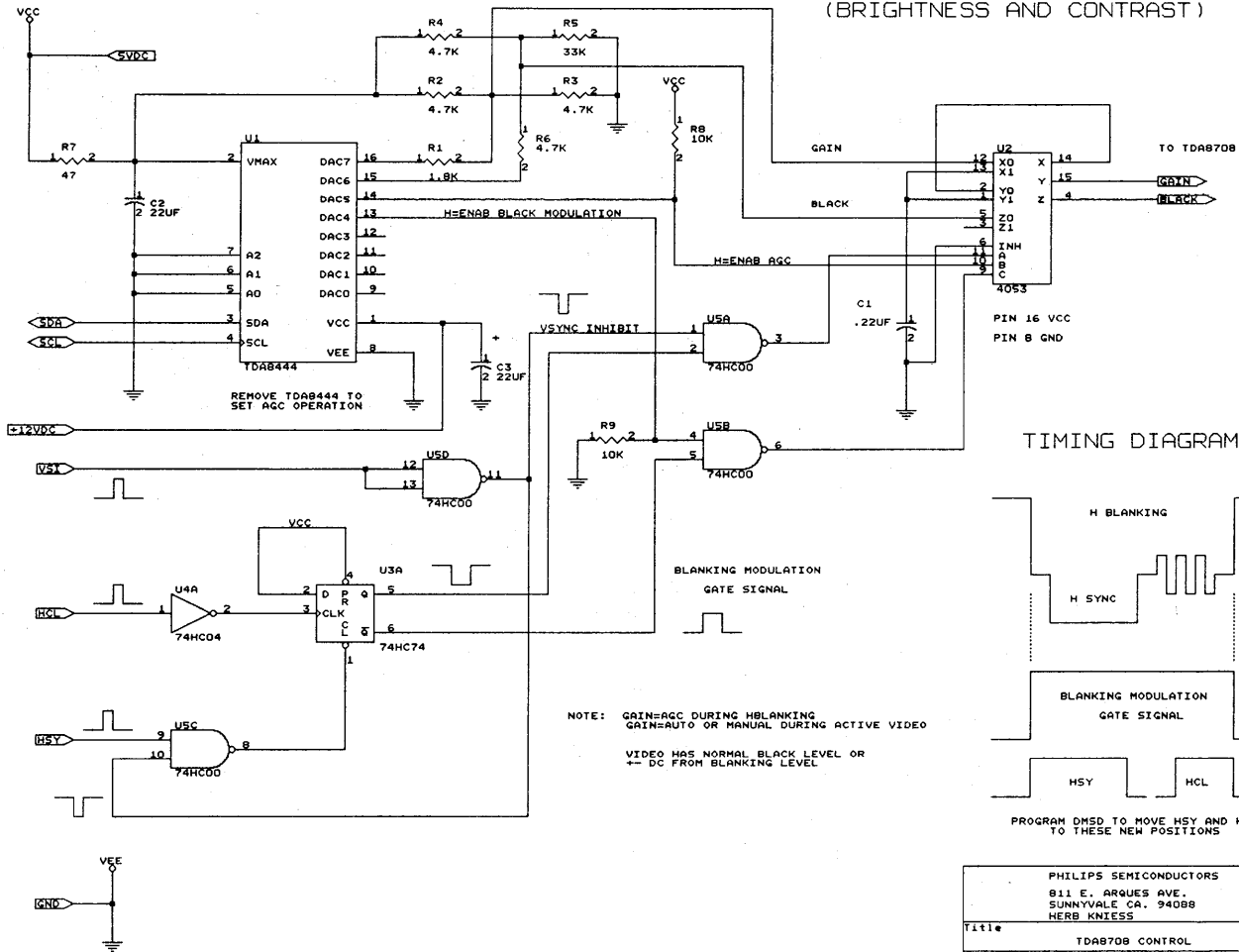

PHILIPS SEMICONDUCTORS 811 E. ARQUES AVE. SUNNYVALE CA. 94088 HERB KNISS		
Title	TDA8708 CONTROL	
Size	Document Number	REV
E	CONTROL.SCH	B
Date:	February 3, 1993	Sheet 1 of 2

# TDA8708 black level and gain modulation circuit

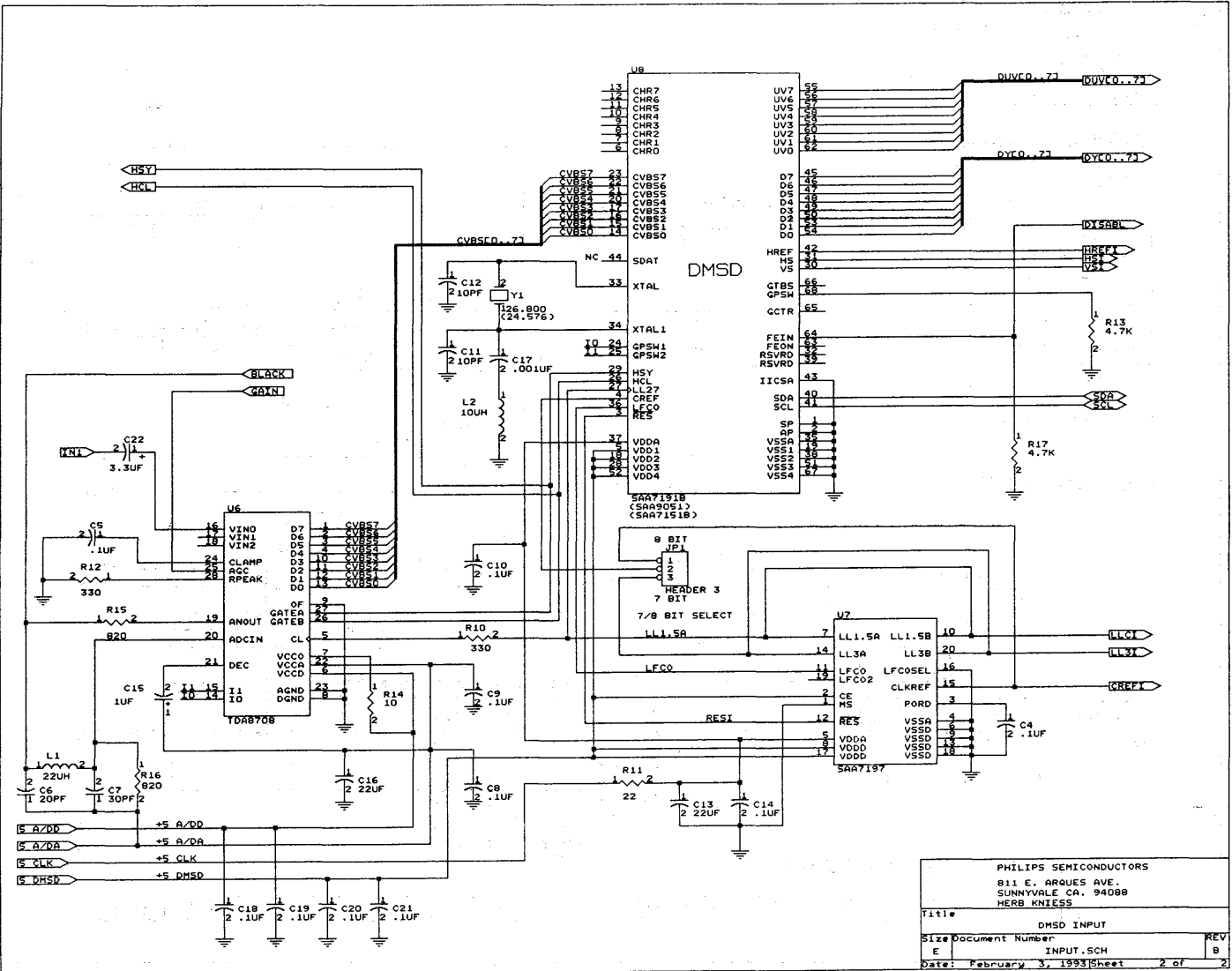

PHILIPS SEMICONDUCTORS 811 E. ARGUES AVE. SUNNYVALE CA. 94088 HERB KNISS		
Title	DMSD INPUT	
Size	Document Number	REV
E	INPUT.SCH	3
Date:	February 3, 1993	Sheet 2 of 3

# TDA9141 analog decoder application

Author: George Ellis

## OVERVIEW

Analog solutions for video decoding and digitization are available in addition to the digital methods mentioned elsewhere in this book. The individual components are generally of lower cost; however, trade-offs with regard to the total number of components to perform a specific function must be considered.

## SYSTEM CONFIGURATION

This application is divided into four blocks:

1. Analog video to analog YUV decoding
2. A/D converter with clock and support circuitry
3. Level control circuit for block 2
4. Optional RGB output block

Various elements of this application need not be used if not called for by the application. The intent here is to demonstrate a full featured solution.

## DECODER

Composite, S-video, or analog RGB can be input to the Philips TDA9141 multi-standard decoder. This device, in conjunction with the TDA4661 delay line, will decode the NTSC, Pal and Secam standards, and output them as analog Y (luma) and UV (chroma) outputs. The luma-to-chroma delay is matched; therefore, no luminance delay line is necessary. If NTSC is desired exclusively, the TDA4661 delay line need not be used.

The delay line is used as a chroma comb filter for NTSC, and although not strictly required, it does reduce undesirable cross-color effects. Note that unlike older delay lines that work in the subcarrier base-band, the TDA4661 works in the demodulated UV color-difference band, and is implemented with charged-coupled technology instead of using a bulky glass delay line.

Optional color transient improvement and peaking can be applied to the YUV signal by use of the TDA4670; again, this may be deleted in a no-frills application.

Two comparators are used to extract horizontal blanking and clamp signals from the sandcastle pulse generated by the TDA9141, and are used for the A/D converters. The TDA9141 also outputs a line-locked 6.75MHz clock that is used in the conversion process.

The decoder and color transient device are controlled via the IIC two-line interface bus. The decoder can be programmed for automatic detection of the three video standards.

## A/D CONVERSION AND CLOCK

The analog Y, U, and V signals are applied as AC coupled inputs to three TDA8709 A/D converters. Gain controls for all three converters and a black level control for the Y converter are provided by the level control block.

The Clamp Select pin (pin 27) is set to adjust the DC level of the U and V converters to a value corresponding to decimal value 128 during the application of the positive clamp pulse derived from the decoder block. The Clamp Select pin of the Y converter is set to force the DC input level to correspond to a value of decimal 16. This sets the converters to the appropriate digital value during blanking.

Each converter is capable of selecting one of three inputs applied, and a simple low-pass filter is inserted between the selected signal and the A/D input to remove any possible high frequency noise that could cause aliasing effects.

The 6.75MHz clock from the TDA9141 is a low level sawtooth with an amplitude of about 1 Vpp. This signal is very similar to the LFEO signal available from the digital chip decoders, thereby making it possible to generate 13.5MHz, 27MHz, and CREF signals using the same device as that used by the digital chip set, the SAA7197.

The UV bandwidth is one half the 13.5MHz luma bandwidth, therefore, the 13.5MHz clock is divided by two. The 13.5MHz signal and the CREF signal are delayed to match the delay introduced in producing the 6.75 clock.

The 6.75 clock is used for the conversion process of the U and V converters and for the multiplexers that follow. This results in one UV pair for every two luminance samples. The outputs of the multiplexers and the luma A/D converter are latched with D flip-flops using the 13.5 clock.

The resulting digital format is the 16 bit 4:2:2 format used by various digital systems, including the Philips video scaler (SAA7186) and encoder (SAA7199B). This is also an efficient storage mode for video as it uses 16 bit wide memory structures instead of 24.

A new triple input YUV A/D converter has been added to the Philips line, the TDA8758, which outputs the 4:2:2 format; however, it will not be available until the end of 1993, and therefore has not been included in the handbook.

## LEVEL CONTROL

An IIC controllable level control circuit is achieved using a TDA8444 6-bit octal DAC to produce DC control of the gain control inputs of the data converters. A fourth DAC output is gated to be applied only during blanking, and is added to the Y input signal to produce a DC offset of the luma signal, thus allowing control over the black level. These DC levels could as easily be derived from resistors instead of the DAC, for use in systems that have these parameters preset at the factory.

## RGB OUTPUT AND YUV BUFFER STAGE

If YUV to RGB conversion is necessary for output to a monitor or for RGB digitizing, the TDA4686 is useful. This device has a YUV to RGB analog matrix with two additional RGB inputs that can be switched in at a pixel-by-pixel rate.

The circuit shown here will drive an analog RGB monitor with 75  $\Omega$  loading. It may also be used to drive the inputs of three RGB digitizing A/D converters (same circuit as the Y converter, times three). Because the TDA4686 has brightness, contrast, and saturation controls via IIC bus, the input circuit previously described would not be necessary, as all gain and black level adjustments can be made with the TDA4686.

If YUV analog component video output is desired, the YUV levels that are input to the TDA4686 can be buffered by high speed op amps to drive 75  $\Omega$  loads. For component video, the output levels are set to .7 Vpp for full scale U, V, and non-composite Y (Y without sync) driven into 75  $\Omega$ . A series resistor is needed to match the cable impedance and the driven device would have a 75  $\Omega$  termination load. This requires that the gain of the op amps be set such that full scale output is 1.4 Vpp before the series matching resistor.

## SUMMARY

Full featured desktop video solutions can generally be met with far fewer parts if a digital chip set is used. This is due to the fact that these digital solutions were designed for this market, where the analog methods were originally designed for consumer (TV) applications where there is no requirement for digitization and data format. There are, however, many low end applications where various portions of this application could be useful.



TDA9141 analog decoder application

8709A BLACK LEVEL AND GAIN CONTROL  
(BRIGHTNESS AND CONTRAST)

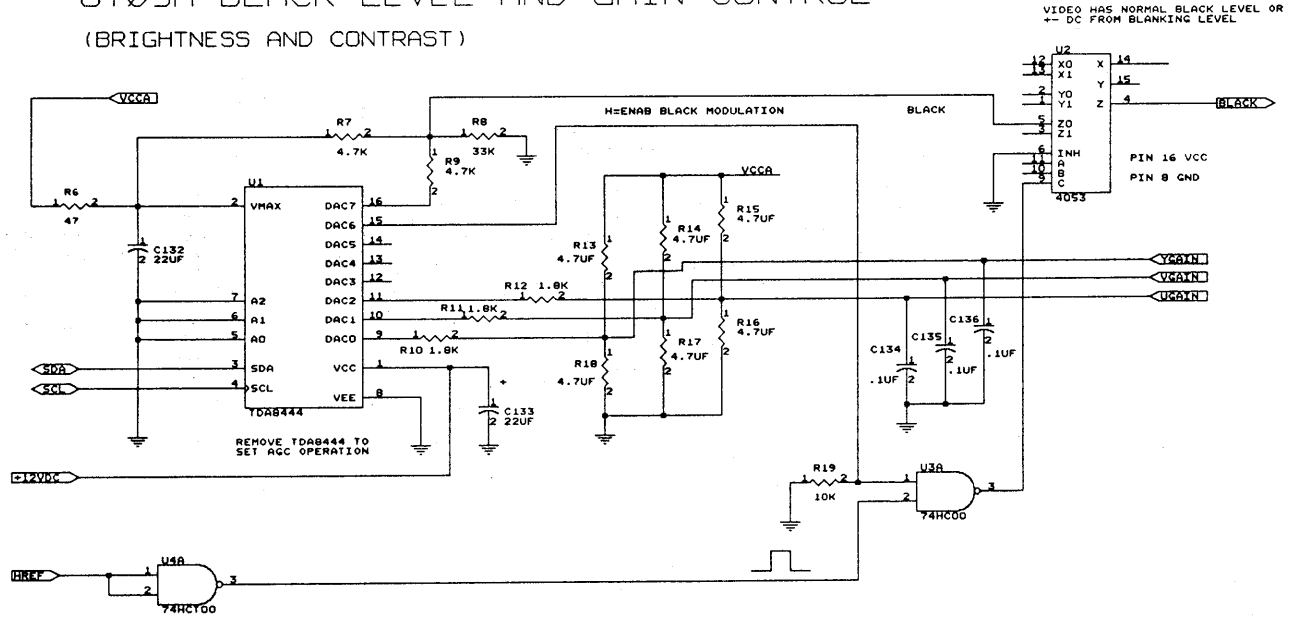

TIMING DIAGRAM

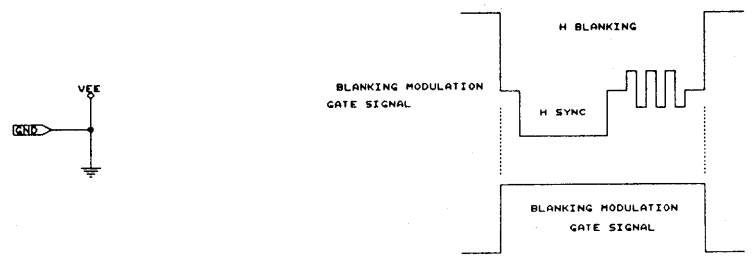

PHILIPS SEMICONDUCTORS 811 E. ARGUES AVE. SUNNYVALE CA. 94088	
Title	CONTROL.SCH
Size Document Number	REV
E	B
Date:	March 9, 1993 Sheet 2 of 5

# TDA9141 analog decoder application

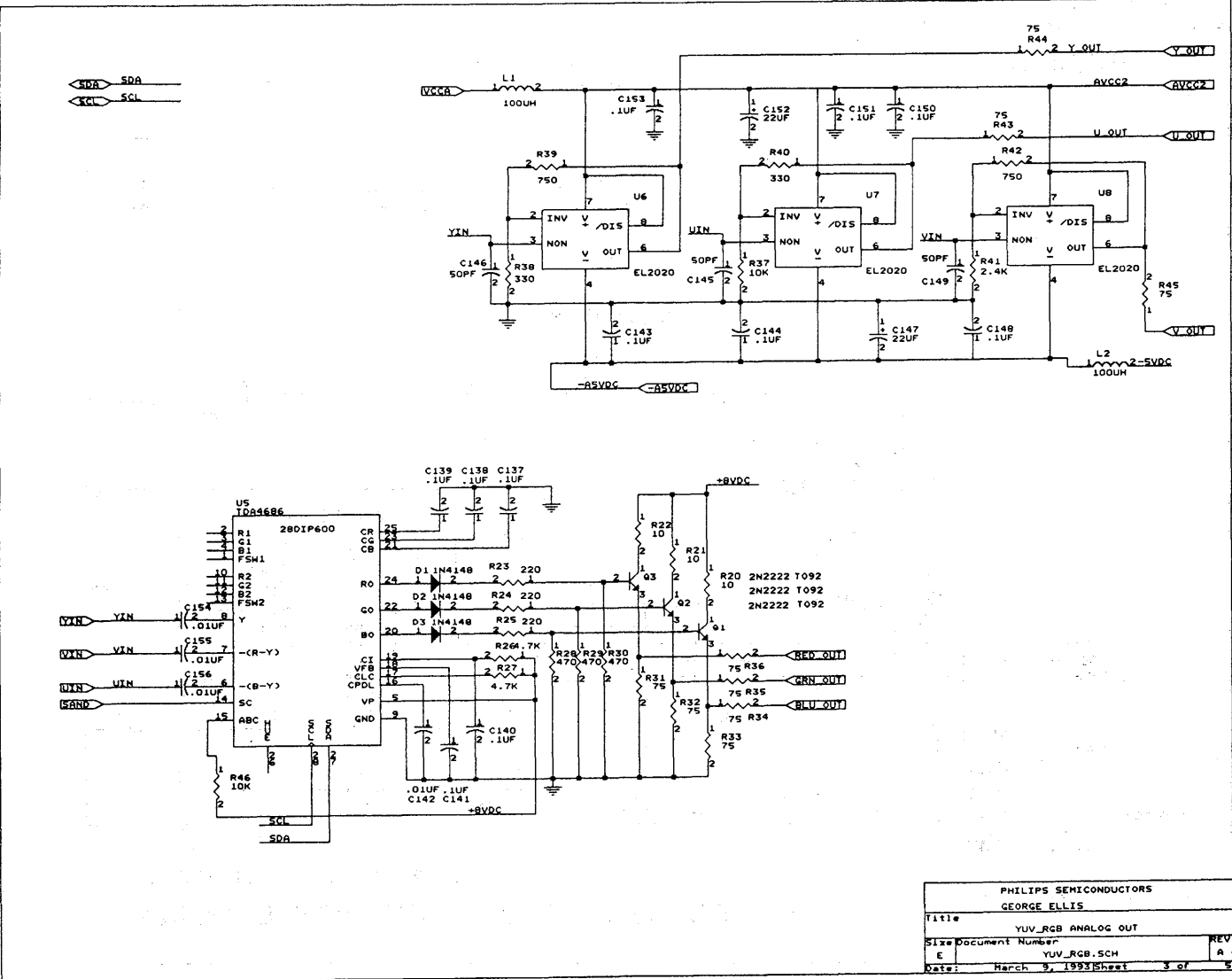

PHILIPS SEMICONDUCTORS		
GEORGE ELLIS		
Title#	YUV_RGB ANALOG OUT	
Size	Document Number	REV
E	YUV_RGB_SCH	A
Date:	March 9, 1993	Sheet 3 of 5

# TDA9141 analog decoder application

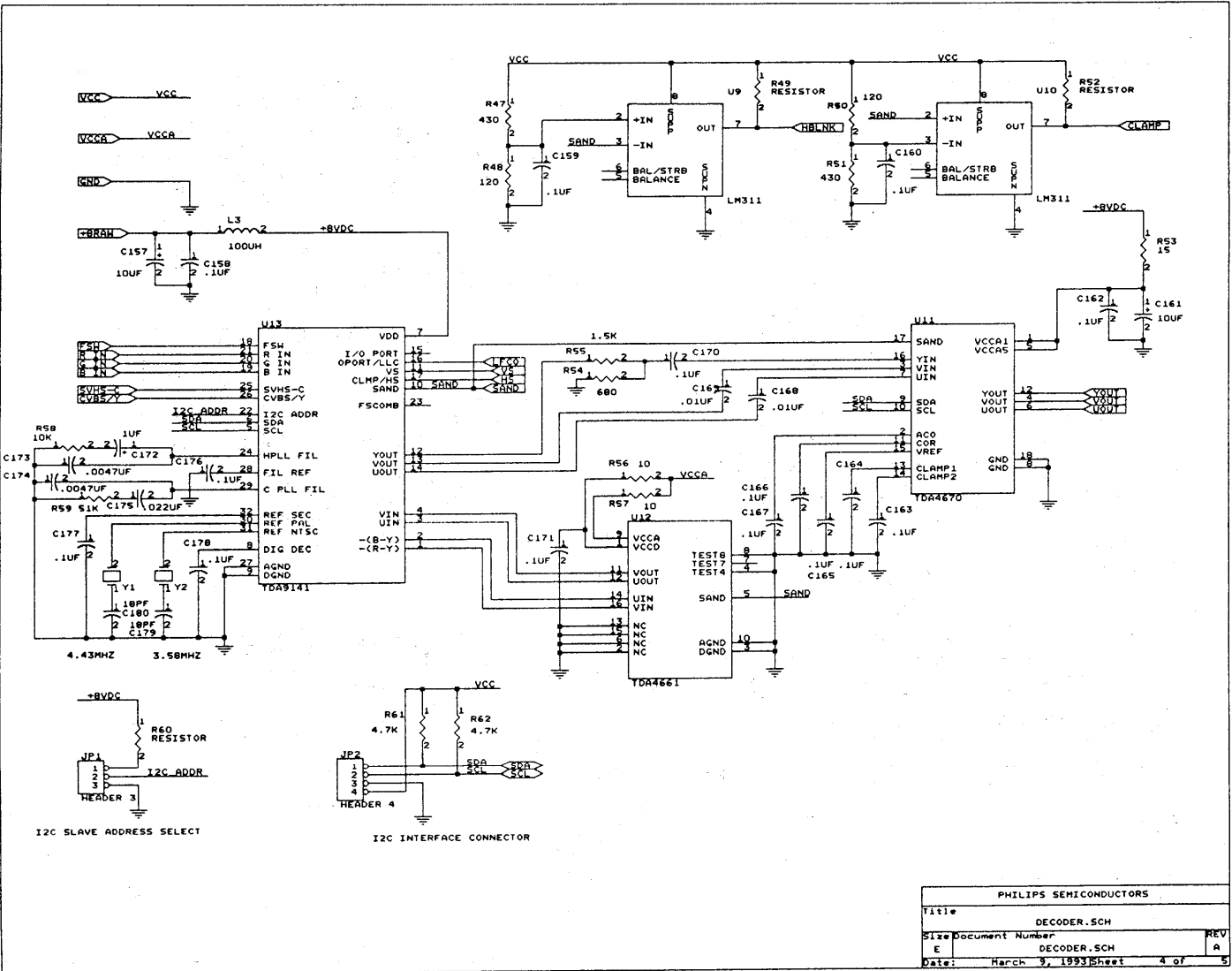

# TDA9141 analog decoder application

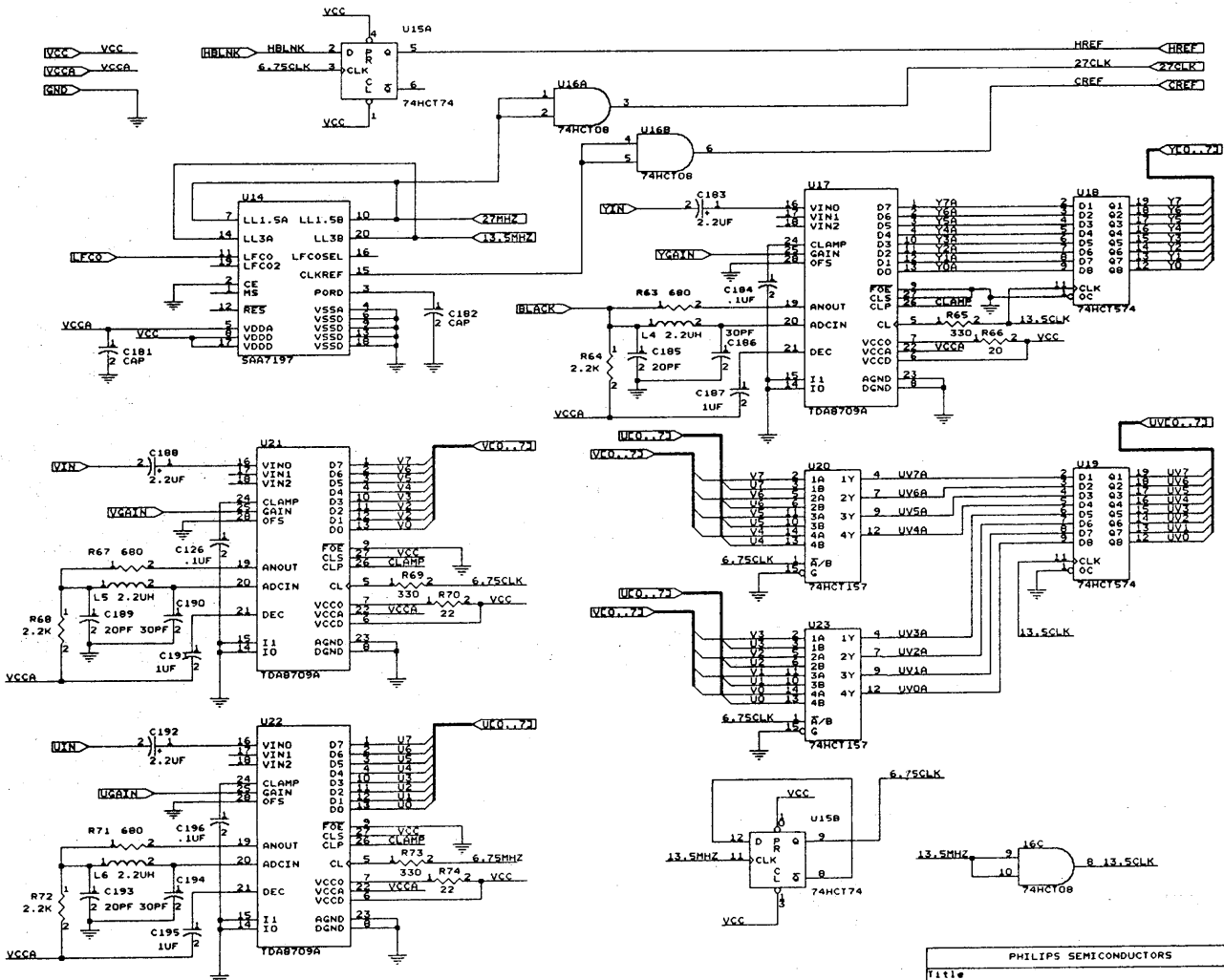

PHILIPS SEMICONDUCTORS		
Title	ADC.SCH	
Size	Document Number	REV
E	ADC.SCH	A
Date:	March 11, 1993	Sheet 5 of 5



# Digital video evaluation board

Author: George Ellis

## OVERVIEW

In order to individually evaluate the Philips digital video encoding and video DAC systems, the SAA7199B and SAA7165 (SAA9065) chips, respectively, a demo board was developed that is capable of receiving digital data from a broadcast quality video test generator.

This board receives input in the D1 digital video format, converts the data to the 16 bit 422 data format used by the Philips system, and produces the clocks and sync signals necessary to drive the encoder and video DAC. The board generates analog composite video and S-video using the SAA7199B digital encoder, and it produces analog YUV (Y, Cb, Cr) using the SAA7165. It also converts the analog YUV into analog RGB using the TDA4686, thus demonstrating a complete digital-to-analog video output solution.

## D1 DIGITAL VIDEO FORMAT

D1 digital video (parallel mode) is an industry standard used to transfer video without any loss of quality. Being digital in nature, this signal can be duplicated indefinitely, and therefore is used in many broadcast production facilities.

D1 is transferred as a nine-pair (8 bit D1) or as an eleven-pair (10 bit D1) ECL cable configuration; the 8 bit D1 format is used for this demo board.

Upon input to the demo board, these signals are converted to TTL levels consisting of 8 data bits and one 27MHz clock stream.

The luminance (Y) and chrominance (Cb, Cr) are multiplexed onto the 8 bit data path in the order: Cb, Y, Cr, Y, etc. (see Figure 1). For each two clock cycles, one luminance and one of the two chrominance signals are transmitted. This is the same luminance and chrominance data bandwidth used by the Philips chip set, with the exception that it is multiplexed.

De-multiplexing the luma and chroma data produces 8 bit data paths each for luminance and chrominance, clocked at a 13.5 MHz clock rate. There is now one luma byte delivered for each 13.5MHz clock and one pair of chroma axis bytes for every two clock intervals; this is exactly the data format required by the digital chip set.

The D1 format also inserts markers into the data path that define the beginning and end of active video. These markers consist of 4 hex bytes: FF, 00, 00, XY. The series, FF 00 00 is used to initiate the start or end of active video and to latch the XY byte information.

The XY byte contains three bits that define the following (see Figure 2):

- End or Start of Horizontal Blanking
- End or Start of Vertical Blanking
- Field 1 or Field 2 Status.

Although horizontal and vertical sync are not included in these codes, their relation to the blanking signals is known, and they can be reconstructed.

## BOARD DESCRIPTION

Reference to sheet one of the schematic shows that the demo board consists of four subsections:

- ECL translation and power regulation
- D1 to 422 demultiplexing
- Digital YUV to analog composite encoding
- Digital YUV to analog YUV and analog RGB conversion.

## ECL Translation

Sheet two shows the D1 signal input at connector P1 as eight pairs of data and one pair of clock lines. These lines are terminated through 470  $\Omega$  resistors to -5 VDC and are converted from differential ECL data into ground referenced TTL data (U32-U34).

Standard three terminal regulators are used to convert unregulated positive and negative 9 volt inputs to regulated positive 5 VDC (Vcc), negative 5 VDC and positive 8 VDC. Bypass caps are shown and are distributed throughout the board.

U51 is a programmable microcontroller that will initialize the appropriate devices upon power up by use of the Philips I<sup>2</sup>C interface. I<sup>2</sup>C programming can also be performed over the I<sup>2</sup>C bus via external connectors (JP4 and JP5 shown on sheet 5).

## D1 to 422 Demux

The 8 data lines enter buffer U31 on sheet 3 and are clocked sequentially through U12, U13, and U14 at a 27 MHz clock rate. If a byte value of FF is detected at U26 at the output of U14, and if data byte values of 00 are detected by U5A and U5B at the outputs of U13 and U12, the coincidence of these signals latches the contents of bits TL6, TL5, and TL4 into U15. These signals are reclocked at a 13.5 MHz rate and are output by U17 and U6B as HREF (horizontal blanking), vertical blanking, and field ID.

The 27 MHz clock is divided in half by U27A and buffered by U7. Counters U8 and U9 are loaded to a preset by HREF and clocked by the 27 MHz clock to produce a horizontal sync reset pulse at the output of U22A.

The 8 bits of multiplexed YUV data are duplicated into two identical buses. One bus (to be demuxed as Y) is connected to the A1-D1 inputs of U20 and U18, the other bus (to be demuxed as UV) is connected to the A2-D2 inputs of U19 and U21. The outputs of all four of the demux devices are returned to the alternate inputs of the same device, QA-QD of U20 and U18 are returned to the corresponding A2-D2 inputs, and QA-QD of U19 and U21 are returned to the corresponding A1-D1 inputs. All four devices are clocked at the same 27 MHz rate, and the WS (write strobe) is supplied with a common 13 MHz clock. Due to the reversal of the input arrangement, the write strobe in one case will latch the Y data, and in the other case will latch the UV data. The data output from U18-U21 actually changes at a 13.5 MHz rate due to the feedback of the data and the 13.5 MHz write strobe. This data is latched and buffered by U24 for Y and U23 for UV. These two devices can also be tristated in the case it is desired to input alternative data from connector JP1. This tristate is controlled by jumper JP3.

## Digital YUV to Analog Composite Encoding

The 16 bits of demuxed Y and UV are input to the data ports of the SAA7199 digital encoder. The device is supplied with a 13.5 MHz pixel clock, HREF for blanking, HS for horizontal reset, and Field ID for vertical reset. The TSG422 generator does not output interlaced vertical blanking, the generator produces vertical blanking at the beginning of line 263, as opposed to starting midway between lines 262 and 263, as is the case in analog video. The SAA7199B needs only to be reset vertically once to place it in the proper field sequence; the device will then create the proper vertical synchronization. That being the case, field ID is used to reset the device vertically for the first field, and the SAA7199 calculates and correctly produces the interlaced vertical interval between field 1 and 2.

The signal CLK\_13 is used both to latch the data (via the LDV pin) and, after a delay period produced by U47A and U47B, is applied to the CLKIN and LLC pins. The delay is to ensure that latching the data and clocking it do not occur simultaneously.

The SAA7199B simultaneously outputs composite video and S-video (separate luminance and chrominance). Output filters are applied to these outputs to low pass any residual clock energy and to provide sin(X)/X correction. The output of the composite filter is buffered; this allows for driving long cable lengths without affecting the output filter characteristics.

## Digital video evaluation board

U54, Q4, and Q5 strip and buffer sync from the luminance portion of the S-video output. This composite sync is used for the analog YUV and RGB that is produced by the SAA7165 and TDA4686 devices (described in the next section). The position of this sync relative to the active YUV (RGB) signals is programmable via the SAA7199B.

The SAA7199B is programmed to run in slave mode with YUV as the input format. The following chart lists the complete register settings for initializing the encoder:

SUB ADDR	DATA
<b>SAA7199B</b>	
00	AE
01	00
02	00
03	00
04	44
05	30
06	52
07	30
08	10
09	00
0A	00
0B	00
0C	A6
0D	00
0E	0D

These registers are programmed via the I<sup>2</sup>C bus, either by the microcontroller or the I<sup>2</sup>C interface connectors JP4 or JP5.

Note that the encoder has both digital (Vcc) and analog (AVcc) power connections. AVcc is produced from Vcc by the filter network comprised of L4, C64, C65, and C67.

### Digital YUV to Analog YUV and RGB conversion

Sheet five indicates the data buses Y[0..7] and UV[0..7] input to U53 in parallel with the outputs of U38 and U38 tristate buffers.

These buffers, in conjunction with U23 and U24 (sheet 3) and the signal D1SEL set by jumper JP3, select the input to the SAA7165 (and the SAA7199B) to be either the

demuxed D1 data (JP3 shorted) or the data input from connector JP1 (JP3 open). An example of data that could be input to the demo board at JP1 is the data stream from the Philips digital decoder (SAA7151B, SAA7191B, or SAA7194(6)). The sync and clock signals from the decoder are input at connector JP2.

Connectors JP2 and JP1 are oriented such that the D1 demo board may be connected directly above the Philips DTV7199 demo board. JP2 connects to JP10 of the DTV7199 and JP1 connects to JP14 of the DTV7199. The same mechanical relation exists between the pair of connectors.

The SAA7165 also receives the 13.5 MHz clock and HREF signals to clock and blank the conversion process.

The video DAC outputs analog Y, U, and V on separate outputs. The polarity of the U and V signals is controllable in software for flexibility with all systems. The SAA7165 also provides controllable color transient improvement. The analog YUV signals are buffered by U42-U44 to provide .7 Vpp signals (full scale video) into a 75 Ω terminated load.

As with the SAA7199B, the SAA7165 has both digital (Vcc) and analog (Vcc\_ANA). This separation is effected by L2, C22, and C23.

The YUV outputs are also fed to the inputs of the TDA4686 via resistor networks to provide the proper voltage range to the TDA4686. This device requires a full scale Y input of .45 Vpp, U input is 1.33 Vpp full scale, and V is 1.05 Vpp full scale.

The TDA4686 has an analog YUV to RGB matrix with software control of contrast, brightness, and saturation via the I<sup>2</sup>C bus.

The TDA4686 requires a two-level timing signal called 'sandcastle' to initiate certain internal processes. This signal is synthesized by U40A, U45A, U46A, and U45B from vertical sync and HREF. HREF is delayed in this circuit to compensate for the pipeline delay of the video through the SAA7165.

The output of the TDA4686 are fed to a modified emitter follower circuit that ensures the proper DC blanking levels and drives 75 Ω loads. The default register setting

provided by the microcontroller set RGB levels to .7 Vpp (full scale).

The default register settings are:

SUB ADDR	DATA
<b>SAA7165*</b>	
01	04
02	85
03	3B
<b>TDA4686</b>	
00	09
01	30
02	27
03	19
04	1F
05	1F
06	1F
07	1F
08	1F
09	1F
0A	3F
0B	00
0C	80
0D	1A
*There is no sub address 00 for the SAA7165.	

JP4 and JP5 are connected in parallel to allow daisy chaining of the I<sup>2</sup>C cables to facilitate a multiple board configuration. Because the state of the I<sup>2</sup>C bus is not necessarily known upon reset, the I<sup>2</sup>C interface should be disconnected when resetting the board via the microcontroller.

The subaddress settings given are suggested initial values; consult the individual data sheets to manipulate the user-adjustable controls such as contrast, brightness, aperture control, color transient improvement settings, etc.

Performance tests of the SAA7199B using the Tektronix VM700A Video Measurement Test Set were made using the D1 demo Board, and results published in a document titled "SAA7199 Performance Measurements." This document is published as a separate data sheet.



# Digital video evaluation board

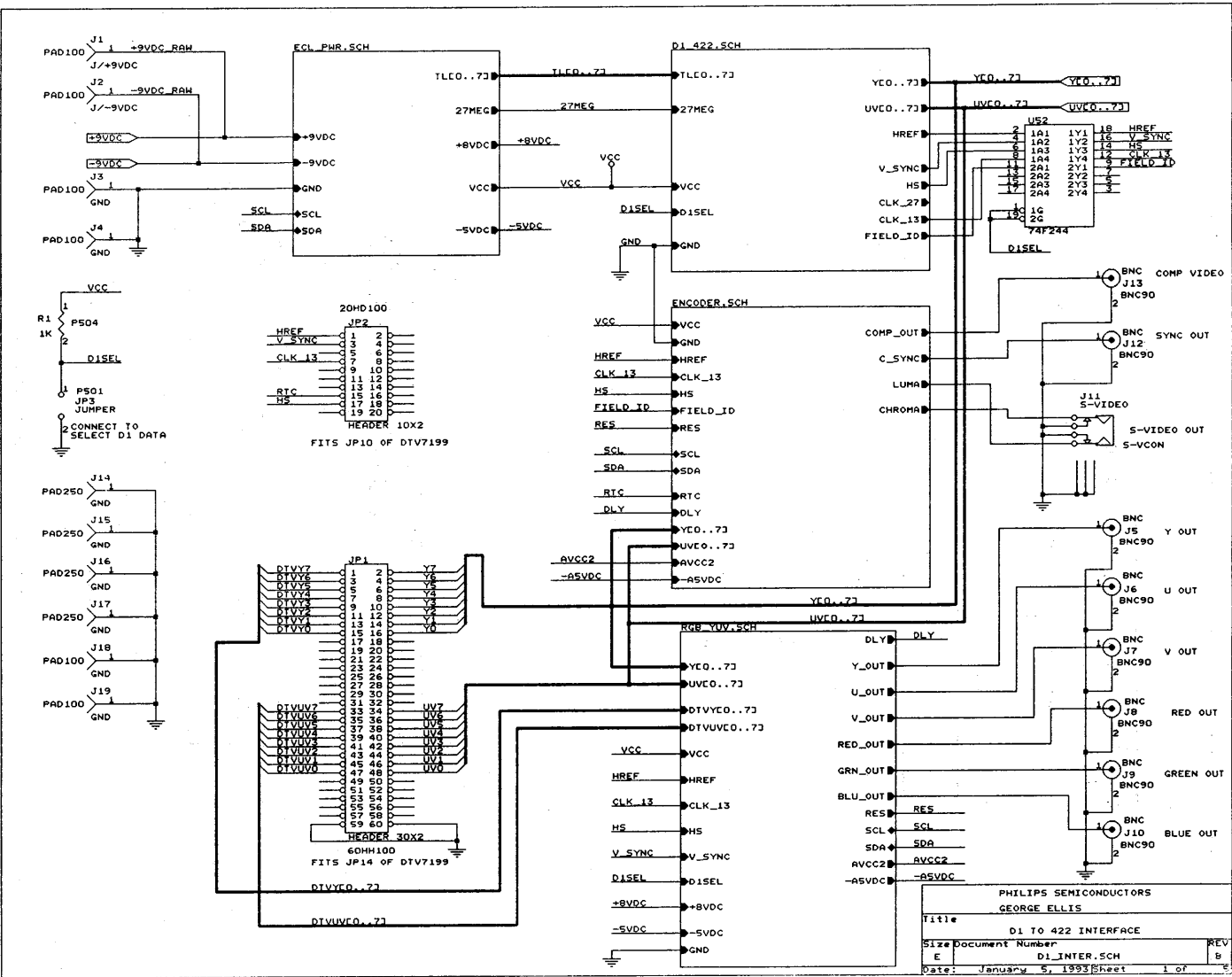

PHILIPS SEMICONDUCTORS	
GEORGE ELLIS	
Title	D1 to 422 INTERFACE
Size Document Number	D1_INTER_SCH
Date	January 5, 1993
Sheet	1 of 5



# Digital video evaluation board

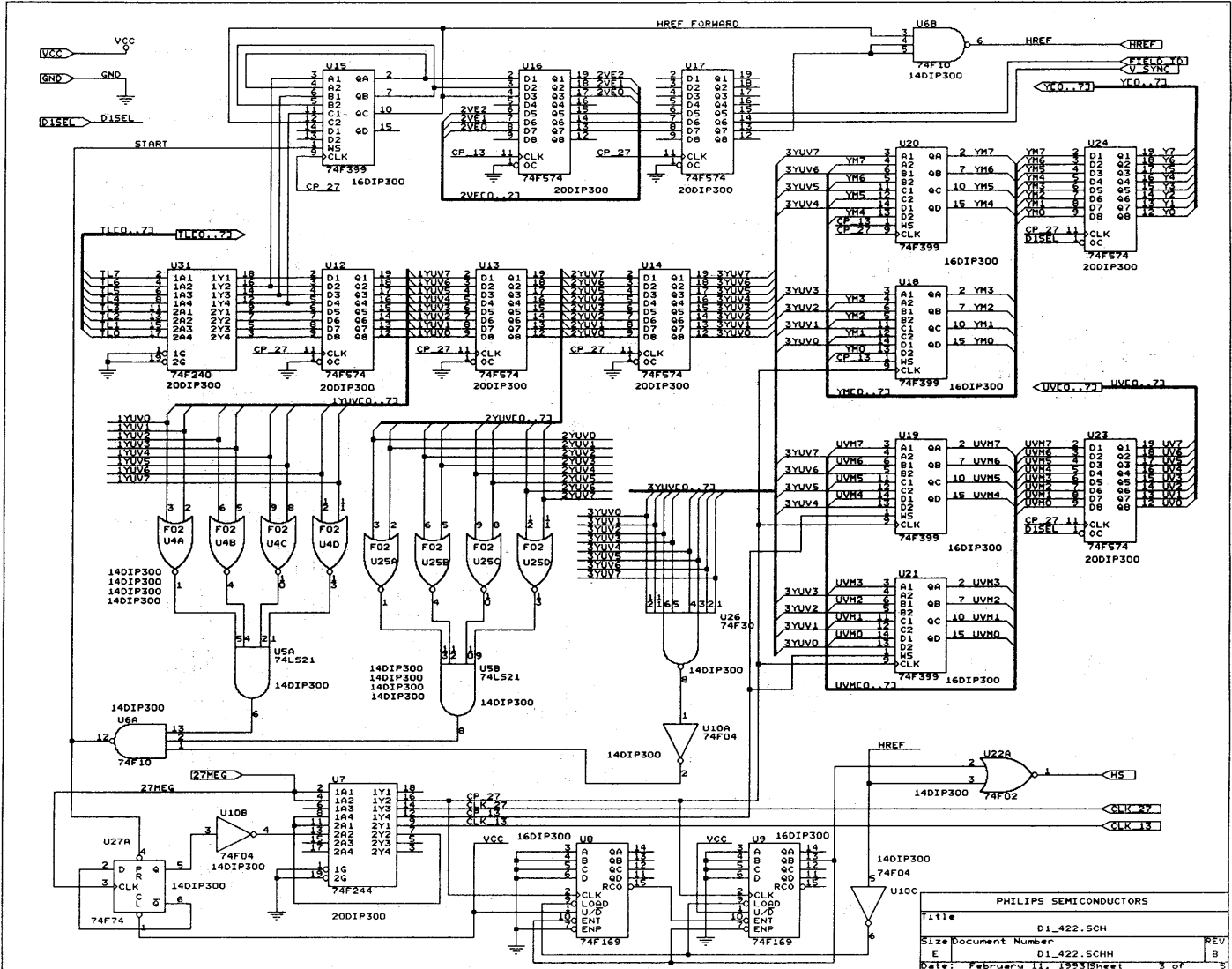

# Digital video evaluation board

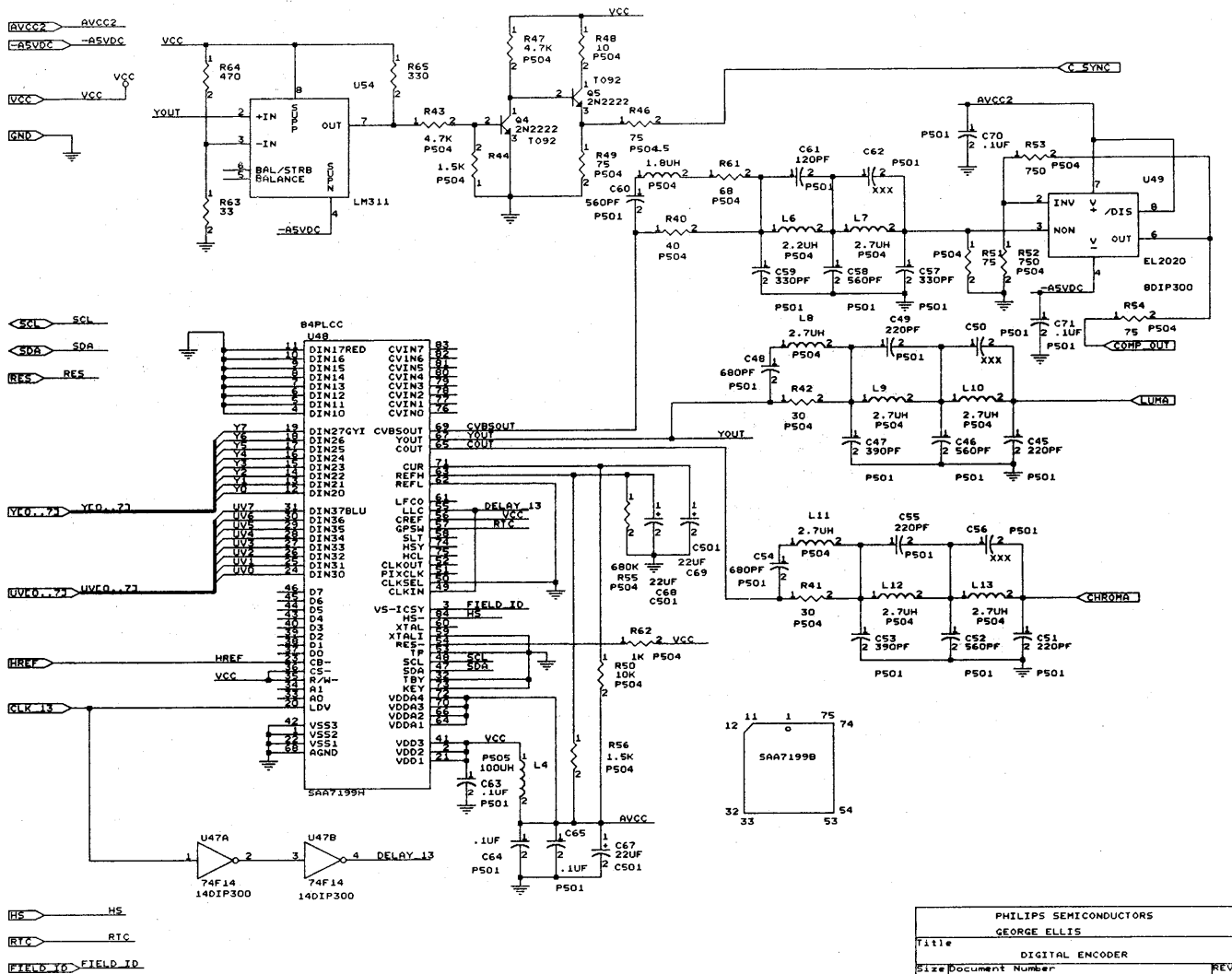

PHILIPS SEMICONDUCTORS		
GEORGE ELLIS		
Title	DIGITAL ENCODER	
Size Document Number	ENCODER.SCH	
E		REV B
Date:	February 11, 1993	Sheet 4 of 5

Digital video evaluation board

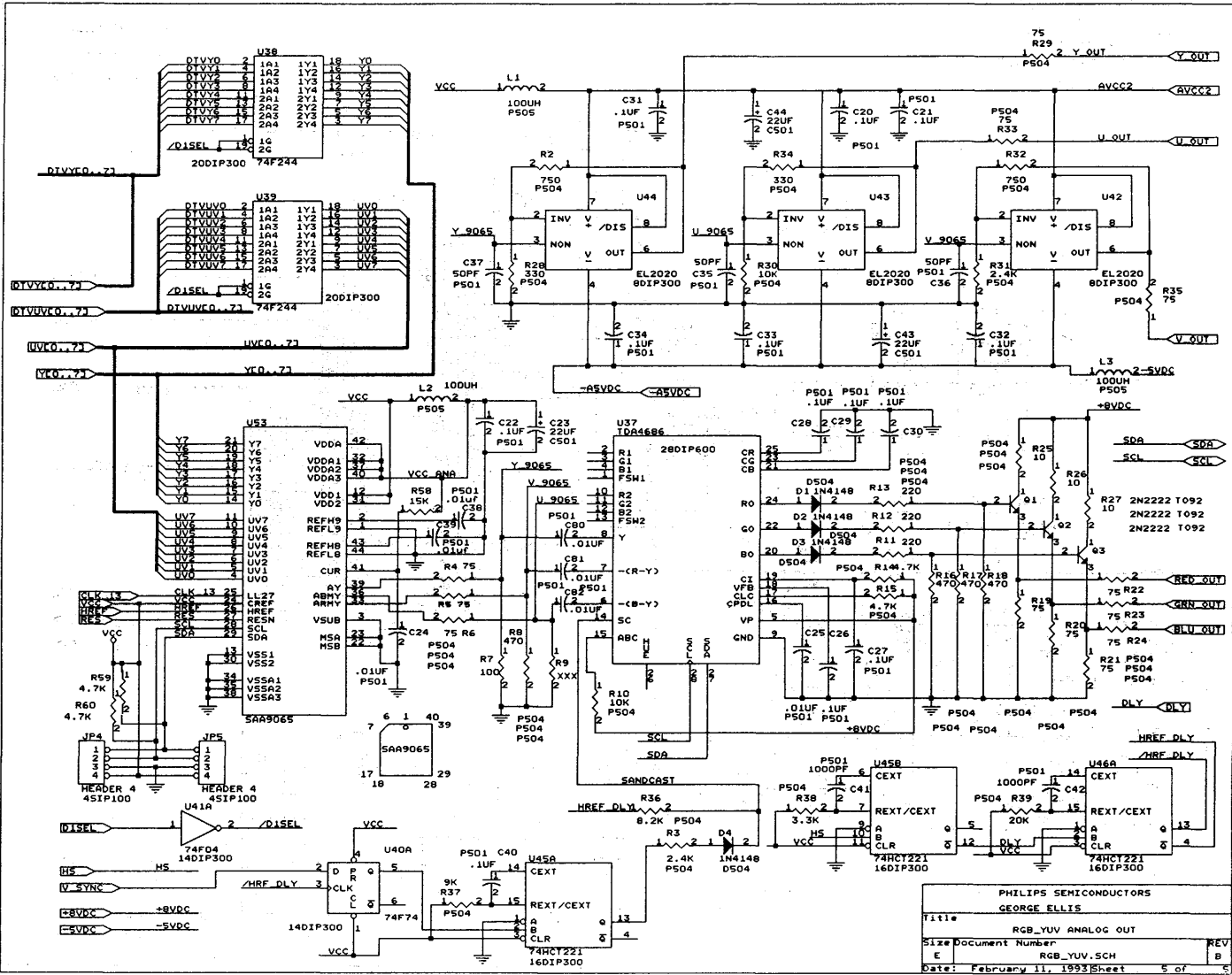

PHILIPS SEMICONDUCTORS		
GEORGE ELLIS		
Title	RGB_YUV ANALOG OUT	
Size	Document Number	REV
E	RGB_YUV.SCH	B
Date:	February 11, 1993	Sheet 5 of 5

April 12, 1993

2-156



## CVBS output filter for SAA7199B encoder

Author: George Ellis

### OVERVIEW

Peak performance of the SAA7199B can be obtained by the use of an output filter connected between the CVBS output of the device and the output connector. This filter provides  $\sin(x)/x$  equalization for the CVBS (composite video) signal.

### THEORY

$\sin(x)/x$  attenuation occurs with all DACs (digital-to-analog convertors) due to the sampling clock. This attenuation increases as the output frequency of the DAC increases and reaches total attenuation when the DAC output is equal to the sample frequency (see Figure 1.)

Another result of clocking the DAC is the creation of energy which is centered at multiples of the sample frequency  $f_s$  and has a bandwidth of  $2(f_s - f_v)$ , where  $f_v$  is the highest frequency of the output signal (see Figure 2). This non-baseband energy is referred to as 'aliasing', and if  $f_s$  is less than twice the frequency of  $f_v$ , this aliasing will extend into the baseband signal. This is not desirable because it produces visible corruption of the video signal.

The requirements of the filter, therefore, are that 1) it provides sufficient attenuation at frequencies above  $f_v$  and 2) it applies the appropriate inverse  $\sin(x)/x$  boost at frequencies below  $f_v$ . Figure 3 shows an example of this filter requirement as a graph of gain versus frequency.

### THE FILTER

The filter is illustrated in Figure 4. It is a modified low pass filter with components added to provide  $\sin(x)/x$  equalization (C1, L1, and R2).  $\sin(x)/x$  attenuation is calculated by the formula

$$A(x) = \frac{\sin(\pi f_x / f_s)}{\pi f_x / f_s}$$

where  $f_x$  is the frequency in question. The number  $\pi f_x / f_s$  is in radians, before calculating the sin. This number should be converted to degrees (there are 57.29 degrees per one radian).

In this case, attenuation was calculated for 3.58 MHz and 4.43 MHz, the color subcarrier frequencies for NTSC and Pal, respectively.

$$A(3.58 \text{ MHz}) = .881$$

$$A(4.43 \text{ MHz}) = .834$$

The attenuation in decibels can be calculated from the formula:

$$\text{dB} = 20 \log(A(x))$$

This gives a value of  $-1.04$  dB down for 3.58 MHz and a value of  $-1.57$  dB down for 4.433 MHz. The filter, therefore, must provide a boost of 1.04 dB at 3.58 MHz, and of 1.57 dB at 4.433 MHz.

Figure 5 is a plot of the filter ranging from 1 MHz to 100 MHz and from 0 dB to  $-50$  dB down, and Figure 6 shows the same

frequency spread and a gain range from 0 dB to  $-20$  dB to better illustrate the  $\sin(x)/x$  correction.

Starting with a gain value of  $-6$  dB (as would be expected for the 50% DC signal drop across the termination resistor), it can be seen that at a frequency of 3.58 MHz the gain is  $-5$  dB, and at 4.43 MHz the gain is  $-4.5$  dB, a boost of 1 dB and 1.5 dB, respectively, as required (see Figure 6). Figure 5 shows an attenuation of  $-22$  dB at 8 MHz,  $-40$  dB at 9 MHz, and a value of  $-43$  dB at 13 MHz (the clock frequency).

Many different filters can be made to meet the  $\sin(x)/x$  requirement. This filter was chosen to provide augmentation up through the Pal subcarrier region. A filter with a cutoff at lower frequencies could be designed for use with NTSC only. This filter was also chosen for economic reasons, and more expensive filters could certainly be designed with improved performance. This filter was found to have a good performance to cost ratio and can be made from standard component values and 5% tolerance parts.

If large capacitive loads are expected to be encountered, it may be desirable to buffer the output filter with a high speed op amp. If this is the case, the filter should be terminated with a  $75 \Omega$  load at the input of the op amp. The op amp should be operated in non-inverting mode with a gain of two.

# CVBS output filter for SAA7199B encoder

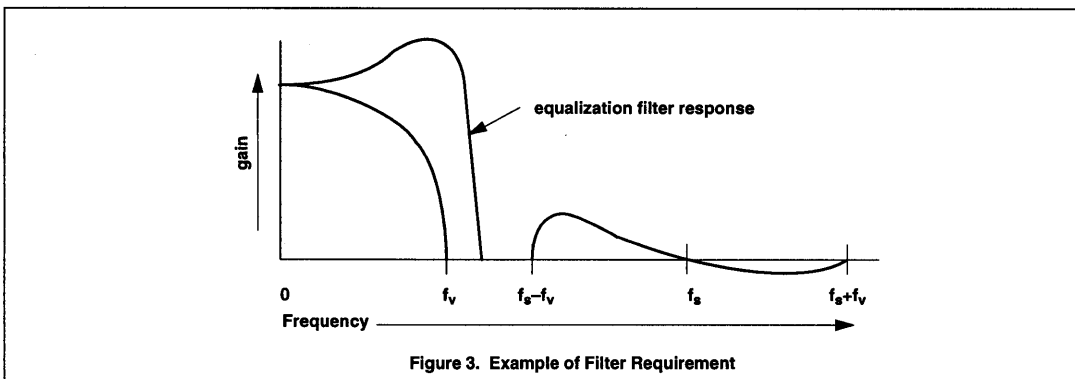
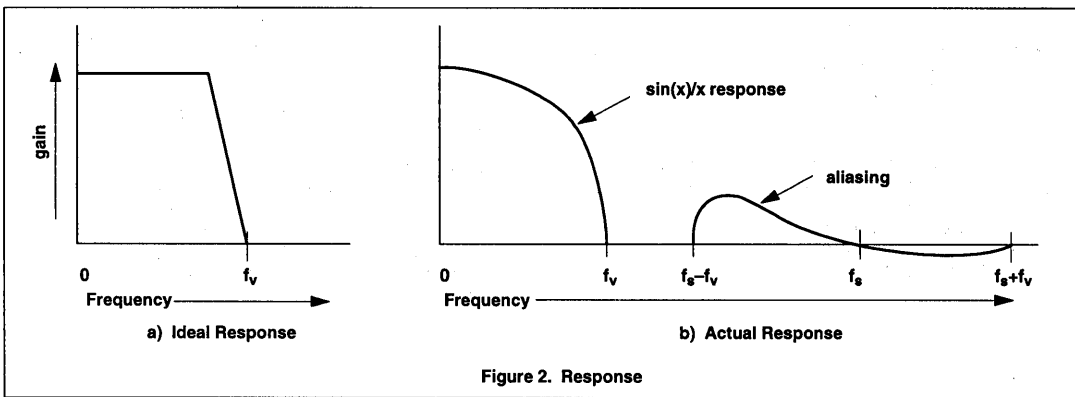
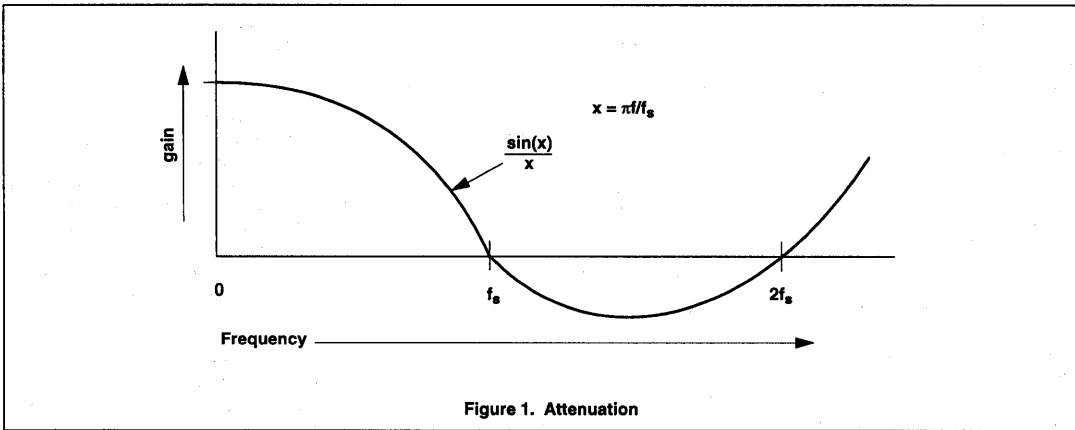

CVBS output filter for SAA7199B encoder

CVBS OUTPUT FILTER FOR PHILIPS SAA7199

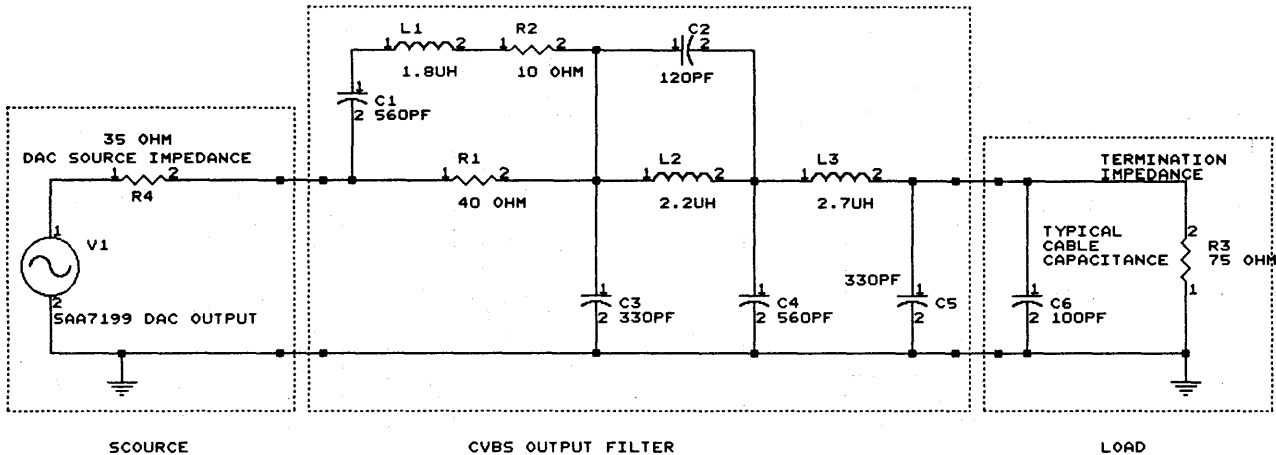

GENERALIZED VIDEO OUTPUT FILTER  
FOR PAL AND NTSC VIDEO

PROVIDES SIN(X)/X COMPENSATION

- 1) +1.04 dB AT 3.58 MHz
- 2) +1.58 dB AT 4.43 MHz

PHILIPS SEMICONDUCTORS	
GEORGE ELLIS	
Title	
CVBS OUTPUT FILTER	
Size	Document Number
A	A
Date:	February 1, 1993 Sheet 1 of 1

Figure 4. CVBS Output Filter

CVBS output filter for SAA7199B encoder

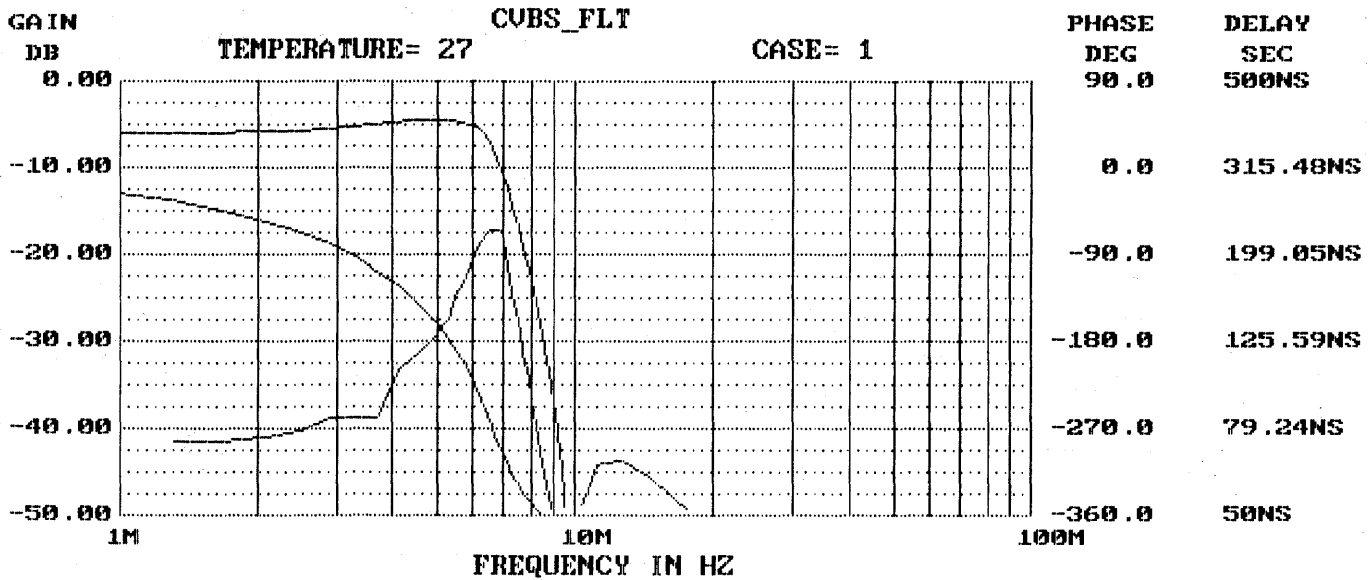

Frequency = 100.00000D+06 HZ      Gain = -93.270 DB  
 Phase angle= -624.899 Degrees      Group delay= 207.67632D-12 Sec  
 Gain slope = -179.95903E-01 DB/OCT      Peak gain = -4.492DB/F= 530.00001D+04

Figure 5. Plot of the Filter Ranging from 1MHz to 100MHz and from 0 dB to -50 dB

CVBS output filter for SAA7199B encoder

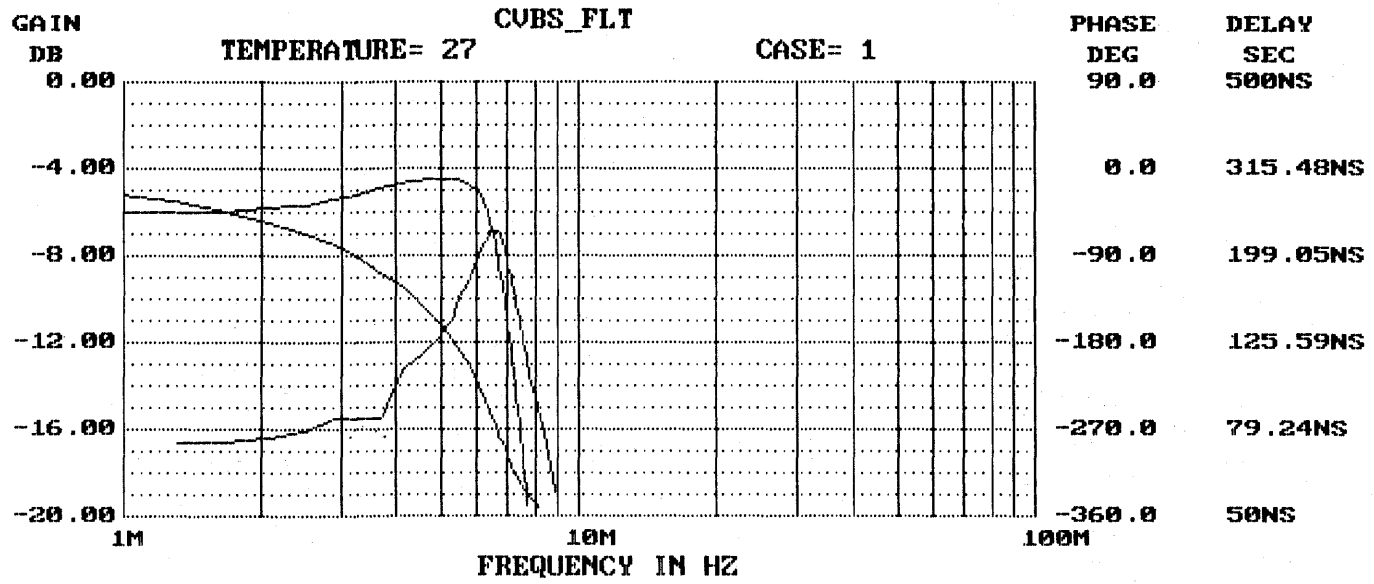

Frequency = 100.00000D+06 HZ      Gain = -93.270 DB  
 Phase angle= -624.899 Degrees      Group delay= 241.04590D-12 Sec  
 Gain slope = -179.83192E-01 DB/OCT      Peak gain = -4.492DB/F= 530.00001D+04

Figure 6. Plot of the Filter Ranging from 1MHz to 100MHz and from 0 dB to -20 dB

# SAA1101 sync generator application

## LOCK TO SUBCARRIER

The SAA1101 can be configured to run in a mode in which the output pulses are locked to a subcarrier signal that is either internally generated (as shown here), or can be applied as an AC coupled, low level input to pin 1.

The internal clock oscillator is used here with the frequency selected to be 2.517482MHz (CS0 and CS1 = 0). Remember that for different choices of oscillator frequency, the LC values of the tank circuit (L1 and C11) will change accordingly.

The NTSC1 system is selected in this example; all outputs are active HIGH (see waveforms shown in data sheets).

## LOCK TO EXTERNAL COMPOSITE SYNC

This schematic illustrates a lock to external sync application that uses an external PLL to generate a clock that is optimized for stability. Monostables are added to the reference and variable phase detector inputs to allow offsetting the sync outputs with respect to the composite sync input signal.

As above, the NTSC1 standard and 2.517482MHz clock are selected. The use of an external PLL (the HC4046) along with optimized loop filters and stable discrete components, produces a very stable clock (5 percent, or better, resistors and COG capacitors are recommended).

The lock mode selection is not critical in this

application because the internal oscillator is not used; LM0 and LM1 are grounded for convenience. The subcarrier input at pin 1 is used as an inverter for the output of the sync stripper before it is fed to the ESC input (pin 11), which requires an active HIGH signal.

Either pot R4 or pot R8 will move the generated sync output relative to sync in, therefore, only one need be adjustable. Pot R11 is used to adjust the oscillator free-run frequency. R10, pot R11, and C9 must be temperature stable parts for oscillator frequency stability over temperature.

The outputs of the SAA1101 are active HIGH signals which can directly drive inverting buffers for use as conventional active LOW drivers.

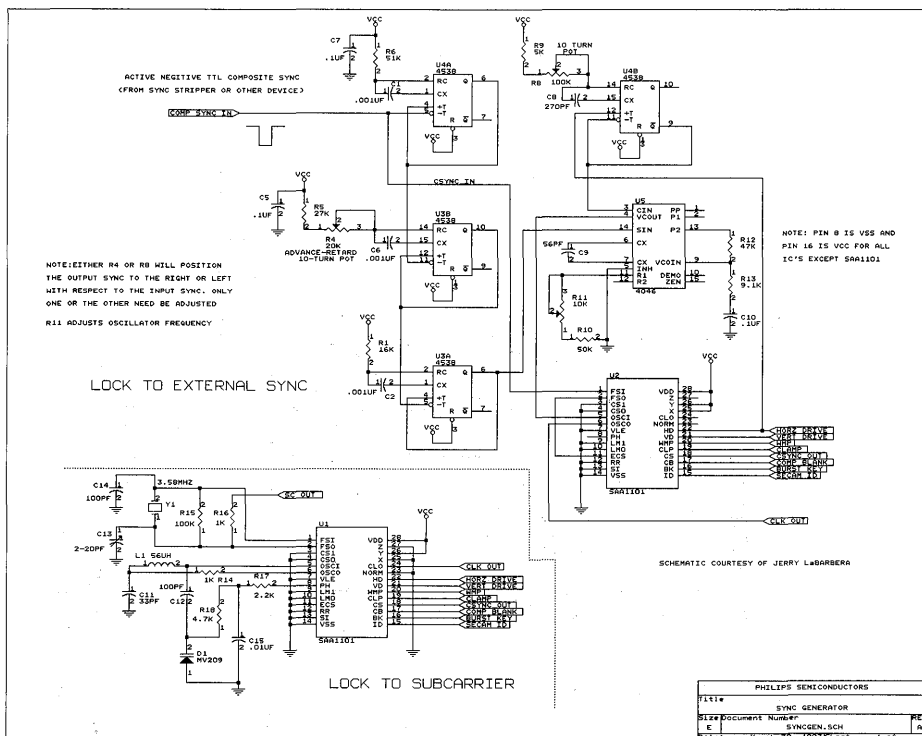

# The I<sup>2</sup>C-bus and how to use it (including specification)

## 1.0 THE I<sup>2</sup>C-BUS BENEFITS DESIGNERS AND MANUFACTURERS

In consumer electronics, telecommunications and industrial electronics, there are often many similarities between seemingly unrelated designs. For example, nearly every system includes:

- Some intelligent control, usually a single-chip microcontroller
- General-purpose circuits like LCD drivers, remote I/O ports, RAM, EEPROM, or data converters
- Application-oriented circuits such as digital tuning and signal processing circuits for radio and video systems, or DTMF generators for telephones with tone dialling

To exploit these similarities to the benefit of both systems designers and equipment manufacturers, as well as to maximize hardware efficiency and circuit simplicity, Philips developed a simple bidirectional 2-wire bus for efficient inter-IC control. This bus is called the Inter IC or I<sup>2</sup>C-bus. At present, Philips' IC range includes more than 150 CMOS and bipolar I<sup>2</sup>C-bus compatible types for performing functions in all three of the previously mentioned categories. All I<sup>2</sup>C-bus compatible devices incorporate an on-chip interface which allows them to communicate directly with each other via the I<sup>2</sup>C-bus. This design concept solves the many interfacing problems encountered when designing digital control circuits.

Here are some of the features of the I<sup>2</sup>C-bus:

- Only two bus lines are required; a serial data line (SDA) and a serial clock line (SCL)
- Each device connected to the bus is software addressable by a unique address and simple master/ slave relationships exist at all times; masters can operate as master-transmitters or as master-receivers
- It's a true multi-master bus including collision detection and arbitration to prevent data corruption if two or more masters simultaneously initiate data transfer
- Serial, 8-bit oriented, bidirectional data transfers can be made at up to 100 kbit/s in the standard mode or up to 400 kbit/s in the fast mode
- On-chip filtering rejects spikes on the bus

data line to preserve data integrity

- The number of ICs that can be connected to the same bus is limited only by a maximum bus capacitance of 400 pF

Figure 1 shows two examples of I<sup>2</sup>C-bus applications.

### 1.1 Designer Benefits

I<sup>2</sup>C-bus compatible ICs allow a system design to rapidly progress directly from a functional block diagram to a prototype. Moreover, since they 'clip' directly onto the I<sup>2</sup>C-bus without any additional external interfacing, they allow a prototype system to be modified or upgraded simply by 'clipping' or 'unclipping' ICs to or from the bus.

Here are some of the features of I<sup>2</sup>C-bus compatible ICs which are particularly attractive to designers:

- Functional blocks on the block diagram correspond with the actual ICs; designs proceed rapidly from block diagram to final schematic
- No need to design bus interfaces because the I<sup>2</sup>C-bus interface is already integrated on-chip
- Integrated addressing and data-transfer protocol allow systems to be completely software-defined
- The same IC types can often be used in many different applications
- Design-time reduces as designers quickly become familiar with the frequently used functional blocks represented by I<sup>2</sup>C-bus compatible ICs
- ICs can be added to or removed from a system without affecting any other circuits on the bus
- Fault diagnosis and debugging are simple; malfunctions can be immediately traced
- Software development time can be reduced by assembling a library of reusable software modules.

In addition to these advantages, the CMOS ICs in the I<sup>2</sup>C-bus compatible range offer designers special features which are particularly attractive for portable equipment and battery-backed systems.

They all have:

- Extremely low current consumption
- High noise immunity

- Wide supply voltage range
- Wide operating temperature range.

### 1.2 Manufacturer benefits

I<sup>2</sup>C-bus compatible ICs don't only assist designers, they also give a wide range of benefits to equipment manufacturers because:

- The simple 2-wire serial I<sup>2</sup>C-bus minimizes interconnections so ICs have fewer pins and there are not so many PCB tracks; result – smaller and less expensive PCBs
- The completely integrated I<sup>2</sup>C-bus protocol eliminates the need for address decoders and other 'glue logic'
- The multi-master capability of the I<sup>2</sup>C-bus allows rapid testing and alignment of end-user equipment via external connections to an assembly-line computer
- The availability of I<sup>2</sup>C-bus compatible ICs in SO (small outline), VSO (very small outline) as well as DIL packages reduces space requirements even more.

These are just some of the benefits.

In addition, I<sup>2</sup>C-bus compatible ICs increase system design flexibility by allowing simple construction of equipment variants and easy upgrading to keep designs up-to-date. In this way, an entire family of equipment can be developed around a basic model. Upgrades for new equipment, or enhanced-feature models (i.e. extended memory, remote control, etc.) can then be produced simply by clipping the appropriate ICs onto the bus. If a larger ROM is needed, it's simply a matter of selecting a microcontroller with a larger ROM from our comprehensive range. As new ICs supersede older ones, it's easy to add new features to equipment or to increase its performance by simply unclipping the outdated IC from the bus and clipping on its successor.

### 1.3 The ACCESS.bus

Another attractive feature of the I<sup>2</sup>C-bus for designers and manufacturers is that its simple 2-wire nature and capability of software addressing make it an ideal platform for the ACCESS.bus (Fig.2). This is a lower-cost alternative for an RS-232C interface for connecting peripherals to a host computer via a simple 4-pin connector (see Section 19).

# The I<sup>2</sup>C-bus and how to use it (including specification)

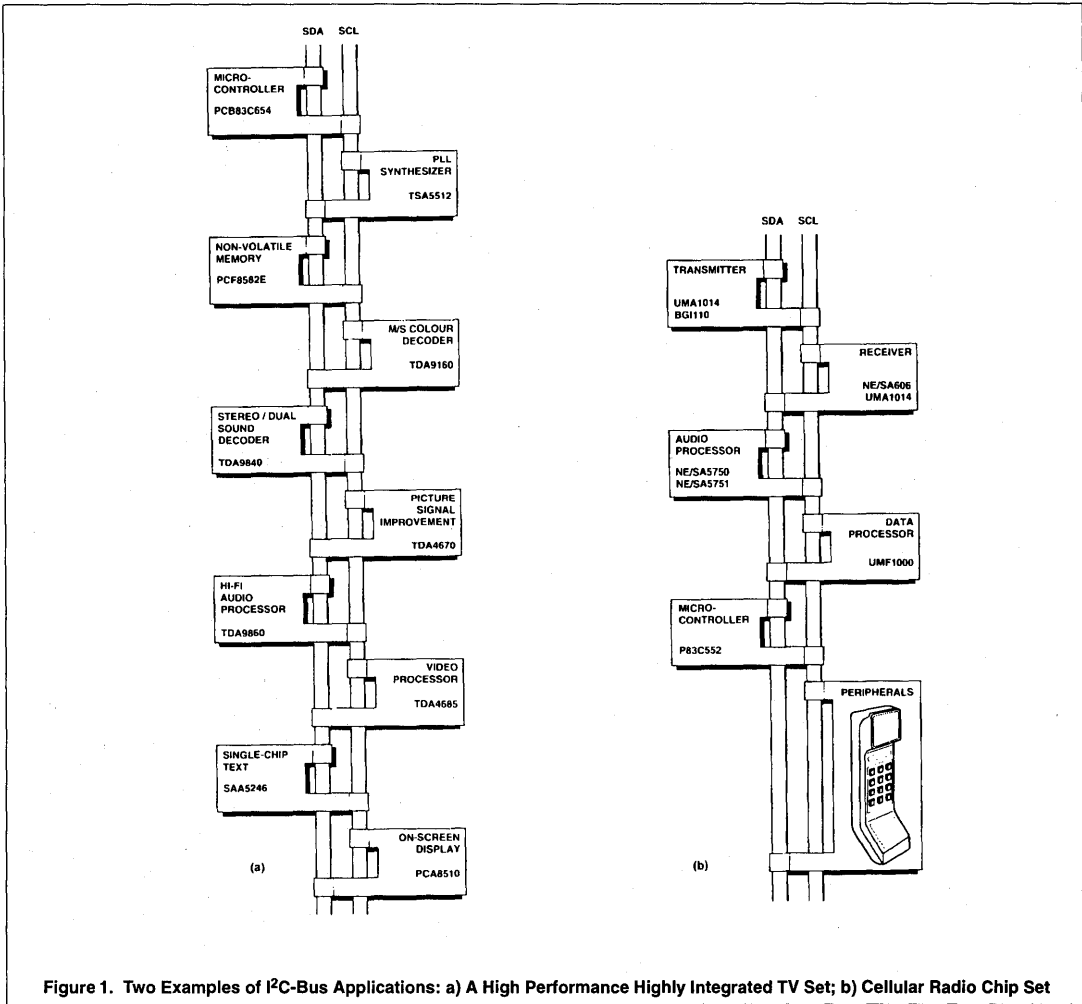

Table 1. Definition of I<sup>2</sup>C-Bus Terminology

Term	Description
Transmitter	The device which sends the data to the bus
Receiver	The device which receives the data from the bus
Master	The device which initiates a transfer, generates clock signals and terminates a transfer
Slave	The device addressed by a master
Multi-master	More than one master can attempt to control the bus at the same time without corrupting the message
Arbitration	Procedure to ensure that, if more than one master simultaneously tries to control the bus, only one is allowed to do so and the message is not corrupted
Synchronization	Procedure to synchronize the clock signals of two or more devices



# The I<sup>2</sup>C-bus and how to use it (including specification)

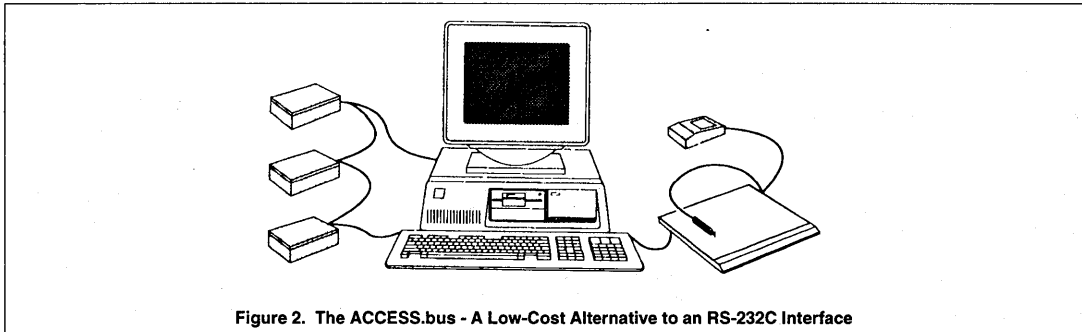

Figure 2. The ACCESS.bus - A Low-Cost Alternative to an RS-232C Interface

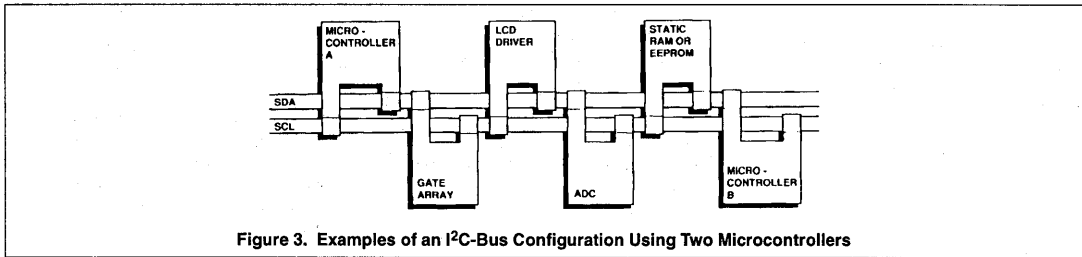

Figure 3. Examples of an I<sup>2</sup>C-Bus Configuration Using Two Microcontrollers

## 2.0 INTRODUCTION TO THE I<sup>2</sup>C-BUS SPECIFICATION

For 8-bit digital control applications, such as those requiring microcontrollers, certain design criteria can be established:

- A complete system usually consists of at least one microcontroller and other peripheral devices such as memories and I/O expanders
- The cost of connecting the various devices within the system must be minimized
- A system that performs a control function doesn't require high-speed data transfer
- Overall efficiency depends on the devices chosen and the nature of the interconnecting bus structure.

In order to produce a system to satisfy these criteria, a serial bus structure is needed. Although serial buses don't have the throughput capability of parallel buses, they do require less wiring and fewer IC connecting pins. However, a bus is not merely an interconnecting wire, it embodies all the formats and procedures for communication within the system.

Devices communicating with each other on a serial bus must have some form of protocol which avoids all possibilities of confusion, data loss and blockage of information. Fast devices must be able to communicate with slow devices. The system must not be dependent on the devices connected to it,

otherwise modifications or improvements would be impossible. A procedure has also to be devised to decide which device will be in control of the bus and when. And, if different devices with different clock speeds are connected to the bus, the bus clock source must be defined. All these criteria are involved in the specification of the I<sup>2</sup>C-bus.

## 3.0 THE I<sup>2</sup>C-BUS CONCEPT

The I<sup>2</sup>C-bus supports any IC fabrication process (NMOS, CMOS, bipolar). Two wires, serial data (SDA) and serial clock (SCL), carry information between the devices connected to the bus. Each device is recognised by a unique address – whether it's a microcontroller, LCD driver, memory or keyboard interface – and can operate as either a transmitter or receiver, depending on the function of the device. Obviously an LCD driver is only a receiver, whereas a memory can both receive and transmit data. In addition to transmitters and receivers, devices can also be considered as masters or slaves when performing data transfers (see Table 1). A master is the device which initiates a data transfer on the bus and generates the clock signals to permit that transfer. At that time, any device addressed is considered a slave.

The I<sup>2</sup>C-bus is a multi-master bus. This means that more than one device capable of

controlling the bus can be connected to it. As masters are usually micro-controllers, let's consider the case of a data transfer between two microcontrollers connected to the I<sup>2</sup>C-bus (Fig.3). This highlights the master-slave and receiver-transmitter relationships to be found on the I<sup>2</sup>C-bus. It should be noted that these relationships are

not permanent, but only depend on the direction of data transfer at that time. The transfer of data would proceed as follows:

1. Suppose microcontroller A wants to send information to microcontroller B:
  - microcontroller A (master), addresses microcontroller B (slave)
  - microcontroller A (master-transmitter), sends data to microcontroller B (slave-receiver)
  - microcontroller A terminates the transfer.
2. If microcontroller A wants to receive information from microcontroller B:
  - microcontroller A (master) addresses microcontroller B (slave)
  - microcontroller A (master-receiver) receives data from microcontroller B (slave-transmitter)
  - microcontroller A terminates the transfer.

Even in this case, the master (microcontroller A) generates the timing and terminates the transfer.

The possibility of connecting more than one microcontroller to the I<sup>2</sup>C-bus means that

# The I<sup>2</sup>C-bus and how to use it (including specification)

more than one master could try to initiate a data transfer at the same time. To avoid the chaos that might ensue from such an event – an arbitration procedure has been developed. This procedure relies on the wired-AND connection of all I<sup>2</sup>C interfaces to the I<sup>2</sup>C-bus.

If two or more masters try to put information onto the bus, the first to produce a 'one' when the other produces a 'zero' will lose the arbitration. The clock signals during arbitration are a synchronized combination of the clocks generated by the masters using the wired-AND connection to the SCL line (for more detailed information concerning arbitration see Section 7.0).

Generation of clock signals on the I<sup>2</sup>C-bus is always the responsibility of master devices; each master generates its own clock signals when transferring data on the bus. Bus clock signals from a master can only be altered when they are stretched by a slow-slave device holding-down the clock line, or by another master when arbitration occurs.

## 4.0 GENERAL CHARACTERISTICS

Both SDA and SCL are bidirectional lines, connected to a positive supply voltage via a pull-up resistor (see Fig.4). When the bus is free, both lines are HIGH. The output stages of devices connected to the bus must have an open-drain or open-collector in order to perform the wired-AND function. Data on the I<sup>2</sup>C-bus can be transferred at a rate up to 100 kbit/s in the standard-mode, or up to 400 kbit/s in the fast-mode. The number of interfaces connected to the bus is solely dependent on the bus capacitance limit of 400 pF.

## 5.0 BIT TRANSFER

Due to the variety of different technology devices (CMOS, NMOS, bipolar) which can be connected to the I<sup>2</sup>C-bus, the levels of the logical '0' (LOW) and '1' (HIGH) are not fixed and depend on the associated level of V<sub>DD</sub> (see Section 15.0 for Electrical Specifications). One clock pulse is generated for each data bit transferred.

## 5.1 Data Validity

The data on the SDA line must be stable

during the HIGH period of the clock. The HIGH or LOW state of the data line can only change when the clock signal on the SCL line is LOW (see Fig.5).

## 5.2 START and STOP Conditions

Within the procedure of the I<sup>2</sup>C-bus, unique situations arise which are defined as START and STOP conditions (see Fig.6).

A HIGH to LOW transition on the SDA line while SCL is HIGH is one such unique case. This situation indicates a START condition.

A LOW to HIGH transition on the SDA line while SCL is HIGH defines a STOP condition.

START and STOP conditions are always generated by the master. The bus is considered to be busy after the START condition. The bus is considered to be free again a certain time after the STOP condition. This bus free situation is specified in Section 15.0.

Detection of START and STOP conditions by devices connected to the bus is easy if they incorporate the necessary interfacing hardware. However, microcontrollers with no such interface have to sample the SDA line at least twice per clock period in order to sense the transition.

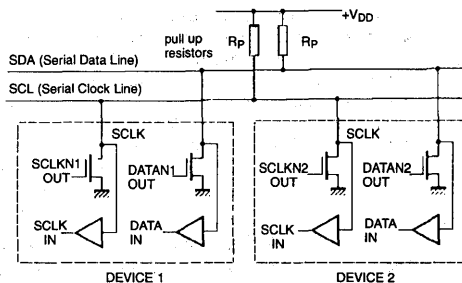

Figure 4. Connection of I<sup>2</sup>C-Bus Devices to the I<sup>2</sup>C-Bus

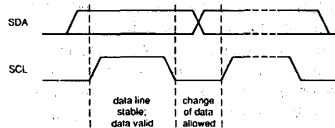

Figure 5. Bit Transfer on the I<sup>2</sup>C-Bus

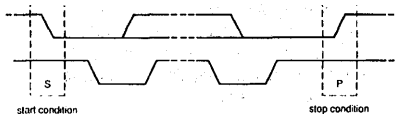
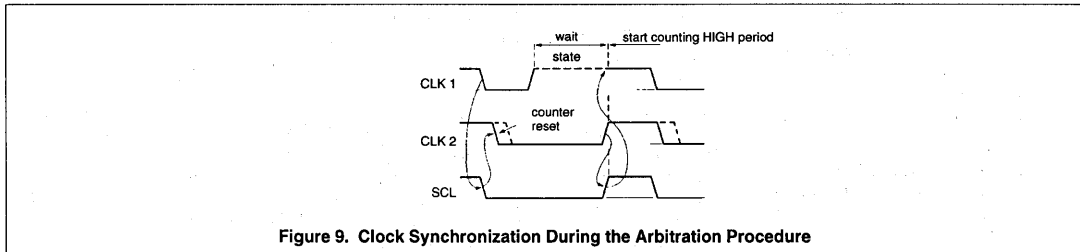
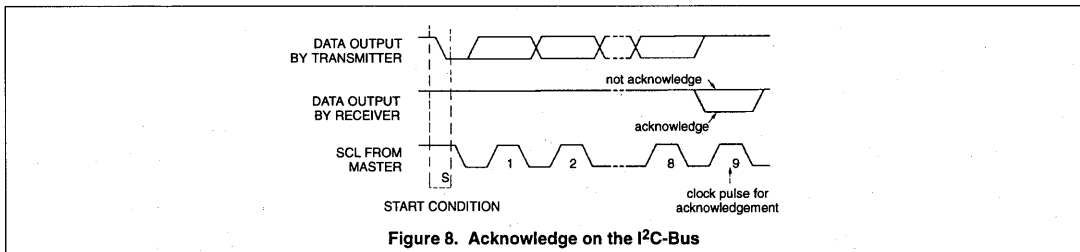
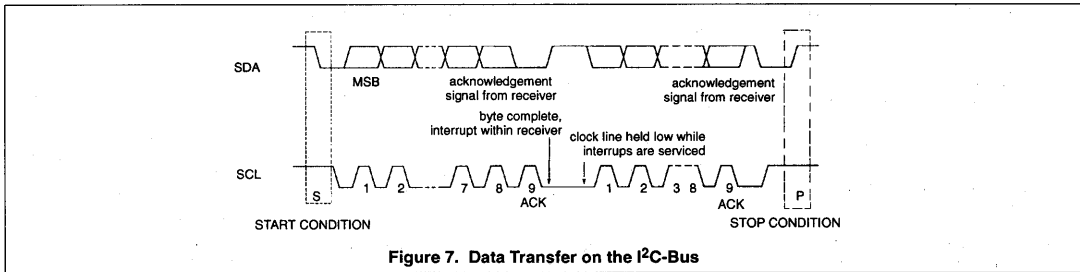

Figure 6. START and STOP Conditions

# The I<sup>2</sup>C-bus and how to use it (including specification)



## 6.0 TRANSFERRING DATA

### 6.1 Byte Format

Every byte put on the SDA line must be 8-bits long. The number of bytes that can be transmitted per transfer is unrestricted. Each byte has to be followed by an acknowledge bit. Data is transferred with the most significant bit (MSB) first (Fig.7). If a receiver can't receive another complete byte of data until it has performed some other function, for example servicing an internal interrupt, it can hold the clock line SCL LOW to force the transmitter into a wait state. Data transfer then continues when the receiver is ready for another byte of data and releases clock line SCL.

In some cases, it's permitted to use a different format from the I<sup>2</sup>C-bus format (for CBUS compatible devices for example). A message which starts with such an address can be terminated by generation of a STOP

condition, even during the transmission of a byte. In this case, no acknowledgement is generated (see Section 9.1.3).

### 6.2 Acknowledge

Data transfer with acknowledge is obligatory. The acknowledge-related clock pulse is generated by the master. The transmitter releases the SDA line (HIGH) during the acknowledge clock pulse.

The receiver must pull down the SDA line during the acknowledge clock pulse so that it remains stable LOW during the HIGH period of this clock pulse (Fig.8). Of course, set-up and hold times (specified in Section 15) must also be taken into account.

Usually, a receiver which has been addressed is obliged to generate an acknowledge after each byte has been received, except when the message starts with a CBUS address (see Section 9.1.3).

When a slave-receiver doesn't acknowledge the slave address (for example, it's unable to receive because it's performing some real-time function), the data line must be left HIGH by the slave. The master can then generate a STOP condition to abort the transfer.

If a slave-receiver does acknowledge the slave address but, some time later in the transfer cannot receive any more data bytes, the master must again abort the transfer. This is indicated by the slave generating the not acknowledge on the first byte to follow. The slave leaves the data line HIGH and the master generates the STOP condition.

If a master-receiver is involved in a transfer, it must signal the end of data to the slave-transmitter by not generating an acknowledge on the last byte that was clocked out of the slave. The slave-transmitter must release the data line to allow the master to generate the STOP condition.

# The I<sup>2</sup>C-bus and how to use it (including specification)

## 7.0 ARBITRATION AND CLOCK GENERATION

### 7.1 Synchronization

All masters generate their own clock on the SCL line to transfer messages on the I<sup>2</sup>C-bus. Data is only valid during the HIGH period of the clock. A defined clock is therefore needed for the bit-by-bit arbitration procedure to take place.

Clock synchronization is performed using the wired-AND connection of I<sup>2</sup>C interfaces to the SCL line. This means that a HIGH to LOW transition on the SCL line will cause the devices concerned to start counting off their LOW period and, once a device clock has gone LOW, it will hold the SCL line in that state until the clock HIGH state is reached (Fig.9). However, the LOW to HIGH transition of this clock may not change the state of the SCL line if another clock is still within its LOW period. The SCL line will therefore be held LOW by the device with the longest LOW period. Devices with shorter LOW periods enter a HIGH wait-state during this time.

When all devices concerned have counted off their LOW period, the clock line will be released and go HIGH. There will then be no difference between the device clocks and the state of the SCL line, and all the devices will start counting their HIGH periods. The first device to complete its HIGH period will again pull the SCL line LOW.

In this way, a synchronized SCL clock is generated with its LOW period determined by the device with the longest clock LOW period, and its HIGH period determined by the one with the shortest clock HIGH period.

### 7.2 Arbitration

A master may start a transfer only if the bus is free. Two or more masters may generate a START condition within the minimum hold

time ( $t_{HD,STA}$ ) of the START condition which results in a defined START condition to the bus.

Arbitration takes place on the SDA line, while the SCL line is at the HIGH level, in such a way that the master which transmits a HIGH level, while another master is transmitting a LOW level will switch off its DATA output stage because the level on the bus doesn't correspond to its own level.

Arbitration can continue for many bits. Its first stage is comparison of the address bits (addressing information is in Sections 9.0 and 13.0). If the masters are each trying to address the same device, arbitration continues with comparison of the data. Because address and data information on the I<sup>2</sup>C-bus is used for arbitration, no information is lost during this process.

A master which loses the arbitration can generate clock pulses until the end of the byte in which it loses the arbitration.

If a master also incorporates a slave function and it loses

arbitration during the addressing stage, it's possible that the winning master is trying to address it. The losing master must therefore switch over immediately to its slave-receiver mode.

Figure 10 shows the arbitration procedure for two masters. Of course, more may be involved (depending on how many masters are connected to the bus). The moment there is a difference between the internal data level of the master generating DATA 1 and the actual level on the SDA line, its data output is switched off, which means that a HIGH output level is then connected to the bus. This will not affect the data transfer initiated by the winning master.

Since control of the I<sup>2</sup>C-bus is decided solely on the address and data sent by competing

masters, there is no central master, nor any order of priority on the bus.

Special attention must be paid if, during a serial transfer, the arbitration procedure is still in progress at the moment when a repeated START condition or a STOP condition is transmitted to the I<sup>2</sup>C-bus. If it's possible for such a situation to occur, the masters involved must send this repeated START condition or STOP condition at the same position in the format frame. In other words, arbitration isn't allowed between:

- A repeated START condition and a data bit
- A STOP condition and a data bit
- A repeated START condition and a STOP condition.

### 7.3 Use of the Clock Synchronising Mechanism as a Handshake

In addition to being used during the arbitration procedure, the clock synchronization mechanism can be used to enable receivers to cope with fast data transfers, on either a byte level or a bit level.

On the byte level, a device may be able to receive bytes of data at a fast rate, but needs more time to store a received byte or prepare another byte to be transmitted. Slaves can then hold the SCL line LOW after reception and acknowledgement of a byte to force the master into a wait state until the slave is ready for the next byte transfer in a type of handshake procedure.

On the bit level, a device such as a microcontroller without, or with only a limited hardware I<sup>2</sup>C interface on-chip can slow down the bus clock by extending each clock LOW period. The speed of any master is thereby adapted to the internal operating rate of this device.

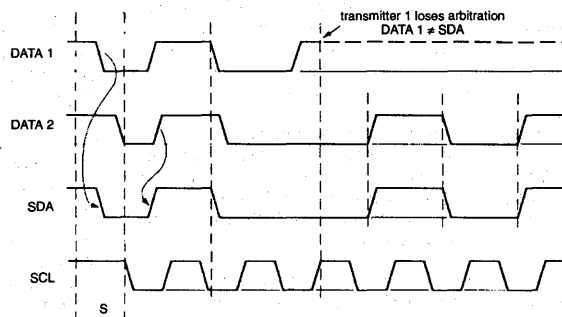

Figure 10. Arbitration Procedure of Two Masters

# The I<sup>2</sup>C-bus and how to use it (including specification)

## 8.0 FORMATS WITH 7-BIT ADDRESSES

Data transfers follow the format shown in Fig. 11. After the START condition (S), a slave address is sent. This address is 7 bits long followed by an eighth bit which is a data direction bit (R/W) – a 'zero' indicates a transmission (WRITE), a 'one' indicates a request for data (READ). A data transfer is always terminated by a STOP condition (P) generated by the master. However, if a master still wishes to communicate on the bus, it can generate a repeated START condition (Sr) and address another slave without first generating a STOP condition. Various combinations of read/write formats are then possible within such a transfer.

Possible data transfer formats are:

- Master-transmitter transmits to slave-receiver. The transfer direction is not changed (Fig.12)
- Master reads slave immediately after first byte (Fig.13). At the moment of the first acknowledge, the master-transmitter becomes a master-receiver and the slave-receiver becomes a slave-transmitter. This acknowledge is still generated by the slave. The STOP condition is generated by the master
- Combined format (Fig.14). During a change of direction within a transfer, the START condition and the slave address are both repeated, but with the R/W bit reversed.

NOTES:

1. Combined formats can be used, for example, to control a serial memory. During the first data byte, the internal memory location has to be written. After the START condition and slave address is repeated, data can be transferred.
2. All decisions on auto-increment or decrement of previously accessed memory locations etc. are taken by the designer of the device.
3. Each byte is followed by an acknowledgement bit as indicated by the A or  $\bar{A}$  blocks in the sequence.
4. I<sup>2</sup>C-bus compatible devices must reset their bus logic on receipt of a START or repeated START condition such that they all anticipate the sending of a slave address.

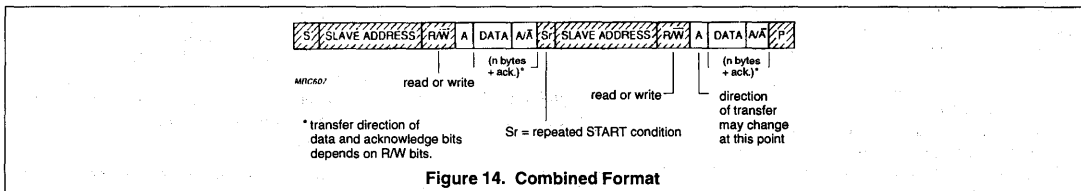
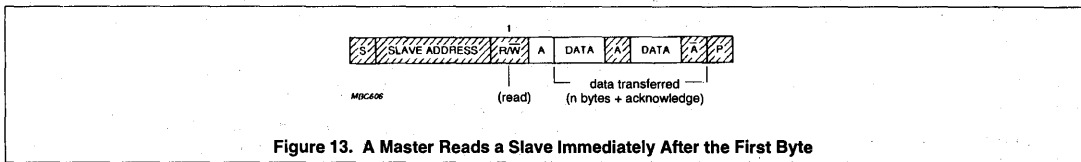
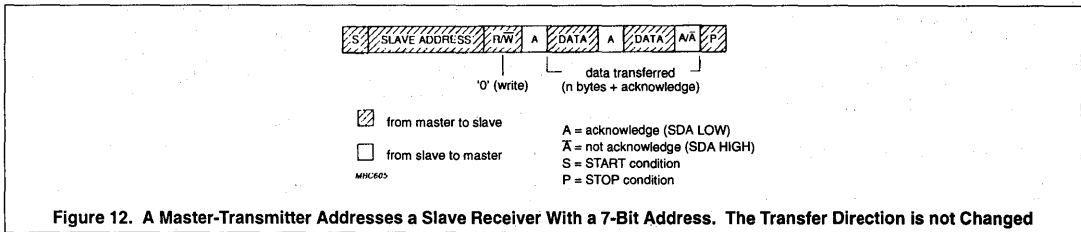
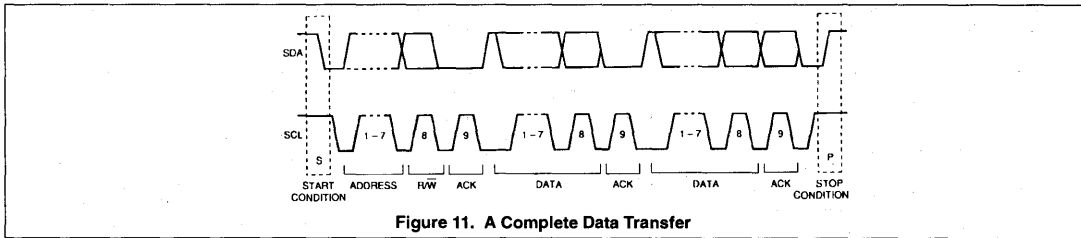

# The I<sup>2</sup>C-bus and how to use it (including specification)

**Table 2. Definition of Bits in the First Byte**

Slave address	R/ bit	Description
0000 000	0	General call address
0000 000	1	START byte
0000 001	X	CBUS address
0000 010	X	Address reserved for different bus format
0000 011	X	Reserved for future purposes
0000 1XX	X	Reserved for future purposes
1111 1XX	X	Reserved for future purposes
1111 0XX	X	10-bit slave addressing

**NOTES:**

1. No device is allowed to acknowledge at the reception of the START byte.
2. The CBUS address has been reserved to enable the inter-mixing of CBUS compatible and I<sup>2</sup>C-bus compatible devices in the same system. I<sup>2</sup>C-bus compatible devices are not allowed to respond on reception of this address.
3. The address reserved for a different bus format is included to enable I<sup>2</sup>C and other protocols to be mixed. Only I<sup>2</sup>C-bus compatible devices that can work with such formats and protocols are allowed to respond to this address.

## 9.0 7-BIT ADDRESSING (see Section 13.0 for 10-Bit Addressing)

The addressing procedure for the I<sup>2</sup>C-bus is such that the first byte after the START condition usually determines which slave will be selected by the master. The exception is the 'general call' address which can address all devices. When this address is used, all devices should, in theory, respond with an acknowledge. However, devices can be made to ignore this address. The second byte of the general call address then defines the action to be taken. This procedure is explained in more detail in Section 9.1.1.

### 9.1 Definition of Bits in the First Byte

The first seven bits of the first byte make up the slave address (Fig.15). The eighth bit is the LSB (least significant bit). It determines the direction of the message. A 'zero' in the least significant position of the first byte means that the master will write information to a selected slave. A 'one' in this position means that the master will read information from the slave.

When an address is sent, each device in a system compares the first seven bits after the START condition with its address. If they match, the device considers itself addressed by the master as a slave-receiver or slave-transmitter, depending on the R/W bit.

A slave address can be made-up of a fixed and a programmable part. Since it's likely that there will be several identical devices in a system, the programmable part of the slave address enables the maximum possible number of such devices to be connected to

the I<sup>2</sup>C-bus. The number of programmable address bits of a device depends on the number of pins available. For example, if a device has 4 fixed and 3 programmable address bits, a total of 8 identical devices can be connected to the same bus.

The I<sup>2</sup>C-bus committee coordinates allocation of I<sup>2</sup>C addresses. Further information can be obtained from the Philips representatives listed on the back cover. Two groups of eight addresses (0000XXX and 1111XXX) are reserved for the purposes shown in Table 2. The bit combination 11110XX of the slave address is reserved for 10-bit addressing (see Section 13).

#### 9.1.1 General Call Address

The general call address is for addressing every device connected to the I<sup>2</sup>C-bus. However, if a device doesn't need any of the data supplied within the general call structure, it can ignore this address by not issuing an acknowledgement. If a device does require data from a general call address, it will acknowledge this address and behave as a slave-receiver. The second and following bytes will be acknowledged by every slave-receiver capable of handling this data. A slave which cannot process one of these bytes must ignore it by not acknowledging. The meaning of the general call address is always specified in the second byte (Fig.16).

- There are two cases to consider:
- When the least significant bit B is a 'zero'
  - When the least significant bit B is a 'one'.

When bit B is a 'zero'; the second byte has the following definition:

- 00000110 (H'06'). Reset and write programmable part of slave address by hardware. On receiving this 2-byte sequence, all devices designed to respond to the general call address will reset and take in the programmable part of their address. Precautions have to be taken to ensure that a device is not pulling down the SDA or SCL line after applying the supply voltage, since these low levels would block the bus
- 00000100 (H'04'). Write programmable part of slave address by hardware. All devices which define the programmable part of their address by hardware (and which respond to the general call address) will latch this programmable part at the reception of this two byte sequence. The device will not reset.
- 00000000 (H'00'). This code is not allowed to be used as the second byte.

Sequences of programming procedure are published in the appropriate device data sheets.

The remaining codes have not been fixed and devices must ignore them.

When bit B is a 'one'; the 2-byte sequence is a 'hardware general call'. This means that the sequence is transmitted by a hardware master device, such as a keyboard scanner, which cannot be programmed to transmit a desired slave address. Since a hardware master doesn't know in advance to which device the message has to be transferred, it can only generate this hardware general call and its own address - identifying itself to the system (Fig.17).

The seven bits remaining in the second byte contain the address of the hardware master.

# The I<sup>2</sup>C-bus and how to use it (including specification)

This address is recognised by an intelligent device (e.g. a microcontroller) connected to the bus which will then direct the information from the hardware master. If the hardware master can also act as a slave, the slave address is identical to the master address.

In some systems, an alternative could be that the hardware master transmitter is set in the slave-receiver mode after the system reset. In this way, a system configuring master can tell the hardware master-transmitter (which is

now in slave-receiver mode) to which address data must be sent (Fig.18). After this programming procedure, the hardware master remains in the master-transmitter mode.

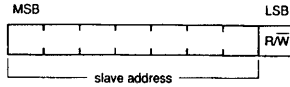

Figure 15. The First Byte After the START Procedure

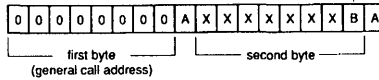

Figure 16. General Call Address Format

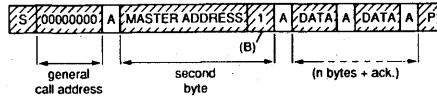

Figure 17. Data Transfer From a Hardware Master-Transmitter

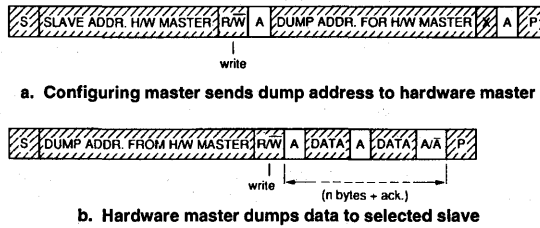
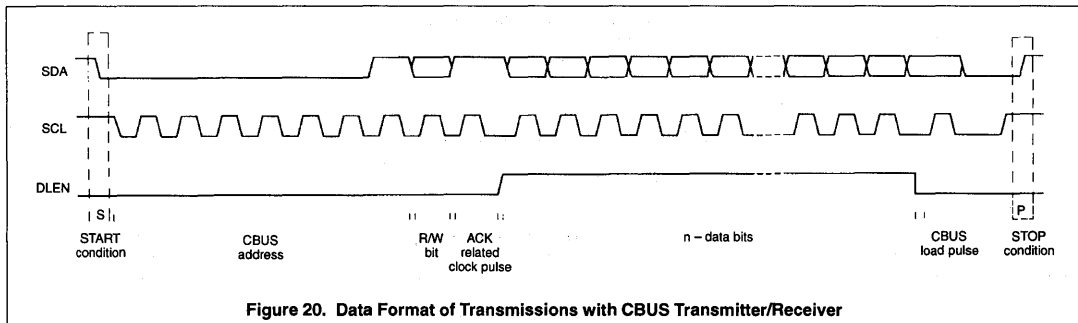
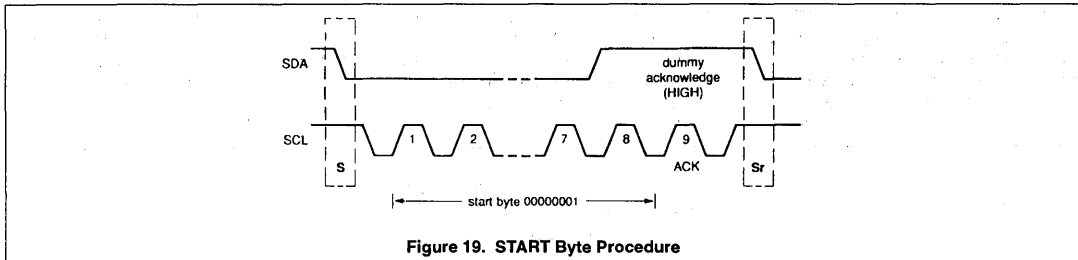

Figure 18. Data Transfer by a Hardware-Transmitter Capable of Dumping Data Directly to Slave Devices

# The I<sup>2</sup>C-bus and how to use it (including specification)



### 9.1.2 START byte

Microcontrollers can be connected to the I<sup>2</sup>C-bus in two ways. A microcontroller with an on-chip hardware I<sup>2</sup>C-bus interface can be programmed to be only interrupted by requests from the bus. When the device doesn't have such an interface, it must constantly monitor the bus via software. Obviously, the more times the microcontroller monitors, or polls the bus, the less time it can spend carrying out its intended function.

There is therefore a speed difference between fast hardware devices and a relatively slow microcontroller which relies on software polling.

In this case, data transfer can be preceded by a start procedure which is much longer than normal (Fig.19). The start procedure consists of:

- A START condition (S)
- A START byte (00000001)
- An acknowledge clock pulse (ACK)
- A repeated START condition (Sr).

After the START condition S has been

transmitted by a master which requires bus access, the START byte (00000001) is transmitted. Another microcontroller can therefore sample the SDA line at a low sampling rate until one of the seven zeros in the START byte is detected. After detection of this LOW level on the SDA line, the microcontroller can switch to a higher sampling rate to find the repeated START condition Sr which is then used for synchronization.

A hardware receiver will reset on receipt of the repeated START condition Sr and will therefore ignore the START byte.

An acknowledge-related clock pulse is generated after the START byte. This is present only to conform with the byte handling format used on the bus. No device is allowed to acknowledge the START byte.

### 9.1.3 CBUS Compatibility

CBUS receivers can be connected to the I<sup>2</sup>C-bus. However, a third bus line called DLEN must then be connected and the

acknowledge bit omitted. Normally, I<sup>2</sup>C transmissions are sequences of 8-bit bytes; CBUS compatible devices have different formats.

In a mixed bus structure, I<sup>2</sup>C-bus devices must not respond to the CBUS message. For this reason, a special CBUS address (0000001X) to which no I<sup>2</sup>C-bus compatible device will respond, has been reserved. After transmission of the CBUS address, the DLEN line can be made active and a CBUS-format transmission (Fig.20) sent. After the STOP condition, all devices are again ready to accept data.

Master-transmitters can send CBUS formats after sending the CBUS address. The transmission is ended by a STOP condition, recognised by all devices.

**NOTE:** If the CBUS configuration is known, and expansion with CBUS compatible devices isn't foreseen, the designer is allowed to adapt the hold time to the specific requirements of the device(s) used.



# The I<sup>2</sup>C-bus and how to use it (including specification)

## 10.0 ELECTRICAL CHARACTERISTICS FOR I<sup>2</sup>C-BUS DEVICES

The electrical specifications for the I/Os of I<sup>2</sup>C-bus devices and the characteristics of the bus lines connected to them are given in Tables 3 and 4 in Section 15.

I<sup>2</sup>C-bus devices with fixed input levels of 1.5 V and 3 V can each have their own appropriate supply voltage. Pull-up resistors

must be connected to a 5 V ± 10% supply (Fig.21). I<sup>2</sup>C-bus devices with input levels related to V<sub>DD</sub> must have one common supply line to which the pull-up resistor is also connected (Fig.22).

When devices with fixed input levels are mixed with devices with input levels related to V<sub>DD</sub>, the latter devices must be connected to one common supply line of 5 V ± 10% and must have pull-up resistors connected to their SDA and SCL pins as shown in Fig.23.

Input levels are defined in such a way that:

- The noise margin on the LOW level is 0.1 V<sub>DD</sub>
- The noise margin on the HIGH level is 0.2 V<sub>DD</sub>
- As shown in Fig.24, series resistors (R<sub>S</sub>) of e.g. 300 Ω can be used for protection against high-voltage spikes on the SDA and SCL lines (due to flash-over of a TV picture tube, for example).

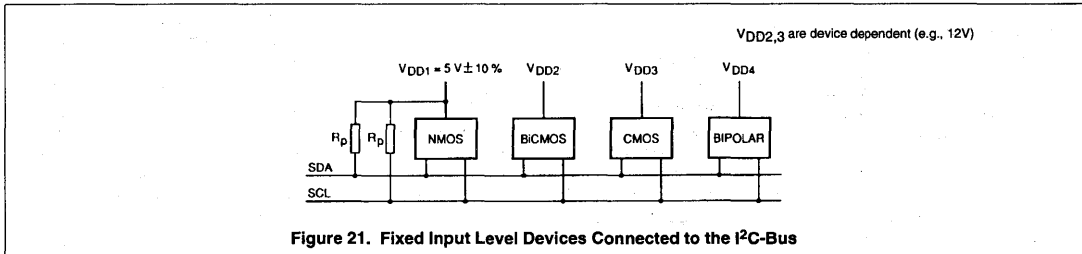

Figure 21. Fixed Input Level Devices Connected to the I<sup>2</sup>C-Bus

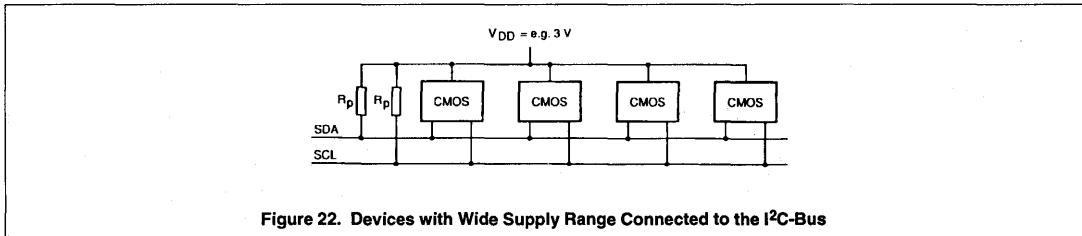

Figure 22. Devices with Wide Supply Range Connected to the I<sup>2</sup>C-Bus

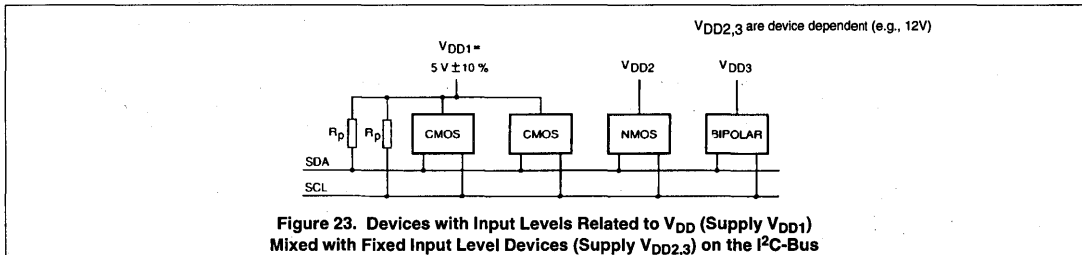

Figure 23. Devices with Input Levels Related to V<sub>DD</sub> (Supply V<sub>DD1</sub>) Mixed with Fixed Input Level Devices (Supply V<sub>DD2,3</sub>) on the I<sup>2</sup>C-Bus

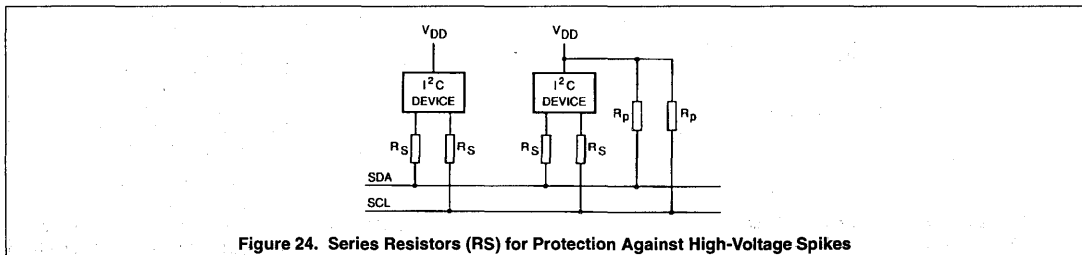

Figure 24. Series Resistors (R<sub>S</sub>) for Protection Against High-Voltage Spikes

# The I<sup>2</sup>C-bus and how to use it (including specification)

## 10.1 Maximum and minimum values of resistors R<sub>P</sub> and R<sub>S</sub>

For standard-mode I<sup>2</sup>C-bus devices, the values of resistors R<sub>P</sub> and R<sub>S</sub> in Fig.24 depend on the following parameters:

- Supply voltage
- Bus capacitance
- Number of connected devices (input current + leakage current).

The supply voltage limits the minimum value of resistor R<sub>P</sub> due

to the specified minimum sink current of 3 mA at V<sub>OLmax</sub> = 0.4 V for the output stages. V<sub>DD</sub> as a function of R<sub>P min</sub> is shown in Fig.25. The desired noise margin of 0.1V<sub>DD</sub> for the LOW level, limits the maximum value of R<sub>S</sub>. R<sub>S max</sub> as a function of R<sub>P</sub> is shown in Fig.26.

The bus capacitance is the total capacitance of wire, connections and pins. This capacitance limits the maximum value of R<sub>P</sub> due to the specified rise time. Fig.27 shows

R<sub>P max</sub> as a function of bus capacitance.

The maximum HIGH level input current of each input/output connection has a specified maximum value of 10 μA. Due to the desired noise margin of 0.2V<sub>DD</sub> for the HIGH level, this input current limits the maximum value of R<sub>P</sub>. This limit depends on V<sub>DD</sub>. The total HIGH level input current is shown as a function of R<sub>P max</sub> in Fig.28.

## 11.0 EXTENSIONS TO THE I<sup>2</sup>C-BUS SPECIFICATION

The I<sup>2</sup>C-bus with a data transfer rate of up to 100 kbit/s and 7-bit addressing has now been in existence for more than ten years with an unchanged specification. The concept is accepted world-wide as a de facto standard and hundreds of different types of I<sup>2</sup>C-bus compatible ICs are available from Philips and other suppliers. The I<sup>2</sup>C-bus specification is now extended with the following two features:

- A fast-mode which allows a fourfold increase of the bit rate to 0 to 400 kbit/s
- 10-bit addressing which allows the use of up to 1024 additional addresses.

There are two reasons for these extensions to the I<sup>2</sup>C-bus specification:

- New applications will need to transfer a larger amount of serial data and will therefore demand a higher bit rate than 100 kbit/s. Improved IC manufacturing technology now allows a fourfold speed increase without increasing the manufacturing cost of the interface circuitry
- Most of the 112 addresses available with the 7-bit addressing scheme have been issued more than once. To prevent problems with the allocation of slave addresses for new devices, it is desirable to have more address combinations. About a tenfold increase of the number of available addresses is obtained with the new 10-bit addressing.

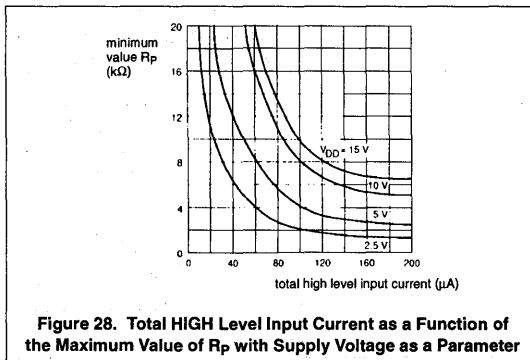
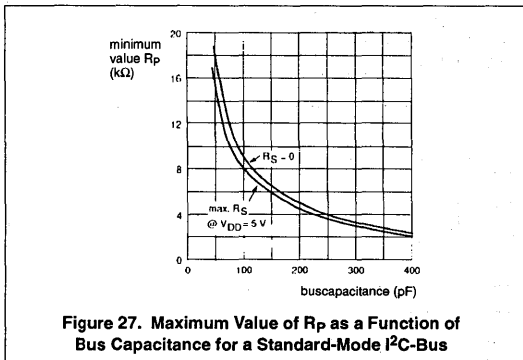
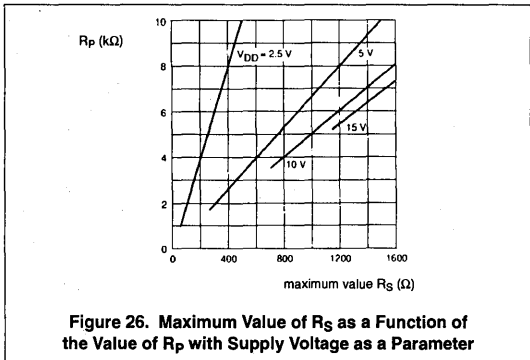
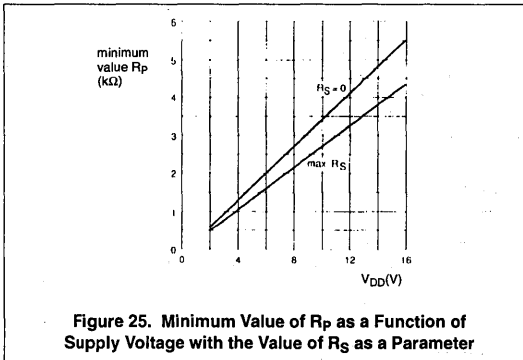

## The I<sup>2</sup>C-bus and how to use it (including specification)

All new devices with an I<sup>2</sup>C-bus interface are provided with the fast-mode. Preferably, they should be able to receive and/or transmit at 400 kbit/s. The minimum requirement is that they can synchronize with a 400 kbit/s transfer; they can then prolong the LOW period of the SCL signal to slow down the transfer. Fast-mode devices must be downward-compatible which means that they must still be able to communicate with 0 to 100 kbit/s devices in a 0 to 100 kbit/s I<sup>2</sup>C-bus system.

Obviously, devices with a 0 to 100 kbit/s I<sup>2</sup>C-bus interface cannot be incorporated in a fast-mode I<sup>2</sup>C-bus system because, since they cannot follow the higher transfer rate, unpredictable states of these devices would occur.

Slave devices with a fast-mode I<sup>2</sup>C-bus interface can have a 7-bit or a 10-bit slave address. However, a 7-bit address is preferred because it is the cheapest solution in hardware and it results in the shortest message length. Devices with 7-bit and 10-bit addresses can be mixed in the same I<sup>2</sup>C-bus system regardless of whether it is a 0 to 100 kbit/s standard-mode system or a 0 to 400 kbit/s fast-mode system. Both existing and future masters can generate either 7-bit or 10-bit addresses.

### 12.0 FAST-MODE

In the fast-mode of the I<sup>2</sup>C-bus, the protocol, format, logic levels and maximum capacitive load for the SDA and SCL lines quoted in the previous I<sup>2</sup>C-bus specification are unchanged. Changes to the previous I<sup>2</sup>C-bus specification are:

- The maximum bit rate is increased to 400 kbit/s
- Timing of the serial data (SDA) and serial clock (SCL) signals has been adapted. There is no need for compatibility with other bus systems such as CBUS because they cannot operate at the increased bit rate
- The inputs of fast-mode devices must incorporate spike suppression and a Schmitt trigger at the SDA and SCL inputs
- The output buffers of fast-mode devices must incorporate slope control of the falling edges of the SDA and SCL signals
- If the power supply to a fast-mode device is switched off, the SDA and SCL I/O pins must be floating so that they don't obstruct the bus lines
- The external pull-up devices connected to the bus lines must be adapted to accommodate the shorter maximum

permissible rise time for the fast-mode I<sup>2</sup>C-bus. For bus loads up to 200 pF, the pull-up device for each bus line can be a resistor; for bus loads between 200 pF and 400 pF, the pull-up device can be a current source (3mA max.) or a switched resistor circuit as shown in Fig.37.

### 13.0 10-BIT ADDRESSING

The 10-bit addressing does not change the format in the I<sup>2</sup>C-bus specification. Using 10 bits for addressing exploits the reserved combination 1111XXX for the first seven bits of the first byte following a START (S) or repeated START (Sr) condition as explained in Section 9.1. The 10-bit addressing does not affect the existing 7-bit addressing.

Devices with 7-bit and 10-bit addresses can be connected to the same I<sup>2</sup>C-bus, and both 7-bit and 10-bit addressing can be used in a standard-mode system (up to 100 kbit/s) or a fast-mode system (up to 400 kbit/s).

Although there are eight possible combinations of the reserved address bits 1111XXX, only the four combinations 11110XX are used for 10-bit addressing. The remaining four combinations 11111XX are reserved for future I<sup>2</sup>C-bus enhancements.

#### 13.1 Definition of Bits in the First Two Bytes

The 10-bit slave address is formed from the first two bytes following a START condition (S) or a repeated START condition (Sr).

The first seven bits of the first byte are the combination 11110XX of which the last two bits (XX) are the two most-significant bits (MSBs) of the 10-bit address; the eighth bit of the first byte is the R/W bit that determines the direction of the message. A 'zero' in the least significant position of the first byte means that the master will write information to a selected slave. A 'one' in this position means that the master will read information from the slave.

If the R/W bit is 'zero', then the second byte contains the remaining 8 bits (XXXXXXXX) of the 10-bit address. If the R/W bit is 'one', then the next byte contains data transmitted from a slave to a master.

#### 13.2 Formats with 10-bit Addresses

Various combinations of read/write formats are possible within a transfer that includes 10-bit addressing. Possible data transfer formats are:

- **Master-transmitter transmits to slave-receiver with a 10-bit slave address. The transfer direction is not changed (Fig.29).** When a 10-bit

address follows a START condition, each slave compares the first seven bits of the first byte of the slave address (11110XX) with its own address and tests if the eighth bit (R/W direction bit) is 0. It is possible that more than one device will find a match and generate an acknowledge (A1). All slaves that found a match will compare the eight bits of the second byte of the slave address (XXXXXXXX) with their own addresses, but only one slave will find a match and generate an acknowledge (A2). The matching slave will remain addressed by the master until it receives a STOP condition (P) or a repeated START condition (Sr) followed by a different slave address

#### NOTES:

1. Combined formats can be used, for example, to control a serial memory. During the first data byte, the internal memory location has to be written. After the START condition and slave address is repeated, data can be transferred.
  2. All decisions on auto-increment or decrement of previously accessed memory locations etc. are taken by the designer of the device.
  3. Each byte is followed by an acknowledgement bit as indicated by the A or  $\bar{A}$  blocks in the sequence.
  4. I<sup>2</sup>C-bus compatible devices must reset their bus logic on receipt of a START or repeated START condition such that they all anticipate the sending of a slave address.
- **Master-receiver reads slave-transmitter with a 10-bit slave address. The transfer direction is changed after the second R/W bit (Fig.30).** Up to and including acknowledge bit A2, the procedure is the same as that described for a master-transmitter addressing a slave-receiver. After the repeated START condition (Sr), a matching slave remembers that it was addressed before. This slave then checks if the first seven bits of the first byte of the slave address following Sr are the same as they were after the START condition (S), and tests if the eighth (R/W) bit is 1. If there is a match, the slave considers that it has been addressed as a transmitter and generates acknowledge A3. The slave-transmitter remains addressed until it receives a STOP condition (P) or until it receives another repeated START condition (Sr) followed by a different slave address. After a repeated START condition (Sr), all the other slave devices will also compare the first seven bits of the first byte of the slave address (11110XX) with their own

# The I<sup>2</sup>C-bus and how to use it (including specification)

addresses and test the eighth (R/W) bit. However, none of them will be addressed because R/W = 1 (for 10-bit devices), or the 11110XX slave address (for 7-bit devices) does not match)

- **Combined format. A master transmits data to a slave and then reads data from the same slave (Fig.31).** The same master occupies the bus all the

time. The transfer direction is changed after the second R/W bit

- **Combined format. A master transmits data to one slave and then transmits data to another slave (Fig.32).** The same master occupies the bus all the time
- **Combined format. 10-bit and 7-bit addressing combined in one serial**

**transfer (Fig.33).** After each START condition (S), or each repeated START condition (Sr), a 10-bit or 7-bit slave address can be transmitted. Figure 33 shows how a master-transmits data to a slave with a 7-bit address and then transmits data to a second slave with a 10-bit address. The same master occupies the bus all the time.

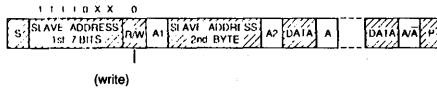

Figure 29. A Master-Transmitter Addresses a Slave-Receiver with a 10-Bit Address

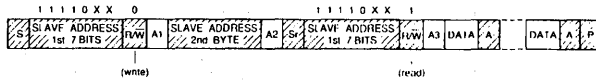

Figure 30. A Master-Receiver Addresses a Slave-Transmitter with a 10-Bit Address

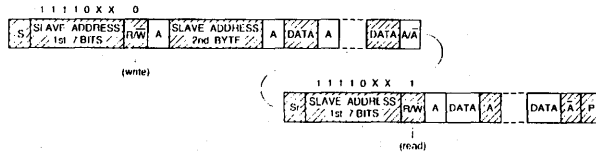

Figure 31. Combined Format. A Master Addresses a Slave with a 10-Bit Address, then Transmits Data to this Slave and Reads Data from this Slave

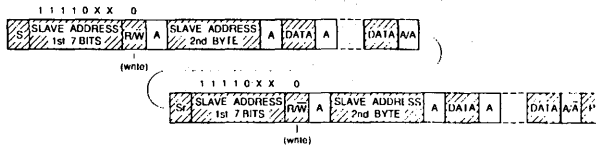

Figure 32. Combined Format. A Master Transmits Data to Two Slaves, Both With 10-Bit Addresses

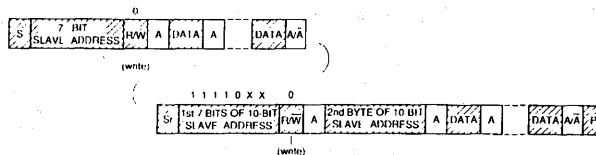

Figure 33. Combined Format. A Master Transmits Data to Two Slaves, One With a 7-Bit Address, and One with a 10-Bit Address.

# The I<sup>2</sup>C-bus and how to use it (including specification)

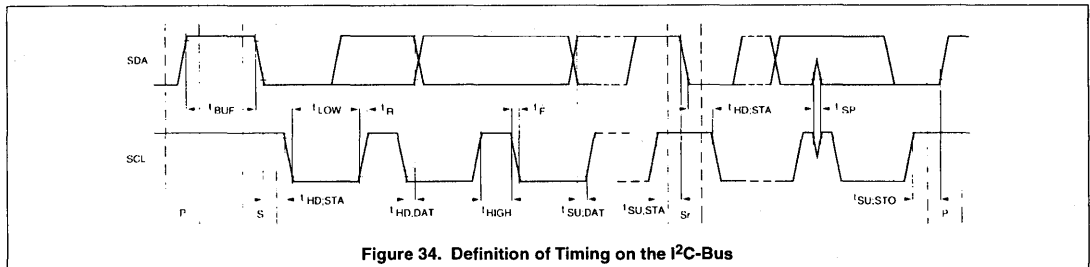

Figure 34. Definition of Timing on the I<sup>2</sup>C-Bus

Table 3. Characteristics of the SDA and SCL I/O Stages for I<sup>2</sup>C-Bus Devices

Parameter	Symbol	standard-mode devices		fast-mode devices		Unit
		Min.	Max.	Min.	Max.	
LOW level input voltage: fixed input levels V <sub>DD</sub> -related input levels	V <sub>IL</sub>	-0.5 -0.5	1.5 0.3V <sub>DD</sub>	-0.5 -0.5	1.5 0.3V <sub>DD</sub>	V
HIGH level input voltage: fixed input levels V <sub>DD</sub> -related input levels	V <sub>IH</sub>	3.0 0.7V <sub>DD</sub>	*1) *1)	3.0 0.7V <sub>DD</sub>	*1) *1)	V
Hysteresis of Schmitt trigger inputs: fixed input levels V <sub>DD</sub> -related input levels	V <sub>hys</sub>	n/a n/a	n/a n/a	0.2 0.05V <sub>DD</sub>	- -	V
Pulse width of spikes which must be suppressed by the input filter	t <sub>SP</sub>	n/a	n/a	0	50	ns
LOW level output voltage (open drain or open collector): at 3 mA sink current at 6 mA sink current	V <sub>OL1</sub> V <sub>OL2</sub>	0 n/a	0.4 n/a	0 0	0.4 0.6	V
Output fall time from V <sub>IH min.</sub> to V <sub>IL max.</sub> with a bus capacitance from 10 pF to 400 pF:	t <sub>OF</sub>		250 <sup>2)</sup> n/a	20 + 0.1C <sub>b</sub> <sup>2)</sup> 20 + 0.1C <sub>b</sub> <sup>2)</sup>	250 250 <sup>3)</sup>	ns
with up to 3 mA sink current at V <sub>OL1</sub>		-	250 <sup>2)</sup>	20 + 0.1C <sub>b</sub> <sup>2)</sup>	250	
with up to 6 mA sink current at V <sub>OL2</sub>		n/a	n/a	20 + 0.1C <sub>b</sub> <sup>2)</sup>	250 <sup>3)</sup>	
Input current each I/O pin with an input voltage between 0.4 V and 0.9V <sub>DD max.</sub>	I <sub>i</sub>	-10	10	\$10 <sup>3)</sup>	10 <sup>3)</sup>	μA
Capacitance for each I/O pin	C <sub>i</sub>	-	10	-	10	pF

**NOTES:**

n/a = not applicable

1. maximum V<sub>IH</sub> = V<sub>DD max.</sub> + 0.5 V

2. C<sub>b</sub> = capacitance of one bus line in pF. Note that the maximum t<sub>F</sub> for the SDA and SCL bus lines quoted in Table 4 (300 ns) is longer than the specified maximum t<sub>OF</sub> for the output stages (250 ns). This allows series protection resistors (R<sub>b</sub>) to be connected between the SDA/SCL pins and the SDA/SCL bus lines as shown in Fig.37 without exceeding the maximum specified t<sub>F</sub>.

3. I/O pins of fast-mode devices must not obstruct the SDA and SCL lines if V<sub>DD</sub> is switched off.

# The I<sup>2</sup>C-bus and how to use it (including specification)

## 14.0 GENERAL CALL ADDRESS AND START BYTE

The 10-bit addressing procedure for the I<sup>2</sup>C-bus is such that the first two bytes after the START condition (S) usually determine which slave will be selected by the master. The exception is the 'general call' address 00000000 (H'00'). Slave devices with 10-bit addressing will react to a 'general call' in the same way as slave devices with 7-bit addressing (see Section 9.1.1).

Hardware masters can transmit their 10-bit address after a 'general call'. In this case, the 'general call' address byte is followed by two successive bytes containing the 10-bit address of the master-transmitter. The format is as shown in Fig.17 where the first DATA byte contains the eight least-significant bits of the master address.

The START byte 00000001 (H'01') can precede the 10-bit addressing in the same way as for 7-bit addressing (see Section 9.1.2).

## 15.0 ELECTRICAL SPECIFICATIONS

The I/O levels, I/O current, spike suppression, output slope control and pin capacitance for I<sup>2</sup>C-bus devices are given in Table 3. The I<sup>2</sup>C-bus timing is given in Table 4. Figure 34 shows the timing definitions for the I<sup>2</sup>C-bus.

The noise margin for HIGH and LOW levels on the bus lines for fast-mode devices are the same as those specified in Section 10.0 for standard-mode I<sup>2</sup>C-bus devices.

The minimum HIGH and LOW periods of the SCL clock specified in Table 4 determine the maximum bit transfer rates of 100 kbit/s for standard-mode devices and 400 kbit/s for fast mode devices. Standard-mode and fast-mode I<sup>2</sup>C-bus devices must be able to follow transfers at their own maximum bit rates, either by being able to transmit or receive at that speed or by applying the clock synchronization procedure described in Section 7 which will force the master into a wait state and stretch the LOW period of the SCL signal. Of course, in the latter case the bit transfer rate is reduced.

## 16.0 APPLICATION INFORMATION

### 16.1 Slope-Controlled Output Stages of Fast-Mode I<sup>2</sup>C-Bus Devices

The electrical specifications for the I/Os of

I<sup>2</sup>C-bus devices and the characteristics of the bus lines connected to them are given in Tables 3 and 4 in Section 15.

Figures 35 and 36 show examples of output stages with slope control in CMOS and bipolar technology. The slope of the falling edge is defined by a Miller capacitor (C1) and a resistor (R1). The typical values for C1 and R1 are indicated on the diagrams. The wide tolerance for output fall time  $t_{OF}$  given in Table 3 means that the design is not critical. The fall time is only slightly influenced by the external bus load ( $C_b$ ) and external pull-up resistor ( $R_p$ ). However, the rise time ( $t_R$ ) specified in Table 4 is mainly determined by the bus load capacitance and the value of the pull-up resistor.

### 16.2 Switched Pull-Up Circuit for Fast-Mode I<sup>2</sup>C-Bus Devices

The supply voltage ( $V_{DD}$ ) and the maximum output LOW level determine the minimum value of pull-up resistor  $R_p$  (see Section 10.1). For example, with a supply voltage of  $V_{DD} = 5V \pm 10\%$  and  $V_{OLmax} = 0.4V$  at 3 mA,  $R_{pmin} = (5.5 - 0.4)/0.003 = 1.7 k\Omega$ . As shown in Fig.38, this value of  $R_p$  limits the maximum bus capacitance to about 200 pF to meet the maximum  $t_R$  requirement of 300 ns. If the bus has a higher capacitance than this, a switched pull-up circuit as shown in Fig.37 can be used.

The switched pull-up circuit in Fig.37 is for a supply voltage of  $V_{DD} = 5V \pm 10\%$  and a maximum capacitive load of 400 pF. Since it is controlled by the bus levels, it needs no additional switching control signals. During the rising/falling edges, the bilateral switch in the HCT4066 switches pull-up resistor  $R_{p2}$  on/off at bus levels between 0.8 V and 2.0 V. Combined resistors  $R_{p1}$  and  $R_{p2}$  can pull-up the bus line within the maximum specified rise time ( $t_R$ ) of 300 ns. The maximum sink current for the driving I<sup>2</sup>C-bus device will not exceed 6 mA at  $V_{OL2} = 0.6V$ , or 3 mA at  $V_{OL1} = 0.4V$ .

Series resistors  $R_s$  are optional. They protect the I/O stages of the I<sup>2</sup>C-bus devices from high-voltage spikes on the bus lines, and minimize crosstalk and undershoot of the bus line signals. The maximum value of  $R_s$  is determined by the maximum permitted voltage drop across this resistor when the bus line is switched to the LOW level in order to switch off  $R_{p2}$ .

### 16.3 Wiring Pattern of the Bus Lines

In general, the wiring must be so chosen that crosstalk and interference to/from the bus lines is minimized. The bus lines are most susceptible to crosstalk and interference at the HIGH level because of the relatively high impedance of the pull-up devices.

If the length of the bus lines on a PCB or ribbon cable exceeds 10 cm and includes the  $V_{DD}$  and  $V_{SS}$  lines, the wiring pattern must be:

SDA \_\_\_\_\_  
 $V_{DD}$  \_\_\_\_\_  
 $V_{SS}$  \_\_\_\_\_  
 SCL \_\_\_\_\_

If only the  $V_{SS}$  line is included, the wiring pattern must be:

SDA \_\_\_\_\_  
 $V_{SS}$  \_\_\_\_\_  
 SCL \_\_\_\_\_

These wiring patterns also result in identical capacitive loads for the SDA and SCL lines. The  $V_{SS}$  and  $V_{DD}$  lines can be omitted if a PCB with a  $V_{SS}$  and/or  $V_{DD}$  layer is used.

If the bus lines are twisted-pairs, each bus line must be twisted with a  $V_{SS}$  return. Alternatively, the SCL line can be twisted with a  $V_{SS}$  return, and the SDA line twisted with a  $V_{DD}$  return. In the latter case, capacitors must be used to decouple the  $V_{DD}$  line to the  $V_{SS}$  line at both ends of the twisted pairs.

If the bus lines are shielded (shield connected to  $V_{SS}$ ), interference will be minimized. However, the shielded cable must have low capacitive coupling between the SDA and SCL lines to minimize crosstalk.

### 16.4 Maximum and Minimum Values of Resistors $R_p$ and $R_s$ for Fast-Mode I<sup>2</sup>C-Bus Devices

The maximum and minimum values for resistors  $R_p$  and  $R_s$  connected to a fast-mode I<sup>2</sup>C-bus can be determined from Fig.25, 26 and 28 in Section 10.1. Because a fast-mode I<sup>2</sup>C-bus has faster rise times ( $t_R$ ) the maximum value of  $R_p$  as a function of bus capacitance is less than that shown in Fig.27. The replacement graph for Fig.27 showing the maximum value of  $R_p$  as a function of bus capacitance ( $C_b$ ) for a fast mode I<sup>2</sup>C-bus is given in Fig.38.

# The I<sup>2</sup>C-bus and how to use it (including specification)

**Table 4. Characteristics of the SDA and SCL Bus Lines for I<sup>2</sup>C-Bus Devices**

Parameter	Symbol	Standard-mode I <sup>2</sup> C-bus		Fast-mode I <sup>2</sup> C-bus		Unit
		Min.	Max.	Min.	Max.	
SCL clock frequency	f <sub>SCL</sub>	0	100	0	400	kHz
Bus free time between a STOP and START condition	t <sub>BUF</sub>	4.7	-	1.3	-	μs
Hold time (repeated) START condition. After this period, the first clock pulse is generated	t <sub>HD;STA</sub>	4.0	-	0.6	-	μs
LOW period of the SCL clock	t <sub>LOW</sub>	4.7	-	1.3	-	μs
HIGH period of the SCL clock	t <sub>HIGH</sub>	4.0	-	0.6	-	μs
Set-up time for a repeated START condition	t <sub>SU;STA</sub>	4.7	-	0.6	-	μs
Data hold time: for CBUS compatible masters (see NOTE, Section 9.1.3) for I <sup>2</sup> C-bus devices	t <sub>HD;DAT</sub>	5.0 0 <sup>1)</sup>	- -	- 0 <sup>1)</sup>	- 0.9 <sup>2)</sup>	μs μs
Data set-up time	t <sub>SU;DAT</sub>	250	-	100 <sup>3)</sup>	-	ns
Rise time of both SDA and SCL signals	t <sub>R</sub>	-	1000	20 + 0.1C <sub>b</sub> <sup>4)</sup>	300	ns
Fall time of both SDA and SCL signals	t <sub>F</sub>	-	300	20 + 0.1C <sub>b</sub> <sup>4)</sup>	300	ns
Set-up time for STOP condition	t <sub>SU;STO</sub>	4.0	-	0.6	-	μs
Capacitive load for each bus line	C <sub>b</sub>	-	400	-	400	pF

**NOTES:**

All values referred to V<sub>IH min.</sub> and V<sub>IL max.</sub> levels (see Table 3).

1. A device must internally provide a hold time of at least 300 ns for the SDA signal (referred to the V<sub>IH min.</sub> of the SCL signal) in order to bridge the undefined region of the falling edge of SCL.
2. The maximum t<sub>HD;DAT</sub> has only to be met if the device does not stretch the LOW period (t<sub>LOW</sub>) of the SCL signal.
3. A fast-mode I<sup>2</sup>C-bus device can be used in a standard-mode I<sup>2</sup>C-bus system, but the requirement t<sub>SU;DAT</sub> ≥ 250 ns must then be met. This will automatically be the case if the device does not stretch the LOW period of the SCL signal. If such a device does stretch the LOW period of the SCL signal, it must output the next data bit to the SDA line t<sub>R max.</sub> + t<sub>SU;DAT</sub> = 1000 + 250 = 1250 ns (according to the standard-mode I<sup>2</sup>C-bus specification) before the SCL line is released.
4. C<sub>b</sub> = total capacitance of one bus line in pF.

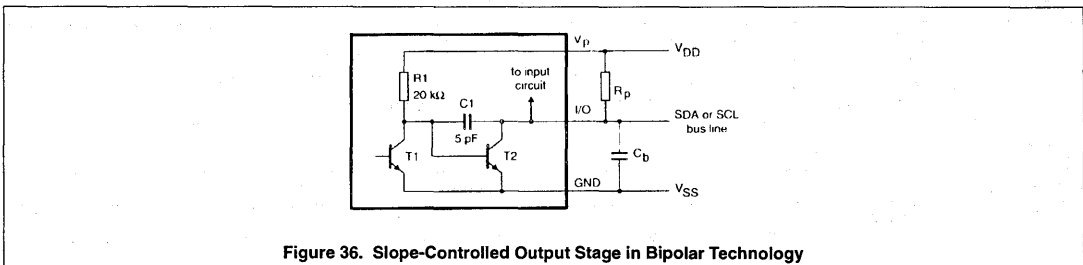
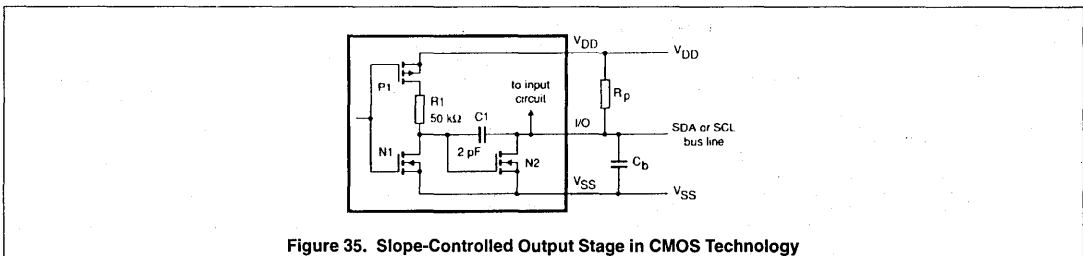

# The I<sup>2</sup>C-bus and how to use it (including specification)

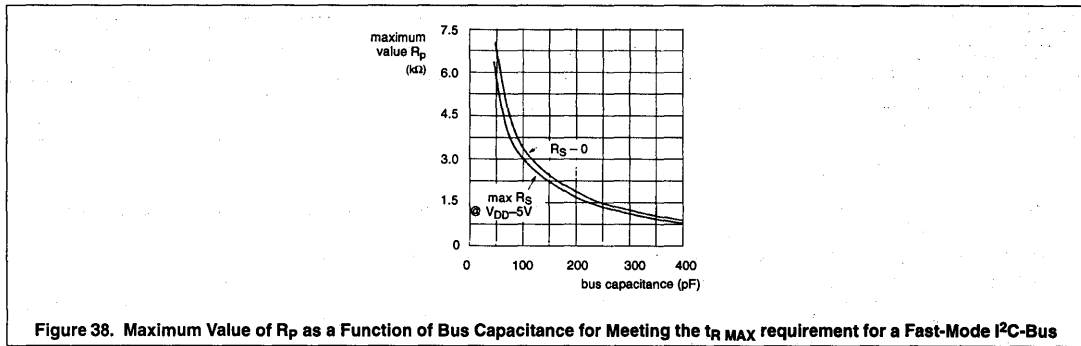
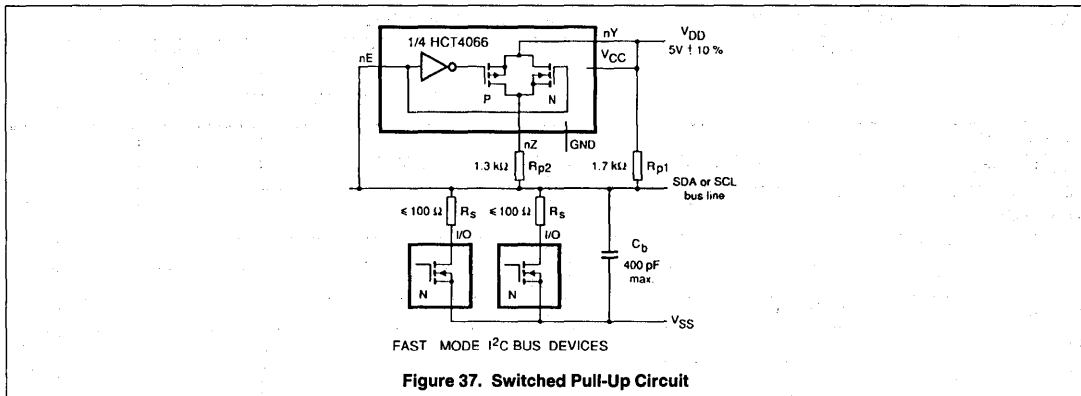

## 17.0 DEVELOPMENT TOOLS

### 17.1 Development tools for 8048 and 8051-based systems

Product	Description
OM1016	I <sup>2</sup> C-bus demonstration board with microcontroller, LCD, LED, Par. I/O, SRAM, EEPROM, Clock, DTMF generator, AD/DA conversion, infrared link.
OM1018	manual for OM1016
OM1020	LCD and driver demonstration board
OM4151	I <sup>2</sup> C-bus evaluation board (similar to OM1016 above but without infrared link).

### 17.2 Development tools for 68000-based systems

Product	Description
OM4160	Microcore-1 demonstration/evaluation board: SCC68070, 128K EPROM, 512K DRAM, I <sup>2</sup> C, RS-232C, VSC SCC66470, resident monitor
OM4160/3	Microcore-3 demonstration/evaluation board: 93C110, 128K EPROM, 64K SRAM, I <sup>2</sup> C, RS-232C, 40 I/O, resident monitor

### 17.3 Development tools for all systems

Product	Description
OM1022	I <sup>2</sup> C-bus analyzer. Hardware and software (runs on IBM or compatible PC) to experiment with and analyze the behaviour of the I <sup>2</sup> C-bus (includes documentation)



# The I<sup>2</sup>C-bus and how to use it (including specification)

## 18.0 SUPPORT LITERATURE

<b>Data handbooks</b>
IC01 1992: Semiconductors for radio and audio systems
IC02 1992: Semiconductors for television and video systems
IC03 1993: Semiconductors for telecom systems
IC14 1992: 8048-based 8-bit microcontrollers
IC20 1994: 8051-based 8-bit microcontrollers
<b>Brochures/leaflets</b>
Microcontrollers and microprocessors for embedded control applications
I <sup>2</sup> C-bus compatible ICs and support overview
I <sup>2</sup> C-bus control programs for consumer applications

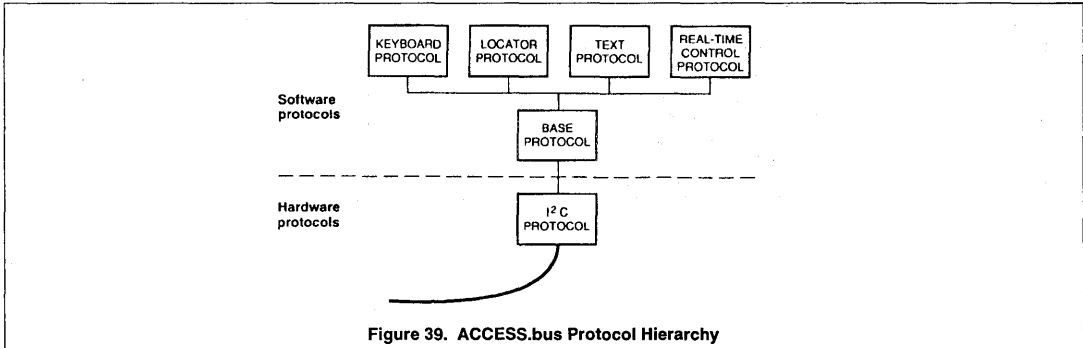

Figure 39. ACCESS.bus Protocol Hierarchy

### 19.0 APPLICATION OF THE I<sup>2</sup>C-BUS IN THE ACCESS.bus SYSTEM

The ACCESS.bus (bus for connecting ACCESSory devices to a host system) is an I<sup>2</sup>C-bus based open-standard serial interconnect system jointly developed and defined by Philips Semiconductors and Digital Equipment Corporation. It is a lower-cost alternative to an RS-232C interface for connecting up to 14 inputs/outputs from peripheral equipment to a desk-top computer or workstation over a distance of up to eight metres. The peripheral equipment can be relatively low speed items such as keyboards, hand-held image scanners, cursor positioners, bar-code readers, digitizing tablets, card readers or modems.

All that's required to implement an ACCESS.bus is an 8051-family

microcontroller with an I<sup>2</sup>C-bus interface, and a 4-wire cable carrying a serial data (SDA) line, a serial clock (SCL) line, a ground wire and a 12 V supply line (500 mA max.) for powering the peripherals.

Important features of the ACCESS.bus are that the bit rate is only about 20% less than the maximum bit rate of the I<sup>2</sup>C-bus, and the peripherals don't need separate device drivers. Also, the protocol allows the peripherals to be changed by 'hot-plugging' without re-booting.

As shown in Fig.39, the ACCESS.bus protocol comprises three levels: the I<sup>2</sup>C-bus protocol, the base protocol, and the application protocol.

The base protocol is common to all ACCESS.bus devices and defines the format of the ACCESS.bus message. Unlike the I<sup>2</sup>C-bus protocol, it restricts masters to sending and slaves to receiving data. One

item of appended information is a checksum for reliability control. The base protocol also specifies seven types of control and status messages which are used in the system configuration which assigns unique addresses to the peripherals without the need for setting jumpers or switches on the devices.

The application protocol defines the message semantics that are specific to the three categories of peripheral device (keyboards, cursor locators, and text devices which generate character streams e.g. card readers) which are at present envisaged.

Philips Semiconductors offers computer peripheral equipment manufacturers technical support, a wide range of I<sup>2</sup>C-bus devices and development kits for the ACCESS.bus. Hardware, software and marketing support is also offered by DEC.

## I<sup>2</sup>C bus addresses

### ASSIGNED I<sup>2</sup>C BUS ADDRESSES

PART NUMBER	FUNCTION	I <sup>2</sup> C ADDRESS						
		A6	A5	A4	A3	A2	A1	A0
—	General call address	0	0	0	0	0	0	0
—	Reserved addresses	0	0	0	0	X	X	X
PCF8574	I <sup>2</sup> C bus to 8-bit bus converter	0	1	0	0	A	A	A
PCF8574A	I <sup>2</sup> C bus to 8-bit bus converter	0	1	1	1	A	A	A
SAA5252	Closed caption decoder	0	0	1	0	1	0	0
SAA7110	One chip front end	1	0	0	1	1	1	A
SAA7188A	Digital video encoder	1	0	0	0	1	A	0
SAA7151B	Digital multistandard colour decoder with SCART interface	1	0	0	0	1	A	1
SAA7152	Digital combination filter	1	0	1	1	0	0	1
SAA7194 (7196)	Digital video decoder and scaler circuit (DESC)	0	1	0	0	0	0	A
SAA7191B	S-VHS digital multistandard decoder "square pixel"	1	0	0	0	1	A	1
SAA7192A	Digital color space converter	1	1	1	0	0	0	A
SAA7199	Digital encoder	1	0	1	1	0	0	0
SAA9042	Teletext decoder	0	0	1	0	0	0	1
SAA9051	Digital multi-standard TV decoder	1	0	0	0	1	0	1
TDA4670	Picture signal improvement circuit	1	0	0	0	1	0	0
TDA4680/4686	Video processor	1	0	0	0	1	0	0
TDA8440	Switch for CTV receivers	1	0	0	1	A	A	A
TDA8442	Interface for color decoders	1	0	0	0	1	0	0
TDA8443	YUV/RGB interface circuit	1	1	0	1	A	A	A
TDA8444	Octuple 6-bit DAC	0	1	0	0	A	A	A
TDA9141	PAL/NTSC/SECAM decoder/sync processor	1	0	0	0	1	A	1

X = Don't care.

A = Can be connected high or low by the user.

# I<sup>2</sup>C parallel printer port adaptor

The schematic below shows how Philips I<sup>2</sup>C software programs are able to communicate through any IBM-compatible PC parallel printer port using I<sup>2</sup>C serial protocol. The software toggles the SDA and SCL lines in a

manner compatible with all I<sup>2</sup>C integrated circuits and I<sup>2</sup>C evaluation boards such as DTV7191 and DTV9051. Some variations of the four-wire I<sup>2</sup>C bus pinning have changed the order of the clock, data power and

ground. Check the pinning required for each evaluation board connected using this type of interface. Power for the interface board must come from the application, not the PC printer port.

## I<sup>2</sup>C PARALLEL PRINTER PORT ADAPTOR

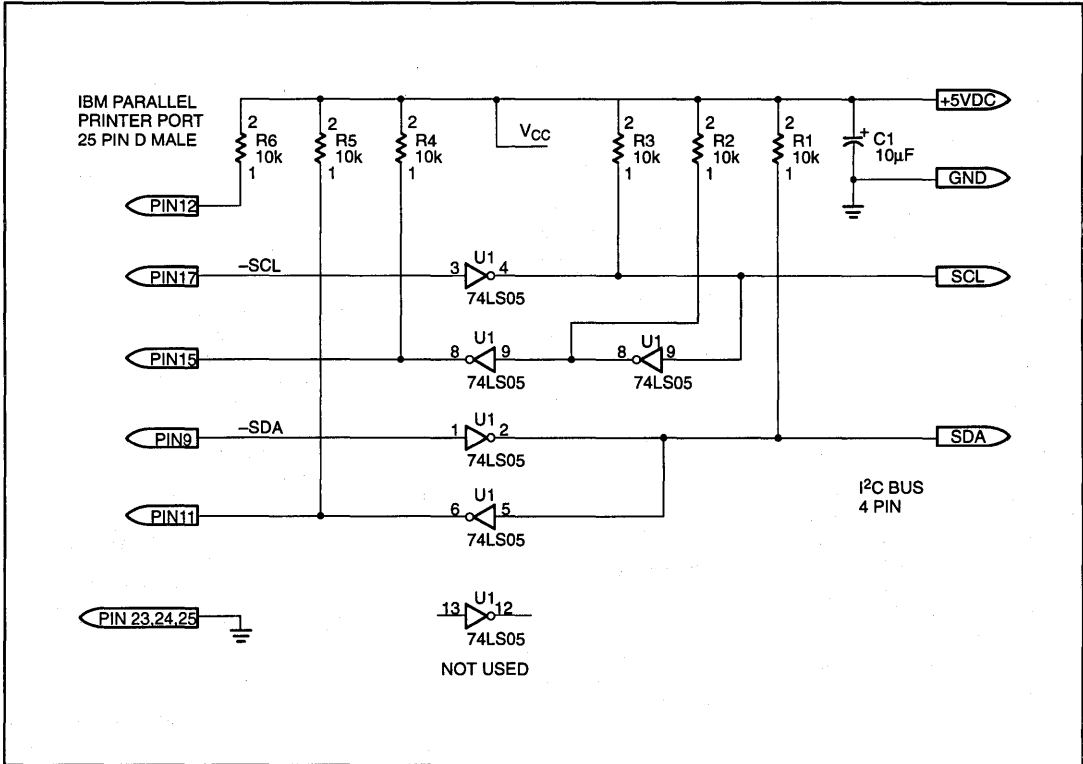

# Interfacing the PCF8584 I<sup>2</sup>C-bus controller to 80C51 family microcontrollers

AN425

## DESCRIPTION

This application note shows how to use the PCF8584 I<sup>2</sup>C-bus controller with 80C51 family microcontrollers. One typical way of connecting the PCF8584 to an 80C31 is shown. Some basic software routines are described showing how to transmit and receive bytes in a single master system. An example is given of how to use these routines in an application that makes use of the I<sup>2</sup>C circuits on an I<sup>2</sup>C demonstration board.

The PCF8584 is used to interface between parallel microprocessor or microcontroller buses and the serial I<sup>2</sup>C bus. For a description of the I<sup>2</sup>C bus protocol refer to the I<sup>2</sup>C bus specification which is printed in the microcontroller user guide.

The PCF8584 controls the transmission and reception of data on the I<sup>2</sup>C bus, arbitration, clock speeds and transmission and reception of data on the parallel bus. The parallel bus is compatible with 80C51, 68000, 8085 and Z80 buses. Communication with the I<sup>2</sup>C-bus can be done on an interrupt or polled basis. This application note focuses on interfacing with 8051 microcontrollers in single master systems.

## PCF8584

In Figure 1, a block diagram is shown of the PCF8584. Basically it consists of an I<sup>2</sup>C-interface similar to the one used in 84Cxx family microcontrollers, and a control block for interfacing to the microcontroller.

The control block can automatically determine whether the control signals are from 80xx or 68xxx type of microcontrollers.

This is determined after the first write action from the microcontroller to the PCD-8584. The control block also contains a programmable divider which allows the selection of different PCF8584 and I<sup>2</sup>C clocks.

The I<sup>2</sup>C interface contains several registers which can be written and read by the microcontroller.

S1 is the control/status register. This register is accessed while the A0 input is 1. The meaning of the bits depends on whether the register is written to or read from. When used

as a single master system the following bits are important:

**PIN:** Interrupt bit. This bit is made active when a byte is sent/received to/from the I<sup>2</sup>C-bus. When ENI is made active, PIN also controls the external INT line to interrupt the microcontroller.

**ES0-ES2:** These bits are used as pointer for addressing S0, S0', S2 and S3. Setting ES0 also enables the Serial I/O.

**ENI:** Enable Interrupt bit. Setting this bit enables the generation of interrupts on the INT line.

**STA, STO:** These bits allow the generation of START or STOP conditions.

**ACK:** With this bit set and the PCF8584 is in master/receiver mode, no acknowledge is generated by the PCF8584. The slave/transmitter now knows that no more data must be sent to the I<sup>2</sup>C-bus.

**BER:** This bit may be read to check if bus errors have occurred.

**BB:** This bit may be read to check whether the bus is free for I<sup>2</sup>C-bus transmission.

S2 is the clock register. It is addressed when A0 = 0 and ES0-ES2 = 010 in the previous write cycle to S1. With the bits S24-S20 it is possible to select 5 input clock frequencies and 4 I<sup>2</sup>C clock frequencies.

S3 is the interrupt vector register. It is addressed when A0 = 0 and ES0-ES2 = 001 in the previous write cycle to S1. This register is not used when an 80C51 family microcontroller is used. An 80C51 microcontroller has fixed interrupt vector addresses.

S0' is the own address register. It is addressed when A0 = 0 and ES0-ES2 = 000. This register contains the slave address of the PCF8584. In the single master system described here, this register has no functional use. However, by writing a value to S0', the PCF8584 determines whether an 80Cxx or 68xxx type microcontroller is the controlling microcontroller by looking at the CS and WR lines. So independent of whether the PCF8584 is used as master or slave, the

microcontroller should always first write a value to S0' after reset.

S0 is the I<sup>2</sup>C data register. It is addressed when A0 = 0 and ES0-ES2 = 1x0. Transmission of a byte on the I<sup>2</sup>C bus is done by writing this byte to S0. When the transmission is finished, the PIN bit in S1 is reset and if ENI is set, an interrupt will be generated. Reception of a byte is signaled by resetting PIN and by generating an interrupt if ENI is set. The received byte can be read from S0.

The SDA and SCL lines have no protection diodes to V<sub>DD</sub>. This is important for multi-master systems. A system with a PCF8584 can now be switched off without causing the I<sup>2</sup>C-bus to hang-up. Other masters still can use the bus.

For more information of the PCF8584 refer to the data sheet.

## PCF8584/8031 Hardware Interface

Figure 2 shows a minimum system with an 8051 family controller and a PCF8584. In this example, an 80C31 is used. However any 80C51 family controller with external addressing capability can be used.

The software resides in EPROM U3. For addressing this device, latch U2 is necessary to demultiplex the lower address bits from the data bits. The PCF8584 is mapped in the external data memory area. It is selected when A1 = 0. Because in this example no external RAM or other mapped peripherals are used, no extra address decoding components are necessary. A0 is used by the PCF8584 for proper register selection in the PCF8584.

U5A is an inverter with Schmitt trigger input and is used to buffer the oscillator signal of the microcontroller. Without buffering, the rise and fall time specifications of the CLK signal are not met. It is also important that the CLK signal has a duty cycle of 50%. If this is not possible with certain resonators or microcontrollers, then an extra flip-flop may be necessary to obtain the correct duty cycle.

U5C and U5D are used to generate the proper reset signals for the microcontroller and the PCF8584.

# Interfacing the PCF8584 I<sup>2</sup>C-bus controller to 80C51 family microcontrollers

AN425

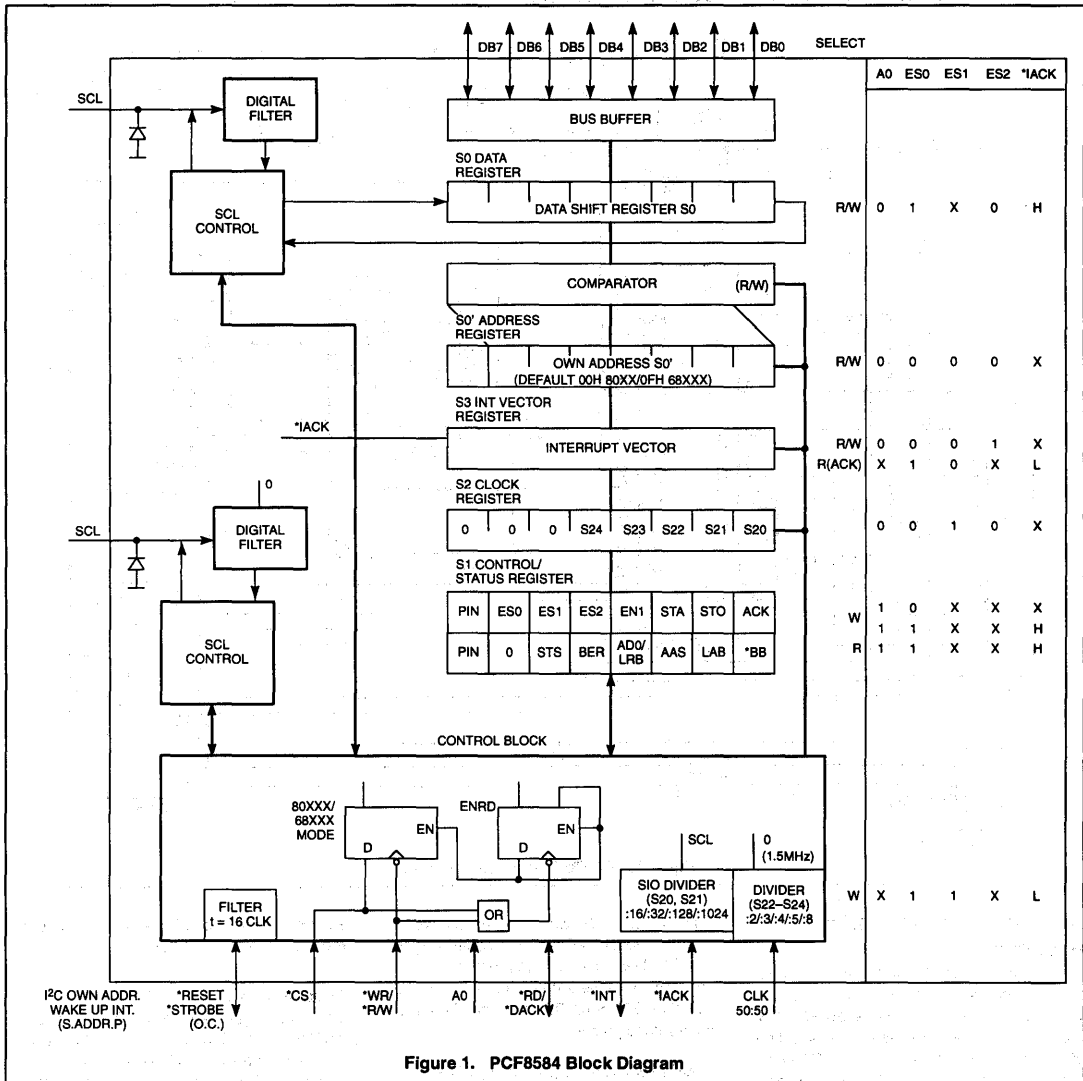



# Interfacing the PCF8584 I<sup>2</sup>C-bus controller to 80C51 family microcontrollers

AN425

Then the status register of PCF8584 must be read to check if the I<sup>2</sup>C bus is free. First the status register must be addressed by giving ES0–ES2 of the control register the correct value (lines 47–48). Then the Bus Busy bit is tested until the bus is free (lines 49–50). If this is the case, the slave address is sent to data register S0 and the I<sup>2</sup>C\_END bit is cleared (lines 51–53). The slave address is set by the user program in variable USER. The LSB of the slave address is the R/W bit. I<sup>2</sup>C\_END can be tested by the user program whether an I<sup>2</sup>C reception/transmission is in progress or not.

Next the START condition will be generated and interrupt generation enabled by setting the appropriate bits in control register S1. (lines 54–55).

Now the routine will return back to the user program and other tasks may be performed. When the START condition, slave address and R/W bit are sent, and the ACK is received, the PCF8584 will generate an interrupt. The interrupt routine will determine if more bytes have to be received or transmitted.

## Routine Stop (Lines 59–62) —

Calling this routine, a STOP condition will be sent to the I<sup>2</sup>C bus. This is done by sending the correct value to control register S1 (lines 59–61). After this the I<sup>2</sup>C\_END bit is set, to indicate to the user program that a complete I<sup>2</sup>C sequence has been received or transmitted.

## Routine I<sup>2</sup>C\_Init (Lines 65–76)—

This routine initializes the PCF8584. This must be done directly after reset. Lines 67–70 write data to 'own address' register S0'. First the correct address of S0' is set in control register S1 (lines 67–68), then the correct value is written to it (lines 69–70). The value for S0' is in variable SLAVE\_ADR and set by the user program. As noted previously, register S0' must always be the first register to be accessed after reset, because the PCF8584 now determines whether an 80Cxxx or 68xxx microcontroller is connected. Lines 72–76 set the clock register S2. The variable I<sup>2</sup>C\_CLOCK is also set by the user program.

## Module INTERR

This module contains the I<sup>2</sup>C interrupt routine. This routine is called every time a byte is received or transmitted on the I<sup>2</sup>C bus. In lines 12–15 RAM space for variables is reserved.

BASE is the start address in the internal 80C51 RAM where the data is stored that is received, or where the data is stored that has

to be transmitted.

NR\_BYTES, IIC\_CNT and SLAVE were explained earlier. I<sup>2</sup>C\_END and DIR are flags that are used in the program. I<sup>2</sup>C\_END indicates whether an I<sup>2</sup>C transmission or reception is in progress. DIR indicates whether the PCF8584 has to receive or transmit bytes. The interrupt routine makes use of register bank 1.

The transmission part of the routine starts at line 42. In lines 42–43, a check is made whether IIC\_CNT = NR\_BYTES. If true, all bytes are sent and a STOP condition may be generated (lines 44–45).

Next the pointer for the internal RAM is restored (line 46) and the byte to be transmitted is fetched from the internal RAM (line 47). Then this byte is sent to the PCF8584 and the variables are updated (lines 47–49). The interrupt routine is left and the user program may proceed. The receive part starts from line 55. First a check is made if the next byte to be received is the last byte (lines 56–59). If true the ACK must be disabled when the last byte is received. This is accomplished by resetting the ACK bit in the control register S1 (lines 60–61).

Next the received byte may be read (line 62) from data register S0. The byte will be temporary stored in R4 (line 63). Then a check is made if this interrupt was the first after a START condition. If so, the byte read has no meaning and the interrupt routine will be left (lines 68–70). However by reading the data register S0 the next read cycle is started.

If valid data is received, it will be stored in the internal RAM addressed by the value of BASE (lines 71–73). Finally a check is made if all bytes are received. If true, a STOP condition will be sent (lines 75–78).

## EXAMPLES

In the listing section (starting on page 8), some examples are shown that make use of the routines described before. The examples are transmission of a sequence, reception of I<sup>2</sup>C data and an example that combines both.

The first example sends bytes to the PCD 8577 LCD driver on the OM1016 demonstration board. Lines 7 to 10 define the interface with the other modules and should be included in every user program. Lines 14 to 16 define the segments in the user module. It is completely up to the user how to organize this.

Lines 24 and 28 are the reset and interrupt vectors. The actual user program starts at line 33. Here three variables are defined that

are used in the I<sup>2</sup>C driver routines. Note that PCF8584 must be an even address, otherwise the wrong internal registers will be accessed! Lines 37–42 initialize the interrupt logic of the microcontroller. Next the PCF8584 will be initialized (line 45).

The PCF8584 is now ready to transmit data. A table is made in the routine at line 61. For the PCD8577, the data is a control byte and the segment data. Note that the table does not contain the slave address of the LCD driver. In lines 51–54, variables are made ready to start the transmission. This consists of defining the direction of the transmission (DIR), the address where the data table starts (BASE), the number of bytes to transmit (NR\_BYTES, without slave address) and the slave address (SLAVE) of the I<sup>2</sup>C peripheral that has to be accessed.

In line 55 the transmission is started. Once the I<sup>2</sup>C transmission is started, the user program can do other tasks because the transmission works on interrupts. In this example a loop is performed (line 58). The user can check the end of the transmission during the other tasks, by testing the I<sup>2</sup>C\_END bit regularly.

The second example program receives 2 bytes from the PCF8574P I/O expander on the OM1016 demonstration board. Until line 45 the program is identical to the transmit routine because it consists of initialization and variable definition. From line 48, the variables are set for I<sup>2</sup>C reception. The received bytes are stored in RAM area from label TABLE. During reception, the user program can do other tasks. By testing the I<sup>2</sup>C\_END bit the user can determine when to start processing the data in the TABLE.

The third example program displays time from the PCF8583P clock/calendar/RAM on the LCD display driven by the PCF8577. The LED display (driven by SAA1064) shows the value of the analog inputs of the A/D converter PCF8591. The four analog inputs are scanned consecutively.

In this example, both transmit and receive sequences are implemented as shown in the previous examples. The main clock part is from lines 62–128. This contains the calls to the I<sup>2</sup>C routines. From lines 135–160, routines are shown that prepare the data to be transmitted. Lines 171 to 232 are the main program for the AD converter and LED display. Lines 239 to 340 contain routines used by the main program. This demo program can also be used with the I<sup>2</sup>C peripherals on the OM1016 demonstration board.

# Interfacing the PCF8584 I<sup>2</sup>C-bus controller to 80C51 family microcontrollers

AN425

ASM51 TSW ASSEMBLER Routines for PCF8584

```

LOC  OBJ          LINE  SOURCE
                                     1  $TITLE (Routines for PCF8584)
                                     2  $PAGELENGTH(40)
                                     3  ;Program written for PCF8584 as master
                                     4  ;
                                     5      PUBLIC READBYTE,READCONTR,SENDBYTE
                                     6      PUBLIC SENDCONTR,START,STOP
                                     7      PUBLIC I2C_INIT
                                     8      EXTRN BIT(I2C_END,DIR)
                                     9      EXTRN DATA(SLAVE,IIC_CNT,NR_BYTES)
                                     10     EXTRN NUMBER(SLAVE_ADR,I2C_CLOCK,PCF8584)
                                     11     ;
                                     12     ;Define code segment
----- 13     ROUTINE  SEGMENT CODE
                                     14     RSEG    ROUTINE
                                     15     ;
                                     16     ;SENDBYTE sends a byte to PCF8584 with A0=0
0000:   R          17     SENDBYTE:
0000: 900000   R          18         MOV DPTR,#PCF8584 ;Register address
0003: F0          19     SEND:  MOVX @DPTR,A    ;Send byte
0004: 22          20         RET
                                     21     ;
                                     22     ;SENDCONTR sends a byte to PCF8584 with A0=1
0005:   R          23     ;Byte to be send must be in accu
0005: 900001   R          24     SENDCONTR:
0005: 900001   R          25         MOV DPTR,#PCF8584+01H ;Register address
0008: 80F9          26         JMP SEND
                                     27     ;
000A:   R          28     ;READBYTE reads a byte from PCF8584 with A0=0
000A: 900000   R          29     ;Received byte is stored in accu
000A: E0          30     READBYTE:
000A: E0          31         MOV DPTR,#PCF8584 ;Register address
000D: E0          32     REC:  MOVX A,@DPTR    ;Receive byte
000E: 22          33         RET
                                     34     ;
000F:   R          35     ;READCONTR reads a byte from PCF8584 with A0=1
000F: 900001   R          36     ;Received byte is stored in accu
000F: 900001   R          37     READCONTR:
000F: 900001   R          38         MOV DPTR,#PCF8584+01H ;Register address
0012: 80F9          39         JMP REC
                                     40     ;
0014: 750000   R          41     ;START tests if the I2C bus is ready. If ready a
0014: 750000   R          42     ;START-condition will be sent, interrupt generation
0014: 750000   R          43     ;and acknowledge will be enabled.
0014: 750000   R          44     START: MOV IIC_CNT,#00 ;Clear I2C byte counter
0017: 200002   R          45         JB DIR,PROCEED ;If DIR is 'receive' then
001A: 0500          46         INC NR_BYTES ;increment NR_BYTES
001C: 7440          47     PROCEED:MOV A,#40H    ; Read STATUS register of
                                     ; 8584
001E: 120005   R          48         CALL SENDCONTR
0021: 12000F   R          49     TESTBB: CALL READCONTR
0024: 30E0FA          50         JNB ACC.0,TESTBB; Test BB/ bit
0027: E500          51         MOV A,SLAVE
0029: C200          52         CLR I2C_END    ;Reset I2C ready bit
002B: 120000   R          53         CALL SENDBYTE ;Send slave address
002E: 744D          54         MOV A,#01001101B;Generate START, set ENI,
                                     ;set ACK

```



# Interfacing the PCF8584 I<sup>2</sup>C-bus controller to 80C51 family microcontrollers

AN425

```

0030: 120005 R 55      CALL SENDCONTR
0033: 22      56      RET
      57      ;
      58      ;STOP will generate a STOP condition and set the
      ;I2C_END bit
0034: 74C3     59      STOP:  MOV A,#11000011B
0036: 120005 R 60      CALL SENDCONTR ;Send STOP condition
0039: D200     R 61      SETB I2C_END  ;Set I2C_END bit
003B: 22      62      RET
      63      ;
      64      ;I2C_init does the initialisation of the PCF8584
003C:      65      I2C_INIT:
      66      ;Write own slave address
003C: E4      67      CLR A
003D: 120005 R 68      CALL SENDCONTR ;Write to control register
0040: 7400     R 69      MOV A,#SLAVE_ADR
0042: 120000 R 70      CALL SENDBYTE  ;Write to own slave
      ;register
      71      ;Write clock register
0045: 7420     72      MOV A,#20H
0047: 120005 R 73      CALL SENDCONTR ;Write to control register
004A: 7400     R 74      MOV A,#I2C_CLOCK
004C: 120000 R 75      CALL SENDBYTE  ;Write to clock register
004F: 22      76      RET
      77      ;
0050:      78      END

```

# Interfacing the PCF8584 I<sup>2</sup>C-bus controller to 80C51 family microcontrollers

AN425

```

ASM51 TSW ASSEMBLER I2C INTERRUPT ROUTINE

LOC OBJ LINE SOURCE
1 $TITLE (I2C INTERRUPT ROUTINE)
2 $PAGELENGTH(40)
3 ;
4 PUBLIC INT0_SRV
5 PUBLIC DIR,I2C_END
6 PUBLIC BASE,NR_BYTES,IIC_CNT,SLAVE
7 EXTRN CODE(SENDBYTE,SENDCONTR,STOP)
8 EXTRN CODE(READBYTE,READCONTR)
8 ;
9 ;Define variables in RAM
10 IIC_VAR SEGMENT DATA
----
11 RSEG IIC_VAR
0000: R 12 BASE: DS 1 ;Pointer to I2C table (till
;256)
0001: 13 NR_BYTES: DS 1 ;Number of bytes to rcv/trm
0002: 14 IIC_CNT:DS 1 ;I2C byte counter
0003: 15 SLAVE: DS 1 ;Slave address after START
16 ;
17 ;Define variable segment
18 BIT_VAR SEGMENT DATA BITADDRESSABLE
----
19 RSEG BIT_VAR
0000: R 20 STATUS: DS 1 ;Byte with flags
0000 R 21 I2C_END BIT STATUS.0 ;Defines if a I2C
;transmission is finished
; '1' is finished
; '0' is not ready
0000 R 24 DIR BIT STATUS.3 ;Defines direction of I2C
;transmission
; '1':Transmit '0':Receive
25 ;
26 ;
27 ;Define code segment for routine
28 IIC_INT SEGMENT CODE PAGE
----
29 RSEG IIC_INT
30 ;
31 ;Program uses registers in RB1
32 USING 1
33 ;
0000: R 34 INT0_SRV:
0000: C0E0 35 PUSH ACC ;Save acc. on psw on stack
0002: C0D0 36 PUSH PSW
0004: 75D008 37 MOV PSW,#08H ;Select register bank 1
0007: 300016 R 38 JNB DIR,RECEIVE ;Test direction bit
;8584 is MST/TRM
40 ;
41 ;Program part to transmit bytes to IIC bus
000A: E502 R 42 MOV A,IIC_CNT ;Compare IIC_CNT and
;NR_BYTES
000C: B50105 R 43 CJNE A,NR_BYTES,PROCEED
000F: 120000 R 44 CALL STOP ;All bytes transmitted
0012: 8032 45 JMP EXIT
0014: A800 R 46 PROCEED:MOV R0,BASE ;RAM pointer
0016: E6 47 MOV A,@R0 ;Source is internal RAM
0017: 0500 R 48 INC BASE ;Update pointer of table
0019: 120000 R 49 CALL SENDBYTE ;Send byte to IIC bus
001C: 0502 R 50 INC IIC_CNT ;Update byte counter
001E: 8026 51 JMP EXIT

```

# Interfacing the PCF8584 I<sup>2</sup>C-bus controller to 80C51 family microcontrollers

AN425

```

52 ;
53 ;
54 ;Program to receive byte from IIC bus
0020: RECEIVE:
0020: E502 R 56 MOV A,IIC_CNT ;Test if last byte is to be
;received
0022: 04 57 INC A
0023: 04 58 INC A
0024: B50105 R 59 CJNE A,NR_BYTES,PROC_RD
0027: 7448 60 MOV A,#01001000B;Last byte to be received.
;Disable ACK
0029: 120000 R 61 CALL SENDCONTR ;Write control word to
;PCF8584
002C: 120000 R 62 PROC_RD:CALL READBYTE ;Read I2C byte
002F: FC 63 MOV R4,A ;Save accu
64 ;If RECEIVE is entered after the transmission of
65 ;START+address then the result of READBYTE is not
66 ;relevant. READBYTE is used to start the generation
;of the clock pulses for the next byte to read.
67 ;This situation occurs when IIC_CNT is 0
0030: E4 68 CLR A ;Test IIC_CNT
0031: B50202 R 69 CJNE A,IIC_CNT,SAVE
0034: 8006 70 JMP END_TEST ;START is send. No relevant
;data in data reg. of 8584
0036: A800 R 71 SAVE: MOV R0,BASE
0038: EC 72 MOV A,R4 ;Destination is internal RAM
0039: F6 73 MOV GR0,A
003A: 0500 R 74 INC BASE
003C: 0502 R 75 END_TEST:INC IIC_CNT ;Test if all bytes are
;received
003E: E501 R 76 MOV A,NR_BYTES
0040: B50203 R 77 CJNE A,IIC_CNT,EXIT
0043: 120000 R 78 CALL STOP ;All bytes received
79 ;
0046: D0D0 80 EXIT: POP PSW ;Restore PSW and accu
0048: D0E0 81 POP ACC
004A: 32 82 RETI
83 ;
004B: 84 END

```

# Interfacing the PCF8584 I<sup>2</sup>C-bus controller to 80C51 family microcontrollers

AN425

ASM51 TSW ASSEMBLER Send a string of bytes to the PCF8577 on OM1016

```

LOC   OBJ           LINE  SOURCE
      1  $TITLE (Send a string of bytes to the PCF8577 on
      2  OM1016)
      3  ;
      4  ;This program is an example to transmit bytes via
      5  ;PCF8584
      6  ;to the I2C-bus
      7  ;
      8  PUBLIC  SLAVE_ADR,I2C_CLOCK,PCF8584
      9  EXTRN  CODE(I2C_INIT,INT0_SRV,START)
     10  EXTRN  BIT(I2C_END,DIR)
     11  EXTRN  DATA(BASE,NR_BYTES,IIC_CNT,SLAVE)
     12  ;
     13  ;Define used segments
     14  USER   SEGMENT CODE      ;Segment for user program
     15  RAMTAB SEGMENT DATA    ;Segment for table in
     16  RAMVAR SEGMENT DATA    ;Segment for RAM variables
     17  ;in RAM
     18  ;
----
     19  RSEG   RAMVAR
0000:  R     20  STACK: DS 20      ;Reserve stack area
     21  ;
     22  ;
----
     23  CSEG AT 00H
0000: 020000 R     24  JMP MAIN      ;Reset vector
     25  ;
     26  ;
----
     27  CSEG AT 03H
0003: 020000 R     28  JMP INT0_SRV  ;I2C interrupt vector
     29  ;(INT0/)
     30  ;
----
     31  RSEG USER
     32  ;Define I2C clock, own slave address and PCF8584
     33  ;hardware address
0055  33  SLAVE_ADR EQU 55H      ;Own slave address is 55H
001C  34  I2C_CLOCK EQU 00011100B ;12.00MHz/90kHz
0000  35  PCF8584 EQU 0000H      ;PCF8584 address with A0=0
     36  ;0000: 7581FF R 37  MAIN:  MOV SP,#STACK-1 ;Initialise stack pointer
     38  ;Initialise 8031 interrupt registers for I2C
     39  ;interrupt
0003: D2A8 39  SETB EX0      ;Enable interrupt INT0/
0005: D2AF 40  SETB EA      ;Set global enable
0007: D2B8 41  SETB PX0      ;Priority level '1'
0009: D288 42  SETB IT0      ;INT0/ on falling edge
     43  ;
     44  ;Initialise PCF8584
000B: 120000 R     45  CALL I2C_INIT
     46  ;
     47  ;Make a table in RAM with data to be transmitted.
000E: 120021 R     48  CALL MAKE_TAB
     49  ;
     50  ;Set variables to control PCF8584

```

# Interfacing the PCF8584 I<sup>2</sup>C-bus controller to 80C51 family microcontrollers

AN425

```

0011: D200    R   51      SETB DIR          ;DIR='transmission'
0013: 750000  R   52      MOV BASE,#TABLE  ;Start address of I2C-data
0016: 750005  R   53      MOV NR_BYTES,#05H ;5 bytes must be
                                ;transferred
0019: 750074  R   54      MOV SLAVE,#01110100B ;Slave address PCF8577
                                ; + WR/
001C: 120000  R   55      CALL START      ;Start I2C transmission
56 ;
57 ;
001F: 80FE    R   58      LOOP:  JMP LOOP   ;Endless loop when program
                                ;is finished
59 ;
60 ;
0021:        R   61      MAKE_TAB:
0021: 7800    R   62      MOV R0,#TABLE   ;Make data ready for I2C
                                ;transmission
0023: 7600    R   63      MOV @R0,#00    ;Controlword PCF8577
0025: 08     R   64      INC R0
0026: 76FC    R   65      MOV @R0,#0FCH  ;'0'
0028: 08     R   66      INC R0
0029: 7660    R   67      MOV @R0,#60H   ;'1'
002B: 08     R   68      INC R0
002C: 76DA    R   69      MOV @R0,#0DAH  ;'2'
002E: 08     R   70      INC R0
002F: 76F2    R   71      MOV @R0,#0F2H  ;'3'
0031: 22     R   72      RET
73 ;
74 ;
----
0000:        R   75      RSEG RAMTAB
0000:        R   76      TABLE: DS 10      ;Reserve space in internal
                                ;data RAM
77 ;
78 ;
79 ;
000A:        R   80      END

```

# Interfacing the PCF8584 I<sup>2</sup>C-bus controller to 80C51 family microcontrollers

AN425

```

ASM51 TSW ASSEMBLER Receive 2 bytes from the PCF8574P on OM1016

LOC OBJ LINE SOURCE
1 $TITLE (Receive 2 bytes from the PCF8574P on OM1016)
2 $PAGELENGTH(40)
3 ;
4 ;This program is an example to receive bytes via
;PCF8584
5 ;from the I2C-bus
6 ;
7 PUBLIC SLAVE_ADR,I2C_CLOCK,PCF8584
8 EXTRN CODE(I2C_INIT,INT0_SRV,START)
9 EXTRN BIT(I2C_END,DIR)
10 EXTRN DATA(BASE,NR_BYTES,IIC_CNT,SLAVE)
11 ;
12 ;
13 ;Define used segments
14 USER SEGMENT CODE ;Segment for user program
15 RAMTAB SEGMENT DATA ;Segment for table in
;internal RAM
16 RAMVAR SEGMENT DATA ;Segment for RAM variables
;in RAM
17 ;
18 ;
----
19 RSEG RAMVAR
0000: R 20 STACK: DS 20 ;Reserve stack area
21 ;
22 ;
----
23 CSEG AT 00H
0000: 020000 R 24 JMP MAIN ;Reset vector
25 ;
26 ;
----
27 CSEG AT 03H
0003: 020000 R 28 JMP INT0_SRV ;I2C interrupt vector
;(INT0/)
29 ;
30 ;
----
31 RSEG USER
32 ;Define I2C clock, own slave address and PCF8584
;hardware address
0055 33 SLAVE_ADR EQU 55H ;Own slave address is 55H
001C 34 I2C_CLOCK EQU 00011100B ;12.00MHz/90kHz
0000 35 PCF8584 EQU 0000H ;PCF8584 address with A0=0
36 ;0000: 7581FF R 37 MAIN: MOV SP,#STACK-1 ;Initialise stack pointer
38 ;Initialise 8031 interrupt registers for I2C
;interrupt
0003: D2A8 39 SETB EX0 ;Enable interrupt INT0/
0005: D2AF 40 SETB EA ;Set global enable
0007: D2B8 41 SETB PX0 ;Priority level '1'
0009: D288 42 SETB IT0 ;INT0/ on falling edge
43 ;
44 ;Initialise PCF8584
000B: 120000 R 45 CALL I2C_INIT
46 ;
47 ;Set variables to control PCF8584
000E: C200 R 48 CLR DIR ;DIR='receive'
0010: 750000 R 49 MOV BASE,#TABLE ;Start address of I2C-data
0013: 750002 R 50 MOV NR_BYTES,#02H ;2 bytes must be received
0016: 75004F R 51 MOV SLAVE,#01001111B ;Slave address PCF8574
; + RD

```

---

# Interfacing the PCF8584 I<sup>2</sup>C-bus controller to 80C51 family microcontrollers

---

AN425

```
0019: 120000 R 52 CALL START ;Start I2C transmission
53 ;
54 ;
001C: 80FE 55 LOOP: JMP LOOP ;Endless loop when program
;is finished
56 ;
57 ;
---- 58 RSEG RAMTAB
0000: R 59 TABLE: DS 10 ;Reserve space in internal
;data RAM
60 ;for received I2C data
61 ;
62 ;
000A: 63 END
```

# Interfacing the PCF8584 I<sup>2</sup>C-bus controller to 80C51 family microcontrollers

AN425

ASM51 TSW ASSEMBLER Demo program for PCF8584 I2C-routines

```

LOC   OBJ           LINE  SOURCE
-----
1     $TITLE (Demo program for PCF8584 I2C-routines)
2     $PAGELENGTH(40)
3     ;Program displays on the LCD display the time (with
4     ;PCF8583). Dots on LCD display blink every second.
5     ;On the LED display the values of the successive
6     ;analog input channels are shown.
7     ;Program reads analog channels of PCF8591P.
8     ;Channel number and channel value are displayed
9     ;successively.
10    ;Values are displayed on LCD and LED display on I2C
11    ;demo board.
12    ;
13    PUBLIC  SLAVE_ADR,I2C_CLOCK,PCF8584
14    EXTRN  CODE(I2C_INIT,INT0_SRV,START)
15    EXTRN  BIT(I2C_END,DIR)
16    EXTRN  DATA(BASE,NR_BYTES,IIC_CNT,SLAVE)
17    ;
18    ;Define used segments
19    USER  SEGMENT  CODE    ;Segment for user program
20    RAMTAB SEGMENT  DATA    ;Segment for table in
21    ;internal RAM
22    RAMVAR SEGMENT  DATA    ;Segment for variables
23    ;
24    RSEG  RAMVAR
25    ----
26    0000:      R 23 STACK: DS 20          ;Stack area (20 bytes)
27    0014:      24 PREVIOUS: DS 1        ;Store for previous seconds
28    0015:      25 CHANNEL:DS 1          ;Channel number to be
29    ;                                     ;sampled
30    0016:      26 AN_VAL: DS 1          ;Analog value sampled
31    ;                                     ;channel
32    0017:      27 CONVAL: DS 3          ;Converted BCD value sampled
33    ;                                     ;channel
34    28 ;
35    29 CSEG AT 00H
36    0000: 020000 R 30 LJMP MAIN          ;Reset vector
37    31 ;
38    32 CSEG AT 03H ;INT0/
39    0003: 020000 R 33 LJMP INT0_SRV      ;Vector I2C-interrupt
40    34 ;
41    35 ;
42    ----
43    36 RSEG USER37 ;Define I2C clock, own slave address and address for
44    ;main processor
45    0055 SLAVE_ADR EQU 55H ;Own slaveaddress is 55h
46    001C I2C_CLOCK EQU 00011100B ;12.00MHz/90kHz
47    0000 PCF8584 EQU 0000H ;Address of PCF8584. This
48    ;must be an EVEN number!!
49    41 ;Define addresses of I2C peripherals
50    00A3 PCF8583R EQU 10100011B ;Address PCF8583 with Read
51    ;active
52    00A2 PCF8583W EQU 10100010B ;Address PCF8583 with Write
53    ;active
54    009F PCF8591R EQU 10011111B ;Address PCF8591 with Read
55    ;active
56    009E PCF8591W EQU 10011110B ;Address PCF8591 with Write
57    ;active

```



# Interfacing the PCF8584 I<sup>2</sup>C-bus controller to 80C51 family microcontrollers

AN425

ASM51 TSW ASSEMBLER Demo program for PCF8584 I2C-routines

```

LOC  OBJ          LINE  SOURCE
0074          46  PCF8577W EQU 01110100B ;Address PCF8577 with Write
                                ;active
0076          47  SAA1064W EQU 01110110B ;Address SAA1064 with Write
                                ;active
                                48  ;
0000: 7581FF    R  49  MAIN:  MOV SP,#STACK-1 ;Define stack pointer
                                50  ;Initialise 80C31 interruptregisters for I2C
                                ;interrupt (INT0/)
0003: D2A8     51          SETB EX0          ;Enable interrupt INT0/
0005: D2AF     52          SETB EA          ;Set global enable
0007: D2B8     53          SETB PX0          ;Priority level is '1'
0009: D288     54          SETB IT0          ;INT0/ on falling edge
                                55  ;Initialise PCF8584
000B: 120000   R  56          CALL I2C_INIT
                                57  ;
000E: 751500   R  58          MOV CHANNEL,#00 ;Set AD-channel
                                59  ;
                                60  ;Time must be read from PCD8583.
                                61  ;First write word address and control register of
                                ;PCD8583.
0011: D200     R  62          SETB DIR          ;DIR='transmission'
0013: 750000   R  63          MOV BASE,#TABLE ;Start address I2C data
0016: 750002   R  64          MOV NR_BYTES,#02H ;Send 2 bytes
0019: 7500A2   R  65          MOV SLAVE,#PCF8583W
001C: E4       66          CLR A
001D: F500     R  67          MOV TABLE,A      ;Data to be sent (word
                                ;address).
001F: F501     R  68          MOV TABLE+1,A    ; " " (control
                                ;byte)
0021: 120000   R  69          CALL START        ;Start transmission.
0024: 3000FD   R  70  FIN_1: JNB I2C_END,FIN_1 ;Wait till transmission
                                ;finished
                                71  ;Send word address before reading time
0027: D200     R  72  REPEAT: SETB DIR    ;'transmission'
0029: 750000   R  73          MOV BASE,#TABLE ;I2C data
002C: 7500A2   R  74          MOV SLAVE,#PCF8583W
002F: 7401     75          MOV A,#01
0031: F500     R  76          MOV NR_BYTES,A    ;Send 1 byte
0033: F500     R  77          MOV TABLE,A      ;Data to be sent is '1'
0035: 120000   R  78          CALL START        ;Start I2C transmission
0038: 3000FD   R  79  FIN_2: JNB I2C_END,FIN_2 ;Wait till transmission
                                ;finished
                                80  ;
                                81  ;Time can now be read from PCD8583. Data read is
                                82  ;hundredths of sec's, sec's, min's and hr's
003B: C200     R  83          CLR DIR          ;DIR='receive'
003D: 750000   R  84          MOV BASE,#TABLE ;I2C table
0040: 750004   R  85          MOV NR_BYTES,#04; 4 bytes to receive
0043: 7500A3   R  86          MOV SLAVE,#PCF8583R
0046: 120000   R  87          CALL START        ;Start I2C reception
0049: 3000FD   R  88  FIN_3: JNB I2C_END,FIN_3 ;Wait till finished
                                89  ;
                                90  ;Transfer data to R2...R5
004C: 7800     R  91          MOV R0,#TABLE    ;Set pointers
004E: 7902     92          MOV R1,#02H      ;Pointer R2
0050: E6       93  TRANSFER:MOV A,GR0

```

# Interfacing the PCF8584 I<sup>2</sup>C-bus controller to 80C51 family microcontrollers

AN425

ASM51 TSW ASSEMBLER Demo program for PCF8584 I2C-routines

```

LOC  OBJ          LINE  SOURCE
0051: F7          94      MOV @R1,A
0052: 08          95      INC R0
0053: 09          96      INC R1
0054: D500F9     R   97      DJNZ NR_BYTES,TRANSFER
0057: ED          98      MOV A,R5          ;Mask of hour counter
0058: 543F       99      ANL A,#3FH
005A: FD         100     MOV R5,A
101 ;
102 ;Data must now be displayed on LCD display.
103 ;First minutes and hours (in R4 and R5) must be
104 ;converted from BCD to LCD segment data.The segment
;data
105 ;will be transferred to TABLE. R0 is pointer to
;table
005B: 7800     R   106     MOV R0,#TABLE
005D: 7600     107     MOV @R0,#00H      ;Control word for PCF8577
005F: 08       108     INC R0 0060: 120080 R 109      CALL CONV
110 ;
111 ;Switch on dp between hours and minutes
0063: 430301   R   112     ORL TABLE+3,#01H
113 ;If lsb of seconds is '0' then switch on dp.
0066: EB       114     MOV A,R3          ;Get seconds
0067: 13       115     RRC A            ;lsb in carry
0068: 4003     116     JC PROCEED
006A: 430101   R   117     ORL TABLE+1,#01H;switch on dp
118 ;
119 ;Now the time (hours,minutes) can be displayed on
;the LCD
006D:          120     PROCEED:
006D: D200     R   121     SETB DIR          ;Direction 'transmit'
006F: 750000   R   122     MOV BASE,#TABLE
0072: 750005   R   123     MOV NR_BYTES,#05H
0075: 750074   R   124     MOV SLAVE,#PCF8577W
0078: 120000   R   125     CALL START        ;Start transmission
126 ;
007B: 3000FD   R   127     FIN_4: JNB I2C_END,FIN_4
007E: 8026     128     JMP ADCON         ;Proceed with AD-conversion
;part
129 ;
130 ;*****
131 ;Routines used by clock part of demo
132 ;
133 ;CONV converts hour and minute data to LCD data and
;stores
134 ;it in TABLE.
0080: 90009C   R   135     CONV:  MOV DPTR,#LCD_TAB ;Base for LCD segment
;table
0083: ED       136     MOV A,R5          ;Hours to accu
0084: C4       137     SWAP A           ;Swap nibbles
0085: 120096   R   138     CALL LCD_DATA    ;Convert 10's hours to LCD
;data in table
0088: ED       139     MOV A,R5          ;Get hours
0089: 120096   R   140     CALL LCD_DATA
008C: EC       141     MOV A,R4          ;Get minutes
008D: C4       142     SWAP A
008E: 120096   R   143     CALL LCD_DATA    ;Convert 10's minutes

```

# Interfacing the PCF8584 I<sup>2</sup>C-bus controller to 80C51 family microcontrollers

AN425

ASM51 TSW ASSEMBLER Demo program for PCF8584 I2C-routines

```

LOC  OBJ          LINE  SOURCE
0091: EC          144      MOV A,R4
0092: 120096     R 145      CALL LCD_DATA ;Convert minutes
0095: 22          146      RET
                                147 ;
                                148 ;LCD_DATA gets data from segment table and stores it
                                ;in TABLE
0096: 540F          149 LCD_DATA:ANL A,#0FH ;Mask off LS-nibble
0098: 93          150      MOVC A,@A+DPTR ;Get LCD segment data
0099: F6          151      MOV @R0,A ;Save data in table
009A: 08          152      INC R0
009B: 22          153      RET
                                154 ;
                                155 ;LCD_TAB is conversion table for LCD
009C:             156 LCD_TAB:
009C: FC60DA      157      DB 0FCH,60H,0DAH; '0','1','2'
009F: F266B6      158      DB 0F2H,66H,0B6H; '3','4','5'
00A2: 3EE0FE      159      DB 3EH,0E0H,0FEH; '6','7','8'
00A5: E6          160      DB 0E6H ; '9'
                                161 ;
                                162 ;*****
                                163 ;
                                164 ;
                                165 ;These part of the program reads an analog
                                ;input-channel.
                                166 ;Displaying is done on the LED-display
                                167 ;On odd-seconds the channel number will be
                                ;displayed.
                                168 ;On even-seconds the analog value of this channel is
                                ;displayed
                                169 ;Then the next channel is displayed.
                                170 ;
00A6: EB          171 ADCON: MOV A,R3 ;Get seconds
00A7: 13          172      RRC A ;lsb to carry
00A8: 503C          173      JNC NEW_MEAS ;Even seconds; do a
                                ;measurement on the current
                                ;channel
                                174 ;
                                175 ;Display and/or update channel
00AA: 33          176      RLC A ;Restore accu
00AB: B51402     R 177      CJNE A,PREVIOUS,NEW_CH ;If new seconds,
                                ;update channel number
00AE: 800A          178      JMP DISP_CH
00B0: 0515     R 179      NEW_CH: INC CHANNEL
00B2: E515     R 180      MOV A,CHANNEL ;If channel=4 then
                                ;channel=-0
00B4: B40403      181      CJNE A,#04,DISP_CH
00B7: 751500     R 182      MOV CHANNEL,#00
00BA: 8B14     R 183      DISP_CH:MOV PREVIOUS,R3 ;Update previous seconds
00BC: E515     R 184      MOV A,CHANNEL ;Get segment value of
                                ;channel
00BE: 900193     R 185      MOV DPTR,#LED_TAB
00C1: 93          186      MOVC A,@A+DPTR
                                187 ;
00C2: 7800     R 188      MOV R0,#TABLE ;Fill table with I2C data

```

# Interfacing the PCF8584 I<sup>2</sup>C-bus controller to 80C51 family microcontrollers

AN425

ASM51 TSW ASSEMBLER Demo program for PCF8584 I2C-routines

```

LOC  OBJ          LINE  SOURCE
00C4: 7600        189      MOV @R0,#00      ;SAA1064 instruction byte
00C6: 08          190      INC R0
00C7: 7677        191      MOV @R0,#77H    ;SAA1064 control byte
00C9: 08          192      INC R0
00CA: F6          193      MOV @R0,A       ;Channel number
00CB: E4          194      CLR A
00CC: 08          195      INC R0
00CD: F6          196      MOV @R0,A       ;Second digit
00CE: 08          197      INC R0
00CF: F6          198      MOV @R0,A       ;Third digit
00D0: 08          199      INC R0
00D1: F6          200      MOV @R0,A       ;Fourth byte
                201      ;
00D2: D200        R 202      SETB DIR        ;I2C transmission of channel
                ;number
00D4: 750000      R 203      MOV BASE,#TABLE
00D7: 750006      R 204      MOV NR_BYTES,#06H
00DA: 750076      R 205      MOV SLAVE,#SAA1064W
00DD: 120000      R 206      CALL START
                207      ;
00E0: 3000FD      R 208      FIN_5: JNB I2C_END,FIN_5
00E3: 020027      R 209      JMP REPEAT      ; Repeat clock and AD cycle
                ; again
                210      ;
                211      ;
                212      ;Measure and display the value of an AD-channel
00E6: 120108      R 213      NEW_MEAS: CALL AD_VAL ;Do measurement
                214      ;Wait till values are available
00E9: 3000FD      R 215      FIN_6: JNB I2C_END,FIN_6
                216      ;Relevant byte in TABLE+1. Transfer to AN_VAL
00EC: 7801        R 217      MOV R0,#TABLE+1
00EE: 8616        R 218      MOV AN_VAL,@R0
00F0: E516        R 219      MOV A,AN_VAL    ;Channel value in accu for
                ;conversion
                220      ;AN_VAL is converted to BCD value of the measured
                ;voltage.
                221      ;Input value for CONVERT in accu
                222      ;Address for MSByte in R1
00F2: 7917        R 223      MOV R1,#CONVAL
00F4: 120154      R 224      CALL CONVERT
                225      ;Convert 3 bytes of CONVAL to LED-segments
00F7: 900193      R 226      MOV DPTR,#LED_TAB ;Base of segment table
00FA: 7817        R 227      MOV R0,#CONVAL
00FC: 12018A      R 228      CALL SEG_LOOP
                229      ;Display value of channel to LED display
00FF: 12012C      R 230      CALL LED_DISP
0102: 3000FD      R 231      FIN_8: JNB I2C_END,FIN_8 ;Wait till I2C
                ;transmission is ended
0105: 020027      R 232      JMP REPEAT      ;Repeat clock and AD cycle
                233      ;
                234      ;*****
                235      ;Routines used for AD converter.
                236      ;
                237      ;AIN reads an analog values from channel denoted by
                ;CHANNEL.

```

# Interfacing the PCF8584 I<sup>2</sup>C-bus controller to 80C51 family microcontrollers

AN425

ASM51 TSW ASSEMBLER Demo program for PCF8584 I2C-routines

```

LOC  OBJ          LINE  SOURCE
                                238 ;Send controlbyte:
0108: D200      R   239 AD_VAL: SETB DIR          ;I2C transmission
010A: 7800      R   240          MOV R0,#TABLE        ;Define control word
010C: A615      R   241          MOV @R0,CHANNEL
010E: 750000    R   242          MOV BASE,#TABLE        ;Set base at table
0111: 750001    R   243          MOV NR_BYTES,#01H     ;Number of bytes to be
                                ;send
0114: 75009E    R   244          MOV SLAVE,#PCF8591W   ;Slave address PCF8591
0117: 120000    R   245          CALL START            ;Start transmission of
                                ;controlword
011A: 3000FD    R   246 FIN_7:  JNB I2C_END,FIN_7 ;Wait until transmission is
                                ;finished
                                247 ;Read 2 data bytes from AD-converter
                                248 ;First data byte is from previous conversion and not
                                249 ;relevant
011D: C200      R   250          CLR DIR              ;I2C reception
011F: 750000    R   251          MOV BASE,#TABLE     ;Bytes must be stored in
                                ;TABLE
0122: 750002    R   252          MOV NR_BYTES,#02H   ;Receive 3 bytes
0125: 75009F    R   253          MOV SLAVE,#PCF8591R ;Slave address PCF8591
0128: 120000    R   254          CALL START
012B: 22                255          RET
                                256 ;
                                257 ;LED_DISP displays the data of 3 bytes from address
                                ;CONVAL
012C:                258 LED_DISP:
012C: 431780    R   259          ORL CONVAL,#80H    ;Set decimal point
012F: 7800      R   260          MOV R0,#TABLE
0131: 7917      R   261          MOV R1,#CONVAL
0133: 7600      262          MOV @R0,#00        ;SAA1064 instruction byte
0135: 08                263          INC R0
0136: 7677      264          MOV @R0,#01110111B ;SAA1064 control byte
0138: 08                265          INC R0
0139: 7600      266          MOV @R0,#00        ;First LED digit
013B: 08                267          INC R0
013C: 120185    R   268          CALL GETBY         ;Second digit
013F: 120185    R   269          CALL GETBY         ;Third digit
0142: 120185    R   270          CALL GETBY         ;Fourth digit
0145: D200      R   271          SETB DIR           ;I2C transmission
0147: 750000    R   272          MOV BASE,#TABLE
014A: 750006    R   273          MOV NR_BYTES,#06
014D: 750076    R   274          MOV SLAVE,#01110110B
0150: 120000    R   275          CALL START         ;Start I2C transmission
0153: 22                276          RET
                                277 ;
                                278 ;CONVERT calculates the voltage of the analog value.
                                279 ;Analog value must be in accu
                                280 ;BCD result (3 bytes) is stored from address stored
                                ;in R1
                                281 ;Calculation: AN_VAL*(5/256)
0154: 75F005    R   282 CONVERT:MOV B,#05
0157: A4                283          MUL AB
                                284 ;b2..b0 of reg. B : 2E+2..2E0
                                285 ;b7..b0 of accu  : 2E-1..2E-8
0158: A7F0      286          MOV @R1,B          ;Store MSB (10E0-units)
015A: 09                287          INC R1

```

# Interfacing the PCF8584 I<sup>2</sup>C-bus controller to 80C51 family microcontrollers

AN425

ASM51 TSW ASSEMBLER Demo program for PCF8584 I2C-routines

```

LOC  OBJ          LINE  SOURCE

015B: 7700          288      MOV @R1,#00      ;Calculate 10E-1 unit
                                ;(10E-1 is 19h)
015D: B41C02       289  TEN_CH: CJNE A,#19H+03H,V1 ;Check if accu <= 0.11
0160: 8002          290      JMP TENS         ;accu=0.11; update tens
0162: 4006          291  V1:   JC  NK_CON   ;accu<0.11; update hundreds
0164: C3           292  TENS: CLR C      ;Calculate new value
0165: 9419          293      SUBB A,#19H
0167: 07           294      INC @R1         ;Update BCD byte
0168: 80F3          295      JMP TEN_CH
                                296 ;Correction may be necessary. With 8 bits '0.1' is
                                ;in fact 0.0976.
                                297 ;A digit of '0A' may appear. Correct this by
                                ;decrementing the digit.
                                298 ;The intermediate result result must be corrected
                                ;with 10*(0.1-0.0976)
                                299 ;This is 06H
016A: B70A03       300  NK_CON: CJNE @R1,#0AH,PROC_CON ; If digit is '0A'
                                ;then correct
016D: 17           301      DEC @R1
016E: 2419          302      ADD A,#19H
0170: 09           303  PROC_CON:INC R1
0171: 7700          304      MOV @R1,#00      ;Calculate 10E-2 units
0173: B40302       305  HUND: CJNE A,#03H,V2 ;Check if accu <= 10E-2
0176: 8002          306      JMP HUNS        ;accu=10E-2; update hundreds
0178: 4006          307  V2:   JC  FINISH  ;accu<10E-2; conversion
                                ;finished
017A: C3           308  HUNS: CLR C      ;Calculate new value
017B: 9403          309      SUBB A,#03H
017D: 07           310      INC @R1         ;Update BCD byte
017E: 80F3          311      JMP HUND
0180: B70A01       312  FINISH: CJNE @R1,#0AH,FIN ;Check if result is '0A'.
                                ;Then correct.
0183: 17           313      DEC @R1
0184: 22           314  FIN:   RET
                                315 ;
                                316 ;CALLBY transfers byte from @R1 to @R0
0185: E7           317  GETBY: MOV A,@R1
0186: F6           318      MOV @R0,A
0187: 08           319      INC R0
0188: 09           320      INC R1
0189: 22           321      RET
                                322 ;
                                323 ;SEG_LOOP converts 3 values to segment values.
                                324 ;R0 contains address of source and destination
                                325 ;DPTR contains base of table
018A: 7903          326  SEG_LOOP: MOV R1,#03 ;Loop counter
018C: E6           327  INLOOP: MOV A,@R0 ;Get value to be displayed
018D: 93           328      MOVC A,@A+DPTR ;Get segment value from
                                ;table
018E: F6           329      MOV @R0,A      ;Store segment data
018F: 08           330      INC R0
0190: D9FA          331      DJNZ R1,INLOOP
0192: 22           332      RET
                                333 ;
                                334 ;

```

# Interfacing the PCF8584 I<sup>2</sup>C-bus controller to 80C51 family microcontrollers

AN425

ASM51 TSW ASSEMBLER Demo program for PCF8584 I2C-routines

```
LOC  OBJ          LINE  SOURCE
                                335 ;LED_TAB is conversion table for BCD to LED segments
                                336 LED_TAB:
0193:  7D483E        337      DB 7DH,48H,3EH ; '0','1','2'
0196:  6E4B67        338      DB 6EH,4EH,67H ; '3','4','5'
0199:  734C7F        339      DB 73H,4CH,7FH ; '6','7','8'
019C:  4F             340      DB 4FH ; '9'
                                341 ;
                                342 ;*****
                                343 ;
----  344      RSEG RAMTAB
0000:  R 345 TABLE: DS 10
                                346 ;
000A:  347      END
```

# What is Teletext?

Author: Marc Schneider

## WHAT IS TELETEXT?

Teletext is a system that was developed in the late '70s to deliver public information to television viewers in the comfort of their home. Since it's creation, Teletext has undergone several enhancements to improve it's flexibility, and yet maintain a low overall cost to the customer. In the 80's, new extensions were added to Teletext handle independent data services, and the format continues to expand to this day.

Multimedia computing is now discovering the benefits of having Teletext reception as another value added feature. With the ever increasing quest for more information on the desktop, applications can range from stock trading, electronic news, E-Mail, downloadable software, education, and customer service just to name a few.

Even though Teletext format has been enhanced quite a lot since it's original inception, the basic functionality is still very much the same. Here are a few examples of this:

### Basic Teletext system overview

- Teletext is a format to transmit data within a video signal
- Can be multiplexed with the video, or not
- Data rate is a few MBit/s
- Accepted global standard (WST)
- Secure delivery data channel
- Data error checking
- Low cost
- Uni-directional
- Page format: 24 rows x 40 columns

## HOW IS IT ENCODED IN A VIDEO SIGNAL?

There are two common methods for encoding the Teletext data into a video stream. The most common is to use the Vertical Blanking Interval or VBI. This is a generally unused space located between the vertical sync pulse and the actual active video picture. Because of the limited number of available lines in the VBI, the actual amount of data that can be transmitted is limited to about 17.76Kbits/sec times the number of transmitted lines. So, if we were to transmit 3 lines of Teletext data per field, that would work out to:

One horizontal line (525) of data = 37 Bytes  
or = 296 bits per line/field

$$\begin{array}{r}
 296 \\
 \times 60 \text{ (fields per second)} \\
 \hline
 17,760 \text{ bits/sec per line data rate} \\
 \times 3 \text{ lines/sec} \\
 \hline
 53,280 \text{ bits/sec}
 \end{array}$$

So, a three line/field transmission has an effective data rate close to ISDN rates!

If, however, the broadcaster has a dedicated channel (cable, MDS, satellite, video LAN, etc.), it is then possible to put Teletext data on every line. In this case, the data through-output would increase to almost half of Ethernet rates!

One horizontal line (525) of data = 37 Bytes  
or = 296 bits per line/field

$$\begin{array}{r}
 296 \\
 \times 60 \text{ (fields per second)} \\
 \hline
 17,760 \text{ bits/sec per line data rate} \\
 \times 251 \text{ (usable lines/field)} \\
 \hline
 4,457,760 \text{ bits/sec data rate}
 \end{array}$$

Now the data rate has been increased to over 4.5Mbits/sec, half Ethernet speed!



# What is Teletext?

## WHERE CAN TELETEXT DATA RESIDE IN A VIDEO SIGNAL?

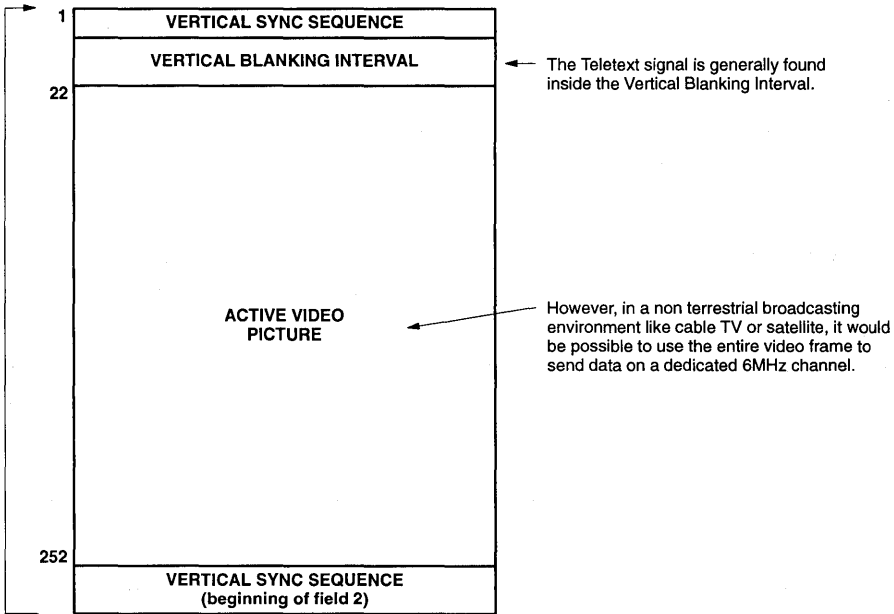

## WHAT DOES THE DATA LOOK LIKE?

Each Video line use to convey the Teletext data is called a Teletext Data Line.

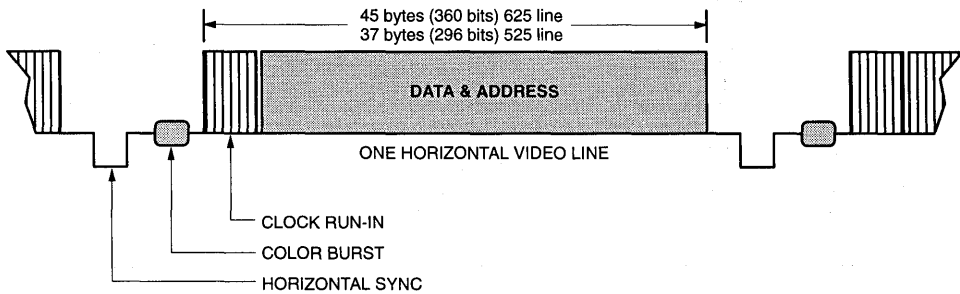



# What is Teletext?

## HOW IS IT BROADCAST TO CUSTOMERS?

The most common way for Teletext to reach a large customer base is to send it using normal over-the-air broadcast television transmissions. Although this is the common approach, it is not the only method. Cable companies can distribute the data on a dedicated channel or add it to the VBI of an existing channel. Multi-point Distribution System operators (MMDS or wireless cable) can provide Teletext data via direct microwave transmissions to the customer. Satellite broadcasters can use the same approach as well. Figure 3 is an example.

And signal distribution isn't required to general off-air distribution. Teletext can also be used over a video local area network (VLAN) for supporting anything from printing devices, data servers, and even individual workstations. A simple way to provide secure data delivery in a growing multi-media environment and at a low cost.

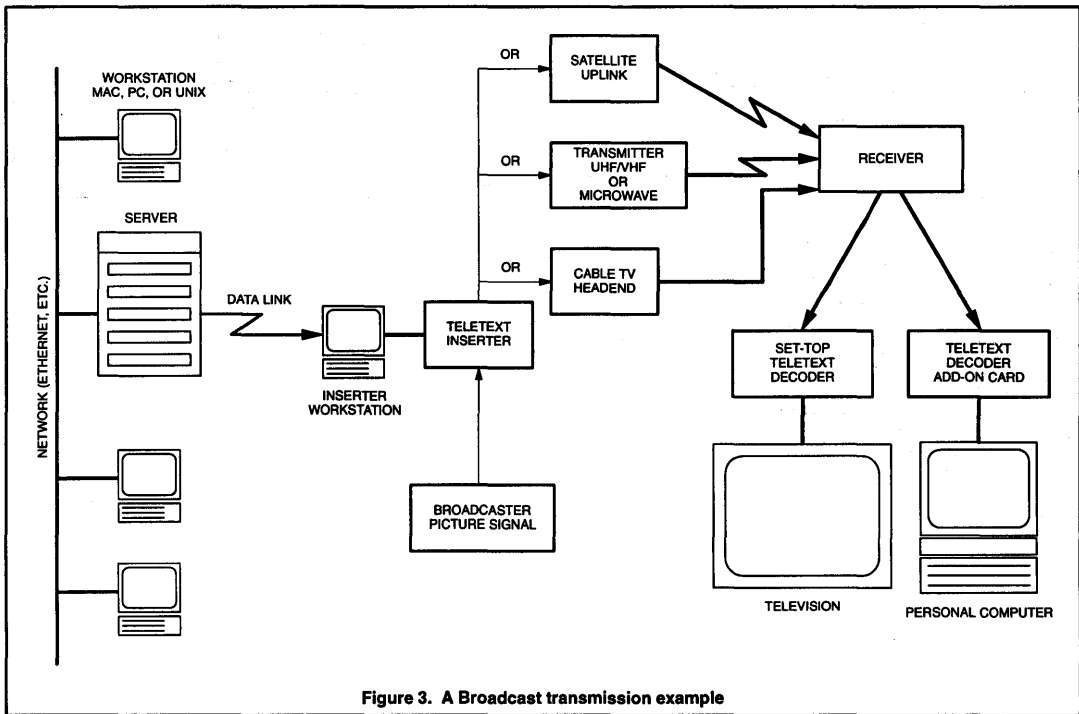

Figure 3. A Broadcast transmission example

# What is Teletext?

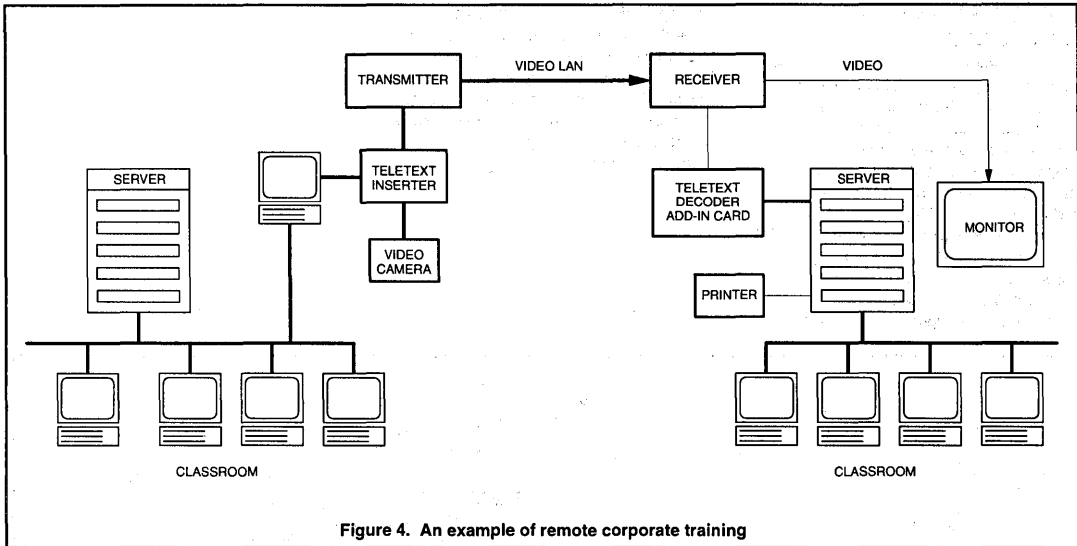

Figure 4. An example of remote corporate training

In Figure 4, an instructor at a corporate headquarters could be teaching a class locally while also delivering the same information to students at multiple remote sites. In addition to the normal video and audio transmissions, the instructor could send data specifically to individual students at the remote site (or sites) on demand over the same video link. Teletext offers a new way to add additional information to video training without affecting the current video distribution network.

# What is Teletext?

## WHAT ABOUT ERROR CORRECTION?

The WST standard provides for two basic layers of error correction for page format Teletext, Hamming code is used for addressing, and parity for character data. The Hamming correction can catch both single and double bit errors, while the parity checking can resolve single bit errors. For Packet 31 transmissions, there is the addition of a 16 bit CRC check added to the end of the data packet, although this is optional. Both page format Teletext and Packet 31 could be encoded with 8 bit data allowing any third party protection format to be used.

## WHAT ARE TELETEXT PACKETS?

Packets are the actual data information with an assigned address. There are three basic types of packet in the WST standard, page headers, normal rows, and extension packets. Each has a specific assigned purpose and bit format:

## PAGE HEADERS – Packet Address 0

This packet contains page number and control information, plus 32 display characters including 'TIME'. It appears at the top of the display.

## NORMAL ROWS – Packet Address 1 – 23

These contain 32 bytes (40 bytes 625 line) of data defining a row of 32 (40) characters on the display. The address defines the vertical position of the row.

## EXTENSION PACKETS – Packet Address 24 – 31

Typically each has its own special function and is not directly displayed. They are used to enhance the performance of the more advanced decoders or to provide special data services.

There are a total of eight extension packet functions pre-defined under the WST standard. They are:

Packet Number	Function
Packet (row) 24	Page Extension
Packet (row) 25	Telesoftware
Packet (row) 26	Schedule Information & Page Related Redefinition
Packet (row) 27	Linked Pages (FLOF/FASTEXT)
Packet (row) 28	Page Related Redefinition
Packet (row) 29	Magazine Related Redefinition
Packet (row) 30	Broadcaster Data Services
Packet (row) 31	Independent Data Services (Multi-media)

With these extensions, Teletext can support a wide variety of functional services from programming a VCR to acquiring the latest software for a home or business computer.

## EXTENSION PACKET PROCESSING

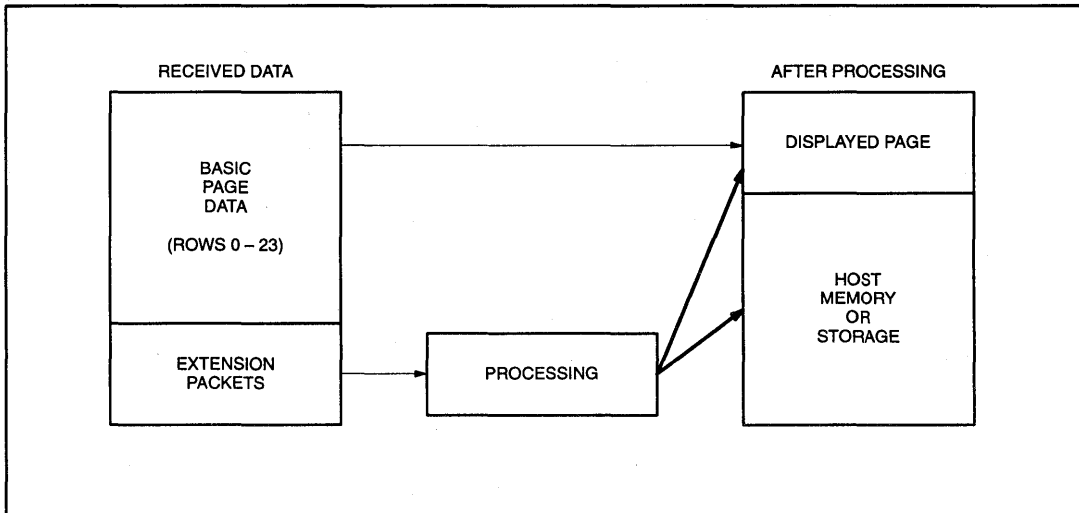

# What is Teletext?

## HOW DOES A DECODER FUNCTION?

There are two basic architectures to a WST decoder. The first is for standalone applications, as in a television set or a set-top decoder (Figure 5). These units are self contained and usually offer limited capabilities for extension packet handling. Generally the decoder is made up of a video input processor (VIP), the Teletext processor, some form of page memory storage for received data, a character generator to drive a CRT, and a character language font ROM for displaying the text in the native language the receiver is being used. These processors

offer a simple serial interface for communicating with the televisions microcontroller. Although the actual data usually can be removed via this interface, it is generally not recommend for performance reasons.

The second method for receiving Teletext data is to use a acquisition only decoder. This type of decoder relies on a host microprocessor to determine what happens to the received data once it has been acquired and error checked. At this point, the processor must handle all of the storage and display functions remaining to present the

data to the user. This is the preferred method used for teletext interacting with a personal computer. Because the host computer already has memory, disk, networking, and advanced display functions, there is no need to have these function duplicated in the Teletext receiver. (See Figure 6.)

Typically a decoder used in this method supports all of the packets described under the WST standard. The text processor is a minimal Teletext decoder only handling the error correction and acquisition functions. It is therefore quite flexible in supporting multiple packet format reception.

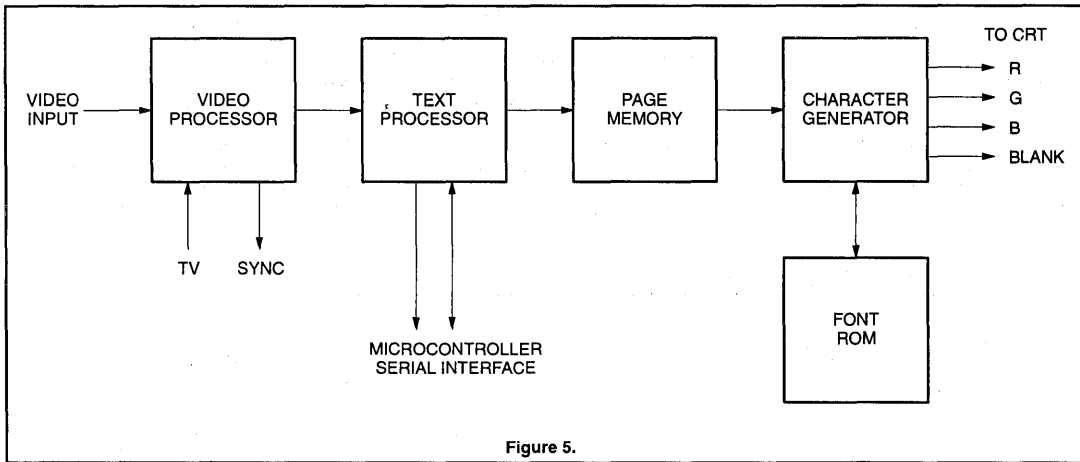

Figure 5.

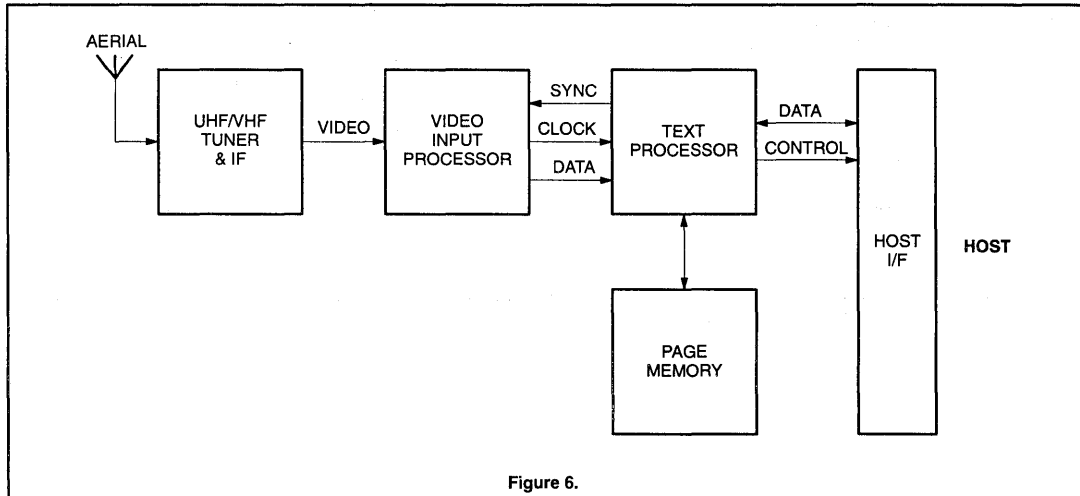

Figure 6.

# What is Teletext?

## WHAT ARE SOME RECOMMENDED CONFIGURATIONS?

For basic level 1 Teletext reception in the 525 line television system, the standard configuration is comprised of the SAA5191 data slicer, SAA9042 WST Teletext decoder, a DRAM for local storage, and either a microcontroller as the control host or and I2C

UART to interface to an external host (i.e., a microcomputer). This solution will not decode Packet 31 transmissions but will decode all other extension packets.

Figure 7 demonstrates a standalone decoder with the acquisition and display sections of the SAA9042 timed from the incoming video signal. Although this will work quite well for set-top or computer add-in card applications,

it should be noted that in the absence of any incoming composite sync signal, or if the signal is very noisy, the field sync integrator in the acquisition section will not be able to detect the start of the field. Consequently the display section will not receive a reliable vertical trigger, and thus a stable text display cannot be guaranteed under all signal conditions.

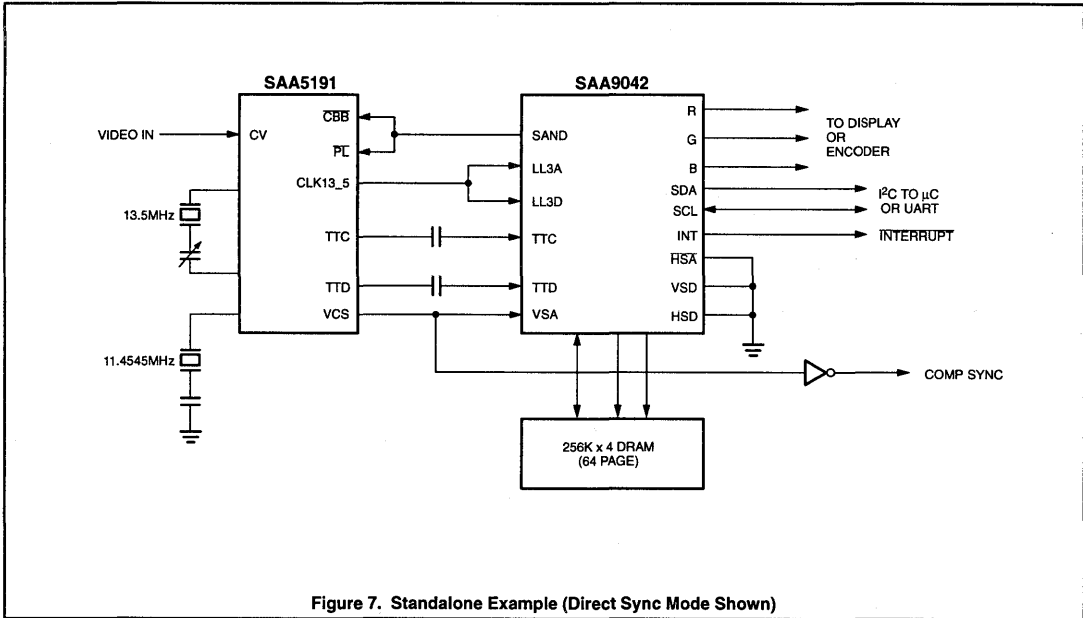

Figure 7. Standalone Example (Direct Sync Mode Shown)

# What is Teletext?

For acquisition only and Datacast reception (packet 31), the SAA5250 CMOS Interface for Data Acquisition and Control, or CIDAC, is a WST decoder designed for direct interfacing to a microprocessor host. Unlike the SAA9042, CIDAC only has one acquisition channel and support for only a 2Kx8 static RAM for local buffering. But because CIDAC was intended to interface to a microprocessor, the need for most of the larger local storage and multiple acquisition channels are unnecessary in this application since the microcomputer host has superior storage and data transfer capabilities already. In the circuit shown in Figure 8, the SAA5231 is used purely as a data slicer since the CIDAC doesn't require a dot clock for display the VCO section of the SAA5231 is left unused. Because the CIDAC was design as a multi-Teletext format decoder, the chip was designed primarily for full field data reception. For VBI applications, it is suggested to add a simple circuit between the SAA5231 and the CIDAC that creates a VBI 'window'.

The purpose of the VBI window generator is simple. To aid the CIDAC in the reduction of invalid data being processed, and to provide the host microprocessor with a data valid interrupt so the microprocessor will not be required to poll the CIDAC on a regular basis to determine if new data has arrived.

The TDA4820T is an adaptive sync separator which provides the PLD with vertical and composite sync. With these signals at hand, the PLD simply counts the number of horizontal lines after the vertical sync period until the desired active video line for the window to open is found. Upon finding this, the PLD then allows the data from the SAA5231 to be passed onto the CIDAC, but not before it is gated with the composite blanking signal first. This has the result of passing only valid data for a select number of horizontal lines and pre-filtering out any sync or color burst information which could be confused as valid data.

The other function the PLD generates is a simple interrupt pulse for the microprocessor. This pulse can be generated before, during, or after the window closes. The choice is up to the PLD's designer and is important for the microprocessors best performance. In addition, it is recommended that the PLD designer add a hardware select line from the PLD to the microprocessor to allow it to select full field or VBI reception for flexibility.

In conclusion, the WST Teletext format allows a system designer great flexibility while providing a low cost means to deliver secure data over a wide area network. Philips Semiconductors has been providing complete Teletext solutions since the formats early beginning and as a customer you can look forward to continued innovative and cost effective solutions from Philips Semiconductors, World wide supplier of Teletext components.

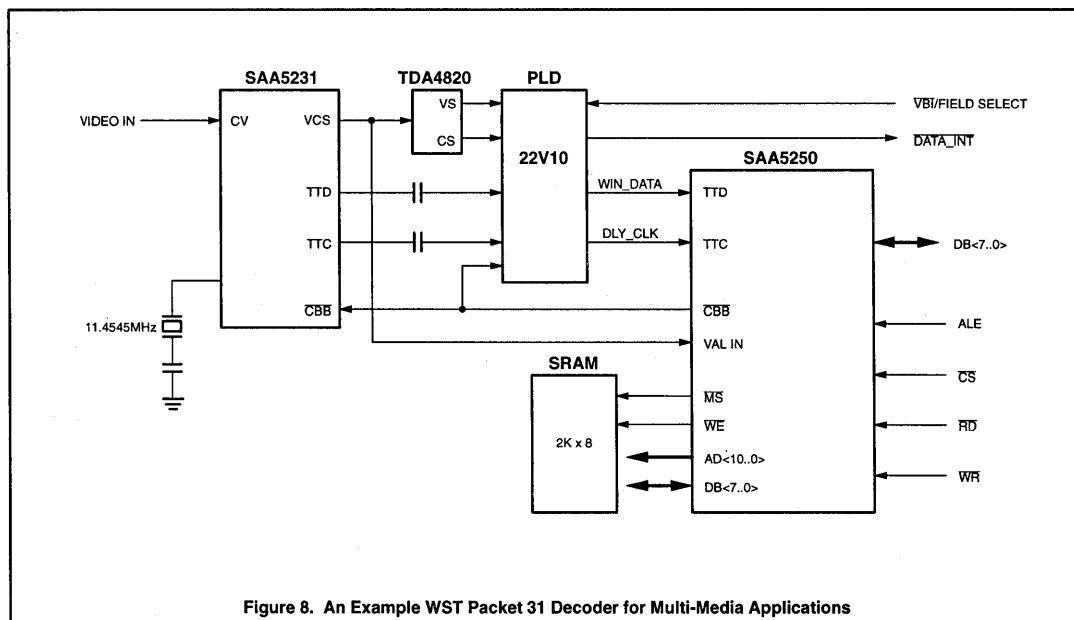

Figure 8. An Example WST Packet 31 Decoder for Multi-Media Applications



## Packet and Page Teletext data reception using the SAA5250

Authors: J.R. Kinghorn Philips Product Concept & Applications Lab, Southampton England  
A. Guenot Philips Semiconductors, Paris France

Revised: M. T. Schneider Philips Product Concept & Applications Lab, California

### SUMMARY

Two methods of transmitting serial data in World System Teletext (WST) format are available. These are the independent data line or 'Packet 31' method, and the page format technique. For universal application in a subscription Teletext environment the receiving equipment must be able to accept both forms of transmission. The Multistandard acquisition circuit CIDAC (SAA5250) or CMOS Interface for Data Acquisition and Control, is available to simplify the receiver design.

### INTRODUCTION

Recently there has been a great upsurge in interest in using Teletext to transmit serial data. This can be achieved without interfering with the normal Teletext service, and the data

can be used for many purposes. For instance, a nationwide one way data distribution service could provide customer support for a computer software manufacture, sending both new product announcements, software updates and bug fixes automatically.

At the receiving end, a variety of terminal equipment types can be envisaged depending on the application. A common requirement, however, is for a 'black box' which can be connected to an aerial input signal and deliver a parallel data output to a desktop computer. This unit can be largely transparent to the application, being the equivalent of a data link in a conventional wired computer installation. A block diagram of such an adapter unit is shown in Figure 1.

The UHF or VHF aerial signal is passed

through the conventional television receiving circuitry of tuner, I.F., and demodulator stages to produce a baseband composite video signal (CVBS). This is applied to the Teletext data slicer and acquisition decoder, which provides a data output to the host computer rather than the usual text display output.

The Teletext decoder can use a microprocessor to format the data output and provide control of the system. Tuning in the local broadcast station and selection of the required service can be done through the controls on the adapter unit, or alternatively by sending commands from the host computer through a suitable interface logic. Facilities for descrambling the data and access control can be provided in the software of the adapter unit or in the host computer according to the particular requirements of a service.

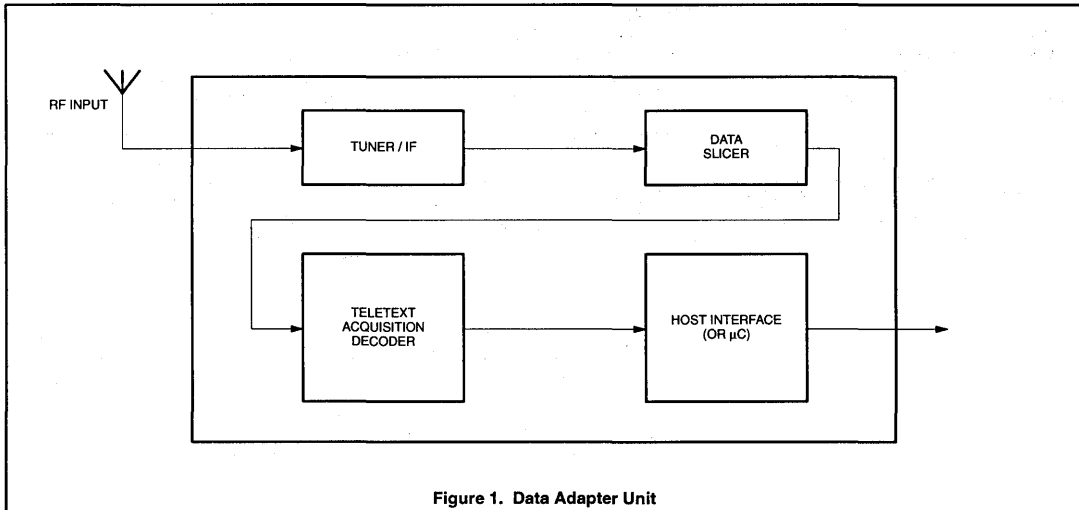

# Packet and Page Teletext data reception using the SAA5250

## The Teletext Decoder

As mentioned earlier, the requirements for a Teletext decoder to receive serial data are quite different from a conventional decoder in a television set, or set-top decoder. To begin with, an RGB text display output is not usually required as perfectly adequate character generating capacity is available on the host computer's display. The data output is the main requirement, demanding reasonably direct access to the acquisition memory from the host. Facilities for access control and descrambling the data may be needed, together with special error-checking algorithms.

As a further complication, two entirely different transmission methods are used for serial data; the page format method and the independent data line or 'packet 31' method. Each of these methods has its advantages and disadvantages, but it appears likely that both will be used commercially.

If only page format data reception is required, a standard Teletext decoder chip can be used with appropriate control software, see Reference 1. However, the adapter designer may require a universal decoder capable of operating on either form of transmission. For reasons of economy, duplication of circuitry should be avoided if possible. On the other hand, good

performance (i.e. speed) and adaptability may be prerequisites in a competitive design.

The multistandard acquisition circuit CIDAC (SAA5250) provides a solution to these problems. Originally designed for the reception of the French ANTIOPE and the World System Teletext formats, it is equally capable of acquiring data using the independent data line transmission technique. The device can be programmed to operate in various modes and two of these are suitable for the independent data line and the page format transmissions respectively. A block diagram of a multistandard Teletext decoder for serial data is shown in Figure 2.

Composite video is supplied to a standard Philips data slicer (SAA5231 or SAA5191) circuit which performs adaptive data slicing and supplies serial data and clock to the CIDAC (SAA5250). The other section of the data slicer is concerned with display timing synchronization is not used. All of the CIDAC timing is derived from the 5.7273Mhz (6.9375Mhz in 625 line) data clock. Acquisition of the data is performed by the CIDAC circuit (SAA5250).

The received data is buffered in a standard low cost 2K x 8 static RAM connected to the CIDAC. The chip performs appropriate prefix processing according to the operating mode selected, and the storage of particular

packets of data is under software control. Data is retrieved from the RAM via CIDAC's parallel interface to a host interface or a microcontroller.

If a microcontroller is used, the microcode is responsible for formatting the data into the form required to interface with the host computer (i.e. an RS-232 serial interface at 9600 baud). The microcontroller itself can be one of several standard types, 8051, 8049, 6801, 6805, etc. Any controls (i.e. to select the service) can be implemented locally in the decoder using port pins of the microcontroller; alternatively if the output interface is made bi-directional, selections can be made using the host computer externally. Access controls and descrambling are dealt with using the appropriate software in the decoder's microcontroller acting on the corresponding received data.

Alternatively, these functions may be performed by the host computer, with the decoder simply acting as a transparent data link and no microcontroller is used in this configuration. The same hardware configuration can be used as a receiver for downloadable software, or as a standard acquisition unit for normal World System Teletext or pages with the host computer used as the display unit.

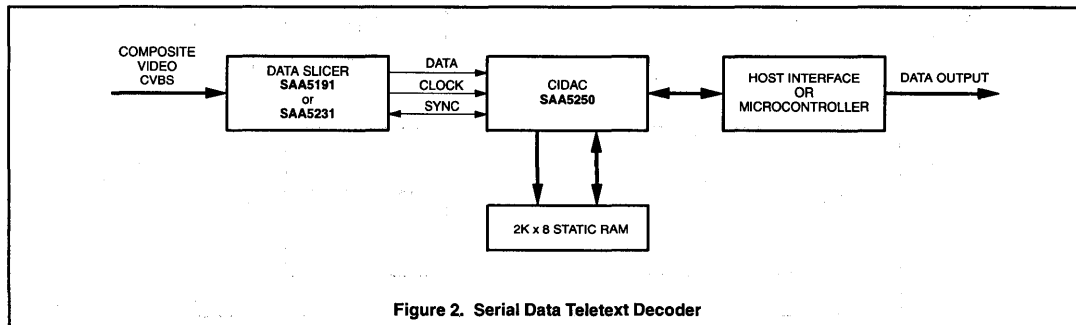

Figure 2. Serial Data Teletext Decoder

# Packet and Page Teletext data reception using the SAA5250

## The CIDAC Circuit

The CIDAC itself performs the acquisition functions and interfaces with the memory and host. A block diagram of the device is shown in Figure 3.

The received serial data from the data slicer is checked for framing code (which is programmed from the host) during a line timing window derived from the VCS sync signal. This timing window can be moved within limits under software control to compensate for the different framing code delays. After detection of the framing code, the information is converted into 8 bit parallel form. In addition, the VAL OUT output (pin 2) will reflect the position of the programmed framing window.

The functions performed by the data depend on the operating mode selected, and are controlled by the sequence controller circuit.

Some data bytes are *Hamming* protected, and these are passed through Hamming correction logic. Most of the operating modes have hardware recognition of a channel or *magazine*, so the appropriate input data is compared with the requested magazine number in the channel comparator. This ensures that only data from the selected magazines is loaded into memory, and that the acquisition process is not burdened with irrelevant data.

The format counter is used to count the number of bytes loaded into memory on each data line; this value can be loaded by the software. In long and short Didon (ANTIOPE) modes this information is taken from the broadcast format byte via the format transcoder.

Storage of the data in memory also depends on the selection of *slow* or *fast* mode. In slow mode, all data from the selected magazine is

stored in memory regardless of any further conditions. It is then up to the host software to search for the appropriate data by looking for a start-of-page flags, packet number recognition, etc. This method is suitable for modest operating speeds such as the packet 31 system, in which the host has no difficulty in keeping up with the overall data throughput.

Alternatively if fast mode is chosen, data is only stored after recognition by the CIDAC hardware of an appropriate 'start-of-page' flag. This flag depends on the system; codes SOH, RS for Didon, a bit in the PS byte for NABTS, or row 0 (page header) for World System Teletext. Using fast mode considerably simplifies the host's task in page recognition, so the position of the data to be checked becomes defined in memory. Fast mode is implemented by page flag detection circuitry in the sequence controller.

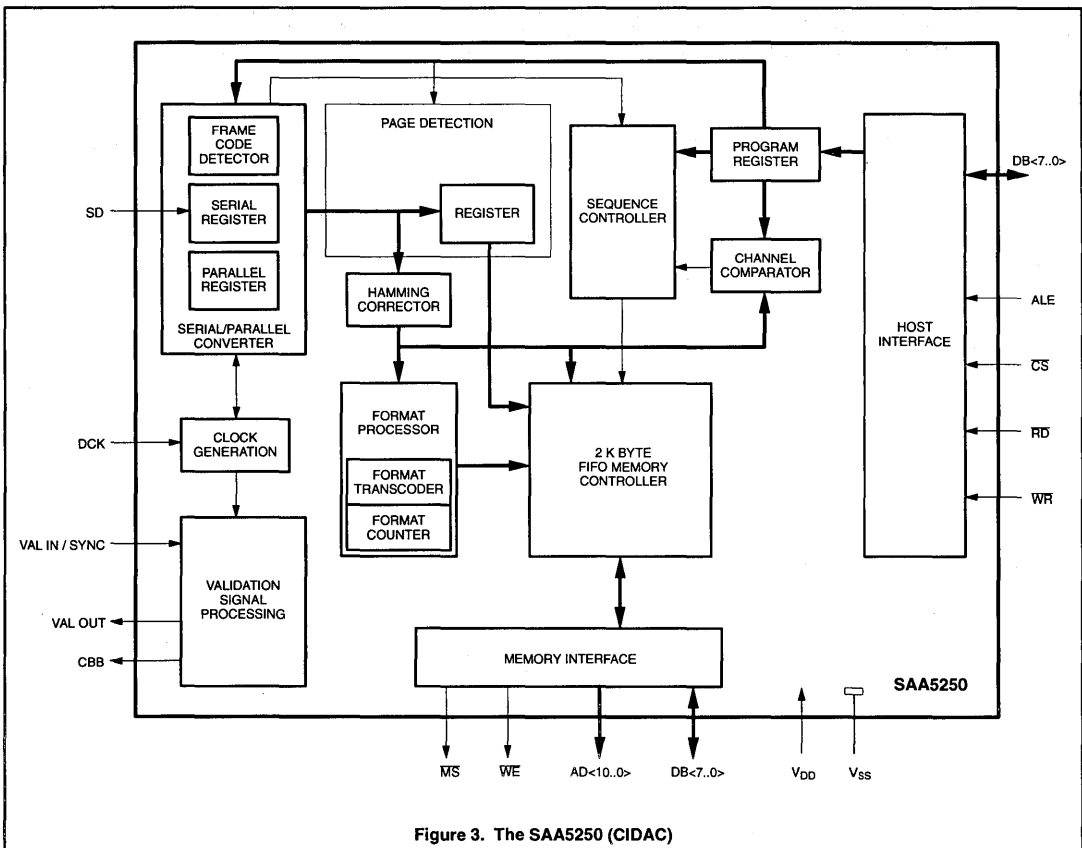

Figure 3. The SAA5250 (CIDAC)

## Packet and Page Teletext data reception using the SAA5250

Fast mode is suitable for the page format data transmission method, as the data may be mixed up with a large number of normal teletext pages and interleaved in time. With a suitably fast host, slow mode could be used but it should be remembered that the number of data lines transmitted might increase over time. Also, genuine full channel operation will be impossible in slow mode.

The external 2K x 8 static RAM is used as a first-in-first-out (FIFO) memory so that the transmission order is carefully preserved. Flags associated with the FIFO controller allow the host to see whether the FIFO is empty, has a character for reading, or it is full. Writing to the memory depends on the reception of transmitted data. And a read cycle occurs when it's requested by the host.

The CIDAC memory interface has interleaved read and write cycles clocked at the transmission rate, so in principle the host could read the data as fast as it is coming into the FIFO (Approx. one byte/microsecond). Any standard 2K x 8 Static RAM (i.e. 6116) can be connected to

the memory interface and the timing requirements are not very critical.

The interface to the host is an 8 bit parallel bus together with the appropriate handshaking control signals. Data and address are multiplexed on the bus in accordance with normal microprocessor practice. A feature of the CIDAC is the support of a MOTEL (Motorola/Intel) parallel (programmable) host interface.

The Intel protocol (i.e., 8051, 8049, etc.) latches the address with ALE, and has separate RD\* and WR\* pulses for reading and writing respectively. The Motorola protocol (i.e. 6801, 6805) has an AS pulse for latching addresses, a DS pulse every cycle, and a R/W\* signal to distinguish read and write cycles.

CIDAC distinguishes between these two protocols by looking at the state of the RD (DS) line during the ALE (AS) pulse and switches over automatically as necessary. This facility permits many types of host interfaces to be connected to CIDAC without extensive interface bus translation

components. Communication between the host and CIDAC is *always* initiated by the host.

Since CIDAC does not provide an interrupt function to the host, the host must poll to CIDAC to see when new data has arrived. However, the designer can generate a field interrupt easily by adding only a small amount of external logic.

Various write registers in CIDAC allow the selection of the operating mode, and the loading of the channel number. There are two registers which can be read by the host; the data register (which contains the next byte of data read from the FIFO memory by the CIDAC hardware), and a status register to indicate whether the FIFO memory is empty, normal, or full.

The rate of reading the FIFO depends *entirely* on the host, as it is asynchronous compared to the transmission. However, the software designer must ensure that, on average, the host reads the FIFO at least as fast as the data is arriving, otherwise the buffer can overflow.

# Packet and Page Teletext data reception using the SAA5250

## Data Formats

CIDAC is capable of receiving data in various formats, with options for Didon (ANTIOPE), NABTS, and World System Teletext reception. For the purpose of this paper, however, only two operating modes need concern us. These comprise the 'Didon medium prefix slow' mode, used for 'packet 31' transmissions and 'WST fast' mode for page format data reception (previously known as the UK 'CEEFAX' Teletext format). These data formats are shown in Figure 4.

The Didon medium prefix format (Figure 4a) has simply two channel address bytes after the framing code, followed by user data. The channel bytes are each 8/4 Hamming protected and use the same algorithm for Didon and WST.

For reception of World System Teletext, CIDAC has a 'WST fast' mode (Figure 4b) with three bits of the first byte used as a channel address or 'magazine' number. The remaining bit and subsequent byte form five

bits corresponding to the row address. Detection of the Row 0 (page header) in fast mode is the page flag indicating the storage of subsequent data in the FIFO.

The reception software **must** examine the data at the start of the sequence to determine the page number. If the data is not the desired page, the software arranges a re-initialization of CIDAC to search for the next page header.

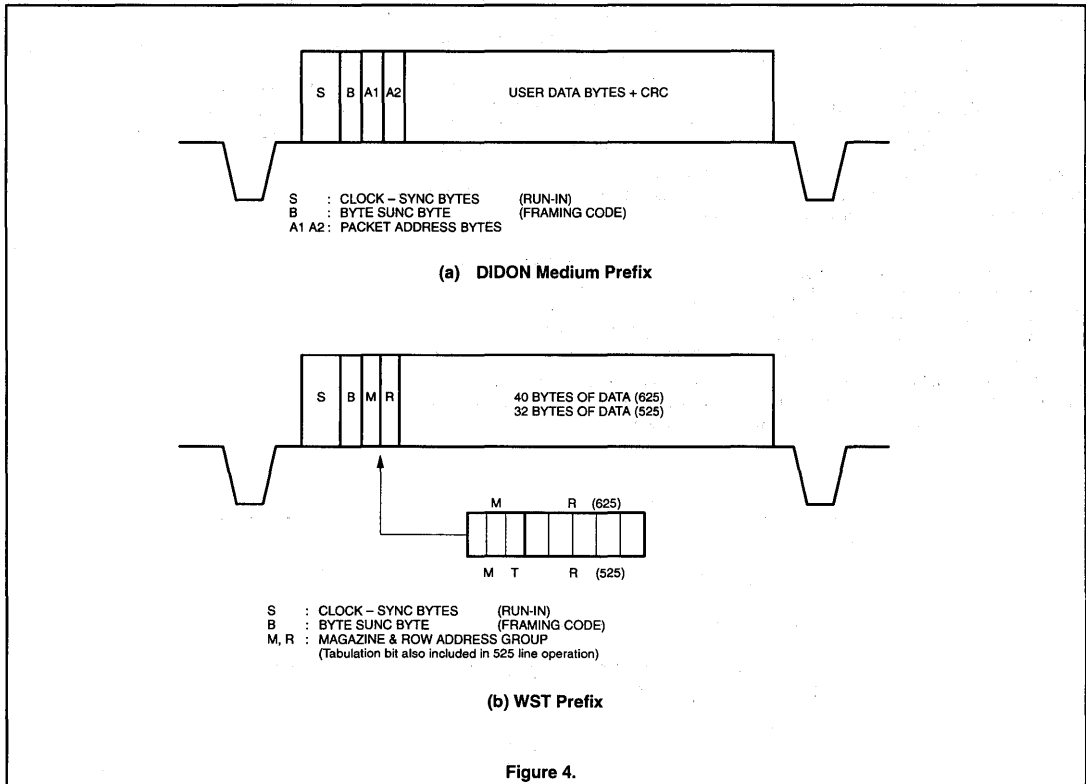

Figure 4.

# Packet and Page Teletext data reception using the SAA5250

## Receiving Datacast

Let us consider the use of CIDAC for receiving packet 31 transmissions in more detail. The Datacast specification (Reference 2), defines four independent data channels using message bits XX01 in the first byte following the framing code. With the second byte set to 1111, this is equivalent to packet 31, or magazine 8, 1, 2, or 3 in conventional (WST) teletext terms. The format is shown in Figure 5.

It will be recalled that CIDAC checks the first two bytes after the framing code in Didon medium Prefix mode, so this provides the means to select the data channel required. All subsequent bytes are stored in the FIFO and need to be processed by the host software. The Format Type byte (FT) indicates whether the Packet Repeat (RI) or Continuity Indicator (CI) bytes are present. Next, the packet Address Length byte (AL) indicates to the host how many bytes following are used to identify the packet address.

Following the bytes allotted for the packet address comes the optional Repeat Indicator (RI). The RI value indicates the number of times the packet has been transmitted (i.e. first, second, third, etc., repeat of packet). The Continuity Indicator (CI), which is again optional, increments at each transmission of a packet to a given address. This allows the

host software to detect the omission of a packet in the sequence.

Following the 'prefix' bytes, there is a sequence of between 28 to 32 (36 in 625 line) user data bytes used to convey the serial data. The data can be represented as either 8 or 7 bit (with parity) data. CIDAC can be set up to enable or disable the parity checking feature. When parity is enabled, the last bit of each byte is used by the software to detect a parity error in the data.

A 16 bit cyclic redundancy check (CRC) follows the user data at the end of the packet. This allows the integrity of the user data and the continuity indicator (CI) byte to be checked for any errors that may have occurred in transmission. As for the host software, the functions it needs to perform during packet 31 reception fall into three broad categories of operation, they are:

### Initialization

The initialization process for the CIDAC will need to select the proper operating mode. An example might be:

- Didon medium prefix slow mode
- No parity checking
- The desired data channel
- A framing code value
- Sync delay time & sync pulse width.

This procedure will cause CIDAC to acquire all packet 31 transmissions for a specified data channel.

## Recognition

A software routine must be written to handle the recognition of the desired packet address in the data stream. This involves checking the Address Length (AL) and packet address bytes to identify the desired service. If a correspondence is not found, the routine can rapidly unload the incorrect user data bytes from the FIFO (without processing it), before the next data packet arrives and the checking process is restarted.

## Formatting & Error Checking

The last step is to handle the formatting and error checking functions once the desired data packet is located. To do this, the routine has to:

- Check the Format Type (FT)
- The Repeat Indicator (RI) byte
- The Continuity Indicator (CI) byte
- Handle CRC check on the Data

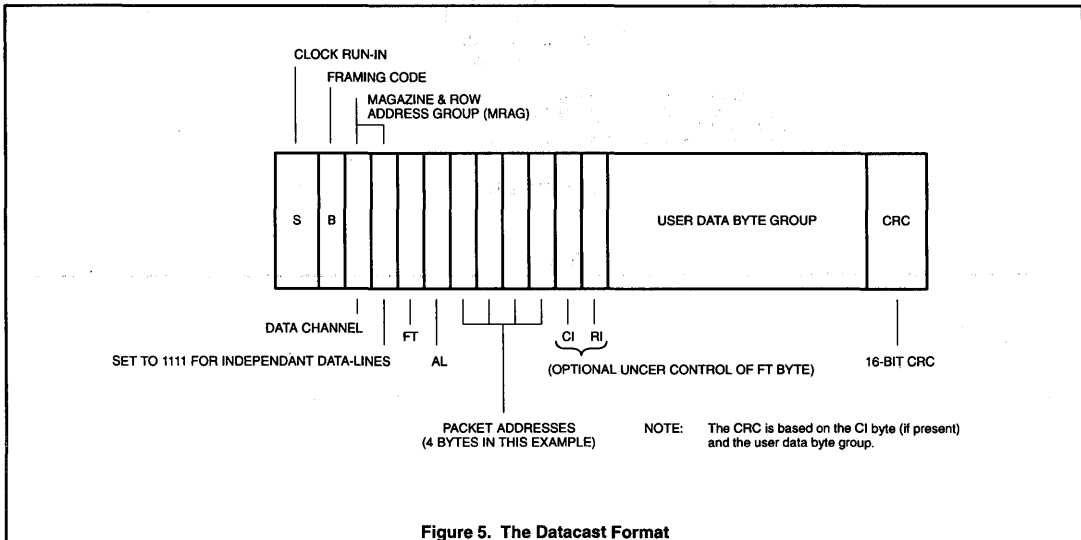

# Packet and Page Teletext data reception using the SAA5250

If the Repeat Indicator is in use, the software should arrange temporary buffering of the multiple transmissions of data and make a choice on the basis of the comparisons, plus the CRC check, as to which data is valid. The data must only be sent to the host once from the decoder if the proper data sequence is to be preserved. The Repeat Indicator is used by the software routine to ensure that repeated data is not sent out to the host again. A simplified flow chart can be found in Figure 6.

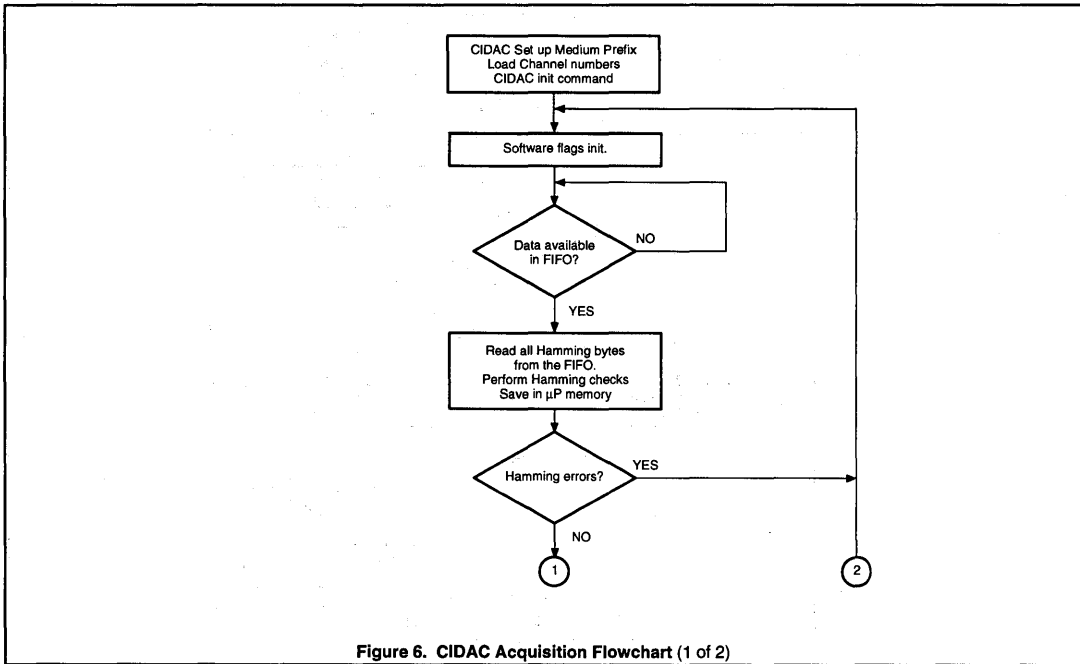

# Packet and Page Teletext data reception using the SAA5250

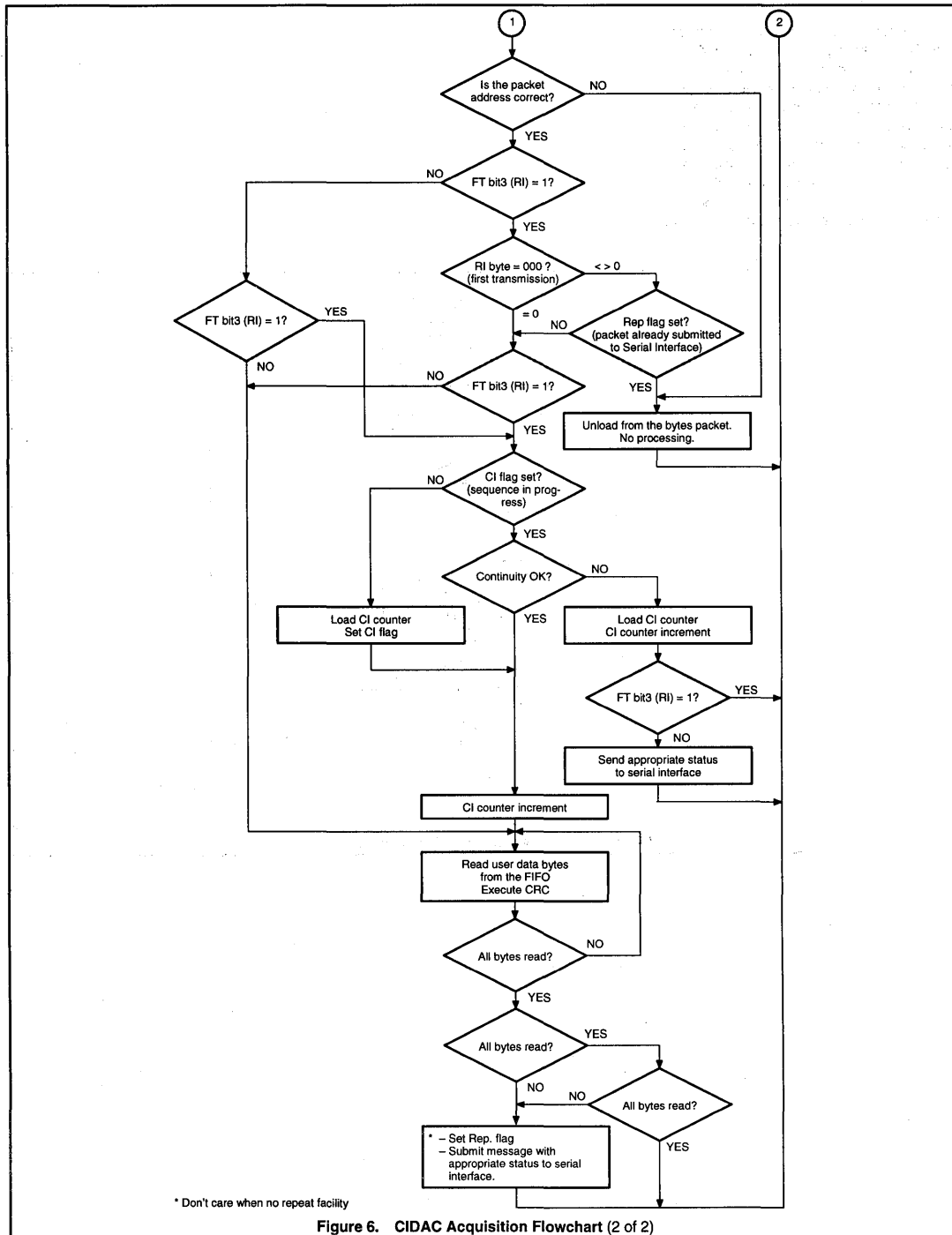

Figure 6. CIDAC Acquisition Flowchart (2 of 2)



---

## Packet and Page Teletext data reception using the SAA5250

---

### CONCLUSION

The CIDAC decoder can form the basis of an acquisition only Teletext decoder operating on both the 'page format' and the 'Packet31' types of transmission. With suitable software, a high performance and efficient design can be achieved.

### REFERENCES

1. Tarrant, David R. 'Data Link Using Page-Format Teletext Transmissions', IERE, Electronic Delivery of Data and Software Conference. September 1986.
2. BBC Datacast Technical Specification, 1985.

**Special Note:** The SAA5243 (CCT) mentioned in Reference 1 is no longer in production. A suitable replacement can be found in the table below:

#### **625 line only**

SAA 5244A  
SAA 5246A  
SAA 5247  
SAA 5248  
SAA 5249  
SAA 5254  
SAA 5280

All of the above parts include a built-in data slicer, therefore no need for a SAA5231 data slicer.

#### **525/625 line**

SAA 9042 + SAA 5191  
SAA5296

### RECOMMENDED READING

*'World System Teletext and Data Broadcasting System Technical Specification'*. December 1987, United Kingdom Department of Trade and Industry, London England.

*'Digital Video Signal Processing'*. June 1988. Philips Components publication No. 9398 063 30011

Data Sheets for the Philips SAA5191 & SAA5231 Data Slicers (available from your local Philips Semiconductors Salesman).

Data Sheet for the SAA5250 CMOS Interface for Data Acquisition and Control (CIDAC).

Data Book of the I<sup>2</sup>C controlled television tuner front-end Modules, Philips Components publication No. 9398 182 50011

# Packet and Page Teletext data reception using the SAA5250

## APPENDIX A

### CIDAC Operating Modes for World System Teletext

#### 1. WST (CEEFAX) Teletext Mode

Set up Magazine number in the 3 LSB's of Register 1.

SLOW mode: All data from magazine stored.

FAST mode: All data from magazine stored once Row 0 is detected.

#### 2. DIDON Medium Prefix Mode (packet 31)

Set up magazine number in the 3 LSB's of Register 1.

Set up Row number in 4th LSB of Register 1 and the 4 LSB's of Register 2.

SLOW mode: All data from magazine with a specific packet number is stored.

FAST mode: Not valid for World System Teletext reception.

#### 3. No Prefix Mode

No set up.

All data of every magazine and packet number is stored.

## APPENDIX B

### CIDAC Register Address Mapping

Below is the addressing definition for access to the CIDAC registers.

ADDRESS						ADDRESS CIDAC REGISTER
R	W	CS	DB2	DB1	DB0	
H	L	L	L	L	L	Write Register R0
H	L	L	L	L	H	Write Register R1
H	L	L	L	H	L	Write Register R2
H	L	L	L	H	H	Write Register R3
H	L	L	H	L	L	Write Register R4
H	L	L	H	L	H	Write Register R5
H	L	L	H	H	L	Write Register R6 (used for CIDAC init only)
H	L	L	H	H	H	Write Register R7
L	H	L	L	L	L	Read Status Register
L	H	L	L	L	H	Read Data Register
L	H	L	L	H	L	Not Used
L	H	L	L	H	H	Not Used

## Packet and Page Teletext data reception using the SAA5250

### APPENDIX C

#### CIDAC Register Organization

##### CIDAC WRITE REGISTERS

FUNCTION	REGISTER	DATA BYTE							
		D7	D6	D5	D4	D3	D2	D1	D0
mode & parity	00	X	X	X	mode	parity	prefix2	prefix1	prefix0
format	01	val	fmt2	fmt1	fmt0	fstdgt3	fstdgt2	fstdgt1	fstdgt0
channel number	02	thdgt3	thdgt2	thdgt1	thdgt0	scdgt3	scdgt2	scdgt1	scdgt0
hamming	03	X	X	max5	max4	max3	max2	max1	max0
frame code	04	val7	val6	val5	val4	val3	val2	val1	val0
sync process	05	pol	del6	del5	del4	del3	del2	del1	del0
init register <sup>1</sup>	06	X	X	X	X	X	X	X	X
burst blanking	07	X	X	bst5	bst4	bst3	bst2	bst1	bst0

**NOTE:**

1. This is a fictitious register. Only the address needs to be accessed to reset CIDAC.

##### CIDAC READ REGISTERS

FUNCTION	REGISTER	DATA BYTE							
		D7	D6	D5	D4	D3	D2	D1	D0
FIFO status	00	X	X	X	X	X	DB2	DB1	DB0
FIFO data	01	D7	D6	D5	D4	D3	D2	D1	D0
NOT USED	02	X	X	X	X	X	X	X	X
NOT USED	03	X	X	X	X	X	X	X	X

### APPENDIX D

#### Suggested Data Slicer Components for 625/525 Line Operation

The examples in this application note were designed for operation in both 625 and 525 line Teletext systems. Depending on which line standard is chosen, some of the peripherals commonly around the data slicer need to be adjusted for proper operation. The table below shows these values:

PIN NUMBER	PIN NAME	VALUE WITH SAA5250		VALUE WITH SAA9042	
		525 LINE	625 LINE	525 LINE	625 LINE
5	Store Amplitude	560 pF	470 pF	560 pF	470 pF
8	Data Timing	470 pF	390 pF	330 pF	270 pF
9	Store Phase	270 pF	220 pF	120 pF	100 pF
11	Crystal	11.4545 MHz	13.875 MHz	11.4545 MHz	13.875 MHz
12	Clock Filter	39 pF	27 pF	39 pF	27 pF

---

## Packet and Page Teletext data reception using the SAA5250

---

### CRYSTAL SPECIFICATION

**Quartz Crystal**    **11.4545MHz** (525 line)  
                          **13.875MHz** (625 line)

Nominal Frequency	11.4545 MHz
Frequency Tol @ 25°C	+/- 50ppm
Temperature Stability	+/- 30ppm
Temperature Range	-20 to +70°C
Load Capacitance (CL)	15pF
Shunt capacitance (Co)	5 pF typical, 7pF Max.
Motion Capacitance (C1)	19 fF typical
Resonance resistance (Rr)	10 Ohms typical, Max. 60 Ohms
Aging	+/- 5ppm/year
Mode of operation	Fundamental
Drive Level	100 $\mu$ Watts Correlation

### SUPPLIERS

The crystals above can be ordered from the Philips Components Passives Group, the part numbers are:

4322 143 04890 (13.875MHz)

For 11.454, contact Philips Passives.

The Component Passive group can be reached at (803) 772-2500.

The crystals are also available from Ecliptek inc. Their part numbers are:

ECX - 2384 - 11.454MHz.

ECX - 2383 - 13.875MHz

ECX - 2382 - 13.500MHz (not used with the SAA5250, but listed for reference)

Ecliptek can be reached at (714) 433-1200. The contact sales representative is Mr. Rodney Mills.

# Section 3

## Functional Index of Products

## CONTENTS

**Analog-to-digital conversion**

Analog-to-digital converter selection guide .....	3-3
TDA8703 8-bit high-speed analog-to-digital converter .....	3-790
TDA8706 6-bit analog-to-digital converter with multiplexer and clamp .....	3-803
TDA8707 Triple RGB 6-bit video analog-to-digital interface .....	3-813
TDA8708A Video analog input interface .....	3-825
TDA8708B Video analog input interface .....	3-842
TDA8709A Video analog input interface .....	3-859
TDA8712; TDF8712 8-bit digital-to-analog converters .....	3-878
TDA8714 8-bit high-speed analog-to-digital converter .....	3-893
TDA8716 8-bit high-speed analog-to-digital converter .....	3-908
TDA8718 8-bit high-speed analog-to-digital converter .....	3-924
TDA8755 YUV 8-bit video low-power analog-to-digital interface .....	3-933
TDF8704 8-bit high-speed analog-to-digital converter .....	3-1033
TDA8758 YC 8-bit low-power analog-to-digital video interface .....	3-948
TDA8760 10-bit high-speed analog-to-digital converter .....	3-963

**Auxiliary functions**

PCF8574/PCF8574A Remote 8-bit I/O expander for I <sup>2</sup> C-bus .....	3-5
PCF8584 I <sup>2</sup> C-bus controller .....	3-16
SAA1101 Universal sync generator (USG) .....	3-41
SAA5252 Line twenty-one acquisition and display (LITOD) .....	3-100
TDA2595 Horizontal combination .....	3-644
TDA4670 Picture signal improvement (PSI) circuit .....	3-675
TDA4680 Video processor with automatic cut-off and white level control .....	3-685
TDA4686 Video processor, with automatic cut-off control .....	3-701
TDA4820T Sync separation circuit for video applications .....	3-717
TDA8444/AT/T Octuple 6-bit DAC with I <sup>2</sup> C-bus .....	3-722
TDA8446; TDA8446T Fast RGB/YC switch for digital decoding .....	3-731
TDA8540 4 × 4 video switch matrix .....	3-763

**Analog color decoding**

TDA3566A PAL/NTSC decoder .....	3-651
TDA4665 Baseband delay line .....	3-669
TDA8501 PAL/NTSC encoder .....	3-738
TDA9141 PAL/NTSC/SECAM decoder/sync processor .....	3-1010

**Color decoding, encoding and clock ICs (digital)**

SAA7110 One Chip Frontend 1 (OFC1) .....	3-120
SAA7110 programming example .....	3-184
SAA7151B Digital multistandard colour decoder with SCART interface (DMSD2-SCART) .....	3-202
SAA7157 Clock signal generator circuit for digital TV systems (SCGC) .....	3-252
SAA7183 Digital video encoder (square pixel with Macrovision) .....	3-302
SAA7187 Digital video encoder (DENC2-SQ) .....	3-332
SAA7188A Digital video encoder (DENC2-M) .....	3-359
SAA7188A programming example .....	3-385
SAA7191B Digital multistandard colour decoder, square pixel (DMSD-SQP) .....	3-387
SAA7194 Digital video decoder and scaler circuit (DESC) ( <i>short-form data sheet</i> ) .....	3-454
SAA7196 Digital video decoder, scaler, and clock generator (DESCPro) .....	3-457
SAA7197 Clock signal generator circuit for Desktop Video systems (SCGC) .....	3-511
SAA7199B Digital video encoder, GENLOCK-capable .....	3-517
SAA9051 Digital multistandard TV decoder .....	3-575
SAA9057B Clock signal generator circuit for Digital TV systems (CGC) .....	3-619

## Digital-to-analog conversion

Digital-to-analog converter selection guide .....	3-4
SAA7165 Video enhancement and D/A processor (VEDA2) .....	3-276
SAA7169 35 MHz triple 9-bit D/A converter for high-speed video .....	3-295
SAA9065 Video enhancement and D/A processor (VEDA) .....	3-626
TDA8702 8-bit video digital-to-analog converter .....	3-776
TDA8771 Triple 8-bit video digital-to-analog converter .....	3-984
TDA8772; TDA8772A Triple 8-bit video digital-to-analog converter .....	3-996

## Digital video processing

SAA7116 Digital video to PCI interface .....	3-185
SAA7152 Digital video comb filter (DCF) .....	3-243
SAA7164 Video enhancement and D/A processor (VEDA3) .....	3-258
SAA7186 Digital video scaler .....	3-303
SAA7192A Digital colour space converter .....	3-418

## Teletext

SAA5191 Teletext video processor .....	3-52
SAA5231 Teletext video processor .....	3-58
SAA5250 Interface for data acquisition and control (for multi-standard teletext systems) .....	3-69
SAA5296 Single chip economy 10 page teletext/TV microcontroller .....	3-114
SAA9042 Multi-standard Teletext IC for standard and features TV .....	3-549

## A to D converter selection guide

Part	Resolution	Power	Convert Rate	Clamp	AGC	Number of Inputs	Outputs	Comments	Applications
TDA8703	8 bits	290mW	40MHz	No	No	One	Binary and Two's comp.	TTL compatible	General Purpose
TDA8706	6 bits (X3)	300mW	20MHz	Yes	No	Three multiplexed inputs	Binary TTL	Internal Reference	YUV, PIP applications
TDA8708A/B	8 bits	365mW	32MHz	Yes	Yes	One of three	Binary and Two's comp.	Peak white is 248 for 8708A 255 for 8708B	Video decoding, frame grabbers
TDA8709A	8 bits	380mW	32MHz	Yes	No	One of three	Binary and Two's comp.	Ext. voltage gain control	Video signal and chroma proc.
TDA8714	8 bits	325mW	75MHz	No	No	One	Binary and Two's comp.	7.6 effective bits at 4.43MHz	High speed applications: radar, medical, physics, etc.
TDA8716	8 bits	780mW	100MHz	No	No	One	Binary ECL with overflow	Comp. ECL clock	Very high speed ECL applications
TDA8718	8 bits	1140mW	600MHz	No	No	One	Binary ECL with overflow	Comp. ECL clock	Ultra high speed ECL applications
TDA8755	8 bits	565mW	20MHz	Yes	No	Three multiplexed inputs	Binary and Two's comp.	4:1:1 data encoder	YUV video conversion
TDA8758G	8 bits (X2)	475mW	32MHz	Yes	Yes	5	Two's comp.	TTL compatible white peak disable	Dual video A/D composite or S-Video
TDF8704	8 bits	365mW	50MHz	No	No	One	Binary and Two's comp.	-40, +85 temp range	Automotive/High temp. general purpose

## D to A converter selection guide

Part	Resolution	Power	Convert Rate (Max.)	Number of DACs/Package	Comments	Applications
TDA8702	8 bits	250mW	30MHz	One	75 $\Omega$ load	General purpose
TDA8712	8 bits	250mW	50MHz	One	75 $\Omega$ load	High speed general purpose
TDA8771	8 bits	175mW	35MHz	Three	3 volts p/p out into 1K $\Omega$	Triple output general purpose
TDA8772	8 bits	260mW 310mW	35MHz 85MHz	Three	75 $\Omega$ load, separate blanking and sync inputs	RGB or YUV video with sync on signal
TDA7169	9 bits		35MHz	Three	75 $\Omega$ load	RGB or YUV video
TDA7165	8 bits		30MHz	Three	Digital YUV to analog YUV converter with aperture and color improvement	Interfaces to RGB monitor drivers
TDA9065	8 bits		30MHz	Three	Digital YUV to analog YUV converter with aperture improvement	Interfaces to RGB monitor drivers



# Remote 8-bit I/O expander for I<sup>2</sup>C-bus

# PCF8574/PCF8574A



### GENERAL DESCRIPTION

The PCF8574 is a single-chip silicon gate CMOS circuit. It provides remote I/O expansion for the MAB8400 and PCF84CXX microcontroller families via the two-line serial bidirectional bus (I<sup>2</sup>C). It can also interface microcomputers without a serial interface to the I<sup>2</sup>C-bus (as a slave function only). The device consists of an 8-bit quasi-bidirectional port and an I<sup>2</sup>C interface. The PCF8574 has low current consumption and includes latched outputs with high current drive capability for directly driving LEDs. It also possesses an interrupt line (INT) which is connected to the interrupt logic of the microcomputer on the I<sup>2</sup>C-bus. By sending an interrupt signal on this line, the remote I/O can inform the microcomputer if there is incoming data on its ports without having to communicate via the I<sup>2</sup>C-bus. This means that the PCF8574 can remain a simple slave device. The PCF8574 and the PCF8574A versions differ only in their slave address as shown in Fig.9.

### Features

- Operating supply voltage 2.5 V to 6 V
- Low stand-by current consumption max. 10  $\mu$ A
- Bidirectional expander
- Open drain interrupt output
- 8-bit remote I/O port for the I<sup>2</sup>C-bus
- Peripheral for the MAB8400 and PCF84CXX microcontroller families
- Latched outputs with high current drive capability for directly driving LEDs
- Address by 3 hardware address pins for use of up to 8 devices (up to 16 with PCF8574A)

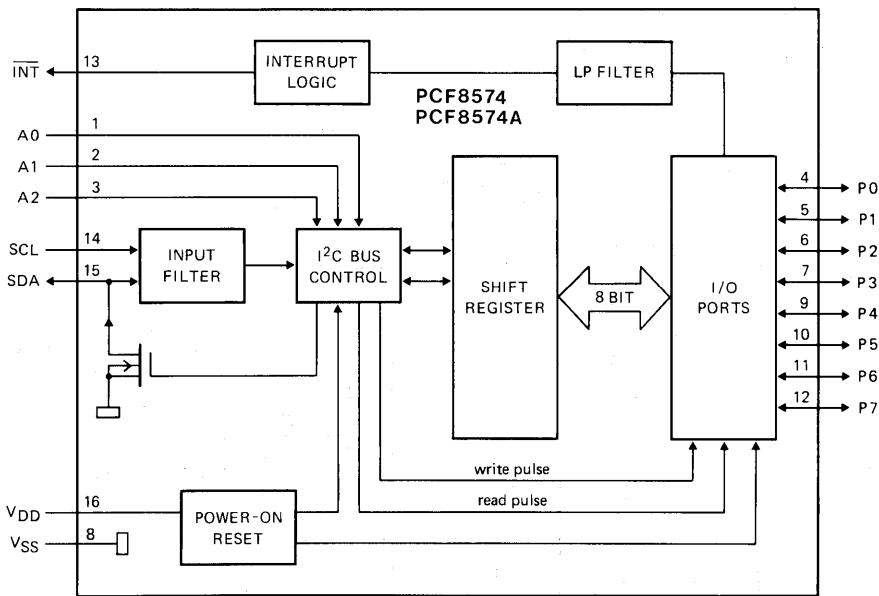

Fig.1 Block diagram.

### PACKAGE OUTLINES

PCF8574P, PCF8574AP: 16-lead DIL; plastic (SOT38).  
 PCF8574T, PCF8574AT: 16-lead mini-pack; plastic (SO16L; SOT162A).

# Remote 8-bit I/O expander for I<sup>2</sup>C-bus

# PCF8574/PCF8574A

## PINNING

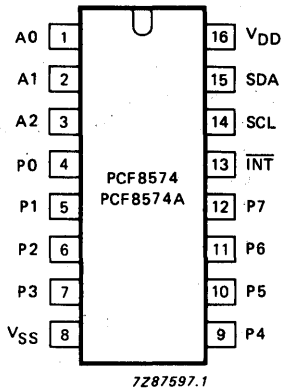

Fig.2 Pinning diagram.

- |         |                 |                                    |
|---------|-----------------|------------------------------------|
| 1 to 3  | A0 to A2        | address inputs                     |
| 4 to 7  | P0 to P3        | 8-bit quasi-bidirectional I/O port |
| 9 to 12 | P4 to P7        |                                    |
| 8       | V <sub>SS</sub> | negative supply                    |
| 13      | INT             | interrupt output                   |
| 14      | SCL             | serial clock line                  |
| 15      | SDA             | serial data line                   |
| 16      | V <sub>DD</sub> | positive supply                    |

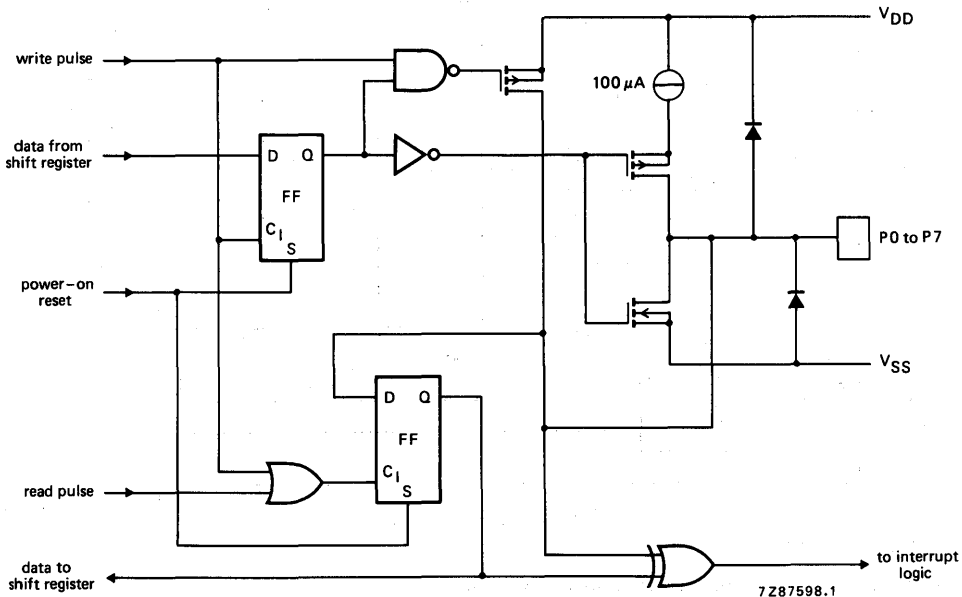

Fig.3 Simplified schematic diagram of each port.

# Remote 8-bit I/O expander for I<sup>2</sup>C-bus

# PCF8574/PCF8574A

## CHARACTERISTICS OF THE I<sup>2</sup>C-BUS

The I<sup>2</sup>C-bus is for 2-way, 2-line communication between different ICs or modules. The two lines are a serial data line (SDA) and a serial clock line (SCL). Both lines must be connected to a positive supply via a pull-up resistor when connected to the output stages of a device. Data transfer may be initiated only when the bus is not busy.

### Bit transfer

One data bit is transferred during each clock pulse. The data on the SDA line must remain stable during the HIGH period of the clock pulse as changes in the data line at this time will be interpreted as control signals.

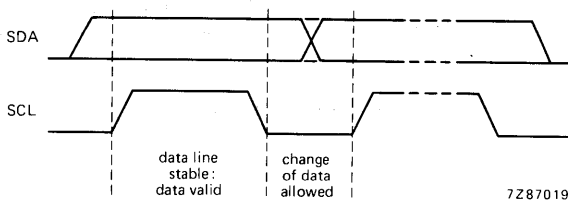

Fig.4 Bit transfer.

### Start and stop conditions

Both data and clock lines remain HIGH when the bus is not busy. A HIGH-to-LOW transition of the data line, while the clock is HIGH is defined as the start condition (S). A LOW-to-HIGH transition of the data line while the clock is HIGH is defined as the stop condition (P).

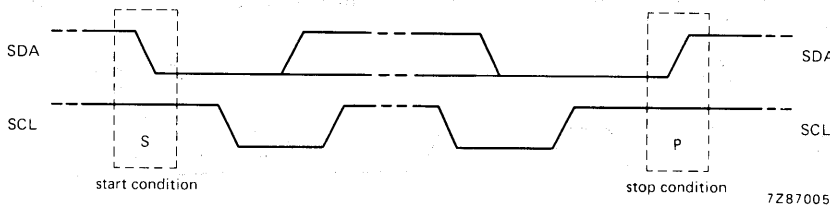

Fig.5 Definition of start and stop conditions.

# Remote 8-bit I/O expander for I<sup>2</sup>C-bus

# PCF8574/PCF8574A

## CHARACTERISTICS OF THE I<sup>2</sup>C-BUS (continued)

### System configuration

A device generating a message is a "transmitter", a device receiving a message is the "receiver". The device that controls the message is the "master" and the devices which are controlled by the master are the "slaves".

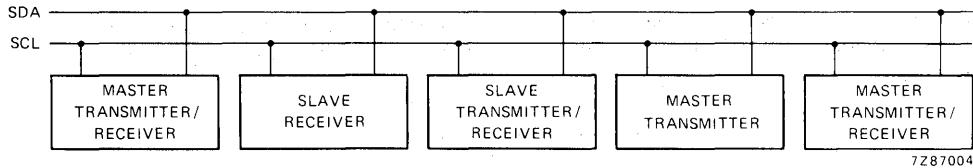

Fig.6 System configuration.

### Acknowledge

The number of data bytes transferred between the start and stop conditions from transmitter to receiver is not limited. Each byte of eight bits is followed by one acknowledge bit. The acknowledge bit is a HIGH level put on the bus by the transmitter whereas the master generates an extra acknowledge related clock pulse. A slave receiver which is addressed must generate an acknowledge after the reception of each byte that has been clocked out of the slave transmitter. The device that acknowledges has to pull down the SDA line during the acknowledge clock pulse, so that the SDA line is stable LOW during the HIGH period of the acknowledge related clock pulse, set up and hold times must be taken into account. A master receiver must signal an end of data to the transmitter by *not* generating an acknowledge on the last byte that has been clocked out of the slave. In this event the transmitter must leave the data line HIGH to enable the master to generate a stop condition.

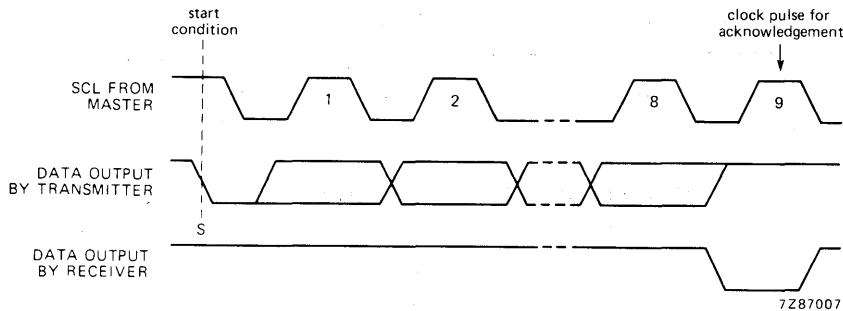

Fig.7 Acknowledgement on the I<sup>2</sup>C-bus.

# Remote 8-bit I/O expander for I<sup>2</sup>C-bus

# PCF8574/PCF8574A

## Timing specifications

All the timing values are valid within the operating supply voltage and ambient temperature range and refer to  $V_{IL}$  and  $V_{IH}$  with an input voltage swing of  $V_{SS}$  to  $V_{DD}$ .

parameter	symbol	min.	typ.	max.	unit
SCL clock frequency	$f_{SCL}$	—	—	100	kHz
Tolerable spike width on bus	$t_{SW}$	—	—	100	ns
Bus free time	$t_{BUF}$	4.7	—	—	$\mu$ s
Start condition set-up time	$t_{SU}; STA$	4.7	—	—	$\mu$ s
Start condition hold time	$t_{HD}; STA$	4.0	—	—	$\mu$ s
SCL LOW time	$t_{LOW}$	4.7	—	—	$\mu$ s
SCL HIGH time	$t_{HIGH}$	4.0	—	—	$\mu$ s
SCL and SDA rise time	$t_r$	—	—	1.0	$\mu$ s
SCL and SDA fall time	$t_f$	—	—	0.3	$\mu$ s
Data set-up time	$t_{SU}; DAT$	250	—	—	ns
Data hold time	$t_{HD}; DAT$	0	—	—	ns
SCL LOW to data out valid	$t_{VD}; DAT$	—	—	3.4	$\mu$ s
Stop condition set-up time	$t_{SU}; STO$	4.0	—	—	$\mu$ s

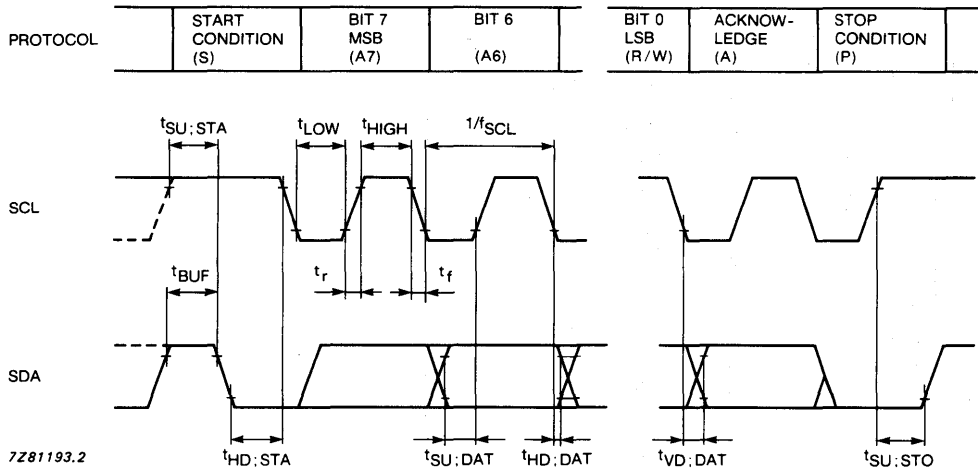

Fig.8 I<sup>2</sup>C-bus timing diagram.

**FUNCTIONAL DESCRIPTION**

**Addressing** (see Figs 9, 10 and 11)

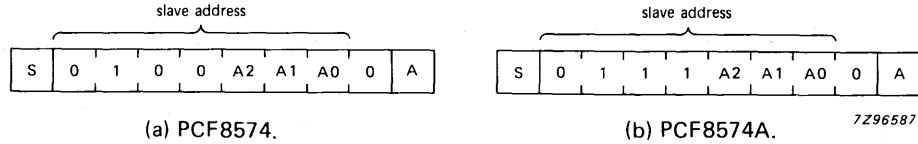

Fig.9 PCF8574 and PCF8574A slave addresses.

Each bit of the PCF8574 I/O port can be independently used as an input or an output. Input data is transferred from the port to the microcomputer by the READ mode. Output data is transmitted to the port by the WRITE mode.

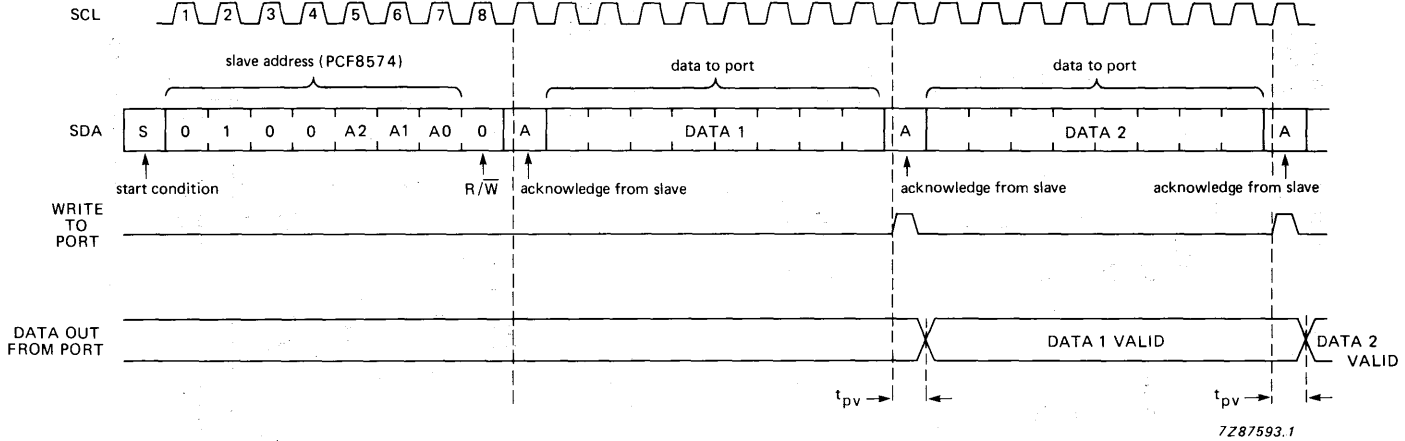
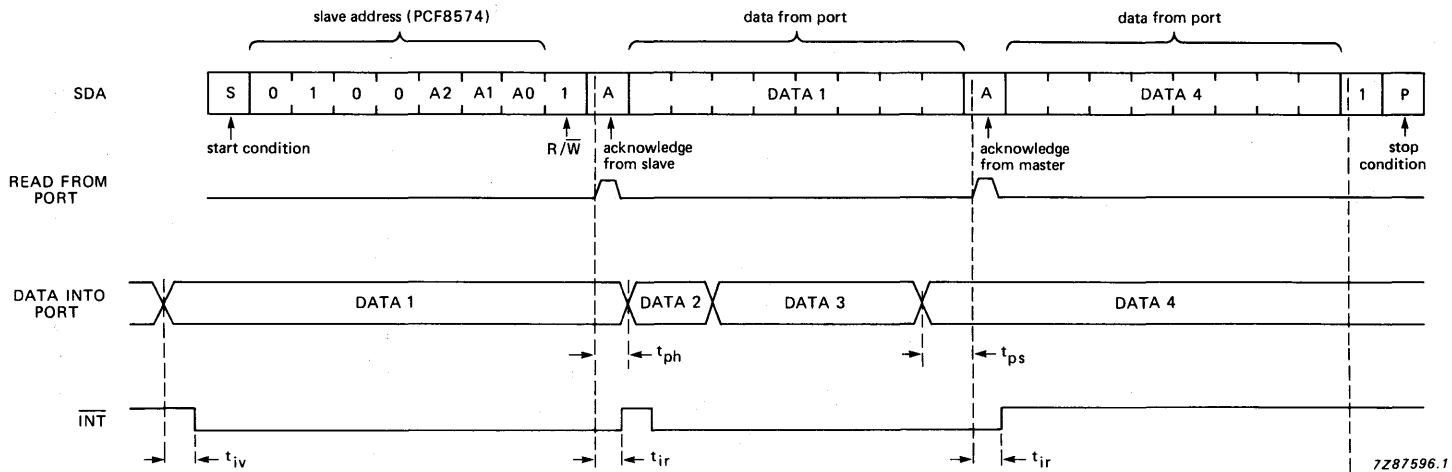

Fig.10 WRITE mode (output port).



7287596.1

Fig.11 READ mode (input port).

**Note**

A LOW-to-HIGH transition of SDA, while SCL is HIGH is defined as the stop condition (P). Transfer of data can be stopped at any moment by a stop condition. When this occurs, data present at the last acknowledge phase is valid (output mode). Input data is lost.

# Remote 8-bit I/O expander for I<sup>2</sup>C-bus

# PCF8574/PCF8574A

## Interrupt (see Figs 12 and 13)

The PCF8574/PCF8574A provides an open drain output ( $\overline{\text{INT}}$ ) which can be fed to a corresponding input of the microcomputer. This gives these chips a type of master function which can initiate an action elsewhere in the system.

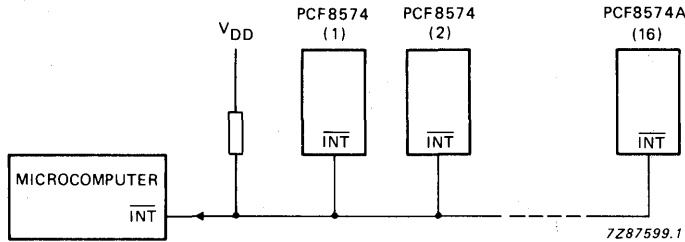

Fig.12 Application of multiple PCF8574s with interrupt.

An interrupt is generated by any rising or falling edge of the port inputs in the input mode. After time  $t_{iv}$  the signal  $\overline{\text{INT}}$  is valid.

Resetting and reactivating the interrupt circuit is achieved when data on the port is changed to the original setting or data is read from or written to the port which has generated the interrupt.

Resetting occurs as follows:

- In the READ mode at the acknowledge bit after the rising edge of the SCL signal.
- In the WRITE mode at the acknowledge bit after the HIGH-to-LOW transition of the SCL signal.

Each change of the ports after the resettings will be detected and after the next rising clock edge, will be transmitted as INT.

Reading from or writing to another device does not affect the interrupt circuit.

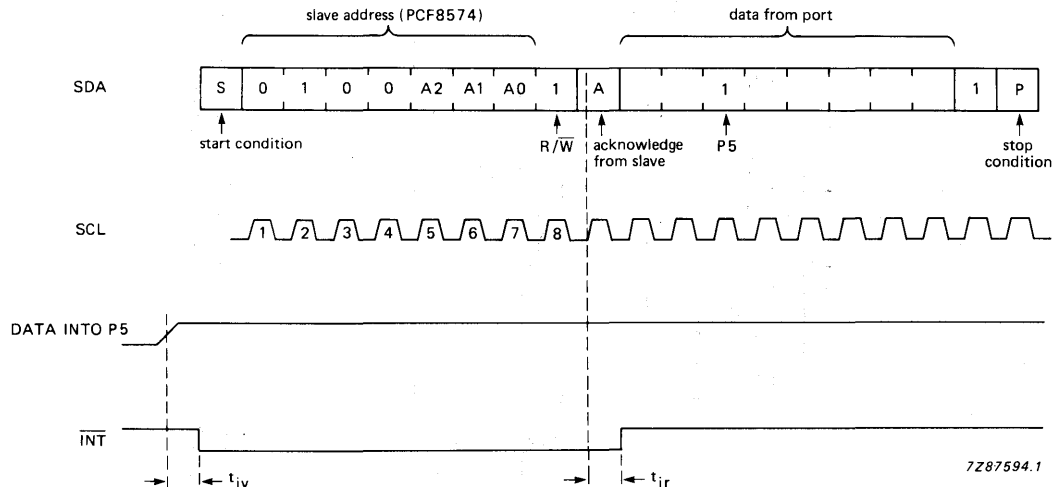

Fig.13 Interrupt generated by a change of input to port P5.



# Remote 8-bit I/O expander for I<sup>2</sup>C-bus

# PCF8574/PCF8574A

## FUNCTIONAL DESCRIPTION (continued)

### Quasi-bidirectional I/O ports (see Fig. 14)

A quasi-bidirectional port can be used as an input or output without the use of a control signal for data direction. At power-on the ports are HIGH. In this mode only a current source to V<sub>DD</sub> is active. An additional strong pull-up to V<sub>DD</sub> allows fast rising edges into heavily loaded outputs. These devices turn on when an output is written HIGH, and are switched off by the negative edge of SCL. The ports should be HIGH before being used as inputs.

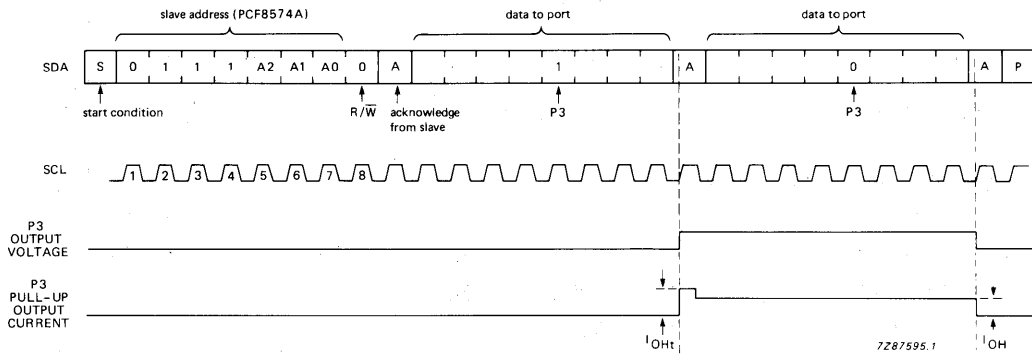

Fig. 14 Transient pull-up current I<sub>OHt</sub> while P3 changes from LOW-to-HIGH and back to LOW.

## RATINGS

Limiting values in accordance with the Absolute Maximum System (IEC 134)

parameter	symbol	min.	max.	unit
Supply voltage range	V <sub>DD</sub>	-0.5	+ 7.0	V
Input voltage range	V <sub>I</sub>	V <sub>SS</sub> - 0.5	V <sub>DD</sub> + 0.5	V
DC input current	± I <sub>I</sub>	-	20	mA
DC output current	± I <sub>O</sub>	-	25	mA
V <sub>DD</sub> or V <sub>SS</sub> current	± I <sub>DD</sub> ; ± I <sub>SS</sub>	-	100	mA
Total power dissipation	P <sub>tot</sub>	-	400	mW
Power dissipation per output	P <sub>O</sub>	-	100	mW
Operating ambient temperature range	T <sub>amb</sub>	-40	+ 85	°C
Storage temperature range	T <sub>stg</sub>	-65	+ 150	°C

## HANDLING

Inputs and outputs are protected against electrostatic discharge in normal handling. However, to be totally safe, it is desirable to take normal precautions appropriate to handling MOS devices (see 'Handling MOS Devices').

Remote 8-bit I/O expander for I<sup>2</sup>C-bus

## PCF8574/PCF8574A

## CHARACTERISTICS

$V_{DD} = 2.5$  to  $6$  V;  $V_{SS} = 0$  V;  $T_{amb} = -40$  to  $+85$  °C unless otherwise specified

parameter	conditions	symbol	min.	typ.	max.	unit
<b>Supply</b>						
Supply voltage		$V_{DD}$	2.5	—	6.0	V
Supply current	$V_{DD} = 6$ V; no load; $V_I = V_{DD}$ or $V_{SS}$					
operating	$f_{SCL} = 100$ kHz	$I_{DD}$	—	40	100	$\mu$ A
standby		$I_{DDO}$	—	2.5	10	$\mu$ A
Power-on reset level	note 1	$V_{POR}$	—	1.3	2.4	V
<b>Input SCL; input/output SDA</b>						
Input voltage LOW		$V_{IL}$	-0.5	—	$0.3V_{DD}$	V
Input voltage HIGH		$V_{IH}$	$0.7V_{DD}$	—	$V_{DD} + 0.5$	V
Output current LOW	$V_{OL} = 0.4$ V	$I_{OL}$	3	—	—	mA
Leakage current	$V_I = V_{DD}$ or $V_{SS}$	$ I_{LI} $	—	—	1	$\mu$ A
Input capacitance (SCL, SDA)	$V_I = V_{SS}$	$C_I$	—	—	7	pF
<b>I/O ports</b>						
Input voltage LOW		$V_{IL}$	-0.5	—	$0.3V_{DD}$	V
Input voltage HIGH		$V_{IH}$	$0.7V_{DD}$	—	$V_{DD} + 0.5$	V
Maximum allowed input current through protection diode	$V_I \geq V_{DD}$ or $\leq V_{SS}$	$\pm I_{IHL}$	—	—	400	$\mu$ A
Output current LOW	$V_{OL} = 1$ V; $V_{DD} = 5$ V	$I_{OL}$	10	25	—	mA
Output current HIGH	$V_{OH} = V_{SS}$	$I_{OH}$	30	—	300	$\mu$ A
Transient pull-up current HIGH during acknowledge (see Fig.14)	$V_{OH} = V_{SS}$ ; $V_{DD} = 2.5$ V	$-I_{Oht}$	—	1	—	mA
Input/Output capacitance		$C_{I/O}$	—	—	10	pF
<b>Port timing</b> (see Figs 10 and 11)						
Output data valid	$C_L = \leq 100$ pF	$t_{pv}$	—	—	4	$\mu$ s
Input data set-up		$t_{ps}$	0	—	—	$\mu$ s
Input data hold		$t_{ph}$	4	—	—	$\mu$ s

Remote 8-bit I/O expander for I<sup>2</sup>C-bus

## PCF8574/PCF8574A

parameter	conditions	symbol	min.	typ.	max.	unit
<b>Interrupt <math>\overline{INT}</math></b>						
Output current LOW	$V_{OL} = 0.4 \text{ V}$	$I_{OL}$	1.6	—	—	mA
Leakage current	$V_I = V_{DD}$ or $V_{SS}$	$ I_{L} $	—	—	1	$\mu\text{A}$
<i><math>\overline{INT}</math> timing</i> (see Figs 11 and 13)						
Input data valid	$C_L = \leq 100 \text{ pF}$	$t_{iv}$	—	—	4	$\mu\text{s}$
Reset delay		$t_{ir}$	—	—	4	$\mu\text{s}$
<b>Select inputs A0, A1, A2</b>						
Input voltage LOW		$V_{IL}$	-0.5	—	$0.3V_{DD}$	V
Input voltage HIGH		$V_{IH}$	$0.7V_{DD}$	—	$V_{DD} + 0.5$	V
Input leakage current	pin at $V_{DD}$ or $V_{SS}$	$ I_{L} $	—	—	250	nA

**Note to the characteristics**

1. The power-on reset circuit resets the I<sup>2</sup>C-bus logic with  $V_{DD} < V_{POR}$  and sets all ports to logic 1 (with current source to  $V_{DD}$ ).



Purchase of Philips' I<sup>2</sup>C components conveys a license under the Philips' I<sup>2</sup>C patent to use the components in the I<sup>2</sup>C-system provided the system conforms to the I<sup>2</sup>C specifications defined by Philips.

**I<sup>2</sup>C-bus controller****PCF8584****GENERAL DESCRIPTION**

The PCF8584 is an integrated circuit designed in CMOS technology which serves as an interface between most standard parallel-bus microcontrollers/processors and the serial I<sup>2</sup>C-bus. The PCF8584 provides both master and slave functions. Communication with the I<sup>2</sup>C-bus is carried out on a byte-wise basis using interrupt or polled handshake. It controls all the I<sup>2</sup>C-bus specific sequencing, protocol, arbitration and timing. The PCF8584 allows parallel-bus systems to communicate bidirectionally with the I<sup>2</sup>C-bus.

**Features**

- Parallel-bus/I<sup>2</sup>C-bus protocol converter
- Compatible with most parallel-bus processors including MAB8049, MAB8051, SCN68000 and Z80
- Automatic selection of bus interface
- Programmable interrupt vector
- Multi-master capability
- I<sup>2</sup>C-bus monitor mode
- Long-distance mode
- Operating supply voltage 4.5 to 5.5 V
- Operating temperature range -40 to +85 °C

**PACKAGE OUTLINES**

PCF8584P: 20-lead DIL; plastic (SOT146).

PCF8584T: 20-lead mini-pack; plastic (SO20; SOT163A).

I<sup>2</sup>C-bus controller

PCF8584

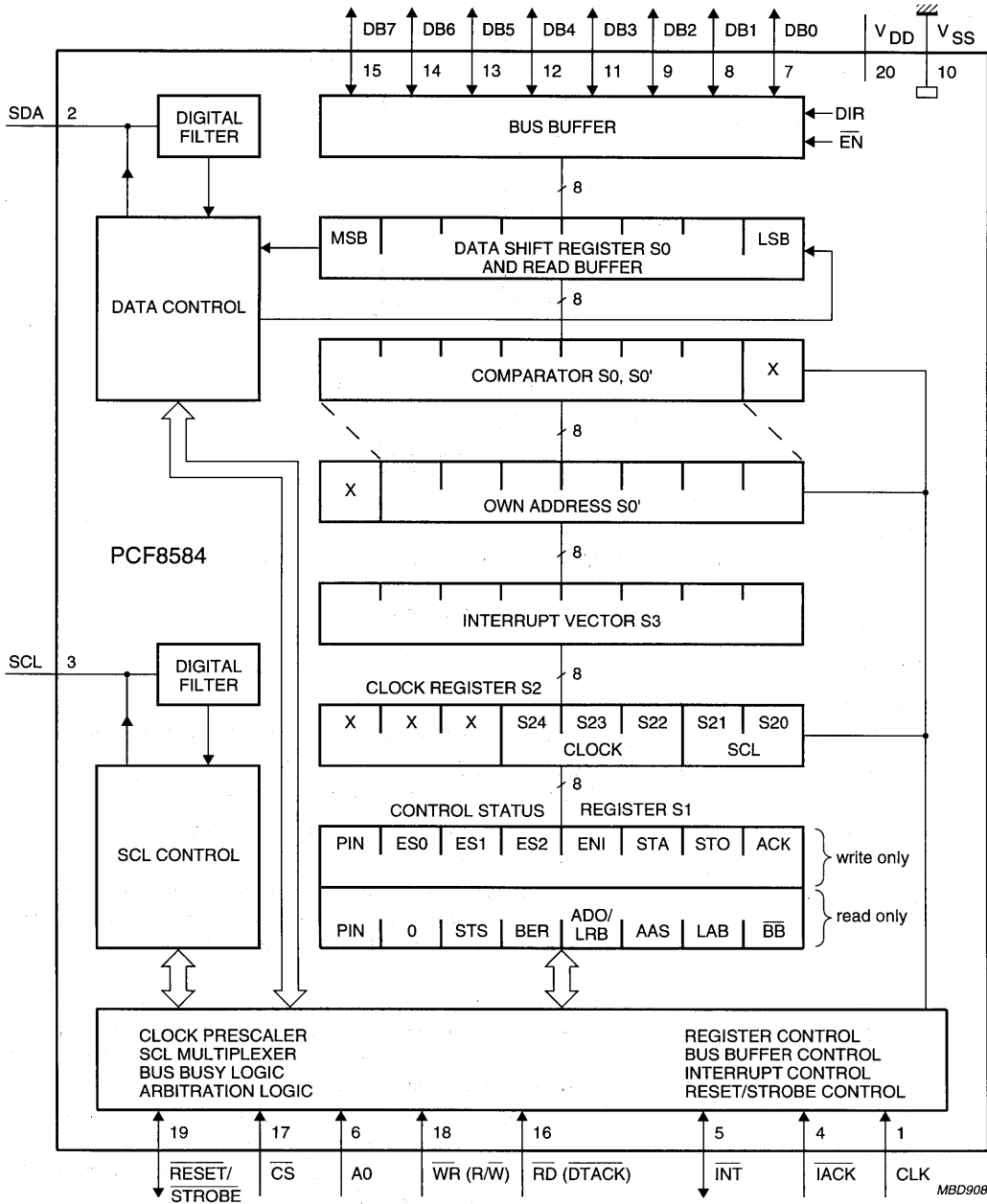

Where:

( ) indicate the SCN68000 pin name designations.

X = don't care.

Fig.1 Block diagram.

I<sup>2</sup>C-bus controller

PCF8584

## PINNING

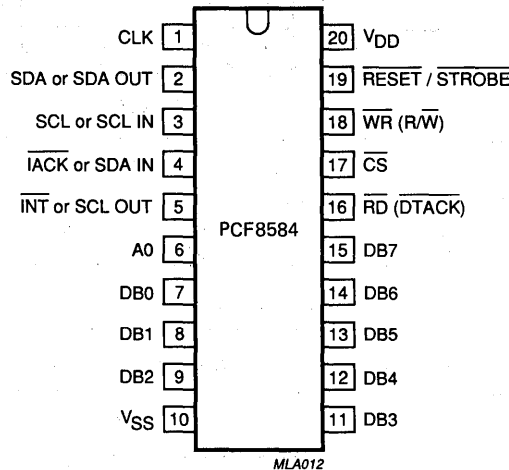

## Where:

( ) indicate the SCN68000 pin name designations.

Fig.2 Pinning diagram.

## Pin functions

pin	mnemonic	function	description
1	CLK	I	Clock input from microprocessor clock generator (internal pull-up).
2	SDA or SDA OUT	I/O	I <sup>2</sup> C-bus serial data input/output (open-drain). Serial data output in long-distance mode.
3	SCL or SCL IN	I/O	I <sup>2</sup> C-bus serial clock input/output (open-drain). Serial clock input in long-distance mode.
4	IACK or SDA IN	I	Interrupt acknowledge input (internal pull-up); when this signal is asserted the interrupt vector in Register S2 will be available at the bus port if the ENI flag is set. Serial data input in long-distance mode.
5	INT or SCL OUT	O	Interrupt output (open-drain); this signal is enabled by the ENI flag in Register S1. It is asserted, when the PIN flag is reset. (PIN is reset after one byte is transmitted or received over the I <sup>2</sup> C-bus). Serial clock output in long-distance mode.
6	A0	I	Register select input (internal pull-up); this input selects between the control/status register and the other registers. Logic 1 selects Register S1, logic 0 selects one of the other registers depending on bits loaded in ES0, ES1 and ES2 of Register S1.
7	DB0	I/O	Bidirectional 8-bit bus port.
8	DB1	I/O	
9	DB2	I/O	
10	VSS		Negative supply voltage.

I<sup>2</sup>C-bus controller

PCF8584

## Pin functions (continued)

pin	mnemonic	function	description
11	DB3	I/O	
12	DB4	I/O	
13	DB5	I/O	Bidirectional 8-bit bus port.
14	DB6	I/O	
15	DB7	I/O	
16	$\overline{RD}$ ( $\overline{DTACK}$ )	I (O)	$\overline{RD}$ is the read control input for MAB8049, MAB8051 or Z80-type processors. $\overline{DTACK}$ is the data transfer control output for 68000-type processors (open-drain).
17	$\overline{CS}$	I	Chip select input (internal pull-up).
18	$\overline{WR}$ (R/ $\overline{W}$ )	I	$\overline{WR}$ is the write control input for MAB8048, MAB8051 or Z80-type processors (internal pull-up). R/ $\overline{W}$ control input for 68000-type processors.
19	$\overline{RESET}/$ $\overline{STROBE}$	I/O	Reset input (open-drain); this input forces the I <sup>2</sup> C-bus controller into a predefined state; all flags are reset, except PIN, which is set. Also functions as strobe output.
20	V <sub>DD</sub>		Positive supply voltage.

I<sup>2</sup>C-bus controller

PCF8584

## FUNCTIONAL DESCRIPTION

## General

The PCF8584 acts as an interface device between standard high-speed parallel buses and the serial I<sup>2</sup>C-bus. On the I<sup>2</sup>C-bus, it can act either as master or slave. Bidirectional data transfer between the I<sup>2</sup>C-bus and the parallel-bus microprocessor is carried out on a byte-wise basis, using either an interrupt or polled handshake. Interface to either 80XX-type (e.g. MAB8048, MAB8051, Z80) or 68000-type buses is possible. Selection of bus type is automatically performed (see **Interface mode control**).

**Table 1** Control signals utilized by the PCF8584 for processor interfacing

type	R/ $\overline{W}$	$\overline{WR}$	$\overline{RD}$	$\overline{DTACK}$	$\overline{IACK}$
MAB8049/51	NO	YES	YES	NO	NO
SCC68000	YES	NO	NO	YES	YES
Z80	NO	YES	YES	NO	YES

The structure of the PCF8584 is similar to that of the I<sup>2</sup>C-bus interface section of the MAB8400-series of microcontrollers, but with a modified control structure. The PCF8584 has five internal register locations. Three of these (Own Address register S0', Clock register S2 and Interrupt Vector S3) are used for initialization of the PCF8584. Normally they are only written once directly after resetting of the PCF8584. The remaining two registers function as double registers (Data Buffer/Shift register S0, and Control/Status register S1) which are used during actual data transmission/reception. By using these double registers, which are separately write and read accessible, overhead for register access is reduced. S0 is a combination of a shift register and data buffer. S0 performs all serial-to-parallel interfacing with the I<sup>2</sup>C-bus. S1 contains I<sup>2</sup>C-bus status information required for bus access and/or monitoring.

## Interface mode control (IMC)

Selection of either an 80XX-mode or 68000-mode interface is achieved by detection of the  $\overline{WR}$  -  $\overline{CS}$  signal sequence. The concept takes advantage of the fact that the write control input is common for both types of interfaces. The chip is non-initialized after reset until register S0' is accessed. An 80XX-type interface is default. If a HIGH-to-LOW transition of  $\overline{WR}$  (R/ $\overline{W}$ ) is detected while  $\overline{CS}$  is HIGH, the 68000-type interface mode is selected and the  $\overline{DTACK}$  output is enabled.

## Note:

The very first access to the PCF8584 after a reset must be a write access to register S0' in order to set the appropriate interface mode.



I<sup>2</sup>C-bus controller

PCF8584

**FUNCTIONAL DESCRIPTION** (continued)**Set-up Registers S0', S2 and S3***Own Address Register S0'*

When addressed as a slave, this register is loaded with the 7-bit I<sup>2</sup>C-bus address to which the PCF8584 is to respond. The "Addressed As Slave" (AAS) bit in Status register S1 is set when this address is received. Programming of this register is accomplished via the parallel-bus when A0 is LOW, with the appropriate bit combinations set in Control Status register S1 (S1 is written when A0 is HIGH). Bit combinations for accessing all registers are given in Tables 4 and 5. After reset S0' has default address '00' Hex.

*Clock Register S2*

Register S2 provides control over chip clock frequency and SCL clock frequency. S20 and S21 provide a selection of 4 different I<sup>2</sup>C-bus SCL frequencies which are shown in Table 2.

**Table 2** Register S2 selection of SCL frequency

bit		SCL approximate frequency (kHz)
S21	S20	
0	0	90
0	1	45
1	0	11
1	1	1.5

S22, S23 and S24 are used for control of the internal clock prescaler. Due to the possibility of varying microprocessor clock signals, the prescaler can be programmed to adapt to 5 different clock rates, thus providing a constant internal clock. This is required to provide a stable time base for the SCL generator and the digital filters associated with the I<sup>2</sup>C-bus signals SCL and SDA. Selection for adaptation to external clock rates is shown in Table 3. After reset, a clock frequency of 12 MHz is the default value.

**Table 3** Register S2 selection of clock frequency

S24	bit		clock frequency (MHz)
	S23	S22	
0	X	X	3
1	0	0	4.43
1	0	1	6
1	1	0	8
1	1	1	12

**Where:** X = don't care.

## I<sup>2</sup>C-bus controller

PCF8584

### *Interrupt Vector S3*

The interrupt vector register provides an 8-bit user-programmable vector for vectored-interrupt micro-processors. The vector is sent to the bus port when an interrupt acknowledge signal is asserted and the ENI (enable interrupt) flag is set. Default vector values are as follows:

- Vector is '00' Hex in 80XX-mode
- Vector is '0F' Hex in 68000-mode

On reset the PCF8584 is in the 80XX mode, thus the default interrupt vector becomes '00' Hex.

### **Interface Registers S0 and S1**

#### *Data Shift Register S0*

S0 acts as serial shift register interfacing to the I<sup>2</sup>C-bus. S0 is a combination of a shift register and a data buffer; parallel data is always written to the shift register and read from the data buffer. Serial data is shifted in/out the shift register, and in receiver mode the data from the shift register is copied to the data buffer during the acknowledge phase (see also PIN bit). All read and write operations to the I<sup>2</sup>C-bus are done via this register.

#### *Control/Status Register S1*

Register S1 is accessed by a HIGH signal on register select input A0. To facilitate communication between the microcontroller/processor and the I<sup>2</sup>C-bus, register S1 has separate read and write functions for all bit positions.

The write-only section has been split into 2 parts:

- The ESO (Enable Serial Output) enables or disables the serial output. When ESO is LOW, register access for initialization is possible. When ESO is HIGH, serial communication is enabled; communication with serial shift register S0 is enabled and the S1 bus status bits are made available for reading. Select control bits ES1 and ES2 control selection of other registers for initialization and control of normal operation. After these bits are programmed for access to the desired register (see Tables 4 and 5), the register is selected by a logic LOW level on register select pin A0.

#### **Note:**

With ESO = 0, bits ENI, STA, STO and ACK of S1 can be read for test purposes.

I<sup>2</sup>C-bus controller

PCF8584

**FUNCTIONAL DESCRIPTION** (continued)*Control/Status Register S1* (continued)**Table 4** Register access control; ESO = logic 0 (serial interface off)

A0	ES1	ES1	$\overline{\text{ACK}}$	operation
H	X	X	X	READ/WRITE CONTROL REGISTER (S1) STATUS (S1) not available
L	0	0	X	READ/WRITE OWN ADDRESS (S0')
L	0	1	X	READ/WRITE INTERRUPT VECTOR (S3)
L	1	0	X	READ/WRITE CLOCK REGISTER (S2)

**Table 5** Register access control; ESO = logic 1 (serial interface on)

A0	ES1	ES2	$\overline{\text{ACK}}$	operation
H	X	X	H	WRITE CONTROL REGISTER (S1)
H	X	X	H	READ STATUS REGISTER (S1)
L	X	0	H	READ/WRITE DATA (S0)
L	X	1	H	READ/WRITE INTERRUPT VECTOR (S3)
X	0	X	L	READ INTERRUPT VECTOR (acknowledge cycle)
X	1	X	L	long-distance mode

Instruction control bits ENI, STA, STO and ACK are used in normal operation to enable the interrupt output ( $\overline{\text{INT}}$ ), generate I<sup>2</sup>C-bus START and STOP conditions, and program the acknowledge response, respectively. These possibilities are shown in Table 6.

I<sup>2</sup>C-bus controller

PCF8584

**Table 6** Instruction table for serial bus control

STA	STO	present mode	function	operation
1	0	SLV/REC	START	transmit START + address remain MST/TRM if R/ $\bar{W}$ = logic 0; go to MST/REC if R/ $\bar{W}$ = logic 1
1	0	MST/TRM	REPEAT START	same as for SLV/REC
0	1	MST/REC MST/TRM	STOP READ STOP WRITE	transmit stop go to SLV/REC mode (see note 1)
1	1	MST	DATA CHAINING	send STOP, START and address after last master frame without STOP sent (see note 2)
0	0	ANY	NOP	no operation (see note 3)

**Notes to Table 6**

1. In master-receiver mode, the last byte must be terminated with ACK bit HIGH ("negative-acknowledge"; see I<sup>2</sup>C-bus specification).
2. If both STA and STO are set HIGH simultaneously in master mode, a STOP condition followed by a START condition + address will be generated. This allows "chaining" of transmissions without relinquishing bus control.
3. All other STA, STO mode combinations not mentioned in Table 6 are NOPs.

The instruction bits are defined as follows:

- STA, STO: These bits control the generation of the I<sup>2</sup>C-bus START condition + transmission of slave address and R/ $\bar{W}$  bit, generation of repeated START condition, and generation of the STOP condition.
- ENI: This bit enables the external interrupt output  $\overline{INT}$ , which is generated when the PIN bit is reset.
- ACK: This bit must be set normally to a '1'. This causes the I<sup>2</sup>C-bus controller to send an acknowledge automatically after each byte (this occurs during the ninth clock pulse). The bit must be reset when the I<sup>2</sup>C-bus controller is operating in master/receiver mode, and requires no further data to be sent from the slave transmitter. This causes a negative acknowledge on the I<sup>2</sup>C-bus, which halts further transmission from the slave device.

## I<sup>2</sup>C-bus controller

PCF8584

### FUNCTIONAL DESCRIPTION (continued)

#### I<sup>2</sup>C-bus status information

The read-only section consists of I<sup>2</sup>C-bus status information. The functions are as follows:

- STS: When in slave-receiver mode, this flag is asserted when an externally generated STOP condition is detected (only used in slave-receiver mode).
- BER: Bus error. A misplaced START or STOP condition has been detected.
- LRB/AD0: Last Received Bit/Address 0 "General Call" Bit. This dual function status bit holds the value of the last received bit over the I<sup>2</sup>C-bus when AAS = 0. Normally this will be the value of the slave acknowledge; thus checking for slave acknowledgment is done via testing of the LRB bit. When AAS = 1 ("Address As Slave"), the I<sup>2</sup>C-bus controller has been addressed as a slave and this bit will be set if the slave address received was the "general call" address, or if it was the I<sup>2</sup>C-bus controller's slave address.
- AAS: "Addressed As Slave" bit. When acting as slave-receiver, this flag is set when an incoming address over the I<sup>2</sup>C-bus matches the value in Own Address register S0', or if the I<sup>2</sup>C-bus "general call" address ("00" Hex) has been received.
- LAB: "Lost Arbitration" bit. This bit is set when, in multmaster operation, arbitration is lost to another master on the I<sup>2</sup>C-bus.
- $\overline{BB}$ : "Bus Busy" bit. This is read-only flag indicating when the I<sup>2</sup>C-bus is in use. A zero indicated that the bus is busy, and access is not possible. This bit is set/reset by STOP/START conditions.

#### PIN bit

The PIN bit "Pending Interrupt Not" is a read-only flag which is used to synchronize serial communication. Each time a serial data transmission is initiated (by setting the STA bit in the same register), the PIN will be set automatically. After successful transmission of one byte (9 clock pulses, including acknowledge), this bit will be automatically reset indicating a complete byte transmission. When the ENI bit is also set, the PIN flag triggers an external interrupt via the  $\overline{INT}$  output when PIN is reset. When in receiver mode, the PIN bit is also reset on completion of each received byte. In polled applications, the PIN bit is tested to determine when a serial transmission has been completed. During register transfers the I<sup>2</sup>C-bus controller Data Register S0 and its internal shift register (not accessible directly), the I<sup>2</sup>C-bus controller will delay serial transmission by holding the SCL line LOW until the PIN bit becomes set. In receiver mode, the PIN bit is automatically set when the data register S0 is read. When the PIN bit becomes set all status bits will be reset, with exception of  $\overline{BB}$ .

## I<sup>2</sup>C-bus controller

PCF8584

### Multi-master operations

To avoid conflict between data and repeated START and STOP operations, multi-master systems have some limitations:

- Transmissions requiring a repeated START condition must have identical format among all potential masters for both read and write operations
- For correct arbitration masters may only attempt to send data simultaneously to the same location, if they use the same formats (i.e. number of data bytes, location of the repeated START, etc.). If this condition is designed not to occur, differing formats may be used.

**Reset** A low-level pulse on the  $\overline{\text{RESET}}$  input forces the I<sup>2</sup>C-bus controller into a well-defined state. All flags are reset (zero state), except the PIN flag, which is set. The  $\overline{\text{RESET}}$  pin is also used for the  $\overline{\text{STROBE}}$  output signal. Both functions are separated on-chip by a digital filter. The reset input signal has to be sufficiently long (minimum 30 clock cycles) to pass through the filter. The  $\overline{\text{STROBE}}$  output signal is sufficiently short (8 clock cycles) to be blocked by the filter. For more detailed information on the Strobe function see **Special function modes**.

### Comparison to the MAB8400 I<sup>2</sup>C-bus interface

The structure of the PCF8584 is similar to that of the MAB8400 series of microcontrollers, but with a modified control structure. Access to all I<sup>2</sup>C-bus control and status registers is done via the parallel-bus port in conjunction with register select input A0, and control bits ESO, ES1 and ES2. The main differences are highlighted below.

#### *Deleted functions*

The following functions are not available in the PCF8584:

- Always selected (ALS flag)
- Access to the bit counter (BC0 to BC2)
- Full SCL frequency selection (2 bits instead of 5 bits)
- The non-acknowledge mode (ACK flag)
- Asymmetrical clock (ASC flag)

#### *Added functions*

The following functions either replace the deleted functions or are completely new:

- Chip clock prescaler
- Assert acknowledge bit (ACK flag)
- Register selection bits (ES1 and ES2 flags)
- Additional status flags
- Automatic interface control between 80XX and 68000-type microprocessors
- Programmable interrupt vector
- Strobe generator
- Bus monitor function
- Long-distance mode (non-I<sup>2</sup>C-bus mode; only for communication between remote parallel-bus processors)

## I<sup>2</sup>C-bus controller

PCF8584

### Special function modes

#### *Strobe*

When the I<sup>2</sup>C-bus controller receives its own address (or the "00" Hex general call address) followed immediately by a STOP condition (i.e. no further data transmitted after the address), a strobe output signal is generated at the  $\overline{\text{RESET}}/\text{STROBE}$  pin (pin 19). The  $\overline{\text{STROBE}}$  signal consists of a monostable output pulse (active LOW), eight clock cycles long (see Fig.10). It is generated after the STOP condition is received, preceded by the correct slave address. This output can be used as a bus access controller for multi-master parallel-bus systems (see Fig.14).

#### *Long-distance mode*

The long-distance mode provides a serial communication link between parallel processors using two or more I<sup>2</sup>C-bus controllers. This mode is selected by setting ES1 to logic 1 while the serial interface is enabled (ESO = 1). In this mode the I<sup>2</sup>C-bus protocol is transmitted over 4 unidirectional lines, SDA, OUT, SCL IN, SDA IN and SCL OUT (pins 2, 3, 4 and 5). These communication lines should be connected to the line drivers/receivers for long distance applications. Specification for long distance transmission is then given by the chosen standard. Control of bus frequency, data transmission etc. is the same as in normal I<sup>2</sup>C-bus mode. After reading or writing data to shift register SO, long-distance mode must be initialized by setting ESO and ES1 to logic 1. Because the interrupt output  $\overline{\text{INT}}$  is not available in this operating mode, data reception must be polled.

#### *Monitor mode*

When the 7-bit Own Address register SO' is loaded with all zeros, the I<sup>2</sup>C-bus controller acts as a passive I<sup>2</sup>C monitor. The main features of the monitor mode are as follows:

- The controller is always selected
- The controller is always in the slave-receiver mode
- The controller never generates an acknowledge
- The controller never generates an interrupt request
- A pending interrupt condition does not force SCL LOW
- Received data is automatically transferred to the read buffer
- Bus traffic is monitored by the PIN bit, which is reset after the acknowledge bit has been transmitted and is set as soon as the first bit of the next byte is detected

**I<sup>2</sup>C-bus controller****PCF8584****RATINGS**

Limiting values in accordance with the Absolute Maximum System (IEC 134)

parameter	symbol	min.	max.	unit
Supply voltage range (pin 20)	V <sub>DD</sub>	-0.3	+ 7.0	V
Voltage range on any input*	V <sub>I</sub>	-0.8	V <sub>DD</sub> + 0.5	V
DC input current (any input)	± I <sub>I</sub>	-	10	mA
DC output current (any output)	± I <sub>O</sub>	-	10	mA
Total power dissipation	P <sub>tot</sub>	-	300	mW
Power dissipation per output	P <sub>O</sub>	-	50	mW
Operating ambient temperature range	T <sub>amb</sub>	-40	+ 85	°C
Storage temperature range	T <sub>stg</sub>	-65	+ 150	°C

\* Measured via a 500 Ω resistor.

**Note to the Ratings**

Stresses above those listed in accordance with Absolute Maximum System may cause permanent damage to the device. This is a stress rating only, and functional operation of the device at these or any other conditions above those indicated in the operational sections of this specification is not implied. Exposure to absolute maximum rating condition for extended periods may affect reliability.

**HANDLING**

Inputs and outputs are protected against electrostatic discharge in normal handling. However, to be totally safe, it is good practice to take normal precautions appropriate to handling MOS devices (see 'Handling MOS Devices').



I<sup>2</sup>C-bus controller

PCF8584

## CHARACTERISTICS

 $V_{DD} = 5 \pm 10\%$ ;  $V_{SS} = 0\text{ V}$ ;  $T_{amb} = -40\text{ to }+85\text{ }^{\circ}\text{C}$ ; unless otherwise specified

parameter	conditions	symbol	min.	typ.	max.	unit
<b>Supply</b>						
Supply voltage range		$V_{DD}$	4.5	5.0	5.5	V
Supply current standby	note 1	$I_{DD1}$	—	—	2.5	$\mu\text{A}$
operating	note 2	$I_{DD2}$	—	—	1.5	mA
<b>Inputs</b>						
SCL, SDA						
Input voltage LOW	note 3	$V_{IL1}$	0	—	0.8	V
Input voltage HIGH	note 3	$V_{IH1}$	2.0	—	$V_{DD}$	V
Input voltage LOW	note 4	$V_{IL2}$	0	—	$0.3V_{DD}$	V
Input voltage HIGH	note 4	$V_{IH2}$	$0.7V_{DD}$	—	$V_{DD}$	V
Resistance to $V_{DD}$	$T_{amb} = 25\text{ }^{\circ}\text{C}$ ; note 5	$R_i$	25	—	100	$\text{k}\Omega$
<b>Outputs</b>						
Output current LOW	$V_{OL} = 0.4\text{ V}$	$I_{OL}$	3.0	—	—	mA
Output current HIGH	$V_{OH} = 2.4\text{ V}$ ; note 6	$-I_{OH}$	2.4	—	—	mA
Leakage current	note 7	$\pm I_{LO}$	—	—	1	$\mu\text{A}$

## Notes to the characteristics

- 22  $\text{k}\Omega$  pull-ups on D0 to D7; 10  $\text{k}\Omega$  pull-ups on SDA, SCL,  $\overline{\text{RD}}$ ;  $\overline{\text{RESET}}$  tied to  $V_{SS}$ ; remaining pins open-circuit.
- Same as note 1, but CLK waveform with 50% duty factor at 12 MHz.
- CLK,  $\overline{\text{ACK}}$ , A0,  $\overline{\text{CS}}$ ,  $\overline{\text{WR}}$ ,  $\overline{\text{RD}}$ ,  $\overline{\text{RESET}}$ , TTL level inputs.
- SDA, SCL, D0 to D7, CMOS level inputs.
- CLK,  $\overline{\text{ACK}}$ , A0,  $\overline{\text{CS}}$ ,  $\overline{\text{WR}}$ .
- D0 to D7.
- D0 to D7 3-state, SDA, SCL,  $\overline{\text{INT}}$ ,  $\overline{\text{RD}}$ ,  $\overline{\text{RESET}}$ .

I<sup>2</sup>C-bus controller

PCF8584

**Timing specifications**

All the timing values are valid within the operating supply voltage and ambient temperature range and refer to  $V_{IL}$  and  $V_{IH}$  with an input voltage swing of  $V_{SS}$  to  $V_{DD}$ .

parameter	symbol	min.	typ.	max.	unit
<b>I<sup>2</sup>C-bus timing</b>					
SCL clock frequency	f <sub>SCL</sub>	—	—	100	kHz
Tolerable bus spike width	t <sub>SW</sub>	—	—	100	ns
Bus free time	t <sub>BUF</sub>	4.7	—	—	μs
Start condition set-up time	t <sub>SU; STA</sub>	4.7	—	—	μs
Start condition hold time	t <sub>HD; STA</sub>	4.0	—	—	μs
SCL LOW time	t <sub>LOW</sub>	4.7	—	—	μs
SCL HIGH time	t <sub>HIGH</sub>	4.0	—	—	μs
SCL and SDA rise time	t <sub>r</sub>	—	—	1.0	μs
SCL and SDA fall time	t <sub>f</sub>	—	—	0.3	μs
Data set-up time	t <sub>SU; DAT</sub>	250	—	—	ns
Data hold time	t <sub>HD; DAT</sub>	0	—	—	ns
SCL LOW to data out valid	t <sub>VD; DAT</sub>	—	—	3.4	μs
Stop condition set-up time	t <sub>SU; STO</sub>	4.0	—	—	μs

I<sup>2</sup>C-bus controller

PCF8584

**Parallel interface timing** (see Figs 3 to 10)

All the timing limits are valid within the operating supply voltage and ambient temperature range and refer to  $V_{IL}$  and  $V_{IH}$  with an input voltage swing of  $V_{SS}$  to  $V_{DD}$ .

$C_L = 100$  pF,  $R_L = 1.5$  k $\Omega$  (connected to  $V_{DD}$ ) for open-drain and high-impedance outputs, where applicable (for measurement purposes only).

parameter	figure	symbol	min.	typ.	max.	unit
Clock rise time	3	$t_r$	—	—	6	ns
Clock fall time	3	$t_f$	—	—	6	ns
Input clock period (50% duty factor)	3	$t_{CLK}$	83	—	333	ns
$\overline{CS}$ set-up to $\overline{RD}$ , $\overline{WR}$ LOW	4	$t_{SU1}$	30	—	—	ns
$\overline{CS}$ hold from $\overline{RD}$ , $\overline{WR}$ HIGH	4	$t_{HD1}$	0	—	—	ns
A0 set-up to $\overline{RD}$ , $\overline{WR}$ LOW	4	$t_{SU2}$	10	—	—	ns
A0 hold from $\overline{RD}$ , $\overline{WR}$ HIGH	4	$t_{HD2}$	20	—	—	ns
$\overline{WR}$ pulse width	4	$t_{W1}$	230	—	—	ns
$\overline{RD}$ pulse width	4	$t_{W2}$	230	—	—	ns
Data set-up before $\overline{WR}$ HIGH	4	$t_{SU3}$	150	—	—	ns
Data valid after $\overline{RD}$ LOW	4	$t_{VD}$	—	110	180	ns
Data hold after $\overline{WR}$ HIGH	4	$t_{HD3}$	30	—	—	ns
Data bus floating after $\overline{RD}$ HIGH	4	$t_{FL}$	70	—	—	ns
A0 set-up to $\overline{CS}$ LOW	5 and 6	$t_{SU4}$	30	—	—	ns
$R/\overline{WR}$ set-up to $\overline{CS}$ LOW	5 and 6	$t_{SU5}$	30	—	—	ns
Data valid after $\overline{CS}$ LOW	5	$t_{VD1}$	—	110	180	ns
$\overline{DTACK}$ LOW after $\overline{CS}$ LOW	5 and 6	$t_{d1}$	—	$3t_{CLK} + 75$	$3t_{CLK} + 150$	ns
A0 hold from $\overline{CS}$ HIGH	5 and 6	$t_{HD4}$	0	—	—	ns
$R/\overline{WR}$ hold from $\overline{CS}$ HIGH	5 and 6	$t_{HD5}$	0	—	—	ns
Data hold after $\overline{CS}$ HIGH	5	$t_{HD6}$	160	—	—	ns
$\overline{DTACK}$ HIGH from $\overline{CS}$ HIGH	5 and 6	$t_{d2}$	—	100	120	ns
Data hold after $\overline{CS}$ HIGH	6	$t_{HD7}$	0	—	—	ns
Data set-up to $\overline{CS}$ LOW	6	$t_{SU6}$	0	—	—	ns
$\overline{INT}$ HIGH from $\overline{IACK}$ LOW	7 and 8	$t_{d3}$	—	130	180	ns
Data valid after $\overline{IACK}$ LOW	7 and 8	$t_{VD2}$	—	140	190	ns

I<sup>2</sup>C-bus controller

PCF8584

## Parallel interface timing (continued)

parameter	figure	symbol	min.	typ.	max.	unit
$\overline{\text{TACK}}$ pulse width	7 and 8	$t_{W3}$	230	—	—	ns
Data hold after $\overline{\text{TACK}}$ HIGH	7 and 8	$t_{HD8}$	100	—	—	ns
$\overline{\text{DTACK}}$ LOW from $\overline{\text{TACK}}$ LOW	8	$t_{d4}$	—	$3t_{\text{CLK}} + 75$	$3t_{\text{CLK}} + 150$	ns
$\overline{\text{DTACK}}$ HIGH from $\overline{\text{TACK}}$ HIGH	8	$t_{d5}$	—	120	140	ns
Reset pulse width	9	$t_{W4}$	$30t_{\text{CLK}}$	—	—	ns
Strobe pulse width	10	$t_{W5}$	$8t_{\text{CLK}}$	$8t_{\text{CLK}} + 90$	—	ns

## Notes to parallel interface timing

1. A minimum of 6 clock cycles must elapse between consecutive parallel-bus accesses when the I<sup>2</sup>C-bus controller operates at 8 or 12 MHz. This may be reduced to 3 clock cycles for lower operating frequencies.
2. After reset the chip clock default is 12 MHz.

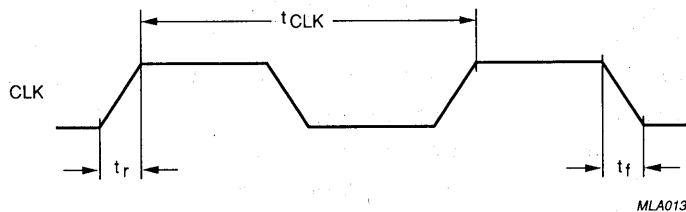

MLA013

Fig.3 Clock input timing.

I<sup>2</sup>C-bus controller

PCF8584

Timing diagrams

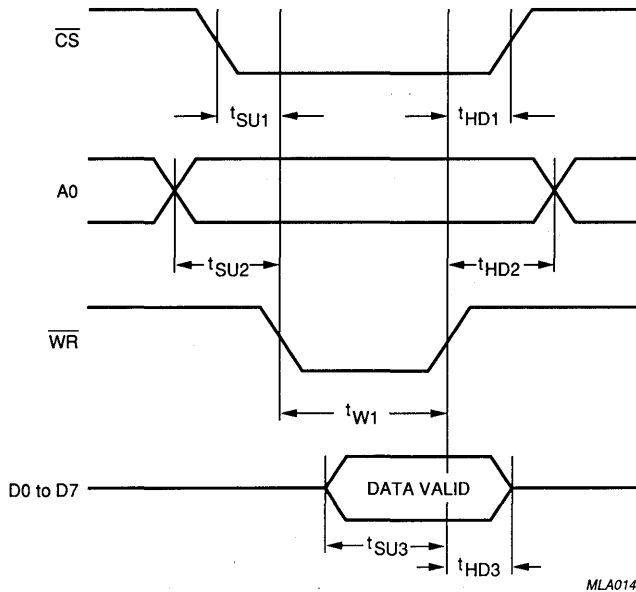

(a)

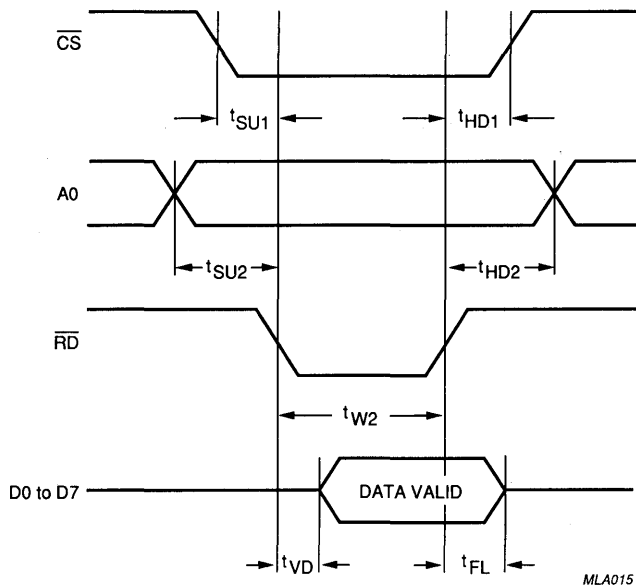

(b)

Fig. 4 Bus timing (80XX-mode); (a) write cycle, (b) read cycle.

I<sup>2</sup>C-bus controller

PCF8584

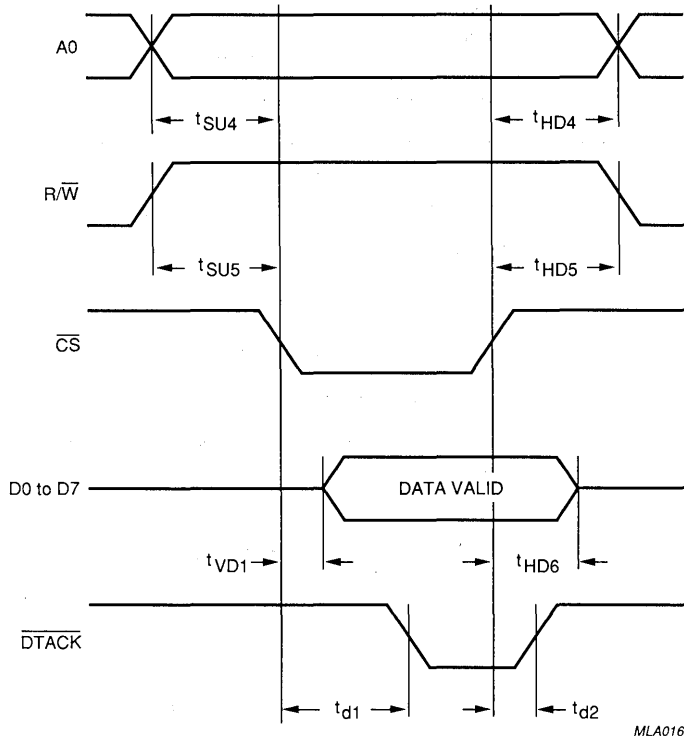

Fig.5 Bus timing; 68000-mode read cycle.

I<sup>2</sup>C-bus controller

PCF8584

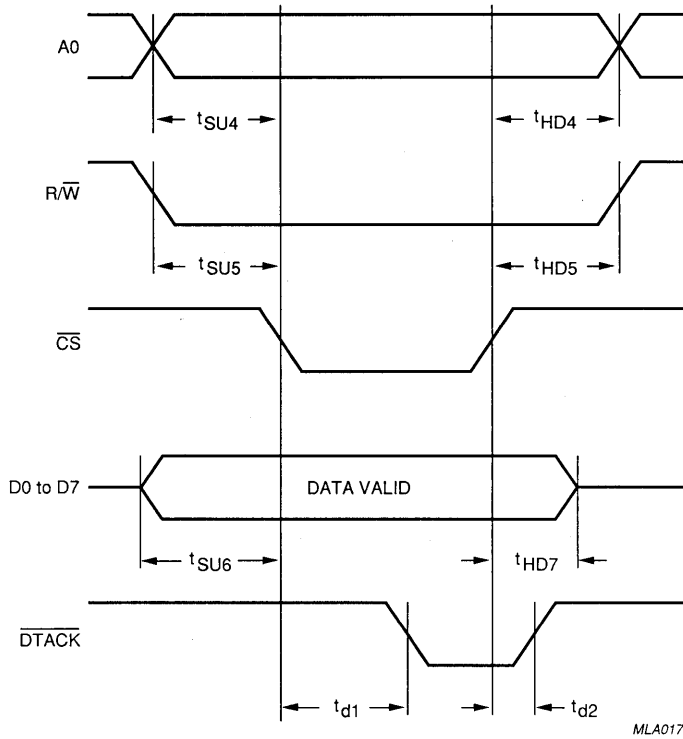

Fig.6 Bus timing; 68000-mode write cycle.

I<sup>2</sup>C-bus controller

PCF8584

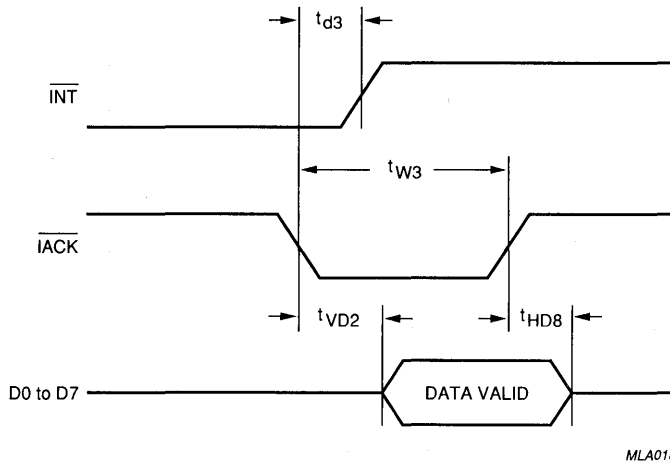

Fig.7 Interrupt timing; 80XX-mode.

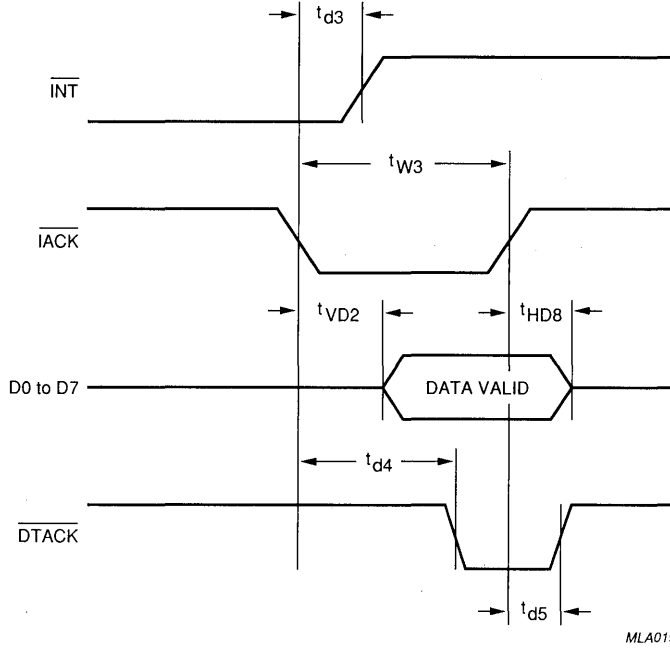

Fig.8 Interrupt timing; 68000-mode.



I<sup>2</sup>C-bus controller

PCF8584

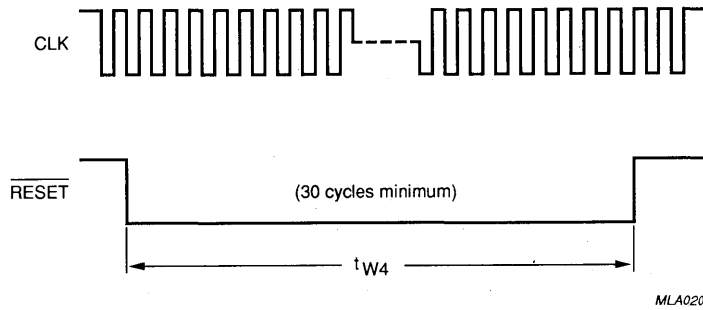

Fig.9 Reset timing.

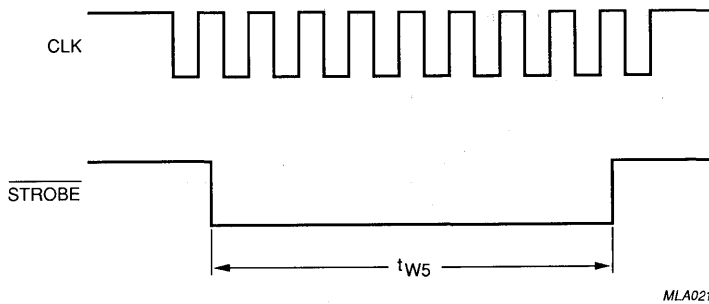
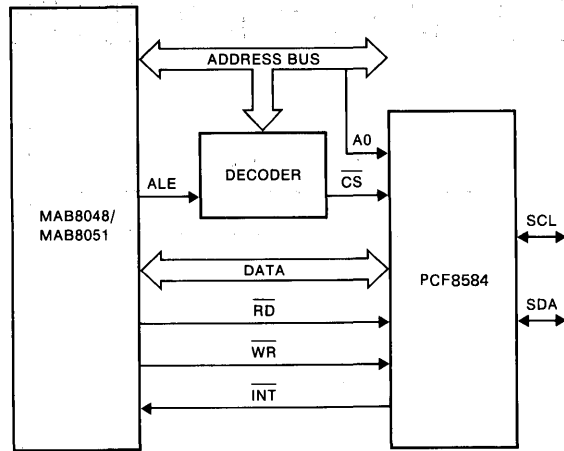

Fig.10 Strobe timing.

APPLICATION INFORMATION



7Z28116

Fig.11 Application diagram using the MAB8048/MAB8051.

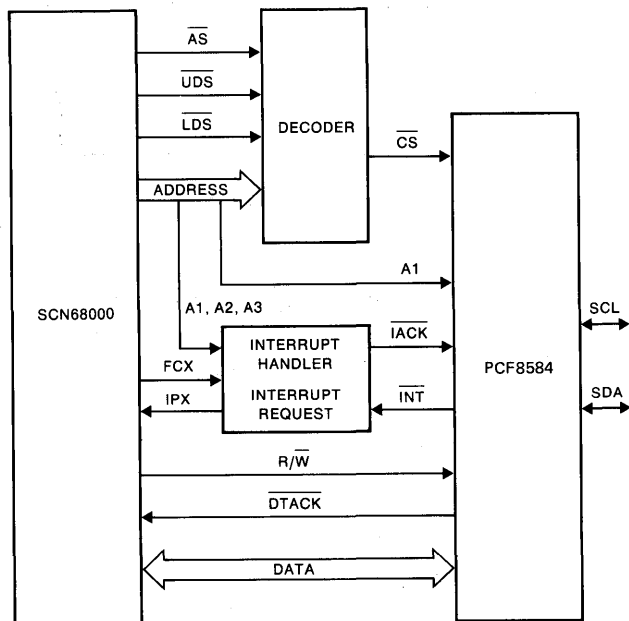

7Z28117

Fig.12 Application diagram using the SCN68000.

I<sup>2</sup>C-bus controller

PCF8584

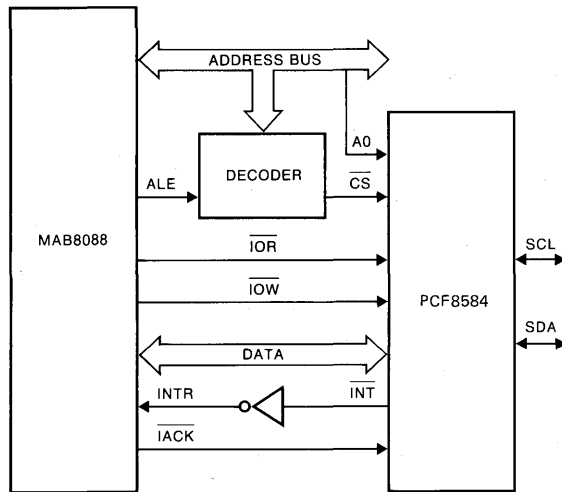

7Z28115

Fig.13 Application diagram using the 8088.

# I<sup>2</sup>C-bus controller

# PCF8584

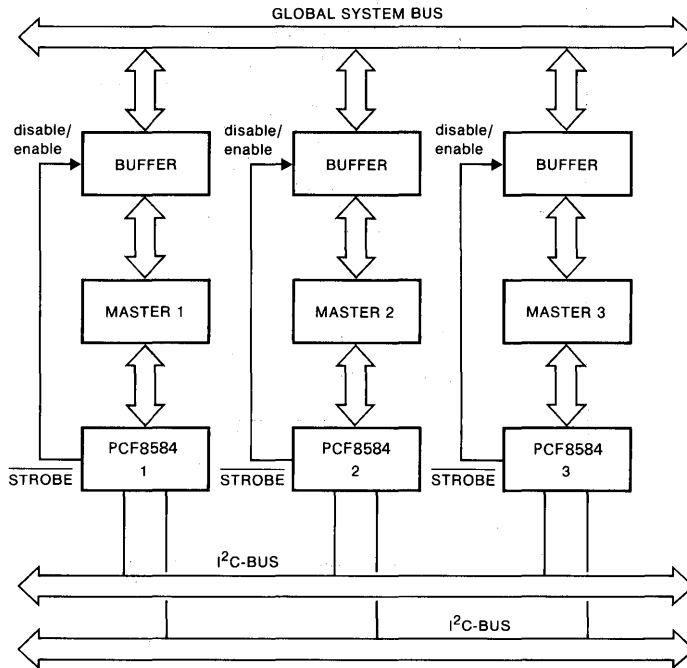

7Z28118

Fig.14 STROBE as bus access controller.



Purchase of Philips' I<sup>2</sup>C components conveys a license under the Philips' I<sup>2</sup>C patent to use the components in the I<sup>2</sup>C-system provided the system conforms to the I<sup>2</sup>C specifications defined by Philips.

# Universal sync generator (USG)

# SAA1101

## FEATURES

- Programmable to seven standards
- Additional outputs to simplify signal processing
- Can be synchronized to an external sync. signal
- Option to select the 524/624 line mode instead of the 525/625 line mode
- Lock from subcarrier to line frequency

## GENERAL DESCRIPTION

The SAA1101 is a Universal Sync Generator (USG) and is designed for application in video sources such as cameras, film scanners, video generators and associated apparatus. The circuit can be considered as a successor to the SAA1043 sync generator and the SAA1044 subcarrier coupling IC.

## QUICK REFERENCE DATA

SYMBOL	PARAMETER	MIN.	MAX.	UNIT
$V_{DD}$	supply voltage range (pin 28)	4.5	5.5	V
$I_{DD}$	quiescent supply current	–	10	$\mu$ A
$f_{OSC}$	clock oscillator frequency	–	24	MHz

## ORDERING AND PACKAGE INFORMATION

EXTENDED TYPE NUMBER	PACKAGE			
	PINS	PIN POSITION	MATERIAL	CODE
SAA1101P	28	DIL	plastic	SOT117
SAA1101T	28	SO28	plastic	SOT136A

Universal sync generator (USG)

SAA1101

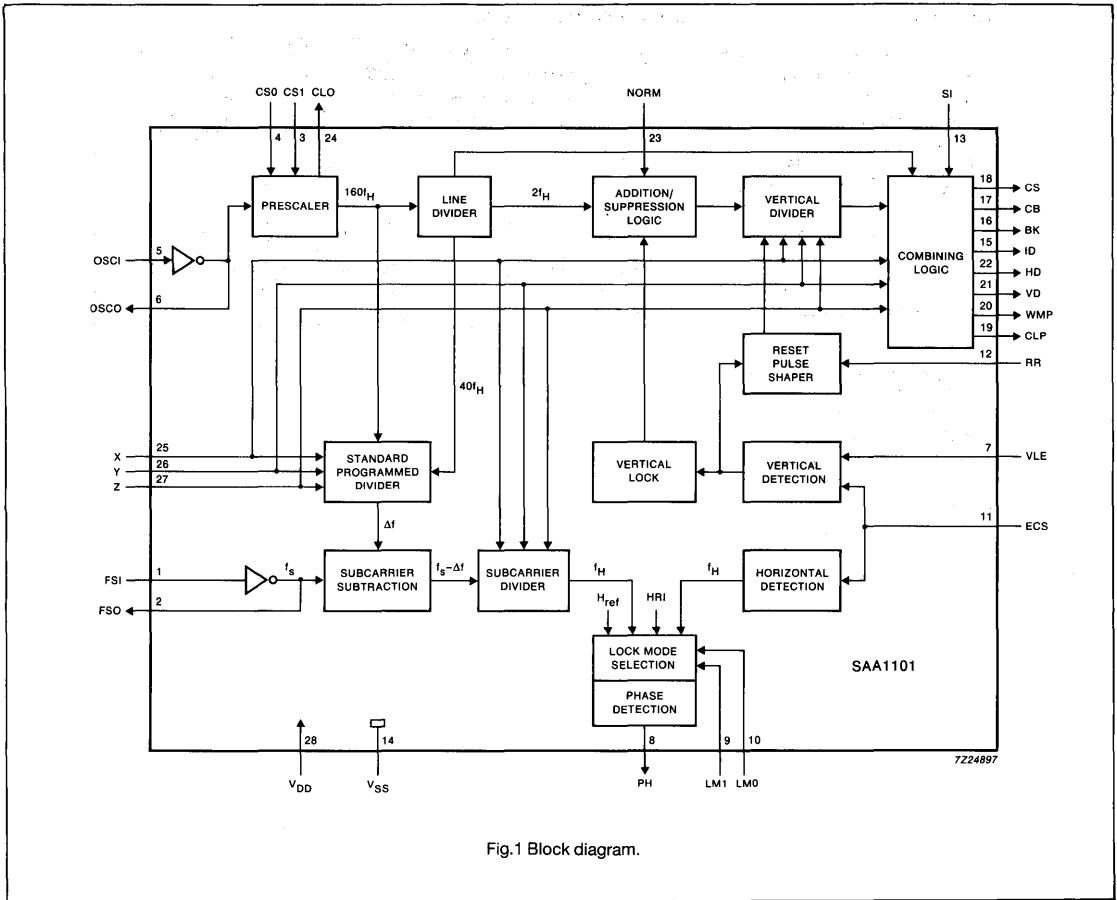

Fig.1 Block diagram.

# Universal sync generator (USG)

SAA1101

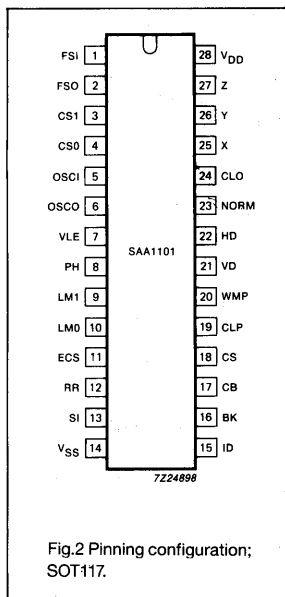

Fig.2 Pinning configuration; SOT117.

## FUNCTIONAL DESCRIPTION

### Generation of pulses

Generation of standard pulses such as sync, blanking and burst for TV systems: PAL B/G, PALN, PALM, SECAM and NTSC. In addition a number of non-standard pulses have been supplied to simplify signal processing. These signals include – horizontal drive, vertical drive, clamp pulse, identification etc. It is possible to select the 524/624 line mode instead of the 525/625 line mode for all the above TV systems for applications such as robotics, games and computers.

## PINNING

SYMBOL	PIN	DESCRIPTION
FSI	1	subcarrier oscillator input, where $f_{max} = 5$ MHz
FSO	2	subcarrier oscillator output
CS1	3	clock frequency selection – CMOS input
CS0	4	clock frequency selection – CMOS input
OSCI	5	clock oscillator input, where $f_{max} = 24$ MHz
OSCO	6	clock oscillator output
VLE	7	vertical in-lock enable – CMOS input
PH	8	phase detector output – 3-state output
LM1	9	lock mode selection – CMOS input
LM0	10	lock mode selection – CMOS input
ECS	11	external composite sync. signal – CMOS Schmitt-trigger input
RR	12	frame reset – CMOS Schmitt-trigger input
SI	13	set identification, used to set the correct field sequence in PAL-mode. The correction (inversion of fh2) is done at the left-hand slope of the SI-pulse. Minimum pulse width is 800 ns. CMOS Schmitt-trigger input.
VSS	14	ground
ID	15	identification – push-pull output
BK	16	burst key (PAL/NTSC), chroma-blanking (SECAM) – push-pull output
CB	17	composite blanking – push-pull output
CS	18	composite sync. – push-pull output
CLP	19	clamp pulse – push-pull output
WMP	20	white measurement pulse – 3-state output
VD	21	vertical drive pulse – push-pull output
HD	22	horizontal drive pulse – push-pull output
NORM	23	used with X, Y and Z to select TV system; NORM = 0, 625/525 line mode (standard); NORM = 1, 624/524 line mode – CMOS input
CLO	24	clock output – push-pull output
X	25	TV system selection input – CMOS input
Y	26	TV system selection input – CMOS input
Z	27	TV system selection input – CMOS input
VDD	28	voltage supply

# Universal sync generator (USG)

SAA1101

### Lock modes

The USG offers four lock modes:

- Lock from the subcarrier
- Slow sync. lock, external  $H_{ref}$
- Slow sync. lock, internal  $H_{ref}$
- Fast sync. lock, internal  $H_{ref}$

### LOCK FROM SUBCARRIER

Lock from subcarrier to the line frequency for the above mentioned TV systems is given below; the horizontal frequency ( $f_H$ ) = 15.625 kHz for 625 line systems and 15.734264 kHz for 525 line systems.

SECAM (1 and 2)	$282f_H$
PALN	$229.2516f_H$
NTSC (1 and 2)	$227.5f_H$
PALM	$227.25f_H$
PAL B/G	$283.7516f_H$

These relationships are obtained by the use of a phase locked loop and the internal programmed divider chain, see Fig. 3(a).

### LOCK TO AN EXTERNAL SIGNAL SOURCE

The following methods can be used to lock to an external signal source:

1. Sync. lock slow; the line frequency is locked to an external signal. The line and frame information are extracted from the external sync. signal and used separately in the lock system. The line information is used in a phase-locked loop where external and internal line frequencies are compared by the same phase detector as is used for the subcarrier lock. The external frame information is compared with the internal frame in a slow lock system; mismatch

of internal and external frames will result in the addition or suppression of one line depending on the direction of the fault. The maximum lock time for frame lock is 6.25 s, see Fig. 3(b).

2. Sync. lock fast. A fast lock of frames is possible with a frame reset which is extracted out of the incoming external sync. signal, see Fig. 3(c).
3. Sync. lock with external reference. Lock of an external sync. signal to the line frequency with an external line reference to make possible a shifted lock. The subcarrier input is, in this case, used as an external input for the horizontal reference, see Fig. 3(d).

### SELECTION OF LOCK MODE

Lock mode is selected using the inputs LM0 and LM1 as illustrated in the Table below.

LM0	LM1	SELECTION
0	0	lock to subcarrier
0	1	slow sync. lock external $H_{ref}$
1	0	slow sync. lock internal $H_{ref}$
1	1	fast sync. lock internal $H_{ref}$

The different lock modes are illustrated by the following figures:

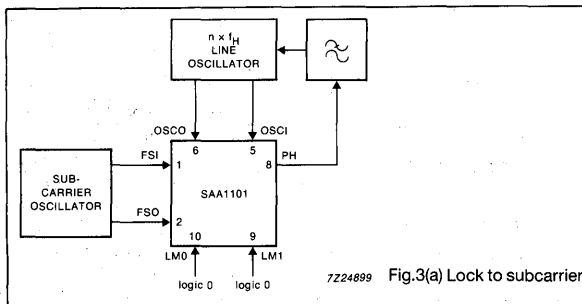

Fig.3(a) Lock to subcarrier.

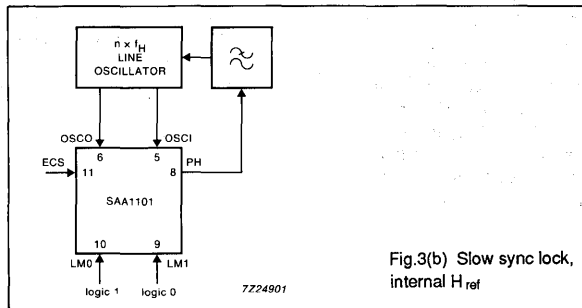

Fig.3(b) Slow sync lock, internal  $H_{ref}$



# Universal sync generator (USG)

# SAA1101

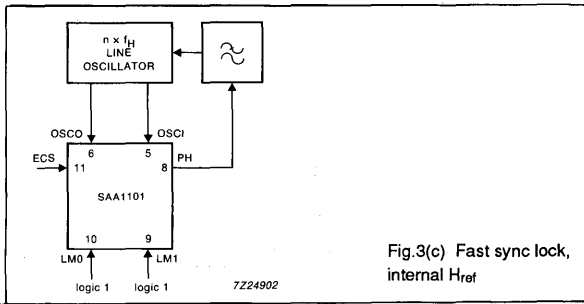

Fig.3(c) Fast sync lock, internal  $H_{ref}$

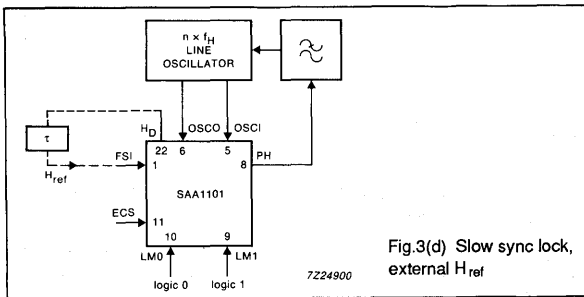

Fig.3(d) Slow sync lock, external  $H_{ref}$

LOCK WITH HORIZONTAL AND VERTICAL SIGNALS  
(slow lock modes only)

It is possible to use horizontal and vertical signals instead of composite sync signals. The connections in this situation are: the external horizontal signal is connected to the ECS input (pin 11) and the vertical signal to the RR input (pin 12). The HIGH time of the horizontal pulse must be less than 14.4  $\mu$ s, otherwise it will be detected as being a vertical pulse and will corrupt the vertical slow lock system.

### Selection of Clock Frequency

The clock frequency is selected using the CS0 and CS1 inputs as illustrated below.

CS0	CS1	FREQUENCY	625 LINES	525 LINES	UNITS
0	0	$160f_H$	2.5	2.517482	MHz
0	1	$320f_H$	5	5.034964	MHz
1	0	$960f_H$	15	15.104893	MHz
1	1	$1440f_H$	22.5	22.657340	MHz

Where the horizontal frequency,  $f_H = 15.625$  kHz for 625 lines and 15.734264 kHz for 525 lines.

# Universal sync generator (USG)

SAA1101

### Oscillators

The subcarrier oscillator has FSI as its input and FSO as its output. It is always used as a crystal oscillator with a series resonance crystal with parallel load capacitor. The maximum frequency,  $f_{max} = 5$  MHz and the load capacitor,  $C_L = 10 < C_L < 35$  pF.

The clock oscillator has OSC1 as its input and OSCO as its output. It can be used with an LC oscillator or a series resonance crystal with parallel load capacitor (Fig.4). The maximum frequency,  $f_{max} = 24$  MHz and the load capacitor,  $C_L = 10 < C_L < 35$  pF.

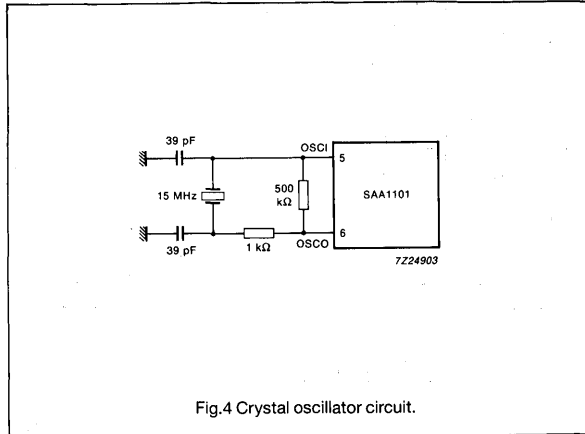

Fig.4 Crystal oscillator circuit.

### Selection of TV System

Selection of the required TV system is achieved by the X, Y and Z inputs as illustrated by the following Table.

SYSTEM	X	Y	Z
SECAM1	0	0	0
PALN	0	0	1
NTSC1	0	1	0
PALM	0	1	1
SECAM2	1	0	0 (with identifier)
PAL B/G	1	0	1
NTSC2	1	1	0 (short blanking)

### Selection of 625/525 (standard; interlaced mode) or 624/524 lines (non-interlaced mode)

Selection is achieved using the NORM input. When NORM = 0, 625/525 (standard) lines are selected; when NORM = 1, 624/524 line are selected.

### Output Dimensions

All push-pull outputs: standard output 2 mA.

White measurement pulse, WMP: 3-state output 2 mA.

Phase detector, PH: 3-state output 2 mA.

### LIMITING VALUES

Limiting values in accordance with the Absolute Maximum System (IEC 134)

SYMBOL	PARAMETER	MIN.	MAX.	UNIT
$V_{DD}$	supply voltage	-0.5	+7	V
$V_I$	input voltage	-0.5	$V_{DD} + 0.5$ *	V
$I_I$	maximum input current	-	$\pm 10$	mA
$I_O$	maximum output current	-	$\pm 10$	mA
$I_{DD}$	maximum supply current in $V_{DD}$	-	25	mA
$P_{tot}$	maximum power dissipation	-	400	mW
$T_{stg}$	storage temperature range	-55	+150	°C

\* Input voltage should not exceed 7 V.

## Universal sync generator (USG)

SAA1101

## CHARACTERISTICS

 $V_{DD} = 4.5$  to  $5.5$  V;  $T_{amb} = -25$  to  $+70$  °C unless otherwise specified

SYMBOL	PARAMETER	CONDITIONS	MIN.	TYP.	MAX.	UNIT
<b>Supplies</b>						
$V_{DD}$	supply voltage		4.5	-	5.5	V
$I_{DD}$	supply current (quiescent)	$T_{amb} = 25$ °C	-	-	10	$\mu$ A
<b>Inputs</b>						
$\pm I_I$	input leakage current	$T_{amb} = 25$ °C	-	-	100	nA
CMOS COMPATIBLE; X, Y, Z, NORM, CS0, CS1, LM0, LM1 AND VLE						
$V_{IH}$	input voltage HIGH		$0.7V_{DD}$	-	-	V
$V_{IL}$	input voltage LOW		-	-	$0.3V_{DD}$	V
SCHMITT TRIGGER INPUTS; ECS, RR AND SI						
$V_{T+}$	positive-going threshold		-	2.5	4	V
$V_{T-}$	negative-going threshold		1	1.5	-	V
$V_H$	hysteresis		0.4	1	-	V
OSCILLATOR INPUTS; OSCI AND FSI						
$V_{IH}$	input voltage HIGH		$0.7V_{DD}$	-	-	V
$V_{IL}$	input voltage LOW		-	-	$0.3V_{DD}$	V
<b>Outputs</b>						
PUSH-PULL OUTPUTS; CB, CS, BK, ID, HD, VD, CLP AND CLO						
$V_{OH}$	output voltage HIGH	$-I_O = 2$ mA; $V_{DD} = 5$ V	4.5	-	-	V
$V_{OL}$	output voltage LOW	$I_O = 2$ mA; $V_{DD} = 5$ V	-	-	0.5	V
OSCILLATOR OUTPUTS; OSCO AND FSO						
$V_{OH}$	output voltage HIGH	$-I_O = 0.75$ mA; $V_{DD} = 5$ V	4.5	-	-	V
$V_{OL}$	output voltage LOW	$I_O = 0.75$ mA; $V_{DD} = 5$ V	-	-	0.5	V
3-STATE OUTPUTS; WMP AND PH						
$V_{OH}$	output voltage HIGH	$-I_O = 2$ mA; $V_{DD} = 5$ V	4.5	-	-	V
$V_{OL}$	output voltage LOW	$I_O = 2$ mA; $V_{DD} = 5$ V	-	-	0.5	V
$\pm I_{OZ}$	OFF-state current	$T_{amb} = 25$ °C	-	-	50	nA

# Universal sync generator (USG)

SAA1101

## OUTPUT WAVEFORMS

The output waveforms for the different modes of operation are illustrated by Figs 5 and 6.

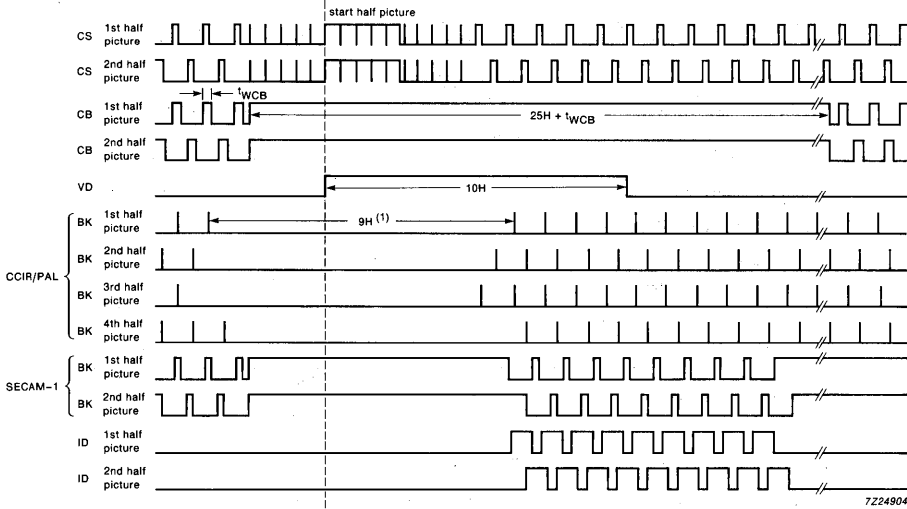

(1) H = 1 horizontal scan.

Fig.5 Typical output waveforms for PAL/CCIR and SECAM. In the 624-line mode the output waveforms are identical to the first half picture of PAL/CCIR and are not interlaced.

Universal sync generator (USG)

SAA1101

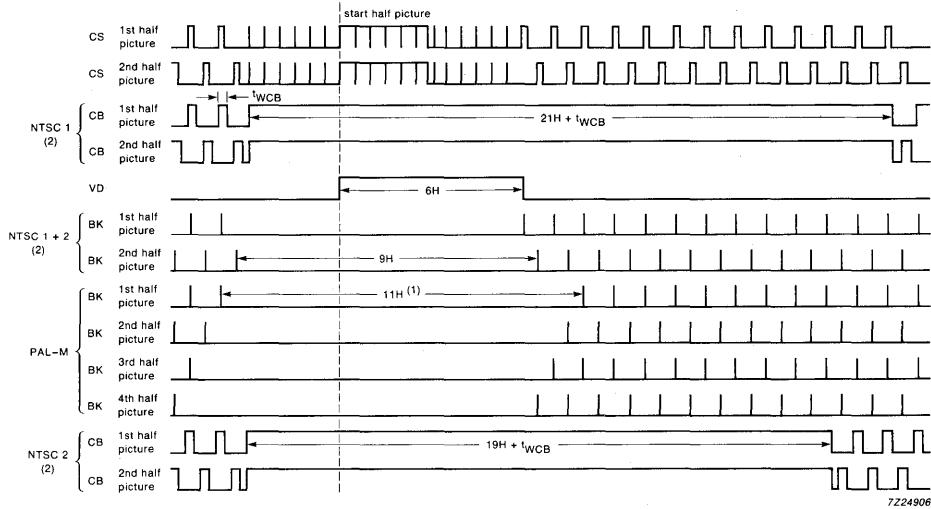

- (1) H = 1 horizontal scan.
- (2) NTSC mode reset; the fourth half picture is identical to the second half picture for NTSC.

Fig.6 Typical output waveforms for NTSC and PAL-M. In the 524-line mode the output waveforms are identical to the first half picture of NTSC and are not interlaced.

## Universal sync generator (USG)

SAA1101

**WAVEFORM TIMING**

The waveform timing depends on the frequency of the oscillator input ( $f_{OSCI}$ ). This is illustrated in the table below as the number (N) of oscillations at OSCI. The timings are derived from  $N \times t_{OSCI} \pm 100$  ns.

One horizontal scan (H) =  $320 \times t_{OSCI} = 1/f_H$ .

Where  $t_{OSCI} = 200$  ns for PAL/SECAM and 198.6 ns for NTSC/PAL-M

SYMBOL	PARAMETER	PAL	NTSC	PAL-M	SECAM	UNIT	N
<b>Composite sync (CS)</b>							
$t_{WSC1}$	horizontal sync pulse width	4.8	4.77	4.77	4.8	$\mu$ s	24
$t_{WSC2}$	equalizing pulse width	2.4	2.38	2.38	2.4	$\mu$ s	12
$t_{WSC3}$	serration pulse width	4.8	4.77	4.77	4.8	$\mu$ s	24
-	duration of pre-equalizing pulses	2.5	3	3	2.5	H	-
-	duration of post-equalizing pulses	2.5	3	3	2.5	H	-
-	duration of serration pulses	2.5	3	3.5	2.5	H	-
<b>Composite blanking (CB)</b>							
HORIZONTAL BLANKING PULSE WIDTH							
$t_{WCB}$	PAL/SECAM/PAL-M	12	-	11.12	12	$\mu$ s	60
$t_{WCB}$	NTSC1	-	11.12	-	-	$\mu$ s	56
$t_{WCB}$	NTSC2	-	10.53 *	-	-	$\mu$ s	53
FRONT PORCH							
$t_{PCBCS}$	front porch	1.6	1.59	1.59	1.6	$\mu$ s	8
DURATION OF VERTICAL BLANKING							
-	PAL/SECAM/PAL-M	$25H + t_{WCB}$	-	$21H + t_{WCB}$	$25H + t_{WCB}$	-	-
-	NTSC1	-	$21H + t_{WCB}$	-	-	-	-
-	NTSC2	-	$19H + t_{WCB}$	-	-	-	-
<b>Burst key (BK) (not SECAM)</b>							
$t_{WBK}$	burst key pulse width	2.4	2.38	2.38	-	$\mu$ s	12
$t_{PCSBK}$	CS to burst key delay	5.6	5.56	5.76	-	$\mu$ s	28
-	burst suppression	9	9	11	-	H	-

\* Horizontal blanking pulse width for NTSC2 can be 11.12  $\mu$ s maximum

## Universal sync generator (USG)

SAA1101

SYMBOL	PARAMETER	PAL	NTSC	PAL-M	SECAM	UNIT	N
<b>Burst key (BK) (not SECAM) (continued)</b>							
POSITION OF BURST SUPPRESSION							
-	first half picture	H623 to H6	H523 to H6	H523 to H8	-	-	-
-	second half picture	H310 to H318	H261 to H269	H260 to H270	-	-	-
-	third half picture	H622 to H5	H523 to H6	H522 to H7	-	-	-
-	fourth half picture	H311 to H319	H261 to H269	H259 to H269	-	-	-
<b>Burst key (BK) (SECAM)</b>							
$t_{WBK}$	chroma pulse width	-	-	-	7.2	$\mu\text{s}$	36
$t_{PBKCS}$	CS to chroma delay	-	-	-	1.6	$\mu\text{s}$	8
DURATION OF VERTICAL BLANKING							
-	SECAM1	-	-	-	note 1	-	-
-	SECAM2	-	-	-	note 2	-	-
<b>Clamp pulse (CLP)</b>							
$t_{WCLP}$	clamp pulse width	2.4	2.38	2.38	2.4	$\mu\text{s}$	12
$t_{PCSLP}$	CS to CLP delay	1.6	1.59	1.59	1.6	$\mu\text{s}$	8
<b>Horizontal drive (HD)</b>							
$t_{WHD}$	pulse width	7.2	7.15	7.15	7.2	$\mu\text{s}$	36
$t_{PHDCS}$	CS to HD delay	0.8	0.79	0.79	0.8	$\mu\text{s}$	4
-	repetition period	64	63.56	63.56	64	$\mu\text{s}$	-
<b>Vertical drive (VD)</b>							
-	VD duration	10	6	6	10	H	-
$t_{PVDCS}$	CS to VD delay	1.6	1.59	1.59	1.6	$\mu\text{s}$	8
<b>White measurement pulse (WMP)</b>							
-	pulse width	2.4	2.38	2.38	2.4	$\mu\text{s}$	12
-	CS to WMP delay	34.4	34.16	34.16	34.4	$\mu\text{s}$	172
-	duration of WMP	10	9	9	10	H	-

## Teletext video processor

SAA5191

## FEATURES

- Adaptive data slicer
- Crystal-controlled data clock regeneration with a bit rate of 6.9375 MHz
- Adaptive sync separator, horizontal phase detector and 13.5 MHz VCO to provide display phase locked loop (PLL)
- TV synchronization at teletext mode

## QUICK REFERENCE DATA

SYMBOL	PARAMETER	MIN.	TYP.	MAX.	UNIT
$V_P$	supply voltage (pin 16)	-	12	-	V
$I_P$	supply current	-	70	-	mA
$V_i$ CVBS	CVBS input signal on pin 27 (peak-to-peak value)				
	at pin 2 LOW	-	1	-	V
	at pin 2 open-circuit	-	2.5	-	V
$V_o$	output signals TTC and TTD (peak-to-peak value, pins 14, 15)	2.5	3.5	4.5	V
$V_{F13}$	13.5 MHz clock output signal (peak-to-peak value, pin 17)	1	2	3	V
$V_{SYNC}$	video sync output signal (peak-to-peak value, pin 1)	-	-	1	V
	SYNC output signal $\overline{TCS}$	200	450	650	mV
VCS	video composite sync level on output pin 25				
	LOW	-	-	0.4	V
	HIGH	2.4	-	5.5	V
$T_{amb}$	operating ambient temperature	0	-	+70	°C

## GENERAL DESCRIPTION

The SAA5191 is a bipolar integrated circuit that extracts teletext data from the video signal (CVBS), regenerates the teletext clock (TTC) and synchronizes the text display to the television signals (VCS). This device operates in conjunction with the Digital Video Teletext (back-end) Decoder (DVTB – SAA9042A) or any other compatible device.

## ORDERING AND PACKAGE INFORMATION

EXTENDED TYPE NUMBER	PACKAGE			
	PINS	PIN POSITION	MATERIAL	CODE
SAA5191	28	DIL	plastic	SOT117



# Teletext video processor

# SAA5191

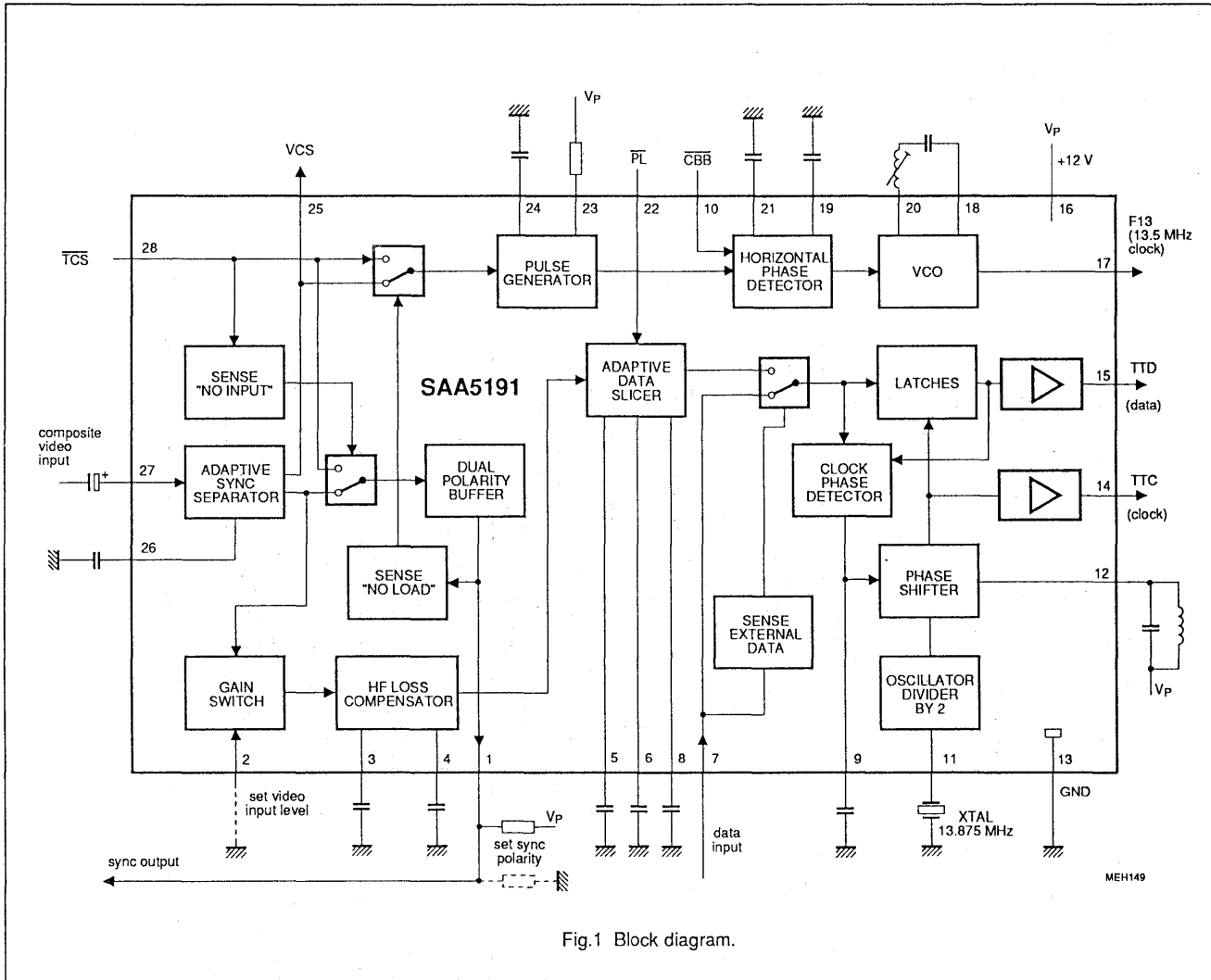

Fig.1 Block diagram.

## Teletext video processor

SAA5191

## PINNING

SYMBOL	PIN	DESCRIPTION
STTV	1	sync output signal to TV (positive or negative going)
VILS	2	level select input of video input (LOW equals 1 V)
C <sub>filt</sub>	3	video filtering capacitor of HF loss compensation
C <sub>store</sub>	4	HF storage capacitor
C <sub>ampl</sub>	5	amplitude capacitor
C <sub>zero</sub>	6	zero level capacitor
EXD	7	external data current input (1)
C <sub>time</sub>	8	data timing capacitor for the adaptive data slicer
C <sub>CLK</sub>	9	clock phase detector capacitor
C <sub>BB</sub>	10	blanking insertion input
XTAL	11	13.875 MHz crystal (double of data rate)
CLF	12	6.9375 MHz clock frequency filter
GND	13	ground (0 V)
TTC	14	teletext clock output (for computer controlled teletext)
TTD	15	teletext data output (for computer controlled teletext)
V <sub>P</sub>	16	+12 V supply voltage
F13	17	13.5 MHz VCO output (for sandcastle generation)
OSCO	18	oscillator output to series LC-circuit or crystal
C <sub>VCR</sub>	19	short time constant capacitor at video recorder mode (2)
OSCI	20	oscillator input from series LC-circuit or crystal
C <sub>hor</sub>	21	horizontal phase capacitor / VCR mode
PL	22	sandcastle input (generated in CCT)
R <sub>T</sub>	23	timing resistor for pulse generator
C <sub>T</sub>	24	timing capacitor for pulse generator
VCS	25	video composite sync output to CCT
C <sub>BL</sub>	26	black level capacitor
CVBS	27	composite video input signal from TV
TCS	28	text-composite/scan-composite sync input (TSC/SCS)

## Notes to the pinning

- (1) Sliced teletext data from external: active HIGH level (current), low impedance input.
- (2) While the loop is locking up.

## PIN CONFIGURATION

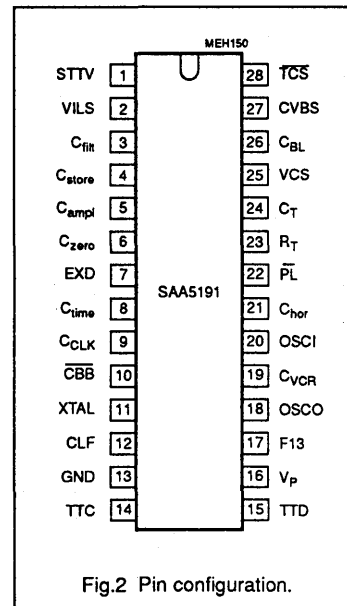

## Teletext video processor

SAA5191

**LIMITING VALUES**

In accordance with the Absolute Maximum System (IEC 134).

SYMBOL	PARAMETER	MIN.	MAX.	UNIT
$V_P$	supply voltage (pin 16)	0	13.2	V
$V_5$	voltage on pin 5	0	5.5	V
$T_{stg}$	storage temperature range	-20	125	°C
$T_{amb}$	operating ambient temperature range	0	+70	°C

**CHARACTERISTICS** $V_P = 12\text{ V}$ ;  $T_{amb} = 25\text{ °C}$  and measurements taken in Fig.3, unless otherwise specified.

SYMBOL	PARAMETER	CONDITIONS	MIN.	TYP.	MAX.	UNIT
$V_P$	supply voltage range (pin 16)		10.8	12.0	13.2	V
$I_P$	supply current		50	70	105	mA
<b>Video input, sync separator and data slicer</b>		$Z_S \leq 250\ \Omega$				
$V_1$ CVBS	input signal sync to white (peak-to-peak value, pin 27)	$V_2 = \text{LOW}$	0.7	1	1.4	V
		$V_2 = \text{HIGH}$	1.75	2.5	3.5	V
	sync amplitude (peak-to-peak value)		0.1	-	1	V
		data slicing level	$V_2 = \text{LOW}$	0.3	0.46	0.7
		$V_2 = \text{HIGH}$	0.75	1.15	1.75	V
$V_2$	input voltage LOW (pin 2)		0	-	0.8	V
	input voltage HIGH	open-circuit equals HIGH	2.0	-	5.5	V
$I_2$	input current LOW		0	-	-150	$\mu\text{A}$
	input current HIGH	$V_2 < 5.5\text{ V}$	0	-	1	mA
<b>Teletext data output (TTD)</b>						
$V_{22}$	phase lock pulse (PL) input voltage (peak-to-peak value, pin 22)	phase locked	0	-	3	V
		phase unlocked	3.9	-	5.5	V
$V_o$ TTD	data output signal on pin 15 (peak-to-peak value)		2.5	3.5	4.5	V
$V_{15}$	DC output voltage	mean level	3	4	5	V
$C_L$	load capacitance on pin 15		-	-	40	pF
$t_r, t_f$	rise and fall time		20	30	45	ns
<b>Teletext clock output (TTC)</b>						
$V_o$ TTC	clock output signal on pin 14 (peak-to-peak value)		2.5	3.5	4.5	V
$V_{14}$	DC output voltage	mean level	3	4	5	V
$C_L$	load capacitance on pin 14		-	-	40	pF

## Teletext video processor

SAA5191

SYMBOL	PARAMETER	CONDITIONS	MIN.	TYP.	MAX.	UNIT
$t_r, t_f$	rise and fall time		20	30	45	ns
$t_d$	delay time of falling edge relative to other edges of TTD		-	-	$\pm 20$	ns
<b>Text/ scan composite sync input (<math>\overline{TCS}/\overline{SCS}</math>)</b>						
$V_{28}$	input voltage LOW for $\overline{TCS}$ (pin 28)		0	-	0.8	V
	input voltage HIGH for $\overline{TCS}$		2.0	-	7.0	V
	input voltage LOW for $\overline{SCS}$		0	-	1.5	V
	input voltage HIGH for $\overline{SCS}$		3.5	-	7.0	V
$I_{28}$	input current	$V_{28} = 0$ to 7 V	-40	-70	-100	$\mu\text{A}$
		$V_{28} = 10$ to $V_P$	-	-	$\pm 5$	$\mu\text{A}$
<b>SYNC output buffer</b>						
$V_o$	CVBS sync output signal on pin 1 (peak-to-peak value)	$R_{L1} = 1.2 \text{ k}\Omega$ to $V_P$	-	-	1	V
	$\overline{TCS}$ output signal	$R_{L1} = 1.2 \text{ k}\Omega$ to GND	200	450	650	mV
$V_1$	DC output voltage at positive sync signal	$R_{L1} = 1.2 \text{ k}\Omega$ to GND	1.0	1.4	2.0	V
	DC output voltage at negative sync signal	$R_{L1} = 1.2 \text{ k}\Omega$ to $V_P$	9.0	10.1	11.0	V
$I_1$	output current		-	-	$\pm 3$	mA
<b>Video composite sync output (VCS)</b>						
$V_{25}$	output voltage LOW (pin 25)		0	-	0.4	V
	output voltage HIGH		2.4	-	5.5	V
$I_{25}$	output current LOW		0	-	0.5	mA
	output current HIGH		0	-	-1.5	mA
$t_d$	sync separator delay time		250	350	400	ns
<b>Horizontal phase detector and 13.5 MHz VCO</b>						
$V_{10}$	input voltage LOW ( $\overline{CBB}$ ), pin 10	blanking inserted	0	-	0.5	V
	blanking insertion HIGH	no blanking	1.0	-	5.5	V
$I_{10}$	input current		-	-	-5	$\mu\text{A}$
$V_o$	13.5 MHz clock output signal (peak-to-peak value, pin 17)		1	2	3	V
$V_{17}$	DC output voltage	maximum swing	4	-	8.5	V
$C_L$	load capacitance on pin 17		-	-	40	pF
$t_r, t_f$	rise and fall time		10	-	30	ns

Teletext video processor

SAA5191

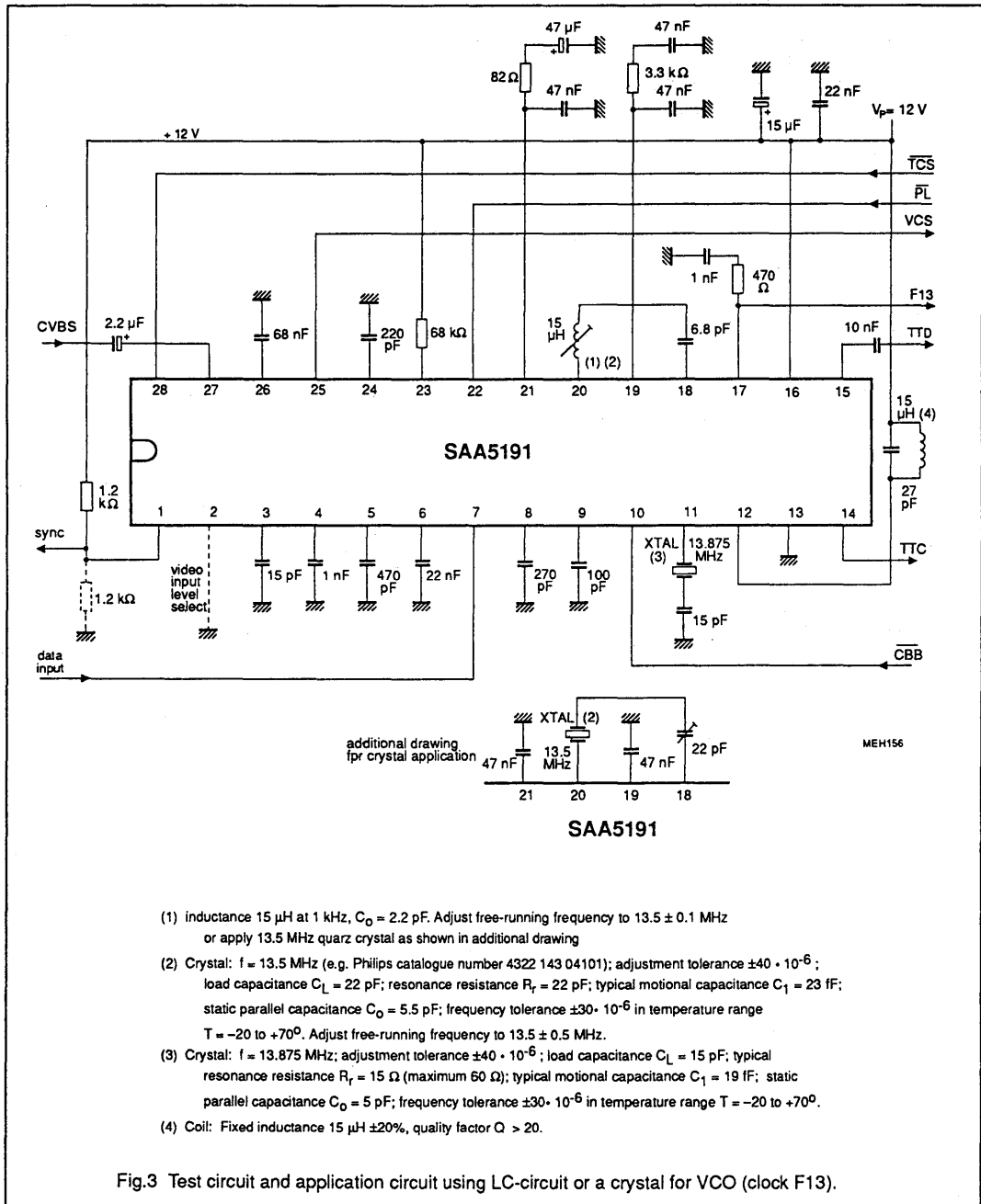

# Teletext video processor

# SAA5231

## GENERAL DESCRIPTION

The SAA5231 is a bipolar integrated circuit intended as a successor to the SAA5030. It extracts Teletext Data from the video signal, regenerates Teletext Clock and synchronizes the text display to the television syncs. The integrated circuit is intended to work in conjunction with CCT (Computer Controlled Teletext), EUROM or other compatible devices.

### Features

- Adaptive data slicer
- Data clock regenerator
- Adaptive sync separator, horizontal phase detector and 6 MHz VCO forming display phase locked loop (PLL)

### QUICK REFERENCE DATA

Supply voltage (pin 16)	$V_{CC}$	typ.	12 V
Supply current (pin 16)	$I_{CC}$	typ.	70 mA
Video input amplitude (pin 27) (peak-to-peak value)			
pin 2 LOW	$V_{27-13(p-p)}$	typ.	1 V
pin 2 HIGH	$V_{27-13(p-p)}$	typ.	2,5 V
Storage temperature range	$T_{stg}$		-20 to + 125 °C
Operating ambient temperature range	$T_{amb}$		0 to + 70 °C

### PACKAGE OUTLINE

28-lead dual in-line; plastic (SOT117).

# Teletext video processor

## SAA5231

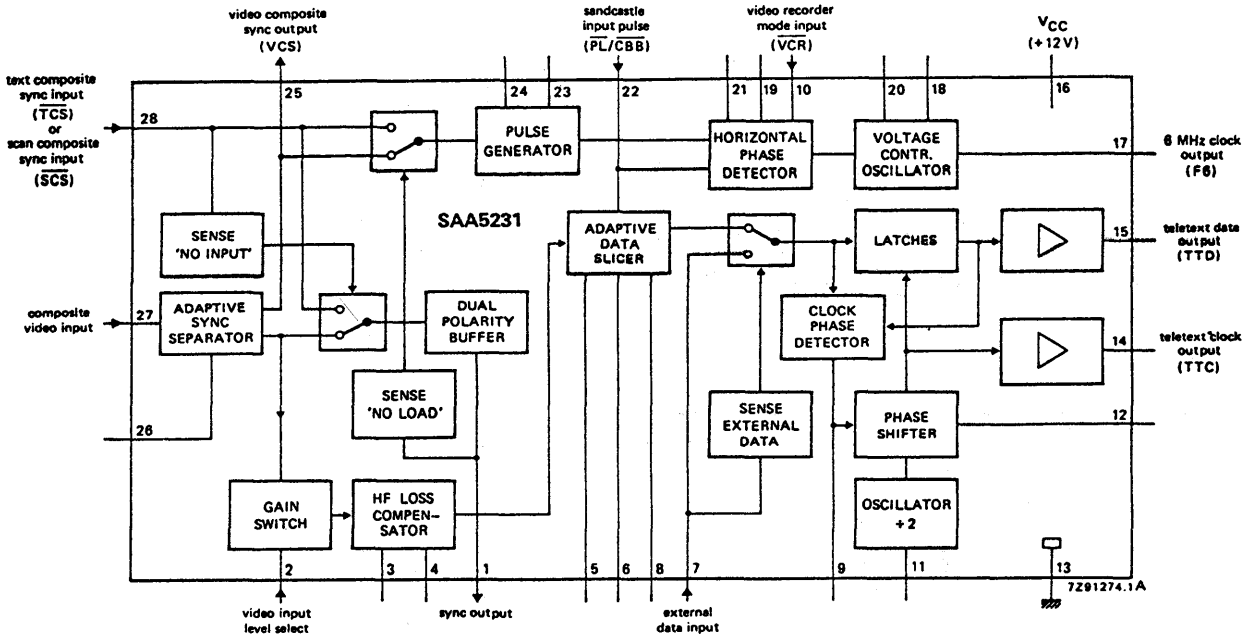

Fig. 1 Block diagram.

Teletext video processor

SAA5231

PINNING

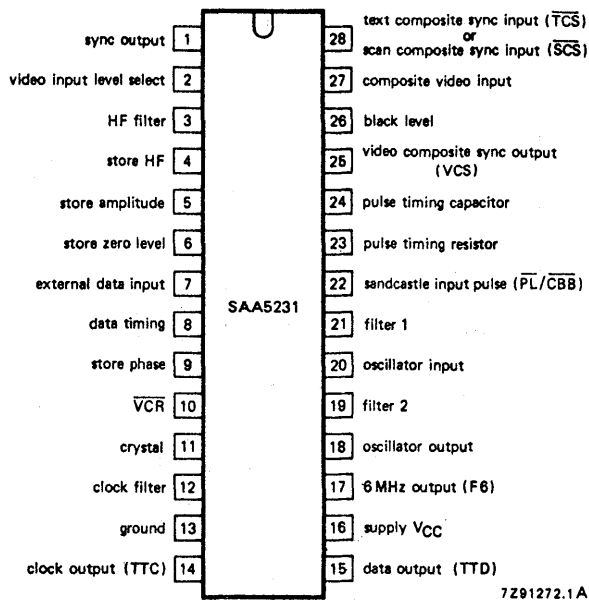

Fig. 2 Pinning diagram.

RATINGS

Limiting values in accordance with the Absolute Maximum System (IEC 134)

Supply voltage (pin 16)	$V_{CC}$	max. 13,2 V
Storage temperature range	$T_{stg}$	-20 to + 125 °C
Operating ambient temperature	$T_{amb}$	0 to + 70 °C



## Teletext video processor

SAA5231

## CHARACTERISTICS

$V_{CC} = 12\text{ V}$ ;  $T_{amb} = 25\text{ }^{\circ}\text{C}$  with external components as shown in application circuits unless otherwise stated.

parameter	symbol	min.	typ.	max.	unit
<b>Supply (pin 16)</b>					
Supply voltage	$V_{CC}$	10,8	12,0	13,2	V
Supply current	$I_{CC}$	50	70	105	mA
<b>Video input and sync separator</b>					
Video input amplitude (sync to white) (peak-to-peak value)					
video input select level LOW (pin 2)	$V_{27-13(p-p)}$	0,7	1	1,4	V
video input select level HIGH (pin 2)	$V_{27-13(p-p)}$	1,75	2,5	3,5	V
Source impedance	$ Z_s $	—	—	250	$\Omega$
Sync amplitude (peak-to-peak value)	$V_{27-13(p-p)}$	0,1	—	1	V
<b>Video input level select</b>					
Input voltage LOW	$V_{2-13}$	0	—	0,8	V
Input voltage HIGH	$V_{2-13}$	2,0	—	5,5	V
Input current LOW	$I_2$	0	—	-150	$\mu\text{A}$
Input current HIGH	$I_2$	0	—	1	mA
<b>Text composite sync input (<math>\overline{TCS}</math>)</b>					
Input voltage LOW	$V_{28-13}$	0	—	0,8	V
Input voltage HIGH	$V_{28-13}$	2,0	—	7,0	V
<b>Scan composite sync input (<math>\overline{SCS}</math>)</b>					
Input voltage LOW	$V_{28-13}$	0	—	1,5	V
Input voltage HIGH	$V_{28-13}$	3,5	—	7,0	V
<b>Select video sync from pin 1</b>					
Input current (pin 28)					
at $V_{28} = 0$ to 7 V	$I_{28}$	-40	-70	-100	$\mu\text{A}$
at $V_{28} = 10\text{ V}$ to $V_{CC}$	$I_{28}$	-5	—	+5	$\mu\text{A}$
<b>Video composite sync output (VCS)</b>					
Output voltage LOW	$V_{25-13}$	0	—	0,4	V
Output voltage HIGH	$V_{25-13}$	2,4	—	5,5	V
D.C. output current LOW	$I_{25}$	—	—	0,5	mA
D.C. output current HIGH	$I_{25}$	—	—	-1,5	mA
Sync separator delay time	$t_d$	0,25	0,35	0,40	$\mu\text{s}$

## Teletext video processor

SAA5231

parameter	symbol	min.	typ.	max.	unit
<b>Dual polarity buffer output</b>					
TCS amplitude (peak-to-peak value)	V <sub>1-13(p-p)</sub>	0,20	0,45	0,65	V
Video sync amplitude (peak-to-peak value)	V <sub>1-13(p-p)</sub>	—	—	1	V
Output current	I <sub>1</sub>	-3	—	+3	mA
D.C. output voltage					
R <sub>L</sub> to ground (0 V)	V <sub>1-13</sub>	1,0	1,4	2,0	V
R <sub>L</sub> to V <sub>CC</sub> (12 V)	V <sub>1-13</sub>	9,0	10,1	11,0	V
<b>Sandcastle input pulse (PL/CBB)</b>					
Phase lock pulse (PL)					
PL on (LOW)	V <sub>22-13</sub>	0	—	3	V
PL off (HIGH)	V <sub>22-13</sub>	3,9	—	5,5	V
Blanking pulse (CBB)					
CBB on (LOW)	V <sub>22-13</sub>	0	—	0,5	V
CBB off (HIGH)	V <sub>22-13</sub>	1,0	—	5,5	V
Input current	I <sub>22</sub>	-10	—	+10	μA
<b>Phase locked loop (PLL)</b>					
Phase detector timing					
Pulse duration					
using composite video	t <sub>p</sub>	2,0	2,4	2,8	μs
using scan composite sync	t <sub>p</sub>	3,0	3,5	4,0	μs
time PL must be LOW to make VCO run-free	t <sub>L</sub>	100	—	—	μs
<b>6 MHz clock output (F6)</b>					
A.C. output voltage (peak-to-peak value)	V <sub>17-13(p-p)</sub>	1	2	3	V
A.C. and d.c. output voltage range	V <sub>17-13(max)</sub>	4	—	8,5	V
Rise and fall time	t <sub>r</sub> ; t <sub>f</sub>	20	—	40	ns
Load capacitance	C <sub>17-13</sub>	—	—	40	pF
<b>Video recorder mode input (VCR)</b>					
VCR-mode on (LOW)	V <sub>10-13</sub>	0	—	0,8	V
VCR-mode off (HIGH)	V <sub>10-13</sub>	2,0	—	V <sub>CC</sub>	V
Input current	I <sub>10</sub>	-10	—	+10	μA

## Teletext video processor

SAA5231

parameter	symbol	min.	typ.	max.	unit
<b>Data slicer</b>					
Data amplitude of video input (pin 27)					
video input level select LOW (pin 2)	V <sub>27-13</sub>	0,30	0,46	0,70	V
video input level select HIGH (pin 2)	V <sub>27-13</sub>	0,75	1,15	1,75	V
<b>Teletext clock output</b>					
A.C. output voltage (peak-to-peak value)	V <sub>14-13(p-p)</sub>	2,5	3,5	4,5	V
D.C. output voltage (centre)	V <sub>14-13</sub>	3,0	4,0	5,0	V
Load capacitance	C <sub>L</sub>	—	—	40	pF
Rise and fall times	t <sub>r</sub> ; t <sub>f</sub>	20	30	45	ns
Delay of falling edge relative to other edges of TTD	t <sub>d</sub>	-20	0	+20	ns
<b>Teletext data output</b>					
A.C. output voltage (peak-to-peak value)	V <sub>15-13(p-p)</sub>	2,5	3,5	4,5	V
D.C. output voltage (centre)	V <sub>15-13</sub>	3,0	4,0	5,0	V
Load capacitance	C <sub>L</sub>	—	—	40	pF
Rise and fall times	t <sub>r</sub> ; t <sub>f</sub>	20	30	45	ns

Teletext video processor

SAA5231

APPLICATION INFORMATION

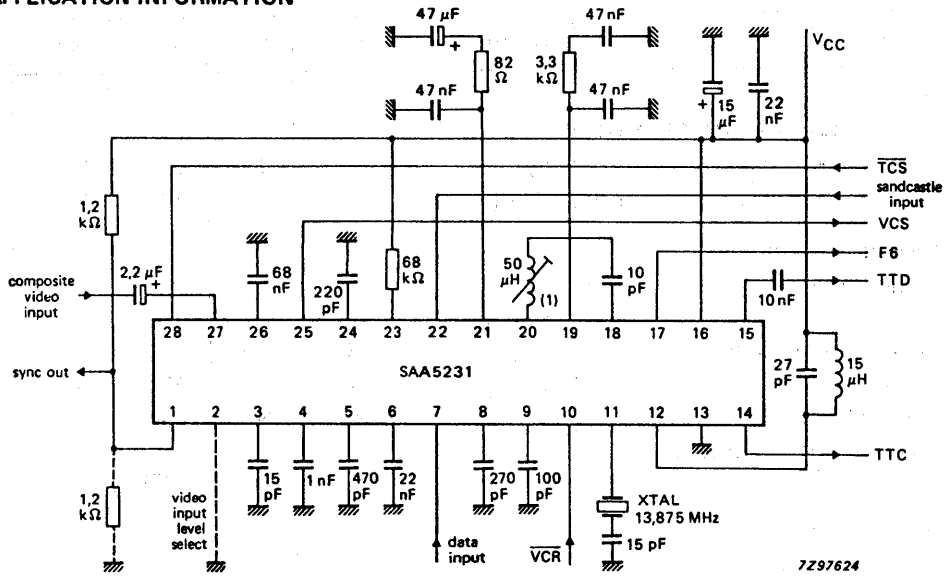

(1) Coil: 50 µH at 1 kHz,  $C_0 = 4$  pF. Adjust the free-running frequency to 6000 kHz ± 30 kHz.

Fig. 3a Application circuit using L/C circuit in PLL.

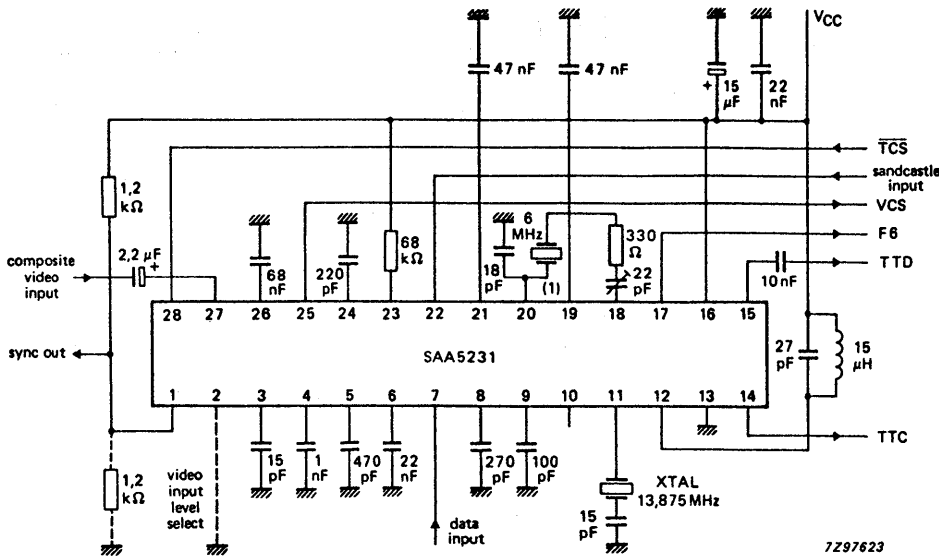

(1) Quartz crystal e.g. catalogue number 4322 143 04101. Adjust the free-running frequency to 6000,2 kHz ± 0,2 kHz.

Fig. 3b Application circuit using quartz crystal in PLL.

Teletext video processor

SAA5231

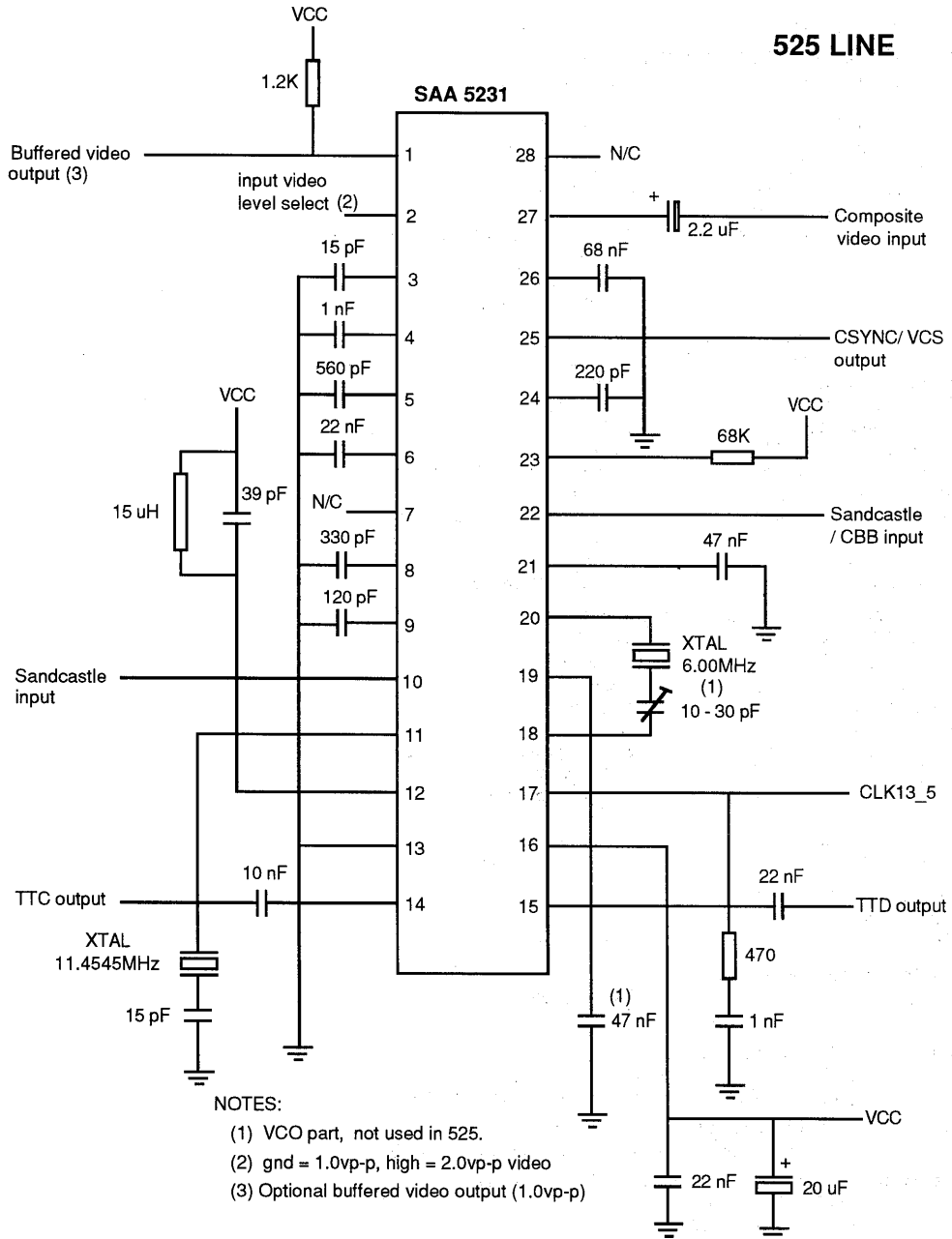

## Teletext video processor

SAA5231

**COMPONENT SPECIFICATION**

Specifications for crystal components for NTSC and PAL applications.

**Quartz crystal 525 line (11.4545MHz); Figures 3a and 3b**

Nominal Frequency	11.4545MHz
Frequency Tol @25°C	± 50ppm
Temperature Range	-20 to +70°C
Temperature Stability	± 30ppm
Load Capacitance (CL)	15 pF
Shunt Capacitance (Co)	5.0 pF typical, 7 pF maximum
Motion Capacitance (C1)	19 fF typical
Resonance Resistance (Rr)	10 Ohms typical, 60 Ohms maximum
Aging	± 5ppm/year
Mode of operation	Fundamental
Drive Level	100 µWatts Correlation

**Quartz crystal 565 line (13.875MHz); Figures 3a and 3b**

Nominal Frequency	13.875MHz
Frequency Tol @25°C	± 50ppm
Temperature Range	-20 to +70°C
Temperature Stability	± 30ppm
Load Capacitance (CL)	15 pF
Shunt Capacitance (Co)	5.0 pF typical, 7 pF maximum
Motion Capacitance (C1)	19 fF typical
Resonance Resistance (Rr)	10 Ohms typical, 60 Ohms maximum
Aging	± 5ppm/year
Mode of operation	Fundamental
Drive Level	100 µWatts Correlation

**Quartz crystal for VCO (6.00MHz); Figures 3a and 3b**

Nominal Frequency	6.00MHz
Frequency Tol @25°C	± 50ppm
Temperature Range	-20 to +70°C
Temperature Stability	± 50ppm
Load Capacitance (CL)	20 pF
Shunt Capacitance (Co)	5.5 pF typical, 7 pF maximum
Motion Capacitance (C1)	22 fF typical
Resonance Resistance (Rr)	10 Ohms typical, 60 Ohms maximum
Aging	± 5ppm/year
Mode of operation	Fundamental
Drive Level	100 µWatts Correlation

**Fixed Inductance; Figures 3a and 3b**

Inductance (L)	15 µH at 1KHz
Quality Factor (Q)	20 (minimum)

**Variable Inductance; Figure 3a**

Inductance (L)	15 µH at 1KHz
Static parallel capacitance (Co)	2.2 pF typical

The Philips part numbers for these crystals are:

4322 143 04890 (13.875MHz)

As of this publication, there is no part number specified for the 11.4545MHz crystal from Philips.

The Philips crystals can be obtained from:

Philips Components Passive Group, Phone (803) 772-2500

The crystals are also available from Ecliptek Inc. Their part numbers are:

ECX - 2384 - 11.4545MHz

ECX - 2383 - 13.875MHz

Ecliptek can be reached at (714) 433-1200. The sales contact is Mr. Rodney Mills.

The 15 µH inductor is available from Toko, and they can be reached at (408)432-8281. The part number is:

119ANA 5873HM

---

**Teletext video processor****SAA5231**

---

The function is quoted against the corresponding pin number.

**1. Synch output to TV**

Output with dual polarity buffer, a load resistor to 0V or +12V selects positive-going or negative-going syncs.

**2. Video input level select**

When this pin is LOW a 1V video input level is selected. When the pin is not connected it floats HIGH selecting a 2.5V video input level.

**3. HF filter**

The video signal for the h.f.-loss compensator is filtered by a 15pF capacitor connected to this pin.

**4. Store h.f.**

The h.f. amplitude is stored by a 1 nF capacitor connected to this pin.

**5. Store amplitude**

The amplitude for the adaptive data slicer is stored by a 470 pF capacitor connected to this pin.

**6. Store zero level**

The zero level for the adaptive data slicer is stored by a 22 nF capacitor connected to this pin.

**7. External data input**

Current input for sliced teletext data from external device.  
Active HIGH level (current), low impedance input.

**8. Data timing**

A 270 pF capacitor is connected to this pin for timing of the adaptive data slicer.

**9. Store phase**

The output signal from the clock phase detector is stored by a 100 pF capacitor connected to this pin.

**10. Video tape recorder mode (VCR)**

Signal input to command PLL into short time constant mode. Not used in application circuit Fig. 3b or Fig. 3c.

**11. Crystal**

A 13.875MHz crystal, 2 x data rate, connected in series with a 15 pF capacitor is applied via this pin to the oscillator and divide-by-two to provide the 6.9375MHz clock signal.

**12. Clock filter**

A filter for the 6.9375MHz clock signal is connected to this pin.

**13. Ground (0 V)****14. Teletext clock output (TTC)**

Clock output for CCT (Computer Controlled Teletext).

**15. Teletext data output (TTD)**

Data output for CCT.

**16. Supply voltage  $V_{CC}$  (+ 12V typ.)****17. Clock output (F6)**

6 MHz clock output for timing and sandcastle generation in CCT.

**18. Oscillator output (6 MHz)**

A series resonant circuit is connected between this pin and pin 20 to control the nominal frequency of the VCO.

**19. Filter 2**

A filter with a short time constant is connected to this pin for the horizontal phase detector. It is used in the video recorder mode and while the loop is locking up.

## Teletext video processor

SAA5231

**20. Oscillator input (6 MHz)**

See pin 18.

**21. Filter 1**

A filter with a long time constant is connected to this pin for the horizontal phase detector.

**22. Sandcastle input pulse (PL/CBB)**

This input accepts a sandcastle waveform, which is formed from PL and CBB from the CCT. Signal timing is shown in Fig. 4.

**23. Pulse timing resistor**

The current for the pulse generator is defined by a 68 k $\Omega$  resistor connected to this pin.

**24. Pulse timing capacitor**

The timing of the pulse generator is determined by a 220 pF capacitor connected to this pin.

**25. Video composite sync output (VCS)**

This output signal is for CCT.

**26. Black level**

The black level for the adaptive sync separator is stored by a 68 nF capacitor connected to this pin.

**27. Composite video input (CVS)**

The composite video signal is input via a 2.2  $\mu$ F clamping capacitor to the adaptive sync separator.

**28. Text composite sync input (TCS)/Scan composite sync input (SCS)**

TCS is input from CCT or SCS from external sync circuit. SCS is expected when there is no load resistor at pin 1. If pin 28 is not connected, the sync output on pin 1 will be the composite video input at pin 27, internally buffered.

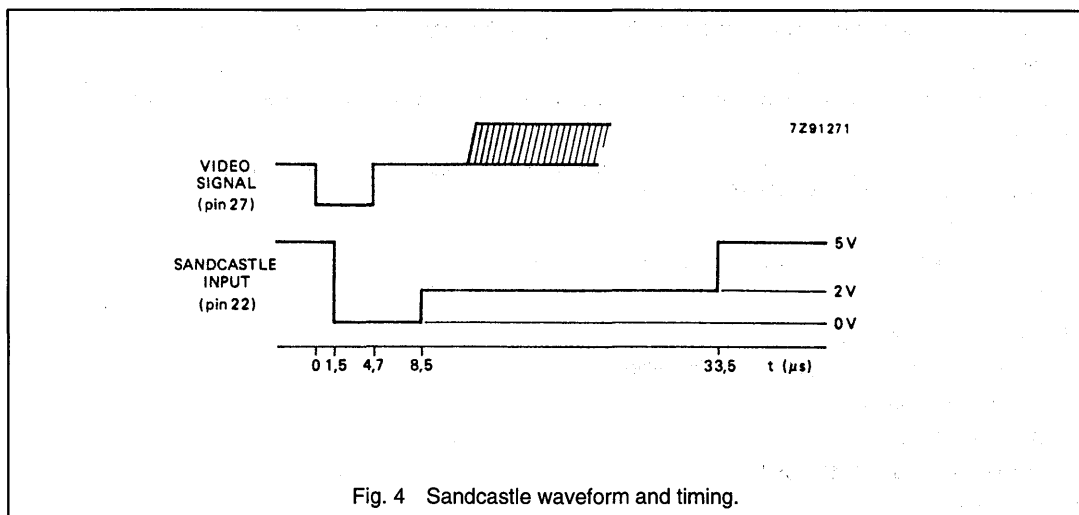



---

**Interface for data acquisition and control  
(for multi-standard teletext systems)**

---

**SAA5250****GENERAL DESCRIPTION**

The SAA5250 is a CMOS Interface for Data Acquisition and Control (CIDAC) designed for use in conjunction with the Video Input Processor (SAA5230) in a multi-standard teletext decoder. The device retrieves data from a user selected channel (channel demultiplexer), as well as providing control signals and consecutive addressing space necessary to drive a 2 K bytes buffer memory.

The system operates in accordance with the following transmission standards:

- French Didon Antiope specification D2 A4-2 (DIDON)
- North American Broadcast Teletext specification (NABTS)
- U.K. teletext (CEEFAX)

**Features**

- 7,5 MHz maximum conversion rate
- Three prefixes; DIDON, NABTS and U.K. teletext (CEEFAX)
- Mode without prefix
- Internal calculation of the validation (VAL) and colour burst blanking (CBB) signals, if programmed
- Programmable framing code and channel numbers
- Error parity calculation or not (odd parity)
- Hamming processing of the prefix byte
- Full channel or VBI reception
- Slow/fast mode (detection of page flags or not)
- Maximum/default format up to 63 bytes
- Addressing space of 2 K bytes of the static memory
- Multiplexed address/data information is compatible with Motorola or Intel microcontrollers
- CIDAC is 'MOTEL' compatible

**PACKAGE OUTLINES**

SAA5250P: 40-lead DIL; plastic (SOT-129).

SAA5250T: 40-lead mini-pack; plastic (VSO-40; SOT-158A).

Interface for data acquisition and control  
(for multi-standard teletext systems)

SAA5250

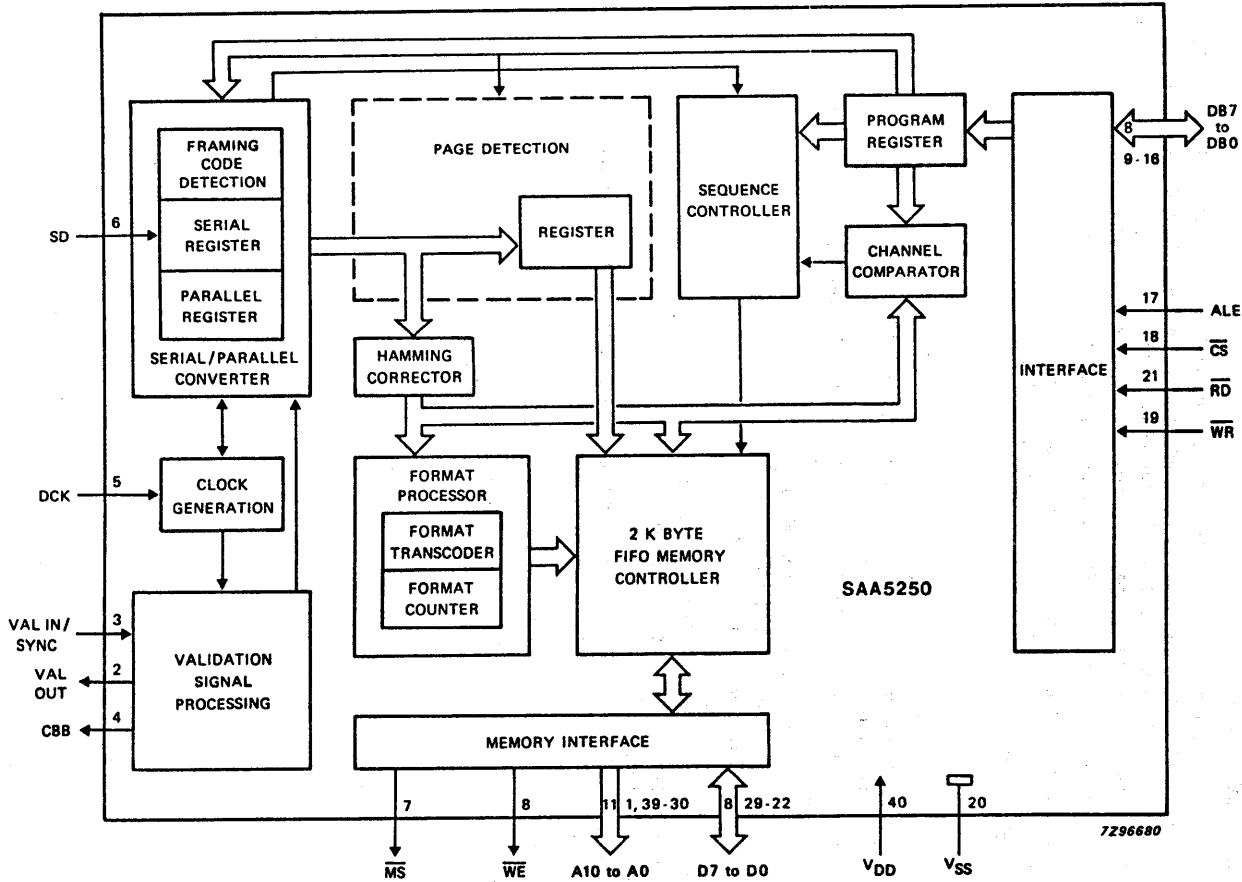

Fig. 1 Block diagram.

Interface for data acquisition and control  
(for multi-standard teletext systems)

SAA5250

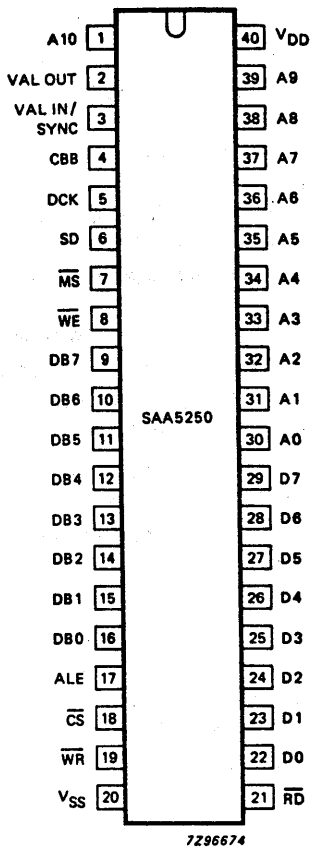

Fig. 2 Pinning diagram.

# Interface for data acquisition and control (for multi-standard teletext systems)

SAA5250

## PINNING FUNCTION

mnemonic	pin no.	function
A10 and A0 to A9	1 and 30 to 39	Memory address outputs used by CIDAC to address a 2 K byte buffer memory
VAL OUT	2	Validation output signal used to control the location of the window for the framing code
VAL IN/SYNC	3	Validation input signal (line signal) used to give or calculate a window for the framing code detection
CBB	4	Colour burst blanking output signal used by the SAA5230 as a data slicer reset pulse
DCK	5	Data clock input, in synchronization with the serial data signal
SD	6	Serial data input, arriving from the demodulator
$\overline{MS}$	7	Chip enable output signal for buffer memory selection
$\overline{WE}$	8	Write command output for the buffer memory
DB7 to DB0	9 to 16	8-bit three state input/output data/address bus used to transfer commands, data and status between the CIDAC registers and the CPU
ALE	17	Demultiplexing input signal for the CPU data bus
$\overline{CE}$	18	Chip enable input for the SAA5250
$\overline{WR}$	19	Write command input (when LOW)
VSS	20	ground
$\overline{RD}$	21	Read command input (when LOW)
D0 to D7	22 to 29	8-bit three state input/output data bus used to transfer data between CIDAC and the buffer memory
VDD	40	+5 V power supply

Interface for data acquisition and control  
(for multi-standard teletext systems)

SAA5250

**FUNCTIONAL DESCRIPTION**

**Microcontroller interface**

The microcontroller interface communicates with the CPU via the handshake signals DB7 – DB0, ALE, CS,  $\overline{RD}$ ,  $\overline{WR}$ . The microcontroller interface produces control commands as well as programming the registers to write their contents or read incoming status/data information from the buffer memory. The details of the codes used to address the registers are given in Table 2.

The CIDAC is 'MOTEL' compatible (MOTEL compatible means it is compatible with standard Motorola or Intel microcontrollers). It automatically recognizes the microcontroller type (such as the 6801 or 8501) by using the ALE signal to latch the state of the  $\overline{RD}$  input. No external logic is required.

Table 1 Recognition signals

CIDAC	8049/8051 timing 1	6801/6805 timing 2
$\overline{ALE}$ $\overline{RD}$ $\overline{WR}$	$\overline{ALE}$ $\overline{RD}$ $\overline{WR}$	AS DS, E, $\Phi$ 2 R/W

DEVELOPMENT DATA

Table 2 CIDAC register addressing

codes						function
R	W	CS	DB2	DB1	DB0	
1	0	0	0	0	0	write register R0
1	0	0	0	0	1	write register R1
1	0	0	0	1	0	write register R2
1	0	0	0	1	1	write register R3
1	0	0	1	0	0	write register R4
1	0	0	1	0	1	write register R5
1	0	0	1	1	0	write command register R6 (initialization command)
1	0	0	1	1	1	write register R7
0	1	0	0	0	0	read status
0	1	0	0	0	1	read data register
0	1	0	0	1	0	test (not used)
0	1	0	0	1	1	test (not used)

# Interface for data acquisition and control (for multi-standard teletext systems)

SAA5250

## Register organization

### R0 register

Table 3 R0 Register contents

R04 slow/fast mode	R03 parity	R02 to R00 used prefixes
0 = slow mode 1 = fast mode	0 = no parity control 1 = odd parity	000 = DIDON long 001 = DIDON medium 010 = DIDON short 011 = not used 100 = U.K. teletext 101 = NABTS 110 } without prefix 111 }

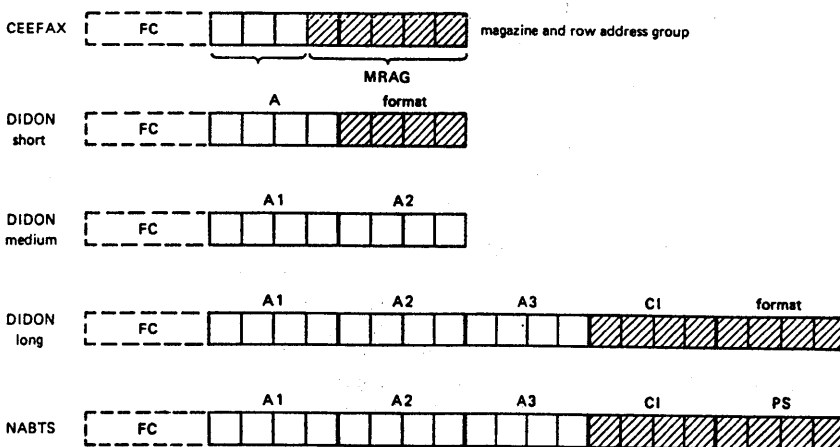

Fig. 3 Five prefixes.

7296676

All of the bytes (see Fig. 3) are Hamming protected. The hatched bytes are always stored in the memory in order to be processed by the CPU (see section 'Prefix processing'). In the mode without prefix all of the bytes which follow the framing code are stored in the memory until the end of the data packet, the format is then determined by the contents of the R3 register.

If R03 = 0; no parity control is carried out and the 8-bits of the incoming data bytes are stored in the fifo memory.

If R03 = 1; the 8th bit of the bytes following the prefix (data bytes) represents the result of the odd parity control.

If R04 = 0; the device operates in the slow mode. The CIDAC retrieves data from the user selected magazine (see section 'R1 and R2') and without searching for a start to a page stores the data into the FIFO memory.

Interface for data acquisition and control  
(for multi-standard teletext systems)

SAA5250

If R04 = 1; the device operates in the fast mode. Prior to writing into the FIFO memory, the CIDAC searches for a start to a page which is variable due to the different prefixes:

- DIDON (long, medium and short): using the redundant bytes, SOH RS, X RS and SOH X (where X is a bit affected by a parity error)
- NABTS, the least significant bit of the PS byte is set to 1
- U.K. teletext, ROW = 0

R1 register

Table 4 R1 Register contents

R17 VAL IN/SYNC	R16 to R14 format table	R13 to R10 channel numbers (first digit)
1 = VAL 0 = SYNC	000 = list 1 001 = list 2 010 = list 3 011 = list 4 1XX = maximum/default value used (R3)	first digit hexadecimal value

DEVELOPMENT DATA

Note

X = don't care

If VAL IN/SYNC = 1; the line signal immediately produces a validation signal for the framing code detection.

If VAL OUT = 0; the line signal is used as a starting signal for an internally processed validation signal (see Fig. 15). The framing code window width is fixed at 13 clock periods and the delay is determined by the contents of the R5 register (R56 to R50).

At any moment the user is able to ensure that the framing code window is correctly located. This is accomplished by the VAL OUT pin reflecting the internal validation signal. A CBB signal with programmable width (see section 'R7 register') can also be generated, this is used as a data slicer reset pulse by the SAA5230. The line signal is used as the starting point of the internal CBB signal width fixed by the contents of the R7 register.

If R16 = 0; then bits R15 and R14 provide the format table number using DIDON long and short prefixes (see Table 6).

If R16 = 1; then the format is determined by the contents of the R3 register.

The bits R13 to R10 represent the first channel number to be checked in the prefix. In U.K. teletext mode only 3 bits are required, so R13 = X.

**Interface for data acquisition and control  
(for multi-standard teletext systems)**

**SAA5250**

**Table 5 Format table**

format byte B8, B6, B4 and B2	list 1	list 2	list 3	list 4
0000	0	0	0	0
0001	1	1	1	1
0010	2	2	2	2
0011	3	3	3	3
0100	4	5	6	7
0101	8	9	10	11
0110	12	13	14	15
0111	16	17	18	19
1000	20	21	22	23
1001	24	25	26	27
1010	28	29	30	31
1011	32	33	34	35
1100	36	37	38	39
1101	40	41	42	43
1110	44	45	46	47
1111	48	49	50	51

**Note**

B8 = MSB and B2 = LSB.

*R2 register*

**Table 6 R2 Register contents**

R27 to R24	R23 to R20
channel number, third digit	channel number, second digit
(hexadecimal value, third digit)	(hexadecimal value, second digit)

**Note**

R27 and R23 = MSB and R24 and R20 = LSB

The R2 register provides the other two parts of the channel number (depending on the prefix) that require checking.



Interface for data acquisition and control  
(for multi-standard teletext systems)

SAA5250

*R3 register*

**Table 7** R3 register contents

R35 to R30 6-bit format maximum/default value
000000 = 0
000001 = 1
-
-
-
111111 = 63

This 6-bit byte gives:

- In the DIDON long and short mode, a maximum format in case of corrupted transmission (multiple errors on the Hamming corrector)
- A possible 63-bit format for all types of prefix

*R4 register*

**Table 8** R4 register contents

R47 to R40
8-bit register used for storing the framing code value which will be compared with the third byte of each data line

DEVELOPMENT DATA

*R5 register*

**Table 9** R5 register contents

R57 negative/positive	R56 to R50 synchronization delay
0 = negative edge for sync signal 1 = positive edge for sync signal	7-bit sync delay, giving a maximum delay of $(2^7 - 1) \times 10^6 \mu\text{s}/F$ (Hz)

**Note**

F = data clock acquisition frequency (DCK).

Using R57 it is possible to start the internal synchronization delay ( $t_{DVAL}$ ) on the positive or negative edge.

# Interface for data acquisition and control (for multi-standard teletext systems)

SAA5250

## R6 write command register

This is a fictitious register. Only the address code (see Table 2) is required to reset the CIDAC. See Table 11 for the status of the FIFO memory on receipt of this command.

## R7 register

Table 10 R7 register contents

R75 to R70
6-bit register used to give a maximum colour burst blanking signal of: $(2^6 - 1) \times 10^6 \mu\text{s}/F$ (Hz)

## Note

F = data clock acquisition frequency.

## Fifo status register (read R0 register)

Table 11 Fifo register contents

DB2 to DB0		
DB2 = 1 memory empty	DB1 = 1, data not present in the read data register	DB0 = 0 memory not full

Once the relevant prefix and the right working modes have been given by the corresponding registers, a write command to the R6 register enables the CIDAC to accept and process serial data.

## Channel comparator

This is a four bit comparator which compares the three user hexadecimal defined values in R1 and R2 to the corresponding bytes of the prefix coming from the Hamming corrector. If the three bytes match, the internal process of the prefix continues. If they do not match the CIDAC returns to a wait state until the next broadcast data package is received.

## FIFO memory controller

The FIFO memory contains all the necessary functions required for the control of the 11-bit address memory (2 K byte). The functions contained in the FIFO memory are as follows:

- write address register (11-bits)
- read address register (11-bits)
- memory pointer (11-bits)
- address multiplexer (11-bits)
- write data register (8-bits)
- read data register (8-bits)
- data multiplexer
- control logic

The FIFO memory provides the memory interface with the following:

- 11-bit address bus (A10 to A0)
- 8-bit data bus (D7 to D0)
- two control signals, memory select ( $\overline{MS}$ ) and write enable ( $\overline{WE}$ )

# Interface for data acquisition and control (for multi-standard teletext systems)

SAA5250

## Operation

The CIDAC uses the same clock signal for data acquisition and internal processing, this allows the CIDAC to have a write and a read cycle during each character period (see Fig. 13). The first half of the character period is a write cycle and the second half is a read cycle. Consequently, for an 8 MHz bit rate the maximum memory cycle time is 500 ns.

When the first data byte is written into the FIFO memory, thus transferred into the read register, the FIFO memory enters the status shown in Table 12.

**Table 12** FIFO status

DB2 to DB0		
DB2 = 1 memory empty	DB1 = 0 data available	DB0 = 0 memory not full

When the FIFO memory is full two events occur:

- the write address register points to the next address after the last written address
- when new data is to be written, the memory select signal output ceases

**DEVELOPMENT DATA**

## Memory interface

The memory interface contains all the buffers for the memory signals mentioned in the section 'FIFO memory controller'.

## Page detection

This part of the CIDAC contains a parallel register with logic which detects (only in fast mode) a start of a page or data group (see section 'RO register').

## Hamming correction (see Tables 13 and 14)

The Hamming correction provides (see section 'Prefix processing'):

- hexadecimal value of the Hamming code
- accept/reject code signal
- parity information

Interface for data acquisition and control  
(for multi-standard teletext systems)

SAA5250

Table 13 Hamming correction (coding)

Hexadecimal notation	B8	B7	B6	B5	B4	B3	B2	B1
0	0	0	0	1	0	1	0	1
1	0	0	0	0	0	0	1	0
2	0	1	0	0	1	0	0	1
3	0	1	0	1	1	1	1	0
4	0	1	1	0	0	1	0	0
5	0	1	1	1	0	0	1	1
6	0	0	1	1	1	0	0	0
7	0	0	1	0	1	1	1	1
8	1	1	0	1	0	0	0	0
9	1	1	0	0	0	1	1	1
A	1	0	0	0	1	1	0	0
B	1	0	0	1	1	0	1	1
C	1	0	1	0	0	0	0	1
D	1	0	1	1	0	1	1	0
E	1	1	1	1	1	1	0	1
F	1	1	1	0	1	0	1	0

Note

$B7 = B8 \oplus B6 \oplus B4$

$B5 = B6 \oplus B4 \oplus B2$

$B3 = B4 \oplus B2 \oplus B8$

$B1 = B2 \oplus B8 \oplus B6$

$\oplus$  = exclusive OR gate function

B8, B6, B4 and B2 = data bits

B7, B5, B3 and B1 = redundancy bits

Table 14 Hamming correction (decoding)

A	B	C	D	interpretation	information
1	1	1	1	no error	accepted
0	0	1	0	error on B8	corrected
1	1	1	0	error on B7	accepted
0	1	0	0	error on B6	corrected
1	1	0	0	error on B5	accepted
1	0	0	0	error on B4	corrected
1	0	1	0	error on B3	accepted
0	0	0	0	error on B2	corrected
0	1	1	0	error on B1	accepted
A.B.C = 0			1	multiple errors	rejected

Note

$A = B8 \oplus B6 \oplus B2 \oplus B1$

$B = B8 \oplus B4 \oplus B3 \oplus B2$

$C = B6 \oplus B5 \oplus B4 \oplus B2$

$D = B8 \oplus B7 \oplus B6 \oplus B5 \oplus B4 \oplus B3 \oplus B2 \oplus B1$

# Interface for data acquisition and control (for multi-standard teletext systems)

SAA5250

## Format processing

The format processing consists of two parts:

### part 1

A format transcoder produces a 6-bit code (up to 63) and uses the following as inputs:

- DIDON long and short prefixes;
  - hamming corrected code (4-bits)
  - accept/reject code condition
  - table number (see section 'R1 register', bits R15 and R14)
- Other prefixes (R16 = 1)
- 6-bit maximum/default format (see section 'R3 register')

### part 2

A format counter operating at the character clock frequency which receives the 6-bit code from the format transcoder and is used to check the data packet length following the prefix.

## Serial/parallel converter

The serial/parallel converter consists of three parts:

- An 8-bit shift register which receives the SD input and operates at the bit frequency (DCK).
- An 8-bit parallel register used for storage.
- A framing code detection circuit. This logic circuit compares the 8-bits of the R4 register with that of the serial register. If seven bits out of eight match (in coincidence with a validation window), it produces a start signal for a new teletext data line to the sequence controller.

## Clock generation

The clock generator does the following:

- acts as a buffer for the DCK clock
- generates the character clock

As soon as a framing code has been detected, a divide by 8 counter is initialized and the character clock is started. The clock drives the following:

- sequence controller
- parallel registers
- format counter

DEVELOPMENT DATA

# Interface for data acquisition and control (for multi-standard teletext systems)

SAA5250

### Processing of VAL and CBB signals

The circuit has one input (VAL IN/SYNC) and two outputs (VAL OUT and CBB). The circuit consists of:

- 7-bit counter operating at DCK frequency which produces the framing code validation pulse delay
- 7-bit comparator which compares the contents of the R5 register (bits R56 to R50) to the bit counter
- a 6-bit counter operating at DCK frequency which produces the CBB pulse width
- 6-bit comparator which compares the contents of the R7 register (bits R75 to R70) to the bit counter
- control logic required to provide the start condition for the VAL signal and the CBB pulse width (on the negative or positive edge of the sync signal)

The CBB signal usefulness occurs when the associated video processor:

- has no sandcastle pulse to send back to the demodulator
- carries out the synchronization of the time base clock. In this event the CBB acts as a data slicer reset pulse

The VAL OUT is a control signal which reflects the internal framing code window.

### Prefix processing (see Table 21)

Figs 4 to 9 show the acquisition flow charts for each prefix type coded in the R0 register (bits R02 to R00).

As soon as an initialization command is received by the CIDAC, a write command to the R6 register (only the address is significant), is ready to receive data from a dedicated channel number and store the data in the FIFO memory (explained in the following paragraphs, each paragraph being dedicated to an individual type of prefix).

### DIDON long (see Fig. 4)

In this mode, the continuity index, format and data bytes are written into the FIFO memory. (In fast mode, information can be written into the FIFO memory only after a page detection.)

Table 15 Continuity index processing result

D7	D6	D5	D4	D3	D2	D1	D0
A/R	X	X	X	C13	C12	C11	C10

Table 16 Format processing result

D7	D6	D5	D4	D3	D2	D1	D0
A/R	X	F5	F4	F3	F2	F1	F0

### Note

- A/R = 0, if rejected
- A/R = 1, if accepted
- X = don't care

# Interface for data acquisition and control (for multi-standard teletext systems)

SAA5250

**DIDON medium (see Fig. 5)**

Only data bytes are written into the FIFO memory. (In fast mode, information can be written into the FIFO memory only after a page detection.)

**DIDON short (see Fig. 6)**

In this mode, format and data bytes are written into the FIFO memory. (In fast mode, information can be written into the FIFO memory only after a page detection.)

**Table 17** Format processing result

D7	D6	D5	D4	D3	D2	D1	D0
A/R	X	F5	F4	F3	F2	F1	F0

**NABTS (see Fig. 7)**

In this mode, the continuity index, packet structure and data bytes are written into the FIFO memory. (In fast mode, information can be written into the FIFO memory only after a page detection.)

**Table 18** Continuity index processing result

D7	D6	D5	D4	D3	D2	D1	D0
A/R	X	X	X	CI3	CI2	CI1	CI0

**Table 19** Packet structure processing result

D7	D6	D5	D4	D3	D2	D1	D0
A/R	X	X	X	PS3	PS2	PS1	PS0

**U.K. teletext (see Fig. 8)**

In this mode, the magazine and row address group (two bytes) and data bytes are written into the FIFO memory. (In fast mode, information can be written into the FIFO memory only after a flag detection.)

**Table 20** Magazine and row address group processing results

D7	D6	D5	D4	D3	D2	D1	D0
A/R	X	X	RW4	RW3	RW2	RW1	RW0

**Without prefix**

All the data following the framing code are stored in the FIFO memory.

DEVELOPMENT DATA

# Interface for data acquisition and control (for multi-standard teletext systems)

SAA5250

**Table 21** Prefix processing

prefixes	construction of prefixes	bytes stored in FIFO memory during slow mode	bytes stored in FIFO memory during fast mode
DIDON long	A1, A2, A3, CI, F and D	CI, F and D	CI*, F* and D*
DIDON medium	A1, A2 and D	D	D*
DIDON short	A1, F and D	F and D	F* and D*
NABTS	A1, A2, A3 CI, PS and D	CI, PS and D	CI*, PS* and D*
U.K. teletext	MRAG and D	MRAG and D	MRAG* and D*
without prefix		all bytes of the data packet following the framing code are written into the FIFO memory	

**Note**

\* = after page/flag detection

A1, A2, A3 are channel numbers

CI = continuity index

F = format

PS = packet structure

D = data

MRAG = magazine and row address group



Interface for data acquisition and control  
(for multi-standard teletext systems)

SAA5250

DEVELOPMENT DATA

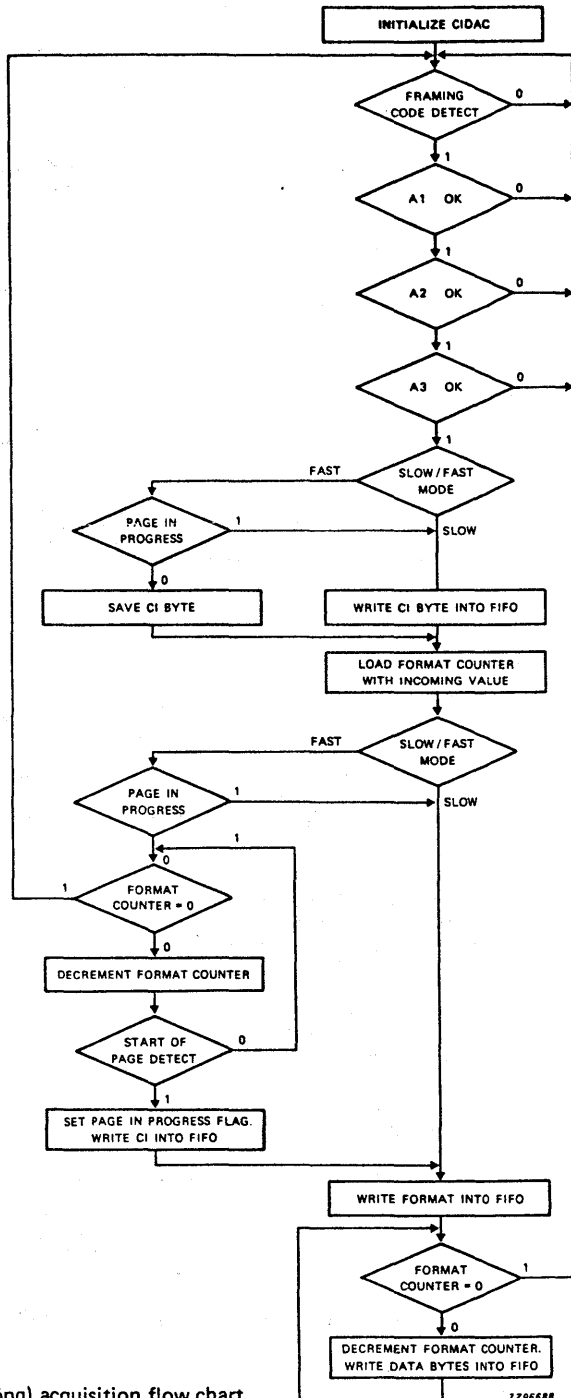

Fig. 4 DIDON (long) acquisition flow chart.

7296688

# Interface for data acquisition and control (for multi-standard teletext systems)

SAA5250

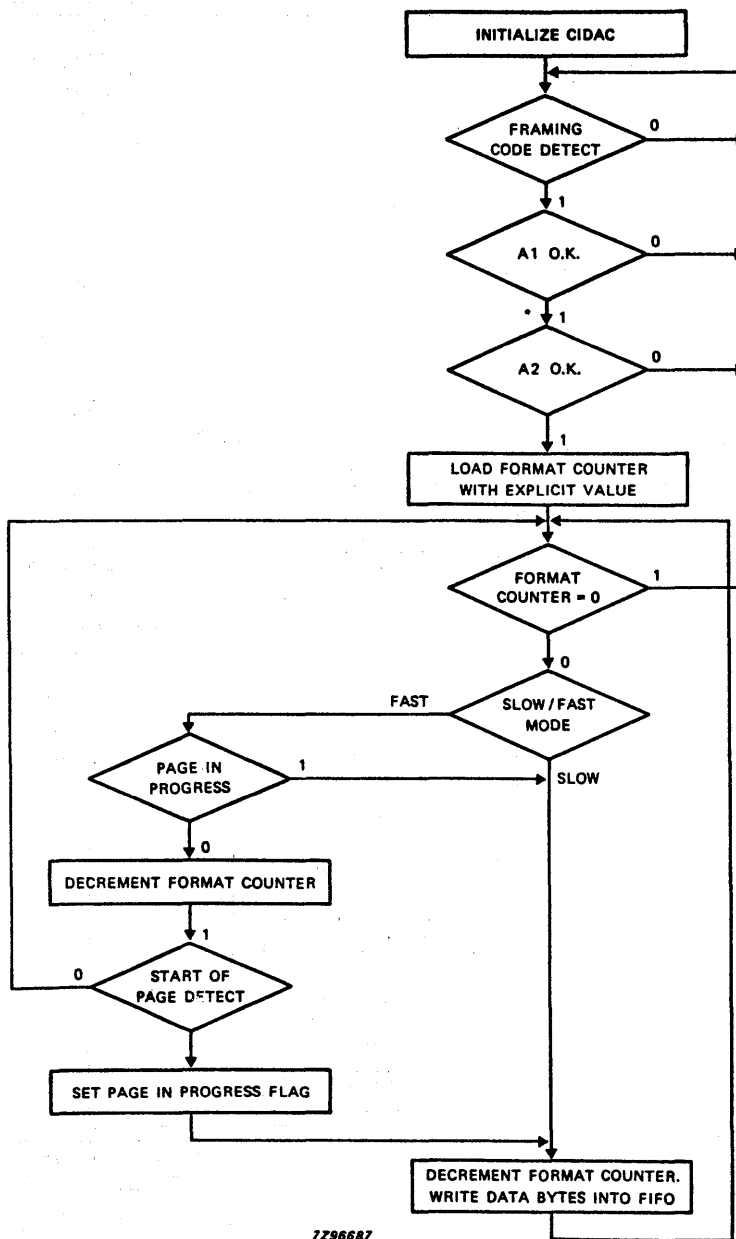
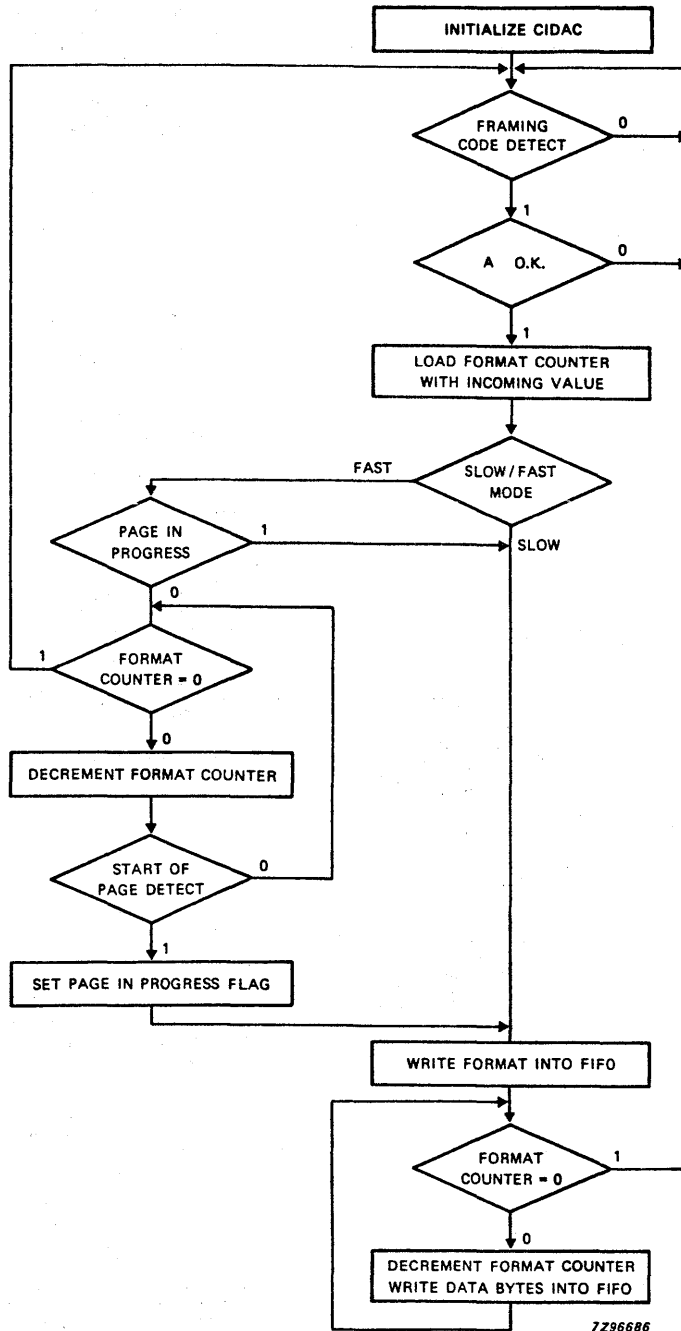

Fig. 5 DIDON (medium) acquisition flow chart.

# Interface for data acquisition and control (for multi-standard teletext systems)

SAA5250

DEVELOPMENT DATA



7296686

Fig. 6 DIDON (short) acquisition flow chart.

Interface for data acquisition and control  
(for multi-standard teletext systems)

SAA5250

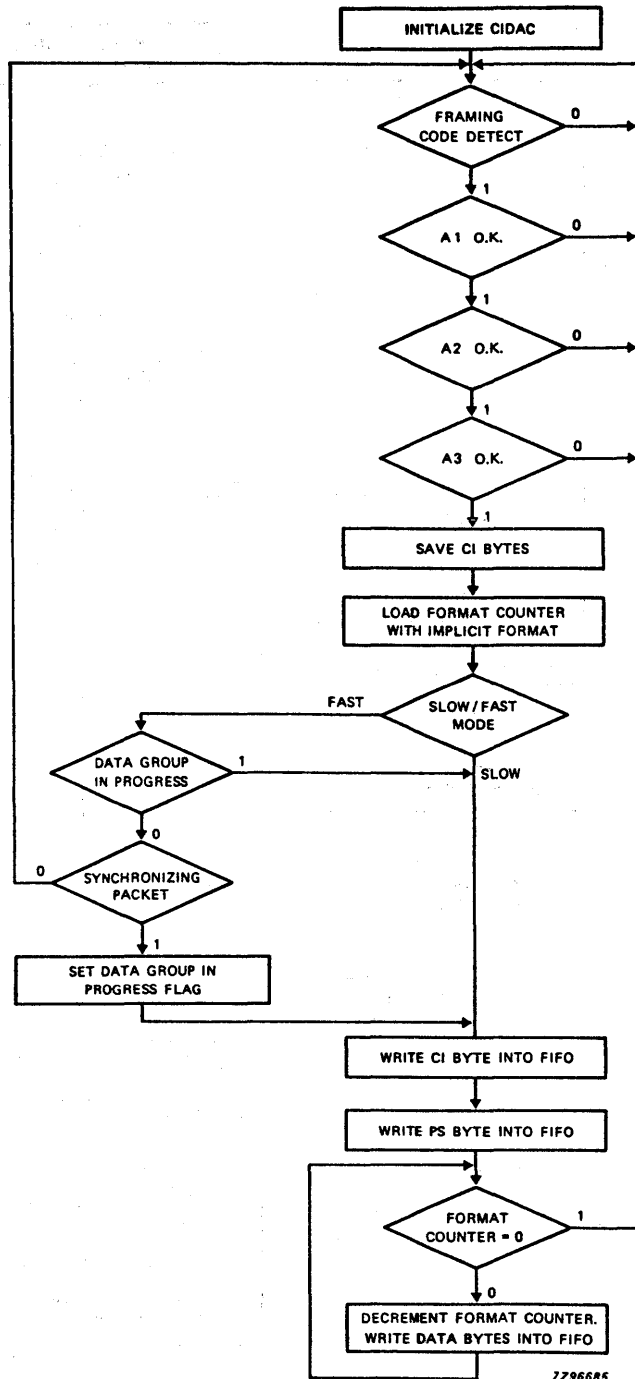

7296685

Fig. 7 NABTS acquisition flow chart.

# Interface for data acquisition and control (for multi-standard teletext systems)

SAA5250

DEVELOPMENT DATA

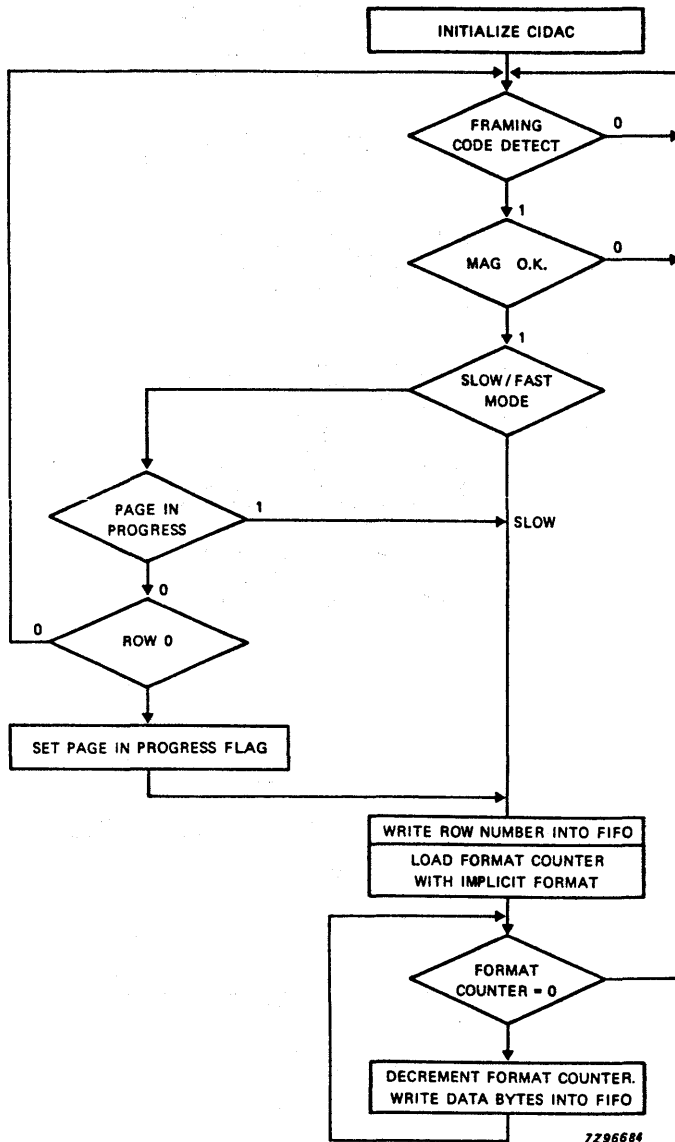

7296684

Fig. 8 U.K. teletext acquisition flow chart.

Interface for data acquisition and control  
(for multi-standard teletext systems)

SAA5250

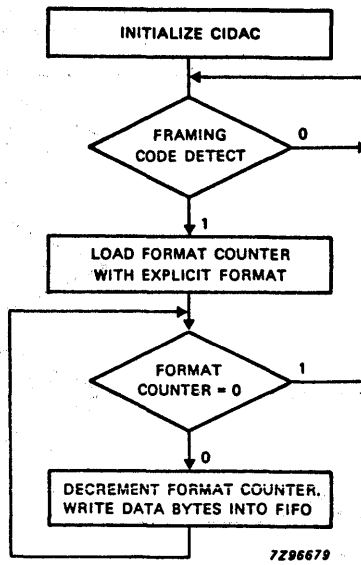

Fig. 9 Without prefix acquisition chart.

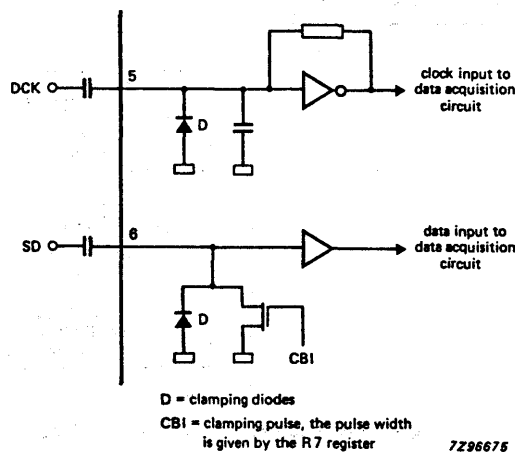

Fig. 10 SD and DCK input circuitry.

# Interface for data acquisition and control (for multi-standard teletext systems)

SAA5250

**RATINGS**

Limiting values in accordance with the Absolute Maximum System (IEC 134)

parameter	conditions	symbol	min.	max.	unit
Supply voltage range		$V_{DD}$	-0,3	6,5	V
Input voltage range		$V_I$	-0,3	$V_{DD}+0,3$	V
Total power dissipation		$P_{tot}$	—	400	mW
Operating ambient temperature range		$T_{amb}$	0	70	°C
Storage temperature range		$T_{stg}$	-20	+125	°C

**D.C. CHARACTERISTICS** (except SD and DCK) $V_{DD} = 5\text{ V} \pm 10\%$ ;  $V_{SS} = 0\text{ V}$ ;  $T_{amb} = 0\text{ to }70\text{ }^\circ\text{C}$ , unless otherwise specified

DEVELOPMENT DATA

parameter	conditions	symbol	min.	typ.	max.	unit
Supply voltage range		$V_{DD}$	4,5	5,0	5,5	V
Input voltage HIGH		$V_{IH}$	2	—	$V_{DD}$	V
Input voltage LOW		$V_{IL}$	—	—	0,8	V
Input leakage current		$I_I$	—	—	1,0	$\mu\text{A}$
Output voltage HIGH	$I_{load} = 1\text{ mA}$	$V_{OH}$	$V_{DD}-0,4$	—	—	V
Output voltage LOW	$I_{load} = 4\text{ mA}$ , at pins 9 to 16 and 22 to 29	$V_{OL}$	—	—	0,4	V
	$I_{load} = 1\text{ mA}$ all other outputs	$V_{OL}$	—	—	0,4	V
Power dissipation		$P$	—	5	—	mW
Input capacitance		$C_I$	—	—	7,5	pF

# Interface for data acquisition and control (for multi-standard teletext systems)

SAA5250

**SD and DCK D.C. CHARACTERISTICS (see Fig. 10)** $V_{DD} = 5\text{ V}$ ;  $V_{SS} = 0\text{ V}$ ;  $T_{amb} = 0\text{ to }70\text{ }^{\circ}\text{C}$ , unless otherwise specified

parameter	conditions	symbol	min.	typ.	max.	unit
<b>DCK</b>						
Input voltage range (peak-to-peak value)	$V_I = 0\text{ to }V_{DD}$	$V_{I(p-p)}$	2,0	—	—	V
Input current		$I_I$	5	—	200	$\mu\text{A}$
Input capacitance		$C_I$	—	—	30	pF
External coupling capacitor		$C_{ext}$	10	—	—	nF
<b>SD</b>						
D.C. input voltage range HIGH	note 1	$V_{IH}$	2,0	—	—	V
D.C. input voltage range LOW	note 2	$V_{IL}$	—	—	0,8	V
A.C. input voltage (peak-to-peak value)	$V_I = 0\text{ to }V_{DD}$	$V_{I(p-p)}$	2,0	—	—	V
Input leakage current		$I_I$	—	—	10	$\mu\text{A}$
Input capacitance		$C_I$	—	—	30	pF
External coupling capacitor		$C_{ext}$	10	—	—	nF



Interface for data acquisition and control  
(for multi-standard teletext systems)

SAA5250

**A.C. CHARACTERISTICS**

$V_{DD} = 5\text{ V} \pm 10\%$ ; Reference levels for all inputs and outputs,  $V_{IH} = 2\text{ V}$ ;  $V_{IL} = 0,8\text{ V}$ ;  $V_{OH} = 2,4\text{ V}$ ;  $V_{OL} = 0,4\text{ V}$ ;  $C_L = 50\text{ pF}$  on DB7 to DB0;  $T_{amb} = 0\text{ to }70\text{ }^\circ\text{C}$ , unless otherwise specified

DEVELOPMENT DATA

parameter	conditions	symbol	min.	typ.	max.	unit
<b>Microcontroller interface</b>	<b>Figs 11 and 12</b>					
Cycle time		$t_{CY}$	400	—	—	ns
Address pulse width		$t_{LHLL}$	50	—	—	ns
$\overline{RD}$ HIGH or $\overline{WR}$ to ALE HIGH	Fig. 11	$t_{AHRD}$	0	—	—	ns
DS LOW to AS HIGH	Fig. 12	$t_{AHRD}$	0	—	—	ns
ALE LOW to $\overline{RD}$ LOW or $\overline{WR}$ LOW	Fig. 11	$t_{ALRD}$	30	—	—	ns
AS LOW to DS HIGH	Fig. 12	$t_{ALRD}$	30	—	—	ns
Write pulse width		$t_{WL}$	120	—	—	ns
Address and chip select set-up time		$t_{ASL}$	10	—	—	ns
Address and chip select hold time		$t_{AHL}$	20	—	—	ns
Read to data out period		$t_{RD}$	—	—	130	ns
Data hold after $\overline{RD}$		$t_{DR}$	10	—	100	ns
$R/\overline{W}$ to DS set-up time	Fig. 12	$t_{RWS}$	40	—	—	ns
$R/\overline{W}$ to DS hold time	Fig. 12	$t_{RWH}$	10	—	—	ns
Data set-up time	write cycle	$t_{DW}$	50	—	—	ns
Data hold time	write cycle	$t_{WD}$	10	—	—	ns
Read pulse width	note 3	$t_{RL}$	150 or DCK + 50	—	—	ns

Interface for data acquisition and control  
(for multi-standard teletext systems)

SAA5250

parameter	conditions	symbol	min.	typ.	max.	unit
<b>Memory interface</b>						
Fig. 13						
$\overline{WE}$ LOW to DCK falling edge		tWEL	10	—	80	ns
$\overline{WE}$ HIGH to DCK falling edge		tWEH	10	—	80	ns
$\overline{MS}$ LOW to DCK rising edge		tMSL	10	—	80	ns
$\overline{MS}$ HIGH to DCK rising edge		tMSH	10	—	85	ns
Address output from DCK rising edge		tAV	10	—	120	ns
Data output from $\overline{WE}$ falling edge		tDWL	0	—	10	ns
Data hold from $\overline{WE}$ rising edge		tDWH	0	—	—	ns
Address set-up time to data	note 4	tAD	—	—	3 x DCK — 110	ns
$\overline{WE}$ pulse width	note 5	tWEW	3 x DCK	—	—	ns
$\overline{MS}$ pulse width	note 6	tMSW	2 x DCK	—	—	ns
<b>Demodulator interface</b> (see SD and DCK D.C. CHARACTERISTICS)						
Fig. 14						
DCK LOW	conversion rate < 7,5 MHz	tDCKL	55	—	—	ns
DCK HIGH	conversion rate < 7,5 MHz	tDCKH	55	—	—	ns
Serial data set-up time		tSSD	0	—	—	ns
Serial data hold time		tHSD	30	—	—	ns
Validation signal set-up time		tSVALI	50	—	—	ns
Validation signal hold time		tHVALI	50	—	—	ns
<b>Other I/O signals</b>						
Fig. 15						
User definable width as a multiple of DCK period		tWCBB	0	—	63	DCK
Validation signal width	note 7	tWVAL	X	12	X	DCK
User definable delay as a multiple of DCK period		tDVAL	0	—	127	DCK

---

**Interface for data acquisition and control**  
**(for multi-standard teletext systems)**

---

**SAA5250****Notes to the characteristics**

1. Unless R7 = 00 the value given is unacceptable.
2. When CBI signal is maintained at 0 V (R7 = 00) and if SD input signal is correctly referenced to ground, no coupling capacitor is required.
3. DCK + 50 is the DCK period plus 50 ns.
4. 3 x DCK - 110 is 3 x DCK period - 110 ns.
5. 3 x DCK is 3 x DCK period.
6. 2 x DCK is 2 x DCK period.
7. X = irrelevant.

**DEVELOPMENT DATA**

Interface for data acquisition and control  
(for multi-standard teletext systems)

SAA5250

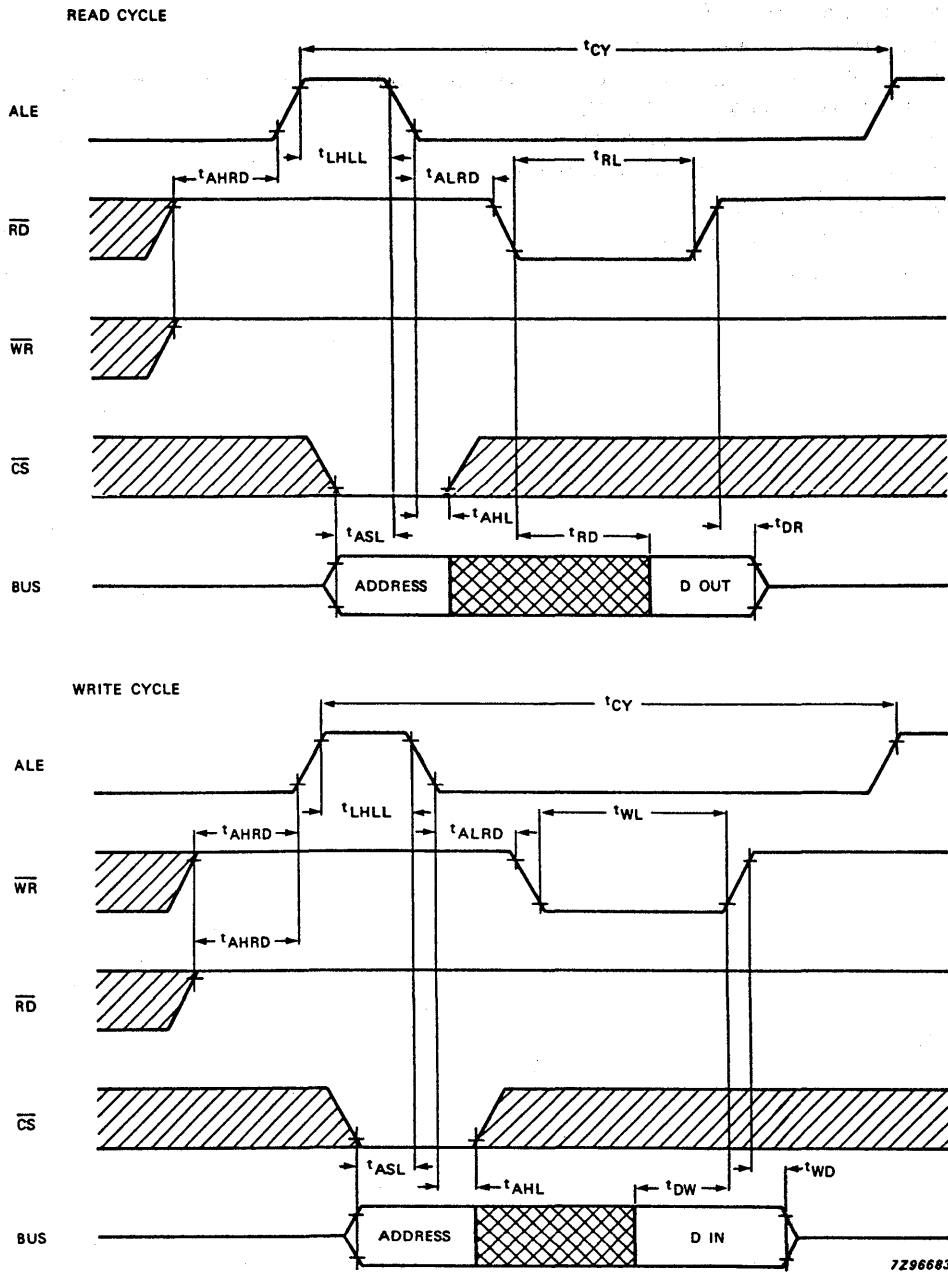

7296683

Fig. 11 Timing diagram for microcontroller interface (Intel).

Interface for data acquisition and control  
(for multi-standard teletext systems)

SAA5250

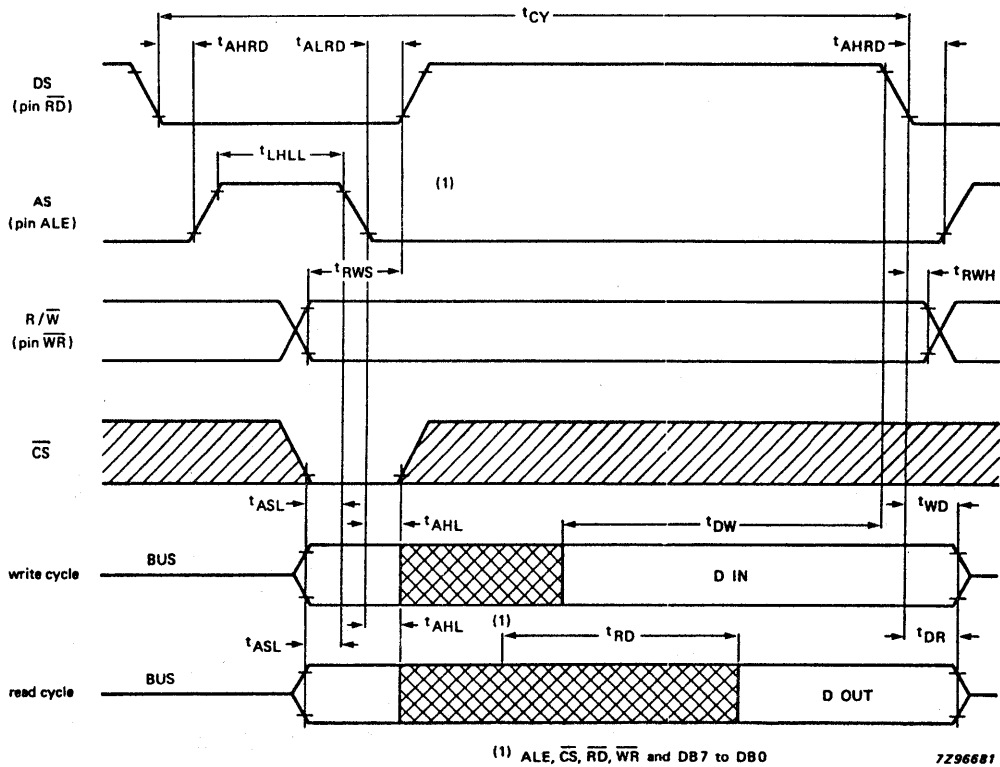

Fig. 12 Timing diagram for microcontroller interface (Motorola).

Interface for data acquisition and control  
(for multi-standard teletext systems)

SAA5250

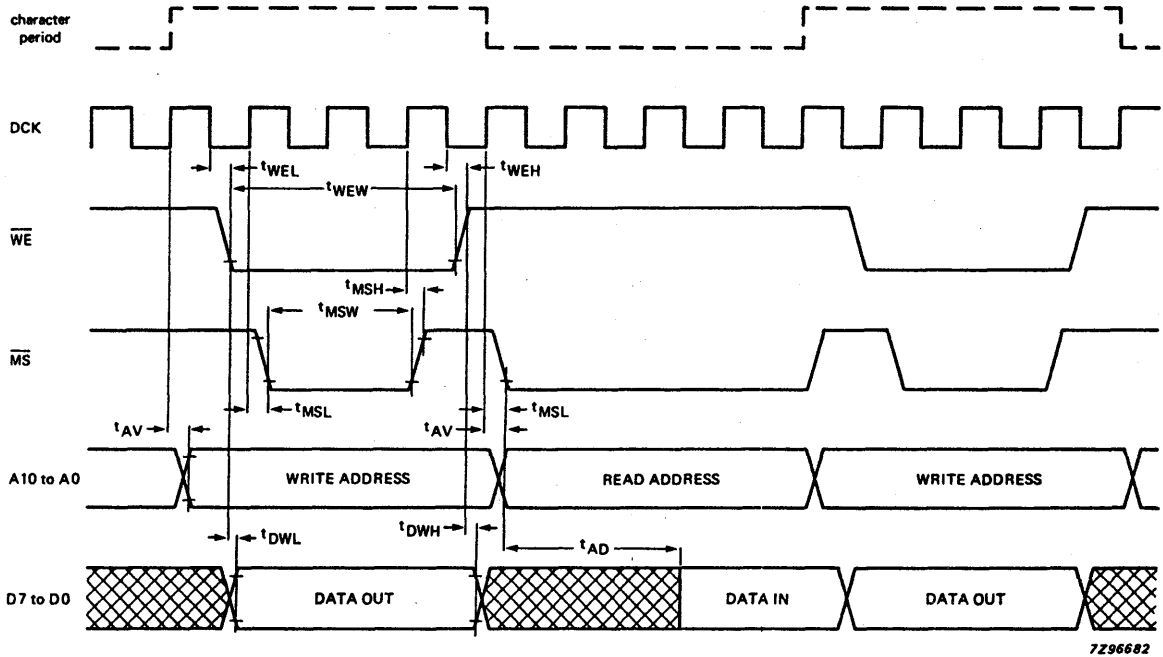

Fig. 13 Timing diagram for memory interface.

Interface for data acquisition and control  
(for multi-standard teletext systems)

SAA5250

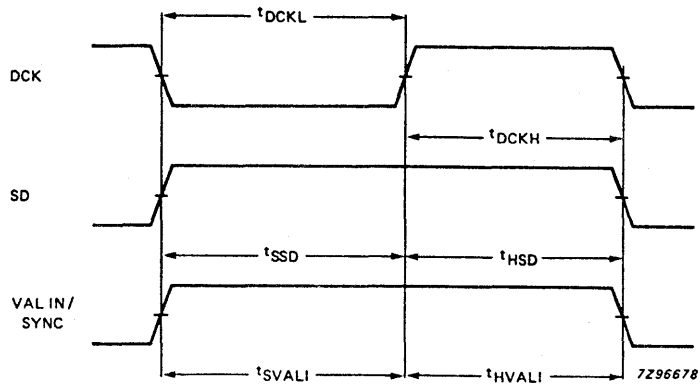

Fig. 14 Timing diagram for demodulator interface.

DEVELOPMENT DATA

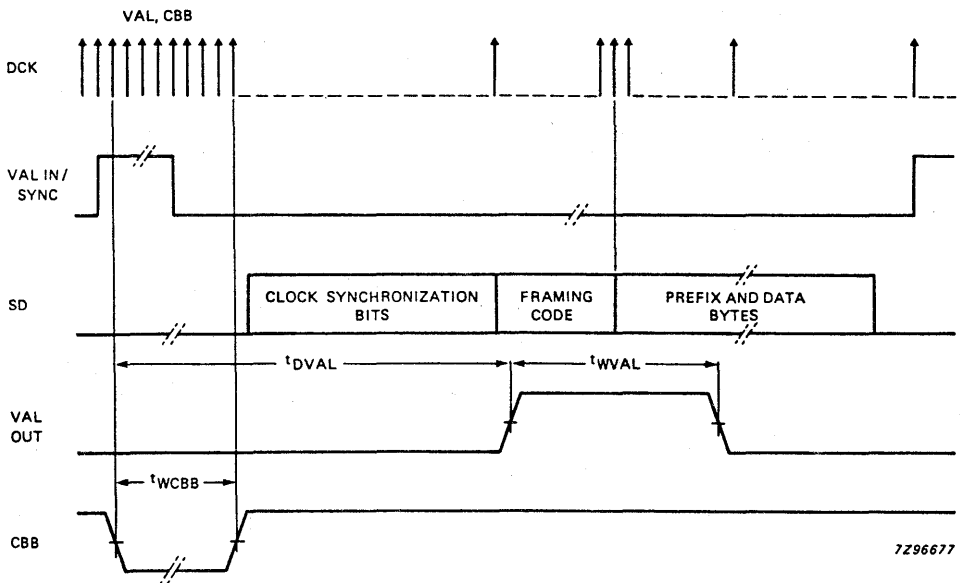

Fig. 15 Timing diagram for all other I/O signals.

# Line twenty-one acquisition and display (LITOD)

SAA5252

## FEATURES

- Complete 'stand-alone' Line 21 decoder in one package
- On-chip display RAM allowing full page Text mode
- Enhanced character display modes
- Full colour captions
- RGB interface for standard colour decoder ICs
- Automatic handling of Field 2 data
- Automatic selection of (1H, 1V), (2H, 1V) or (2H, 2V) scan modes
- Onboard OSD facility using Character generator
- RGB inputs to support existing OSD ICs
- I<sup>2</sup>C-bus or 'stand-alone' pin control
- Automatic data-ready signal generation on data acquisition
- Can decode signals recorded on standard VHS and S-VHS tape.

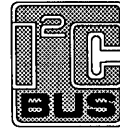

## GENERAL DESCRIPTION

The SAA5252 (LITOD) is a single-chip CMOS device, which will acquire, decode and display Line 21 Closed Captioning data from a 525-line composite video signal. Operation as an On-Screen Display (OSD) device is also possible. Normal and line progressive scan modes are supported.

## QUICK REFERENCE DATA

SYMBOL	PARAMETER	MIN.	TYP.	MAX.	UNIT
V <sub>DD</sub>	supply voltage	4.5	5.0	5.5	V
I <sub>DD</sub>	supply current	–	30	–	mA
V <sub>syn</sub>	CVBS sync amplitude	0.1	0.3	0.6	V
V <sub>vid</sub>	CVBS video amplitude	0.7	1.0	1.4	V
T <sub>amb</sub>	operating ambient temperature	–20	–	+70	°C
T <sub>stg</sub>	storage temperature	–55	–	+125	°C

## ORDERING INFORMATION

TYPE NUMBER	PACKAGE			
	PINS	PIN POSITION	MATERIAL	CODE
SAA5252P	24	DIL	plastic	SOT101
SAA5252T	24	SO24L	plastic	SOT137-1



# Line twenty-one acquisition and display (LITOD)

SAA5252

## BLOCK DIAGRAM

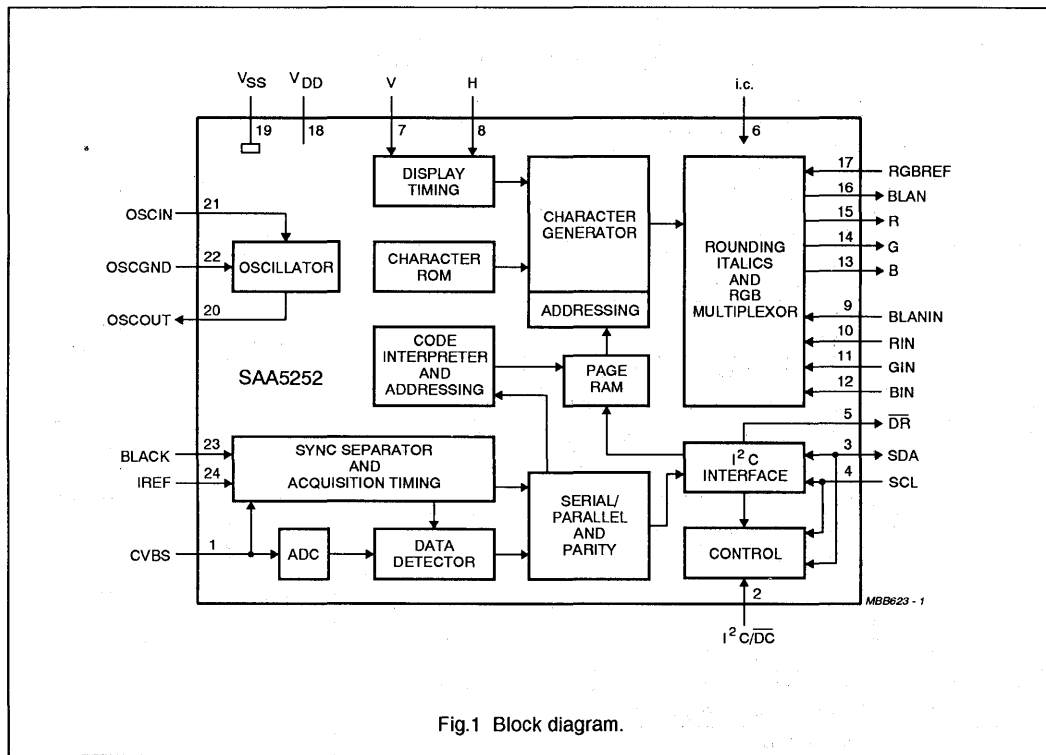

Fig.1 Block diagram.

# Line twenty-one acquisition and display (LITOD)

SAA5252

**PINNING**

SYMBOL	PIN	DESCRIPTION
CVBS	1	composite video input; signal should be connected via a 100 nF capacitor
I <sup>2</sup> C/DC	2	input selects I <sup>2</sup> C or Direct Control
SDA	3	serial data port for I <sup>2</sup> C-bus or mode select input for direct control
SCL	4	serial clock input for I <sup>2</sup> C-bus or mode select input for direct control
DR	5	data-ready signal to microcontroller (active-LOW) or mode select input for direct control
i.c.	6	internally connected; connect to V <sub>SS</sub> for normal operation
V	7	vertical reference input for display timing
H	8	horizontal reference input for display timing
BLANIN	9	video blanking input from external OSD device
RIN	10	RED video input from external OSD device
GIN	11	GREEN video input from external OSD device
BIN	12	BLUE video input from external OSD device
B	13	BLUE video output
G	14	GREEN video output
R	15	RED video output
BLAN	16	video blanking output
RGBREF	17	input voltage defining output HIGH level for RGB pins for closed captioning output
V <sub>DD</sub>	18	+5 V supply
V <sub>SS</sub>	19	0 V ground
OSCOUT	20	oscillator output
OSCIN	21	oscillator input
OSCGND	22	oscillator ground
BLACK	23	video black level storage input; connected to V <sub>SS</sub> via 100 nF capacitor
IREF	24	reference current input; connected to V <sub>SS</sub> via 27 kΩ resistor

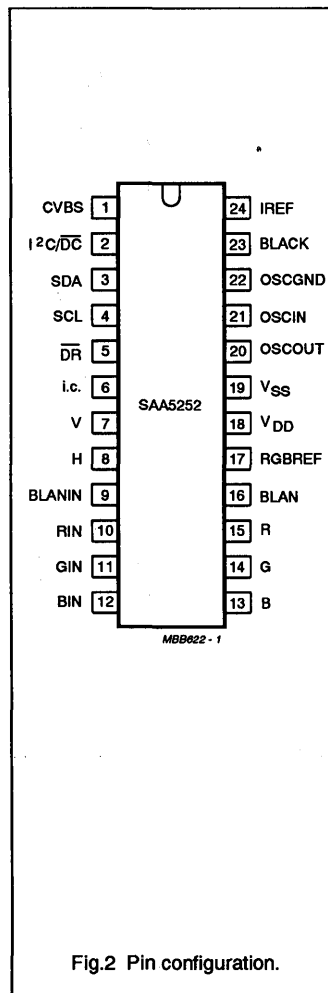

Fig.2 Pin configuration.

# Line twenty-one acquisition and display (LITOD)

SAA5252

## LIMITING VALUES

In accordance with the Absolute Maximum Rating System (IEC 134).

SYMBOL	PARAMETER	CONDITIONS	MIN.	MAX.	UNIT
$V_{DD}$	supply voltage (all supplies)		-0.3	+6.5	V
$V_{Imax}$	maximum input voltage (any input)	note 1	-0.3	$V_{DD} + 0.5$	V
$V_{Omax}$	maximum output voltage (any output)	note 1	-	$V_{DD} + 0.5$	V
$V_{dif}$	difference between $V_{SS}$ and OSCGND		-	$\pm 0.25$	V
$I_{IOK}$	DC input or output diode current		-	$\pm 20$	mA
$I_{Omax}$	maximum output current (each output)		-	$\pm 10$	mA
$T_{amb}$	operating ambient temperature		-20	+70	°C
$T_{stg}$	storage temperature		-55	+125	°C
$V_{es}$	electrostatic handling				
	human body model	note 2	-2000	+2000	V
	machine model	note 3	-200	+200	V

### Notes

1. This maximum value has an absolute maximum of 6.5 V independent of  $V_{DD}$ .
2. The human body model ESD simulation is equivalent to discharging a 100 pF capacitor via a 1.5 k $\Omega$  resistor, which produces a single discharge transient. Reference "Philips Semiconductors Test Method UZW-BO/FQ-A302 (similar to MIL-STD 883C method 3015.7)".
3. The machine model ESD simulation is equivalent to discharging a 200 pF capacitor via a resistor and series inductor with effective dynamic values of 25  $\Omega$  and 2.5  $\mu$ H, which produces a damped oscillating discharge. Reference "Philips Semiconductors Test Method UZW-BO/FQ-B302 (similar to EIAJ IC-121 Test Method 20 condition C)".

### Quality

This device will meet the requirements of the "Philips Semiconductors General Quality Specification UZW-BO/FQ-0601" in accordance with "Quality Reference Pocketbook (order number 9398 510 34011)". This details the acceptance criteria for all Q & R tests applied to the product.

# Line twenty-one acquisition and display (LITOD)

SAA5252

**CHARACTERISTICS**
 $V_{DD} = 5$  to  $5.5$  V;  $V_{SS} = 0$  V;  $T_{amb} = -20$  to  $+70$  °C; unless otherwise specified.

SYMBOL	PARAMETER	CONDITIONS	MIN.	TYP.	MAX.	UNIT
<b>Supplies</b>						
$V_{DD}$	supply voltage		4.5	5.0	5.5	V
$I_{DDtot}$	total supply current		–	30	–	mA
<b>Inputs</b>						
CVBS (PIN 1)						
$V_{syn}$	sync voltage amplitude		0.1	0.3	0.6	V
$V_{vid(p-p)}$	video voltage amplitude (peak-to-peak value)		0.7	1.0	1.4	V
$V_{dat}$	caption data voltage amplitude		0.25	0.35	0.49	V
$Z_{source}$	source impedance		–	–	250	$\Omega$
$V_I$	input switching voltage level of sync separator		1.7	2.0	2.3	V
$Z_I$	input impedance		2.5	5	–	k $\Omega$
$C_I$	input capacitance		–	–	10	pF
IREF (PIN 24)						
$R_{24}$	resistor to ground		–	27	–	k $\Omega$
$V_{24}$	voltage on pin 24		–	$\frac{1}{2}V_{DD}$	–	V
H (PIN 8)						
$V_{IL}$	LOW level input voltage		–0.3	–	+0.8	V
$V_{IH}$	HIGH level input voltage		2.0	–	$V_{DD} + 0.5$	V
$I_{LI}$	input leakage current	$V_I = 0$ to $V_{DD}$	–10	–	+10	$\mu$ A
$I_{Imax}$	maximum input current		–1	–	+1	mA
$C_I$	input capacitance		–	–	10	pF
$t_r$	pulse rise time		–	–	5	$\mu$ s
$t_f$	pulse fall time		–	–	5	$\mu$ s
$t_w$	pulse width					
	scan mode 1H		1	12	63	$\mu$ s
	scan mode 2H		1	6	31	$\mu$ s
V (PIN 7)						
$V_{IL}$	LOW level input voltage		–0.3	–	+0.8	V
$V_{IH}$	HIGH level input voltage		2.0	–	$V_{DD} + 0.5$	V
$I_{LI}$	input leakage current	$V_I = 0$ to $V_{DD}$	–10	–	+10	$\mu$ A
$I_{Imax}$	maximum input current		–1	–	+1	mA
$C_I$	input capacitance		–	–	10	pF
$t_r$	pulse rise time		–	–	5	ns
$t_f$	pulse fall time		–	–	5	ns
$t_w$	pulse width		1	–	–	$\mu$ s

# Line twenty-one acquisition and display (LITOD)

SAA5252

SYMBOL	PARAMETER	CONDITIONS	MIN.	TYP.	MAX.	UNIT
RGBREF (PIN, 17)						
$V_I$	input voltage		-0.3	-	$V_{DD}$	V
$I_{LI}$	input leakage current	$V_I = 0$ to $V_{DD}$	-10	-	+10	$\mu A$
R, G AND B (PINS 15, 14 AND 13; NOTE 1)						
$V_{IL}$	LOW level input voltage		-0.3	-	0.8	V
$V_{IH}$	HIGH level input voltage		2.0	-	$V_{DD} + 0.5$	V
$Z_I$	input impedance		2.5	5.0	-	k $\Omega$
BLANIN (PIN 9)						
$V_{IL}$	LOW level input voltage		-0.3	-	0.8	V
$V_{IH}$	HIGH level input voltage		2.0	-	$V_{DD} + 0.5$	V
$I_{LI}$	input leakage current	$V_I = 0$ to $V_{DD}$	-10	-	+10	$\mu A$
$t_r$	input rise time	between 10% and 90%	-	-	80	ns
$t_f$	input fall time	between 90% and 10%	-	-	80	ns
$1^{2C}/DC$ (PIN 2)						
$V_{IL}$	LOW level input voltage		0	-	0.8	V
$V_{IH}$	HIGH level input voltage		2.0	-	$V_{DD}$	V
$I_{LI}$	input leakage current	$V_I = 0$ to $V_{DD}$	-10	-	+10	$\mu A$
SCL (PIN 4)						
$V_{IL}$	LOW level input voltage		-0.3	-	1.5	V
$V_{IH}$	HIGH level input voltage		3.0	-	$V_{DD} + 0.5$	V
$f_{clk}$	clock frequency		0	-	100	kHz
$t_r$	input rise time	between 10% and 90%	-	-	2	$\mu s$
$t_f$	input fall time	between 90% and 10%	-	-	2	$\mu s$
$I_{LI}$	input leakage current	$V_I = 0$ to $V_{DD}$	-10	-	+10	$\mu A$
$C_I$	input capacitance		-	-	10	pF
<b>Inputs/outputs</b>						
CERAMIC RESONATOR (PINS 20, 21 AND 22; SEE FIG.5)						
$f_{osc}$	oscillator frequency		11.82	12	12.18	MHz
C0	parallel capacitance		-	5.35	-	pF
C1	series capacitance		-	37.4	-	pF
L1	series inductance		-	35.5	-	$\mu H$
R1	series resistance		-	6	25	$\Omega$
BLACK (PIN 23)						
$C_{black}$	storage capacitor to ground		-	100	-	nF
$V_{black}$	black level voltage for nominal sync amplitude		1.8	2.15	2.5	V
$I_{LI}$	input leakage current	$V_I = 0$ to $V_{DD}$	-10	-	+10	$\mu A$

# Line twenty-one acquisition and display (LITOD)

SAA5252

SYMBOL	PARAMETER	CONDITIONS	MIN.	TYP.	MAX.	UNIT
<b>SDA (PIN 3; OPEN DRAIN)</b>						
$V_{IL}$	LOW level input voltage		-0.3	-	+1.5	V
$V_{IH}$	HIGH level input voltage		3.0	-	$V_{DD} + 0.5$	V
$I_{LI}$	input leakage current	$V_I = 0$ to $V_{DD}$	-10	-	+10	$\mu$ A
$C_I$	input capacitance		-	-	10	pF
$t_r$	input rise time	between 10% and 90%	-	-	2	$\mu$ s
$t_f$	input fall time	between 90% and 10%	-	-	2	$\mu$ s
$V_{OL}$	LOW level output voltage	$I_{OL} = 3$ mA	0	-	0.5	V
$t_f$	output fall time	between 3 V and 1 V	-	-	200	ns
$C_L$	load capacitance		-	-	400	pF
<b>DR (PIN 5; OPEN DRAIN)</b>						
$V_{IL}$	LOW level input voltage		-0.3	-	+1.5	V
$V_{IH}$	HIGH level input voltage		3.0	-	$V_{DD} + 0.5$	V
$I_{LI}$	input leakage current	$V_I = 0$ to $V_{DD}$	-10	-	+10	$\mu$ A
$V_{OL}$	LOW level output voltage	$I_{OL} = 1.6$ mA	0	-	0.4	V
$t_f$	output fall time	between 4 V and 1 V with 3.3 k $\Omega$ to 5 V	-	-	50	ns
$C_L$	load capacitance		-	-	100	pF
<b>Outputs</b>						
<b>R, G AND B (PINS 15, 14 AND 13; CAPTION MODE)</b>						
$V_{OL}$	LOW level output voltage	$I_{OL} = +2$ mA	0	-	0.2	V
$V_{OH}$	HIGH level output voltage	$I_{OH} = -2$ mA	$V_{17} - 0.3$	$V_{17}$	$V_{17} + 0.4$	V
$Z_O$	output impedance		-	-	200	$\Omega$
$C_L$	load capacitance		-	-	50	pF
$t_r$	output rise time	between 10% and 90%	-	-	10	ns
$t_f$	output fall time	between 90% and 10%	-	-	10	ns
<b>BLAN (PIN 16)</b>						
$V_{OL}$	LOW level output voltage	$I_{OL} = +2$ mA	0	-	0.4	V
$V_{OH}$	HIGH level output voltage	$I_{OH} = -2$ mA	1.1	-	2.8	V
$C_L$	load capacitance		-	-	50	pF
$t_r$	output rise time	between 10% and 90%	-	-	10	ns
$t_f$	output fall time	between 90% and 10%	-	-	10	ns
$t_{skew}$	skew delay time between display and R, G, B, BLAN		-	-	10	ns

Line twenty-one acquisition and display  
(LITOD)

SAA5252

SYMBOL	PARAMETER	CONDITIONS	MIN.	TYP.	MAX.	UNIT
<b>I<sup>2</sup>C timing (see Fig.3)</b>						
t <sub>LOW</sub>	clock LOW time		4	-	-	μs
t <sub>HIGH</sub>	clock HIGH time		4	-	-	μs
t <sub>SU;DAT</sub>	data set-up time		250	-	-	ns
t <sub>HD;DAT</sub>	data hold time		170	-	-	ns
t <sub>SU;STO</sub>	set-up time from clock HIGH-to-STOP		4	-	-	μs
t <sub>BUF</sub>	START set-up time following a STOP		4	-	-	μs
t <sub>HD;STA</sub>	START hold time		4	-	-	μs
t <sub>SU;STA</sub>	START set-up time following clock LOW-to-HIGH transition		4	-	-	μs
t <sub>r</sub>	output rise time	between 10% and 90%	-	-	10	ns
t <sub>f</sub>	output fall time	between 90% and 10%	-	-	10	ns

**Note**

1. These inputs are analog, V<sub>IL</sub> and V<sub>IH</sub> values are quoted as a guide for digital RGB users.

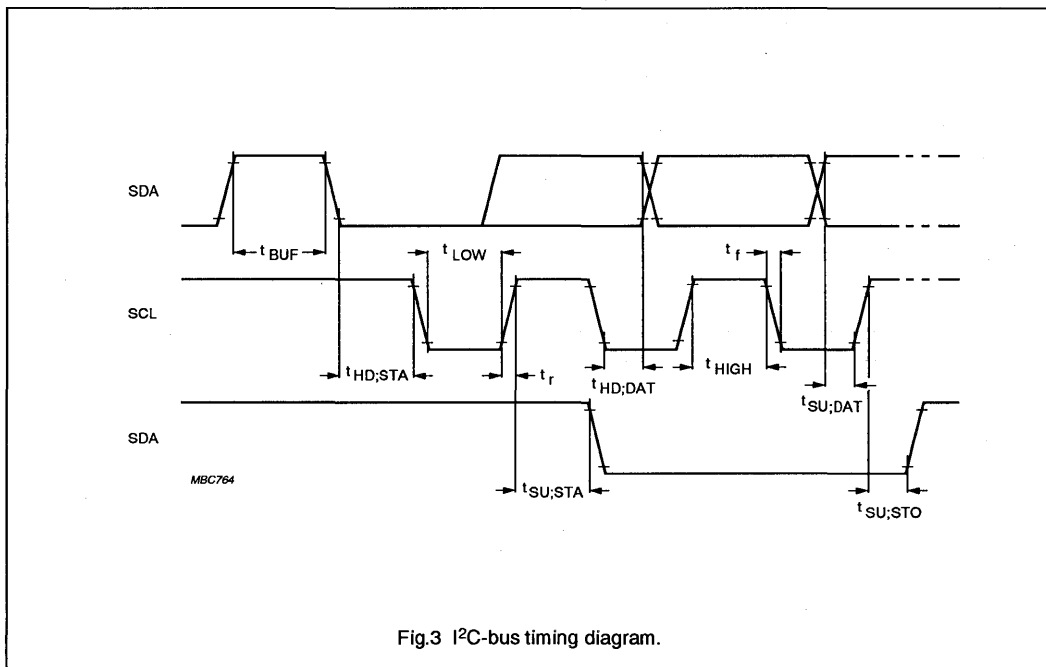
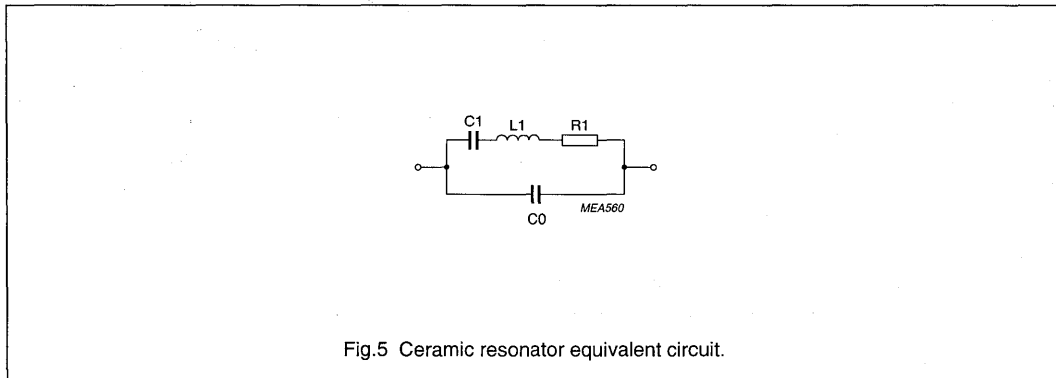
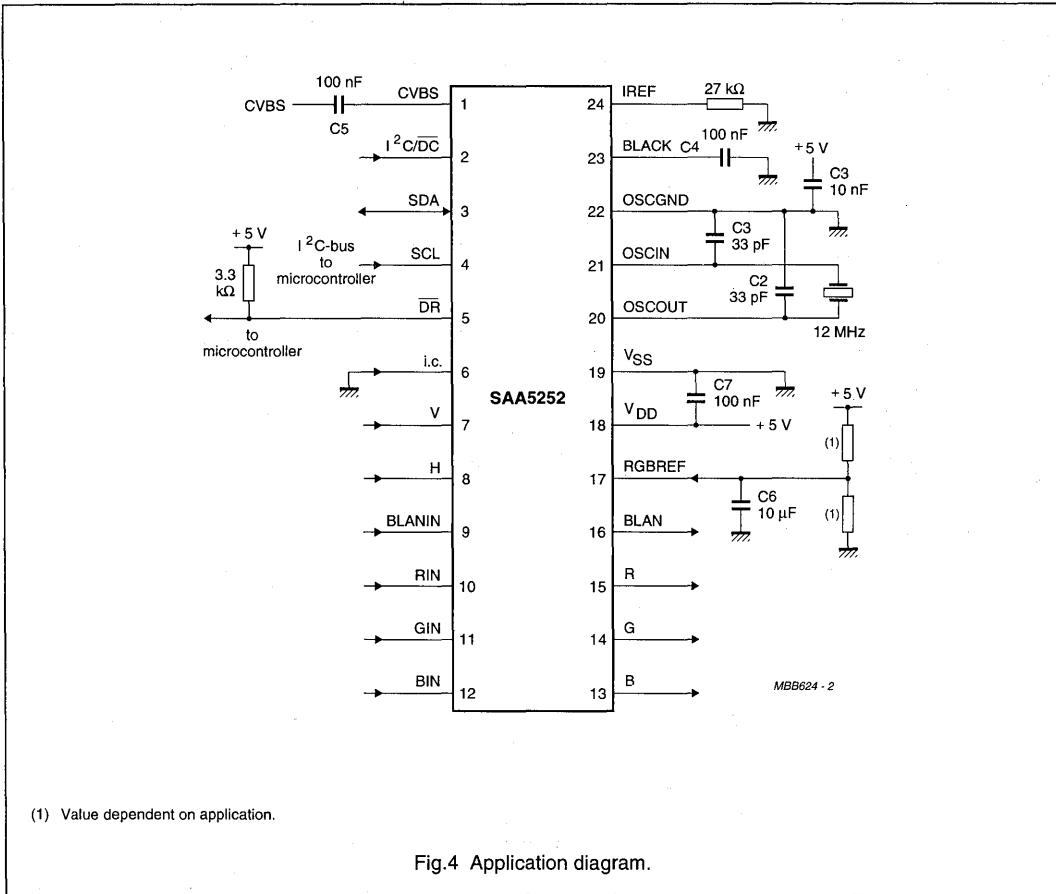

Fig.3 I<sup>2</sup>C-bus timing diagram.

# Line twenty-one acquisition and display (LITOD)

SAA5252

## APPLICATION INFORMATION





# Line twenty-one acquisition and display (LITOD)

SAA5252

## DISPLAY GENERATOR

### General Description

The displayed characters are defined on a 5-by-12 matrix within a 7-by-13 window, allowing one blank pixel either side of the character and a blank pixel row above. There are a number of display options available controlled by Register 1, or external pins in 'stand-alone' mode.

The three display modes are video, text and caption, the device is powered up in the video mode.

The display generator reads the Pre-amble Address Code (PAC) then the data associated with that row. Each character is then rounded after which it can be italicized and/or underlined, depending on the PAC or mid-row codes, before being passed on to the output circuitry. Figure 6 shows the character set.

### Display of external On-Screen Display (OSD) facilities

The R, G, B and BLAN outputs of the display have the capability to be put in a 3-state mode allowing other OSD devices to take control of the television R, G, B and BLAN signals.

When the BLANIN is held HIGH then the R, G, B and BLAN outputs from display are disabled and the R, G, B and BLAN signals come directly from the RGBIN and BLANIN inputs. This will allow On-Screen Display to be placed on top of the captioning without any corruption, leaving the captions intact when the On-Screen Display is switched off (BLANIN goes LOW). In this form of operation the RGBIN and RGBOUT pins can be considered transparent; BLANIN goes through the normal output buffer to BLAN.

**Table 1** Register map (WRITE).

REGISTER	D7	D6	D5	D4	D3	D2	D1	D0
00	DF1/2	RGB, BLAN +ve/-ve	H +ve/-ve	V +ve/-ve	H3	H2	H1	H0
01	CLEAR	CH 2/1	NARROW /WIDE	ACQ OFF	EN1	EN0	M1	M0
02	-	-	-	-	ROW3	ROW2	ROW1	ROW0
03	-	-	-	COL4	COL3	COL2	COL1	COL0
04	-	OSD6	OSD5	OSD4	OSD3	OSD2	OSD1	OSD0

**Table 2** Register map (READ).

REGISTER	D7	D6	D5	D4	D3	D2	D1	D0
00	POR	0	0	0	F1/F2	EDS	PARITY SHUTDOWN	DATA READY
01	PARITY ERROR	DATA BIT 7	DATA BIT 6	DATA BIT 5	DATA BIT 4	DATA BIT 3	DATA BIT 2	DATA BIT 1
02	PARITY ERROR	DATA BIT 7	DATA BIT 6	DATA BIT 5	DATA BIT 4	DATA BIT 3	DATA BIT 2	DATA BIT 1



# Line twenty-one acquisition and display (LITOD)

SAA5252

## I<sup>2</sup>C INTERFACE

### Description of WRITE registers

The write subaddresses auto increment from 0 through to 4 at which point they stay until a new write subaddress is sent. Registers are set to all logic 0 at power-up.

**Table 3** Register 0 WRITE (Control Byte 1).

BIT	DESCRIPTION
D0 to D3	H0 to H3 set the offset position from the start of the horizontal sync pulse, set to a nominal value on reset.
D4	Vertical sync pulse expected to be negative going logic 0 or positive-going logic 1.
D5	Horizontal sync pulse expected to be negative going logic 0 or positive-going logic 1.
D6	Video outputs will be positive going logic 0 or negative-going logic 1.
D7	Data field select. When set to logic 0 Field 1 is decoded, when set to logic 1 Field 2 is decoded.

**Table 4** Register 1 WRITE (Control Byte 2).

BIT	DESCRIPTION
D0, D1	Display mode selection bits. Table 8 shows the possible display modes.
D2, D3	Enhanced caption mode selection bits. Table 9 shows the possible enhanced caption modes.
D4	When set to logic 1 acquisition of caption data is inhibited to allow the display to be used for On-Screen Display purposes.
D5	Acquisition window selection. When set to logic 0 only Line 21 is checked for caption data. When set to logic 1, lines 19 to 23 of both fields are checked, allowing encrypted video signals to be handled.
D6	User channel selection.
D7	Clears the page memory when set HIGH. The page memory will be within two fields (30 ms).

**Table 5** Register 2 WRITE (On-Screen Display data row address).

BIT	DESCRIPTION
D0 to D3	Row 0 to 3 sets the row address for On-Screen Display. This stored value will be incremented by overflow increments of Register 3.

**Table 6** Register 3 WRITE (On-Screen Display data column address).

BIT	DESCRIPTION
D0 to D4	Columns 0 to 4 sets the column address for On-Screen Display. This stored value will be incremented by writes to Register 4.

**Table 7** Register 4 WRITE (On-Screen Display data).

BIT	DESCRIPTION
D0 to D6	OSD0 to OSD6, On-Screen Display data bits writing to this register causes Register 3 to increment its stored value.

# Line twenty-one acquisition and display (LITOD)

SAA5252

**Table 8** Display modes.

DISPLAY MODE OPTIONS	M1	M0
Video only	0	0
Text mode	0	1
Normal caption mode	1	0
Enhanced caption mode	1	1

**Table 9** Enhanced caption modes.

ENHANCED CAPTION MODES	EN1	EN0
Enhanced caption modes	EN1	EN0
Shadowed character/Video background	0	0
Shadowed character/Mesh background	0	1
Normal character/Video background	1	0
Normal character/Mesh background	1	1

**Description of READ registers**

The read subaddresses auto increment from 0 through to 2 at which point they stay until a new read subaddress is sent. All the bits in Table 10 are reset to logic 0 after the register is read.

**Table 10** Register 0 READ (status).

BIT	DESCRIPTION
D0	Data ready (new data has been acquired).
D1	Parity error shut-down, goes HIGH when SAA5252 has a parity shut-down condition.
D2	Indicates the following bytes are extended data service bytes.
D3	Indicates Field 1 or Field 2 data bytes.
D7	Indicates Power-On Reset (POR) has occurred, all I <sup>2</sup> C-bus write registers have been reset to logic 0.

**Table 11** Register 1 READ (first data byte).

BIT	DESCRIPTION
D0 to D6	Data Bit 1 to Data Bit 7 (see note 1).
D7	Parity error flag bit. Bit goes HIGH when a parity error has occurred.

**Note**

- In the Line 21, specification data bits are numbered D1 to D8.

**Table 12** Register 2 READ (second data byte).

BIT	DESCRIPTION
D0 to D6	Data Bit 1 to Data Bit 7 (see note 1).
D7	Parity error flag bit. Bit goes HIGH when a parity error has occurred.

**Note**

- In the Line 21, specification data bits are numbered D1 to D8.

## Line twenty-one acquisition and display (LITOD)

SAA5252

### Interface to microcontroller using I<sup>2</sup>C-bus

The interface to the microcontroller is via the two-wire serial I<sup>2</sup>C-bus, and optionally by a Data-Ready signal (DR). On power up the microcontroller initializes the device by an I<sup>2</sup>C-bus WRITE to Registers 0 (Control Byte 1). The I<sup>2</sup>C-bus subaddress is then auto incremented to point to Register 1 (Control Byte 2). These two registers configure the device to the users requirements.

If the device is to be used for data acquisition only, then there are three methods by which the microcontroller can be informed of the arrival of valid Line 21 data:

- It can poll the  $\overline{DR}$  pin, if the function has been enabled, and wait for it to go LOW.
- It can use the negative edge of the  $\overline{DR}$  signal to cause an interrupt.
- It can poll the Data Ready bit (bit D0 of the status byte, I<sup>2</sup>C-bus READ Register 0).

When valid data is detected, the microcontroller must initiate an I<sup>2</sup>C-bus READ of Registers 0, 1 and 2. The first and second data bytes from the most recently received Line 21 are in Register 1 and Register 2 respectively.

The  $\overline{DR}$  pin, and the Data Ready bit (Status bit D0) will be cleared after any register has been read. POR is reset after Register 0 has been read.

### 'STAND-ALONE' (NON I<sup>2</sup>C-BUS) OPERATION

To set the SAA5252 for 'stand-alone' operation pin 2 (I<sup>2</sup>C/ $\overline{DC}$ ) is tied LOW. This will change the operation of the SCL, SDA and DR pins to mode select inputs which will select as shown in Table 13.

In the caption mode the SAA5252 operates in the basic Normal character/Black background mode. This complies with the FCC ruling. In the Enhanced caption mode the set-up will be Shadowed character/Video background. SDA and SCL in the 'stand-alone' operation act as bits M0 and M1 in Table 8.

**Table 13** Stand-alone modes.

$\overline{DR}$	SCL	SDA	MODE OF OPERATION	CHANNEL RECEPTION
0	0	0	Video mode	Channel 1
0	0	1	Text mode	Channel 1
0	1	0	Normal captions	Channel 1
0	1	1	Enhanced captions	Channel 1
1	0	0	Video mode	Channel 2
1	0	1	Text mode	Channel 2
1	1	0	Normal captions	Channel 2
1	1	1	Enhanced captions	Channel 2

# Single chip economy 10 page teletext/ TV microcontroller

## SAA5296

### GENERAL DESCRIPTION

The SAA5296 is a ten page teletext decoder and TV control IC. The device will decode 625 line and 525 line based WST transmissions and provides tuner control functions and On Screen display (OSD) facilities. The teletext decoder hardware is a derivative of IVT1.1X and the TV control functionality is provided by an on-chip industry standard 80C51 microcontroller. A ten page static RAM is included on board providing a single chip teletext decoder and OSD display memory. The SAA5296 is intended for use as the central control mechanism in a television receiver.

The SAA5296 will be available as a mask programmed ROM version. An EEPROM version will also be available for software development. Both versions are available in a SDIL-52 package and QFP-80 package. The QFP-80 package also has the capability of external ROM.

### FEATURES

#### General

- Complete Teletext decoder and TV control in a single integrated circuit
- +5V power supply
- RGB interface to standard colour decoder ICs, push pull output drive

- Single crystal oscillator for teletext decoder, display and microcontroller

#### Text

- Ten page (10240 × 8) on board teletext and OSD memory
- Eastern European, Western European and Turkish language covered in one device
- 625 line and 525 line acquisition and display
- Acquisition and decoding of VPS data (EBU PDC System A)
- Simultaneous acquisition and storage of 10 teletext pages
- Double size, width and height character capability for OSD
- Enhanced display features including meshing, shadowing and additional display attributes
- Definable OSD border colours in TV mode
- Extension packet and Inventory page storage
- Automatic detection of Fastext
- Page clearing within one line
- Display clock derived internally to reduce peripheral components to a minimum

- Packet 26 engine for real time processing of accented (and other) characters
- Page links in packet 27, and packet 8/30 are Hamming decoded
- 260 characters in mask programmed ROM
- optional storage of packet 24 in display memory
- Video signal quality detection
- Automatic FRAME output control with manual override
- Slave synchronization
- Standby mode for teletext hardware

#### Microcontroller

- 80C51 instruction set
- 32Kbytes mask programmed ROM
- 768 bytes of RAM
- Eight 6-bit PWMs. One 14-bit PWM for tuning control
- Four ADCs implemented as 8 bit DAC and comparator with 4 multiplexed inputs
- 4 high current open drain port output
- Master and slave byte wide I<sup>2</sup>C-bus

### ORDERING INFORMATION

EXTENDED TYPE NUMBER	VERSION	PACKAGE			
		PINS	PIN POSITION	MATERIAL	CODE
SAA5296ZP/nnn (note 1)	ROM	52	SDIL	plastic	SOT247
SAA5296H/nnn (note 1)	Internal/External ROM	80	QFP	plastic	SOT318
SAA5296XP/NV	EEPROM	52	SDIL	plastic	SOT247
SAA5296H/NV	EEPROM	80	QFP	plastic	SOT318

#### NOTE:

1. nnn refers to the program mask number.

### QUICK REFERENCE DATA

SYMBOL	PARAMETER	MIN.	TYP.	MAX.	UNIT
V <sub>DD</sub>	Supply voltage	4.5	5.0	5.5	V
I <sub>DD</sub>	Supply current	–	115	–	mA
I <sub>DDS</sub>	Supply current – standby text	–	30	40	mA
f <sub>CLK</sub>	Clock frequency	–	12	–	MHz
T <sub>amb</sub>	Operating ambient temperature	–20	–	+70	°C

# Single chip economy 10 page teletext/ TV microcontroller

SAA5296

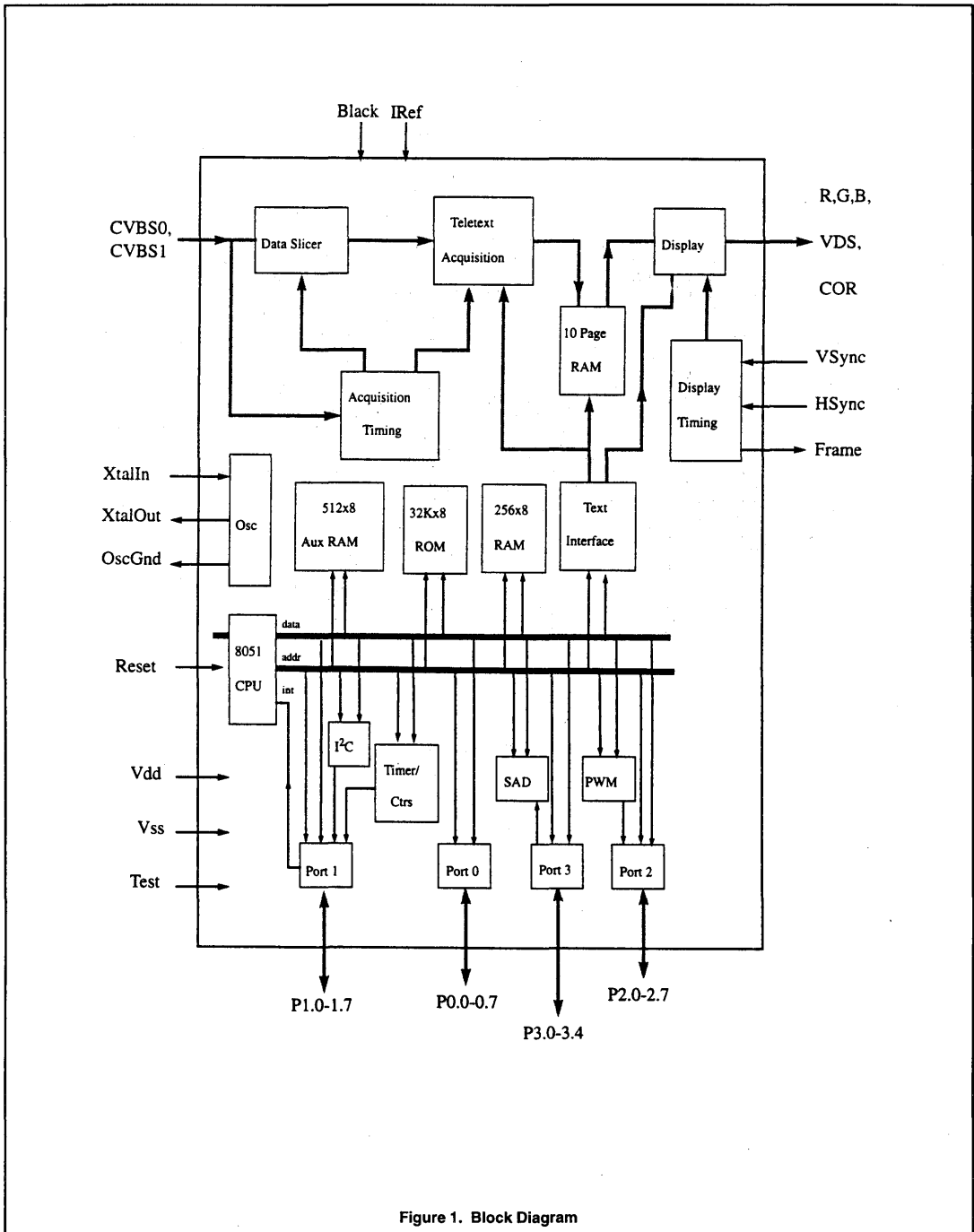

Figure 1. Block Diagram





# Single chip economy 10 page teletext/ TV microcontroller

SAA5296

## PINNING

SYMBOL	PIN (SDIL-52)	PIN (QFP-80)	DESCRIPTION
P2.0–P2.7	1–8 1 2–8	77–80, 9, 8, 1, 2 77 78–80, 9, 8, 1, 2	<b>PORT 2:</b> 8 bit open drain bidirectional port. Alternate functions include: <b>TPWM (P2.0)</b> – This is the output for the 14-bit high precision PWM. <b>PWM0–6 (P2.1–P2.7)</b> – Outputs for the 6-bit PWMs 0 through 6.
P3.0–P3.4	9–12, 30 9–11 30	3, 5–7, 44, 46, 48 3, 5–7 44	<b>PORT 3 (Note 1):</b> 5 bit open drain port. P3.0–P3.2 are inputs only. P3.3–P3.4 are bidirectional. Alternate functions include: <b>ADC0–ADC3 (3.0–P3.3)</b> – Inputs for the software ADC facility. <b>PWM7 (P3.4)</b> – Output for the 6-bit PWM 7.
VSSD	13	12	<b>Digital ground</b>
P0.0–P0.7	14–21	14–16, 20, 21, 25–27	<b>PORT 0:</b> 8 bit open drain bidirectional port. P0.5 and P0.6 have 10mA current sinking capability at 0.5 V for direct drive of LEDs.
VSSA	22	27	<b>Analog ground</b>
CVBS0, CVBS1	23, 24	28, 29	<b>CVBS input:</b> This signal is applied via a 100nF capacitor. Maximum input 1V pp.
BLACK	25	30	<b>Black level input:</b> Input to store CVBS black level. A 100nF capacitor should be connected to VSSA.
IREF	26	31	<b>IREF:</b> Reference current for analog circuits. For correct operation, a 27K resistor should be connected to VSSA.
FRAME	27	36	<b>Frame output:</b> For use in non-interlaced displays. During teletext off, teletext mixed with TV picture and subtitles this pin is inactive. In full teletext mode this pin provides a 25Hz square wave.
TEST	28	37	<b>Test:</b> Test control pin.
COR	29	38	<b>Contrast reduction:</b> Open drain, active low output which allows selective contrast reduction of the television picture to enhance a mixed mode display.
RGBREF	31	39	<b>RGB reference:</b> Drive level reference for RGB outputs.
B	32	409	<b>Blue:</b> Dot rate character output of the blue color information. The high voltage level is defined by the RGBREF pin. Can source 4mA.
G	33	41	<b>Green:</b> Dot rate character output of the green color information. The high voltage level is defined by the RGBREF pin. Can source 4mA.
R	34	42	<b>Red:</b> Dot rate character output of the red color information. The high voltage level is defined by the RGBREF pin. Can source 4mA.
VDS	35	43	<b>Video/Data switch:</b> Push-pull output for blanking the TV picture.
HSYNC	36	45	<b>Horizontal sync:</b> A dedicated input for a TTL-level version of the horizontal sync pulse. The polarity of this pulse is programmable by register 1 bit D1.
VSYNC	37	47	<b>Vertical sync:</b> A dedicated input for a TTL-level version of the horizontal sync pulse. The polarity of this pulse is programmable by register 1 bit D0.
VDDA	38	49	<b>Analog power supply:</b> 5V supply for analog circuitry.
VDDT	39	51	<b>Teletext power supply:</b> 5V supply for teletext digital circuitry.
OSCGND	40	56	<b>Oscillator Ground:</b> Ground for crystal oscillator.
XTALIN	41	57	<b>Crystal Input:</b> 12 MHz crystal oscillator input.
XTALOUT	42	58	<b>Crystal Output:</b> 12 MHz crystal oscillator output.
RESET	43	59	<b>Reset:</b> If this pin is high for 2 machine cycles (24 oscillator periods) while the oscillator is running, the SAA5290 is reset.
VDDM	44	62	<b>Microcontroller power supply:</b> 5V supply for the microcontroller digital circuitry.

# Single chip economy 10 page teletext/ TV microcontroller

SAA5296

SYMBOL	PIN (SDIL-52)	PIN (QFP-80)	DESCRIPTION
P1.0-P1.7	45-52 45 46 47 48 49 50	63, 64, 60, 61, 67, 68, 65, 66 63 64 60 61 65 66	<b>PORT 1:</b> 8 bit open drain bidirectional port. Alternate functions include:  <b>INT1 (P1.0)</b> – external interrupt 1 <b>T0 (P1.1)</b> – counter/timer 0 <b>INT0 (P1.2)</b> – external interrupt 0 <b>T1 (P1.3)</b> – counter/timer 1 <b>SCL (P1.6)</b> – serial clock input for I <sup>2</sup> C bus <b>SDA (P1.7)</b> – serial data port for I <sup>2</sup> C bus
Ref+	–	50	<b>Ref+:</b> Positive reference voltage for software ADC
Ref–	–	19	<b>Ref–:</b> Negative reference voltage for software ADC
RD	–	10	<b>RD:</b> External memory read strobe
WR	–	11	<b>WR:</b> External memory write strobe
PSEN	–	17	<b>Program store enable output:</b> Read strobe to external program memory.
ALE	–	18	<b>Address Latch Enable:</b> Output pulse for latching the low byte of the address during access to external memory.
EA	–	13	<b>Address Latch Enable:</b> Output pulse for latching the low byte of the address during access to external memory.
AD0-AD7	–	69-76	<b>AD0 – AD7:</b> External memory multiplexed low order address and data bus.
A8-A15	–	55-52, 35-32	<b>A8 – A15:</b> External memory high order address.

**NOTE:**

1. 7 bit open drain port QFP80 variant.

**MICROCONTROLLER INTERFACING**

The 80C51 CPU communicates with the peripheral functions using Special Function Registers (SFRs) which are addressed as direct RAM. The registers in the teletext decoder appear as normal SFRs in the microcontroller memory map, but are written to using a serial bus. This bus is controlled by dedicated hardware which uses a simple handshake system for software synchronization. The SFR map is given:

Address (hex)	8 bytes							
F8								
F0	B							
E8	SAD							
E0	ACC							
D8	S1CON	S1STA	S1DAT	S1ADR	PWM3	PWM4	PWM5	PWM6
D0	PSW		TDACL	TDACH	PWM7	PWM0	PWM1	PWM2
C8	TXT8	TXT9	TXT10	TXT11	TXT12	TXT14	TXT15	TXT16
C0	TXT0	TXT1	TXT2	TXT3	TXT4	TXT5	TXT6	TXT7
B8	TXT13	TXT17						
B0	P3							
A8	IE							
A0	P2							
98	SAD2							
90	P1							
88	TCON	TMOD	TL0	TL1	TH0	TH1		
80	P0	SP	DPL	DPH				PCON

# Single chip economy 10 page teletext/ TV microcontroller

SAA5296

The following SFRs are standard 8051 SFRs and their contents and application have not been changed for the SAA5296: ACC, B, PSW, P0, P1, P2, P3, PCON, TCON, TMOD, TL0, TH0, TL1, TH1, SP, DPL and DPH. SFRs S1CON, S1STA, S1ADR and S1DAT are standard P8xCE652 SFRs and their contents and application have not been changed for the SAA5296. The contents of the remaining registers are specific to the SAA5296 and are shown below:

Register	Bit 7	Bit 6	Bit 5	Bit 4	Bit 3	Bit 2	Bit 1	Bit 0
IE	EA	ES1	–	–	ET1	EX1	ET0	EX0
TXT0	X24 POSITION	DISPLAY X24	AUTO FRAME	DISABLE HDR ROLL	STATUS ROW ONLY	DISABLE FRAME	VPS ON	INV ON
TXT1	EXT PK OFF	8 BIT	ACQ OFF	X26	FULL FIELD	FIELD POLARITY	H POLARITY	V POLARITY
TXT2	–	REQ 3	REQ 2	REQ 1	REQ 0	SC2	SC1	SC0
TXT3	–	–	–	PRD4	PRD3	PRD2	PRD1	PRD0
TXT4	–	–	EAST/WEST	DISABLE DBL HT	B MESH ENABLE	C MESH ENABLE	TRANS ENABLE	SHADOW ENABLE
TXT5	BKGND OUT	BKGND IN	COR OUT	COR IN	TEXT OUT	TEXT IN	PICTURE ON OUT	PICTURE ON IN
TXT6	BKGND OUT	BKGND IN	COR OUT	COR IN	TEXT OUT	TEXT IN	PICTURE ON OUT	PICTURE ON IN
TXT7	STATUS ROW TOP	CURSOR ON	CONCEAL/ REVEAL	TOP/ BOTTOM	SINGL/DBL HEIGHT	BOX ON 24	BOX ON 1–23	BOX ON 0
TXT8	–	–	–	–	–	–	–	CVBS0/ CVBS1
TXT9	CURSOR FREEZE	CLEAR MEMORY	A0	R4	R3	R2	R1	R0
TXT10	–	–	C5	C4	C3	C2	C1	C0
TXT11	D7	D6	D5	D4	D3	D2	D1	D0
TXT12	625/525 SYNC	ROM VER R4	ROM VER R3	ROM VER R2	ROM VER R1	ROM VER R0	TXT ON	VIDEO QUALITY
TXT13	–	PAGE CLEARING	625/525 DISPLAY	525 TEXT	625 TEXT	PKT 8/30	FASTTEXT	TXT I/FACE BUSY
TXT14	–	–	–	–	PAGE 3	PAGE 2	PAGE 1	PAGE 0
TXT15	–	–	–	–	BLOCK 3	BLOCK 2	BLOCK 1	BLOCK 0
TXT16	–	Y2	Y1	Y0	–	–	X1	X2
TXT17	–	–	–	FORCE 625	FORCE 525	SCREEN COL 2	SCREEN COL 1	SCREEN COL 0
TDACL	TD7	TD6	TD5	TD4	TD3	TD2	TD1	TD0
TDACH	TDE	–	TD13	TD12	TD11	TD10	TD9	TD8
PWM0–5	PWE	–	PV5	PV4	PV3	PV2	PV1	PV0
SAD	VHI	CH1	CH0	ST	SAD7	SAD6	SAD5	SAD4
SAD2	–	–	–	–	SAD3	SAD2	SAD1	SAD0

## One Chip Frontend 1 (OFC1)

SAA7110

*Digital multistandard colour decoder with 2 A/D converters***SHORT DESCRIPTION**

The one chip frontend SAA7110 is a digital multistandard colour decoder (OCF1) on the basis of the digital TV-2 system with 2 integrated A/D converters, a clock generation circuit (CGC) and BCS- (Brightness, Contrast, Saturation) control.

**FEATURES**

- Six analog inputs (six times CVBS or three times Y/C or combinations)
- Three analog processing channels
- Three built in analog anti alias filters
- Analog signal adding of two channels
- Two Video CMOS 8-bit A/D- converters
- Full programmable static gain for the main channels or automatic gain control for the selected CVBS/Y channel
- Selectable signal (white) peak control
- Luminance and chrominance signal processing for standards PAL-B/G, NTSC-M, SECAM
- Full range HUE control
- Automatic detection of 50/60Hz field frequency -> automatic switching between standards PAL and NTSC, SECAM forceable
- Horizontal and vertical sync detection for all standards
- Cross-colour reduction by chrominance comb filtering for NTSC or special cross-colour cancellation for SECAM
- UV signal delay lines for PAL to correct chrominance phase errors
- The YUV bus supports a data rate of:  
(780 x f<sub>H</sub>) for 60 Hz 12.2727MHz (NTSC)  
(944 x f<sub>H</sub>) for 50 Hz 14.75MHz (PAL/SECAM)
- Square pixel-format with 768/640 active samples per line on the YUV bus
- CCIR 601 level compatible
- 4:2:2 and 4:1:1 YUV output formats in 8-bit resolution
- User programmable luminance peaking for aperture correction
- Compatible with memory-based features (line-locked clock, square pixel)
- Requires only one crystal (26.8MHz) for all standards
- Real-time status information output (RTCO)
- Brightness Contrast Saturation control for the YUV-bus
- Negation of picture possible
- One user programmable general purpose switch on an output pin
- Switchable between on-chip Clock Generation Circuit (CGC) and external CGC (SAA7197)
- Power On Control
- I<sup>2</sup>C-bus controlled

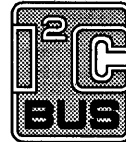
**QUICK REFERENCE DATA**

SYMBOL	PARAMETER	MIN	MAX	UNIT
V <sub>DD</sub>	digital supply voltage range	4.5	5.5	V
V <sub>DDA</sub>	analog supply voltage range	4.75	5.25	V
T <sub>amb</sub>	ambient temperature range	0	70	°C

**ORDERING AND PACKAGE INFORMATION**

EXTENDED TYPE NUMBER	PACKAGE			
	PINS	PIN POSITION	MATERIAL	CODE
SAA7110	68	PLCC	Plastic	SOT188CG14

# One Chip Frontend 1 (OCF1)

# SAA7110

## GENERAL DESCRIPTION

The CMOS circuit SAA7110, analog frontend and digital video decoder, is a highly integrated circuit for Desk Top Video applications. The decoder is based on the principle of line-

locked clock decoding. It runs square-pixel frequencies to achieve correct aspect ratio. Monitor controls are provided to ensure best display. The circuit is I<sup>2</sup>C-bus-controlled.

## 1. BLOCK DIAGRAM

FIGURE 1. BLOCK DIAGRAM

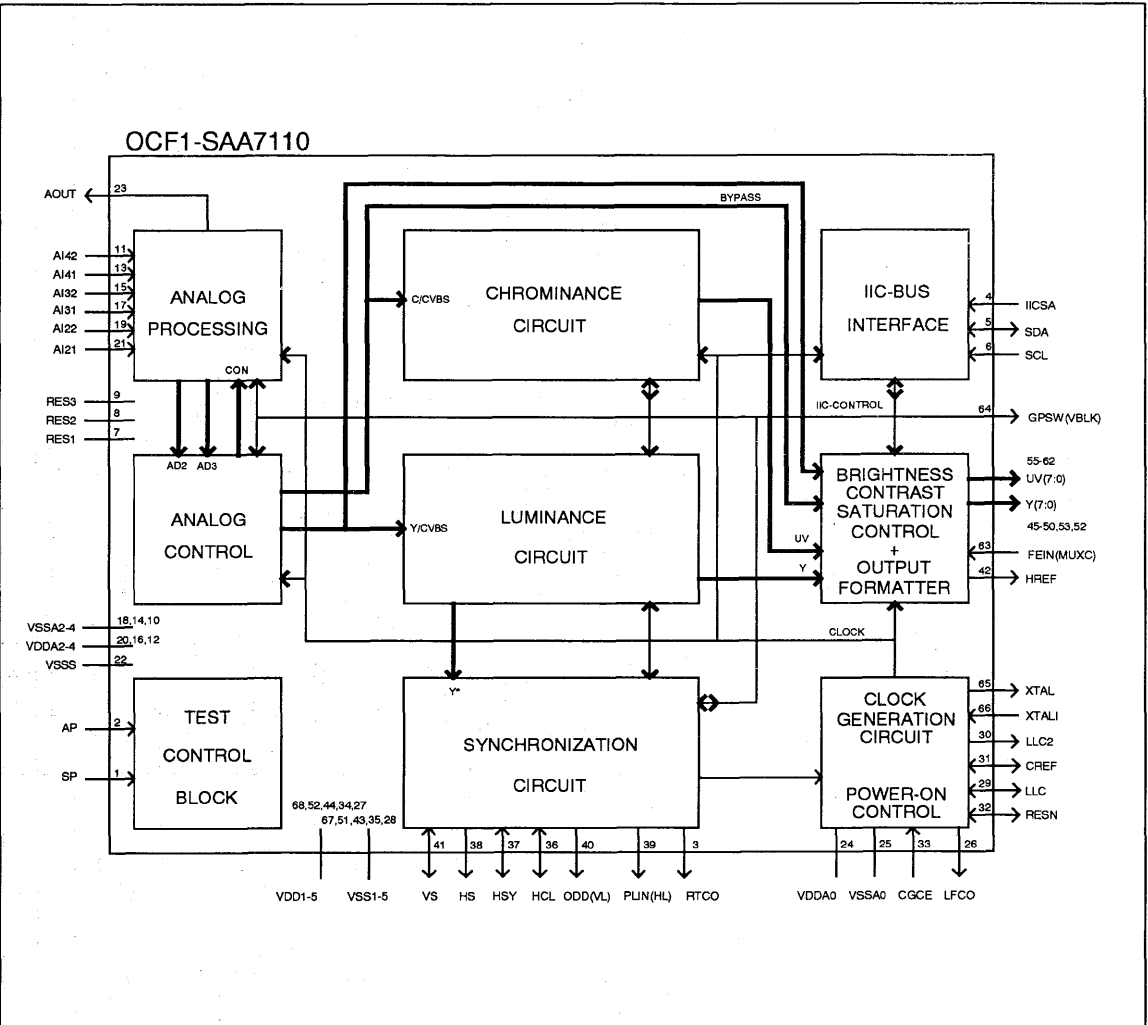

# One Chip Frontend 1 (OFC1)

# SAA7110

## 2. SYSTEM VIEW

FIGURE 2. SYSTEM VIEW

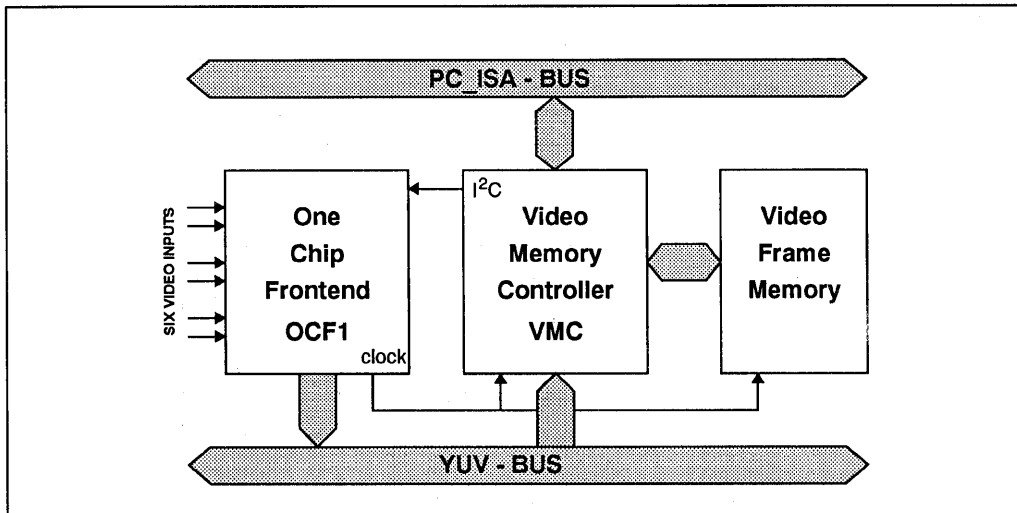

## 3. PINNING

TABLE 1. PINNING

PIN NO.	SYMBOL	I O P	DESCRIPTION
1	SP	I	SHIFT PIN for testing; connect to ground in normal operation
2	AP	I	ACTION PIN for testing; connect to ground in normal operation
3	RTCO	O	Real Time Control Output. This pin is used to fit out serially the increments of the HPLL and FSC-PLL and an information of the PAL- or SECAM-sequence
4	IICSA	I	IIC Slave Address select (0=9Ch(for write), 9Dh for read; 1=9Eh (for write), 9Fh for read)
5	SDA	I/O	I <sup>2</sup> C-bus SERIAL DATA input/output
6	SCL	I	I <sup>2</sup> C-bus SERIAL CLOCK input
7	RES1	-	Reserved pin 1 (do not connect))
8	RES2	-	Reserved pin 2 (do not connect))
9	RES3	-	Reserved pin 3 (do not connect))
10	V <sub>SSA4</sub>	P	ground for analog input 4
11	AI42	I	analog input 42
12	V <sub>DDA4</sub>	P	positive supply voltage (+ 5 V) for analog input 4
13	AI41	I	analog input 41
14	V <sub>SSA3</sub>	P	ground for analog input 3
15	AI32	I	analog input 32
16	V <sub>DDA3</sub>	P	positive supply voltage (+ 5 V) for analog input 3
17	AI31	I	analog input 31

## One Chip Frontend 1 (OFC1)

SAA7110

TABLE 1. PINNING

PIN NO.	SYMBOL	I O P	DESCRIPTION
18	V <sub>SSA2</sub>	P	ground for analog input 2
19	AI22	I	analog input 22
20	V <sub>DDA2</sub>	P	positive supply voltage (+ 5 V) for analog input 2
21	AI21	I	analog input 21
22	V <sub>SSS</sub>	P	SUBSTRATE ground connection
23	AOUT	O	Analog test OUTput (do not connect).
24	V <sub>DDA0</sub>	P	positive supply voltage (+ 5 V) for internal CGC (Clock Generation Circuit)
25	V <sub>SSA0</sub>	P	ground for internal CGC
26	LFCO	O	LINE FREQUENCY CONTROL output signal; this is the analog clock control signal driving the external CGC. The frequency is a multiple of the actual line frequency (nominally 7.375/6.13636 MHz). The signal has triangular form with a 4-bit accuracy.
27	V <sub>DD5</sub>	P	positive supply voltage (+ 5 V)
28	V <sub>SS5</sub>	P	ground
29	LLC	I/O	LINE LOCKED CLOCK I/O (CGCE=1 -> output; CGCE=0 -> input); this is the system clock, its frequency is 1888*f <sub>h</sub> for 50 Hz/625 lines per field systems and 1560*f <sub>h</sub> for 60 Hz/525 lines per field systems; or variable input clock up to 32MHz in input mode.
30	LLC2	O	Line Locked Clock output; f <sub>LLC2</sub> =0.5xf <sub>LLC</sub> ; (CGCE=1 -> output; CGCE=0 -> High impedance)
31	CREF	I/O	CLOCK REFERENCE I/O (CGCE=1 -> output; CGCE=0 -> input). This is a clock qualifier signal distributed by the internal or an external clock generator circuit (CGC). Using CREF all interfaces on the YUV bus are able to generate a bus timing with identical phase.
32	RESN	I/O	RESET active LOW I/O (CGCE=1 -> output; CGCE=0 -> input); sets the device into a defined state. All data outputs are in high impedance state. The I <sup>2</sup> C-bus is reset (waiting for start condition). Using the external CGC, the LOW period must be maintained for at least 30 LLC clock cycles.
33	CGCE	I	CGC Enable input signal, active HIGH; (CGCE=1 -> On chip CGC active; CGCE=0 -> External CGC mode: use SAA7197)
34	V <sub>DD4</sub>	P	positive supply voltage (+ 5 V)
35	V <sub>SS4</sub>	P	ground
36	HCL	I/O	HORIZONTAL CLAMPING pulse I/O (programmable via IIC-bit PULIO, PULIO=1 -> output, PULIO=0 -> input); this signal is used to indicate the black level clamping period for the analog input interface. The beginning and end of its HIGH period (only in the output mode) can be programmed via the I <sup>2</sup> C-bus register 03h, 04h in 50 Hz mode and registers 16h, 17h in 60 Hz mode, active HIGH.
37	HSY	I/O	HORIZONTAL SYNC indicator signal I/O (programmable via IIC-bit PULIO, PULIO=1 -> output, PULIO=0 -> input); is used to indicate the sync tip part of the CVBS input signal for gain control purposes. This signal is fed to the analog interface. The beginning and end of its HIGH period (only in the output mode) can be programmed via the I <sup>2</sup> C-bus register 01h, 02h in 50 Hz mode and registers 14h, 15h in 60 Hz mode, active HIGH.

## One Chip Frontend 1 (OFC1)

SAA7110

TABLE 1. PINNING

PIN NO.	SYMBOL	I O P	DESCRIPTION
38	HS	O	HORIZONTAL SYNC output signal (programmable; the high period is 128 LLC clock cycles. The position of the positive slope is programmable in 8 LLC increments over a complete line (= 64 us) via I <sup>2</sup> C-bus register 05h (50 Hz mode) or 18h (60 Hz mode).
39	PLIN (HL)	O	PAL IDENTIFIER NOT output signal; marks for demodulated PAL signals the inverted line (PLIN=LOW) and a non inverted line (PLIN=HIGH) and for demodulated SECAM signals the DR line (PLIN=LOW) and the DB line (PLIN=HIGH). Select PLIN function via IIC-bit RTSE=0. (H-PLL LOCKED output signal; a HIGH state indicates that the internal PLL has locked; select HL function via I <sup>2</sup> C-bit RTSE=1).
40	ODD (VL)	O	ODD/EVEN field identification (output); a HIGH state indicates the odd field. Select ODD function via IIC-bit RTSE=0. (VERTICAL LOCKED output signal; a HIGH state indicates that the internal VNL is in a locked state; select VL function via I <sup>2</sup> C-bit RTSE=1).
41	VS	I/O	VERTICAL SYNC signal I/O (programmable via IIC-bit OEHV, OEHV=1 -> output, OEHV=0 -> input); this signal indicates the vertical sync with respect to the YUV output. The high period of this signal is approximate six lines if the vertical noise limiter (VNL) function is active. The positive slope contains the phase information for a deflection controller, e.g. TDA9150. In input mode, this signal is used to synchronize the vertical gain- and clamp-blanking stage, active HIGH.
42	HREF	O	HORIZONTAL REFERENCE output signal; this signal is used to indicate data on the digital YUV bus. The positive slope marks the beginning of a new active line. The HIGH period of HREF is either 768 Y samples or 640 Y samples long depending on the detected field frequency (50/60 Hz-mode). HREF is used to synchronize data multiplexer / demultiplexers. HREF is also present during the vertical blanking interval.
43	V <sub>SS3</sub>	P	ground
44	V <sub>DD3</sub>	P	positive supply voltage (+ 5 V)
45-50	Y (7-2)	O	Digital Y (luminance) output signal; higher 6 bits of the 8-bit luminance output signal as part of the digital YUV bus (data rate LLC/2), or A/D2(3) output (data rate LLC/2) selectable via IIC-bit SQPB=1.
51	V <sub>SS2</sub>	P	ground
52	V <sub>DD2</sub>	P	positive supply voltage (+ 5 V)
53-54	Y (1-0)	O	Digital Y (luminance) output signal; lower 2 bits of the 8-bit luminance output signal as part of the digital YUV bus (data rate LLC/2), or A/D2(3) output (data rate LLC/2) selectable via IIC-bit SQPB=1
55-62	UV (7-0)	O	Digital UV (color difference) output signal; multiplexed color difference signal for U and V component of demodulated CVBS or Chroma signal. The format and multiplexing scheme can be selected via I <sup>2</sup> C-bus control. These signals are part of the digital YUV bus (data rate LLC/4), or A/D3(2) output (data rate LLC/2) selectable via IIC-bit SQPB=1
63	FEIN (MUXC)	I	FAST ENABLE INPUT signal (active LOW); this signal is used to control fast switching on the digital YUV bus. A HIGH at this input forces the IC to set its Y and UV outputs to the high impedance state. (Set IIC-bits MS24 and MS34 and MUYC to LOW to use the FEIN function). (MULTIPLEX COMPONENTS (input signal); control signal for the analog multiplexers for fast switching between locked Y/C signals or locked CVBS signals. FEIN automatically fixed to LOW (Digital YUV bus enabled), if one of the three MUXC functions are selected (MS24 or MS34 or MUYC = HIGH)



One Chip Frontend 1 (OFC1)

SAA7110

TABLE 1. PINNING

PIN NO.	SYMBOL	I O P	DESCRIPTION
64	GPSW (VBLK)	O	GENERAL PURPOSE SWITCH (output signal); the state of this signal is programmable via I <sup>2</sup> C-bus register 0Dh, bit 1; select GPSW function via IIC-bit VBLKA =0. (Vertical BLAnK test output; select VBLK function via IIC-bit VBLKA =1)
65	XTAL	O	26.8 MHz crystal oscillator output; not connected if TTL clock signal is used
66	XTALI	I	Input terminal for 26.8 MHz crystal oscillator or connection of external oscillator with TTL compatible square wave clock signal.
67	V <sub>SS1</sub>	P	ground
68	V <sub>DD1</sub>	P	positive supply voltage (+ 5 V)

FIGURE 3. PINNING OCF1-SAA7110

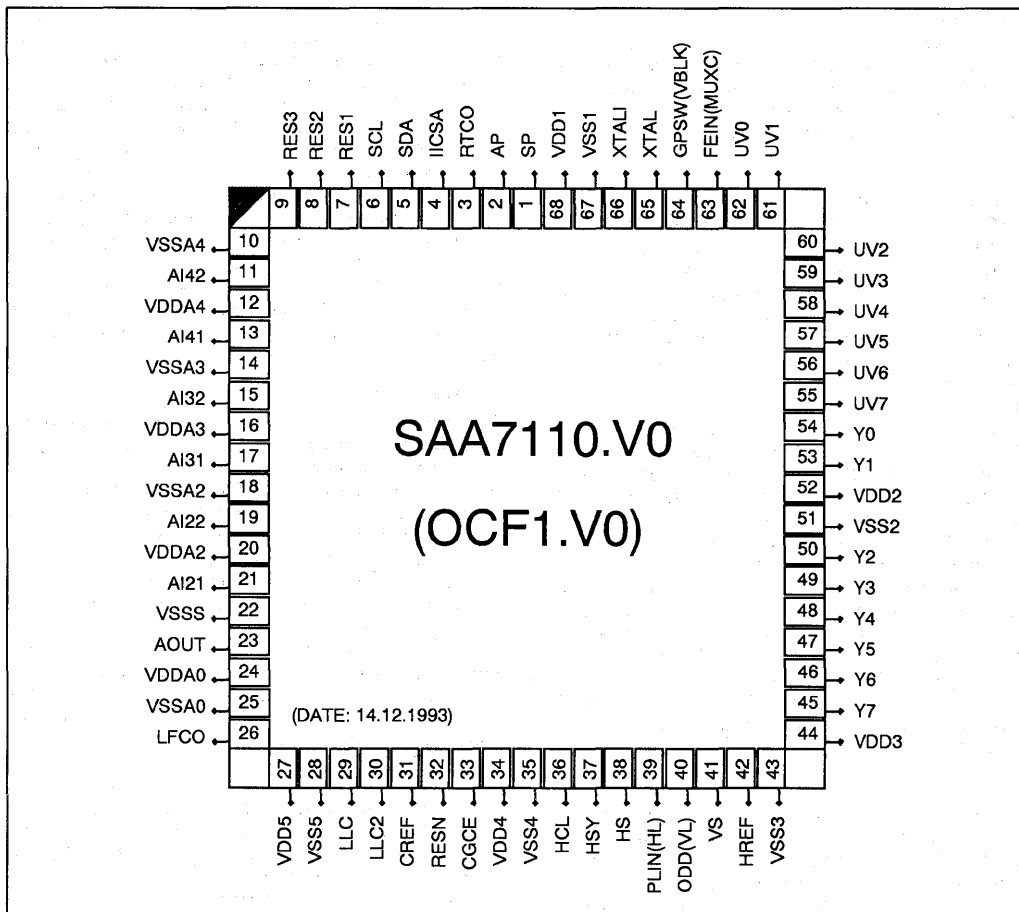

# One Chip Frontend 1 (OFC1)

# SAA7110

## 4. FUNCTIONAL DESCRIPTION

### ANALOG INPUT PROCESSING

The OFC1 offers six analog signal inputs, two analog main channels with clamp circuit, analog amplifier, anti alias filter, and video CMOS ADC. A third analog channel also with clamp circuit, analog amplifier, anti alias filter can be added or switched to both main channels directly before the ADCs.

### ANALOG CONTROL CIRCUITS

The clamp control circuit controls the proper clamping of the analog input signals. The coupling capacitor is also used to storage and filter the clamping voltage. The normal digital clamping level for luminance or CVBS signals is 64 and for chrominance signals 128.

The gain control circuits generate via I<sup>2</sup>C the static gain levels for the three analog amplifiers or controls one of these amplifiers automatically via a build in Automatic Gain Control AGC. The AGC is only used to amplify a CVBS or Y signal to the required signal amplitude, matched to the ADCs input voltage range.

The anti alias filters are adapted to the clock frequency.

The vertical blanking control circuit generates a I<sup>2</sup>C programmable vertical blanking pulse. During the vertical blanking time gain and clamping control were frozen.

The fast switch control circuit is used for special applications.

### CHROMINANCE PROCESSING

The 8-bit chrominance signal passes the input interface, the chrominance bandpass filter to eliminate DC components, and is finally fed to the multiplication inputs of a quadrature demodulator, where two subcarrier signals from the local oscillator (DTO1) with 90 degree phase shift are applied. The frequency is dependent on the present colour standard.

The multiplier operates as a quadrature demodulator for all PAL and NTSC signals; it operates as a frequency down mixer for SECAM signals.

The two multiplier output signals are converted to a serial UV data stream and applied to two lowpass filter stages, then to a gain controlled amplifier. A final multiplexed lowpass filter achieves, together with the preceding stages, the required bandwidth performance.

The from PAL and NTSC originated signal are applied to a comb filter.

The signal, originated from SECAM is fed through a cloche-filter (0 Hz center frequency), a phase demodulator and a differentiator to obtain frequency- demodulated colour-difference signals. The SECAM signal is fed after de-emphasis to a cross-over switch, to provide the both serial-transmitted colour-difference signals. These signals are fed to the BCS control and finally to the output formatter stage and to the output interface.

### LUMINANCE PROCESSING

The 8-bit luminance signal, a digital CVBS format or a luminance format (S-VHS, Hi8), is fed through a switchable pre-filter. High frequency components are emphasized to compensate for loss. The following chrominance trap filter ( $f_0 = 4.43 \text{ MHz}$  or  $f_0 = 3.58 \text{ MHz}$  center frequency selectable)

eliminates most of the colour carrier signal, therefore, it must be by-passed for S-Video (S-VHS, Hi8) signals.

The high frequency components of the luminance signal can be "peaked" (control for sharpness improvement via I<sup>2</sup>C bus) in two bandpass filters with selectable transfer characteristic.

A coring circuit with selectable characteristic improves the signal once more, this signal is then added to the original ('unpeaked') signal. A switchable amplifier achieves a common DC amplification, because the DC gains are different in both chrominance trap modes.

The improved luminance signal is fed via the variable delay compensation to the BCS-control and the output interface.

### YUV-BUS, DIGITAL OUTPUTS

The 16-bit YUV-bus transfers digital data from the output interfaces to a feature box, or a field memory, a digital colour space converter (SAA 7192 DCSC) or a Video enhancement and D/A processor (SAA7165 VEDA2). The outputs are controlled via the I<sup>2</sup>C bus in normal selections, or they are controlled by an output enable chain (FEIN on pin 63).

The YUV data rate equals LLC2. Timing is achieved by marking each second positive rising edge of the clock LLC in conjunction with CREF (clock reference).

The output signals Y7 to Y0 are the bits of the digital luminance signal. The output signals UV7 to UV0 are the bits of the multiplexed colour difference signals (B-Y) and (R-Y). The frame in the format tables is the time, required to transfer a full set of samples. In case of 4:2:2 format two luminance samples are transmitted in comparison to one U and one V sample within the frame. The time frames are controlled by the HREF signal.

Fast enable is achieved by setting input FEIN to LOW. The signal is used to control fast switching on the digital YUV-bus. High on this pin forces the Y and UV outputs to a high-impedance state.

### SYNCHRONIZATION

The prefiltered luminance signal is fed to the synchronization stage. Its bandwidth is reduced to 1 MHz in a low-pass filter. The sync pulses are sliced and fed to the phase detectors to be compared with the sub-divided clock frequency.

The resulting output signal is applied to the loop filter to accumulate all phase deviations. Adjustable output signals (e.g. HCL and HSY) are generated according to analog frontend requirements. The output signals HS, VS, and PLIN are locked to the timing reference guaranteed between the input signal and the HREF signal as further improvements to the circuit may change the total processing delay. It is therefore not recommended to use them for applications, which ask for absolute timing accuracy to the input signals. The loop filter signal drives an oscillator to generate the line frequency control output signal LFCO.

### CLOCK GENERATION CIRCUIT

The internal CGC generates all clock signals required in the one chip frontend. The output signal LFCO is a digital-to-analog converted signal provided by the horizontal PLL. It is the multiple of the line frequency:

$$7.38 \text{ MHz} = 472 \times f_{\text{H}} \text{ in } 50 \text{ Hz systems}$$

---

## One Chip Frontend 1 (OCF1)

## SAA7110

---

### 6.14 MHz = $360 \times f_{\mu}$ in 60 Hz systems

Internally the LFCO signal is multiplied by factors 2 or 4 in the PLL circuit (including phase detector, loop filtering, VCO and frequency divider) to get the LLC and LLC2 output clock signals. The rectangular output clocks have a 50% duty factor.

It's also possible to operate the OCF1 with an external CGC (SAA7197) providing the signals LLC and CREF for the OCF1. The selection of the intern/external CGC will be controlled by the CGCE input signal.

### POWER-ON RESET

Power-on reset is activated at power-on (only using internal CGC), when the supply voltage decreases below 3.5 V. The indicator output RESN is LOW for a time. The RESN signal can be applied to reset other circuits of the digital TV system.

### RTCO OUTPUT

This real time control and status output signal contains serial information about actual system clock, subcarrier frequency and PAL/SECAM sequence. The signal can be used for various applications in external circuits, e. g. in a digital encoder to achieve "clean" encoding.

# One Chip Frontend 1 (OFC1)

SAA7110

FIGURE 4. BLOCK PICTURE Analog Input and Analog Control Part

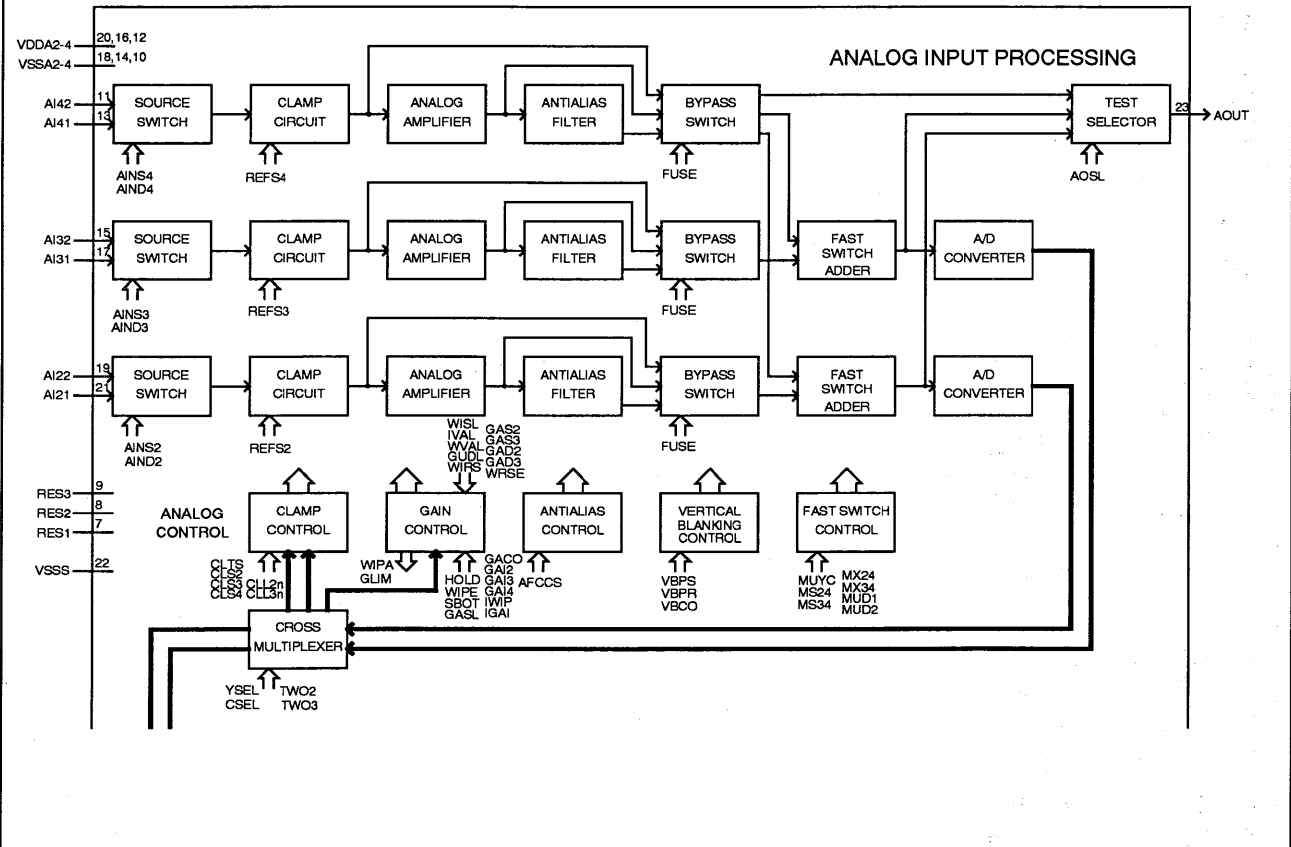

# One Chip Frontend 1 (OFC1)

SAA7110

FIGURE 5. BLOCK PICTURE Multi-Standard Decoder Part

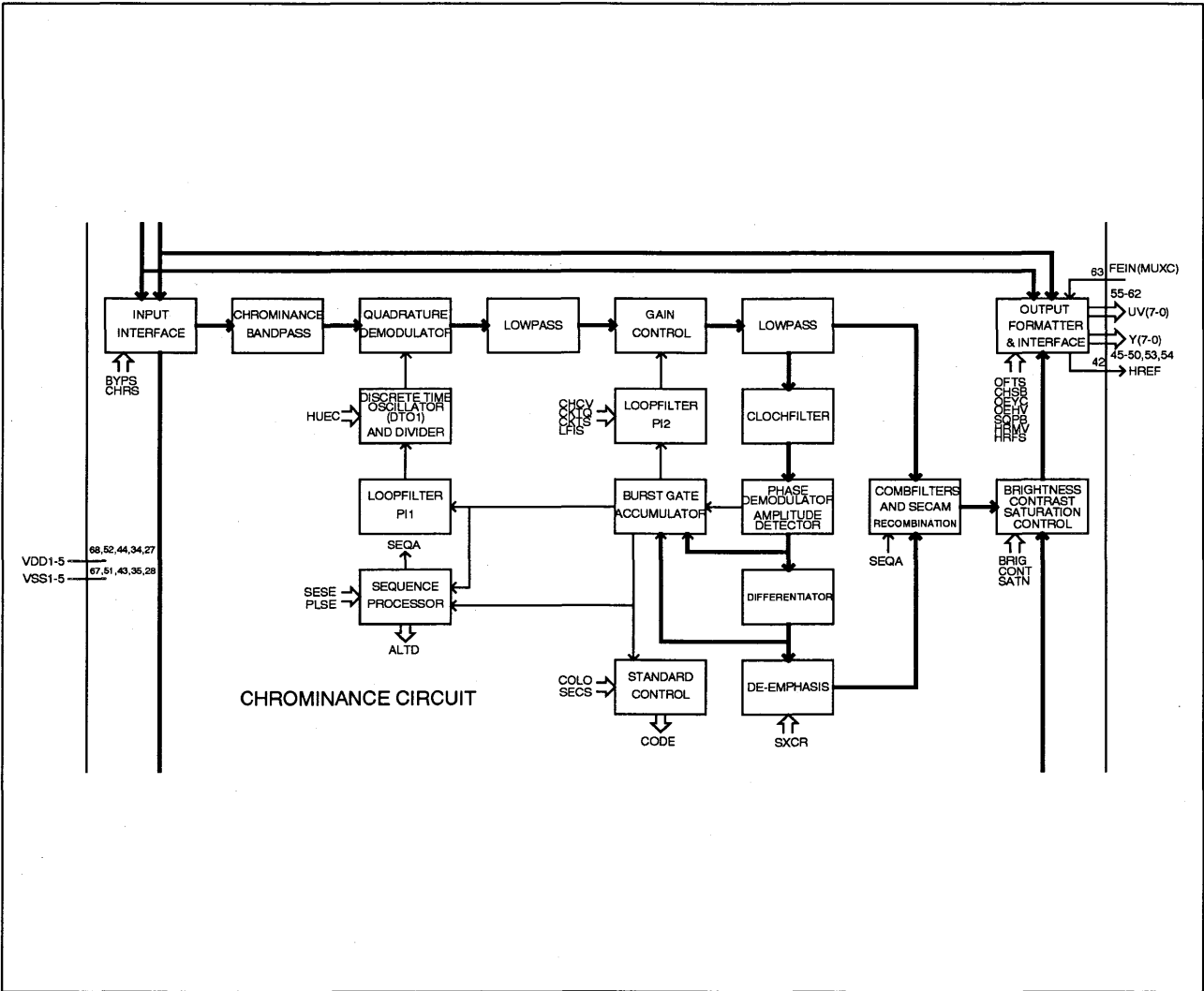

# One Chip Frontend 1 (OFC1)

# SAA7110

FIGURE 6. BLOCK PICTURE Luminance and Synchronization Part

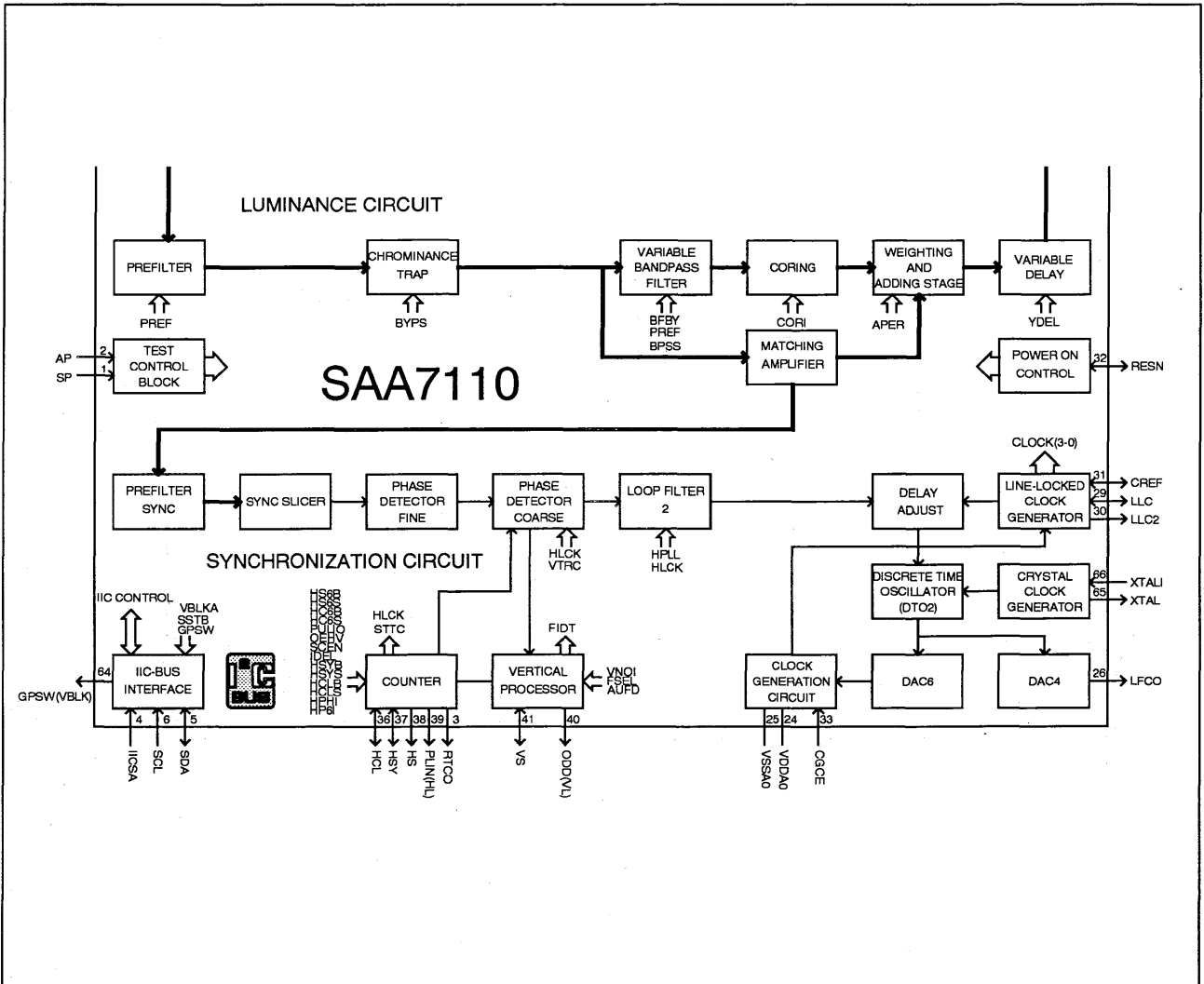

# One Chip Frontend 1 (OFC1)

# SAA7110

## 5. CLAMP AND GAIN DESCRIPTION

### CLAMPING

The coupling capacitance is used as clamp capacitance for each input. An internal digital clamp comparator generates the information about clamp-up or clamp-down. The clamping levels for the two A/D channels are adjustable over the 8-bit range (1 to 254). Clamping time in normal use is set with the HCL pulse at the back porch of the video signal. The clamping pulse HCL is user adjustable.

### GAIN CONTROL

The luminance AGC can be used for every channel were luminance or CVBS is coming in. AGC active time is the sync tip of the video signal. The sync tip pulse HSY is user adjustable. The AGC can be switched off and the gain for the three main input channels can be adjusted independently. Signal (white) peak control limits the gain at signal overshoots. The flow charts on this page and on the next page show more details of the AGC. The influence of supply voltage variation within the specified range is automatically eliminated by clamp and automatic gain control.

FIGURE 7. AUTOMATIC GAIN CONTROL RANGE

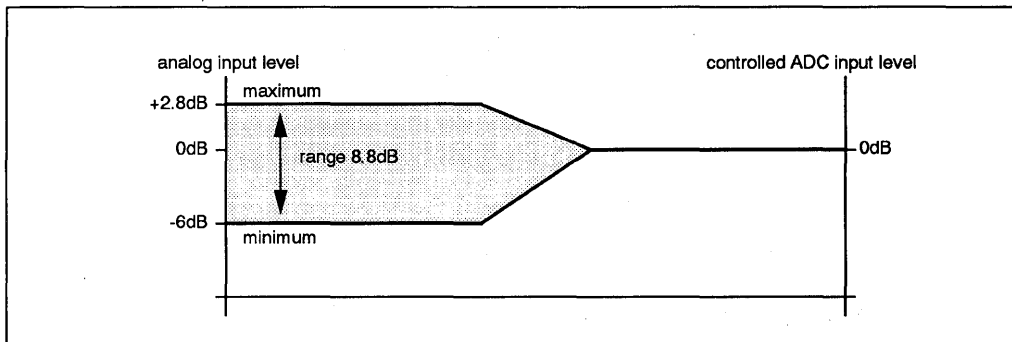
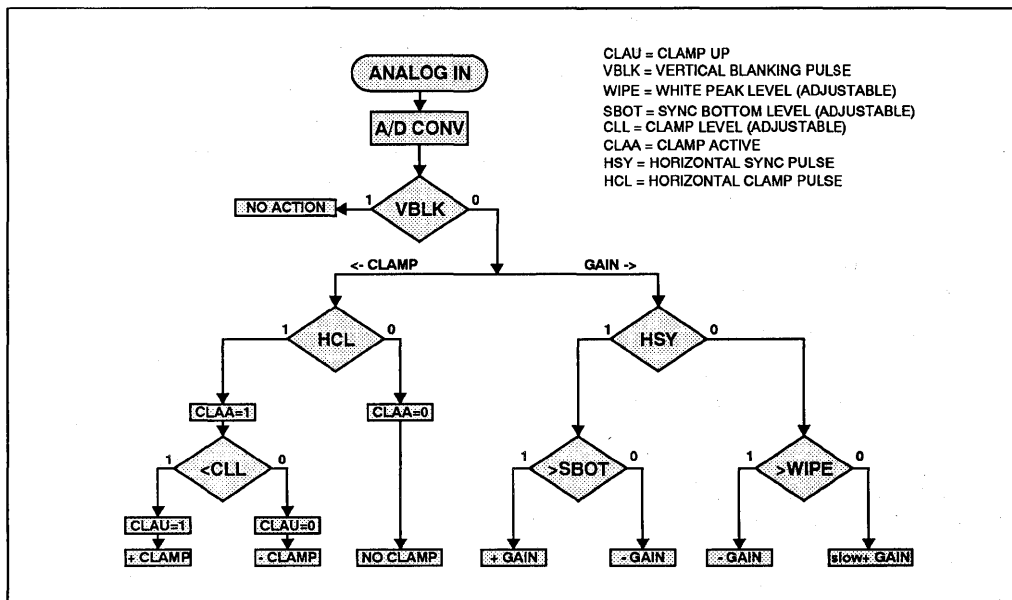

FIGURE 8. CLAMP AND GAIN FLOWCHART



One Chip Frontend 1 (OFC1)

SAA7110

FIGURE 9. LUMINANCE AGC FLOWCHART

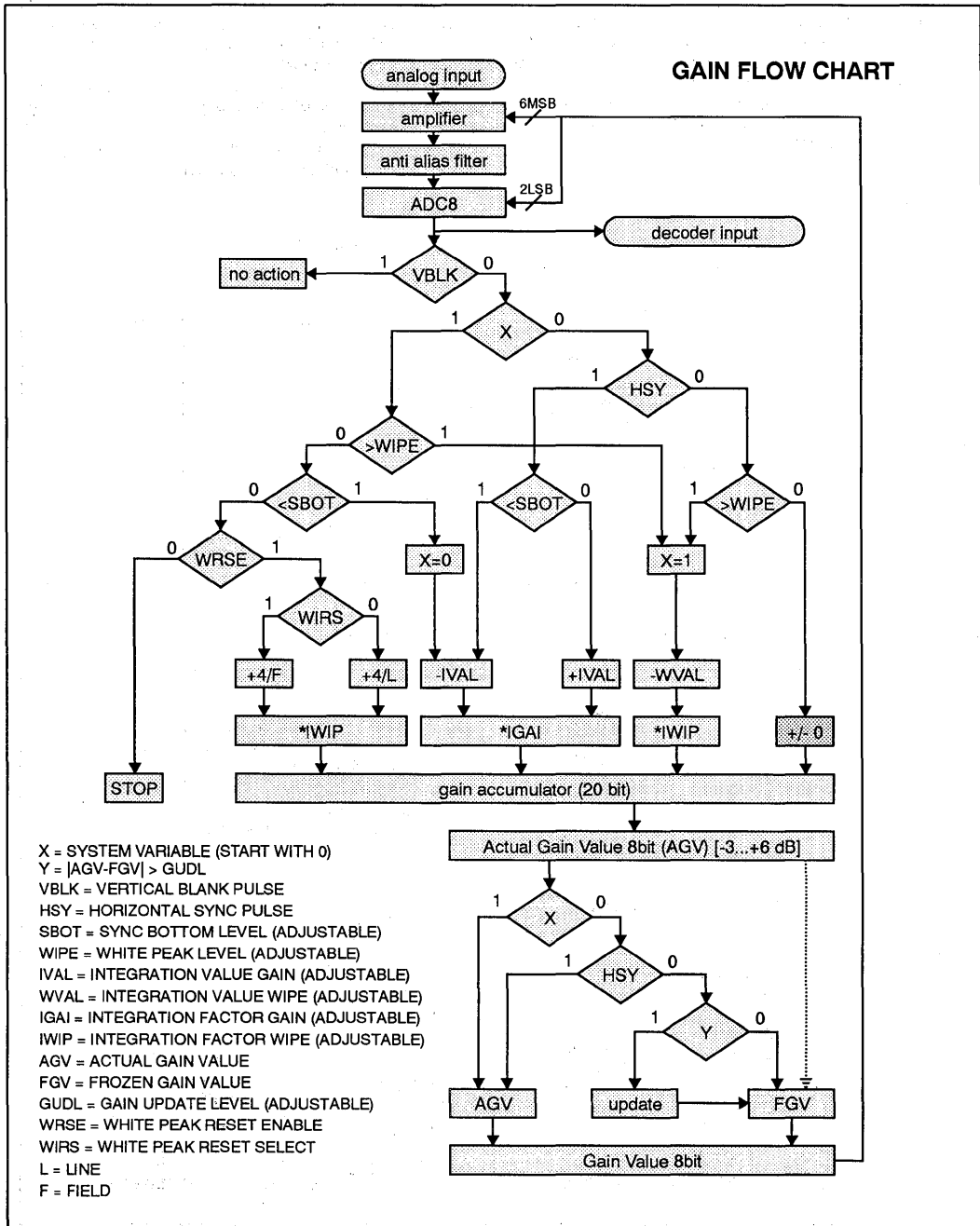



## One Chip Frontend 1 (OFC1)

SAA7110

## 6. LIMITING VALUES

In accordance with the Absolute Maximum Rating System (IEC 134); all ground pins as well as all supply pins connected together.

TABLE 2. LIMITING VALUES

SYMBOL	PARAMETER	MIN	MAX	UNIT
$T_{stg}$	Storage temperature	-65	+150	°C
$t_{amb}$	Temperature under bias	-10	+80	°C
$T_{amb}$	Operating ambient temperature range	0	+70	°C
$V_{DD}$	Supply voltage digital	-0.5	+7.0	V
$V_{DDA}$	Supply voltage analog	-0.5	+7.0	V
$V_I$	Input voltage digital	-0.5	+7.0	V
$V_I$	Input voltage analog	-0.5	+7.0	V
$V_{diffGND}$	Difference voltage $V_{SSAall} - V_{SSall}$	-	100	mV
$V_{ESD}$	Electrostatic * handling for all pins	-	±2000	V
$P_{tot}$	total power dissipation	-	2.5	W
* Equivalent to discharging a 100pF capacitor through an 1.5kΩ series resistor				

## 7. ELECTRICAL CHARACTERISTICS

TABLE 3. ELECTRICAL CHARACTERISTICS

SYMBOL	PARAMETER	TEST CONDITIONS	MIN	LIMITS TYP	MAX	UNIT
<b>Supply</b>						
$V_{DD1-5}$	digital supply voltage range		4.5	5	5.5	V
$I_{DD1-5}$	digital total supply current		-	-	250	mA
$V_{DDA0,2-4}$	analog supply voltage range		4.75	5	5.25	V
$I_{DDA0,2-4}$	analog total supply current		-	-	150	mA
<b>Analog part</b>						
$I_{clamp}$	clamp current	$V_I=1.25V_{DC}$	-	±2	-	μA
$V_{i(pp)}$	input voltage (AC coupling necessary)	$C_{coup}=10nF$	0.5	1	1.38	$V_{pp}$
$ Z_i $	input impedance	$I_{clamp}$ off	200	-	-	kΩ
$C_i$	input capacitance		-	-	10	pF
a	channel crosstalk	$f < 5MHz$	-	-50	-	dB
$f_{2.5(max)}$	maximal harmonic distortion (Input signal: near full scale sinus)	at 4.0MHz, gain=0dB, AAF=on	-	t.b.d.	-	dB
S/N ( $f \approx f_6$ )	signal-to-noise ratio (Input signal: near full scale sinus)	at 4.0MHz, gain=0dB, AAF=on	-	t.b.d.	-	dB

## One Chip Frontend 1 (OFC1)

## SAA7110

TABLE 3. ELECTRICAL CHARACTERISTICS

SYMBOL	PARAMETER	TEST CONDITIONS	MIN	LIMITS TYP	MAX	UNIT
<b>ADCs</b>						
B	analog bandwidth	-3dB	-	15	-	MHz
$\Phi_{diff}$	differential phase (Amplifier and AAF=bypass)		-	2	-	deg
$G_{diff}$	differential gain (Amplifier and AAF=bypass)		-	2	-	%
$f_{LLC}$	clock rate ADC		11	-	16	MHz
DLE	DC differential linearity error		-	1/2	-	LSB
ILE	DC integral linearity error		-	1	-	LSB
<b>Digital inputs</b>						
$V_{IL,IIC}$	input voltage LOW	SDA and SCL	-0.5	-	1.5	V
$V_{IH,IIC}$	input voltage HIGH	SDA and SCL	3.0	-	$V_{DD}+0.5$	V
$V_{IL,clocks}$	input voltage LOW	clocks	-0.5	-	0.6	V
$V_{IH,LLC}$	input voltage HIGH		2.4	-	$V_{DD}+0.5$	V
$V_{IH,XTALI}$	input voltage HIGH		3.0	-	$V_{DD}+0.5$	V
$V_{IL}$	input voltage LOW	other inputs	-0.5	-	0.8	V
$V_{IH}$	input voltage HIGH	other inputs	2.0	-	$V_{DD}+0.5$	V
$I_{LI}$	input leakage current		-	-	10	mA
$C_{I,LLC}$	input capacitance	clocks	-	-	10	pF
$C_I$	input capacitance	other inputs	-	-	8	pF
$C_{I,IO}$	input capacitance	I/O at high impedance	-	-	8	pF
<b>Digital outputs</b>						
$V_{LFCO}$	output amplitude of LFCO (peak-to-peak value)	note 1	1.4	-	2.6	V
$V_{OL}$	output voltage LOW	note 2	0	-	0.6	V
$V_{OH}$	output voltage HIGH	note 2	2.4	-	$V_{DD}$	V
$V_{OL,clocks}$	output voltage LOW	clocks	-0.5	-	0.6	V
$V_{OH,clocks}$	output voltage HIGH	clocks	2.6	-	$V_{DD}+0.5$	V
<b>Clock input timing (LLC)</b>						
$t_{LLC}$	cycle time LLC		31	-	45	ns
$\delta$	duty factor: $t_{LLCH}/t_{LLC}$		40	-	60	%
$t_{r,LLC}$	rise time	0.6V to 2.4V	-	-	5	ns
$t_{f,LLC}$	fall time	2.4V to 0.6V	-	-	5	ns
<b>Control and CREF input timing (note 5)</b>						
$t_{SU}$	input data set-up time		11	-	-	ns
$t_{HD,CREF}$	input data hold-time		3	-	-	ns

One Chip Frontend 1 (OFC1)

SAA7110

TABLE 3. ELECTRICAL CHARACTERISTICS

SYMBOL	PARAMETER	TEST CONDITIONS	MIN	LIMITS TYP	MAX	UNIT
$t_{HD.FEIN}$	input data hold-time		3	-	-	ns
$t_{HD.other}$	input data hold-time	Note 5	6	-	-	ns
<b>Data and control output timing (note 3)</b>						
$C_{L.data}$	output load capacitance (data, HREF and VS)		15	-	50	pF
$C_{L.cont}$	output load capacitance (control)		7.5	-	25	pF
$t_{OH.data}$	output hold time	15 pF	13	-	-	ns
$t_{PD.data}$	propagation delay from negative edge of LLC (data, HREF and VS)	50 pF	-	-	29	ns
$t_{PD.cont}$	propagation delay from negative edge of LLC (control)	25 pF	-	-	29	ns
$t_{PZ}$	propagation delay from negative edge of LLC (to 3-state)	Note 4	-	-	15	ns
<b>Clock output timing (LLC, LLC2)</b>						
$C_{L.LLC}$	output load capacitance		15	-	40	pF
$t_{LLC}$	cycle time LLC		31.5	-	45	ns
$t_{LLC2}$	cycle time LLC2		63	-	90	ns
$\delta$	duty factors: $t_{LLCH}/t_{LLC}$ and $t_{LLC2H}/t_{LLC2}$		40	-	60	%
$t_r$	rise time LLC, LLC2	0.6V to 2.6V	-	-	5	ns
$t_f$	fall time LLC, LLC2	2.6V to 0.6V	-	-	5	ns
$t_{dLLC2}$	delay time LLC out to LLC2 out	at 1.5V, 40pF Note 6	-	-	8	ns
<b>Data qualifier output timing (CREF)</b>						
$t_{OH.CREF}$	output hold time	15 pF	4	-	-	ns
$t_{PD.CREF}$	propagation delay from positive edge of LLC	40 pF	-	-	20	ns
<b>Horizontal PLL</b>						
$f_{Hn}$	nominal line frequency	50 Hz field	-	15625	-	Hz
		60 Hz field	-	15734	-	Hz
$Df_H/f_{Hn}$	permissible static deviation	50 Hz field	-	-	5.6	%
		60 Hz field	-	-	6.7	%
<b>Subcarrier PLL</b>						
$f_{Hn}$	nominal subcarrier frequency	PAL	-	4433618	-	Hz
		NTSC	-	3579545	-	Hz
$Df_H/f_{Hn}$	lock in range		400	-	-	Hz

## One Chip Frontend 1 (OFC1)

SAA7110

TABLE 3. ELECTRICAL CHARACTERISTICS

SYMBOL	PARAMETER	TEST CONDITIONS	MIN	LIMITS TYP	MAX	UNIT
<b>Crystal oscillator</b>						
$f_n$	nominal frequency	3rd harmonic	-	26.8	-	Mhz
$Df/f_n$	permissible deviation $f_n$		-	-	$\pm 50$	$10^{-6}$
	temperature deviation		-	-	$\pm 20$	$10^{-6}$
X1	crystal specification:					
	temperature range $T_{amb}$		0	-	70	$^{\circ}\text{C}$
	load capacitance $C_L$		8	-	-	pF
	series resonance resistor $R_S$		-	50	80	$\Omega$
	motional capacitance $C_1$		-	1.1 $\pm 20\%$	-	fF
	parallel capacitance $C_0$		-	3.5 $\pm 20\%$	-	pF
	Philips catalogue number:		9922 520 30004			
<b>Notes to the characteristics:</b>						
1. The LFCO output level must be measured with a load circuit 10k $\Omega$ in parallel to 15pF.						
2. The levels must be measured with load circuits, the loads used depend on the type of output stage. Control outputs (except HREF, VS); 1.2k $\Omega$ at 3V (TTL load), $C_L=25\text{pF}$ : data outputs (and HREF, VS); 1.2k $\Omega$ at 3V (TTL load), $C_L=50\text{pF}$ .						
3. Data output signals are YUV(15-0). Control output signals are HREF, VS, HS, HSY, HCL, RTCO, PLIN(HL), ODD(VL), GPSW0(VBLK). Effects of rise and fall times are included in the calculation of $t_{OH}$ , $t_{PD}$ and $t_{PZ}$ . Timings and levels refer to drawings and conditions shown in Fig.8 on next page.						
4. The minimum propagation delay from 3-state to data active related to falling edge of LLC is 0ns.						
5. Other control input signals are CGCE, VS, IICSA, HCL, HSY.						
6. LLC2 out is not active while CGCE=0						
* Values to be fixed						

One Chip Frontend 1 (OFC1)

SAA7110

8. TIMINGS

FIGURE 10. CLOCK/DATA TIMING

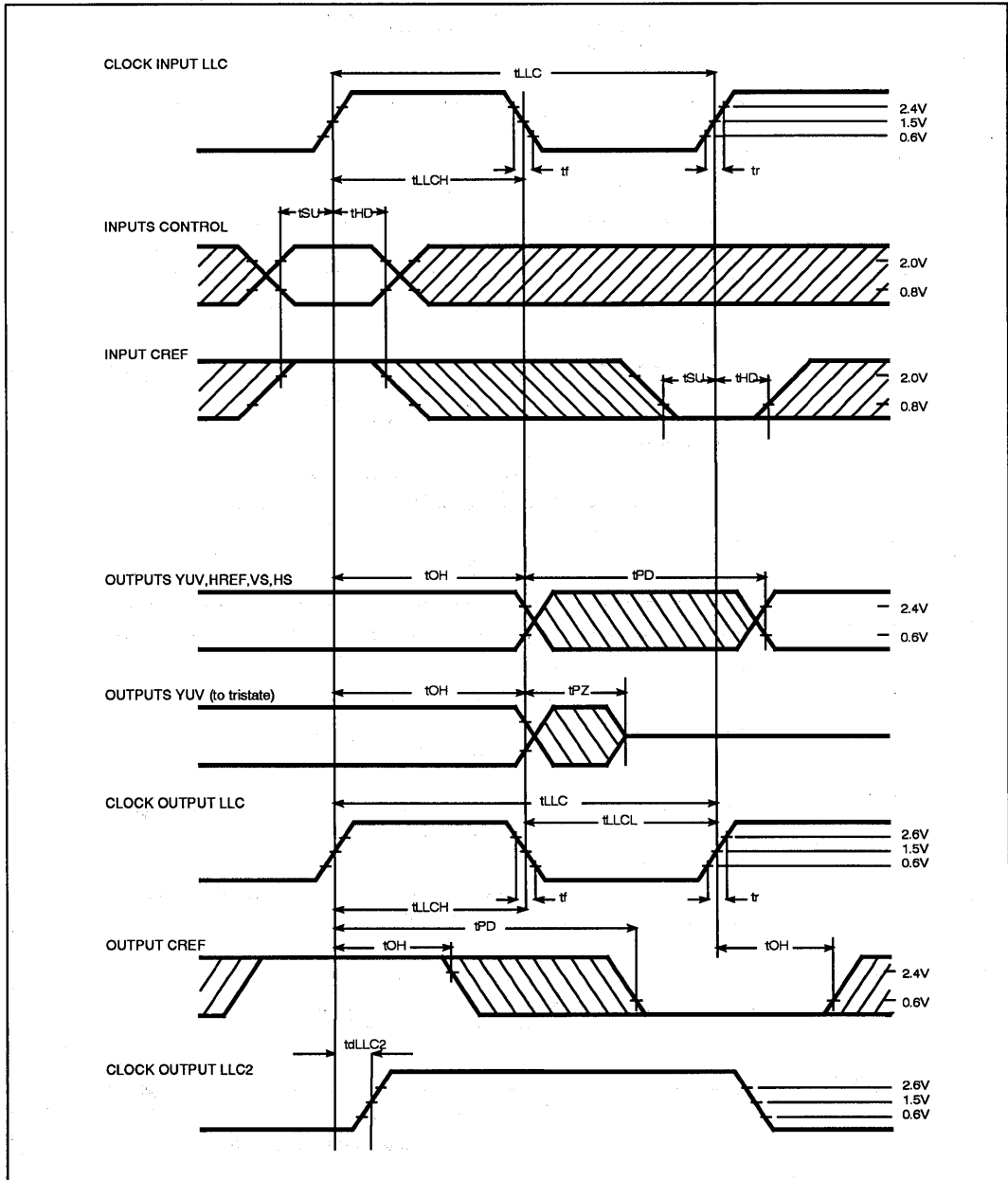

One Chip Frontend 1 (OFC1)

SAA7110

FIGURE 11. HORIZONTAL TIMING

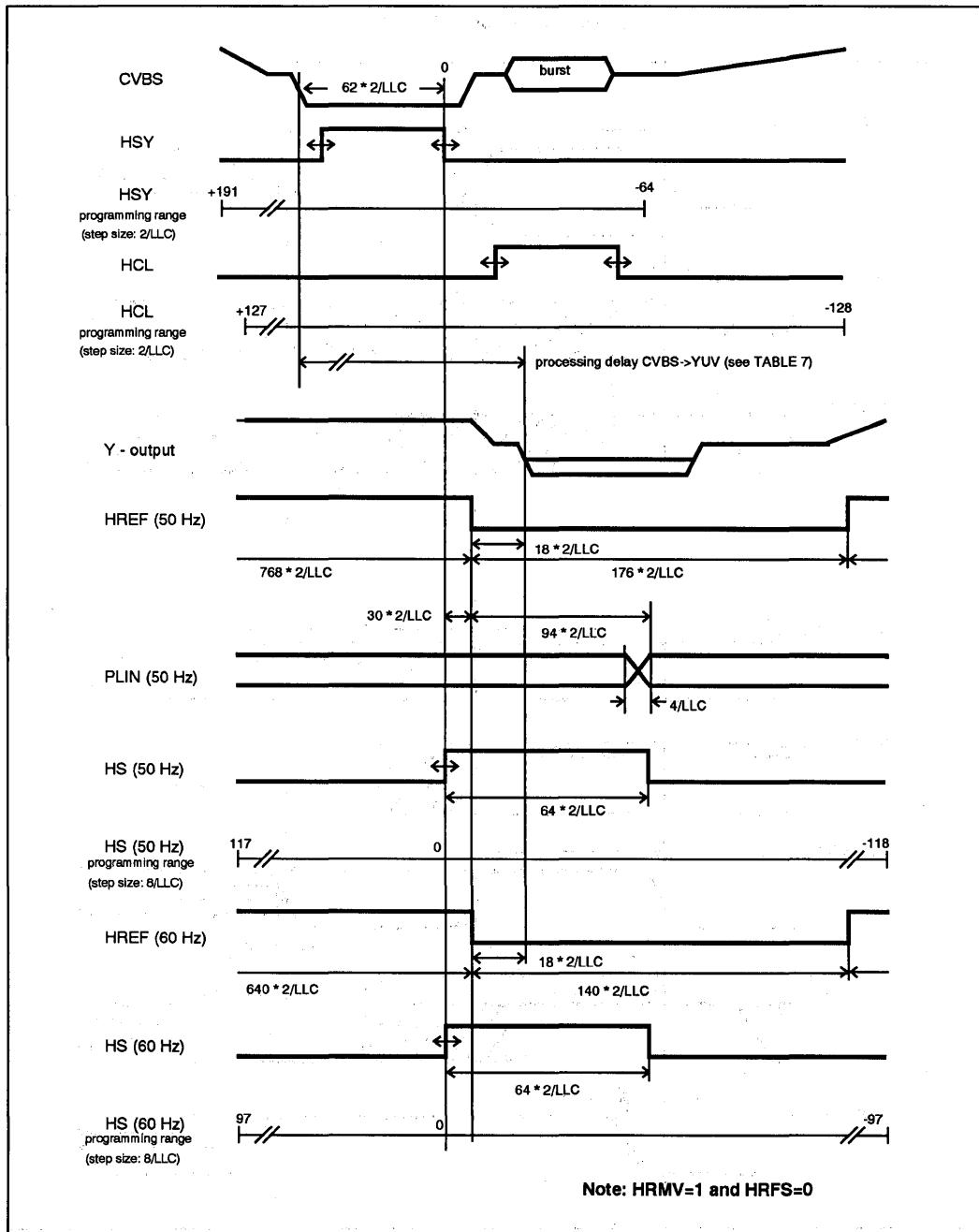

One Chip Frontend 1 (OFC1)

SAA7110

FIGURE 12. HREF TIMING

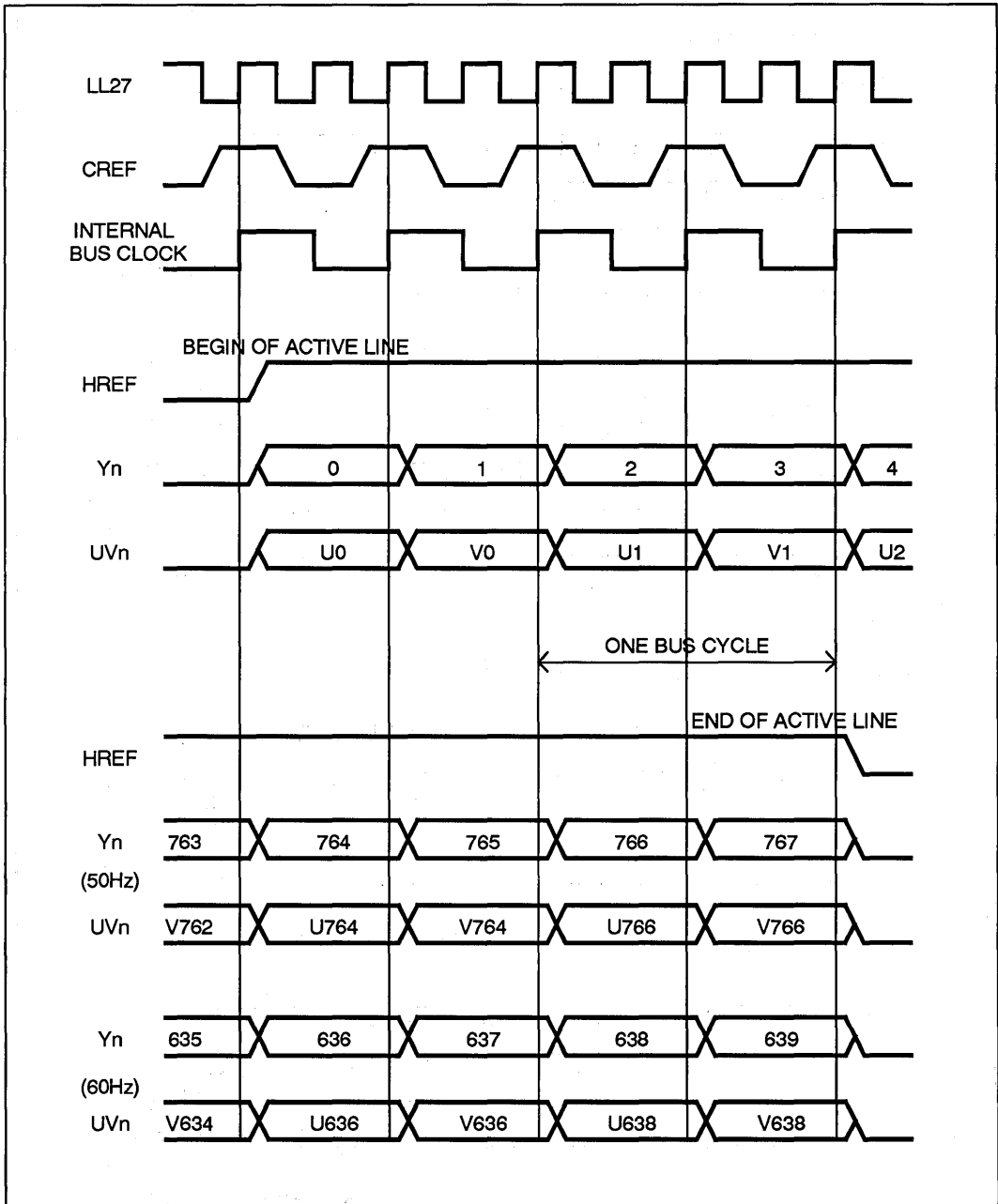

# One Chip Frontend 1 (OFC1)

SAA7110

FIGURE 13. VERTICAL TIMING

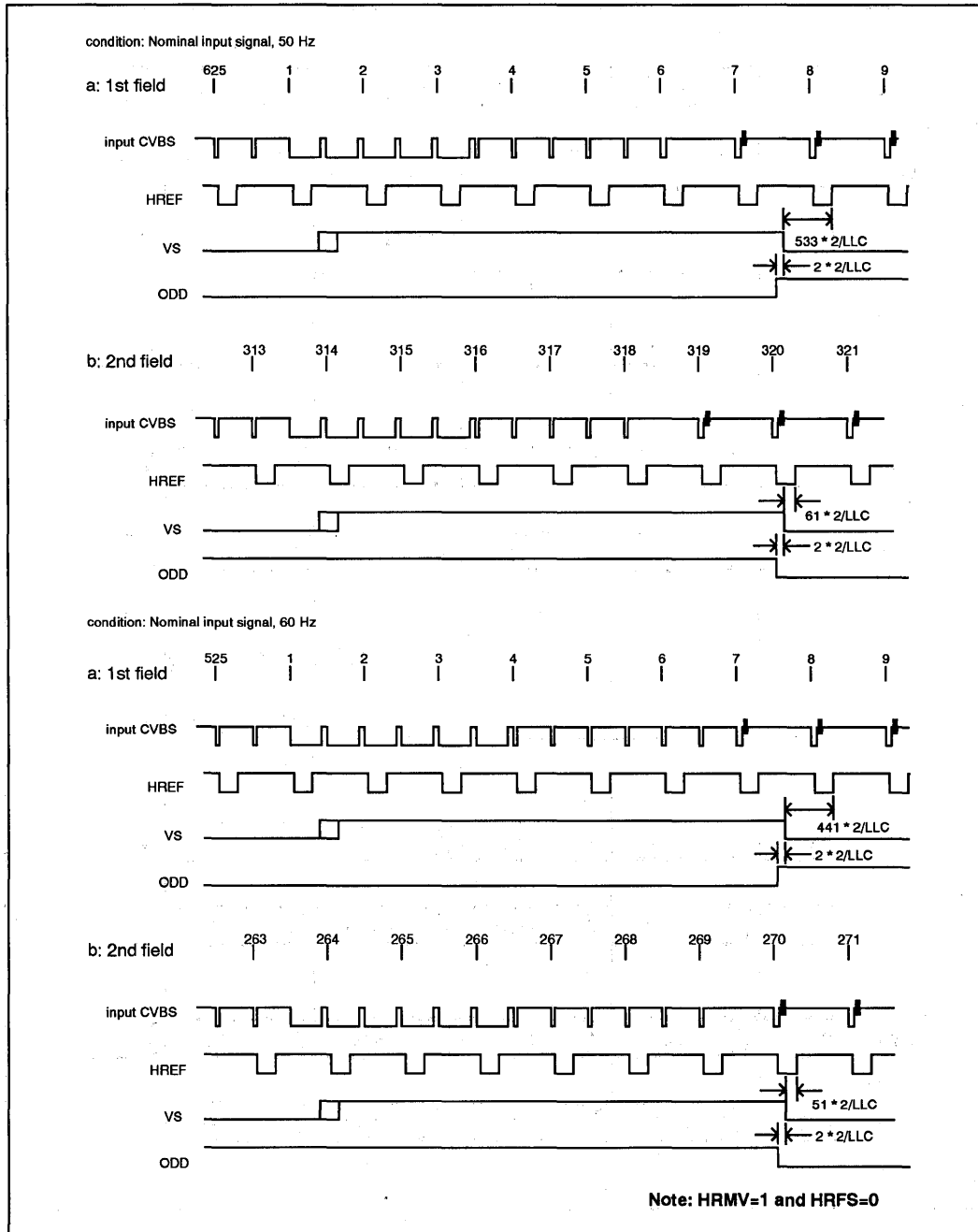



# One Chip Frontend 1 (OFC1)

# SAA7110

## 9. DIGITAL OUTPUT CONTROL

FIGURE 14. FEIN TIMING

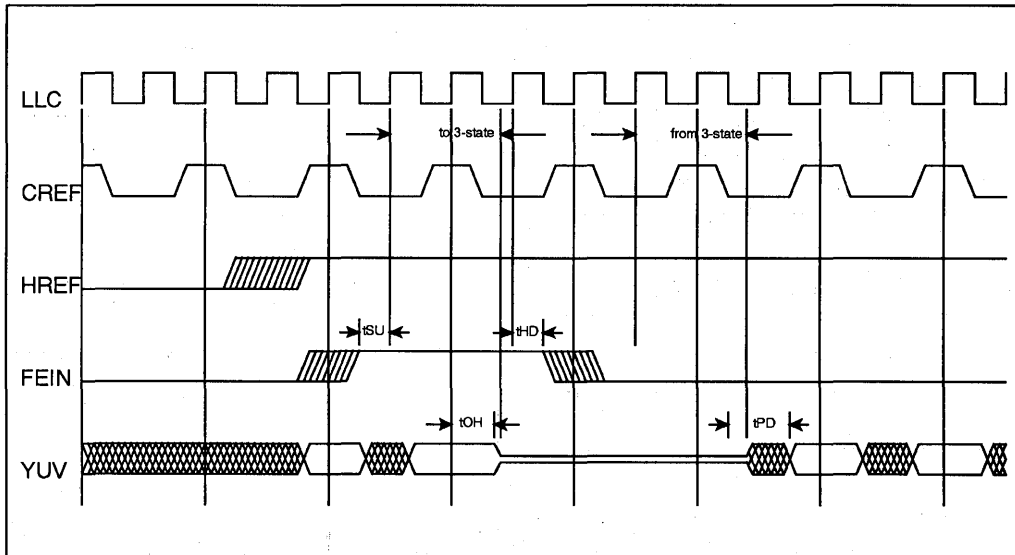
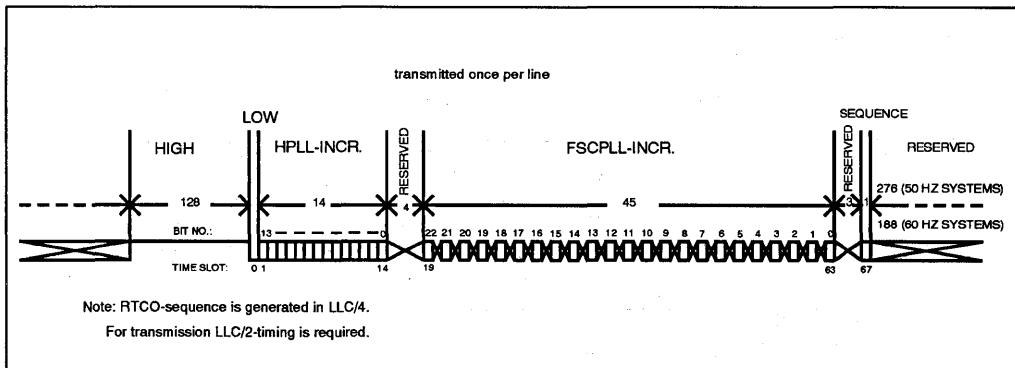

TABLE 4. DIGITAL OUTPUT CONTROL

OEYC	FEIN	YUV(15:0)
0	0	Z
1	0	active
X	1	Z

## 10. REALTIME CONTROL OUTPUT

FIGURE 15. REAL TIME CONTROL OUTPUT



# One Chip Frontend 1 (OFC1)

# SAA7110

## 11. OUTPUT FORMATS

TABLE 5. 4:1:1 FORMAT

BUS SIGNAL	Pixel Byte Sequence							
Y7	Y7	Y7	Y7	Y7	Y7	Y7	Y7	Y7
Y6	Y6	Y6	Y6	Y6	Y6	Y6	Y6	Y6
Y5	Y5	Y5	Y5	Y5	Y5	Y5	Y5	Y5
Y4	Y4	Y4	Y4	Y4	Y4	Y4	Y4	Y4
Y3	Y3	Y3	Y3	Y3	Y3	Y3	Y3	Y3
Y2	Y2	Y2	Y2	Y2	Y2	Y2	Y2	Y2
Y1	Y1	Y1	Y1	Y1	Y1	Y1	Y1	Y1
Y0	Y0	Y0	Y0	Y0	Y0	Y0	Y0	Y0
UV7	U7	U5	U3	U1	U7	U5	U3	U1
UV6	U6	U4	U2	U0	U6	U4	U2	U0
UV5	V7	V5	V3	V1	V7	V5	V3	V1
UV4	V6	V4	V2	V0	V6	V4	V2	V0
UV3	0	0	0	0	0	0	0	0
UV2	0	0	0	0	0	0	0	0
UV1	0	0	0	0	0	0	0	0
UV0	0	0	0	0	0	0	0	0
Y FRAME	0	1	2	3	4	5	6	7
UV FRAME	0			4				
Note:								
	Data rate			Sample frequency				
Y	LLC2			LLC2				
U				LLC4				
V				LLC4				

TABLE 6. 4:2:2 FORMAT

BUS SIGNAL	Pixel Byte Sequence					
Y7	Y7	Y7	Y7	Y7	Y7	Y7
Y6	Y6	Y6	Y6	Y6	Y6	Y6
Y5	Y5	Y5	Y5	Y5	Y5	Y5
Y4	Y4	Y4	Y4	Y4	Y4	Y4
Y3	Y3	Y3	Y3	Y3	Y3	Y3
Y2	Y2	Y2	Y2	Y2	Y2	Y2
Y1	Y1	Y1	Y1	Y1	Y1	Y1
Y0	Y0	Y0	Y0	Y0	Y0	Y0
UV7	U7	V7	U7	V7	U7	V7
UV6	U6	V6	U6	V6	U6	V6
UV5	U5	V5	U5	V5	U5	V5
UV4	U4	V4	U4	V4	U4	V4
UV3	U3	V3	U3	V3	U3	V3
UV2	U2	V2	U2	V2	U2	V2
UV1	U1	V1	U1	V1	U1	V1
UV0	U0	V0	U0	V0	U0	V0
Y FRAME	0	1	2	3	4	5
UV FRAME	0	2	4			
Note:						
	Data rate		Sample frequency			
Y	LLC2		LLC2			
U			LLC8			
V			LLC8			

## 12. PROCESSING DELAY

TABLE 7. PROCESSING DELAY (CVBSIN - YUVOUT)

FUNCTION	ANALOG DELAY (typical) AIN41 -> ADCIN(AOUT) (ns)		DIGITAL DELAY ADCIN(AOUT) -> YUVOUT (1/LLC) [YDEL=0, CAD2/3=1]
	AFCCS=0	AFCCS=1	
without AMP + AAF	20		248
with AMP, without AAF	50		
with AMP + AAF (50Hz)	50+25	50+50	
with AMP + AAF (60Hz)	50+35	50+70	

# One Chip Frontend 1 (OFC1)

# SAA7110

## 13. YUV OUTPUT SIGNAL RANGE

FIGURE 16. YUV OUTPUT SIGNAL RANGE

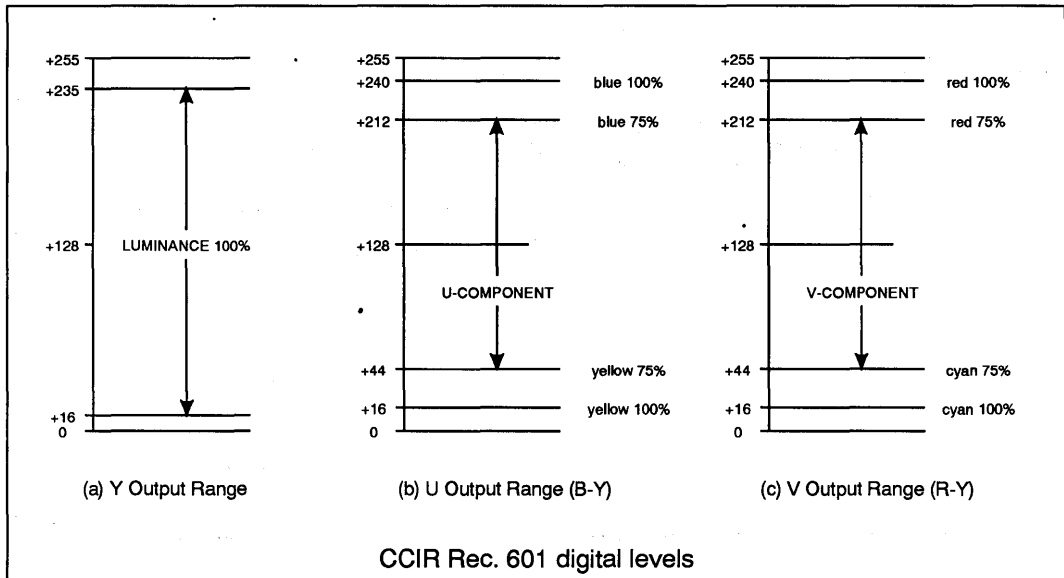

## 14. OSCILLATOR APPLICATION

FIGURE 17. OSCILLATOR APPLICATION

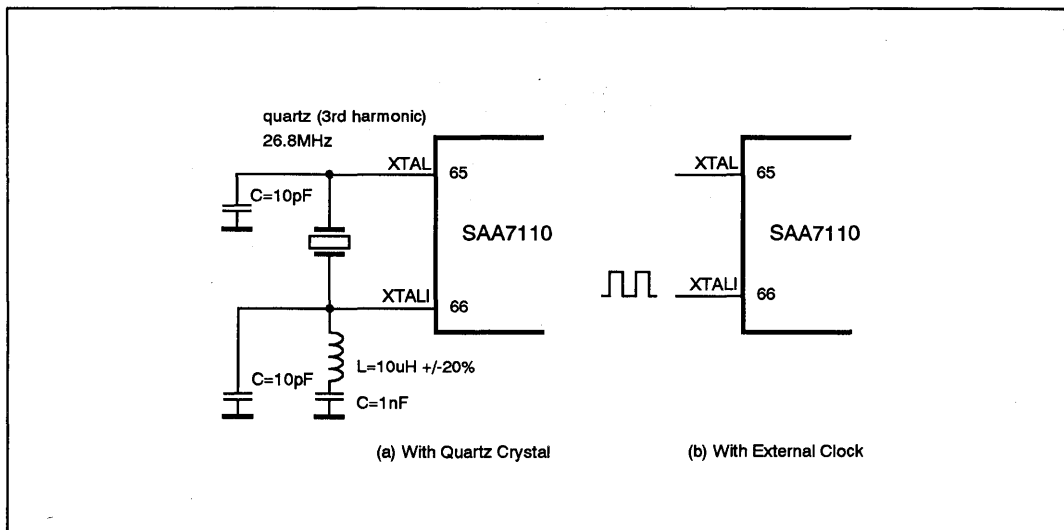

# One Chip Frontend 1 (OFC1)

SAA7110

## 15. CLOCK GENERATION CIRCUIT

The internal CGC generates the system clock LLC, LLC2 and the clock reference signal CREF. The internal generated LFCO (triangular waveform) is multiplied by four via the analog PLL (including phase detector, loop filter, VCO and frequency divider). The rectangular output signals have 50% duty factor.

FIGURE 18. CLOCK GENERATION CIRCUIT

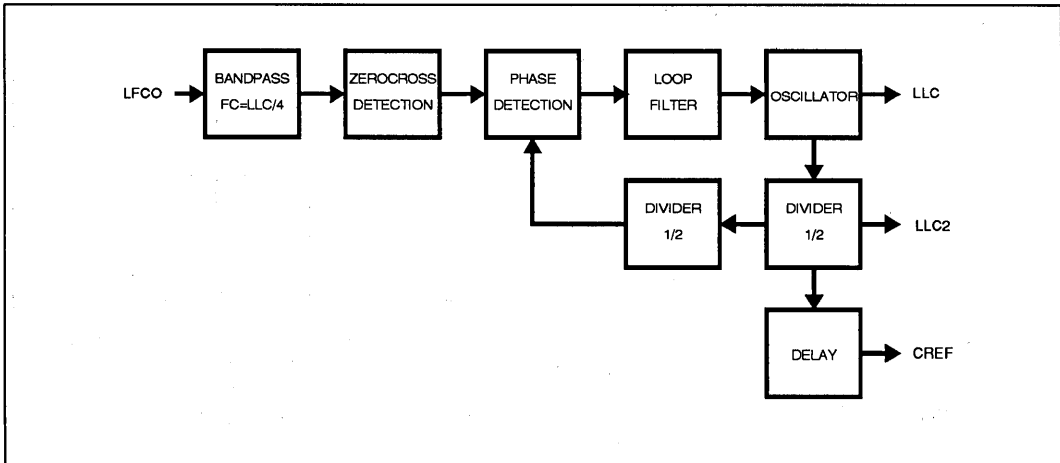

## 16. CLOCK FREQUENCIES

TABLE 8. SYSTEM CLOCK FREQUENCIES (MHZ)

CLOCK	50Hz	60Hz
XTAL	26.8	
LLC	29.5	24.545454
LLC2	14.75	12.272727
LLC4	7.375	6.136136
LLC8	3.6875	3.068181

One Chip Frontend 1 (OFC1)

SAA7110

17. POWER-ON CONTROL

Power-on reset is activated at power-on (only using internal CGC) and if the supply voltage decreases below 3.5 V. The RESN signal can be applied to reset other circuits of the digital TV system.

FIGURE 19. POWER-ON CONTROL

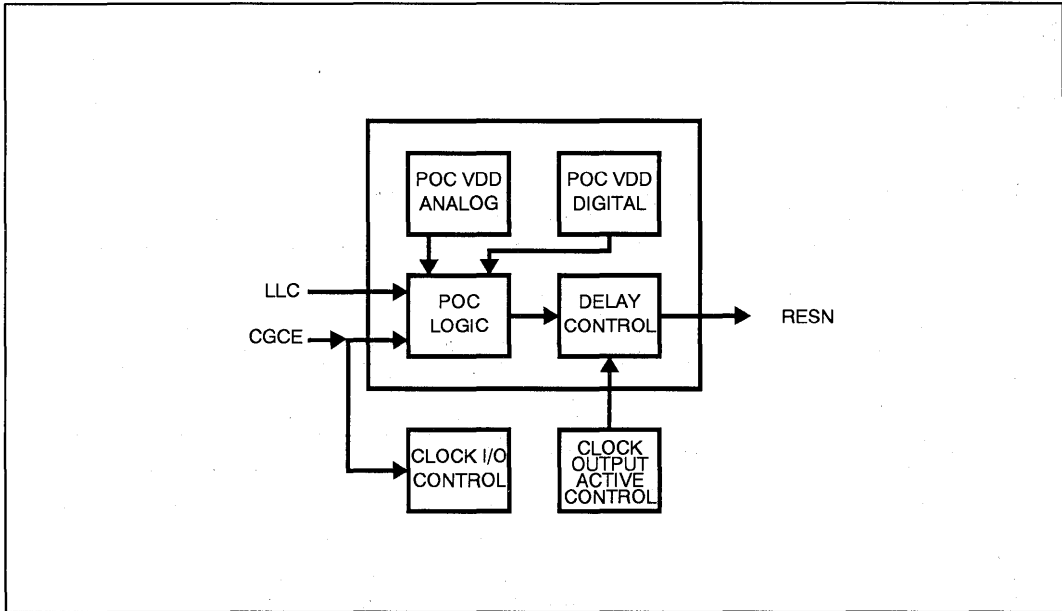

TABLE 9. POWER-ON CONTROL SEQUENCE

INTERNAL POWER ON CONTROL SEQUENCE	PIN OUTPUT STATUS	FUNCTION
DIRECTLY AFTER POWER ON ASYNCHRONOUS RESET	Y(7:0), UV(7:0), RTCO, PLIN, ODD, GPSW, SDA, HREF, HS, VS, HCL, HSY --> high impedance state LLC, LLC2, CREF --> HIGH state	direct switching to high impedance (outputs) or input mode (I/Os) for 20 - 200ms
START SYNCHRONOUS IIC RESET SEQUENCE	LLC, LLC2, CREF became active	<b>starting IIC reset sequence</b>
STATUS after IIC RESET	Y(7:0), UV(7:0), HREF, HS --> held in high impedance state VS, HCL, HSY --> held in input function mode	SA0Dh=7Dh (VTRC=0, RTSE=1, HRMV=1, SSTB=0, SECS=1), SA0Eh=00h (HPLL=0, OEHV=0, OEYC=0, CHR5=0, GPSW1=0), SA31h=00h (AOSL(1:0)=00, WIRS=0, WRSE=0, SQPB=0, AFCCS=0, VBLKA=0, PULIO=0)
STATUS after POWER ON CONTROL SEQUENCE	RTCO, PLIN, ODD, GPSW, SDA active	<b>After power on (reset sequence) a complete IIC transmission is required!</b>

## One Chip Frontend 1 (OFC1)

SAA7110

## 18. IIC DESCRIPTION

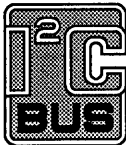

## 19. IIC-BUS FORMAT

TABLE 10. IIC FORMAT

S	SLAVEADDRESS	A	SUBADDRESS	A	DATA (n bytes)*	A	P
---	--------------	---	------------	---	-----------------	---	---

S		start condition					
SLAVEADDRESS	1001 110Xb (IICSA=LOW) or 1001 111Xb (IICSA=HIGH)						
A	acknowledge, generated by the slave						
SUBADDRESS	subaddress byte, see reference table						
DATA	data byte, see reference table						
P	stop condition						
X	read/write control bit X=0, order to write (the circuit is slave receiver) X=1, order to read (the circuit is slave transmitter)						
SLAVEADDRESS	9Ch for write (IICSA=0) 9Dh for read (IICSA=0) 9Eh for write (IICSA=1) 9Fh for read (IICSA=1)						
SUBADDRESSES	00 h - 19h Decoder part 1Ah - 1Fh reserved 20h - 34h Frontend part						
* If more than one byte DATA are transmitted, then auto-increment of the subadress is performed.							

## One Chip Frontend 1 (OFC1)

## SAA7110

## 19.1 IIC-BUS RECEIVER-TRANSMITTER OVERVIEW TABLE

TABLE 11. IIC OCF1

OCF1-Receiver		Slave-Addresses 10011100b, 9Ch [IICSA=0] 10011110b, 9Eh [IICSA=1]							
DMSD-SQP+BCS SLAVE RECEIVER (SU 00h-19h)									
REGISTER FUNCTION	SUB ADDR	DATA BYTE							
		D7	D6	D5	D4	D3	D2	D1	D0
Increment delay	00	007 IDEL7	006 IDEL6	005 IDEL5	004 IDEL4	003 IDEL3	002 IDEL2	001 IDEL1	000 IDEL0
Horizontal sync HSY begin 50 Hz	01	015 HSYB7	014 HSYB6	013 HSYB5	012 HSYB4	011 HSYB3	010 HSYB2	009 HSYB1	008 HSYB0
Horizontal sync HSY stop 50 Hz	02	023 HSYS7	022 HSYS6	021 HSYS5	020 HSYS4	019 HSYS3	018 HSYS2	017 HSYS1	016 HSYS0
Horizontal clamp HCL begin 50 Hz	03	031 HCLB7	030 HCLB6	029 HCLB5	028 HCLB4	027 HCLB3	026 HCLB2	025 HCLB1	024 HCLB0
Horizontal clamp HCL stop 50 Hz	04	039 HCLS7	038 HCLS6	037 HCLS5	036 HCLS4	035 HCLS3	034 HCLS2	033 HCLS1	032 HCLS0
Horizontal sync after PHI1 50 Hz	05	047 HPHI7	046 HPHI6	045 HPHI5	044 HPHI4	043 HPHI3	042 HPHI2	041 HPHI1	040 HPHI0
Luminance control	06	055 BYPS	054 PREF	053 BPSS1	052 BPSS0	051 CORI1	050 CORI0	049 APER1	048 APER0
Hue control	07	063 HUEC7	062 HUEC6	061 HUEC5	060 HUEC4	059 HUEC3	058 HUEC2	057 HUEC1	056 HUEC0
Color Killer Threshold QUAM	08	071 CKTQ4	070 CKTQ3	069 CKTQ2	068 CKTQ1	067 CKTQ0	066 XXX	065 XXX	064 XXX
Color Killer Thresh. SECAM	09	079 CKTS4	078 CKTS3	077 CKTS2	076 CKTS1	075 CKTS0	074 XXX	073 XXX	072 XXX
Sensitivity PAL switch	0A	087 PLSE7	086 PLSE6	085 PLSE5	084 PLSE4	083 PLSE3	082 PLSE2	081 PLSE1	080 PLSE0
Sensitivity SECAM switch	0B	095 SESE7	094 SESE6	093 SESE5	092 SESE4	091 SESE3	090 SESE2	089 SESE1	088 SESE0
Gain Control Chrominance	0C	103 COLO	102 LFIS1	101 LFIS0	100 XXX	099 XXX	098 XXX	097 XXX	096 XXX
Standard/mode control	0D*	111 VTRC	110 XXX	109 XXX	108 XXX	107 RTSE	106 HRMV	105 SSTB	104 SECS
I/O and clock control	0E*	119 HPLL	118 XXX	117 XXX	116 OEHV	115 OEYC	114 CHR5	113 XXX	112 GPSW
Control #1	0F	127 AUFD	126 FSEL	125 SXCR	124 SCEN	123 XXX	122 YDEL2	121 YDEL1	120 YDEL0
Control #2	10	135 XXX	134 XXX	133 XXX	132 XXX	131 XXX	130 HRFS	129 VNOI1	128 VNOI0
Chroma gain reference	11	143 CHCV7	142 CHCV6	141 CHCV5	140 CHCV4	139 CHCV3	138 CHCV2	137 CHCV1	136 CHCV0
Chroma saturation	12	151 XXX	150 SATN6	149 SATN5	148 SATN4	147 SATN3	146 SATN2	145 SATN1	144 SATN0
Luminance contrast	13	159 XXX	158 CONT6	157 CONT5	156 CONT4	155 CONT3	154 CONT2	153 CONT1	152 CONT0
Horizontal sync HSY begin 60 Hz	14	167 HS6B7	166 HS6B6	165 HS6B5	164 HS6B4	163 HS6B3	162 HS6B2	161 HS6B1	160 HS6B0
Horizontal sync HSY stop 60 Hz	15	175 HS6S7	174 HS6S6	173 HS6S5	172 HS6S4	171 HS6S3	170 HS6S2	169 HS6S1	168 HS6S0
Horizontal clamp HCL begin 60 Hz	16	183 HC6B7	182 HC6B6	181 HC6B5	180 HC6B4	179 HC6B3	178 HC6B2	177 HC6B1	176 HC6B0

## One Chip Frontend 1 (OFC1)

SAA7110

TABLE 11. IIC OCF1

Horizontal clamp HCL stop 60 Hz	17	191 HC6S7	190 HC6S6	189 HC6S5	188 HC6S4	187 HC6S3	186 HC6S2	185 HC6S1	184 HC6S0
Horizontal sync after PHI1 60 Hz	18	199 HP6I7	198 HP6I6	197 HP6I5	196 HP6I4	195 HP6I3	194 HP6I2	193 HP6I1	192 HP6I0
Luminance brightness	19	207 BRIG7	206 BRIG6	205 BRIG5	204 BRIG4	203 BRIG3	202 BRIG2	201 BRIG1	200 BRIG0
<b>DUAD SLAVE RECEIVER (SU 20h-32h)</b>									
REGISTER FUNCTION	SUB ADDR	DATA BYTE							
		D7	D6	D5	D4	D3	D2	D1	D0
Analog Control #1	20	007 AIND4	006 AIND3	005 AIND2	004 FUSE1	003 FUSE0	002 AINS4	001 AINS3	000 AINS2
Analog Control #2	21	015 VBCO	014 MS34	013 MX241	012 MX240	011 MS24	010 REFS4	009 REFS3	008 REFS2
Mix Control #1	22	023 GACO1	022 GACOO	021 CSEL	020 YSEL	019 MUYC	018 CLTS	017 MX341	016 MX340
Clamp level Control 21	23	031 CLL217	030 CLL216	029 CLL215	028 CLL214	027 CLL213	026 CLL212	025 CLL211	024 CLL210
Clamp level Control 22	24	039 CLL227	038 CLL226	037 CLL225	036 CLL224	035 CLL223	034 CLL222	033 CLL221	032 CLL220
Clamp level Control 31	25	047 CLL317	046 CLL316	045 CLL315	044 CLL314	043 CLL313	042 CLL312	041 CLL311	040 CLL310
Clamp level Control 32	26	055 CLL327	054 CLL326	053 CLL325	052 CLL324	051 CLL323	050 CLL322	049 CLL321	048 CLL320
Gain Control Analog #1	27	063 HOLD	062 GASL	061 GAI25	060 GAI24	059 GAI23	058 GAI22	057 GAI21	056 GAI20
White Peak Control	28	071 WIPE7	070 WIPE6	069 WIPE5	068 WIPE4	067 WIPE3	066 WIPE2	065 WIPE1	064 WIPE0
Sync bottom Control	29	079 SBOT7	078 SBOT6	077 SBOT5	076 SBOT4	075 SBOT3	074 SBOT2	073 SBOT1	072 SBOT0
Gain Control Analog #2	2A	087 IWIP1	086 IWIP0	085 GAI35	084 GAI34	083 GAI33	082 GAI32	081 GAI31	080 GAI30
Gain Control Analog #3	2B	095 IGAI1	094 IGAI0	093 GAI45	092 GAI44	091 GAI43	090 GAI42	089 GAI41	088 GAI40
MIX Control #2	2C	103 CLS4	102 XXX	101 CLS3	100 CLS2	099 XXX	098 XXX	097 TWO3	096 TWO2
Integration value gain	2D	111 IVAL7	110 IVAL6	109 IVAL5	108 IVAL4	107 IVAL3	106 IVAL2	105 IVAL1	104 IVAL0
Blank pulse V SET	2E	119 VBPS7	118 VBPS6	117 VBPS5	116 VBPS4	115 VBPS3	114 VBPS2	113 VBPS1	112 VBPS0
Blank pulse V RESET	2F	127 VBPR7	126 VBPR6	125 VBPR5	124 VBPR4	123 VBPR3	122 VBPR2	121 VBPR1	120 VBPR0
ADCs Gain Control	30	135 XXX	134 WISL	133 GAS3	132 GAD31	131 GAD30	130 GAS2	129 GAD21	128 GAD20
MIX Control #3	31*	143 AOSL1	142 AOSL0	141 WIRS	140 WRSE	139 SQPB	138 AFCCS	137 VBLKA	136 PULIO
Integration-value white peak	32	151 WVAL7	150 WVAL6	149 WVAL5	148 WVAL4	147 WVAL3	146 WVAL2	145 WVAL1	144 WVAL0
MIX Control #4	33	159 OFTS	158 XXX	157 CHSB	156 XXX	155 CAD3	154 CAD2	153 XXX	152 XXX



## One Chip Frontend 1 (OFC1)

SAA7110

TABLE 11. IIC OCF1

Gain Up-date Level	34	167 MUD2	166 MUD1	165 GUDL5	164 GUDL4	163 GUDL3	162 GUDL2	161 GUDL1	160 GUDL0
* Subaddresses to be reset --> 0D to 7Dh, 0E and 31 to 00h after RESN=0 (CGCE=0) or POWER ON (CGCE=1) Note: All reserved XXX-bits must be set to LOW									
OCF1-Transmitter			Slave-Addresses 10011101b, 9Dh [IICSA=0] 10011111b, 9Fh [IICSA=1]						
BYTE NO. 0 (transmitted if SSTB = 0 or after RESN has been 0)									
VERSION STATUS BYTE	D7	D6	D5	D4	D3	D2	D1	D0	
	ID7	ID6	ID5	ID4	ID3	ID2	ID1	ID0	
ID(7:0)	Indicates the version number of the IC e.g. : SAA7110 V1 = 01h								
BYTE NO. 1 (transmitted if SSTB = 1)									
STATUS BYTE FUNCTION	D7	D6	D5	D4	D3	D2	D1	D0	
	STTC	HLCK	FIDT	GLIM	XXX	WIPA	ALTD	CODE	
STTC	Status Bit for horizontal time constant. Status LOW: TV-time constant, HIGH: VCR-time-constant								
HLCK	Status Bit for locked horizontal frequency. Status LOW: locked, HIGH: unlocked								
FIDT	Identification Bit for detected field frequency. Status LOW: 50 Hz, HIGH: 60 Hz								
GLIM	Gain value for active luminance channel is limited (max or min), active HIGH								
XXX	reserved								
WIPA	White peak loop is activated, active HIGH								
ALTD	Status HIGH: Line-alternating color burst has been detected (PAL or SECAM)								
CODE	Status HIGH: Any color signal has been detected								

## One Chip Frontend 1 (OFC1)

SAA7110

TABLE 12. IIC DETAIL SU00h-04h(000-039)

<b>IIC-RECEIVER (SLAVE-ADDRESS 9Ch / 9Eh)</b>									
<b>DMSD-SQP SLAVE RECEIVER (SU 00h-19h)</b>									
<b>Subaddress 00 Increment delay IDEL</b>									<b>007-000</b>
<b>DECIMAL MULTIPLIER</b>	<b>DELAY TIME (STEP SIZE = 4/LLC)</b>	<b>CONTROL BITS*</b>							
		<b>IDEL7</b>	<b>IDEL6</b>	<b>IDEL5</b>	<b>IDEL4</b>	<b>IDEL3</b>	<b>IDEL2</b>	<b>IDEL1</b>	<b>IDEL0</b>
-1...	-4	1	1	1	1	1	1	1	1
... -195	-780 (max. value for 60 Hz systems)	0	0	1	1	1	1	0	1
... -236	-944 (max. value for 50 Hz systems)	0	0	0	1	0	1	0	0
... -256	-1024 (outside central counter)**	0	0	0	0	0	0	0	0
<b>Where:</b> * A sign bit, designated A08 and internally set to HIGH, indicates values are always negative. ** The horizontal PLL does not operate in this condition. The system clock frequency is set to a value fixed by the last update and is within +/-7.1% of the nominal frequency.									
<b>Subaddress 01 Horizontal sync begin 50 Hz HSYB</b>									<b>015-008</b>
<b>DECIMAL MULTIPLIER</b>	<b>DELAY TIME (STEP SIZE = 2/LLC)</b>	<b>CONTROL BITS</b>							
		<b>HSYB7</b>	<b>HSYB6</b>	<b>HSYB5</b>	<b>HSYB4</b>	<b>HSYB3</b>	<b>HSYB2</b>	<b>HSYB1</b>	<b>HSYB0</b>
+191...	-382	1	0	1	1	1	1	1	1
... -64	+128	1	1	0	0	0	0	0	0
<b>Subaddress 02 Horizontal sync stop 50 Hz HSYS</b>									<b>023-016</b>
<b>DECIMAL MULTIPLIER</b>	<b>DELAY TIME (STEP SIZE = 2/LLC)</b>	<b>CONTROL BITS</b>							
		<b>HSYS7</b>	<b>HSYS6</b>	<b>HSYS5</b>	<b>HSYS4</b>	<b>HSYS3</b>	<b>HSYS2</b>	<b>HSYS1</b>	<b>HSYS0</b>
+191...	-382	1	0	1	1	1	1	1	1
... -64	+128	1	1	0	0	0	0	0	0
<b>Subaddress 03 Horizontal clamp begin 50 Hz HCLB</b>									<b>031-024</b>
<b>DECIMAL MULTIPLIER</b>	<b>DELAY TIME (STEP SIZE = 2/LLC)</b>	<b>CONTROL BITS</b>							
		<b>HCLB7</b>	<b>HCLB6</b>	<b>HCLB5</b>	<b>HCLB4</b>	<b>HCLB3</b>	<b>HCLB2</b>	<b>HCLB1</b>	<b>HCLB0</b>
+127...	-254	0	1	1	1	1	1	1	1
... -128	+256	1	0	0	0	0	0	0	0
<b>Subaddress 04 Horizontal clamp stop 50 Hz HCLS</b>									<b>039-032</b>
<b>DECIMAL MULTIPLIER</b>	<b>DELAY TIME (STEP SIZE = 2/LLC)</b>	<b>CONTROL BITS</b>							
		<b>HCLS7</b>	<b>HCLS6</b>	<b>HCLS5</b>	<b>HCLS4</b>	<b>HCLS3</b>	<b>HCLS2</b>	<b>HCLS1</b>	<b>HCLS0</b>
+127...	-254	0	1	1	1	1	1	1	1
... -128	+256	1	0	0	0	0	0	0	0

## One Chip Frontend 1 (OFC1)

SAA7110

TABLE 13. II DETAIL SU05h-06h(040-055)

Subaddress 05 Horizontal sync start after PHI1 50 Hz HPHI		047-040							
DECIMAL MULTIPLIER	DELAY TIME (STEP SIZE = 8/LLC)	CONTROL BITS							
		HPHI7	HPHI6	HPHI5	HPHI4	HPHI3	HPHI2	HPHI1	HPHI0
+127...	Forbidden; outside available central counter range	0	1	1	1	1	1	1	1
... +118	Forbidden; outside available central counter range	0	1	1	1	0	1	1	0
+117...	-32 $\mu$ s (max. negative value)	0	1	1	1	0	1	0	1
... -118	+31.7 $\mu$ s (max. positive value)	1	0	0	0	1	0	1	0
-119...	Forbidden; outside available central counter range	1	0	0	0	1	0	0	1
... -128	Forbidden; outside available central counter range	1	0	0	0	0	0	0	0
Subaddress 06 Luminance control		055-048							
Aperture factor APER		049-048							
APERTURE FACTOR		CONTROL BITS							
		APER1				APER0			
0	0	0				0			
1	0.25	0				1			
2	0.5	1				0			
3	1	1				1			
Corner correction CORI		050							
CORING +/- LSBS IN 8 BIT		CONTROL BITS CORI							
0	0 (OFF)	0				0			
1	1	0				1			
2	2	1				0			
3	3	1				1			
Aperture bandpass (center frequency) BPSS		053-052							
BANDPASS CENTER FREQ.		CONTROL BITS							
		BPSS1				BPSS0			
50 Hz	60 Hz								
4.6 MHz	3.8 MHz	0				0			
4.3 MHz	3.4 MHz	0				1			
3.0 MHz	2.5 MHz	1				0			
3.2 MHz	2.7 MHz	1				1			

## One Chip Frontend 1 (OFC1)

SAA7110

TABLE 13. II DETAIL SU05h-06h(040-055)

Prefilter active PREF		054
<b>PREFILTER</b>	<b>CONTROL BIT PREF</b>	
Bypassed	0	
Active	1	
Chrominance trap bypass BYPS		055
<b>CHROMA TRAP</b>	<b>MODE</b>	<b>CONTROL BIT BYPS</b>
Active	CVBS	
Bypassed	S-Video	

TABLE 14. II DETAIL SU07h-08h(056-095)

Subaddress 07 Hue phase control HUEC									063-056
<b>HUE PHASE (DEG)</b>	<b>CONTROL BITS</b>								
	HUEC7	HUEC6	HUEC5	HUEC4	HUEC3	HUEC2	HUEC1	HUEC0	
+178.6...	0	1	1	1	1	1	1	1	
... 0...	0	0	0	0	0	0	0	0	
... -180	1	0	0	0	0	0	0	0	
Subaddress 08 Control number 1									071-064
Color killer threshold QAM (PAL/NTSC) CKTQ									071-067
<b>THRESHOLD</b> (reference is nominal burst amplitude = 0 dB)	<b>CONTROL BITS</b>								
	CKTQ4	CKTQ3	CKTQ2	CKTQ1	CKTQ0				
-30 dB...	1	1	1	1	1				
... -24 dB...	1	0	0	0	0				
... -18 dB	0	0	0	0	0				
Subaddress 09 Control number 2									079-072
Color killer threshold SECAM CKTS									079-075
<b>THRESHOLD</b> (reference is nominal burst amplitude = 0 dB)	<b>CONTROL BITS</b>								
	CKTS4	CKTS3	CKTS2	CKTS1	CKTS0				
-30 dB...	1	1	1	1	1				
... -24 dB...	1	0	0	0	0				
... -18 dB	0	0	0	0	0				
Subaddress 0A PAL switch sensitivity PLSE									087-080
<b>SENSITIVITY</b>	<b>CONTROL BITS</b>								
	PLSE7	PLSE6	PLSE5	PLSE4	PLSE3	PLSE2	PLSE1	PLSE0	
LOW	1	1	1	1	1	1	1	1	
MEDIUM	1	0	0	0	0	0	0	0	
HIGH	0	0	0	0	0	0	0	0	

## One Chip Frontend 1 (OFC1)

SAA7110

TABLE 14. II DETAIL SU07h-0Bh(056-095)

Subaddress 0B SECAM switch sensitivity SESE								095-088
SENSITIVITY	CONTROL BITS							
	SESE7	SESE6	SESE5	SESE4	SESE3	SESE2	SESE1	SESE0
LOW	1	1	1	1	1	1	1	1
MEDIUM	1	0	0	0	0	0	0	0
HIGH	0	0	0	0	0	0	0	0

Sensitivity HIGH means immediate sequence correction

TABLE 15. IIC DETAIL SU0Ch-0Eh(096-119)

Subaddress 0C Gain control chrominance			103-096
AGC (Automatic Gain Control) - loop filter LFIS			102-101
AGC - LOOP FILTER TIME CONSTANT	CONTROL BITS		
	LFIS1	LFIS0	
Slow	0	0	
Medium	0	1	
Fast	1	0	
Actual chroma gain 'frozen'	1	1	
Color on COLO			103
COLOUR ON	CONTROL BIT COLO		
Automatic color killer	0		
Color forced on	1		
Subaddress 0D Standard/mode control			111-104
SECAM mode bit SECS			104
FUNCTION	CONTROL BIT SECS		
other standards	0		
SECAM	1		
Status Byte select SSTB			105
FUNCTION	CONTROL BIT SSTB		
Statusbyte is Byte 0 (see Transmitter)	0		
Statusbyte is Byte 1 (see Transmitter)	1		
HREF-POSITION select HRMV			106
FUNCTION	CONTROL BIT HRMV		
HREF position like SAA7191 (8 LLC2 later)	0		
HREF normal position	1		

## One Chip Frontend 1 (OFC1)

SAA7110

TABLE 15. IIC DETAIL SU0Ch-0Eh(096-119)

Real-time-outputs-mode select RTSE		107
<b>FUNCTION</b>	<b>CONTROL BIT RTSE</b>	
PLIN switched to output pin 39 ODD switched to output pin 40	0	
HL switched to output pin 39 VL switched to output pin 40	1	
TV/VCR-mode select VTRC		111
<b>FUNCTION</b>	<b>CONTROL BIT VTRC</b>	
TV mode	0	
VTR mode	1	
<b>Subaddress 0E I/O and clock control</b>		<b>119-112</b>
General purpose switch GPSW		112
<b>FUNCTION</b>	<b>CONTROL BIT GPSW</b>	
switches directly pin 64 GPSW (application dependent) [VBLKA = 0]	0	
	1	

TABLE 16. IIC DETAIL SU0Eh-0Fh(114-127)

Select chrominance input CHRS		114
<b>FUNCTION</b>	<b>CONTROL BIT CHRS</b>	
controlled by BYPS (subaddress 06)	0	
chroma input is CHR(7:0)	1	
Output enable YUV-data OEYC		115
<b>FUNCTION</b>	<b>CONTROL BIT OEYC</b>	
YUV-bus high impedance/input	0	
Output YUV-bus active	1	
Output enable horizontal/vertical sync OEHV		116
<b>FUNCTION</b>	<b>CONTROL BIT OEHV</b>	
HS, HREF and VS high impedance/inputs	0	
Output HS, HREF and VS active	1	
Horizontal PLL clock HPLL		119
<b>FUNCTION</b>	<b>CONTROL BIT HPLL</b>	
PLL closed	0	
PLL open, horizontal frequency fixed	1	

## One Chip Frontend 1 (OFC1)

SAA7110

TABLE 16. IIC DETAIL SU0Eh-0Fh(114-127)

<b>Subaddress 0F Control number 1</b>		<b>127-120</b>	
Luminance delay compensation YDEL		122-120	
LUMINANCE DELAY COMPENSATION (steps in 2/LLC)	CONTROL BITS		
	YDEL2	YDEL1	YDEL0
0	0	0	0
3	0	1	1
-4	1	0	0
Enable or disable of sync and clamp pulses (HSY, HCL) SCEN		124	
FUNCTION	CONTROL BIT SCEN		
Disable sync and clamp (set to HIGH)	0		
Enable sync and clamp	1		
SECAM cross color reduction SXCR		125	
FUNCTION	CONTROL BIT SXCR		
Reduction OFF	0		
Reduction ON	1		
Field selection FSEL		126	
FUNCTION	CONTROL BIT FSEL		
50 Hz, 625 lines	0		
60 Hz, 525 lines	1		
Automatic field detection AUFD		127	
FUNCTION	CONTROL BIT AUFD		
Field state direct controlled via FSEL	0		
Automatic field detection	1		

TABLE 17. IIC DETAIL SU10h-13h(128-158)

<b>Subaddress 10 Control number 2</b>		<b>135-128</b>	
Vertical noise reduction VNOI		129-128	
FUNCTION	CONTROL BITS		
	VNOI1	VNOI0	
Normal mode	0	0	
Searching mode	0	1	
Free running mode	1	0	
Vertical noise reduction bypassed	1	1	
HREF select HRFS		130	
FUNCTION	CONTROL BIT HRFS		
HREF matched to YUV output	0		
HREF matched to CVBS input	1		

One Chip Frontend 1 (OFC1)

SAA7110

TABLE 17. IIC DETAIL SU10h-13h(128-158)

Subaddress 11 Chrominance gain reference value CHCV									143-136
REFERENCE VALUE	CONTROL BITS								
	CHCV7	CHCV6	CHCV5	CHCV4	CHCV3	CHCV2	CHCV1	CHCV0	
Maximum	1	1	1	1	1	1	1	1	
CCIR-level for PAL	0	1	0	1	1	0	0	1	
CCIR-level for NTSC	0	0	1	0	1	1	0	0	
Minimum	0	0	0	0	0	0	0	0	

Subaddress 12 Chrominance Saturation Control									150-144
GAIN	CONTROL BITS								
	SATN7	SATN6	SATN5	SATN4	SATN3	SATN2	SATN1	SATN0	
1.999 (MAXIMUM)	0	1	1	1	1	1	1	1	
1 (CCIR-level)	0	1	0	0	0	0	0	0	
0 (COLOUR OFF)	0	0	0	0	0	0	0	0	
-1 (inverse chroma)	1	1	0	0	0	0	0	0	
-2 (inverse chroma)	1	0	0	0	0	0	0	0	

Subaddress 13 Luminance Contrast Control									158-152
GAIN	CONTROL BITS								
	CONT7	CONT6	CONT5	CONT4	CONT3	CONT2	CONT1	CONT0	
1.999 (MAXIMUM)	0	1	1	1	1	1	1	1	
70(CCIR-level)	0	1	0	0	0	1	1	0	
1	0	1	0	0	0	0	0	0	
0 (LUMINANCE OFF)	0	0	0	0	0	0	0	0	
-1 (inverse luminance)	1	1	0	0	0	0	0	0	
-2 (inverse luminance)	1	0	0	0	0	0	0	0	

TABLE 18. IIC DETAIL SU14h-18h(160-199)

Subaddress 14 Horizontal sync begin 60 Hz HS6B										167-160
DECIMAL MULTIPLIER	DELAY TIME (STEP SIZE = 2/LLC)	CONTROL BITS								
		HS6B7	HS6B6	HS6B5	HS6B4	HS6B3	HS6B2	HS6B1	HS6B0	
+191...	-382	1	0	1	1	1	1	1	1	
... -64	+128	1	1	0	0	0	0	0	0	

Subaddress 15 Horizontal sync stop 60 Hz HS6S										175-168
DECIMAL MULTIPLIER	DELAY TIME (STEP SIZE = 2/LLC)	CONTROL BITS								
		HS6S7	HS6S6	HS6S5	HS6S4	HS6S3	HS6S2	HS6S1	HS6S0	
+191...	-382	1	0	1	1	1	1	1	1	
... -64	+128	1	1	0	0	0	0	0	0	



## One Chip Frontend 1 (OFC1)

SAA7110

TABLE 18. IIC DETAIL SU14h-18h(160-199)

Subaddress 16 Horizontal clamp begin 60 Hz HC6B										183-176
DECIMAL MULTIPLIER	DELAY TIME (STEP SIZE = 2/LLC)	CONTROL BITS								
		HC6B7	HC6B6	HC6B5	HC6B4	HC6B3	HC6B2	HC6B1	HC6B0	
+127...	-254	0	1	1	1	1	1	1	1	
... -128	+256	1	0	0	0	0	0	0	0	
Subaddress 17 Horizontal clamp stop 60 Hz HC6S										191-184
DECIMAL MULTIPLIER	DELAY TIME (STEP SIZE = 2/LLC)	CONTROL BITS								
		HCL67	HC6S6	HC6S5	HC6S4	HC6S3	HC6S2	HC6S1	HC6S0	
+127...	-254	0	1	1	1	1	1	1	1	
... -128	+256	1	0	0	0	0	0	0	0	
Subaddress 18 Horizontal sync start after PHI1 60 Hz HP6I										199-192
DECIMAL MULTIPLIER	DELAY TIME (STEP SIZE = 8/LLC)	CONTROL BITS								
		HP6I7	HP6I6	HP6I5	HP6I4	HP6I3	HP6I2	HP6I1	HP6I0	
+127...	Forbidden; outside available central counter range	0	1	1	1	1	1	1	1	
... +98	Forbidden; outside available central counter range	0	1	1	0	0	0	1	0	
+97...	-32 $\mu$ s (max. negative value)	0	1	1	0	0	0	0	1	
... -97	+31.7 $\mu$ s (max. positive value)	1	0	0	1	1	1	1	1	
-98...	Forbidden; outside available central counter range	1	0	0	1	1	1	1	0	
... -128	Forbidden; outside available central counter range	1	0	0	0	0	0	0	0	

TABLE 19. IIC DETAIL SU19h(200-207)

Subaddress 19 Luminance brightness control									207-200
OFFSET	CONTROL BITS								
	BRIG7	BRIG6	BRIG5	BRIG4	BRIG3	BRIG2	BRIG1	BRIG0	
255 (bright)	1	1	1	1	1	1	1	1	
139 (CCIR-level)	1	0	0	0	1	0	1	1	
128	1	0	0	0	0	0	0	0	
0 (dark)	0	0	0	0	0	0	0	0	

## One Chip Frontend 1 (OFC1)

SAA7110

TABLE 20. IIC DETAIL SU20h(000-006)

DUAD SLAVE RECEIVER (SU 20h-32h)		
<b>Subaddress 20 Analog control #1</b>		<b>007-000</b>
Analog input select 2 AINS2		000
<b>FUNCTION</b>	<b>CONTROL BIT AINS2</b>	
Analog input AI22 selected	0	
Analog input AI21 selected	1	
Analog input select 3 AINS3		001
<b>FUNCTION</b>	<b>CONTROL BIT AINS3</b>	
Analog input AI32 selected	0	
Analog input AI31 selected	1	
Analog input select 4 AINS4		002
<b>FUNCTION</b>	<b>CONTROL BIT AINS4</b>	
Analog input AI42 selected	0	
Analog input AI41 selected	1	
Analog function select FUSE		004-003
<b>FUNCTION</b>	<b>CONTROL BITS FUSE(1:0)</b>	
	<b>FUSE1</b>	<b>FUSE0</b>
AMPLIFIER + ANTI ALIAS FILTER bypassed	0	0
	0	1
AMPLIFIER active	1	0
AMPLIFIER + ANTI ALIAS FILTER active	1	1
Analog input disable 2 AIND2		005
<b>FUNCTION</b>	<b>CONTROL BIT AIND2</b>	
Analog inputs 2 enabled	0	
Analog inputs 2 disabled	1	
Analog input disable 3 AIND3		006
<b>FUNCTION</b>	<b>CONTROL BIT AIND3</b>	
Analog inputs 3 enabled	0	
Analog inputs 3 disabled	1	

TABLE 21. IIC DETAIL SU20h-21h(007-015)

Analog input disable 4 AIND4		007
<b>FUNCTION</b>	<b>CONTROL BIT AIND4</b>	
Analog inputs 4 enabled	0	
Analog inputs 4 disabled	1	

## One Chip Frontend 1 (OFC1)

SAA7110

TABLE 21. IIC DETAIL SU20h-21h(007-015)

Subaddress 21 Analog control #2		015-008
Reference select channel 2 REFS2		008
FUNCTION	CONTROL BIT REFS2	
Automatic clamping active	0	
Reference level selected	1	
Reference select channel 3 REFS3		009
FUNCTION	CONTROL BIT REFS3	
Automatic clamping active	0	
Reference level selected	1	
Reference select channel 4 REFS4		010
FUNCTION	CONTROL BIT REFS4	
Automatic clamping active	0	
Reference level selected	1	
MUXC select channel 24 MS24		011
FUNCTION	CONTROL BIT MS24	
Analog MUX2 controlled by MX24	0	
Analog MUX2 controlled by MUXC	1	
Analog MUX2 control MX24		013-012
FUNCTION	CONTROL BITS MX24(1:0)	
	MX241	MX240
ADDER mode	0	0
ch2 on, ch4 off	0	1
ch2 off, ch4 on	1	0
both off	1	1
MUXC select channel 34 MS34		014
FUNCTION	CONTROL BIT MS34	
Analog MUX3 controlled by MX34	0	
Analog MUX3 controlled by MUXC	1	
Vertical blanking control off VBCO		015
FUNCTION	CONTROL BIT VBCO	
vertical blanking on	0	
vertical blanking off	1	

## One Chip Frontend 1 (OFC1)

SAA7110

TABLE 22. IIC DETAIL SU22h-23h(016-031)

<b>Subaddress 22 Mix control #1</b>		<b>023-016</b>
Analog MUX3 control MX34		017-016
<b>FUNCTION</b>	<b>CONTROL BITS MX34(1:0)</b>	
	<b>MX341</b>	<b>MX340</b>
ADDER mode	0	0
ch3 on, ch4 off	0	1
ch3 off, ch4 on	1	0
both off	1	1
Clamp function test CLTS		018
<b>FUNCTION</b>	<b>CONTROL BIT CLTS</b>	
normal clamp mode	0	
CLAA <sub>n</sub> , CLAU <sub>n</sub> adjusted via CLL32 value for testing (do not use)	1	
Fast digital multiplexing channel 2/3 active MUYC		019
<b>FUNCTION</b>	<b>CONTROL BIT MUYC</b>	
normal mode on CHR channel	0	
multiplex mode on CHR channel for test purpose only (do not use)	1	
Luminance select YSEL		020
<b>FUNCTION</b>	<b>CONTROL BIT YSEL</b>	
AD converter 2 -> CVBS	0	
AD converter 3 -> CVBS	1	
Chrominance select CSEL		021
<b>FUNCTION</b>	<b>CONTROL BIT CSEL</b>	
AD converter 3 -> CHR (MUXC not inverse (MUYC=1))	0	
AD converter 2 -> CHR (MUXC inverse (MUYC=1))	1	
Automatic gain control GACO		023-022
<b>FUNCTION</b>	<b>CONTROL BITS GACO(1:0)</b>	
	<b>GACO1</b>	<b>GACO0</b>
automatic gain control off	0	0
automatic gain control channel 2	0	1
automatic gain control channel 3	1	0
automatic gain control channel 4	1	1

One Chip Frontend 1 (OFC1)

SAA7110

TABLE 22. IIC DETAIL SU22h-23h(016-031)

Subaddress 23 Clamp level control 21 CLL21								031-024
DECIMAL CLAMP LEVEL	CONTROL BITS							
	CLL217	CLL216	CLL215	CLL214	CLL213	CLL212	CLL211	CLL210
1...	0	0	0	0	0	0	0	1
... 64...	0	1	0	0	0	0	0	0
... 128...	1	0	0	0	0	0	0	0
... 254	1	1	1	1	1	1	1	0

TABLE 23. IIC DETAIL SU24h-SU27h(032-063)

Subaddress 24 Clamp level control 22 CLL22								039-032
DECIMAL CLAMP LEVEL	CONTROL BITS							
	CLL227	CLL226	CLL225	CLL224	CLL223	CLL222	CLL221	CLL220
1...	0	0	0	0	0	0	0	1
... 64...	0	1	0	0	0	0	0	0
... 128...	1	0	0	0	0	0	0	0
... 254	1	1	1	1	1	1	1	0

Subaddress 25 Clamp level control 31 CLL31								047-040
DECIMAL CLAMP LEVEL	CONTROL BITS							
	CLL317	CLL316	CLL315	CLL314	CLL313	CLL312	CLL311	CLL310
1...	0	0	0	0	0	0	0	1
... 64...	0	1	0	0	0	0	0	0
... 128...	1	0	0	0	0	0	0	0
... 254	1	1	1	1	1	1	1	0

Subaddress 26 Clamp level control 32 CLL32								055-048
DECIMAL CLAMP LEVEL	CONTROL BITS							
	CLL327	CLL326	CLL325	CLL324	CLL323	CLL322	CLL321	CLL320
1...	0	0	0	0	0	0	0	1
... 64...	0	1	0	0	0	0	0	0
... 128...	1	0	0	0	0	0	0	0
... 254	1	1	1	1	1	1	1	0

One Chip Frontend 1 (OFC1)

SAA7110

TABLE 23. IIC DETAIL SU24h-SU27h(032-063)

<b>Subaddress 27 Gain control analog #1</b>									<b>063-056</b>
Static gain control channel 2 GAI2									061-056
DECIMAL MULTIPLIER	GAIN (STEP SIZE = 0.19 dB)	CONTROL BITS							
			GAI25	GAI24	GAI23	GAI22	GAI21	GAI20	
0...	-2.82 dB		0	0	0	0	0	0	
... 15...	0 dB		0	0	1	1	1	1	
... 31...	+3 dB		0	1	1	1	1	1	
... 47...	+6 dB		1	0	1	1	1	1	
... 63	+9 dB		1	1	1	1	1	1	
Gain mode select GASL									062
FUNCTION		CONTROL BIT GASL							
difference value integration		0							
fix value integration		1							
Automatic gain control integration HOLD									063
FUNCTION		CONTROL BIT HOLD							
AGC active		0							
AGC integration hold (freeze)		1							

TABLE 24. IIC DETAIL SU28h-2Bh(064-093)

<b>Subaddress 28 White peak control WIPE</b>									<b>071-064</b>
DECIMAL WHITE PEAK LEVEL	CONTROL BITS								
	WIPE7	WIPE6	WIPE5	WIPE4	WIPE3	WIPE2	WIPE1	WIPE0	
128...	1	0	0	0	0	0	0	0	
... 254	1	1	1	1	1	1	1	0	
255 (White peak control off)	1	1	1	1	1	1	1	1	
<b>Subaddress 29 Sync bottom control SBOT</b>									<b>079-072</b>
DECIMAL SYNC BOTTOM LEVEL	CONTROL BITS								
	SBOT7	SBOT6	SBOT5	SBOT4	SBOT3	SBOT2	SBOT1	SBOT0	
1...	0	0	0	0	0	0	0	1	
... 254	1	1	1	1	1	1	1	0	

One Chip Frontend 1 (OFC1)

SAA7110

TABLE 24. IIC DETAIL SU28h-2Bh(064-093)

<b>Subaddress 2A Gain control analog #2</b>								<b>087-080</b>
Static gain control channel 3 GAI3								085-080
DECIMAL MULTIPLIER	GAIN (STEP SIZE = 0.19 dB)	CONTROL BITS						
		GAI35	GAI34	GAI33	GAI32	GAI31	GAI30	
0...	-2.82 dB	0	0	0	0	0	0	
... 15...	0 db	0	0	1	1	1	1	
... 31...	+ 3 dB	0	1	1	1	1	1	
... 47...	+6 dB	1	0	1	1	1	1	
... 63	+9 dB	1	1	1	1	1	1	
Integration factor white peak IWIP								087-086
FUNCTION	CONTROL BITS IWIP(1:0)							
	IWIP1			IWIP0				
fast	0			0				
	0			1				
	1			0				
slow	1			1				
<b>Subaddress 2B Gain control analog #3</b>								<b>095-088</b>
Static gain control channel 4 GAI4								093-088
DECIMAL MULTIPLIER	GAIN (STEP SIZE = 0.19 dB)	CONTROL BITS						
		GAI45	GAI44	GAI43	GAI42	GAI41	GAI40	
0...	-2.82 dB	0	0	0	0	0	0	
... 15...	0 db	0	0	1	1	1	1	
... 31...	+ 3 dB	0	1	1	1	1	1	
... 47...	+6 dB	1	0	1	1	1	1	
... 63	+9 dB	1	1	1	1	1	1	

TABLE 25. IIC DETAIL SU2Bh-2Eh(094-119)

<b>Integration factor normal gain IGA1</b>								<b>095-094</b>
FUNCTION	CONTROL BITS IGA1(1:0)							
	IGA11			IGA10				
slow	0			0				
	0			1				
	1			0				
fast	1			1				

## One Chip Frontend 1 (OFC1)

SAA7110

TABLE 25. IIC DETAIL SU2Bh-2Eh(094-119)

<b>Subaddress 2C Mix control #2</b>									<b>103-096</b>	
Two's complement channel 2 TWO2									096	
<b>FUNCTION</b>			<b>CONTROL BIT TWO2</b>							
unipolar			0							
two's complement (normal mode)			1							
Two's complement channel 3 TWO3									097	
<b>FUNCTION</b>			<b>CONTROL BIT TWO3</b>							
unipolar			0							
two's complement (normal mode)			1							
Clamp level select channel 2 CLS2									100	
<b>FUNCTION</b>			<b>CONTROL BIT CLS2</b>							
CLL21 active			0							
CLL22 active			1							
Clamp level select channel 3 CLS3									101	
<b>FUNCTION</b>			<b>CONTROL BIT CLS3</b>							
CLL31 active			0							
CLL32 active			1							
Clamp level select channel 4 CLS4									103	
<b>FUNCTION</b>			<b>CONTROL BIT CLS4</b>							
CLL2n active			0							
CLL3n active			1							
<b>Subaddress 2D Integration value gain IVAL</b>									<b>111-104</b>	
<b>DECIMAL INTEGRATION VALUE GAIN</b>			<b>CONTROL BITS</b>							
			<b>IVAL7</b>	<b>IVAL6</b>	<b>IVAL5</b>	<b>IVAL4</b>	<b>IVAL3</b>	<b>IVAL2</b>	<b>IVAL1</b>	<b>IVAL0</b>
1...			0	0	0	0	0	0	0	1
... 255			1	1	1	1	1	1	1	1
<b>Subaddress 2E Blank pulse VBLK-set VBPS</b>									<b>119-112</b>	
<b>DECIMAL MULTIPLIER</b>		<b>SET LINE NUMBER step size = 2</b>		<b>CONTROL BITS</b>						
				<b>VBPS7</b>	<b>VBPS6</b>	<b>VBPS5</b>	<b>VBPS4</b>	<b>VBPS3</b>	<b>VBPS2</b>	<b>VBPS1</b>
0...		0 after ^VS		0	0	0	0	0	0	0
...131... (max. for 60Hz)		262 after ^VS		1	0	0	0	0	0	1
...156 (max. for 50Hz)		312 after ^VS		1	0	0	1	1	1	0



One Chip Frontend 1 (OFC1)

SAA7110

TABLE 26. IIC DETAIL SU2Fh-31h(120-143)

<b>Subaddress 2F Blank pulse VBLK-reset VBPR</b>									<b>127-120</b>
DECIMAL MULTI-PLIER	RESET LINE NUM-BER step size = 2	CONTROL BITS							
		VBPR7	VBPR6	VBPR5	VBPR4	VBPR3	VBPR2	VBPR1	VBPR0
0...	0 after ^VS	0	0	0	0	0	0	0	0
...131... (max. for 60Hz)	262 after ^VS	1	0	0	0	0	0	1	1
...156 (max. for 50Hz)	312 after ^VS	1	0	0	1	1	1	0	0
<b>Subaddress 30 ADCs gain control</b>									<b>135-128</b>
Fix gain A/D converter channel 2 GAD2									129-128
FUNCTION	CONTROL BITS GAD2(1:0)								
	GAD21				GAD20				
0 dB	0				0				
0.05 dB	0				1				
0.10 dB	1				0				
0.15 dB	1				1				
Gain A/D select channel 2 GAS2									130
FUNCTION	CONTROL BIT GAS2								
fix gain via IIC GAD2	0								
automatic gain via loop	1								
Fix gain A/D converter channel 3 GAD3									132-131
FUNCTION	CONTROL BITS GAD3(1:0)								
	GAD31				GAD30				
0 dB	0				0				
0.05 dB	0				1				
0.10 dB	1				0				
0.15 dB	1				1				
Gain A/D select channel 3 GAS3									133
FUNCTION	CONTROL BIT GAS3								
fix gain via IIC GAD3	0								
automatic gain via loop	1								
White peak mode select WISL									134
FUNCTION	CONTROL BIT WISL								
difference value integration	0								
fix value integration	1								
<b>Subaddress 31 Mix control #3</b>									<b>143-136</b>
Pulses I/O control PULIO									136
FUNCTION	CONTROL BIT PULIO								
HCL, HSY -> input pins	0								
HCL, HSY -> output pins	1								

## One Chip Frontend 1 (OFC1)

SAA7110

TABLE 27. IIC DETAIL SU31h-33h(137-154)

Pin function switch VBLKA		137						
<b>FUNCTION</b>	<b>CONTROL BIT VBLKA</b>							
GPSW active (normal)	0							
VBLK test output active	1							
Analog filter control clock select AFCCS		138						
<b>FUNCTION</b>	<b>CONTROL BIT AFCCS</b>							
not divided (control clock = LLC/2), cut frequency approximate 10MHz	0							
divided (control clock = LLC/4), cut frequency approximate. 5MHz	1							
DMSD-SQP bypassed SQPB		139						
<b>FUNCTION</b>	<b>CONTROL BIT SQPB</b>							
DMSD-data to YUV output	0							
A/D-data to YUV output for test purpose only (do not use)	1							
White peak slow up integration enable WRSE		140						
<b>FUNCTION</b>	<b>CONTROL BIT WRSE</b>							
hold in white peak mode	0							
slow up integration with one value in H or V (dependent on WIRS)	1							
White peak slow up integration select WIRS		141						
<b>FUNCTION</b>	<b>CONTROL BIT WIRS</b>							
slow up integration with one value per line	0							
slow up integration with one value per field	1							
Analog test select AOSL		143-142						
<b>FUNCTION</b>	<b>CONTROL BITS AOSL(1:0)</b>							
	<b>AOSL1</b>	<b>AOSL0</b>						
AOUT connected to ground	0	0						
AOUT connected to input AD2	0	1						
AOUT connected to input AD3	1	0						
AOUT connected to channel 4	1	1						
Subaddress 32 Integration value white peak IVAL		151-144						
<b>DECIMAL INTEGRATION VALUE WHITE PEAK</b>	<b>CONTROL BITS</b>							
	<b>WVAL7</b>	<b>WVAL6</b>	<b>WVAL5</b>	<b>WVAL4</b>	<b>WVAL3</b>	<b>WVAL2</b>	<b>WVAL1</b>	<b>WVAL0</b>
1...	0	0	0	0	0	0	0	1
... 127 (max.)	0	1	1	1	1	1	1	1

One Chip Frontend 1 (OFC1)

SAA7110

TABLE 27. IIC DETAIL SU31h-33h(137-154)

<b>Subaddress 33 Mix control #4</b>		<b>159-152</b>
Clock select AD2 CAD2		154
<b>FUNCTION</b>	<b>CONTROL BIT CAD2</b>	
LLC for test purpose only (do not use)	0	
LLC/2	1	

TABLE 28. IIC DETAIL SU33h-34h(155-167)

Clock select AD3 CAD3		155	
<b>FUNCTION</b>	<b>CONTROL BIT CAD3</b>		
LLC for test purpose only (do not use)	0		
LLC/2	1		
Change sign bit UV data CHSB		157	
<b>FUNCTION</b>	<b>CONTROL BIT CHSB</b>		
UV output unipolar	0		
UV output two's complement	1		
Output format select OFTS		159	
<b>FUNCTION</b>	<b>CONTROL BIT OFTS</b>		
4:1:1 format	0		
4:2:2 format	1		
<b>Subaddress 34 Gain update level</b>		<b>167-160</b>	
Gain update level GUDL		165-160	
<b>DECIMAL</b>	<b>HYSTERESIS for 8bit gain</b>	<b>update   new gain - old gain   =</b>	<b>CONTROL BITS GUDL(5:0)</b>
			<b>GUDL5 GUDL4 GUDL3 GUDL2 GUDL1 GUDL0</b>
0...	0 LSB	>0	0 0 0 0 0 0
... 7.....	+/- 7 LSB	>7	0 0 0 1 1 1
>31	OFF	always	1 X X X X X
MUXC phase delay MUD2(1)		167-166	
<b>FUNCTION</b>	<b>CONTROL BITS</b>		
	<b>MUD2</b>	<b>MUD1</b>	
no phase delay	0	0	
1 LLC cycle phase delay for CLAA path	0	1	
2 LLC cycle phase delay for CLAA path	1	0	
3 LLC cycle phase delay for CLAA path	1	1	

# One Chip Frontend 1 (OFC1)

# SAA7110

## 19.2 SOURCE SELECTION MANAGEMENT

FIGURE 20. SOURCE SELECTION OVERVIEW

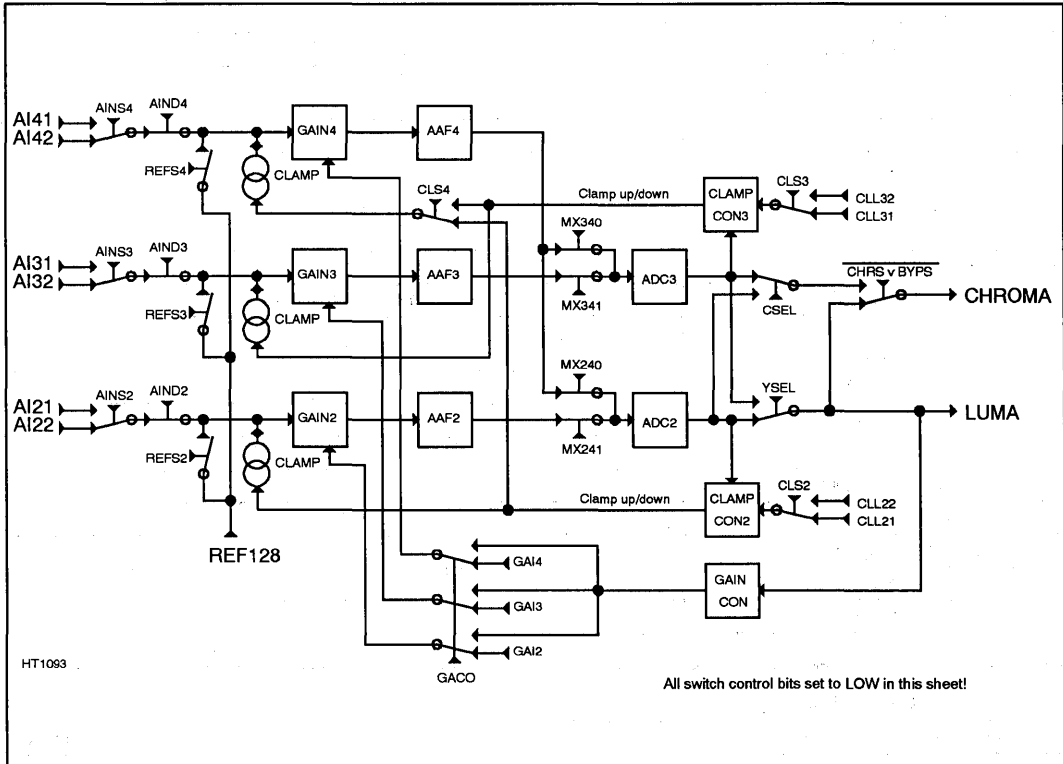

TABLE 29. SOURCE SELECTION MANAGEMENT example table

INPUT	EXAMPLE1		EXAMPLE2		EXAMPLE3		EXAMPLE4	
	SIGNAL	MODE	SIGNAL	MODE	SIGNAL	MODE	SIGNAL	MODE
AIN21	CVBS1	0	CVBS1	0	Y1	6	Y1	6
AIN22	CVBS2	1	C2	7	C2	7	CVBS2	1
AIN31	CVBS3	2	Y2		Y2		8	CVBS3
AIN32	CVBS4	3	C3	8	C3	8	CVBS4	3
AIN41	CVBS5	4	Y3		Y3		6	CVBS5
AIN42	CVBS6	5	CVBS6	5	C1	6	C1	6

# One Chip Frontend 1 (OFC1)

# SAA7110

TABLE 30. SOURCE SELECTION MANAGEMENT example sheets

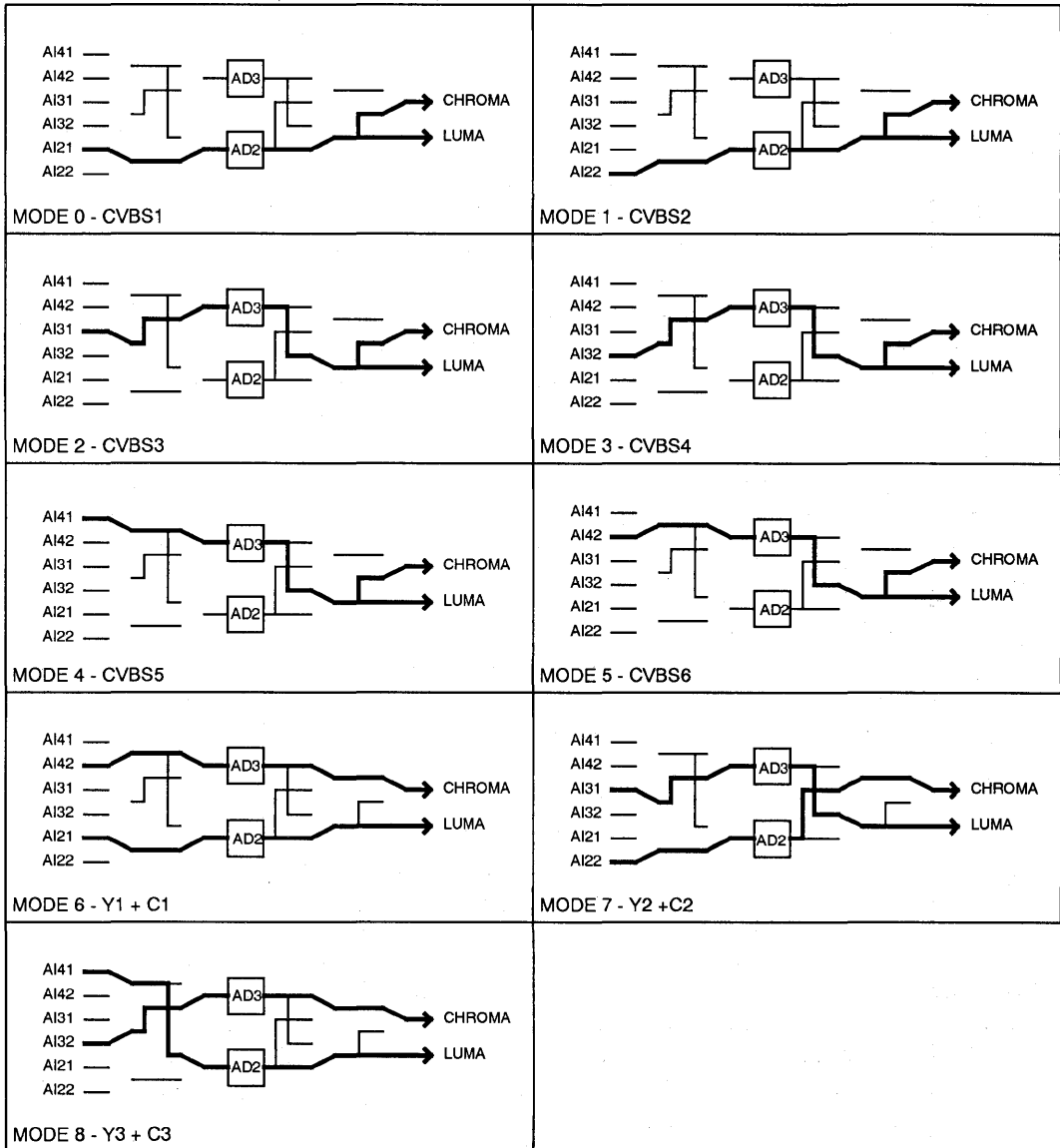

## One Chip Frontend 1 (OFC1)

SAA7110

TABLE 31. SOURCE SELECTION MANAGEMENT IIC control

MODE	0	1	2	3	4	5	6	7	8	9
AIND4	1	1	1	1	0	0	0	1	0	
AIND3	1	1	0	0	1	1	1	0	0	
AIND2	0	0	1	1	1	1	0	0	1	
FUSE1	1									
FUSE0	1									
AINS4	X	X	X	X	1	0	0	X	1	
AINS3	X	X	1	0	X	X	0	1	0	
AINS2	1	0	X	X	X	X	1	0	X	
VBC0	0									
MS34	0									
MX241	0	0	X	X	X	X	0	0	1	
MX240	1	1	X	X	X	X	1	1	0	
MS24	0									
REFS4	1	1	1	1	0	0	0	1	0	
REFS3	1	1	0	0	1	1	1	0	0	
REFS2	0	0	1	1	1	1	0	0	1	
GACO1	0	0	1	1	1	1	0	1	1	
GACO0	1	1	0	0	1	1	1	0	1	
CSEL	X	X	X	X	X	X	0	1	0	
YSEL	0	0	1	1	1	1	0	1	0	
MUYC	0									0
CLTS	0									0
MX341	X	X	0	0	1	1	1	0	0	
MX340	X	X	1	1	0	0	0	1	1	
CLS4	X	X	X	X	1	1	1	X	0	
GABL	0									
CLS3	X	X	0	0	0	0	1	0	1	
CLS2	0	0	X	X	X	X	0	1	X	
4 LSB	0011									0011
BYPS	0	0	0	0	0	0	1	1	1	
SU20h	D9h	D8h	BAh	B8h	7Ch	78h	59h	9Ah	3Ch	
SU21h	16h	16h	05h	05h	03h	03h	12h	14h	21h	
SU22h	40h	40h	91h	91h	D2h	D2h	42h	B1h	C1h	
SU2Ch	03h	03h	03h	03h	83h	83h	A3h	13h	23h	
SU06h	0XXXXXXX						1XXXXXXX			
SU30h*	44h	44h	60h	60h	60h	60h	44h	60h	44h	
Note: CLL21=65d, CLL22=128d, CLL31=65d, CLL32=128d, GAI4=15d, GAI3=15d, GAI2=15d; X set to 0 *Optional: values for AD-gain (+2LSB's gain resolution) active [not active: for all modes 40h]										

# One Chip Frontend 1 (OFC1)

# SAA7110

## 19.3 ANTI-ALIAS FILTER CURVE

FIGURE 21. ANTI-ALIAS FILTER CURVE

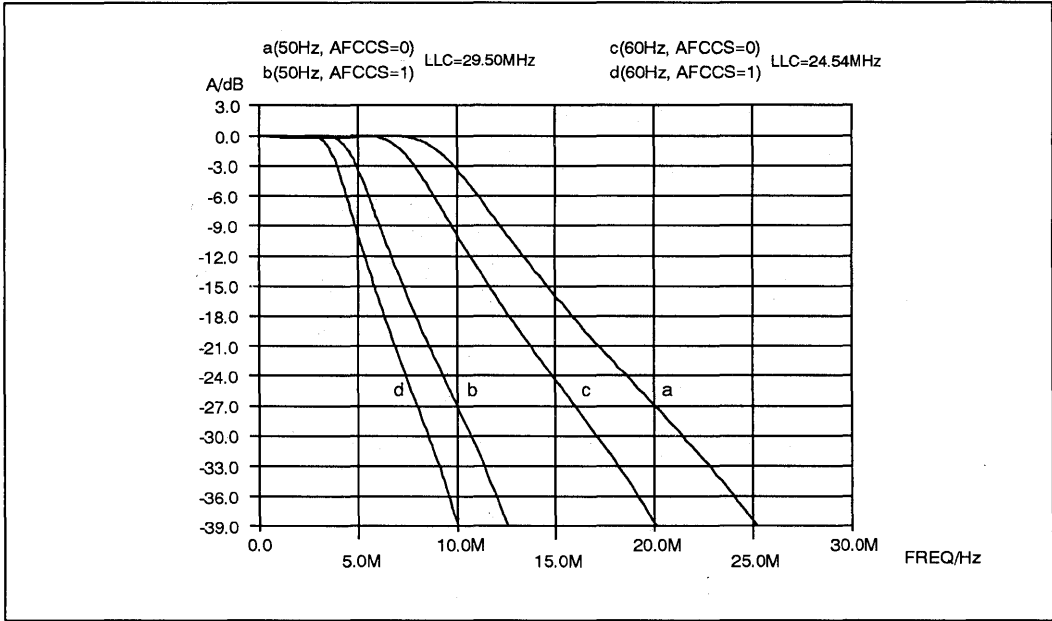

## 19.4 CORING FUNCTION

TABLE 32. CORING

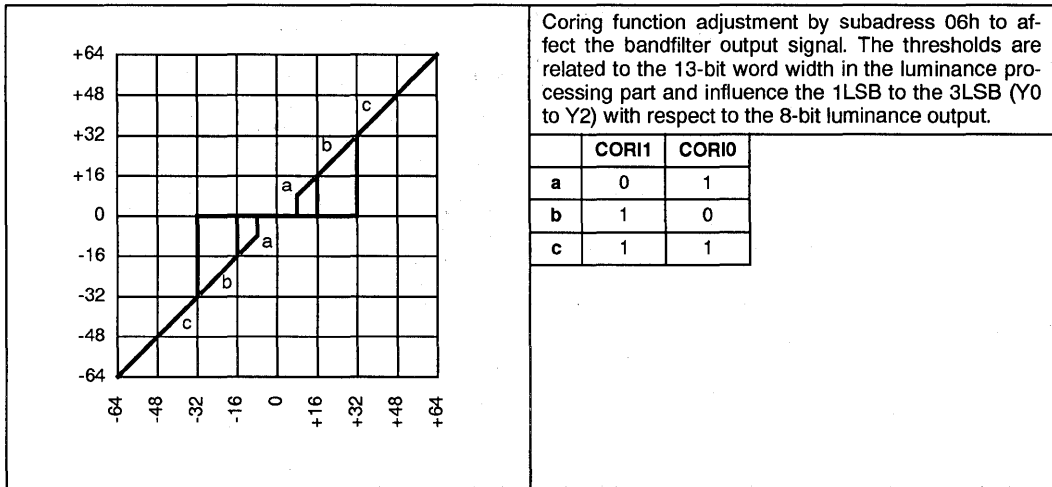

One Chip Frontend 1 (OFC1)

SAA7110

19.5 LUMINANCE FILTER CURVES

TABLE 33. LUMINANCE FILTER CURVES

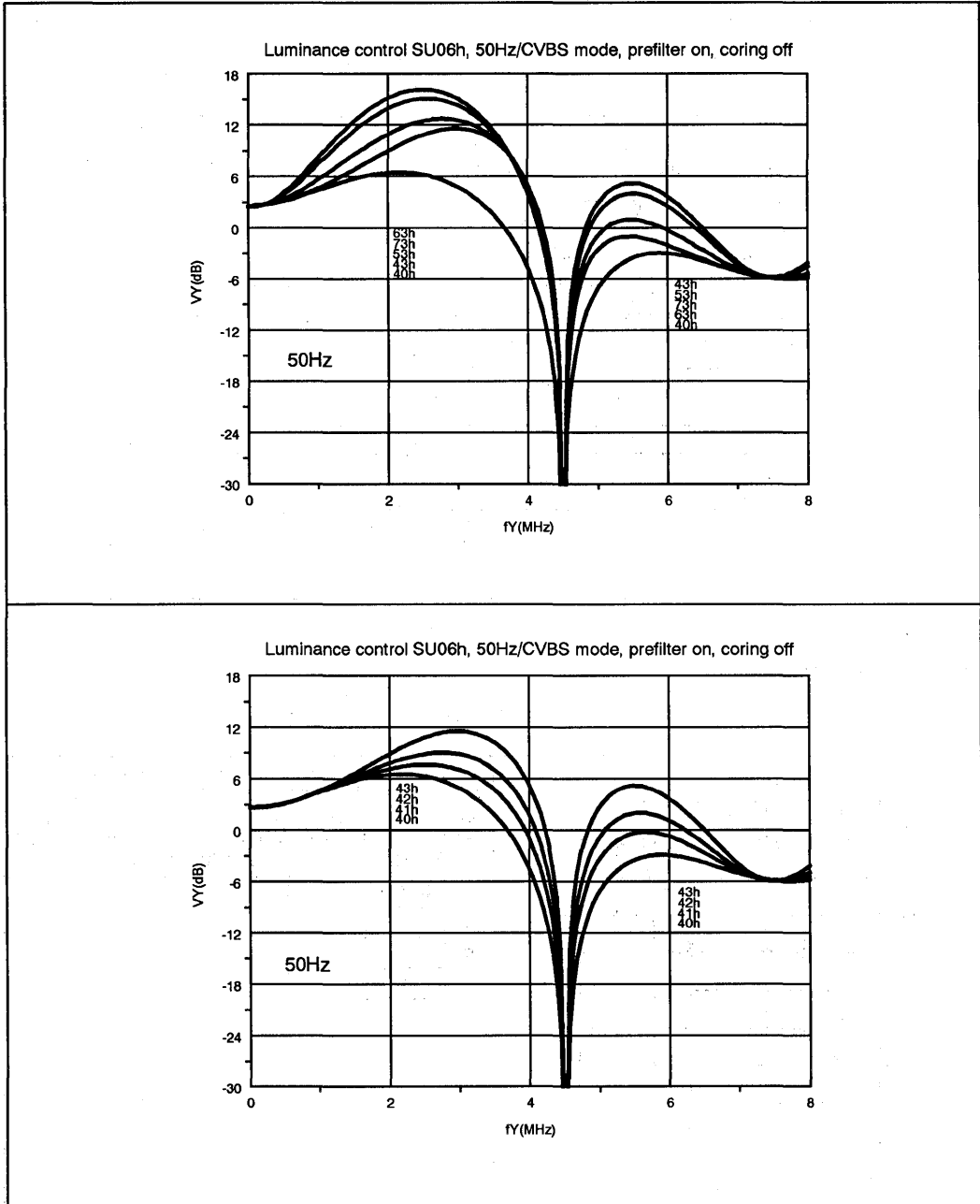



One Chip Frontend 1 (OFC1)

SAA7110

TABLE 33. LUMINANCE FILTER CURVES

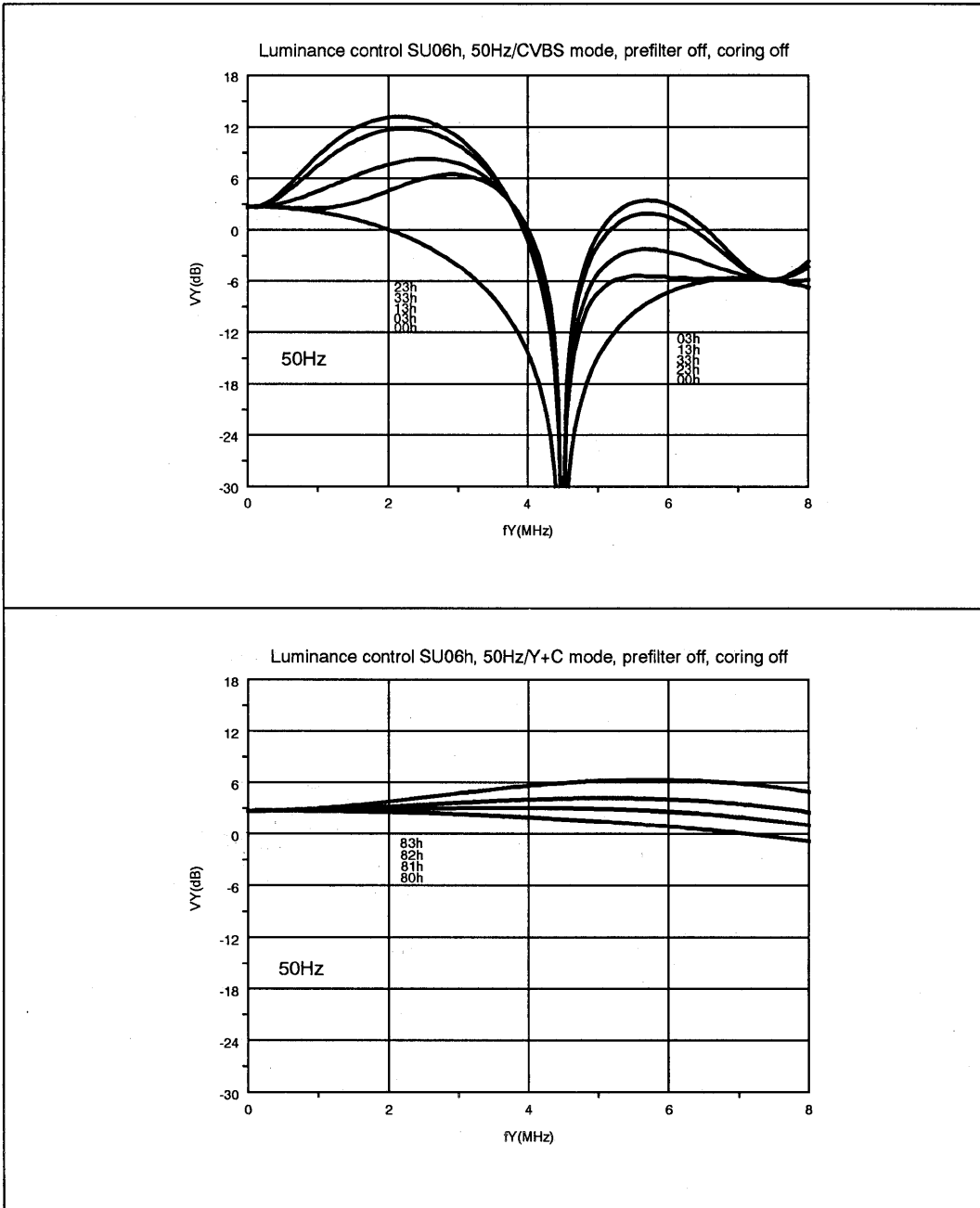

One Chip Frontend 1 (OFC1)

SAA7110

TABLE 33. LUMINANCE FILTER CURVES

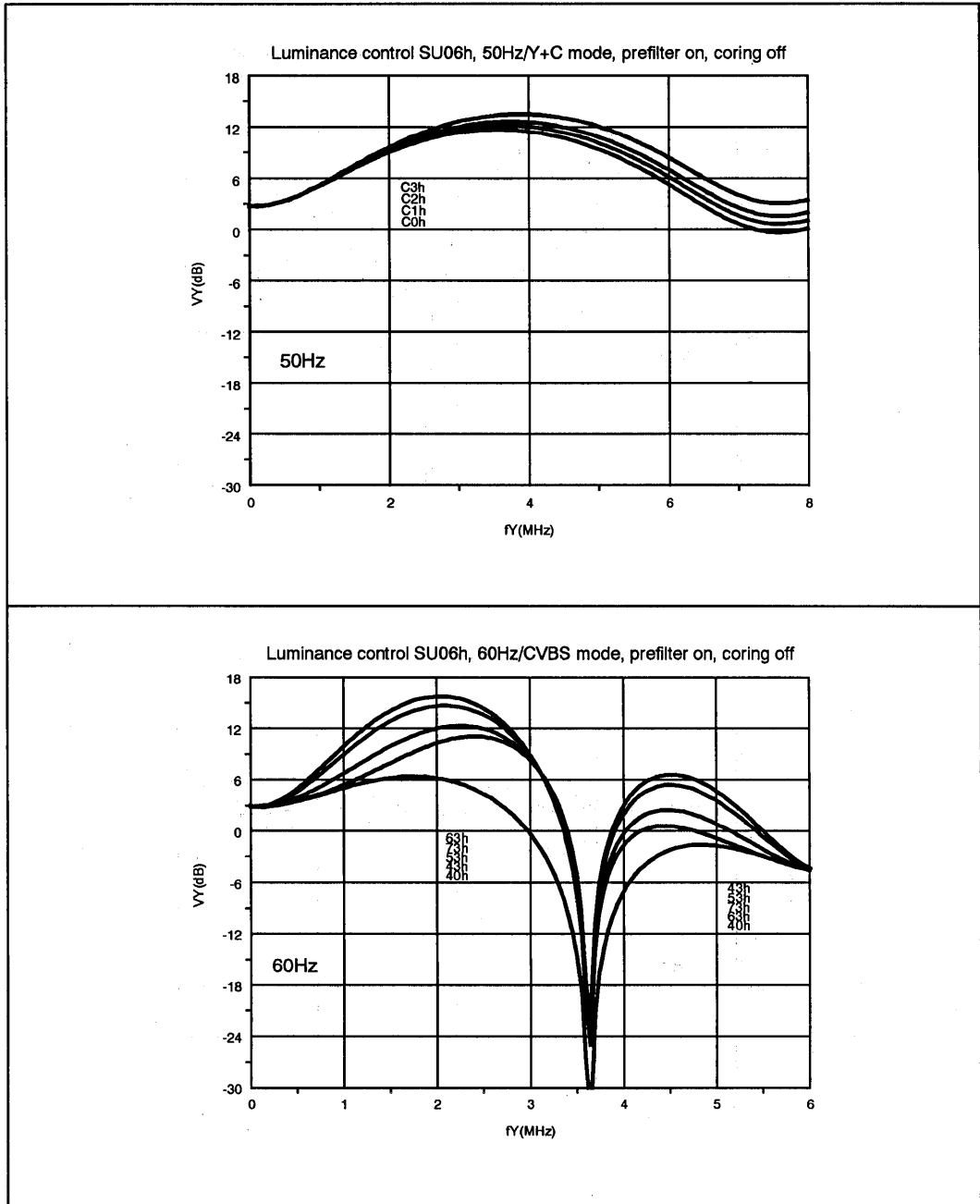

One Chip Frontend 1 (OFC1)

SAA7110

TABLE 33. LUMINANCE FILTER CURVES

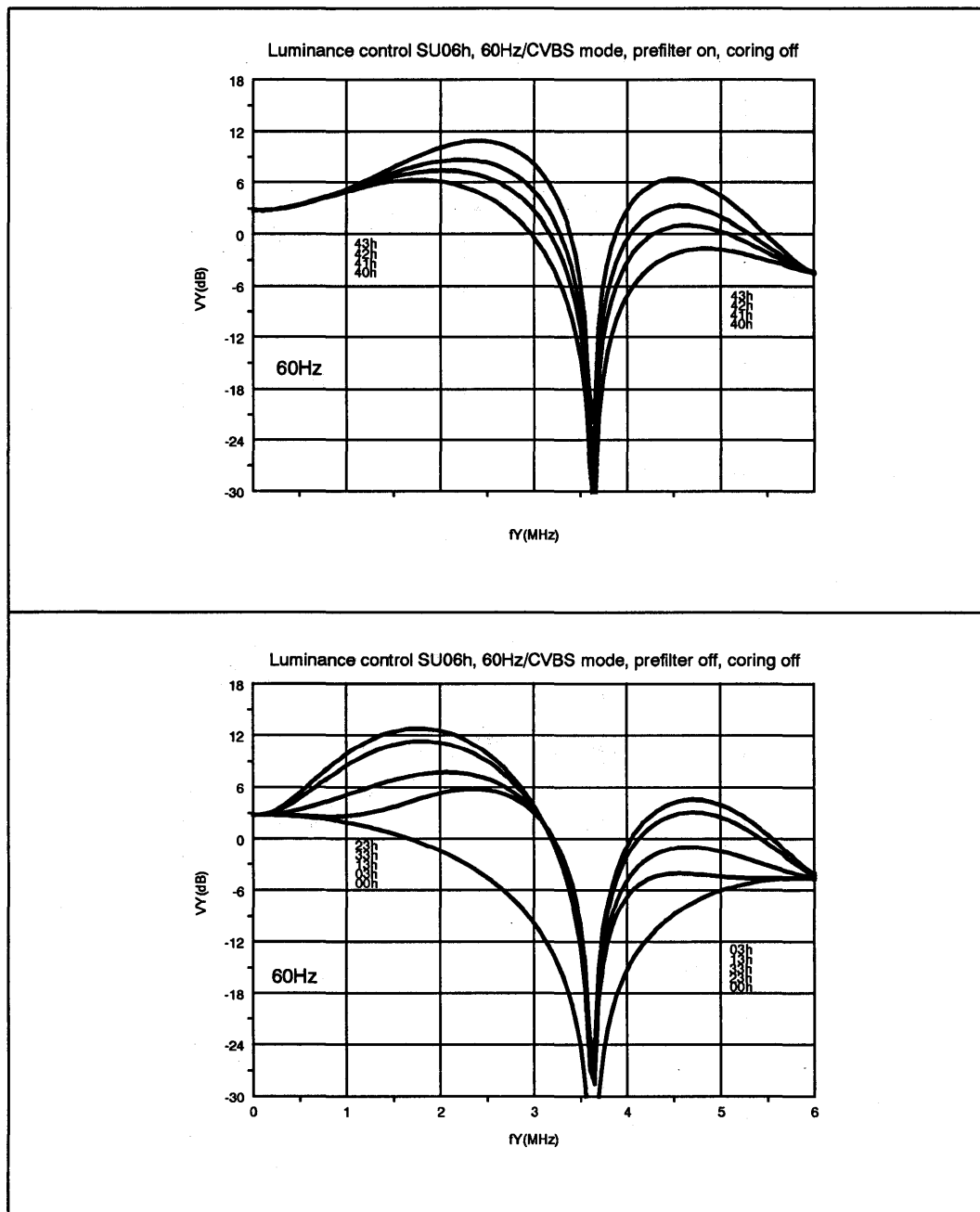

One Chip Frontend 1 (OFC1)

SAA7110

TABLE 33. LUMINANCE FILTER CURVES

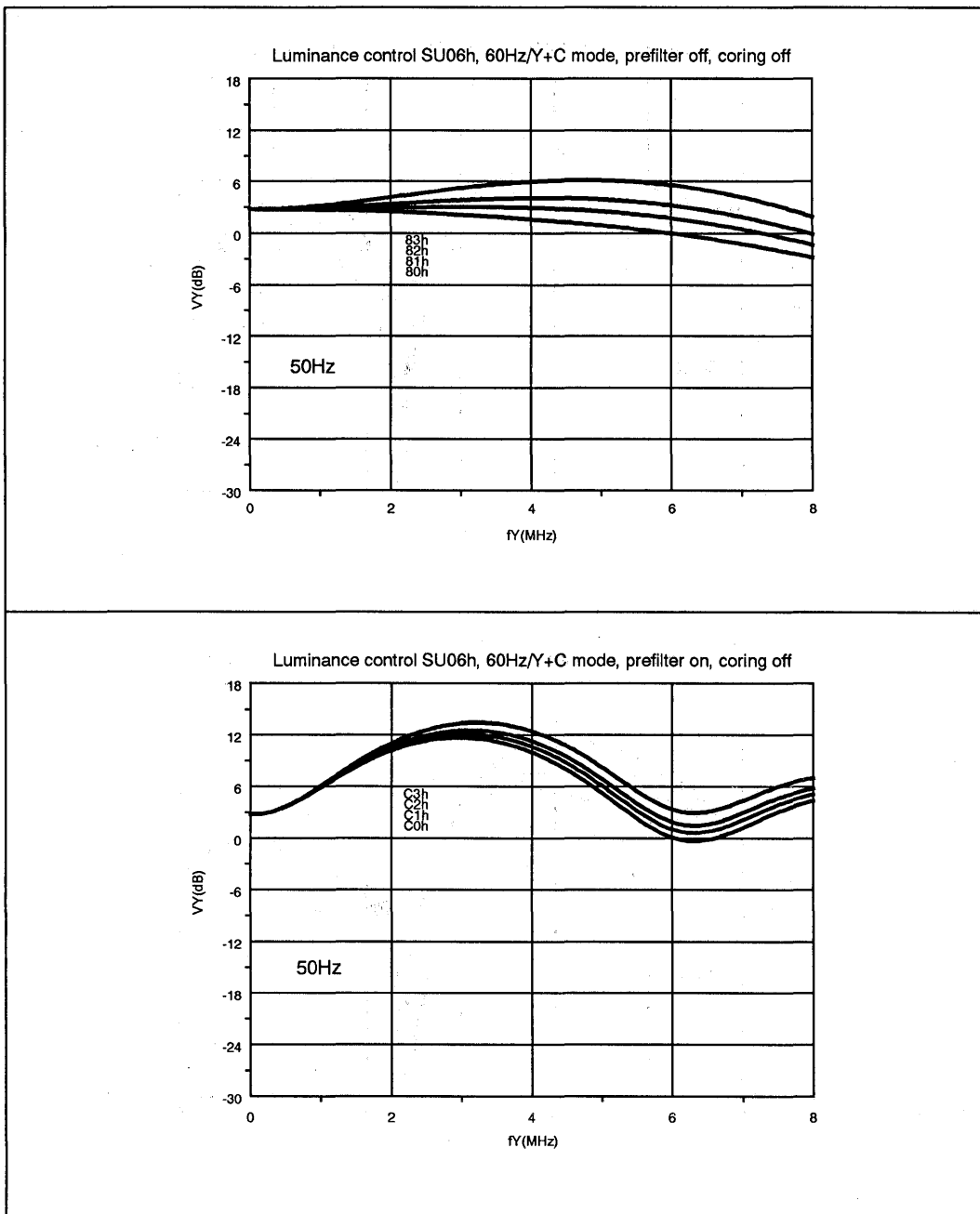

## One Chip Frontend 1 (OFC1)

SAA7110

## 20. IIC START SETUP

The following values are optimized for the EBU colour bar (100% white and 75% chrominance amplitude) input signal. The decoder output signal level fulfills the CCIR Rec.601 specification. The input of 100% color bar level is possible, but the signal (white) peak function reduces the digital luminance output. With another setup it is possible to proceed 100% color bar signal without luminance amplitude reduction. The way is to modify the AD input range for this input level by reducing the gain reference value (SBOT > 06h) and adjusting the digital Y output level with contrast and brightness control.

TABLE 34. IIC START SETUP

SUB	NAME	FUNCTION	VALUES(bin)								(hex)
			7	6	5	4	3	2	1	0	start
00	IDEL(7:0)	Increment delay	0	1	0	0	1	1	0	0	4C
01	HSYB(7:0)	Horizontal sync HSY begin 50Hz	0	0	1	1	1	1	0	0	3C
02	HSYS(7:0)	Horizontal sync HSY stop 50Hz	0	0	0	0	1	1	0	1	0D
03	HCLB(7:0)	Horizontal clamp HCL begin 50Hz	1	1	1	0	1	1	1	1	EF
04	HCLS(7:0)	Horizontal clamp HCL stop 50Hz	1	0	1	1	1	1	0	1	BD
05	HPhi(7:0)	Horizontal sync after PHI1 50Hz	1	1	1	1	0	0	0	0	F0
06	BYPS, PREF, BPSS(1:0), BFBY, CORI(1:0), APER(1:0)	Luminance control	0	0	0	0	0	0	0	0	00
07	HUEC(7:0)	Hue control	0	0	0	0	0	0	0	0	00
08	CKTQ(4:0), XXX	Colour killer threshold PAL	1	1	1	1	1	X	X	X	F8
09	CKTS(4:0), XXX	Colour killer threshold SECAM	1	1	1	1	1	X	X	X	F8
0A	PLSE(7:0)	PAL switch sensitivity	0	1	1	0	0	0	0	0	60
0B	SESE(7:0)	SECAM switch sensitivity	0	1	1	0	0	0	0	0	60
0C	COLO, LFIS(1:0), XXXXX	Gain control chrominance	0	0	0	X	X	X	X	X	00
0D	VTRC, XXX, RTSE, HRMV, SSTB, SECS	Standard/Mode control	0	X	X	X	0	1	1	0	06
0E	HPLL, XX, OEHV, OEYC, CHRS, X, GPSW	I/O and clock control	0	X	X	1	1	0	X	0	18
0F	AUFD, FSEL, SXCR, SCEN, X, YDEL(2:0)	Control #1	1	0	0	1	X	0	0	0	90
10	XXXXX, HRFs, VNOI(1:0)	Control #2	X	X	X	X	X	0	0	0	00
11	CHCV(7:0)	PAL	0	1	0	1	1	0	0	1	59
		NTSC	0	0	1	0	1	1	0	0	2C
12	SATN(7:0)	Chroma saturation	0	1	0	0	0	0	0	0	40
13	CONT(7:0)	Luminance contrast	0	1	0	0	0	1	1	0	46
14	HS6B(7:0)	Horizontal sync HSY begin 60Hz	0	1	0	0	0	0	1	0	42
15	HS6S(7:0)	Horizontal sync HSY stop 60Hz	0	0	0	1	1	0	1	0	1A
16	HC6B(7:0)	Horizontal clamp HCL begin 60Hz	1	1	1	1	1	1	1	1	FF
17	HC6S(7:0)	Horizontal clamp HCL stop 60Hz	1	1	0	1	1	0	1	0	DA
18	HP6I(7:0)	Horizontal sync after PHI1 60Hz	1	1	1	1	0	0	0	0	F0
19	BRIG(7:0)	Luminance brightness	1	0	0	0	1	0	1	1	8B
1A-1F	reserved										

## One Chip Frontend 1 (OFC1)

## SAA7110

TABLE 34. IIC START SETUP

20	AIND4, AIND3, AIND2, FUSE(1:0), AINS4, AINS3, AINS2	Analog control #1	1	1	0	1	1	0	0	1	D9	
21	VBCO, MS34, MX24(1:0), MS24, REFS4, REFS3, REFS2	Analog control #2	0	0	0	1	0	1	1	0	16	
22	GACO(1:0), CSEL, YSEL, MUYP, CLTS, MX34(1:0)	Mix control #1	0	1	0	0	0	0	0	0	40	
23	CLL21(7:0)	Clamp level control channel 2 1	0	1	0	0	0	0	0	1	41	
24	CLL22(7:0)	Clamp level control channel 2 2	1	0	0	0	0	0	0	0	80	
25	CLL31(7:0)	Clamp level control channel 3 1	0	1	0	0	0	0	0	1	41	
26	CLL32(7:0)	Clamp level control channel 3 2	1	0	0	0	0	0	0	0	80	
27	HOLD, GASL, GAI2(5:0)	Gain control analog #1	0	1	0	0	1	1	1	1	4F	
28	WIPE(7:0)	White peak control	1	1	1	1	1	1	1	0	FE	
29	SBOT(7:0)	Sync bottom control	0	0	0	0	0	0	0	1	01	
2A	IWIP(1:0), GAI3(5:0)	Gain control analog #2	1	1	0	0	1	1	1	1	CF	
2B	IGAI(1:0), GAI4(5:0)	Gain control analog #3	0	0	0	0	1	1	1	1	0F	
2C	CLS4, X, CLS3, CLS2, XX, TWO3, TWO2	Mix control #2	0	X	0	0	X	X	1	1	03	
2D	IVAL(7:0)	Integration value gain	0	0	0	0	0	0	0	1	01	
2E	VBPS(7:0)	50Hz	Vertical blanking pulse SET	1	0	0	1	1	0	1	0	9A
		60Hz		1	0	0	0	0	0	0	1	81
2F	VBPR(7:0)	50Hz	Vertical blanking pulse RESET	0	0	0	0	0	0	1	1	03
		60Hz		0	0	0	0	0	0	1	1	03
30	X, WISL, GAS3, GAD3(1:0), GAS2, GAD2(1:0)	ADCs gain control	X	1	0	0	0	0	0	0	44	
31	AOSL(1:0), WIRS, WRSE, SQPB, AFCCS, VBLKA, PULIO	Mix control #3	0	1	1	1	0	1	0	1	75	
32	VVAL(7:0)	Integration value white peak	0	0	0	0	0	0	1	0	02	
33	OFTS, X, CHSB, X, CAD2, CAD3, XX	Mix control #4	1	X	0	X	1	1	X	X	8C	
34	MUD2, MUD1, GUDL(5:0)	Gain update level	0	0	0	0	0	0	1	1	03	

Note: Values recommended for a CVBS (PAL or NTSC) signal, input AI21 via A/D channel 2 (MODE 0), and 4:2:2 CCIR output signal level; all X values must be set to LOW; HPHI and HP6I -> application dependent.

One Chip Frontend 1 (OCF1)

SAA7110

21. APPLICATION SHEET

FIGURE 22. OCF1 APPLICATION SHEET

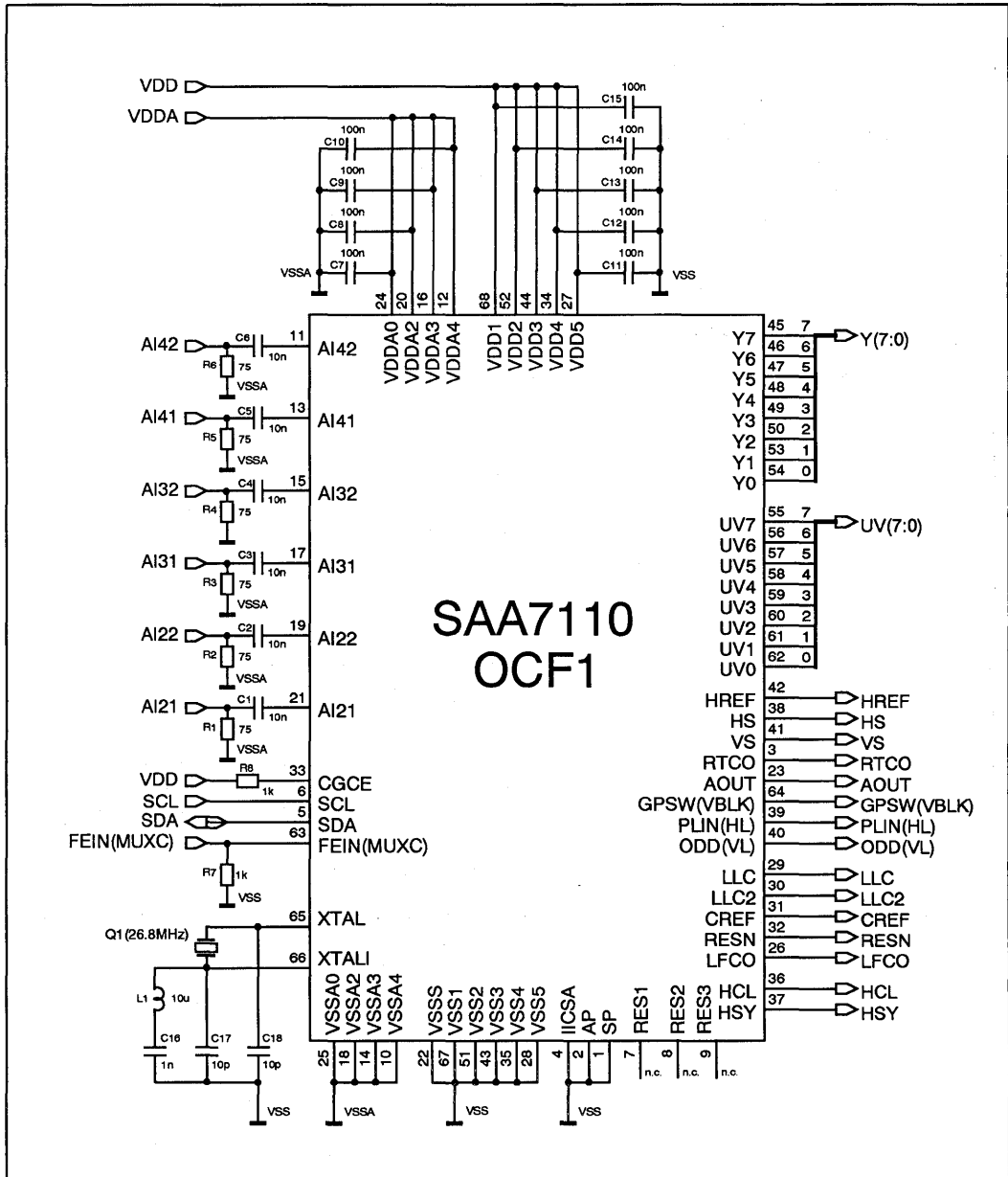

Note: Unused analog inputs should be not connected!

One Chip Frontend 1 (OFC1)

SAA7110

21.1 APPLICATION WITH EXTERNAL CGC

FIGURE 23. APPLICATION WITH EXTERNAL CGC

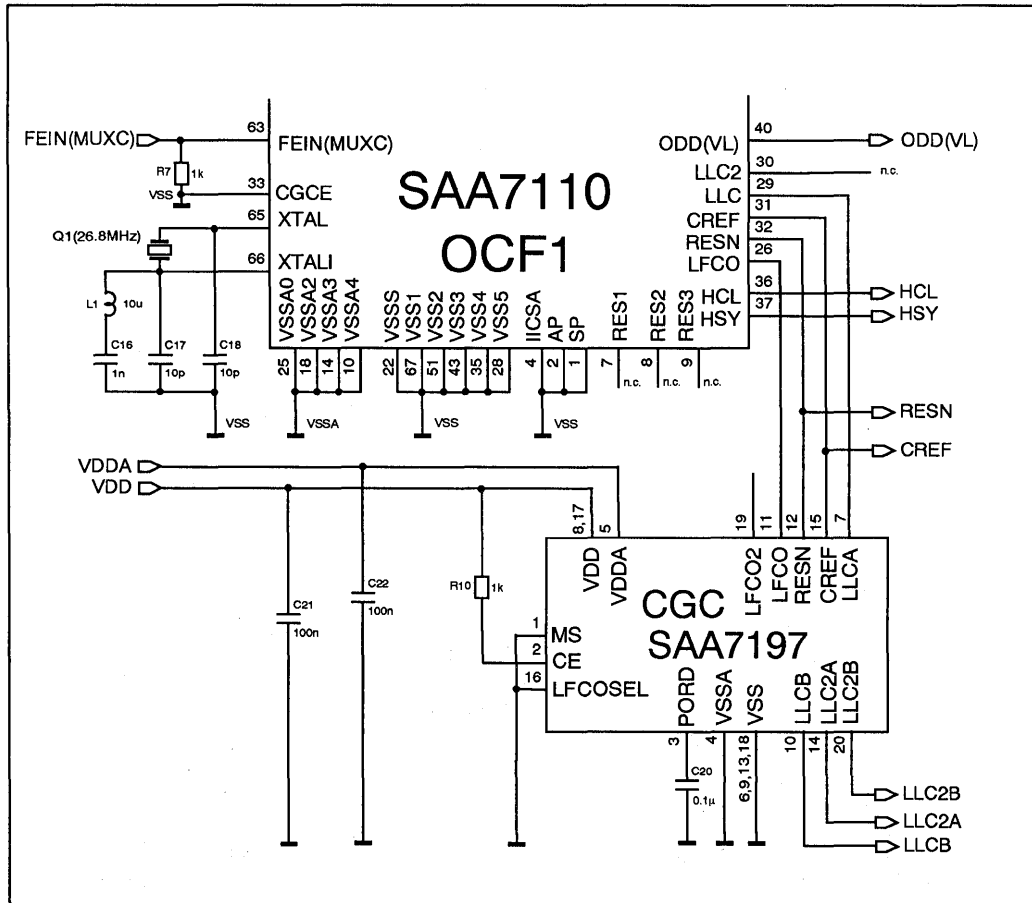

The OFC1 supports for special applications the use of an external Clock Generator Circuit (CGC, SAA7197). For normal operation the build in CGC fulfills all requirements.



One Chip Frontend 1 (OFC1)

SAA7110

22. STARTUP, SOURCE SELECT AND STANDARD DETECTION FLOW EXAMPLE

FIGURE 24. SOFTWARE FLOW EXAMPLE

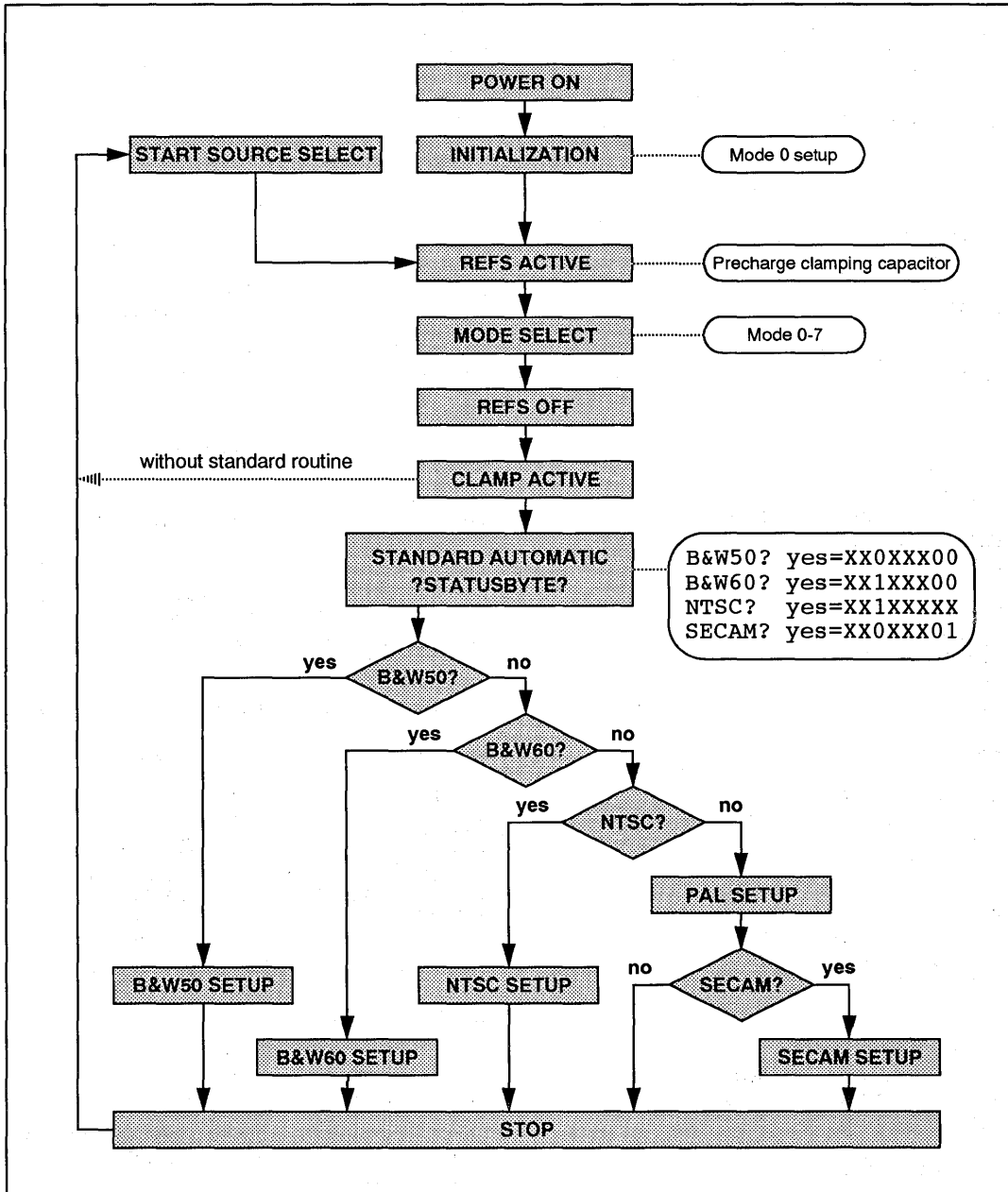

## One Chip Frontend 1 (OFC1)

SAA7110

**MODE 0 STARTUP and STANDARD Procedure**

```

SLAVE %78          !OCF1 NTSC-setup
SUB 00 WRITE
4C 3C 0D EF BD F0 00 00
F8 F8 60 60 00 06 18 90
00 2C 40 46 42 1A FF DA
F0 8B 00 00 00 00 00 00
D9 17 40 41 80 41 80 4F
FE 01 CF 0F 03 01 81 03
44 75 01 8C 03
SUB 21 WRITE 16    !REFS OFF CLAMP AKTIV

```

```

READ 1            !Status?

```

**#STANDARD**

```

IF 1 @XX0XXX00    !NO COLOR
THEN GOTO BW_50Hz
ENDIF
IF 1 @XX1XXX00    !NO COLOR
THEN GOTO BW_60Hz
ENDIF
SUB 06 WRITE 00
ENDIF
IF 1 @XX1XXXXX    !60Hz
THEN GOTO NTSC
ENDIF
IF 1 @XX0XXXXX    !50Hz
THEN GOTO PAL
ENDIF

```

**#BW\_50Hz**

```

PRINT "BLACK&WHITE"
SUB 06 WRITE 80
SUB 2E WRITE 9A    !VBPS
GOTO STOP

```

**#BW\_60Hz**

```

PRINT "BLACK&WHITE"
SUB 06 WRITE 80
SUB 2E WRITE 81    !VBPS
GOTO STOP

```

**#NTSC**

```

SUB 0D WRITE 06    !SECS -> 0
SUB 11 WRITE 2C    !CHCV
SUB 2E WRITE 81    !VBPS
PRINT "NTSC"
GOTO STOP

```

**#PAL**

```

SUB 0D WRITE 06    !SECS -> 0
SUB 11 WRITE 59    !CHCV
SUB 2E WRITE 9A    !VBPS
PAUSE %150         !150ms
IF 1 @XX0XXX01

```

```

THEN GOTO SECAM

```

```

ELSE PRINT "PAL"
GOTO STOP

```

**#SECAM**

```

SUB 0D WRITE 07    !SECS -> 1
PRINT "SECAM"
GOTO STOP

```

**#STOP****MODE 0 Source Select Procedure**

```

SLAVE %78          !OCF1
SUB 06 WRITE 00    !CVBS MODE 0
SUB 20 WRITE D9    !AI21 ACTIVE
SUB 21 WRITE 17    !REFS ON
SUB 22 WRITE 40    !AD2->LUMA and CHROMA
SUB 2C WRITE 03    !CLAMP SELECT
SUB 30 WRITE 44    !Gain AD2 active
SUB 31 WRITE 75    !AOSL -> 01b

SUB 21 WRITE 16    !REFS OFF CLAMP AKTIV

```

**MODE 1 Source Select Procedure**

```

SLAVE %78          !OCF1
SUB 06 WRITE 00    !CVBS MODE 1
SUB 20 WRITE D8    !AI22 ACTIVE
SUB 21 WRITE 17    !REFS ON
SUB 22 WRITE 40    !AD2->LUMA and CHROMA
SUB 2C WRITE 03    !CLAMP SELECT
SUB 30 WRITE 44    !Gain AD2 active
SUB 31 WRITE 75    !AOSL -> 01b

SUB 21 WRITE 16    !REFS OFF CLAMP AKTIV

```

**MODE 2 Source Select Procedure**

```

SLAVE %78          !OCF1
SUB 06 WRITE 00    !CVBS MODE 2
SUB 20 WRITE BA    !AI31 ACTIVE
SUB 21 WRITE 07    !REFS ON
SUB 22 WRITE 91    !AD3->LUMA and CHROMA
SUB 2C WRITE 03    !CLAMP SELECT
SUB 30 WRITE 60    !Gain AD3 active
SUB 31 WRITE B5    !AOSL -> 10b

SUB 21 WRITE 05    !REFS OFF CLAMP AKTIV

```

**MODE 3 Source Select Procedure**

```

SLAVE %78          !OCF1
SUB 06 WRITE 00    !CVBS MODE 3
SUB 20 WRITE B8    !AI32 ACTIVE
SUB 21 WRITE 07    !REFS ON
SUB 22 WRITE 91    !AD3->LUMA and CHROMA
SUB 2C WRITE 03    !CLAMP SELECT
SUB 30 WRITE 60    !Gain AD3 active

```

## One Chip Frontend 1 (OFC1)

SAA7110

```

SUB 31 WRITE B5      !AOSL -> 10b
SUB 21 WRITE 05      !REFS OFF CLAMP AKTIV
MODE 4 Source Select Procedure
SLAVE %78            !OCF1
SUB 06 WRITE 00      !CVBS MODE 4
SUB 20 WRITE 7C      !AI41 ACTIVE
SUB 21 WRITE 07      !REFS ON
SUB 22 WRITE D2      !AD3->LUMA and CHROMA
SUB 2C WRITE 83      !CLAMP SELECT
SUB 30 WRITE 60      !Gain AD3 active
SUB 31 WRITE B5      !AOSL -> 10b
SUB 21 WRITE 03      !REFS OFF CLAMP AKTIV
SUB 21 WRITE 27      !REFS ON
SUB 22 WRITE C1      !AD2->LUMA, AD3->CHR
SUB 2C WRITE 23      !CLAMP SELECT
SUB 30 WRITE 44      !Gain AD2 active
SUB 31 WRITE 75      !AOSL -> 01
SUB 21 WRITE 21      !REFS OFF CLAMP AKTIV

```

Space for notes:

## MODE 5 Source Select Procedure

```

SLAVE %78            !OCF1
SUB 06 WRITE 00      !CVBS MODE 5
SUB 20 WRITE 78      !AI41 ACTIVE
SUB 21 WRITE 07      !REFS ON
SUB 22 WRITE D2      !AD3->LUMA and CHROMA
SUB 2C WRITE 83      !CLAMP SELECT
SUB 30 WRITE 60      !Gain AD3 active
SUB 31 WRITE B5      !AOSL -> 10b
SUB 21 WRITE 03      !REFS OFF CLAMP AKTIV

```

## MODE 6 Source Select Procedure

```

SLAVE %78            !OCF1
SUB 06 WRITE 80      !Y+C MODE 6
SUB 20 WRITE 59      !AI21=Y, AI42=C
SUB 21 WRITE 17      !REFS ON
SUB 22 WRITE 42      !AD2->LUMA, AD3->CHR
SUB 2C WRITE A3      !CLAMP SELECT
SUB 30 WRITE 44      !Gain AD2 active
SUB 31 WRITE 75      !AOSL -> 01
SUB 21 WRITE 12      !REFS OFF CLAMP AKTIV

```

## MODE 7 Source Select Procedure

```

SLAVE %78            !OCF1
SUB 06 WRITE 80      !Y+C MODE 7
SUB 20 WRITE 9A      !AI31=Y, AI22=C
SUB 21 WRITE 17      !REFS ON
SUB 22 WRITE B1      !AD3->LUMA, AD2->CHR
SUB 2C WRITE 13      !CLAMP SELECT
SUB 30 WRITE 60      !Gain AD3 active
SUB 31 WRITE B5      !AOSL -> 10b
SUB 21 WRITE 14      !REFS OFF CLAMP AKTIV

```

## MODE 8 Source Select Procedure

```

SLAVE %78            !OCF1
SUB 06 WRITE 80      !Y+C MODE 8
SUB 20 WRITE 3C      !AI41=Y, AI32=C

```

## SAA7110 programming example

### SAA7110 PROGRAMMING EXAMPLE

Slave address is 9C (IICSA=0) or 9E (IICSA=1)

SUB ADDR	DATA	FUNCTION
00	4C	Increment Delay
01	3F	Begin HSY (50Hz)
02	0D	End HSY (50Hz)
03	EF	Begin HCL (50Hz)
04	BD	End HCL (50Hz)
05	F0	Horizontal Sync after PHI1 (50Hz)
06	01	Luminance Control
07	02	Hue Control
08	F8	QUAM Color Killer Threshold
09	F8	SECAM Color Killer Threshold
0A	90	PAL Sensitivity Switch
0B	90	SECAM Sensitivity Switch
0C	00	AGC Loop Time Constant Control/Color Killer ON/OFF (MSB)
0D	86	Standard/Mode Control
0E	18	I/O and Clock Control
0F	B0	Control #1
10	00	Control #2
11	59	Chroma Gain Reference
12	40	Chroma Saturation
13	55	Luminance Contrast
14	42	Begin HSY (60Hz)
15	1A	End HSY (60Hz)
16	FC	Begin HCL (60Hz)
17	D3	End HCL (60Hz)
18	E2	Horizontal Sync after PHI1 (60Hz)
19	AA	Luminance Brightness
1A	00	Reserved
1B	00	Reserved
1C	00	Reserved
1D	00	Reserved
1E	00	Reserved
1F	00	Reserved
20	7A	Analog Control #1
21	23	Analog Control #2
22	C1	Mix Control #1
23	40	Clamp Level Control 21
24	80	Clamp Level Control 22
25	40	Clamp Level Control 31
26	80	Clamp Level Control 32
27	41	Gain Control #1
28	FE	White Peak Control
29	01	Sync Bottom Control
2A	C5	Gain Control #2
2B	0F	Gain Control #3
2C	23	Mix Control #2
2D	01	Integration Value Gain
2E	9A	Vertical Blank Pulse SET
2F	03	Vertical Blank Pulse RESET
30	40	ADC Gain Control
31	75	Mix Control #3
32	02	Integration Value White Peak
33	8C	Mix Control #4
34	03	Gain Up-date Level

# Digital video to PCI interface

# SAA7116

## FEATURES

- Full multistandard video input capability (with Philips Video Decoder Chipset)
- Image resolution up to 768 × 576 (full PAL or SECAM resolution)
- Data formats:
  - RGB 15 packed
  - RGB 24 packed
  - YUV 16 packed; CCIR 601 4:2:2
  - YUV 9 planar; Indeo® DVI compatible
  - YUV 12 planar
  - YUV 16 planar
- Capture Chipset:
  - SAA7151B (CCIR decoder)
  - SAA7191B (square pixel decoder)
  - SAA7196 (square pixel decoder with scaler and clock)
  - SAA7110 (one chip decoder)
  - SAA7186 (digital video scaler)

- 1024 byte FIFO memory size
- Programmable minimum burst transfer size
- Even and odd fields can be sent to independent destinations
- Zero wait state PCI burst writes
- Field rate sent to target can be throttled (field masking)
- 160-pin plastic quad flat pack
- Power consumption approximately 1.0 Watt

## APPLICATIONS

- Real-time video capture to graphics RAM and/or CPU RAM
- PCI multi-media designs
- Feed video to all relevant PC destinations (frame buffers and SW/HW codecs)

## GENERAL DESCRIPTION

The SAA7116 is a video capture IC that serves as an interface between the Philips video capture chipset and the PCI bus. The digitized video which can incorporate filtering, scaling and translation is presented to the IC in one of three formats: RGB 5:5:5, YUV 4:2:2, or RGB 8:8:8. The SAA7116 contains FIFOs to decouple the real time video data stream from the PCI bus and provides DMA channels to deliver the video data in packed format (i.e., for local display) and in planar format (i.e., for compression). The SAA7116 is both a PCI bus master and slave. It operates in master mode to transfer video data across the PCI bus and operates in slave mode to program local registers.

## ORDERING INFORMATION

EXTENDED TYPE NUMBER	PACKAGE			
	PINS	PIN POSITION	MATERIAL	CODE
SAA7116H	160	QFP	Plastic	SOT225

## BLOCK DIAGRAM

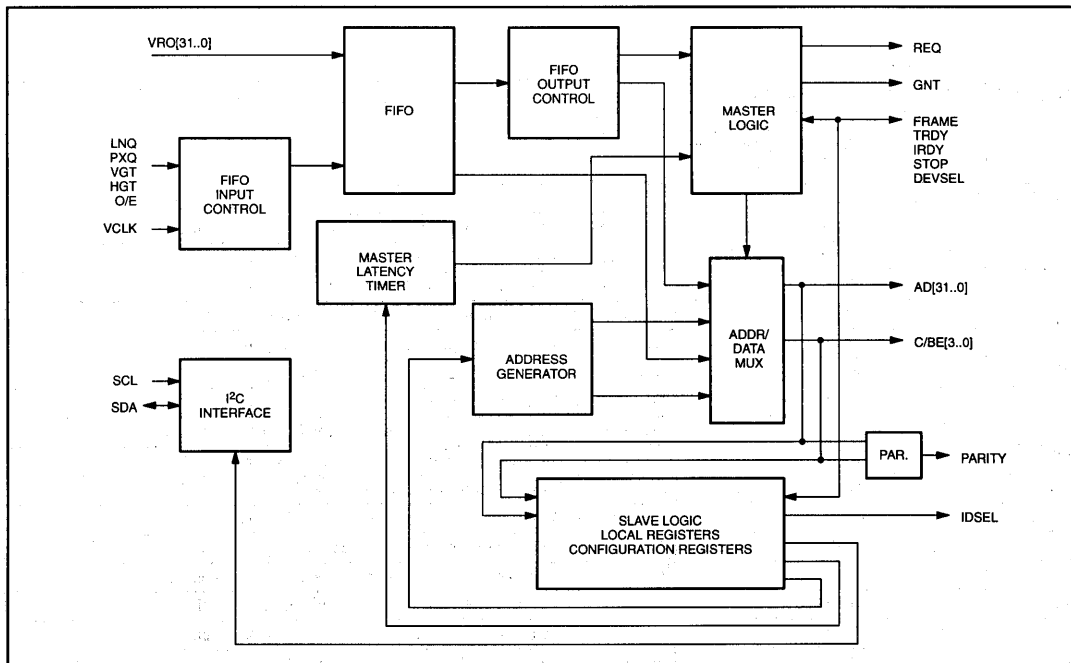

©Indeo is a registered trademark of Intel Corporation.

## Digital video to PCI interface

SAA7116

## PIN CONFIGURATION

Pin	Function	Pin	Function	Pin	Function	Pin	Function
1	V <sub>CC</sub>	41	GND	81	V <sub>CC</sub>	121	GND
2	V <sub>CC</sub>	42	AD23	82	AD13	122	GND
3	NC	43	V <sub>CC</sub>	83	V <sub>CC</sub>	123	PXQ
4	NC	44	AD22	84	AD12	124	LNQ
5	NC	45	GND	85	AD11	125	HGT
6	NC	46	AD21	86	GND	126	VGT
7	VCLK	47	AD20	87	AD10	127	OE
8	V <sub>CC</sub>	48	V <sub>CC</sub>	88	V <sub>CC</sub>	128	VRO6
9	VRSTN	49	AD19	89	AD9	129	VRO9
10	GND	50	GND	90	AD8	130	VRO10
11	GND	51	AD18	91	GND	131	VRO11
12	SCL	52	AD17	92	CBE0#	132	VRO12
13	SDA	53	V <sub>CC</sub>	93	V <sub>CC</sub>	133	VRO13
14	NC	54	AD16	94	AD7	134	V <sub>CC</sub>
15	V <sub>CC</sub>	55	GND	95	AD6	135	GND
16	INT#	56	CBE2#	96	GND	136	V <sub>CC</sub>
17	PRST#	57	FRAME#	97	AD5	137	VRO137
18	PCLK	58	V <sub>CC</sub>	98	V <sub>CC</sub>	138	VRO138
19	GNT#	59	GND	99	V <sub>CC</sub>	139	VRO139
20	V <sub>CC</sub>	60	GND	100	AD4	140	V <sub>CC</sub>
21	GND	61	V <sub>CC</sub>	101	AD3	141	GND
22	GND	62	IRDY#	102	GND	142	GND
23	REQ#	63	TRDY#	103	GND	143	V <sub>CC</sub>
24	AD31	64	V <sub>CC</sub>	104	AD2	144	VRO17
25	V <sub>CC</sub>	65	GND	105	V <sub>CC</sub>	145	VRO18
26	AD30	66	V <sub>CC</sub>	106	AD1	146	VRO19
27	GND	67	DEVSEL#	107	AD0	147	VRO20
28	AD29	68	STOP#	108	GND	148	VRO21
29	AD28	69	GND	109	GND	149	VRO22
30	V <sub>CC</sub>	70	NC	110	INT_PIN0	150	VRO23
31	AD27	71	V <sub>CC</sub>	111	INT_PIN1	151	VRO24
32	GND	72	NC	112	INT_PIN2	152	VRO25
33	AD26	73	PAR	113	V <sub>CC</sub>	153	VRO26
34	AD25	74	GND	114	NC	154	VRO27
35	V <sub>CC</sub>	75	CBE1#	115	NC	155	VRO28
36	AD24	76	V <sub>CC</sub>	116	NC	156	VRO29
37	GND	77	AD15	117	TN	157	VRO30
38	CBE3#	78	AD14	118	PO	158	VRO31
39	IDSEL	79	GND	119	V <sub>CC</sub>	159	GND
40	V <sub>CC</sub>	80	GND	120	V <sub>CC</sub>	160	GND

NOTE: # means Active LOW

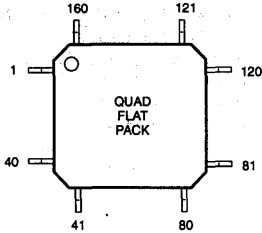

## PIN DESCRIPTIONS

SYMBOL <sup>3</sup>	PIN NUMBER	SIGNAL TYPE		DESCRIPTION
		INPUT/OUTPUT TYPE <sup>2</sup>	SIGNAL DIRECTION	
<b>PCI Address and Data Pins</b>				
AD0	107	3-State	I/O	Address and Data are multiplexed on the same PCI pins. bit 0
AD1	106	3-State	I/O	Address and Data are multiplexed on the same PCI pins. bit 1
AD2	104	3-State	I/O	Address and Data are multiplexed on the same PCI pins. bit 2
AD3	101	3-State	I/O	Address and Data are multiplexed on the same PCI pins. bit 3
AD4	100	3-State	I/O	Address and Data are multiplexed on the same PCI pins. bit 4
AD5	97	3-State	I/O	Address and Data are multiplexed on the same PCI pins. bit 5
AD6	95	3-State	I/O	Address and Data are multiplexed on the same PCI pins. bit 6
AD7	94	3-State	I/O	Address and Data are multiplexed on the same PCI pins. bit 7
AD8	90	3-State	I/O	Address and Data are multiplexed on the same PCI pins. bit 8
AD9	89	3-State	I/O	Address and Data are multiplexed on the same PCI pins. bit 9
AD10	87	3-State	I/O	Address and Data are multiplexed on the same PCI pins. bit 10
AD11	85	3-State	I/O	Address and Data are multiplexed on the same PCI pins. bit 11
AD12	84	3-State	I/O	Address and Data are multiplexed on the same PCI pins. bit 12
AD13	82	3-State	I/O	Address and Data are multiplexed on the same PCI pins. bit 13
AD14	78	3-State	I/O	Address and Data are multiplexed on the same PCI pins. bit 14
AD15	77	3-State	I/O	Address and Data are multiplexed on the same PCI pins. bit 15
AD16	54	3-State	I/O	Address and Data are multiplexed on the same PCI pins. bit 16

Digital video to PCI interface

SAA7116

SYMBOL <sup>3</sup>	PIN NUMBER	SIGNAL TYPE		DESCRIPTION
		INPUT/OUTPUT TYPE <sup>2</sup>	SIGNAL DIRECTION	
AD17	52	3-State	I/O	Address and Data are multiplexed on the same PCI pins. bit 17
AD18	51	3-State	I/O	Address and Data are multiplexed on the same PCI pins. bit 18
AD19	49	3-State	I/O	Address and Data are multiplexed on the same PCI pins. bit 19
AD20	47	3-State	I/O	Address and Data are multiplexed on the same PCI pins. bit 20
AD21	46	3-State	I/O	Address and Data are multiplexed on the same PCI pins. bit 21
AD22	44	3-State	I/O	Address and Data are multiplexed on the same PCI pins. bit 22
AD23	42	3-State	I/O	Address and Data are multiplexed on the same PCI pins. bit 23
AD24	36	3-State	I/O	Address and Data are multiplexed on the same PCI pins. bit 24
AD25	34	3-State	I/O	Address and Data are multiplexed on the same PCI pins. bit 25
AD26	33	3-State	I/O	Address and Data are multiplexed on the same PCI pins. bit 26
AD27	31	3-State	I/O	Address and Data are multiplexed on the same PCI pins. bit 27
AD28	29	3-State	I/O	Address and Data are multiplexed on the same PCI pins. bit 28
AD29	28	3-State	I/O	Address and Data are multiplexed on the same PCI pins. bit 29
AD30	26	3-State	I/O	Address and Data are multiplexed on the same PCI pins. bit 30
AD31	24	3-State	I/O	Address and Data are multiplexed on the same PCI pins. bit 31
C/BE3#	38	3-State	I/O	Bus Command and Byte Enables are multiplexed on the same PCI pins. Lane 3
C/BE2#	56	3-State	I/O	Bus Command and Byte Enables are multiplexed on the same PCI pins. Lane 2
C/BE1#	75	3-State	I/O	Bus Command and Byte Enables are multiplexed on the same PCI pins. Lane 1
C/BE0#	92	3-State	I/O	Bus Command and Byte Enables are multiplexed on the same PCI pins. Lane 0
PAR	73	3-State	I/O	Parity is even parity across AD[31..0] and C/BE[3..0]#. PAR is stable and valid one clock after the address phase.
<b>PCI Interface Control Pins</b>				
FRAME#	57	s/t/s	I/O	Cycle Frame is driven to indicate the beginning and duration of an access.
IRDY#	62	s/t/s	I/O	Initiator Ready indicates the ability to complete the current data phase of the transaction as busmaster.
TRDY#	63	s/t/s	I/O	Target Ready indicates the ability to complete the current data phase of the transaction as receiver.
STOP#	68	s/t/s	I/O	Stop indicates the current target is requesting the master to stop the current transaction.
IDSEL	39	I	I	Initialization device Select is used as a chip select during configuration read and write transactions.
DEVSEL#	67	s/t/s	I/O	Device Select, when actively driven, indicates the driving device has decoded its address as the target of the current access.
<b>PCI System Control Pins</b>				
PRST#	17	I	I	PCI Reset on PCI bus. If PRST# is asserted, all PCI output signals are 3-stated.
PCLK	18	I	I	PCI Clock provides timing for all transactions on PCI and is an input. All other PCI signals, except PRST#, INTA#, INTB#, INTC# AND INTD#, are sampled on the rising edge of PCLK, and all other timing parameters are defined with respect to this edge.
INT_PIN0	110	I	I	Interrupt address designation, defines PCI interrupt number. Do not connect.
INT_PIN1	111	I	I	Interrupt address designation, defines PCI interrupt number. Do not connect.
INT_PIN2	112	I	I	Interrupt address designation, defines PCI interrupt number. Do not connect.
INT#	16	OD	O	PCI Interrupt is used to request an interrupt. Interrupt number is defined by interrupt address pins 110, 111, 112.
REQ#	23	3-State	O	Request to the arbiter, that this device desires use of the bus.
GNT#	19	3-State	I	Grant indicates that access to the bus has been granted.

## Digital video to PCI interface

SAA7116

SYMBOL <sup>3</sup>	PIN NUMBER	SIGNAL TYPE		DESCRIPTION
		INPUT/ OUTPUT TYPE <sup>2</sup>	SIGNAL DIRECTION	
<b>Video Pins</b>				
VRO31	158			Video Data from Video input source, e.g., SAA7196 bit 31
VRO30	157			Video Data from Video input source, e.g., SAA7196 bit 30
VRO29	156			Video Data from Video input source, e.g., SAA7196 bit 29
VRO28	155			Video Data from Video input source, e.g., SAA7196 bit 28
VRO27	154			Video Data from Video input source, e.g., SAA7196 bit 27
VRO26	153			Video Data from Video input source, e.g., SAA7196 bit 26
VRO25	152			Video Data from Video input source, e.g., SAA7196 bit 25
VRO24	151			Video Data from Video input source, e.g., SAA7196 bit 24
VRO23	150			Video Data from Video input source, e.g., SAA7196 bit 23
VRO22	149			Video Data from Video input source, e.g., SAA7196 bit 22
VRO21	148			Video Data from Video input source, e.g., SAA7196 bit 21
VRO20	147			Video Data from Video input source, e.g., SAA7196 bit 20
VRO19	146			Video Data from Video input source, e.g., SAA7196 bit 19
VRO18	145			Video Data from Video input source, e.g., SAA7196 bit 18
VRO17	144			Video Data from Video input source, e.g., SAA7196 bit 17
VRO16	139			Video Data from Video input source, e.g., SAA7196 bit 16
VRO15	138			Video Data from Video input source, e.g., SAA7196 bit 15
VRO14	137			Video Data from Video input source, e.g., SAA7196 bit 14
VRO13	133			Video Data from Video input source, e.g., SAA7196 bit 13
VRO12	132			Video Data from Video input source, e.g., SAA7196 bit 12
VRO11	131			Video Data from Video input source, e.g., SAA7196 bit 11
VRO10	130			Video Data from Video input source, e.g., SAA7196 bit 10
VRO9	129			Video Data from Video input source, e.g., SAA7196 bit 9
VRO8	128			Video Data from Video input source, e.g., SAA7196 bit 8
<b>Video Control</b>				
PXQ	123			Pixel Qualifier, e.g., from VRO0 of SAA7196
LQN	124			Line Qualifier, e.g., from VRO1 of SAA7196
VGT	126			Vertical Gate signal, e.g., from VRO5 of SAA7196
HGT	125			Horizontal Gate signal, e.g., from VRO4 of SAA7196
SDA	13	OC	I/O	Data signal of I <sup>2</sup> C bus
SCL	12	OC	I/O	Clock signal of I <sup>2</sup> C bus, single master operation only
OE	127			Odd-even field indicator, e.g., from VRO6 of SAA7196
VCLK	7			Video input clock, e.g., same as VCLK pin of SAA7196
VRSTN#	9		O	Video Reset; to reset video capture device, e.g., SAA7196
TN	117			Test Pin, pull high or leave unconnected for normal operation.
PO	118		O	Test Pin, don't connect.



## Digital video to PCI interface

SAA7116

SYMBOL <sup>3</sup>	PIN NUMBER	SIGNAL TYPE		DESCRIPTION
		INPUT/OUTPUT TYPE <sup>2</sup>	SIGNAL DIRECTION	
<b>Miscellaneous</b>				
VCC5	1, 2, 8, 15, 20, 25, 30, 35, 40, 43, 48, 53, 58, 61, 64, 66, 71, 76, 81, 83, 88, 93, 98, 99, 105, 113, 119, 120, 134, 140, 143			Supply power
GND	10, 11, 21, 22, 27, 32, 37, 41, 45, 50, 55, 59, 60, 65, 69, 74, 79, 80, 86, 91, 96, 102, 103, 108, 109, 121, 122, 135, 141, 142, 159, 160			Ground
NC	3, 4, 5, 6, 14, 70, 72, 114, 115, 116, 161			No Connection

**NOTES:**

## 2. PCI Signal Type Definitions:

I *Input* is a standard input-only signal.O *Totem Pole Output* is a standard active driver.3-State *3-State* is a bi-directional, 3-State input/output pin.s/t/s *Sustained 3-State* is an active low 3-State signal owned and driven by one and only one agent at a time. The agent that drives an s/t/s pin low must drive it high for at least one clock before letting it float. A new agent cannot start driving a s/t/s signal any sooner than one clock after the previous owner 3-states it. A pullup is required to sustain the inactive state until another agent drives it, and must be provided by the control resource.OD *Open Drain* allows multiple devices to share as a wire-OR.OC *Open Collector*

## 3. The symbol # at the end of a signal name indicates that the active state occurs when the signal is at a low voltage.

# Digital video to PCI interface

# SAA7116

## 1.0 INTRODUCTION

### 1.1 Global Overview

Figure 3 is a block diagram of a Multimedia System. The SAA7116 IC along with the Philips video capture chipset provide the solution for the Capture portion of this diagram.

The SAA7116 is a video capture IC that serves as an interface between the Philips video capture chipset and the PCI bus. The Philips video capture chipset provides digitized, translated, filtered and scaled data to the SAA7116 IC in one of three formats: RGB 5-5-5, YUV 4:2:2, or RBG 8-8-8. The SAA7116 contains FIFOs to decouple the real time input video data stream from the PCI bus and provides DMA channels to deliver the video data in packed format (i.e., for local display) and planar format (i.e., for compression).

The SAA7116 is both a PCI bus master and slave. It operates in master mode to transfer

video data across the PCI bus and operates in slave mode to program local control registers of SAA7116.

#### 1.1.1 Input Interface Description

The Philips video capture chipset receives an NTSC, PAL, SECAM composite interlaced or non-interlaced analog video signal, provides analog to digital conversion, NTSC to RGB/YUV translation, and image filtering and scaling. The Philips video capture chipset, e.g., TDA8708A and SAA7196, outputs the video data to the SAA7116 IC in one of three formats: YUV 4:2:2 (16 bit), RGB 5-5-5 (15 bit) or RGB 8-8-8 (24 bit).

#### 1.1.2 Output Interface Requirements

During active capturing of video data, the master PCI state machine will request the bus once image data has been received and an appropriate address has been generated. It will generate burst writes of video data onto the PCI bus to frame buffer memory or

system memory as specified by the local DMA channel control registers.

There are six DMA address registers. The DMA address and stride registers can be programmed to send even and odd fields of an interlaced video stream to the same location or even fields to one location and odd fields to another. Data is transferred in both packed and planar modes. Data format and resolution can be programmed on a field by field basis.

## 1.2 Reference Documents

Philips Desktop Video Data Handbook 1994

PCI Local Bus Specification

Obtain from PCI Special Interest Group

(503)696-6111 – Help Line

(800)433-5177 – USA only documentation

(503)797-4207 – outside USA documentation

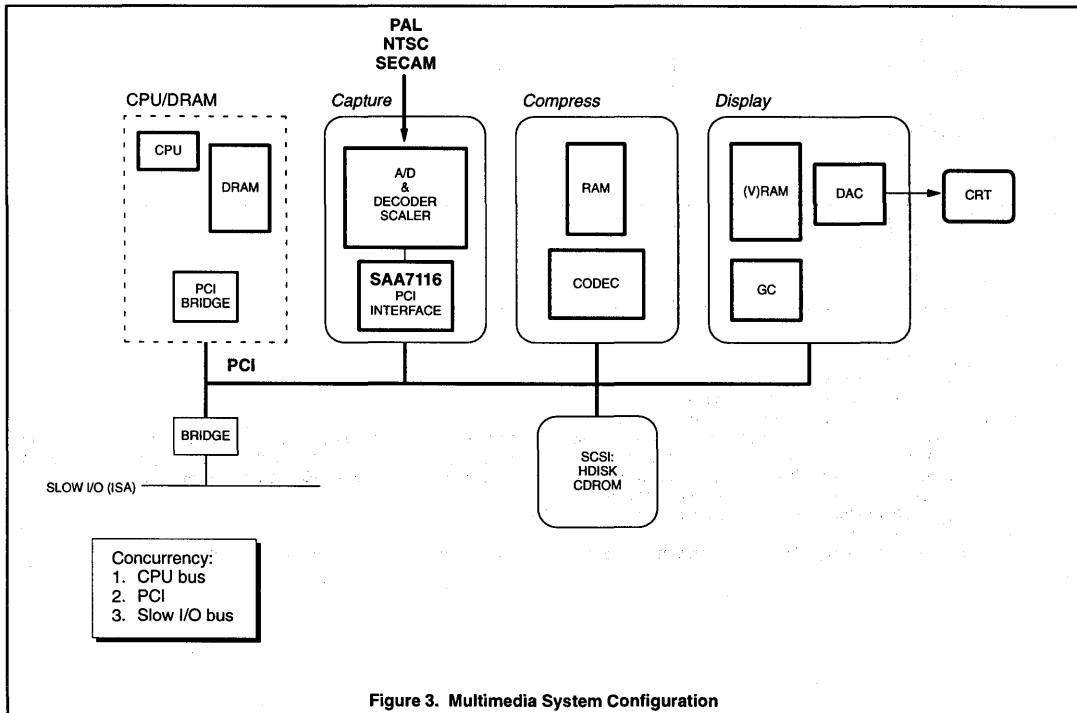

Figure 3. Multimedia System Configuration

# Digital video to PCI interface

**SAA7116**

## 2.0 FUNCTIONAL DESCRIPTIONS

### 2.1 Block Diagram

The Block Diagram on page 3-185 illustrates the main design partitions of the SAA7116 IC. Signal polarities are not indicated on any of the diagrams. Please refer to Pin Description.

### 2.2 FIFO

The FIFO block accepts data from the Philips Video Decoder or Scaler in three different pixel formats (YUV16, RGB16, and RGB24), assembles this data into 32-bit words, buffers the data in a FIFO memory, and, in conjunction with the PCI bus master control logic, transmits the image data on to the PCI bus.

The FIFO Input Control Logic samples LNQ and PXQ to determine if the data driven by the Video Decoder or Scaler is valid and should be written into the FIFO.

Active to inactive transitions on HGT and VGT indicate an end of line (EOL) or end of field/frame (EOF) has occurred.

### 2.2.1 Pixel FIFO

The pixel FIFO acts as a buffer between the slow, steady pixel data stream generated by the Video Decoder or Scaler and the fast, "bursty" PCI bus.

### 2.3 Address Generator

The Address Generator provides the DMA address to be driven onto PCI for a bus cycle. There are 6 DMA address registers: 3 even registers and 3 odd registers. Each DMA register has an associated stride register.

### 2.4 Address/Data multiplexer

The Address/Data MUX controls whether address and a bus command or data and byte enables are driven onto the PCI bus. It is controlled by the Master Control Logic.

### 2.5 Master Control Block

The Master Control Block orchestrates the flow of address and data onto the PCI bus during master cycles.

Once a DMA address is generated, the Master Control Logic asserts REQ to the PCI

bus and waits for the assertion of GNT. Once GNT is asserted, the Master Control Block asserts FRAME, and drives the address and bus command onto the PCI bus. On the subsequent clock, the Master Control Logic switches the Address/Data MUX to drive data and byte enables and asserts IRDY. The SAA7116 supports 0 WS burst writes.

### 2.6 Master Latency Timer

The Master Latency Timer is an 8 bit counter. When the Master Control Logic asserts FRAME, the Master Latency Timer/Counter is enabled. If FRAME is de-asserted before the counter expires, the Master Latency Timer is meaningless. If the counter expires before the de-assertion of FRAME, or other STOP condition is asserted, and GNT is deasserted, the bus cycle will be terminated.

### 2.7 Slave Logic

The Slave Logic decodes PCI cycles to memory and configuration registers. Some of these local registers are transmitted on the I<sup>2</sup>C interface to the I<sup>2</sup>C-controlled ICs of the video capture IC set.

# Digital video to PCI interface

# SAA7116

## 2.8 Programmable Registers of SAA7116

### REGISTER TYPES

- RO x** Read-only with value x. Writing to this type of register has no effect.
- RW** Read/write. All bits are initialized to 0 upon hardware reset.
- RS** Read/set. This register type may be read, or be set to 1 by writing a 1 into the corresponding bit location. Writing 0 has no effect. Events internal to SAA7116 can cause this register type to be reset to 0. All bits are initialized to 0 upon hardware reset.

**RR** Read/reset. This register type may be read, or be reset to 0 by writing a 1 into the corresponding bit location. Writing 0 has no effect. Events internal to the SAA7116 can cause this register type to be set to 1. All bits are initialized to 0 upon hardware reset.

### NOTES:

1. All bit positions not listed in the following register description are of type RO 0b.
2. Registers marked with an \* are actively used while capture is enabled, and should only be changed when the SAA7116 capture is inactive.
  - o\* registers can be changed during even field capture.
  - e\* registers can be changed during odd field capture.
3. Register types marked with \*\* are used during I<sup>2</sup>C cycles, and should only be changed when the I<sup>2</sup>C controller is inactive.

### 2.8.1 PCI Configuration Registers

OFFSET	BITS	TYPE	REGISTER	WORD 3				WORD 2				WORD 1				WORD 0															
				31	24	23	16	15	8	7	0	31	24	23	16	15	8	7	0	31	24	23	16	15	8	7	0	31	24	23	16
00h	31:16	RO	Device ID													1223h															
	15:0	RO	Vendor ID													8086h															
04h	29	RR	Master Abort Generated A value of 1 indicates that a master abort was generated while attempting to perform a DMA operation. Writing a 1 will reset this bit.																												
	28	RR	Target Abort Detected A value of 1 indicates that a target abort was detected while performing a DMA operation. Writing a 1 will reset this bit.																												
	26:25	RO	DEVSEL# Timing SAA7116 performs "Medium" speed device select.													01b															
	2	RW	Master Enable 1 = enable SAA7116 master cycles. 0 = disable SAA7116 master cycles.																												
	1	RW	Memory Enable 1 = enable SAA7116 slave decode to memory mapped registers. This configuration is required to access the SAA7116 memory registers. 0 = disable SAA7116 memory registers.																												
08h	31:8	RO	Class Code The code for "Multimedia Video Device" is returned in this register.													040000h															
	7:0	RO	Revision ID													00h															
0Ch	15:8	RW	Latency Timer Specifies the number of PCI clocks that must elapse before a de-assertion of the GNT# pin will cause the SAA7116 master to give up ownership of the PCI bus.																												
10h	31:12	RW	Memory Base Address																												
	11:0	RO	Specifies the base address of the SAA7116 memory-mapped registers. SAA7116 claims a 4K address space by making bits 11:0 of this register RO 000h.													000h															
3Ch	15:11	RO	Interrupt Pin													00000b															
	10:8	RO	This register specifies the PCI interrupt line that the SAA7116 is connected to. Values of 1, 2, 3, and 4, correspond to INTA#, INTB#, INTC#, and INTD#, respectively. Bits 10:8 of this register echo the status of the 3 pins int_pin[2:0], which should be wired appropriately in hardware.																												
	7:0	RW	Interrupt Line This is an 8-bit register, used by BIOS software to indicate which IRQ line (for PC architectures) SAA7116 is mapped to.																												

# Digital video to PCI interface

# SAA7116

## 2.8.2 Memory Registers

**NOTE:** Memory registers are accessed through PCI control base memory address register 10h with appropriate offset shown below.

OFFSET	BITS	TYPE	REGISTER	REGISTER BIT FIELD							
				WORD 3	WORD 2	WORD 1	WORD 0				
				31	24	23	16	15	8	7	0
00h	31:1	e*RW	DMA 1 (Even)								
	0	RO 0b	Base address for even field DMA channel 1. This value is specified as a standard 32-bit byte address. The LSB is forced to 0.								
04h	31:2	e*RW	DMA 2 (Even)								
	1:0	RO 00b	Base address for even field DMA channel 2.								
08h	31:2	e*RW	DMA 3 (Even)								
	1:0	RO 00b	Base address for even field DMA channel 3.								
0Ch	31:1	o*RW	DMA 1 (Odd)								
	0	RO 0b	Base address for odd field DMA channel 1.								
10h	31:2	o*RW	DMA 2 (Odd)								
	1:0	RO 00b	Base address for odd field DMA channel 2.								
14h	31:2	o*RW	DMA 3 (Odd)								
	1:0	RO 00b	Base address for odd field DMA channel 3.								
18h	15:2	e*RW	Stride 1 (Even)								
	1:0	RO 00b	Address stride for even field DMA channel 1. Bits 15:0 specify a byte value to be added to the address of the last pixel of a scan line, to generate the address of the next consecutive scan line. The two LSBs are forced to 0.								
1Ch	15:2	e*RW	Stride 2 (Even)								
	1:0	RO 00b	Address stride for even field DMA channel 2.								
20h	15:2	e*RW	Stride 3 (Even)								
	1:0	RO 00b	Address stride for even field DMA channel 3.								
24h	15:2	o*RW	Stride 1 (Odd)								
	1:0	RO 00b	Address stride for odd field DMA channel 1								
28h	15:2	o*RW	Stride 2 (Odd)								
	1:0	RO 00b	Address stride for odd field DMA channel 2.								
2Ch	15:2	o*RW	Stride 3 (Odd)								
	1:0	RO 00b	Address stride for odd field DMA channel 3.								
30h	31:8	*RW	Route (Even)								
			Pixel router mode for even fields. The following values are defined, based on pixel format:								
			<b>Pixel Format</b>	<b>Value</b>							
			RGB 24 packed	393939h							
			RGB 16 packed	eeeeeeh							
			YUV 16 packed	eeeeeeh							
			YUV 16 planar	aaaaffh							
			YUV 9 planar	aaaaffh							
			YUV 12 planar	aaaaffh							
	7:0	*RW	Mode (Even)								
			Pixel format for even fields. The following formats are defined:								
			<b>Pixel Format</b>	<b>Value</b>							
			RGB 24 packed	00h							
			RGB 16 packed	01h							
			YUV 16 packed	41h							
			YUV 16 planar	C1h							
			YUV 12 planar	C2h							
			YUV 9 planar	C3h							

# Digital video to PCI interface

# SAA7116

OFFSET	BITS	TYPE	REGISTER	WORD 3				WORD 2				WORD 1				WORD 0			
				31	30	29	24	23	22	21	16	15	14	13	8	7	6	5	0
34h	31:8	*RW	Route (Odd) See description for even field route.																
	7:0	*RW	Mode (Odd) See description for even field mode.																
38h	22:16	*RW	FIFO Trigger Planar Mode Specifies the number of Dwords that must collect in FIFO 1 (the "Y" FIFO) before a PCI data transfer is triggered, in planar pixel modes.																
	6:0	*RW	FIFO Trigger Packed Mode Specifies one-half the number of Dwords that must collect in the internal FIFOs before a PCI data transfer is triggered, in packed pixel modes.																
3Ch	9:8	*RW	Reserved Leave alone or set to 0,0.																
	2	*RW	Field Toggle When enabled, field toggle mode causes the SAA7116 to emulate interlaced video, when presented with a non-interlaced video signal. This is done by internally toggling the odd/even field signal and overwriting the detection from a non-interlaced or distorted input signal (e.g., VCR-feature modes). 1 = enable field toggle mode 0 = disable field toggle mode																
	1	*RW	Reserved Set to 1.																
	0	*RW	Reserved Set to 1.																
40h	15	*RW	Range Enable Specifies whether address range checking is enabled. Note that this feature is only intended to be disabled for test purposes. DMA end (even and odd) must also be set, for this feature to function. 1 = enable address range checking 0 = disable address range checking																
	14	*RW	Corrupt Disable Specifies how the FIFO overflow condition is handled. 1 = ignore FIFO overflow. This setting is intended for test purposes ONLY. 0 = drop remainder of current field if FIFO overflows.																
	11	RR	Address Error (Odd) Specifies whether an internal DMA address exceeding DMA End (Odd) was generated. 1 = odd field address error detected. The remainder of the odd field was dropped. 0 = no address errors detected This bit must be reset once triggered.																
	10	RR	Address Error (Even) Specifies whether an internal DMA address exceeding DMA End (Even) was generated. 1 = even field address error detected. The remainder of the even field was dropped. 0 = no address errors detected This bit must be reset once triggered.																
	9	RR	Field Corrupt (Odd) 1 = FIFO overflow detected during odd field capture. The remainder of the odd field was dropped. 0 = no FIFO overflows detected. This bit must be reset once triggered																

# Digital video to PCI interface

# SAA7116

OFFSET	BITS	TYPE	REGISTER	REGISTER BIT FIELD			
				WORD 3	WORD 2	WORD 1	WORD 0
				31 . . . 24	23 . . . 16	15 . . . 8	7 . . . 0
40h (cont.)	8	RR	Field Corrupt (Even) 1 = FIFO overflow detected during even field capture. The remainder of the even field was dropped. 0 = no FIFO overflows detected. This bit must be reset once triggered.				
	7	*RW	FIFO Enable Writing a 0 to this location puts the internal FIFO and I <sup>2</sup> C logic into a reset state. Writing a 1 enables the FIFO and I <sup>2</sup> C logic.				
	6	*RW	VRSTN# This bit is tied directly to the VRSTN# output pin. Writing a 0 puts the external decoder/scaler/clock generator into a reset state. Writing a 1 brings them out of reset.				
	5	RR	Field Done (Odd) 1 = end of captured odd field detected. This bit is set once the final pixel of the odd field has been transferred on the PCI bus. 0 = end of odd field not detected yet.				
	4	RR	Field Done (Even) 1 = end of captured even field detected. This bit is set once the final pixel of the even field has been transferred on the PCI bus. 0 = end of even field not detected yet.				
	3	RS	Single Field Capture (Odd) Setting this bit causes the SAA7116 to capture a single odd field. This bit is reset once the field capture operation has been completed.				
	2	RS	Single Field Capture (Even) Setting this bit causes the SAA7116 to capture a single even field. This bit is reset once the field capture operation has been completed.				
	1	RW	Capture (Odd) Setting this bit causes the SAA7116 to continuously capture odd fields. Clearing this bit causes the SAA7116 to stop capturing AFTER the current field capture has been completed.				
	0	RW	Capture (Even) Setting this bit causes the SAA7116 to continuously capture even fields. Clearing this bit causes the SAA7116 to stop capturing AFTER the current field capture has been completed.				
44	7:0	*RW	Retry Wait Counter Specifies the number of clocks that the SAA7116 PCI master will wait after receiving a disconnect from a slave, before retrying a transaction to the current destination.				

## Digital video to PCI interface

## SAA7116

OFFSET	BITS	TYPE	REGISTER	WORD 3		WORD 2		WORD 1		WORD 0	
				31	24	23	16	15	8	7	0
48h	10	RW	Interrupt mask, start of field 1 = enable interrupt for start of field. This interrupt is triggered for every incoming field, regardless of whether it is being captured. 0 = disable this interrupt								
	9	RW	Interrupt mask, end of odd field 1 = enable interrupt for end of captured odd field. 0 = disable this interrupt.								
	8	RW	Interrupt mask, end of even field 1 = enable interrupt for end of captured even field. 0 = disable this interrupt.								
	2	RR	Interrupt status, start of field This bit is set when the start of field interrupt has been triggered.								
	1	RR	Interrupt status, end of odd field This bit is set when the end of captured odd field interrupt has been triggered.								
	0	RR	Interrupt status, end of even field This bit is set when the end of captured even field interrupt has been triggered.								
4Ch	31:0	*RW	Field Mask (Even) For continuous capture mode only, this 32-bit pattern specifies a sequence of even fields to either capture or mask. The LSB is the first field in the sequence. A bit value of 1 corresponds to a field to capture, and a value of 0 to a field to mask. See the Mask Length (Odd) description for an example.								
50h	31:0	*RW	Field Mask (Odd) For continuous capture mode only this 32-bit pattern specifies a sequence of odd fields to either capture or mask. The LSB is the first field in the sequence. A bit value of 1 corresponds to a field to capture, and a value of 0 to a field to mask. See the Mask Length (Odd) description for an example.								
54h	20:16	*RW	Mask Length (Odd) Specifies the length (minus 1) of the odd field mask. For example, a mask value of 0000001h and a mask length value of 1h causes every other field to be captured. A mask of 00000001h and a mask length of 0h causes every field to be captured.								
	4:0	*RW	Mask Length (Even) Specifies the length (minus 1) of the even field mask.								
58h	22:16	*RW	FIFO Almost Empty Pointer Specifies the number of Dwords needed in FIFO 1 to trigger an almost empty condition. This condition is used to terminate PCI burst transfers. If it is set too low, FIFO underflows could result. A good value is 5h.								
	6:0	*RW	FIFO Almost Full Pointer Specifies the number of Dwords needed in FIFO 1 to trigger an almost full condition. This condition is used to flag FIFO overflows and to terminate capture of the current field. If it is set too high, overflows may not be detected in time, and unpredictable behavior may result. To utilize the entire FIFO, a good setting is 7Ch. This value may be decreased to simulate a smaller FIFO.								
5Ch	31:24	**RW	I <sup>2</sup> C Phase 4 I <sup>2</sup> C clock cycles are broken into four phases by the SAA7116 I <sup>2</sup> C master. This register specifies the duration of the fourth phase in number of VCLK cycles (typically 80 ns).								
	23:16	**RW	I <sup>2</sup> C Phase 3 The duration of the 3rd I <sup>2</sup> C clock phase in VCLK cycles.								
	15:8	**RW	I <sup>2</sup> C Phase 2 The duration of the 2nd I <sup>2</sup> C clock phase in VCLK cycles.								
	7:0	**RW	I <sup>2</sup> C Phase 1 The duration of the first I <sup>2</sup> C clock phase in VCLK cycles.								



## Digital video to PCI interface

SAA7116

OFFSET	BITS	TYPE	REGISTER	REGISTER BIT POSITIONS			
				WORD 3	WORD 2	WORD 1	WORD 0
				31 . . . . 24	23 . . . . 16	15 . . . . 8	7 . . . . 0
60h	31:24	RO	I <sup>2</sup> C Read Data 8 bits of read data returned by an I <sup>2</sup> C read operation. <b>Warning:</b> do not read this register while an I <sup>2</sup> C read operation is in progress.				
	23:16	**RW	I <sup>2</sup> C Auto Address The I <sup>2</sup> C slave address to be used for all auto-update cycles.				
	11	RO	I <sup>2</sup> C SCL Input The state of the I <sup>2</sup> C SCL signal external to the SAA7116 may be read on this bit.				
	10	RO	I <sup>2</sup> C SDA Input The state of the I <sup>2</sup> C SDA signal external to the SAA7116 may be read on this bit.				
	9	RR	I <sup>2</sup> C Direct Abort This bit indicates whether the last I <sup>2</sup> C direct cycle was successful. 0 = success 1 = cycle aborted This bit must be reset once triggered.				
	8	RR	I <sup>2</sup> C Auto Abort This bit indicates whether the last I <sup>2</sup> C auto update cycle was successful. 0 = success 1 = cycle aborted This bit must be reset after being set.				
	3	RW	I <sup>2</sup> C SCL Output When in I <sup>2</sup> C bypass mode, the value of this bit is driven out onto the SCL pin.				
	2	RW	I <sup>2</sup> C SDA Output When in I <sup>2</sup> C bypass mode, the value of this bit is driven out onto the SDA pin.				
	1	RW	I <sup>2</sup> C Bypass 1 = enable I <sup>2</sup> C bypass mode. When in this mode, the SCL and SDA pins are driven by the I <sup>2</sup> C SCL Output and I <sup>2</sup> C SDA Output bits, respectively. 0 = disable I <sup>2</sup> C bypass mode. This is the normal mode of operation. In this mode, the SCL and SDA pins are driven by the SAA7116 I <sup>2</sup> C bus master logic. This configuration must be selected for I <sup>2</sup> C direct and auto update cycles to function.				
	0	RW	I <sup>2</sup> C Auto Enable This bit enables the I <sup>2</sup> C automatic update mode. In this mode, data stored in the SAA7116 "Auto Data" registers is automatically copied through the I <sup>2</sup> C interface to the control register of video capture ICs at the beginning of each field. The SAA7116 stores 2 banks (1 per field) of 8 registers each, allowing up to 8 external I <sup>2</sup> C registers to have separate values for even and odd fields. This feature is intended to allow each field to have its own scale factors and color space. 1 = enable I <sup>2</sup> C auto update mode. 0 = disable I <sup>2</sup> C auto update mode.				
64h	24	RS	I <sup>2</sup> C New Cycle When this bit has been set, the SAA7116 will execute a direct I <sup>2</sup> C cycle, using the I <sup>2</sup> C Direct Address, Sub-address (for write cycles), and Write data (for write cycles) fields. This bit is automatically cleared when the cycle has been completed. The I <sup>2</sup> C Direct Abort bit should then be checked for successful completion.				
	23:16	**RW	I <sup>2</sup> C Direct Address The I <sup>2</sup> C slave address used for I <sup>2</sup> C direct cycles. The upper 7 bits of this field specify a device address, while the LSB specifies whether a read or write operation is to be performed on the I <sup>2</sup> C bus. A value of 1 corresponds to a read and a 0 to a write.				
	15:8	**RW	I <sup>2</sup> C Direct Sub-address The 8-bit sub-address to be used for I <sup>2</sup> C direct WRITE cycles. This field is ignored for reads.				
	7:0	**RW	I <sup>2</sup> C Direct Write Data 8 bits of write data to be used for I <sup>2</sup> C direct WRITE cycles. This field is ignored for I <sup>2</sup> C read cycles.				

# Digital video to PCI interface

# SAA7116

OFFSET	BITS	TYPE	REGISTER	WORD 3		WORD 2		WORD 1		WORD 0	
				31	24	23	16	15	8	7	0
68h	31:24	**RW	I <sup>2</sup> C Auto Sub-address 1 (Even) Sub-address for auto update cycle 1, to be written during the EVEN field. Since the scaling registers of SAA7196, for example, are double buffered, the results of this cycle won't be seen until the ODD field.								
	23:16	**RW	I <sup>2</sup> C Auto Data 1 (Even) Data for auto update cycle 1.								
	15:8	**RW	I <sup>2</sup> C Auto Sub-address 0 (Even) Sub-address for auto update cycle 0.								
	7:0	**RW	I <sup>2</sup> C Auto Data 0 (Even) Data for auto update cycle 0.								
6Ch	31:24	**RW	I <sup>2</sup> C Auto Sub-address 3 (Even)								
	23:16	**RW	I <sup>2</sup> C Auto Data 3 (Even)								
	15:8	**RW	I <sup>2</sup> C Auto Sub-address 2 (Even)								
	7:0	**RW	I <sup>2</sup> C Auto Data 2 (Even)								
70h	31:24	**RW	I <sup>2</sup> C Auto Sub-address 5 (Even)								
	23:16	**RW	I <sup>2</sup> C Auto Data 5 (Even)								
	15:8	**RW	I <sup>2</sup> C Auto Sub-address 4 (Even)								
	7:0	**RW	I <sup>2</sup> C Auto Data 4 (Even)								
74h	31:24	**RW	I <sup>2</sup> C Auto Sub-address 7 (Even)								
	23:16	**RW	I <sup>2</sup> C Auto Data 7 (Even)								
	15:8	**RW	I <sup>2</sup> C Auto Sub-address 6 (Even)								
	7:0	**RW	I <sup>2</sup> C Auto Data 6 (Even)								
78h	31:24	**RW	I <sup>2</sup> C Auto Sub-address 1 (Odd) Sub-address for auto update cycle 1, to be written during the ODD field. Since the scaling registers of SAA7196, for example, are double buffered, the results of this cycle won't be seen until the EVEN field.								
	23:16	**RW	I <sup>2</sup> C Auto Data 1 (Odd) Data for auto update cycle 1.								
	15:8	**RW	I <sup>2</sup> C Auto Sub-address 0 (Odd) Sub-address for auto update cycle 0.								
	7:0	**RW	I <sup>2</sup> C Auto Data 0 (Odd) Data for auto update cycle 0.								
7Ch	31:24	**RW	I <sup>2</sup> C Auto Sub-address 3 (Odd)								
	23:16	**RW	I <sup>2</sup> C Auto Data 3 (Odd)								
	15:8	**RW	I <sup>2</sup> C Auto Sub-address 2 (Odd)								
	7:0	**RW	I <sup>2</sup> C Auto Data 2 (Odd)								
80h	31:24	**RW	I <sup>2</sup> C Auto Sub-address 5 (Odd)								
	23:16	**RW	I <sup>2</sup> C Auto Data 5 (Odd)								
	15:8	**RW	I <sup>2</sup> C Auto Sub-address 4 (Odd)								
	7:0	**RW	I <sup>2</sup> C Auto Data 4 (Odd)								
84h	31:24	**RW	I <sup>2</sup> C Auto Sub-address 7 (Odd)								
	23:16	**RW	I <sup>2</sup> C Auto Data 7 (Odd)								
	15:8	**RW	I <sup>2</sup> C Auto Sub-address 6 (Odd)								
	7:0	**RW	I <sup>2</sup> C Auto Data 6 (Odd)								

Digital video to PCI interface

SAA7116

OFFSET	BITS	TYPE	REGISTER	WORD 3				WORD 2				WORD 1				WORD 0											
				31	24	23	16	15	8	7	0	31	24	23	16	15	8	7	0	31	24	23	16	15	8	7	0
88h	23:16	**RW	I <sup>2</sup> C Register Enable (Odd) This field specifies which of the 8 auto update sub-address/data registers for ODD field auto updates is valid. The LSB corresponds to subaddress/data 0, and the MSB to subaddress/data 7. A value of 1 in a bit position enables the corresponding subaddress/data pair.																								
	7:0	**RW	I <sup>2</sup> C Register Enable (Even) This field specifies which of the 8 auto update sub-address/data registers for EVEN field auto updates is valid. The LSB corresponds to subaddress/data 0, and the MSB to subaddress/data 7. A value of 1 in a bit position enables the corresponding subaddress/data pair.																								
8Ch	23:2	e*RW	DMA End (Even)																								
	1:0	RO 00b	This register sets the upper bound (inclusive) of the address window that the SAA7116 master may write to during even field DMA. The Range Enable bit must be set for this feature to function. Although only 24 bits are defined in this register, software should write a full 32-bit byte address, to maintain compatibility with possible future implementations of the SAA7116. The current SAA7116 design uses the 8 MSBs of the 3 DMA even channel address registers (depending on which channel is active) as the 8 MSBs of DMA End.																								
90h	23:2	o*RW	DMA End (Odd)																								
	1:0	RO 00b	This register sets the upper bound (inclusive) of the address window that the SAA7116 master may write to during odd field DMA. The Range Enable bit must be set for this feature to function. Although only 24 bits are defined in this register, software should write a full 32-bit byte address, to maintain compatibility with possible future implementations of the SAA7116. The current SAA7116 design uses the 8 MSBs of the 3 DMA odd channel address registers (depending on which channel is active) as the 8 MSBs of DMA End.																								

## Digital video to PCI interface

SAA7116

**LIMITING VALUES**

In accordance with the Absolute Maximum Rating system (IEC 134).

SYMBOL	PARAMETER	MIN.	MAX.	UNIT
V <sub>DD</sub>	Supply voltage	-0.5	6.5	V
V <sub>I</sub>	DC input voltage on all pins	-0.5	V <sub>DD</sub>	V
I <sub>DD</sub>	Supply current	-	200	mA
P <sub>tot</sub>	Total power dissipation	0	1	W
T <sub>stg</sub>	Storage temperature range	-65	150	°C
T <sub>amb</sub>	Operating ambient temperature range	0	70	°C
V <sub>ESD</sub>	Electrostatic handling <sup>1</sup> for all pins	-	±2000	V

**NOTES:**

1. Equivalent to discharging a 150pF capacitor through a 1.5kΩ series resistor.

**DC CHARACTERISTICS**V<sub>DD</sub> = 4.75 to 5.25V; T<sub>amb</sub> = 0 to 70°C, unless otherwise specified.

SYMBOL	PARAMETER	CONDITION	MIN.	MAX.	UNIT
V <sub>DD</sub>	Supply voltage		4.75	5.25	V
I <sub>P</sub>	Total supply current	Inputs LOW; no output loads		200	mA
V <sub>IH</sub>	Input HIGH voltage		2.0	V <sub>CC</sub> +0.5	V
V <sub>IL</sub>	Input LOW voltage		-0.5	0.8	V
I <sub>IH</sub>	Input HIGH leakage current	V <sub>IN</sub> = 2.7 V Note 1		70	μA
I <sub>IL</sub>	Input LOW leakage current	V <sub>IN</sub> = 0.5 V Note 1		-70	μA
V <sub>OH</sub>	Output HIGH voltage	I <sub>OUT</sub> = -2 mA	2.4		V
V <sub>OL</sub>	Output LOW voltage	I <sub>OUT</sub> = 3 mA, 6 mA Note 2		0.55	V
C <sub>IN</sub>	Input pin capacitance			10	pF
C <sub>CLK</sub>	CLK pin capacitance		5	12	pF
C <sub>IDSEL</sub>	IDSEL pin capacitance			8	pF
L <sub>pin</sub>	Pin inductance			20	nH
<b>3-State Outputs</b>					
I <sub>O off</sub>	High-impedance output current		-	±70	μA
C <sub>I</sub>	High-impedance output capacitance		-	8	pF
<b>I<sup>2</sup>C-bus, SDA and SCL</b>					
V <sub>IL</sub>	Input voltage LOW		-0.5	1.5	V
V <sub>IH</sub>	Input voltage HIGH		3	V <sub>DD</sub> +0.5	V
I <sub>IN</sub>	Input current		-	±10	μA
I <sub>ACK</sub>	Output current on SDA pin	Acknowledge	3	-	mA
V <sub>OL</sub>	Output voltage at Acknowledge	I <sub>SDA</sub> = 3 mA	-	0.4	V

**NOTES:**

1. Input leakage currents include Hi-Z output leakage for all bi-directional buffers with 3-State outputs.
2. Signals without pullup resistors must have 3 mA low output current. Signals requiring pull up must have 6 mA.

# Digital video to PCI interface

# SAA7116

## AC CHARACTERISTICS

V<sub>DD</sub> = 4.75 to 5.25V; T<sub>amb</sub> = 0 to 70°C, unless otherwise specified.

SYMBOL	PARAMETER	CONDITIONS <sup>1</sup>	MIN.	MAX.	UNIT
t <sub>CYC</sub>	CLK cycle time		30	∞	ns
t <sub>HIGH</sub>	CLK HIGH time		12		ns
t <sub>LOW</sub>	CLK LOW time		12		ns
–	CLK slew rate		1	4	V/ns
t <sub>VAL</sub>	CLK to signal valid delay – bussed signals		2	11	ns
t <sub>VAL (ptp)</sub>	CLK to signal valid delay – point-to-point		2	12	ns
t <sub>ON</sub>	Float to active delay		2	11	ns
t <sub>OFF</sub>	Active to float delay			28	ns
t <sub>SU</sub>	Input set up time to CLK – bused signals		7		ns
t <sub>SU (ptp)</sub>	Input set up time to CLK – point-to-point		10		ns
t <sub>H</sub>	Input hold time from CLK		0		ns
t <sub>RST</sub>	Reset active time after power stable		1		ms
t <sub>RST-CLK</sub>	Reset active time after CLK stable		100		µs
t <sub>RST-OFF</sub>	Reset active to output float delay			40	ns
I <sub>OH(AC)</sub>	Switching current HIGH	0 < V <sub>OUT</sub> ≤ 1.4	–44		mA
		1.4 < V <sub>OUT</sub> < 2.4	$\frac{-44 + (V_{OUT} - 1.4)}{0.024}$	11.9*(V <sub>OUT</sub> –5.25) *(V <sub>OUT</sub> +2.45)	mA
		(Test point) V <sub>OUT</sub> = 3.1		–142	mA
I <sub>OL(AC)</sub>	Switching current LOW	V <sub>OUT</sub> ≥ 2.2	95		mA
		2.2 > V <sub>OUT</sub> > 0.55	$\frac{V_{OUT}}{0.023}$	78.5*V <sub>OUT</sub> *(4.4–V <sub>OUT</sub> )	mA
		(Test point) V <sub>OUT</sub> = 0.71		206	mA
I <sub>CL</sub>	Low clamp current	–5 < V <sub>IN</sub> ≤ –1	$\frac{-25 + (V_{IN} + 1)}{0.015}$		mA
t <sub>R</sub>	Unloaded output rise time	0.4V to 2.4V	1	5	V/ns
t <sub>F</sub>	Unloaded output fall time	2.4V to 0.4V	1	5	V/ns

**NOTE:**

1. Timing measurement conditions meets the PCI Local Bus specifications.

# Digital multistandard colour decoder with SCART interface (DMSD2-SCART)

## SAA7151B

### 1. FEATURES

- 8-bit performance on chip for luminance and chrominance signal processing for PAL, NTSC and SECAM standards
- Separate 8-bit luminance and 8-bit chrominance input signals from Y/C, CVBS, S-Video (S-VHS or Hi8) sources
- SCART signal insertion by means of RGB/YUV conversion; fast switch handling
- Horizontal and vertical sync detection for all standards
- Real time control output RTCO
- Fast sync recovery of vertical blanking for VCR signals (bottom flutter compensation)
- Controls via the I<sup>2</sup>C-bus
- User programmable aperture correction (horizontal peaking)
- Cross-colour reduction by chrominance comb-filtering (NTSC) or by special cross-colour cancellation (SECAM)
- 8-bit quantization of output signals in 4:1:1 or 4:2:2 formats
- 720 active samples per line
- The YUV bus supports a data rate of 13.5 MHz (CCIR 601).
  - (864 x f<sub>H</sub>) for 50 Hz
  - (858 x f<sub>H</sub>) for 60 Hz
- Compatible with memory-based features (line-locked clock)
- One 24.576 MHz crystal oscillator for all standards

### 2. GENERAL DESCRIPTION

The SAA7151B is a digital multistandard colour-decoder having two 8-bit input channels, one for CVBS or Y, the other for chrominance or time-multiplexed colour-difference signals.

### 3. QUICK REFERENCE DATA

SYMBOL	PARAMETER	MIN.	TYP.	MAX.	UNIT
V <sub>DD</sub>	supply voltage (pins 5, 18, 28, 37 and 52)	4.5	5	5.5	V
I <sub>DD</sub>	total supply current (pins 5, 18, 28, 37 and 52)	-	100	250	mA
V <sub>I</sub>	input levels	TTL-compatible			
V <sub>O</sub>	output levels	TTL-compatible			
T <sub>amb</sub>	operating ambient temperature	0	-	70	°C

### 4. ORDERING INFORMATION

EXTENDED TYPE NUMBER	PACKAGE			
	PINS	PIN POSITION	MATERIAL	CODE
SAA7151B	68	mini-pack PLCC	plastic	SOT188

Digital multistandard colour decoder  
with SCART interface (DMSD2-SCART)

SAA7151B

5. BLOCK DIAGRAM

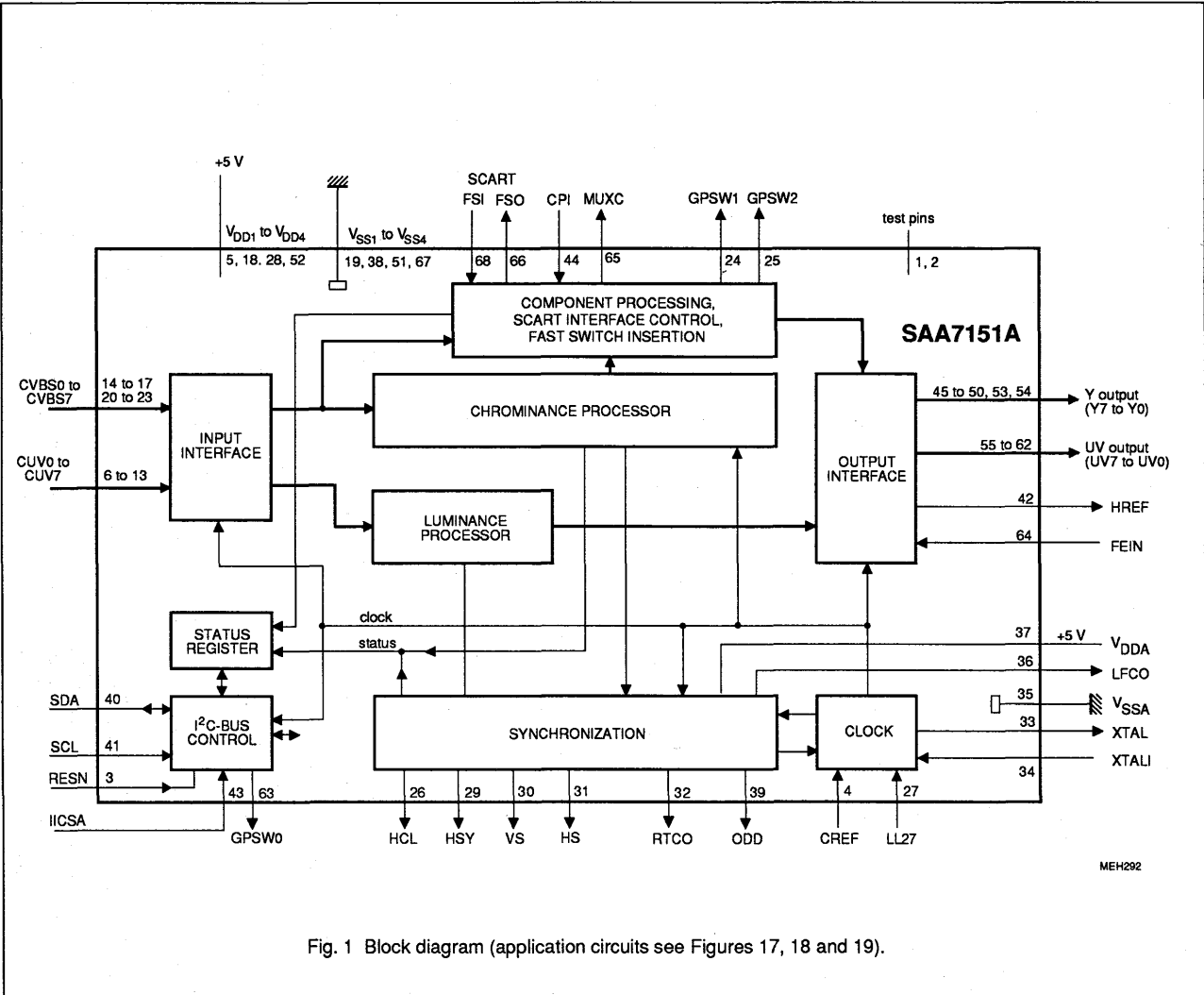

Fig. 1 Block diagram (application circuits see Figures 17, 18 and 19).

MEH292

# Digital multistandard colour decoder with SCART interface (DMSD2-SCART)

SAA7151B

## 6. PINNING

SYMBOL	PIN	DESCRIPTION
SP	1	connected to ground (shift pin for testing)
AP	2	connected to ground (action pin for testing)
RESN	3	reset, active-LOW
CREF	4	clock reference, sync from external to ensure in-phase signals on the Y-, CUV- and YUV-bus
V <sub>DD1</sub>	5	+5 V supply input 1
CUV0	6	chrominance input data bits CUV7 to CUV0 (digitized chrominance signals in two's complement format from a S-Video source (S-VHS, Hi8) or time-multiplexed colour-difference signals from a YUV(RGB) source or both in combination)
CUV1	7	
CUV2	8	
CUV3	9	
CUV4	10	
CUV5	11	
CUV6	12	
CUV7	13	
CVBS0	14	CVBS lower input data bits CVBS3 to CVBS0 (CVBS with luminance, chrominance and all sync information in two's complement format)
CVBS1	15	
CVBS2	16	
CVBS3	17	
V <sub>DD2</sub>	18	+5 V supply input 2
V <sub>SS1</sub>	19	ground 1 (0 V)
CVBS4	20	CVBS upper input data bits CVBS7 to CVBS4 (CVBS with luminance, chrominance and all sync information in two's complement format)
CVBS5	21	
CVBS6	22	
CVBS7	23	
GPSW1	24	status bit output FSST0 or port 1 output for general purpose (programmable by subaddress 0C)
GPSW2	25	status bit output FSST1 or port 2 output for general purpose (programmable by subaddress 0C)
HCL	26	black level clamp pulse output (begin and stop programmable), e.g. for TDA8708A (ADC)
LL27	27	line-locked system clock input signal (27 MHz)
V <sub>DD3</sub>	28	+5 V supply input 3
HSY	29	hor. sync pulse reference output (begin and stop programmable), e.g. for gain adj. TDA8708A (ADC)
VS	30	vertical sync output signal (Fig.10)
HS	31	horizontal sync output signal (Fig.14; start point programmable)
RTCO	32	real time control output; serial increments of HPLL and FSCPLL and status PAL or SECAM sequence (Fig.9)
XTAL	33	24.576 MHz clock output (open-circuit for use with external oscillator)
XTALI	34	24.576 MHz connection for crystal or external oscillator (TTL compatible squarewave)



# Digital multistandard colour decoder with SCART interface (DMSD2-SCART)

SAA7151B

SYMBOL	PIN	DESCRIPTION
V <sub>SSA</sub>	35	analog ground
LFCO	36	line frequency control output signal, multiple of horizontal frequency (nominal 6.75 MHz)
V <sub>DDA</sub>	37	+5 V supply input for analog part
V <sub>SS2</sub>	38	ground 2 (0 V)
ODD	39	odd/even field identification output (odd = HIGH)
SDA	40	I <sup>2</sup> C-bus data line
SCL	41	I <sup>2</sup> C-bus clock line
HREF	42	horizontal reference for YUV data outputs (for active line 720Y samples long)
IICSA	43	set module address input of I <sup>2</sup> C-bus (LOW = 1000 101X; HIGH = 1000 111X)
CPI	44	clamping pulse input (digital clamping of external UV signals)
Y7	45	Y signal output bits Y7 to Y2 (luminance), part of the digital YUV-bus
Y6	46	
Y5	47	
Y4	48	
Y3	49	
Y2	50	
V <sub>SS3</sub>	51	ground 3 (0 V)
V <sub>DD4</sub>	52	+5 V supply input 4
Y1	53	Y signal output bits Y1 to Y0 (luminance), part of the digital YUV-bus
Y0	54	
UV7	55	UV signal output bits UV7 to UV0, part of the digital YUV-bus
UV6	56	
UV5	57	
UV4	58	
UV3	59	
UV2	60	
UV1	61	
UV0	62	
GPSW0	63	port output for general purpose (programmable by subaddress 0D)
FEIN	64	fast enable input (active-LOW to control fast switching due to YUV data; HIGH = YUV high-Z)
MUXC	65	multiplexer control output; source select signal for external ADC (UV signal multiplexing)
FSO	66	fast switch and sync insertion output; gated FS signal from FSI or sync insertion pulse in full screen RGB mode
V <sub>SS4</sub>	67	ground 4 (0 V)
FSI	68	fast switch input signal fed from SCART/peri-TV connector (indicates fast insertion of RGB signals)

# Digital multistandard colour decoder with SCART interface (DMSD2-SCART)

## SAA7151B

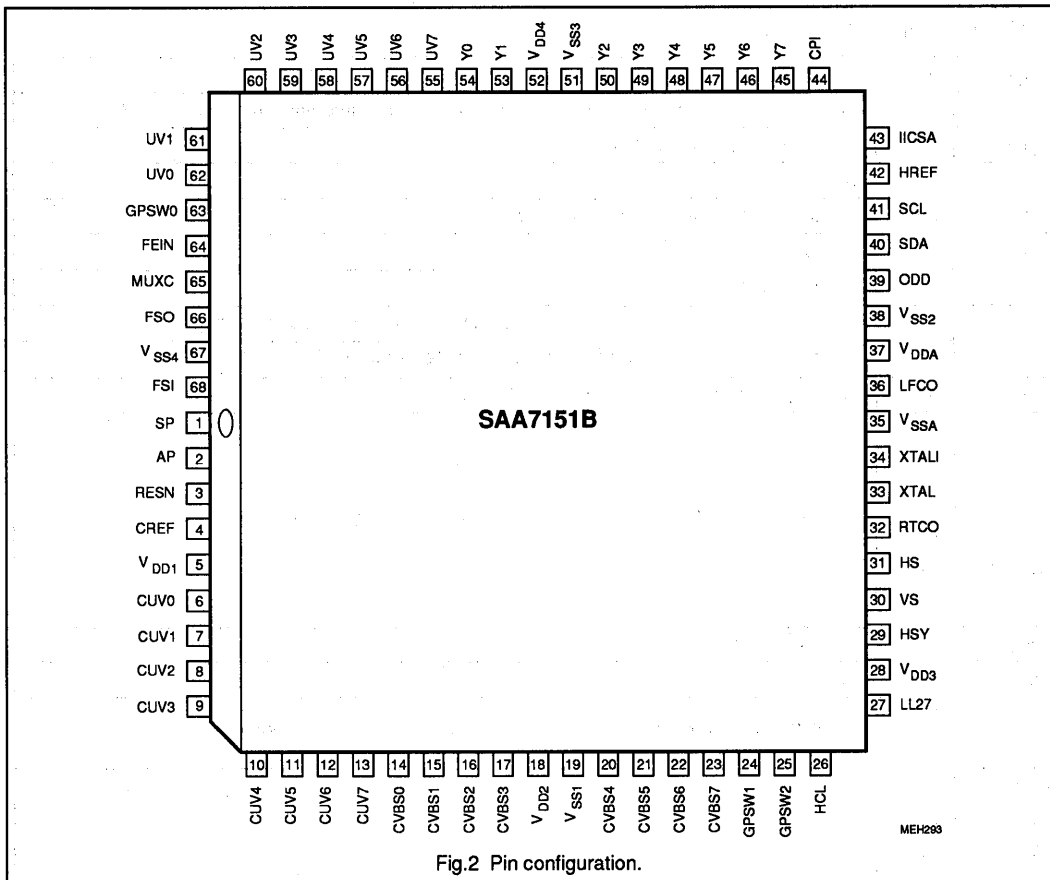

Fig.2 Pin configuration.

### 7. FUNCTIONAL DESCRIPTION

#### System configuration

The SAA7151B system processes digital TV signals with line-locked clock in PAL, SECAM and NTSC standards (CVBS or S-Video) as well as RGB signals coming from a SCART/peri-TV connector. The different source signals are switched, if necessary matrixed and converted (Fig.3 and Table 1).

8-bit CVBS data (digitized composite video) and 8-bit UV data (digitized chrominance and/or time-multiplexed colour-difference signals) are fed to the SAA7151B. The data rate is 27 MHz.

#### Chrominance processing

The 8-bit chrominance input signal (signal "C" out of CVBS or Y/C in Fig.4a) is fed via the input interface to a bandpass filter for eliminating the DC component, then to the quadrature demodulator. Subcarrier signals from the local oscillator (DTO1) with 90 degree phase shift are applied to its multiplier inputs. The frequency depends on set TV standard.

The multipliers operate as a quadrature demodulator for all PAL and NTSC signals; it operates as a frequency down-mixer for SECAM

signals.

The two multiplier output signals are converted to a serial UV data stream and applied to two low-pass filter stages, then to a gain controlled amplifier. A final multiplexed low-pass filter achieves, together with the preceding stages, the required bandwidth performance. The from PAL and NTSC originated signals are applied to a comb-filter. The signals, originated from SECAM, are fed through a cloche filter (0 Hz centre frequency), a phase demodulator and a differentiator to obtain frequency-demodulated colour-difference signals.

# Digital multistandard colour decoder with SCART interface (DMSD2-SCART)

SAA7151B

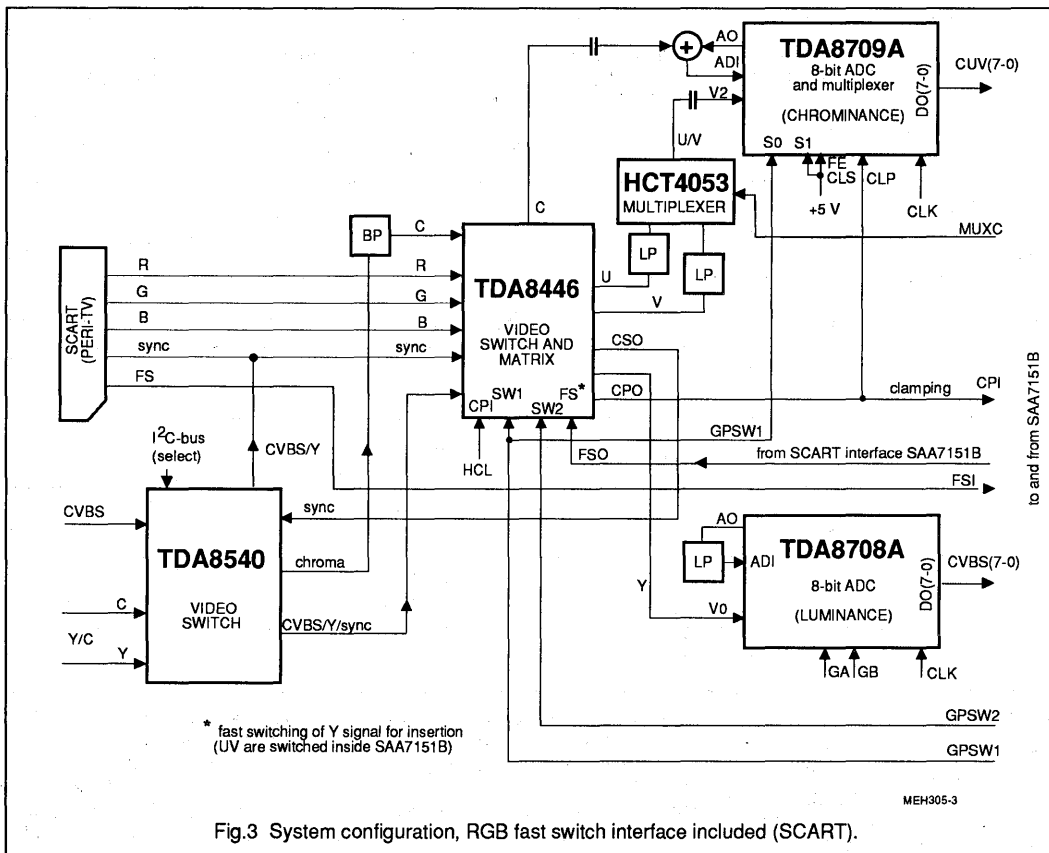

Fig.3 System configuration, RGB fast switch interface included (SCART).

The SECAM signals are fed after de-emphasis to a cross-over switch, to provide the both serial-transmitted colour-difference signals. These signals are finally fed via the fast switch to the output formatter stages and to the output interface. Chrominance signals are output in parallel (4:2:2) on the YUV-bus. The data rate of Y signal (pixel rate) is 13.5 MHz. UV signals have a data rate of 13.5 MHz/2 for the 4:2:2 format (Table 2) respectively 13.5 MHz/4 for the 4:1:1 format (Table 3)

### Component processing and SCART interface control

The 8-bit multiplexed colour-difference input signal (signal CUV, Fig.1, out of matrixed RGB in Fig.3) is fed via the input interface to a chrominance stop filter (UV signal only can pass through; Figures 20 to 22). Here it is clamped and fed to the offset compensation which can be enabled or disabled via the I<sup>2</sup>C-bus.

For matrixed RGB signals – the full screen SCART mode and the fast insertion mode (blanking/switching) are selectable. The chrominance stop filter is automatically bypassed in full screen SCART mode.

### Full screen RGB mode (SCART):

The CUV digital input signal (7-0) consists of time-multiplexed samples for U and V. An offset correction for both signals is applied to correct external clamping errors. An internal timing correction compensates for slight differences in timing during sampling. The U and V signals are delay-compensated and fed to the output formatter. The format 4:2:2 or 4:1:1 is generated by a switchable filter.

The control signals for the front end (Figures 3 and 18) MUXC, status bits FSST1, FSST0 (outputs GPSW2, GPSW1) and FSO are generated by the SAA7151B.

# Digital multistandard colour decoder with SCART interface (DMSD2-SCART)

SAA7151B

Table 1 SCART interface control (Fig.3)

MODE	CONNECTION				chroma output of TDA8446 to TDA8709A	TDA8709A		luminance fast switch TDA8446	input selector (via I <sup>2</sup> C-bus) TDA8540
	FSO	GPSW 2	GPSW 1	MUXC		selected input	CUV (7-0)		
RGB only	0 0	0 0	0 0	0 1	high-Z	VIN2	U/V	sync (RGB)	sync (RGB)
Y/C or CVBS only	0 0	0 0	1 1	0 1	C	VIN1	C	Y (Y/C) or CVBS	Y (Y/C) or CVBS
Fast switch	0 0	1 1	0 0	0 1	C	VIN2	0.5(C+U)/ 0.5(C+V)	Y (Y/C) or CVBS	Y (Y/C) or CVBS
	0 0	1 1	1 1	0 1	not used				
RGB only	1 1	0 0	0 0	0 1	high-Z	VIN2	U/V	Y (RGB)	sync (RGB)
	1 1	0 0	1 1	0 1	not used				
Fast switch	1 1	1 1	0 0	0 1	C	VIN2	0.5(C+U)/ 0.5(C+V)	Y (RGB)	Y (Y/C) or CVBS
	1 1	1 1	1 1	0 1	not used				

**Fast insertion mode:**

Fast insertion is applied by FSI pulse to ensure correct timing. The RGB source signal is matrixed into UV and inserted into the CVBS or Y/C source signal after two field periods if FSI pulses are received. The output FSO is set to HIGH during a determined insertion window (screen plain minus 6 % of horizontal and vertical deflection). Switch over depends on the phase of FSI in relation to the valid pixel sequence depending on the phase-different weighting factors. They are applied to the original and the inserted UV data (Figures 5 and 6)

The control signals for the front end (Table 1) MUXC, FSO, status bits FSST1 and FSST0 (outputs GPSW2 and GPSW1) are generated by the SAA7151B.

The amplitude of chrominance and

colour-difference signals are scaled down by factor 2 to avoid overloading of the chrominance analog-to-digital converter. The amplitudes are reduced in the TDA8446 by signals on lines GPSW2 and GPSW1.

**Luminance processing**

The luminance input signal, a digital CVBS format or an 8-bit luminance format (S-Video), is fed through a sample rate converter to reduce the data rate to 13.5 MHz (Fig.4b).

Sample rate is converted by means of a switchable pre-filter. High frequency components are emphasized to compensate for loss in the following chrominance trap filter. This chrominance trap filter ( $f_o = 4.43$  MHz or  $f_o = 3.58$  MHz centre frequency selectable) eliminates the most of the colour carrier signal, therefore, it must be bypassed for S-Video signals.

The high frequency components of the luminance signal can be "peaked" in two bandpass filters with selectable transfer characteristic. A coring circuit ( $\pm 1$  LSB) can improve the signal, this signal is then added to the original signal. A switchable amplifier achieves a common DC amplification, because the DC gains are different in both chrominance trap modes. Additionally, a cut-off sync pulse is generated for the original signal in both modes.

**Synchronization**

The luminance output signal is fed to the synchronization stage. Its bandwidth is reduced to 1 MHz in a low-pass filter (sync pre-filter). The sync pulses are sliced and fed to the phase detectors to be compared with the sub-divided clock frequency. The resulting output signal is applied to the loop filter to



Digital multistandard colour decoder  
with SCART interface (DMSD2-SCART)

SAA7151B

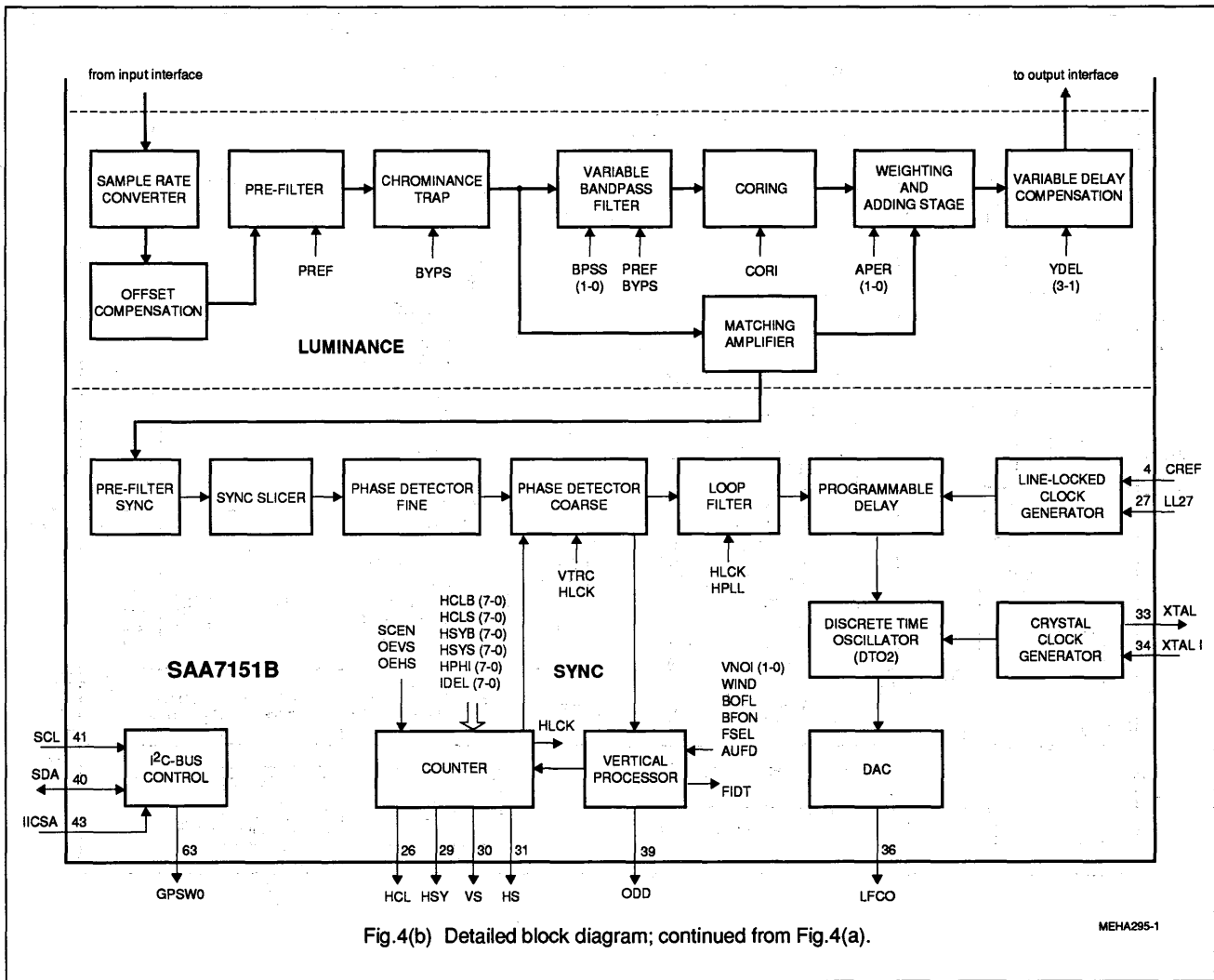

Fig.4(b) Detailed block diagram; continued from Fig.4(a).

# Digital multistandard colour decoder with SCART interface (DMSD2-SCART)

SAA7151B

accumulate all phase deviations. There are three groups of output timing signals:

- a. signals related to data output signals (HREF)
- b. signals related to the input signals (HSY, and HCL)
- c. signals related to the internal sync phase

All horizontal timings are derived from the main counter, which represents the internal sync phase. The HREF signal only with its critical timing is phase-compensated in relationship to the data output signal. Future circuit improvements could slightly influence the processing delays of some internal stages to achieve a changed timing due to the timing groups b and c.

The HREF signal only controls the data multiplexer phase and the data output signals.

**Table 2** for the 4 : 2 : 2 format (720 pixels per line). The quoted frequencies are valid on the YUV-bus. The time frames are controlled by the HREF signal.

OUTPUT	PIXEL BYTE SEQUENCE					
Y0 (LSB)	Y0	Y0	Y0	Y0	Y0	Y0
Y1	Y1	Y1	Y1	Y1	Y1	Y1
Y2	Y2	Y2	Y2	Y2	Y2	Y2
Y3	Y3	Y3	Y3	Y3	Y3	Y3
Y4	Y4	Y4	Y4	Y4	Y4	Y4
Y5	Y5	Y5	Y5	Y5	Y5	Y5
Y6	Y6	Y6	Y6	Y6	Y6	Y6
Y7 (MSB)	Y7	Y7	Y7	Y7	Y7	Y7
UV0 (LSB)	U0	V0	U0	V0	U0	V0
UV1	U1	V1	U1	V1	U1	V1
UV2	U2	V2	U2	V2	U2	V2
UV3	U3	V3	U3	V3	U3	V3
UV4	U4	V4	U4	V4	U4	V4
UV5	U5	V5	U5	V5	U5	V5
UV6	U6	V6	U6	V6	U6	V6
UV7(MSB)	U7	V7	U7	V7	U7	V7
Y frame	0	1	2	3	4	5
UV frame	0		2		4	

All timings of the following diagrams are measured with nominal input signals, for example coming from a pattern generator. Processing delay times are taken between input and data output, respectively between internal sync reference (main counter = 0) and the rising edge of HREF.

**Line locked clock frequency**

LFCO is required in an external PLL (SAA7157) to generate the line-locked clock frequency LL27 and CREF.

**YUV-bus, digital outputs**

The 16-bit YUV-bus transfers digital data from the output interfaces to a feature box, or to the digital-to-analog converter (DAC). Outputs are controlled via the I<sup>2</sup>C-bus in normal selections, or they are controlled by output enable chain (FEIN, pin 64). The YUV-bus data rate 13.5 MHz. Timing is achieved by marking each

second positive rising edge of the clock LL27 synchronized by CREF.

**YUV-bus formats**

4 : 2 : 2 and 4 : 1 : 1

The output signals Y7 to Y0 are the bits of the digital luminance signal. The output signals UV7 to UV0 are the bits of the digital colour-difference signal. The frames in the Tables 2 and 3 are the time to transfer a full set of samples. In case of 4 : 2 : 2 format two luminance samples are transmitted in comparison to one U and one V sample within one frame. The time frames are controlled by the HREF signal, which determines the correct UV data phase. The YUV data outputs can be enabled or set to 3-state position by means of the FEIN signal. FEIN = LOW enables the output; HIGH on this pin forces the Y and U/V outputs to a high-impedance state (Fig.5).

**Table 3** for the 4 : 1 : 1 format (720 pixels per line). The quoted frequencies are valid on the YUV-bus. The time frames are controlled by the HREF signal.

OUTPUT	PIXEL BYTE SEQUENCE							
Y0 (LSB)	Y0	Y0	Y0	Y0	Y0	Y0	Y0	Y0
Y1	Y1	Y1	Y1	Y1	Y1	Y1	Y1	Y1
Y2	Y2	Y2	Y2	Y2	Y2	Y2	Y2	Y2
Y3	Y3	Y3	Y3	Y3	Y3	Y3	Y3	Y3
Y4	Y4	Y4	Y4	Y4	Y4	Y4	Y4	Y4
Y5	Y5	Y5	Y5	Y5	Y5	Y5	Y5	Y5
Y6	Y6	Y6	Y6	Y6	Y6	Y6	Y6	Y6
Y7 (MSB)	Y7	Y7	Y7	Y7	Y7	Y7	Y7	Y7
UV0 (LSB)	0	0	0	0	0	0	0	0
UV1	0	0	0	0	0	0	0	0
UV2	0	0	0	0	0	0	0	0
UV3	0	0	0	0	0	0	0	0
UV4	V6	V4	V2	V0	V6	V4	V2	V0
UV5	V7	V5	V3	V1	V7	V5	V3	V1
UV6	U6	U4	U2	U0	U6	U4	U2	U0
UV7 (MSB)	U7	U5	U3	U1	U7	U5	U3	U1
Y frame	0	1	2	3	4	5	6	7
UV frame	0				4			

# Digital multistandard colour decoder with SCART interface (DMSD2-SCART)

SAA7151B

### Signal levels (Figures 11 and 12)

The nominal input and output signal levels are defined by a colour bar signal with 75 % colour, 100 % saturation and 100 % luminance amplitude (EBU colour bar).

### CUV-bus input format

The CUV-bus transfers the digital chrominance/colour-difference

signals from the ADC to the SAA7151B (Fig.5; Table 1):

- normal mode for digital chrominance transmission.
- UV colour-difference mode for colour-difference signals UV (out of matrixed RGB signals)
- FS mode (fast switch mode; UV inserted into chrominance signal C with addition of the two signal spectra).

### RTCO output

The RTCO output signal (Fig.9) contains serialized information about actual clock frequency, subcarrier frequency and PAL/SECAM sequence. This signal may preferably be used with the frequency-locked digital video encoder SAA7199B.

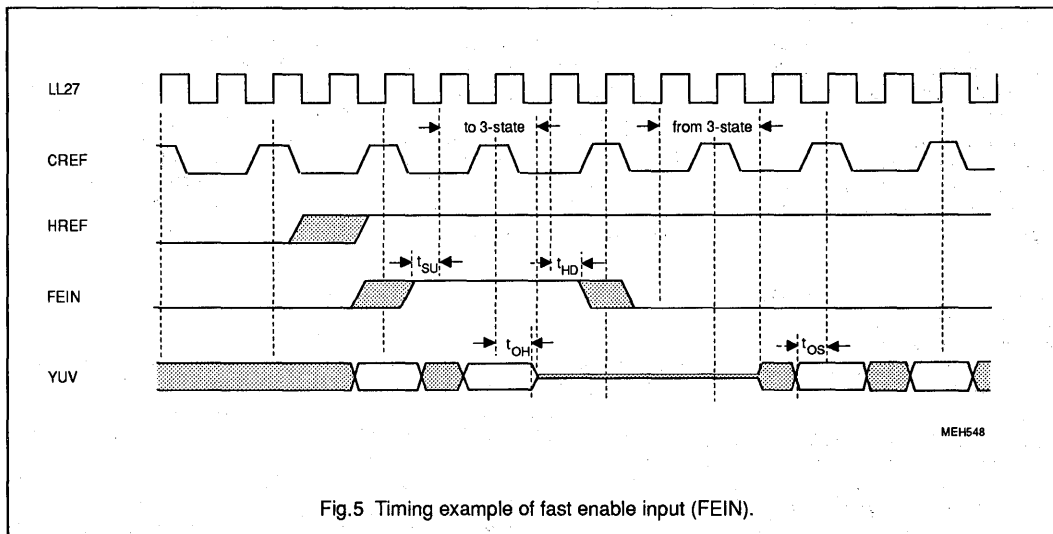

Fig.5 Timing example of fast enable input (FEIN).



# Digital multistandard colour decoder with SCART interface (DMSD2-SCART)

SAA7151B

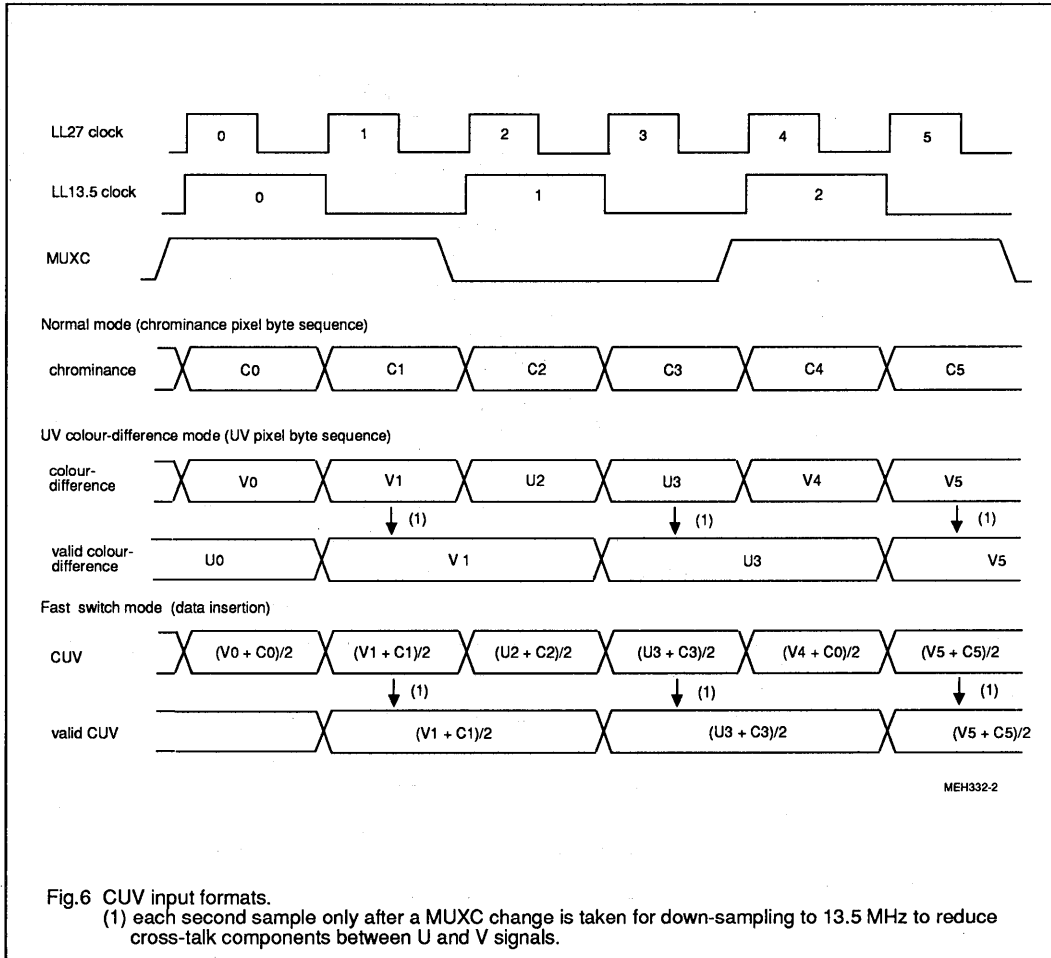
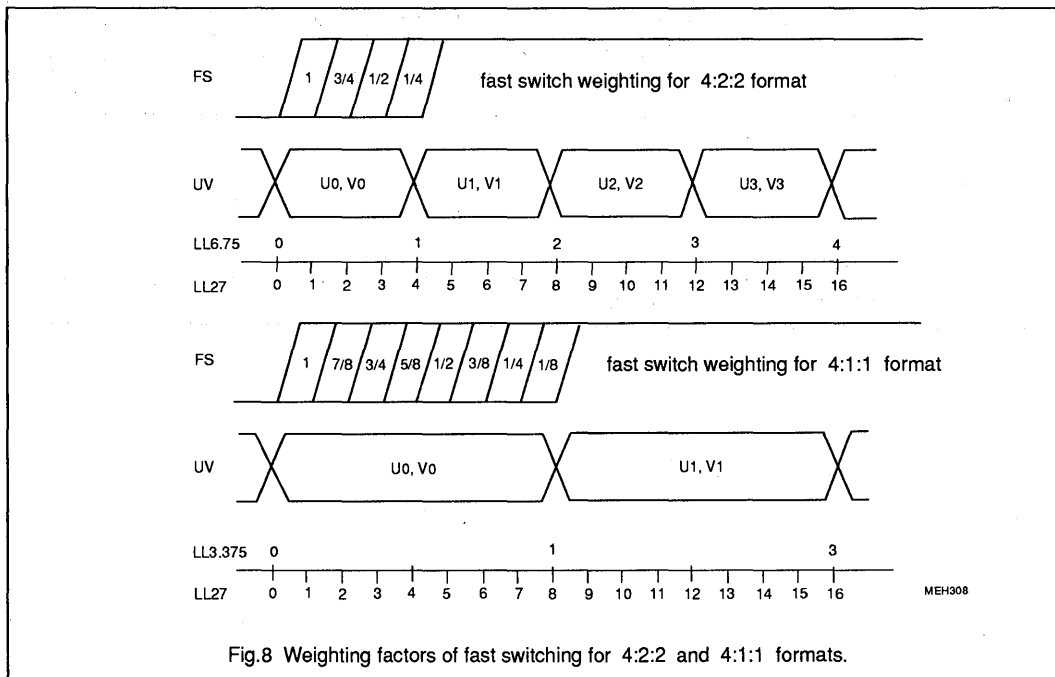
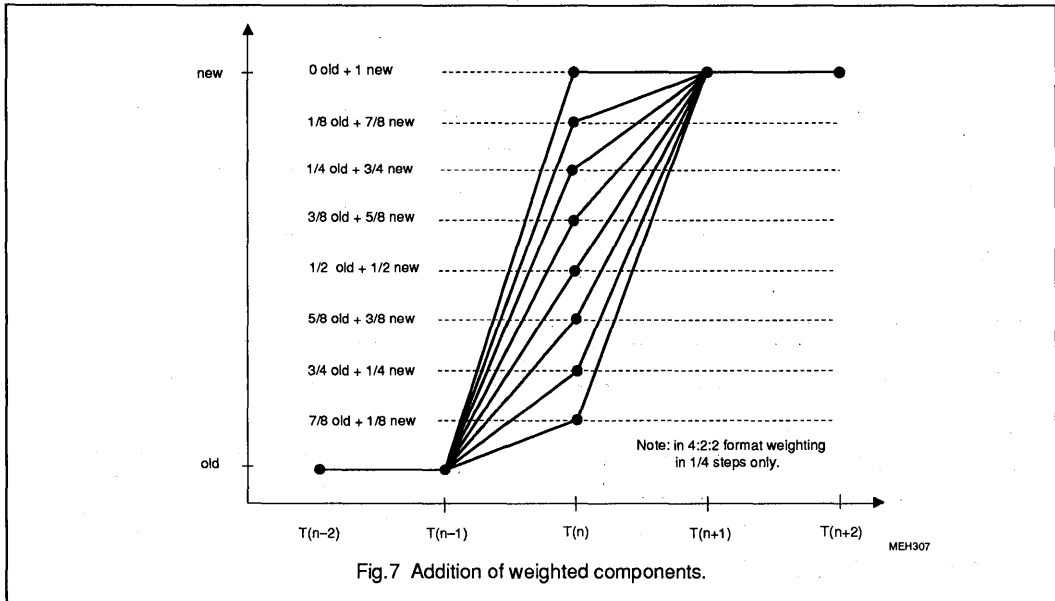

Fig.6 CUV input formats.

(1) each second sample only after a MUXC change is taken for down-sampling to 13.5 MHz to reduce cross-talk components between U and V signals.

# Digital multistandard colour decoder with SCART interface (DMSD2-SCART)

SAA7151B



# Digital multistandard colour decoder with SCART interface (DMSD2-SCART)

SAA7151B

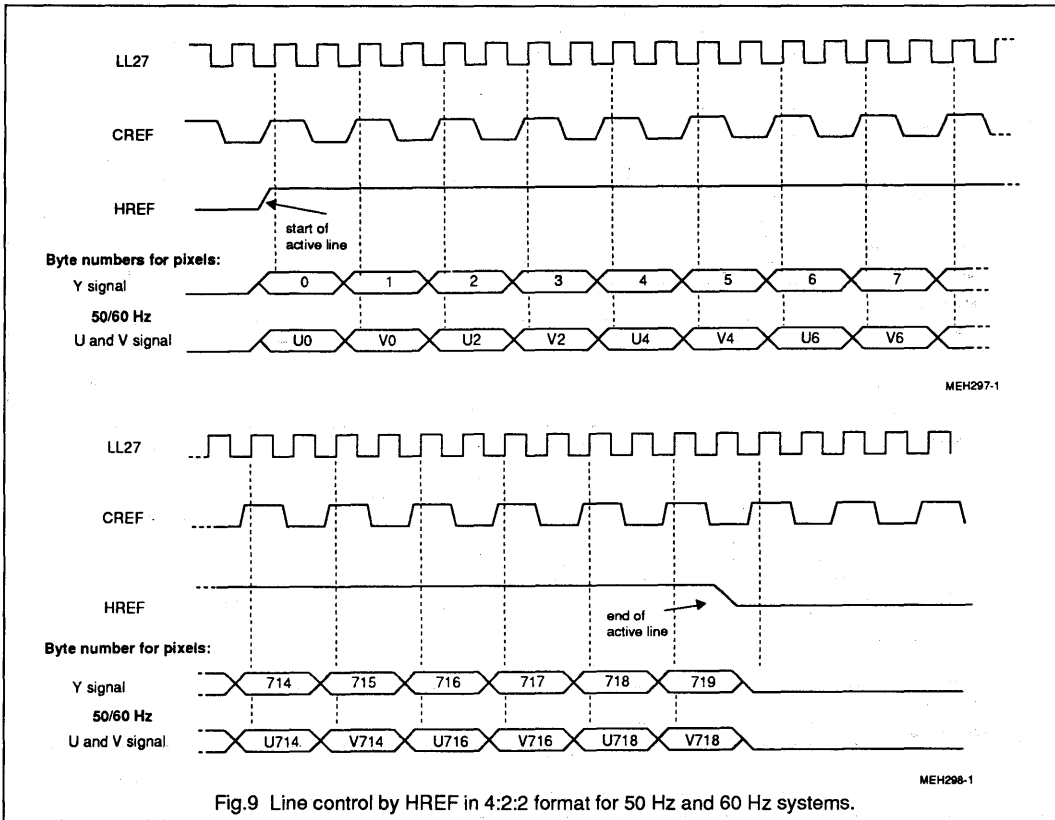

Fig.9 Line control by HREF in 4:2:2 format for 50 Hz and 60 Hz systems.

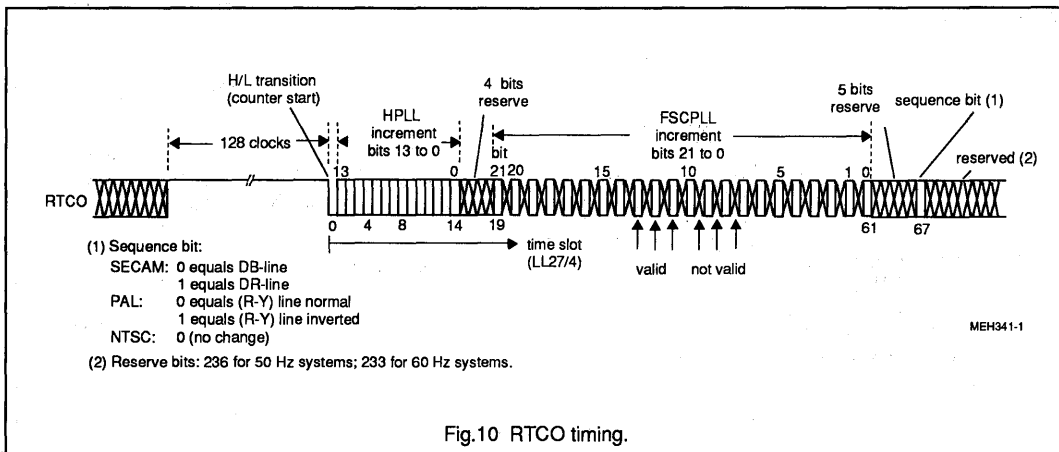

Fig.10 RTCO timing.

# Digital multistandard colour decoder with SCART interface (DMSD2-SCART)

SAA7151B

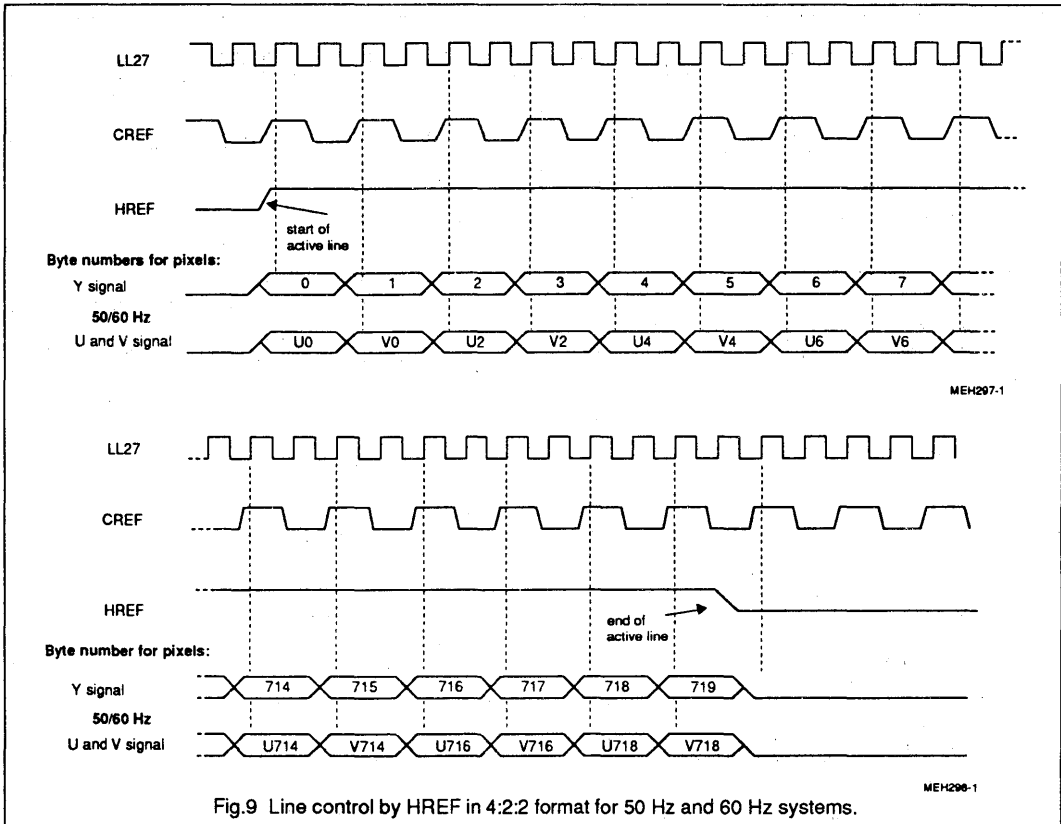

Fig.9 Line control by HREF in 4:2:2 format for 50 Hz and 60 Hz systems.

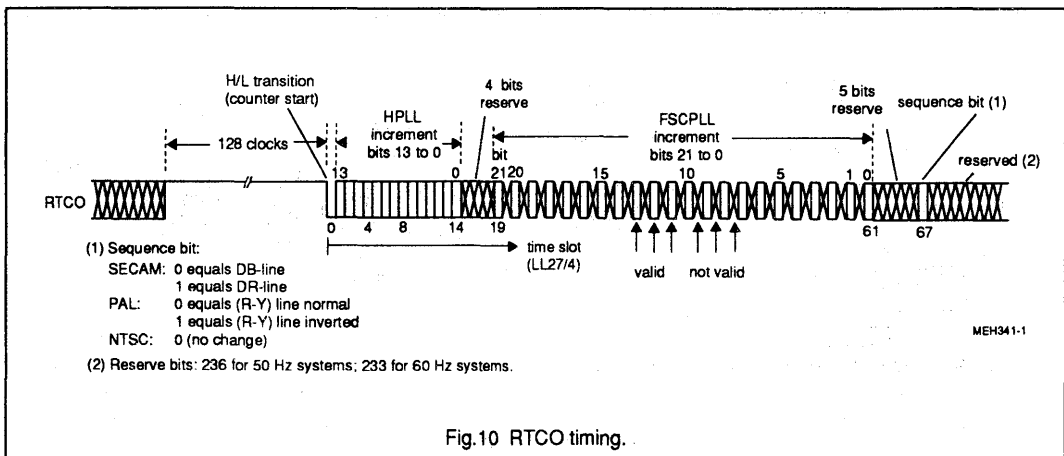
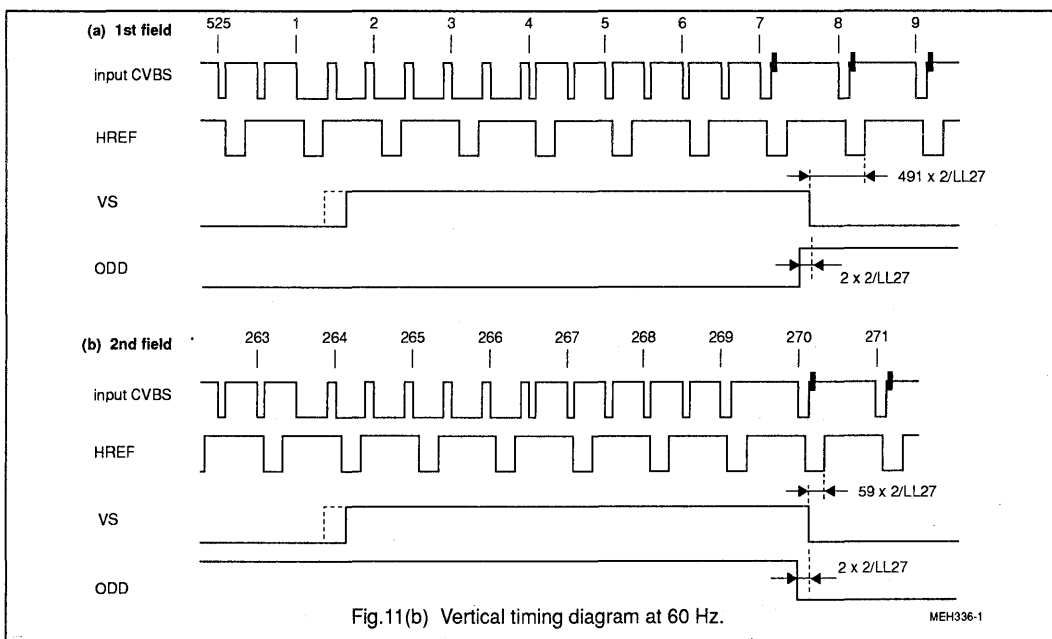
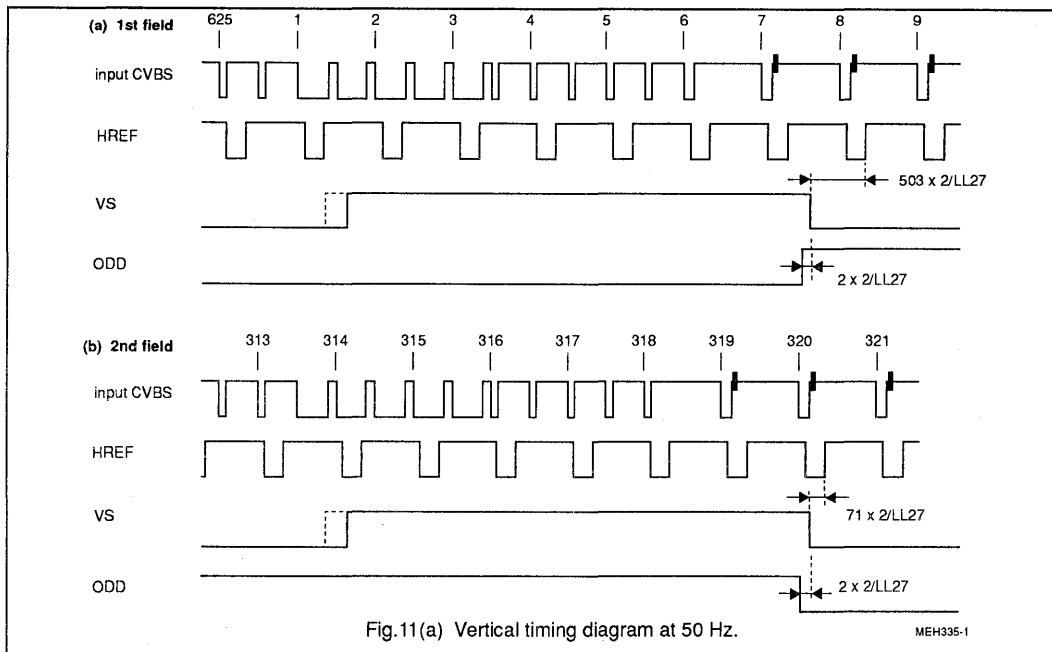

Fig.10 RTCO timing.

# Digital multistandard colour decoder with SCART interface (DMSD2-SCART)

SAA7151B



# Digital multistandard colour decoder with SCART interface (DMSD2-SCART)

SAA7151B

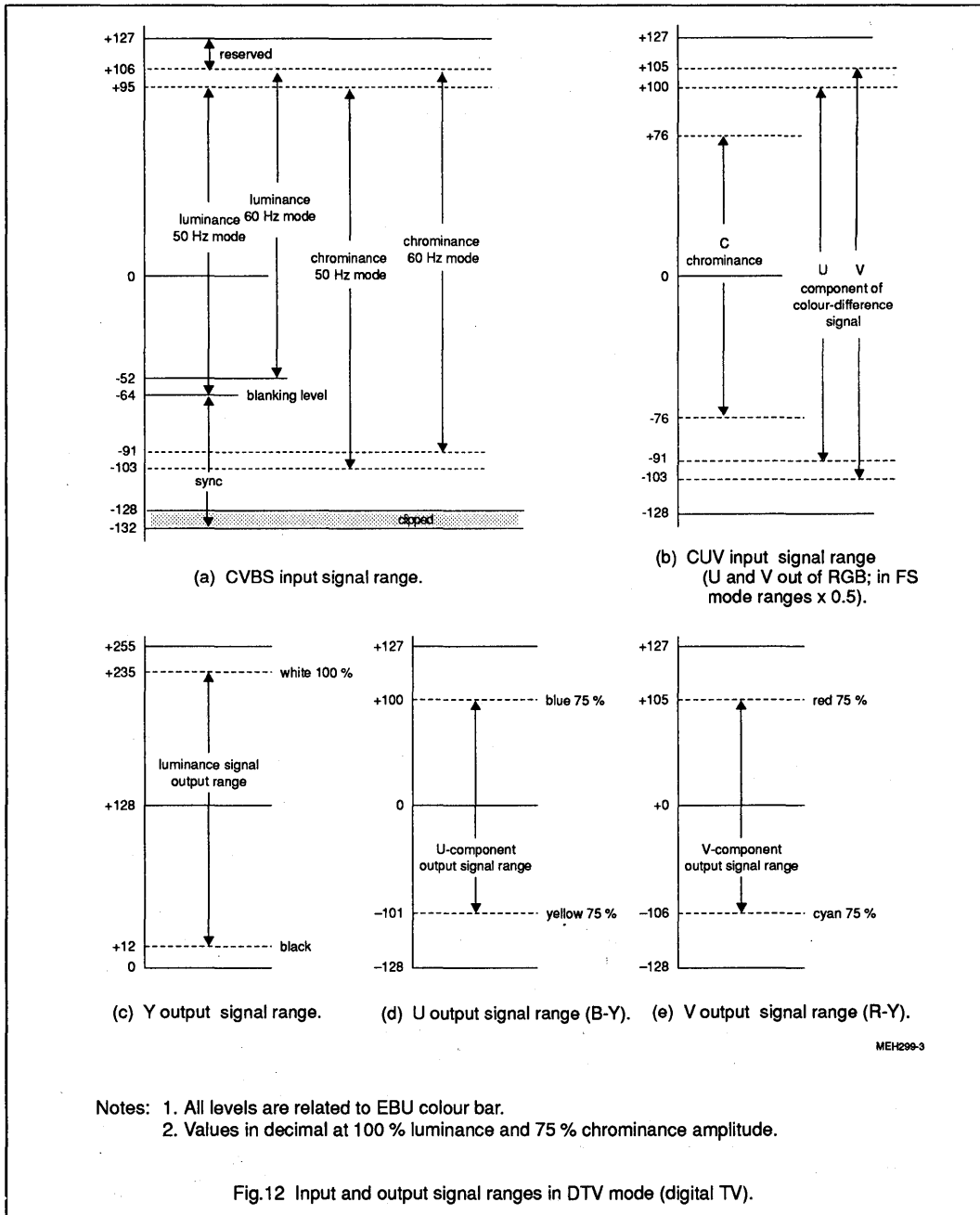

# Digital multistandard colour decoder with SCART interface (DMSD2-SCART)

SAA7151B

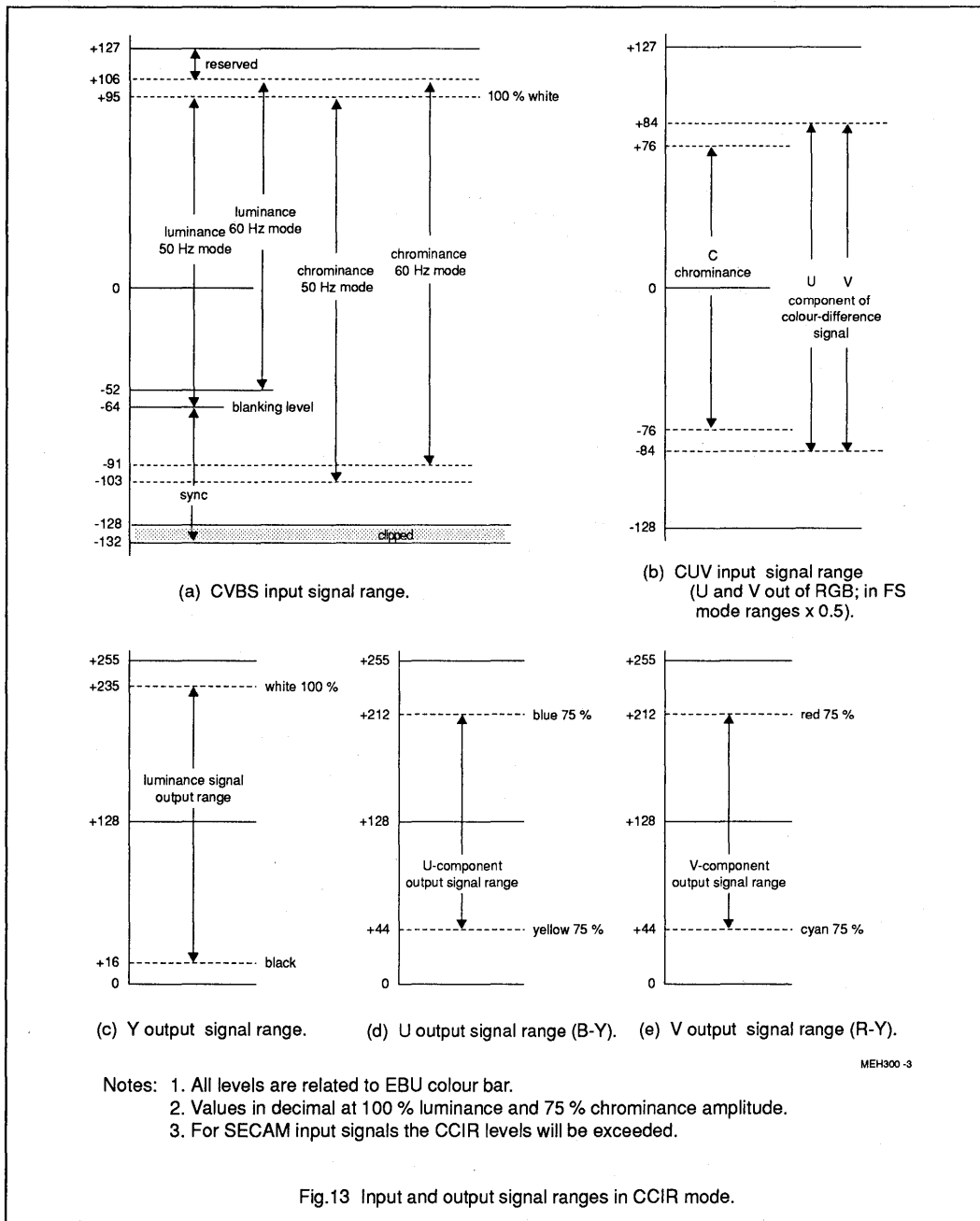

Fig.13 Input and output signal ranges in CCIR mode.

# Digital multistandard colour decoder with SCART interface (DMSD2-SCART)

SAA7151B

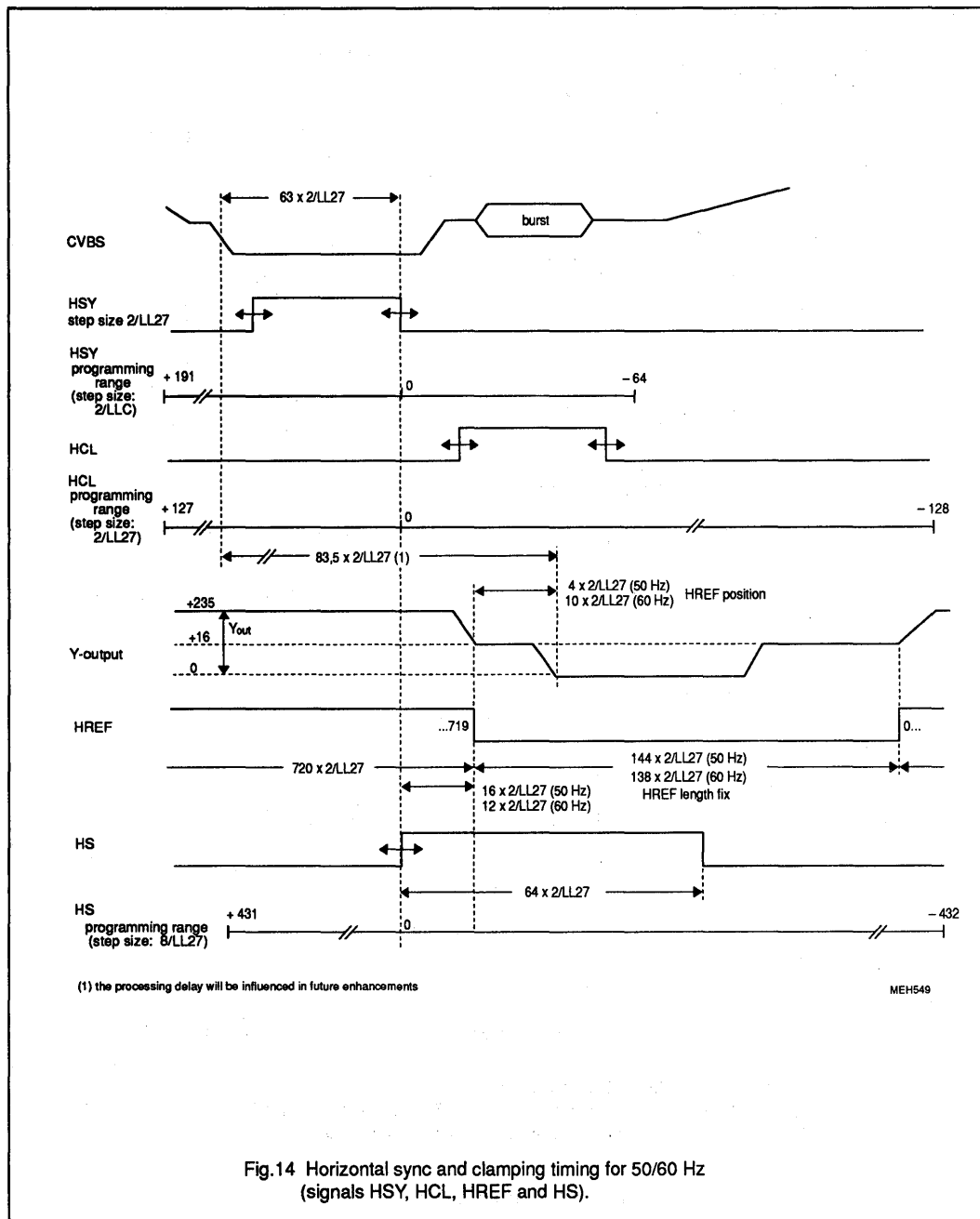

Fig.14 Horizontal sync and clamping timing for 50/60 Hz (signals HSY, HCL, HREF and HS).



# Digital multistandard colour decoder with SCART interface (DMSD2-SCART)

SAA7151B

## 8. LIMITING VALUES

In accordance with the Absolute Maximum Rating system (IEC 134); ground pins 19, 35, 38, 51 and 67 as well as supply pins 5, 18, 28, 37 and 52 connected together.

SYMBOL	PARAMETER	MIN.	MAX.	UNIT
$V_{DD}$	supply voltage (pins 5, 18, 28, 37, 52)	-0.5	7.0	V
$V_{diff\ GND}$	difference voltage $V_{SSA} - V_{SS(1\ to\ 4)}$	-	$\pm 100$	mV
$V_I$	voltage on all inputs	-0.5	$V_{DD}+0.5$	V
$V_O$	voltage on all outputs ( $I_{O\ max} = 20\ mA$ )	-0.5	$V_{DD}+0.5$	V
$P_{tot}$	total power dissipation	-	2.5	W
$T_{stg}$	storage temperature range	-65	150	°C
$T_{amb}$	operating ambient temperature range	0	70	°C
$V_{ESD}$	electrostatic handling* for all pins	-	$\pm 2000$	V

## 9. CHARACTERISTICS $V_{DD} = 4.5\ to\ 5.5\ V$ ; $T_{amb} = 0\ to\ 70\ ^\circ C$ unless otherwise specified.

SYMBOL	PARAMETER	CONDITIONS	MIN.	TYP.	MAX.	UNIT
$V_{DD}$	supply voltage range (pins 5, 18, 28, 37, 52)		4.5	5	5.5	V
$I_{DD}$	total supply current (pins 5, 18, 28, 37, 52)	$V_{DD} = 5\ V$ ; inputs LOW; outputs not connected	-	100	250	mA
<b>I<sup>2</sup>C-bus, SDA and SCL (pins 40 and 41)</b>						
$V_{IL}$	input voltage LOW		-0.5	-	1.5	V
$V_{IH}$	input voltage HIGH		3	-	$V_{DD}+0.5$	V
$I_{40,41}$	input current		-	-	$\pm 10$	$\mu A$
$I_{ACK}$	output current on pin 40	acknowledge	3	-	-	mA
$V_{OL}$	output voltage at acknowledge	$I_{40} = 3\ mA$	-	-	0.4	V
<b>Data, clock and control inputs (pins 3, 4, 6 to 17, 20 to 23, 27, 34, 64 and 68); Figures 12 and 13</b>						
$V_{IL}$	LL27 input voltage (pin 27)	LOW	-0.5	-	0.6	V
$V_{IH}$		HIGH	2.4	-	$V_{DD}+0.5$	V
$V_{IL}$	other input voltages	LOW	-0.5	-	0.8	V
$V_{IH}$		HIGH	2.0	-	$V_{DD}+0.5$	V
$I_{leak}$	input leakage current		-	-	10	$\mu A$
$C_I$	input capacitance	data inputs; note 1	-	-	8	pF
		I/O high-impedance	-	-	8	pF
		clock inputs	-	-	10	pF
$t_{SU,DAT}$	input data set-up time	Fig.15	11	-	-	ns
$t_{HD,DAT}$	input data hold time		3	-	-	ns

\* Equivalent to discharging a 100 pF capacitor through a 1.5 k $\Omega$  series resistor.; inputs and outputs are protected against electrostatic discharge in normal handling. Normal precautions appropriate to handle MOS devices is recommended ("Handling MOS Devices").

# Digital multistandard colour decoder with SCART interface (DMSD2-SCART)

SAA7151B

SYMBOL	PARAMETER	CONDITIONS	MIN.	TYP.	MAX.	UNIT
<b>YUV-bus, HREF and VS outputs</b> (pins 30, 42, 45 to 50 and pins 53 to 62), Figures 9 and 12 to 13						
$V_{OL}$	output voltage LOW	notes 1 and 2	0	-	0.6	V
$V_{OH}$	output voltage HIGH		2.4	-	$V_{DD}$	V
$C_L$	load capacitor		15	-	50	pF
<b>LFCO output</b> (pin 36)						
$V_o$	output signal (peak-to-peak value)	note 2	1.4	-	2.6	V
$V_{36}$	output voltage range		1	-	$V_{DD}$	V
<b>Control outputs</b> (pins 24 to 26, 29, 31, 32, 33, 39, 63, 65 and 66); Fig.11, 14 and 15						
$V_{OL}$	output voltage LOW	notes 1 and 2	0	-	0.6	V
$V_{OH}$	output voltage HIGH		2.4	-	$V_{DD}$	V
$C_L$	load capacitor		7.5	-	25	pF
<b>Timing of YUV-bus and control outputs</b>			Figures 9 and 11			
$t_{OH}$	output signal hold time	YUV, HREF, VS at $C_L = 15$ pF; controls at $C_L = 7.5$ pF	13 13	- -	- -	ns ns
$t_{OS}$	output set-up time	YUV, HREF, VS at $C_L = 50$ pF; controls at $C_L = 25$ pF	20 20	- -	- -	ns ns
$t_{SZ}$	data output disable transition time	to 3-state condition	22	-	-	ns
$t_{ZS}$	data output enable transition time	from 3-state condition	20	-	-	ns
<b>Chrominance PLL</b>						
$f_C$	catching range		$\pm 400$	-	-	Hz
<b>Crystal oscillator</b>			Figures 17 and 18; note 3			
$f_n$	nominal frequency	3rd harmonic	-	24.576	-	MHz
$\Delta f / f_n$	permissible deviation $f_n$		-	-	$\pm 50$	$10^{-6}$
	temperature deviation from $f_n$		-	-	$\pm 20$	$10^{-6}$
X1	crystal specification:					
	temperature range $T_{amb}$		0	-	70	$^{\circ}C$
	load capacitance $C_L$		8	-	-	pF
	series resonance resistance $R_S$		-	40	80	$\Omega$
	motional capacitance $C_1$		-	$1.5 \pm 20\%$	-	fF
	parallel capacitance $C_0$		-	$3.5 \pm 20\%$	-	pF

# Digital multistandard colour decoder with SCART interface (DMSD2-SCART)

SAA7151B

SYMBOL	PARAMETER	CONDITIONS	MIN.	TYP.	MAX.	UNIT
<b>Line locked clock input LL27 (pin 27)</b>		Fig.8 and 15				
$t_{LL27}$	cycle time	note 4	35	-	39	ns
$t_p$	duty factor	$t_{LL27H} / t_{LL27}$	40	50	60	%
$t_r$	rise time		-	-	5	ns
$t_f$	fall time		-	-	6	ns

### Notes to the characteristics

- Data output signals are Y7 to Y0 and UV7 to UV0. All other are control output signals.
- Levels are measured with load circuit. YUV-bus, HREF and VS outputs with 1.2 k $\Omega$  in parallel to 50 pF at 3 V (TTL load); LFCO output with 10 k $\Omega$  in parallel to 15 pF and other outputs with 1.2 k $\Omega$  in parallel to 25 pF at 3 V (TTL load).
- Recommended crystal: Philips 4322 143 05291.
- $t_{SU}$ ,  $t_{HD}$ ,  $t_{OH}$  and  $t_{OD}$  include  $t_r$  and  $t_f$ .

**Table 4** High-impedance control for YUV-bus (Fig.15)

OEDY	OEDC	FEIN	Y(7:0)	UV(7:0)
0	0	0	Z	Z
0	1	0	Z	active
1	0	0	active	Z
1	1	0	Z	Z
X	X	1	Z	Z

# Digital multistandard colour decoder with SCART interface (DMSD2-SCART)

SAA7151B

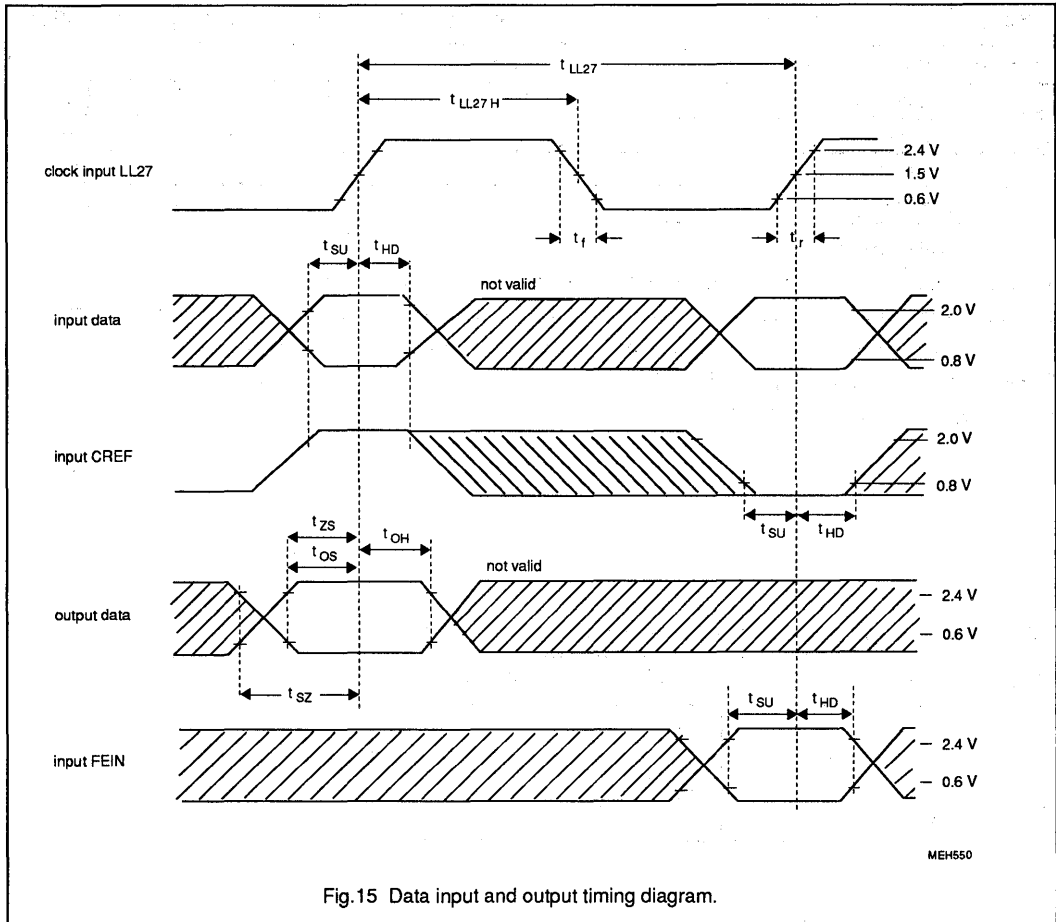

Fig.15 Data input and output timing diagram.

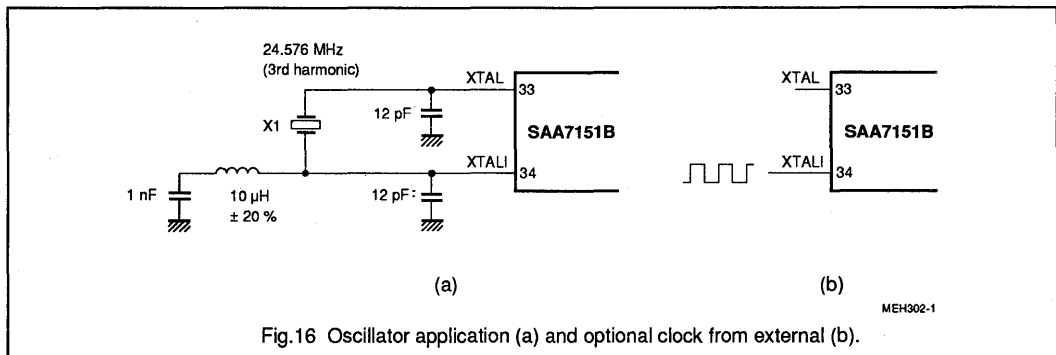

Fig.16 Oscillator application (a) and optional clock from external (b).

# Digital multistandard colour decoder with SCART interface (DMSD2-SCART)

## SAA7151B

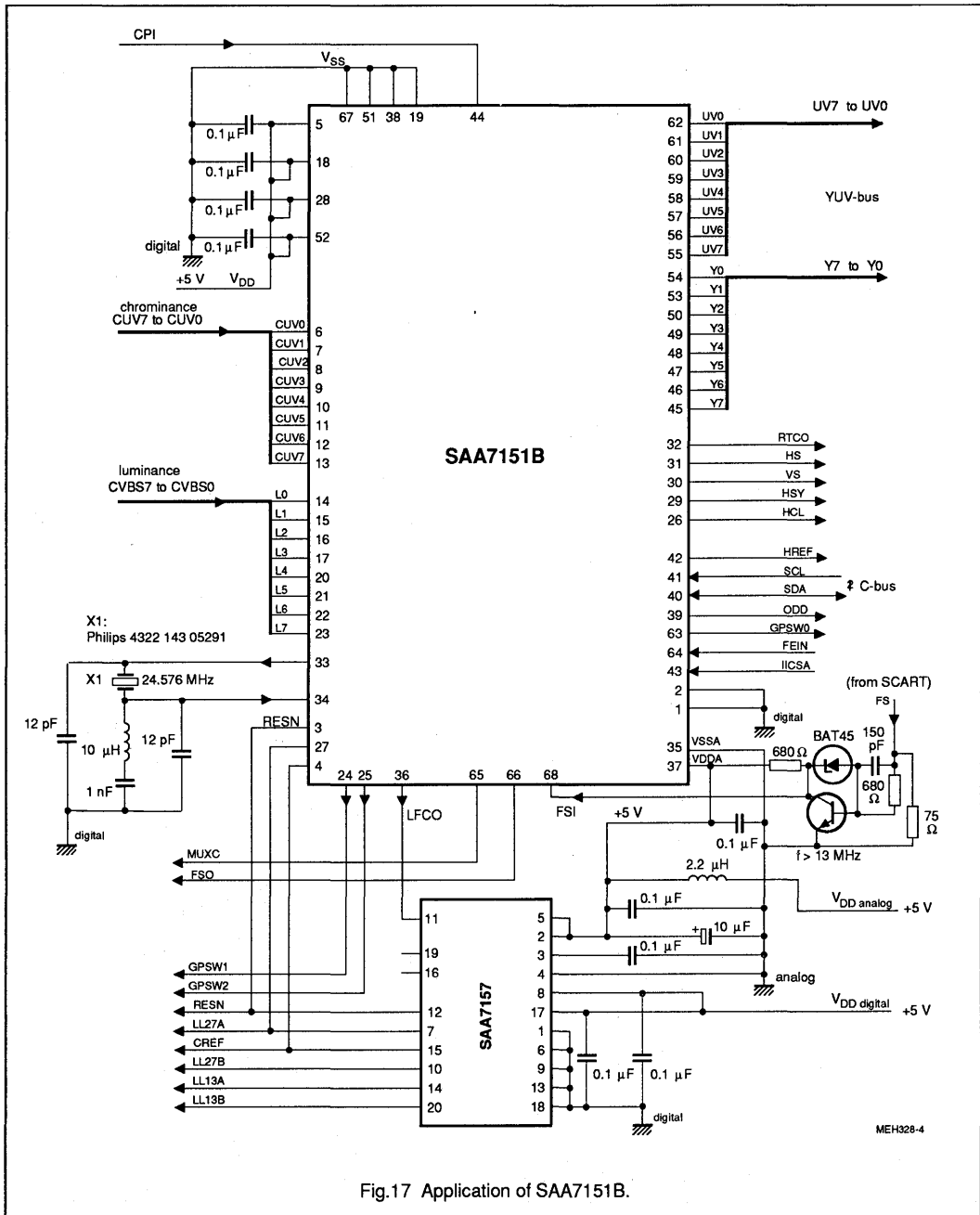

Fig.17 Application of SAA7151B.

# Digital multistandard colour decoder with SCART interface (DMSD2-SCART)

SAA7151B

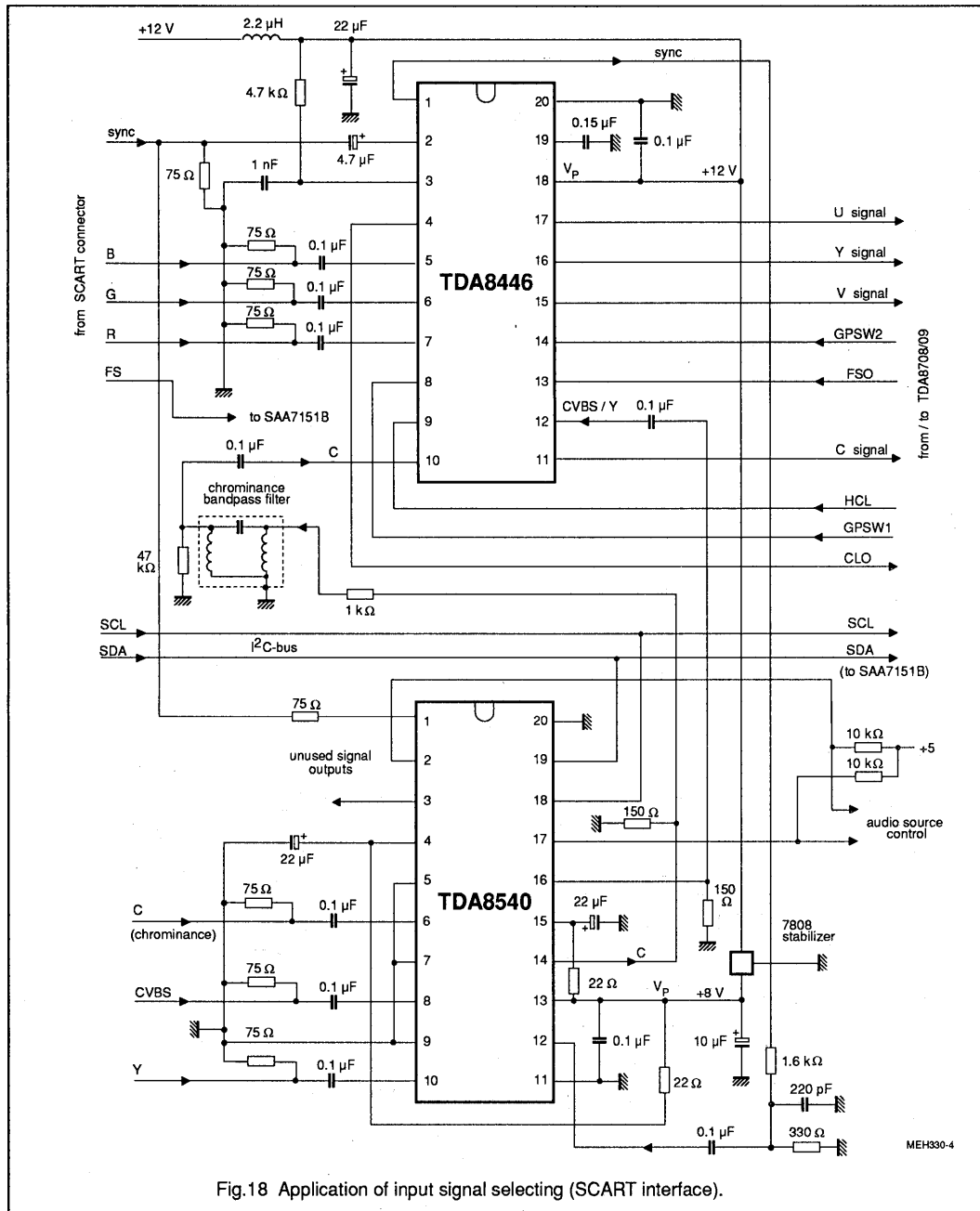

Fig.18 Application of input signal selecting (SCART interface).

Digital multistandard colour decoder with SCART interface (DMSD2-SCART)

SAA7151B

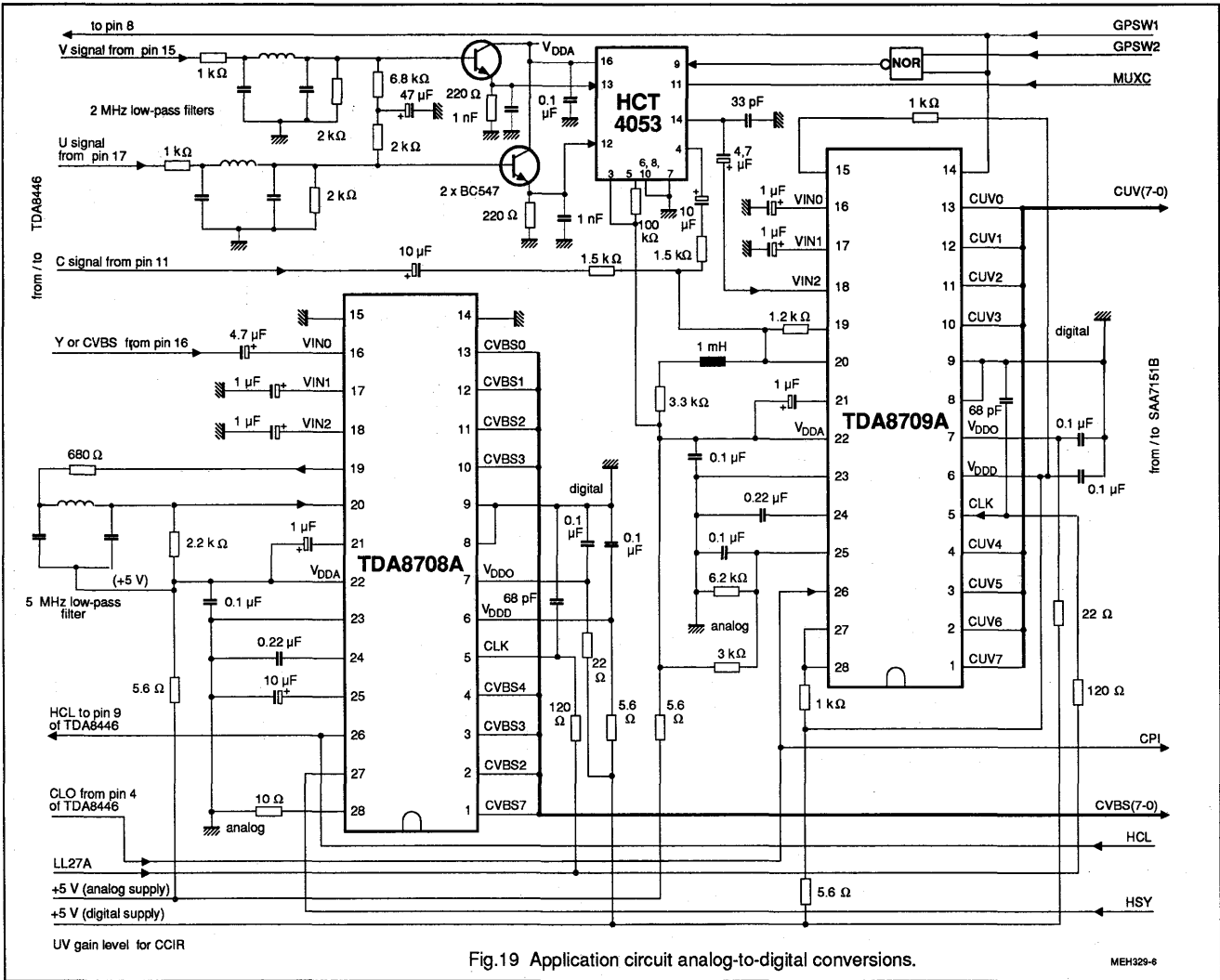

Fig.19 Application circuit analog-to-digital conversions.

MEH329-8

# Digital multistandard colour decoder with SCART interface (DMSD2-SCART)

SAA7151B

## 10. I<sup>2</sup>C-BUS FORMAT

S	SLAVE ADDRESS	A	SUBADDRESS	A	DATA0	A		DATA <sub>n</sub>	A	P
---	---------------	---	------------	---	-------	---	--	-------------------	---	---

- S = start condition
- SLAVE ADDRESS = **1000 101X** (IICSA = LOW) or **1000 111X** (IICSA = HIGH)
- A = acknowledge, generated by the slave
- SUBADDRESS\* = subaddress byte (Table 5)
- DATA = data byte (Table 5)
- P = stop condition
  
- X = read/write control bit
  - X = 0, order to write (the circuit is slave receiver)
  - X = 1, order to read (the circuit is slave transmitter)

\* If more than 1 byte DATA are transmitted, then auto-increment of the subaddress is performed.

- Remarks:
- Prior to reset of the IC all outputs are undefined.
  - After power-on reset, the control register 12 (hex) is set to 00 (hex).

**Table 5** I<sup>2</sup>C-bus; DATA for status byte (X in address byte = 1; slave address 8B (hex) at IICSA = LOW or 8F (hex) at IICSA = HIGH)

FUNCTION		DATA							
		D7	D6	D5	D4	D3	D2	D1	D0
status byte		STTC	HLCK	FIDT	FSST1	FSST0	CDET2	CDET1	CDET0

Function of the bits:							
STTC	Status time constant (to be used for gogical combfilter SAA7152)					0 = TV mode; 1 = VCR mode	
HLCK	Horizontal PLL information:					0 = HPLL locked; 1 = HPLL unlocked	
FIDT	Field information:					0 = 50 Hz system detected; 1 = 60 Hz system detected	
FSST1 to FSST0	Fast swiching output mode:	FSST1	FSST0	mode			
		0	0	RGB; FSI = HIGH (pin 68)			
		0	1	Y/C; FSI = LOW (pin 68)			
		1	0	fast switching (toggle)			
		1	1	not used			
CDET2 to CDET0	Identified colour standard	CDET2	CDET2	CDET2	standard		
		0	0	0	PAL-B/G, -H, -I; 50 Hz		
		0	0	1	PAL-N; 50 Hz		
		0	1	0	SECAM; 50 Hz		
		0	1	1	PAL-M; 60 Hz		
		1	0	0	PAL 4.43; 60 Hz		
		1	0	1	NTSC-M; 60 Hz		
		1	1	0	NTSC 4.43; 60 Hz		
		1	1	1	black/white		



# Digital multistandard colour decoder with SCART interface (DMSD2-SCART)

SAA7151B

**Table 6** I<sup>2</sup>C-bus; subaddress and data bytes for writing (X in address byte = 0; slave address 8A (hex) at IICSA = LOW or 8E at IICSA = HIGH)

function	subaddress byte	data byte							
		D7	D6	D5	D4	D3	D2	D1	D0
increment delay	00	IDEL7	IDEL6	IDEL5	IDEL4	IDEL3	IDEL2	IDEL1	IDEL0
H-sync HSY begin	01	HSYB7	HSYB6	HSYB5	HSYB4	HSYB3	HSYB2	HSYB1	HSYB0
H-sync HSY stop	02	HSYS7	HSYS6	HSYS5	HSYS4	HSYS3	HSYS2	HSYS1	HSYS0
H-clamp HCL begin	03	HCLB7	HCLB6	HCLB5	HCLB4	HCLB3	HCLB2	HCLB1	HCLB0
H-clamp HCL stop	04	HCLS7	HCLS6	HCLS5	HCLS4	HCLS3	HCLS2	HCLS1	HCLS0
H-sync after PHI1	05	HPHI7	HPHI6	HPHI5	HPHI4	HPHI3	HPHI2	HPHI1	HPHI0
luminance control	06	BYPS	PREF	BPSS1	BPSS0	BFBY	CORI	APER1	APER0
hue control	07	HUEC7	HUEC6	HUEC5	HUEC4	HUEC3	HUEC2	HUEC1	HUEC0
miscellaneous controls #1	08	CSTD2	CSTD1	CSTD0	CKTQ4	CKTQ3	CKTQ2	CKTQ1	CKTQ0
miscellaneous controls #2	09	OSCE	LFIS1	LFIS0	CKTS4	CKTS3	CKTS2	CKTS1	CKTS0
PAL switch sensitivity	0A	PLSE7	PLSE6	PLSE5	PLSE4	PLSE3	PLSE2	PLSE1	PLSE0
SECAM switch sensitivity	0B	SESE7	SESE6	SESE5	SESE4	SESE3	SESE2	SESE1	SESE0
miscellaneous controls #3	0C	FSAU	GPSI2	GPSI1	CGFX	AMPF3	AMPF2	AMPF1	AMPF0
miscellaneous controls #4	0D	COLO	CHSB	GPSW0	SUVI	SXCR	FSDL2	FSDL1	FSDL0
miscellaneous controls #5	0E	CCIR	COFF	OEHS	OEVS	UVSS	CHRS	CDMO	CDPO
miscellaneous controls #6	0F	AUFD	FSEL	HPLL	SCEN	VTRC	MUIV	FSIV	WIND
miscellaneous controls #7	10	ASTD	OFTS	IPBP	CDVI	YDEL3	YDEL2	YDEL1	YDEL0
chroma gain reference	11	CHCV7	CHCV6	CHCV5	CHCV4	CHCV3	CHCV2	CHCV1	CHCV0
miscellaneous controls #8	12	OEDY	OEDC	VNOI1	VNOI0	BFON	BOFL2	BOFL1	BOFL0

**Function of the bits of Table 6**

IDEL7 to IDEL0 "00"	Increment delay time , step size = 4/LL27 = 148 ns*								decimal multiplier	note
	D7	D6	D5	D4	D3	D2	D1	D0		
1 1 1 1	1	1	1	1	1	1	1	1		minimum -148 ns
1 0 0 1	0	0	1	0	0	1	0	0	-110	-16.3 μs (outside available range)
1 0 0 1	0	0	1	0	0	0	1	0	-111 to -214	-16.44 μs
0 0 1 0	1	0	1	0	1	0	0	0	-215	-31.7 μs (maximum value at FSEL = 1 )
0 0 1 0	1	0	0	1	0	0	1	0	-215	-31.85 μs (outside central counter range at FSEL = 1 **)
0 0 1 0	1	0	0	0	0	0	0	0	-216	-32.0 μs (maximum value at FSEL = 0 **)
0 0 1 0	0	1	1	1	1	1	1	1	-217 to -256	-32.148 μs (outside central counter range at FSEL = 0 **)
0 0 0 0	0	0	0	0	0	0	0	0	-217 to -256	-37.9 μs (outside central counter **)

\* an internal sign-bit D8 set to HIGH indicates that all values are always negative  
 \*\* H-PLL does not operate in this condition; the system clock frequency is set to a value fixed by the last update and is within ±7.1 % of the nominal frequency.

# Digital multistandard colour decoder with SCART interface (DMSD2-SCART)

SAA7151B

HSYB7 to HSYB0 HSYS7 to HSYS0 "01" and "02"	Horizontal sync begin, step size = $2/LL27 = 74$ ns		
	Horizontal sync stop, step size = $2/LL27 = 74$ ns		
	D7 D6 D5 D4 D3 D2 D1 D0	decimal multiplier	note
	1 0 1 1 1 1 1 1	191 to 1	-14.2 $\mu$ s (maximum negative value)
	0 0 0 0 0 0 0 1	0	-74 ns
0 0 0 0 0 0 0 0	0	0 equals reference value	
1 1 1 1 1 1 1 1	-1 to -64	+74 ns	
1 1 0 0 0 0 0 0		+4.7 $\mu$ s	
HCLB7 to HCLB0 HCLS7 to HCLS0 "03" and "04"	Horizontal clamp begin, step size = $2/LL27 = 74$ ns		
	Horizontal clamp stop, step size = $2/LL27 = 74$ ns		
	D7 D6 D5 D4 D3 D2 D1 D0	decimal multiplier	note
	0 1 1 1 1 1 1 1	127 to 1	-9.4 $\mu$ s (maximum negative value)
	0 0 0 0 0 0 0 1	0	-74 ns
0 0 0 0 0 0 0 0	0	0 equals reference value	
1 1 1 1 1 1 1 1	-1 to -128	+74 ns	
1 0 0 0 0 0 0 0		+9.5 $\mu$ s (maximum positive value)	
HPHI7 to HPHI0 "05"	Horizontal sync start, step size = $8/LL27 = 296$ ns		
	D7 D6 D5 D4 D3 D2 D1 D0	decimal multiplier	note
	0 1 1 1 1 1 1 1	+127 to +109	) forbidden (outside available central counter range)
	0 1 1 0 1 1 0 1	+108 to +1	
	0 1 1 0 1 1 0 0		-32 $\mu$ s (maximum negative value)
	0 0 0 0 0 0 0 1		-0.296 ns
	0 0 0 0 0 0 0 0	0	0 equals reference value
	1 1 1 1 1 1 1 1	-1 to -107	+0.296 $\mu$ s
1 0 0 1 0 1 0 1		+31.7 $\mu$ s (maximum positive value)	
1 0 0 1 0 1 0 0		) forbidden (outside available central counter range)	
1 0 0 0 0 0 0 0	-108 to -128		
BYPS "06"	Input mode select bit: 0 = CVBS mode (chroma trap active) 1 = S-Video mode (chroma trap by-passed)		
	PREF	Use of pre-emphasis (to be used if chrominance trap is active): 0 = pre-filter bypassed; 1 = pre-filter on	
BPSS1 to BPSS0	Aperture bandpass to select different centre frequencies (Figures 23 to 38):		
	BPSS1	BPSS0	centre frequency
	0	0	4.1 MHz
	0	1	3.8 MHz
	1	0	2.6 MHz
1	1	2.9 MHz	

Digital multistandard colour decoder  
with SCART interface (DMSD2-SCART)

SAA7151B

<p>"06" continued BFBY CORI APER1 to APER0</p>	<p>Bandfilter bypass switching: 0 = bandfilter active; 1 = bandfilter bypassed Coring function: 0 = coring off; 1 = ±1 LSB coring Aperture factor (Figures 23 to 38):</p> <table border="1" data-bbox="387 420 704 562"> <thead> <tr> <th>APER1</th> <th>APER0</th> <th>factor</th> </tr> </thead> <tbody> <tr> <td>0</td> <td>0</td> <td>0</td> </tr> <tr> <td>0</td> <td>1</td> <td>0.25</td> </tr> <tr> <td>1</td> <td>0</td> <td>0.5</td> </tr> <tr> <td>1</td> <td>1</td> <td>1</td> </tr> </tbody> </table>	APER1	APER0	factor	0	0	0	0	1	0.25	1	0	0.5	1	1	1																					
APER1	APER0	factor																																			
0	0	0																																			
0	1	0.25																																			
1	0	0.5																																			
1	1	1																																			
<p>HUE7 to HUE0 "07"</p>	<p>Hue control from +178.6° to -180.0°, equals data bytes 7F to 80 (hex); 0° equals 00.</p>																																				
<p>CSTD2 to CSTD0 "08"</p>	<p>Forced colour standard of input signal;</p> <table border="1" data-bbox="387 732 994 999"> <thead> <tr> <th>CSTD2</th> <th>CSTD1</th> <th>CSTD0</th> <th>standard</th> </tr> </thead> <tbody> <tr> <td>0</td> <td>0</td> <td>0</td> <td>PAL-B/G, -H, -I; 50 Hz</td> </tr> <tr> <td>0</td> <td>0</td> <td>1</td> <td>PAL-N; 50 Hz</td> </tr> <tr> <td>0</td> <td>1</td> <td>0</td> <td>SECAM; 50 Hz</td> </tr> <tr> <td>0</td> <td>1</td> <td>1</td> <td>PAL-M; 60 Hz</td> </tr> <tr> <td>1</td> <td>0</td> <td>0</td> <td>PAL 4.43; 60 Hz</td> </tr> <tr> <td>1</td> <td>0</td> <td>1</td> <td>NTSC-M; 60 Hz</td> </tr> <tr> <td>1</td> <td>1</td> <td>0</td> <td>NTSC 4.43; 60 Hz</td> </tr> <tr> <td>1</td> <td>1</td> <td>1</td> <td>black/white</td> </tr> </tbody> </table>	CSTD2	CSTD1	CSTD0	standard	0	0	0	PAL-B/G, -H, -I; 50 Hz	0	0	1	PAL-N; 50 Hz	0	1	0	SECAM; 50 Hz	0	1	1	PAL-M; 60 Hz	1	0	0	PAL 4.43; 60 Hz	1	0	1	NTSC-M; 60 Hz	1	1	0	NTSC 4.43; 60 Hz	1	1	1	black/white
CSTD2	CSTD1	CSTD0	standard																																		
0	0	0	PAL-B/G, -H, -I; 50 Hz																																		
0	0	1	PAL-N; 50 Hz																																		
0	1	0	SECAM; 50 Hz																																		
0	1	1	PAL-M; 60 Hz																																		
1	0	0	PAL 4.43; 60 Hz																																		
1	0	1	NTSC-M; 60 Hz																																		
1	1	0	NTSC 4.43; 60 Hz																																		
1	1	1	black/white																																		
<p>CKTQ4 to CKTQ0</p>	<p>Colour killer threshold QAM (PAL/NTSC):</p> <table border="1" data-bbox="338 1072 1153 1187"> <thead> <tr> <th>CKTQ4</th> <th>CKTQ3</th> <th>CKTQ2</th> <th>CKTQ1</th> <th>CKTQ0</th> <th></th> </tr> </thead> <tbody> <tr> <td>1</td> <td>1</td> <td>1</td> <td>1</td> <td>1</td> <td rowspan="3">approximately -30 to -24 dB -24 dB to -18 dB</td> </tr> <tr> <td>1</td> <td>0</td> <td>0</td> <td>0</td> <td>0</td> </tr> <tr> <td>0</td> <td>0</td> <td>0</td> <td>0</td> <td>0</td> </tr> </tbody> </table>	CKTQ4	CKTQ3	CKTQ2	CKTQ1	CKTQ0		1	1	1	1	1	approximately -30 to -24 dB -24 dB to -18 dB	1	0	0	0	0	0	0	0	0	0														
CKTQ4	CKTQ3	CKTQ2	CKTQ1	CKTQ0																																	
1	1	1	1	1	approximately -30 to -24 dB -24 dB to -18 dB																																
1	0	0	0	0																																	
0	0	0	0	0																																	
<p>OSCE "09"</p>	<p>External UV offset compensation: 0 = disabled; 1 = enabled</p>																																				
<p>LFIS1 to LFIS0</p>	<p>Chrominance gain control (AGC filter):</p> <table border="1" data-bbox="387 1326 1016 1465"> <thead> <tr> <th>LFIS1</th> <th>LFIS0</th> <th>control of loop filter time constant</th> </tr> </thead> <tbody> <tr> <td>0</td> <td>0</td> <td>slow</td> </tr> <tr> <td>0</td> <td>1</td> <td>medium</td> </tr> <tr> <td>1</td> <td>0</td> <td>fast</td> </tr> <tr> <td>1</td> <td>1</td> <td>actual gain, stored (for test purposes only)</td> </tr> </tbody> </table>	LFIS1	LFIS0	control of loop filter time constant	0	0	slow	0	1	medium	1	0	fast	1	1	actual gain, stored (for test purposes only)																					
LFIS1	LFIS0	control of loop filter time constant																																			
0	0	slow																																			
0	1	medium																																			
1	0	fast																																			
1	1	actual gain, stored (for test purposes only)																																			
<p>CKTS4 to CKTS0</p>	<p>Colour killer threshold SECAM as previously described under CKTQ subaddress "08"</p>																																				

Digital multistandard colour decoder  
with SCART interface (DMSD2-SCART)

SAA7151B

PLSE7 to PLSE0 "0A"	PAL switch sensitivity from LOW to HIGH (HIGH means immediate sequence correction), equals FF to 00 (hex), MEDIUM equals 80.																																				
SESE7 to SESE0 "0B"	SECAM switch sensitivity from LOW to HIGH (HIGH means immediate sequence correction), equals FF to 00 (hex), MEDIUM equals 80.																																				
FSAU; GPSI2, and GPSI1 "0C"	<p>Set port outputs (general purpose switching, internal)</p> <table border="1"> <thead> <tr> <th>FSAU</th> <th>GPSI2</th> <th>GPSI1</th> <th>output GPSW2 (pin 25)</th> <th>output GPSW1 (pin 24)</th> </tr> </thead> <tbody> <tr> <td>0</td> <td>0</td> <td>0</td> <td>LOW</td> <td>LOW</td> </tr> <tr> <td>0</td> <td>0</td> <td>1</td> <td>LOW</td> <td>HIGH</td> </tr> <tr> <td>0</td> <td>1</td> <td>0</td> <td>HIGH</td> <td>LOW</td> </tr> <tr> <td>0</td> <td>1</td> <td>1</td> <td>HIGH</td> <td>HIGH</td> </tr> <tr> <td>1</td> <td>X</td> <td>X</td> <td>status bit FSST1 set</td> <td>status bit FSST0 set</td> </tr> </tbody> </table>	FSAU	GPSI2	GPSI1	output GPSW2 (pin 25)	output GPSW1 (pin 24)	0	0	0	LOW	LOW	0	0	1	LOW	HIGH	0	1	0	HIGH	LOW	0	1	1	HIGH	HIGH	1	X	X	status bit FSST1 set	status bit FSST0 set						
FSAU	GPSI2	GPSI1	output GPSW2 (pin 25)	output GPSW1 (pin 24)																																	
0	0	0	LOW	LOW																																	
0	0	1	LOW	HIGH																																	
0	1	0	HIGH	LOW																																	
0	1	1	HIGH	HIGH																																	
1	X	X	status bit FSST1 set	status bit FSST0 set																																	
CGFX	Chrominance gain pre-determination: 0 = gain controlled via loop; 1 = gain set by AMPF-bits																																				
AMPF3 to AMPF0	<p>Chrominance amplification factor</p> <table border="1"> <thead> <tr> <th>AMPF3</th> <th>AMPF2</th> <th>AMPF1</th> <th>AMPF0</th> <th>gain</th> </tr> </thead> <tbody> <tr> <td>0</td> <td>0</td> <td>0</td> <td>0</td> <td>-6 dB</td> </tr> <tr> <td>0</td> <td>1</td> <td>0</td> <td>0</td> <td>0 dB</td> </tr> <tr> <td>0</td> <td>1</td> <td>0</td> <td>1</td> <td>+1.5 dB</td> </tr> <tr> <td>.</td> <td>.</td> <td>.</td> <td>.</td> <td>+3 to +16.5 dB (approximately 1.5 dB steps)</td> </tr> <tr> <td>1</td> <td>1</td> <td>1</td> <td>1</td> <td>+17 dB</td> </tr> </tbody> </table>	AMPF3	AMPF2	AMPF1	AMPF0	gain	0	0	0	0	-6 dB	0	1	0	0	0 dB	0	1	0	1	+1.5 dB	.	.	.	.	+3 to +16.5 dB (approximately 1.5 dB steps)	1	1	1	1	+17 dB						
AMPF3	AMPF2	AMPF1	AMPF0	gain																																	
0	0	0	0	-6 dB																																	
0	1	0	0	0 dB																																	
0	1	0	1	+1.5 dB																																	
.	.	.	.	+3 to +16.5 dB (approximately 1.5 dB steps)																																	
1	1	1	1	+17 dB																																	
COLO "0D"	Colour-on bit: 0 = colour-killer automatically enabled ; 1 = forced colour-on.																																				
CHSB	Chrominance (UV) output code: 0 = two's complement; 1 = straightly binary																																				
GPSW0	General purpose port output (pin 63): 0 = LOW; 1 = HIGH																																				
SUVI	SECAM UV output signal polarity: 0 = U and V positive; 1 = U and V negative																																				
SXCR	SECAM cross-colour reduction: 0 = off; 1 = on																																				
FDSL2 to FDSL0	<p>Fast switching delay adjustment in 37 ns steps:</p> <table border="1"> <thead> <tr> <th>FDSL2</th> <th>FDSL1</th> <th>FDSL0</th> <th>delay</th> </tr> </thead> <tbody> <tr> <td>0</td> <td>0</td> <td>0</td> <td>0</td> </tr> <tr> <td>0</td> <td>0</td> <td>1</td> <td>37 ns</td> </tr> <tr> <td>0</td> <td>1</td> <td>0</td> <td>74 ns</td> </tr> <tr> <td>0</td> <td>1</td> <td>1</td> <td>111 ns</td> </tr> <tr> <td>1</td> <td>0</td> <td>0</td> <td>-148 ns (negative delay)</td> </tr> <tr> <td>1</td> <td>0</td> <td>1</td> <td>-111 ns</td> </tr> <tr> <td>1</td> <td>1</td> <td>0</td> <td>-74 ns</td> </tr> <tr> <td>1</td> <td>1</td> <td>1</td> <td>-37 ns</td> </tr> </tbody> </table>	FDSL2	FDSL1	FDSL0	delay	0	0	0	0	0	0	1	37 ns	0	1	0	74 ns	0	1	1	111 ns	1	0	0	-148 ns (negative delay)	1	0	1	-111 ns	1	1	0	-74 ns	1	1	1	-37 ns
FDSL2	FDSL1	FDSL0	delay																																		
0	0	0	0																																		
0	0	1	37 ns																																		
0	1	0	74 ns																																		
0	1	1	111 ns																																		
1	0	0	-148 ns (negative delay)																																		
1	0	1	-111 ns																																		
1	1	0	-74 ns																																		
1	1	1	-37 ns																																		

# Digital multistandard colour decoder with SCART interface (DMSD2-SCART)

SAA7151B

CCIR "0E"	Set CCIR mode: 0 = digital TV mode (DTV); 1 = CCIR mode				
COFF	Set colour off: 0 = colour on; 1 = colour off				
OEHS	Enable horizontal sync outputs HS and HREF: 0 = output high-impedance; 1 = HS and HREF enabled				
OEVS	Enable vertical sync output VS: 0 = output high-impedance; 1 = VS enabled				
UVSS	Select UV pixel sample: 1 = first pixel after U/V signal has changed; 0 = second pixel (free of crosstalk signals)				
CHRS	S-Video input mode: 0 = chrominance signal from CVBS or CUV input and controlled by BYPS (subaddress 06); 1 = S-Video mode; chrominance signal from CUV input				
CDMO, CDPO	Chrominance delay:				
		CDMO	CDPO		
		0	0	no delay	
		1	X	-37 ns (negative delay)	
		0	1	+37 ns	
AUFD "0F"	Automatical field detection: 0 = field selection by FSEL-bit; 1 = automatical field detection				
FSEL	Field select (AUFD-bit = 0): 0 = 50 Hz (625 lines); 1 = 60 Hz (525 lines)				
HPLL	Horizontal PLL: 0 = PLL closed; 1 = PLL open, horizontal frequency fixed				
SCEN	Sync and clamping pulse enable: 0 = HCL and HSY outputs HIGH (pins 26 and 29); 1 = HCL and HSY outputs active.				
VTRC	VTR/TV mode select: 0 = TV mode (slow time constant); 1 = VTR mode (fast time constant).				
MUIV	MUXC signal inversion: 0 = inverted; 1 = not inverted				
FSIV	Fast switch input signal inversion: 0 = not inverted; 1 = inverted				
WIND	Narrow fast switch window : 0 = off; 1 = on				
ASTD "10"	Automatic standard switching: 0 = off; 1 = on				
OFTS	Select output format: 0 = 4 : 1 : 1 format; 1 = 4 : 2 : 2 format.				
IPBP	External UV signal interpolation filter: 0 = active; 1 = bypassed				
CDVI	Chrominance PLL filter selection for: 0 = VTR or TV source; 1 = fast time constant for FSC-PLL (only for special applications)				
YDEL3 to YDELO	Luminance delay compensation in 37 ns steps:				
	YDEL3	YDEL2	YDEL1	YDELO	delay
	0	0	0	0	) 0 to 259 ns (step 0 to 7)
	0	1	1	1	)
	1	0	0	0	) -296 to -37 ns (negative delay; step -8 to -1)
1	1	1	1	)	

# Digital multistandard colour decoder with SCART interface (DMSD2-SCART)

SAA7151B

CHCV7 to CHCV0 "11"	Chroma gain reference value <table border="1"> <thead> <tr> <th>D7</th> <th>D6</th> <th>D5</th> <th>D4</th> <th>D3</th> <th>D2</th> <th>D1</th> <th>D0</th> <th>gain</th> </tr> </thead> <tbody> <tr> <td>1</td> <td>1</td> <td>1</td> <td>1</td> <td>1</td> <td>1</td> <td>1</td> <td>1</td> <td>maximum gain</td> </tr> <tr> <td>:</td> <td>:</td> <td>:</td> <td>:</td> <td>:</td> <td>:</td> <td>:</td> <td>:</td> <td>to</td> </tr> <tr> <td>1</td> <td>0</td> <td>1</td> <td>1</td> <td>0</td> <td>0</td> <td>1</td> <td>1</td> <td>DTV level</td> </tr> <tr> <td>:</td> <td>:</td> <td>:</td> <td>:</td> <td>:</td> <td>:</td> <td>:</td> <td>:</td> <td>to</td> </tr> <tr> <td>0</td> <td>0</td> <td>1</td> <td>1</td> <td>1</td> <td>1</td> <td>0</td> <td>1</td> <td>CCIR level</td> </tr> <tr> <td>:</td> <td>:</td> <td>:</td> <td>:</td> <td>:</td> <td>:</td> <td>:</td> <td>:</td> <td>to</td> </tr> <tr> <td>0</td> <td>0</td> <td>0</td> <td>0</td> <td>0</td> <td>0</td> <td>0</td> <td>0</td> <td>minimum gain</td> </tr> </tbody> </table> ) default programmed values ) depend on application )	D7	D6	D5	D4	D3	D2	D1	D0	gain	1	1	1	1	1	1	1	1	maximum gain	:	:	:	:	:	:	:	:	to	1	0	1	1	0	0	1	1	DTV level	:	:	:	:	:	:	:	:	to	0	0	1	1	1	1	0	1	CCIR level	:	:	:	:	:	:	:	:	to	0	0	0	0	0	0	0	0	minimum gain
D7	D6	D5	D4	D3	D2	D1	D0	gain																																																																	
1	1	1	1	1	1	1	1	maximum gain																																																																	
:	:	:	:	:	:	:	:	to																																																																	
1	0	1	1	0	0	1	1	DTV level																																																																	
:	:	:	:	:	:	:	:	to																																																																	
0	0	1	1	1	1	0	1	CCIR level																																																																	
:	:	:	:	:	:	:	:	to																																																																	
0	0	0	0	0	0	0	0	minimum gain																																																																	
OEDY "12" OEDC	Enable Y signals on YUV-bus: 0 = output high-impedance; 1 = output active (dependent on FEIN) Enable UV signals on YUV-bus: 0 = output high-impedance; 1 = output active (dependent on FEIN)																																																																								
VNOI1, VNOI0	Vertical noise reduction mode: <table border="1"> <thead> <tr> <th>VNOI1</th> <th>VNOI0</th> <th>mode</th> </tr> </thead> <tbody> <tr> <td>0</td> <td>0</td> <td>normal</td> </tr> <tr> <td>0</td> <td>1</td> <td>searching</td> </tr> <tr> <td>1</td> <td>0</td> <td>free-running</td> </tr> <tr> <td>1</td> <td>1</td> <td>bypassed</td> </tr> </tbody> </table>	VNOI1	VNOI0	mode	0	0	normal	0	1	searching	1	0	free-running	1	1	bypassed																																																									
VNOI1	VNOI0	mode																																																																							
0	0	normal																																																																							
0	1	searching																																																																							
1	0	free-running																																																																							
1	1	bypassed																																																																							
BFON	Bottom flutter compensation switching: 0 = off; 1 = on (controlled by BOFL-bit)																																																																								
BOFL2 to BOFL0	Bottom flutter compensation <table border="1"> <thead> <tr> <th>BOFL2</th> <th>BOFL1</th> <th>BOFL0</th> <th>start at line number</th> </tr> </thead> <tbody> <tr> <td>0</td> <td>0</td> <td>0</td> <td>297 for PAL (247 for NTSC; active to end of field)</td> </tr> <tr> <td>0</td> <td>0</td> <td>1</td> <td>298 for PAL (248 for NTSC; active to end of field)</td> </tr> <tr> <td>.</td> <td>.</td> <td>.</td> <td>.</td> </tr> <tr> <td>1</td> <td>1</td> <td>0</td> <td>303 for PAL (253 for NTSC; active to end of field)</td> </tr> <tr> <td>1</td> <td>1</td> <td>1</td> <td>304 for PAL (254 for NTSC; active to end of field)</td> </tr> </tbody> </table> <p>The bottom flutter circuit is able to compensate for horizontal phase jump of up to ±16 µs.</p>	BOFL2	BOFL1	BOFL0	start at line number	0	0	0	297 for PAL (247 for NTSC; active to end of field)	0	0	1	298 for PAL (248 for NTSC; active to end of field)	.	.	.	.	1	1	0	303 for PAL (253 for NTSC; active to end of field)	1	1	1	304 for PAL (254 for NTSC; active to end of field)																																																
BOFL2	BOFL1	BOFL0	start at line number																																																																						
0	0	0	297 for PAL (247 for NTSC; active to end of field)																																																																						
0	0	1	298 for PAL (248 for NTSC; active to end of field)																																																																						
.	.	.	.																																																																						
1	1	0	303 for PAL (253 for NTSC; active to end of field)																																																																						
1	1	1	304 for PAL (254 for NTSC; active to end of field)																																																																						
Note: The bottom flutter gate is active at <ul style="list-style-type: none"> <li>- HPLL is locked</li> <li>- HPLL in VTR mode</li> <li>- the vertical noise limiter (VNL) is in the VTR mode</li> <li>- gating is switched by BFON-bit = 1 (subaddress 12)</li> </ul>																																																																									
<table border="1"> <thead> <tr> <th>Gate 2</th> <th>Gate 1</th> <th>HPLL function</th> </tr> </thead> <tbody> <tr> <td>0</td> <td>0</td> <td>normal</td> </tr> <tr> <td>1</td> <td>0</td> <td>disabled</td> </tr> <tr> <td>0</td> <td>1</td> <td>double speed</td> </tr> <tr> <td>1</td> <td>1</td> <td>unused</td> </tr> </tbody> </table>	Gate 2	Gate 1	HPLL function	0	0	normal	1	0	disabled	0	1	double speed	1	1	unused	<p>vertical pulse</p> <p>gate 2</p> <p>programmable by BOFL(2-0)</p> <p>000 111</p> <p>gate 1</p>																																																									
Gate 2	Gate 1	HPLL function																																																																							
0	0	normal																																																																							
1	0	disabled																																																																							
0	1	double speed																																																																							
1	1	unused																																																																							

# Digital multistandard colour decoder with SCART interface (DMSD2-SCART)

SAA7151B

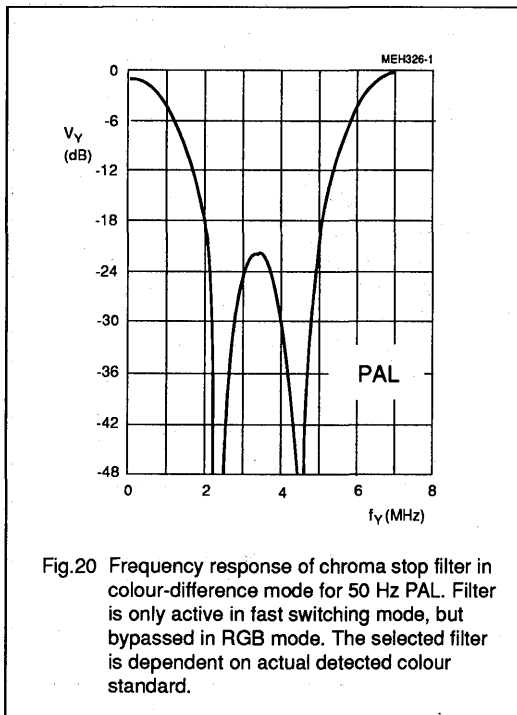

Fig.20 Frequency response of chroma stop filter in colour-difference mode for 50 Hz PAL. Filter is only active in fast switching mode, but bypassed in RGB mode. The selected filter is dependent on actual detected colour standard.

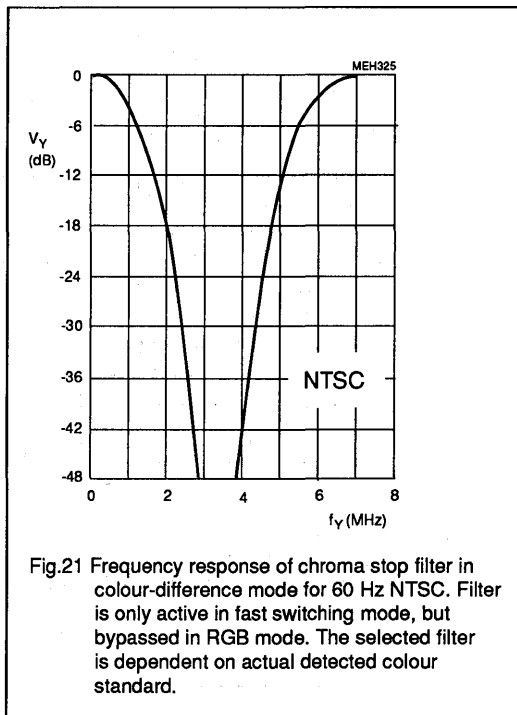

Fig.21 Frequency response of chroma stop filter in colour-difference mode for 60 Hz NTSC. Filter is only active in fast switching mode, but bypassed in RGB mode. The selected filter is dependent on actual detected colour standard.

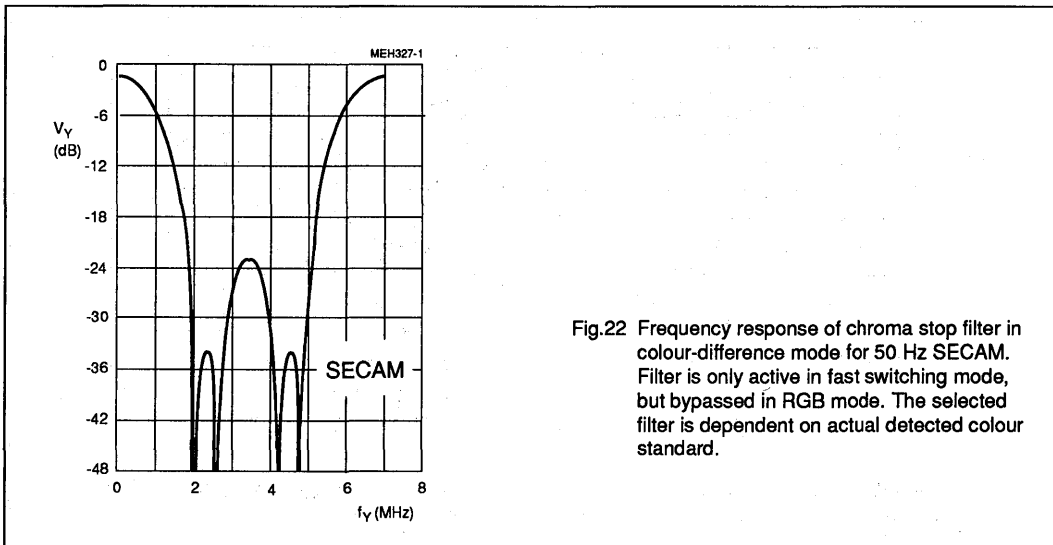
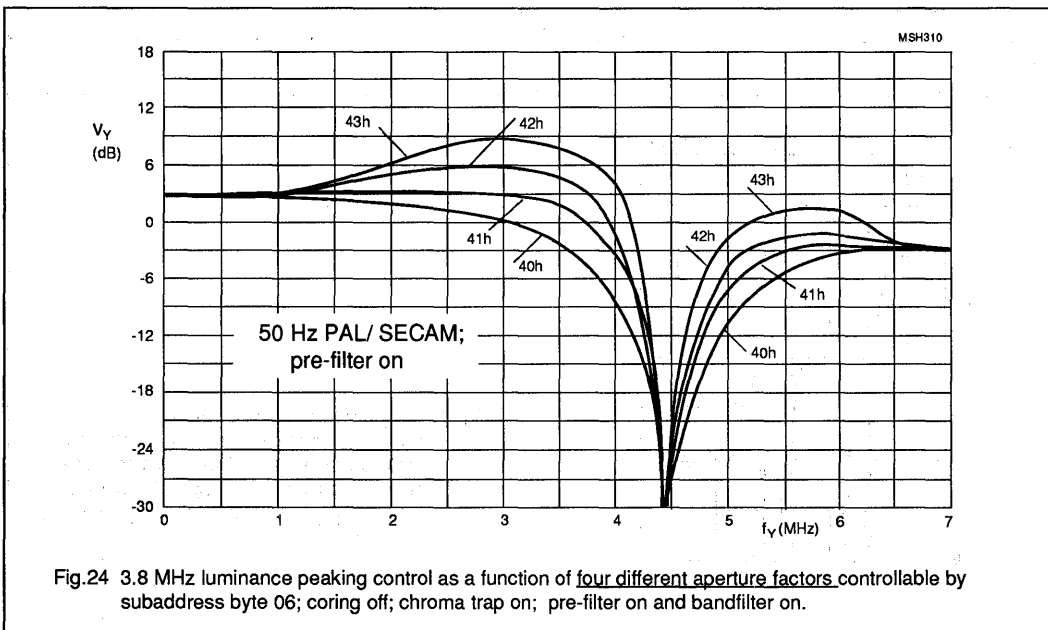
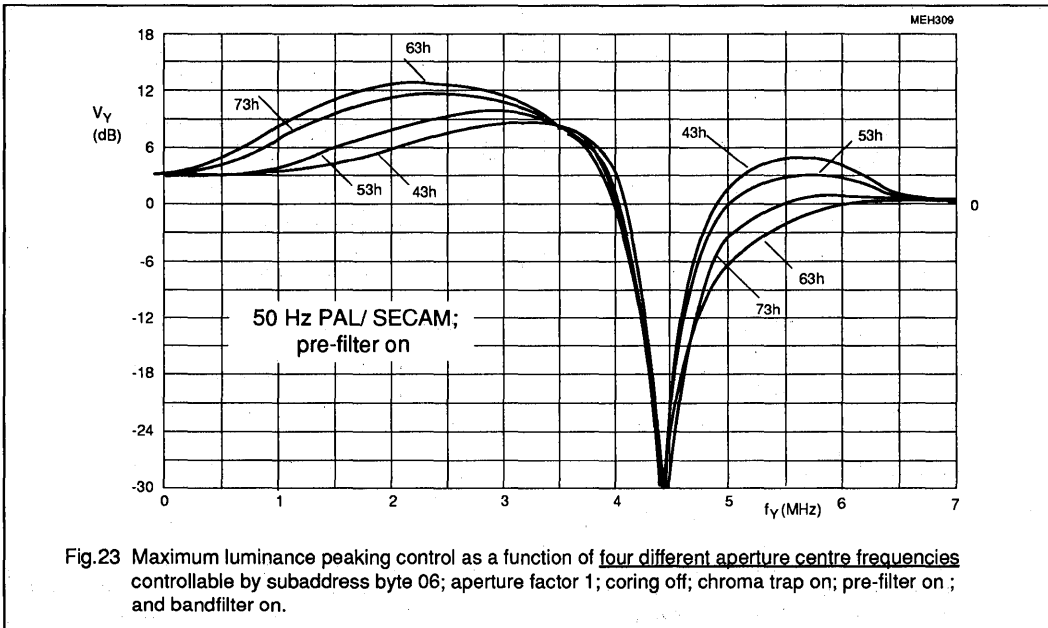

Fig.22 Frequency response of chroma stop filter in colour-difference mode for 50 Hz SECAM. Filter is only active in fast switching mode, but bypassed in RGB mode. The selected filter is dependent on actual detected colour standard.

Digital multistandard colour decoder with SCART interface (DMSD2-SCART)

SAA7151B





Digital multistandard colour decoder  
with SCART interface (DMSD2-SCART)

SAA7151B

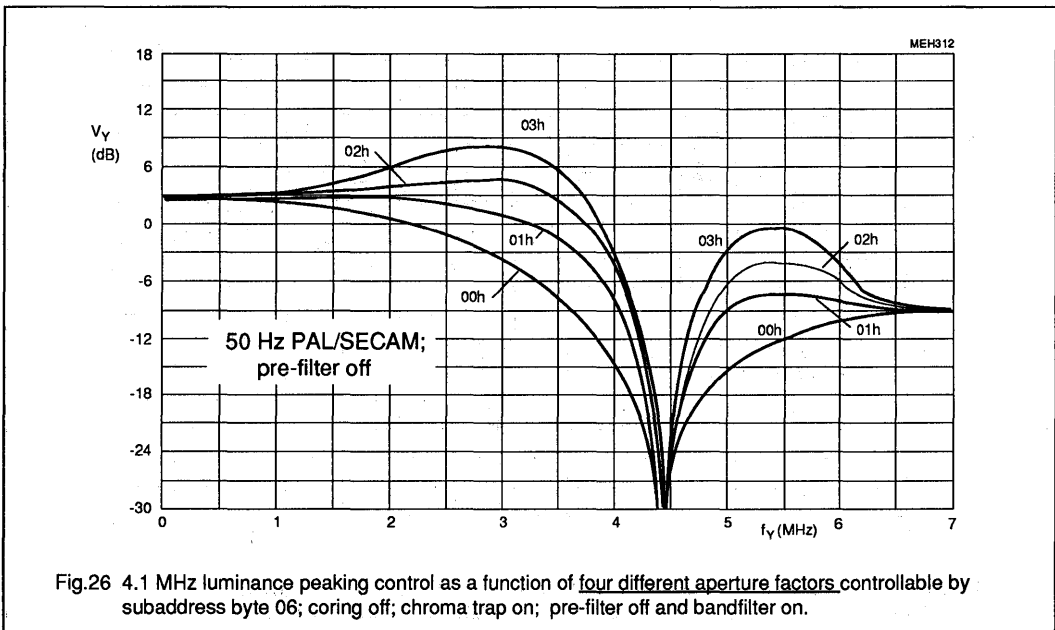
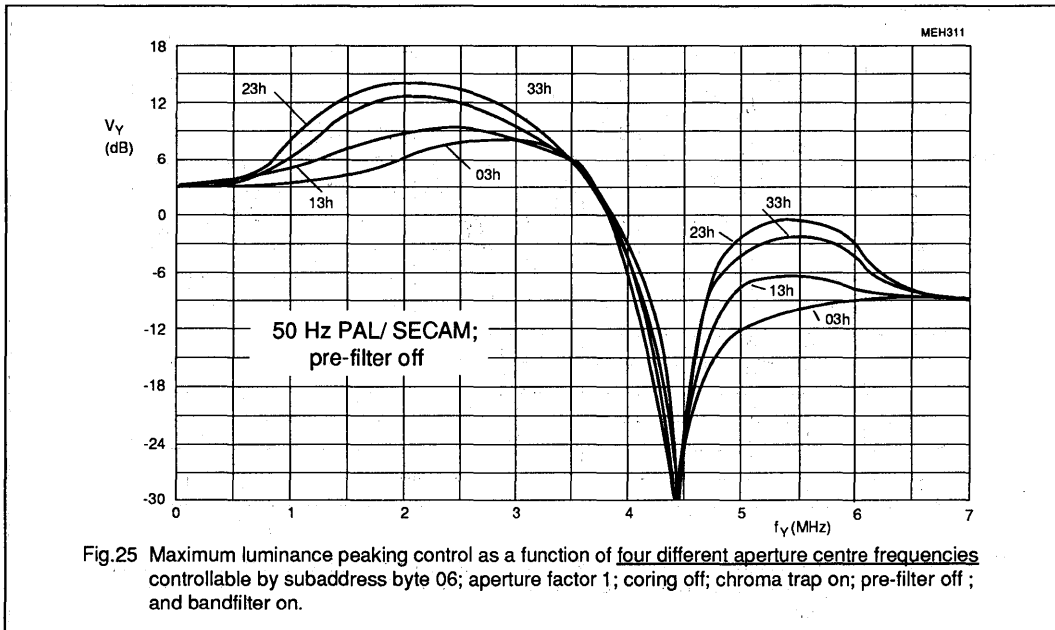

Digital multistandard colour decoder  
with SCART interface (DMSD2-SCART)

SAA7151B

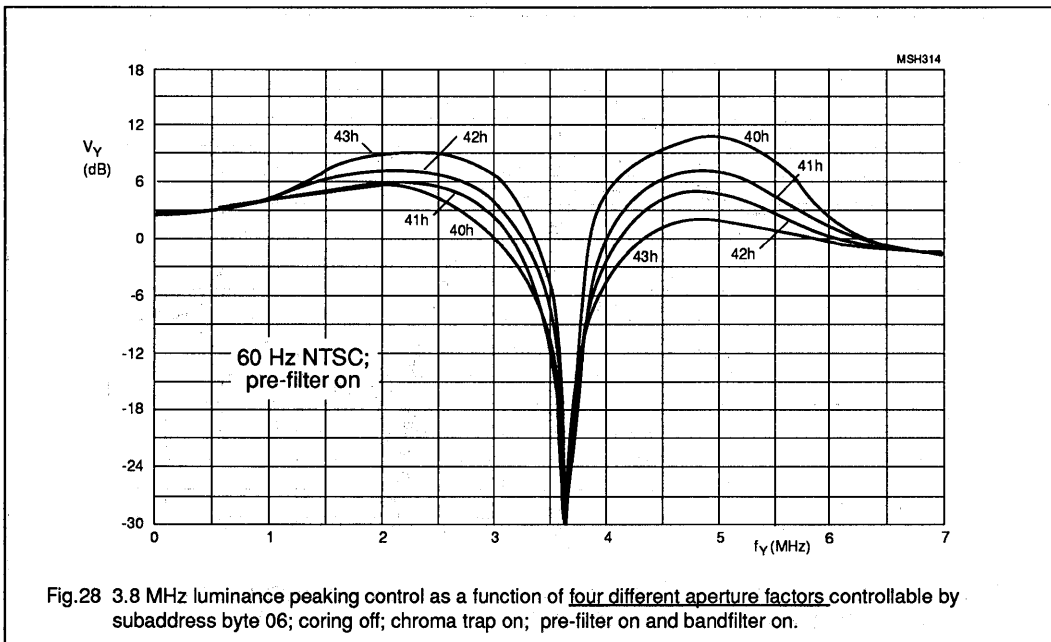
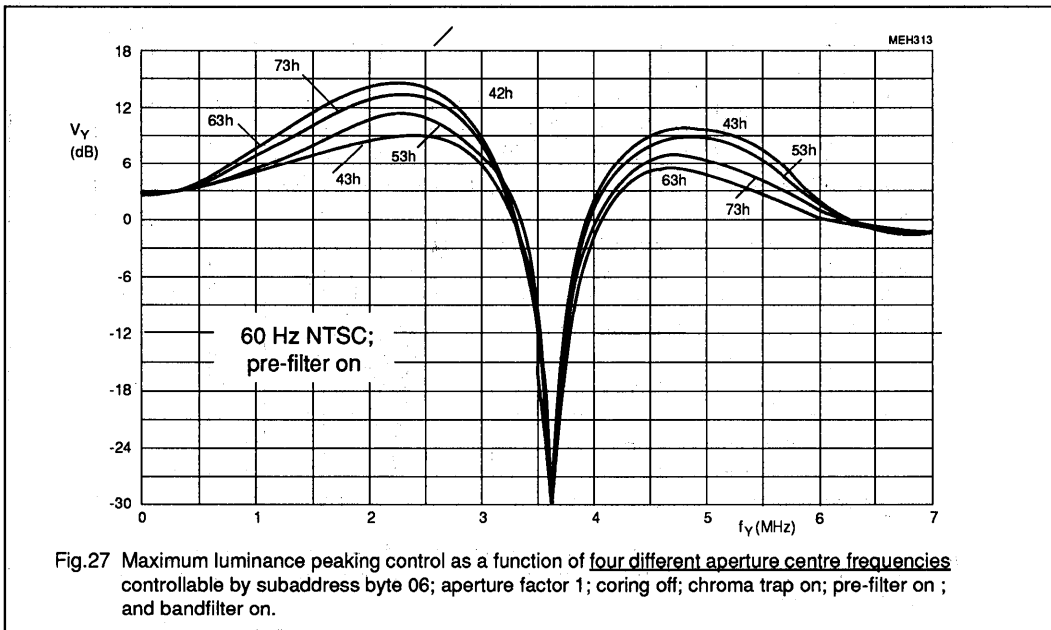

Digital multistandard colour decoder  
with SCART interface (DMSD2-SCART)

SAA7151B

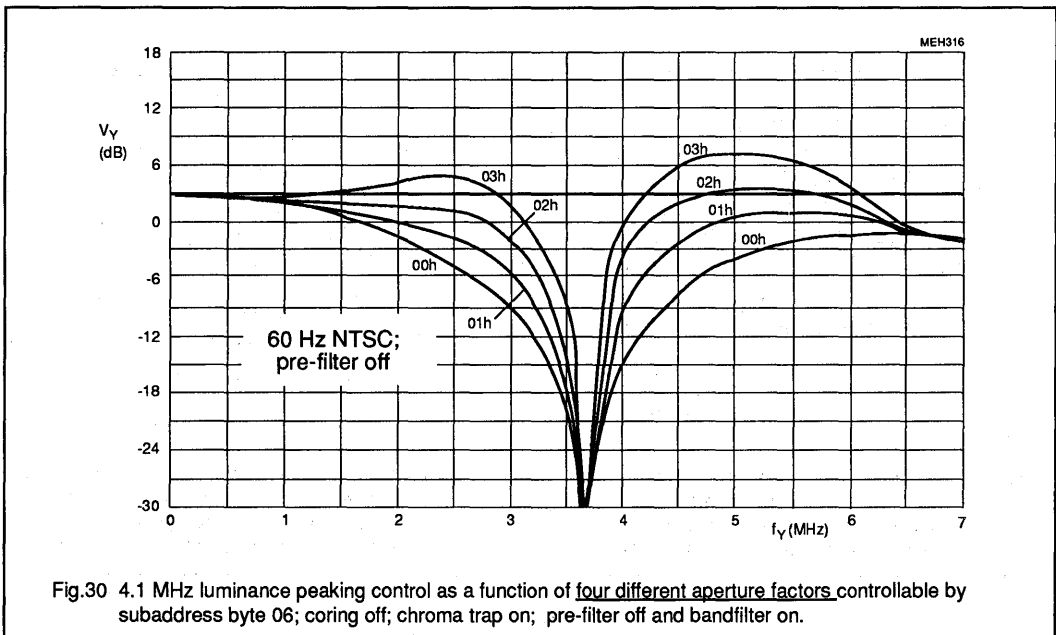
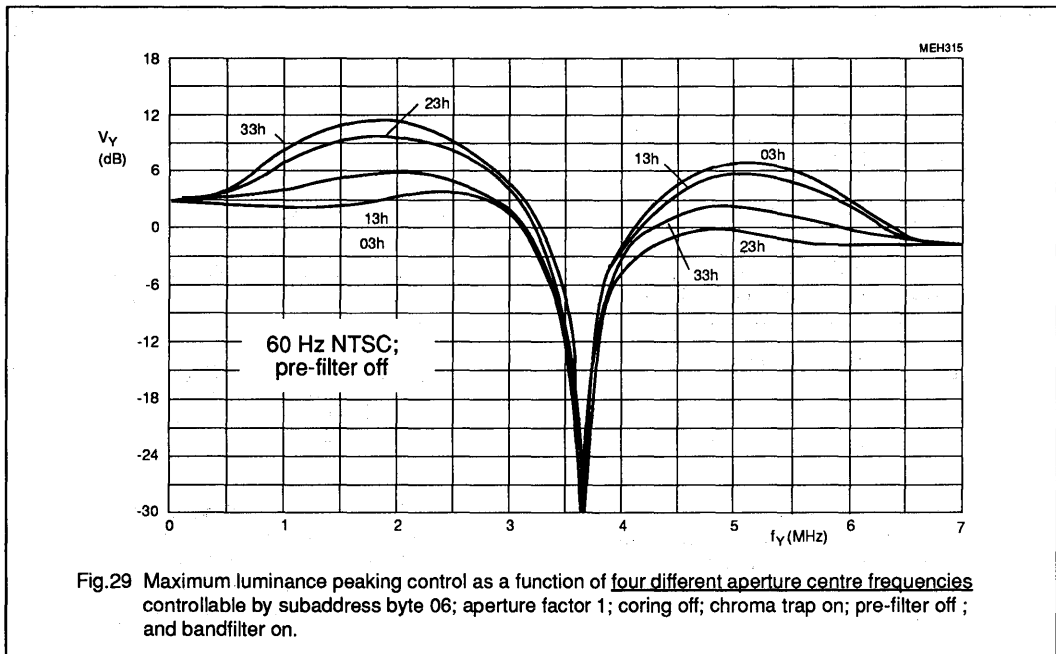

Digital multistandard colour decoder  
with SCART interface (DMSD2-SCART)

SAA7151B

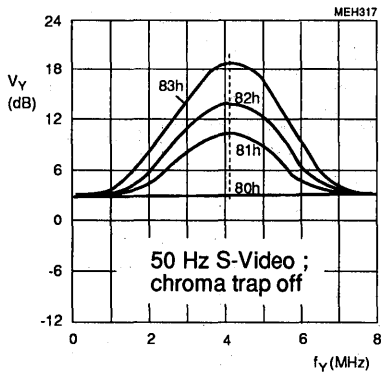

Fig.31 4.1 MHz luminance peaking control control as a function of four different aperture factors controllable by subaddress byte 06; pre-filter off; coring off and bandpass filter on.

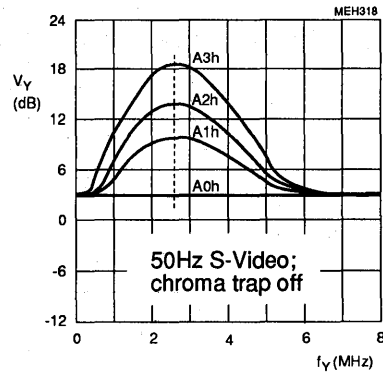

Fig.32 2.6 MHz luminance peaking control control as a function of four different aperture factors controllable by subaddress byte 06; pre-filter off; coring off and bandpass filter on.

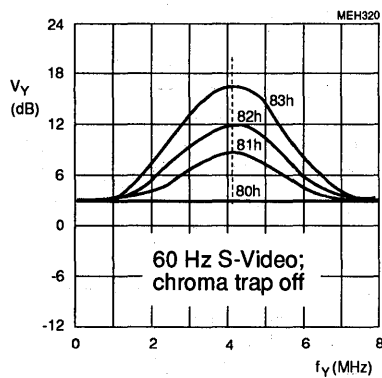

Fig.33 4.1 MHz luminance peaking control control as a function of four different aperture factors controllable by subaddress byte 06; pre-filter off; coring off and bandpass filter on.

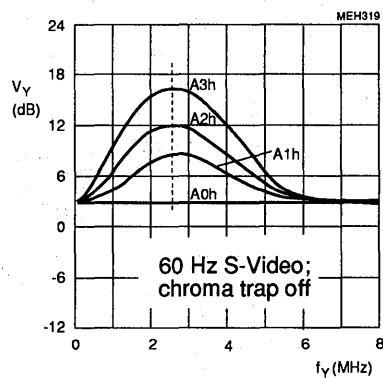
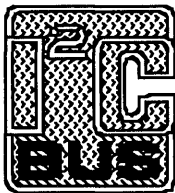
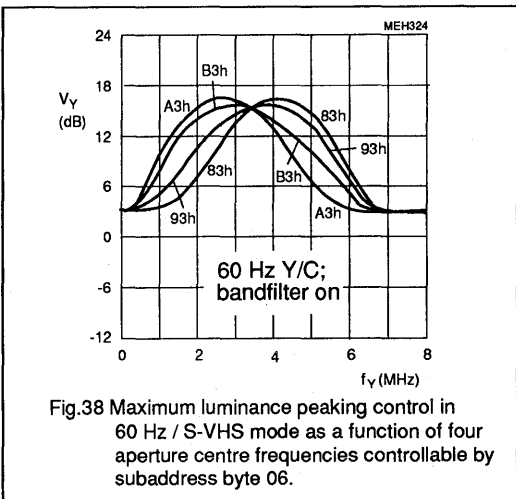
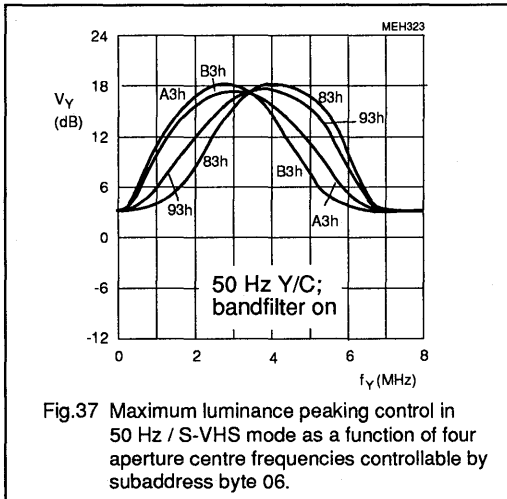
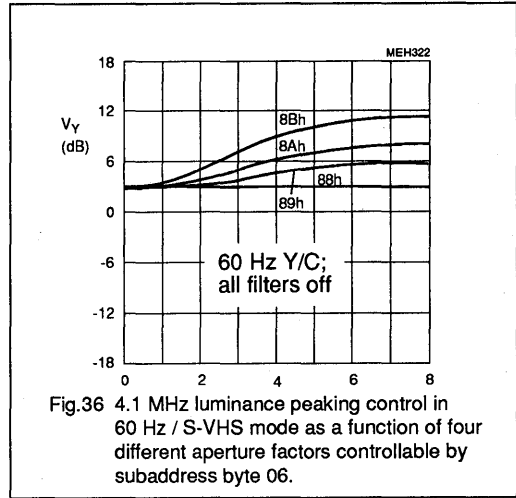
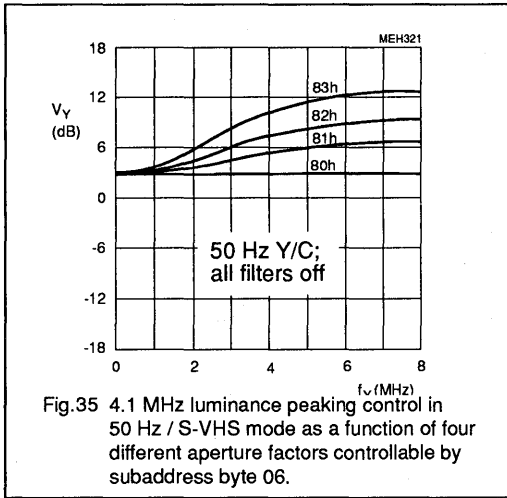

Fig.34 2.6 MHz luminance peaking control control as a function of four different aperture factors controllable by subaddress byte 06; pre-filter off; coring off and bandpass filter on.

Digital multistandard colour decoder  
with SCART interface (DMSD2-SCART)

SAA7151B



Purchase of Philips' I<sup>2</sup>C components conveys a license under the Philips' I<sup>2</sup>C patent to use the components in the I<sup>2</sup>C-system provided the system conforms to the I<sup>2</sup>C specifications defined by Philips.

# Digital multistandard colour decoder with SCART interface (DMSD2-SCART)

SAA7151B

## 11. PROGRAMMING EXAMPLE

Coefficients to set operation for application circuits Figures 17, 18 and 19. Values recommended for PAL CVBS input signal and 4:2:2 CCIR output signal (all numbers of the Table 6 are hex values).

**Table 7** Recommended default values (note 1)

SUBADDRESS	BIT NAME	FUNCTION	VALUE (HEX)
00	IDEL(7-0)	increment delay	4D
01	HSYB(7-0)	horizontal sync HSY begin	3D
02	HSYS(7-0)	horizontal sync HSY stop	0D
03	HCLB(7-0)	horizontal clamping HCL begin	F3
04	HCLS(7-0)	horizontal clamping HCL stop	C6
05	HPhi(7-0)	horizontal sync after PHI1	FB
06	BYPS, PREF, BPSS(1-0) BFBY, COR1, APER(1-0)	luminance bandwidth control:	02 (note 2)
07	HUEC(7-0)	hue control (0 degree)	00
08	CSTD(2-0), CKTQ(4-0)	miscellaneous controls #1	09
09	OSCE, LFIS(1-0), CKTS(4-0)	miscellaneous controls #2	C0
0A	PLSE(7-0)	PAL switch sensitivity	4D
0B	SESE(7-0)	SECAM switch sensitivity	40
0C	FSAU, GPSI(2-1), CGFX, AMPF(3-0)	miscellaneous controls #3	80
0D	COLO, CHSB, GPSWO, SUVI, SXCR, FSDL(2-0)	miscellaneous controls #4	60
0E	CCIR, COEF, OEHS, OEVS UVSS, CHRS, CDMO, CDPO	miscellaneous controls #5	B4
0F	AUFD, FSEL, HPLL, SCEN, VTRC, MUIV, FSIV, WIND	miscellaneous controls #6	9F
10	ASTD, OFTS, IPBP, CDVI, YDEL(3-0)	miscellaneous controls #7	C0
11	CHCV(7-0)	nominal chrominance gain	4F
12	OEDY, OEDC, VNOI(1-0), BFON, BOFL(2-0)	miscellaneous controls #8	C2

### Notes to Table 7

- 1 Slave address is 8A (hex) at IICSA = LOW or 8E (hex) at IICSA = HIGH.
- 2 Dependent on applications (Figures 23 to 38)

## Digital video comb filter (DCF)

SAA7152

## 1. FEATURES

- Comb filter circuit for luminance and chrominance separation
- Applicable for standards
  - PAL B/G, M and N
  - PAL 4.43 (525 lines; 60 Hz)
  - NTSC M and N
  - NTSC 4.43 (50 and 60 Hz)
- Luminance and chrominance bypasses with short delay in case of no filtering
- Line-locked system clock; CCIR-compatible
- I<sup>2</sup>C-bus controlled

## 2. GENERAL DESCRIPTION

The CMOS digital comb filter circuit is located between video analog-to-digital converters and the video multistandard decoder SAA7151B (not applicable for SAA7191B). The two-dimensional filtering is only appropriate for standard signals from a source with constant phase relationship between subcarrier signal and horizontal frequency. The comb-filter has to be switched off for VTR signals and for separate VBS and C signals. In VCR and S-Video operation the luminance

low-pass and the chrominance bandpass parts can still be used for noise reduction purposes.

The processing delay is 21 x LL27 clocks in active mode or 3 x LL27 in short delay bypass mode (BYPS = 1).

## 3. QUICK REFERENCE DATA

SYMBOL	PARAMETER	MIN.	TYP.	MAX.	UNIT
V <sub>DD</sub>	supply voltage (pins 11, 34, 44)	4.5	5.0	5.5	V
I <sub>P</sub>	total supply current	-	85	180	mA
V <sub>i</sub>	input levels	TTL-compatible			
V <sub>o</sub>	output levels	TTL-compatible			
LL27	typical system clock frequency	-	27	-	MHz
T <sub>amb</sub>	operating ambient temperature range	0	-	70	°C

## 4. ORDERING INFORMATION

EXTENDED TYPE NUMBER	PACKAGE			
	PINS	PIN POSITION	MATERIAL	CODE
SAA7152	44	PLCC	plastic	SOT187

# Digital video comb filter (DCF)

SAA7152

## 5. BLOCK DIAGRAM

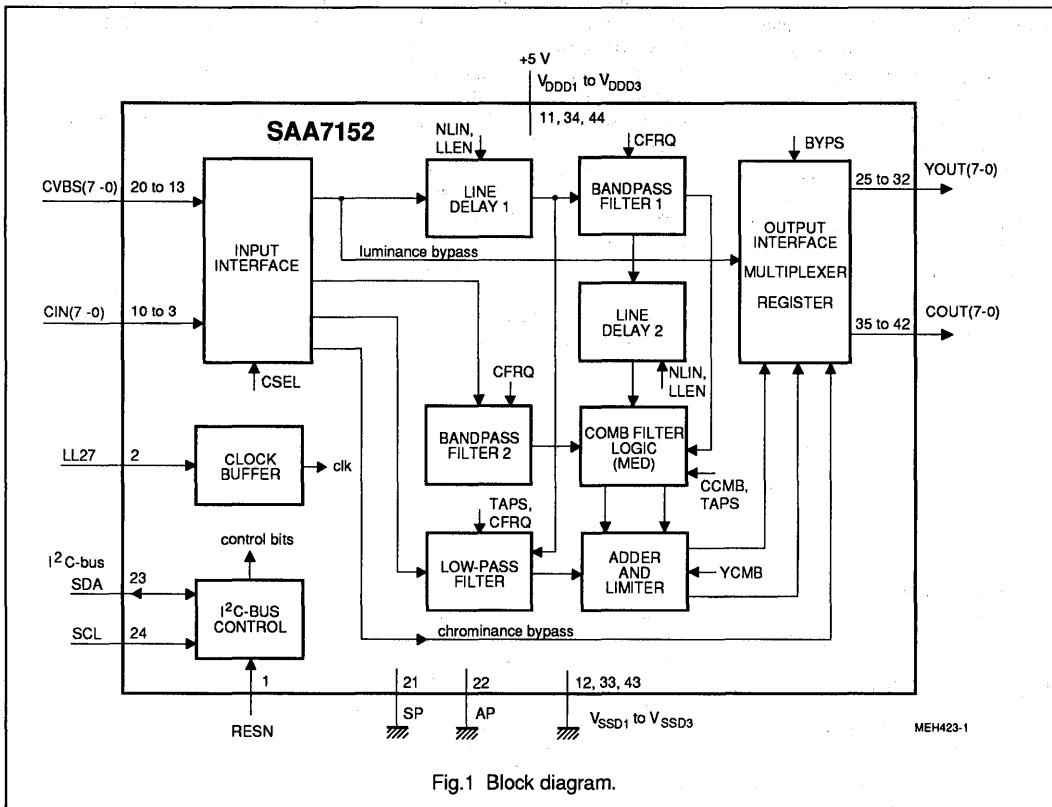

Fig.1 Block diagram.

## 6. PINNING

SYMBOL	PIN	DESCRIPTION
RESN	1	reset input; active-LOW
LL27	2	line-locked system clock input (27 MHz)
CIN0	3	chrominance input data bits CIN0 to CIN7
CIN1	4	
CIN2	5	
CIN3	6	
CIN4	7	
CIN5	8	
CIN6	9	
CIN7	10	



## Digital video comb filter (DCF)

SAA7152

SYMBOL	PIN	DESCRIPTION
V <sub>DD1</sub>	11	+5 V supply input 1
V <sub>SS1</sub>	12	ground 1 (0 V)
CVBS0	13	CVBS input data bits 0 to 7
CVBS1	14	
CVBS2	15	
CVBS3	16	
CVBS4	17	
CVBS5	18	
CVBS6	19	
CVBS7	20	
SP	21	connected to ground (shift pin for testing)
AP	22	connected to ground (action pin for testing)
SDA	23	I <sup>2</sup> C-bus data line
SCL	24	I <sup>2</sup> C-bus clock line
YOUT7	25	luminance (Y) output data bits 7 to 0
YOUT6	26	
YOUT5	27	
YOUT4	28	
YOUT3	29	
YOUT2	30	
YOUT1	31	
YOUT0	32	
V <sub>SS2</sub>	33	ground 2 (0 V)
V <sub>DD2</sub>	34	+5 V supply input 2
COOUT7	35	chrominance (C) output data bits 7 to 0
COOUT6	36	
COOUT5	37	
COOUT4	38	
COOUT3	39	
COOUT2	40	
COOUT1	41	
COOUT0	42	
V <sub>SS3</sub>	43	ground 3 (0 V)
V <sub>DD3</sub>	44	+5 V supply input 3

# Digital video comb filter (DCF)

# SAA7152

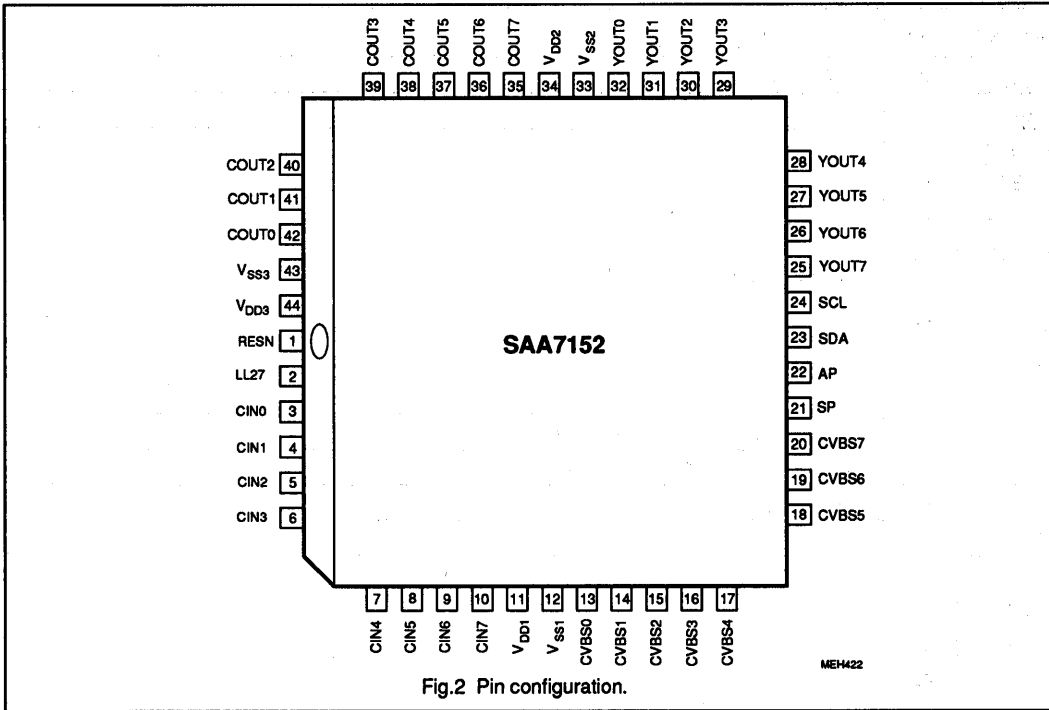

Fig.2 Pin configuration.

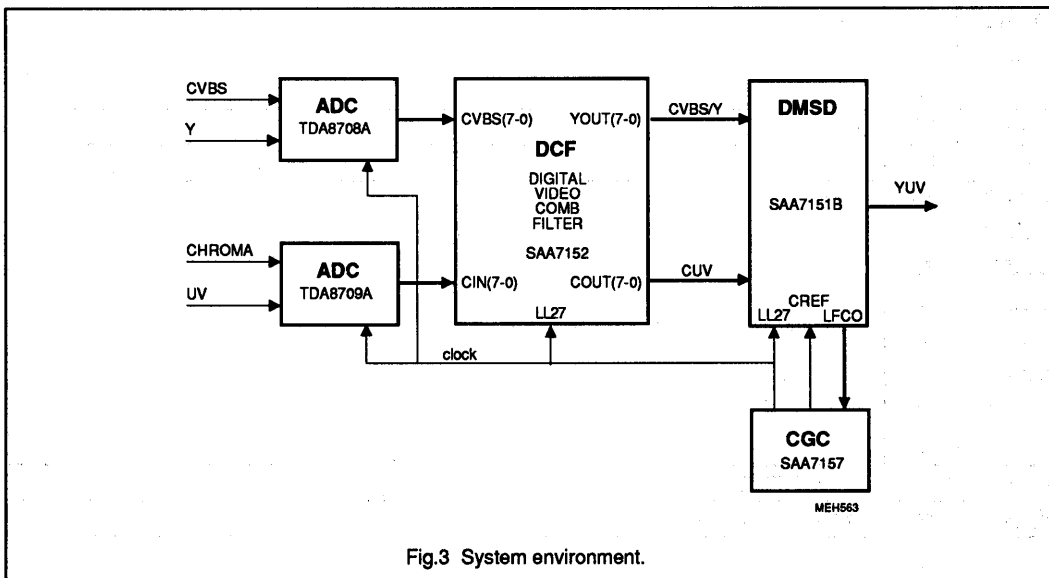

Fig.3 System environment.

## Digital video comb filter (DCF)

SAA7152

7. I<sup>2</sup>C-BUS FORMAT

S	SLAVE ADDRESS	A	SUBADDRESS	A	DATA0	A	DATA <sub>n</sub>	A	P
---	---------------	---	------------	---	-------	---	-------------------	---	---

S	=	start condition
SLAVE ADDRESS	=	1011 0010 (B2 h)
A	=	acknowledge, generated by the slave
SUBADDRESS*	=	subaddress byte (Table 1)
DATA	=	data byte (Table 1)
P	=	stop condition
X	=	read/write control bit
		X = 0, order to write (the circuit is slave receiver)
		X = 1, order to read (the circuit is slave transmitter)

\* If more than 1 byte DATA are transmitted, then auto-increment of the subaddress is performed.

**Table 1** I<sup>2</sup>C-bus; subaddress and data bytes for writing (after X = 0 in address byte)

FUNCTION	SUBADDRESS	DATA							
		D7	D6	D5	D4	D3	D2	D1	D0
Controls	00	BYPS	CSEL	CCMB	YCMB	TAPS	CFRQ	NLIN	LLEN

Function of the bits of Table 1:	
BYPS	Select bypass with a short delay; all other functions are disabled: 0 = no bypass; 1 = comb filter bypassed (delay is 3 LLC)
CSEL	Input mode select: 0 = CVBS selected; 1 = Y/C selected
CCMB	Select comb filtering: 0 = chrominance is bandpassed; 1 = chrominance is comb-filtered
YCMB	Enable chrominance subtraction from CVBS signal: 0 = disabled, CVBS/Y signal is only low-passed 1 = enabled (chrominance trap or comb filtering)
TAPS	Selects tap for switching Y and C to adder: 0 = for bandpass/low-pass combination 1 = for comb filter active
CFRQ	Select centre frequency and matching factor of chrominance filter: 0 = 4.43 MHz; 1 = 3.58 MHz
NLIN	Select delay (number of lines): 0 = 4-line comb filter for standard PAL 1 = 2-line comb filter for standard NTSC
LLEN	Selects the number of clocks for each line delay: 0 = 1728 clocks (625 lines); 50 Hz 1 = 1716 clocks (525 lines); 60 Hz

# Digital video comb filter (DCF)

SAA7152

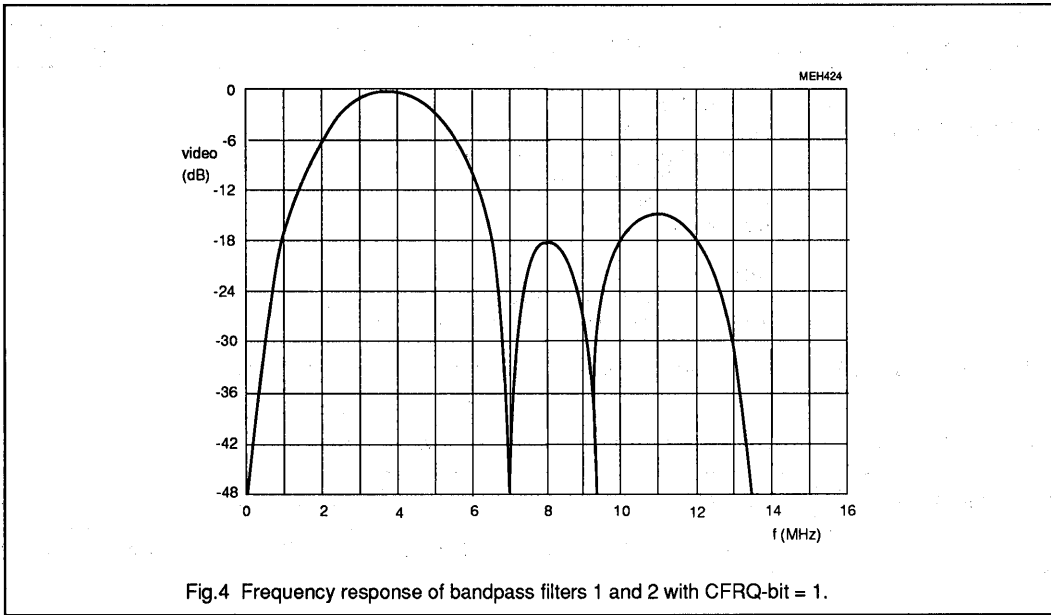

Fig.4 Frequency response of bandpass filters 1 and 2 with CFRQ-bit = 1.

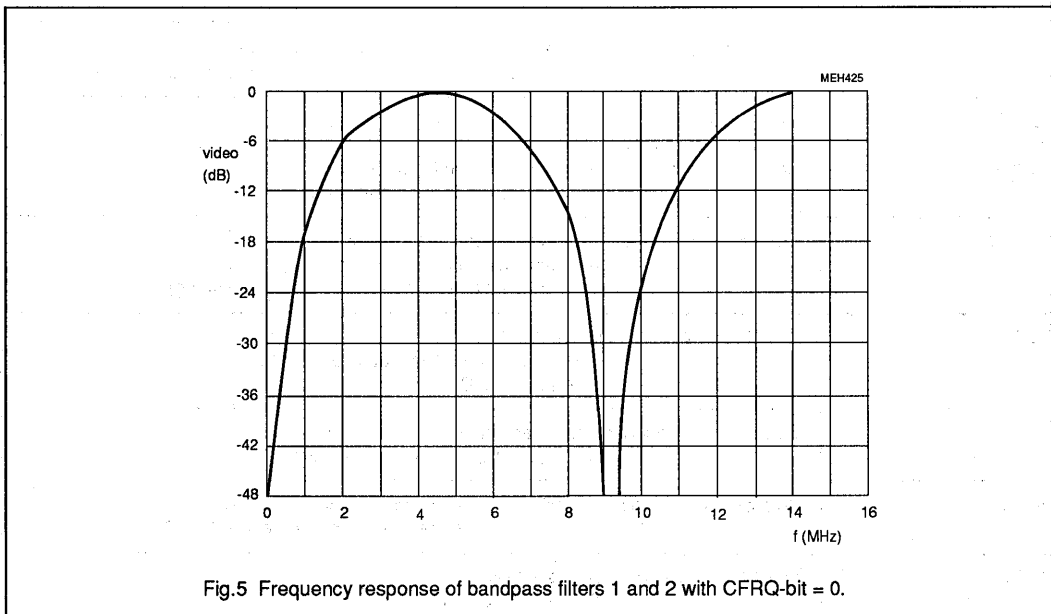

Fig.5 Frequency response of bandpass filters 1 and 2 with CFRQ-bit = 0.

# Digital video comb filter (DCF)

# SAA7152

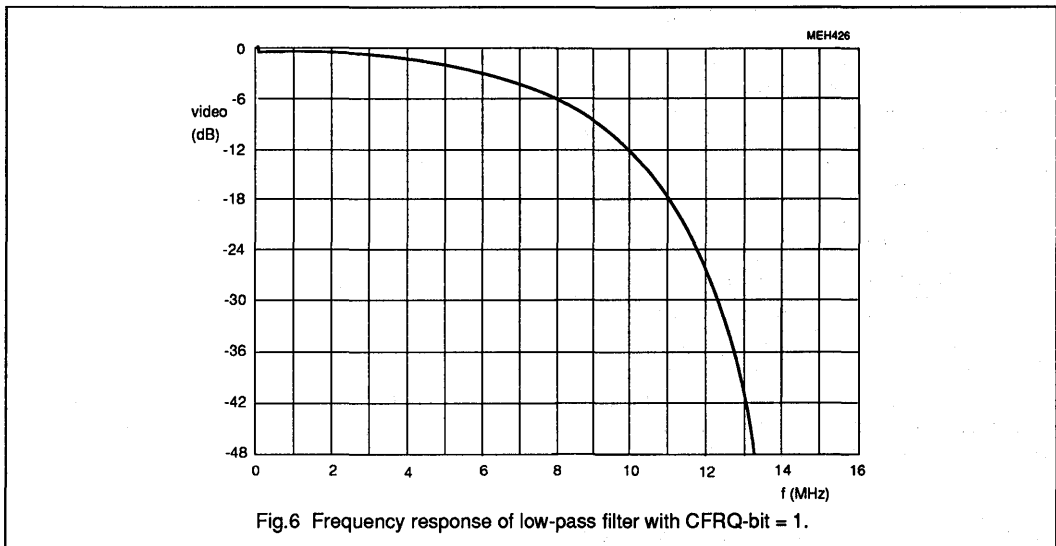

Fig.6 Frequency response of low-pass filter with CFRQ-bit = 1.

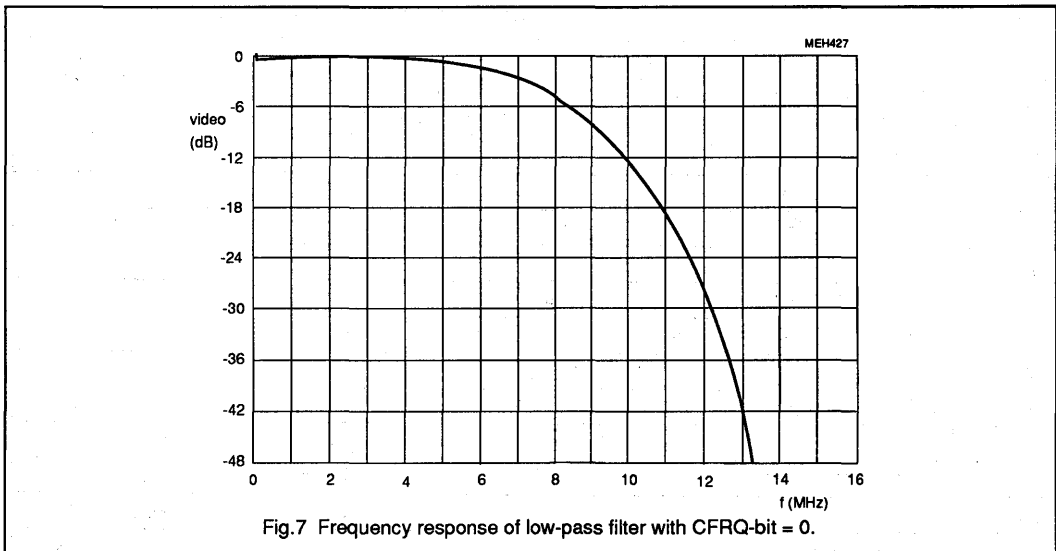

Fig.7 Frequency response of low-pass filter with CFRQ-bit = 0.



Purchase of Philips' I<sup>2</sup>C components conveys a license under the Philips' I<sup>2</sup>C patent to use the components in the I<sup>2</sup>C-system provided the system conforms to the I<sup>2</sup>C specifications defined by Philips.

## Digital video comb filter (DCF)

SAA7152

## 8. LIMITING VALUES

In accordance with the Absolute Maximum Rating System (IEC 134).

SYMBOL	PARAMETER	MIN.	MAX.	UNIT
$V_{DD}$	supply voltage (pins 11, 34, 44)	-0.5	7.0	V
$V_I$	voltage on all inputs	-0.5	$V_{DD}+0.5$	V
$V_O$	voltage on all outputs ( $I_{O\ max} = 20\ mA$ )	-0.5	$V_{DD}+0.5$	V
$P_{tot}$	total power dissipation	-	1.0	W
$T_{stg}$	storage temperature range	-65	150	°C
$T_{amb}$	operating ambient temperature range	0	70	°C
$V_{ESD}$	electrostatic handling* for all pins	-	±2000	V

\* Equivalent to discharging a 100 pF capacitor through a 1.5 kΩ series resistor; inputs and outputs are protected against electrostatic discharge in normal handling. Normal precautions appropriate to handle MOS devices is recommended ("Handling MOS Devices").

## 9. CHARACTERISTICS

 $V_{DD1}$  to  $V_{DD3} = 5\ V$ ;  $T_{amb} = 0$  to  $70\ ^\circ C$  and measurements taken in Fig.1 unless otherwise specified.

SYMBOL	PARAMETER	CONDITIONS	MIN.	TYP.	MAX.	UNIT
$V_{DD}$	supply voltage range (pins 11, 34, 44)		4.5	5	5.5	V
$I_{DD}$	total supply current (pins 11, 34, 44)	$V_{DD} = 5\ V$ ; inputs LOW; outputs not connected	-	85	180	mA
<b>I<sup>2</sup>C-bus, SDA and SCL (pins 23 and 24)</b>						
$V_{IL}$	input voltage LOW		-0.5	-	1.5	V
$V_{IH}$	input voltage HIGH		3	-	$V_{DD}+0.5$	V
$I_{23, 24}$	input current		-	-	±10	μA
$I_{ACK}$	output current on pin 23	acknowledge	3	-	-	mA
$V_{OL}$	output voltage at acknowledge	$I_{23} = 3\ mA$	-	-	0.4	V
<b>Data and clock inputs (pins 2 to 10 and pins 13 to 20)</b>						
$V_{IL}$	LL27 input voltage (pin 2)	LOW	-0.5	-	0.6	V
$V_{IH}$		HIGH	2.4	-	$V_{DD}+0.5$	V
$V_{IL}$	other input voltages	LOW	-0.5	-	0.8	V
$V_{IH}$		HIGH	2.0	-	$V_{DD}+0.5$	V
$I_{leak}$	input leakage current		-	-	10	μA
$C_I$	input capacitance	data inputs	-	-	8	pF
		clock inputs	-	-	10	pF
$t_{SU,DAT}$	input data set-up time	Fig.8	11	-	-	ns
$t_{HD,DAT}$	input data hold time		3	-	-	ns

# Digital video comb filter (DCF)

SAA7152

SYMBOL	PARAMETER	CONDITIONS	MIN.	TYP.	MAX.	UNIT
<b>Data outputs (pins 25 to 32 and pins 35 to 42)</b>						
$V_{OL}$	output voltage LOW		0	-	0.6	V
$V_{OH}$	output voltage HIGH		2.4	-	$V_{DD}$	V
$C_L$	load capacitor		8	-	25	pF
<b>Timing of data outputs</b>			Fig.8			
$t_{OH}$	output signal hold time from positive edge of LL27	$C_L = 8 \text{ pF}$	3	-	-	ns
$t_{OD}$	output delay from positive edge of LL27	$C_L = 25 \text{ pF}$	-	-	32	ns
<b>Line locked clock input LL27 (pin 2)</b>			Fig.8			
$t_{LL27}$	cycle time	note 1	35	-	39	ns
$t_p$	duty factor	$t_{LL27H} / t_{LL27}$	40	50	60	%
$t_r$	rise time		-	-	5	ns
$t_f$	fall time		-	-	6	ns

**Note to the characteristics**

1.  $t_{SU}$ ,  $t_{HD}$ ,  $t_{OH}$  and  $t_{OD}$  include  $t_r$  and  $t_f$ .

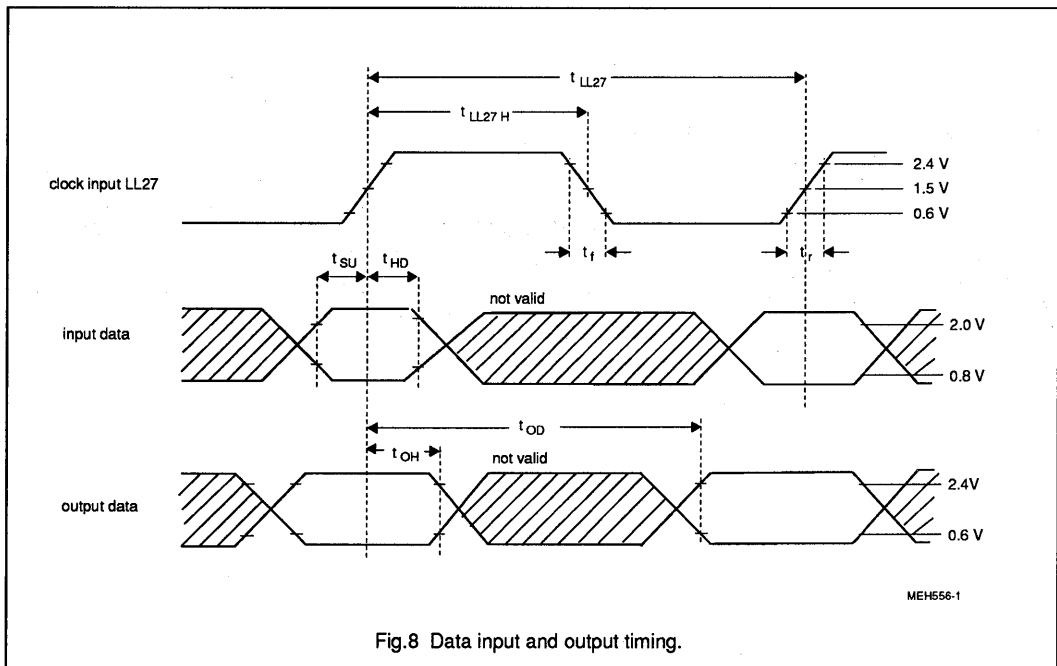

Fig.8 Data input and output timing.

# Clock signal generator circuit for digital TV systems (SCGC)

SAA7157

## FEATURES

- Clock generation suitable for digital TV systems (line-locked)
- PLL frequency multiplier to generate 4 times of input frequency
- Dividers to generate clocks LL1.5A, LL1.5B, LL3A and LL3B (4th and 2nd multiples of input frequency)
- PLL mode or VCO mode selectable
- Reset control and power fail detection
- Suitable for applications with feature box and picture memory

## QUICK REFERENCE DATA

SYMBOL	PARAMETER	MIN.	TYP.	MAX.	UNIT
$V_{DDA}$	analog supply voltage (pin 5)	4.5	5.0	5.5	V
$V_{DDD}$	digital supply voltage (pins 8, 17)	4.5	5.0	5.5	V
$I_{DDA}$	analog supply current	3	-	9	mA
$I_{DDD}$	digital supply current	10	-	60	mA
$V_{LFCO}$	LFCO input voltage (peak-to-peak value)	1	-	$V_{DDA}$	V
$f_i$	input frequency range	6.0	-	7.25	MHz
$V_I$	input voltage LOW input voltage HIGH	0 2.0	- -	0.8 $V_{DDD}$	V V
$V_O$	output voltage LOW output voltage HIGH	0 2.6	- -	0.6 $V_{DDD}$	V V
$T_{amb}$	operating ambient temperature range	0	-	70	°C

## GENERAL DESCRIPTION

The SAA7157 generates all clock signals required for a digital TV system suitable for the SAA715x family and the SAA7199B (DENC). The circuit operates in either the phase-locked loop mode (PLL) or voltage controlled oscillator mode (VCO).

## ORDERING INFORMATION

EXTENDED TYPE NUMBER	PACKAGE			
	PINS	PIN POSITION	MATERIAL	CODE
SAA7157	20	DIL	plastic	SOT146
SAA7157T	20	mini-pack (SO20)	plastic	SOT163A



# Clock signal generator circuit for digital TV systems (SCGC)

## SAA7157

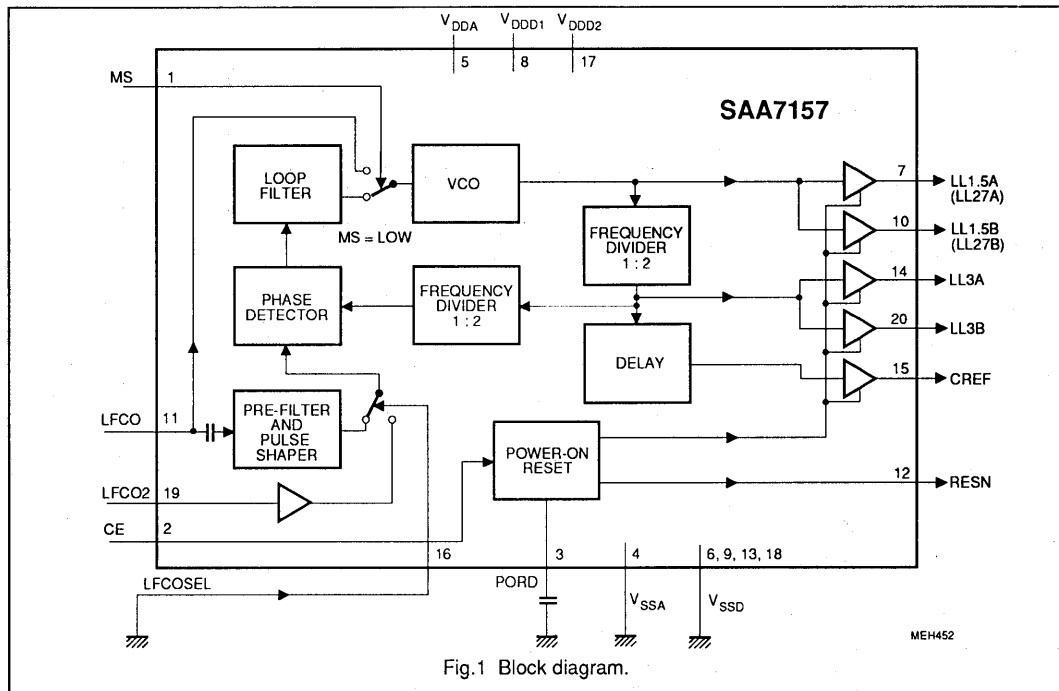

### FUNCTION DESCRIPTION

The SAA7157 generates all clock signals required for a digital TV system suitable for the SAA715x family consisting of an 8-bit analog-to-digital converter (ADC8), digital video multistandard decoder (DMSD2) and video enhancement and D/A processor circuit (VEDA). Optional extras (feature box, video memory etc.) can be driven via external buffers, advantageous for a digital TV system based on display standard conversion concepts.

The 6.75 MHz input signal LFCO (triangular waveform) coming from the DMSD or LFCO2 is multiplied to 27 MHz by the PLL (including phase detector, loop filter, VCO and frequency divider) and output on LL1.5A (pin7) and LL1.5B (pin 10). The 13.5 MHz frequencies are generated by dividers using ratio of 1:2 and are output on LL3A (pin 14) and LL3B (pin 20).

The rectangular output signals have 50 % duty factor. Outputs with equal frequency may be connected together externally. The clock outputs go HIGH during power-on reset (and chip enable) to ensure that no output clock signals are available before the PLL has locked-on.

#### Mode select MS

The LFCO input signal is directly connected to the VCO at MS = HIGH. The circuit operates as an oscillator and frequency divider. This function is not tested.

#### Source select LFCOSEL

Line frequency control signal (LFCO) is selected by LFCOSEL input.

LFCOSEL = LOW:

signal from LFCO (pin 11) is selected.

LFCOSEL = HIGH:

signal from LFCO2 (pin 19) is selected.

This function is not tested.

#### Chip enable CE

The buffer outputs are enabled and

RESN is set to HIGH by CE = HIGH (Fig.4). CE = LOW sets the clock outputs HIGH and RESN output LOW.

#### CREF output

TV2 digital clock reference output signal. Clock qualifier signal to TV system with 2 times of LFCO or LFCO2 frequency.

#### Power-on reset

Power-on reset is activated at power-on, when the supply voltage decreases below 3.5 V (Fig.4) or when chip enable is done. The indicator output RESN is LOW for a time determined by capacitor on pin 3. The RESN signal can be applied to reset other circuits of this digital TV system.

The LFCO or LFCO2 input signals have to be applied before RESN becomes HIGH.

# Clock signal generator circuit for digital TV systems (SCGC)

SAA7157

## PINNING

SYMBOL	PIN	DESCRIPTION
MS	1	mode select input (LOW = PLL mode)
CE	2	chip enable /reset (HIGH = outputs enabled)
PORD	3	power-on reset delay, dependent on external capacitor
V <sub>SSA</sub>	4	analog ground (0 V)
V <sub>DDA</sub>	5	analog supply voltage (+5 V)
V <sub>SSD1</sub>	6	digital ground 1 (0 V)
LL1.5A	7	line-locked clock output signal 1.5A (4 times $f_{LFCO}$ )
V <sub>DD1</sub>	8	digital supply voltage 1 (+5 V)
V <sub>SSD2</sub>	9	digital ground 2 (0 V)
LL1.5B	10	line-locked clock output signal 1.5B (4 times $f_{LFCO}$ )
LFCO	11	line-locked frequency control input signal 1
RESN	12	reset output (active-LOW, Fig.4)
V <sub>SSD3</sub>	13	digital ground 3 (0 V)
LL3A	14	line-locked clock output signal 3A (2 times $f_{LFCO}$ )
CREF	15	clock reference output, qualifier signal (2 times $f_{LFCO}$ )
LFCOSEL	16	LFCO source select (LOW = LFCO selected)*
V <sub>DD2</sub>	17	digital supply voltage 2 (+5 V)
V <sub>SSD4</sub>	18	digital ground 4 (0 V)
LFCO2	19	line-locked frequency control input signal 2*
LL3B	20	line-locked clock output signal 3B (2 times $f_{LFCO}$ )

## PIN CONFIGURATION

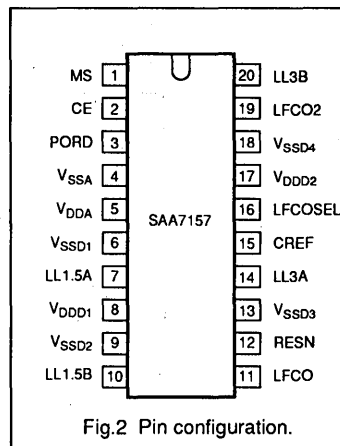

## LIMITING VALUES

In accordance with the Absolute Maximum Rating System (IEC 134); ground pins as well as supply pins together connected.

SYMBOL	PARAMETER	MIN.	MAX.	UNIT
V <sub>DDA</sub>	analog supply voltage (pin 5)	-0.5	7.0	V
V <sub>DD</sub>	digital supply voltage (pins 8 and 17)	-0.5	7.0	V
V <sub>diff GND</sub>	difference voltage V <sub>DDA</sub> - V <sub>DD</sub>	-	±100	mV
V <sub>O</sub>	output voltage (I <sub>OM</sub> = 20 mA)	-0.5	V <sub>DD</sub>	V
P <sub>tot</sub>	total power dissipation (DIL20)	0	1.1	W
T <sub>stg</sub>	storage temperature range	-65	150	°C
T <sub>amb</sub>	operating ambient temperature range	0	70	°C
V <sub>ESD</sub>	electrostatic handling** for all pins	-	tbef	V

\* MS and LFCO2 functions are not tested. LFCO2 is a multiple of horizontal frequency.

\*\* Inputs and outputs are protected against electrostatic discharge in normal handling. However, to be totally safe, it is recommended to take normal handling precautions appropriate to "Handling MOS devices".

# Clock signal generator circuit for digital TV systems (SCGC)

SAA7157

**CHARACTERISTICS**

$V_{DDA} = 4.5$  to  $5.5$  V;  $V_{DDD} = 4.5$  to  $5.5$  V;  $f_{LFCO} = 6.0$  to  $7.25$  MHz and  $T_{amb} = 0$  to  $70$  °C unless otherwise specified.

SYMBOL	PARAMETER	CONDITIONS	MIN.	TYP.	MAX.	UNIT
$V_{DDA}$	analog supply voltage (pin 5)		4.5	5.0	5.5	V
$V_{DDD}$	digital supply voltage (pins 8 and 17)		4.5	5.0	5.5	V
$I_{DDA}$	analog supply current (pin 5)		3	-	9	mA
$I_{DDD}$	digital supply current ( $I_g + I_{17}$ )	note 1	10	-	60	mA
$V_{reset}$	power-on reset threshold voltage	Fig.4	-	3.5	-	V
<b>Input LFCO (pin 11)</b>						
$V_{11}$	DC input voltage		0	-	$V_{DDA}$	V
$V_i$	input signal (peak-to-peak value)		1	-	$V_{DDA}$	V
$f_{LFCO}$	input frequency range		6.0	-	7.25	MHz
$C_{11}$	input capacitance		-	-	10	pF
<b>Inputs MS, CE, LFCOSEL and LFCO2 (pins 1, 2, 16 and 19); note 3</b>						
$V_{iL}$	input voltage LOW		0	-	0.8	V
$V_{iH}$	input voltage HIGH		2.0	-	$V_{DDD}$	V
$f_{LFCO2}$	input frequency range for LFCO2		6.0	-	7.25	MHz
$I_{Li}$	input leakage current	LFCOSEL	50	-	150	$\mu$ A
		others	-	-	10	$\mu$ A
$C_i$	input capacitance		-	-	5	pF
<b>Output RESN (pin 12)</b>						
$V_{OL}$	output voltage LOW	$I_{OL} = 2$ mA	0	-	0.4	V
$V_{OH}$	output voltage HIGH	$I_{OH} = -0.5$ mA	2.4	-	$V_{DDD}$	V
$t_d$	RESN delay time	$C_3 = 0.1$ $\mu$ F; Fig.4	20	-	200	ms
<b>Output CREF (pin 15)</b>						
$V_{OL}$	output voltage LOW	$I_{OL} = 2$ mA	0	-	0.6	V
$V_{OH}$	output voltage HIGH	$I_{OH} = -0.5$ mA	2.4	-	$V_{DDD}$	V
$f_{CREF}$	output frequency CREF	Fig.3	-	$2 f_{LFCO(2)}$		MHz
$C_L$	output load capacitance		15	-	40	pF
$t_{SU}$	set-up time	Fig.3; note 1	12	-	-	ns
$t_{HD}$	hold time	Fig.3; note 1	4	-	-	ns
<b>Output signals LL1.5A, LL1.5B, LL3A and LL3B (pins 7, 10, 14, and 20); note 3</b>						
$V_{OL}$	output voltage LOW	$I_{OL} = 2$ mA	0	-	0.6	V
$V_{OH}$	output voltage HIGH	$I_{OH} = -0.5$ mA	2.6	-	$V_{DDD}$	V
$t_{comp}$	composite rise time	Fig.3; notes 1 and 2	-	-	8	ns

# Clock signal generator circuit for digital TV systems (SCGC)

SAA7157

SYMBOL	PARAMETER	CONDITIONS	MIN.	TYP.	MAX.	UNIT
$f_{LL}$	output frequency LL1.5A	Fig.3	-	$4 f_{LFCO(2)}$		MHz
	output frequency LL1.5B		-	$4 f_{LFCO(2)}$		MHz
	output frequency LL3A		-	$2 f_{LFCO(2)}$		MHz
	output frequency LL3B		-	$2 f_{LFCO(2)}$		MHz
$t_r, t_f$	rise and fall times	note 1; Fig.3	-	-	5	ns
$t_{LL}$	duty factor LL1.5A, LL1.5B, LL3A and LL3B (mean values)	note 1; Fig.3; at 1.5 V level	43	50	57	%

**Notes to the characteristics**

- $f_{LFCO} = 7.0$  MHz and output load 40 pF (Fig.3).  $V_{SSA}$  and  $V_{SSD}$  short connected together.
- $t_{comp}$  is the rise time from LOW of all clocks to HIGH of all clocks (Fig.3) including rise time, skew and jitter components. Measurements taken between 0.6 V and 2.6 V. Skew between two LLx clocks will not deviate more than  $\pm 2$  ns if output loads are matched within 20 %.
- MS and LFCO2 functions not tested.

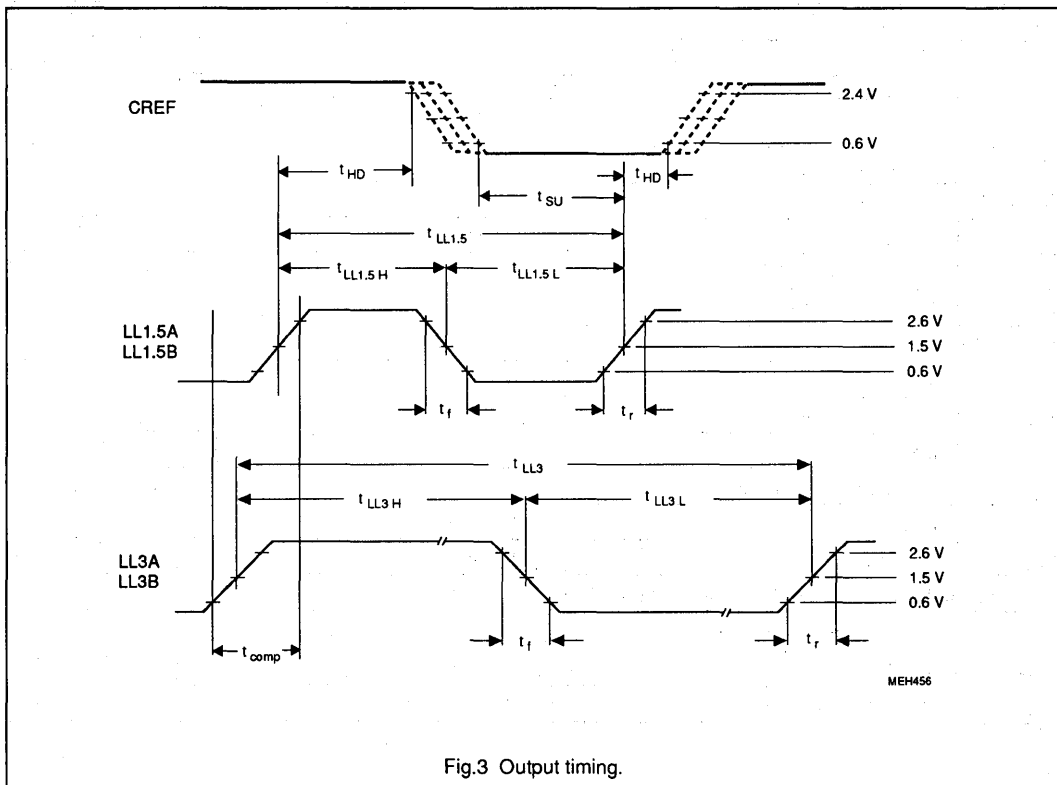

Fig.3 Output timing.

# Clock signal generator circuit for digital TV systems (SCGC)

SAA7157

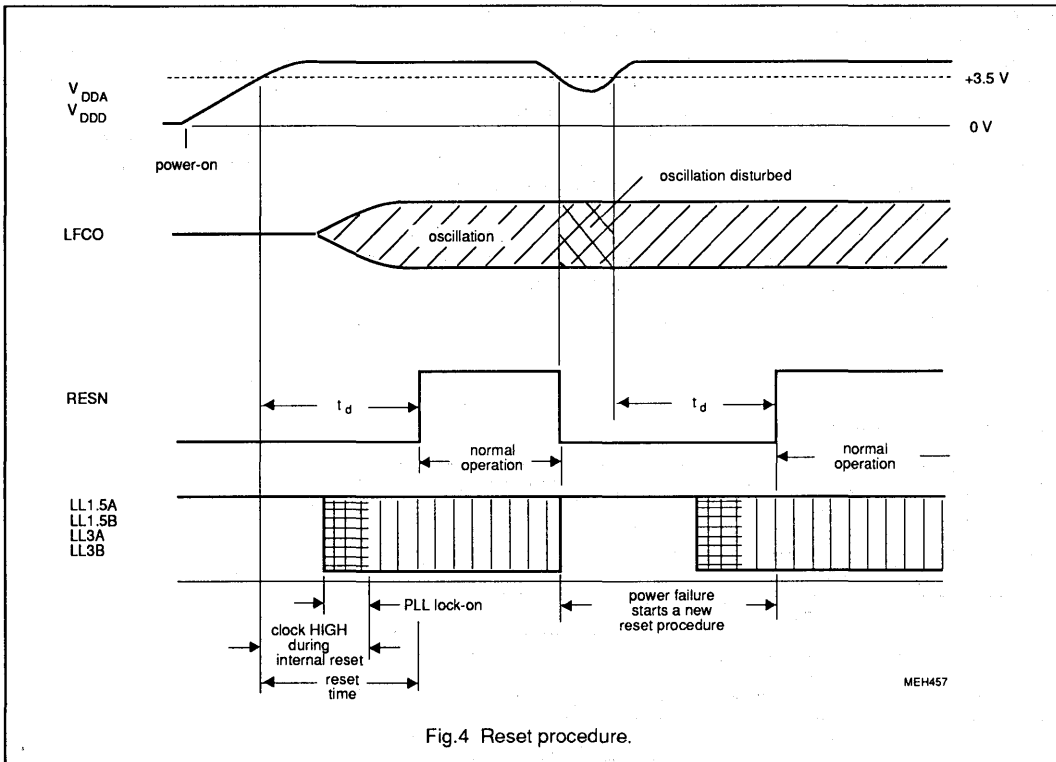

Fig.4 Reset procedure.

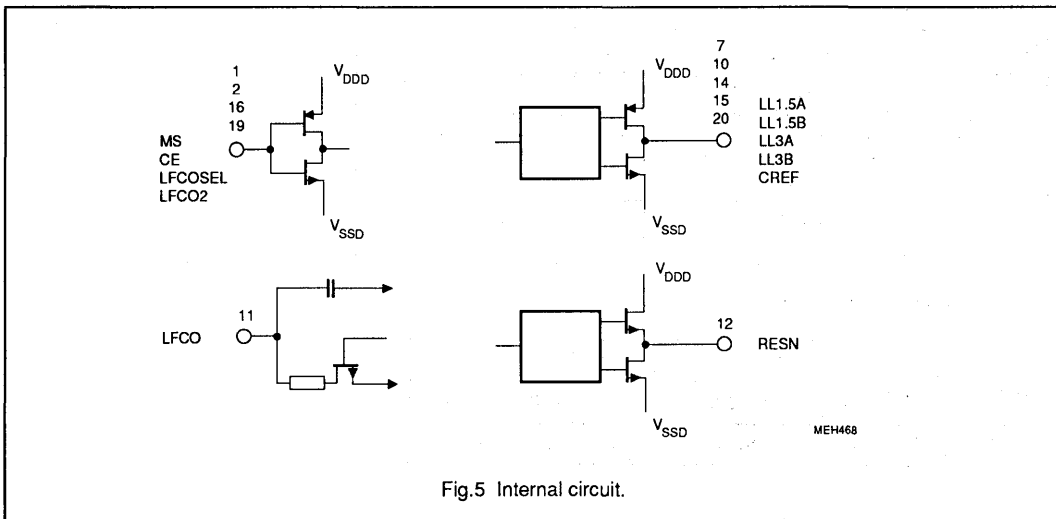

Fig.5 Internal circuit.

## Video enhancement and D/A processor (VEDA3)

SAA7164

## 1. FEATURES

- CMOS circuit to enhance video data and to convert luminance and colour-difference signals from digital-to-analog
- 16-bit parallel input for 4:1:1 and 4:2:2 YUV data
- Data clock input LLC (line-locked clock) for a data rate up to 45 MHz
- 8-bit luminance and 8-bit multiplexed colour-difference formats (optional 7-bit formats)
- MC input to support various clock and pixel rates
- Formatter for YUV input data; 4:2:2 format, 4:1:1 format and filter characteristics selectable
- HREF input to determine the active line (number of pixels)
- Controllable peaking of luminance signal
- Coring stage with controllable threshold to eliminate noise in luminance signal
- Interpolation filter suitable for both formats to increase the data rate in chrominance path
- Polarity of colour-difference signals selectable
- Separate digital-to-analog converters (9-bit resolution for Y; 8-bit for colour-difference signals)
- 1 V (p-p)/ 75  $\Omega$  outputs realized by two resistors
- No external adjustments
- All functions controlled via I<sup>2</sup>C-bus

## 2. QUICK REFERENCE DATA

SYMBOL	PARAMETER	MIN.	TYP.	MAX.	UNIT
V <sub>DD</sub>	supply voltage digital part	4.5	5	5.5	V
V <sub>DDA</sub>	supply voltage analog part	4.75	5	5.25	V
I <sub>DD</sub>	total supply current	-	-	160	mA
V <sub>IL</sub>	input voltage LOW on YUV-bus	-0.5	-	0.8	V
V <sub>IH</sub>	input voltage HIGH on YUV-bus	2	-	V <sub>DD</sub> +0.5	V
f <sub>LLC</sub>	input data rate	-	-	45	MHz
V <sub>O Y,CD</sub>	output signal Y, $\pm(R-Y)$ and $\pm(B-Y)$ (peak-to-peak value)	-	2	-	V
R <sub>L Y,CD</sub>	output load resistance	125	-	-	$\Omega$
ILE	DC integral linearity error in output signal (8-bit data)	-	-	1	LSB
DLE	DC differential error in output signal (8-bit data)	-	-	0.5	LSB
T <sub>amb</sub>	operating ambient temperature range	0	-	70	°C

## 3. ORDERING INFORMATION

EXTENDED TYPE NUMBER	PACKAGE			
	PINS	PIN POSITION	MATERIAL	CODE
SAA7164	44	PLCC	plastic	SOT187

# Video enhancement and D/A processor (VEDA3)

# SAA7164

## 4. BLOCK DIAGRAM

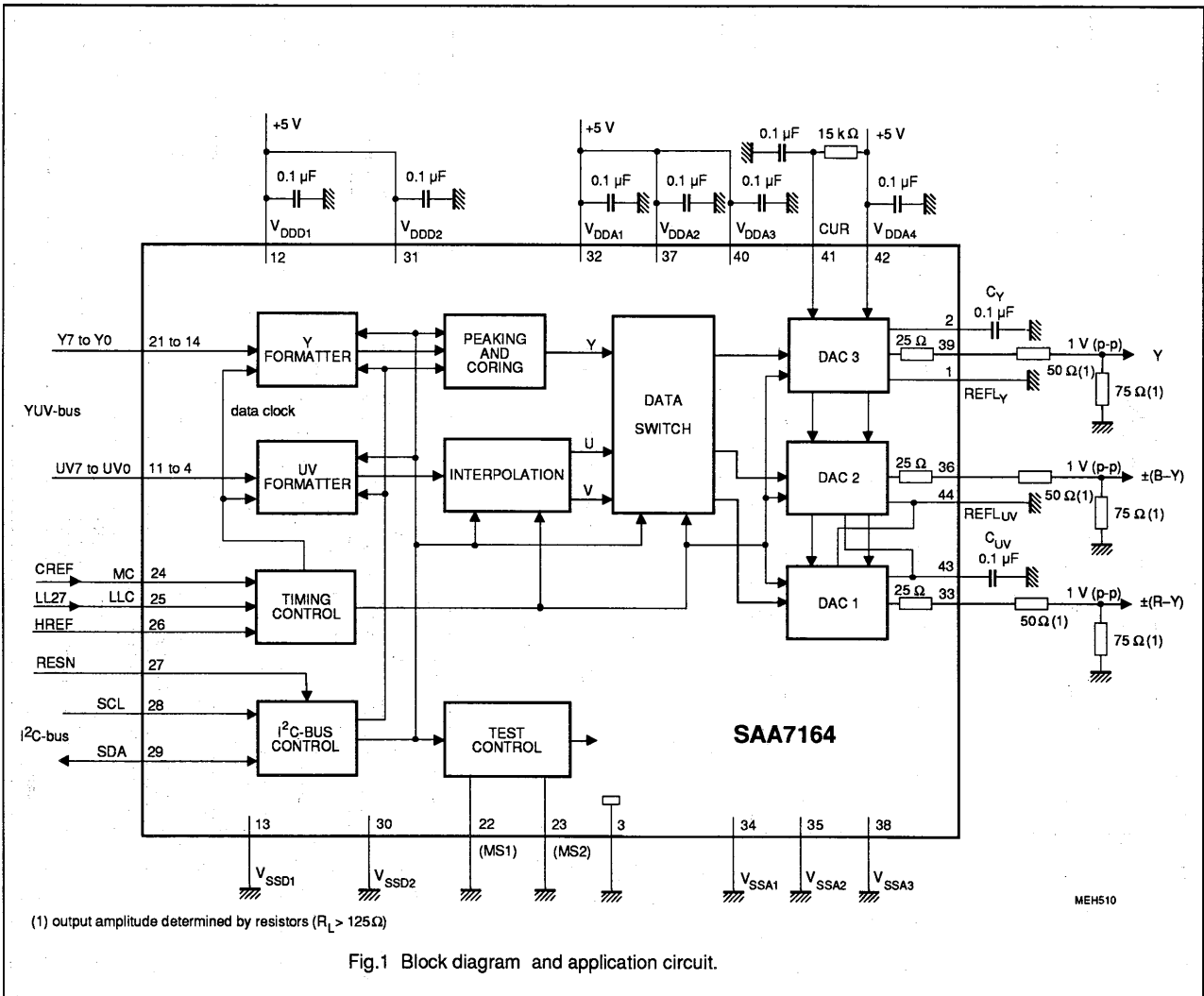

Fig.1 Block diagram and application circuit.

## Video enhancement and D/A processor (VEDA3)

SAA7164

## 5. PINNING

SYMBOL	PIN	DESCRIPTION
REFLY	1	low reference of luminance DAC (connected to V <sub>SSA1</sub> )
C <sub>Y</sub>	2	capacitor for luminance DAC (high reference)
SUB	3	substrate (connected to V <sub>SSA1</sub> )
UVO	4	UV signal input bits UV7 to UV0 (digital colour-difference signal)
UV1	5	
UV2	6	
UV3	7	
UV4	8	
UV5	9	
UV6	10	
UV7	11	
V <sub>DD1</sub>	12	+5 V digital supply voltage 1
V <sub>SS1</sub>	13	digital ground 1 (0 V)
Y0	14	Y signal input bits Y7 to Y0 (digital luminance signal)
Y1	15	
Y2	16	
Y3	17	
Y4	18	
Y5	19	
Y6	20	
Y7	21	
MS2	22	mode select 2 input for testing chip
MS1	23	mode select 1 input for testing chip
MC	24	data clock CREF (13.5 MHz e. g.); at MC = HIGH the LLC divider-by-two is inactive
LLC	25	line-locked clock signal (LL27 = 27 MHz)
HREF	26	data clock for YUV data inputs (for active line 768Y or 640Y long)
RESN	27	reset input (active LOW)
SCL	28	I <sup>2</sup> C-bus clock line
SDA	29	I <sup>2</sup> C-bus data line
V <sub>SS2</sub>	30	digital ground 2 (0 V)
V <sub>DD2</sub>	31	+5 V digital supply voltage 2
V <sub>DDA1</sub>	32	+5 V analog supply voltage for buffer of DAC 1
(R-Y)	33	±(R-Y) output signal (analog signal)
V <sub>SSA1</sub>	34	analog ground 1 (0 V)



# Video enhancement and D/A processor (VEDA3)

# SAA7164

SYMBOL	PIN	DESCRIPTION
V <sub>SSA2</sub>	35	analog ground 2 (0 V)
(B-Y)	36	±(B-Y) output signal (analog colour-difference signal)
V <sub>DDA2</sub>	37	+5 V analog supply voltage for buffer of DAC 2
V <sub>SSA3</sub>	38	analog ground 3 (0 V)
Y	39	Y output signal (analog luminance signal)
V <sub>DDA3</sub>	40	+5 V analog supply voltage for buffer of DAC 3
CUR	41	current input for analog output buffers
V <sub>DDA4</sub>	42	supply and reference voltage for the three DACs
C <sub>UV</sub>	43	capacitor for chrominance DACs (high reference)
REFL <sub>UV</sub>	44	low reference of chrominance DACs (connected to V <sub>SSA1</sub> )

## PIN CONFIGURATION

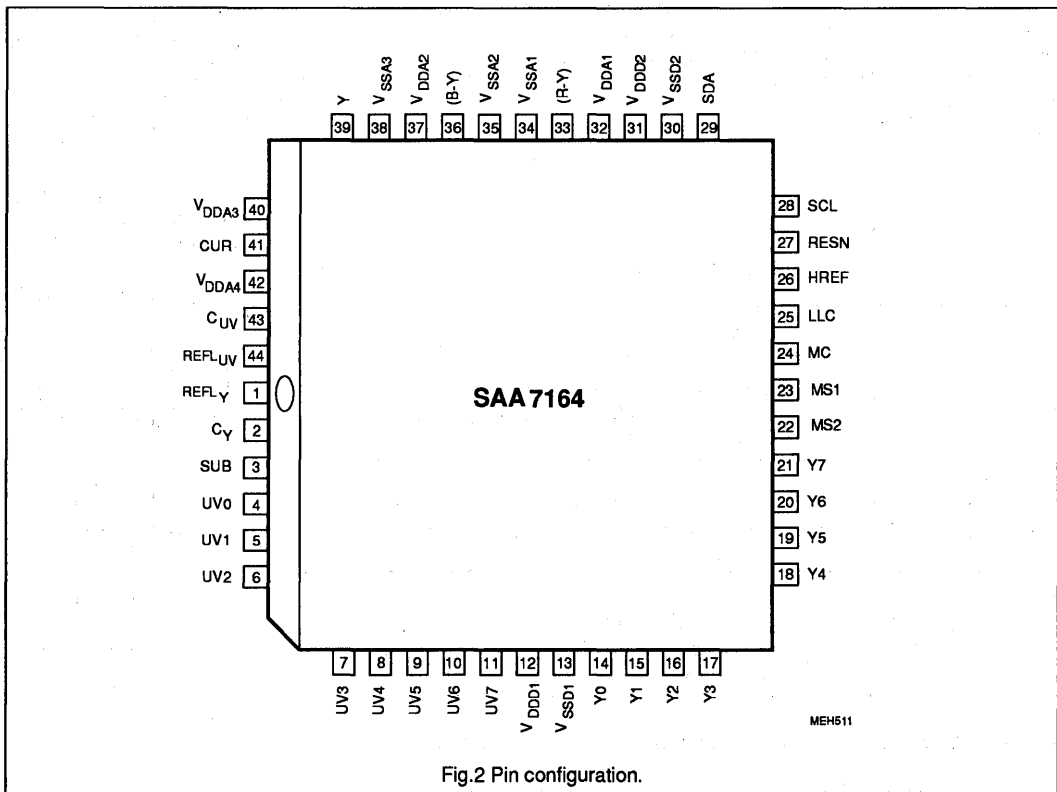

Fig.2 Pin configuration.

# Video enhancement and D/A processor (VEDA3)

SAA7164

## FUNCTIONAL DESCRIPTION

The CMOS circuit SAA7164 processes digital YUV-bus data up to a data rate of 45 MHz. The data inputs Y7 to Y0 and UV7 to UV0 (Fig.1) are provided with 8-bit data. The data of digital colour-difference signals U and V are in a multiplexed state (serial in 4:2:2 or 4:1:1 format; Tables 2 and 3).

Data is read with the rising edge of LLC (line-locked clock) to achieve a data rate of LLC at MC = HIGH only. If MC is supplied with the frequency CREF (LLC/2 for example), data is read only at every second rising edge (Fig.3). The 7-bit YUV data are also supported by means of the R78-bit (R78 = 0). Additionally, the luminance data format is converted for internal use into a two's complement format by inverting MSB. The Y input byte (bits Y7 to Y0) represent luminance information; the UV input byte (bits UV7 to UV0) one of the two digital colour-difference signals in 4:2:2 format (Table 2).

Table 1 LLC and MC configuration modes in DMSD applications

PIN	INPUT SIGNAL	COMMENT
LLC MC	LLC (LL27) CREF	The data rate on YUV-bus is half the clock rate on pin LLC, e. g. in SAA7151B, SAA7191 and SAA7191B single scan operation.
LLC MC	LLC (LL27) MC = HIGH	The data rate on YUV-bus must be identical to the clock rate on pin LLC, e. g. in double scan applications.
LLC MC	LLC2/LL3 MC = HIGH	The data rate on YUV-bus must be identical to the clock rate on pin LLC, e. g. SAA9051 single scan operation.
Note: YUV data are only latched with the rising edge of LLC at MC = HIGH.		

The HREF input signal (HREF = HIGH) determines the start and the end of an active line (Fig.3), the number of pixels respectively. The analog output Y is blanked at HREF = LOW, the (B-Y) and (R-Y) outputs are in a colourless state. The blanking level can be set by the BLV-bit. The SAA7164 controllable via the I<sup>2</sup>C-bus

### Y and UV formatters

The input data formats are formatted into the internally used processing formats (separate for 4:2:2 and 4:1:1 formats). The IFF, IFC and IFL bits control the input data format and determine the right interpolation filter (Figures 10 to 13).

### Peaking and coring

Peaking is applied to the Y signal to compensate several bandwidth reductions of the external pre-processing. Y signals can be improved to obtain a better sharpness.

There are the two switchable bandpass filters BF1 and BF 2 controlled via the I<sup>2</sup>C-bus by the bits BP1, BP0 and BFB. Thus, a frequency response is achieved in combination with the peaking factor K (Figures 5 to 9; K is determined by the bits BFB, WG1 and WG0).

The coring stage with controllable threshold (4 states controlled by CO1 and CO0 bits) reduces noise disturbances (generated by the bandpass gain) by suppressing the amplitude of small high-frequency signal components. The remaining high-frequency peaking component is available for a weighted addition after coring.

Table 2 Data format 4 : 2 : 2. (Fig.3)

INPUT	PIXEL BYTE SEQUENCE					
Y0 (LSB)	Y0	Y0	Y0	Y0	Y0	Y0
Y1	Y1	Y1	Y1	Y1	Y1	Y1
Y2	Y2	Y2	Y2	Y2	Y2	Y2
Y3	Y3	Y3	Y3	Y3	Y3	Y3
Y4	Y4	Y4	Y4	Y4	Y4	Y4
Y5	Y5	Y5	Y5	Y5	Y5	Y5
Y6	Y6	Y6	Y6	Y6	Y6	Y6
Y7 (MSB)	Y7	Y7	Y7	Y7	Y7	Y7
UV0 (LSB)	U0	V0	U0	V0	U0	V0
UV1	U1	V1	U1	V1	U1	V1
UV2	U2	V2	U2	V2	U2	V2
UV3	U3	V3	U3	V3	U3	V3
UV4	U4	V4	U4	V4	U4	V4
UV5	U5	V5	U5	V5	U5	V5
UV6	U6	V6	U6	V6	U6	V6
UV7(MSB)	U7	V7	U7	V7	U7	V7
Y frame	0	1	2	3	4	5
UV frame	0		2		4	

## Video enhancement and D/A processor (VEDA3)

SAA7164

**Interpolation**

The chrominance interpolation filter consists of various filter stages, multiplexers and de-multiplexers to increase the data rate of the colour-difference signals by a factor of 2 or 4. The switching of the filters by the bits IFF, IFC and IFL is described previously. Additional signal samples with significant amplitudes between two consecutive signal samples of the low data rate are generated. The time-multiplexed U and V samples are stored in parallel for converting.

**Data switch**

The digital signals are adapted to the conversation range. U and V data have 8-bit formats again; Y can have 9 bits dependent on peaking. Blanking and switching to colourless level is applied here. Bits can be inverted by INV-bit to change the polarity of colour-difference output signals.

**Digital-to-analog converters**

Conversion is separate for Y, U and V. The converters use resistor chains with low-impedance output buffers. The minimum output voltage is 200 mV to reduce integral

non-linearity errors. The analog signal, without load on output pin, is between 0.2 and 2.2 V floating. An application for 1 V/75  $\Omega$  on outputs is shown in Fig.1.

Each digital-to-analog converter has its own supply and ground pins suitable for decoupling. The reference voltage, supplying the resistor chain of all three DACs, is the supply voltage  $V_{DDA4}$ . The current into pin 41 is 0.3 mA ; a larger current improves the bandwidth but increases the integral non-linearity.

**Table 3** Data format 4 : 1 : 1

INPUT	PIXEL BYTE SEQUENCE							
	Y0	Y0	Y0	Y0	Y0	Y0	Y0	Y0
Y0	Y0	Y0	Y0	Y0	Y0	Y0	Y0	Y0
Y1	Y1	Y1	Y1	Y1	Y1	Y1	Y1	Y1
Y2	Y2	Y2	Y2	Y2	Y2	Y2	Y2	Y2
Y3	Y3	Y3	Y3	Y3	Y3	Y3	Y3	Y3
Y4	Y4	Y4	Y4	Y4	Y4	Y4	Y4	Y4
Y5	Y5	Y5	Y5	Y5	Y5	Y5	Y5	Y5
Y6	Y6	Y6	Y6	Y6	Y6	Y6	Y6	Y6
Y7	Y7	Y7	Y7	Y7	Y7	Y7	Y7	Y7
UV0	0	0	0	0	0	0	0	0
UV1	0	0	0	0	0	0	0	0
UV2	0	0	0	0	0	0	0	0
UV3	0	0	0	0	0	0	0	0
UV4	V6	V4	V2	V0	V6	V4	V2	V0
UV5	V7	V5	V3	V1	V7	V5	V3	V1
UV6	U6	U4	U2	U0	U6	U4	U2	U0
UV7	U7	U5	U3	U1	U7	U5	U3	U1
Y frame	0	1	2	3	4	5	6	7
UV frame	0				4			

Video enhancement and D/A processor (VEDA3)

SAA7164

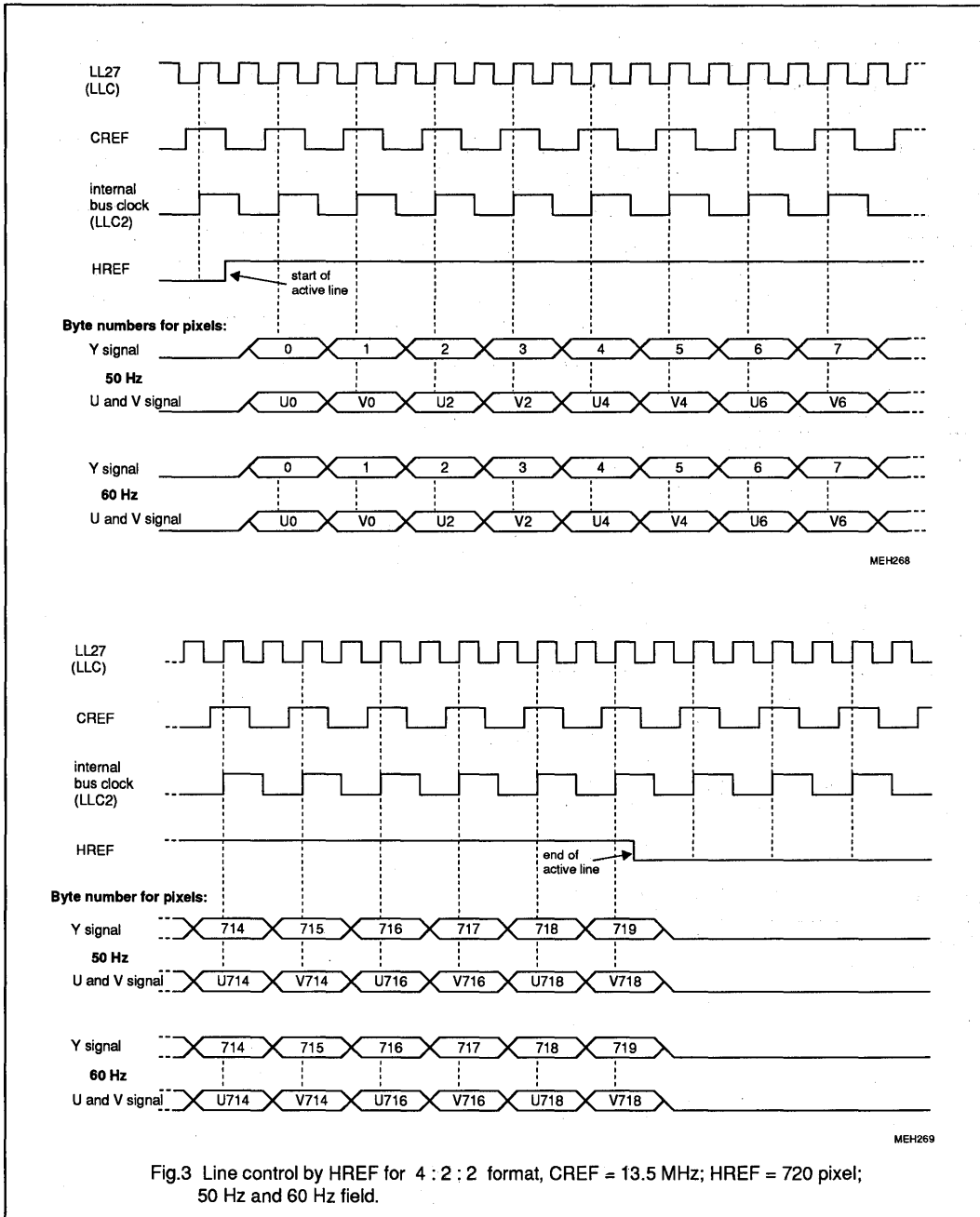

Fig.3 Line control by HREF for 4 : 2 : 2 format, CREF = 13.5 MHz; HREF = 720 pixel; 50 Hz and 60 Hz field.

## Video enhancement and D/A processor (VEDA3)

SAA7164

**7. LIMITING VALUES**

In accordance with the Absolute Maximum Rating System (IEC 134).

SYMBOL	PARAMETER	MIN.	MAX.	UNIT
V <sub>DDD1</sub>	supply voltage range (pin 12)	-0.3	7	V
V <sub>DDD2</sub>	supply voltage range (pin 31)	-0.3	7	V
V <sub>DDA1</sub>	supply voltage range (pin 32)	-0.3	7	V
V <sub>DDA2</sub>	supply voltage range (pin 37)	-0.3	7	V
V <sub>DDA3</sub>	supply voltage range (pin 40)	-0.3	7	V
V <sub>DDA4</sub>	supply voltage range (pin 42)	-0.3	7	V
V <sub>diff GND</sub>	difference voltage V <sub>SSD</sub> - V <sub>SSA</sub>	-	±100	mV
V <sub>n</sub>	voltage on all input pins 4 to 11, 14 to 27 and 41	-0.3	V <sub>DDD</sub>	V
V <sub>n</sub>	voltage on analog output pins 33, 36 and 39	-0.3	V <sub>DDD</sub>	V
P <sub>tot</sub>	total power dissipation	0	tbf	mW
T <sub>stg</sub>	storage temperature range	-55	150	°C
T <sub>amb</sub>	operating ambient temperature range	0	70	°C
V <sub>ESD</sub>	electrostatic handling* for all pins	±2000	-	V

\* Equivalent to discharging a 100 pF capacitor through a 1.5 kΩ series resistor.

**8. THERMAL RESISTANCE**

SYMBOL	PARAMETER	THERMAL RESISTANCE
R <sub>th j-a</sub>	from junction-to-ambient in free air	46 K/W

## Video enhancement and D/A processor (VEDA3)

SAA7164

## 9. CHARACTERISTICS

$V_{DD} = 4.5$  to  $5.5$  V;  $V_{DDA} = 4.75$  to  $5.25$  V; LLC = LL27; MC = CREF = 13.5 MHz;  $T_{amb} = 0$  to  $70$  °C; measurements taken in Fig.1 unless otherwise specified.

SYMBOL	PARAMETER	CONDITIONS	MIN.	TYP.	MAX.	UNIT
$V_{DD1}$	supply voltage range (pin 12)	for digital part	4.5	5	5.5	V
$V_{DD2}$	supply voltage range (pin 31)	for digital part	4.5	5	5.5	V
$V_{DDA1}$	supply voltage range (pin 32)	for buffer of DAC 1	4.75	5	5.25	V
$V_{DDA2}$	supply voltage range (pin 37)	for buffer of DAC 2	4.75	5	5.25	V
$V_{DDA3}$	supply voltage range (pin 40)	for buffer of DAC 3	4.75	5	5.25	V
$V_{DDA4}$	supply voltage range (pin 42)	DAC reference voltage	4.75	5	5.25	V
$I_{DD}$	supply current ( $I_{DD1} + I_{DD2}$ )	for digital part	-	-	140	mA
$I_{DDA}$	supply current ( $I_{DDA1}$ to $I_{DDA4}$ )	for DACs and buffers	-	-	20	mA
<b>YUV-bus inputs (pins 4 to 11 and 14 to 21)</b>		Figures 3 and 4				
$V_{IL}$	input voltage LOW		-0.5	-	0.8	V
$V_{IH}$	input voltage HIGH		2.0	-	$V_{DD}+0.5$	V
$C_I$	input capacitance	$V_I = \text{HIGH}$	-	-	10	pF
$I_{LI}$	input leakage current		-	-	4.5	$\mu\text{A}$
<b>Inputs MS1, MS2, MC, LLC, HREF and RESN (pins 22 to 27)</b>						
$V_{IL}$	input voltage LOW		-0.5	-	0.8	V
$V_{IH}$	input voltage HIGH		2.0	-	$V_{DD}+0.5$	V
$C_I$	input capacitance	$V_I = \text{HIGH}$	-	-	10	pF
$I_{LI}$	input leakage current		-	-	4.5	$\mu\text{A}$
$V_{24}$	MC input voltage for LL27	27 MHz data rate	2.0	-	$V_{DD}+0.5$	V
	CREF signal on MC input	CREF data rate; note 1	-	-	-	V
<b>I<sup>2</sup>C-bus SCL and SDA (pins 28 and 29)</b>						
$V_{IL}$	input voltage LOW		-0.5	-	1.5	V
$V_{IH}$	input voltage HIGH		3.0	-	$V_{DD}+0.5$	V
$I_I$	input current	$V_I = \text{LOW or HIGH}$	-	-	$\pm 10$	$\mu\text{A}$
$V_{OL}$	SDA output voltage LOW (pin 29)	$I_{29} = 3$ mA	-	-	0.4	V
$I_{29}$	output current	during acknowledge	3	-	-	mA
<b>Digital-to-analog converters (pins 1, 2, 41, 42, 43 and 44)</b>						
$V_{DAC}$	input reference voltage for internal resistor chains (pin 42)		4.75	5	5.25	V
$I_{CUR}$	input current (pin 41)	$R_{41-42} = 15$ k $\Omega$	-	300	-	$\mu\text{A}$
$V_{1,44}$	reference voltage LOW	pin connected to $V_{SSA1}$	-	0	-	V
$C_L$	external blocking capacitor to $V_{SSA1}$ for reference voltage HIGH (pins 2 and 43)		-	0.1	-	$\mu\text{F}$

## Video enhancement and D/A processor (VEDA3)

SAA7164

SYMBOL	PARAMETER	CONDITIONS	MIN.	TYP.	MAX.	UNIT
$f_{LLC}$	data conversation rate (clock)	Fig.3	-	-	45	MHz
Res	resolution	luminance DAC	-	9	-	bit
		chrominance DACs	-	8	-	bit
ILE	DC integral linearity error	8-bit data	-	-	1.0	LSB
DLE	DC differential error	8-bit data	-	-	0.5	LSB
<b>Y, <math>\pm(R-Y)</math> and <math>\pm(B-Y)</math> analog outputs (pins 39, 33 and 36)</b>						
$V_o$	output signal voltage (peak-to-peak value)	without load	-	2	-	V
$V_{33,36,39}$	output voltage range	without load; note 2	0.2	-	2.2	V
$V_{39}$	output blanking level	Y output; note 3	-	16	-	LSB
$V_{33,36}$	output no-colour level	$\pm(R-Y)$ , $\pm(B-Y)$ ; note 4	-	128	-	LSB
$R_{33,36,39}$	internal serial output resistance		-	25	-	$\Omega$
$R_{L 33,36,39}$	output load resistance	external load	125	-	-	$\Omega$
B	output signal bandwidth	-3 dB	20	-	-	MHz
$t_d$	signal delay from input to Y output		-	tbf	-	ns
<b>LLC timing (pins 25)</b>			LLC; Fig.3			
$t_{LLC}$	cycle time		22.2	37	41	ns
$t_{pH}$	pulse width		40	50	60	%
$t_r$	rise time		-	-	5	ns
$t_f$	fall time		-	-	6	ns
<b>YUV-bus timing (pins 4 to 11 and 14 to 21)</b>			Fig.5			
$t_{SU}$	input data set-up time		6	-	-	ns
$t_{HD}$	input data hold time		3	-	-	ns
<b>MC timing (pin24)</b>			Fig.5			
$t_{SU}$	input data set-up time		6	-	-	ns
$t_{HD}$	input data hold time		3	-	-	ns
<b>RESN timing (pin 27)</b>						
$t_{SU}$	set-up time after power-on or failure	active LOW; note 5	$4 \times t_{LLC}$	-	-	ns

**Notes to the characteristics**

- YUV-bus data is read at MC = HIGH (pin 24) clocked with LLC (Fig.5) . Data is read only with every second rising edge of LLC when CREF = LLC/2 on MC-pin 24.
- 0.2 to 2.2 V output voltage range at 8-bit DAC input data. The data word can increase to 9-bit dependent on peaking factor.
- The luminance signal is set to the digital black level: 16 LSB for BLV-bit = 0; 0 LSB for BLV-bit = 1.
- The chrominance amplitudes are set to the digital colourless level of 128 LSB.
- The circuit is prepared for a new data initialization.

Video enhancement and D/A processor (VEDA3)

SAA7164

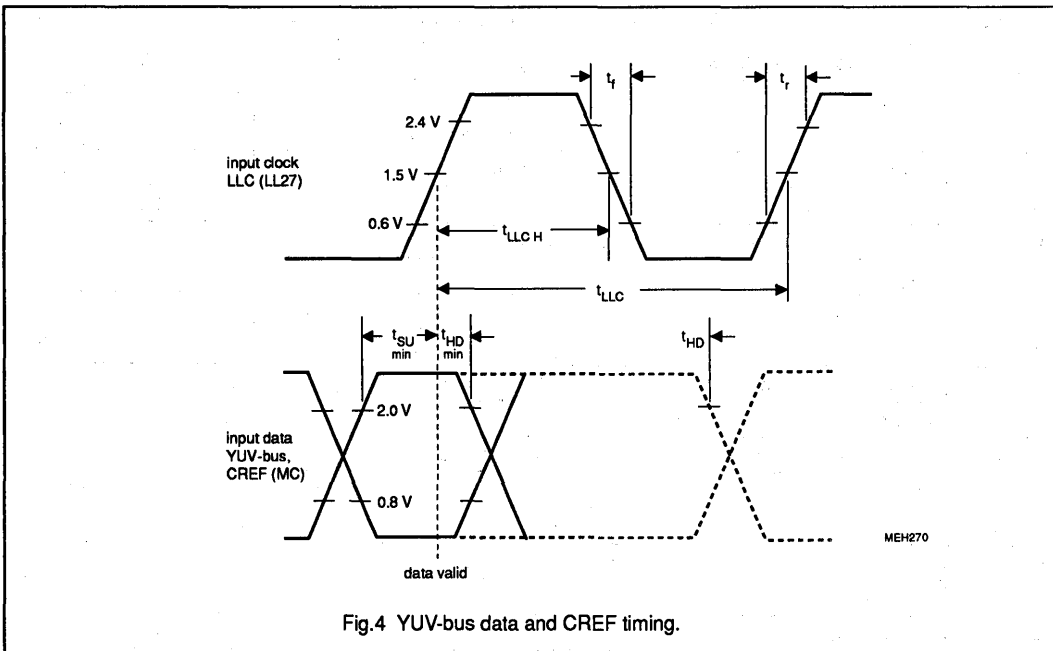

PROCESSING DELAY	LLC CYCLES	REMARKS
YUV digital input to YUV analog output	44	at MC = "1"
	88	at MC = LLC/2



# Video enhancement and D/A processor (VEDA3)

SAA7164

## 10. I<sup>2</sup>C-BUS FORMAT

S	SLAVE ADDRESS	A	SUBADDRESS	A	DATA0	A		DATA <sub>n</sub>	A	P
---	---------------	---	------------	---	-------	---	--	-------------------	---	---

- S = start condition
- SLAVE ADDRESS = **1011 111X**
- A = acknowledge, generated by the slave
- SUBADDRESS\* = subaddress byte (Table 4)
- DATA = data byte (Table 4)
- P = stop condition
  
- X = read/write control bit  
 X = 0, order to write (the circuit is slave receiver)  
 X = 1, order to read (the circuit is slave transmitter)

\* If more than 1 byte DATA are transmitted, then auto-increment of the subaddress is performed.

**Table 4** I<sup>2</sup>C-bus transmission

FUNCTION	SUBADDRESS	DATA								
		D7	D6	D5	D4	D3	D2	D1	D0	
Peaking and coring	01	0	CO1	CO0	BP1	BP0	BFB	WG1	WG0	
Input formats; interpolation	02	IFF	IFC	IFL	0	0	0	0	0	
Input/output setting	03	0	0	0	0	DRP	BLV	R78	INV	

Bit functions in data bytes:					
CO1 to CO0	Control of coring threshold:	CO1 CO0		<hr/> coring off small noise reduction medium noise reduction high noise reduction	
		0	0		
		0	1		
		1	0		
		1	1		
BP1, BP0 and BFB	Bandpass filter selection:	BP1 BP0 BFB			<hr/> characteristic Fig.5 characteristic Fig.6 characteristic Fig.7 characteristic Fig.8  BF1 filter bypassed Fig.9 not recommended
		0	0	0	
		0	1	0	
		1	0	0	
		1	1	0	
		0	0	1	
X	X	1			

Video enhancement and D/A processor (VEDA3)

SAA7164

BFB, WG1 and WG0	Peaking factor K:	BFB	WG1	WG0	K = 1/8; minimum peaking K = 1/4 K = 1/2 K = 1; maximum peaking K = 0; peaking off K = 1/4; minimum peaking K = 1/2 K = 1; maximum peaking
		0	0	0	
		0	0	1	
		0	1	0	
		0	1	1	
		1	0	0	
		1	0	1	
		1	1	1	
IFF, IFC, IFL	Input format and filter control at 13.5 MHz data rate:	IFF	IFC	IFL	4 : 1 : 1 format; -3 dB attenuation at 1.6 MHz video frequency; Fig.10 4 : 1 : 1 format; -3 dB attenuation at 600 kHz video frequency; Fig.11 4 : 1 : 1 format; -3 dB attenuation at 1.2 MHz video frequency; Fig.12  4 : 2 : 2 format; -3 dB attenuation at 1.6 MHz video frequency; Fig.10 4 : 2 : 2 format; -3 dB attenuation at 600 kHz video frequency; Fig.11 4 : 2 : 2 format; -3 dB attenuation at 2.5 MHz video frequency; Fig.13
		0	0	0	
		0	0	1	
		0	1	0	
		1	0	0	
		1	0	1	
		1	1	X	
DRP	UV input data code:	0 = two's complement; 1 = offset binary			
BLV	Blanking level on Y output:	0 = 16 LSB; 1 = 0 LSB			
R78	YUV input data solution:	0 = 7-bit data; 1 = 8-bit data			
INV	Polarity of colour-difference output signals:	0 = normal polarity equal to input signal 1 = inverted polarity			

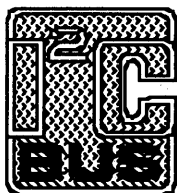

Purchase of Philips' I<sup>2</sup>C components conveys a license under the Philips' I<sup>2</sup>C patent to use the components in the I<sup>2</sup>C-system provided the system conforms to the I<sup>2</sup>C specifications defined by Philips.

Video enhancement and D/A processor (VEDA3)

SAA7164

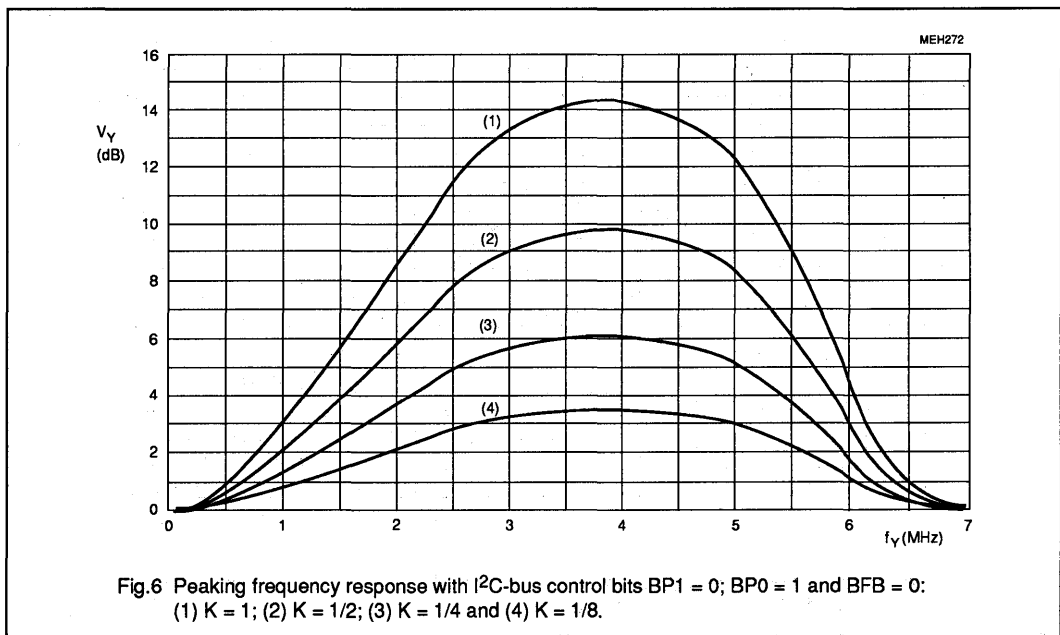
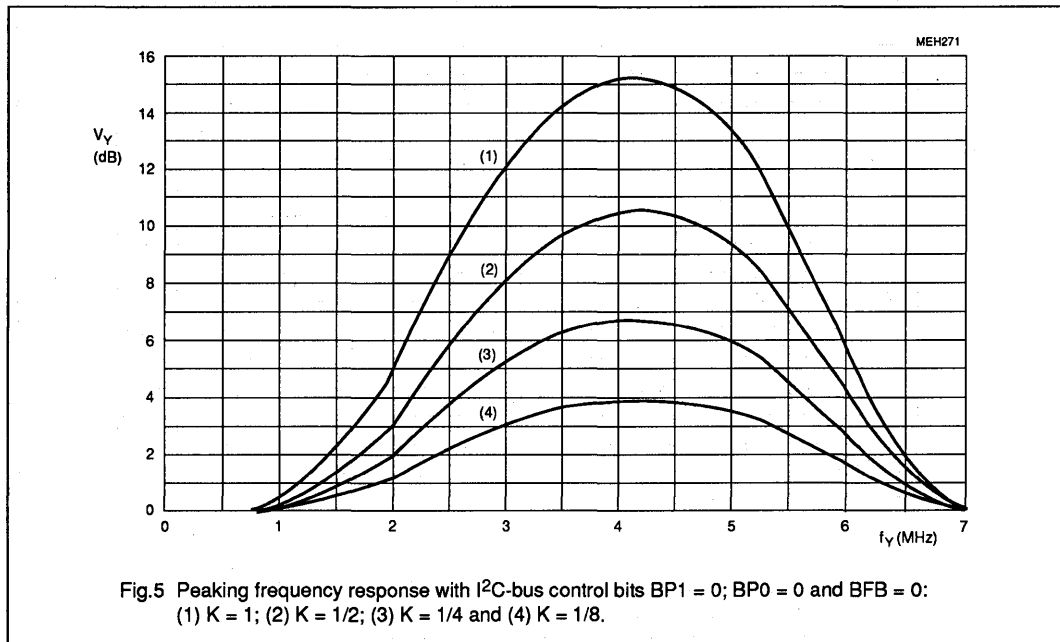

Video enhancement and D/A processor (VEDA3)

SAA7164

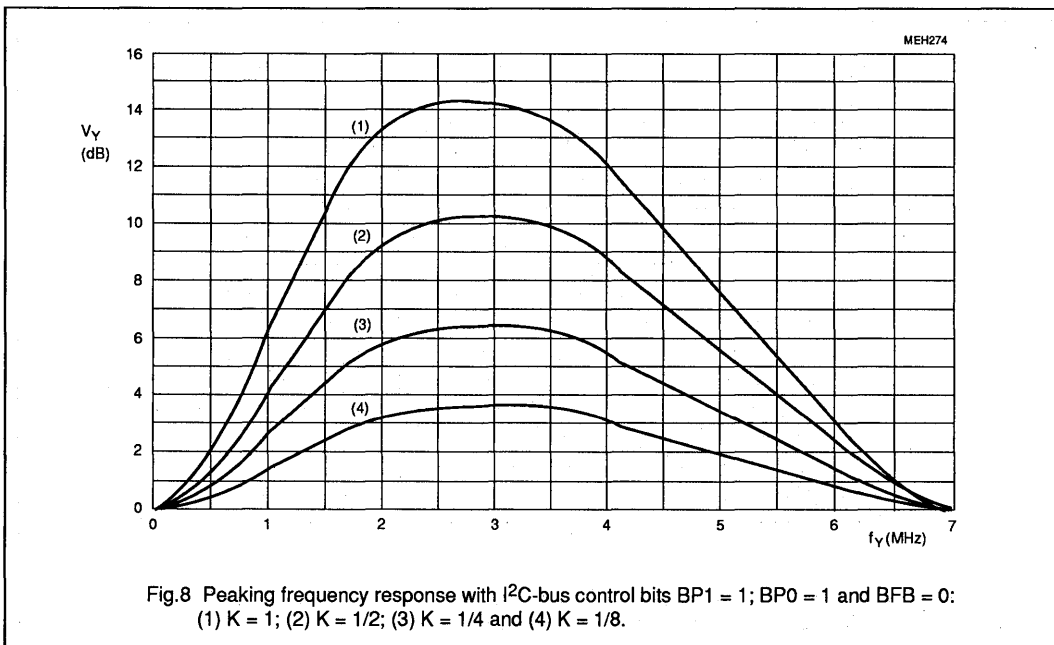
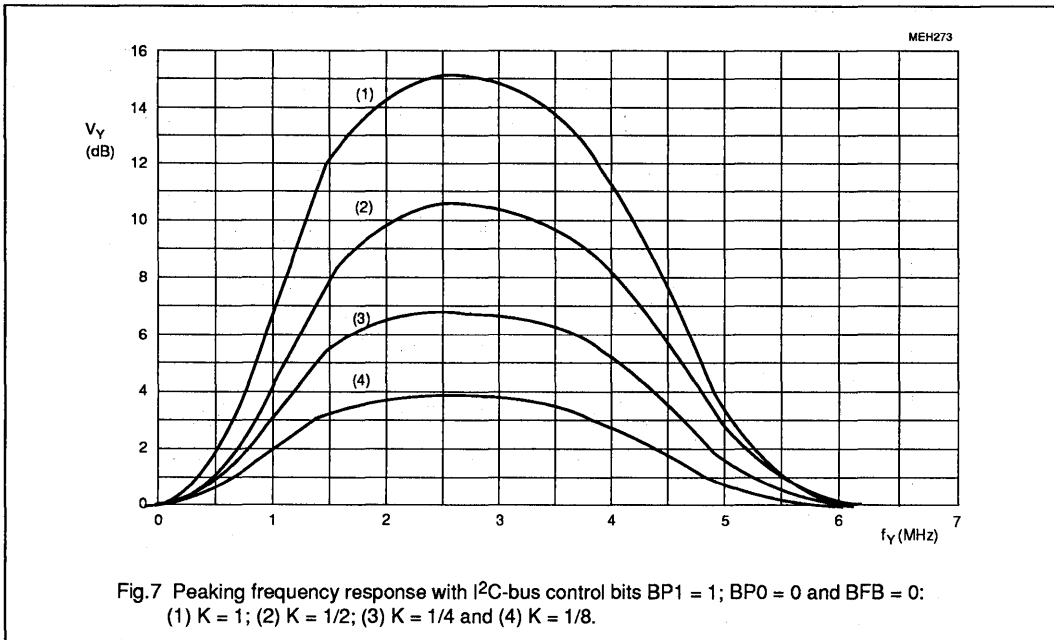

Video enhancement and D/A processor (VEDA3)

SAA7164

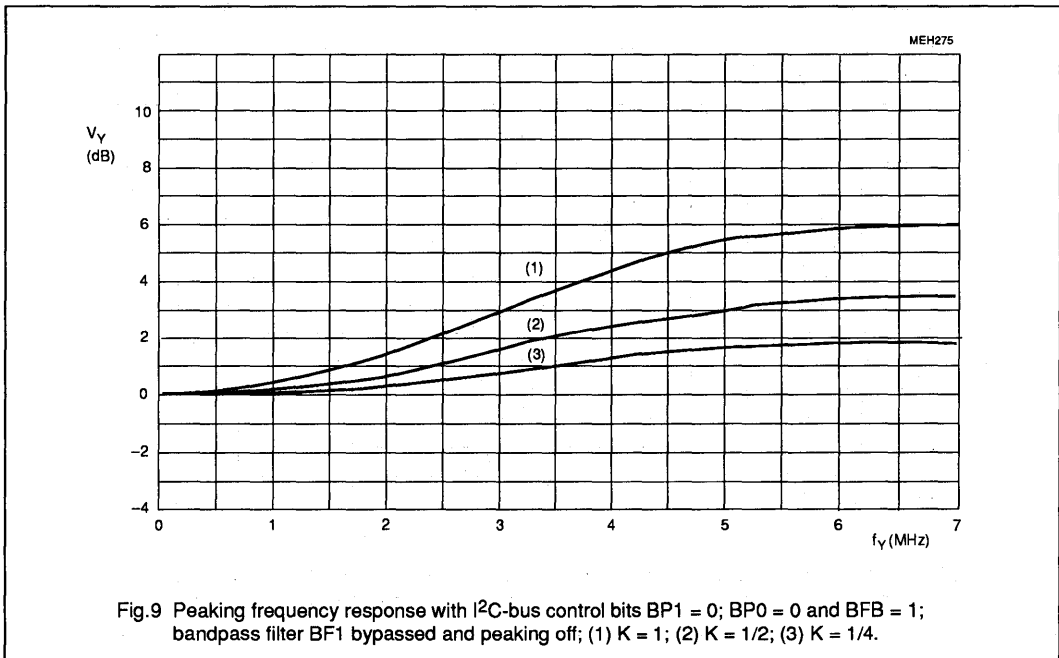

Video enhancement and D/A processor (VEDA3)

SAA7164

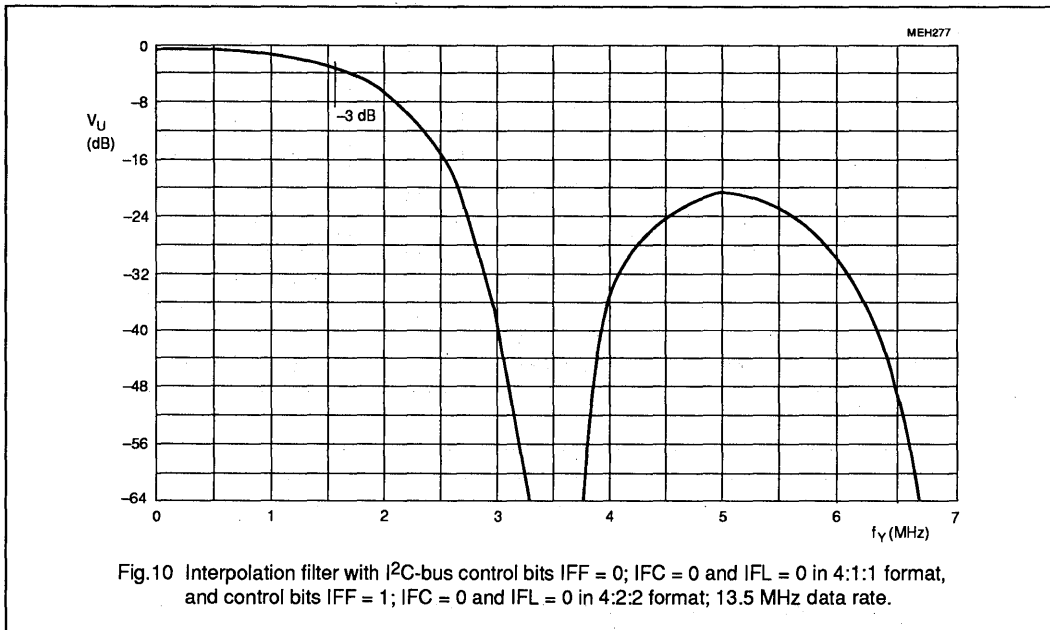

Fig.10 Interpolation filter with I<sup>2</sup>C-bus control bits IFF = 0; IFC = 0 and IFL = 0 in 4:1:1 format, and control bits IFF = 1; IFC = 0 and IFL = 0 in 4:2:2 format; 13.5 MHz data rate.

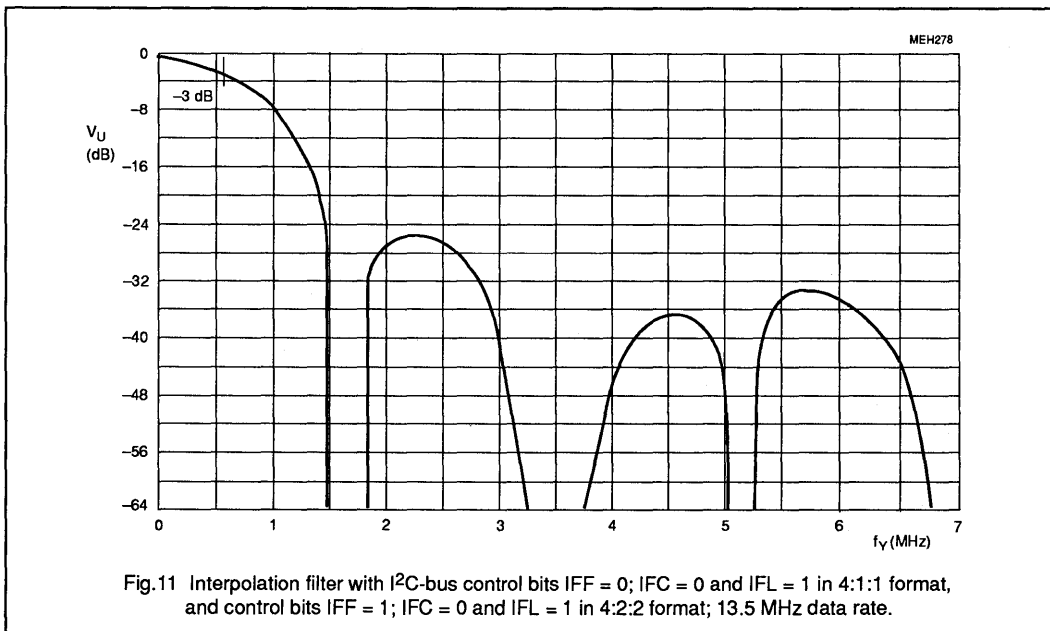
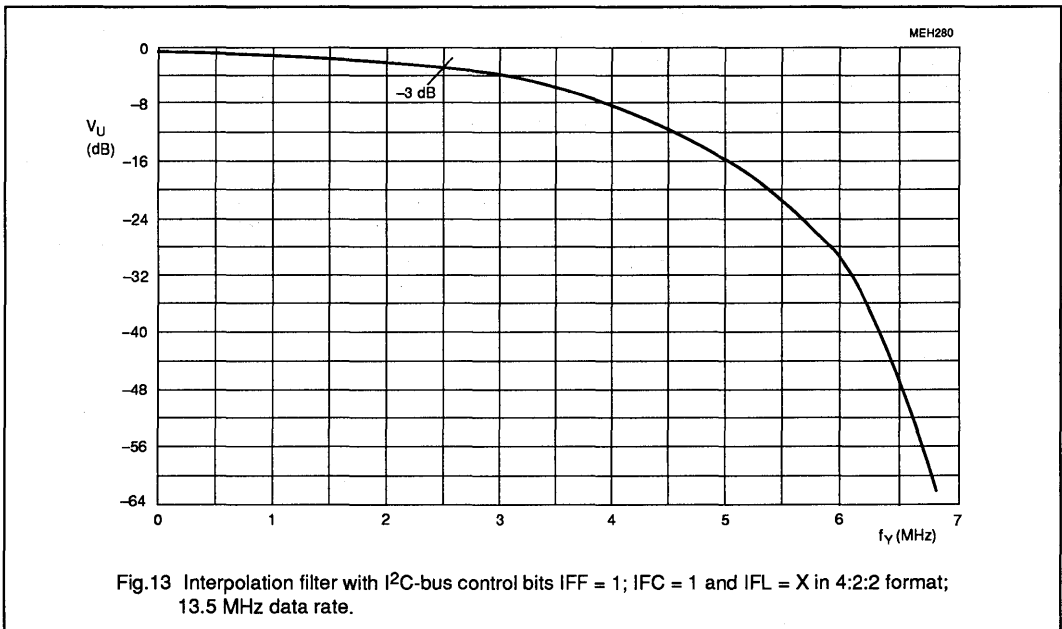
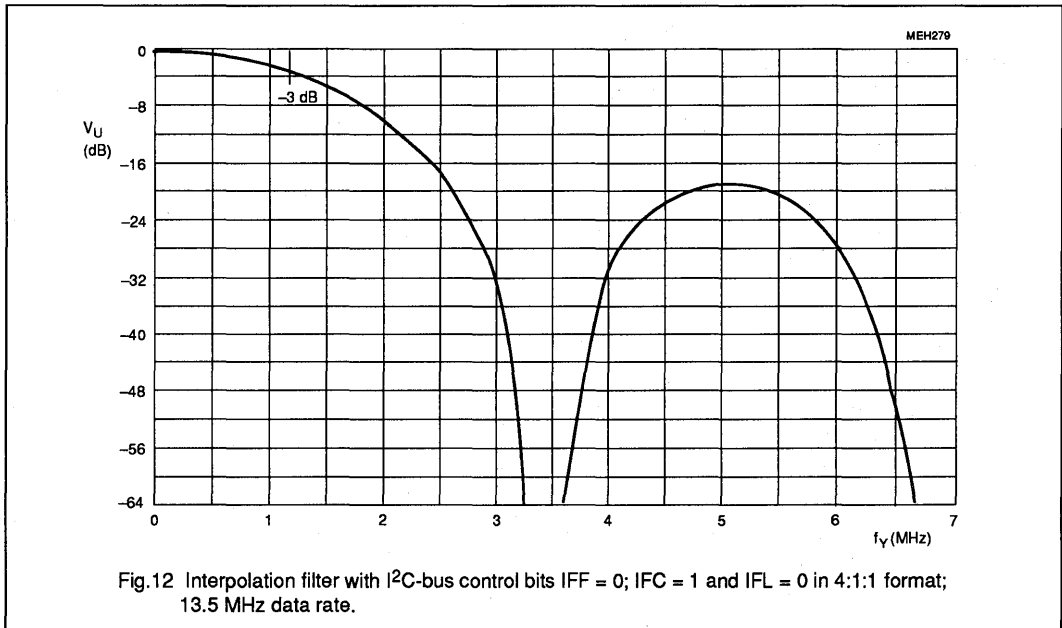

Fig.11 Interpolation filter with I<sup>2</sup>C-bus control bits IFF = 0; IFC = 0 and IFL = 1 in 4:1:1 format, and control bits IFF = 1; IFC = 0 and IFL = 1 in 4:2:2 format; 13.5 MHz data rate.

Video enhancement and D/A processor (VEDA3)

SAA7164



# Video enhancement and D/A processor (VEDA2)

SAA7165

## FEATURES

- CMOS circuit to enhance video data and to convert luminance and colour-difference signals from digital-to-analog
- Digital colour transient improvement block DCTI to increase the sharpness of colour transitions. The improved pin-compatible SAA7165 can supercede the SAA9065.
- 16-bit parallel input for 4:1:1 and 4:2:2 YUV data
- Data clock input LLC (line-locked clock) for a data rate up to 32 MHz
- 8-bit luminance and 8-bit multiplexed colour-difference formats (optional 7-bit formats)
- MC input to support various clock and pixel rates
- Formatter for YUV input data; 4:2:2 format, 4:1:1 format and filter characteristics selectable
- HREF input to determine the active line (number of pixels)
- Controllable peaking of luminance signal
- Coring stage with controllable threshold to eliminate noise in luminance signal
- Interpolation filter suitable for both formats to increase the data rate in chrominance path
- Polarity of colour-difference signals selectable
- All functions controlled via I<sup>2</sup>C-bus

SYMBOL	PARAMETER	MIN.	TYP.	MAX.	UNIT
V <sub>DDD</sub>	supply voltage digital part	4.5	5	5.5	V
V <sub>DDA</sub>	supply voltage analog part	4.75	5	5.25	V
I <sub>DD</sub>	total supply current	-	tb <sub>f</sub>	-	mA
V <sub>IL</sub>	input voltage LOW on YUV-bus	-0.5	-	0.8	V
V <sub>IH</sub>	input voltage HIGH on YUV-bus	2	-	V <sub>DDD</sub> +0.5	V
f <sub>LLC</sub>	input data rate	-	-	32	MHz
V <sub>o Y,CD</sub>	output signal Y, ±(R-Y) and ±(B-Y) (peak-to-peak value)	-	2	-	V
R <sub>L Y,CD</sub>	output load resistance	125	-	-	Ω
ILE	DC integral linearity error in output signal (8-bit data)	-	-	1	LSB
DLE	DC differential error in output signal (8-bit data)	-	-	0.5	LSB
T <sub>amb</sub>	operating ambient temperature range	0	-	70	°C

- Separate digital-to-analog converters (9-bit resolution for Y; 8-bit for colour-difference signals)
- 1 V (p-p)/ 75 Ω outputs realized by two resistors
- No external adjustments

## ORDERING INFORMATION

EXTENDED TYPE NUMBER	PACKAGE			
	PINS	PIN POSITION	MATERIAL	CODE
SAA7165	44	PLCC	plastic	SOT187



Video enhancement and D/A processor (VEDA2)

SAA7165

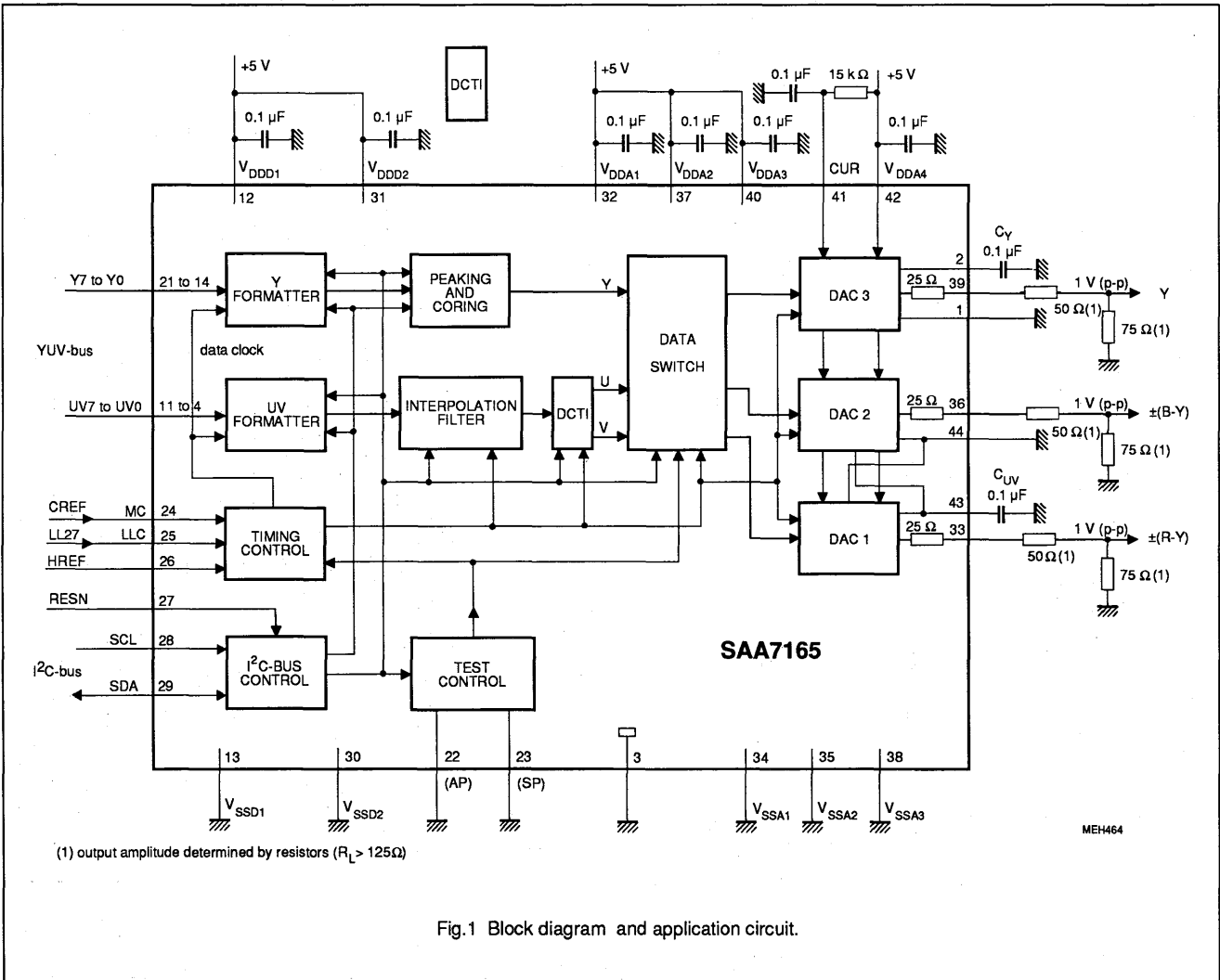

Fig.1 Block diagram and application circuit.

# Video enhancement and D/A processor (VEDA2)

SAA7165

## PINNING

SYMBOL	PIN	DESCRIPTION
REFLY	1	low reference of luminance DAC (connected to V <sub>SSA1</sub> )
C <sub>Y</sub>	2	capacitor for luminance DAC (high reference)
SUB	3	substrate (connected to V <sub>SSA1</sub> )
UVO	4	UV signal input bits UV7 to UV0 (digital colour-difference signal)
UV1	5	
UV2	6	
UV3	7	
UV4	8	
UV5	9	
UV6	10	
UV7	11	
V <sub>DDD1</sub>	12	+5 V digital supply voltage 1
V <sub>SSD1</sub>	13	digital ground 1 (0 V)
Y0	14	Y signal input bits Y7 to Y0 (digital luminance signal)
Y1	15	
Y2	16	
Y3	17	
Y4	18	
Y5	19	
Y6	20	
Y7	21	
AP	22	connected to ground (action pin for testing)
SP	23	connected to ground (shift pin for testing)
MC	24	data clock CREF (13.5 MHz e. g.); at MC = HIGH the LLC divider-by-two is inactive
LLC	25	line-locked clock signal (LL27 = 27 MHz)
HREF	26	data clock for YUV data inputs (for active line 768Y or 640Y long)
RESN	27	reset input (active LOW)
SCL	28	I <sup>2</sup> C-bus clock line
SDA	29	I <sup>2</sup> C-bus data line
V <sub>SSD2</sub>	30	digital ground 2 (0 V)
V <sub>DDD2</sub>	31	+5 V digital supply voltage 2
V <sub>DDA1</sub>	32	+5 V analog supply voltage for buffer of DAC 1
(R-Y)	33	±(R-Y) output signal (analog signal)
V <sub>SSA1</sub>	34	analog ground 1 (0 V)

# Video enhancement and D/A processor (VEDA2)

SAA7165

SYMBOL	PIN	DESCRIPTION
V <sub>SSA2</sub>	35	analog ground 2 (0 V)
(B-Y)	36	±(B-Y) output signal (analog colour-difference signal)
V <sub>DDA2</sub>	37	+5 V analog supply voltage for buffer of DAC 2
V <sub>SSA3</sub>	38	analog ground 3 (0 V)
Y	39	Y output signal (analog luminance signal)
V <sub>DDA3</sub>	40	+5 V analog supply voltage for buffer of DAC 3
CUR	41	current input for analog output buffers
V <sub>DDA4</sub>	42	supply and reference voltage for the three DACs
C <sub>UV</sub>	43	capacitor for chrominance DACs (high reference)
REF <sub>UV</sub>	44	low reference of chrominance DACs (connected to V <sub>SSA1</sub> )

## PIN CONFIGURATION

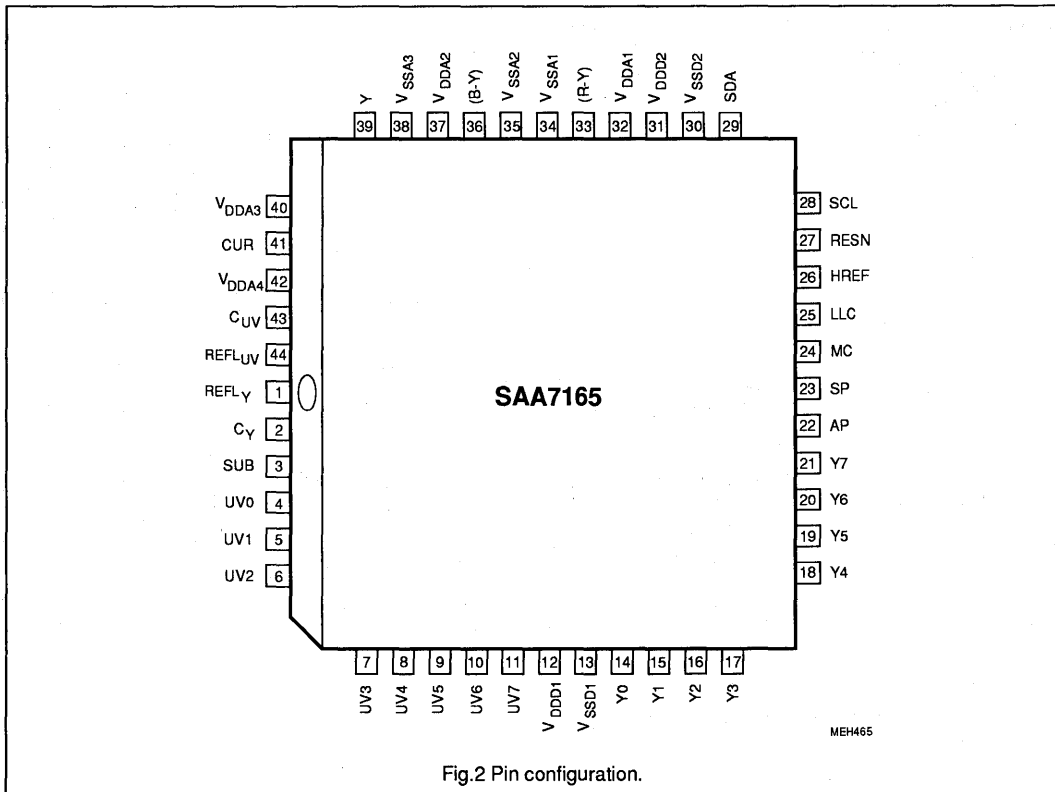

Fig.2 Pin configuration.

# Video enhancement and D/A processor (VEDA2)

SAA7165

## FUNCTIONAL DESCRIPTION

The CMOS circuit SAA7165 processes digital YUV-bus data up to a data rate of 30 MHz. The data inputs Y7 to Y0 and UV7 to UV0 (Fig.1) are provided with 8-bit data. The data of digital colour-difference signals U and V are in a multiplexed state (serial in 4:2:2 or 4:1:1 format; Tables 2 and 3).

Data is read with the rising edge of LLC (line-locked clock) to achieve a data rate of LLC at MC = HIGH only. If MC is supplied with the frequency CREF (LLC/2 for example), data is read only at every second rising edge (Fig.3). The 7-bit YUV input data are also supported by means of the R78-bit (R78 = 0). Additionally, the luminance data format is converted for internal use into a two's complement format by inverting MSB. The Y input byte (bits Y7 to Y0) represent luminance information; the UV input byte (bits UV7 to UV0) one of the two digital colour-difference signals in 4:2:2 format (Table 2).

The HREF input signal (HREF = HIGH) determines the start and the end of an active line (Fig.3) the number of pixels respectively. The analog output Y is blanked at HREF = LOW, the  $\pm(B-Y)$  and  $\pm(R-Y)$  outputs are in a colourless state. The blanking level can be set by the BLV-bit. The SAA7165 is controllable via the I<sup>2</sup>C-bus

### Y and UV formatters

The input data formats are formatted into the internally used processing formats (separate for 4:2:2 and 4:1:1 formats). The IFF, IFC and IFL bits control the input data format and determine the right interpolation filter (Figures 10 to 13).

### Peaking and coring

Peaking is applied to the Y signal to compensate several bandwidth reductions of the external pre-processing. Y signals can be improved to obtain a better sharpness.

There are the two switchable bandpass filters BF1 and BF 2 controlled via the I<sup>2</sup>C-bus by the bits BP1, BP0 and BFB. Thus, a frequency response is achieved in combination with the peaking factor K (Figures 5 to 9; K is determined by the bits BFB, WG1 and WG0).

The coring stage with controllable threshold (4 states controlled by CO1 and CO0 bits) reduces noise disturbances (generated by the bandpass gain) by suppressing the amplitude of small high-frequency signal components. The remaining high-frequency peaking component is available for a weighted addition after coring.

Table 1 LLC and MC configuration modes in DMSD applications

PIN	INPUT SIGNAL	COMMENT
LLC MC	LLC (LL27) CREF	The data rate on YUV-bus is half the clock rate on pin LLC, e. g. in SAA7151B, SAA7191 and SAA7191B single scan operation.
LLC MC	LLC (LL27) MC = HIGH	The data rate on YUV-bus must be identical to the clock rate on pin LLC, e. g. in double scan applications.
LLC MC	LLC2/LL3 MC = HIGH	The data rate on YUV-bus must be identical to the clock rate on pin LLC, e. g. SAA9051 single scan operation.
Note: YUV data are only latched with the rising edge of LLC at MC = HIGH.		

INPUT	PIXEL BYTE SEQUENCE					
Y0 (LSB)	Y0	Y0	Y0	Y0	Y0	Y0
Y1	Y1	Y1	Y1	Y1	Y1	Y1
Y2	Y2	Y2	Y2	Y2	Y2	Y2
Y3	Y3	Y3	Y3	Y3	Y3	Y3
Y4	Y4	Y4	Y4	Y4	Y4	Y4
Y5	Y5	Y5	Y5	Y5	Y5	Y5
Y6	Y6	Y6	Y6	Y6	Y6	Y6
Y7 (MSB)	Y7	Y7	Y7	Y7	Y7	Y7
UV0 (LSB)	U0	V0	U0	V0	U0	V0
UV1	U1	V1	U1	V1	U1	V1
UV2	U2	V2	U2	V2	U2	V2
UV3	U3	V3	U3	V3	U3	V3
UV4	U4	V4	U4	V4	U4	V4
UV5	U5	V5	U5	V5	U5	V5
UV6	U6	V6	U6	V6	U6	V6
UV7(MSB)	U7	V7	U7	V7	U7	V7
Y frame	0	1	2	3	4	5
UV frame	0		2		4	

# Video enhancement and D/A processor (VEDA2)

SAA7165

### Interpolation

The chrominance interpolation filter consists of various filter stages, multiplexers and de-multiplexers to increase the data rate of the colour-difference signals by a factor of 2 or 4. The switching of the filters by the bits IFF, IFC and IFL is described previously. Additional signal samples with significant amplitudes between two consecutive signal samples of the low data rate are generated. The time-multiplexed U and V samples are stored in parallel for converting.

### Data switch

The digital signals are adapted to the conversation range. U and V data have 8-bit formats again; Y can have 9 bits dependent on peaking. Blanking and switching to colourless level is applied here. Bits can be inverted by INV-bit to change the polarity of colour-difference output signals.

### Digital colour transient improvement (DCTI)

The DCTI circuit improves the transition behaviour of the UV colour-difference signals. As the CVBS signal allows for a 4 : 1 : 1 bandwidth representation only, the DCTI improves the transients to the same performance as signals coming from a 4 : 2 : 2 source – or even more.

In order to obtain the point of inflection, the second derivative of the signal is calculated. The improved transition is centered with respect to the point of inflection of the original signal. Thus, there is no horizontal shift of the resulting signal.

The transition area length to be improved is controlled via I<sup>2</sup>C-bus by the bits LI1 and LI0 (Table 4); the sensitivity of the DCTI block is controlled by the bits GA1 and GA0. The CMO bit controls the colour detail sensitivity. It should be set to 1

(ON) if the video signal contains fine colour details (recommended operation mode).

### Digital-to-analog converters

Conversion is separate for Y, U and V. The converters use resistor chains with low-impedance output buffers. The minimum output voltage is 200 mV to reduce integral non-linearity errors. The analog signal, without load on output pin, is between 0.2 and 2.2 V floating. An application for 1 V/75 Ω on outputs is shown in Fig.1.

Each digital-to-analog converter has its own supply and ground pins suitable for decoupling. The reference voltage, supplying the resistor chain of all three DACs, is the supply voltage V<sub>DDA4</sub>. The current into pin 41 is 0.3 mA; a larger current improves the bandwidth but increases the integral non-linearity.

Table 3 Data format 4 : 1 : 1

INPUT	PIXEL BYTE SEQUENCE							
Y0	Y0	Y0	Y0	Y0	Y0	Y0	Y0	Y0
Y1	Y1	Y1	Y1	Y1	Y1	Y1	Y1	Y1
Y2	Y2	Y2	Y2	Y2	Y2	Y2	Y2	Y2
Y3	Y3	Y3	Y3	Y3	Y3	Y3	Y3	Y3
Y4	Y4	Y4	Y4	Y4	Y4	Y4	Y4	Y4
Y5	Y5	Y5	Y5	Y5	Y5	Y5	Y5	Y5
Y6	Y6	Y6	Y6	Y6	Y6	Y6	Y6	Y6
Y7	Y7	Y7	Y7	Y7	Y7	Y7	Y7	Y7
UV0	0	0	0	0	0	0	0	0
UV1	0	0	0	0	0	0	0	0
UV2	0	0	0	0	0	0	0	0
UV3	0	0	0	0	0	0	0	0
UV4	V6	V4	V2	V0	V6	V4	V2	V0
UV5	V7	V5	V3	V1	V7	V5	V3	V1
UV6	U6	U4	U2	U0	U6	U4	U2	U0
UV7	U7	U5	U3	U1	U7	U5	U3	U1
Y frame	0	1	2	3	4	5	6	7
UV frame	0			4				

# Video enhancement and D/A processor (VEDA2)

SAA7165

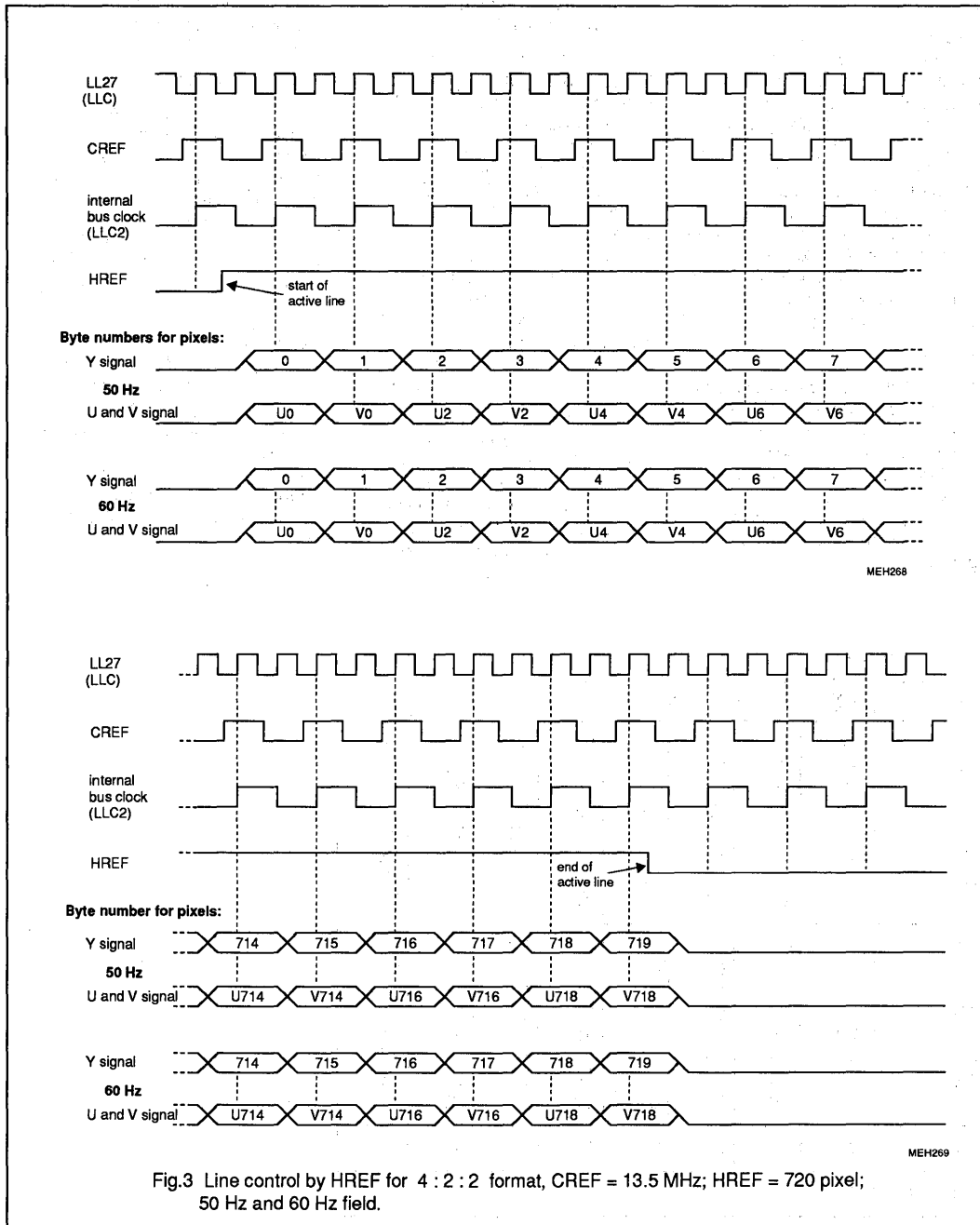

Fig.3 Line control by HREF for 4 : 2 : 2 format, CREF = 13.5 MHz; HREF = 720 pixel; 50 Hz and 60 Hz field.

# Video enhancement and D/A processor (VEDA2)

SAA7165

**LIMITING VALUES**

In accordance with the Absolute Maximum Rating System (IEC 134).

SYMBOL	PARAMETER	MIN.	MAX.	UNIT
V <sub>DD1</sub>	supply voltage range (pin 12)	-0.3	7	V
V <sub>DD2</sub>	supply voltage range (pin 31)	-0.3	7	V
V <sub>DDA1</sub>	supply voltage range (pin 32)	-0.3	7	V
V <sub>DDA2</sub>	supply voltage range (pin 37)	-0.3	7	V
V <sub>DDA3</sub>	supply voltage range (pin 40)	-0.3	7	V
V <sub>DDA4</sub>	supply voltage range (pin 42)	-0.3	7	V
V <sub>diff GND</sub>	difference voltage V <sub>SSD</sub> - V <sub>SSA</sub>	-	±100	mV
V <sub>n</sub>	voltage on all input pins 4 to 11, 14 to 27 and 41	-0.3	V <sub>DD</sub>	V
V <sub>n</sub>	voltage on analog output pins 33, 36 and 39	-0.3	V <sub>DD</sub>	V
P <sub>tot</sub>	total power dissipation	0	tbw	mW
T <sub>stg</sub>	storage temperature range	-55	150	°C
T <sub>amb</sub>	operating ambient temperature range	0	70	°C
V <sub>ESD</sub>	electrostatic handling* for all pins	±2000	-	V

\* Equivalent to discharging a 100 pF capacitor through a 1.5 kΩ series resistor.

**THERMAL RESISTANCE**

SYMBOL	PARAMETER	THERMAL RESISTANCE
R <sub>th j-a</sub>	from junction-to-ambient in free air	46 K/W

# Video enhancement and D/A processor (VEDA2)

SAA7165

**CHARACTERISTICS**

$V_{DD} = 4.5$  to  $5.5$  V;  $V_{DDA} = 4.75$  to  $5.25$  V; LLC = LL27; MC = CREF = 13.5 MHz;  $T_{amb} = 0$  to  $70$  °C; measurements taken in Fig.1 unless otherwise specified.

SYMBOL	PARAMETER	CONDITIONS	MIN.	TYP.	MAX.	UNIT
$V_{DD1}$	supply voltage range (pin 12)	for digital part	4.5	5	5.5	V
$V_{DD2}$	supply voltage range (pin 31)	for digital part	4.5	5	5.5	V
$V_{DDA1}$	supply voltage range (pin 32)	for buffer of DAC 1	4.75	5	5.25	V
$V_{DDA2}$	supply voltage range (pin 37)	for buffer of DAC 2	4.75	5	5.25	V
$V_{DDA3}$	supply voltage range (pin 40)	for buffer of DAC 3	4.75	5	5.25	V
$V_{DDA4}$	supply voltage range (pin 42)	DAC reference voltage	4.75	5	5.25	V
$I_{DD}$	supply current ( $I_{DD1} + I_{DD2}$ )	for digital part	-	tbf	tbf	mA
$I_{DDA}$	supply current ( $I_{DDA1}$ to $I_{DDA4}$ )	for DACs and buffers	-	tbf	tbf	mA
<b>YUV-bus inputs</b> (pins 4 to 11 and 14 to 21)		Figures 3 and 4				
$V_{IL}$	input voltage LOW		-0.5	-	0.8	V
$V_{IH}$	input voltage HIGH		2.0	-	$V_{DD}+0.5$	V
$C_I$	input capacitance	$V_I = \text{HIGH}$	-	-	10	pF
$I_{LI}$	input leakage current		-	-	4.5	$\mu\text{A}$
<b>Inputs MS1, MS2, MC, LLC, HREF and RESN</b> (pins 22 to 27)						
$V_{IL}$	input voltage LOW		-0.5	-	0.8	V
$V_{IH}$	input voltage HIGH		2.0	-	$V_{DD}+0.5$	V
$C_I$	input capacitance	$V_I = \text{HIGH}$	-	-	10	pF
$I_{LI}$	input leakage current		-	-	4.5	$\mu\text{A}$
$V_{24}$	MC input voltage for LL27	27 MHz data rate	2.0	-	$V_{DD}+0.5$	V
	CREF signal on MC input	CREF data rate; note 1	-	-	-	V
<b>I<sup>2</sup>C-bus SCL and SDA</b> (pins 28 and 29)						
$V_{IL}$	input voltage LOW		-0.5	-	1.5	V
$V_{IH}$	input voltage HIGH		3.0	-	$V_{DD}+0.5$	V
$I_I$	input current	$V_I = \text{LOW or HIGH}$	-	-	$\pm 10$	$\mu\text{A}$
$V_{ACK}$	output voltage at acknowledge (pin 29)	$I_{29} = 3$ mA	-	-	0.4	V
$I_{29}$	output current	during acknowledge	3	-	-	mA
<b>Digital-to-analog converters</b> (pins 1, 2, 41, 42, 43 and 44)						
$V_{DAC}$	input reference voltage for internal resistor chains (pin 42)		4.75	5	5.25	V
$I_{CUR}$	input current (pin 41)	$R_{41-42} = 15$ k $\Omega$	-	300	-	$\mu\text{A}$
$V_{1,44}$	reference voltage LOW	pin connected to $V_{SSA1}$	-	0	-	V
$C_L$	external blocking capacitor to $V_{SSA1}$ for reference voltage HIGH (pins 2 and 43)		-	0.1	-	$\mu\text{F}$



# Video enhancement and D/A processor (VEDA2)

SAA7165

SYMBOL	PARAMETER	CONDITIONS	MIN.	TYP.	MAX.	UNIT
$f_{LLC}$	data conversion rate (clock)	Fig.3	-	-	32	MHz
Res	resolution	luminance DAC	-	9	-	bit
		chrominance DACs	-	8	-	bit
ILE	DC integral linearity error	8-bit data	-	-	1.0	LSB
DLE	DC differential error	8-bit data	-	-	0.5	LSB
<b>Y, <math>\pm(R-Y)</math> and <math>\pm(B-Y)</math> analog outputs (pins 39, 33 and 36)</b>						
$V_o$	output signal voltage (peak-to-peak value)	without load	-	2	-	V
$V_{33,36,39}$	output voltage range	without load; note 2	0.2	-	2.2	V
$V_{39}$	output blanking level	Y output; note 3	-	16	-	LSB
$V_{33,36}$	output no-colour level	$\pm(R-Y)$ , $\pm(B-Y)$ ; note 4	-	128	-	LSB
$R_{33,36,39}$	internal serial output resistance		-	25	-	$\Omega$
$R_{L\ 33,36,39}$	output load resistance	external load	125	-	-	$\Omega$
B	output signal bandwidth	-3 dB	20	-	-	MHz
$t_d$	signal delay from input to Y output		-	tbf	-	ns
<b>LLC timing (pins 25)</b> LLC; Fig.3						
$t_{LLC}$	cycle time		33	37	41	ns
$t_{pH}$	pulse width		40	50	60	%
$t_r$	rise time		-	-	5	ns
$t_f$	fall time		-	-	6	ns
<b>YUV-bus timing (pins 4 to 11 and 14 to 21)</b> Fig.5						
$t_{SU}$	input data set-up time		11	-	-	ns
$t_{HD}$	input data hold time		3	-	-	ns
<b>MC timing (pin24)</b> Fig.5						
$t_{SU}$	input data set-up time		11	-	-	ns
$t_{HD}$	input data hold time		3	-	-	ns
<b>RESN timing (pin 27)</b>						
$t_{SU}$	set-up time after power-on or failure	active LOW; note 5	$4 \times t_{LLC}$	-	-	ns

### Notes to the characteristics

1. YUV-bus data is read at MC = HIGH (pin 24) clocked with LLC (Fig.5) . Data is read only with every second rising edge of LLC when CREF = LLC/2 on MC-pin 24.
2. 0.2 to 2.2 V output voltage range at 8-bit DAC input data. The data word can increase to 9-bit dependent on peaking factor.
3. The luminance signal is set to the digital black level: 16 LSB for BLV-bit = 0; 0 LSB for BLV-bit = 1.
4. The chrominance amplitudes are set to the digital colourless level of 128 LSB.
5. The circuit is prepared for a new data initialization.

Video enhancement  
and D/A processor (VEDA2)

SAA7165

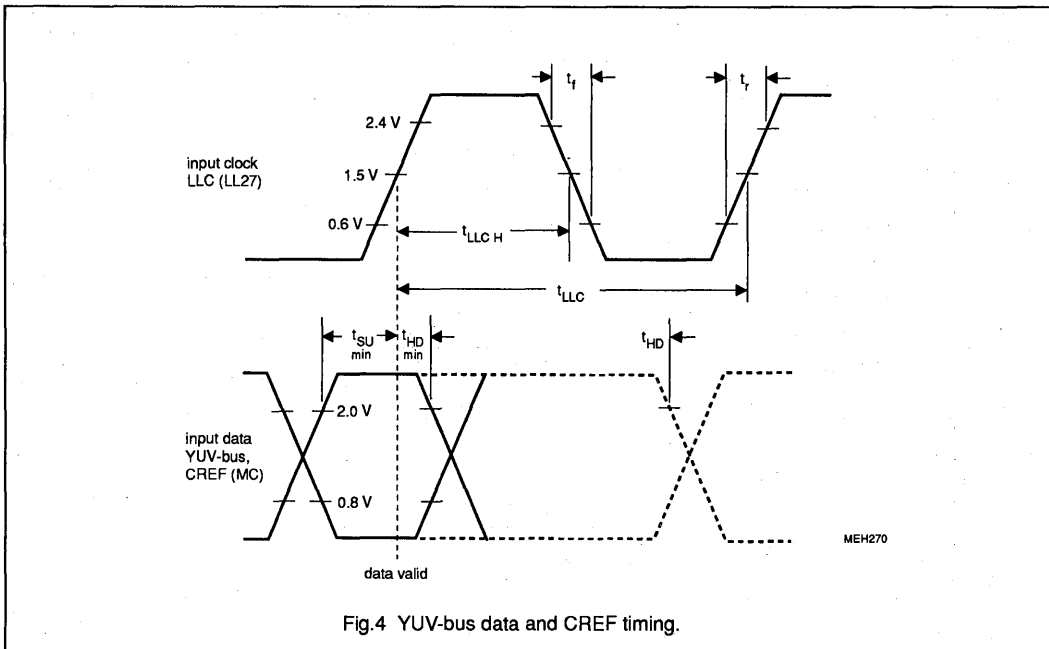

Fig.4 YUV-bus data and CREF timing.

PROCESSING DELAY	LLC CYCLES	REMARKS
YUV digital input to	66	at MC = "1"
YUV analog output	132	at MC = LLC/2

# Video enhancement and D/A processor (VEDA2)

SAA7165

## I<sup>2</sup>C-BUS FORMAT

S	SLAVE ADDRESS	A	SUBADDRESS	A	DATA0	A	-----	DATA <sub>n</sub>	A	P
---	---------------	---	------------	---	-------	---	-------	-------------------	---	---

S	=	start condition
SLAVE ADDRESS	=	1011 111X
A	=	acknowledge, generated by the slave
SUBADDRESS*	=	subaddress byte (Table 4)
DATA	=	data byte (Table 4)
P	=	stop condition
X	=	read/write control bit
		X = 0, order to write (the circuit is slave receiver)
		X = 1, order to read (the circuit is slave transmitter)

\* If more than 1 byte DATA are transmitted, then auto-increment of the subaddress is performed.

**Table 4** I<sup>2</sup>C-bus transmission

FUNCTION	SUBADDRESS	DATA							
		D7	D6	D5	D4	D3	D2	D1	D0
Peaking and coring	01	AFB	CO1	CO0	BP1	BP0	BFB	WG1	WG0
Input formats; interpolation	02	IFF	IFC	IFL	CMO	LI1	LI0	GA1	GA0
Input/output setting	03	0	0	DC1	DC0	DRP	BLV	R78	INV

Bit functions in data bytes:																																				
"01" CO1 and CO0	Control of coring threshold:																																			
	<table border="1"> <thead> <tr> <th>CO1</th> <th>CO0</th> <th></th> </tr> </thead> <tbody> <tr> <td>0</td> <td>0</td> <td>coring off</td> </tr> <tr> <td>0</td> <td>1</td> <td>small noise reduction</td> </tr> <tr> <td>1</td> <td>0</td> <td>medium noise reduction</td> </tr> <tr> <td>1</td> <td>1</td> <td>high noise reduction</td> </tr> </tbody> </table>	CO1	CO0		0	0	coring off	0	1	small noise reduction	1	0	medium noise reduction	1	1	high noise reduction																				
CO1	CO0																																			
0	0	coring off																																		
0	1	small noise reduction																																		
1	0	medium noise reduction																																		
1	1	high noise reduction																																		
AFB, BP1, BP0, BFB	Bandpass filter selection:																																			
	<table border="1"> <thead> <tr> <th>AFB</th> <th>BP1</th> <th>BP0</th> <th>BFB</th> <th></th> </tr> </thead> <tbody> <tr> <td>X</td> <td>0</td> <td>0</td> <td>0</td> <td>characteristic Fig.5</td> </tr> <tr> <td>X</td> <td>0</td> <td>1</td> <td>0</td> <td>characteristic Fig.6</td> </tr> <tr> <td>X</td> <td>1</td> <td>0</td> <td>0</td> <td>characteristic Fig.7</td> </tr> <tr> <td>X</td> <td>1</td> <td>1</td> <td>0</td> <td>characteristic Fig.8</td> </tr> <tr> <td>0</td> <td>X</td> <td>X</td> <td>1</td> <td>BF1 filter bypassed Fig.9(a)</td> </tr> <tr> <td>1</td> <td>X</td> <td>X</td> <td>1</td> <td>BF1 filter bypassed Fig.9(b)</td> </tr> </tbody> </table>	AFB	BP1	BP0	BFB		X	0	0	0	characteristic Fig.5	X	0	1	0	characteristic Fig.6	X	1	0	0	characteristic Fig.7	X	1	1	0	characteristic Fig.8	0	X	X	1	BF1 filter bypassed Fig.9(a)	1	X	X	1	BF1 filter bypassed Fig.9(b)
AFB	BP1	BP0	BFB																																	
X	0	0	0	characteristic Fig.5																																
X	0	1	0	characteristic Fig.6																																
X	1	0	0	characteristic Fig.7																																
X	1	1	0	characteristic Fig.8																																
0	X	X	1	BF1 filter bypassed Fig.9(a)																																
1	X	X	1	BF1 filter bypassed Fig.9(b)																																

Video enhancement  
and D/A processor (VEDA2)

SAA7165

BFB, WG1 and WG0	Peaking factor K:	<table border="1"> <thead> <tr> <th>BFB</th> <th>WG1</th> <th>WG0</th> </tr> </thead> <tbody> <tr><td>0</td><td>0</td><td>0</td></tr> <tr><td>0</td><td>0</td><td>1</td></tr> <tr><td>0</td><td>1</td><td>0</td></tr> <tr><td>0</td><td>1</td><td>1</td></tr> <tr><td>1</td><td>0</td><td>0</td></tr> <tr><td>1</td><td>0</td><td>1</td></tr> <tr><td>1</td><td>1</td><td>0</td></tr> <tr><td>1</td><td>1</td><td>1</td></tr> </tbody> </table>	BFB	WG1	WG0	0	0	0	0	0	1	0	1	0	0	1	1	1	0	0	1	0	1	1	1	0	1	1	1	<table border="1"> <tbody> <tr><td>K = 1/8; minimum peaking</td></tr> <tr><td>K = 1/4</td></tr> <tr><td>K = 1/2</td></tr> <tr><td>K = 1; maximum peaking</td></tr> <tr><td>K = 0; peaking off</td></tr> <tr><td>K = 1/4; minimum peaking</td></tr> <tr><td>K = 1/2</td></tr> <tr><td>K = 1; maximum peaking</td></tr> </tbody> </table>	K = 1/8; minimum peaking	K = 1/4	K = 1/2	K = 1; maximum peaking	K = 0; peaking off	K = 1/4; minimum peaking	K = 1/2	K = 1; maximum peaking
BFB	WG1	WG0																																				
0	0	0																																				
0	0	1																																				
0	1	0																																				
0	1	1																																				
1	0	0																																				
1	0	1																																				
1	1	0																																				
1	1	1																																				
K = 1/8; minimum peaking																																						
K = 1/4																																						
K = 1/2																																						
K = 1; maximum peaking																																						
K = 0; peaking off																																						
K = 1/4; minimum peaking																																						
K = 1/2																																						
K = 1; maximum peaking																																						
"02" IFF, IFC, IFL	Input format and filter control at 13.5 MHz data rate:	<table border="1"> <thead> <tr> <th>IFF</th> <th>IFC</th> <th>IFL</th> </tr> </thead> <tbody> <tr><td>0</td><td>0</td><td>0</td></tr> <tr><td>0</td><td>0</td><td>1</td></tr> <tr><td>0</td><td>1</td><td>X</td></tr> <tr><td>1</td><td>0</td><td>0</td></tr> <tr><td>1</td><td>0</td><td>1</td></tr> <tr><td>1</td><td>1</td><td>X</td></tr> </tbody> </table>	IFF	IFC	IFL	0	0	0	0	0	1	0	1	X	1	0	0	1	0	1	1	1	X	<table border="1"> <tbody> <tr><td>4 : 1 : 1 format; -3 dB attenuation at 1.6 MHz video frequency; Fig.10</td></tr> <tr><td>4 : 1 : 1 format; -3 dB attenuation at 600 kHz video frequency; Fig.11</td></tr> <tr><td>4 : 1 : 1 format; -3 dB attenuation at 1.2 MHz video frequency; Fig.12</td></tr> <tr><td>4 : 2 : 2 format; -3 dB attenuation at 1.6 MHz video frequency; Fig.10</td></tr> <tr><td>4 : 2 : 2 format; -3 dB attenuation at 600 kHz video frequency; Fig.11</td></tr> <tr><td>4 : 2 : 2 format; -3 dB attenuation at 2.5 MHz video frequency; Fig.13</td></tr> </tbody> </table>	4 : 1 : 1 format; -3 dB attenuation at 1.6 MHz video frequency; Fig.10	4 : 1 : 1 format; -3 dB attenuation at 600 kHz video frequency; Fig.11	4 : 1 : 1 format; -3 dB attenuation at 1.2 MHz video frequency; Fig.12	4 : 2 : 2 format; -3 dB attenuation at 1.6 MHz video frequency; Fig.10	4 : 2 : 2 format; -3 dB attenuation at 600 kHz video frequency; Fig.11	4 : 2 : 2 format; -3 dB attenuation at 2.5 MHz video frequency; Fig.13								
IFF	IFC	IFL																																				
0	0	0																																				
0	0	1																																				
0	1	X																																				
1	0	0																																				
1	0	1																																				
1	1	X																																				
4 : 1 : 1 format; -3 dB attenuation at 1.6 MHz video frequency; Fig.10																																						
4 : 1 : 1 format; -3 dB attenuation at 600 kHz video frequency; Fig.11																																						
4 : 1 : 1 format; -3 dB attenuation at 1.2 MHz video frequency; Fig.12																																						
4 : 2 : 2 format; -3 dB attenuation at 1.6 MHz video frequency; Fig.10																																						
4 : 2 : 2 format; -3 dB attenuation at 600 kHz video frequency; Fig.11																																						
4 : 2 : 2 format; -3 dB attenuation at 2.5 MHz video frequency; Fig.13																																						
CMO	Choice modulation:	0 = modulation off; 1 = modulation on																																				
LI1 and LI0	DCTI timing range:	<table border="1"> <thead> <tr> <th>LI1</th> <th>LI0</th> </tr> </thead> <tbody> <tr><td>0</td><td>0</td></tr> <tr><td>0</td><td>1</td></tr> <tr><td>1</td><td>0</td></tr> <tr><td>1</td><td>1</td></tr> </tbody> </table>	LI1	LI0	0	0	0	1	1	0	1	1	<table border="1"> <thead> <tr> <th>range</th> </tr> </thead> <tbody> <tr><td>+4 / -4</td></tr> <tr><td>+6 / -6</td></tr> <tr><td>+8 / -8</td></tr> <tr><td>+12 / -12</td></tr> </tbody> </table>	range	+4 / -4	+6 / -6	+8 / -8	+12 / -12																				
LI1	LI0																																					
0	0																																					
0	1																																					
1	0																																					
1	1																																					
range																																						
+4 / -4																																						
+6 / -6																																						
+8 / -8																																						
+12 / -12																																						
GA1 and GA0	DCTI gain factor:	<table border="1"> <thead> <tr> <th>GA1</th> <th>GA0</th> </tr> </thead> <tbody> <tr><td>0</td><td>0</td></tr> <tr><td>0</td><td>1</td></tr> <tr><td>1</td><td>0</td></tr> <tr><td>1</td><td>1</td></tr> </tbody> </table>	GA1	GA0	0	0	0	1	1	0	1	1	<table border="1"> <thead> <tr> <th>factor</th> </tr> </thead> <tbody> <tr><td>off</td></tr> <tr><td>1/4</td></tr> <tr><td>1/2</td></tr> <tr><td>1</td></tr> </tbody> </table>	factor	off	1/4	1/2	1																				
GA1	GA0																																					
0	0																																					
0	1																																					
1	0																																					
1	1																																					
factor																																						
off																																						
1/4																																						
1/2																																						
1																																						
"03" DC1 and DC0	Delay compensation of luminance signal:	<table border="1"> <thead> <tr> <th>DC1</th> <th>DC0</th> </tr> </thead> <tbody> <tr><td>0</td><td>0</td></tr> <tr><td>0</td><td>1</td></tr> <tr><td>1</td><td>0</td></tr> <tr><td>1</td><td>1</td></tr> </tbody> </table>	DC1	DC0	0	0	0	1	1	0	1	1	<table border="1"> <thead> <tr> <th>delayed clock cycles</th> </tr> </thead> <tbody> <tr><td>0</td></tr> <tr><td>+1</td></tr> <tr><td>-2</td></tr> <tr><td>-1</td></tr> </tbody> </table>	delayed clock cycles	0	+1	-2	-1																				
DC1	DC0																																					
0	0																																					
0	1																																					
1	0																																					
1	1																																					
delayed clock cycles																																						
0																																						
+1																																						
-2																																						
-1																																						

**Video enhancement  
and D/A processor (VEDA2)****SAA7165**

DRP	UV input data code:	0 = two's complement; 1 = offset binary
BLV	Blanking level on Y output:	0 = 16 LSB; 1 = 0 LSB
R78	YUV input data solution:	0 = 7-bit data; 1 = 8-bit data
INV	Polarity of colour-difference output signals:	0 = normal polarity equal to input signal 1 = inverted polarity

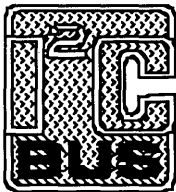

Purchase of Philips' I<sup>2</sup>C components conveys a license under the Philips' I<sup>2</sup>C patent to use the components in the I<sup>2</sup>C-system provided the system conforms to the I<sup>2</sup>C specifications defined by Philips.

Video enhancement  
and D/A processor (VEDA2)

SAA7165

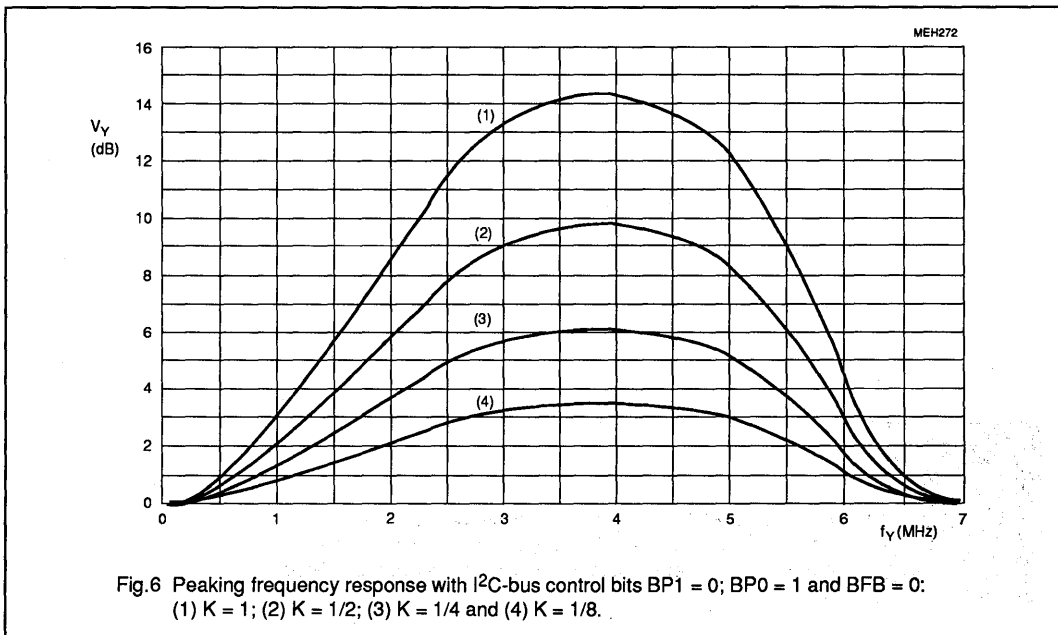
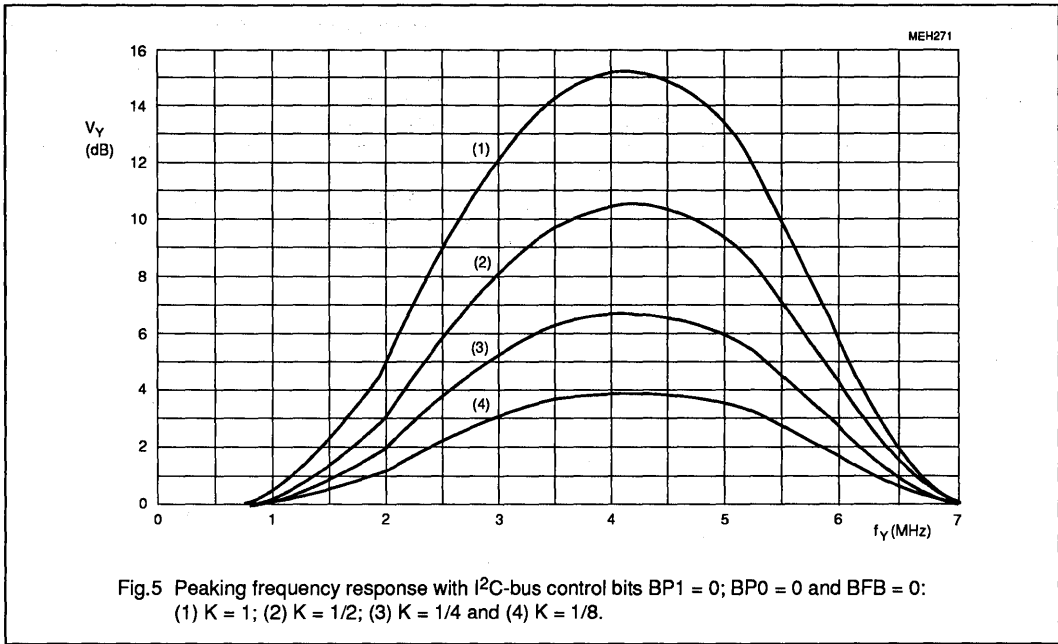

# Video enhancement and D/A processor (VEDA2)

SAA7165

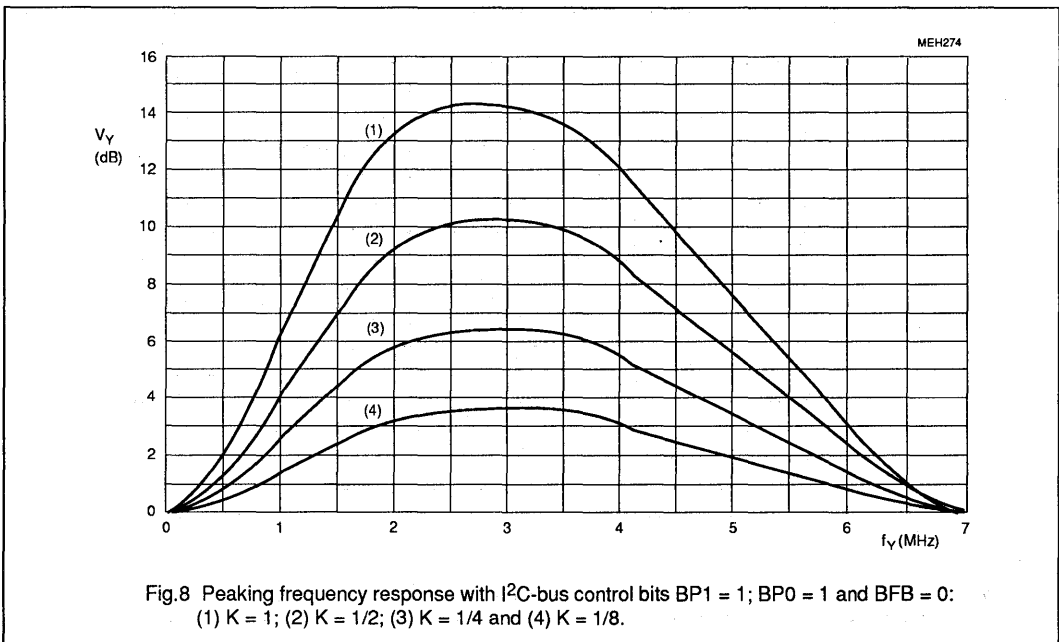
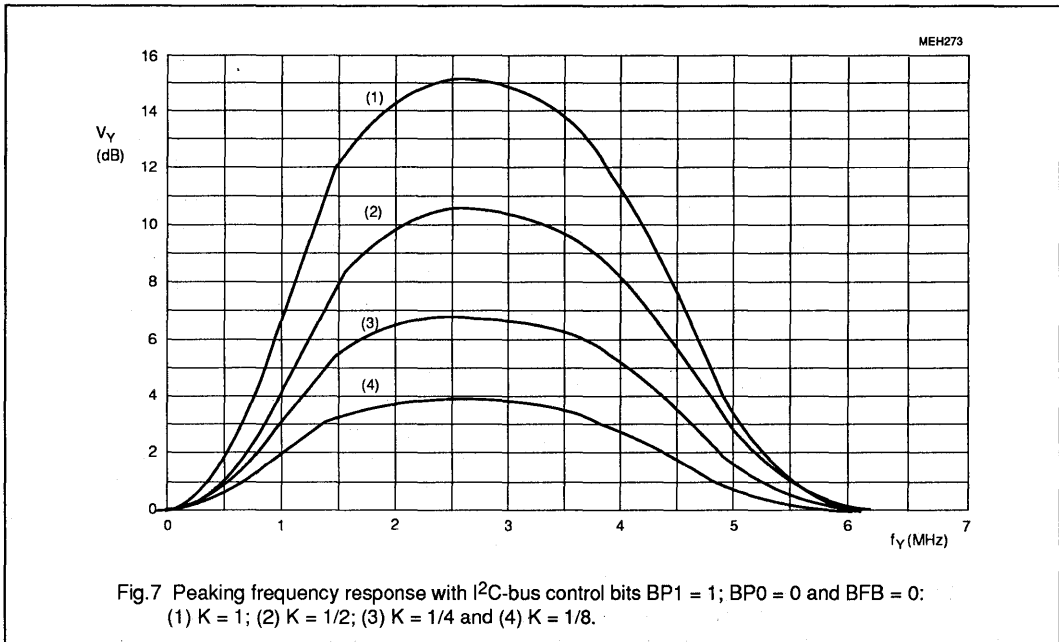

Video enhancement  
and D/A processor (VEDA2)

SAA7165

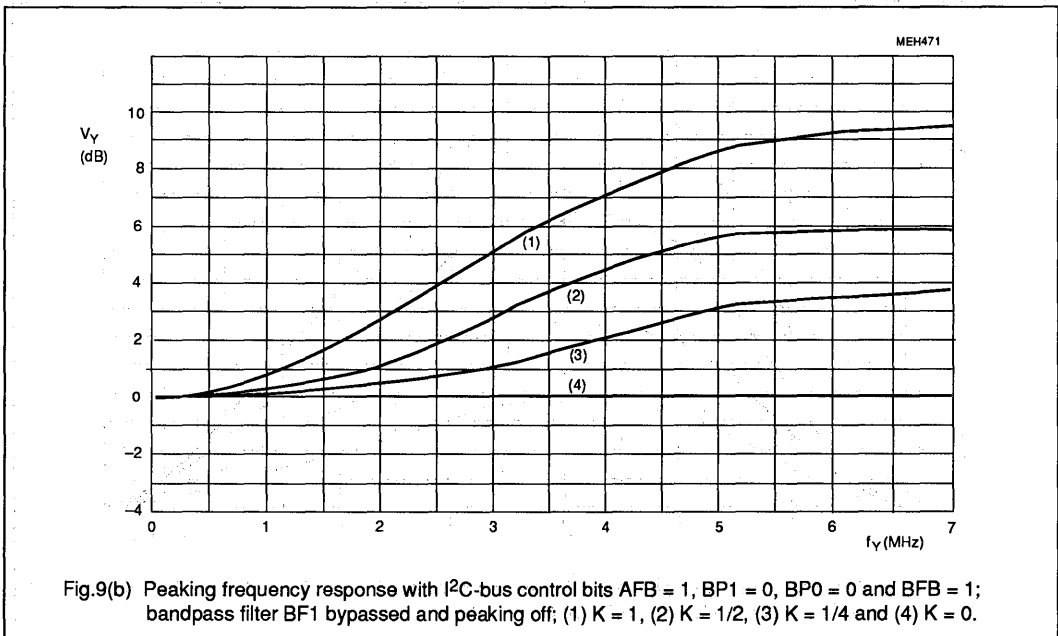
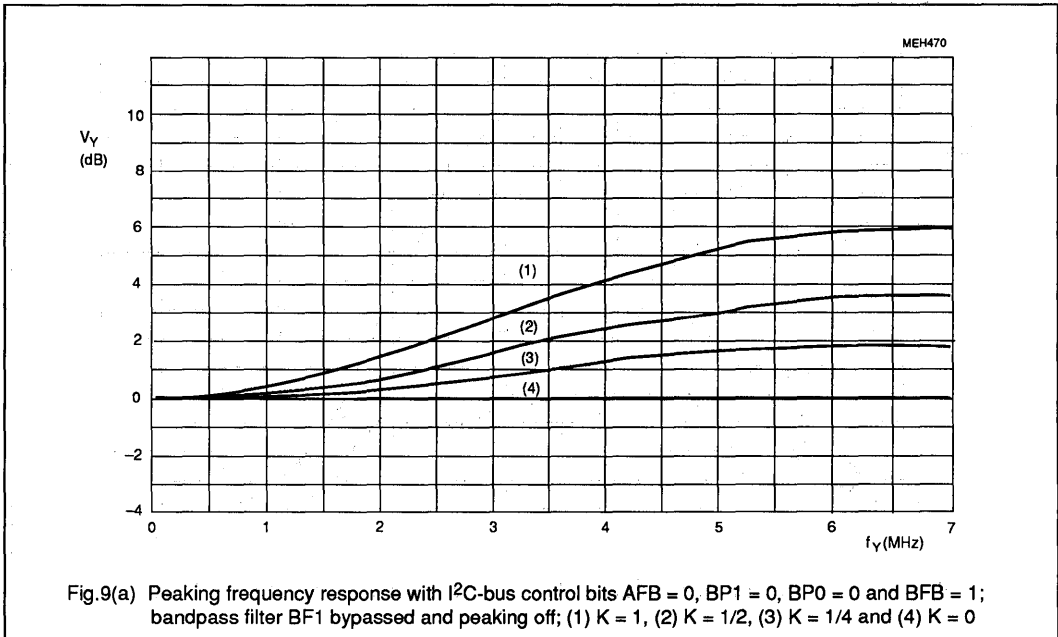



# Video enhancement and D/A processor (VEDA2)

SAA7165

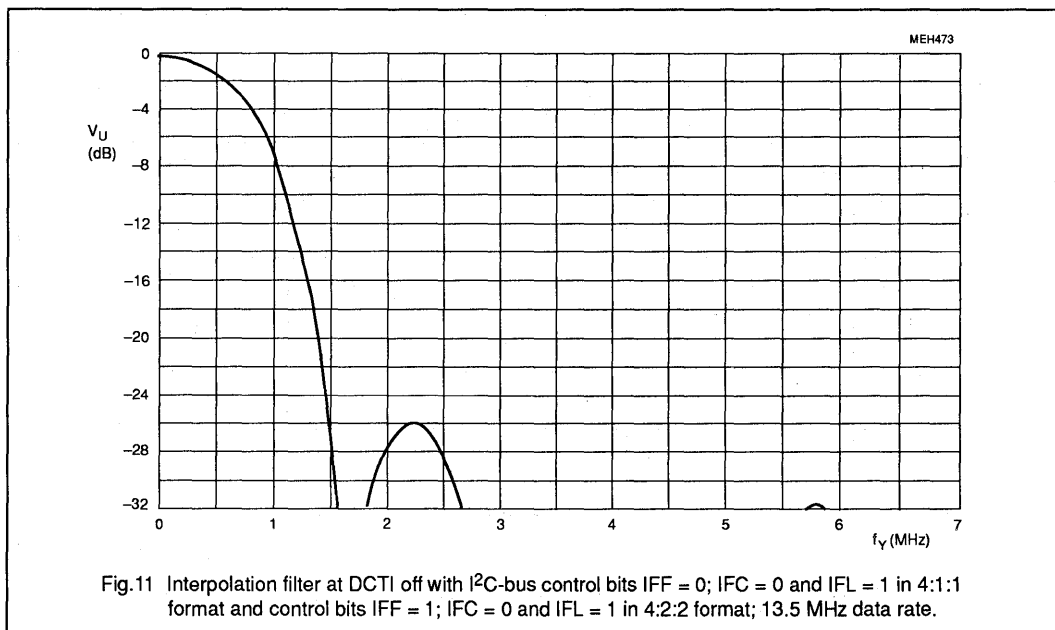
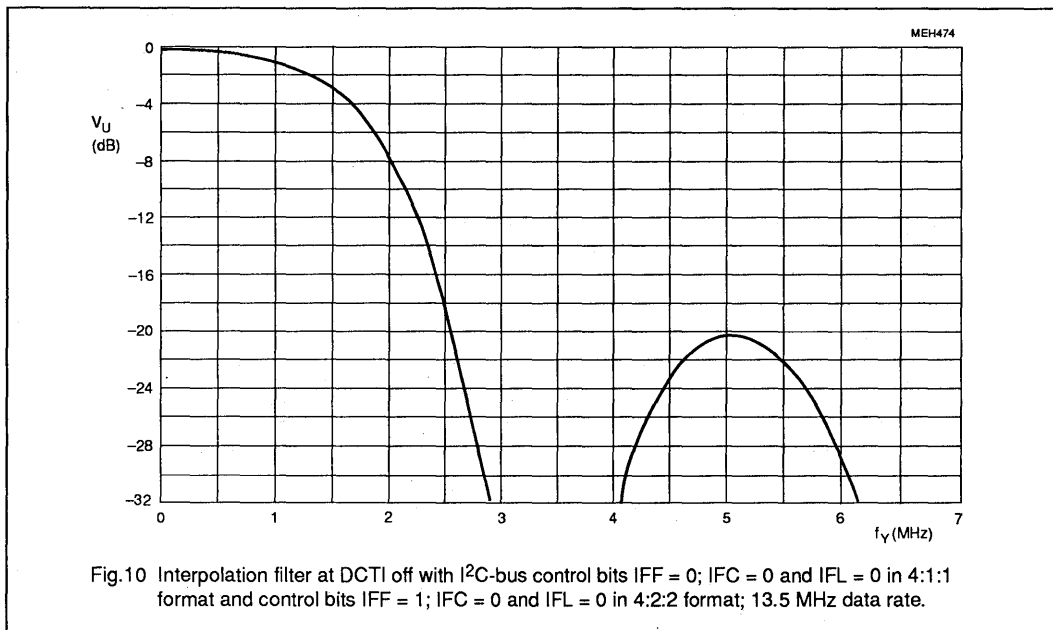

# Video enhancement and D/A processor (VEDA2)

SAA7165

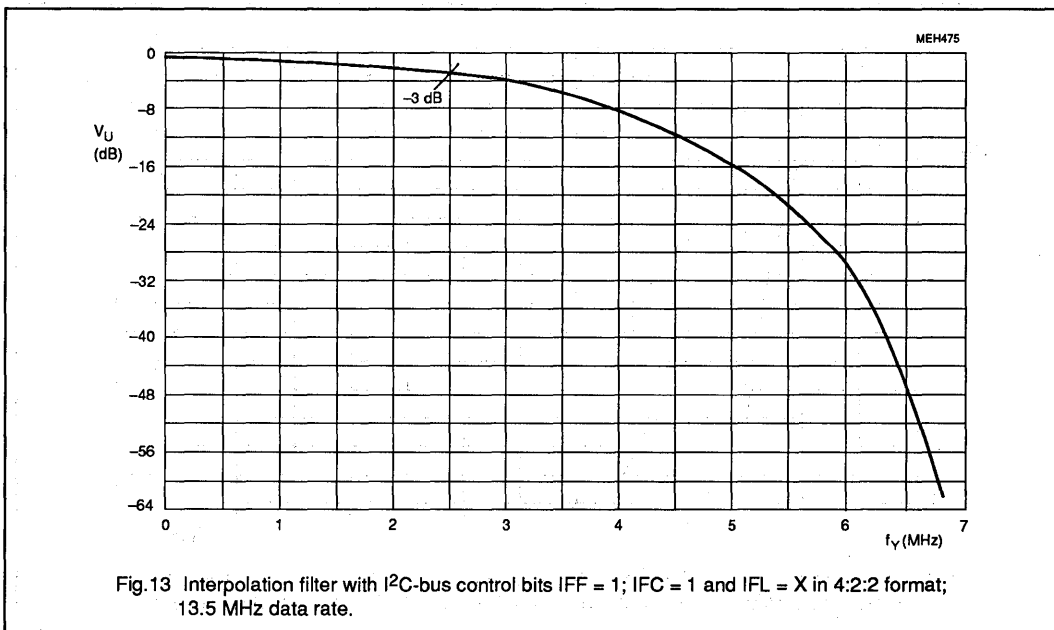
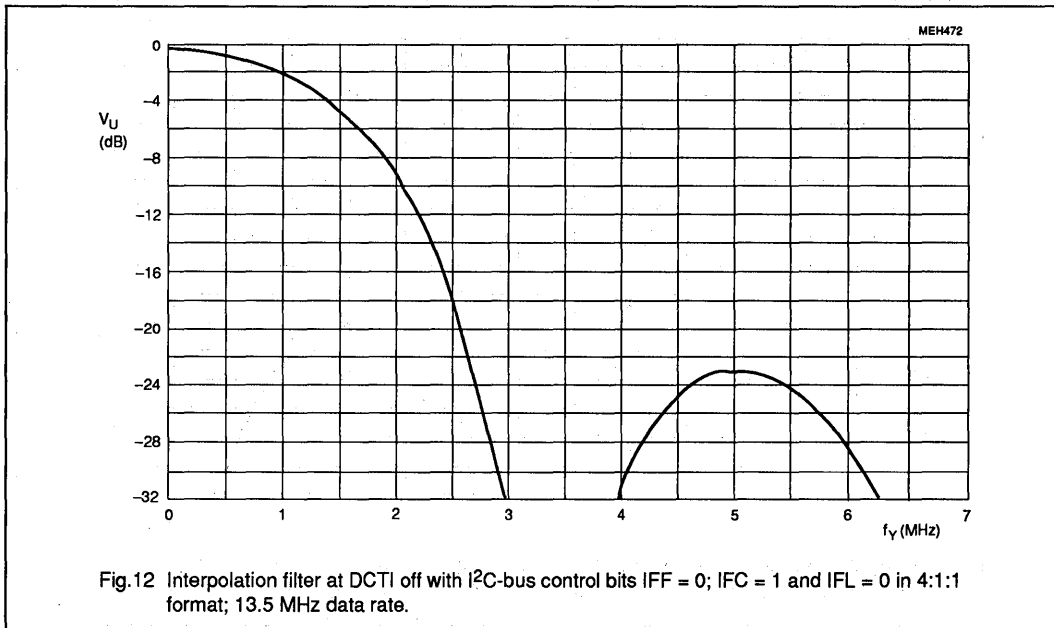

# 35 MHz triple 9-bit D/A converter for high-speed video

SAA7169

## FEATURES

- CMOS circuit to convert high-speed video data from digital to analog
- Three equal 9-bit digital-to-analog converters
- Input signals TTL-compatible
- Input registers for positive edge-triggered data signals
- Clock frequency for a conversion rate up to 35 MHz
- 20 MHz analog bandwidth
- 2 V (p-p) analog output voltage range without load on output (0.2 to 2.2 V DC)
- 1 V / 75  $\Omega$  outputs (0.1 to 1.1 V DC); Fig.1
- No de-glitching circuit required
- Typical 225 mW power dissipation

## GENERAL DESCRIPTION

The triple high-speed D/A converter can be used in applications for

- desktop video processing
- digital television
- graphic displays
- television decoders
- general high frequency conversion

## QUICK REFERENCE DATA

SYMBOL	PARAMETER	MIN.	TYP.	MAX.	UNIT
$V_{DD}$	supply voltage digital part	4.5	5	5.5	V
$V_{DDA}$	supply voltage analog part	4.75	5	5.25	V
$I_{DD\ tot}$	total supply current	-	-	38	mA
$V_I$	data input levels	TTL-compatible			
$f_{CLK}$	conversion frequency	1	-	35	MHz
$V_o$	nominal output amplitude on pins 1, 3, 43 (peak-to-peak value)	-	2	-	V
B	bandwidth (-3 dB)	20	-	-	MHz
DNL	differential non-linearity	-	-	$\pm 0.5$	LSB
INL	integral non-linearity	-	-	$\pm 0.2$	%
$\alpha_{CR}$	crosstalk attenuation	48	-	-	dB
$R_o$	internal serial output resistance	-	25	-	$\Omega$
$R_L$	output load resistance	125	-	-	$\Omega$
$T_{amb}$	operating ambient temperature range	0	-	70	$^{\circ}C$

## ORDERING INFORMATION

EXTENDED TYPE NUMBER	PACKAGE			
	PINS	PIN POSITION	MATERIAL	CODE
SAA7169	44	PLCC	plastic	SOT187

**35 MHz triple 9-bit D/A converter  
for high-speed video**

**SAA7169**

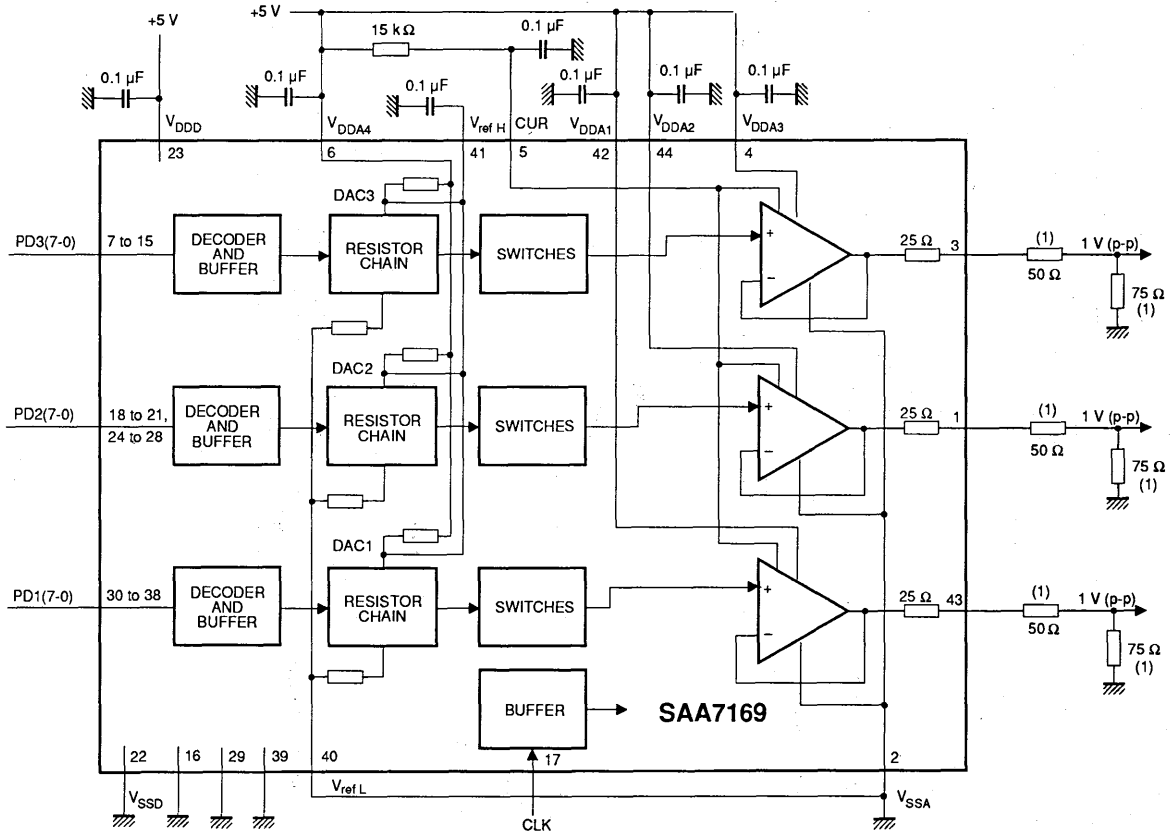

(1) output amplitude determined by resistors ( $R_L > 120 \Omega$ )

MEH331

Fig.1 Block diagram and application circuit.

# 35 MHz triple 9-bit D/A converter for high-speed video

SAA7169

## PINNING

SYMBOL	PIN	DESCRIPTION
$V_{o2}$	1	analog output voltage of channel 2
$V_{SSA}$	2	analog ground (0 V)
$V_{o3}$	3	analog output voltage of channel 3
$V_{DDA3}$	4	+5 V supply voltage for buffer amplifier of channel 3
CUR	5	current input for analog output buffers, decoupled to $V_{SSA}$
$V_{DDA4}$	6	+5 V supply voltage for analog reference part
PD3(8)	7	9-bit data input of channel 3
PD3(7)	8	
PD3(6)	9	
PD3(5)	10	
PD3(4)	11	
PD3(3)	12	
PD3(2)	13	
PD3(1)	14	
PD3(0)	15	
i.c.	16	connect to digital ground (input not used)
CLK	17	clock frequency input
PD2(8)	18	9-bit data input of channel 2 (bits PD2(8-5))
PD2(7)	19	
PD2(6)	20	
PD2(5)	21	
$V_{SSD}$	22	digital ground (0 V)
$V_{DDD}$	23	+5 V supply voltage for digital part
PD2(4)	24	9-bit data input of channel 2 (bits PD2(4-0))
PD2(3)	25	
PD2(2)	26	
PD2(1)	27	
PD2(0)	28	
i.c.	29	connect to digital ground (input not used)
PD1(8)	30	9-bit data input of channel 1 (bits PD1(8-4))
PD1(7)	31	
PD1(6)	32	
PD1(5)	33	
PD1(4)	34	

# 35 MHz triple 9-bit D/A converter for high-speed video

SAA7169

SYMBOL	PIN	DESCRIPTION
PD1(3)	35	9-bit data input of channel 1 (bits PD1(3-0))
PD1(2)	36	
PD1(1)	37	
PD1(0)	38	
i.c.	39	
V <sub>ref L</sub>	40	reference voltage LOW; analog ground (V <sub>SSA</sub> )
V <sub>ref H</sub>	41	internal generated reference voltage HIGH, decoupled to V <sub>SSA</sub>
V <sub>DDA1</sub>	42	+5 V supply voltage for buffer amplifier of channel 1
V <sub>o 1</sub>	43	analog output voltage of channel 1
V <sub>DDA2</sub>	44	+5 V supply voltage for buffer amplifier of channel 2

### PIN CONFIGURATION

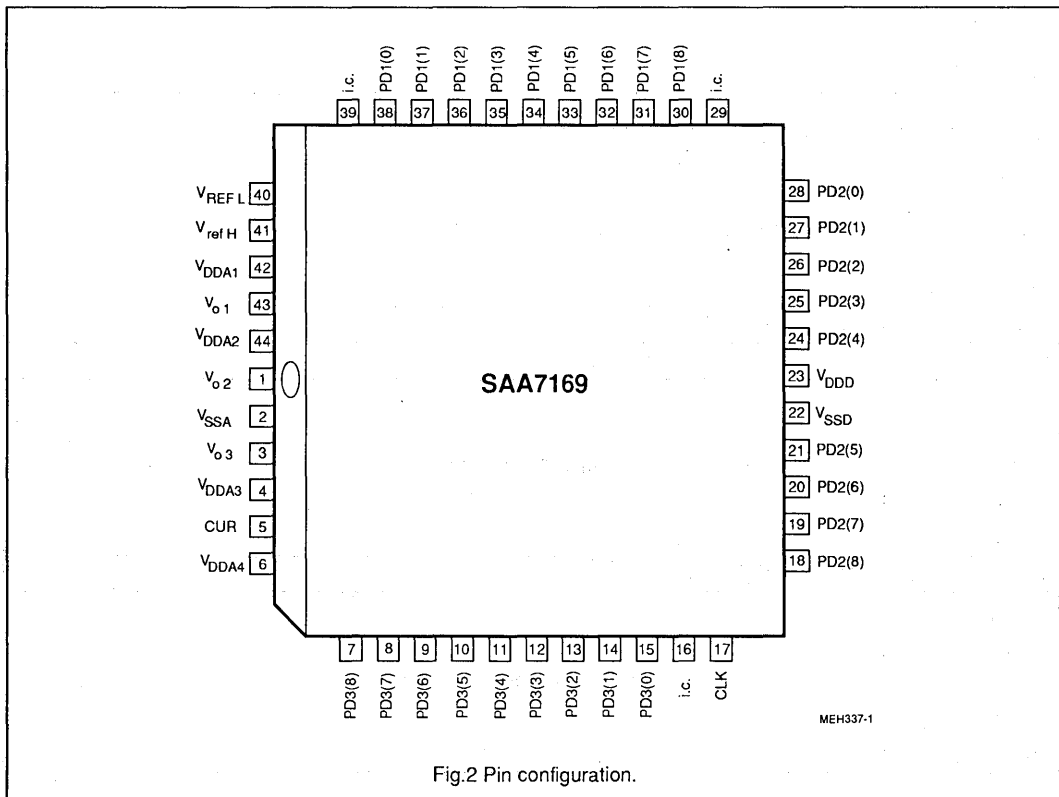

Fig.2 Pin configuration.

## 35 MHz triple 9-bit D/A converter for high-speed video

SAA7169

### FUNCTIONAL DESCRIPTION

The integrated monolithic CMOS circuit SAA7169 is a triple 9-bit digital-to-analog converter for high-speed video applications. Its three channels are equal. The maximum conversion rate is 35 MHz.

The converters use a combination of resistor chains with low-impedance output buffers. The bottom output

voltage is 200 mV to reduce integral non-linearity errors. The analog signal, without load on output pin, is between 0.2 and 2.2 V. Fig.1 shows the application for 1 V/75  $\Omega$  outputs, using the serial 25  $\Omega$  + 50  $\Omega$  resistors.

Each digital-to-analog converter has its own supply pin for purpose of decoupling.  $V_{DDA4}$  is the supply voltage for the resistor chains of the three DACs. The accuracy of this

supply voltage influences directly the output amplitudes.

The current CUR into pin 5 is 0.3 mA ( $V_{DDA4} = 5$  V,  $R_{5-6} = 15$  k $\Omega$ ); a larger current improves the bandwidth but increases the integral non-linearity.

### LIMITING VALUES

In accordance with the Absolute Maximum Rating System (IEC 134).

SYMBOL	PARAMETER	MIN.	MAX.	UNIT
$V_{DDD}$	digital supply voltage range (pin 23)	-0.3	7	V
$V_{DDA1}$	analog supply voltage range (pin 42)	-0.3	7	V
$V_{DDA2}$	analog supply voltage range (pin 44)	-0.3	7	V
$V_{DDA3}$	analog supply voltage range (pin 4)	-0.3	7	V
$V_{DDA4}$	analog supply voltage range (pin 6)	-0.3	7	V
$V_{diff\ GND}$	difference voltage $V_{SSD} - V_{SSA}(1\ to\ 4)$	-	$\pm 100$	mV
$V_n$	voltage on all input pins 7 to 15, 18 to 21 and 24 to 40	-0.3	$V_{DDD}$	V
$P_{tot}$	total power dissipation	0	tbody	mW
$T_{amb}$	operating ambient temperature range	0	70	$^{\circ}C$
$T_{stg}$	storage temperature range	-65	150	$^{\circ}C$
$V_{ESD}$	electrostatic handling* for all pins	$\pm 2000$	-	V

\* Equivalent to discharging a 100 pF capacitor through a 1.5 k $\Omega$  series resistor.

# 35 MHz triple 9-bit D/A converter for high-speed video

SAA7169

**CHARACTERISTICS**

$V_{DD3} = 4.5$  to  $5.5$  V;  $V_{DDA} = 4.75$  to  $5.25$  V; CLK = 35 MHz;  $f_{DATA} = 17.5$  MHz (squarewave, full scale);  
 $T_{amb} = 0$  to  $70$  °C; measurements taken in Fig.1 unless otherwise specified.

SYMBOL	PARAMETER	CONDITIONS	MIN.	TYP.	MAX.	UNIT
$V_{DD3}$	supply voltage range (pin 23)	for digital part	4.5	5	5.5	V
$V_{DDA1}$	supply voltage range (pin 42)	for buffer of DAC 1	4.75	5	5.25	V
$V_{DDA2}$	supply voltage range (pin 44)	for buffer of DAC 2	4.75	5	5.25	V
$V_{DDA3}$	supply voltage range (pin 4)	for buffer of DAC 3	4.75	5	5.25	V
$V_{DDA4}$	supply voltage range (pin 6)	DAC reference voltage	4.75	5	5.25	V
$I_{DD3}$	supply current	for digital part; note 1	-	-	20	mA
$I_{DDA}$	supply current ( $I_{DDA1}$ to $I_{DDA4}$ )	without load on outputs	-	-	18	mA
<b>9-bit data inputs</b> (pins 7 to 15; 18 to 21, 24 to 28 and 30 to 38)						
$V_{IL}$	input voltage LOW		-0.5	-	0.8	V
$V_{IH}$	input voltage HIGH		2.0	-	$V_{DD3}+0.5$	V
$C_I$	input capacitance		-	-	10	pF
$I_{leak}$	input leakage current		-	-	10	$\mu$ A
$t_{SU}$	data set-up time	Fig.3	11	-	-	ns
$t_{HD}$	data hold time		3	-	-	ns
<b>CLK input</b> (pin 17)			Fig.3			
$f_{CLK}$	frequency range		1	-	35	MHz
$V_{IL}$	input voltage LOW		-0.5	-	0.8	V
$V_{IH}$	input voltage HIGH		2.0	-	$V_{DD3}+0.5$	V
$C_I$	input capacitance		-	-	10	pF
$I_{leak}$	input leakage current		-	-	10	$\mu$ A
$t_{CLK}$	cycle time		28.5	-	-	ns
$t_{pH}$	duty factor	$t_{CLKH} / t_{CLK}$	40	50	60	%
$t_r$	rise time		-	-	5	ns
$t_f$	fall time		-	-	6	ns
<b>Digital-to-analog converters</b> (pins 5, 6 and 40)						
$V_{DDA4}$	reference input voltage for internal resistor chains (pin 6)		4.75	5	5.25	V
$I_{CUR}$	input current (pin 5)	$R_{6-5} = 15$ k $\Omega$	-	-	400	$\mu$ A
<b>Analog outputs <math>V_{O1}</math>; <math>V_{O2}</math> and <math>V_{O3}</math></b> (pins 43, 1 and 3)						
$V_o$	nominal output signal (peak-to-peak value)	without load	-	2	-	V
$V_{43, 1, 3}$	minimum output voltage	without load; $V_{DDA4} = 5$ V	0.16	-	0.24	V
	maximum output voltage	without load; $V_{DDA4} = 5$ V	2.1	-	2.3	V
DTDM	DAC to DAC matching	between all channels	-	-	30	mV



# 35 MHz triple 9-bit D/A converter for high-speed video

SAA7169

SYMBOL	PARAMETER	CONDITIONS	MIN.	TYP.	MAX.	UNIT
B	output signal bandwidth	-3 dB	20	-	-	MHz
$\alpha_{CR}$	crosstalk attenuation	note 2	48	-	-	dB
DNL	differential non-linearity	9-bit data; $R_L = 125 \Omega$	-	-	$\pm 0.5$	LSB
INL	integral non-linearity	9-bit data; $R_L = 125 \Omega$	-	-	$\pm 0.2$	%
$R_{43, 1, 3}$	internal serial output resistor		-	25	-	$\Omega$
$R_{L 43, 1, 3}$	load resistance on output		125	-	-	$\Omega$

**Notes to the characteristics**

1. With  $f_{CLK} = 35 \text{ MHz}$ ;  $f_{DATA} = 17.5 \text{ MHz}$  (squarewave, full scale)
2. Crosstalk from channel to channel. One DAC with digital 5 MHz (sinusoidal, full scale) input signal, the other input data LOW. Measurements taken on outputs with 5.46 MHz filters (-3 dB at 5.87 MHz and -45 dB at 7.24 MHz).

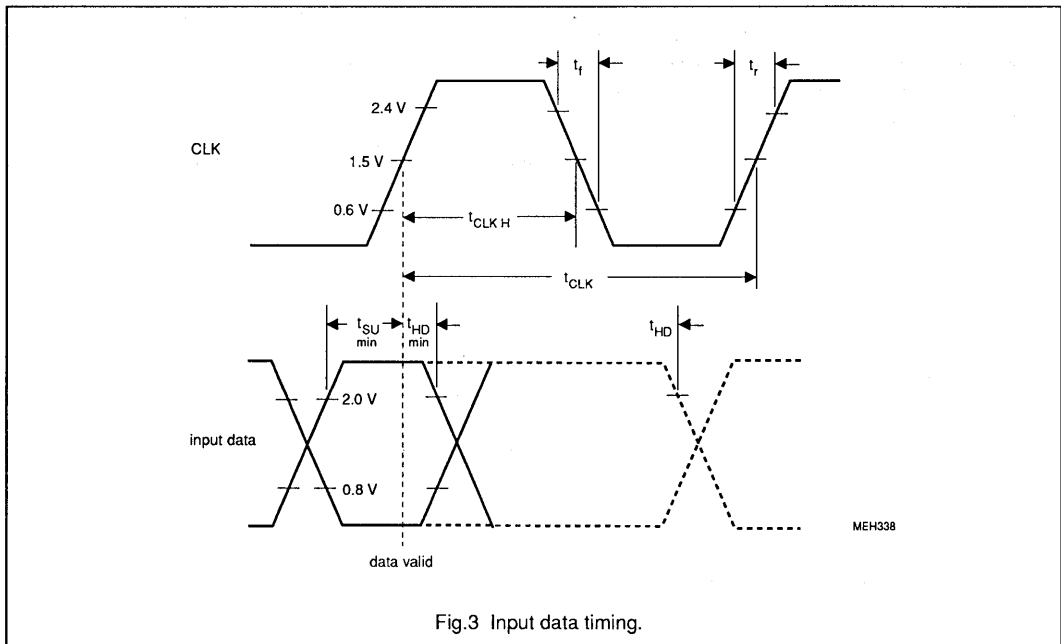

---

## Digital video encoder (square pixel with Macrovision)

---

SAA7183

The SAA7183 Digital Video Encoder is functionally equivalent to the SAA7187. Both the electrical and physical parameters are identical.

The only distinction is that the SAA7183 can be programmed to insert anti-taping encoding (Macrovision) onto the video signal.

Use of Macrovision technology requires a license from Macrovision. Sample request and sales orders require the following procedure:

### Sample Requests

- Contact Bill Krepick, Macrovision  
Phone: (415)691-2900  
Fax: (415)691-2999
- Macrovision will send an NDA to the customer
- Returned signed NDA will be sent to Macrovision and to Monica Howes, Tactical Marketing, Philips Semiconductors  
Fax: (408)991-2133
- Samples will then be sent to the customer

### Sales Orders

- If the customer has a Macrovision license:
  - The customer provides Philips with written confirmation of the license
  - Marketing will retain the written confirmation
  - Customer can then purchase part
- If the customer **does not have a Macrovision license**:
  - The customer must obtain a license or waiver from Macrovision
  - Customer must provide Philips with written confirmation of the license or waiver from Macrovision
  - Marketing retains written information
  - Customer purchases part

Neither parts nor programming information will be sent to the customer until the above conditions are met.

## Digital video scaler

## SAA7186

### 1. FEATURES

- Scaling of video picture windows down to randomly sized windows
- Processes maximum 1023 pixels per line and 1023 lines per field
- Two-dimensional data processing for improved signal quality of scaled video data and for compression of video data
- 16-bit YUV input data buffer
- Interlace/non-interlace video data processing and field control
- Line memories in Y path and UV path to store two lines, each with 2 x 768 x 8 bit capacity
- Vertical sync processing by scale control
- Non-scaled mode to get full picture or to gate videotext lines
- UV input and output data binary/two's complement
- Switchable RGB matrix and anti-gamma ROMs
- 16-word FIFO register for 32-bit output data
- Output formats: 5-bit and 8-bit RGB, 8-bit YUV or 8-bit monochrome

### 2. GENERAL DESCRIPTION

The CMOS circuit SAA7186 scales and filters digital video data to randomly sized picture windows. YUV input data in 4:2:2 format are required (SAA7191B source).

### 3. QUICK REFERENCE DATA

SYMBOL	PARAMETER	MIN.	TYP.	MAX.	UNIT
$V_{DD}$	supply voltage	4.5	5	5.5	V
$I_{DD\ tot}$	total supply current (inputs LOW, without output load)	-	-	180	mA
$V_I$	data input level	TTL-compatible			
$V_O$	data output level	TTL-compatible			
LLC	input clock frequency	-	-	32	MHz
$T_{amb}$	operating ambient temperature range	0	-	70	°C

### 4. ORDERING INFORMATION

EXTENDED TYPE NUMBER	PACKAGE			
	PINS	PIN POSITION	MATERIAL	CODE
SAA7186	100	QFP	plastic	SOT317



## Digital video scaler

SAA7186

## 6. PINNING

SYMBOL	PIN	STATUS	DESCRIPTION
LNQ	1	O	line qualifier signal; active polarity defined by QPL-bit in "10" (VCLK strobed)
HREFD	2	O	delay-compensated HREF output signal (VCLK strobed)
V <sub>SS1</sub>	3	-	GND1 (0 V)
i.c.	4	-	internally connected
V <sub>DD1</sub>	5	-	+5 V supply voltage 1
i.c.	6	-	internally connected
SP	7	I	connected to ground (shift pin for testing)
AP	8	I	connected to ground (action pin for testing)
n.c.	9	-	not connected
UVIN0	10	I	time-multiplexed colour-difference input data (bits 0 to 3)
UVIN1	11	I	
UVIN2	12	I	
UVIN3	13	I	
V <sub>DD2</sub>	14	-	+5 V supply voltage 2
n.c.	15	-	not connected
V <sub>SS2</sub>	16	-	GND2 (0 V)
UVIN4	17	I	time- multiplexed colour-difference input data (bits 4 to 7)
UVIN5	18	I	
UVIN6	19	I	
UVIN7	20	I	
n.c.	21	-	not connected
YIN0	22	I	luminance input data (bits 0 to 3)
YIN1	23	I	
YIN2	24	I	
YIN3	25	I	
V <sub>DD3</sub>	26	-	+5 V supply voltage 3
n.c.	27	-	not connected
V <sub>SS3</sub>	28	-	GND3 (0 V)
n.c.	29	-	not connected
YIN4	30	I	luminance input data (bits 4 to 7)
YIN5	31	I	
YIN6	32	I	
YIN7	33	I	
n.c.	34	-	not connected

## Digital video scaler

SAA7186

SYMBOL	PIN	STATUS	DESCRIPTION
CREF	35	I	clock reference, external sync signal
LLC	36	I	line-locked system clock input signal (twice of pixel rate)
HREF	37	I	horizontal reference, pixel data clock signal (also present during vertical blanking)
VS	38	I	vertical sync input signal (approximately 6 lines long)
n.c.	39	-	not connected
V <sub>DD4</sub>	40	-	+5 V supply voltage 4
n.c.	41	-	not connected
V <sub>SS4</sub>	42	-	GND4 (0 V)
RESN	43	I	reset input (active-LOW for at least 30LLC periods)
SDA	44	I/O	IIC-bus data line
SCL	45	I	IIC-bus clock line
IICSA	46	I	set module address input of IIC-bus (LOW = B8, HIGH = BC)
BTST	47	I	output disable input; HIGH sets all data outputs to high-impedance state
INCADR	48	O	line increment / vertical reset control output line
HFL	49	O	FIFO register half-full flag output
VOEN	50	I	VRAM port output enable input (active-LOW)
VCLK	51	I	FIFO register clock input signal
n.c.	52	-	not connected
V <sub>SS5</sub>	53	-	GND5 (0 V)
n.c.	54	-	not connected
V <sub>DD5</sub>	55	-	+5 V supply voltage 5
VRO31	56	O	video output; 32-bit VRAM output port (bits 31 to 28)
VRO30	57	O	
VRO29	58	O	
VRO28	59	O	
n.c.	60	-	not connected
VRO27	61	O	video output; 32-bit VRAM output port (bits 27 to 24)
VRO26	62	O	
VRO25	63	O	
VRO24	64	O	
V <sub>SS6</sub>	65	-	GND6 (0 V)
n.c.	66	-	not connected
V <sub>DD6</sub>	67	-	+5 V supply voltage 6
VRO23	68	O	video output; 32-bit VRAM output port (bits 23 to 22)
VRO22	69	O	

## Digital video scaler

SAA7186

SYMBOL	PIN	STATUS	DESCRIPTION
VRO21	70	O	video output; 32-bit VRAM output port (bits 21 to 20)
VRO20	71	O	
n.c.	72	-	not connected
VRO19	73	O	video output; 32-bit VRAM output port (bits 19 to 17)
VRO18	74	O	
VRO17	75	O	
V <sub>DD7</sub>	76	-	+5 V supply voltage 7
VRO16	77	O	video output; 32-bit VRAM output port (bit16)
V <sub>SS7</sub>	78	-	GND7 (0 V)
n.c.	79	-	not connected
VRO15	80	O	video output; 32-bit VRAM output port (bits 15 to 12)
VRO14	81	O	
VRO13	82	O	
VRO12	83	O	
n.c.	84	-	not connected
VRO11	85	O	video output; 32-bit VRAM output port (bits 11 to 8)
VRO10	86	O	
VRO9	87	O	
VRO8	88	O	
V <sub>SS8</sub>	89	O	GND8 (0 V)
n.c.	90	-	not connected
V <sub>DD8</sub>	91	-	+5 V supply voltage 8
VRO7	92	O	video output; 32-bit VRAM output port (bits 7 to 4)
VRO6	93	O	
VRO5	94	O	
VRO4	95	O	
n.c.	96	-	not connected
VRO3	97	O	video output; 32-bit VRAM output port (bits 3 to 0)
VRO2	98	O	
VRO1	99	O	
VRO0	100	O	

Digital video scaler

SA A7186

PIN CONFIGURATION

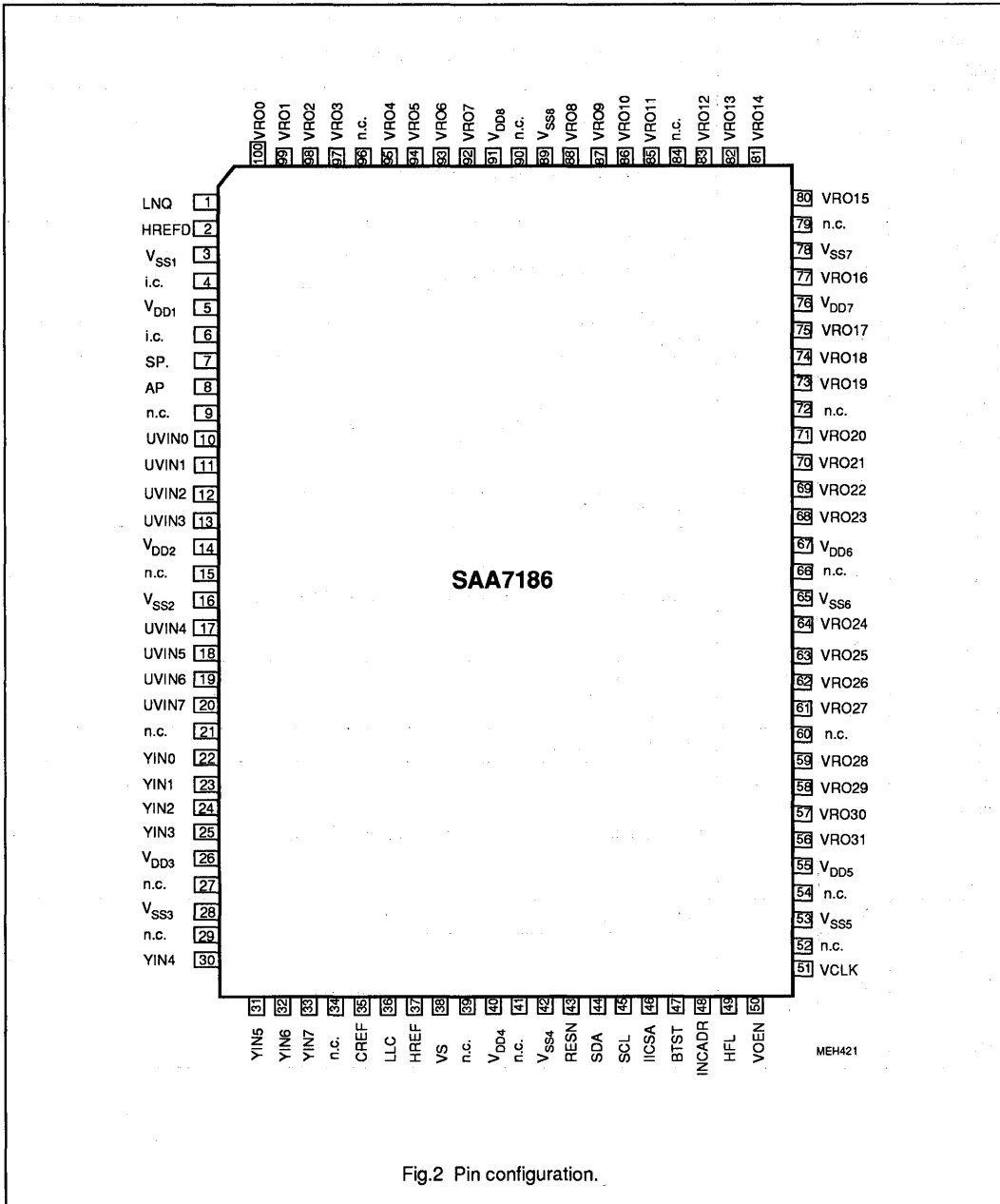

Fig.2 Pin configuration.



# Digital video scaler

# SAA7186

## 7. FUNCTIONAL DESCRIPTION

The input port is output of Philips digital video multistandard decoders (SAA7151B, SAA7191B) or other similar sources.

The SAA7186 input supports the 16-bit YUV 4:2:2 format.

The video data from the input port are converted into a unique internal two's complement data stream and are processed in horizontal direction in two separate decimation filters. Then they are processed in vertical direction by the vertical processing unit (VPU).

Chrominance data are interpolated to a 4:4:4 format; a chroma keying bit is generated.

The 4:4:4 YUV data are then converted from the YUV to the RGB domain in a digital matrix. ROM tables in the RGB data path can be used for anti-gamma correction of gamma-corrected input signals. Uncorrected RGB and YUV signals can be bypassed.

A scale control unit generates reference and gate signals for scaling of the processed video data. After data formatting to the various VRAM port formats, the scaled video data are buffered in the 16 word x 32-bit output FIFO register. The FIFO output is directly connected to the VRAM output bus VRO(31-0). Specific reference signals support an easy memory interfacing.

All functions of the SAA7186 are controlled via I<sup>2</sup>C-bus using 17 subaddresses. The external microcontroller can get information by reading the status register.

### Video input port

The 16-bit YUV input data in 4:2:2 format (Table 1) consist of 8-bit luminance data Y (pins YIN(7-0)) and 8-bit time-multiplexed colour-difference data UV (pins UVIN(7-0)).

The input data are clocked in by the signals LLC and CREF (Fig.3). HREF and VS inputs define the video scan pattern (window).

### Sequential input data

- are limited to maximum 768 active pixels per line if the vertical filter is active
- UV can be processed in straight binary and two's complement representation (controlled by TCC)

### Decimation filters

The decimation filters perform accurate horizontal filtering of the input data stream. Signal characteristics are matched in front of the pixel decimation stage, thus disturbing artifacts, caused by the pixel dropping, are reduced.

The signal bandwidth can be reduced in steps of:  
 2-tap filter = -6 dB at 0.325 pixel rate  
 3-tap filter = -6 dB at 0.25 pixel rate  
 4-tap filter = -6 dB at 0.21 pixel rate  
 5-tap filter = -6 dB at 0.125 pixel rate  
 9-tap filter = -6 dB at 0.075 pixel rate

The different characteristics are chosen dependent on the defined scaling parameters in an adaptive filter mode (AFS-bit = 1). The filter characteristics can also be selected independently by control bits HF2 to HF0 at AFS-bit = 0.

### Vertical filters

Y and UV data are handled in separate filters (Fig.1). Each of the two line memories has a capacity of 2 x 768 x 8-bit. Thus two complete video lines of 4:2:2 YUV data can be stored. The VPU is split into two memory banks and one arithmetic unit. The available processing modes, respectively transfer functions, are selectable by the bits VP1 and VP0 if AFS = 0. An adaptive mode is selected by AFS = 1. Disturbing artifacts, generated by line dropping, are reduced.

### Adaptive filter selection (AFS = 1):

scaling ratio	filter function (refer to I <sup>2</sup> C section)
XD/XS	horizontal
≤1	bypassed
≤14/15	filter 1
≤11/15	filter 6
≤7/15	filter 3
≤3/15	filter 4
YD/YS	vertical
≤1	bypassed
≤13/15	filter 1
≤4/15	filter 2

### RGB matrix

Y data and UV data are converted after interpolation into RGB data according to CCIR601 recommendation. Data are bypassed in YUV or monochrome modes.

**Table 1** 4 : 2 : 2 format (pixels per line). The time frames are controlled by the HREF signal.

INPUT	PIXEL BYTE SEQUENCE				
	Ye7	Yo7	Ye7	Yo7	Ye7
YIN7	Ye7	Yo7	Ye7	Yo7	Ye7
YIN6	Ye6	Yo6	Ye6	Yo6	Ye6
YIN5	Ye5	Yo5	Ye5	Yo5	Ye5
YIN4	Ye4	Yo4	Ye4	Yo4	Ye4
YIN3	Ye3	Yo3	Ye3	Yo3	Ye3
YIN2	Ye2	Yo2	Ye2	Yo2	Ye2
YIN1	Ye1	Yo1	Ye1	Yo1	Ye1
YIN0	Ye0	Yo0	Ye0	Yo0	Ye0
UVIN7	Ue7	Ve7	Ue7	Ve7	Ue7
UVIN6	Ue6	Ve6	Ue6	Ve6	Ue6
UVIN5	Ue5	Ve5	Ue5	Ve5	Ue5
UVIN4	Ue4	Ve4	Ue4	Ve4	Ue4
UVIN3	Ue3	Ve3	Ue3	Ve3	Ue3
UVIN2	Ue2	Ve2	Ue2	Ve2	Ue2
UVIN1	Ue1	Ve1	Ue1	Ve1	Ue1
UVIN0	Ue0	Ve0	Ue0	Ve0	Ue0
Y frame	0	1	2	3	4
UV frame	0		2		4

e = even pixel; o = odd pixel

# Digital video scaler

# SAA7186

The matrix equations are these considering the digital quantization:

$$\begin{aligned}
 R &= Y + 1.375 V \\
 G &= Y - 0.703125 V - 0.34375 U \\
 B &= Y + 1.734375 U.
 \end{aligned}$$

**Anti-gamma ROM tables:**

ROM tables are implemented at the matrix output to provide anti-gamma correction of the RGB data. A curve for a gamma of 1.4 is implemented

The tables can be used (RTB-bit = 0) to compensate gamma correction for linear data representation of RGB output data.

**Chrominance signal keyer**

The keyer generates an alpha signal to achieve a 5-5-5 + $\alpha$  RGB alpha output signal. Therefore, the processed UV data amplitudes are compared with thresholds set via I<sup>2</sup>C-bus (subaddresses "0C to 0F"). A logical "1" signal is generated if the amplitude is inside the specified amplitude range, otherwise a logical "0" is generated.

Keying can be switched off by setting the lower limit higher than the upper limit ("0E or 0E" and "0D or 0F").

**Scale control and vertical regions**

The scale control block SC includes vertical address/sequence counters to define the current position in the input field and to address the internal VPU memories.

To perform scaling, XD of XS pixel selection in horizontal direction and YD of YS line selection in vertical direction are applied. The pixel and line dropping are controlled at the input of the FIFO register.

To control the decimation filter function and the vertical data processing in the adaptive mode

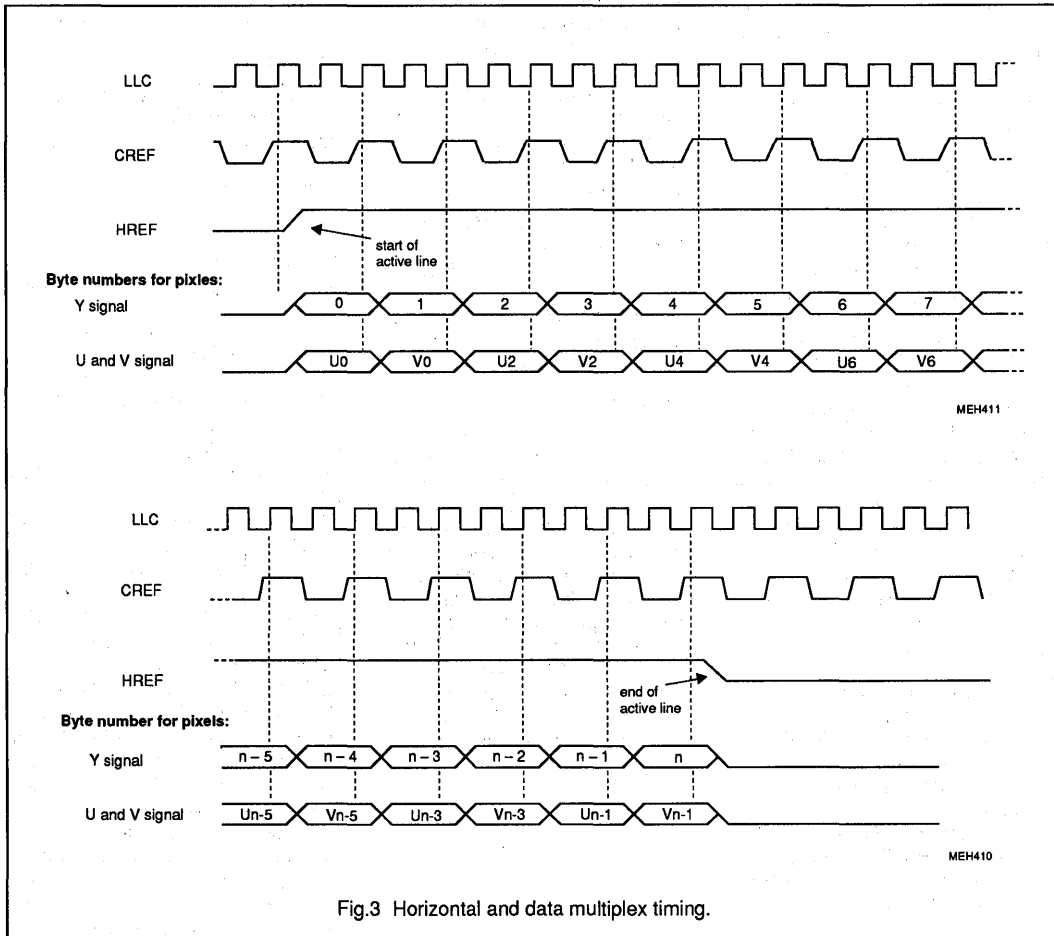

Fig.3 Horizontal and data multiplex timing.

# Digital video scaler

SAA7186

(AFS = 1), the scaling ratio in horizontal and vertical direction is estimated in the SC block.

The input field can be divided into two vertical regions – the bypass region and the scaling region, which are defined via I<sup>2</sup>C-bus by the parameters VS, VC, YO and YS.

### Vertical bypass region:

Data are not scaled and independent of I<sup>2</sup>C-bits FS1, FS0 the output format is always 8-bit grayscale (monochrome). The SAA7186 outputs all active pixels of a line, defined by the HREF input signal if the vertical bypass region is active. This can be used, for example, to store videotext information in the field memory.

The start line of the bypass region is defined by VS; the number of lines to be bypassed is defined by VC.

### Vertical scaling region:

Data is scaled with start at line YO and the output format is selected when FS1, FS0 are valid. This is the "normal operation" area.

The input/output screen dimensions in horizontal and vertical direction are defined by the parameters

XO, XS and XD for horizontal

YO, YS and YD for vertical.

The circuit processes XS samples of a line. Remaining pixels are ignored if a line is longer than XS. If a line is shorter than XS, processing is aborted when the falling edge of HREF is detected.

### Vertical regions in Fig.4:

- the two regions can be programmed via I<sup>2</sup>C-bus, whereby regions should not overlap (active region overrides the bypass region).
- the start of a normal active picture depends on video standard and has to be programmed to the correct value.

- the offsets XO and YO have to be set according to the internal processing delays to ensure the complete number of destination pixels and lines (Table 6).
- the scaling parameters can be used to perform a panning function over the video frame/field.

### Output data representation and levels

Output data representation of the YUV data can be modified by bit MCT (subaddress 10). The DC gain is 1 for YUV input data. The corresponding RGB levels are defined by the matrix equations. The luminance levels are limited according to CCIR 601

16 (239) = black

235 (20) = white

(..) = grayscale luminance levels if the YUV or monochrome luminance output formats are selected.

The signal levels of the RGB formats are limited in 8-bit to "0" or "255". For the 5-bit RGB formats a truncation from 8-bit to 5-bit is implemented.

Fill values are inserted dependent on longword position and destination size:

- "0" in RGB formats and for Y two's complement U, V
- "128" for U, V (straight binary)
- "255" in 8-bit grayscale format

The unused output values of the YUV and grayscale formats can be used for other purposes.

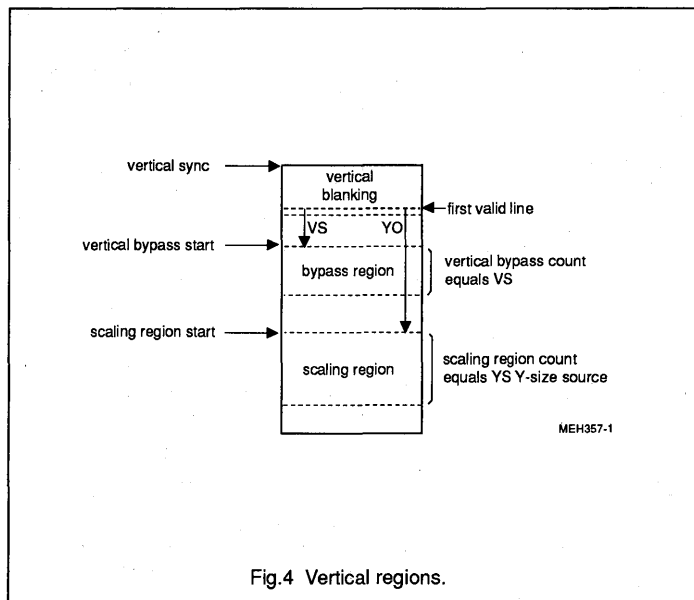

Fig.4 Vertical regions.

Digital video scaler

SAA7186

Table 2 VRAM port output data formats at  $\text{EFE-bit} = 0$  dependent on FS1 and FS0 bits (set via I<sup>2</sup>C-bus)

PIXEL OUTPUT BITS	FS1 = 0; FS0 = 0 RGB 5-5-5 + 1 32-BIT WORDS			FS1 = 0; FS0 = 1 YUV 4:2:2 32-BIT WORDS			FS1 = 1; FS0 = 0 YUV 4:2:2 TEST 16-BIT WORDS			FS1 = 1; FS0 = 1 8-bit monochrome 32-BIT WORDS		
PIXEL ORDER	n	n+2	n+4	n	n+2	n+4	n	n+1	n+2	n	n+4	n+8
VRO31	$\alpha$	$\alpha$	$\alpha$	Ye7	Ye7	Ye7	Ye7	Yo7	Ye7	Ya7	Ya7	Ya7
VRO30	R4	R4	R4	Ye6	Ye6	Ye6	Ye6	Yo6	Ye6	Ya6	Ya6	Ya6
VRO29	R3	R3	R3	Ye5	Ye5	Ye5	Ye5	Yo5	Ye5	Ya5	Ya5	Ya5
VRO28	R2	R2	R2	Ye4	Ye4	Ye4	Ye4	Yo4	Ye4	Ya4	Ya4	Ya4
VRO27	R1	R1	R1	Ye3	Ye3	Ye3	Ye3	Yo3	Ye3	Ya3	Ya3	Ya3
VRO26	R0	R0	R0	Ye2	Ye2	Ye2	Ye2	Yo2	Ye2	Ya2	Ya2	Ya2
VRO25	G4	G4	G4	Ye1	Ye1	Ye1	Ye1	Yo1	Ye1	Ya1	Ya1	Ya1
VRO24	G3	G3	G3	Ye0	Ye0	Ye0	Ye0	Yo0	Ye0	Ya0	Ya0	Ya0
VRO23	G2	G2	G2	Ue7	Ue7	Ue7	Ue7	Ve7	Ue7	Yb7	Yb7	Yb7
VRO22	G1	G1	G1	Ue6	Ue6	Ue6	Ue6	Ve6	Ue6	Yb6	Yb6	Yb6
VRO21	G0	G0	G0	Ue5	Ue5	Ue5	Ue5	Ve5	Ue5	Yb5	Yb5	Yb5
VRO20	B4	B4	B4	Ue4	Ue4	Ue4	Ue4	Ve4	Ue4	Yb4	Yb4	Yb4
VRO19	B3	B3	B3	Ue3	Ue3	Ue3	Ue3	Ve3	Ue3	Yb3	Yb3	Yb3
VRO18	B2	B2	B2	Ue2	Ue2	Ue2	Ue2	Ve2	Ue2	Yb2	Yb2	Yb2
VRO17	B1	B1	B1	Ue1	Ue1	Ue1	Ue1	Ve1	Ue1	Yb1	Yb1	Yb1
VRO16	B0	B0	B0	Ue0	Ue0	Ue0	Ue0	Ve0	Ue0	Yb0	Yb0	Yb0
PIXEL ORDER	n+1	n+3	n+5	n+1	n+3	n+5	OUTPUTS NOT USED			n+2	n+6	n+10
VRO15	$\alpha$	$\alpha$	$\alpha$	Yo7	Yo7	Yo7	X	X	X	Yc7	Yc7	Yc7
VRO14	R4	R4	R4	Yo6	Yo6	Yo6	X	X	X	Yc6	Yc6	Yc6
VRO13	R3	R3	R3	Yo5	Yo5	Yo5	X	X	X	Yc5	Yc5	Yc5
VRO12	R2	R2	R2	Yo4	Yo4	Yo4	X	X	X	Yc4	Yc4	Yc4
VRO11	R1	R1	R1	Yo3	Yo3	Yo3	X	X	X	Yc3	Yc3	Yc3
VRO10	R0	R0	R0	Yo2	Yo2	Yo2	X	X	X	Yc2	Yc2	Yc2
VRO9	G4	G4	G4	Yo1	Yo1	Yo1	X	X	X	Yc1	Yc1	Yc1
VRO8	G3	G3	G3	Yo0	Yo0	Yo0	X	X	X	Yc0	Yc0	Yc0
VRO7	G2	G2	G2	Ve7	Ve7	Ve7	X	X	X	Yd7	Yd7	Yd7
VRO6	G1	G1	G1	Ve6	Ve6	Ve6	X	X	X	Yd6	Yd6	Yd6
VRO5	G0	G0	G0	Ve5	Ve5	Ve5	X	X	X	Yd5	Yd5	Yd5
VRO4	B4	B4	B4	Ve4	Ve4	Ve4	X	X	X	Yd4	Yd4	Yd4
VRO3	B3	B3	B3	Ve3	Ve3	Ve3	X	X	X	Yd3	Yd3	Yd3
VRO2	B2	B2	B2	Ve2	Ve2	Ve2	X	X	X	Yd2	Yd2	Yd2
VRO1	B1	B1	B1	Ve1	Ve1	Ve1	X	X	X	Yd1	Yd1	Yd1
VRO0	B0	B0	B0	Ve0	Ve0	Ve0	X	X	X	Yd0	Yd0	Yd0

$\alpha$  = keying bit; R, G, B, Y, U and V = digital signals; e = even pixel number; o = odd pixel number; a b c d = consecutive pixels

## Digital video scaler

SAA7186

**Table 3** VRAM port output data formats at  $\overline{\text{EFE-bit}} = 1$  depend on FS1 and FS0 bits (set via I<sup>2</sup>C-bus)

PIXEL OUTPUT BITS	FS1 = 0; FS0 = 0 RGB 5-5-5 + 1 16-BIT WORDS			FS1 = 0; FS0 = 1 YUV 4:2:2 16-BIT WORDS			FS1 = 1; FS0 = 0 RGB 8-8-8 24-BIT WORDS			FS1 = 1; FS0 = 1 8-bit monochrome 16-BIT WORDS		
	n	n+1	n+2	n	n+1	n+2	n	n+1	n+2	n	n+2	n+4
VRO31	$\alpha$	$\alpha$	$\alpha$	Ye7	Yo7	Ye7	R7	R7	R7	Ya7	Ya7	Ya7
VRO30	R4	R4	R4	Ye6	Yo6	Ye6	R6	R6	R6	Ya6	Ya6	Ya6
VRO29	R3	R3	R3	Ye5	Yo5	Ye5	R5	R5	R5	Ya5	Ya5	Ya5
VRO28	R2	R2	R2	Ye4	Yo4	Ye4	R4	R4	R4	Ya4	Ya4	Ya4
VRO27	R1	R1	R1	Ye3	Yo3	Ye3	R3	R3	R3	Ya3	Ya3	Ya3
VRO26	R0	R0	R0	Ye2	Yo2	Ye2	R2	R2	R2	Ya2	Ya2	Ya2
VRO25	G4	G4	G4	Ye1	Yo1	Ye1	R1	R1	R1	Ya1	Ya1	Ya1
VRO24	G3	G3	G3	Ye0	Yo0	Ye0	R0	R0	R0	Ya0	Ya0	Ya0
VRO23	G2	G2	G2	Ue7	Ve7	Ue7	G7	G7	G7	Yb7	Yb7	Yb7
VRO22	G1	G1	G1	Ue6	Ve6	Ue6	G6	G6	G6	Yb6	Yb6	Yb6
VRO21	G0	G0	G0	Ue5	Ve5	Ue5	G5	G5	G5	Yb5	Yb5	Yb5
VRO20	B4	B4	B4	Ue4	Ve4	Ue4	G4	G4	G4	Yb4	Yb4	Yb4
VRO19	B3	B3	B3	Ue3	Ve3	Ue3	G3	G3	G3	Yb3	Yb3	Yb3
VRO18	B2	B2	B2	Ue2	Ve2	Ue2	G2	G2	G2	Yb2	Yb2	Yb2
VRO17	B1	B1	B1	Ue1	Ve1	Ue1	G1	G1	G1	Yb1	Yb1	Yb1
VRO16	B0	B0	B0	Ue0	Ve0	Ue0	G0	G0	G0	Yb0	Yb0	Yb0
PIXEL ORDER	n	n+1	n+2	n	n+1	n+2	n	n+1	n+2	n	n+2	n+4
VRO15	X	X	X	X	X	X	B7	B7	B7	X	X	X
VRO14	X	X	X	X	X	X	B6	B6	B6	X	X	X
VRO13	X	X	X	X	X	X	B5	B5	B5	X	X	X
VRO12	X	X	X	X	X	X	B4	B4	B4	X	X	X
VRO11	X	X	X	X	X	X	B3	B3	B3	X	X	X
VRO10	X	X	X	X	X	X	B2	B2	B2	X	X	X
VRO9	X	X	X	X	X	X	B1	B1	B1	X	X	X
VRO8	X	X	X	X	X	X	B0	B0	B0	X	X	X
VRO7(1)(2)	$\alpha$	$\alpha$	$\alpha$	$\alpha$	X	$\alpha$	$\alpha$	$\alpha$	$\alpha$	$\alpha$	$\alpha$	$\alpha$
VRO6 (2)	O/E	O/E	O/E	O/E	O/E	O/E	O/E	O/E	O/E	O/E	O/E	O/E
VRO5 (2)	VGt	VGt	VGt	VGt	VGt	VGt	VGt	VGt	VGt	VGt	VGt	VGt
VRO4 (2)	HGT	HGT	HGT	HGT	HGT	HGT	HGT	HGT	HGT	HGT	HGT	HGT
VRO3	X	X	X	X	X	X	X	X	X	X	X	X
VRO2 (2)	HRF	HRF	HRF	HRF	HRF	HRF	HRF	HRF	HRF	HRF	HRF	HRF
VRO1 (2)	LNQ	LNQ	LNQ	LNQ	LNQ	LNQ	LNQ	LNQ	LNQ	LNQ	LNQ	LNQ
VRO0 (2)	PXQ	PXQ	PXQ	PXQ	PXQ	PXQ	PXQ	PXQ	PXQ	PXQ	PXQ	PXQ

$\alpha$  = keying bit; R, G, B, Y, U and V = digital signals; e = even pixel number; o = odd pixel number; a b c d = consecutive pixels; O/E = odd/even flag

(1) YUV 16-bit format: the keying signal  $\alpha$  is defined only for YU time steps. The corresponding YV sample has also to be keyed. The  $\alpha$  signal in monochrome mode can be used only in the transparent mode (TTR = 1), in this case Ya = Yb.

(2) Data valid only when transparent mode active (TTR-bit = 1) and VCLK pin connected to LLC/2 clock rate.

## Digital video scaler

SAA7186

**Output FIFO register and VRAM output port**

The output FIFO register is the buffer between the video data stream and the VRAM data input port. Resized video data are buffered and formatted. 32-, 24- and 16-bit video data modes are supported. The various formats are selected by the bits EFE, FS1 and FS0. VRAM port formats are shown in Tables 2 and 3. The FIFO register capacity is 16 word x 32 bit (for 32-, 24-, or 16-bit video data). The bits LW1 and LW0 can be used to define the position of the first pixel each line in the 32-bit longword formats or to shift the UV sequence to VU in the 16-bit YUV formats (LW1 = 1).

VRAM port inputs are:

VCLK to clock the FIFO register output data and VOEN to enable output data.

VRAM port outputs are:

the HFL flag (half-full flag), the signal INCADR (refer to section "data burst transfer") and the reference signals for pixel and line selection on outputs VRO(7-0) (only for 24- and 16-bit video data formats refer to "transparent data transfer").

**VRAM port transfer procedures**

Data transfer on the VRAM port can be done asynchronously controlled by outputs HFL, INCADR and input VCLK (data burst transfer with bit TTR = 0).

Data transfer on the VRAM port can be done synchronously controlled by output reference signals on outputs VRO(7-0) and a clock rate of LLC/2 on input VCLK (transparent data transfer with bit TTR = 1 and EFE = 1).

The scaling capability of the SAA7186 can be used in various applications.

**Data burst transfer mode**

Data transfer on the VRAM port is asynchronously (TTR = 0). This mode can be used for all output formats. Four signals for communication with the external memory are provided.

- HFL flag, the half-full flag of the FIFO output register is raised when the FIFO contains at least 8 data words (HFL = HIGH).

By setting HFL = 1, the SAA7186 requests a data burst transfer by the external memory controller, that has to start a transfer cycle within the next 32 LLC cycles for 32-bit longword modes (16 LLC cycles for 16- and 24-bit modes). If there are pixels in the FIFO at the end of a line, which are not transferred, the circuit fills up the FIFO register with "fill pixels" until it is half-full and sets the HFL flag to request a data burst transfer. After transfer is done, HFL is used in combination with INCADR to indicate the line increments (Figures 6 and 7).

- INCADR output signal is used in combination with HFL to control horizontal and vertical address generation for a memory controller. The pulse sequence depends on field formats (interlace/ non-interlace or odd/even fields, Figures 6 and 7) and control bits OF (subaddress 00).

HFL = 1 at the rising edge of INCADR:

the end of line is reached, request for line address increment  
HFL = 0 at the rising edge of INCADR:

the end of field/frame is reached, request for line and pixel addresses reset

(The distance from the last half-full request HFL to the INCADR pulse may be longer than 64 x LLC. The HFL state is defined for minimum 4 x LLC in front of the rising edge of INCADR and minimum 2 x LLC afterwards.)

- VCLK input signal to clock the FIFO register output data VRO(n). New data are placed on the VRO(n) port with the rising edge of VCLK (Fig.5).

- VOEN input enables output data VRO(n). The outputs are in 3-state mode at VOEN = HIGH. VOEN changes only when VCLK

is LOW. If VCLK pulses are applied during VOEN = HIGH, the outputs remain inactive, but the FIFO register accepts the pulses.

**Transparent data transfer mode**

Data transfer on the VRAM port can be achieved synchronously (TTR = 1). With a continuous clock rate of LLC/2 on input VCLK, the SAA7186 delivers a continuously processed data stream. Therefore, the extended formats of the VRAM output port have to be selected (bit EFE = 1; Table 3). The reference and gate signals on outputs VRO(6-1) and the LNQ signal are delivered in each field (means scaled and ignored fields). The PXO signal (also VRO0) is only delivered in active fields. The output signals VRO(7-0) can be used to buffer qualified pre-processed RGB or YUV video data (notice: the YUV data are only valid in qualified time slots). Control output signals in Table 3 are:

$\alpha$	keying signal of the chroma keyer
O/E	odd/even field bit according to the internal field processing
VGT	vertical gate signal, "1" marks the scaling window in vertical direction from YO to (YO + YS) lines, cut by VS.
HGT	horizontal gate signal, "1" marks horizontal direction from XO to (XO + XS) lines, cut by HREF.
HRF	delay compensated horizontal reference signal.
LNQ	line qualifier signal, active polarity is defined by QPL bit.
PXQ	pixel qualifier signal, active polarity is defined by QPP bit.

**Power-on reset**

- the FIFO register contents are undefined
- outputs VRO are set to high-impedance state
- output INCADR = HIGH
- output HFL = LOW until the VPE bit is set to "1"
- subaddress "10" is set to 00h and VPE-bit in subaddress "00" is set to zero (Table 4).

Digital video scaler

SAA7186

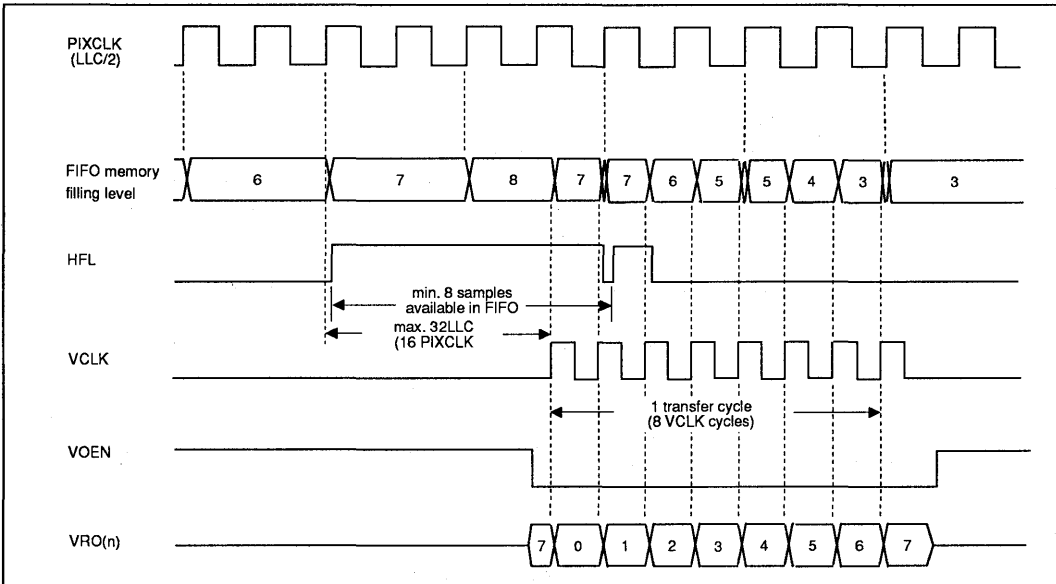

MEH407

Fig.5 Output port transfer to VRAM at 32-bit data format without scaling. If VCLK cycles occur at VOEN = HIGH, the FIFO register is unchanged, but the outputs VRO(31-0) remain in 3-state position.

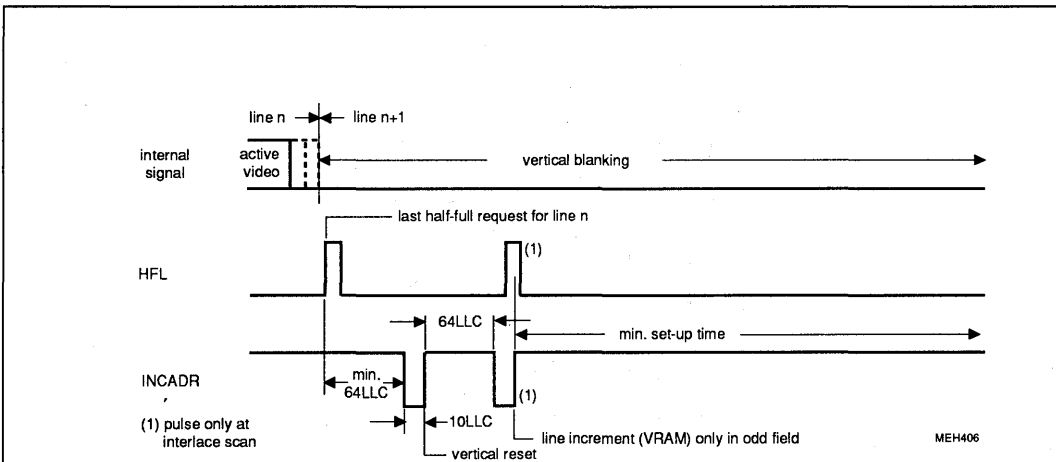

MEH406

Fig.6 Vertical reset timing to the VRAM.





## Digital video scaler

## SAA7186

### Field processing

The phase of the field sequence (odd/even dependent on inputs HREF and VS) is detected by means of the falling edge of VS. The current field phase is reported in the status byte by the OEF bit (Table 5). OEF bit can be stable 0 or 1 for non-interlaced input frames or non standard input signals VS and/or HREF (nominal condition for VS and HREF – SAA7191 B with active vertical noise limiter). A free-running odd/even flag is generated for internal field processing if the detection reports a stable OEF bit.

The POE bit (subaddress 0B) can be used to change the polarity of the internal flag (in case of non-standard VS and HREF signals) to control the phase of the free-running flag, and to compensate mis-detections. Thus, the SAA7186 can be used under various VS/HREF timing conditions.

The SAA7186 operates on fields. To support progressive displays and to avoid movement blurring and artifacts, the circuit can process both or single fields of interlaced or non-interlaced input data. Therefore the OF bits can be used. The bits OF1 and OF0 (Table 6) determine the INCADR/HFL generation in "data

burst transfer mode". One of the fields (odd or even) is ignored when OF1 = 1; then no line increment sequence (INCADR/HFL) is generated, the vertical reset pulse is only generated.

With OF1 = OF0 = 0 the circuit supports correct interlaced data storage. Two INCADR/HFL sequences are generated in each qualified line; additionally an INCADR/HFL sequence after the vertical reset sequence of an odd field is generated. Thereby, the scaled lines are automatically stored in the right sequence.

### 8. OPERATION CYCLE

The operation is synchronized by the input field. The cycle is specified in the flow chart (Fig.9).

The circuit is inactive after power-on reset, VPO is 0 and the FIFO control is set "empty". The internal control registers are updated with the falling edge of VS signal. The circuit is switched active and waits for a transmission of VS and a vertical reset sequence to the memory controller. Afterwards, the circuit waits for the beginning of a scaling or bypass region. The processing of a current line is finished when a vertical sync pulse appears. The

circuit performs a coefficient update and generates a new vertical reset (if it is still active).

Line processing starts when a line is decided to be active, the circuit starts to scale it. Active pixels are loaded into the FIFO register. An HFL flag is generated to initialize a data transfer when eight words are completed. The line end is reached when the programmed pixel number is processed or when a horizontal sync pulse occurs. If there are pixels in the FIFO register, it is filled up until it is half-full to cause a data transfer. Horizontal increment pulses are transmitted after this data transfer.

#### Remarks:

The SAA7186 will always wait for the HREF/VS pulse before the line increment/vertical reset sequence is performed.

After each line/field, the FIFO control is set to empty when INCADR/HFL sequence is transmitted.

No additional actions are necessary if the memory controller has ignored the HFL signal. There is no need to handle overflow/underflow of the FIFO register.

# Digital video scaler

SAA7186

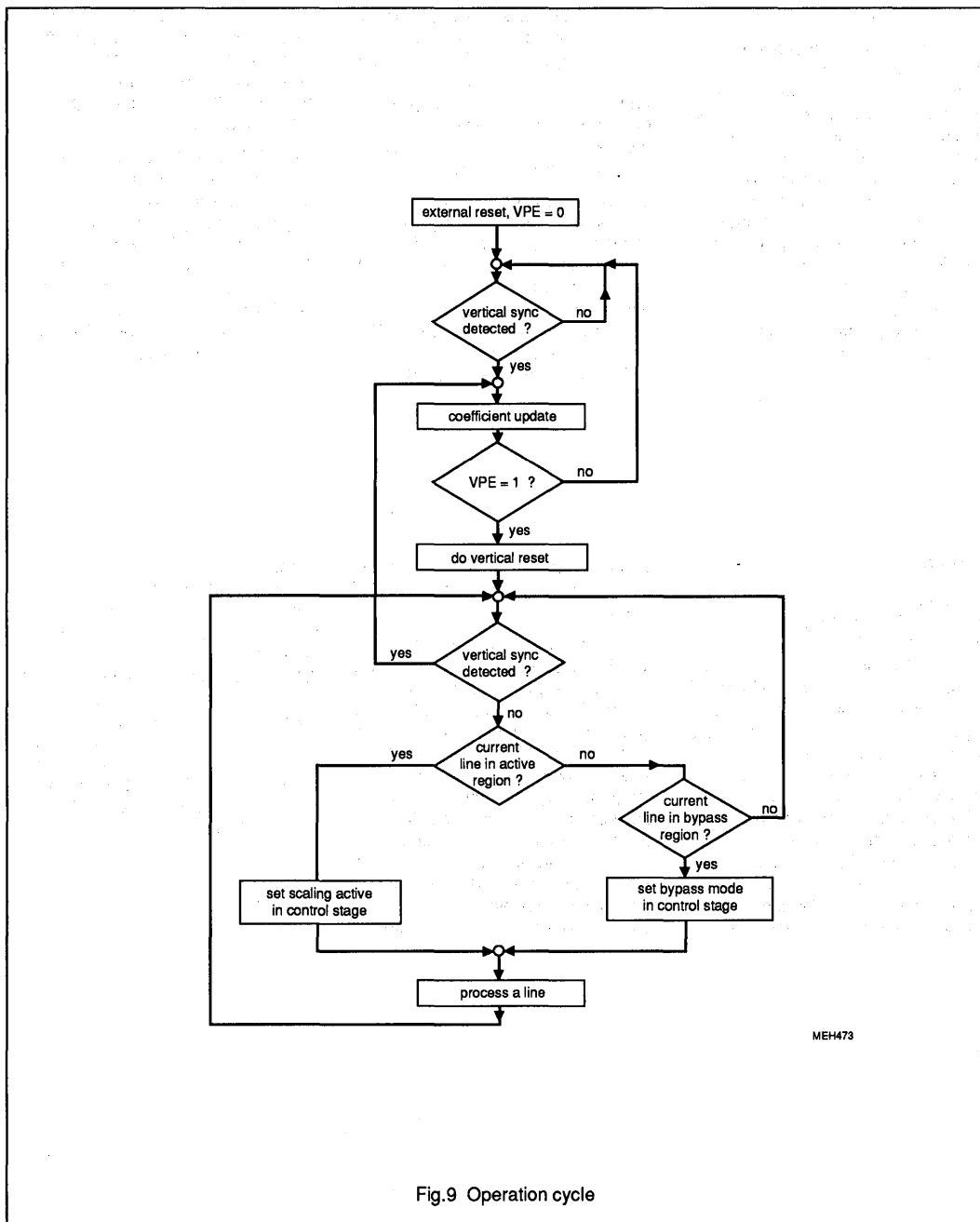

MEH473

Fig.9 Operation cycle

Digital video scaler

SAA7186

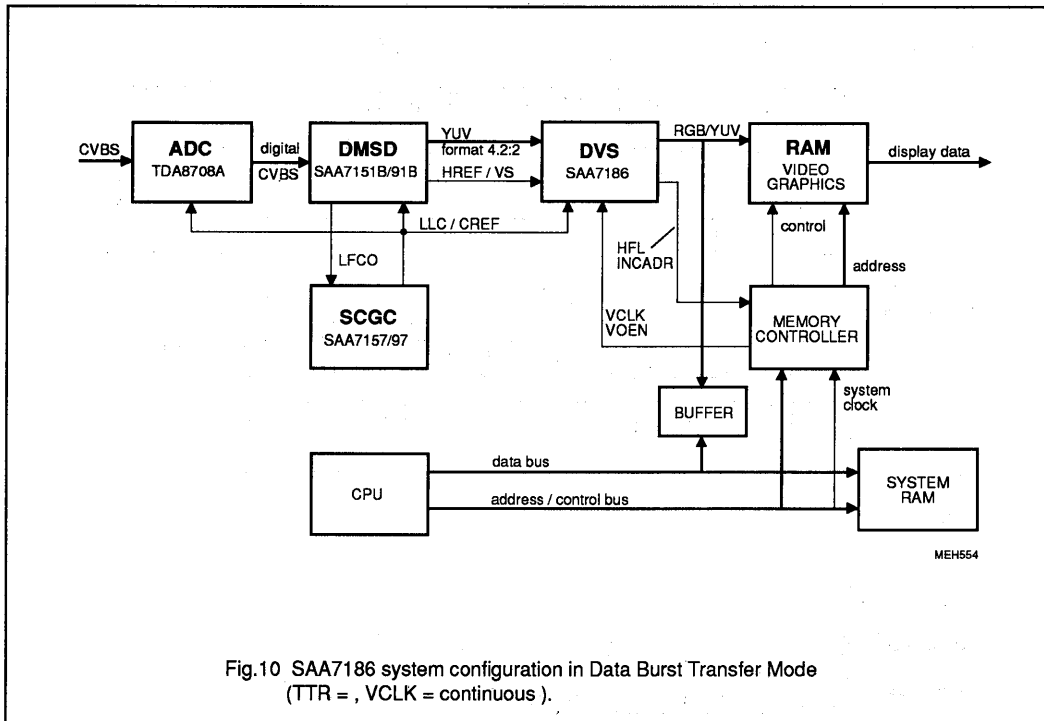

Fig.10 SAA7186 system configuration in Data Burst Transfer Mode (TTR = , VCLK = continuous ).

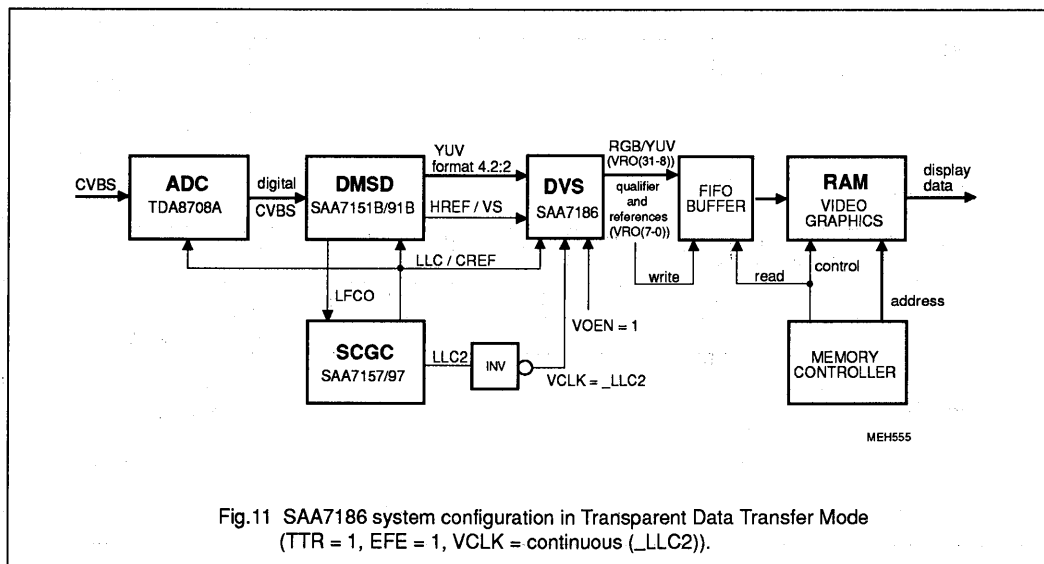

Fig.11 SAA7186 system configuration in Transparent Data Transfer Mode (TTR = 1, EFE = 1, VCLK = continuous (\_LLC2)).

Digital video scaler

SAA7186

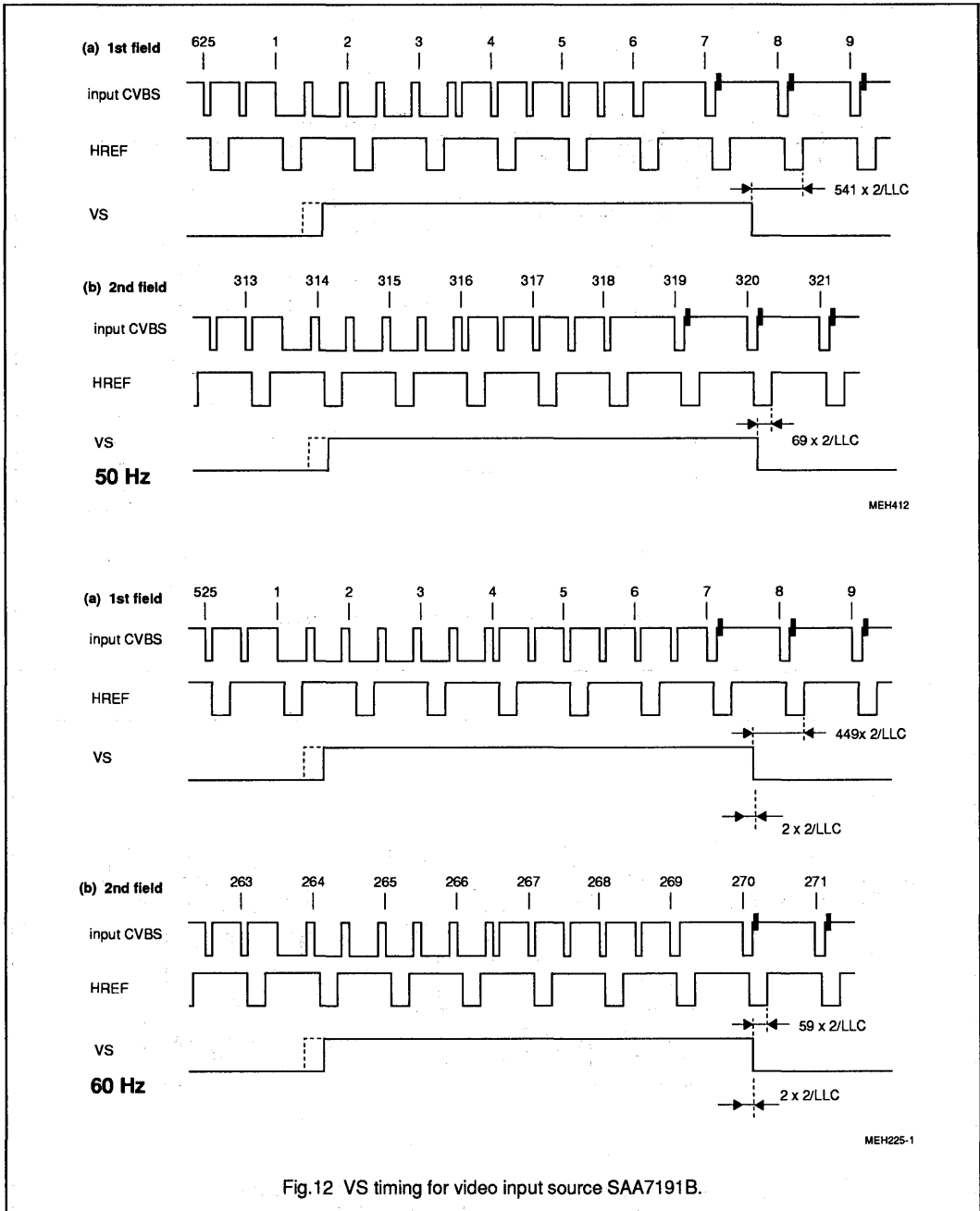

Fig.12 VS timing for video input source SAA7191B.

# Digital video scaler

SAA7186

## 9. I<sup>2</sup>C-BUS FORMAT

S	SLAVE ADDRESS	A	SUBADDRESS	A	DATA0	A	-----	DATA <sub>n</sub>	A	P
---	---------------	---	------------	---	-------	---	-------	-------------------	---	---

- S = start condition
- SLAVE ADDRESS = **1011 100X** (IICSA = LOW) or **1011 110X** (IICSA = HIGH)
- A = acknowledge, generated by the slave
- SUBADDRESS\* = subaddress byte (Table 4)
- DATA = data byte (Table 4)
- P = stop condition
  
- X = read/write control bit  
 X = 0, order to write (the circuit is slave receiver)  
 X = 1, order to read (the circuit is slave transmitter)

\* If more than 1 byte DATA are transmitted, then auto-increment of the subaddress is performed.

**Table 4** I<sup>2</sup>C-bus; subaddress and data bytes for writing (X in address byte = 0 ).

FUNCTION	SUBADDRESS	DATA								DF*
		D7	D6	D5	D4	D3	D2	D1	D0	
Formats and sequence	00	RTB	OF1	OF0	VPE	LW1	LW0	FS1	FS0	tbf
Output data pixel/line continued in	01	XD7	XD6	XD5	XD4	XD3	XD2	XD1	XD0	
Input data pixel/line continued in	02	XS7	XS6	XS5	XS4	XS3	XS2	XS1	XS0	
Horizontal window start	03	XO7	XO6	XO5	XO4	XO3	XO2	XO1	XO0	
Pixel decimation filter	04	HF2	HF1	HF0	XO8	XS9	XS8	XD9	XD8	
Output data lines/field continued in	05	YD7	YD6	YD5	YD4	YD3	YD2	YD1	YD0	
Input data lines/field continued in	06	YS7	YS6	YS5	YS4	YS3	YS2	YS1	YS0	
Vertical window start	07	YO7	YO6	YO5	YO4	YO3	YO2	YO1	YO0	
AFS/vertical processing	08	AFS	VP1	VP0	YO8	YS9	YS8	YD9	YD8	
Vertical bypass start continued in	09	VS7	VS6	VS5	VS4	VS3	VS2	VS1	VS0	
Vertical bypass count continued in	0A	VC7	VC6	VC5	VC4	VC3	VC2	VC1	VC0	
	0B	TCC	0	0	VS8	0	VC8	0	POE	
Chroma keying										
lower limit for V	0C	VL7	VL6	VL5	VL4	VL3	VL2	VL1	VL0	
upper limit for V	0D	VU7	VU6	VU5	VU4	VU3	VU2	VU1	VU0	
lower limit for U	0E	UL7	UL6	UL5	UL4	UL3	UL2	UL1	UL0	
upper limit for U	0F	UU7	UU6	UU5	UU4	UU3	UU2	UU1	UU0	
Byte 10**	10	0	0	0	MCT	QPL	QPP	TTR	EFE	
Unused	11 to 1F									

\*) Default register contents fill in by hand  
 \*\*) Byte 10 is set to 00h after power-on reset.

Digital video scaler

SAA7186

**Table 5** I<sup>2</sup>C-bus status byte (X in address byte = 1)

FUNCTION	DATA								
	D7	D6	D5	D4	D3	D2	D1	D0	
status byte	ID3	ID2	ID1	ID0	0	0	OEF	SVP	

Function of status bits:

ID3 to ID0

Software version of SAA7186 compatible with

ID3	ID2	ID1	ID0	version
0	0	0	1	1

OEF

Identification of field sequence dependent on inputs HREF and VS:

0 = even field detected; 1 = odd field detected

SVP

State of VRAM port:

0 = inputs HFL and INCADR inactive;

1 = inputs HFL and INCADR active.

**Table 6** Function of the register bits of Table 4

"00" RTB	ROM table bypass switch: 0 = anti-gamma ROM active 1 = table is bypassed																																																																																														
OF1 to OF0	Set output field mode: <table border="1"> <thead> <tr> <th>OF1</th> <th>OF0</th> <th colspan="4">field mode DVS process</th> </tr> </thead> <tbody> <tr> <td>0</td> <td>0</td> <td colspan="4">both fields for interlaced storage</td> </tr> <tr> <td>0</td> <td>1</td> <td colspan="4">both fields for non-interlaced storage</td> </tr> <tr> <td>1</td> <td>0</td> <td colspan="4">odd fields only (even fields ignored) for non-interlaced storage</td> </tr> <tr> <td>1</td> <td>1</td> <td colspan="4">even fields only(odd fields ignored) for non-interlaced storage</td> </tr> </tbody> </table>						OF1	OF0	field mode DVS process				0	0	both fields for interlaced storage				0	1	both fields for non-interlaced storage				1	0	odd fields only (even fields ignored) for non-interlaced storage				1	1	even fields only(odd fields ignored) for non-interlaced storage																																																														
OF1	OF0	field mode DVS process																																																																																													
0	0	both fields for interlaced storage																																																																																													
0	1	both fields for non-interlaced storage																																																																																													
1	0	odd fields only (even fields ignored) for non-interlaced storage																																																																																													
1	1	even fields only(odd fields ignored) for non-interlaced storage																																																																																													
VPE	VRAM port outputs enable: 0 = HFL and INCADR inactive; VRO outputs in 3-state position (HFL = LOW, INCADR = HIGH) 1 = HFL and INCADR enabled; VRO outputs dependent on VOEN																																																																																														
LW1 to LW0	First pixel position in VRO data for FS1 = 0; FS0 = 0 (RGB) and FS1 = 0; FS0 = 1(YUV): <table border="1"> <thead> <tr> <th>LW1</th> <th>LW0</th> <th>31 to 24</th> <th>23 to 16</th> <th>15 to 8</th> <th>7 to 0</th> <th></th> </tr> </thead> <tbody> <tr> <td>0</td> <td>0</td> <td>pixel 0</td> <td>pixel 0</td> <td>pixel 1</td> <td>pixel 1</td> <td rowspan="4">) EFE = 0, TRR = 0</td> </tr> <tr> <td>0</td> <td>1</td> <td>pixel 0</td> <td>pixel 0</td> <td>pixel 1</td> <td>pixel 1</td> </tr> <tr> <td>1</td> <td>0</td> <td>black</td> <td>black</td> <td>pixel 0</td> <td>pixel 0</td> </tr> <tr> <td>1</td> <td>1</td> <td>black</td> <td>black</td> <td>pixel 0</td> <td>pixel 0</td> </tr> </tbody> </table> First pixel position in VRO data for FS1 = 1; FS0 = 1 (monochrome): <table border="1"> <thead> <tr> <th>LW1</th> <th>LW0</th> <th>31 to 24</th> <th>23 to 16</th> <th>15 to 8</th> <th>7 to 0</th> <th></th> </tr> </thead> <tbody> <tr> <td>0</td> <td>0</td> <td>pixel 0</td> <td>pixel 1</td> <td>pixel 2</td> <td>pixel 3</td> <td rowspan="4">) EFE = 0, TRR = 0</td> </tr> <tr> <td>0</td> <td>1</td> <td>black</td> <td>pixel 0</td> <td>pixel 1</td> <td>pixel 2</td> </tr> <tr> <td>1</td> <td>0</td> <td>black</td> <td>black</td> <td>pixel 0</td> <td>pixel 1</td> </tr> <tr> <td>1</td> <td>1</td> <td>black</td> <td>black</td> <td>black</td> <td>pixel 0</td> </tr> </tbody> </table> <table border="1"> <tbody> <tr> <td>0</td> <td>0</td> <td>pixel 0</td> <td>pixel 1</td> <td>X</td> <td>X</td> <td rowspan="4">) EFE = 1, TRR = 0; LW only effects the greyscale format</td> </tr> <tr> <td>0</td> <td>1</td> <td>black</td> <td>pixel 0</td> <td>X</td> <td>X</td> </tr> <tr> <td>1</td> <td>0</td> <td>pixel 0</td> <td>pixel 1</td> <td>X</td> <td>X</td> </tr> <tr> <td>1</td> <td>1</td> <td>black</td> <td>pixel 0</td> <td>X</td> <td>X</td> </tr> </tbody> </table>						LW1	LW0	31 to 24	23 to 16	15 to 8	7 to 0		0	0	pixel 0	pixel 0	pixel 1	pixel 1	) EFE = 0, TRR = 0	0	1	pixel 0	pixel 0	pixel 1	pixel 1	1	0	black	black	pixel 0	pixel 0	1	1	black	black	pixel 0	pixel 0	LW1	LW0	31 to 24	23 to 16	15 to 8	7 to 0		0	0	pixel 0	pixel 1	pixel 2	pixel 3	) EFE = 0, TRR = 0	0	1	black	pixel 0	pixel 1	pixel 2	1	0	black	black	pixel 0	pixel 1	1	1	black	black	black	pixel 0	0	0	pixel 0	pixel 1	X	X	) EFE = 1, TRR = 0; LW only effects the greyscale format	0	1	black	pixel 0	X	X	1	0	pixel 0	pixel 1	X	X	1	1	black	pixel 0	X	X
LW1	LW0	31 to 24	23 to 16	15 to 8	7 to 0																																																																																										
0	0	pixel 0	pixel 0	pixel 1	pixel 1	) EFE = 0, TRR = 0																																																																																									
0	1	pixel 0	pixel 0	pixel 1	pixel 1																																																																																										
1	0	black	black	pixel 0	pixel 0																																																																																										
1	1	black	black	pixel 0	pixel 0																																																																																										
LW1	LW0	31 to 24	23 to 16	15 to 8	7 to 0																																																																																										
0	0	pixel 0	pixel 1	pixel 2	pixel 3	) EFE = 0, TRR = 0																																																																																									
0	1	black	pixel 0	pixel 1	pixel 2																																																																																										
1	0	black	black	pixel 0	pixel 1																																																																																										
1	1	black	black	black	pixel 0																																																																																										
0	0	pixel 0	pixel 1	X	X	) EFE = 1, TRR = 0; LW only effects the greyscale format																																																																																									
0	1	black	pixel 0	X	X																																																																																										
1	0	pixel 0	pixel 1	X	X																																																																																										
1	1	black	pixel 0	X	X																																																																																										

Digital video scaler

SAA7186

FS1 to FS0	FIFO output register format select (EFE- bit see "10"):																																													
	<table border="1"> <thead> <tr> <th>EFE</th> <th>FS1</th> <th>FS0</th> <th>output format (Tables 2 and 3)</th> </tr> </thead> <tbody> <tr> <td>0</td> <td>0</td> <td>0</td> <td>RGB 5-5-5 + alpa; 2x16-bit/pixel; 32-bit word length; RGB matrix on, VRAM output format</td> </tr> <tr> <td>0</td> <td>0</td> <td>1</td> <td>YUV 4:2:2; 2x16-bit/pixel; 32-bit word length; RGB matrix off, VRAM output format</td> </tr> <tr> <td>0</td> <td>1</td> <td>0</td> <td>YUV 4:2:2; video test mode; 1x16-bit/pixel;16-bit word length; RGB matrix off, optional output format</td> </tr> <tr> <td>0</td> <td>1</td> <td>1</td> <td>monochrome mode; 4x8-bit/pixel; 32-bit word length; RGB matrix off, VRAM output format</td> </tr> <tr> <td>1</td> <td>0</td> <td>0</td> <td>RGB 5-5-5 + alpa; 1x16-bit/pixel; 16-bit word length; RGB matrix on, VRAM output + transparent format</td> </tr> <tr> <td>1</td> <td>0</td> <td>1</td> <td>YUV 4:2:2 + alpa; 1x16-bit/pixel; 16-bit word length; RGB matrix off, VRAM output + transparent format</td> </tr> <tr> <td>1</td> <td>1</td> <td>0</td> <td>RGB 8-8-8 + alpa; 1x24-bit/pixel; 24-bit word length; RGB matrix on, VRAM output + transparent format</td> </tr> <tr> <td>1</td> <td>1</td> <td>1</td> <td>monochrome mode; 2x8-bit/pixel; 16-bit word length; RGB matrix off, VRAM output + transparent format</td> </tr> </tbody> </table>	EFE	FS1	FS0	output format (Tables 2 and 3)	0	0	0	RGB 5-5-5 + alpa; 2x16-bit/pixel; 32-bit word length; RGB matrix on, VRAM output format	0	0	1	YUV 4:2:2; 2x16-bit/pixel; 32-bit word length; RGB matrix off, VRAM output format	0	1	0	YUV 4:2:2; video test mode; 1x16-bit/pixel;16-bit word length; RGB matrix off, optional output format	0	1	1	monochrome mode; 4x8-bit/pixel; 32-bit word length; RGB matrix off, VRAM output format	1	0	0	RGB 5-5-5 + alpa; 1x16-bit/pixel; 16-bit word length; RGB matrix on, VRAM output + transparent format	1	0	1	YUV 4:2:2 + alpa; 1x16-bit/pixel; 16-bit word length; RGB matrix off, VRAM output + transparent format	1	1	0	RGB 8-8-8 + alpa; 1x24-bit/pixel; 24-bit word length; RGB matrix on, VRAM output + transparent format	1	1	1	monochrome mode; 2x8-bit/pixel; 16-bit word length; RGB matrix off, VRAM output + transparent format									
EFE	FS1	FS0	output format (Tables 2 and 3)																																											
0	0	0	RGB 5-5-5 + alpa; 2x16-bit/pixel; 32-bit word length; RGB matrix on, VRAM output format																																											
0	0	1	YUV 4:2:2; 2x16-bit/pixel; 32-bit word length; RGB matrix off, VRAM output format																																											
0	1	0	YUV 4:2:2; video test mode; 1x16-bit/pixel;16-bit word length; RGB matrix off, optional output format																																											
0	1	1	monochrome mode; 4x8-bit/pixel; 32-bit word length; RGB matrix off, VRAM output format																																											
1	0	0	RGB 5-5-5 + alpa; 1x16-bit/pixel; 16-bit word length; RGB matrix on, VRAM output + transparent format																																											
1	0	1	YUV 4:2:2 + alpa; 1x16-bit/pixel; 16-bit word length; RGB matrix off, VRAM output + transparent format																																											
1	1	0	RGB 8-8-8 + alpa; 1x24-bit/pixel; 24-bit word length; RGB matrix on, VRAM output + transparent format																																											
1	1	1	monochrome mode; 2x8-bit/pixel; 16-bit word length; RGB matrix off, VRAM output + transparent format																																											
"01 and 04" XD9 to XD0	Pixel number per line (straight binary) on output (VRO): 00 0000 0000 to 11 1111 1111 (number of XS pixels as a maximum)																																													
"02 and 04" XS9 to XS0	Pixel number per line (straight binary) on inputs (YIN and UVIN): 00 0000 0000 to 11 1111 1111 (number of input pixels per line as maximum)																																													
"03 and 04" XO8 to XO0	Horizontal start position (straight binary) of scaling window (take care of active pixel number per line). start with 1st pixel after HREF rise = 0 0001 0000 to 1 1111 1111 (010 to 1FF)  window start and window end may be cut by internal delay compensated HREF = 0 phase. XO has to be matched to the internal processing delay to get full scaling range																																													
"04" HF2 to HF0	Horizontal decimation filter (Figures 13 and 14): <table border="1"> <thead> <tr> <th>HF2</th> <th>HF1</th> <th>HF0</th> <th>taps</th> <th>filter</th> </tr> </thead> <tbody> <tr> <td>0</td> <td>0</td> <td>0</td> <td>2</td> <td>filter 1 <math>(1/2 (1 + z^{-1}))</math></td> </tr> <tr> <td>0</td> <td>0</td> <td>1</td> <td>3</td> <td>filter 2 <math>(1/4 (1 + 2z^{-1} + z^{-2}))</math></td> </tr> <tr> <td>0</td> <td>1</td> <td>0</td> <td>5</td> <td>filter 3 <math>(1/8 (1 + 2z^{-1} + 2z^{-2} + 2z^{-3} + z^{-4}))</math></td> </tr> <tr> <td>0</td> <td>1</td> <td>1</td> <td>9</td> <td>filter 4 <math>(1/16 (1 + 2z^{-1} + 2z^{-2} + 2z^{-3} + 2z^{-4} + 2z^{-5} + 2z^{-6} + 2z^{-7} + z^{-8}))</math></td> </tr> <tr> <td>1</td> <td>0</td> <td>0</td> <td>1</td> <td>filter bypassed</td> </tr> <tr> <td>1</td> <td>0</td> <td>1</td> <td>1</td> <td>filter bypassed + delay in Y channel of 1T</td> </tr> <tr> <td>1</td> <td>1</td> <td>0</td> <td>8</td> <td>filter 5 <math>(1/16 (1 + 3z^{-1} + 3z^{-2} + z^{-3} + z^{-4} + 3z^{-5} + 3z^{-6} + z^{-7}))</math></td> </tr> <tr> <td>1</td> <td>1</td> <td>1</td> <td>4</td> <td><math>(1/8 (1 + 3z^{-1} + 3z^{-2} + z^{-3}))</math></td> </tr> </tbody> </table>	HF2	HF1	HF0	taps	filter	0	0	0	2	filter 1 $(1/2 (1 + z^{-1}))$	0	0	1	3	filter 2 $(1/4 (1 + 2z^{-1} + z^{-2}))$	0	1	0	5	filter 3 $(1/8 (1 + 2z^{-1} + 2z^{-2} + 2z^{-3} + z^{-4}))$	0	1	1	9	filter 4 $(1/16 (1 + 2z^{-1} + 2z^{-2} + 2z^{-3} + 2z^{-4} + 2z^{-5} + 2z^{-6} + 2z^{-7} + z^{-8}))$	1	0	0	1	filter bypassed	1	0	1	1	filter bypassed + delay in Y channel of 1T	1	1	0	8	filter 5 $(1/16 (1 + 3z^{-1} + 3z^{-2} + z^{-3} + z^{-4} + 3z^{-5} + 3z^{-6} + z^{-7}))$	1	1	1	4	$(1/8 (1 + 3z^{-1} + 3z^{-2} + z^{-3}))$
HF2	HF1	HF0	taps	filter																																										
0	0	0	2	filter 1 $(1/2 (1 + z^{-1}))$																																										
0	0	1	3	filter 2 $(1/4 (1 + 2z^{-1} + z^{-2}))$																																										
0	1	0	5	filter 3 $(1/8 (1 + 2z^{-1} + 2z^{-2} + 2z^{-3} + z^{-4}))$																																										
0	1	1	9	filter 4 $(1/16 (1 + 2z^{-1} + 2z^{-2} + 2z^{-3} + 2z^{-4} + 2z^{-5} + 2z^{-6} + 2z^{-7} + z^{-8}))$																																										
1	0	0	1	filter bypassed																																										
1	0	1	1	filter bypassed + delay in Y channel of 1T																																										
1	1	0	8	filter 5 $(1/16 (1 + 3z^{-1} + 3z^{-2} + z^{-3} + z^{-4} + 3z^{-5} + 3z^{-6} + z^{-7}))$																																										
1	1	1	4	$(1/8 (1 + 3z^{-1} + 3z^{-2} + z^{-3}))$																																										
"05 and 08" YD9 to YD0	Line number per output field (straight binary): 00 0000 0000 to 11 1111 1111 (number of YS lines as a maximum)																																													

Digital video scaler

SAA7186

<p>"06 and 08" YS9 to YS0</p>	<p>Line number per input field (straight binary):                  00 0000 0000      0 line                  11 1111 1111      1023 lines (maximum = number of lines/field - 3)</p>															
<p>"07 and 08" YO8 to YO0</p>	<p>Vertical start of scaling window. "0" equals 3rd line after rising slope of VS input signal. Take care of active line number per field (straight binary).                  0 0000 0000    start with 3rd line after the rising slope of VS                  0 0000 0011    start with 1st line after the falling slope of nominal VS (SAA7151B/91B)                  1 1111 1111    511 + 3 lines after the rising slope of VS (maximum value)</p>															
<p>"08" AFS</p>	<p>Adaptive filter switch:    0 = off; use VP1, VP0 and HF2 to HF0 bits                  1 = on; filter characteristics are selected by the scaler</p>															
<p>VP1 to VP0</p>	<p>Vertical data processing</p> <table border="1" data-bbox="440 649 1180 770"> <thead> <tr> <th>VP1</th> <th>VP0</th> <th>processing</th> </tr> </thead> <tbody> <tr> <td>0</td> <td>0</td> <td>bypassed</td> </tr> <tr> <td>0</td> <td>1</td> <td>delay of one line <math>H(z) = z^{-1}</math></td> </tr> <tr> <td>1</td> <td>0</td> <td>vertical filter 1: <math>(H(z) = 1/2 (1 + z^{-1}))</math></td> </tr> <tr> <td>1</td> <td>1</td> <td>vertical filter 2: <math>(H(z) = 1/4 (1 + 2z^{-1} + z^{-2}))</math></td> </tr> </tbody> </table>	VP1	VP0	processing	0	0	bypassed	0	1	delay of one line $H(z) = z^{-1}$	1	0	vertical filter 1: $(H(z) = 1/2 (1 + z^{-1}))$	1	1	vertical filter 2: $(H(z) = 1/4 (1 + 2z^{-1} + z^{-2}))$
VP1	VP0	processing														
0	0	bypassed														
0	1	delay of one line $H(z) = z^{-1}$														
1	0	vertical filter 1: $(H(z) = 1/2 (1 + z^{-1}))$														
1	1	vertical filter 2: $(H(z) = 1/4 (1 + 2z^{-1} + z^{-2}))$														
<p>"09 and 0B" VS8 to VS0</p>	<p>Vertical bypass start, sets begin of the bypass region (straight binary). Scaling region overrides bypass region (YO bits):                  0 0000 0000    start with 3rd line after the rising slope of VS                  0 0000 0011    start with 1st line after the falling slope of nominal VS (SAA7151B/91B)                  1 1111 1111    511 + 3 lines after the rising slope of VS (maximum value)</p>															
<p>"0A and 0B" VC8 to VC0</p>	<p>Vertical bypass count, sets length of bypass region (straight binary):                  0 0000 0000    0 line length                  1 1111 1111    511 lines length (maximum = number of lines/field - 3)</p>															
<p>TCC</p>	<p>Two's complement input data select (U, V):      0 = binary input data                  1 = two's complement input data</p>															
<p>POE</p>	<p>Polarity, internally detected odd/even flag O/E:                  0 = flag unchanged;      1 = flag inverted</p>															
<p>"0C" VL7 to VL0</p>	<p>Set lower limit for V colour-difference signal (8 bit; two's complement):                  1000 0000      as maximum negative value = -128 signal level                  0000 0000      limit = 0                  0111 1111      as maximum positive value = +127 signal level</p>															
<p>"0D" VU7 to VU0</p>	<p>Set upper limit for V colour-difference signal (8 bit; two's complement):                  1000 0000      as maximum negative value = -128 signal level                  0000 0000      limit = 0                  0111 1111      as maximum positive value = +127 signal level</p>															



## Digital video scaler

SAA7186

"0E" UL7	to	UL0	Set lower limit for U colour-difference signal (8 bit; two's complement): 1000 0000 as maximum negative value = -128 signal level 0000 0000 limit = 0 0111 1111 as maximum positive value = +127 signal level
"0F" UU7	to	UU0	Set upper limit for U colour-difference signal (8 bit; two's complement): 1000 0000 as maximum negative value = -128 signal level 0000 0000 limit = 0 0111 1111 as maximum positive value = +127 signal level
"10" MCT			Monochrome and two's complement output data select: 0 = inverse grayscale luminance (if grayscale is selected by FS bits) or straight binary U, V data output 1 = non-inverse monochrome luminance (if grayscale is selected by FS bits) or two's complement U, V data output
QPL			Line qualifier polarity flag : 0 = LNQ is active-LOW (pin 1 and on VRO1, pin 99); 1 = LNQ is active-HIGH
QPP			Pixel qualifier polarity flag : 0 = PXQ is active-LOW (VRO0, pin 100); 1 = PXQ is active-HIGH
TTR			Transparent data transfer: 0 = normal operation (VRAM protocol valid,) 1 = FIFO register transparent (output FIFO in shift register mode)
EFE			Extended formats enable, FS-bits in subaddress "00"

Digital video scaler

SAA7186

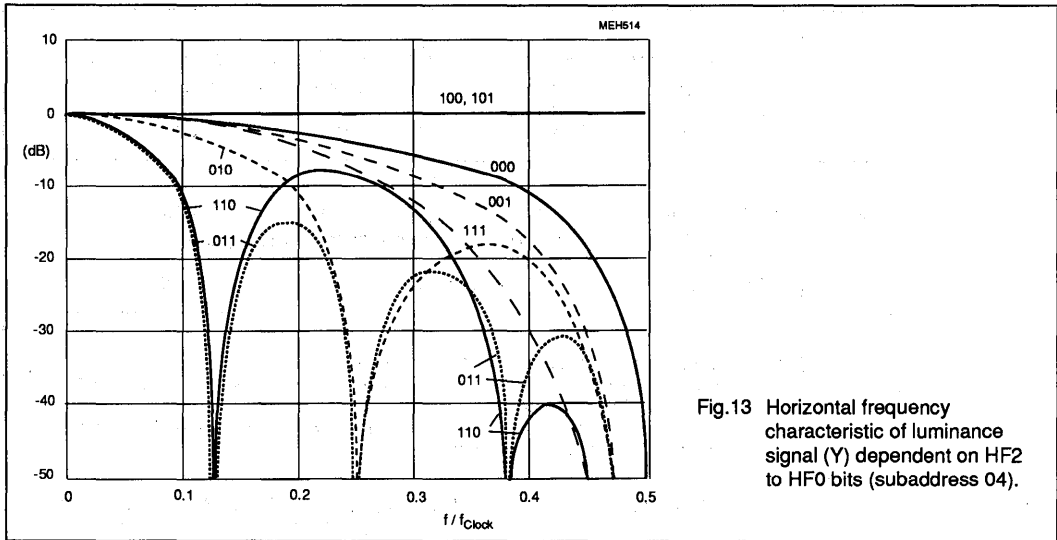

Fig.13 Horizontal frequency characteristic of luminance signal (Y) dependent on HF2 to HF0 bits (subaddress 04).

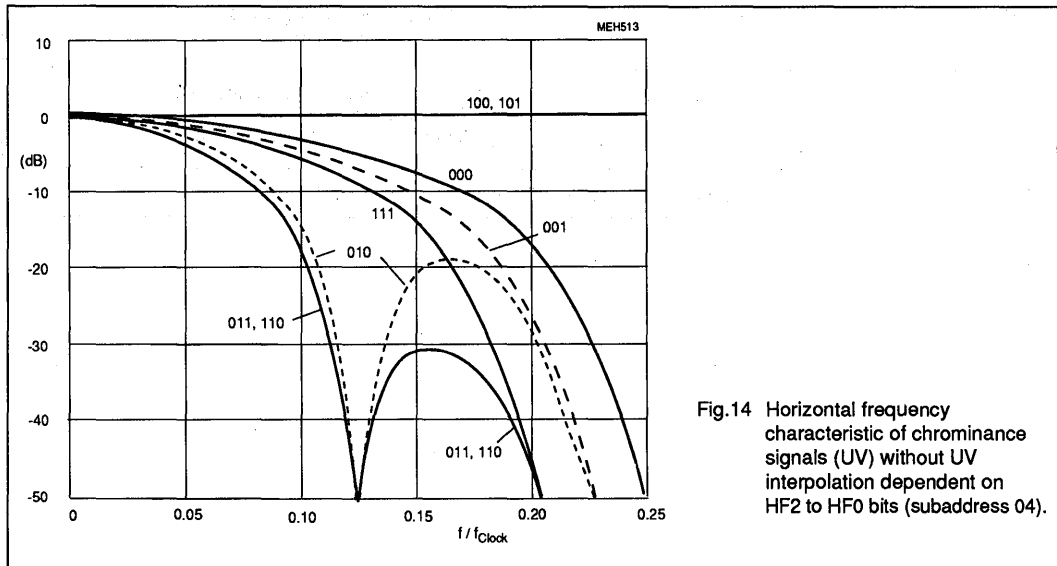
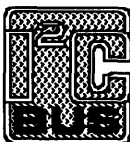

Fig.14 Horizontal frequency characteristic of chrominance signals (UV) without UV interpolation dependent on HF2 to HF0 bits (subaddress 04).



Purchase of Philips' I<sup>2</sup>C components conveys a license under the Philips' I<sup>2</sup>C patent to use the components in the I<sup>2</sup>C-system provided the system conforms to the I<sup>2</sup>C specifications defined by Philips.

## Digital video scaler

SAA7186

**10. LIMITING VALUES**

In accordance with the Absolute Maximum Rating System (IEC 134).

SYMBOL	PARAMETER	MIN.	MAX.	UNIT
$V_{DD}$	supply voltage (pins 5, 14, 26, 40, 55, 67, 76 and 91)	-0.5	6.5	V
$V_I$	DC input voltage on all pins	-0.5	$V_{DD}$	V
$I_{DD}$	supply current (pins 5, 14, 26, 40, 55, 67, 76 and 91)	-	70	mA
$P_{tot}$	total power dissipation	0	1	W
$T_{stg}$	storage temperature range	-65	150	°C
$T_{amb}$	operating ambient temperature range	0	70	°C
$V_{ESD}$	electrostatic handling* for all pins	-	±2000	V

\* Equivalent to discharging a 100 pF capacitor through a 1.5 kΩ series resistor.

**11. DC CHARACTERISTICS** $V_{DD1}$  to  $V_{DD8}$  = 4.5 to 5.5 V;  $T_{amb}$  = 0 to 70 °C unless otherwise specified.

SYMBOL	PARAMETER	CONDITIONS	MIN.	TYP.	MAX.	UNIT
$V_{DD}$	supply voltage range (pins 5, 14, 26, 40, 55, 67, 76 and 91)		4.5	5	5.5	V
$I_P$	total supply current ( $I_{DD1} + I_{DD2} + I_{DD3} + I_{DD4} + I_{DD5} + I_{DD6} + I_{DD7} + I_{DD8}$ )	inputs LOW and outputs without load	-	80	-	mA
<b>Data and control inputs</b>						
$V_{IL}$	input voltage LOW		-0.5	-	0.8	V
$V_{IH}$	input voltage HIGH		2.0	-	$V_{DD}+0.5$	V
$I_{LI}$	input leakage current	$V_{IL} = 0$	-	-	10	μA
$C_I$	input capacitance	data	-	-	8	pF
		clocks	-	-	10	pF
<b>Data and control outputs</b>						
$V_{OL}$	output voltage LOW	note 1	-	-	0.6	V
$V_{OH}$	output voltage HIGH	note 1	2.4	-	-	V
<b>3-state outputs</b>						
$I_{O\ off}$	high-impedance output current		-	-	±5	μA
$C_O$	high-impedance output capacitance		-	-	8	pF
<b>I<sup>2</sup>C-bus, SDA and SCL (pins 44 and 45)</b>						
$V_{IL}$	input voltage LOW		-0.5	-	1.5	V
$V_{IH}$	input voltage HIGH		3	-	$V_{DD}+0.5$	V
$I_{44, 45}$	input current		-	-	±10	μA
$I_{ACK}$	output current on pin 44	acknowledge	3	-	-	mA
$V_{OL}$	output voltage at acknowledge	$I_{44} = 3$ mA	-	-	0.4	V

## Digital video scaler

SAA7186

**12. AC CHARACTERISTICS** $V_{DD1}$  to  $V_{DD8} = 4.5$  to  $5.5$  V;  $T_{amb} = 0$  to  $60$  °C unless otherwise specified.

SYMBOL	PARAMETER	CONDITIONS	MIN.	TYP.	MAX.	UNIT
<b>LLC timing</b> (pin 36)		Fig.11				
$t_{LLC}$	cycle time		31	-	45	ns
$t_p$	pulse width (duty factor)	$t_{LLC H} / t_{LLC}$	40	50	60	%
$t_r$	rise time		-	-	5	ns
$t_f$	fall time		-	-	6	ns
<b>Input data and CREF timing</b>		Fig.15				
$t_{SU}$	setup time		11	-	-	ns
$t_{HD}$	hold time		3	-	-	ns
<b>VCLK timing</b> (pin 51)		Fig.16				
$t_{VCLK}$	VRAM port clock cycle time	note 2	50	-	200	ns
$t_{pL}, t_{pH}$	LOW and HIGH times	note 3	17	-	-	ns
$t_r$	rise time		-	-	5	ns
$t_f$	fall time		-	-	6	ns
<b>Output data and reference signal timing</b>		Figures 15 and 16				
$C_L$	load capacitance	VRO outputs other outputs	15 7.5	- -	40 25	pF pF
$t_{OH}$	VRO data hold time	$C_L = 10$ pF; note 4	0	-	-	ns
$t_{OHL}$	related to LLC (INCADR, HFL)	$C_L = 10$ pF; note 5	0	-	-	ns
$t_{OHV}$	related to VCLK (HFL)	$C_L = 10$ pF; note 5	0	-	-	ns
$t_{OD}$	VRO data delay time	$C_L = 40$ pF; note 4	-	-	25	ns
$t_{ODL}$	related to LLC (INCADR, HFL)	$C_L = 25$ pF; note 5	-	-	60	ns
$t_{ODV}$	related to VCLK (HFL)	$C_L = 25$ pF; note 5	-	-	60	ns
$t_D$	output disable time to 3-state	$C_L = 40$ pF; note 6	-	-	40	ns
$t_E$	output enable time from 3-state	$C_L = 40$ pF; note 6	-	-	40	ns
$t_{HFL VOE}$	HFL maximum response time	VRAM port enabled	-	-	810	ns
$t_{HFL VCLK}$	HFL maximum response time	HFL set at beginning of VCLK burst	-	-	840	ns

**Notes to the characteristics**

- Levels are measured with load circuit. VRO outputs with  $1.2$  k $\Omega$  in parallel to  $25$  pF at  $3$  V (TTL load).
- Maximum  $t_{VCLK} = 200$  ns for test mode only. The applicable maximum cycle time depends on data format, horizontal scaling and input data rate.
- Measured at  $1.5$  V level;  $t_{pL}$  may be unlimited.
- Timings of VRO refer to the rising edge of VCLK.
- The timing of INCADR refers to LLC; the rising edge of HFL always refers to LLC. During a VRAM transfer is the falling edge of HFL generated by VCLK. Both edges of HFL refer to LLC during horizontal increment and vertical reset cycles.
- Asynchronous signals with timing referring to the  $1.5$  V switching point of VOEN input signal (pin 50).

Digital video scaler

SAA7186

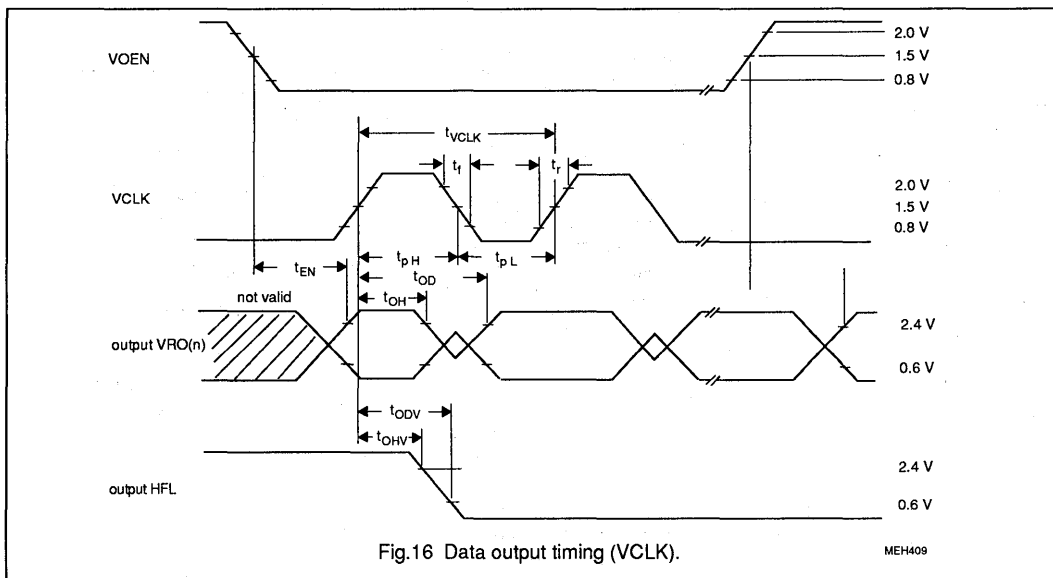
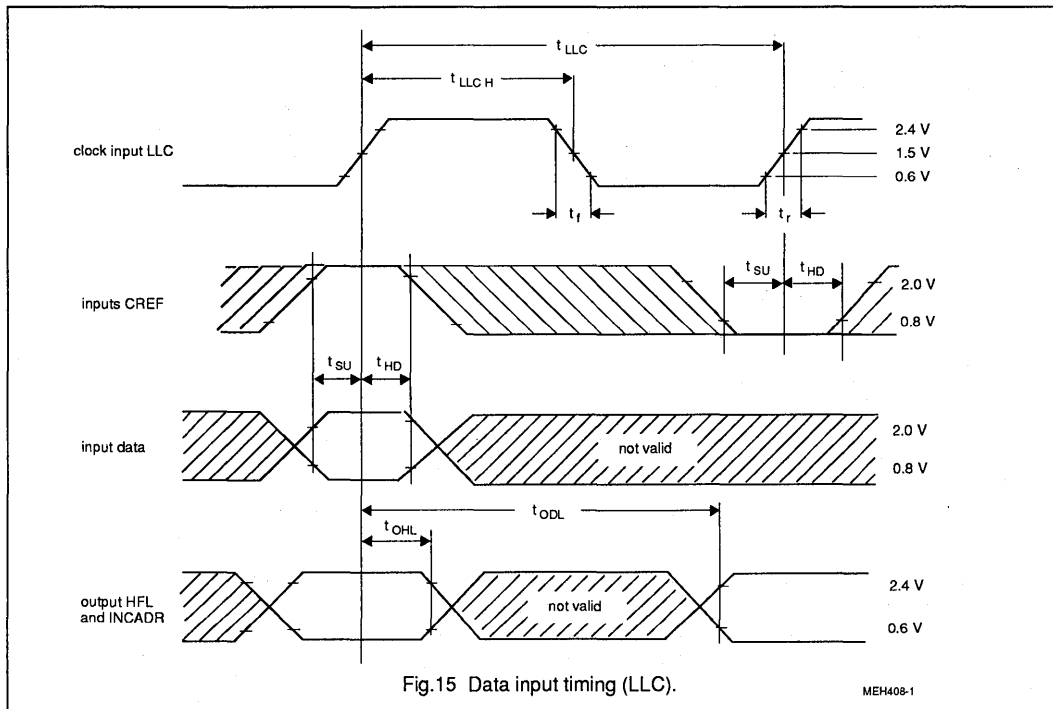

## Digital video scaler

SAA7186

## 13. PROCESSING DELAYS

PORTS	DELAY IN LLC	REMARKS*
YIN to VRO	58	in transparent mode only
UVIN to VRO	58	in transparent mode only
HREF to VRO	58	in transparent mode only

## 14. PROGRAMMING EXAMPLE

Slave address byte is B8h at pin IICSA = 0 (or BCh at pin IICSA = +5 V).

This example shows the setting via I<sup>2</sup>C-bus for the processing of a picture segment at 1:1 horizontal and vertical scale.

Values in brackets [...]:

if no scaling or panning is wanted,

the parameters XD, XS, YD and YS should be set to the maximum value 3FFh.

the parameters XO and YO should be set to the minimum value 000h.

(in this case, HREF and VS from external define the SAA7186 processing window).

SUBADDR (hex)	BITS	FUNCTION	VALUE (hex)	COMMENT
00	RTB, OF(1:0), VPE, LW(1:0), FS(1:0),	ROM table control and field sequence processing; VRAM port enable; output format select	11	(1)
01	XD(7:0)	LSB's output pixel/line	80 [FF]	384 pixels out
02	XS(7:0)	LSB's input pixel/line	80 [FF]	384 pixels in
03	XO(7:0)	LSB's for horizontal window start	10 [00]	1st pixel after HREF = 1
04	HF(2:0), XO(8),	horizontal filter select and MSB's of subaddresses 01, 02, 03	85 [8F]	horizontal filter bypassed
05	XS(9, 8), XD(9, 8)	LSB's output lines/field	90 [FF]	144 lines out
06	YD(7:0)	LSB's input lines/field	90 [FF]	144 lines in
07	YS(7:0)	LSB's vertical window start	03 [00]	1st line after VS = 0; (2)
08	AFS, VP(1:0), YO(8),	adaptive and vertical filter select; MSB's of subaddresses 05, 06, 07	00 [FF]	no adaptive select
09	YS(9, 8), YD(9, 8)	LSB's vertical bypass start position	00	vertical filter bypassed
0A	VS(7:0)	LSB's vertical bypass lines/field	00	not bypassed
0B	VC(7:0)	MSB's of subaddresses 09, 0A;	00	region
0B	VS(8), VC(8), TCC, POE	UV input data representation and odd/even polarity switch	00	defined; (3) (4)
0C	VL(7:0)	UV keyer: lower limit V (R-Y)	00	) keying is switched off
0D	VU(7:0)	UV keyer: upper limit V (R-Y)	FF	) by VU < VL
0E	UL(7:0)	UV keyer: lower limit U (B-Y)	00	-
0F	UU(7:0)	UV keyer: upper limit U (B-Y)	00	-
10	MCT, QPP, QPL, TTR, EFE	Y or UV output data representation, output data transfer mode, pixel/line qualifier polarity.	00	(5)

---

**Digital video scaler****SAA7186**

---

**Notes to the programming examples**

- (1) RTB = 0    ROM table is active (only for RGB formats)  
    OF = 00    SAA7186 processes the both fields for interlaced display  
    VPE = 1    VRAM port is enabled  
    LW = 00    longword position of first pixel in each output line = 0  
    FS = 01    16-bit 4:2:2 YUV output format is selected
- (2) for nominal VS length of 6 x H-period (input SAA7191B respectively SAA7151B with active VNL)
- (3) TTC = 0    straight binary UV input data expected
- (4) odd/even polarity unchanged - can be used to change the field sequence if phase relations between HREF and VS are not according to SAA7191B respectively SAA7151B specification
- (5) MCT = 0    when EFE, FS = 001h: UV output data are straight binary  
    QPP = 0    the pixel qualifier PXQ is "0"-active (if TTR, EFE = 1)  
    QPL = 0    line qualifier LNQ is "0"-active (if TTR, EFE = 1)  
    TTR = 0    VRAM port is set to data burst transfer  
    EFE = 0    32-bit longword formats selected.

## Digital video encoder (DENC2-SQ)

SAA7187

## FEATURES

- Monolithic CMOS 5V device
- Digital PAL/NTSC encoder
- System Pixel Frequency selectable for 12.27 MHz (60 Hz fields) or 14.75 MHz (50 Hz fields)
- 24-bit wide YUV Input port or
- 16-bit wide YUV Input port or
- Input data format Cb,Y,Cr,Y,... (CCIR 656 like)
- IIC Bus control port
- MPU parallel control port
- Encoder can be master or slave
- Programmable horizontal and vertical input synchronization phase
- Programmable horizontal sync output phase
- OSD overlay with LUTs (8\*3 bytes)
- 'Line 21' Closed Caption encoder
- Cross colour reduction
- DACs running at two times oversampling with 10 bits resolution
- Controlled rise-/fall times of output syncs and blanking
- Down mode of DACs
- CVBS and S-Video output simultaneously.
- PLCC68 package

## Quick Reference Data

SYMBOL	PARAMETER	MIN.	TYP.	MAX.	UNIT
V <sub>DDD</sub>	digital supply voltage range	4.5	5.0	5.5	V
V <sub>DDA</sub>	analog supply voltage range	4.75	5.0	5.25	V
I <sub>DDD</sub>	supply current digital	-	175	210	mA
I <sub>DDA</sub>	supply current analog	-	50	55	mA
V <sub>i</sub>	input signal levels	TTL - compatible			V
V <sub>o</sub>	analog output signals, Y, C and CVBS without load (peak to peak value)	-	2	-	V
R <sub>L</sub>	load resistance	80	-	-	Ω
ILE	LF integral linearity error	-	-	± 2	LSB
DLE	LF differential linearity error	-	-	± 1	LSB
T <sub>amb</sub>	operating ambient temperature range	0	-	70	°C

## General Description

The Digital Video Encoder 2 (DENC2-SQ) encodes digital YUV video data to an NTSC or PAL CVBS or S-Video signal.

The circuit accepts differently formatted YUV data with 640 or 768 active pixels per line. It includes a sync/clock generator as well as on chip D/A converters.

The circuit is compatible to the DIG. TV2 chip family (Square Pixel).

EXTENDED TYPE NUMBER	PACKAGE			
	PINS	PIN POSITION	MATERIAL	CODE
SAA7187	68	PLCC	plastic	SOT188



Digital video encoder (DENC2-SQ)

SAA7187

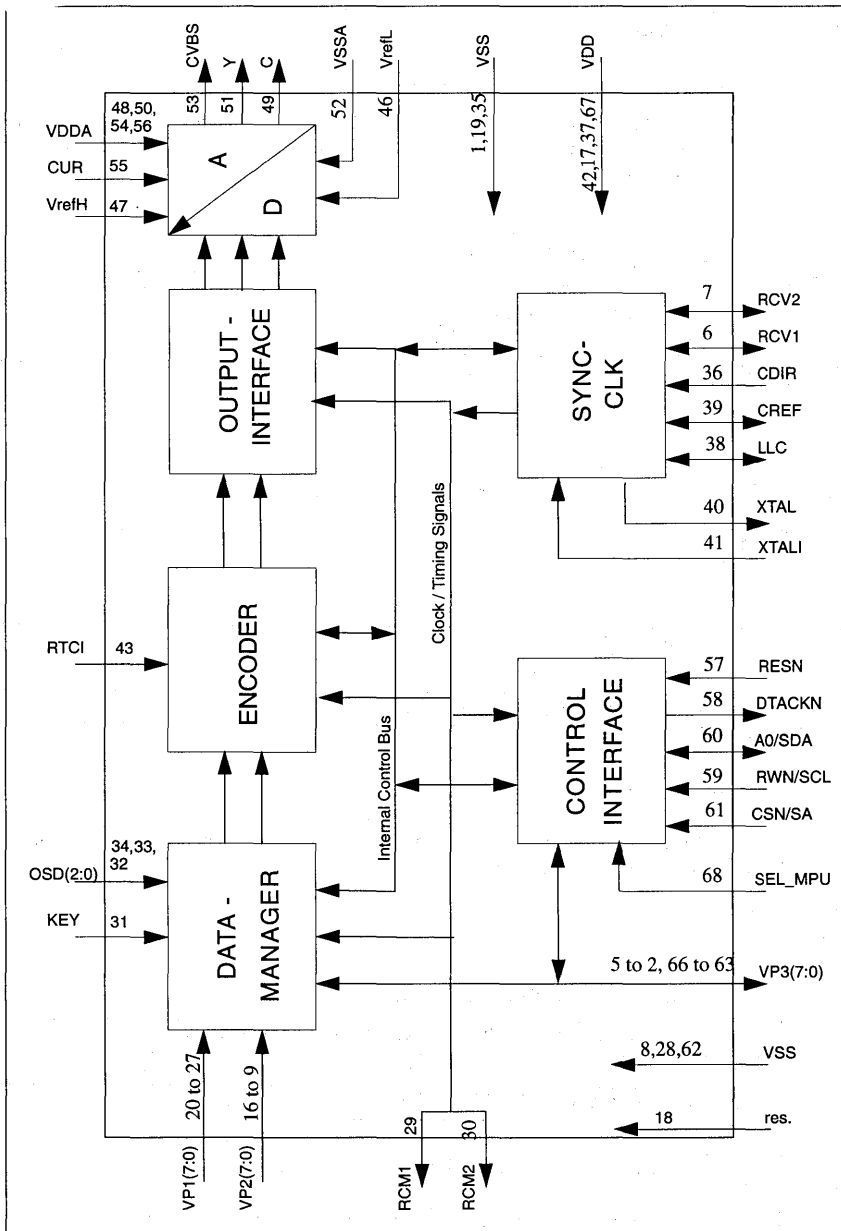

## Digital video encoder (DENC2-SQ)

SAA7187

## PINNING

SYMBOL	PIN	DESCRIPTION
VSS	1	Digital negative supply voltage (Ground)
VP3(4)	2	Upper 4 bits of the VP3 Port. If Pin 68 (SEL_MPU) is high, this is the data bus of the parallel MPU interface. If it is low, there can be multiplexed UV lines (422) or the U-signal (444) of the Video input
VP3(5)	3	
VP3(6)	4	
VP3(7)	5	
RCV1	6	Raster Control 1 for Video port. Depending on the synchronization mode, this pin receives/provides a VS/FS/FSEQ signal.
RCV2	7	Raster Control 2 for Video port. Depending on the synchronization mode, this pin receives/provides a HS/HREF/CBL signal
VSS	8	Digital negative supply voltage (Ground)
VP2(0)	9	Video Port VP2. In 444 input mode, this is input for the V-signal
VP2(1)	10	
VP2(2)	11	
VP2(3)	12	
VP2(4)	13	
VP2(5)	14	
VP2(6)	15	
VP2(7)	16	
VDD	17	Digital positive supply voltage.
res.	18	reserved, do not connect.
VSS	19	Digital negative supply voltage (Ground)
VP1(7)	20	Video Port VP1. This is an input for CCIR-656 compatible, multiplexed video data, or during other input modes, this is the Y-signal.
VP1(6)	21	
VP1(5)	22	
VP1(4)	23	
VP1(3)	24	
VP1(2)	25	
VP1(1)	26	
VP1(0)	27	
VSS	28	Digital negative supply voltage (Ground)
RCM1	29	Raster Control Master 1. This pin provides a VS/FS/FSEQ signal
RCM2	30	Raster Control Master 2. This pin provides a programmable HS pulse
KEY	31	Key signal for OSD. It is high-active.
OSD(0)	32	On Screen Display data. This is the index for the internal OSD lookup table.
OSD(1)	33	
OSD(2)	34	
VSS	35	Digital negative supply voltage (Ground)
CDIR	36	Clock direction. If the CDIR input is high, the circuit receives a clock signal, otherwise LLC and CREF are generated by the internal crystal oscillator.
VDD	37	Digital positive supply voltage.

## Digital video encoder (DENC2-SQ)

SAA7187

## PINNING

SYMBOL	PIN	DESCRIPTION
LLC	38	Line Locked clock. This is the 24.54 MHz / 29.5 MHz master clock for the encoder. The direction is set by the CDIR pin.
CREF	39	Clock Reference signal. This is the clock qualifier for DIG-TV2 compatible signals.
XTAL	40	Crystal oscillator output (to crystal).
XTALI	41	Crystal oscillator input (from crystal). If the oscillator is not used, this pin should be connected to ground.
VDD	42	Digital positive supply voltage.
RTCI	43	Real Time Control Input. If the clock is provided by a SAA7191B, RTCI should be connected to the RTCO pin of the decoder to improve the signal quality.
AP	44	Test pin. Connect to digital ground for normal operation.
SP	45	Test pin. Connect to digital ground for normal operation.
VREFL	46	Lower reference voltage for the D/A converters.
VREFH	47	Upper reference voltage for the D/A converters.
VDDA	48	Analog positive supply voltage for the D/A converters and output amplifiers.
C	49	Analog output of the chrominance signal.
VDDA	50	Analog positive supply voltage for the D/A converters and output amplifiers.
Y	51	Analog output of the luminance signal.
VSSA	52	Analog negative supply voltage for the D/A converters and output amplifiers (Ground).
CVBS	53	Analog output of the CVBS signal.
VDDA	54	Analog positive supply voltage for the D/A converters and output amplifiers.
CUR	55	Current input for the output amplifiers, connect 15 kOhm to VDDA
VDDA	56	Analog positive supply voltage for the D/A converters and output amplifiers.
RESN	57	Reset input, low active. After reset is applied, all outputs are in tristate/input mode. The IIC receiver waits for the start condition.
DTACKN	58	Data acknowledge output of the parallel MPU interface; low-active, otherwise high-impedance.
RWN/SCL	59	If pin 68 (SEL_MPU) is high, this is the read/write signal of the parallel MPU interface, otherwise it is the IIC serial clock line.
A0/SDA	60	If pin 68 (SEL_MPU) is high, this is the address signal of the parallel MPU interface, otherwise it is the IIC serial data line.
CSN/SA	61	If pin 68 (SEL_MPU) is high, this is the chip select signal of the parallel MPU interface, otherwise it is the IIC slave address select pin: Low : Slave address = 88h; High : Slave address = 8Ch
VSS	62	Digital negative supply voltage (Ground)
VP3(0)	63	Lower 4 bits of the VP3 Port. If Pin 68 (SEL_MPU) is high, this is the data bus of the parallel MPU interface. If it is low, there can be multiplexed UV lines (422) or the U-signal (444) of the Video input
VP3(1)	64	
VP3(2)	65	
VP3(3)	66	
VDD	67	Digital positive supply voltage.
SEL_MPU	68	Select MPU interface. If it is high, the parallel MPU interface is active, otherwise the IIC bus interface will be used.

Digital video encoder (DENC2-SQ)

SAA7187

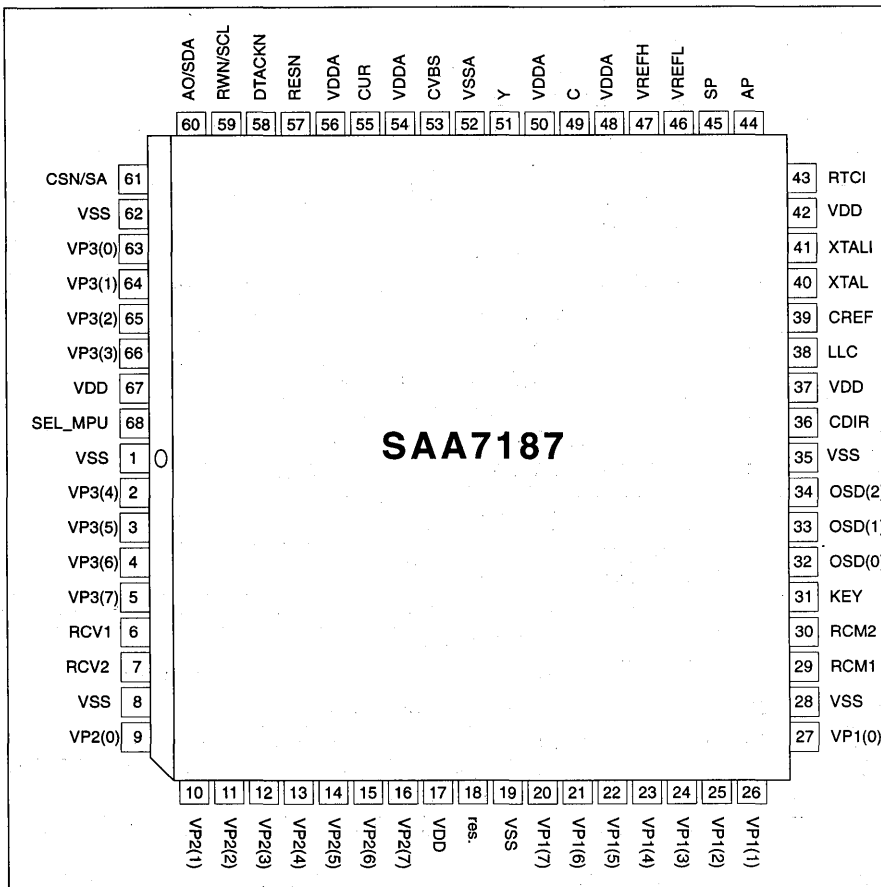

Fig. 2: Pinning Diagram

Functional Description

The digital Video Encoder (DENC2-SQ) encodes digital luminance and chrominance into analog CVBS- and simultaneously S - Video (Y/C) signals. NTSC-M and PAL B/G standards as well as sub-standards are supported.

The basic encoder function consists of subcarrier generation and colour modulation as well as insertion of synchronization signals. Luminance and chrominance signals are filtered according to the standard requirements RS-170-A and CCIR-624.

For ease of analog post filtering the signals are two times oversampled w.r.t. pixel clock before digital-to-analog conversion.

For total filter transfer characteristics see figs 3, 4, 5 and 6 for 60 Hz field rate, and figs 7, 8, 9 and 10 for 50 Hz field rate. The DACs are realized with full 10 bit resolution. The encoder provides three 8 bit wide data ports; that serve different applications.

The VP1 port accepts 8 lines multiplexed Cb-Y-Cr data (CCIR-656 mode), or Y-data only (444 mode).

The VP2 port accepts Cr-data in 444 input mode.

The VP3 port accepts Cb-data (444 input mode) or multiplexed Cb/Cr-data (422 input mode). If not used for video input data, it also can handle the data of an 8 bit wide microprocessor interface, alternatively.

Minimum suppression of output chroma alias components around 1 MHz due to high frequency 444 input data is better than 12 dB.

The 8 bit multiplexed Cb-Y-Cr formats are CCIR-656 (D1 format) compatible, but the SAV, EAV e.t.c. codes are not decoded.

A crystal-stable master clock (LLC) of 24.54 or 29.5 MHz, which is twice the linclocked pixel clock, needs to be sup-

# Digital video encoder (DENC2-SQ)

# SAA7187

plied externally. Optionally, a crystal oscillator input/output pair of pins and an on-chip clock driver is provided. Additionally, a DMSD2 compatible clock interface, using CREF (input or output) and RTC (see data sheet SAA 7191B) is available.

The DENC2-SQ synthesizes all necessary internal signals, colour subcarrier frequency, as well as synchronization signals, from that clock. DENC2-SQ can be timing master or slave.

The IC contains Closed Caption and Extended Data Services Encoding (Line 21); it also supports OSD via KEY and three bit overlay techniques by a 24\*8 LUT.

The IC can be programmed via I2C or 8-bit MPU interface, but only one interface configuration can be active at a time; if 422 or 444 input format is being used, only the I2C interface can be selected.

A lot of possibilities is provided for setting of different video parameters like Black- and Blanking level control, colour subcarrier frequency, variable burst amplitude etc.

During Reset (RESN=low) and after Reset released, all digital I/O stages are set to input mode. A Reset forces the control interfaces to abort any running bus transfer and to set register 3Ah to contents 00h, register 61h to contents 15h, and register 6Ch to contents 00h. All other control registers are not influenced by a Reset.

## Data Manager

In the Data Manager, the de-multiplexing scheme is chosen acc. to the input format.

Depending on hardware conditions (signals on pins KEY and OSD(2-0), and software programming either data from the VP ports or from the OSD port are selected to be encoded to CVBS and Y/C signals.

Optionally, the OSD colour look-up tables located in this block, can be read out in a pre-defined sequence (8 steps per active video line), achieving e.g. a colour bar test pattern generator without need for an external data source. The colour bar function is under software control, only.

## Encoder

### Video Path:

The encoder generates out of Y,U,V base band signals output signals luminance and colour subcarrier, suitable for use as CVBS or separate Y and C signals.

Luminance is modified in gain as well as in offset (latter programmable in a certain range to enable different black level set-ups). After having been inserted a fixed sync level, acc. to standard composite sync schemes, a variable blanking level, programmable also in a certain range, is inserted.

Transients of both sync pulses and start/stop of blanking are reduced compared to overall luminance bandwidth.

In order to enable easy analog post filtering, luminance is interpolated from square pixel data rate to twice that rate (24.54 or 29.5 MHz, respectively), providing luminance in 10 bit resolution. For transfer characteristic of the luminance interpolation filter see figs. 5 and 6 for 60 Hz field rate and figs. 9 and 10 for 50 Hz field rate.

Chrominance is modified in gain (programmable separately for U and V), standard dependent burst is inserted, before base band colour signals are interpolated properly to 24.54/29.5 MHz data rate. One of the interpolation stages can be by-passed, thus providing a higher colour bandwidth, which can be made use of for Y/C output. For transfer characteristics of the chrominance interpolation filter see figs. 3 and 4 for 60 Hz field rate and figs. 7 and 8 for 50 Hz field rate.

The amplitude of inserted burst is programmable in a certain range, suitable for standard signals as well as for special effects. Behind the succeeding quadrature modulator, colour in 10 bit resolution is provided on subcarrier.

The numeric ratio between Y and C output is acc. to standards.

### Closed Caption Encoder:

By means of this circuit, data acc. to the specification of Closed Caption or Extended Data Service, delivered by the control interface, can be encoded (LINE21). Two dedicated pairs of bytes (two bytes per field), each pair preceded by run-in clocks and framing code, are possible.

The actual line number where data are to be encoded in, can be modified in a certain range.

Data clock frequency is acc. to definition for NTSC-M standard 32 times horizontal line frequency.

Data LOW at the output of the DACs corresponds to 0 IRE, data HIGH at the output of the DACs corresponds to about 50 IRE.

It is also possible to encode Closed Caption Data for 50 Hz field frequencies at 32 times horizontal line frequency.

## Output Interface

In the output interface encoded Y and C signals are converted from digital to analog in 10 bit resolution both. Y and C signals are combined to a 10 bit wide CVBS-signal, as well; in front of the summation point, the luminance signal can optionally be fed through a further filter stage, suppressing components in the range of subcarrier frequency. Thus, a kind of Cross Colour reduction is provided, useful in a standard TV set with CVBS input.

Slopes of synchronization pulses are not affected with any Cross Colour reduction active.

Three different filter characteristics or bypass are available, see fig. 5 for 60 Hz field rate and fig. 9 for 50 Hz field rate.

The CVBS output occurs with the same processing delay as the Y,C outputs do. Absolute amplitudes at the input of the DAC for CVBS is reduced by 15/16 w.r.t. Y- and C- DACs to make optimized use of conversion ranges.

Outputs of all DACs can be set together via software control to minimum output voltage for either purpose.

## Synchronization

The synchronization of the DENC2-SQ is able to operate in two modes:

In the slave mode, the circuit accepts sync pulses at the bi-directional RCV1 port. The timing and trigger behaviour related to the video signal on VP ports can be influenced by programming the polarity and on-chip delay of RCV1. Active slope of RCV1 defines the vertical phase and optionally the odd/even- and colour frame phase to be initialized, it can be used also to set the horizontal phase.

# Digital video encoder (DENC2-SQ)

SAA7187

If the horizontal phase shall not be influenced by RCV1, a horizontal pulse needs to be supplied at the RCV2 pin. Timing and trigger behaviour can be influenced for RCV2, as well.

If there are missing pulses at RCV1 and/or RCV2, the time base of DENC2-SQ runs free, thus an arbitrary number of sync slopes may miss, but no additional pulses (such with wrong phase) must occur.

If the vertical and horizontal phase is derived from RCV1, RCV2 can be used for horizontal or composite blanking input or output.

In the master mode, the time base of the circuit runs free continuously. On the RCV1 port, the IC can output:

- a Vertical Sync signal (VS) with 3 or 2.5 lines duration, or
- an ODD/EVEN signal which is low in odd fields, or
- a field sequence signal (FSEQ) which is high in the first of 4 resp. 8 fields.

On the RCV2 port, the IC can provide a horizontal pulse with programmable start and stop phase; this pulse can be inhibited in the vertical blanking period to build up e.g. a composite blanking signal.

The phase of the pulses output on RCV1 or RCV2 are related on the VP ports, polarity of both signals is selectable.

On the RCM1 port the same types of signals as on RCV1 (as output) are available; on RCM2 the IC provides a horizontal pulse with programmable start and stop phase.

The length of a field as well as start and end of its active part can be programmed. The active part of a field always starts at the beginning of a line.

## Control Interface

DENC2-SQ contains two control interfaces: An IIC slave transceiver and 8 bit parallel microprocessor interface. The interfaces cannot be used simultaneously.

The IIC bus interface is a standard slave transceiver, supporting 7 bit slave addresses and 100  $\text{kBit/sec}$  guaranteed transfer rate. It uses 8 bit subaddressing with auto-increment function. All registers are write-only, except one readable status byte.

Two IIC slave addresses can be selected (pin SEL\_MPU must be low!):

88h: Low at pin 61

8Ch: High at pin 61

The parallel interface is defined by

D(7-0) data bus

CSN low-active chip select signal

RWN read/write not signal, low for a write cycle

DTACKN 680XX style data acknowledge (hand-shake), active low

A0 register select, low selects address, high selects data

The parallel interface uses two registers, one auto-incremental containing the current address of a control register (equals subaddress with IIC control), one containing actual data. The currently addressed register is mapped to the corresponding control register.

Via a read access to the address register, the status byte can be read optionally; no other read access is provided.

## Input levels and formats

DENC2-SQ expects digital YUV data with levels (digital codes) acc to CCIR601:

Deviating amplitudes of the colour difference signals can be compensated by independent gain control setting, while gain for luminance is set to pre-defined values, distinguishable for 7.5 IRE setup or without setup.

Reference levels are measured with a colour bar, 100% white, 100% amplitude, 100% saturation.

When the IC is operating with input data acc. to CCIR656, programming can be done alternatively via the parallel interface using VP3 port for data transfer.

For other input modes, the IIC interface has to be used for programming.

## Digital video encoder (DENC2-SQ)

SAA7187

## CCIR signal component levels

Signal	IRE	dig. level	Code
Y	0	16	straight binary
	50	126	
	100	235	
Cb	bottom peak	16	straight binary
	colourless	128	
	top peak	240	
Cr	bottom peak	16	straight binary
	colourless	128	
	top peak	240	

## The 8 bit multiplexed format (CCIR656 like)

Time	0	1	2	3	4	5	6	7
Sample	Cb <sub>0</sub>	Y <sub>0</sub>	Cr <sub>0</sub>	Y <sub>1</sub>	Cb <sub>2</sub>	Y <sub>2</sub>	Cr <sub>2</sub>	Y <sub>3</sub>
Lum. pixel number	0		1		2		3	
Colour pixel number	0				2			

## The 16 bit multiplexed format (DTV2 format)

Time	0	1	2	3	4	5	6	7
Sample Y - line	Y <sub>0</sub>		Y <sub>1</sub>		Y <sub>2</sub>		Y <sub>3</sub>	
Sample UV - line	Cb <sub>0</sub>		Cr <sub>0</sub>		Cb <sub>2</sub>		Cr <sub>2</sub>	
Lum. pixel number	0		1		2		3	
Colour pixel number	0				2			

## The 24 bit direct 444 format

Time	0	1	2	3	4	5	6	7
Sample Y - line	Y <sub>0</sub>		Y <sub>1</sub>		Y <sub>2</sub>		Y <sub>3</sub>	
Sample U - line	Cb <sub>0</sub>		Cb <sub>1</sub>		Cb <sub>2</sub>		Cb <sub>3</sub>	
Sample V - line	Cr <sub>0</sub>		Cr <sub>1</sub>		Cr <sub>2</sub>		Cr <sub>3</sub>	
Lum. pixel number	0		1		2		3	
Colour pixel number	0		1		2		3	

## Digital video encoder (DENC2-SQ)

SAA7187

**Bit allocation map**

Slave Receiver [ Slave Address 88h or 8Ch]

REGISTER FUNCTION	SUB- ADDR	DATA BYTE							
		D7	D6	D5	D4	D3	D2	D1	D0
NULL	00	0	0	0	0	0	0	0	0
.....									
NULL	39	0	0	0	0	0	0	0	0
Input_Port_Control	3A	CBENB	0	0	0	VY2C	VUV2C	FMT1	FMT0
OSD_LUT_Y0	42	OSDY07	OSDY06	OSDY05	OSDY04	OSDY03	OSDY02	OSDY01	OSDY00
OSD_LUT_U0	43	OSDU07	OSDU06	OSDU05	OSDU04	OSDU03	OSDU02	OSDU01	OSDU00
OSD_LUT_V0	44	OSDV07	OSDV06	OSDV05	OSDV04	OSDV03	OSDV02	OSDV01	OSDV00
.....									
OSD_LUT_Y7	57	OSDY77	OSDY76	OSDY75	OSDY74	OSDY73	OSDY72	OSDY71	OSDY70
OSD_LUT_U7	58	OSDU77	OSDU76	OSDU75	OSDU74	OSDU73	OSDU72	OSDU71	OSDU70
OSD_LUT_V7	59	OSDV77	OSDV76	OSDV75	OSDV74	OSDV73	OSDV72	OSDV71	OSDV70
Chroma_Phase	5A	CHPS7	CHPS6	CHPS5	CHPS4	CHPS3	CHPS2	CHPS1	CHPS0
Gain_U	5B	GAINU7	GAINU6	GAINU5	GAINU4	GAINU3	GAINU2	GAINU1	GAINU0
Gain_V	5C	GAINV7	GAINV6	GAINV5	GAINV4	GAINV3	GAINV2	GAINV1	GAINV0
Gain_U_MSB, Black_Lev	5D	GAINU8	0	BLCKL5	BLCKL4	BLCKL3	BLCKL2	BLCKL1	BLCKL0
Gain_V_MSB, Blank_Lev	5E	GAINV8	0	BLNNL5	BLNNL4	BLNNL3	BLNNL2	BLNNL1	BLNNL0
NULL	5F	0	0	0	0	0	0	0	0
X-Col_Select	60	CCRS1	CCRS0	0	0	0	0	0	0
Standard_Control	61	0	DOWN	INPI1	YGS	RTCE	SCBW	PAL	FISE
Burst_Amplitude	62	SQP	BSTA6	BSTA5	BSTA4	BSTA3	BSTA2	BSTA1	BSTA0
Subcarrier_0	63	FSC07	FSC06	FSC05	FSC04	FSC03	FSC02	FSC01	FSC00
Subcarrier_1	64	FSC15	FSC14	FSC13	FSC12	FSC11	FSC10	FSC09	FSC08
Subcarrier_2	65	FSC23	FSC22	FSC21	FSC20	FSC19	FSC18	FSC17	FSC16
Subcarrier_3	66	FSC31	FSC30	FSC29	FSC28	FSC27	FSC26	FSC25	FSC24
Line21_Odd_0	67	L21O07	L21O06	L21O05	L21O04	L21O03	L21O02	L21O01	L21O00
Line21_Odd_1	68	L21O17	L21O16	L21O15	L21O14	L21O13	L21O12	L21O11	L21O10
Line21_Even_0	69	L21E07	L21E06	L21E05	L21E04	L21E03	L21E02	L21E01	L21E00
Line21_Even_1	6A	L21E17	L21E16	L21E15	L21E14	L21E13	L21E12	L21E11	L21E10
CC_Line	6B	0	0	0	SCCLN4	SCCLN3	SCCLN2	SCCLN1	SCCLN0
RCV_Port_Control	6C	SRCV11	SRCV10	TRCV2	ORCV1	PRCV1	CBLF	ORCV2	PRCV2
RCM, CC-Mode	6D	0	0	0	0	SRCM11	SRCM10	CCEN1	CCEN0
H-Trigger	6E	HTRIG7	HTRIG6	HTRIG5	HTRIG4	HTRIG3	HTRIG2	HTRIG1	HTRIG0
H-Trigger	6F	0	0	0	0	0	HTRIG10	HTRIG09	HTRIG08



## Digital video encoder (DENC2-SQ)

SAA7187

## Slave Receiver [ Slave Address 88h or 8Ch]

REGISTER FUNCTION	SUB-ADDR	DATA BYTE							
		D7	D6	D5	D4	D3	D2	D1	D0
Fsc_Res_Mode, V-Trigger	70	PHRES1	PHRES0	SBLBN	VTRIG4	VTRIG3	VTRIG2	VTRIG1	VTRIG0
Beg_Master_Request	71	BMRQ7	BMRQ6	BMRQ5	BMRQ4	BMRQ3	BMRQ2	BMRQ1	BMRQ0
End_Master_Request	72	EMRQ7	EMRQ6	EMRQ5	EMRQ4	EMRQ3	EMRQ2	EMRQ1	EMRQ0
MSBs_Mast_Request	73	0	EMRQ10	EMRQ9	EMRQ8	0	BMRQ10	BMRQ9	BMRQ8
NULL	74	0	0	0	0	0	0	0	0
NULL	75	0	0	0	0	0	0	0	0
NULL	76	0	0	0	0	0	0	0	0
Begin_RCV2_out	77	BRCV7	BRCV6	BRCV5	BRCV4	BRCV3	BRCV2	BRCV1	BRCV0
End_RCV2_out	78	ERCv7	ERCv6	ERCv5	ERCv4	ERCv3	ERCv2	ERCv1	ERCv0
MSBs_RCV2_out	79	0	ERCv10	ERCv09	ERCv08	0	BRCV10	BRCV09	BRCV08
Field_Length	7A	FLEN7	FLEN6	FLEN5	FLEN4	FLEN3	FLEN2	FLEN1	FLEN0
First_Act_Line	7B	FAL7	FAL6	FAL5	FAL4	FAL3	FAL2	FAL1	FAL0
Last_Act_Line	7C	LAL7	LAL6	LAL5	LAL4	LAL3	LAL2	LAL1	LAL0
MSBs_Field_Ctrl	7D	0	0	LAL8	FAL8	0	0	FLEN9	FLEN8

I<sup>2</sup>C-Bus Format

S	Slave Address	A	Subaddress	A	DATA0	A	-----	DATA <sub>n</sub>	A	P
---	---------------	---	------------	---	-------	---	-------	-------------------	---	---

Portion	Meaning
S	start condition
Slave Address	1000100X or 1000110X
A	acknowledge, generated by the slave
Subaddress(*)	subaddress byte
DATA	data byte
-----	continued data bytes and A's
P	stop condition
	X: read/write control bit; X=0 is order to write; X=1 is order to read, no subaddressing with read.

(\*) if more than 1 byte DATA is transmitted, then auto-increment of the subaddress is performed.

## Digital video encoder (DENC2-SQ)

SAA7187

## Slave Receiver

## Subaddress 3A:

FMT	Select input data format		
	FMT1	FMT0	function
	0	0	input data YUV 444, 24 lines, Y on VP1, Cr on VP2, Cb on VP3 (default after reset)
	0	1	input data YUV 422, 16 lines, Y on VP1, multiplexed CbCr on VP3
	1	0	input data YUV 422, 8 lines, multiplexed acc. to CCIR-656 on VP1
	1	1	input data YUV 422, 8 lines, multiplexed acc. to CCIR-656 on VP1
VUV2C	0	Cb/Cr data input to VP ports are two's complement (default after reset)	
	1	Cb/Cr data input to VP ports are straight binary	
VY2C	0	Y data input to VP1 port are two's complement (default after reset)	
	1	Y data input to VP1 port are straight binary	
CBENB	0	Data from input ports are encoded (default after reset)	
	1	Colour Bar with programmable colours (entries of OSD-LUTs) is encoded The LUTs are read in upward order from index 0 to index 7.	

## Subaddress 42 .. 59:

OSDY OSDU OSDV	Contents of OSD Look-up tables. All 8 entries are 8 bits. Data representation is acc. to CCIR 601 [Y,Cb,Cr], but two's complement, e.g. for a 100/100 [upper number] or 100/75 [lower number] Colour Bar:				
	Colour	OSDY	OSDU	OSDV	index (for normal colour bar with CBENB = 1)
White		107 (6Bh)	0 (00h)	0 (00h)	0
		107 (6Bh)	0 (00h)	0 (00h)	
Yellow		82 (52h)	144 (90h)	18 (12h)	1
		34 (22h)	172 (ACh)	14 (0Eh)	
Cyan		42 (2Ah)	38 (26h)	144 (90h)	2
		03 (03h)	29 (1Dh)	172 (ACh)	
Green		17 (11h)	182 (B6h)	162 (A2h)	3
		240 (F0h)	200 (C8h)	185 (B9h)	
Magenta		234 (EAh)	74 (4Ah)	94 (5Eh)	4
		212 (D4h)	56 (38h)	71 (47h)	
Red		209 (D1h)	218 (DAh)	112 (70h)	5
		193 (C1h)	227 (E3h)	84 (54h)	
Blue		169 (A9h)	112 (70h)	238 (EEh)	6
		163 (A3h)	84 (54h)	242 (F2h)	
Black		144 (90h)	0 (00h)	0 (00h)	7
		144 (90h)	0 (00h)	0 (00h)	

## Subaddress 5A:

CHPS	Phase of encoded colour subcarrier (including burst) relative to H - sync. Can be adjusted in steps of 360/256 degrees.
------	---

## Digital video encoder (DENC2-SQ)

SAA7187

**Subaddress 5B, 5D:**

GAINU	<p>Variable gain for Cb signal (Input Representation acc. to CCIR 601) White - Black = 92.5 IRE</p> <p>White - Black = 92.5 IRE</p> <p>GAINU=0            Output subcarrier of U contribution = 0</p> <p>GAINU=118 (76h)   Output subcarrier of U contribution = nominal</p> <p>GAINU = -2.17 * nominal ... nominal ... 2.16 * nominal</p> <p>White - Black = 100 IRE</p> <p>GAINU= 0            Output subcarrier of U contribution = 0</p> <p>GAINU=125 (7Dh)   Output subcarrier of U contribution = nominal</p> <p>GAINU = -2.05 * nominal ... nominal ... 2.04 * nominal</p>
-------	---

**Subaddress 5C, 5E:**

GAINV	<p>Variable gain for Cr signal (Input Representation acc. to CCIR 601)</p> <p>White - Black = 92.5 IRE</p> <p>GAINV= 0            Output subcarrier of V contribution = 0</p> <p>GAINV=165 (A5h)   Output subcarrier of V contribution = nominal</p> <p>GAINV = -1.55 * nominal ... nominal ... 1.55 * nominal</p> <p>White-Black = 100 IRE</p> <p>GAINV= 0            Output subcarrier of V contribution = 0</p> <p>GAINV=175 (AFh)   Output subcarrier of V contribution = nominal</p> <p>GAINV = -1.46 * nominal ... nominal ... 1.46 * nominal</p>
-------	---

**Subaddress 5D:**

BLCKL	<p>Variable Black Level (Input Representation acc. to CCIR 601)</p> <p>White - Sync = 140 IRE</p> <p>BLCKL= 0            Output Black Level = 24 IRE</p> <p>BLCKL= 63 (3Fh)   Output Black Level = 49 IRE</p> <p>Output Black Level/IRE = BLCKL * 25/63 + 24</p> <p>Recommended Value:   BLCKL = 60 (3Ch) (normal)</p> <p>White-Sync = 143 IRE</p> <p>BLCKL= 0            Output Black Level = 24 IRE</p> <p>BLCKL= 63 (3Fh)   Output Black Level = 50 IRE</p> <p>Output Black Level/IRE = BLCKL * 26/63 + 24</p> <p>Recommended Value:   BLCKL = 45 (2Dh) (normal)</p>
-------	--

## Digital video encoder (DENC2-SQ)

SAA7187

**Subaddress 5E:**

BLNNL	Variable Blanking Level
	White - Sync = 140 IRE BLNNL= 0           Output Blanking Level = 17 IRE BLNNL= 63 (3Fh) Output Blanking Level = 42 IRE Output Blanking Level/IRE = BLNNL * 25/63 + 17 Recommended Value: BLNNL = 58 (3Ah) (normal)
	White - Sync = 143 IRE
	BLNNL= 0           Output Blanking Level = 17 IRE BLNNL= 63 (3Fh) Output Blanking Level = 43 IRE Output Blanking Level/IRE = BLNNL * 26/63 + 17 Recommended Value: BLNNL = 63 (3Fh) (normal)

**Subaddress 60:**

CCRS	Select cross colour reduction filter in luminance		
	CCRS1	CCRS0	function
	0	0	No Cross Colour Reduction (for transfer characteristic of luminance see figs. 5, 9)
	0	1	Cross Colour Reduction #1 active (for transfer characteristic see figs. 5, 9)
	1	0	Cross Colour Reduction #2 active (for transfer characteristic see figs. 5, 9)
	1	1	Cross Colour Reduction #3 active (for transfer characteristic see figs. 5, 9)

**Subaddress 61:**

FISE	0	944 total pixel clocks per line
	1	780 total pixel clocks per line (default after reset)
PAL	0	NTSC Encoding (non-alternating V-component) (default after reset)
	1	PAL Encoding (alternating V-component)
SCBW	0	Enlarged Bandwidth for Chrominance Encoding (for overall transfer characteristic of chrominance in base-band representation see figs. 3 and 4, 7 and 8).
	1	Standard Bandwidth for Chrominance Encoding (for overall transfer characteristic of chrominance in base-band representation see figs. 3 and 4, 7 and 8). (default after reset)
RTCE	0	No Real Time Control of generated Subcarrier Frequency (default after reset)
	1	Real Time Control of generated Subcarrier Frequency through SAA7191B (timing see fig. 13)
YGS	0	Luminance Gain for White-Black 100 IRE
	1	Luminance Gain for White-Black 92.5 IRE incl. 7.5 IRE Set-up of Black (default after reset)
INPI	0	PAL Switch phase is nominal (default after reset)
	1	PAL Switch phase is inverted compared to nominal
DOWN	0	DACs in normal operational mode (default after reset)
	1	DACs forced to lowest output voltage

## Digital video encoder (DENC2-SQ)

SAA7187

**Subaddress 62:**

BSTA	<p>Amplitude of Colour Burst (Input Representation acc. to CCIR 601)</p> <p>White-Black = 92.5 IRE, Burst = 40 IRE, NTSC-Encoding  BSTA = 0 .. 1.25 * nominal  Recommended Value: BSTA = 102(66h)</p> <p>White-Black = 92.5 IRE, Burst = 40 IRE, PAL-Encoding  BSTA = 0 .. 1.76 * nominal  Recommended Value: BSTA = 72(48h)</p> <p>White-Black = 100 IRE, Burst = 43 IRE, NTSC-Encoding  BSTA = 0 .. 1.20 * nominal  Recommended Value: BSTA = 106(6Ah)</p> <p>White-Black = 100 IRE, Burst = 43 IRE, PAL-Encoding  BSTA = 0 .. 1.67 * nominal  Recommended Value: BSTA = 75(4Bh)</p>
SQP	<p>0 not supported in current version, do not use</p> <p>1 Subcarrier Real Time Control from 7191B Digital Colour Decoder</p>

Note to subaddresses 5B,5C,5D,5E,62: All IRE values are rounded

**Subaddress 63 .. 66 :**

FSC0	Four bytes to program subcarrier frequency	
...		$F(f_{sc})$ Subcarrier frequency (in multiples of line frequency)
FSC3	$FSC = \text{round}\left(\frac{F(f_{sc})}{F(f_{lc})} \times 2^{32}\right)$	$F(f_{lc})$ Clock frequency (in multiples of line frequency)
		FSC3 Most significant byte
		FSC0 Least significant byte
	Examples:	
	NTSC-M: $F(f_{sc}) = 227.5$ , $F(f_{lc}) = 1560 \implies$	FSC = 626349397 (25555555h)
	PAL-B/G: $F(f_{sc}) = 283.7516$ , $F(f_{lc}) = 1888 \implies$	FSC = 645499916 (26798C0Ch)

**Subaddress 67 .. 6A:**

L21O0	First Byte of Captioning Data, Odd Field
L21O1	Second Byte of Captioning Data, Odd Field
L21E0	First Byte of Extended Data, Even Field
L21E1	Second Byte of Extended Data, Even Field
	LSBs of the respective bytes are encoded immediately after run-in and framing code, the MSBs of the respective bytes have to carry the parity bit, acc. to the definition of line 21 encoding format.

**Subaddress 6B**

SCCLN	<p>Selects the actual line, where Closed Caption or Extended Data are encoded.</p> <p>Line = (SCCLN + 4) for M-systems</p> <p>Line = (SCCLN + 1) for other systems</p>
-------	--

## Digital video encoder (DENC2-SQ)

SAA7187

## Subaddress 6C:

PRCV2	0	Polarity of RCV2 as output is high-active, rising edge is taken when input, respectively (default after reset).			
	1	Polarity of RCV2 as output is low-active, falling edge is taken when input, respectively			
ORCV2	0	Pin RCV2 is switched to input (default after reset).			
	1	Pin RCV2 is switched to output			
CBLF	0	If ORCV2=high, pin RCV2 provides a HREF signal (Horizontal Reference Pulse that is high during active portion of line, also during Vertical Blanking Interval). (default after reset) If ORCV2=low, signal input to RCV2 is used for horizontal synchronization only (if TRCV2 = 1). (default after reset)			
	1	If ORCV2=high, pin RCV2 provides a CBN signal (Reference Pulse that is high during active video, excluding Vertical Blanking Interval). If ORCV2=low, signal input to RCV2 is used for horizontal synchronization (if TRCV2 = 1) as well as an internal blanking signal			
PRCV1	0	Polarity of RCV1 as output is high-active, rising edge is taken when input, respectively. (default after reset)			
	1	Polarity of RCV1 as output is low-active, falling edge is taken when input, respectively.			
ORCV1	0	Pin RCV1 is switched to input (default after reset).			
	1	Pin RCV1 is switched to output.			
TRCV2	0	Horizontal synchronization is taken from RCV1 port. (default after reset)			
	1	Horizontal synchronization is taken from RCV2 port.			
SRCV1	Defines signal type on pin RCV1				
		SRCV11	SRCV10	as output	as input
		0	0	VS	VS
		0	1	FS	FS
		1	0	FSEQ	FSEQ
	1	1	n.a.	n.a.	
					Vertical Sync each field (default after reset)
					Frame Sync (_odd/even)
					Field SEquence, Vertical sync every fourth (FISE=1) or eighth field (FISE=0)

## Subaddress 6D:

CCEN	Enables individual Line 21 Encoding			
		CCEN1	CCEN0	
		0	0	Line 21 Encoding OFF
		0	1	Enables Encoding in field 1 (odd)
		1	0	Enables Encoding in field 2 (even)
	1	1	Enables Encoding in both fields	
SRCM	Defines signal type on pin RCM1			
		SRCM1	SRCM0	as output
		0	0	VS
		0	1	FS
		1	0	FESQ
	1	1	n.a.	
				Vertical Sync each field
				Frame Sync (_odd/even)
				Field SEquence, Vertical sync every fourth (FISE=1) or eighth field (FISE=0)

## Digital video encoder (DENC2-SQ)

SAA7187

**Subaddress 6E .. 6F:**

HTRIG	<p>Sets the Horizontal TRIGger phase related to signal on RCV1 or RCV2 input.</p> <p>Values above 1559 (FISE=1) or 1887 [FISE=0] are not allowed.</p> <p>Increasing HTRIG decreases delays of all internally generated timing signals.</p> <p>Reference mark: Analog output horizontal sync (leading slope) coincides with active edge of RCV used for triggering at HTRIG = 031h [033h]</p>
-------	--

**Subaddress 70:**

VTRIG	<p>Sets the Vertical TRIGger phase related to signal on RCV1 input.</p> <p>Increasing VTRIG decreases delays of all internally generated timing signals, measured in half lines</p> <p>Variation range of VTRIG = 0 .. 31(1Fh)</p>															
SBLBN	<p>0 Vertical Blanking is defined by programming of FAL and LAL.</p> <p>1 Vertical Blanking is forced automatically at least during field synchronization and equalization pulses.</p> <p>Note: If Cross-Colour Reduction is programmed, it is active between FAL and LAL in both cases.</p>															
PHRES	<p>Selects the phase reset mode of the colour subcarrier generator</p> <table border="1"> <thead> <tr> <th>PHRES1</th> <th>PHRES0</th> <th></th> </tr> </thead> <tbody> <tr> <td>0</td> <td>0</td> <td>no reset</td> </tr> <tr> <td>0</td> <td>1</td> <td>reset every two lines</td> </tr> <tr> <td>1</td> <td>0</td> <td>reset every eight fields</td> </tr> <tr> <td>1</td> <td>1</td> <td>reset every four fields</td> </tr> </tbody> </table>	PHRES1	PHRES0		0	0	no reset	0	1	reset every two lines	1	0	reset every eight fields	1	1	reset every four fields
PHRES1	PHRES0															
0	0	no reset														
0	1	reset every two lines														
1	0	reset every eight fields														
1	1	reset every four fields														

**Subaddress 71 .. 73:**

BMRQ	<p>Begin of Master ReQuest signal (RCM2).</p> <p>Values above 1559 (FISE=1) or 1887 [FISE=0] are not allowed.</p> <p>First active pixel at analog outputs (corresp. input pixel coinciding with RCM2) at BMRQ=0E1h [130h]</p>
EMRQ	<p>End of Master ReQuest signal (RCM2).</p> <p>Values above 1559 (FISE=1) or 1887 [FISE=0] are not allowed.</p> <p>Last active pixel at analog outputs (corresp. input pixel coinciding with RCM2) at EMRQ=5E9h [72Ah]</p>

## Digital video encoder (DENC2-SQ)

SAA7187

**Subaddress 77 .. 79:**

BRCV	<p>Begin of output signal on RCV2 pin.</p> <p>Values above 1559 (FISE=1) or 1887 [FISE=0] are not allowed.</p> <p>First active pixel at analog outputs (corresp. input pixel coinciding with RCV2) at BRCV=0E1h [130h]</p>
ERCV	<p>End of output signal on RCV2 pin.</p> <p>Values above 1559 (FISE=1) or 1887 [FISE=0] are not allowed.</p> <p>Last active pixel at analog outputs (corresp. input pixel coinciding with RCV2) at ERCV=5E9h [72Ah]</p>

**Subaddress 7A .. 7D:**

FLEN	<p>LENGTH of a Field = FLEN + 1, measured in half lines</p> <p>Valid range is limited to 524 .. 1022 (FISE=1) resp. 624 .. 1022 (FISE=0), FLEN should be even</p>
FAL	<p>First Active Line, measured in lines.</p> <p>FAL=0 coincides with the first field synchronization pulse.</p>
LAL	<p>Last Active Line, measured in lines</p> <p>LAL=0 coincides with the first field synchronization pulse.</p>

**Slave Transmitter****Slave Transmitter [Slave Address 89h or 8Dh]**

REGISTER FUNCTION	SUB- ADDR	DATA BYTE							
		D7	D6	D5	D4	D3	D2	D1	D0
Status Byte	-	VER2	VER1	VER0	CCRDE	CCRDO	FSQ2	FSQ1	FSQ0

**no subaddress**

VER	<p>Version id of the device. It will be changed with all versions of the IC that have different programming models</p> <p>Current Version is 000 bin.</p>
CCRDE	<p>Closed caption bytes of the even field have been encoded.</p> <p>The bit is reset after information has been written to the subaddresses 69, 6A. It is set immediately after the data have been encoded.</p>
CCRDO	<p>Closed caption bytes of the odd field have been encoded.</p> <p>The bit is reset after information has been written to the subaddresses 67, 68. It is set immediately after the data have been encoded.</p>
FSQ	<p>State of the internal field sequence counter.</p> <p>Bit 0 (FSQ0) gives the odd/even information. (Odd=Low, Even=High)</p>



Digital video encoder (DENC2-SQ)

SAA7187

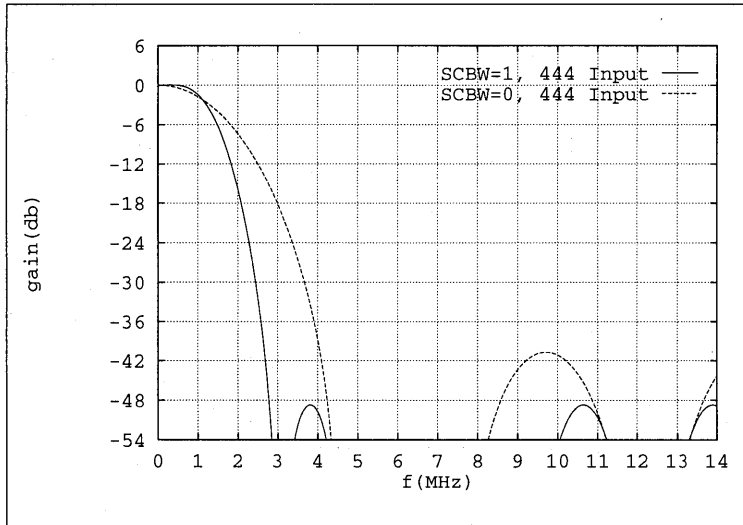

Fig. 3: Chrominance transfer characteristic [60 Hz]

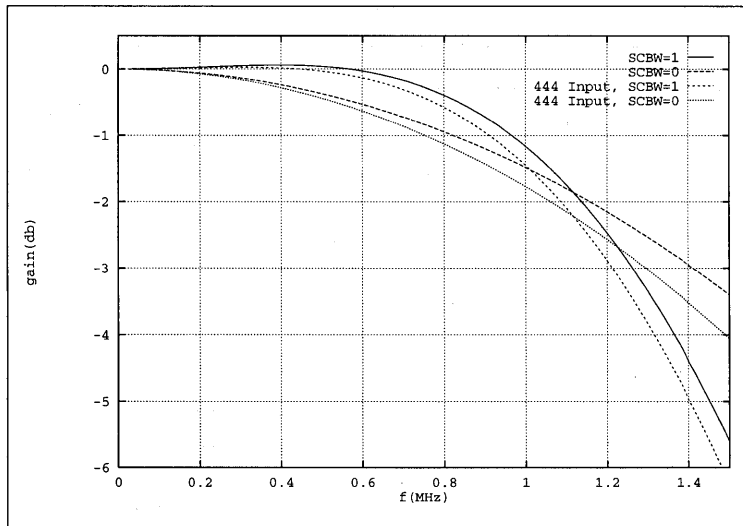

Fig. 4: Chrominance transfer characteristic [60 Hz]

Digital video encoder (DENC2-SQ)

SAA7187

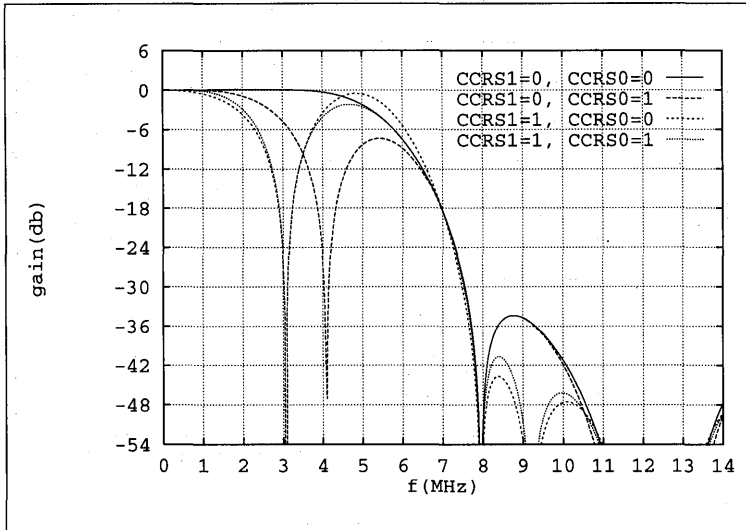

Fig. 5: Luminance transfer characteristic [60 Hz]

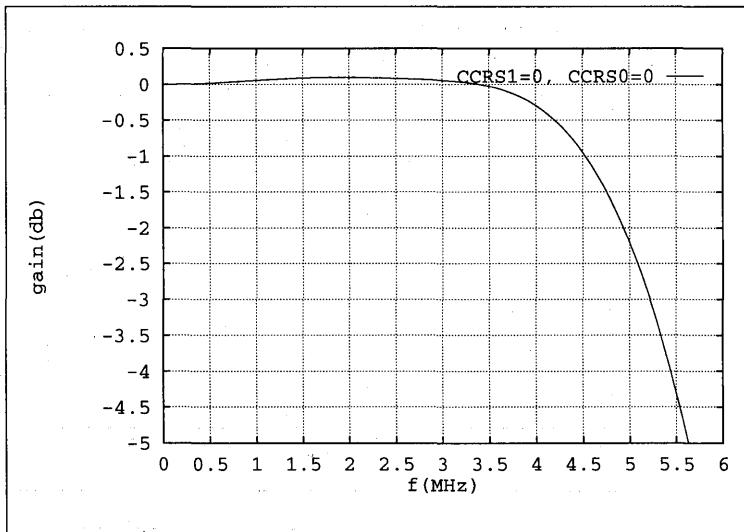

Fig. 6: Luminance transfer characteristic [60 Hz]

Digital video encoder (DENC2-SQ)

SAA7187

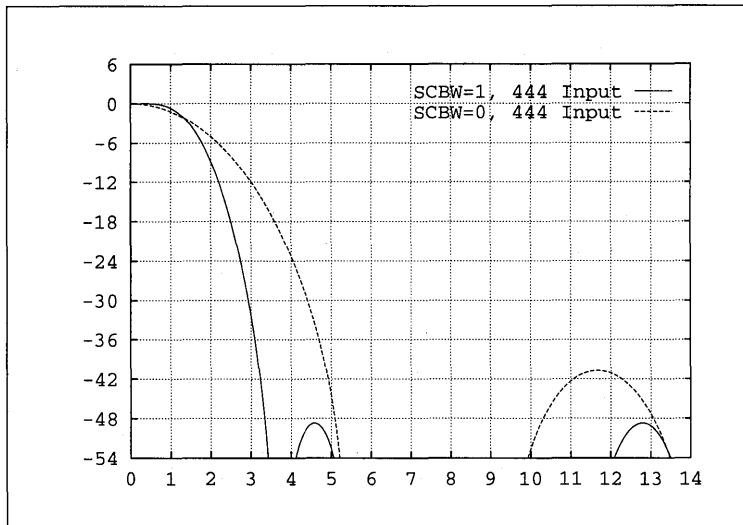

Fig. 7: Chrominance transfer characteristic [50 Hz]

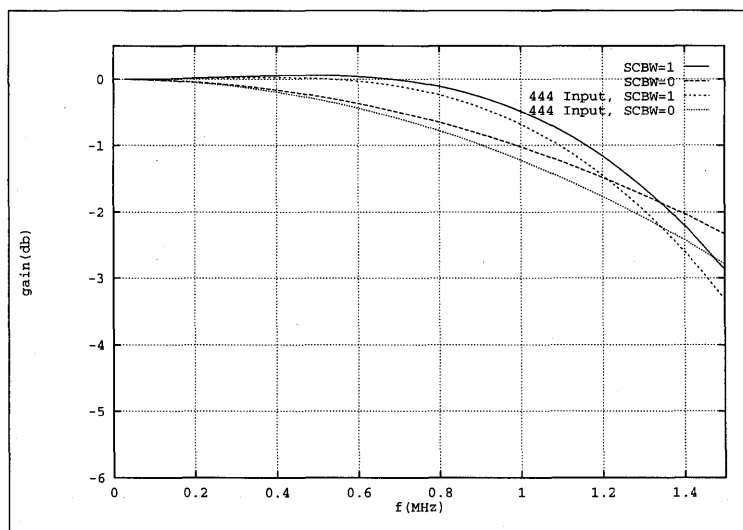

Fig. 8: Chrominance transfer characteristic [50 Hz]

Digital video encoder (DENC2-SQ)

SAA7187

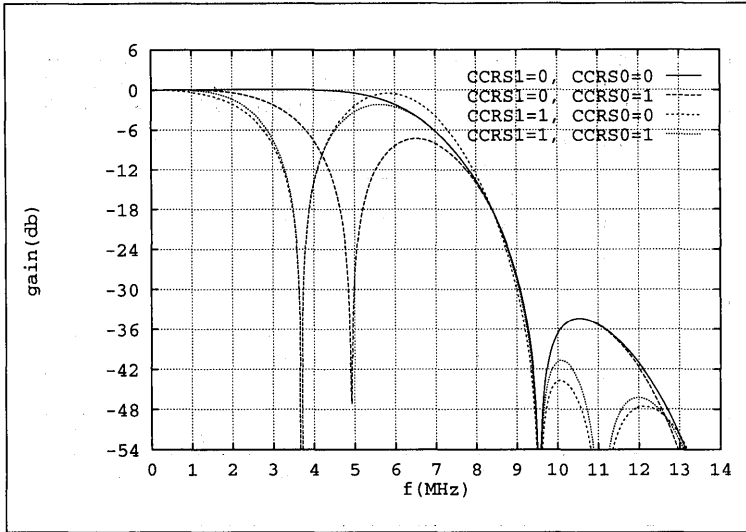

Fig. 9: Luminance transfer characteristic [50 Hz]

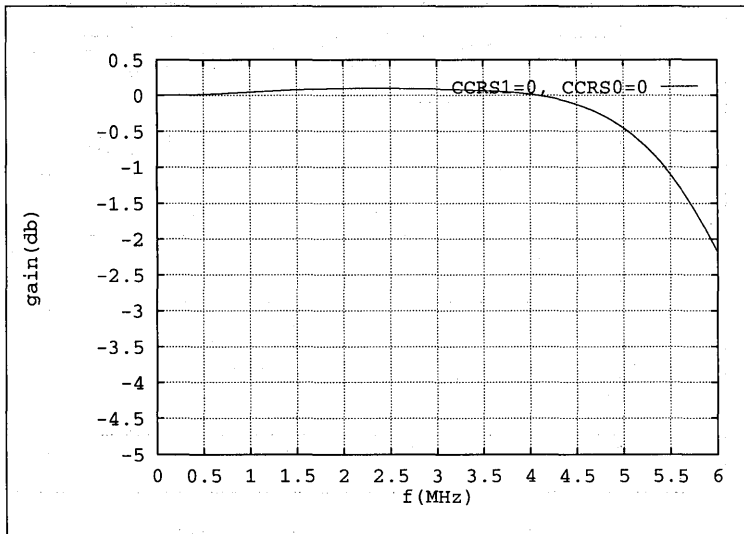

Fig. 10: Luminance transfer characteristic [50 Hz]

## Digital video encoder (DENC2-SQ)

SAA7187

## Electrical Characteristics

Conditions:  $T_{amb} = 0 \dots 70 \text{ }^\circ\text{C}$ ;  $V_{DD} = 4.5 \dots 5.5 \text{ V}$  unless otherwise specified.

SYMBOL	PARAMETER	TEST CONDITIONS	LIMITS		UNIT
			MIN	MAX	
<b>Supply</b>					
$V_{DDD}$	supply voltage range digital		4.5	5.5	V
$V_{DDA}$	supply voltage range analog		4.75	5.25	V
$I_{DDD}$	supply current	1)	-	210	mA
$I_{DDA}$	supply current	1)	-	55	mA
<b>Inputs</b>					
$V_{IL}$	input voltage LOW (except SDA, SCL, AP, SP, XTALI)		-0.5	0.8	V
$V_{IH}$	input voltage HIGH (except SDA, SCL, AP, SP, XTALI)		2.0	$V_{DDD}+0.5$	V
$V_{IH}$	input voltage HIGH (LLC)	pin 38, only	2.4	$V_{DDD}+0.5$	V
$I_{LI}$	input leakage current		-	1	$\mu\text{A}$
$C_I$	input capacitance	clocks	-	10	pF
$C_I$	input capacitance	data		8	pF
$C_I$	input capacitance	I/O at high impedance		8	pF
<b>Outputs</b>					
$V_{OL}$	output voltage LOW (except XTAL, SDA)	2)	0	0.6	V
$V_{OH}$	output voltage HIGH (except XTAL, DTACKN, SDA)	2)	2.4	$V_{DDD}+0.5$	V
$V_{OH}$	output voltage HIGH (LLC)	2) pin 38, only	2.6	$V_{DDD}+0.5$	V
<b>I<sup>2</sup>C Bus SDA and SCL</b>					
$V_{IL}$	input voltage LOW		-0.5	1.5	V
$V_{IH}$	input voltage HIGH		3.0	$V_{DDD}+0.5$	V
$I_I$	input current	$V_I = \text{low or high}$		+/-10	$\mu\text{A}$
$V_{OL}$	SDA output voltage	$I_O = 3 \text{ mA}$		0.4	V
$I_O$	output current	during acknowl.	3		mA
<b>Clock timing</b>					
$t_{LLC}$	cycle time LLC	3)	31	44	ns
$\delta$	duty factor $t_{LLCh} / t_{LLC}$	10)	40	60	%
$t_r$	rise time LLC	3)	-	5	ns
$t_f$	fall time LLC	3)	-	6	ns
<b>Input timing</b>					
$t_{SUC}$	input data setup time (CREF)		6	-	ns
$t_{HDC}$	input data hold time (CREF)		3	-	ns
$t_{SU}$	input data setup time (any other except SEL_MPU, CDIR, RWN/SCL, A0/SDA, CSN/SA, RESN, AP, SP)		6	-	ns

## Digital video encoder (DENC2-SQ)

SAA7187

SYMBOL	PARAMETER	TEST CONDITIONS	LIMITS		UNIT
			MIN	MAX	
$t_{HD}$	input data hold time (any other except SEL_MPU, CDIR, RWN/SCL, A0/SDA, CSN/SA, RESN, AP, SP)		3	-	ns
<b>Crystal Oscillator</b>					
$f_n$	nominal frequency (usually 24.545454 MHz or 29.5 MHz)	3rd harmonic	-	30	MHz
$Df/f_n$	permissible deviation $f_n$	9)	-50	+50	$10^{-6}$
	crystal specification:				
	temperature range $T_{amb}$		0	70	C
	load capacitance $C_L$		8	-	pF
	series resonance resistance $R_S$			80	$\Omega$
	motional capacitance $C_1$	typically	1.5-20%	1.5+20%	fF
	parallel capacitance $C_0$	typically	3.5-20%	3.5+20%	pF
<b>MPU interface timing</b>					
$t_{AS}$	address setup time	5)	9	-	ns
$t_{AH}$	address hold time		0	-	ns
$t_{RWS}$	read/write setup time	5)	9	-	ns
$t_{RWH}$	read/write hold time		0	-	ns
$t_{DD}$	data valid from CSN (read)	6), 7), 8), n=9	-	440	ns
$t_{DF}$	data bus floating from CSN (read)	6), 7), n=5	-	275	ns
$t_{DS}$	data bus setup time (write)	5)	9	-	ns
$t_{DH}$	data bus hold time (write)	5)	9	-	ns
$t_{ACS}$	acknowledge delay from CSN	6), 7), n=11	-	520	ns
$t_{CSD}$	CSN high from acknowledge		0	-	ns
$t_{DAT}$	DTACKN floating from CSN high	6), 7), n=7	-	360	ns
<b>Data and reference signal output timing</b>					
$C_L$	output load capacitance		7.5	40	pF
$t_{OH}$	output hold time		4	-	ns
$t_{OD}$	output delay time (CREF in output mode)		-	25	ns
<b>C, Y, and CVBS outputs</b>					
$V_o$	output signal (peak to peak value)	4)	1.9	2.1	V
$R_I$	internal serial resistance		18	35	$\Omega$
$R_L$	output load resistance		80	-	$\Omega$
B	output signal bandwidth (D/A-converters)	-3dB	10	-	MHz
ILE	LF integral linearity error (D/A-converters)		-	$\pm 2$	LSB
DLE	LF differential linearity error (D/A-converters)		-	$\pm 1$	LSB

## Notes:

- 1) at maximum supply voltages and with high-activity input signals
- 2) The levels have to be measured with load circuits of 1.2 k $\Omega$  to 3.0 V (standard TTL load),  $C_L = 25$ pF.

# Digital video encoder (DENC2-SQ)

SAA7187

- 3) The data is for both, input and output direction.
- 4) for full digital range, without load,  $V_{DDA} = 5.0$  V. The typical voltage swing is 2.0 V, the typical minimum output voltage (digital zero at DAC) is 0.2 V.
- 5) The value is calculated via equation (1)
- 6) The value depends on the clock frequency. The numbers given are calculated with  $f_{LLC} = 24.54$  MHz
- 7) The values are calculated via equation (2)
- 8) The falling edge of DTACKN will always occur 1 \* LLC after data is valid.
- 9) If internal oscillator is used, crystal deviation of  $f_n$  is directly proportional to the deviation of subcarrier frequency and line/ field frequency.
- 10) With LLC in input mode. In output mode, with a crystal connected to XTAL/ XTALI typically 50 %.

**Equations:**

(1)  $t = t_{SU} + t_{HD}$

(2)  $t_{dmax} = t_{OD} + n * t_{LLC} + t_{LLC} + t_{SU}$

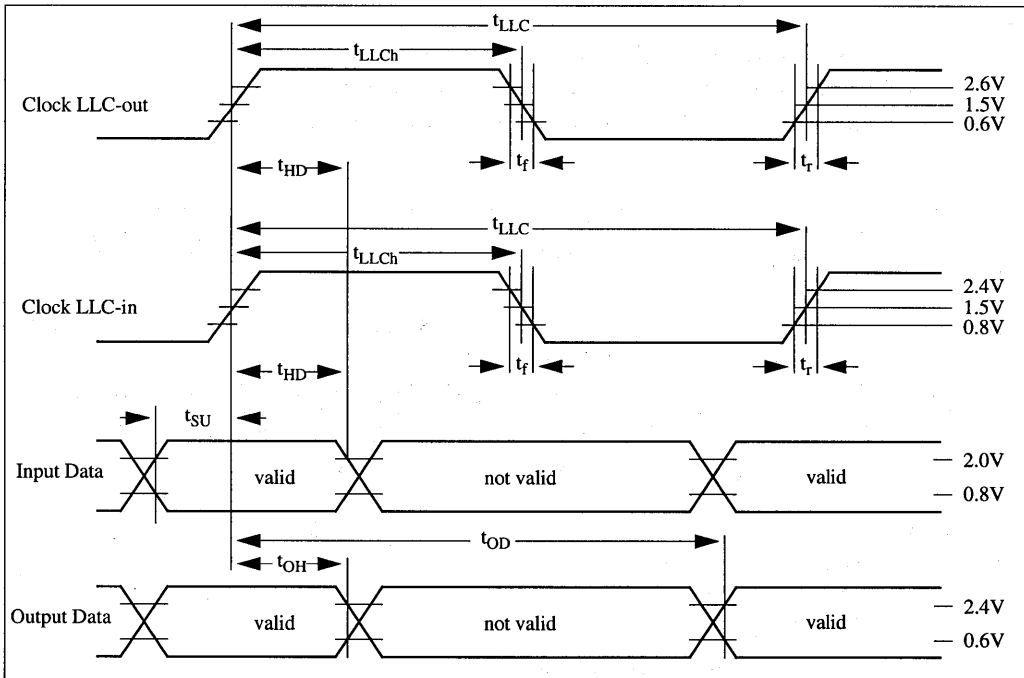

**Fig. 11: Clock Data Timing**

Digital video encoder (DENC2-SQ)

SAA7187

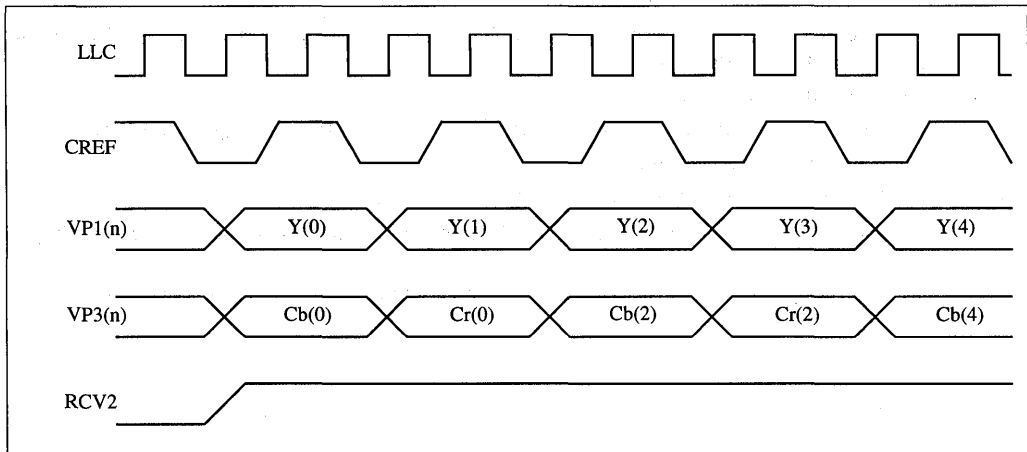

Fig. 12: Dig.TV - Timing

Notes:

- 1) The data demultiplex phase is coupled to the internal horizontal phase.
- 2) The CREF signal applies only for the 16 lines DIG-TV format, because these signals are only valid in 12.27/14.75MHz.
- 3) The phase of the RCV2 signal is programmed to 0E1h [ 130h for 50 Hz ] in this example in output mode (BRCV2)

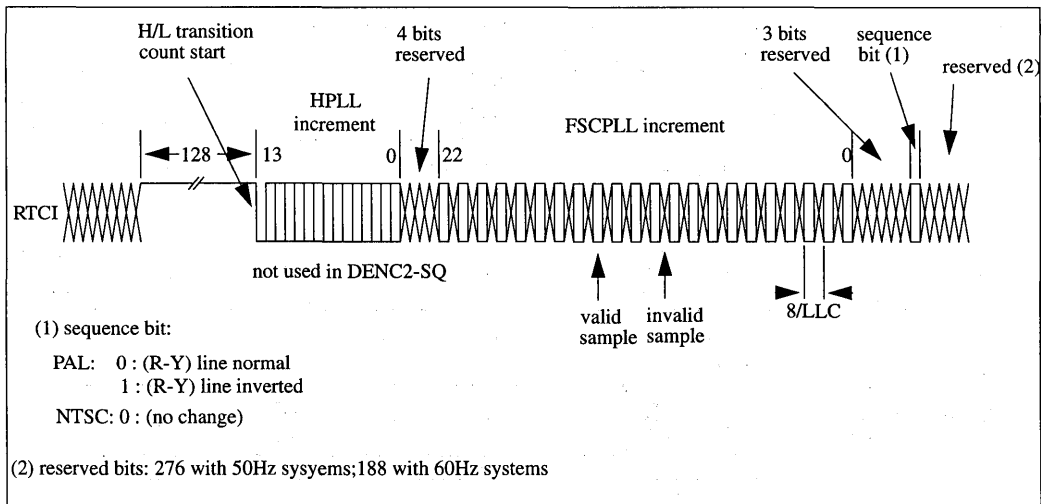

Fig. 13: RTCI timing



Digital video encoder (DENC2-SQ)

SAA7187

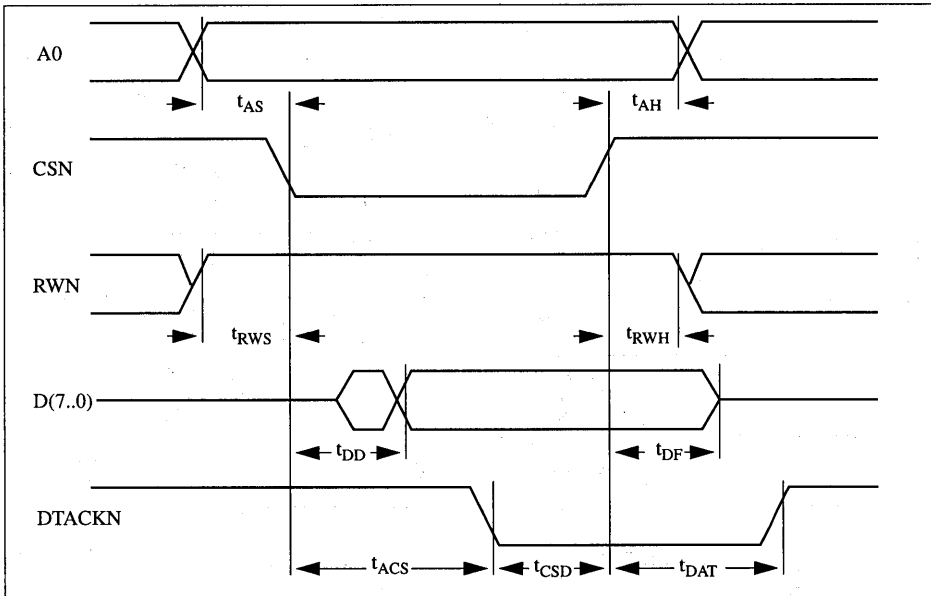

Fig. 14: MPU Interface Timing (Read cycle)

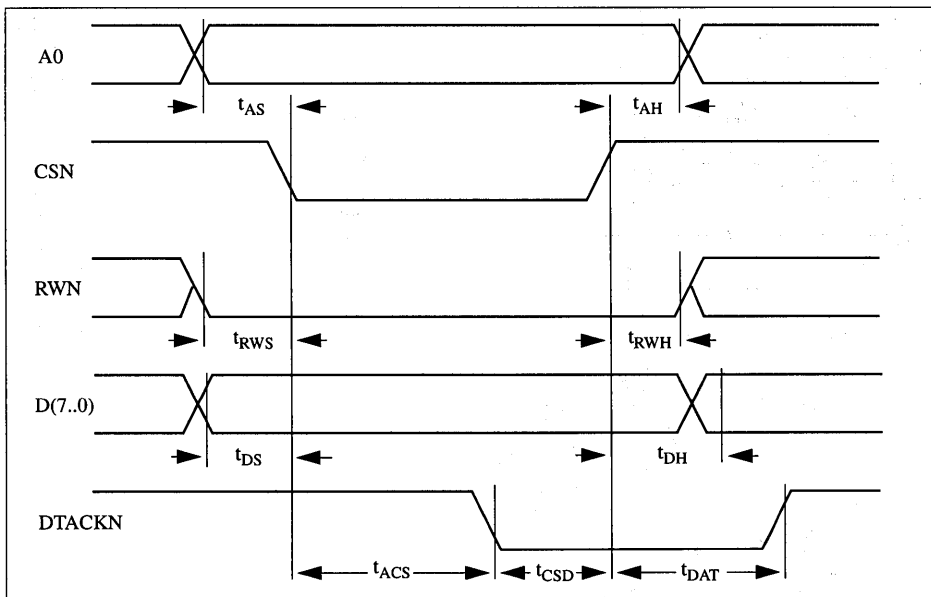
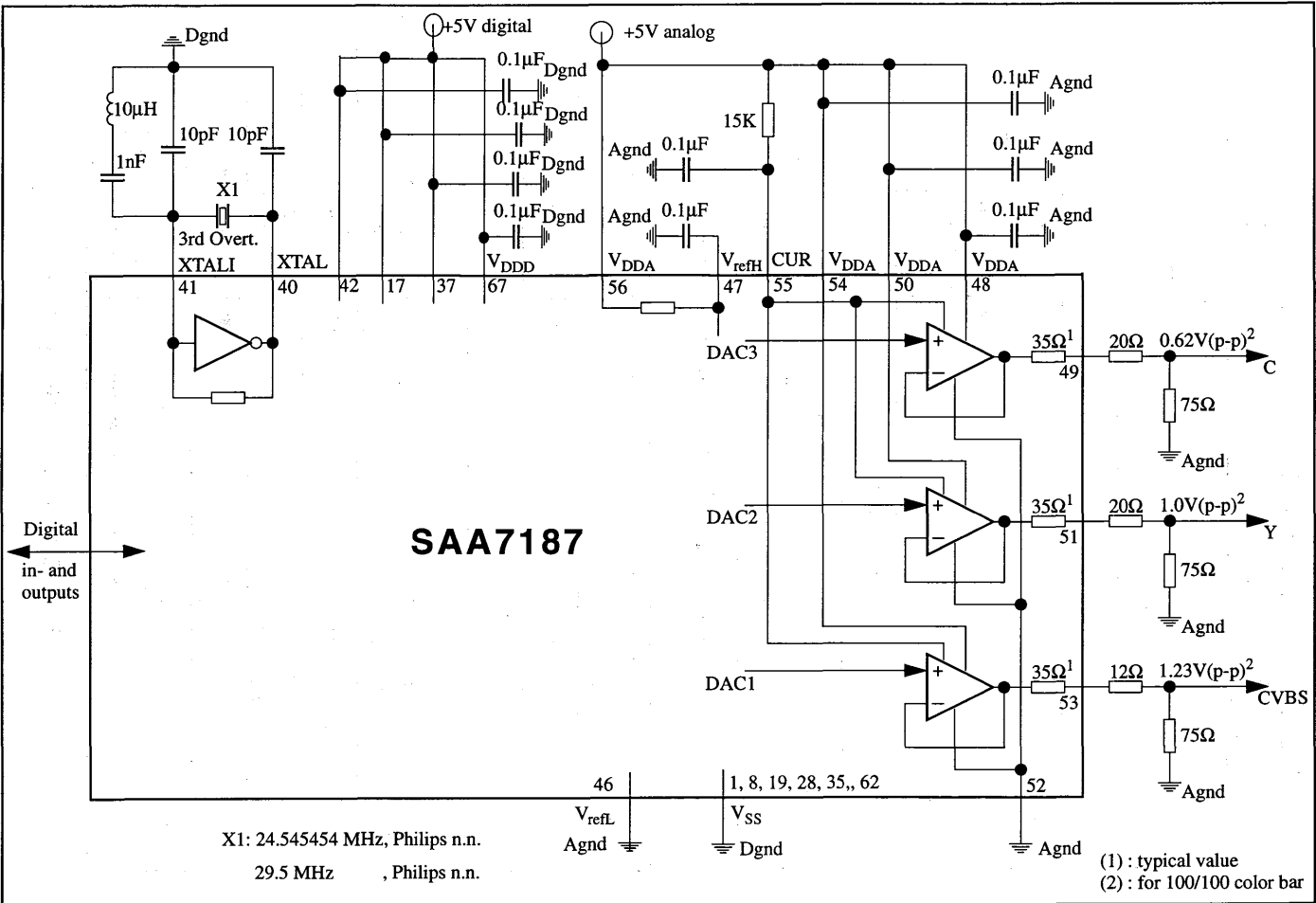

Fig. 15: MPU Interface Timing (Write cycle)

Digital video encoder (DENC2-SQ)

SAA7187



X1: 24.545454 MHz, Philips n.n.  
29.5 MHz, Philips n.n.

Fig.16: Application Environment of the DENC2-SQ

## Digital video encoder (DENC2-M)

SAA7188A

## FEATURES

- Monolithic CMOS 5V device
- Digital PAL/NTSC encoder
- System Pixel Frequency: 13.5 MHz
- Accepts MPEG decoded data.
- 8-bit wide MPEG port.
- Input data format Cb,Y,Cr,Y,... (CCIR 656 like)
- 16-bit wide YUV Input port
- IIC Bus control port or alternatively MPU parallel control port
- Encoder can be master or slave
- Programmable horizontal and vertical input synchronization phase
- Programmable horizontal sync output phase
- OSD overlay with LUTs (8\*3 bytes)
- 'Line 21' Closed Caption encoder
- Macrovision Pay-per-View copy protection system as option (Note 1)
- Cross colour reduction
- DACs running at 27 MHz with 10 bits resolution
- Controlled rise-/fall times of output syncs and blanking
- Down mode of DACs
- CVBS and S-Video output simultaneously.
- PLCC68 package

**Note 1:** This device is protected U.S. patent numbers 4631603, 4577216 and 4819098 and other intellectual property rights. The Macrovision anticopy process is licensed for non-commercial home use only, which is its sole intended use in this device. Please contact your nearest Philips Semiconductors sales office for more information.

## Quick Reference Data

SYMBOL	PARAMETER	MIN.	TYP.	MAX.	UNIT
V <sub>DDD</sub>	digital supply voltage range	4.5	5.0	5.5	V
V <sub>DDA</sub>	analog supply voltage range	4.75	5.0	5.25	V
I <sub>DDD</sub>	supply current digital	-	140	170	mA
I <sub>DDA</sub>	supply current analog	-	50	55	mA
V <sub>i</sub>	input signal levels	TTL - compatible			V
V <sub>o</sub>	analog output signals, Y, C and CVBS without load (peak to peak value)	-	2	-	V
R <sub>L</sub>	load resistance	80	-	-	Ω
ILE	LF integral linearity error	-	-	± 2	LSB
DLE	LF differential linearity error	-	-	± 1	LSB
T <sub>amb</sub>	operating ambient temperature range	0	-	70	°C

## General Description

The Digital Video Encoder 2 (DENC2-M) encodes digital YUV video data to an NTSC or PAL CVBS or S-Video signal.

The circuit accepts CCIR compatible YUV data with 720 active pixels per line in 4:2:2 multiplexed formats, e.g. MPEG decoded data. It includes a sync/

clock generator as well as on chip D/A converters.

The circuit is compatible to the DIG. TV2 chip family.

EXTENDED TYPE NUMBER	PACKAGE			
	PINS	PIN POSITION	MATERIAL	CODE
SAA7188A	68	PLCC	plastic	SOT188

Digital video encoder (DENC2-M)

SAA7188A

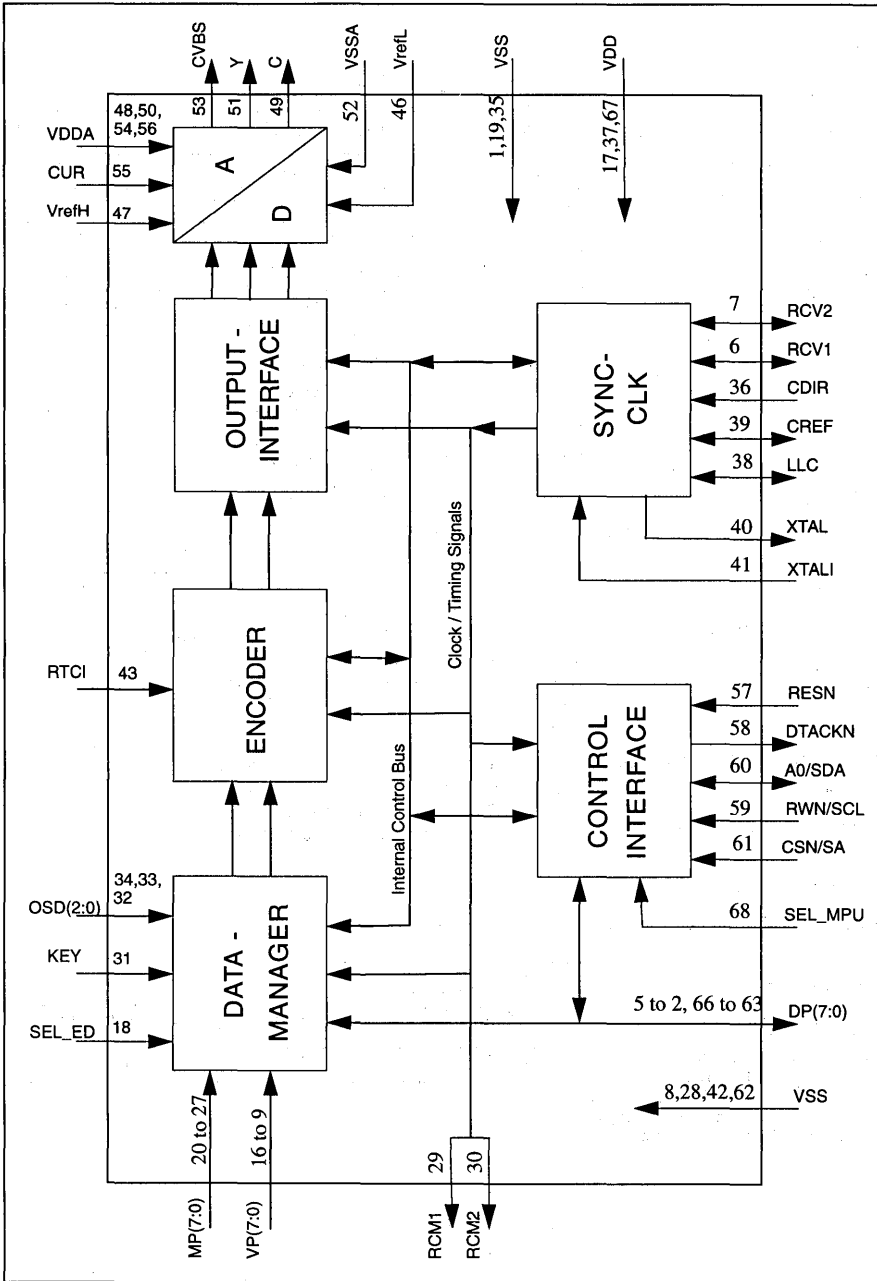

Fig. 1 : Block Diagram

## Digital video encoder (DENC2-M)

SAA7188A

## PINNING

SYMBOL	PIN	DESCRIPTION
VSS	1	Digital negative supply voltage (Ground)
DP(4)	2	Upper 4 bits of the Data Port. If Pin 68 (SEL_MPU) is high, this is the data bus of the parallel MPU interface. If it is low, they are the UV lines of the Video Port
DP(5)	3	
DP(6)	4	
DP(7)	5	
RCV1	6	Raster Control 1 for Video port . Depending on the synchronization mode, this pin receives/provides a VS/FS/FSEQ signal.
RCV2	7	Raster Control 2 for Video port . Depending on the synchronization mode, this pin receives/provides a HS/HREF/CBL signal
VSS	8	Digital negative supply voltage (Ground)
VP(0)	9	Video Port. This is an input for CCIR-656 compatible, multiplexed video data. If the 16-bit DIG-TV2 format is used, this is the Y-data.
VP(1)	10	
VP(2)	11	
VP(3)	12	
VP(4)	13	
VP(5)	14	
VP(6)	15	
VP(7)	16	
VDD	17	Digital positive supply voltage.
SEL_ED	18	Select Encoder Data. Selects data either from MPEG port or from video port as Encoder input.
VSS	19	Digital negative supply voltage (Ground)
MP(7)	20	MPEG Port. It is an input for CCIR-656 style multiplexed YUV data.
MP(6)	21	
MP(5)	22	
MP(4)	23	
MP(3)	24	
MP(2)	25	
MP(1)	26	
MP(0)	27	
VSS	28	Digital negative supply voltage (Ground)
RCM1	29	Raster control 1 for MPEG port . This pin provides a VS/FS/FSEQ signal.
RCM2	30	Raster control 2 for MPEG port . The pin provides a HS pulse for the MPEG decoder.
KEY	31	Key signal for OSD. It is high-active.
OSD(0)	32	On Screen Display data. This is the index for the internal OSD lookup table.
OSD(1)	33	
OSD(2)	34	
VSS	35	Digital negative supply voltage (Ground)
CDIR	36	Clock direction. If the CDIR input is high, the circuit receives a clock signal, otherwise LLC and CREF are generated by the internal crystal oscillator.
VDD	37	Digital positive supply voltage.

## Digital video encoder (DENC2-M)

SAA7188A

## PINNING

SYMBOL	PIN	DESCRIPTION
LLC	38	Line Locked clock. This is the 27 MHz master clock for the encoder. The direction is set by the CDIR pin.
CREF	39	Clock Reference signal. This is the clock qualifier for DIG-TV2 compatible signals.
XTAL	40	Crystal oscillator output (to crystal).
XTALI	41	Crystal oscillator input (from crystal). If the oscillator is not used, this pin should be connected to ground.
VSS	42	Digital negative supply voltage (Ground)
RTCI	43	Real Time Control Input. If the clock is provided by a SAA7151B, RTCI should be connected to the RTCO pin of the decoder to improve the signal quality.
AP	44	Test pin. Connect to digital ground for normal operation.
SP	45	Test pin. Connect to digital ground for normal operation.
VREFL	46	Lower reference voltage for the D/A converters.
VREFH	47	Upper reference voltage for the D/A converters.
VDDA	48	Analog positive supply voltage for the D/A converters and output amplifiers.
C	49	Analog output of the chrominance signal.
VDDA	50	Analog positive supply voltage for the D/A converters and output amplifiers.
Y	51	Analog output of the luminance signal.
VSSA	52	Analog negative supply voltage for the D/A converters and output amplifiers (Ground).
CVBS	53	Analog output of the CVBS signal.
VDDA	54	Analog positive supply voltage for the D/A converters and output amplifiers.
CUR	55	Current input for the output amplifiers, connect via 15k $\Omega$ to VDDA.
VDDA	56	Analog positive supply voltage for the D/A converters and output amplifiers.
RESN	57	Reset input, low active. After reset is applied, all outputs are in tristate/input mode. The IIC receiver waits for the start condition.
DTACKN	58	Data acknowledge output of the parallel MPU interface; low-active, otherwise high-impedance.
RWN/SCL	59	If pin 68 (SEL_MPU) is high, this is the read/write signal of the parallel MPU interface, otherwise it is the IIC serial clock line.
AO/SDA	60	If pin 68 (SEL_MPU) is high, this is the address signal of the parallel MPU interface, otherwise it is the IIC serial data line.
CSN/SA	61	If pin 68 (SEL_MPU) is high, this is the chip select signal of the parallel MPU interface, otherwise it is the IIC slave address select pin: Low : Slave address = 88h; High : Slave address = 8Ch
VSS	62	Digital negative supply voltage (Ground)
DP(0)	63	Lower 4 bits of the Data Port. If Pin 68 (SEL_MPU) is high, this is the data bus of the parallel MPU interface. If it is low, they are the UV lines of the Video Port
DP(1)	64	
DP(2)	65	
DP(3)	66	
VDD	67	Digital positive supply voltage.
SEL_MPU	68	Select MPU interface. If it is high, the parallel MPU interface is active, otherwise the IIC bus interface will be used.

Digital video encoder (DENC2-M)

SAA7188A

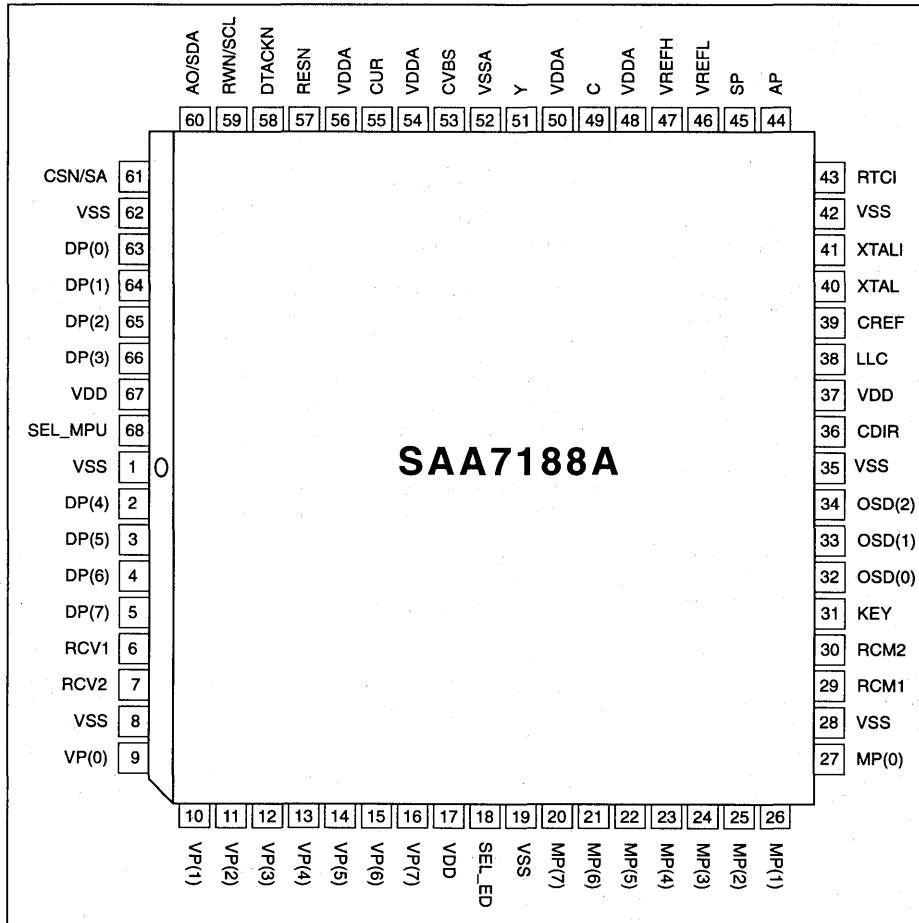

Fig. 2: Pinning Diagram

Functional Description

The digital MPEG-compatible Video Encoder (DENC2-M) encodes digital luminance and chrominance into analog CVBS- and simultaneously S - Video (Y/C) signals. NTSC-M and PAL B/G standards as well as sub-standards are supported.

The basic encoder function consists of subcarrier generation and colour modulation as well as insertion of synchronization signals. Luminance and chrominance signals are filtered according to the standard requirements RS-170-A and CCIR-624.

For ease of analog post filtering the signals are two times oversampled w.r.t. pixel clock before digital-to-analog conversion.

For total filter transfer characteristics see figs 3, 4, 5 and 6. The DACs are realized with full 10 bit resolution. The encoder provides three 8 bit wide data ports, that serve different applications.

The MPEG port (MP) as well as the Video port (VP) accept 8 lines multiplexed Cb-Y-Cr data.

The Video port (VP) is also able to handle DIG-TV2 family compatible 16 bit YUV signals. In this case, the Data port (DP) is used for the U/V components.

The Data port can handle the data of an 8 bit wide microprocessor interface, alternatively.

The 8 bit multiplexed Cb-Y-Cr formats are CCIR-656 (D1 format) compatible, but the SAV, EAV e.t.c. codes are not decoded.

A crystal-stable master clock (LLC) of 27 MHz, which is twice the CCIR line-locked pixel clock of 13.5 MHz, needs to be supplied externally. Optionally, a crystal oscillator input/output pair of pins and an on-chip clock driver is provided. Additionally, a DMSD2 compatible clock interface, using CREF (input or output) and RTC (see data sheet SAA 7151B) is available.

## Digital video encoder (DENC2-M)

SAA7188A

The DENC2-M synthesizes all necessary internal signals, colour subcarrier frequency, as well as synchronization signals, from that clock. DENC2-M is always timing master for the MPEG port (MP), but it can additionally be configured as master or slave for the Video port (VP).

The IC also contains Closed Caption and Extended Data Services Encoding (Line 21), and supports Anti-Taping signal generation acc. to Macrovision; it also supports OSD via KEY and three bit overlay techniques by a 24\*8 LUT.

The IC can be programmed via I2C or 8-bit MPU interface, but only one interface configuration can be active at a time; if the 16 bit Video port mode (VP and DP) is being used, only the I2C interface can be selected.

A lot of possibilities is provided for setting of different video parameters like Black- and Blanking level control, colour subcarrier frequency, variable burst amplitude etc.

During Reset (RESN=low) and after Reset released, all digital I/O stages are set to input mode. A Reset forces the control interfaces to abort any running bus transfer and to set register 3Ah to contents 13h, register 61h to contents 15h, and register 6Ch to contents 00h. All other control registers are not influenced by a Reset.

### Data Manager

In the Data Manager, real time arbitration on the data stream to be encoded is performed.

Depending on hardware conditions (signals on pins SEL\_ED, KEY, OSD(2-0), MP(7-0), VP(7-0), DP(7-0)) and different software programming either data from the MP port, from the VP port, or from the OSD port are selected to be encoded to CVBS and Y/C signals.

Optionally, the OSD colour look-up tables located in this block, can be read out in a pre-defined sequence (8 steps per active video line), achieving e.g. a colour bar test pattern generator without need for an external data source. The colour bar function is under software control, only.

### Encoder

#### Video Path:

The encoder generates out of Y,U,V base band signals output signals luminance and colour subcarrier, suitable for use as CVBS or separate Y and C signals.

Luminance is modified in gain as well as in offset (latter programmable in a certain range to enable different black level set-ups). After having been inserted a fixed sync level, acc. to standard composite sync schemes, and blanking level, programmable also in a certain range to allow for manipulations with Macrovision Anti-Taping, additional insertion of AGC super white pulses, programmable in height, is supported.

In order to enable easy analog post filtering, luminance is interpolated from 13.5 MHz data rate to 27 MHz data rate, providing luminance in 10 bit resolution. This filter is also used to define smoothed transients for sync pulses and blanking period. For transfer characteristic of the luminance interpolation filter see figs. 5 and 6.

Chrominance is modified in gain (programmable separately for U and V), standard dependent burst is inserted, before base band colour signals are interpolated from 6.75 MHz data rate to 27 MHz data rate. One of the interpolation stages can be by-passed, thus providing a higher colour bandwidth, which can be made use of for Y/C output. For transfer characteristics of the chrominance interpolation filter see figs. 3 and 4.

The amplitude of inserted burst is programmable in a certain range, suitable for standard signals as well as for special effects. Behind the succeeding quadrature modulator, colour in 10 bit resolution is provided on subcarrier.

The numeric ratio between Y and C output is acc. to standards.

#### Closed Caption Encoder:

By means of this circuit, data acc. to the specification of Closed Caption or Extended Data Service, delivered by the control interface, can be encoded (LINE21). Two dedicated pairs of bytes (two bytes per field), each pair preceded by run-in clocks and framing code, are possible.

The actual line number where data are to be encoded in, can be modified in a certain range.

Data clock frequency is acc. to definition for NTSC-M standard 32 times horizontal line frequency.

Data LOW at the output of the DACs corresponds to 0 IRE, data HIGH at the output of the DACs corresponds to about 50 IRE.

It is also possible to encode Closed Caption Data for 50 Hz field frequencies at 32 times horizontal line frequency.

#### Anti-Taping:

For more information, please contact your nearest Philips Semiconductors sales office.

### Output Interface

In the output interface encoded Y and C signals are converted from digital to analog in 10 bit resolution both. Y and C signals are combined to a 10 bit CVBS-signal, as well; in front of the summation point, the luminance signal can optionally be fed through a further filter stage, suppressing components in the range of subcarrier frequency. Thus, a kind of Cross Colour reduction is provided, useful in a standard TV set with CVBS input.

Slopes of synchronization pulses are not affected with any Cross Colour reduction active.

Three different filter characteristics or bypass are available, see fig. 5.

The CVBS output occurs with the same processing delay as the Y,C outputs do. Absolute amplitudes at the input of the DAC for CVBS is reduced by 15/16 w.r.t. Y- and C- DACs to make optimized use of conversion ranges.

Outputs of all DACs can be set together via software control to minimum output voltage for either purpose.



## Digital video encoder (DENC2-M)

SAA7188A

### Synchronization

The synchronization of the DENC2-M is able to operate in two modes:

In the slave mode, the circuit accepts sync pulses at the bi-directional RCV1 port. The timing and trigger behaviour related to the video signal on VP (and DP, if used) can be influenced by programming the polarity and on-chip delay of RCV1. Active slope of RCV1 defines the vertical phase and optionally the odd/even- and colour frame phase to be initialized, it can be used also to set the horizontal phase.

If the horizontal phase shall not be influenced by RCV1, a horizontal pulse needs to be supplied at the RCV2 pin. Timing and trigger behaviour can be influenced for RCV2, as well.

If there are missing pulses at RCV1 and/or RCV2, the time base of DENC2-M runs free, thus an arbitrary number of sync slopes may miss, but no additional pulses (such with wrong phase) must occur.

If the vertical and horizontal phase is derived from RCV1, RCV2 can be used for horizontal or composite blanking input or output.

In the master mode, the time base of the circuit runs free continuously. On the RCV1 port, the IC can output :

- a Vertical Sync signal (VS) with 3 or 2.5 lines duration, or
- an ODD/EVEN signal which is low in odd fields, or
- a field sequence signal (FSEQ) which is high in the first of 4 resp. 8 fields.

On the RCV2 port, the IC can provide a horizontal pulse with programmable start and stop phase; this pulse can be inhibited in the vertical blanking period to build up e.g. a composite blanking signal.

The phase of the pulses output on RCV1 or RCV2 are related on the VP port, polarity of both signals is selectable.

The DENC2-M is **always** timing master for the source at the MP input. The IC provides two signals for synchronizing this source:

On the RCM1 port the same signals as on RCV1 (as output) are available; on RCM2 the IC provides a horizontal pulse with programmable start and stop phase.

The length of a field as well as start and end of its active part can be programmed. The active part of a field always starts at the beginning of a line.

### Control Interface

DENC2-M contains two control interfaces: An IIC slave transceiver and 8 bit parallel microprocessor interface. The interfaces cannot be used simultaneously.

The IIC bus interface is a standard slave transceiver, supporting 7 bit slave addresses and 100  $\frac{\text{kBit}}{\text{sec}}$  guaranteed transfer rate. It uses 8 bit subaddressing with auto-increment function. All registers are write-only, except one readable status byte.

Two IIC slave addresses can be selected (pin SEL\_MPU must be low !):

88h: Low at pin 61

8Ch: High at pin 61

The parallel interface is defined by

D(7-0) data bus

CSN low-active chip select signal

RWN read/write not signal, low for a write cycle

DTACKN 680XX style data acknowledge (hand-shake), active low

A0 register select, low selects address, high selects data

The parallel interface uses two registers, one auto-incremental containing the current address of a control register (equals subaddress with IIC control), one containing actual data. The currently addressed register is mapped to the corresponding control register.

Via a read access to the address register, the status byte can be read optionally; no other read access is provided.

### Input levels and formats

DENC2-M expects digital YUV data with levels (digital codes) acc to CCIR601:

Deviating amplitudes of the colour difference signals can be compensated by independent gain control setting, while gain for luminance is set to pre-defined values, distinguishable for 7.5 IRE setup or without setup.

The MPEG port accepts only 8 - bit multiplexed CCIR656 compatible data.

If the IIC bus interface is used, the VP port can handle both formats, 8 bit multiplexed CbYCr data on the VP lines, or the 16 bit DTV2 format with the Y signal on the VP lines and the UV signal on the DP port.

Reference levels are measured with a colour bar, 100% white, 100% amplitude, 100% saturation.

## Digital video encoder (DENC2-M)

SAA7188A

## CCIR signal component levels

Signal	IRE	dig. level	Code
Y	0	16	straight binary
	50	128	
	100	235	
Cb	bottom peak	16	straight binary
	colourless	128	
	top peak	240	
Cr	bottom peak	16	straight binary
	colourless	128	
	top peak	240	

## The 8 bit multiplexed format (CCIR656 like)

Time	0	1	2	3	4	5	6	7
Sample	Cb <sub>0</sub>	Y <sub>0</sub>	Cr <sub>0</sub>	Y <sub>1</sub>	Cb <sub>2</sub>	Y <sub>2</sub>	Cr <sub>2</sub>	Y <sub>3</sub>
Lum. pixel number	0		1		2		3	
Colour pixel number	0				2			

## The 16 bit multiplexed format (DTV2 format)

Time	0	1	2	3	4	5	6	7
Sample Y - line	Y <sub>0</sub>		Y <sub>1</sub>		Y <sub>2</sub>		Y <sub>3</sub>	
Sample UV - line	Cb <sub>0</sub>		Cr <sub>0</sub>		Cb <sub>2</sub>		Cr <sub>2</sub>	
Lum. pixel number	0		1		2		3	
Colour pixel number	0				2			

## Digital video encoder (DENC2-M)

SAA7188A

## Bit allocation map

Slave Receiver [ Slave Address 88h or 8Ch]

REGISTER FUNCTION	SUB-ADDR	DATA BYTE							
		D7	D6	D5	D4	D3	D2	D1	D0
NULL	00	0	0	0	0	0	0	0	0
.....									
NULL	39	0	0	0	0	0	0	0	0
Input_Port_Control	3A	CBENB	0	0	V656	VY2C	VUV2C	MY2C	MUV2C
OSD_LUT_Y0	42	OSDY07	OSDY06	OSDY05	OSDY04	OSDY03	OSDY02	OSDY01	OSDY00
OSD_LUT_U0	43	OSDU07	OSDU06	OSDU05	OSDU04	OSDU03	OSDU02	OSDU01	OSDU00
OSD_LUT_V0	44	OSDV07	OSDV06	OSDV05	OSDV04	OSDV03	OSDV02	OSDV01	OSDV00
.....									
OSD_LUT_Y7	57	OSDY77	OSDY76	OSDY75	OSDY74	OSDY73	OSDY72	OSDY71	OSDY70
OSD_LUT_U7	58	OSDU77	OSDU76	OSDU75	OSDU74	OSDU73	OSDU72	OSDU71	OSDU70
OSD_LUT_V7	59	OSDV77	OSDV76	OSDV75	OSDV74	OSDV73	OSDV72	OSDV71	OSDV70
Chroma_Phase	5A	CHPS7	CHPS6	CHPS5	CHPS4	CHPS3	CHPS2	CHPS1	CHPS0
Gain_U	5B	GAINU7	GAINU6	GAINU5	GAINU4	GAINU3	GAINU2	GAINU1	GAINU0
Gain_V	5C	GAINV7	GAINV6	GAINV5	GAINV4	GAINV3	GAINV2	GAINV1	GAINV0
Gain_U_MSB, Black_Lev	5D	GAINU8	0	BLCKL5	BLCKL4	BLCKL3	BLCKL2	BLCKL1	BLCKL0
Gain_V_MSB, Blank_Lev	5E	GAINV8	0	BLNNL5	BLNNL4	BLNNL3	BLNNL2	BLNNL1	BLNNL0
NULL	5F	0	0	0	0	0	0	0	0
X-Col_Select	60	CCRS1	CCRS0	0	0	0	0	0	0
Standard_Control	61	0	DOWN	INPI1	YGS	RTCE	SCBW	PAL	FISE
Burst_Amplitude	62	SQP	BSTA6	BSTA5	BSTA4	BSTA3	BSTA2	BSTA1	BSTA0
Subcarrier_0	63	FSC07	FSC06	FSC05	FSC04	FSC03	FSC02	FSC01	FSC00
Subcarrier_1	64	FSC15	FSC14	FSC13	FSC12	FSC11	FSC10	FSC09	FSC08
Subcarrier_2	65	FSC23	FSC22	FSC21	FSC20	FSC19	FSC18	FSC17	FSC16
Subcarrier_3	66	FSC31	FSC30	FSC29	FSC28	FSC27	FSC26	FSC25	FSC24
Line21_Odd_0	67	L21O07	L21O06	L21O05	L21O04	L21O03	L21O02	L21O01	L21O00
Line21_Odd_1	68	L21O17	L21O16	L21O15	L21O14	L21O13	L21O12	L21O11	L21O10
Line21_Even_0	69	L21E07	L21E06	L21E05	L21E04	L21E03	L21E02	L21E01	L21E00
Line21_Even_1	6A	L21E17	L21E16	L21E15	L21E14	L21E13	L21E12	L21E11	L21E10
Encod_Ctrl,CC_Line	6B	MODIN1	MODIN0	0	SCCLN4	SCCLN3	SCCLN2	SCCLN1	SCCLN0
RCV_Port_Control	6C	SRCV11	SRCV10	TRCV2	ORCV1	PRCV1	CBLF	ORCV2	PRCV2
RCM, CC-Mode	6D	0	0	0	0	SRCM11	SRCM10	CCEN1	CCEN0
H-Trigger	6E	HTRIG7	HTRIG6	HTRIG5	HTRIG4	HTRIG3	HTRIG2	HTRIG1	HTRIG0
H-Trigger	6F	0	0	0	0	0	HTRIG10	HTRIG09	HTRIG08

## Digital video encoder (DENC2-M)

SAA7188A

## Slave Receiver [ Slave Address 88h or 8Ch]

REGISTER FUNCTION	SUB-ADDR	DATA BYTE							
		D7	D6	D5	D4	D3	D2	D1	D0
Fsc_Res_Mode, V-Trigger	70	PHRES1	PHRES0	SBLBN	VTRIG4	VTRIG3	VTRIG2	VTRIG1	VTRIG0
Begin_MP_Request	71	BMRQ7	BMRQ6	BMRQ5	BMRQ4	BMRQ3	BMRQ2	BMRQ1	BMRQ0
End_MP_Request	72	EMRQ7	EMRQ6	EMRQ5	EMRQ4	EMRQ3	EMRQ2	EMRQ1	EMRQ0
MSBs_MP_Request	73	0	EMRQ10	EMRQ09	EMRQ08	0	BMRQ10	BMRQ09	BMRQ08
NULL	74	0	0	0	0	0	0	0	0
NULL	75	0	0	0	0	0	0	0	0
NULL	76	0	0	0	0	0	0	0	0
Begin_RCV2_out	77	BRCV7	BRCV6	BRCV5	BRCV4	BRCV3	BRCV2	BRCV1	BRCV0
End_RCV2_out	78	ERCV7	ERCV6	ERCV5	ERCV4	ERCV3	ERCV2	ERCV1	ERCV0
MSBs_RCV2_out	79	0	ERCV10	ERCV09	ERCV08	0	BRCV10	BRCV09	BRCV08
Field_Length	7A	FLEN7	FLEN6	FLEN5	FLEN4	FLEN3	FLEN2	FLEN1	FLEN0
First_Act_Line	7B	FAL7	FAL6	FAL5	FAL4	FAL3	FAL2	FAL1	FAL0
Last_Act_Line	7C	LAL7	LAL6	LAL5	LAL4	LAL3	LAL2	LAL1	LAL0
MSBs_Field_Ctrl	7D	0	0	LAL8	FAL8	0	0	FLEN9	FLEN8

## Note :

All bits labelled '0' are reserved. They **must** be programmed with 0.

I<sup>2</sup>C-Bus Format

S	Slave Address	A	Subaddress	A	DATA 0	A	-----	DATA n	A	P
---	---------------	---	------------	---	--------	---	-------	--------	---	---

Portion	Meaning
S	start condition
Slave Address	1000100X or 1000110X
A	acknowledge, generated by the slave
Subaddress(*)	subaddress byte
DATA	data byte
-----	continued data bytes and A's
P	stop condition
	X: read/write control bit; X=0 is order to write; X=1 is order to read, no subaddressing with read.

(\*) if more than 1 byte DATA is transmitted, then auto-increment of the subaddress is performed.

## Digital video encoder (DENC2-M)

SAA7188A

## Slave Receiver

## Subaddress 3A:

MUV2C	0	Cb/Cr data at MP are two's complement
	1	Cb/Cr data at MP are straight binary (default after reset)
MY2C	0	Y data at MP are two's complement
	1	Y data at MP are straight binary (default after reset)
VUV2C	0	Cb/Cr data input to VP or DP are two's complement (default after reset)
	1	Cb/Cr data input to VP or DP are straight binary
VY2C	0	Y data input to VP are two's complement (default after reset)
	1	Y data input to VP are straight binary
V656	0	Selects YUV 422 format on VP (8 lines Y) and DP (8 lines multiplexed Cb/Cr)
	1	Selects CCIR 656 compatible format on VP (8 lines Cb,Y,Cr,Y) (default after reset)
CBENB	0	Data from input ports are encoded (default after reset)
	1	Colour Bar with programmable colours (entries of OSD-LUTs) is encoded The LUTs are read in upward order from index 0 to index 7.

## Subaddress 42 .. 59:

OSDY OSDU OSDV	Contents of OSD Look-up tables. All 8 entries are 8 bits. Data representation is acc. to CCIR 601 [Y,Cb,Cr], but two's complement, e.g. for a 100/100 [upper number] or 100/75 [lower number] Colour Bar:				
	Colour	OSDY	OSDU	OSDV	index (for normal colour bar with CBENB = 1)
White	107 (6Bh)	0 (00h)	0 (00h)	0 (00h)	0
	107 (6Bh)	0 (00h)	0 (00h)	0 (00h)	
Yellow	82 (52h)	144 (90h)	18 (12h)	14 (0Eh)	1
	34 (22h)	172 (ACH)	14 (0Eh)	14 (0Eh)	
Cyan	42 (2Ah)	38 (26h)	144 (90h)	172 (ACH)	2
	03 (03h)	29 (1Dh)	172 (ACH)	172 (ACH)	
Green	17 (11h)	182 (B6h)	162 (A2h)	185 (B9h)	3
	240 (F0h)	200 (C8h)	185 (B9h)	185 (B9h)	
Magenta	234 (EAh)	74 (4Ah)	94 (5Eh)	71 (47h)	4
	212 (D4h)	56 (38h)	71 (47h)	71 (47h)	
Red	209 (D1h)	218 (DAh)	112 (70h)	84 (54h)	5
	193 (C1h)	227 (E3h)	112 (70h)	84 (54h)	
Blue	169 (A9h)	112 (70h)	238 (EEh)	242 (F2h)	6
	163 (A3h)	84 (54h)	238 (EEh)	242 (F2h)	
Black	144 (90h)	0 (00h)	0 (00h)	0 (00h)	7
	144 (90h)	0 (00h)	0 (00h)	0 (00h)	

## Subaddress 5A:

CHPS	Phase of encoded colour subcarrier (including burst) relative to H - sync. Can be adjusted in steps of 360/256 degrees.
------	---

## Digital video encoder (DENC2-M)

SAA7188A

**Subaddress 5B, 5D:**

GAINU	<p>Variable gain for Cb signal (Input Representation acc. to CCIR 601) White - Black = 92.5 IRE</p> <p>White - Black = 92.5 IRE</p> <p>GAINU=0                      Output subcarrier of U contribution = 0</p> <p>GAINU=118 (76h)            Output subcarrier of U contribution = nominal</p> <p>GAINU = -2.17 * nominal ... nominal ... 2.16 * nominal</p> <p>White - Black = 100 IRE</p> <p>GAINU=0                      Output subcarrier of U contribution = 0</p> <p>GAINU=125 (7Dh)            Output subcarrier of U contribution = nominal</p> <p>GAINU = -2.05 * nominal ... nominal ... 2.04 * nominal</p>
-------	--

**Subaddress 5C, 5E:**

GAINV	<p>Variable gain for Cr signal (Input Representation acc. to CCIR 601)</p> <p>White - Black = 92.5 IRE</p> <p>GAINV=0                      Output subcarrier of V contribution = 0</p> <p>GAINV=165 (A5h)            Output subcarrier of V contribution = nominal</p> <p>GAINV = -1.55 * nominal ... nominal ... 1.55 * nominal</p> <p>White-Black = 100 IRE</p> <p>GAINV=0                      Output subcarrier of V contribution = 0</p> <p>GAINV=175 (AFh)            Output subcarrier of V contribution = nominal</p> <p>GAINV = -1.46 * nominal ... nominal ... 1.46 * nominal</p>
-------	---

**Subaddress 5D:**

BLCKL	<p>Variable Black Level (Input Representation acc. to CCIR 601)</p> <p>White - Sync = 140 IRE</p> <p>BLCKL= 0                      Output Black Level = 24 IRE</p> <p>BLCKL= 63 (3Fh)            Output Black Level = 49 IRE</p> <p>Output Black Level/IRE = BLCKL * 25/63 + 24</p> <p>Recommended Value : BLCKL = 60 (3Ch) (normal)</p> <p>White-Sync = 143 IRE</p> <p>BLCKL= 0                      Output Black Level = 24 IRE</p> <p>BLCKL= 63 (3Fh)            Output Black Level = 50 IRE</p> <p>Output Black Level/IRE = BLCKL * 26/63 + 24</p> <p>Recommended Value : BLCKL = 45 (2Dh) (normal)</p>
-------	---

## Digital video encoder (DENC2-M)

SAA7188A

**Subaddress 5E:**

BLNNL	Variable Blanking Level
	<p>White - Sync = 140 IRE</p> <p>BLNNL= 0      Output Blanking Level = 17 IRE</p> <p>BLNNL= 63 (3Fh)      Output Blanking Level = 42 IRE</p> <p>Output Blanking Level/IRE = <math>BLNNL * 25/63 + 17</math></p> <p>Recommended Value : BLNNL = 58 (3Ah) (normal)</p> <p>White - Sync = 143 IRE</p> <p>BLNNL= 0      Output Blanking Level = 17 IRE</p> <p>BLNNL= 63 (3Fh)      Output Blanking Level = 43 IRE</p> <p>Output Blanking Level/IRE = <math>BLNNL * 26/63 + 17</math></p> <p>Recommended Value : BLNNL = 63 (3Fh) (normal)</p>

**Subaddress 60:**

CCRS	Select cross colour reduction filter in luminance		
	CCRS1	CCRS0	function
	0	0	No Cross Colour Reduction (for overall transfer characteristic of luminance see fig. 5)
	0	1	Cross Colour Reduction #1 active (for overall transfer characteristic see fig. 5)
	1	0	Cross Colour Reduction #2 active (for overall transfer characteristic see fig. 5)
1	1	Cross Colour Reduction #3 active (for overall transfer characteristic see fig. 5)	

**Subaddress 61:**

FISE	0	864 total pixel clocks per line
	1	858 total pixel clocks per line (default after reset)
PAL	0	NTSC Encoding (non-alternating V-component) (default after reset)
	1	PAL Encoding (alternating V-component)
SCBW	0	Enlarged Bandwidth for Chrominance Encoding (for overall transfer characteristic of chrominance in base-band representation see figs. 3 and 4).
	1	Standard Bandwidth for Chrominance Encoding (for overall transfer characteristic of chrominance in base-band representation see figs. 3 and 4). (default after reset)
RTCE	0	No Real Time Control of generated Subcarrier Frequency (default after reset)
	1	Real Time Control of generated Subcarrier Frequency through SAA7151B (timing see fig. 9)
YGS	0	Luminance Gain for White-Black 100 IRE
	1	Luminance Gain for White-Black 92.5 IRE incl. 7.5 IRE Set-up of Black (default after reset)
INPI	0	PAL Switch phase is nominal (default after reset)
	1	PAL Switch phase is inverted compared to nominal
DOWN	0	DACs in normal operational mode (default after reset)
	1	DACs forced to lowest output voltage

## Digital video encoder (DENC2-M)

SAA7188A

## Subaddress 62:

BSTA	<p>Amplitude of Colour Burst (Input Representation acc. to CCIR 601)</p> <p>White-Black = 92.5 IRE, Burst = 40 IRE, NTSC-Encoding</p> <p>BSTA = 0 .. 1.25 * nominal</p> <p>Recommended Value : BSTA = 102(66h)</p> <p>White-Black = 92.5 IRE, Burst = 40 IRE, PAL-Encoding</p> <p>BSTA = 0 .. 1.76 * nominal</p> <p>Recommended Value : BSTA = 72(48h)</p> <p>White-Black = 100 IRE, Burst = 43 IRE, NTSC-Encoding</p> <p>BSTA = 0 .. 1.20 * nominal</p> <p>Recommended Value : BSTA = 106(6Ah)</p> <p>White-Black = 100 IRE, Burst = 43 IRE, PAL-Encoding</p> <p>BSTA = 0 .. 1.67 * nominal</p> <p>Recommended Value : BSTA = 75(4Bh)</p>
SQP	<p>0 Subcarrier Real Time Control from 7151B Digital Colour Decoder</p> <p>1 not supported in current version, do not use.</p>

Note to subaddresses 5B,5C,5D,5E,62: All IRE values are rounded

## Subaddress 63 .. 66 :

FSC0	Four bytes to program subcarrier frequency	
...		$F(fsc)$ Subcarrier frequency (in multiples of line frequency)
FSC3		$F(llc)$ Clock frequency (in multiples of line frequency)
	$FSC = \text{round} \left( \frac{F(fsc)}{F(llc)} \times 2^{32} \right)$	FSC3 Most significant byte
		FSC0 Least significant byte
	Examples:	
	NTSC-M : $F(fsc) = 227.5$ , $F(llc) = 1716$ ==>	FSC = 569408543 (21F07C1Fh)
	PAL-B/G : $F(fsc) = 283.7516$ , $F(llc) = 1728$ ==>	FSC = 705268427 (2A098ACBh)

## Subaddress 67 .. 6A:

L21OD2	First Byte of Captioning Data, Odd Field
L21OD3	Second Byte of Captioning Data, Odd Field
L21ED0	First Byte of Extended Data, Even Field
L21ED1	Second Byte of Extended Data, Even Field
	<p>LSBs of the respective bytes are encoded immediately after run-in and framing code, the MSBs of the respective bytes have to carry the parity bit, acc. to the definition of line 21 encoding format.</p>



## Digital video encoder (DENC2-M)

SAA7188A

**Subaddress 6B**

SCCLN	Selects the actual line, where Closed Caption or Extended Data are encoded. Line = (SCCLN + 4) for M-systems Line = (SCCLN + 1) for other systems		
MODIN	Defines video data of MP port or VP(DP) port to be encoded		
	MODIN1	MODIN0	
	0	0	unconditionally from MP port
	0	1	from MP port, if pin SEL_ED=high, else from VP port
	1	0	unconditionally from VP port
	1	1	from VP port, if pin SEL_ED=high, else from MP port

**Subaddress 6C:**

PRCV2	0 Polarity of RCV2 as output is high-active, rising edge is taken when input, respectively (default after reset). 1 Polarity of RCV2 as output is low-active, falling edge is taken when input, respectively				
ORCV2	0 Pin RCV2 is switched to input (default after reset). 1 Pin RCV2 is switched to output				
CBLF	0 If ORCV2=high, pin RCV2 provides a HREF signal (Horizontal Reference Pulse that is high during active portion of line, also during Vertical Blanking Interval). (default after reset) If ORCV2=low, signal input to RCV2 is used for horizontal synchronization only (if TRCV2 = 1). (default after reset) 1 If ORCV2=high, pin RCV2 provides a CBN signal (Reference Pulse that is high during active video, excluding Vertical Blanking Interval). If ORCV2=low, signal input to RCV2 is used for horizontal synchronization (if TRCV2 = 1) as well as an internal blanking signal				
PRCV1	0 Polarity of RCV1 as output is high-active, rising edge is taken when input, respectively. (default after reset) 1 Polarity of RCV1 as output is low-active, falling edge is taken when input, respectively.				
ORCV1	0 Pin RCV1 is switched to input (default after reset). 1 Pin RCV1 is switched to output.				
TRCV2	0 Horizontal synchronization is taken from RCV1 port. (default after reset) 1 Horizontal synchronization is taken from RCV2 port.				
SRCV1	Defines signal type on pin RCV1				
	SRCV11	SRCV10	as output	as input	
	0	0	VS	VS	Vertical Sync each field (default after reset)
	0	1	FS	FS	Frame Sync (_odd/even)
	1	0	FSEQ	FSEQ	Field SEQUENCE, Vertical sync every fourth (FISE=1) or eighth field (FISE=0)
	1	1	n.a.	n.a.	

## Digital video encoder (DENC2-M)

SAA7188A

**Subaddress 6D:**

CCEN	Enables individual Line 21 Encoding			
	CCEN1	CCEN0		
	0	0	Line 21 Encoding OFF	
	0	1	Enables Encoding in field 1 (odd)	
	1	0	Enables Encoding in field 2 (even)	
	1	1	Enables Encoding in both fields	
SRCM	Defines signal type on pin RCM1			
	SRCM1	SRCM0	as output	
	0	0	VS	Vertical Sync each field
	0	1	FS	Frame Sync (_odd/even)
	1	0	FESQ	Field SEquence, Vertical sync every fourth (FISE=1) or eight field (FISE=0)
	1	1	n.a.	

**Subaddress 6E .. 6F:**

HTRIG	<p>Sets the Horizontal TRIGger phase related to signal on RCV1 or RCV2 input.</p> <p>Values above 1715 (FISE=1) or 1727 [FISE=0] are not allowed.</p> <p>Increasing HTRIG decreases delays of all internally generated timing signals.</p> <p>Reference mark : Analog output horizontal sync (leading slope) coincides with active edge of RCV used for triggering at HTRIG = 032h [032h]</p>
-------	---

**Subaddress 70:**

VTRIG	<p>Sets the Vertical TRIGger phase related to signal on RCV1 input.</p> <p>Increasing VTRIG decreases delays of all internally generated timing signals, measured in half lines</p> <p>Variation range of VTRIG = 0 .. 31(1Fh)</p>		
SBLBN	<p>0 Vertical Blanking is defined by programming of FAL and LAL .</p> <p>1 Vertical Blanking is forced automatically at least during field synchronization and equalization pulses.</p> <p>Note: If Cross-Colour Reduction is programmed, it is active between FAL and LAL in both cases.</p>		
PHRES	Selects the phase reset mode of the colour subcarrier generator		
	PHRES1	PHRES0	
	0	0	no reset
	0	1	reset every two lines
	1	0	reset every eight fields
	1	1	reset every four fields

## Digital video encoder (DENC2-M)

SAA7188A

**Subaddress 71 .. 73:**

BMRQ	<p>Begin of MP ReQuest signal (RCM2).</p> <p>Values above 1715 (FISE=1) or 1727 [FISE=0] are not allowed.</p> <p>First active pixel at analog outputs (corresp. input pixel coinciding with RCM2) at BMRQ=0F9h [115h]</p>
EMRQ	<p>End of MP ReQuest signal (RCM2).</p> <p>Values above 1715 (FISE=1) or 1727 [FISE=0] are not allowed.</p> <p>Last active pixel at analog outputs (corresp. input pixel coinciding with RCM2) at EMRQ=686h [690h]</p>

**Subaddress 77 .. 79:**

BRCV	<p>Begin of output signal on RCV2 pin.</p> <p>Values above 1715 (FISE=1) or 1727 [FISE=0] are not allowed.</p> <p>First active pixel at analog outputs (corresp. input pixel coinciding with RCV2) at BRCV=0F9h [115h]</p>
ERCV	<p>End of output signal on RCV2 pin.</p> <p>Values above 1715 (FISE=1) or 1727 [FISE=0] are not allowed.</p> <p>Last active pixel at analog outputs (corresp. input pixel coinciding with RCV2) at ERCV=686h [690h]</p>

**Subaddress 7A .. 7D:**

FLEN	<p>LENgth of a Field = FLEN + 1, measured in half lines</p> <p>Valid range is limited to 524 .. 1022 (FISE=1) resp. 624 .. 1022 (FISE=0), FLEN should be even</p>
FAL	<p>First Active Line after vertical blanking interval = FAL + 1, measured in lines.</p> <p>FAL=0 coincides with the first field synchronization pulse.</p>
LAL	<p>Last Active Line before vertical blanking interval = LAL + 1, measured in lines</p> <p>LAL=0 coincides with the first field synchronization pulse.</p>

## Digital video encoder (DENC2-M)

SAA7188A

**Slave Transmitter****Slave Transmitter [Slave Address 89h or 8Dh]**

REGISTER FUNCTION	SUB- ADDR	DATA BYTE							
		D7	D6	D5	D4	D3	D2	D1	D0
Status Byte	-	VER2	VER1	VER0	CCRDE	CCRDO	FSQ2	FSQ1	FSQ0

**no subaddress**

VER	Version id of the device. It will be changed with all versions of the IC that have different programming models Current Version is 011 bin.
CCRDE	Closed caption bytes of the even field have been encoded. The bit is reset after information has been written to the subaddresses 69,6A. It is set immediately after the data have been encoded.
CCRDO	Closed caption bytes of the odd field have been encoded. The bit is reset after information has been written to the subaddresses 67,68. It is set immediately after the data have been encoded.
FSQ	State of the internal field sequence counter. Bit 0 (FSQ0) gives the odd/even information. (Odd=Low, Even=High)

Digital video encoder (DENC2-M)

SAA7188A

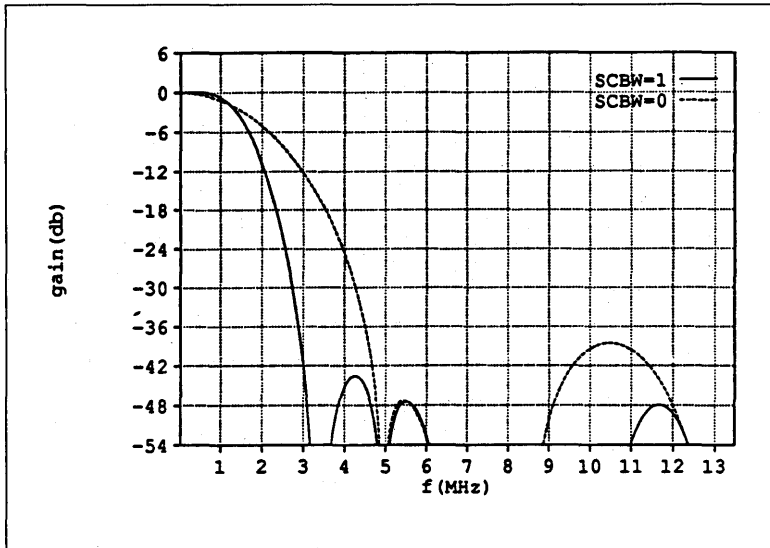

Fig. 3 : Chrominance transfer characteristic

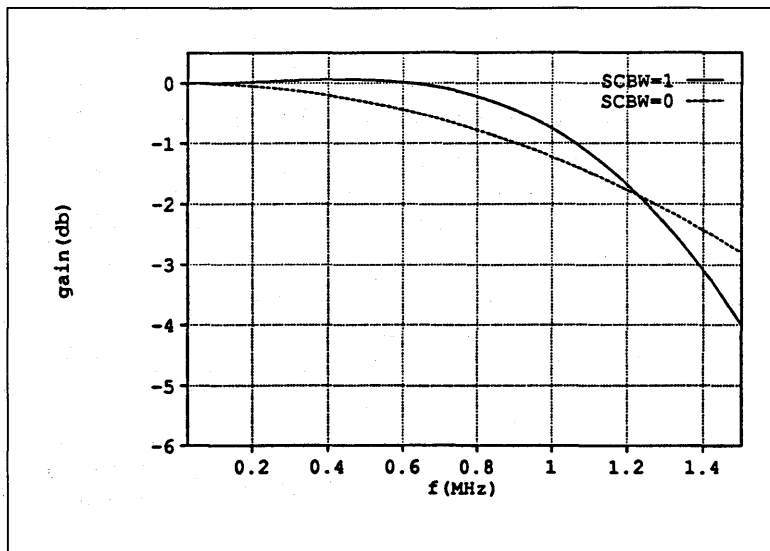

Fig. 4 : Chrominance transfer characteristic

Digital video encoder (DENC2-M)

SAA7188A

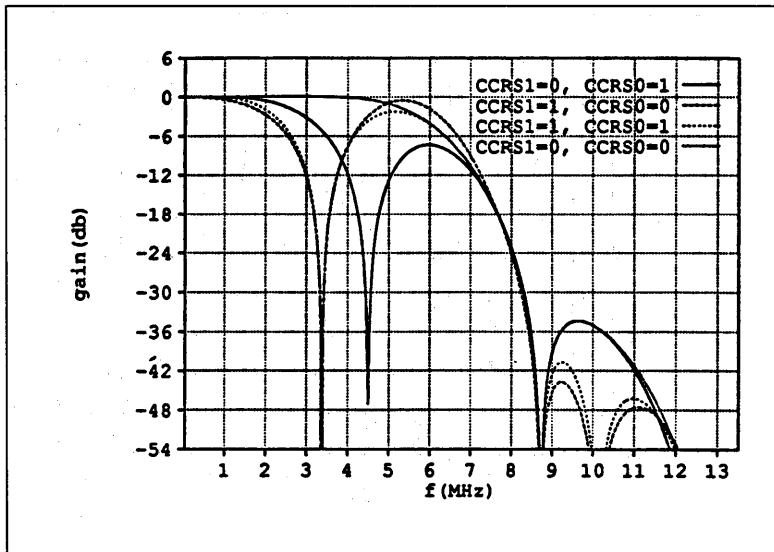

Fig. 5 : Luminance transfer characteristic

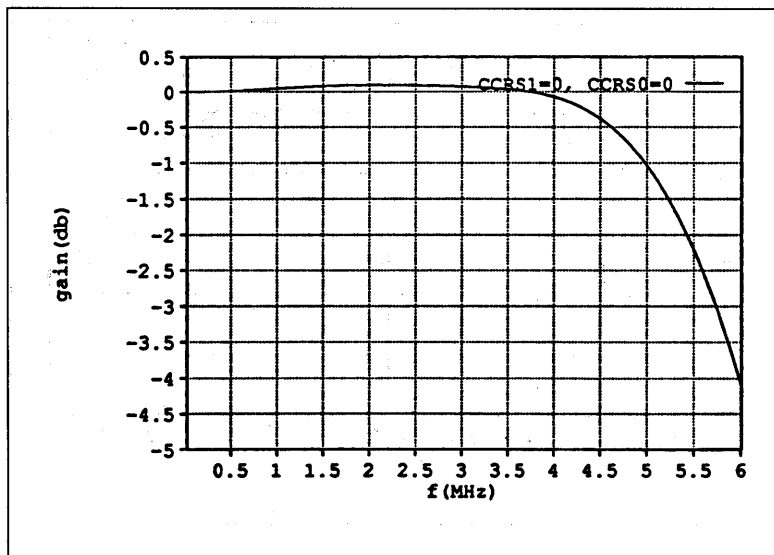

Fig.6 : Luminance transfer characteristic

## Digital video encoder (DENC2-M)

SAA7188A

## Electrical Characteristics

Conditions :  $T_{amb} = 0 \dots 70 \text{ }^\circ\text{C}$ ;  $V_{DDD} = 4.5 \dots 5.5 \text{ V}$  unless otherwise specified.

SYMBOL	PARAMETER	TEST CONDITIONS	LIMITS		UNIT
			MIN	MAX	
<b>Supply</b>					
$V_{DDD}$	supply voltage range digital		4.5	5.5	V
$V_{DDA}$	supply voltage range analog		4.75	5.25	V
$I_{DDD}$	supply current	1)	-	170	mA
$I_{DDA}$	supply current	1)	-	55	mA
<b>Inputs</b>					
$V_{IL}$	input voltage LOW (except LLC, SDA, SCL, AP, SP, XTALI)		-0.5	0.8	V
$V_{IH}$	input voltage HIGH (except LLC, SDA, SCL, AP, SP, XTALI)		2.0	$V_{DDD}+0.5$	V
$V_{IH}$	input voltage HIGH (LLC pin 38)		2.4	$V_{DDD}+0.5$	V
$I_{LI}$	input leakage current		-	1	$\mu\text{A}$
$C_I$	input capacitance	clocks	-	10	pF
$C_I$	input capacitance	data		8	pF
$C_I$	input capacitance	I/O at high impedance		8	pF
<b>Outputs</b>					
$V_{OL}$	output voltage LOW (except XTAL, SDA)	2)	0	0.6	V
$V_{OH}$	output voltage HIGH (except LLC, XTAL, DTACKN, SDA)	2)	2.4	$V_{DDD}+0.5$	V
$V_{OH}$	output voltage HIGH (LLC pin 38)	2)	2.6	$V_{DDD}+0.5$	V
<b>I<sup>2</sup>C Bus SDA and SCL</b>					
$V_{IL}$	input voltage LOW		-0.5	1.5	V
$V_{IH}$	input voltage HIGH		3.0	$V_{DDD}+0.5$	V
$I_I$	input current	$V_I = \text{low or high}$		$\pm 10$	$\mu\text{A}$
$V_{OL}$	SDA output voltage	$I_O = 3 \text{ mA}$		0.4	V
$I_O$	output current	during acknowl.	3		mA
<b>Clock timing</b>					
$t_{LLC}$	cycle time LLC	3)	34	41	ns
$\delta$	duty factor $t_{LLCh} / t_{LLC}$	10)	40	60	%
$t_r$	rise time LLC	3)	-	5	ns
$t_f$	fall time LLC	3)	-	6	ns
<b>Input timing</b>					
$t_{SUC}$	input data setup time (CREF)		6	-	ns
$t_{HDC}$	input data hold time (CREF)		3	-	ns

## Digital video encoder (DENC2-M)

SAA7188A

SYMBOL	PARAMETER	TEST CONDITIONS	LIMITS		UNIT
			MIN	MAX	
$t_{SU}$	input data setup time (any other except SEL_MPU, CDIR, RWN/SCL, A0/SDA, CSN/SA, RESN, AP, SP)		6	-	ns
$t_{HD}$	input data hold time (any other except SEL_MPU, CDIR, RWN/SCL, A0/SDA, CSN/SA, RESN, AP, SP)		3	-	ns
<b>Crystal Oscillator</b>					
$f_n$	nominal frequency (usually 27 MHz)	3rd harmonic	-	30	MHz
$Df/f_n$	permissible deviation $f_n$	9)	-50	+50	$10^{-6}$
	crystal specification:				
	temperature range $T_{amb}$		0	70	C
	load capacitance $C_L$		8	-	pF
	series resonance resistance $R_S$			80	$\Omega$
	motional capacitance $C_1$	typically	1.5-20%	1.5+20%	fF
	parallel capacitance $C_0$	typically	3.5-20%	3.5+20%	pF
<b>MPU interface timing</b>					
$t_{AS}$	address setup time	5)	9	-	ns
$t_{AH}$	address hold time		0	-	ns
$t_{RWS}$	read/write setup time	5)	9	-	ns
$t_{RWH}$	read/write hold time		0	-	ns
$t_{DD}$	data valid from CSN (read)	6), 7), 8), n=9	-	400	ns
$t_{DF}$	data bus floating from CSN (read)	6), 7), n=5	-	255	ns
$t_{DS}$	data bus setup time (write)	5)	9	-	ns
$t_{DH}$	data bus hold time (write)	5)	9	-	ns
$t_{ACS}$	acknowledge delay from CSN	6), 7), n=11	-	475	ns
$t_{CSD}$	CSN high from acknowledge		0	-	ns
$t_{DAT}$	DTACKN floating from CSN high	6), 7), n=7	-	330	ns
<b>Data and reference signal output timing</b>					
$C_L$	output load capacitance		7.5	40	pF
$t_{OH}$	output hold time		4	-	ns
$t_{OD}$	output delay time (CREF in output mode)		-	25	ns
<b>C, Y, and CVBS outputs</b>					
$V_o$	output signal (peak to peak value)	4)	1.9	2.1	V
$R_I$	internal serial resistance		18	35	$\Omega$
$R_L$	output load resistance		80	-	$\Omega$
B	output signal bandwidth (D/A-convertors)	-3dB	10	-	MHz
ILE	LF integral linearity error (D/A-convertors)		-	$\pm 2$	LSB
DLE	LF differential linearity error (D/A-convertors)		-	$\pm 1$	LSB



# Digital video encoder (DENC2-M)

# SAA7188A

**Notes :**

- 1) At maximum supply voltage with highly active input signals.
- 2) The levels have to be measured with load circuits of 1.2 kΩ to 3.0 V (standard TTL load),  $C_L = 25\text{pF}$ .
- 3) The data is for both, input and output direction.
- 4) for full digital range, without load,  $V_{DDA} = 5.0\text{ V}$ . The typical voltage swing is 2.0 V, the typical minimum output voltage (digital zero at DAC) is 0.2 V.
- 5) The value is calculated via equation (1)
- 6) The value depends on the clock frequency. The numbers given are calculated with  $f_{LLC} = 27\text{ MHz}$
- 7) The values are calculated via equation (2)
- 8) The falling edge of DTACKN will always occur 1 \* LLC after data is valid.
- 9) If internal oscillator is used, crystal deviation of  $f_n$  is directly proportional to the deviation of subcarrier frequency and line/ field frequency.
- 10) With LLC in input mode. In output mode, with a crystal connected to XTAL/ XTALI typically 50 %.

**Equations:**

- (1)  $t = t_{SU} + t_{HD}$
- (2)  $t_{dmax} = t_{OD} + n * t_{LLC} + t_{LLC} + t_{SU}$

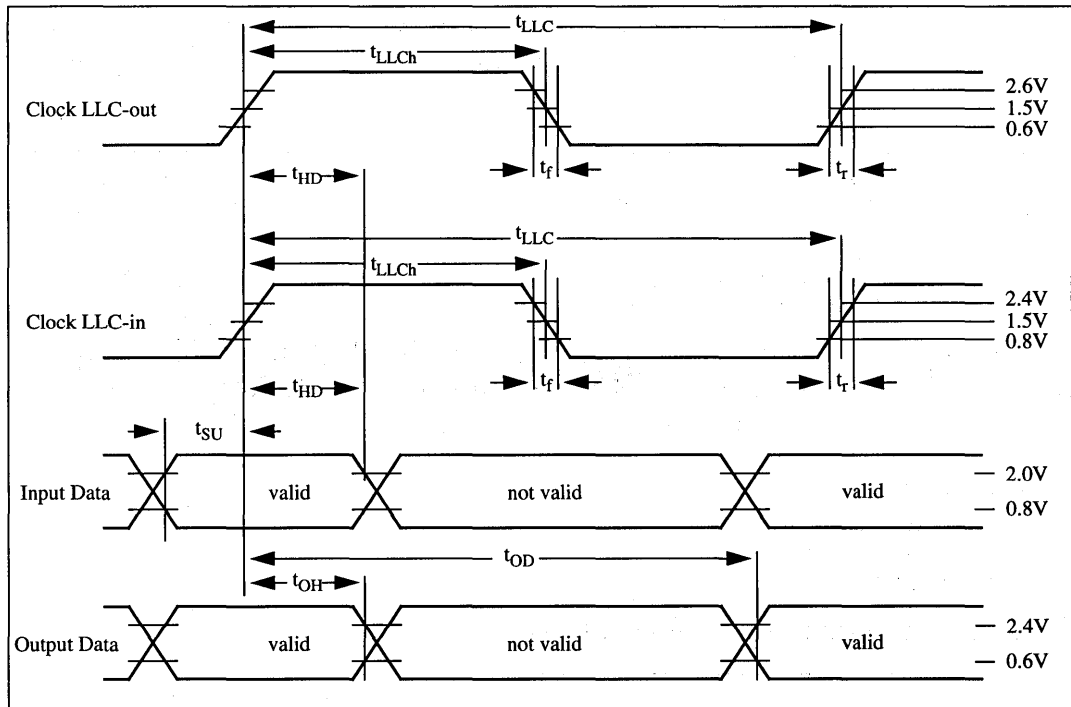

**Fig. 7 : Clock Data Timing**

Digital video encoder (DENC2-M)

SAA7188A

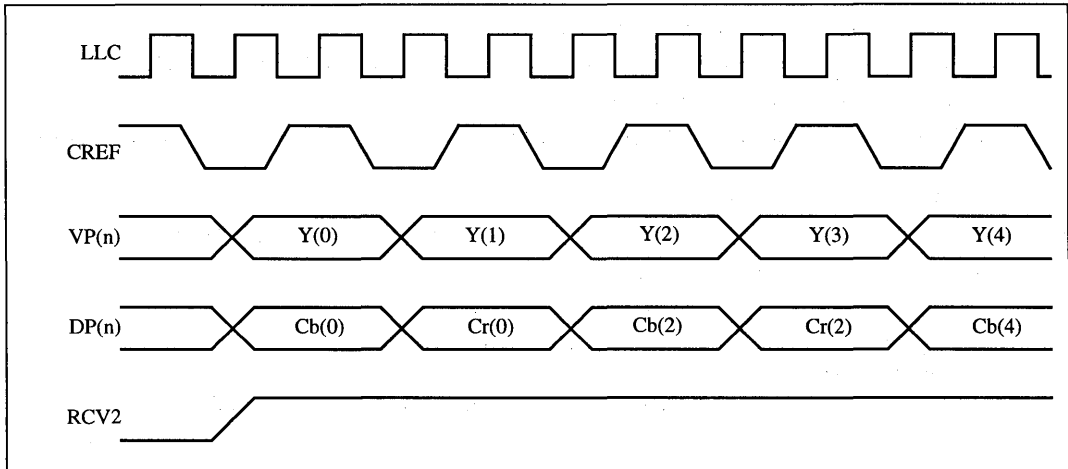

Fig.8 : Dig.TV - Timing

Notes :

- 1) The data demultiplex phase is coupled to the internal horizontal phase.
- 2) The CREF signal applies only for the 16 lines DIG-TV format, because these signals are only valid in 13.5 MHz.
- 3) The phase of the RCV2 signal is programmed to 0F9h [ 115h for 50 Hz ] in this example in output mode (BRCV2)

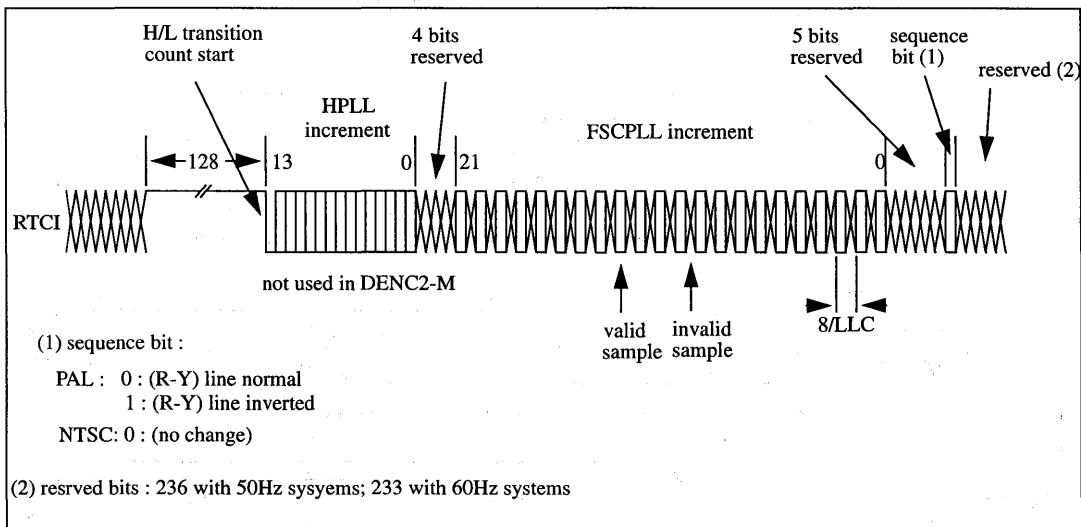

Fig.9 : RTCI timing

Digital video encoder (DENC2-M)

SAA7188A

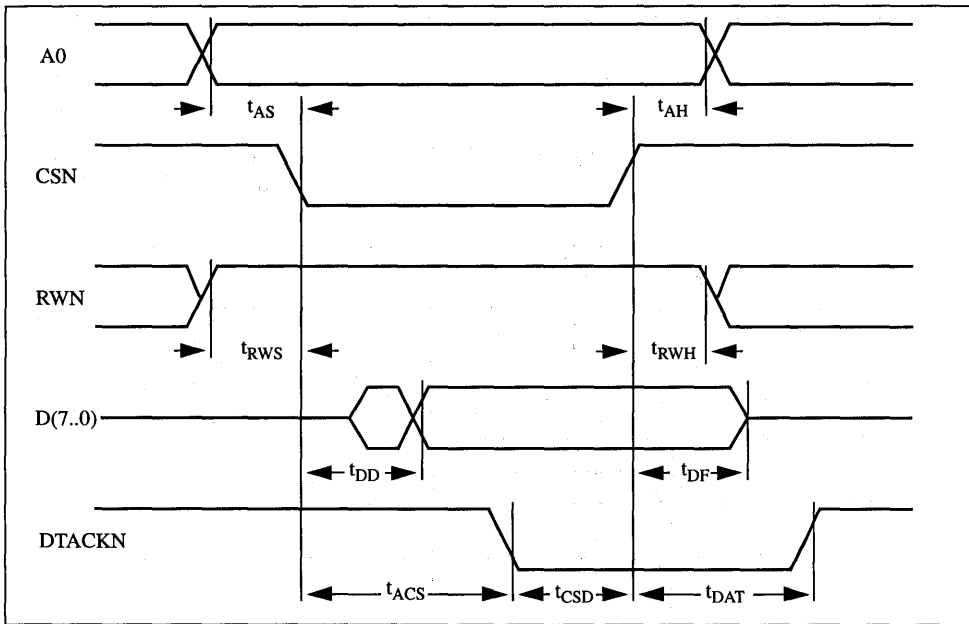

Fig.10 : MPU Interface Timing (Read cycle)

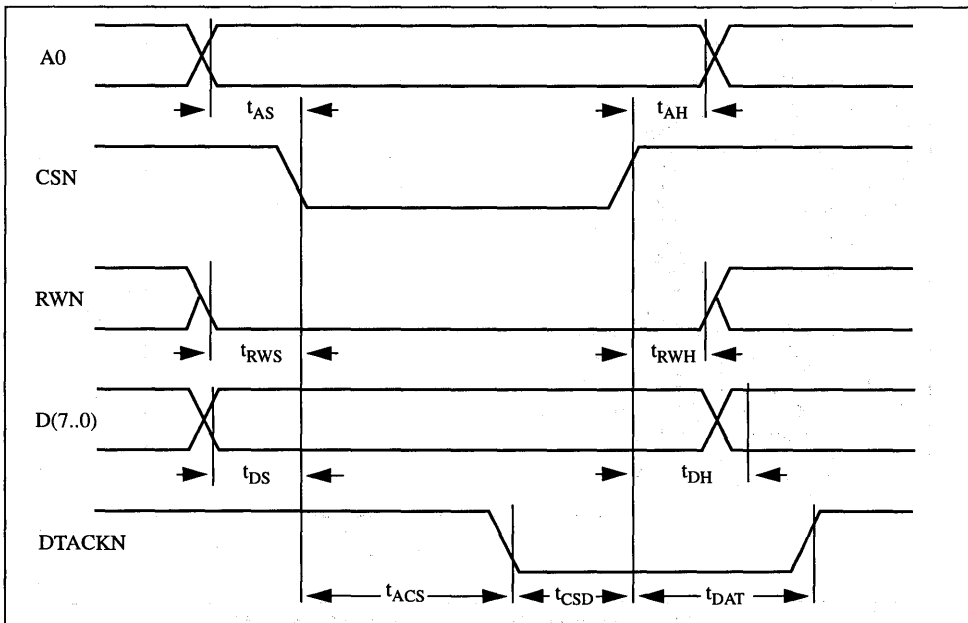

Fig.11 : MPU Interface Timing (Write cycle)



## SAA7188A programming example

### SAA7188A PROGRAMMING EXAMPLE

SUB ADDR	DATA	FUNCTION
0-39	00	NULL
3A	5F	Input Port Control – DF selects internal color bars – MP port used – 8 bit mux'd data
3B-41	00	NULL
42	6B	OSD Y-0
43	00	OSD U-0 WHITE
44	00	OSD V-0
45	1D	OSD Y-1
46	AD	OSD U-1 YELLOW
47	0E	OSD V-1
48	00	OSD Y-2
49	1D	OSD U-2 CYAN
4A	AD	OSD V-2
4B	EC	OSD Y-3
4C	CA	OSD U-3 GREEN
4D	BB	OSD V-3
4E	CF	OSD Y-4
4F	3A	OSD U-4 MAGENTA
50	46	OSD V-4
51	BC	OSD Y-5
52	E5	OSD U-5 RED
53	54	OSD V-5
54	9E	OSD Y-6
55	55	OSD U-6 BLUE
56	F1	OSD V-6
57	90	OSD Y-7
58	00	OSD U-7 BLACK
59	00	OSD V-7
5A	3F	Chroma Phase
5B	79	Gain U Axis
5C	AD	Gain V Axis
5D	3C	Black Level
5E	3A	Blanking Level
5F	00	NULL
60	38	Cross Color Reduction Filter Select
61	15	Standard Control
62	69	Burst Amplitude
63	1F	SubCarrier (4 LSBs)
64	7C	SubCarrier
65	F0	SubCarrier
66	21	SubCarrier (4 MSBs)
67	67	Closed Caption – Odd Field – First Byte
68	68	Closed Caption – Odd Field – Second Byte
69	69	Closed Caption – Even Field – First Byte
6A	6A	Closed Caption – Even Field – Second Byte
6B	11	Port Select – Closed Caption Line Position
6C	6D	RCV Port Control (Slave Mode Selected)
6D	07	RCM-CC Mode
6E	9D	H Trigger (LSBs)
6F	06	H Trigger (MSBs)
70	C4	SubCarrier Reset Mode – V Trigger

## SAA7188A programming example

SUB ADDR	DATA	FUNCTION
71	6C	Begin MP Request
72	00	End MP Request
73	00	MP Request (MSBs)
74	00	NULL
75	00	NULL
76	00	NULL
77	00	Begin RCV2 Out
78	00	End RCV2 Out
79	00	RCV2 Out (MSBs)
7A	0C	Field Length
7B	12	First Active Line
7C	03	Last Active Line
7D	22	Field Control (MSBs)

Encoder in SLAVE mode (RCV1, RCV2 and LLC are INPUT).  
 RCV1 is reset with Field ID (low for Field 1, high for Field 2).  
 RCV2 is reset with HREF (low during video blanking period).

SubCarrier provides the correct 4 field sequence.

Video into MP Port, NTSC (US standard-7.5 IRE setup).

OSD programmed for 100/75 color bars.

SAA7188A driven from a Tektronix TSG422 generator (CCIR656 format).

# Digital multistandard colour decoder, square pixel (DMSD-SQP)

## SAA7191B

### 1. FEATURES

- Separate 8-bit luminance (Y or CVBS) and 8-bit chrominance inputs (CVBS or C) from CVBS, Y/C, S-Video (S-VHS or Hi8) sources
- Luminance and chrominance signal processing for standards PAL-B/G, NTSC-M, SECAM
- Horizontal and vertical sync detection for all standards
- Real-time control output RTCO to be used for frequency-locked digital video encoder (SAA7199B). RTCO contains serialized information about actual clock frequency, subcarrier frequency and PAL/SECAM sequence.
- Controls via the I<sup>2</sup>C-bus
- User programmable aperture correction (horizontal peaking)
- Compatible with memory-based features (line-locked clock)
- Cross-colour reduction by chrominance comb-filtering (NTSC) or by special cross colour cancellation (SECAM)
- 8-bit quantization of input signals
- 768/640 active samples per line equals 50/60 Hz (SQP)
- The YUV bus supports data rates of 780 x f<sub>H</sub> equal to 12.2727 MHz for 60 Hz (NTSC-M) and 944 x f<sub>H</sub> equal to 14.75 MHz for 50 Hz (PAL-B/G, SECAM) in 4 : 1 : 1 or 4 : 2 : 2 formats (via the I<sup>2</sup>C-bus)
- One crystal oscillator of 26.8 MHz

### 2. GENERAL DESCRIPTION

The SAA7191B is a digital multistandard colour decoder suitable for 8-bit CVBS input signals or for 8-bit luminance and 8-bit chrominance input signals (Y/C).

The SAA7191B is down-compatible with SAA7191. The SAA7191B has additional outputs RTCO, GPSW0 and ODD. These new outputs are in high-impedance state when NFEN-bit = 0.

### 3. QUICK REFERENCE DATA

SYMBOL	PARAMETER	MIN.	TYP.	MAX.	UNIT
V <sub>DD</sub>	positive supply voltage (pins 5, 18, 28, 37 and 52)	4.5	5	5.5	V
I <sub>DD</sub>	total supply current (pins 5, 18, 28, 37 and 52)	-	100	250	mA
V <sub>IL</sub>	input levels	TTL-compatible			
V <sub>OL</sub>	output levels	TTL-compatible			
T <sub>amb</sub>	operating ambient temperature	0	-	70	°C

### 4. ORDERING INFORMATION

EXTENDED TYPE NUMBER	PACKAGE			
	PINS	PIN POSITION	MATERIAL	CODE
SAA7191B	68	PLCC	plastic	SOT188

Digital multistandard colour decoder,  
square pixel (DMSD-SQP)

SAA7191B

5. BLOCK DIAGRAM

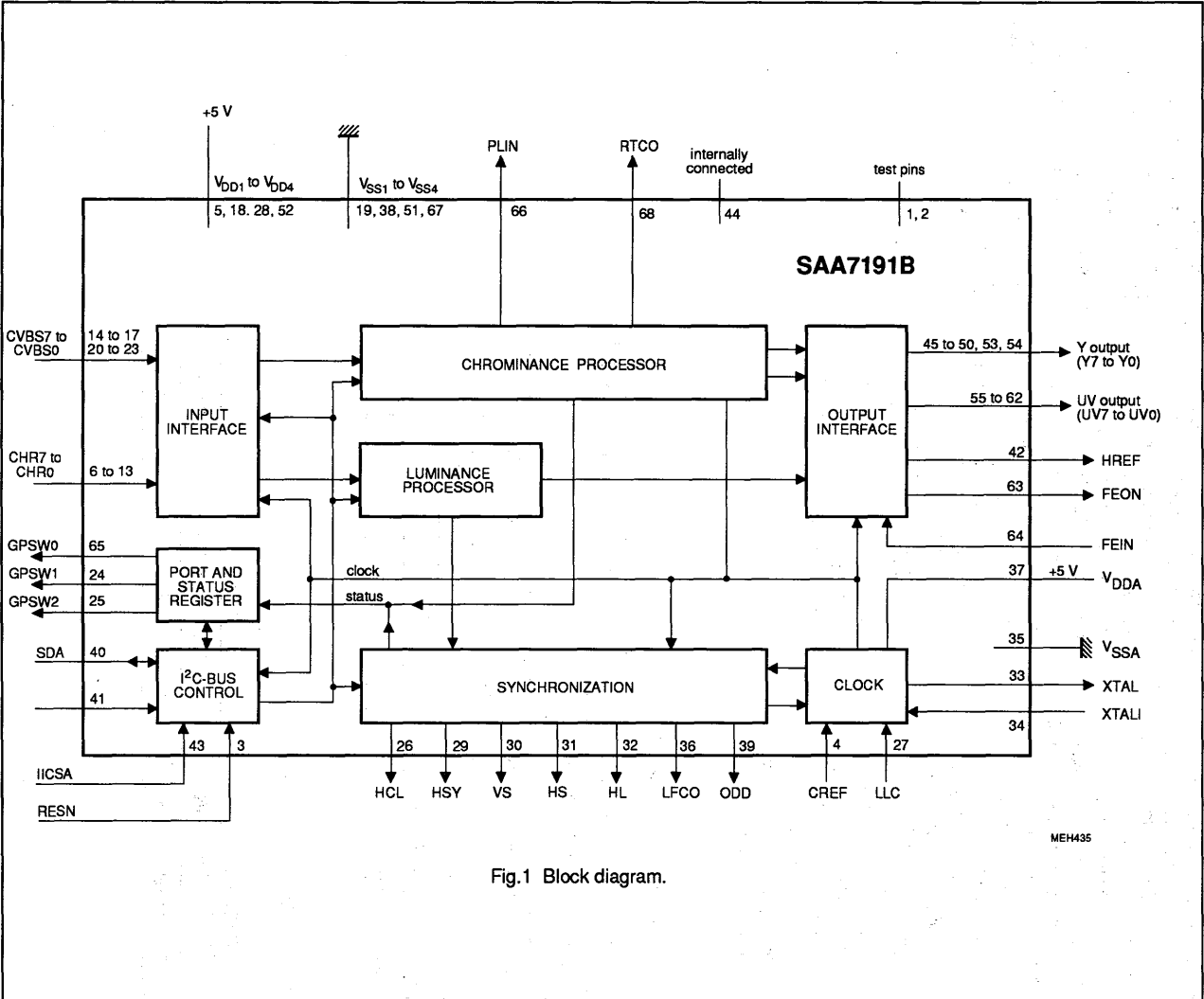

Fig.1 Block diagram.



# Digital multistandard colour decoder, square pixel (DMSD-SQP)

SAA7191B

## 6. PINNING

SYMBOL	PIN	DESCRIPTION
SP	1	connected to ground (shift pin for testing)
AP	2	connected to ground (action pin for testing)
RESN	3	reset, active LOW
CREF	4	clock reference, sync from external to ensure in-phase signals on the YUV-bus
V <sub>DD1</sub>	5	+5 V supply input 1
CHR0	6	chrominance input data bits CHR7 to CHR0 from a Y/C (VHS, Hi8) source in two's complement format
CHR1	7	
CHR2	8	
CHR3	9	
CHR4	10	
CHR5	11	
CHR6	12	
CHR7	13	
CVBS0	14	luminance respectively CVBS lower input data bits CVBS3 to CVBS0 (CVBS with luminance, chrominance and all sync information in two's complement format)
CVBS1	15	
CVBS2	16	
CVBS3	17	
V <sub>DD2</sub>	18	+5 V supply input 2
V <sub>SS1</sub>	19	ground 1 (0 V)
CVBS4	20	luminance respectively CVBS upper input data bits CVBS7 to CVBS4 (CVBS with luminance, chrominance and all sync information in two's complement format)
CVBS5	21	
CVBS6	22	
CVBS7	23	
GPSW1	24	Port 1 output for general purpose (programmable)
GPSW2	25	Port 2 output for general purpose (programmable)
HCL	26	black level clamp pulse (programmable), e.g. for TDA8708 (ADC)
LLC	27	line-locked clock input signal (29.5 MHz for 50 Hz system; 24.5454 MHz for 60 Hz system)
V <sub>DD3</sub>	28	+5 V supply input 3
HSY	29	horizontal sync indicator output signal (programmable), e.g. for TDA8708 (ADC)
VS	30	vertical sync output signal
HS	31	horizontal sync output signal (programmable)
HL	32	horizontal lock flag, HIGH = PLL locked
XTAL	33	26.8 MHz clock output
XTALI	34	26.8 MHz connection for crystal or external oscillator (TTL compatible squarewave)

**Digital multistandard colour decoder,  
square pixel (DMSD-SQP)**
**SAA7191B**

SYMBOL	PIN	DESCRIPTION
V <sub>SSA</sub>	35	analog ground
LFCO	36	line frequency control output signal, multiple of horizontal frequency (7.375 MHz/6.136363 MHz)
V <sub>DDA</sub>	37	+5 V supply input for analog part
V <sub>SS2</sub>	38	ground 2 (0 V)
ODD	39	odd/even field identification output (odd = HIGH); active only at NFEN-bit = 1
SDA	40	I <sup>2</sup> C-bus data line
SCL	41	I <sup>2</sup> C-bus clock line
HREF	42	horizontal reference output for valid YUV data (for active line 768Y or 640Y samples long)
IICSA	43	set module address input (LOW = 1000 101X; HIGH = 1000 111X)
i.c.	44	internally connected
Y7	45	Y signal output bits Y7 to Y2 (luminance), part of the digital YUV-bus
Y6	46	
Y5	47	
Y4	48	
Y3	49	
Y2	50	
V <sub>SS3</sub>	51	ground 3 (0 V)
V <sub>DD4</sub>	52	+5 V supply input 4
Y1	53	Y signal output bits Y1 to Y0 (luminance), part of the digital YUV-bus
Y0	54	
UV7	55	UV signal output bits UV7 to UV0 (colour-difference), part of the digital YUV-bus
UV6	56	
UV5	57	
UV4	58	
UV3	59	
UV2	60	
UV1	61	
UV0	62	
FEON	63	output active flag (active LOW when Y and UV data in high-impedance state)
FEIN	64	fast enable input (active LOW to control fast switching due to YUV data)
GPSW0	65	Port 0 output for general purpose (programmable); active only at NFEN-bit = 1
PLIN	66	PAL flag (active LOW at inverted line); SECAM flag (LOW equals DR, HIGH equals DB line)
V <sub>SS4</sub>	67	ground 4 (0 V)
RTCO	68	real-time control output active at NFEN-bit = 1; Fig.7



Digital multistandard colour decoder,  
square pixel (DMSD-SQP)

SAA7191B

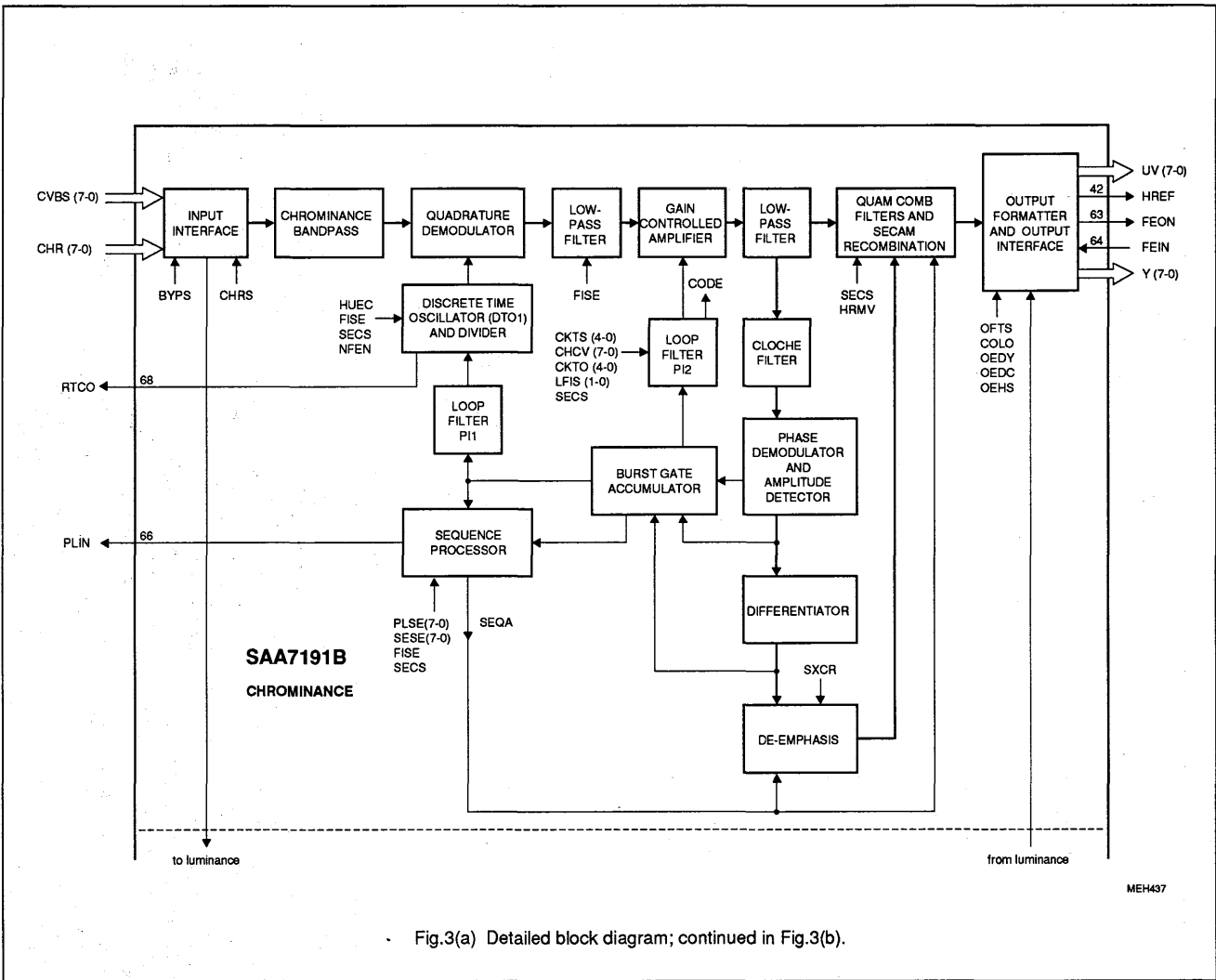

Fig.3(a) Detailed block diagram; continued in Fig.3(b).

Digital multistandard colour decoder,  
square pixel (DMSD-SQP)

SAA7191B

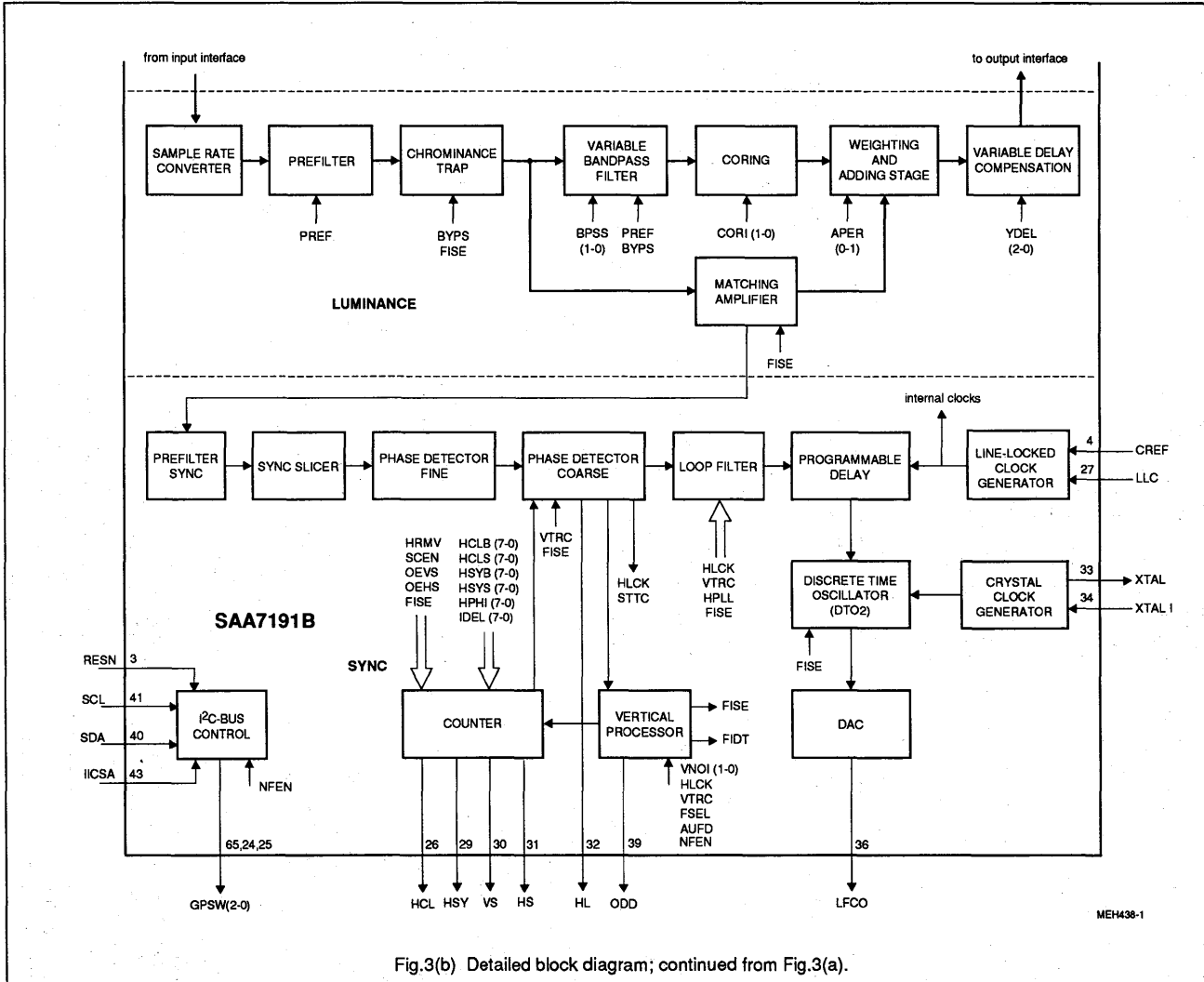

Fig.3(b) Detailed block diagram; continued from Fig.3(a).

# Digital multistandard colour decoder, square pixel (DMSD-SQP)

SAA7191B

## Luminance processor

The luminance input signal, a digital CVBS format or an 8-bit luminance format (S-VHS, Hi8), is fed through a sample rate converter to reduce the data rate to 14.75 MHz for PAL and SECAM (12.2727 MHz for NTSC), Fig.3(b).

Sample rate is converted by means of a switchable pre-filter. High frequency components are emphasized to compensate for loss in the following chrominance trap filter. This chrominance trap filter ( $f_o = 4.43$  MHz or  $f_o = 3.58$  MHz centre frequency selectable) eliminates most of the colour carrier signal, therefore, it must be by-passed for S-Video (S-VHS and Hi8) signals.

The high frequency components of the luminance signal can be "peaked" (control for sharpness improvement via the I<sup>2</sup>C-bus) in two bandpass filters with selectable transfer characteristic.

A coring circuit with selectable characteristic improves the signal once more, this signal is then added to the original ("unpeaked") signal. A switchable amplifier achieves a common DC amplification, because the DC gains are different in both chrominance trap modes.

The improved luminance signal is fed to the variable delay compensation.

## Processing delay

The delay from input to output is 220 LLC cycles if YDEL is set to 0. The processing delay will be influenced in future enhancements.

## Synchronization

The luminance output signal is fed to the synchronization stage. Its bandwidth is reduced to 1 MHz in a low-pass filter. The sync pulses are sliced and fed to the phase detectors to be compared with the sub-divided clock frequency.

The resulting output signal is applied to the loop filter to accumulate all phase deviations. Adjustable output

signals (e. g. HCL and HSY) are generated according to peripheral requirements (TDA8708A, TDA8709A). The output signals HS, VS and PLIN are locked to the timing reference signal HREF (Figures 6 and 7).

There is no absolute timing reference guaranteed between the input signal and the HREF signal as further improvements to the circuit may change the total processing delay. It is therefore not recommended to use them for applications, which ask for absolute timing accuracy to the input signals.

The loop filter signal drives an oscillator to generate the line frequency control output signal LFCO.

**Table 1** Clock frequencies in MHz for 50/60 Hz systems

CLOCK	50 Hz	60 Hz
LLC	29.5	24.545454
LLC2	14.75	12.272727
LLC4	7.375	6.136136
LLC8	3.6875	3.068181

## Line locked clock frequency

LFCO is required in an external PLL (SAA7197) to generate the line locked clock frequency.

## YUV-bus, digital outputs

The 16-bit YUV-bus transfers digital data from the output interfaces to a feature box, or to the digital-to-analog converter (DAC). Outputs are controlled via the I<sup>2</sup>C-bus in normal selections, or they are controlled by output enable chain (FEIN on pin 64, Fig.4).

The YUV-bus data rate equals LLC2 in Table 1. Timing is achieved by marking each second positive rising edge of the clock LLC in conjunction with CREF (clock reference).

YUV-bus formats 4:2:2 and 4:1:1

The output signals Y7 to Y0 are the bits of the digital luminance signal. The output signals UV7 to UV0 are the bits of the multiplexed colour-difference signals (B-Y) and (R-Y). The frame in the following tables is the time, required to transfer a full set of samples. In case of 4:2:2 format two luminance samples are transmitted in comparison to one U and one V sample within one frame.

**Table 2** 4:2:2 format  
(768 pixels per line for 50 Hz system;  
640 pixels per line for 60 Hz system)

OUTPUT	PIXEL BYTE SEQUENCE					
Y0 (LSB)	Y0	Y0	Y0	Y0	Y0	Y0
Y1	Y1	Y1	Y1	Y1	Y1	Y1
Y2	Y2	Y2	Y2	Y2	Y2	Y2
Y3	Y3	Y3	Y3	Y3	Y3	Y3
Y4	Y4	Y4	Y4	Y4	Y4	Y4
Y5	Y5	Y5	Y5	Y5	Y5	Y5
Y6	Y6	Y6	Y6	Y6	Y6	Y6
Y7 (MSB)	Y7	Y7	Y7	Y7	Y7	Y7
UV0 (LSB)	U0	V0	U0	V0	U0	V0
UV1	U1	V1	U1	V1	U1	V1
UV2	U2	V2	U2	V2	U2	V2
UV3	U3	V3	U3	V3	U3	V3
UV4	U4	V4	U4	V4	U4	V4
UV5	U5	V5	U5	V5	U5	V5
UV6	U6	V6	U6	V6	U6	V6
UV7(MSB)	U7	V7	U7	V7	U7	V7
Y frame	0	1	2	3	4	5
UV frame	0		2		4	

## Notes to Table 2

- Data rate: LLC2
- Sample frequency:  
Y LLC2  
U LLC4  
V LLC4

The quoted frequencies are valid on the YUV-bus. The time frames are controlled by the HREF signal.

# Digital multistandard colour decoder, square pixel (DMSD-SQP)

SAA7191B

**Table 3** 4 : 1 : 1 format (768 pixels per line for 50 Hz system and 640 pixels per line for 60 Hz system)

OUTPUT	PIXEL BYTE SEQUENCE							
	Y0	Y0	Y0	Y0	Y0	Y0	Y0	Y0
Y0 (LSB)	Y0	Y0	Y0	Y0	Y0	Y0	Y0	Y0
Y1	Y1	Y1	Y1	Y1	Y1	Y1	Y1	Y1
Y2	Y2	Y2	Y2	Y2	Y2	Y2	Y2	Y2
Y3	Y3	Y3	Y3	Y3	Y3	Y3	Y3	Y3
Y4	Y4	Y4	Y4	Y4	Y4	Y4	Y4	Y4
Y5	Y5	Y5	Y5	Y5	Y5	Y5	Y5	Y5
Y6	Y6	Y6	Y6	Y6	Y6	Y6	Y6	Y6
Y7 (MSB)	Y7	Y7	Y7	Y7	Y7	Y7	Y7	Y7
UV0 (LSB)	0	0	0	0	0	0	0	0
UV1	0	0	0	0	0	0	0	0
UV2	0	0	0	0	0	0	0	0
UV3	0	0	0	0	0	0	0	0
UV4	V6	V4	V2	V0	V6	V4	V2	V0
UV5	V7	V5	V3	V1	V7	V5	V3	V1
UV6	U6	U4	U2	U0	U6	U4	U2	U0
UV7 (MSB)	U7	U5	U3	U1	U7	U5	U3	U1
Y frame	0	1	2	3	4	5	6	7
UV frame	0			4				

Fast enable is achieved by setting input FEIN to LOW. This signal is used to control fast switching on the digital YUV-bus. HIGH on this pin forces the Y and U/V outputs to a high-impedance state. The signal FEON is LOW when the Y and U/V outputs are in this high-impedance state (Fig.4).

The quoted frequencies are valid on the YUV-bus. The time frames are controlled by the HREF signal.

### Notes to Table 3

Data rate:		LLC2
sample frequency:	Y	LLC2
	U	LLC8
	V	LLC8

**Table 4** Digital output control

OEDY	OEDC	FEIN	Y(7:0)	UV(7:0)	FEON
X	X	0	active	active	1
0	0	1	Z	Z	0
0	1	1	Z	active	1
1	C	1	active	Z	1
1	1	X	active	active	1

Digital multistandard colour decoder,  
square pixel (DMSD-SQP)

SAA7191B

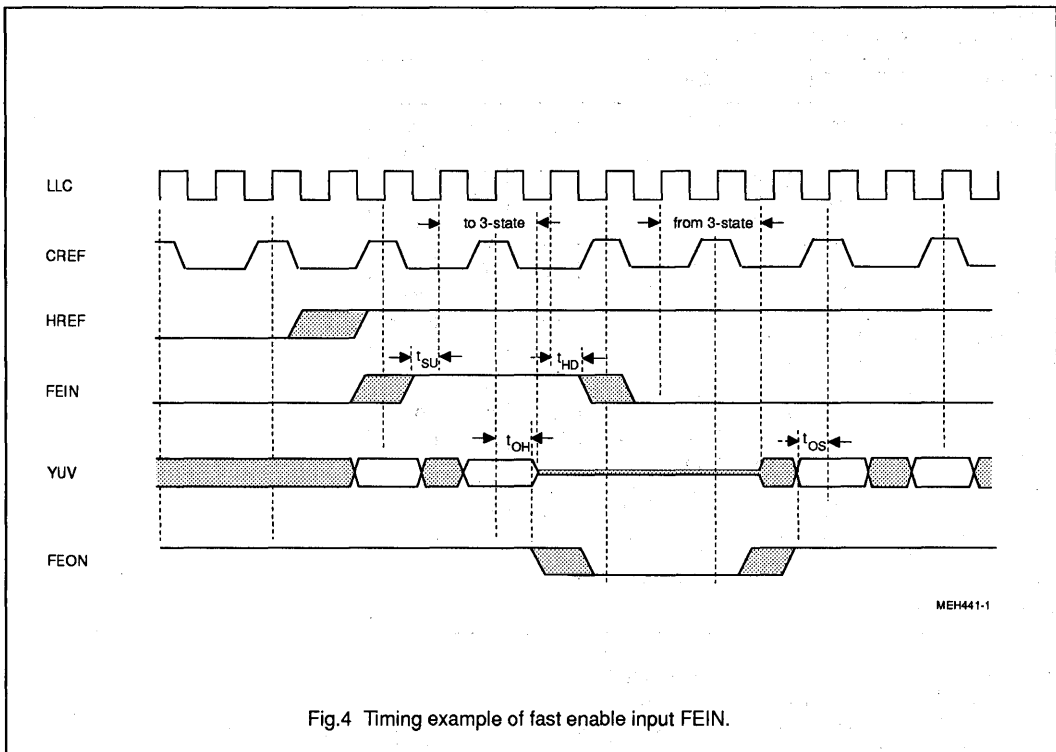

Fig.4 Timing example of fast enable input FEIN.



Digital multistandard colour decoder,  
square pixel (DMSD-SQP)

SAA7191B

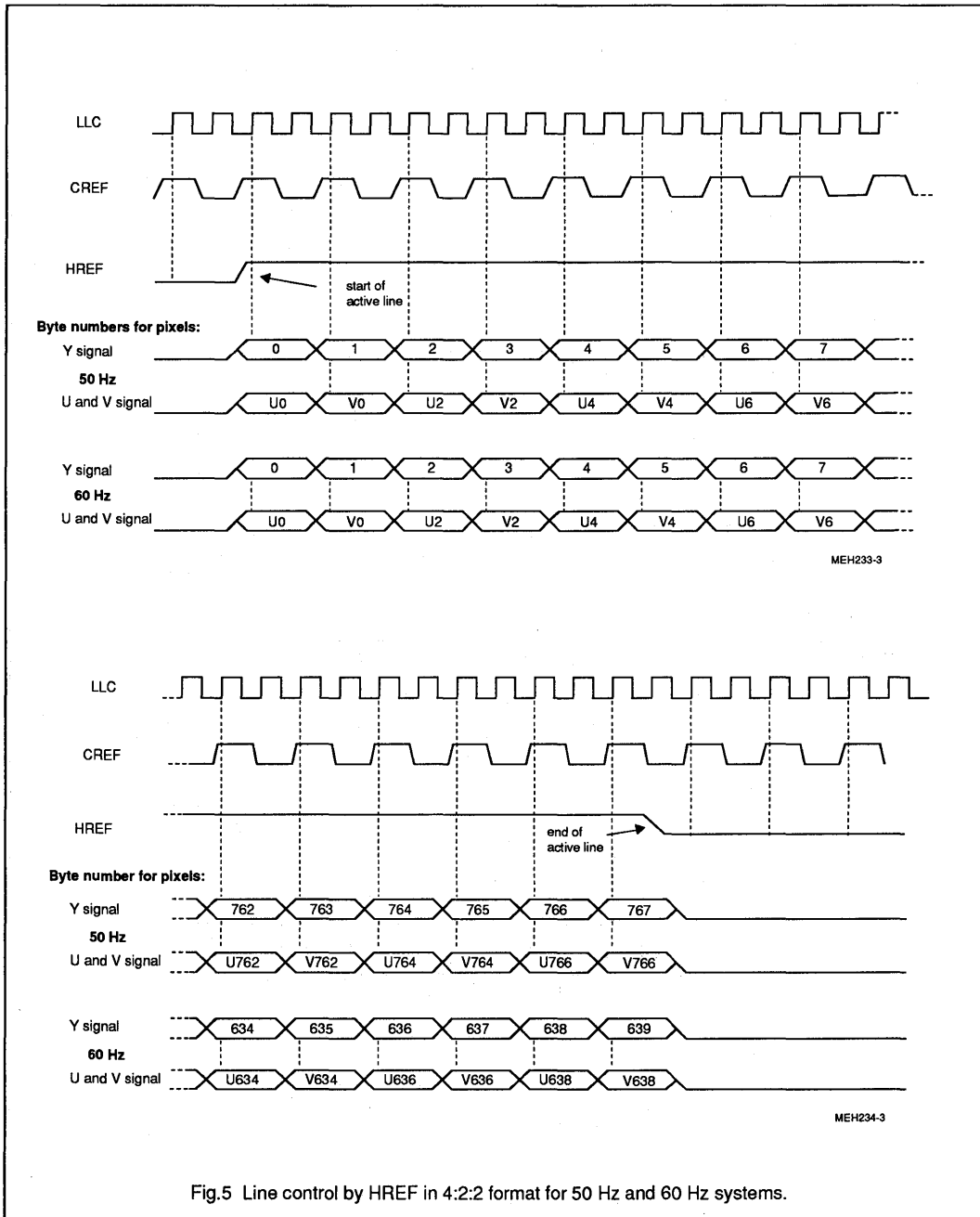

Fig.5 Line control by HREF in 4:2:2 format for 50 Hz and 60 Hz systems.

# Digital multistandard colour decoder, square pixel (DMSD-SQP)

SAA7191B

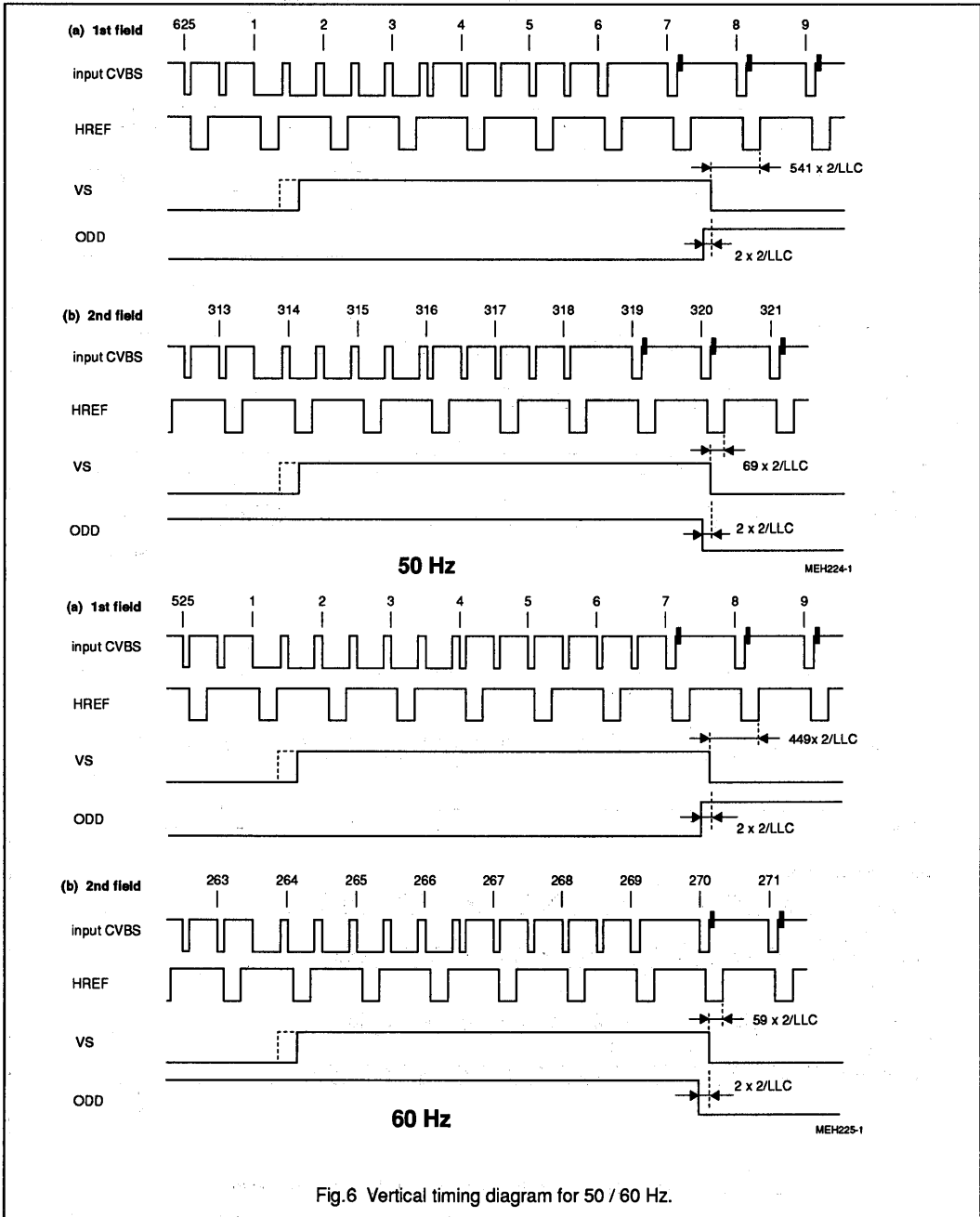

Fig.6 Vertical timing diagram for 50 / 60 Hz.

Digital multistandard colour decoder,  
square pixel (DMSD-SQP)

SAA7191B

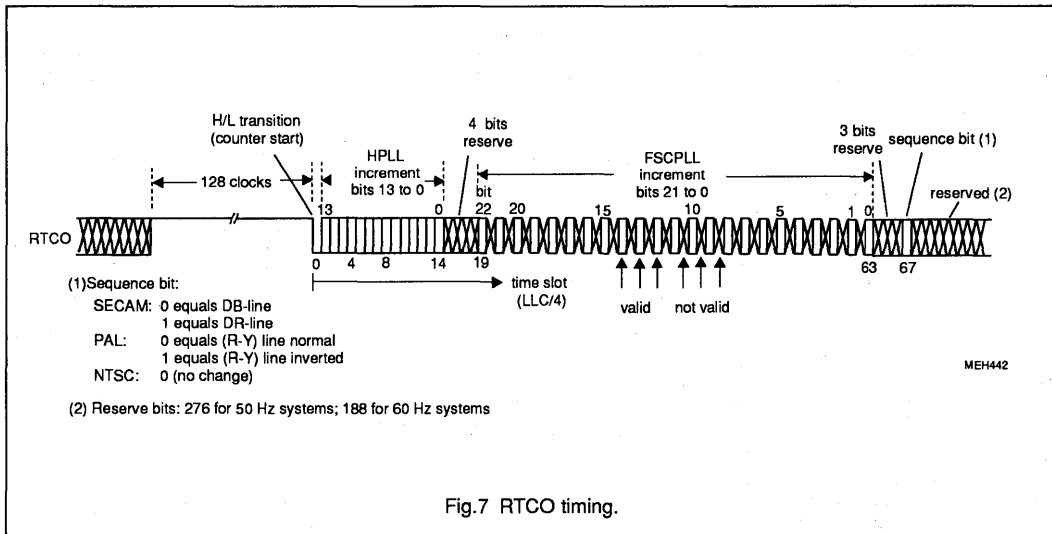

Fig.7 RTCO timing.

8. LIMITING VALUES

In accordance with the Absolute Maximum Rating System (IEC 134); ground pins 19, 35, 38, 51 and 67 as well as supply pins 5, 18, 28, 37 and 52 connected together.

SYMBOL	PARAMETER	MIN.	MAX.	UNIT
V <sub>DD</sub>	supply voltage (pins 5, 18, 28, 37, 52)	-0.5	7.0	V
V <sub>diff GND</sub>	difference voltage V <sub>SS A</sub> - V <sub>SS</sub> (1 to 4)	-	±100	mV
V <sub>I</sub>	voltage on all inputs	-0.5	V <sub>DD</sub> +0.5	V
V <sub>O</sub>	voltage on all outputs (I <sub>O max</sub> = 20 mA)	-0.5	V <sub>DD</sub> +0.5	V
P <sub>tot</sub>	total power dissipation	-	2.5	W
T <sub>stg</sub>	storage temperature range	-65	150	°C
T <sub>amb</sub>	operating ambient temperature range	0	70	°C
V <sub>ESD</sub>	electrostatic handling* for all pins	-	±2000	V

\* Equivalent to discharging a 100 pF capacitor through an 1.5 kΩ series resistor.

# Digital multistandard colour decoder, square pixel (DMSD-SQP)

SAA7191B

## 9. CHARACTERISTICS

$V_{DD} = 4.5$  to  $5.5$  V;  $T_{amb} = 0$  to  $70$  °C unless otherwise specified.

SYMBOL	PARAMETER	CONDITIONS	MIN.	TYP.	MAX.	UNIT
$V_{DD}$	supply voltage range (pins 5, 18, 28, 37, 52)		4.5	5	5.5	V
$I_{DD}$	total supply current (pins 5, 18, 28, 37, 52)	$V_{DD} = 5$ V; inputs LOW; outputs not connected	-	100	250	mA
<b>I<sup>2</sup>C-bus, SDA and SCL (pins 40 and 41)</b>						
$V_{IL}$	input voltage LOW		-0.5	-	1.5	V
$V_{IH}$	input voltage HIGH		3	-	$V_{DD}+0.5$	V
$I_{40,41}$	input current		-	-	$\pm 10$	$\mu$ A
$I_{ACK}$	output current on pin 40	acknowledge	3	-	-	mA
$V_{OL}$	output voltage at acknowledge	$I_{40} = 3$ mA	-	-	0.4	V
<b>Data clock and control inputs (pins 3, 4, 6 to 17, 20 to 23, 27, 34, 43 and 64), Fig.10</b>						
$V_{IL}$	LLC input voltage LOW (pin 27)		-0.5	-	0.6	V
$V_{IH}$	LLC input voltage HIGH		2.4	-	$V_{DD}+0.5$	V
$V_{IL}$	other input voltage LOW		-0.5	-	0.8	V
$V_{IH}$	other input voltage HIGH		2.0	-	$V_{DD}+0.5$	V
$I_{LI}$	input leakage current		-	-	10	$\mu$ A
$C_I$	input capacitance	data inputs; note 1 I/O high-ohmic clock inputs	-	-	8 8 10	pF pF pF
$t_{SU,DAT}$	input data set-up time	Fig.8	11	-	-	ns
$t_{HD,DAT}$	input data hold time		3	-	-	ns
<b>LFCO output (pin 36)</b>						
$V_o$	output signal (peak-to-peak value)	note 2	1.4	-	2.6	V
$V_{36}$	output voltage range		1	-	$V_{DD}$	V
<b>YUV-bus, HREF and VS outputs (pins 30, 42, 45 to 50 and pins 53 to 62) - Figures 11 and 15 to 25</b>						
$V_{OL}$	output voltage LOW	notes 1 and 2	0	-	0.6	V
$V_{OH}$	output voltage HIGH		2.4	-	$V_{DD}$	V
$C_L$	load capacitance		15	-	50	pF
<b>Control outputs (pins 24 to 26, 29, 31, 32, 39, 63, 65,66 and 68); Fig.12</b>						
$V_{OL}$	output voltage LOW	notes 1 and 2	0	-	0.6	V
$V_{OH}$	output voltage HIGH		2.4	-	$V_{DD}$	V
$C_L$	load capacitance		7.5	-	25	pF

# Digital multistandard colour decoder, square pixel (DMSD-SQP)

SAA7191B

SYMBOL	PARAMETER	CONDITIONS	MIN.	TYP.	MAX.	UNIT
<b>Timing of YUV-bus and control outputs</b>		Fig.7				
$t_{OH}$	output signal hold time	YUV, HREF, VS at $C_L = 15 \text{ pF}$	13	-	-	ns
		controls at $C_L = 7.5 \text{ pF}$	13	-	-	ns
$t_{OS}$	output set-up time	YUV, HREF, VS at $C_L = 50 \text{ pF}$ ;	14	-	-	ns
		controls at $C_L = 25 \text{ pF}$	14	-	-	ns
$t_{SZ}$	data output disable transition time	to 3-state condition	16	-	-	ns
$t_{ZS}$	data output enable transition time	from 3-state condition	14	-	-	ns
$t_{RTCO}$	RTCO timing			Fig.7		
<b>Chrominance PLL</b>						
$f_C$	catching range		$\pm 400$	-	-	Hz
<b>Crystal oscillator</b>		Fig.9				
$f_n$	nominal frequency	3rd harmonic	-	26.8	-	MHz
$\Delta f / f_n$	permissible deviation $f_n$		-	-	$\pm 50$	$10^{-6}$
	temperature deviation from $f_n$		-	-	$\pm 20$	$10^{-6}$
X1	crystal specification:					
	temperature range $T_{amb}$		0	-	70	$^{\circ}\text{C}$
	load capacitance $C_L$		8	-	-	pF
	series resonance resistance $R_S$		-	50	80	$\Omega$
	motional capacitance $C_1$		-	$1.1 \pm 20\%$	-	fF
	parallel capacitance $C_0$		-	$3.5 \pm 20\%$	-	pF
	Philips catalogue number		9922 520 30004			
<b>Line locked clock input LLC (pin 27)</b>		Fig.8				
$t_{LLC}$	cycle time	note 3	31	-	45	ns
$t_p$	duty factor	$t_{LLCH} / t_{LLC}$	40	-	60	%
$t_r$	rise time		-	-	5	ns
$t_f$	fall time		-	-	6	ns

**Notes to the characteristics**

- Data output signals are Y7 to Y0 and UV7 to UV0. All others are control output signals.
- Levels are measured with load circuit. YUV-bus, HREF and VS outputs with  $1.2 \text{ k}\Omega$  in parallel to  $50 \text{ pF}$  at  $3 \text{ V}$  (TTL load); LFCO output with  $10 \text{ k}\Omega$  in parallel to  $15 \text{ pF}$  and other outputs with  $1.2 \text{ k}\Omega$  in parallel to  $25 \text{ pF}$  at  $3 \text{ V}$  (TTL load).
- $t_{SU}$ ,  $t_{HD}$ ,  $t_{OH}$  and  $t_{OD}$  include  $t_r$  and  $t_f$ .



# Digital multistandard colour decoder, square pixel (DMSD-SQP)

SAA7191B

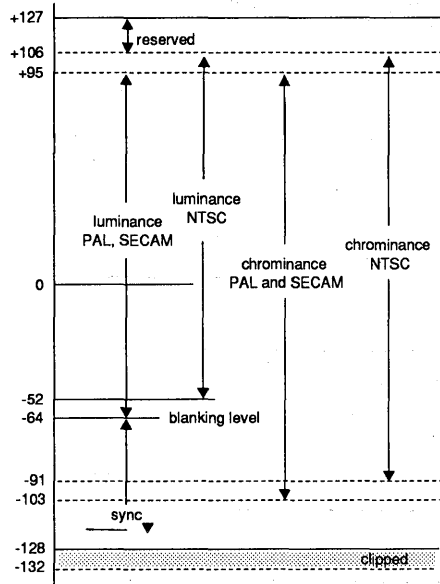

(a) CVBS7 to CVBS0 input signal range.

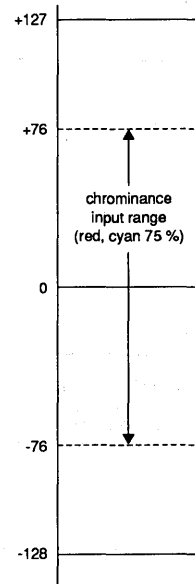

(b) CHR7 to CHR0 input signal range.

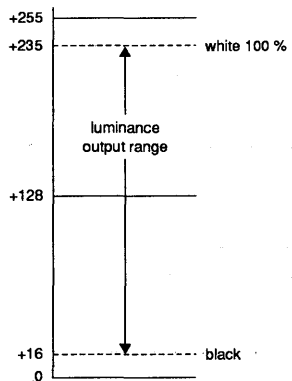

(c) Y output signal range.

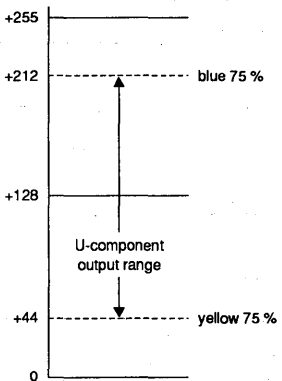

(d) U output signal range (B-Y).

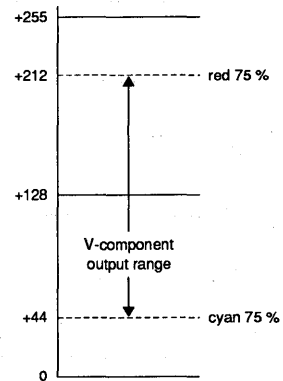

(e) V output signal range (R-Y).

- Notes: 1. All levels are related to EBU colour bar.  
2. Values in decimal at 100 % luminance and 75 % chrominance amplitude.

MEH254-2

Fig.10 Input and output signal ranges.

# Digital multistandard colour decoder, square pixel (DMSD-SQP)

SAA7191B

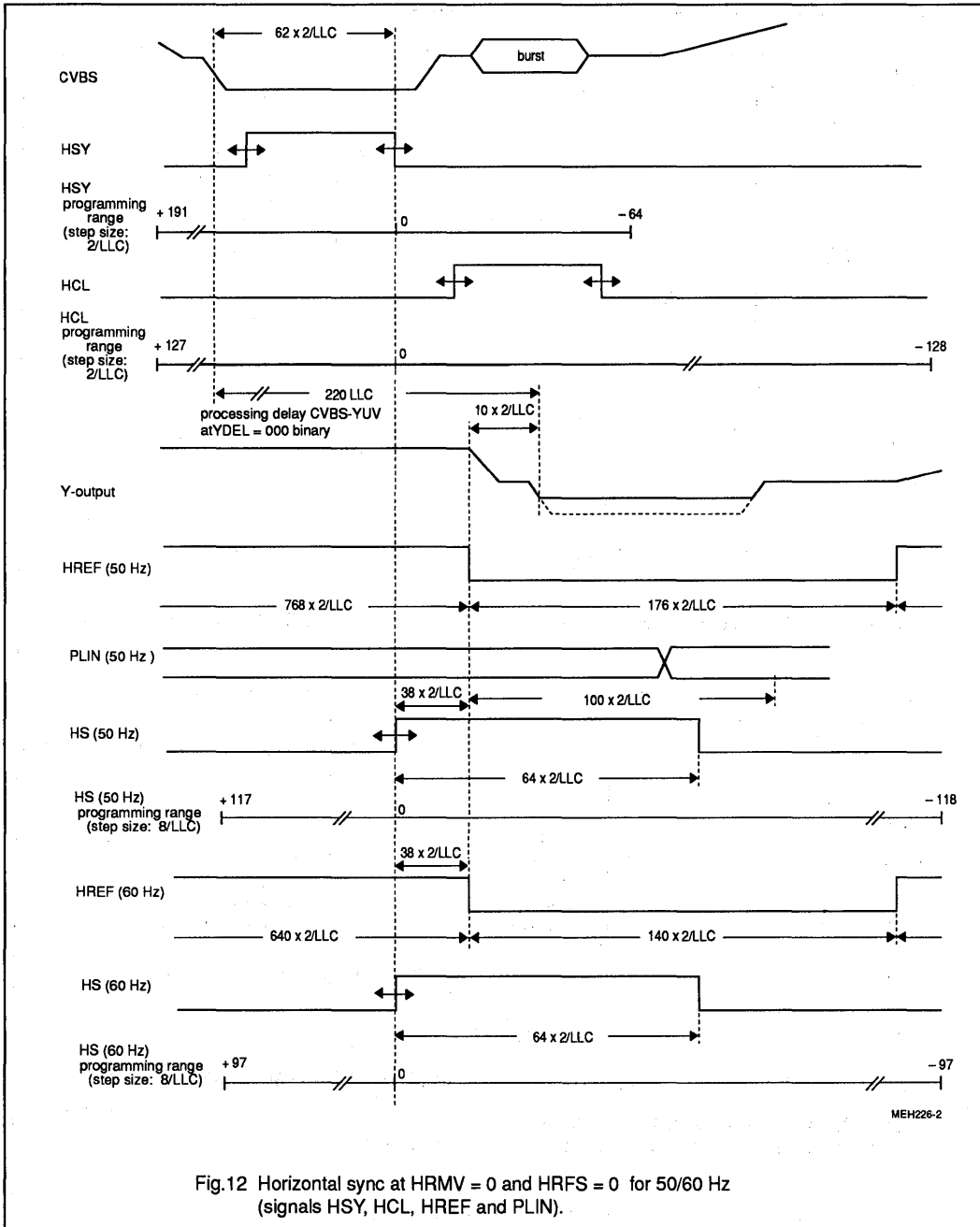

Fig.12 Horizontal sync at HRMV = 0 and HRFS = 0 for 50/60 Hz (signals HSY, HCL, HREF and PLIN).





# Digital multistandard colour decoder, square pixel (DMSD-SQP)

SAA7191B

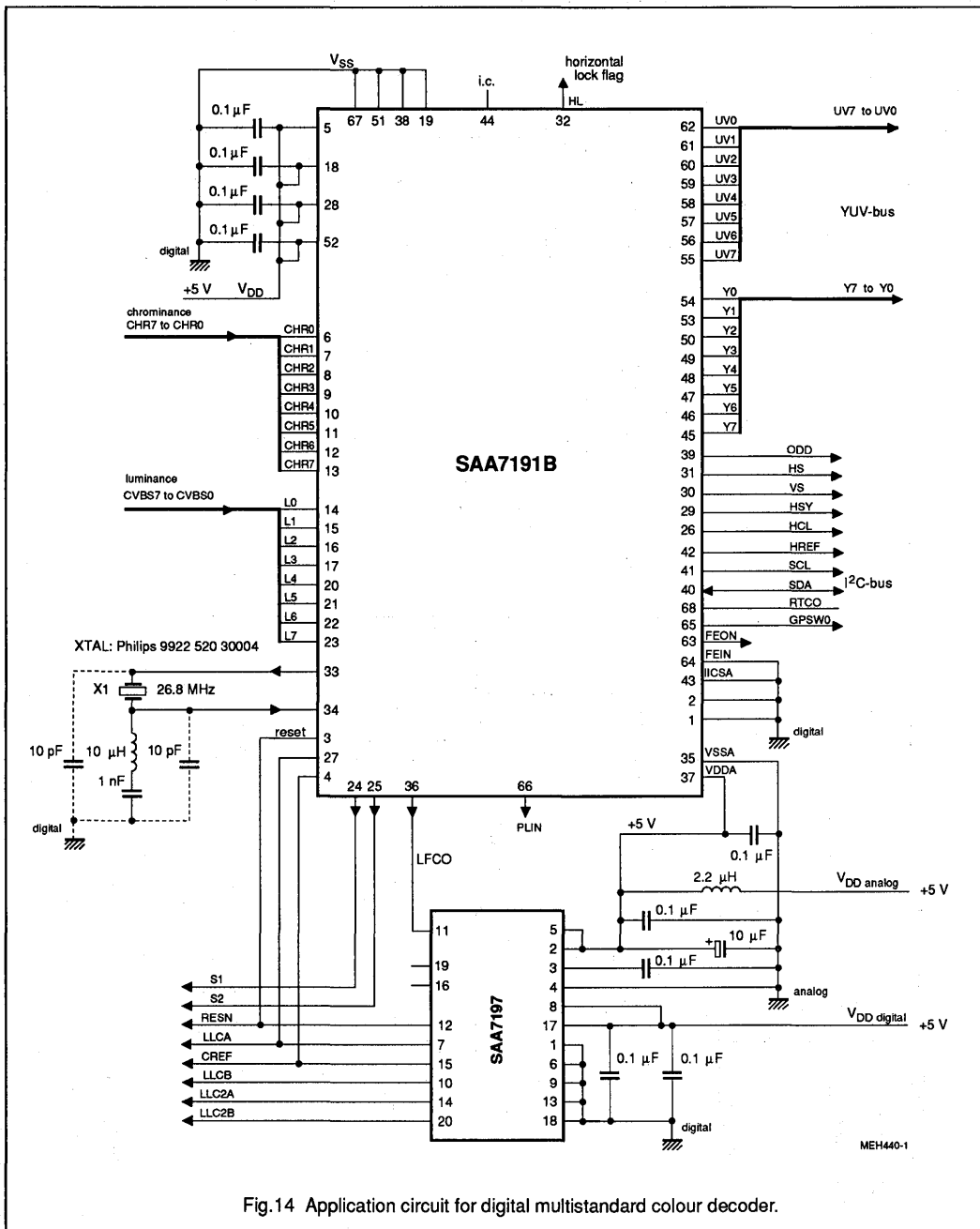

Fig.14 Application circuit for digital multistandard colour decoder.

# Digital multistandard colour decoder, square pixel (DMSD-SQP)

SAA7191B

## 10. I<sup>2</sup>C-BUS FORMAT

S	SLAVE ADDRESS	A	SUBADDRESS	A	DATA0	A	-----	DATA <sub>n</sub>	A	P
---	---------------	---	------------	---	-------	---	-------	-------------------	---	---

**S** = start condition  
**SLAVE ADDRESS** = **1000 101X** (IICSA = LOW) or **1000 111X** (IICSA = HIGH)  
**A** = acknowledge, generated by the slave  
**SUBADDRESS\*** = subaddress byte (Table 5)  
**DATA** = data byte (Table 5)  
**P** = stop condition

**X** = read/write control bit  
 X = 0, order to write (the circuit is slave receiver)  
 X = 1, order to read (the circuit is slave transmitter)

\* If more than 1 byte DATA are transmitted, then auto-increment of the subaddress is performed.

**Table 5** I<sup>2</sup>C-bus; DATA for status byte (X = 1 in address byte; 8Bh at IICSA = LOW or 8Fh at IICSA = HIGH).

FUNCTION	DATA							
	D7	D6	D5	D4	D3	D2	D1	D0
status byte	STTC	HLCK	FIDT	X	X	X	X	CODE

Function of the bits:

STTC

Horizontal time constant information for future application with logical combfilter only:

0 = TV time constant (slow);

1 = VCR time constant (fast)

HLCK

Horizontal PLL information: 0 = HPLL locked; 1 = HPLL unlocked

FIDT

Field information: 0 = 50 Hz system detected; 1 = 60 Hz system detected

CODE

Colour information: 0 = no colour detected; 1 = colour detected

# Digital multistandard colour decoder, square pixel (DMSD-SQP)

SAA7191B

**Table 6** I<sup>2</sup>C-bus; subaddress and data bytes for writing (X = 0 in address byte; 8Ah at IICSA = LOW or 8Eh at IICSA = HIGH).

FUNCTION	SUBADDRESS	DATA							
		D7	D6	D5	D4	D3	D2	D1	D0
Increment delay	00	IDEL7	IDEL6	IDEL5	IDEL4	IDEL3	IDEL2	IDEL1	IDEL0
H sync begin, 50 Hz	01	HSYB7	HSYB6	HSYB5	HSYB4	HSYB3	HSYB2	HSYB1	HSYB0
H sync stop, 50 Hz	02	HSYS7	HSYS6	HSYS5	HSYS4	HSYS3	HSYS2	HSYS1	HSYS0
H clamp begin, 50 Hz	03	HCLB7	HCLB6	HCLB5	HCLB4	HCLB3	HCLB2	HCLB1	HCLB0
H clamp stop, 50 Hz	04	HCLS7	HCLS6	HCLS5	HCLS4	HCLS3	HCLS2	HCLS1	HCLS0
H sync after PHI1, 50 Hz	05	HPHI7	HPHI6	HPHI5	HPHI4	HPHI3	HPHI2	HPHI1	HPHI0
Luminance control	06	BYPS	PREF	BPSS1	BPSS0	COR11	COR10	APER1	APER0
Hue control	07	HUEC7	HUEC6	HUEC5	HUEC4	HUEC3	HUEC2	HUEC1	HUEC0
Colour killer threshold QAM	08	CKTQ4	CKTQ3	CKTQ2	CKTQ1	CKTQ0	0	0	0
Colour-killer threshold SECAM	09	CKTS4	CKTS3	CKTS2	CKTS1	CKTS0	0	0	0
PAL switch sensitivity	0A	PLSE7	PLSE6	PLSE5	PLSE4	PLSE3	PLSE2	PLSE1	PLSE0
SECAM switch sensitivity	0B	SESE7	SESE6	SESE5	SESE4	SESE3	SESE2	SESE1	SESE0
Chroma gain control settings	0C	COLO	LFIS1	LFIS0	0	0	0	0	0
Standard/mode control	0D	VTRC	0	0	0	NFEN	HRMV	GPSW0	SECS
I/O and clock control	0E	HPLL	OEDC	OEHS	OEVS	OEDY	CHRS	GPSW2	GPSW1
Control #1	0F	AUFD	FSEL	SXCR	SCEN	OFTS	YDEL2	YDEL1	YDEL0
Control #2	10	0	0	0	0	0	HRFS	VNOI1	VNOI0
Chroma gain reference	11	CHCV7	CHCV6	CHCV5	CHCV4	CHCV3	CHCV2	CHCV1	CHCV0
Not used, is acknowledged	12	0	0	0	0	0	0	0	0
Not used, is acknowledged	13	0	0	0	0	0	0	0	0
H sync begin, 60 Hz	14	HS6B7	HS6B6	HS6B5	HS6B4	HS6B3	HS6B2	HS6B1	HS6B0
H sync stop, 60 Hz	15	HS6S7	HS6S6	HS6S5	HS6S4	HS6S3	HS6S2	HS6S1	HS6S0
H clamp begin, 60 Hz	16	HC6B7	HC6B6	HC6B5	HC6B4	HC6B3	HC6B2	HC6B1	HC6B0
H clamp stop, 60 Hz	17	HC6S7	HC6S6	HC6S5	HC6S4	HC6S3	HC6S2	HC6S1	HC6S0
H sync after PHI1, 60 Hz	18	HP6I7	HP6I6	HP6I5	HP6I4	HP6I3	HP6I2	HP6I1	HP6I0

**Note to Table 6**

- Default values of register contents to obtain a picture see Table 6.
- All unused control bits must be programmed with "0" (zero) as indicated in Table 5.

# Digital multistandard colour decoder, square pixel (DMSD-SQP)

SAA7191B

## Function of the bits of Table 5

IDEL7 to IDEL0 "00"	Increment delay time (dependent on application), step size = 4 / LLC. The delay time is selectable from $-4 / LLC$ ( $-1$ decimal multiplier) to $-1024 / LLC$ ( $-256$ decimal multiplier) equals data FF to 00 (hex). Different processing times in the chrominance channel and the clock generation could result in phase errors in the chrominance processing by transients in clock frequency. An adjustable delay (IDEL) is necessary if the processing time in the clock generation is unknown.															
HSYB7 to HSYB0 "01"	Horizontal sync begin for 50 Hz, step size = 2 / LLC. The delay time is selectable from $-382 / LLC$ ( $+191$ decimal multiplier) to $+128 / LLC$ ( $-64$ decimal multiplier) equals data BF to C0 (hex). Two's complement numbers with "hidden" sign-bit. The sign-bit is generated internally by evaluating the MSB and the MSB-1 bits.															
HSYS7 to HSYS0 "02"	Horizontal sync stop for 50 Hz, step size = 2 / LLC. The delay time is selectable from $-382 / LLC$ ( $+191$ decimal multiplier) to $+128 / LLC$ ( $-64$ decimal multiplier) equals data BF to C0 (hex). Two's complement numbers with "hidden" sign-bit. The sign-bit is generated internally by evaluating the MSB and the MSB-1 bits.															
HCLB7 to HCLB0 "03"	Horizontal clamp start for 50 Hz, step size = 2 / LLC. The delay time is selectable from $-254 / LLC$ ( $+127$ decimal multiplier) to $+256 / LLC$ ( $-128$ decimal multiplier) equals data 7F to 80 (hex).															
HCLS7 to HCLS0 "04"	Horizontal clamp stop for 50 Hz, step size = 2 / LLC. The delay time is selectable from $-254 / LLC$ ( $+127$ decimal multiplier) to $+256 / LLC$ ( $-128$ decimal multiplier) equals data 7F to 80 (hex).															
HPHI7 to HPHI0 "05"	Horizontal sync after PHI1 for 50 Hz, step size = 8 / LLC. The delay time is selectable from $-936 / LLC$ ( $+117$ decimal multiplier) to $+944 / LLC$ ( $-118$ decimal multiplier) equals data 75 to 8A (hex).															
BYPS "06"	input mode select bit: 0 = CVBS mode (chrominance trap active) 1 = S-Video mode (chrominance trap bypassed)															
PREF	use of pre-filter: 0 = pre-filter off; 1 = pre-filter on; PREF may be used if chrominance trap is active.															
BPSS1 to BPSS0	Aperture bandpass to select different characteristics with maximums ( $0.2$ to $0.3 \times LLC / 2$ ): <table border="1" style="margin-left: 20px;"> <thead> <tr> <th>BPSS1</th> <th>BPSS0</th> <th>characteristics</th> </tr> </thead> <tbody> <tr> <td>0</td> <td>0</td> <td>)</td> </tr> <tr> <td>0</td> <td>1</td> <td>)</td> </tr> <tr> <td>1</td> <td>0</td> <td>)</td> </tr> <tr> <td>1</td> <td>1</td> <td>)</td> </tr> </tbody> </table> <p style="text-align: right; margin-right: 20px;">Figures 16 to 25</p>	BPSS1	BPSS0	characteristics	0	0	)	0	1	)	1	0	)	1	1	)
BPSS1	BPSS0	characteristics														
0	0	)														
0	1	)														
1	0	)														
1	1	)														
CORI1 to CORI0 "06"	Coring range for high frequency components according to 8-bit luminance, Fig.15. <table border="1" style="margin-left: 20px;"> <thead> <tr> <th>CORI1</th> <th>CORI0</th> <th>coring</th> </tr> </thead> <tbody> <tr> <td>0</td> <td>0</td> <td>coring off</td> </tr> <tr> <td>0</td> <td>1</td> <td><math>\pm 1</math> LSB</td> </tr> <tr> <td>1</td> <td>0</td> <td><math>\pm 2</math> LSB</td> </tr> <tr> <td>1</td> <td>1</td> <td><math>\pm 3</math> LSB</td> </tr> </tbody> </table>	CORI1	CORI0	coring	0	0	coring off	0	1	$\pm 1$ LSB	1	0	$\pm 2$ LSB	1	1	$\pm 3$ LSB
CORI1	CORI0	coring														
0	0	coring off														
0	1	$\pm 1$ LSB														
1	0	$\pm 2$ LSB														
1	1	$\pm 3$ LSB														

Digital multistandard colour decoder,  
square pixel (DMSD-SQP)

SAA7191B

APER1 to "06"	APER0	Aperture bandpass filter weights high frequency components of luminance signal:	
		APER1	APER0
		factor	
		0	0
		0	1
		1	0
		1	1
		0	)
		0.25	)
		0.5	)
		1	)
		Figures 16 to 25	
HUE7 to "07"	HUE0	Hue control from +178.6° to -180.0°, equals data bytes 7F to 80 (hex); 0° equals 00.	
CKTQ4 to "08"	CKTQ0	Colour-killer threshold QAM from approximately -30 dB to -18 dB, equals data bytes F8 to 07 (hex)	
CKTS4 to "09"	CKTS0	Colour-killer threshold SECAM from approximately -30 dB to -18 dB, equals data bytes. F8 to 07 (hex)	
PLSE7 to "0A"	PLSE0	PAL switch sensitivity from LOW-to-HIGH (HIGH means immediate sequence correction), equals FF to 00 (hex), MEDIUM equals 80.	
SESE7 to "0B"	SESE0	SECAM switch sensitivity from LOW-to-HIGH (HIGH means immediate sequence correction), equals FF to 00 (hex), MEDIUM equals 80.	
COLO "0C"		Colour on bit: 0 = automatic colour-killer enabled; 1 = forced colour on.	
LFIS1 to "0C"	LFIS0	Chrominance gain control (AGC filter):	
		LFIS1	LFIS0
		loop filter time constant	
		0	0
		0	1
		1	0
		1	1
		=	slow
		=	medium
		=	fast
		=	actual gain, stored for test purposes only
VTRC "0D"		VTR/TV mode bit : 0 = TV mode (slow time constant); 1 = VTR mode (fast time constant)	
NFEN		SAA7191B-specified functions enable (RTCO, ODD and GPSW0 outputs) 0 = outputs set to high-impedance (circuit equals SAA7191); 1 = outputs active	
HRMV		HREF generation: 0 = like SAA7191; 1 = HREF is 8 x LLC2 clocks earlier	
GPSW0		General purpose switch 0: 0 = output pin 65 LOW; 1 = output pin 65 HIGH	
SECS		SECAM mode bit : 0 = other standards; 1 = SECAM	
HPLL "0E"		Horizontal clock PLL: 0 = PLL closed; 1 = PLL circuit open and horizontal frequency fixed.	
OEDC		Colour-difference output enable: 0 = data outputs UV7 to UV0 can be set to high-impedance via FEIN 1 = data outputs UV7 to UV0 active.	
OEHS		H-sync output enable (pins 31 and 42): 0 = HS and HREF outputs high-impedance 1 = HS and HREF outputs active.	
OEVS		V-sync output enable (pin 30): 0 = VS output high-impedance 1 = VS output active.	

# Digital multistandard colour decoder, square pixel (DMSD-SQP)

SAA7191B

OEDY	Luminance output enable: 0 = data outputs Y7 to Y0 can be set to high-impedance via FEIN 1 = data outputs Y7 to Y0 active.		
CHRS	S-VHS bit (chrominance from CVBS or from chrominance input): 0 = controlled by BYPS-bit (subaddress 06) 1 = chrominance from chrominance input (CHR7 to CHR0)		
GPSW2 to to "0E"	GPSW1	General purpose switches : set port output pins 24 (GPSW2) and 25 (GPSW1)	
	GPSW2	GPSW1	
	0	0	
	0	1	use is dependent on application
	1	0	
	1	1	
AUFD "0F"	Automatic field detection: 0 = field selection by FSEL-bit; 1 = automatic field detection.		
FSEL	Field select (AUFD-bit = 0): 0 = 50 Hz (625 lines); 1 = 60 Hz (525 lines)		
SXCR	SECAM cross-colour reduction: 0 = reduction off; 1 = reduction on.		
SCEN	Sync and clamping pulse enable: 0 = HCL and HSY outputs HIGH (pins 26 and 29); 1 = HCL and HSY outputs active		
OFTS	Select output format: 0 = 4 : 1 : 1 format; 1 = 4 : 2 : 2 format.		
YDEL2 to YDEL0	YDEL2	YDEL1	YDEL0
	0	0	0
	0	0	1
	0	1	0
	0	1	1
	1	0	0
	1	0	1
	1	1	0
	1	1	1
			figure
			0 x 2 / LLC
			+1 x 2 / LLC
			+2 x 2 / LLC
			+3 x 2 / LLC
			-4 x 2 / LLC
			-3 x 2 / LLC
			-2 x 2 / LLC
			-1 x 2 / LLC
			step size = 2 / LLC = 67.8 ns for 50 Hz 81.5 ns for 60 Hz
HRFS "10"	Select HREF position: 0 = normal, HREF is matched to YUV output port; 1 = HREF is matched to CVBS input port.		
VNOI1 to VNOI0	VNOI1	VNOI0	mode
	0	0	normal
	0	1	searching window
	1	0	auto-deflection
	1	1	vertical noise reduction bypassed

# Digital multistandard colour decoder, square pixel (DMSD-SQP)

SAA7191B

CHCV7 to UV	CHCV0 "11"	Chrominance gain control (nominal values) for QAM-modulated input signals, effects output amplitude (SECAM with fixed gain):																																																																								
		<table border="1"> <thead> <tr> <th>D7</th> <th>D6</th> <th>D5</th> <th>D4</th> <th>D3</th> <th>D2</th> <th>D1</th> <th>D0</th> <th>gain</th> </tr> </thead> <tbody> <tr> <td>1</td> <td>1</td> <td>1</td> <td>1</td> <td>1</td> <td>1</td> <td>1</td> <td>1</td> <td>maximum gain</td> </tr> <tr> <td>:</td> <td>:</td> <td>:</td> <td>:</td> <td>:</td> <td>:</td> <td>:</td> <td>:</td> <td>to )</td> </tr> <tr> <td>0</td> <td>1</td> <td>0</td> <td>1</td> <td>1</td> <td>0</td> <td>0</td> <td>1</td> <td>CCIR level for PAL) ) default programmed</td> </tr> <tr> <td>:</td> <td>:</td> <td>:</td> <td>:</td> <td>:</td> <td>:</td> <td>:</td> <td>:</td> <td>to ) values dependend</td> </tr> <tr> <td>0</td> <td>0</td> <td>1</td> <td>0</td> <td>1</td> <td>1</td> <td>0</td> <td>0</td> <td>CCIR level for NTSC) ) on application</td> </tr> <tr> <td>:</td> <td>:</td> <td>:</td> <td>:</td> <td>:</td> <td>:</td> <td>:</td> <td>:</td> <td>to )</td> </tr> <tr> <td>0</td> <td>0</td> <td>0</td> <td>0</td> <td>0</td> <td>0</td> <td>0</td> <td>0</td> <td>minimum gain</td> </tr> </tbody> </table>	D7	D6	D5	D4	D3	D2	D1	D0	gain	1	1	1	1	1	1	1	1	maximum gain	:	:	:	:	:	:	:	:	to )	0	1	0	1	1	0	0	1	CCIR level for PAL) ) default programmed	:	:	:	:	:	:	:	:	to ) values dependend	0	0	1	0	1	1	0	0	CCIR level for NTSC) ) on application	:	:	:	:	:	:	:	:	to )	0	0	0	0	0	0	0	0	minimum gain
D7	D6	D5	D4	D3	D2	D1	D0	gain																																																																		
1	1	1	1	1	1	1	1	maximum gain																																																																		
:	:	:	:	:	:	:	:	to )																																																																		
0	1	0	1	1	0	0	1	CCIR level for PAL) ) default programmed																																																																		
:	:	:	:	:	:	:	:	to ) values dependend																																																																		
0	0	1	0	1	1	0	0	CCIR level for NTSC) ) on application																																																																		
:	:	:	:	:	:	:	:	to )																																																																		
0	0	0	0	0	0	0	0	minimum gain																																																																		
HS6B7 to "14"	HS6B0	Horizontal sync begin for 60 Hz, step size = 2 / LLC. The delay time is selectable from -382/LLC (+191 decimal multiplier) to +128/LLC (-64 decimal multiplier) equals data BF to C0 (hex). Two's complement numbers with "hidden" sign-bit. The sign-bit is generated internally by evaluating the MSB and the MSB-1 bits.																																																																								
HS6S7 to "15"	HS6S0	Horizontal sync stop for 60 Hz, step size = 2 / LLC. The delay time is selectable from -382/LLC (+191 decimal multiplier) to +128/LLC (-64 decimal multiplier) equals data BF to C0 (hex). Two's complement numbers with "hidden" sign-bit. The sign-bit is generated internally by evaluating the MSB and the MSB-1 bits.																																																																								
HC6B7 to "16"	HC6B0	Horizontal clamp begin for 60 Hz, step size = 2 / LLC. The delay time is selectable from -254/LLC (+127 decimal multiplier) to +256/LLC (-128 decimal multiplier) equals data 7F to 80 (hex).																																																																								
HC6S7 to "17"	HC6S0	Horizontal clamp stop for 60 Hz, step size = 2 / LLC. The delay time is selectable from -254/LLC (+127 decimal multiplier) to +256/LLC (-128 decimal multiplier) equals data 7F to 80 (hex).																																																																								
HP617 to "18"	HP610	Horizontal sync after PHI1 for 60 Hz, step size = 8 / LLC. The delay time is selectable from -776 /LLC (+97 decimal multiplier) to +776 /LLC (-97 decimal multiplier) equals data 61 to 9F (hex).																																																																								

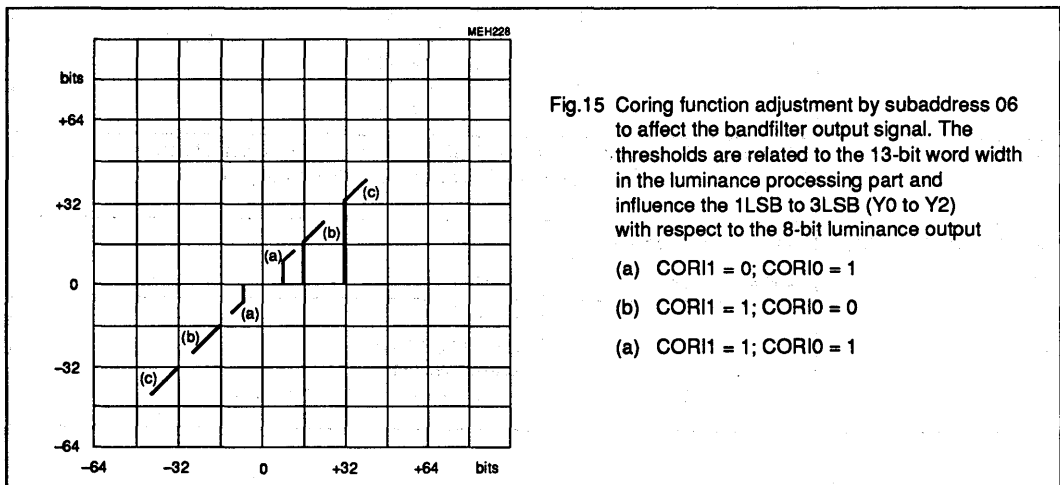



Digital multistandard colour decoder,  
square pixel (DMSD-SQP)

SAA7191B

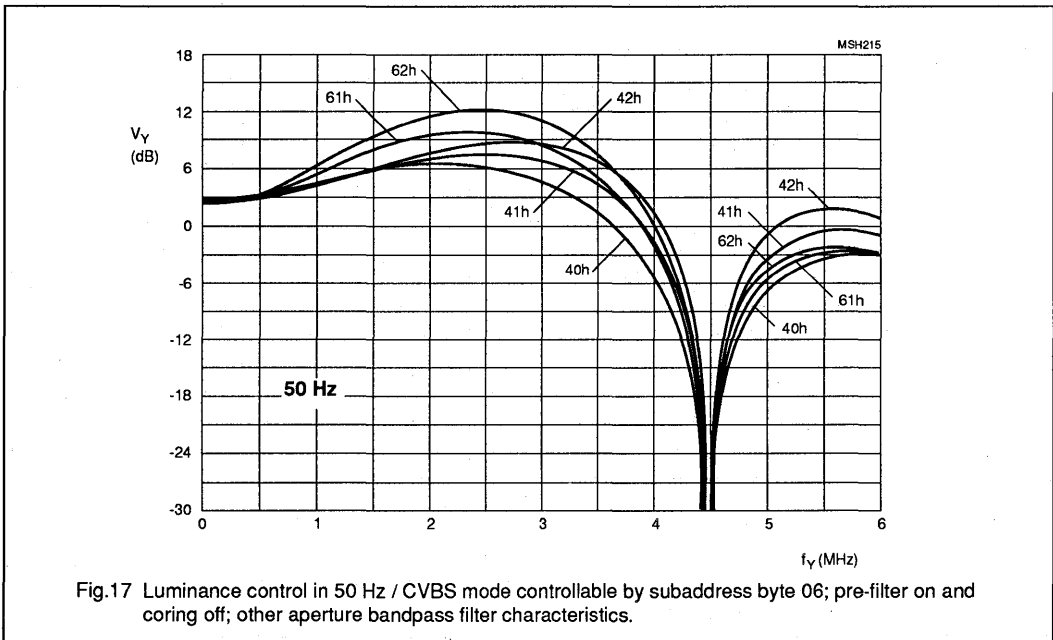
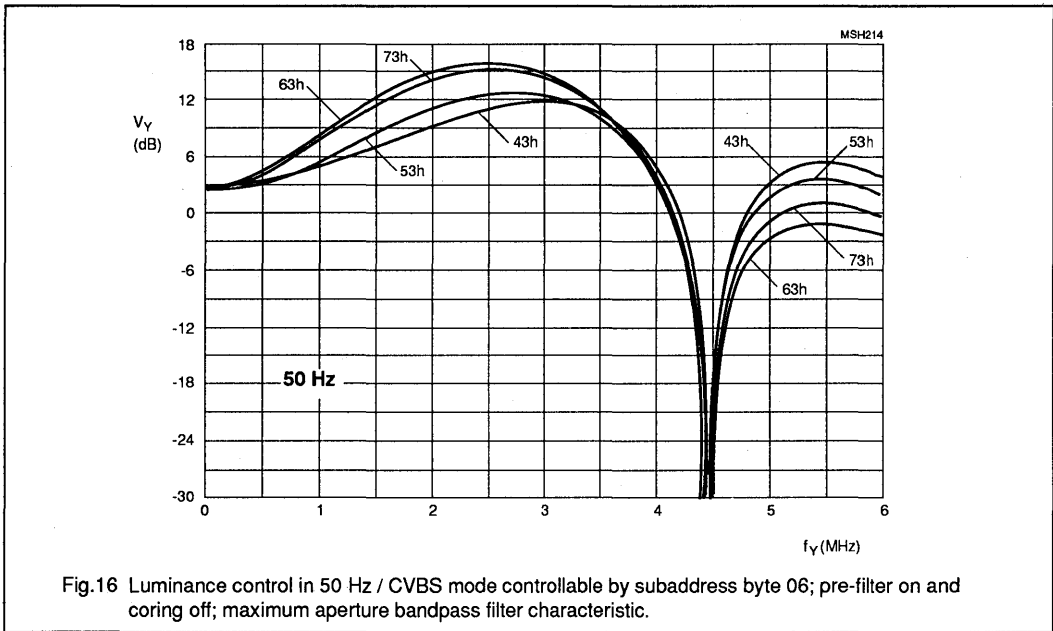

# Digital multistandard colour decoder, square pixel (DMSD-SQP)

SAA7191B

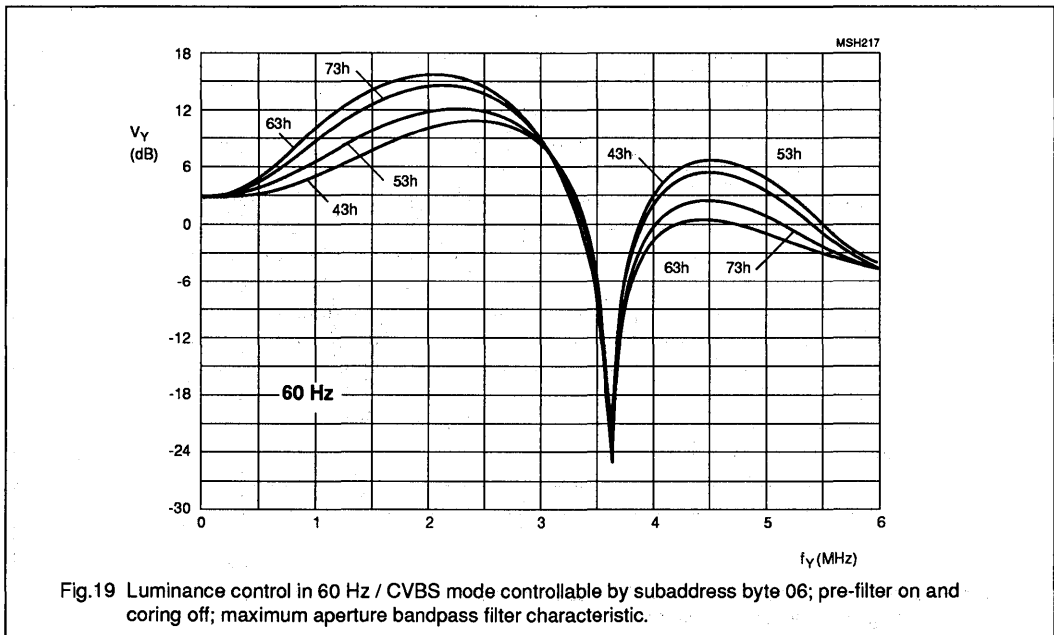
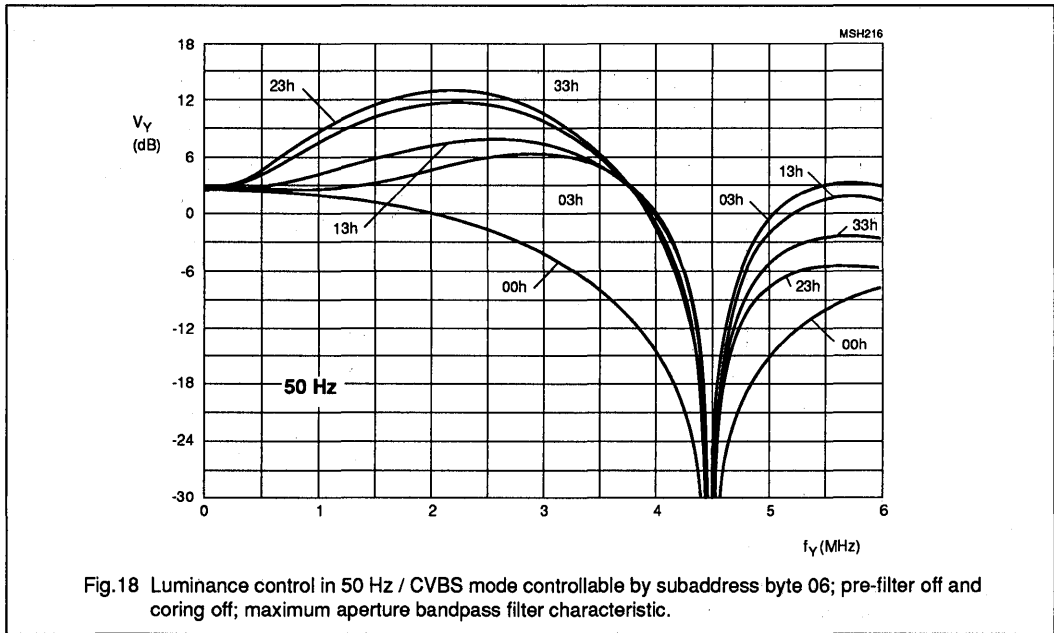

# Digital multistandard colour decoder, square pixel (DMSD-SQP)

SAA7191B

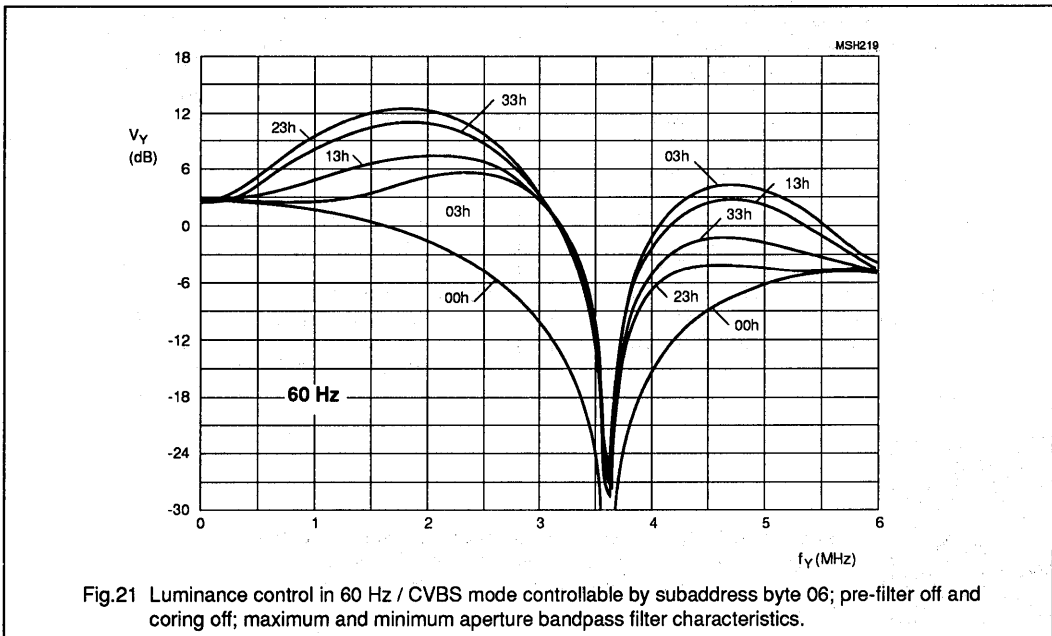
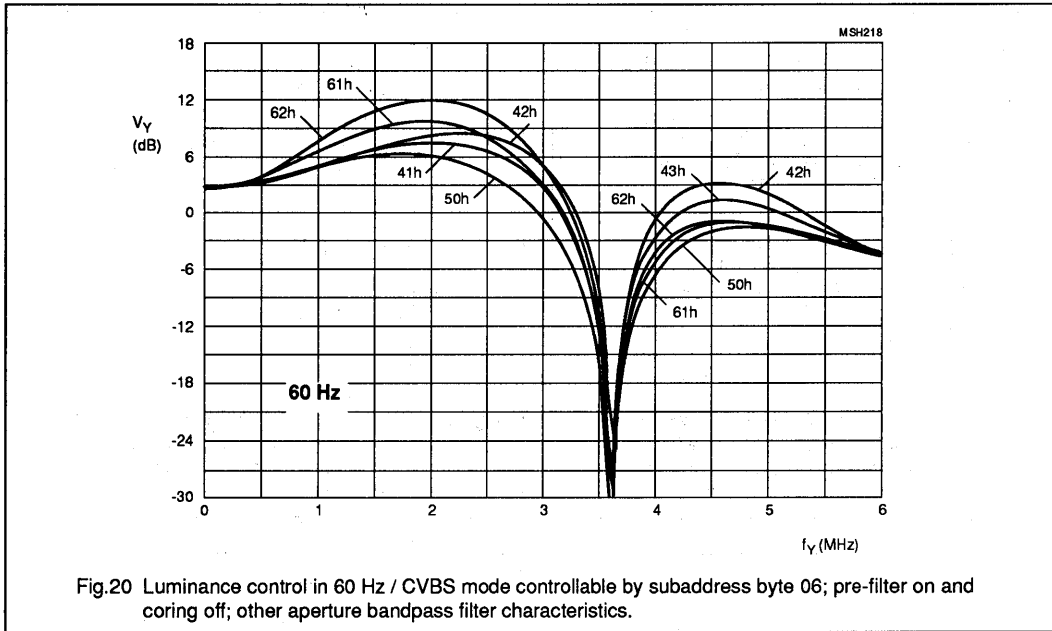

# Digital multistandard colour decoder, square pixel (DMSD-SQP)

SAA7191B

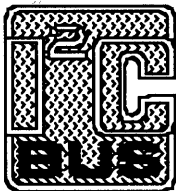
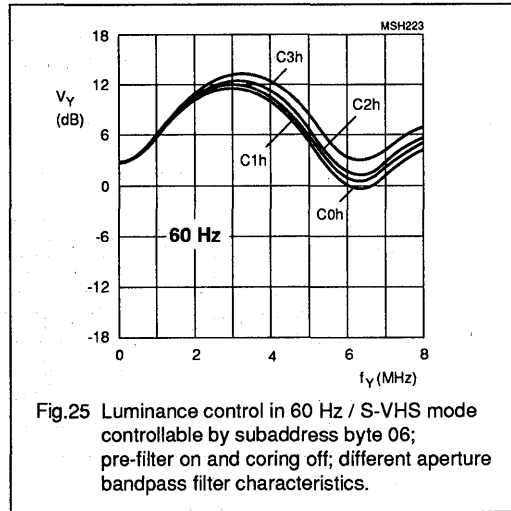
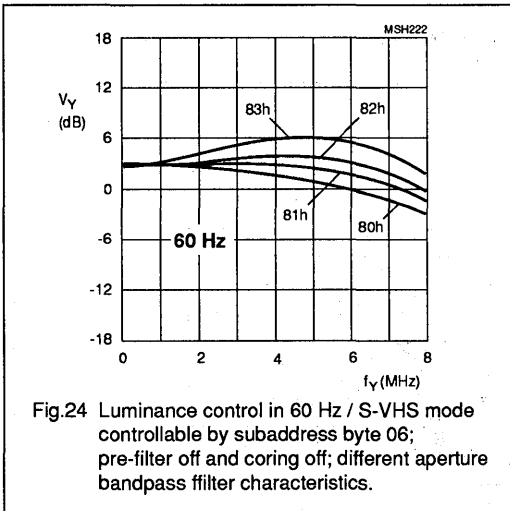
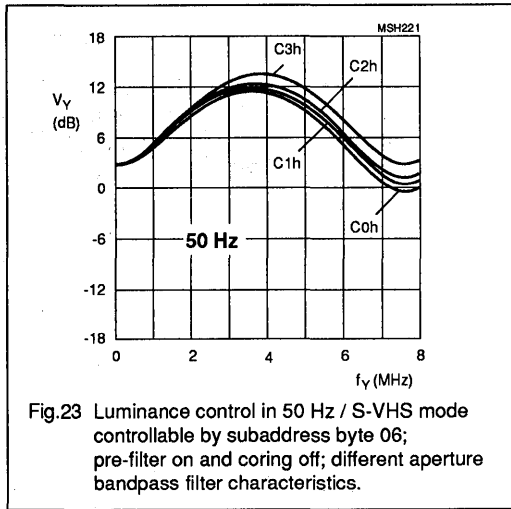
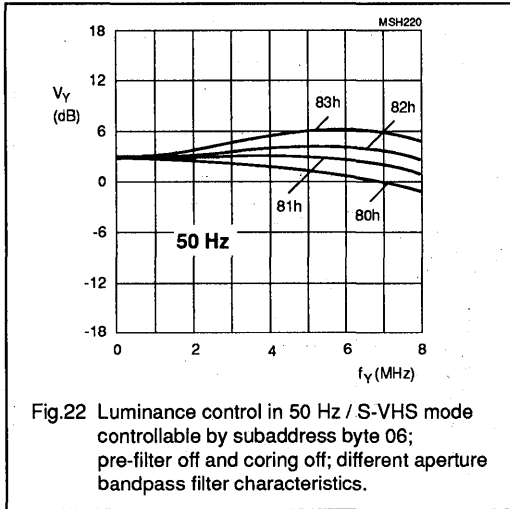

Purchase of Philips' I<sup>2</sup>C components conveys a license under the Philips' I<sup>2</sup>C patent to use the components in the I<sup>2</sup>C-system provided the system conforms to the I<sup>2</sup>C specifications defined by Philips.

# Digital multistandard colour decoder, square pixel (DMSD-SQP)

SAA7191B

**PROGRAMMING EXAMPLE**

Coefficients to set operation for application circuits Figures 13 and 14. (All numbers of the Table 6 are hex values).  
Slave address byte is 8A at pin 43 = 0 V (or 8E at pin 43 = +5 V).

**Table 7** Recommended default values

SUBADDRESS	BIT NAME	FUNCTION	VALUE (HEX)
00	IDEL(7-0)	increment delay	50
01	HSYB(7-0)	H sync beginning for 50 Hz	30
02	HSYS(7-0)	H sync stop for 50 Hz	00
03	HCLB(7-0)	H clamping beginning for 50 Hz	E8
04	HCLS(7-0)	H clamping stop for 50 Hz	B6
05	HPhi(7-0)	H sync position for 50 Hz	F4
06	BYPS, PREF, BPSS(1-0)	luminance bandwidth control: hue control (0 degree)	01 <sup>(1)</sup>
07	CORI(1-0), APER(1-0)		00
08	HUEC(7-0)		00
09	CKTQ(4-0)	colour-killer threshold QUAM	F8
0A	CKTS(4-0)	colour-killer threshold SECAM	F8
0A	PLSE(7-0)	PAL switch sensitivity	90
0B	SESE(7-0)	SECAM switch sensitivity	90
0C	COLO, LFIS(1-0)	chroma gain control settings	00
0D	VTRC, NFEN, HRMV, GPSW0 and SECS	standard/mode control	00 <sup>(2)(4)</sup> , 01 <sup>(3)(4)</sup>
0E	HPLL, OEDC, OEHS, OEVS OEDY, CHR5, GPSW(2-1)	I/O and clock control	79, 7E <sup>(5)</sup>
0F	AUFD, FSEL, SXCR, SCEN, OFTS, YDEL(2-0)	miscellaneous control #1	91 <sup>(6)</sup> , 99 <sup>(7)</sup>
10	HRFS, VNOI(1-0)	miscellaneous control #2	00
11	CHCV(7-0)	chrominance gain nominal value	2C <sup>(8)</sup> , 59 <sup>(9)</sup>
12	-	set to zero	00
13	-	set to zero	00
14	HS6B(7-0)	H sync beginning for 60 Hz	34
15	HS6S(7-0)	H sync stop for 60 Hz	0A
16	HC6B(7-0)	H clamping beginning for 60 Hz	F4
17	HC6S(7-0)	H clamping stop for 60 Hz	CE
18	HP6I(7-0)	H sync position for 60 Hz	F4

**Notes to Table 7**

- (1) dependent on application (Figures 16 to 25)
- (2) for QUAM standards
- (3) for SECAM
- (4) HPLL is in TV mode; value for VCR mode is 80 (81 for SECAM VCR mode)
- (5) for Y/C mode
- (6) 4:1:1 format
- (7) 4:2:2 format
- (8) nominal value for UV CCIR level with NTSC source
- (9) nominal value for UV CCIR level with PAL source

## Digital colour space converter

SAA7192A

## FEATURES

- Input formatter with:
  - multiplexer
  - Y-delay line
  - Cr and Cb interpolating filters
- Conversion matrix (acc. to CCIR 601)
- Video look-up tables (provide gamma correction)
- Pipeline delay line (horizontal reference signal)
- I<sup>2</sup>C-bus interface

## GENERAL DESCRIPTION

The Digital Colour Space Converter (DCSC) is a digital matrix which is used to transform 16/24-bit digital input signals, i.e. Y (luminance), Cr (colour, R-Y) and Cb (colour, B-Y), into an RGB 24-bit format in accordance with the CCIR-601 recommendations.

Accepting inputs from the different formats of the DMSD2 decoder family, the device has a constant propagation delay and a maximum data rate of 16 MHz. A matched pipeline delay line is available to permit the HREF signal to be synchronized with the video data at the output.

## QUICK REFERENCE DATA

SYMBOL	PARAMETER	MIN	MAX	UNIT
V <sub>DD</sub>	Supply voltage	-0.5	7	V
V <sub>I</sub>	input voltage	-0.5	7	V
V <sub>O</sub>	output voltage	-0.5	7	V
P <sub>tot</sub>	total power dissipation	-	1.5	W
T <sub>stg</sub>	storage temperature range	-65	+150	C
T <sub>amb</sub>	operating ambient temperature	0	+70	C

## ORDERING INFORMATION

EXTENDED TYPE NUMBER	PACKAGE			
	PINS	PIN POSITION	MATERIAL	CODE
SAA7192	68	PLCC	plastic	SOT18-8AA, AGA, CGS

Digital colour space converter

SAA7192A

BLOCK DIAGRAM

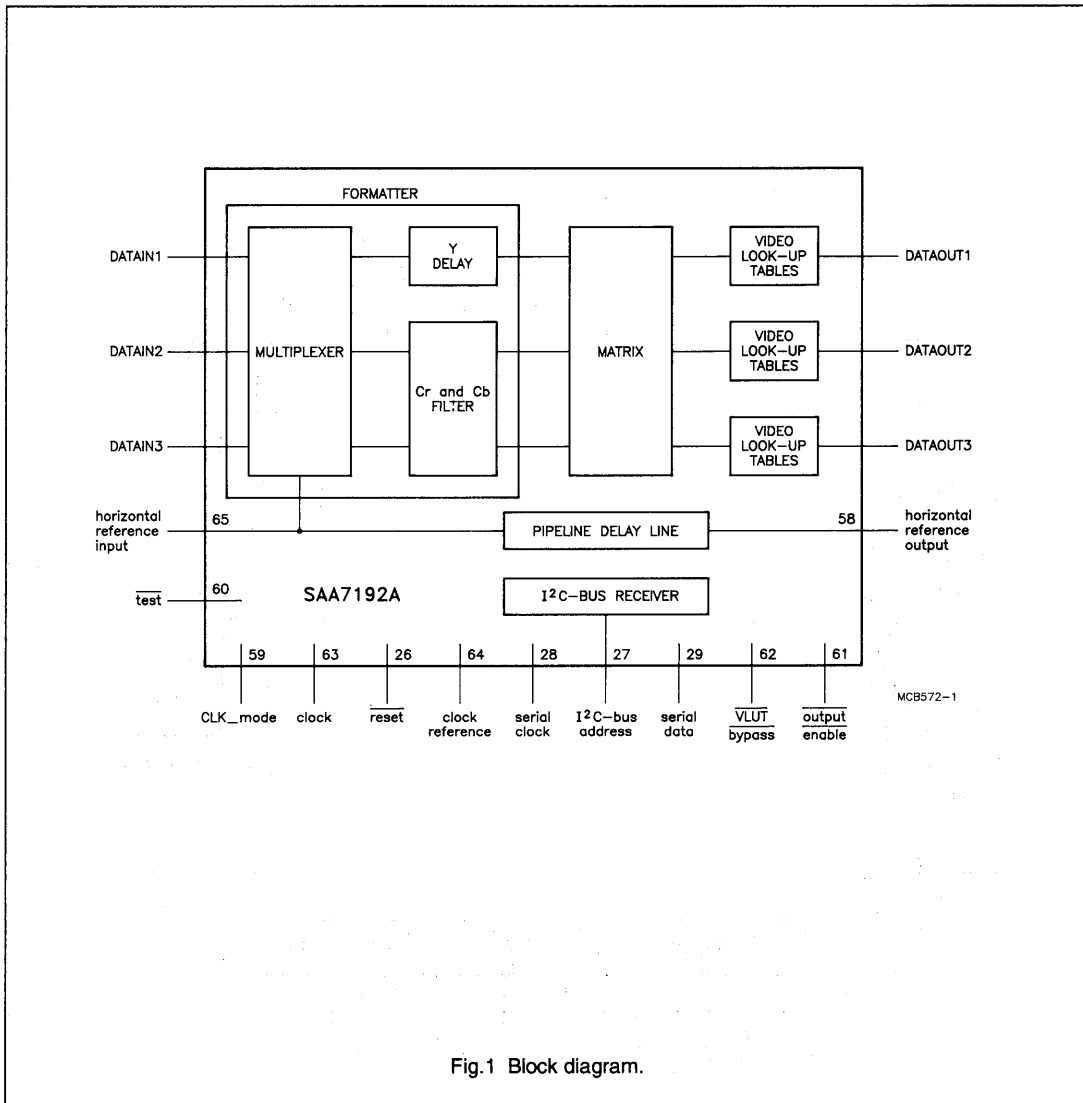

Fig.1 Block diagram.

Digital colour space converter

SAA7192A

PIN CONFIGURATION

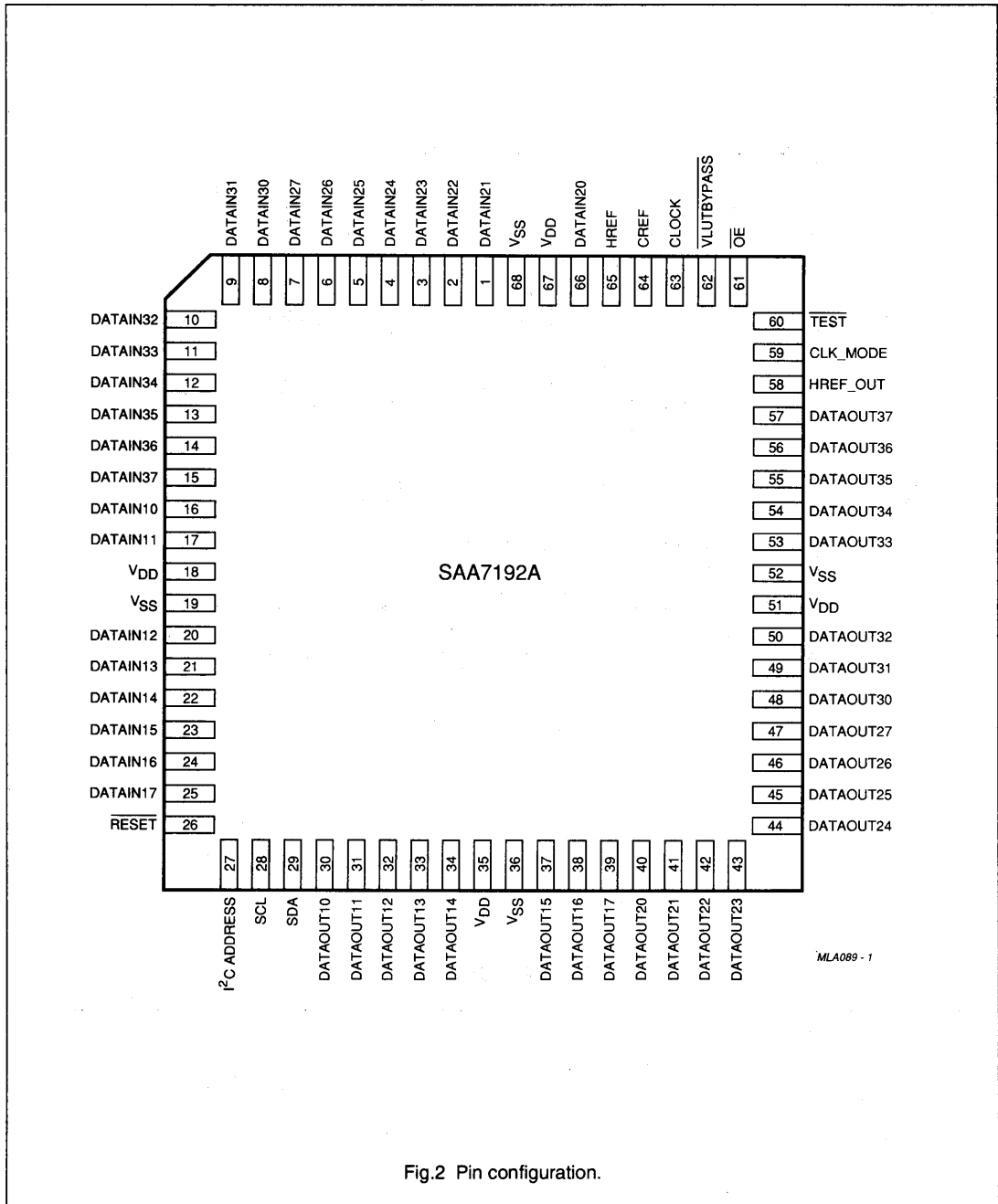

Fig.2 Pin configuration.



## Digital colour space converter

SAA7192A

## PINNING

SYMBOL	PIN	DESCRIPTION
DATAIN (10-17)	16-17 and 20-25	luminance signal Y (0-7)
DATAIN (20-27)	1-7 and 66	colour difference signal Cr (0-7)
DATAIN (30-37)	8-15	colour difference signal Cb (0-7) or multiplexed Cb and Cr
DATAOUT (10-17)	30-34 and 37-39	RED (0-7)
DATAOUT (20-27)	40-47	GREEN (0-7)
DATAOUT (30-37)	48-50 and 53-57	BLUE (0-7)
$\overline{\text{RESET}}$	26	initially resets the functions
HREF_OUT	58	delayed horizontal reference signal
CLK_MODE	59	16 MHz or DMSD clock mode selection
$\overline{\text{TEST}}$	60	test mode, usually not connected
$\overline{\text{OE}}$	61	output enable (fast switch)
VLUTBYPASS	62	fast switch to operate the VLUTs in bypass
CLOCK	63	system clock
CREF	64	clock reference signal (DMSD mode)
HREF	65	horizontal reference signal
$V_{DD}$	18, 67 35, 51	positive supply, voltage core (+ 5 V) positive supply voltage, output stages (+ 5 V)
$V_{SS}$	19, 68 36, 52	negative supply, voltage core (ground) negative supply, output stages
I <sup>2</sup> C-bus ADDRESS	27	I <sup>2</sup> C-bus SLAVE ADDRESS selection
SCL	28	I <sup>2</sup> C-bus SERIAL CLOCK input
SDA	29	I <sup>2</sup> C-bus SERIAL DATA input

## Note

All DATAIN and DATAOUT busses count from 0 (LSB) to 7 (MSB).

## Digital colour space converter

SAA7192A

## Functional modes

Table 1 Functional Modes

MODE	FUNCTION
1	4:1:1 filter, no matrix, no VLUT; DATAOUT = upsampled DATAIN
2	4:1:1 filter, matrix, no VLUT; DATAOUT = RGB
3	4:1:1 filter, no matrix, VLUT; DATAOUT = upsampled DATAIN multiplied by the factor loaded into the VLUT
4	4:1:1 filter, matrix, VLUT; DATAOUT = RGB multiplied by the factor loaded into the VLUT
5	4:2:2 filter, no matrix, no VLUT; DATAOUT = upsampled DATAIN
6	4:2:2 filter, matrix, no VLUT; DATAOUT = RGB
7	4:2:2 filter, no matrix, VLUT; DATAOUT = upsampled DATAIN multiplied by the factor loaded into the VLUT
8	4:2:2 filter, matrix, VLUT; DATAOUT = RGB multiplied by the factor loaded into the VLUT
9	no filter, no matrix, no VLUT; DATAOUT = DATAIN "Process Bypass"
10	no filter, matrix, no VLUT; DATAOUT = RGB
11	no filter, no matrix, VLUT; DATAOUT = DATAIN multiplied by the factor loaded into the VLUT.
12	no filter, matrix, VLUT; DATAOUT = RGB multiplied by the factor loaded into the VLUT

## Note

Figures 3 to 10 illustrate the various functional modes.

Digital colour space converter

SAA7192A

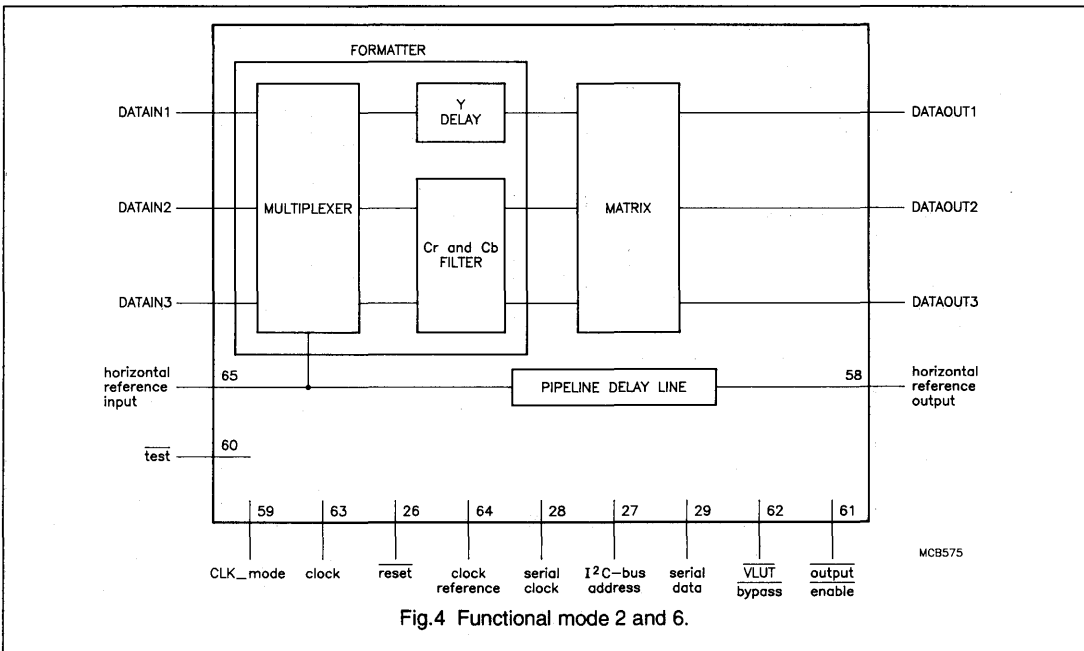
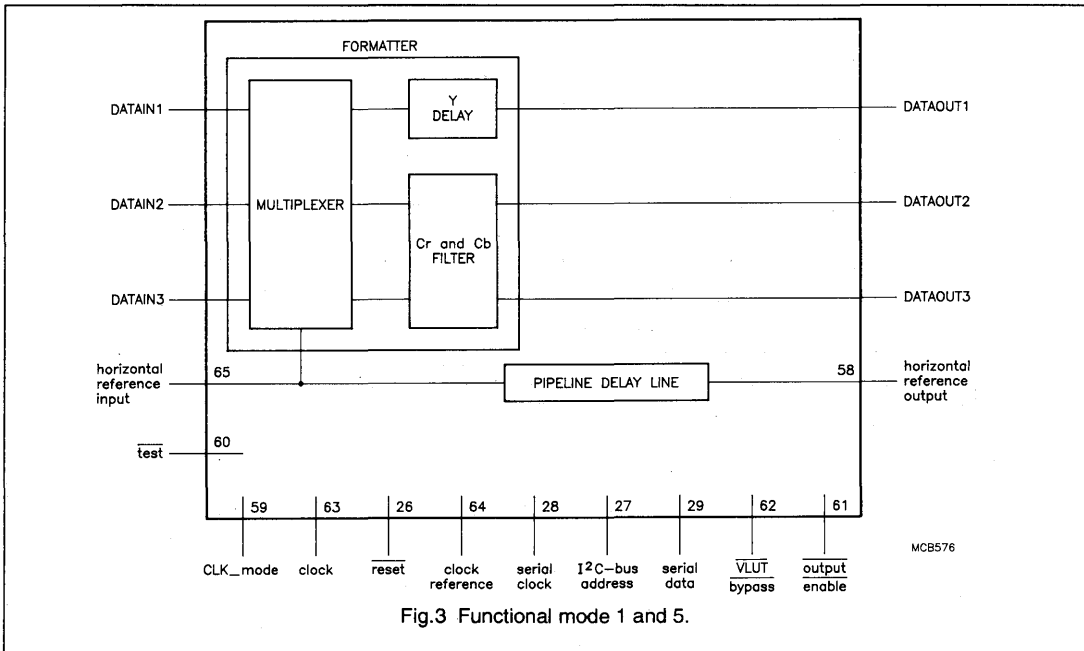

Digital colour space converter

SAA7192A

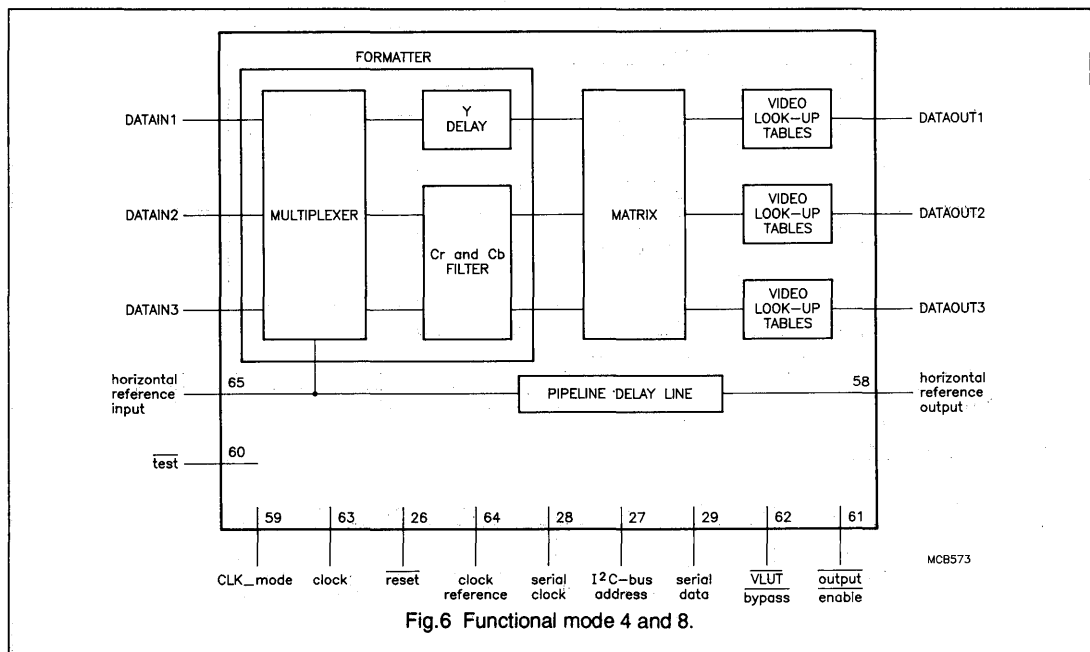
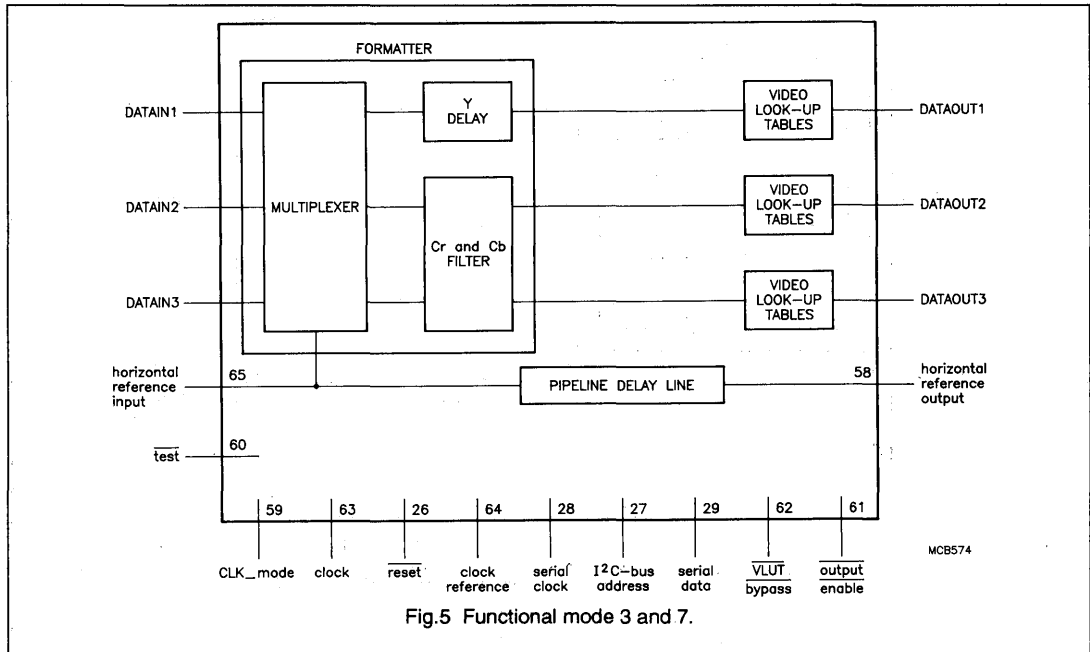

Digital colour space converter

SAA7192A

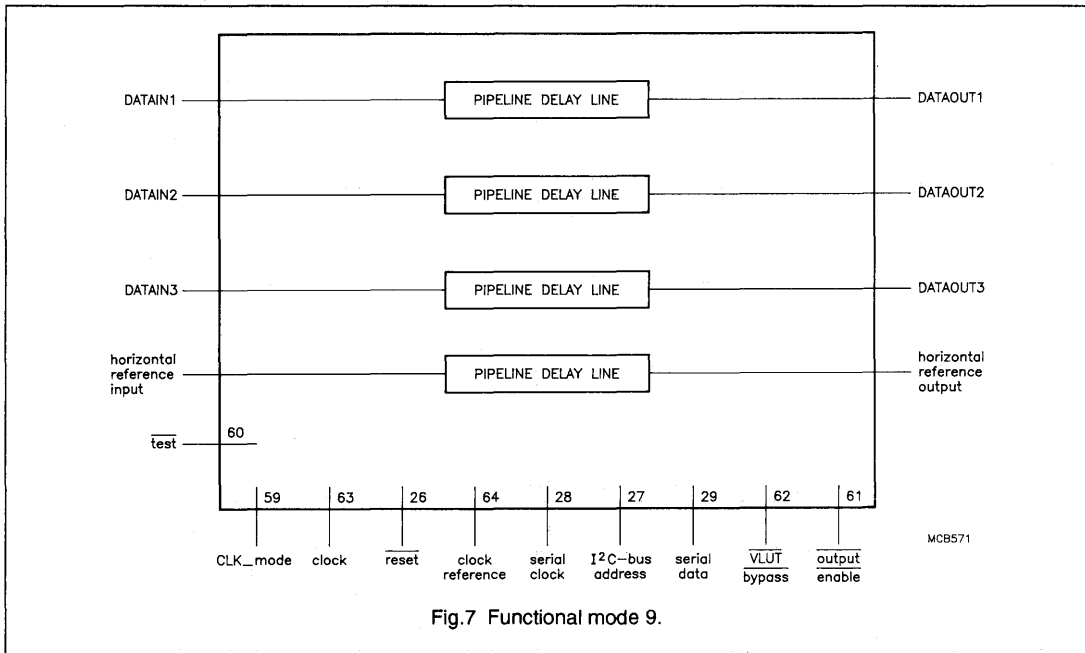

Fig.7 Functional mode 9.

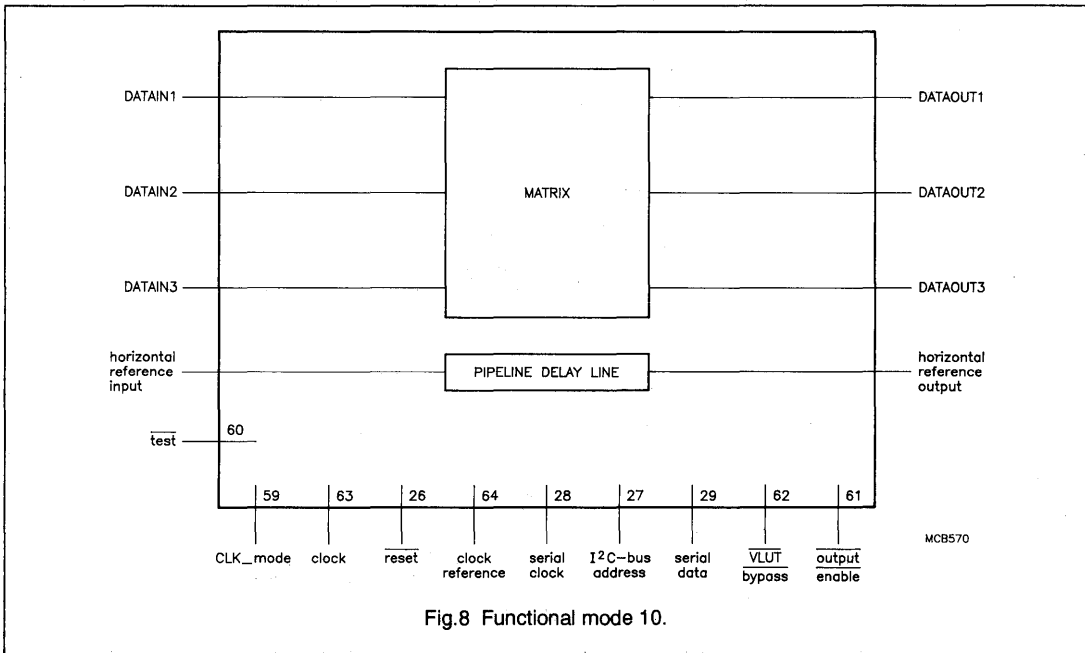
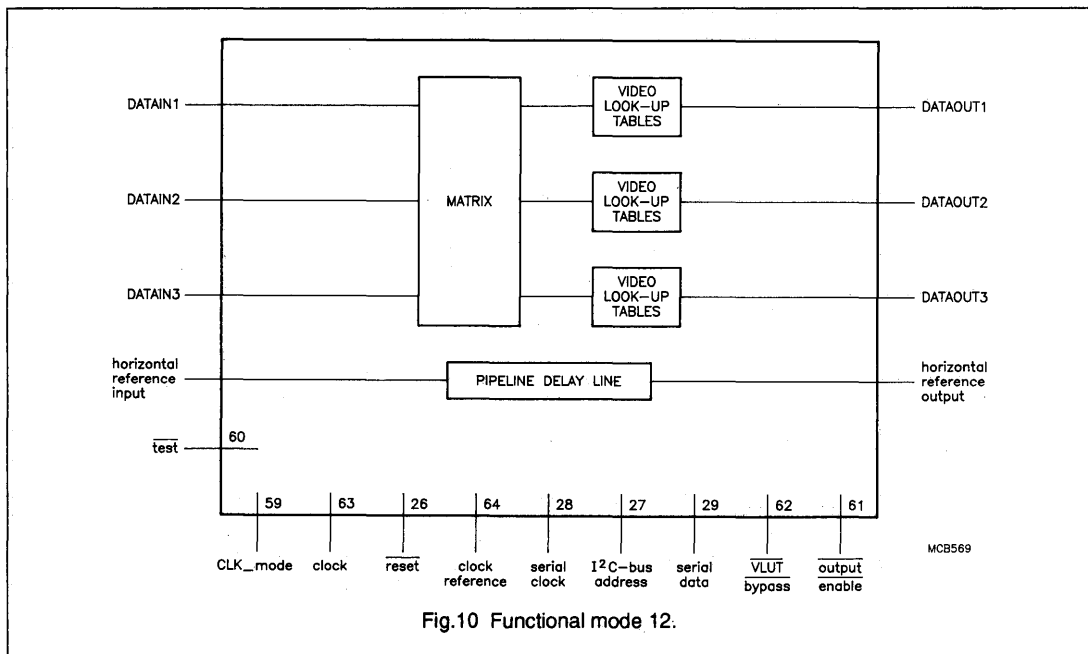
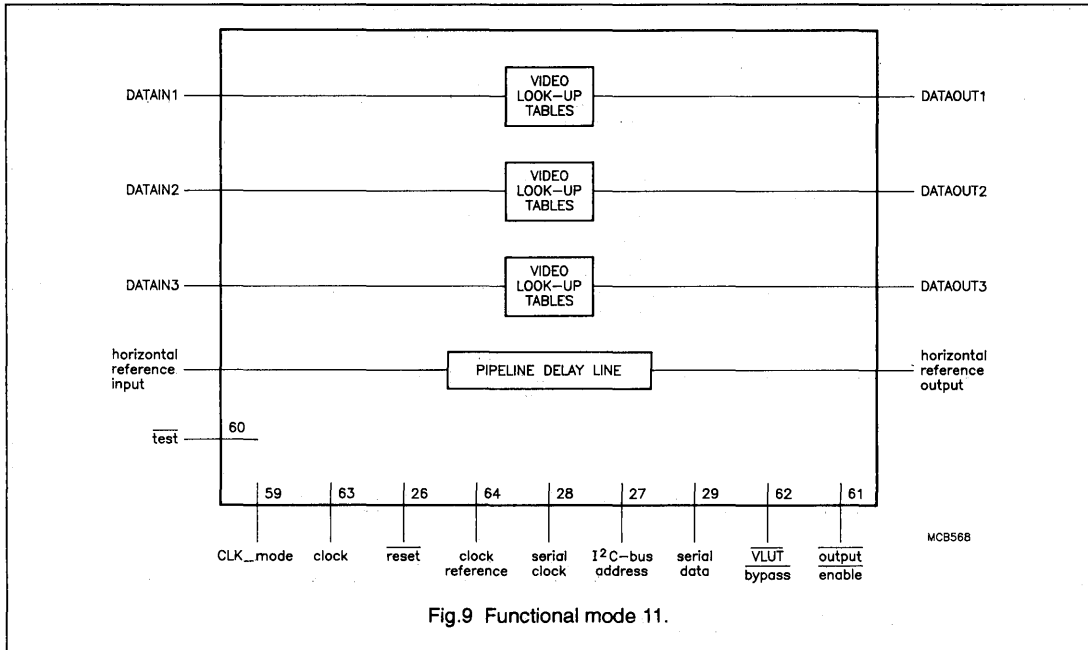

Fig.8 Functional mode 10.

Digital colour space converter

SAA7192A



## Digital colour space converter

SAA7192A

**Control facilities**

After power-up all device internal control signals are at undefined values. The I<sup>2</sup>C-bus receiver must, therefore, be reset by using the external RESET signal.

**Table 2** I<sup>2</sup>C-bus control signals (subadd 00H) after an external RESET is received

SYMBOL	BIT	STATUS
IICOE	D5	= 1 ; $\overline{OE}$ pin 61 enabled
FMTCNTRL	D0-D2	= 4 ; format 4:4:4
MATBYPASS	D3	= 0 ; matrix by-passed
INRESET	D4	= 0 ; input data set to fixed values

**Table 3** Input formats and functional modes

FMTCNTRL	MATBYPASS	VLUTBYPASS	FUNCTIONS
000	0	0	mode 1, input format 0 (DMSD2 format)
000	1	0	mode 2, input format 0 (DMSD2 format)
001	0	0	mode 1, input format 1
001	1	0	mode 2, input format 1
010	0	0	mode 5, input format 2 (DMSD2 format)
010	1	0	mode 6, input format 2 (DMSD2 format)
011	0	0	mode 5, input format 3 (parallel IN)
011	1	0	mode 6, input format 3 (parallel IN)
100	0	0	mode 9, input format 4 (parallel IN)
100	1	0	mode 10, input format 4 (parallel IN)
x	x	1	each of the above described modes will be multiplied by the factor loaded into the VLUT.

**Note**

The modes are given in Table 1.

## Digital colour space converter

SAA7192A

The other control signals are:

$\overline{\text{INRESET}}$	=	logic 1	:	input latches at the formatter are always transparent
	=	logic 0	:	at the end of each active video line the input latches have to be set to fixed values (Y to 16; Cr and Cb to 128; if HREF = 0)
CLK_MODE	=	logic 1	:	DMSD mode (LL27 clock of DMSD feeds the DCSC)
	=	logic 0	:	DCSC is fed by a maximum 16 MHz clock without CREF signal.

Table 4 Output enable control

IICOE	$\overline{\text{OE}}$	CONTROL LINE TO DRIVER STAGES
0	X	1 = DATAOUT in high impedance mode
1	1	1 = DATAOUT in high impedance mode
1	0	0 = DATAOUT working

**Notes**

IICOE : D5; output enable control of I<sub>2</sub>C-bus (enables  $\overline{\text{OE}}$ )

$\overline{\text{OE}}$  : pin 61 ; output enable (fast switch)



## Digital colour space converter

SAA7192A

## SYSTEM I/O INTERFACES

## Input signals

**Table 5** Format 0 (4:1:1, semi-parallel, DMSD2 decoder family format)

DATAIN1 - Y	luminance signal, 8-bit
Sampling frequency	12 to 16 MHz
Level	0 IRE; black, quantization level 16 100 IRE; white, quantization level 235
DATAIN3 - U, V	multiplexed colour difference signals 4-bit; corresponds to UV7 to UV4 of DMSD2
Sampling frequency	1/4 of the Y signal
Level	bottom peak; quantization level 16 top peak; quantization level 240 colourless; quantization level 128
DATAIN2	not used

**Table 6** Timing of Format 0; pin (DATAIN) and bit (U,V) numbers are indicated except clock

Y; 7 to 0	Y	Y	Y	Y	Y	Y	Y
DATAIN 37	U7	U5	U3	U1	U7	U5	U3
DATAIN 36	U6	U4	U2	U0	U6	U4	U2
DATAIN 35	V7	V5	V3	V1	V7	V5	V3
DATAIN 34	V6	V4	V2	V0	V6	V4	V2
Clock A	1	2	3	4	5	6	7

**Note**

Clock\_A is the internal sampling clock of the system. The clock rate of the DMSD and the DCSC is twice that of Clock\_A in this mode.

**Table 7** Format 1 (4:1:1, semi-parallel, customized format)

DATAIN1 - Y	luminance signal; 8-bit
Sampling frequency	12 to 16 MHz
Level	0 IRE; black; quantization level 16 100 IRE; white; quantization level 235
DATAIN3 - Cr, Cb	multiplexed colour difference signals, 8-bit
Sampling frequency	1/4 of the Y signal
Level	bottom peak; quantization level 16 top peak; quantization level 240 colourless; quantization level 128
DATAIN2	not used

## Digital colour space converter

SAA7192A

**Table 8** Timing of Format 1; the indices show the clock (sample) number

Y	Y0	Y1	Y2	Y3	Y4	Y5	Y6
Cr, Cb	Cb0		Cr0		Cb4		Cr4
Clock A	0	1	2	3	4	5	6

**Note**

Clock\_A is the internal sampling clock of the system. The external CLOCK may differ from the CLK\_MODE.

**Table 9** Format 2 (4:2:2, semi-parallel, DMSD2 format)

DATAIN1 Y	luminance signal; 8-bit
Sampling frequency	12 to 16 MHz
Level	0 IRE; black; quantization level 16 100 IRE; white; quantization level 235
DATAIN3 - Cr, Cb	multiplexed colour difference signals; corresponds to UV7 to UV0 of DMSD2
Sampling frequency	1/2 of the Y signal
Level	bottom peak; quantization level 16 top peak; quantization level 240 colourless; quantization level 128
DATAIN2	not used

**Table 10** Timing of Format 2

Y	Y0	Y1	Y2	Y3	Y4	Y5	Y6
Cr, Cb	Cb0	Cr0	Cb2	Cr2	Cb4	Cr4	Cb6
Clock A	0	1	2	3	4	5	6

**Note**

Clock\_A is the internal sampling clock of the system. The clock of the DMSD (also the CLOCK of the DCSC) is twice that of Clock\_A in this mode.

## Digital colour space converter

SAA7192A

**Table 11** Format 3 (4:2:2, Y-Cr-Cb, parallel)

DATAIN1 - Y	luminance signal; 8-bit
Sampling frequency	12 to 16 MHz
Level	0 IRE; black; quantization level 16 100 IRE; white; quantization level 235
DATAIN3 - Cb	colour difference signal B-Y, 8-bit
Sampling frequency	1/2 of the Y signal
Level	bottom peak; quantization level 16 top peak; quantization level 240 colourless; quantization level 128
DATAIN2 - Cr	colour difference signal R-Y, 8-bit
Sampling frequency	1/2 of the Y signal
Level	bottom peak; quantization level 16 top peak; quantization level 240 colourless; quantization level 128

**Table 12** Timing of Format 3

Y	Y0	Y1	Y2	Y3	Y4	Y5	Y6
Cb	Cb0		Cb2		Cb4		Cb6
Cr	Cr0		Cr2		Cr4		Cr6
Clock A	0	1	2	3	4	5	6

**Note**

Clock\_A is the internal sampling clock of the system. The external CLOCK may differ from the CLK\_MODE.

**Table 13** Format 4 (4:4:4, Y-Cr-Cb, parallel)

DATAIN2 - Cr	colour difference signal R-Y, 8-bit
Sampling frequency	as the Y signal
Level	bottom peak; quantization level 16 top peak; quantization level 240 colourless, binary 128
DATAIN3 - Cb	colour difference signal B-Y, 8-bit
Sampling frequency	as the Y signal
Level	bottom peak; quantization level 16 top peak; quantization level 240 colourless; quantization level 128
DATAIN1 - Y	luminance signal; 8-bit
Sampling frequency	12 to 16 MHz
Level	0 IRE; black; quantization level 16 100 IRE; white; quantization level 235

## Digital colour space converter

SAA7192A

## VIDEO DATA (DATAIN)

**Table 14** Timing of Format 4

Y	Y0	Y1	Y2	Y3	Y4	Y5	Y6
Cb	Cb0	Cb1	Cb2	Cb3	Cb4	Cb5	Cb6
Cr	Cr0	Cr1	Cr2	Cr3	Cr4	Cr5	Cr6
Clock A	0	1	2	3	4	5	6

**Note**

Clock\_A is the internal sampling clock of the system. The external CLOCK may differ from CLK\_MODE.

**CONTROL DATA****Clock**

The CLK-Mode signal is used to select the frequency of the system clock (denoted as CLOCK at the DCSC input) and may be chosen from two different Clock Modes.

**16 MHz-Mode:**

DCSC is used in any environment except that of the DMSD2 decoder family. The clock reference signal (CREF) is internally set HIGH in value.

The maximum CLOCK frequency is 16 MHz.

**DMSD-Mode:**

DCSC is used in a DMSD environment.

The CLOCK signal (LL27) and the CREF signal are fed by the clock generator circuit (SAA7157/SAA7197) and the line

locked clock LL27 (denoted as CLOCK at the DCSC input) is twice the data rate of that specified for the DMSD2 family of decoders. The data rate is denoted as CLOCK\_A in Tables 6, 8, 10, 12 and 14.

The data rate on the input (DATAIN) is as follows:

- 12.2727 MHz; 60 Hz signals (from SAA7191)
- 13.5 MHz; CCIR signals (from SAA7151)
- 14.75 MHz; 50 Hz signals (from SAA7191)
- 16.0 MHz; maximum frequency

**TIMING REFERENCE**

The timing reference signal from the SAA7151/7191 is used to synchronize the multiplexer and refers to the LL27 clock. Each alternative positive slope, marked by a CREF signal, is used to obtain data.

The horizontal reference signal, HREF, indicates the active part of a line and also synchronizes the multiplexer.

**CREF** The clock reference signal is a clock qualifier signal distributed by the clock generator of the DMSD system. The frequency is identical to the sample rates denoted in the input and the output formats (see Video data and Operating conditions).

**HREF** Horizontal reference signal is the line reference signal of the YUV-bus. A positive slope marks the beginning of the active part of a line. The length of the active part corresponds to the number of samples (see Operating conditions).

## Digital colour space converter

SAA7192A

**Table 15** Real-time control signals

$\overline{OE}$	pin 61	= 1 : = 0 :	switches the output to high-z mode output enable, output stage in use
VLUTBYPASS	pin 62	= 1 : = 0 :	VLUT's in use VLUT's bypassed
RESET	pin 26	= 1 : = 0 :	device in use general reset
CLK_MODE	pin 59	= 1 : = 0 :	DMSD mode (LL27 clock of DMSD feeds the DCSC) DCSC is fed by a clock signal with a maximum data rate of 16 MHz (without CREF signal).

**Table 16** I<sup>2</sup>C-bus controls (sub-add. VLUTDATA)

VLUTDATA FED TO	SUB-ADD
RAM 1 (RED)	01H
RAM 2 (GREEN)	02H
RAM 3 (BLUE)	03H
RAM 1, 2, 3	04H

**Note**

See also example of VLUT programming Fig. 23.

## Digital colour space converter

SAA7192A

Table 17 I<sup>2</sup>C-bus controls (sub-add. 00H)

FMTCTRL	D0-D2	= 000 :	4:1:1 format, DMSD2 format
		= 001 :	4:1:1 format, customized format
		= 010 :	4:2:2 format, from DMSD2
		= 011 :	4:2:2 format, parallel
		= 100 :	4:4:4 format, parallel
		= 101 :	not used
		= 110 :	not used
		= 111 :	not used
MATBYPASS	D3	= 1 :	matrix in use
		= 0 :	matrix bypassed
INRESET	D4	= 1 :	input latches at the formatter are always transparent
		= 0 :	at the end of each active video line the input latches have to be set to fixed values (Y to 16; Cr, Cb to 128; if HREF = 0)
IICOE		D5 = 1 :	$\overline{OE}$ enabled
		= 0 :	switches the output to high impedance mode

## OUTPUT SIGNALS

## Video data

Table 19 Timing of DATAOUT (R-G-B if matrix in use)

Timing :							
the indices show the clock sample number							
DATAOUT1 :	R0	R1	R2	R3	R4	R5	R6
DATAOUT2 :	G0	G1	G2	G3	G4	G5	G6
DATAOUT3 :	B0	B1	B2	B3	B4	B5	B6
Clock_A :	0	1	2	3	4	5	6

## Notes

Clock\_A is the internal sampling clock of the system. The system clock may differ from CLK-MODE.

$\overline{OE}$  (output enable, fast switch, active LOW) and IICOE (I<sup>2</sup>C-bus output enable, active HIGH) will switch the DATAOUT lines in high-z or normal mode.

See also Fig. 14.

## Digital colour space converter

SAA7192A

**Auxiliary data**

Pipelined external reference signal HREF\_OUT (delayed HREF).

The delay line (wordlength 1-bit) has the same duration as the signal processing of the video data lines.

**OPERATING CONDITIONS****Electrical Conditions**

## START-UP CONDITION

No particular function except the external power-on-reset e.g. for I<sup>2</sup>C-bus interface (RESET) is intended.

## OPERATING TIME

As this device will be used in computers, it has been designed to operate continuously.

## HANDLING

Inputs and outputs are protected against electrostatic discharge during normal handling. It is desirable, however, to observe normal handling precautions appropriate to MOS devices.

## TEMPERATURE RANGE

Refer to the characteristics.

## BACKUP

No internal backup capability (standby) is provided.

## POWER DOWN MODE

No internal power-down capability is provided.

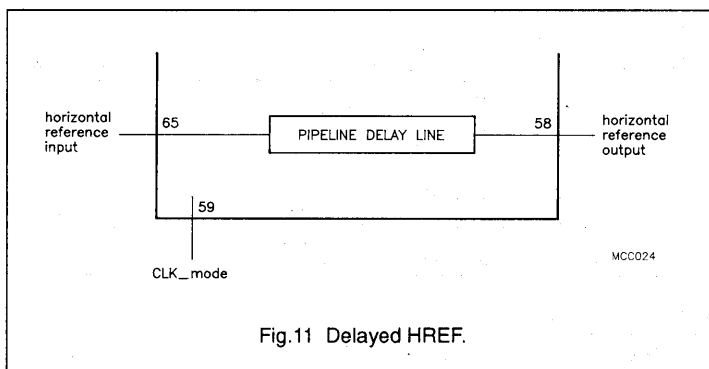

Fig.11 Delayed HREF.

## Digital colour space converter

SAA7192A

## LIMITING VALUES

SYMBOL	PARAMETER	MIN	MAX	UNIT
V <sub>DD</sub>	Supply voltage	-0.5	7	V
V <sub>I</sub>	input voltage	-0.5	7	V
V <sub>O</sub>	output voltage	-0.5	7	V
P <sub>tot</sub>	total power dissipation	-	1.5	W
T <sub>stg</sub>	storage temperature range	-65	+150	C
T <sub>amb</sub>	operating ambient temperature	0	+70	C

## CHARACTERISTICS

SYMBOL	PARAMETER	CONDITION	MIN	MAX	UNIT
V <sub>DD</sub>	supply voltage		4.5	5.5	V
I <sub>DD</sub>	supply current	note 1	-	150	mA
<b>Inputs</b>					
V <sub>IL</sub>	input voltage LOW				
	SDA, SCL		-0.5	1.5	V
	any other		-0.5	0.8	V
V <sub>IH</sub>	input voltage HIGH				
	SDA, SCL		3	V <sub>DD</sub> +0.5	V
	any other		2	V <sub>DD</sub> +0.5	V
I <sub>L</sub>	input leakage current	note 2	-	10	μA
C <sub>I</sub>	input capacitance		-	10	pF
<b>Outputs</b>					
V <sub>OH</sub> V <sub>OL</sub>	output voltage				
	HIGH (any)		2.4	V <sub>DD</sub>	V
	LOW (SDA)		0	0.4	V
	LOW (any other)		0	0.4	V
I <sub>OH</sub> I <sub>OL</sub>	output current				
	HIGH (any)		-	4	mA
	LOW (SDA)		-	3	mA
	LOW (any other)		-	4	mA
C <sub>Ld</sub>	output load capacitance		-	40	pF
I <sub>O</sub>	output leakage current		-	10	μA

## Notes

- 1 The supply current may vary between 30 and 150 mA depending upon the input data. The minimum may be achieved with  $\overline{OE}$  disabled and no clock
- 2 All inputs except  $\overline{TEST}$  (internal pull-up resistor).



## Digital colour space converter

SAA7192A

## TIMING CHARACTERISTICS

SYMBOL	PARAMETER	CONDITION	MIN	TYP	MAX	UNIT
t <sub>C27</sub>	propagation delay CLOCK (DMSD-mode, LL27) :	note 2 note 3	-	26		t <sub>C16</sub>
	cycle time		31	-	45	ns
	duty cycle		40	-	60	%
t <sub>C16</sub> t <sub>CDL</sub> t <sub>CDH</sub>	CLOCK (16 MHz-mode) :	note 4				
	cycle time		62	-	83	ns
	duty time LOW		30	-	-	ns
	duty time HIGH		16	-	-	ns
t <sub>CS</sub> t <sub>CH</sub>	CREF					
	set-up time		11	-	-	ns
	hold time		3	-	-	ns
t <sub>HS</sub> t <sub>HH</sub>	HREF					
	set-up time		11	-	-	ns
	hold time		3	-	-	ns
t <sub>RH</sub>	RESET hold time		4 clock periods			
t <sub>VS</sub> t <sub>VH</sub>	VLUTBYPASS	note 5				
	set-up time		8	-	-	ns
	hold time		0	-	-	ns
	CLK_MODE set-up time		must be set before RESET			
	I <sup>2</sup> C-bus address set-up time		must be set before RESET			
t <sub>SU</sub> t <sub>HD</sub>	DATAIN					
	set-up time		11	-	-	ns
	hold time		3	-	-	ns
t <sub>OS</sub> t <sub>OH</sub>	DATAOUT					
	set-up time		10	-	-	ns
	hold time		10	-	-	ns
t <sub>OHS</sub> t <sub>OHH</sub>	HREF_OUT					
	set-up time		9	-	-	ns
	hold time		10	-	-	ns
t <sub>HZ</sub> t <sub>ZH</sub>	output disable time (to tri-state) output enable time (from tri-state)					
			-	10	15	ns
				15	21	ns

## Notes

- 1 Typical ratings are measured at V<sub>DD</sub> = 5 V and 25 °C room temperature
- 2 Denotes the delay in clock periods between DATAIN and DATAOUT
- 3 DMSD-mode designates that the DCSC will work in a DMSD environment. The CLOCK and the clock reference signal CREF will be fed by the SCGC (SAA7157). This is further explained in the following diagrams.
- 4 16 MHz-mode indicates that the DCSC will work in any other environment. The CREF signal will be set internally to HIGH, the CLOCK signal can be any clock up to 16 MHz (see also Fig. 15).
- 5 Must be set one clock period before DATAOUT.

# Digital colour space converter

# SAA7192A

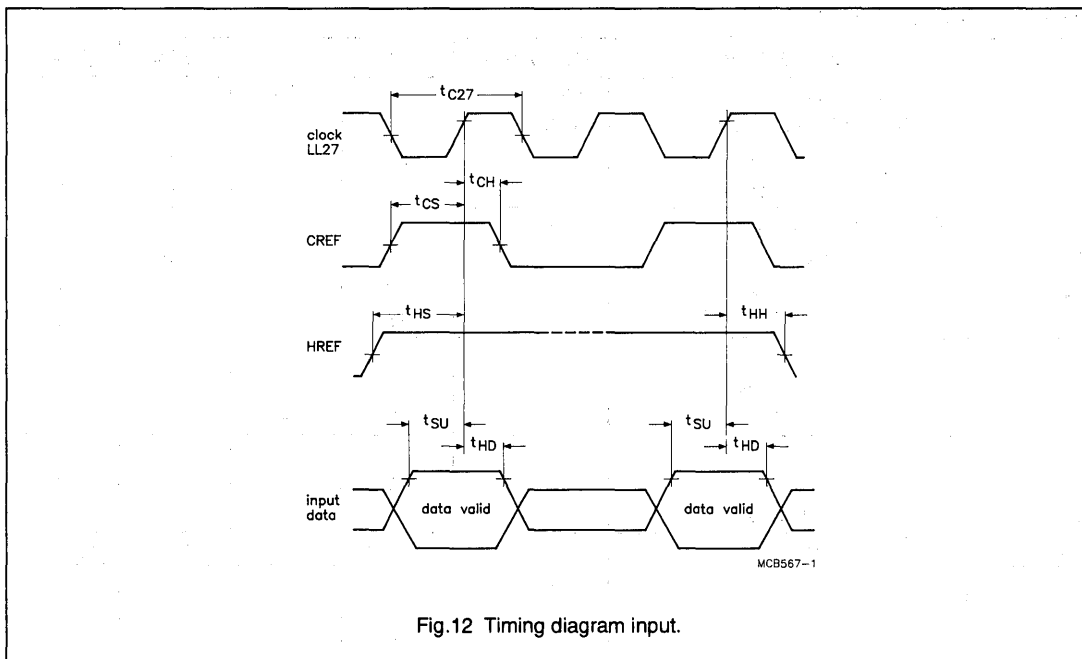

Fig.12 Timing diagram input.

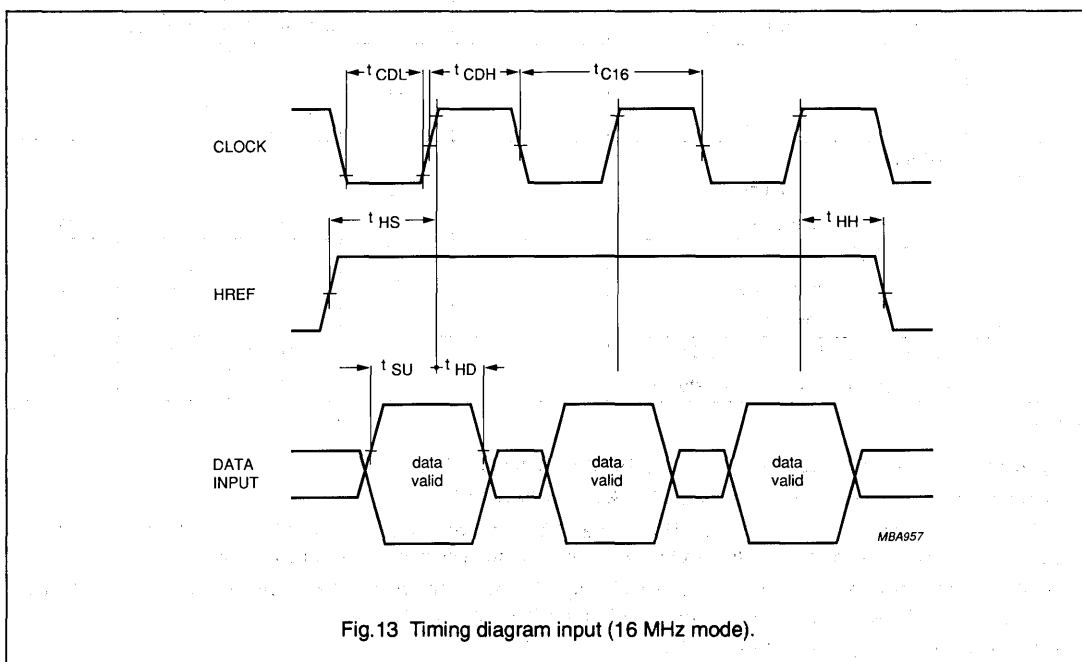
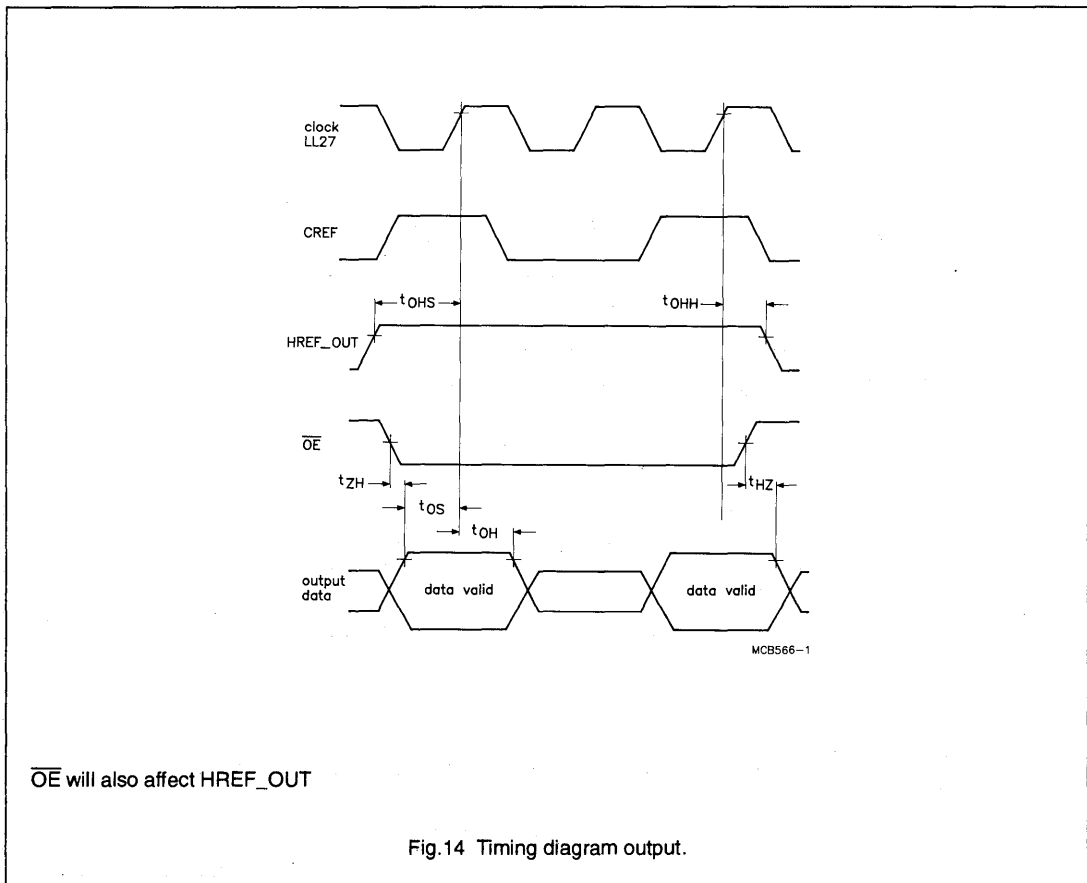

Fig.13 Timing diagram input (16 MHz mode).

Digital colour space converter

SA A7192A



**Error condition**

To inhibit unwanted operations, no information signal is available to the peripheral circuits. In the advent of an error the system must be re-started by application of the RESET signal.

## Digital colour space converter

SAA7192A

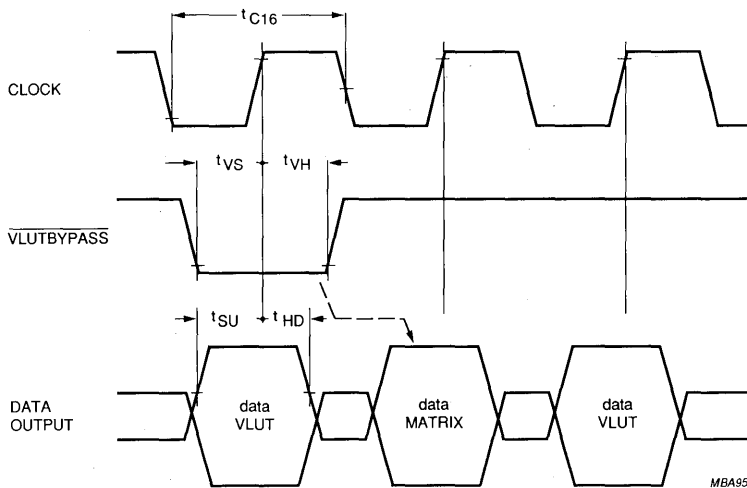

VLUTBYPASS must be supplied one clock pulse in advance of the desired DATAOUT lines reaction.

Fig.15 Timing diagram VLUTBYPASS

### SYSTEM BLOCK DESCRIPTION

#### Input formatter

The formatter consists of five functional blocks:

- the multiplexer, which decodes the luminance and chrominance input signals
- the filter, which interpolates the samples of the incoming signal to get an upsampled data rate as at DATAIN1
- the luminance delay line
- the timing control which creates the internal reference signals from the various inputs
- the bypass output multiplexer

The data applied at DATAIN1 to DATAIN3 is converted as follows;

FIL1 : Y Luminance  
 FIL2 : Cr colour-difference signal R-Y  
 FIL3 : Cb colour-difference signal B-Y

Digital colour space converter

SAA7192A

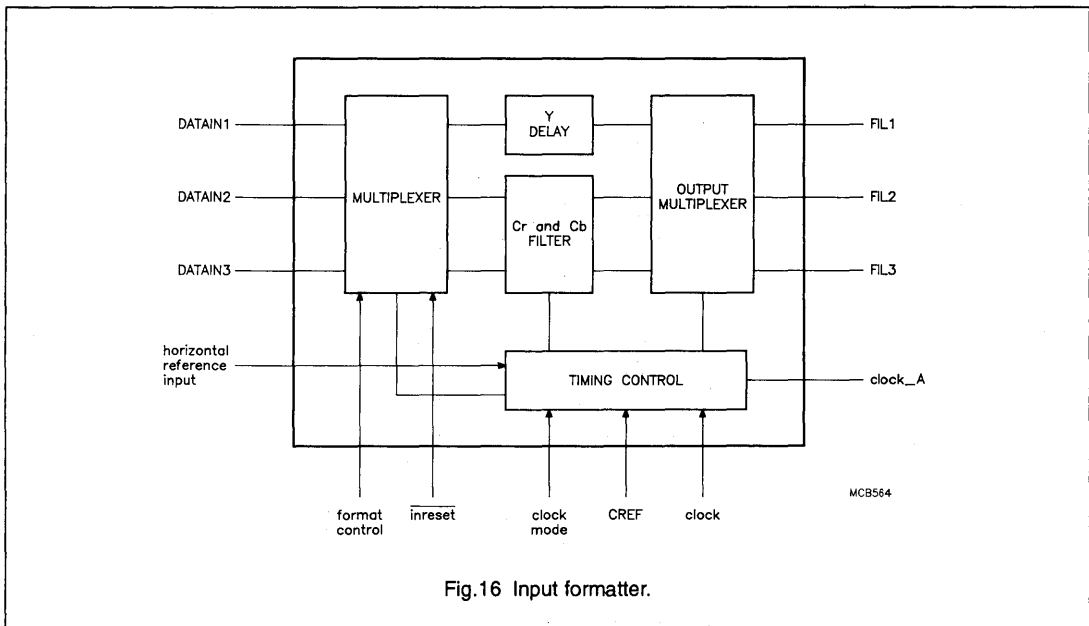

Fig.16 Input formatter.

**Filter and delay line**

In the various functional modes the signal FMTCNTRL switches in the required filters (FMTCNTRL is described in 'Control data'). In all modes the same propagation delay will be realized, (the reference is Cb0, respective to U7 with format 0). At all frequencies and in all formats, there is a delay line to compensate for the delay of the signal processing time needed in the chrominance section.

**CHROMINANCE FILTER**

The filter for the Cr and Cb signal is realized in one filter design.

Format 1, 2                      4:1:1

An interpolating filter is inserted to convert the original sampling frequency to the sampling frequency of the luminance signal i.e. four times that of the colour signal. Figure 17 illustrates the frequency response of the chrominance section.

Format 3, 4                      4:2:2

An interpolating filter is inserted to convert the original sampling frequency to the sampling frequency of the luminance signal i.e. twice the colour signal. Figure 18 illustrates the frequency response of the chrominance section.

Format 5                          4:4:4

A bypass with a specified delay is inserted.

Digital colour space converter

SAA7192A

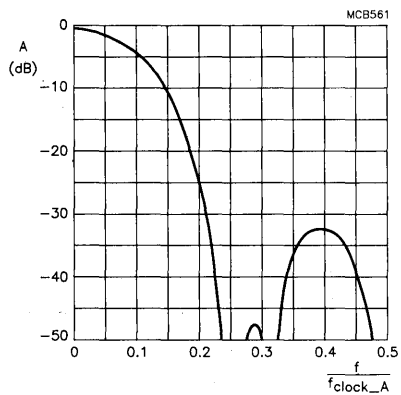

Fig.17 Frequency response of 4:1:1 filter.

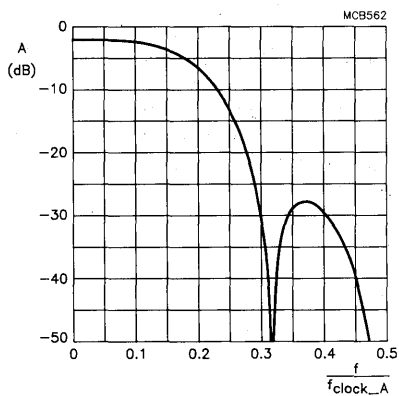

Fig.18 Frequency response of 4:2:2 filter

## Digital colour space converter

SAA7192A

## CONVERSION MATRIX

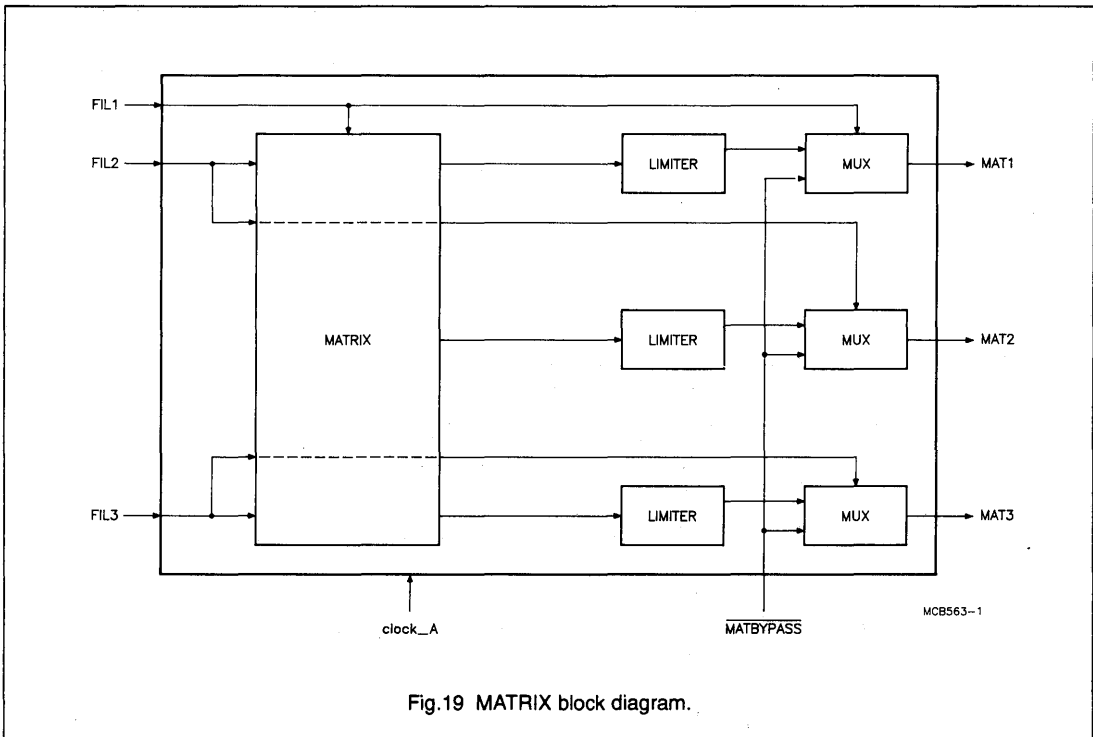

Fig.19 MATRIX block diagram.

The properties of the conversion matrix are as follows:

- the conversion equations are (according to CCIR 601, with respect to the different quantisation on Y, Cb and Cr);  
 Red =  $Y + 1.371 (Cr - 0.5)$   
 Green =  $Y - 0.698 (Cr - 0.5) - 0.336 (Cb - 0.5)$   
 Blue =  $Y + 1.732 (Cb - 0.5)$

- the accuracy of the signal processing is within  $\pm 0.5\%$  of the accuracy of a theoretical conversion.
- the input and output data lines are 8-bit.
- in the advent of non-standard input levels, the limiter reduces the possible output data values to between 0 and 255.

- MATBYPASS switches the matrix in bypass. The bypass has the same propagation delay as the matrix itself.

Digital colour space converter

SAA7192A

VIDEO LOOK-UP TABLE AND OUTPUT STAGE

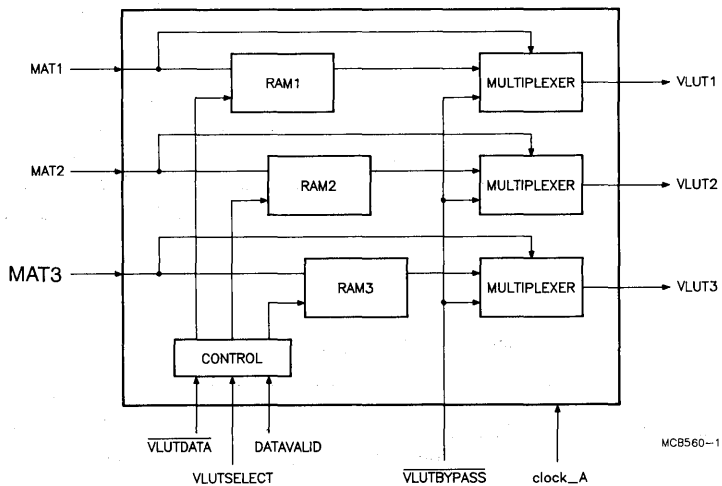

Fig.20 Block diagram video look up table.



# Digital colour space converter

# SAA7192A

## Functional description

The  $\overline{\text{VLUTLOAD}}$  will be set to the WRITE operation if one of the four addresses are received from the RAMs.  $\overline{\text{VLUTLOAD}}$  will be set to the READ operation following reception of the last databyte.

VLUTSELECT provides selection of one VLUT according to the sub-address.

VLUTDATA contains the value for the address counter (VLUT\_ADDRESS; the start address of the first byte to be written into the RAM) and the data for the RAMs, validated with DATAVALID.

The databytes will be loaded by an autoincrement function.

$\overline{\text{VLUTBYPASS}}$  will bypass the VLUT's in clock period time (real time switch).

In computer applications the VLUT is also known as a Colour Look-Up Table (CLUT).

In the DCSC this table might be used to invert the Gamma-correction of a camera. This correction is applied to compensate for the non-linear relationship between the video voltage applied to the cathode and the light output of the phosphor of a CRT.

The Gamma-correction function (also known as Gradation) is given as;

$$Y = X^\gamma$$

The VLUT's are realized by 256 x 8-bit RAMs.

## I<sup>2</sup>C-bus RECEIVER

The DCSC can be switched to different functional modes via the I<sup>2</sup>C-bus receiver. The I<sup>2</sup>C-bus receiver is also used to feed the VLUT RAMs with data.

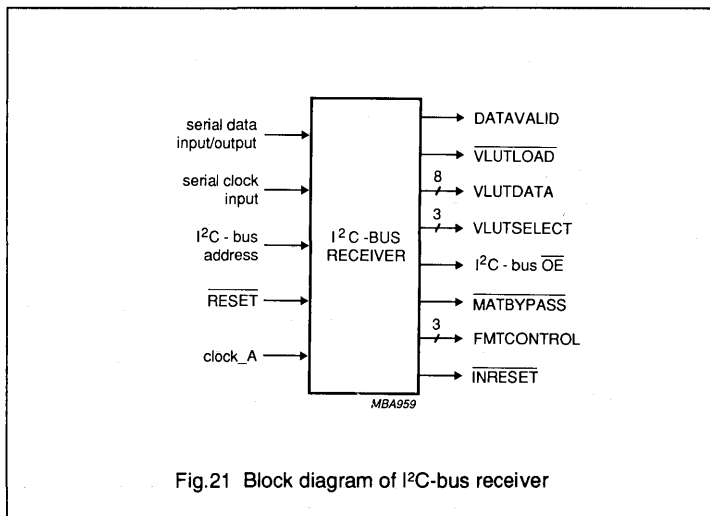

Fig.21 Block diagram of I<sup>2</sup>C-bus receiver

## I<sup>2</sup>C-bus Receiver Functional Description

Following power-up, all internal control signals are at undefined values. The I<sup>2</sup>C-bus receiver must be reset by the external  $\overline{\text{RESET}}$  signal. Following  $\overline{\text{RESET}}$  the control signals are set to:

$\overline{\text{FMTCNTRL}}$	:=	100	format 4:4:4
$\overline{\text{MATBYPASS}}$	:=	0	matrix bypassed
$\overline{\text{INRESET}}$	:=	0	input data set to fixed values
$\overline{\text{IICOE}}$	:=	1	$\overline{\text{OE}}$ enabled



## Digital colour space converter

## SAA7192A

Table 20 Levels of the colour bar signal

CONDITION	$E'_R$	$E'_G$	$E'_B$	Y	$C_R$	$C_B$	R	G	B
White	1.0	1.0	1.0	235	128	128	235	235	235
Black	0	0	0	16	128	128	16	16	16
Red	1.0	0	0	82	240	90	236	17	16
Green	0	1.0	0	145	34	54	16	236	17
Blue	0	0	1.0	41	110	240	16	16	235
Yellow	1.0	1.0	0	210	146	16	235	235	16
Cyan	0	1.0	1.0	170	16	166	16	235	236
Magenta	1.0	0	1.0	106	222	202	235	15	234

## Note

The colour bar signal is described in CCIR 601, Rep. 629-2, Table 1. It can be used to check the nominal levels (at least for black and white) between the functional blocks of the DCSC.

Table 21 Control byte formats

D7	D6	D5	D4	D3	D2	D1	D0	Functions
x	x	x	x	x	0	0	0	input formatter at format 0 Filter switched to 4:1:1 filter
x	x	x	x	x	0	0	1	input formatter at format 1 Filter switched to 4:1:1 filter
x	x	x	x	x	0	1	0	input formatter at format 2 Filter switched to 4:2:2 filter
x	x	x	x	x	0	1	1	input formatter at format 3 Filter switched to 4:2:2 filter
x	x	x	x	x	1	0	0	input formatter at format 4 Filter switched to bypass
x	x	x	x	0	x	x	x	matrix bypassed
x	x	x	x	1	x	x	x	matrix in use
x	x	x	0	x	x	x	x	input data at fixed values
x	x	x	1	x	x	x	x	input data to formatter
x	x	0	x	x	x	x	x	output stages tri-state
x	x	1	x	x	x	x	x	OE enabled

D0-D2

FMTCONTROL

D3

MATBYPASS

D4

INRESET

D5

IICOE

D6

not used

D7

not used

Digital colour space converter

SAA7192A

VLUTDATA

Four sub-addresses are implemented to convey data into the different VLUT RAMs. RAM can be addressed individually or together. The memory of each VLUT RAM can be addressed, e.g. if only parts of the data has to be changed.

Table 22 Sub-addresses VLUTDATA:

SUB-ADDRESS	VLUT-ADDRESS	DATA BYTEs
01	xx	VLUTDATA RAM 1 (RED)
02	xx	VLUTDATA RAM 2 (GREEN)
03	xx	VLUTDATA RAM 3 (BLUE)
04	xx	VLUTDATA RAM 1, 2, 3

Note

(\* ) addresses in HEX representation

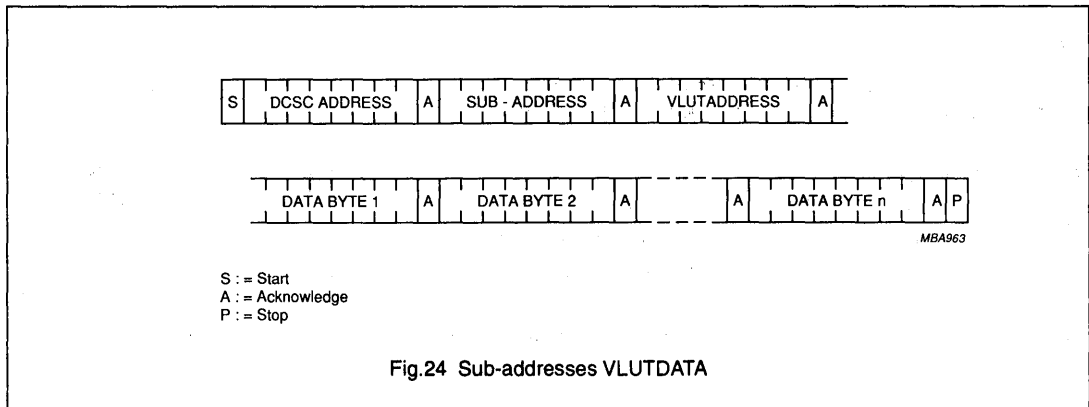

S : = Start  
 A : = Acknowledge  
 P : = Stop

Fig.24 Sub-addresses VLUTDATA

I<sup>2</sup>C-bus receiver timing examples

The exact timing of the signals are described in the I<sup>2</sup>C-bus specification. The addresses indicated in the FIG. 25 are in HEX representation.

Digital colour space converter

SAA7192A

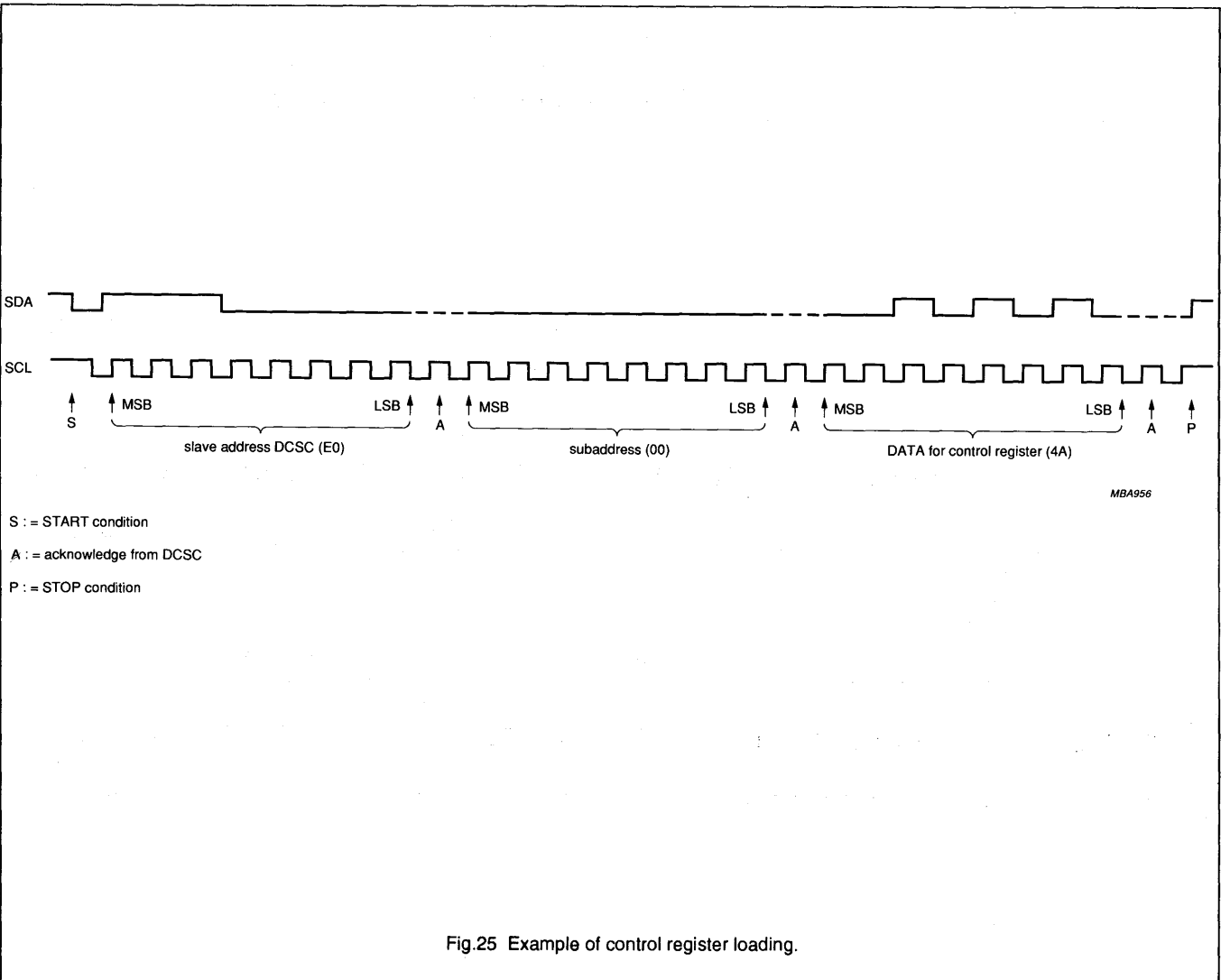

Digital colour space converter

SAA7192A

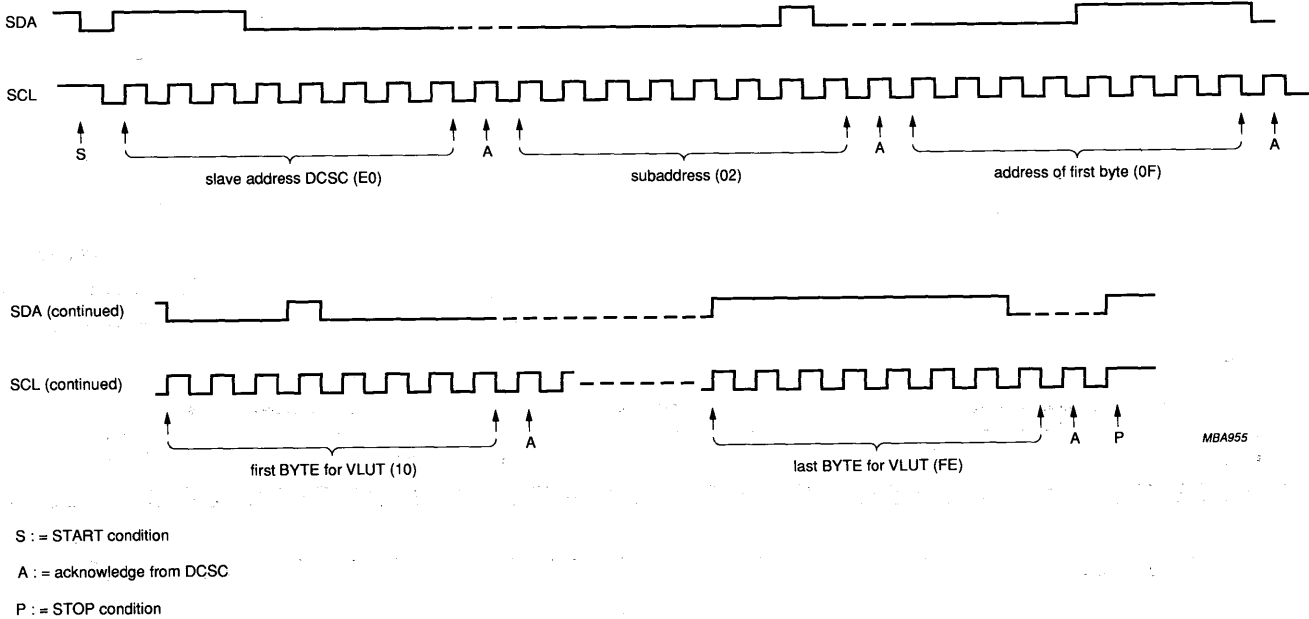

MBA955

In this example the second RAM (GREEN) receives new data at the start of address 0F.  
 The VLUT addresses are automatically incremented by writing data via the SDA line.

Fig.26 Example of VLUT loading.

Digital colour space converter

SAA7192A

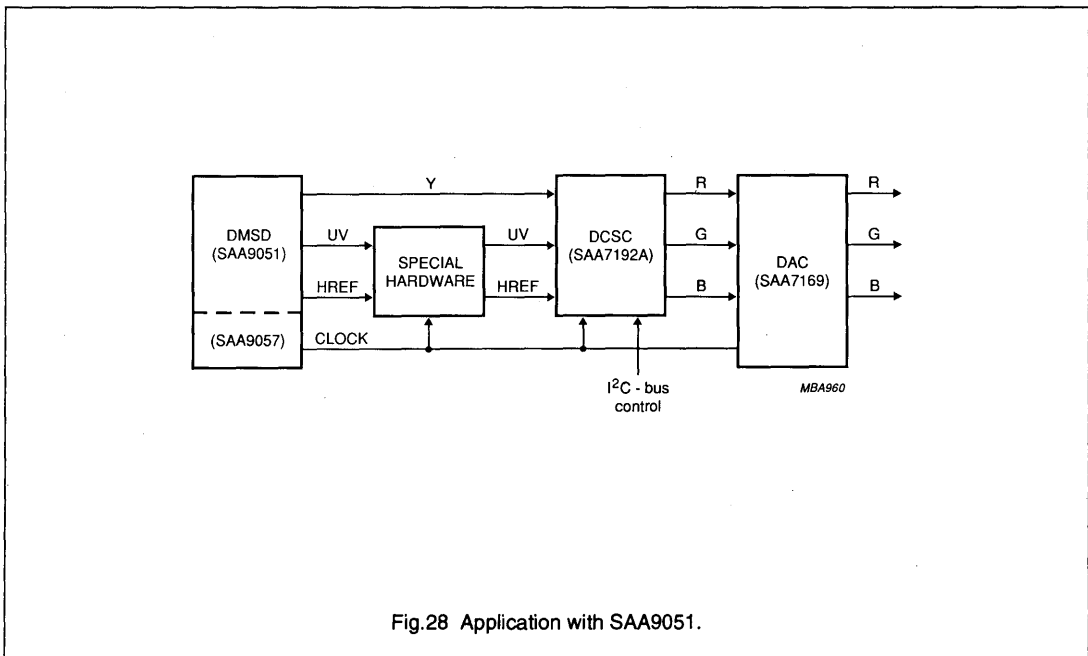
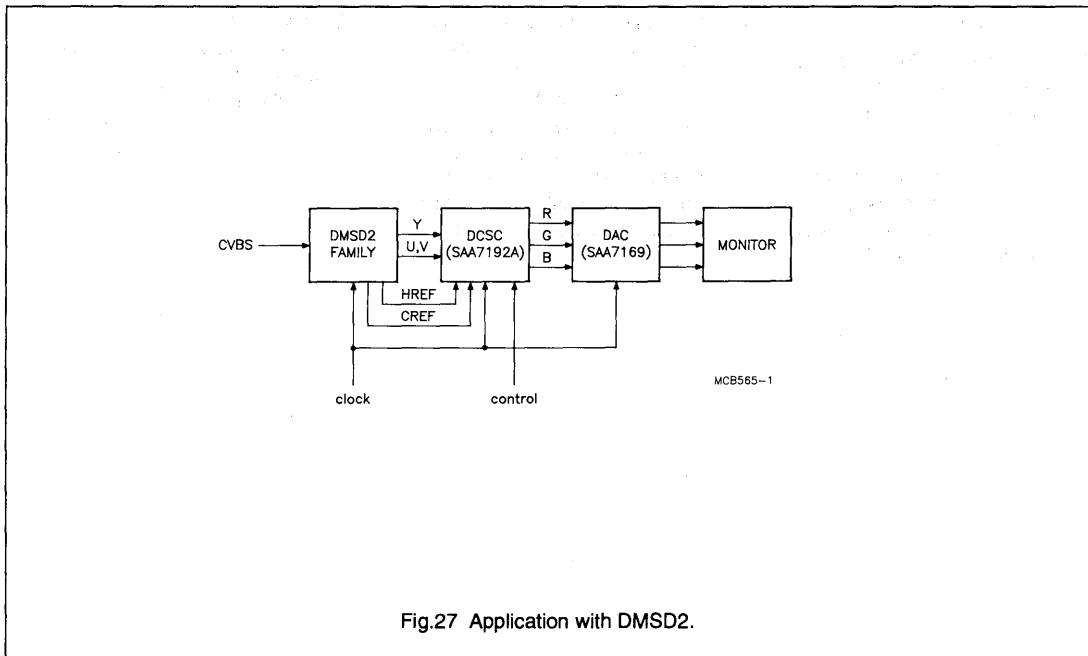

---

## Digital colour space converter

## SAA7192A

---

### APPLICATION

The application is simple since the DCSC is designed to operate in conjunction with the DMSD2 decoder family.

Additional hardware is required to convert the level formats to permit the DCSC to be used with the older 7-bit version of the DMSD.

Due to the differing data formats between the SAA9051 and the SAA7192, the colour difference U and V signals must be converted from two's-complement to unipolar representation and the MSBs of the UV data must be inverted. Differing chrominance amplitudes are small and are not taken into account.

Additionally, the DATAIN10 (LSB of the Y-data) should be connected to ground and the DATAIN34 and DATAIN36 (LSBs of the UV data) should be connected to ground via a resistor to avoid noise at the LSBs.



## Digital colour space converter

SAA7192A

**GLOSSARY**

B	colour component of a video signal (BLUE)
C	coded colour components of a video signal (TV)
Cb	coded colour difference signal (digital B-Y)
CCIR	Comite Consultatif International de Radiocommunication (International Radio Consultative Committee)
CDS-System	Chip Design System
CGC	Clock Generation Circuit
CLUT	Colour Look Up Table (personal computer graphics)
Cr	coded colour difference signal (digital R-Y)
CREF	Clock Reference Signal; indicates the valid data samples of the DMSD
CVBS	Composite Video Burst Synchron signal (TV)
DCSC	Digital Colour Space Converter; converts the YUV signal to RGB
DIN	Deutsches Institut fuer Normung, Berlin
DMSD	family of Digital Multi-standard Decoders, decodes YUV out of the CVBS signal.
G	colour component of a video signal (GREEN)
HDTV	High Definition Television
HREF	Horizontal Line Reference signal
I <sup>2</sup> C-bus	Inter-IC-Bus (Valvo network concept between controllers)
IRT	Institut fuer RundfunkTechnik (Muenchen)
IIC-DVP/SE	Philips Components RHW Hamburg, Department Industrial-ICs Video Products System Engineering
MIC-SE	Philips Components RHW Hamburg, Department MOS-ICs System Engineering (now called IIC-DVP-SE)
RGB	components of a video signal (red, green, blue)
R	colour component of a video signal (RED)
SCL	clock line of the I <sup>2</sup> C-bus
SDA	data line of the I <sup>2</sup> C-bus
SRC	Sample Rate Converter
Semiparallel	Chrominance data (multiplexed colour difference) parallel to luminance data
SERInet	Signetics Elcoma Research ISA Network (Philips computer interconnection network)
VLUT	Video Look Up Table. RAM to multiply video data with a factor
Y	luminance signal (brightness of a video signal)
YUV Bus	Component bus of the DMSD family
U	colour difference signal (coded video signal B-Y)
V	colour difference signal (coded video signal R-Y)

# Digital video decoder and scaler circuit (DESC)

# SAA7194

## FEATURES

- Digital 8-bit luminance input (video (Y) or CVBS)
- Digital 8-chrominance input (CVBS or C from CVBS, Y/C, S-Video (S-VHS or Hi8))
- Luminance and chrominance signal processing for main standards PAL, NTSC and SECAM
- Horizontal and vertical sync detection for all standards
- User programmable luminance peaking for aperture correction
- Compatible with memory-based features (line-locked clock, square pixel)
- Cross colour reduction by chrominance comb filtering for NTSC or special cross-colour cancellation for SECAM
- UV signal delay lines for PAL to correct chrominance phase errors
- Square-pixel format with 768/640 active samples per line
- The bidirectional Expansion Port (YUV-bus) supports data rates of  $780 \times f_H$  (NTSC) and  $944 \times f_H$  (PAL, SECAM) in 4:2:2 format
- Brightness, contrast, hue and saturation controls for scaled outputs
- Down-scaling of video windows with 1023 active samples per line and 1023 active lines per frame to randomly sized windows
- 2D data processing for improved signal quality of scaled luminance data, especially for compression applications
- Chroma key ( $\alpha$ -generation)

- YUV to RGB conversion including Anti-gamma ROM tables for RGB
- 16-word FIFO register for 32-bit output data
- Output configurable for 32/24/16-bit video data bus
- Scaled 16-bit 4:2:2 YUV output
- Scaled 15-bit RGB (5-5-5+ $\alpha$ ) and 24-bit (8-8-8+ $\alpha$ ) output
- Scaled 8-bit monochrome output
- Line increment, field sequence (off/even, interlace/non-interlace) and vertical reset control for easy memory interfacing
- Output of discontinuous data bursts of scaled video data or continuous data output with corresponding qualifier signals
- Real-time status information
- I<sup>2</sup>C-bus control
- Only one crystal of 26.8MHz

## DESCRIPTION

The CMOS circuit SAA7194, digital video decoder and scaler (DESC), is a highly integrated circuit for Desktop Video applications. It combines the functions of a digital video scaler (SAA7186).

The decoder is based on the principle of line-locked clock decoding. It runs at square-pixel frequencies to achieve correct aspect ratio.

Monitor controls are provided to ensure best display. Four data ports are supported:

Ports CVBS(7-0) and CHR(7-0) of the input interface are used in Y/C mode (Fig.1(a)) to

decode digitized luminance and chrominance signals (digitized in two external ADCs).

In normal mode, the CVBS(7-0) input is only used, and only one ADC is necessary. The 32-bit VRAM output port is interface to the video memory; it outputs the down-scaled video data. Different formats and operation modes are supported by this circuit.

The 16-bit wide Expansion Port is a bidirectional port. In general, it establishes the digital YUV as known from the SAA71x1 family of digital decoders. In addition, the Expansion port is configurable to send data from the decoder unit or to accept external data from input into the scaler. In input mode the clock rate and/or the sync signals may be delivered by the external data source.

Decoder and scaler units can run at different clock rates. The decoder processing always operates with a line locked clock (LLC). This clock is derived from the CVBS signal and is suited best for memory based video processing; the LLC clock is always present the scaler clock may be driven by the LLC clock or by an external clock depending on the configuration of the Expansion port.

The circuit is I<sup>2</sup>C-bus-controlled. The I<sup>2</sup>C-bus interface is clocked by LLC to ensure proper control.

The I<sup>2</sup>C-bus control is divided into two sections:

- subaddress 00h to 1F for the decoder part
- subaddress 20h to 3F for the scaler part

The programming of the subaddresses for the scaler part becomes effective at the first vertical sync pulse VS after a transmission.

## ORDERING INFORMATION

EXTENDED TYPE NUMBER	PACKAGE			
	PINS	PIN POSITION	MATERIAL	CODE
SAA7194	120	QFP	plastic	SOT349 AA1

SAA7194 is a subset of SAA7196. In SAA7194, the internal CGC function is not available. Therefore, the pins 36, 37, 38 40 and 42 are defined differently, as shown in the following table:

SIGNAL NAME	PIN NUMBER	SAA7194	SAA7196	
RESN	36	I	O	
CGCE	37	I I = LOW needs to be grounded	if grounded (LOW) ⇒ internal CGC is disabled IC functions like SAA7194	if pulled up (HIGH) ⇒ internal CGC is enabled full-function SAA7196
CREF	38	I	I	O
LLC	40	I	I	O
LLC2	42	O (reserved)	O	

# Digital video decoder and scaler circuit (DESC)

SAA7194

For further specification on SAA7194, please refer to datasheet SAA7196, Figure 1(a) and Figure 34 are slightly different for SAA7194, and are shown as follows:

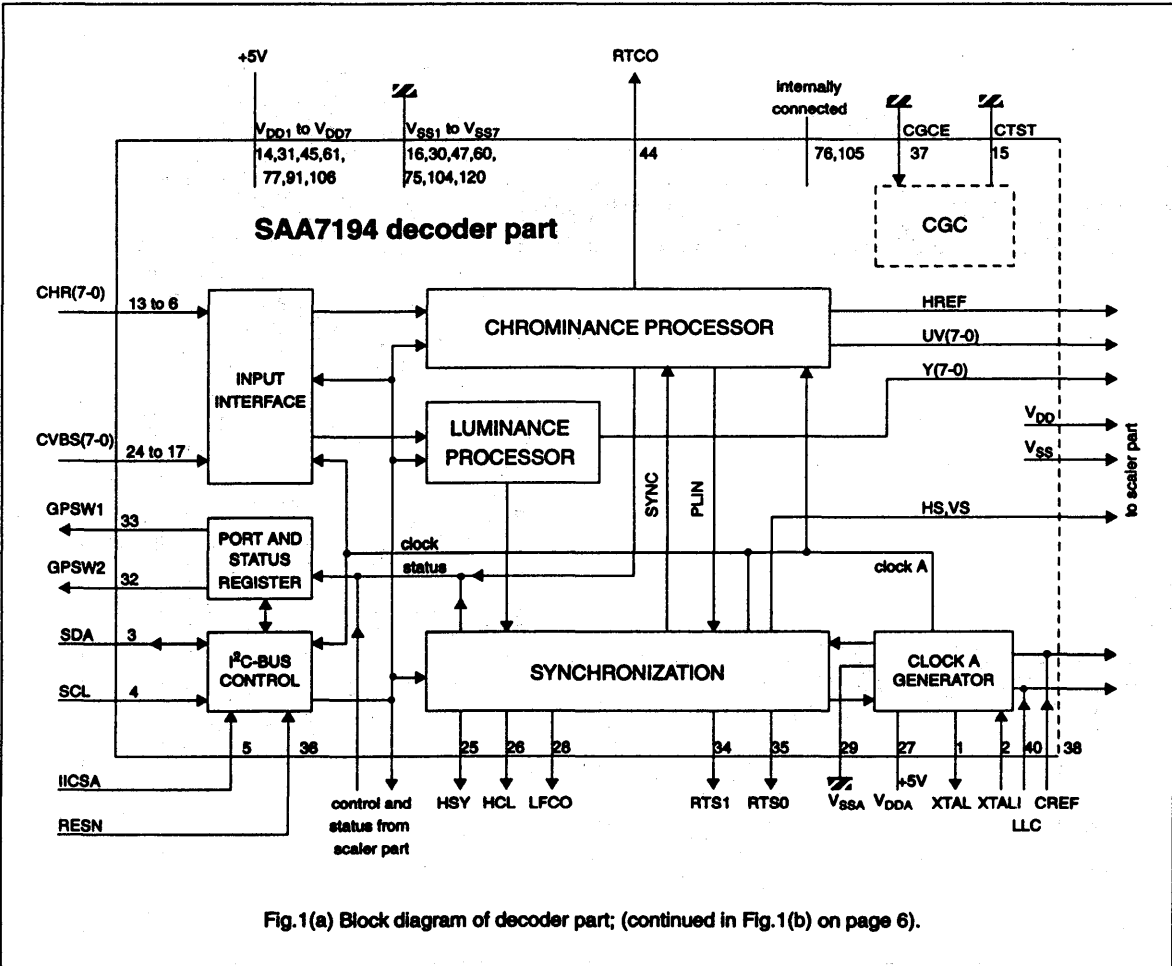

Fig.1(a) Block diagram of decoder part; (continued in Fig.1(b) on page 6).

# Digital video decoder and scaler circuit (DESC)

# SAA7194

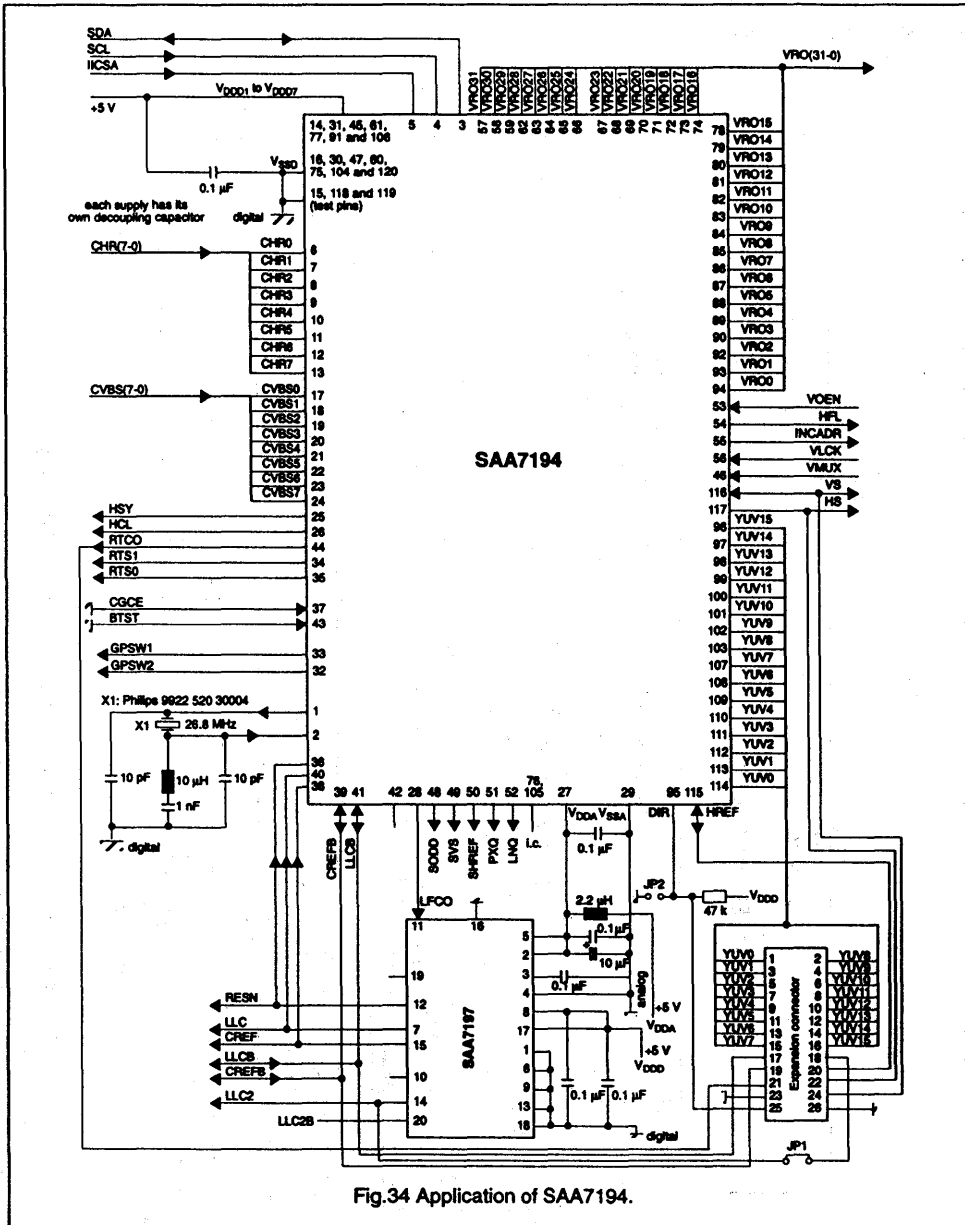

Fig.34 Application of SAA7194.

# Digital video decoder, scaler, and clock generator (DESCPro)

## SAA7196

### 1. FEATURES

- Digital 8-bit luminance input (video (Y) or CVBS)
- Digital 8-bit chrominance input (CVBS or C from CVBS, Y/C, S-video (S-VHS or Hi8))
- Luminance and chrominance signal processing for main standards PAL, NTSC and SECAM
- Horizontal and vertical sync detection for all standards
- User programmable luminance peaking for aperture correction
- Compatible with memory-based features (line-locked clock, square pixel)
- Cross colour reduction by chrominance comb filtering for NTSC or special cross-colour cancellation for SECAM
- UV signal delay lines for PAL to correct chrominance phase errors
- Square-pixel format with 768/640 active samples per line
- The bidirectional Expansion Port (YUV-bus) supports data rates of  $780 \times f_H$  (NTSC) and  $944 \times f_H$  (PAL, SECAM) in 4:2:2 format
- Brightness, contrast, hue and saturation controls for scaled outputs
- Down-scaling of video windows with 1023 active samples per line and 1023 active lines per frame to randomly sized windows
- 2D data processing for improved signal quality of scaled luminance data, especially for compression applications
- Chroma key ( $\alpha$ -generation)
- YUV to RGB conversion including Anti-gamma ROM tables for RGB
- 16-word output FIFO (32-bit words)
- Output configurable for 32/24/16-bit video data bus
- Scaled 16-bit 4:2:2 YUV output
- Scaled 15-bit RGB (5-5-5+ $\alpha$ ) and 24-bit (8-8-8+ $\alpha$ ) output
- Scaled 8-bit monochrome output
- Line increment, field sequence (odd/even, interlace/non-interlace) and vertical reset control for easy memory interfacing
- Output of discontinuous data bursts of scaled video data or continuous data output with corresponding qualifier signals
- Real-time status information
- I<sup>2</sup>C-bus control
- Only one crystal of 26.8 MHz
- Clock generator on chip

### 2. GENERAL DESCRIPTION

The CMOS circuit SAA7196, digital video decoder, scaler and clock generator (DESCPro), is a highly integrated circuit for DeskTop Video applications. It combines the functions of a digital multistandard decoder (SAA7191B), a digital video scaler (SAA7186) and a clock generator (SAA7197).

The decoder is based on the principle of line-locked clock decoding. It runs at square-pixel frequencies to achieve correct aspect ratio.

Monitor controls are provided to ensure best display. Four data ports are supported:

Ports CVBS(7-0) and CHR(7-0) of the input interface are used in Y/C mode (Fig.1(a) on page 5) to decode digitized luminance and chrominance signals (digitized in two external ADCs).

In normal mode, the CVBS(7-0) input is only used, and only one ADC is necessary (Fig.3 on page 12). The 32-bit VRAM output port is interface to the video memory; it outputs the down-scaled video data. Different formats and operation modes are supported by this circuit.

The 16-bit wide Expansion Port is a bidirectional port. In general, it establishes the digital YUV as known from the SAA 71x1 family of digital decoders. In addition, the Expansion port is configurable to send data from the decoder unit or to accept external data for input into the scaler. In input mode the clock rate and/or the sync signals may be delivered by the external data source.

Decoder and scaler units can run at different clock rates. The decoder processing always operates with a line locked clock (LLC). This clock is derived from the CVBS signal and is suited best for memory based video processing; the LLC clock is always present. The scaler clock may be driven by the LLC clock or by an external clock depending on the configuration of the Expansion port.

The circuit is I<sup>2</sup>C-bus-controlled. The I<sup>2</sup>C-bus interface is clocked by LLC to ensure proper control. The I<sup>2</sup>C-bus control is identical to that of SAA7194. It is divided into two sections:

- subaddress 00h to 1F for the decoder part (Tables 9 and 10)
- subaddress 20h to 3F for the scaler part (Tables 11 and 12)

The programming of the subaddresses for the scaler part becomes effective at the first vertical sync pulse VS after a transmission.

# Digital video decoder, scaler, and clock generator (DESCPro)

SAA7196

### 3. QUICK REFERENCE DATA

SYMBOL	PARAMETER	MIN.	TYP.	MAX.	UNIT
$V_{DD}$	supply voltage	4.5	5	5.5	V
$I_{DD\ tot}$	total supply current	-	180	280	mA
$V_I$	data input level	TTL-compatible			
$V_O$	data output level	TTL-compatible			
LLC	input clock frequency	-	-	32	MHz
$T_{amb}$	operating ambient temperature range	0	-	70	$^{\circ}C$

### 4. ORDERING INFORMATION

EXTENDED TYPE NUMBER	PACKAGE			
	PINS	PIN POSITION	MATERIAL	CODE
SAA7196	120	QFP	plastic	SOT349 AA1

Digital video decoder, scaler and clock generator circuit (DESCPro)

SAA7196

5. BLOCK DIAGRAM

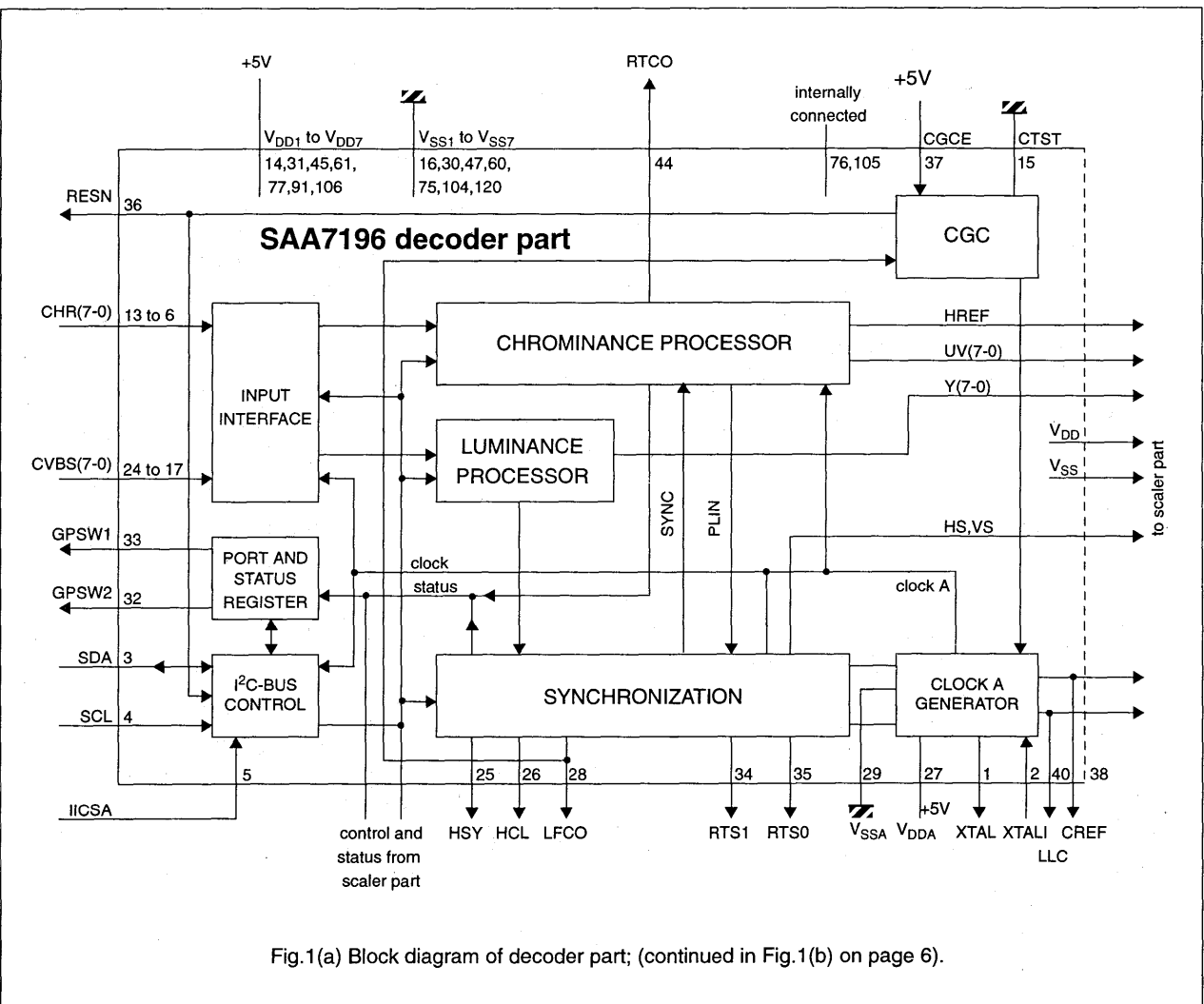

Fig.1(a) Block diagram of decoder part; (continued in Fig.1(b) on page 6).





# Digital video decoder, scaler and clock generator circuit (DESCPro)

SAA7196

## 6. PINNING

SYMBOL	PIN	STATUS	DESCRIPTION
XTAL	1	O	26.8 MHz crystal oscillator output, not used if TTL clock signal is used
XTALI	2	I	26.8 MHz crystal oscillator input or external clock input (TTL, squarewave)
SDA	3	I/O	I <sup>2</sup> C-bus data line
SCL	4	I	I <sup>2</sup> C-bus clock line
IICSA	5	I	I <sup>2</sup> C-bus set address
CHRO	6	I	digital chrominance input signal (bits 0 to 7)
CHR1	7	I	
CHR2	8	I	
CHR3	9	I	
CHR4	10	I	
CHR5	11	I	
CHR6	12	I	
CHR7	13	I	
V <sub>DD1</sub>	14	-	+5V supply voltage 1
CTST	15	-	connected to ground (clock test pin)
V <sub>SS1</sub>	16	-	GND1 (0V)
CVBS0	17	I	digital CVBS input signal (bits 0 to 7)
CVBS1	18	I	
CVBS2	19	I	
CVBS3	20	I	
CVBS4	21	I	
CVBS5	22	I	
CVBS6	23	I	
CVBS7	24	I	
HSY	25	O	horizontal sync indicator output (programmable)
HCL	26	O	horizontal clamping pulse output (programmable)
V <sub>DDA</sub>	27	-	+5V analog supply voltage
LFCO	28	O	line frequency control output signal to CGC (multiple of present line frequency)
V <sub>SSA</sub>	29	-	analog ground (0V)
V <sub>SS2</sub>	30	-	GND2 (0V)

# Digital video decoder, scaler and clock generator circuit (DESCPro)

SAA7196

SYMBOL	PIN	STATUS	DESCRIPTION
V <sub>DD2</sub>	31	-	+5V supply voltage 2
GPSW2	32	O	general purpose output 2 (settable via I <sup>2</sup> C-bus)
GPSW1	33	O	general purpose output 1 (settable via I <sup>2</sup> C-bus)
RTS1	34	O	real time status output 1; controlled by RTSE-bit
RTS0	35	O	real time status output 0; controlled by RTSE-bit
RESN	36	O	reset output, active low
CGCE	37	I	enable input for internal CGC (connected to +5V)
CREFB	38	O	clock qualifier output (test only)
CREFB	39	I/O	clock reference qualifier input/output (HIGH indicates valid data on Expansion port)
LLC	40	O	line-locked video system clock output, for frontend (ADC's) only; frequency: 1888*f <sub>H</sub> for 50Hz/625 lines per field systems and 1560*f <sub>H</sub> for 60 Hz/525 lines per field systems
LLCB	41	I/O	line-locked clock signal input/output, maximum 32 MHz (twice of pixel rate in 4:2:2); frequency: 1888*f <sub>H</sub> for 50Hz/625 lines per field systems and 1560*f <sub>H</sub> for 60 Hz/525 lines per field systems; or variable input clock up to 32 MHz in input mode
LLC2	42	O	line-locked clock signal output (pixel clock)
BTST	43	I	connected to ground; BTST = HIGH sets all outputs (except pins 1,28, 38, 40 and 42) to high-impedance state (testing)
RTCO	44	O	real time control output
V <sub>DD3</sub>	45	I	+5V supply voltage 3
VMUX	46	I	VRAM output multiplexing, control input for the 32- to 16-bit multiplexer (Table 4 on page 23)
V <sub>SS3</sub>	47	-	GND3 (0V)
SODD	48	O	odd/even field sequence reference output related to the scaler output (test only)
SVS	49	O	vertical sync signal related to the scaler output (test only)
SHREF	50	O	delayed HREF signal related to the scaler output (test only)
PXQ	51	O	pixel qualifier output signal to mark active pixels of a qualified line (polarity: QPP-bit; test only)
LNQ	52	O	line qualifier output signal to mark active video phase (polarity: QPP-bit; test only)
VOEN	53	I	enable input of VRAM output
HFL	54	O	FIFO half-full flag output signal
INCADR	55	O	line increment / vertical reset control output
VCLK	56	I	clock input signal of FIFO output
VRO31	57	O	32-bit digital VRAM output port (bits 31 to 29)
VRO30	58	O	
VRO29	59	O	
V <sub>SS4</sub>	60	-	GND4 (0V)

# Digital video decoder, scaler and clock generator circuit (DESCPro)

SAA7196

SYMBOL	PIN	STATUS	DESCRIPTION
V <sub>DD4</sub>	61	-	+5 V supply voltage 4
VRO28	62	O	32-bit VRAM output port (bits 28 to 16)
VRO27	63	O	
VRO26	64	O	
VRO25	65	O	
VRO24	66	O	
VRO23	67	O	
VRO22	68	O	
VRO21	69	O	
VRO20	70	O	
VRO19	71	O	
VRO18	72	O	
VRO17	73	O	
VRO16	74	O	
V <sub>SS5</sub>	75	-	GND5 (0V)
i.c.	76	-	internally connected
V <sub>DD5</sub>	77	-	+5V supply voltage 5
VRO15	78	O	32-bit VRAM output port (bits 15 to 3)
VRO14	79	O	
VRO13	80	O	
VRO12	81	O	
VRO11	82	O	
VRO10	83	O	
VRO9	84	O	
VRO8	85	O	
VRO7	86	O	
VRO6	87	O	
VRO5	88	O	
VRO4	89	O	
VRO3	90	O	

# Digital video decoder, scaler and clock generator circuit (DESCPro)

SAA7196

SYMBOL	PIN	STATUS	DESCRIPTION
V <sub>DD6</sub>	91	-	+5V supply voltage 6
VRO2	92	O	32-bit VRAM output port (bits 2 to 0)
VRO1	93	O	
VRO0	94	O	
DIR	95	I	direction control of Expansion Bus
YUV15	96	I/O	digital 16-bit video input/output signal (bits 15 to 8): luminance (Y)
YUV14	97	I/O	
YUV13	98	I/O	
YUV12	99	I/O	
YUV11	100	I/O	
YUV10	101	I/O	
YUV9	102	I/O	
YUV8	103	I/O	
V <sub>SS6</sub>	104	-	GND6 (0V)
i.c.	105	-	internally connected
V <sub>DD7</sub>	106	-	+5V supply voltage 7
YUV7	107	I/O	digital 16-bit video input/output signal (bits 7 to 0): colour-difference signals (UV)
YUV6	108	I/O	
YUV5	109	I/O	
YUV4	110	I/O	
YUV3	111	I/O	
YUV2	112	I/O	
YUV1	113	I/O	
YUV0	114	I/O	
HREF	115	I/O	horizontal reference signal
VS	116	I/O	vertical sync input/output signal with respect to the YUV input signal
HS	117	O	horizontal sync signal, programmable
AP	118	I	connected to ground (action pin for testing)
SP	119	I	connected to ground (shift pin for testing)
V <sub>SS7</sub>	120	-	GND7 (0V)

# Digital video decoder, scaler and clock generator circuit (DESCPro)

## SAA7196

### PIN CONFIGURATION

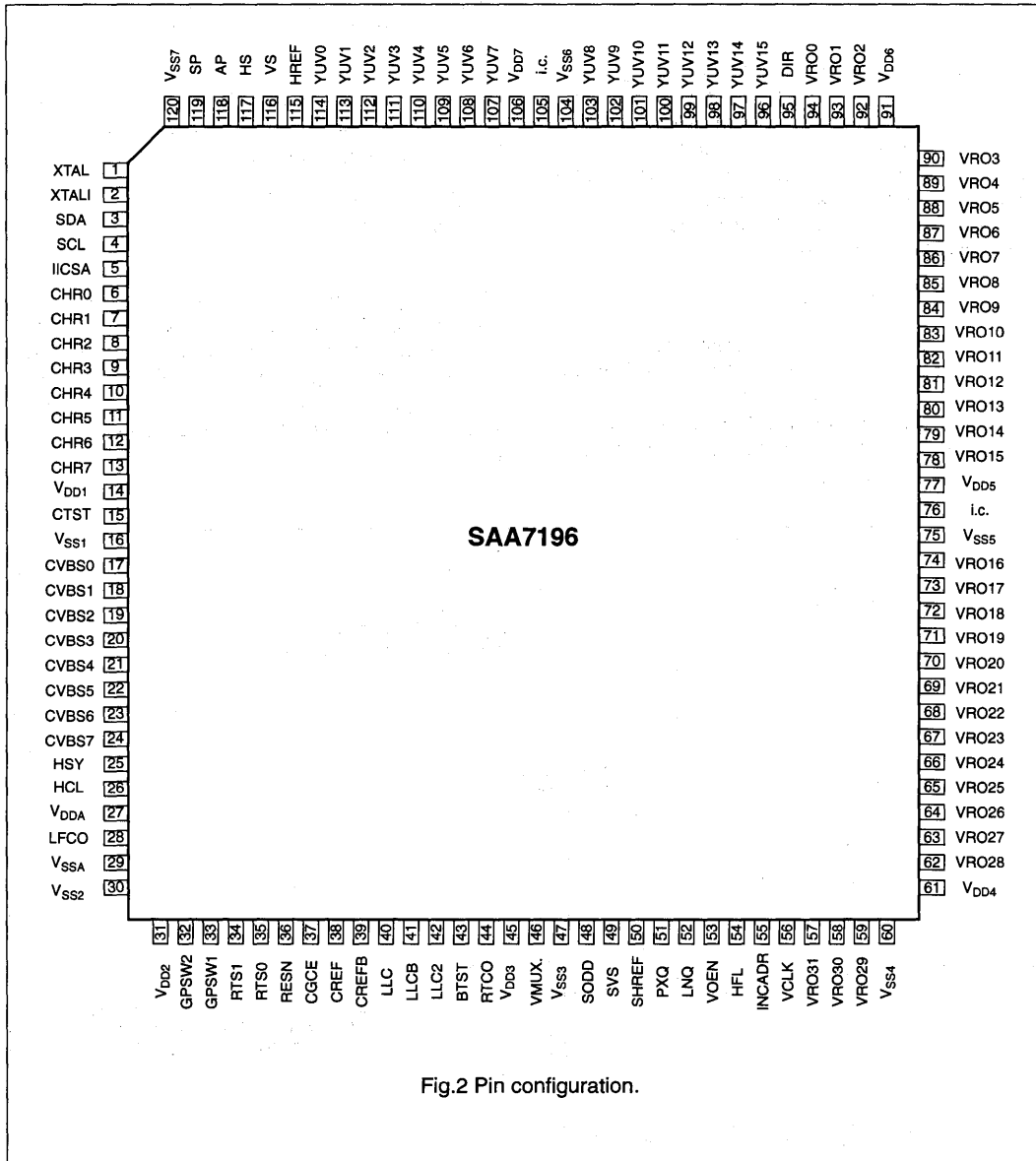

Fig.2 Pin configuration.

# Digital video decoder, scaler and clock generator circuit (DESCPro)

SAA7196

## 7. FUNCTIONAL DESCRIPTION

### 7.1. FUNCTIONAL DESCRIPTION DECODER PART

PAL, NTSC and SECAM standard colour signals based on line-locked clock are decoded (Fig.25 on page 41). In Y/C mode (Fig.1(a) on page 5), digitized luminance CVBS(7-0) and chrominance CHR(7-0) signals - digitised in two external ADCs - are input. In normal mode only CVBS(7-0) is used. The data rate is 29.5 MHz (50 MHz systems) or 24.54 MHz (60 MHz systems).

#### Chrominance processor

The input signal passes the input interface, the chrominance bandpass filter to eliminate DC components, and is finally fed to the multiplier inputs of a quadrature demodulator, where two subcarrier signals (0° and 90° phase-shifted) from a local digital oscillator (DTO1) are applied.

The frequency is dependent on the present colour standard. The signals are low-pass filtered and amplified in a gain-controlled amplifier. A final low-pass stage provides a correct bandwidth performance.

PAL signals are comb-filtered to eliminate crosstalk between the chrominance channels according to PAL standard requirements.

NTSC signals are comb-filtered to eliminate crosstalk from luminance to chrominance for vertical structures.

SECAM signals are fed through a cloche filter, a phase demodulator and a differentiator to achieve proportionality to the instantaneous frequency. The signals are de-multiplexed in the SECAM recombination stage after passing a de-emphasis stage to provide the two serially transmitted colour-difference signals.

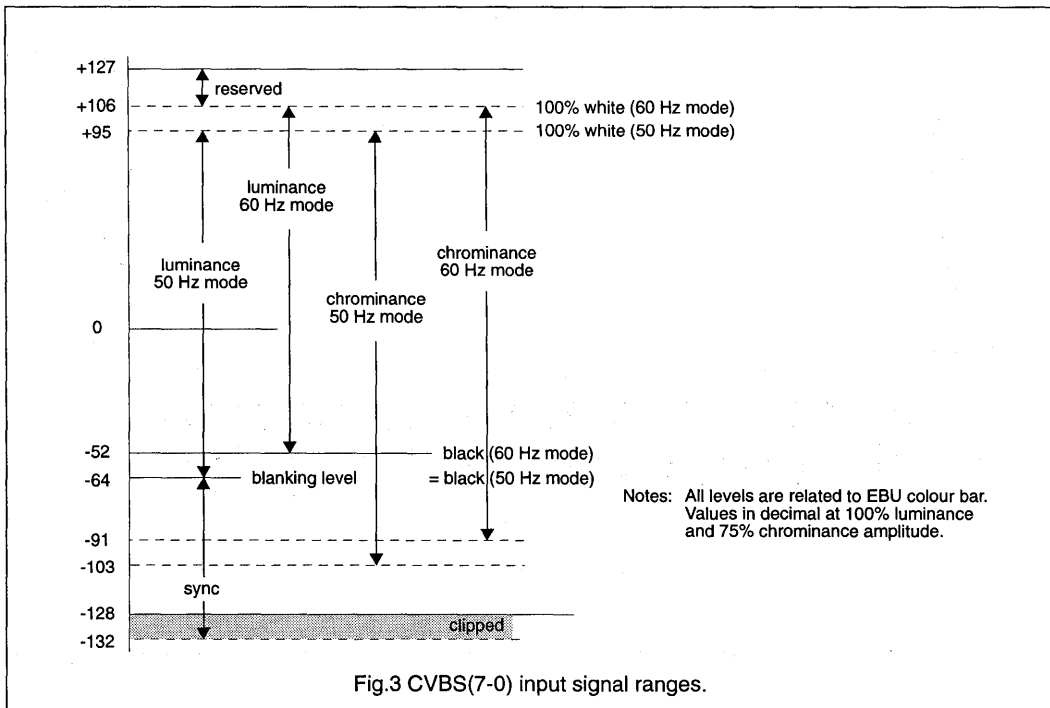

# Digital video decoder, scaler and clock generator circuit (DESCPro)

**SAA7196**

The PLL for quadrature demodulation is closed via the cloche filter (to improve noise performance), a phase demodulator, a burst gate accumulator, a loop filter PI1 and a discrete time oscillator DTO1. The gain control loop is closed via the cloche filter, amplitude detector, a burst gate accumulator and a loop filter PI2.

The sequence processor switches signals according to standards.

## Luminance processor

The data rate of the input signal is reduced to LLC2 frequency by a sample rate converter in the input interface. The high frequency components are emphasized in a prefilter to compensate for losses in the succeeding chrominance trap. The chrominance trap is adjusted to a center frequency of 3.58 MHz (NTSC) or 4.4 MHz (PAL, SECAM) to eliminate most of the colour carrier components. The chrominance trap is bypassed for S-VHS signals. The high frequency components in the luminance signal are "peaked" using a bandpass filter and a coring stage. The "peaked" (high frequent) component is added to the "unpeaked" signal part for sharpness improvement and output via variable delay to the Expansion-Bus.

## Synchronization

The sync input signal is reduced in bandwidth to 1 MHz before it is sliced and separated from luminance signal. The sync pulses are compared in a detector with the divided clock signal of a counter. The resulting output signal is fed to a loop filter that accumulates all the phase deviations. Thereby, a discrete time oscillator DTO2 is driven generating the line frequency control signal LFCO. An external PLL generates the line-locked clock LLC from the signal LFCO.

A noise-limited vertical deflection pulse is generated for vertical processing that also inserts artificial pulses if vertical input pulses are missing. 50/60 Hz as well as odd/even field is automatically detected by the identification stage.

## 7.2. FUNCTIONAL DESCRIPTION

### EXPANSION PORT (Fig.1(b) on page 6)

The Expansion port is a bidirectional interface for digital video signals YUV(15-0) in 4:2:2 format (Table 2 on page 15). External video signals can be inserted to the scaler or decoded video signals of the decoder part can be output.

The data direction is controlled by pin 95 (DIR=HIGH: data from external; Table 1 on page 14).

YUV(15-0), HREF, VS, LLCB and CREFB pins are input when bits OECL, OEHV, OEYC of subaddress 0E are set to "0". Different modes are provided (timing see Figures 5 and 6 on page 16 and page 17):

#### Mode 0:

All bidirectional terminals are outputs. The signal of the decoder part (internal YUV(15-0)) is switched to be scaled.

#### Mode1:

External YUV(15-0) is input to the scaler. LLCB/CREFB clock system and HREF/VS from the SAA7196 are used to control the external source. It is possible to switch between Mode 0 and Mode 1 by means of DIR input (Fig.4 on page 15). Pixelwise switching of the scaler source is possible because the internal clock and sync sources are used.

#### Mode 2:

External YUV(15-0) is input to the scaler. LLCB/CREFB clock system and HREF/VS from external are used.

#### Mode 3:

YUV(15-0) and HREF/VS terminals are inputs. External YUV(15-0) is input to the scaler with HREF/VS reference from external. LLCB/CREFB clock system of the SAA7196 is used.

# Digital video decoder, scaler and clock generator circuit (DESCPro)

SAA7196

## 7.3. MONITOR CONTROLS

(BCS; Fig.1(b) on page 6)

### BRIGHTNESS AND CONTRAST CONTROLS:

The luminance signal can be controlled via I<sup>2</sup>C-bus (Table 9 on page 32) by the bits BRIG(7-0) and CONT(6-0).

Brightness control:	value
00 (hex)	minimum offset
80 (hex)	CCIR level
FF (hex)	maximum offset

Contrast control:	value
00 (hex)	luminance off
40 (hex)	CCIR level
7F (hex)	1.9999 amplitude

### SATURATION CONTROL:

the chrominance signal can be controlled via I<sup>2</sup>C-bus (Table 9 on page 32) by the bits SAT(6-0) and HUE(7-0).

Saturation control:	value
00 (hex)	colour off
40 (hex)	CCIR level
7F (hex)	1.9999 amplitude

### Clipping:

All resulting output values are clipped to minimum (equals 1) and maximum (equals 254).

**Table 1** Operation modes

MODE	I <sup>2</sup> C BIT			DIR PIN 95	INPUT SOURCE				
	OEYC	OEHV	OECL		YUV	HREF	VS	LLCB	CREFB
0	1	1	1	LOW	0	0	0	0	0
1	X	1	1	HIGH	1	0	0	0	0
2	X	0	0	HIGH	1	1	1	1	1
3	X	0	1	HIGH	1	1	1	0	0

X = don't care; 1 = input to monitor control/scaler; 0 = output from decoder



# Digital video decoder, scaler and clock generator circuit (DESCPro)

SAA7196

Table 2 YUV-bus format on Expansion Port

PIN	SIGNALS ON EXPANSION PORT (PIXEL BYTE SEQUENCE ON PINS)				
YUV15	Ye7	Yo7	Ye7	Yo7	Ye7
YUV14	Ye6	Yo6	Ye6	Yo6	Ye6
YUV13	Ye5	Yo5	Ye5	Yo5	Ye5
YUV12	Ye4	Yo4	Ye4	Yo4	Ye4
YUV11	Ye3	Yo3	Ye3	Yo3	Ye3
YUV10	Ye2	Yo2	Ye2	Yo2	Ye2
YUV9	Ye1	Yo1	Ye1	Yo1	Ye1
YUV8	Ye0	Yo0	Ye0	Yo0	Ye0
YUV7	Ue7	Ve7	Ue7	Ve7	Ue7
YUV6	Ue6	Ve6	Ue6	Ve6	Ue6
YUV5	Ue5	Ve5	Ue5	Ve5	Ue5
YUV4	Ue4	Ve4	Ue4	Ve4	Ue4
YUV3	Ue3	Ve3	Ue3	Ve3	Ue3
YUV2	Ue2	Ve2	Ue2	Ve2	Ue2
YUV1	Ue1	Ve1	Ue1	Ve1	Ue1
YUV0	Ue0	Ve0	Ue0	Ve0	Ue0
Pixel order	n	n+1	n+2	n+3	n+4

e = even pixel number; o = odd pixel number

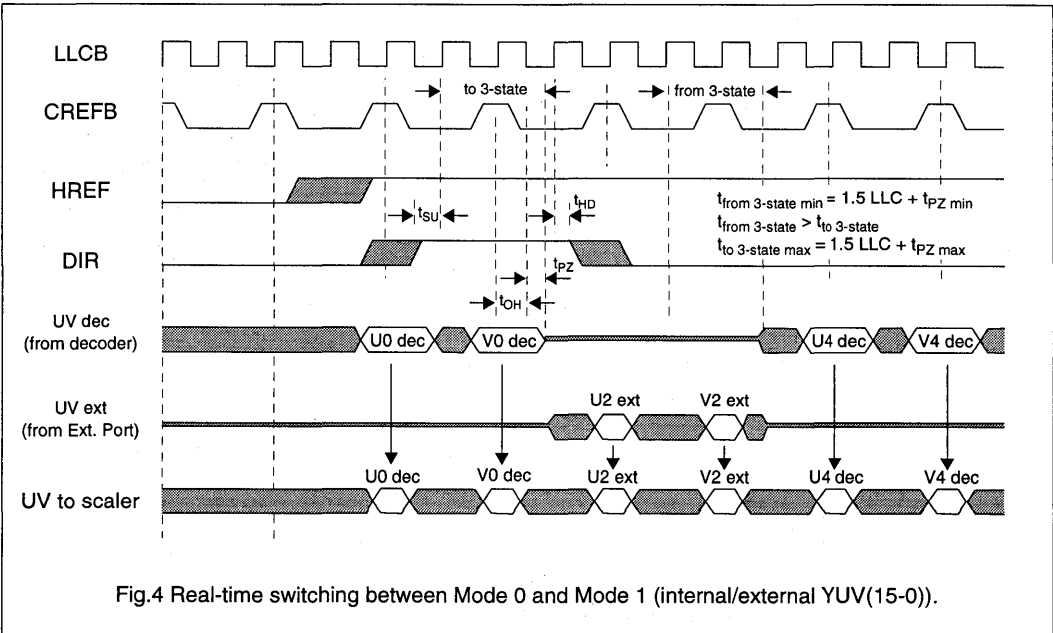

# Digital video decoder, scaler and clock generator circuit (DESCPro)

SAA7196

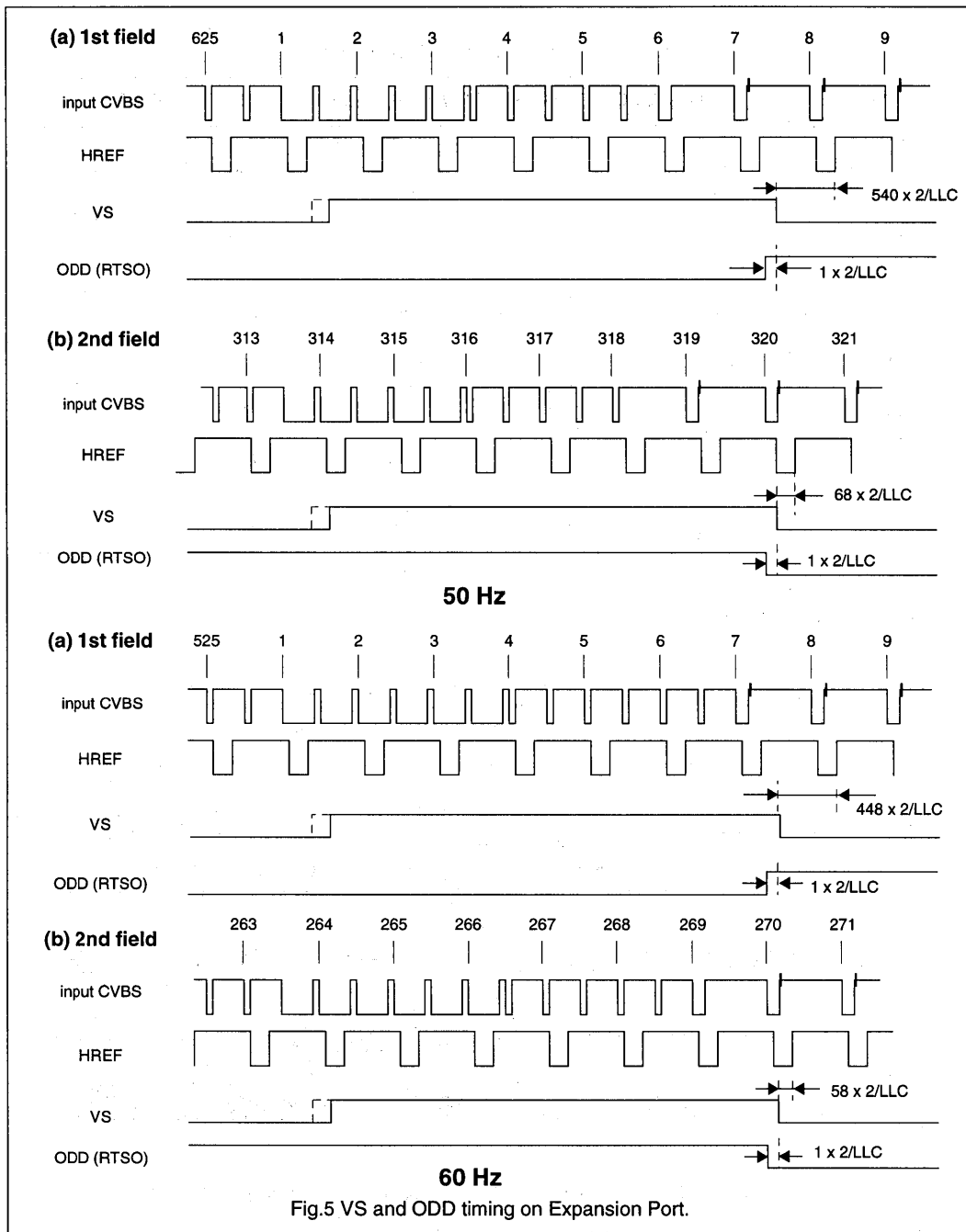

Digital video decoder, scaler  
and clock generator circuit (DESCPro)

SAA7196

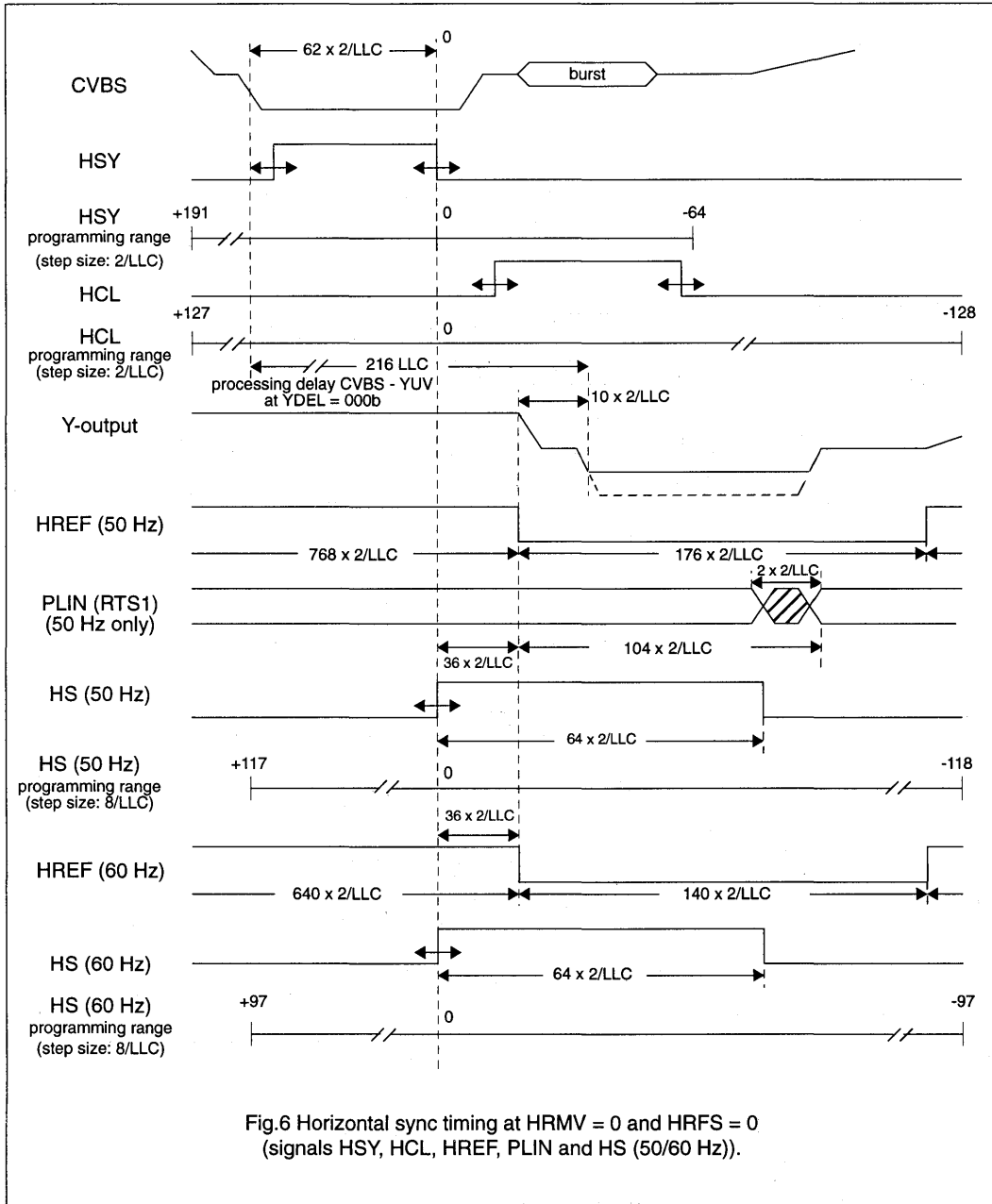

Fig.6 Horizontal sync timing at HRMV = 0 and HRFS = 0 (signals HSY, HCL, HREF, PLIN and HS (50/60 Hz)).

Digital video decoder, scaler  
and clock generator circuit (DESCPro)

SAA7196

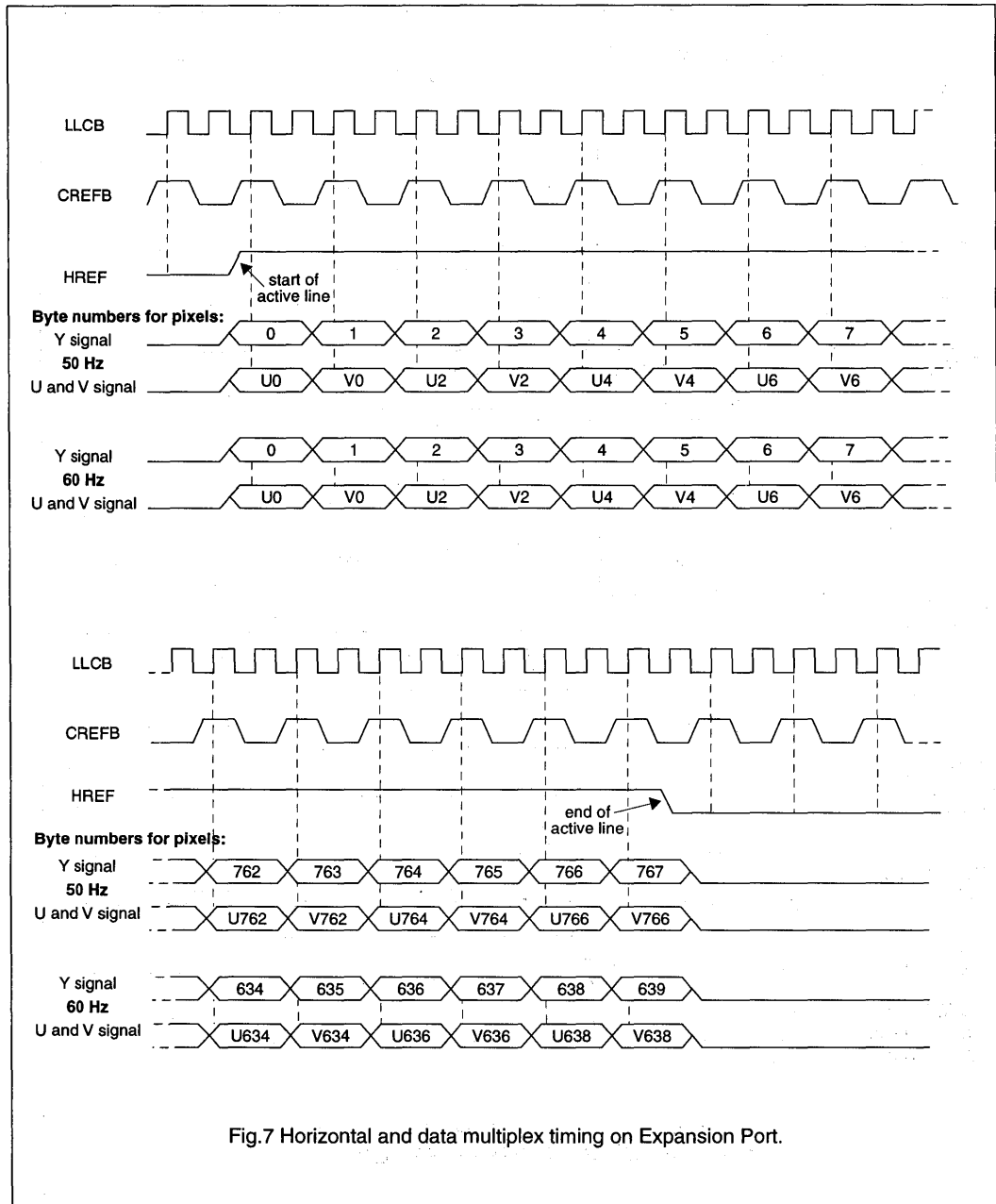
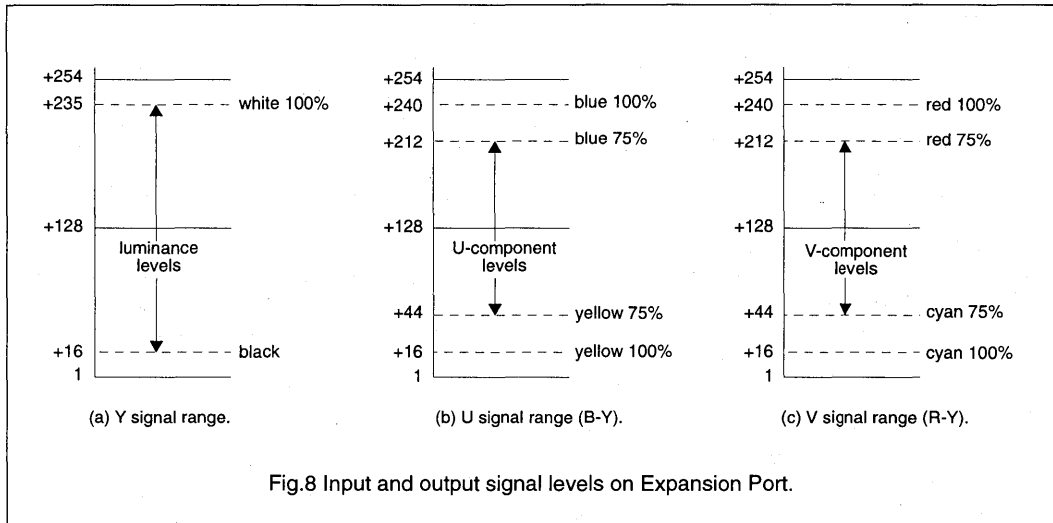

Fig.7 Horizontal and data multiplex timing on Expansion Port.

# Digital video decoder, scaler and clock generator circuit (DESCPro)

SAA7196



### RTCO output (pin 44; Fig.9)

This real-time control and status output signal contains serial information about actual system clock, subcarrier frequency and PAL/SECAM sequence. The signal can be used for various applications in external circuits, e.g. in a digital encoder to achieve "clean" encoding.

### RTS1 and RTS0 outputs (pins 34 and 35)

These outputs can be configured in two modes

dependent on RTSE bit (subaddress 0D).

RTSE = 0: the output RTS0 contains the odd/even field identification bit (HIGH equals odd); output RTS1 contains the inverted PAL/SECAM sequence bit (HIGH equals non-inverted (R-Y)-line/DB-line).

RTSE = 1: the output RTS0 contains the horizontal lock bit (HIGH equals PLL locked); output RTS1 contains the vertical detection bit (HIGH equals vertical sync detected).

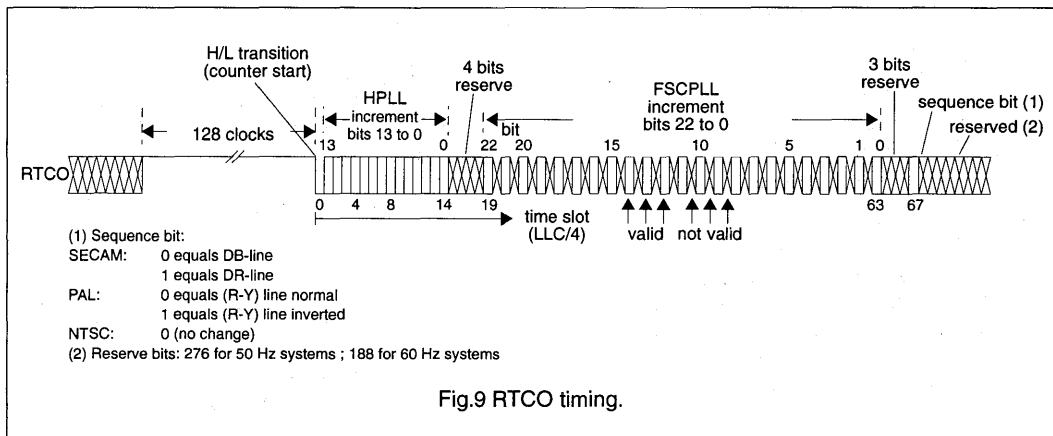

# Digital video decoder, scaler and clock generator circuit (DESCPro)

SAA7196

## 7.4. FUNCTIONAL DESCRIPTION SCALER PART

The scaler part receives YUV(15-0) input data in 4:2:2 format.

The video data from the BCS control are processed in horizontal direction in two separate decimation filters. The luminance component is also processed in vertical direction (VPU\_Y).

Chrominance data are interpolated to a 4:4:4 format; a chroma keying bit is generated.

The 4:4:4 YUV data are then converted from the YUV to the RGB domain in a digital matrix. ROM tables in the RGB data path can be used for anti-gamma correction of gamma-corrected input signals. Uncorrected RGB and YUV signals can be bypassed.

A scale control unit generates reference and gate signals for scaling of the processed video data. After data formatting to the various VRAM port formats, the scaled video data are buffered in the 16 word 32-bit output FIFO register. The scaling is performed by pixel and line dropping at the FIFO input. The FIFO output is directly connected to the VRAM output bus VRO(31-0).

Specific reference signals support an easy memory interfacing.

### Decimation filters

The decimation filters perform accurate horizontal filtering of the input data stream.

The signal bandwidth is matched in front of the pixel decimation stage, thus disturbing artifacts, caused by the pixel dropping, are reduced.

The signal bandwidth can be reduced in steps of (Figures 27 and 28 on page 46):

- 2-tap filter = -6 dB at 0.325 pixel rate
- 3-tap filter = -6 dB at 0.25 pixel rate
- 4-tap filter = -6 dB at 0.21 pixel rate
- 5-tap filter = -6 dB at 0.125 pixel rate
- 9-tap filter = -6 dB at 0.075 pixel rate

The different characteristics are chosen independently by I<sup>2</sup>C-bus control bits HF2 to HF0 when AFS = 0 (Subaddress 28). In the adaptive mode with AFS = 1, the filter characteristics are chosen dependent on the defined sizing parameters (see Table 3).

### Vertical processing (VPU-Y)

Luminance data are fed to a vertical filter consisting of a 384 x 8-bit RAM and an arithmetic block (Fig.1(b) on page 6). Sub-sampling and interpolation operations are applied. The luminance data are processed in vertical direction to preserve the video information for small scaling factors and to reduce artifacts caused by the dropping.

The available modes respectively transfer functions are selectable by bits VP1 and VP0 (subaddress 28). Adaptive modes, controlled by AFS and AFG bits (subaddresses 28 and 30) are also available (see Table 3).

**Table 3** Adaptive filter selection (AFS = 1)

scaling ratio	filter function (refer to I <sup>2</sup> C section)
XD/XS	horizontal
≤ 1	bypassed
≤ 14/15	filter 1
≤ 11/15	filter 6
≤ 7/15	filter 3
≤ 3/15	filter 4
YD/YS	vertical
≤ 1	bypassed
≤ 13/15	filter 1
≤ 4/15	filter 2

### RGB matrix

Y data and UV data are converted after interpolation into RGB data according to CCIR601 recommendation. Data are bypassed in 16-bit YUV formats or monochrome modes.

The matrix equations are these considering the digital quantization:

$$R = Y + 1.375 V$$

$$G = Y - 0.703125 V - 0.34375 U$$

$$B = Y + 1.734375 U$$

Anti-gamma ROM tables:

ROM tables are implemented at the matrix output to

## Digital video decoder, scaler and clock generator circuit (DESCPro)

SAA7196

provide anti-gamma correction of the RGB data. A curve for a gamma of 1.4 is implemented. The tables can be used (RTB-bit = 0, subaddress 20) to compensate gamma correction for linear data representation of RGB output data.

### Chrominance signal keyer

The keyer generates an alpha signal to achieve a 5-5-5+ $\alpha$  RGB alpha output signal. Therefore, the processed UV data amplitudes are compared with thresholds set via I<sup>2</sup>C-bus (subaddresses "2C to 2F"). A logical "1" signal is generated if the amplitude is inside the specified amplitude range, otherwise a logical "0" is generated. Keying can be switched off by setting the lower limit higher than the upper limit ("2C or 2E" and "2D or 2F").

### Scale control and vertical regions

The scale control block SC includes address/sequence counters to define the current position in the input field and to address the internal VPU memories.

To perform scaling, XD of XS pixel selection in horizontal direction and YD of YS line selection in vertical direction are applied. The pixel and line dropping are controlled at the input of the FIFO register. The scaling ratio in horizontal and vertical direction is estimated to control the decimation filter function and the vertical data processing in the adaptive mode (AFS and AFG bits).

The input field can be divided into two vertical regions - the bypass region and the scaling region, which are defined via I<sup>2</sup>C-bus by the parameters VS, VC, YO and YS.

#### Vertical bypass region:

Data are not scaled, and independent of IIC-bits FS1 and FS0, the output format is always 8-bit grayscale (monochrome). The SAA7196 outputs all active pixels of a line, defined by the HREF input signal if the vertical bypass region is active.

This can be used, for example, to store videotext information in the field memory.

The start line of the bypass region is defined by the I<sup>2</sup>C-bits VS; the number of lines to be bypassed is defined by VC.

#### Vertical scaling region:

Data is scaled with start at line YO and the output format is selected when FS1 and FS0 are valid. This is the "normal operation" area. The input/output screen dimensions in horizontal and vertical direction are defined by the parameters

XO, XS and XD for horizontal

YO, YS and YD for vertical.

The circuit processes XS samples of a line. Remaining pixels are ignored if a line is longer than XS. If a line is shorter than XS, processing is aborted when the falling edge of HREF is detected. In this case the output line will have less than XD samples.

Vertical regions in Fig.10:

- the two regions can be programmed via I<sup>2</sup>C-bus, whereby regions should not overlap (active region overrides the bypass region).
- the start of a normal active picture depends on video standard and has to be programmed to the correct value.
- the offsets XO and YO have to be set according to the internal processing delays to ensure the complete number of destination pixels and lines (refer to Table 12 on page 42).
- the scaling parameters can be used to perform a panning function over the video frame/field.

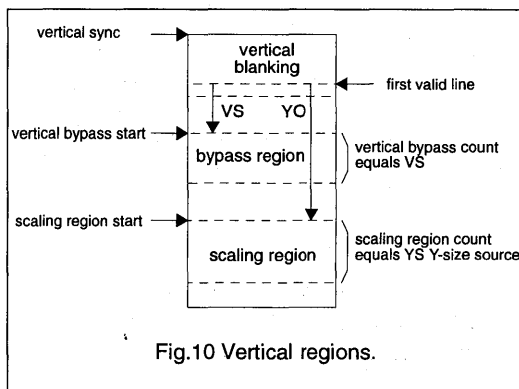

Fig.10 Vertical regions.

# Digital video decoder, scaler and clock generator circuit (DESCPro)

SAA7196

## Output data representation and levels

Output data representation of the YUV data can be modified by bit MCT (subaddress 30). The DC gain is 1 for YUV input data. The corresponding RGB levels are defined by the matrix equations; they are limited to the range of 1 to 254 in the 8-bit domain according to CCIR 601. The luminance levels can be limited to:

16 (239) = black

235 (20) = white

(..) = grayscale luminance levels

(if the YUV or monochrome luminance output formats are selected and LLV-bit = 1).

For the 5-bit RGB formats a truncation from 8-bit to 5-bit word width is implemented. Fill values are inserted dependent on longword position and destination size (see data burst transfer mode):

- "1" for 24-bit RGB, Y and two's complement UV
- "128" for UV (straight binary)
- "254" in 8-bit grayscale format.

## Output FIFO register and VRAM port

The output FIFO register is the buffer between the video data stream and the VRAM data input port. Resized video data are buffered and formatted. 32-, 24 and 16-bit video data modes are supported. The various formats are selected by the bits EFE, VOF, FS1 and FS0. VRAM port formats are shown in Tables 4, 5 and 6. The FIFO register capacity is 16 word x 32 bit (for 32-, 24- or 16-bit video data). The I<sup>2</sup>C-bits LW1, LW0 can be used to define the position of the first pixel each line in the 32-bit-longword formats or to shift the UV sequence to VU in the 16-bit YUV formats. In case of YUV output, an odd pixel count XD results in an incomplete pair of UV data at the end (LW = 0) or beginning (LW = 2) of a line.

VRAM port inputs:

- VMUX, the VRAM output multiplexing signal
- VCLK to clock the FIFO register output data
- VOEN to enable output data.

VRAM port outputs:

- HFL flag (half-full flag)
- INCADR (refer to section "data burst transfer")
- VRO(31-0) VRAM port output data
- the reference signals for pixel and line selection on outputs VRO(7-0) (only for 24- and 16-bit video data formats refer to "transparent data transfer").

## VRAM port transfer procedures

Data transfer on the VRAM port can be done asynchronously controlled by outputs HFL, INCADR and input VCLK (data burst transfer with bit TTR = 0).

Data transfer on the VRAM port can be done synchronously controlled by output reference signals on outputs VRO(7-0) and a continuous VCLK of clock rate of LLC/2 (transparent data transfer with bit TTR = 1).

So the scaling capability of the SAA7196 can be used in various applications.

## Data burst transfer mode

Data transfer on the VRAM port is asynchronously (TTR = 0). This mode can be used for all output formats. Four signals for communication with the external memory are provided.

- HFL flag, the half-full flag of the FIFO output register is raised when the FIFO contains at least 8 data words (HFL = HIGH).

By setting HFL = 1, the SAA7196 requests a data burst transfer by the external memory controller, that has to start a transfer cycle within the next 32 LLC cycles for 32-bit longword modes (16 LLC cycles for 16- and 24-bit modes). If there are pixels in the FIFO at the end of the line, which are not transferred, the circuit fills up the FIFO register with "fill pixels" until it is half-full and sets the HFL flag to request a data burst transfer.

After transfer is done, HFL is used in combination with INCADR to indicate the line increments (Fig.11 on page 27).

- INCADR output signal is used in combination with HFL to control horizontal and vertical address gen-



# Digital video decoder, scaler and clock generator circuit (DESCPro)

SAA7196

eration for a memory controller. The pulse sequence depends on field formats (interlace/non-interlace or odd/even fields, Figures 12 and 13 on page 27 and page 28) and control bits OF1 and OF0 (subaddress 20).

It means:

HFL = 1 at the rising edge of INCADR:  
the END OF LINE is reached; request for line address increment

HFL = 0 at the rising edge of INCADR:  
the END OF FIELD/FRAME is reached; request for line and pixel address reset

- VCLK input signal to clock the FIFO register output data VRO(n). New data are placed on the VRO(n) port with the rising edge of VCLK (Fig.11 on page 27).
- VOEN input enables output data VRO(n). The outputs are in 3-state mode at VOEN = HIGH. VOEN changes only when VCLK is LOW. If VCLK pulses are applied during VOEN = HIGH, the outputs remain inactive, but the FIFO register accepts the pulses.

## Transparent data transfer mode

Data transfer on the VRAM port can be achieved synchronously (TTR = 1) controlled by output reference signals on outputs VRO(7-0), and a continuous clock rate of LLC/2 on input VCLK. The SAA7196 delivers a continuously processed data stream. Therefore, the extended formats of the VRAM output port are selected (bit EFE = 1; Table 6 on page 25). The output signals VRO(7-0) have to be used to buffer qualified pre-processed RGB or YUV video data. To avoid read/write collision at the internal FIFO, the VCLK timing and polarity must accord to the CREFB specification. The YUV data are only valid in qualified time slots. Control output signals are (refer to Table 6 on page 25 and Fig.14 on page 28):

- $\alpha$  keying signal of the chroma keyer
- O/E odd/even field bit according to the internal field processing
- VGT vertical gate signal, "1" marks the scaling window in vertical direction from YO to (YO + YS) lines, cut by VS.

- HGT horizontal gate signal, "1" marks horizontal direction from XO to (XO + XS) lines, cut by HREF.
- HRF delay compensated horizontal reference signal.
- LNQ line qualifier signal, active polarity is defined by QPL bit.
- PXQ pixel qualifier signal, active polarity is defined by QPP bit.

**Note:** Interlaced processing (OF bits, subaddress 20):

To support correct interlaced data storage, the scaler delivers two INCADR/HFL sequences in each qualified line and an additional INCADR/HFL sequence after the vertical reset sequence at the beginning of an ODD field. Thereby, the scaled lines are automatically stored in the right sequence.

INCADR timing:

The distance from the last half-full request (HFL) to the INCADR pulse may be longer than 64 x LLC. The state of HFL is defined for minimum 2 x LLC afterwards.

Monochrome format: (refer to Table 6 on page 25)  
In case of TTR = 1 and EFE = 1 is  $Y_a = Y_b$ .

Table 4 VMUX control

BIT VOF	PIN 53		VRAM BUS	
	VOEN	VMUX	VRO(31-16)	VRO(15-0)
0	0	0	3-state	active
0	0	1	active	3-state
1	0	X	active	active
X	1	X	3-state	3-state

# Digital video decoder, scaler and clock generator circuit (DESCPro)

SAA7196

**Table 5** VRAM port output data formats at EFE-bit = 0 and VOF-bit = 1 (settable via I<sup>2</sup>C-bus), burst mode only

PIXEL OUTPUT BITS	FS1 = 0; FS0 = 0 RGB 5-5-5 + $\alpha$ 32-BIT WORDS			FS1 = 0; FS0 = 1 YUV 4:2:2 32-BIT WORDS			FS1 = 1; FS0 = 0 YUV 4:2:2 16-BIT WORDS			FS1 = 1; FS0 = 1 8-bit monochrome 32-BIT WORDS			
PIXEL ORDER	n	n+2	n+4	n	n+2	n+4	n	n+1	n+2	n	n+4	n+8	
	n+1	n+3	n+5	n+1	n+3	n+5	OUTPUTS NOT USED			n+2	n+6	n+10	
VRO31	$\alpha$	$\alpha$	$\alpha$	Ye7	Ye7	Ye7	Ye7	Yo7	Ye7	Ye7	Ya7	Ya7	Ya7
VRO30	R4	R4	R4	Ye6	Ye6	Ye6	Ye6	Yo6	Ye6	Ye6	Ya6	Ya6	Ya6
VRO29	R3	R3	R3	Ye5	Ye5	Ye5	Ye5	Yo5	Ye5	Ye5	Ya5	Ya5	Ya5
VRO28	R2	R2	R2	Ye4	Ye4	Ye4	Ye4	Yo4	Ye4	Ye4	Ya4	Ya4	Ya4
VRO27	R1	R1	R1	Ye3	Ye3	Ye3	Ye3	Yo3	Ye3	Ye3	Ya3	Ya3	Ya3
VRO26	R0	R0	R0	Ye2	Ye2	Ye2	Ye2	Yo2	Ye2	Ye2	Ya2	Ya2	Ya2
VRO25	G4	G4	G4	Ye1	Ye1	Ye1	Ye1	Yo1	Ye1	Ye1	Ya1	Ya1	Ya1
VRO24	G3	G3	G3	Ye0	Ye0	Ye0	Ye0	Yo0	Ye0	Ye0	Ya0	Ya0	Ya0
VRO23	G2	G2	G2	Ue7	Ue7	Ue7	Ue7	Ve7	Ue7	Ue7	Yb7	Yb7	Yb7
VRO22	G1	G1	G1	Ue6	Ue6	Ue6	Ue6	Ve6	Ue6	Ue6	Yb6	Yb6	Yb6
VRO21	G0	G0	G0	Ue5	Ue5	Ue5	Ue5	Ve5	Ue5	Ue5	Yb5	Yb5	Yb5
VRO20	B4	B4	B4	Ue4	Ue4	Ue4	Ue4	Ve4	Ue4	Ue4	Yb4	Yb4	Yb4
VRO19	B3	B3	B3	Ue3	Ue3	Ue3	Ue3	Ve3	Ue3	Ue3	Yb3	Yb3	Yb3
VRO18	B2	B2	B2	Ue2	Ue2	Ue2	Ue2	Ve2	Ue2	Ue2	Yb2	Yb2	Yb2
VRO17	B1	B1	B1	Ue1	Ue1	Ue1	Ue1	Ve1	Ue1	Ue1	Yb1	Yb1	Yb1
VRO16	B0	B0	B0	Ue0	Ue0	Ue0	Ue0	Ve0	Ue0	Ue0	Yb0	Yb0	Yb0
VRO15	$\alpha$	$\alpha$	$\alpha$	Yo7	Yo7	Yo7	X	X	X	X	Yc7	Yc7	Yc7
VRO14	R4	R4	R4	Yo6	Yo6	Yo6	X	X	X	X	Yc6	Yc6	Yc6
VRO13	R3	R3	R3	Yo5	Yo5	Yo5	X	X	X	X	Yc5	Yc5	Yc5
VRO12	R2	R2	R2	Yo4	Yo4	Yo4	X	X	X	X	Yc4	Yc4	Yc4
VRO11	R1	R1	R1	Yo3	Yo3	Yo3	X	X	X	X	Yc3	Yc3	Yc3
VRO10	R0	R0	R0	Yo2	Yo2	Yo2	X	X	X	X	Yc2	Yc2	Yc2
VRO9	G4	G4	G4	Yo1	Yo1	Yo1	X	X	X	X	Yc1	Yc1	Yc1
VRO8	G3	G3	G3	Yo0	Yo0	Yo0	X	X	X	X	Yc0	Yc0	Yc0
VRO7	G2	G2	G2	Ve7	Ve7	Ve7	X	X	X	X	Yd7	Yd7	Yd7
VRO6	G1	G1	G1	Ve6	Ve6	Ve6	X	X	X	X	Yd6	Yd6	Yd6
VRO5	G0	G0	G0	Ve5	Ve5	Ve5	X	X	X	X	Yd5	Yd5	Yd5
VRO4	B4	B4	B4	Ve4	Ve4	Ve4	X	X	X	X	Yd4	Yd4	Yd4
VRO3	B3	B3	B3	Ve3	Ve3	Ve3	X	X	X	X	Yd3	Yd3	Yd3
VRO2	B2	B2	B2	Ve2	Ve2	Ve2	X	X	X	X	Yd2	Yd2	Yd2
VRO1	B1	B1	B1	Ve1	Ve1	Ve1	X	X	X	X	Yd1	Yd1	Yd1
VRO0	B0	B0	B0	Ve0	Ve0	Ve0	X	X	X	X	Yd0	Yd0	Yd0

$\alpha$  = keying bit; R, G, B Y, U and V = digital signals; e = even pixel number; o = odd pixel number;  
a b c d = consecutive pixels

# Digital video decoder, scaler and clock generator circuit (DESCPro)

SAA7196

**Table 6** VRAM port output data formats at  $\text{EFE-bit} = 1$  and  $\text{VOFbit} = 1$  (settable via I<sup>2</sup>C-bus), burst- and transparent- modes

PIXEL OUTPUT BITS	FS1 = 0; FS0 = 0 RGB 5-5-5 + $\alpha$ 16-BIT WORDS			FS1 = 0; FS0 = 1 YUV 4:2:2 16-BIT WORDS			FS1 = 1; FS0 = 0 RGB 8-8-8 24-BIT WORDS			FS1 = 1; FS0 = 1 8-bit monochrome 16-BIT WORDS		
PIXEL ORDER	n	n+1	n+2	n	n+1	n+2	n	n+1	n+2	n	n+2	n+4
VRO31	$\alpha$	$\alpha$	$\alpha$	Ye7	Yo7	Ye7	R7	R7	R7	Ya7	Ya7	Ya7
VRO30	R4	R4	R4	Ye6	Yo6	Ye6	R6	R6	R6	Ya6	Ya6	Ya6
VRO29	R3	R3	R3	Ye5	Yo5	Ye5	R5	R5	R5	Ya5	Ya5	Ya5
VRO28	R2	R2	R2	Ye4	Yo4	Ye4	R4	R4	R4	Ya4	Ya4	Ya4
VRO27	R1	R1	R1	Ye3	Yo3	Ye3	R3	R3	R3	Ya3	Ya3	Ya3
VRO26	R0	R0	R0	Ye2	Yo2	Ye2	R2	R2	R2	Ya2	Ya2	Ya2
VRO25	G4	G4	G4	Ye1	Yo1	Ye1	R1	R1	R1	Ya1	Ya1	Ya1
VRO24	G3	G3	G3	Ye0	Yo0	Ye0	R0	R0	R0	Ya0	Ya0	Ya0
VRO23	G2	G2	G2	Ue7	Ve7	Ue7	G7	G7	G7	Yb7	Yb7	Yb7
VRO22	G1	G1	G1	Ue6	Ve6	Ue6	G6	G6	G6	Yb6	Yb6	Yb6
VRO21	G0	G0	G0	Ue5	Ve5	Ue5	G5	G5	G5	Yb5	Yb5	Yb5
VRO20	B4	B4	B4	Ue4	Ve4	Ue4	G4	G4	G4	Yb4	Yb4	Yb4
VRO19	B3	B3	B3	Ue3	Ve3	Ue3	G3	G3	G3	Yb3	Yb3	Yb3
VRO18	B2	B2	B2	Ue2	Ve2	Ue2	G2	G2	G2	Yb2	Yb2	Yb2
VRO17	B1	B1	B1	Ue1	Ve1	Ue1	G1	G1	G1	Yb1	Yb1	Yb1
VRO16	B0	B0	B0	Ue0	Ve0	Ue0	G0	G0	G0	Yb0	Yb0	Yb0
PIXEL ORDER	n	n+1	n+2	n	n+1	n+2	n	n+1	n+2	n	n+2	n+4
VRO15	X	X	X	X	X	X	B7	B7	B7	X	X	X
VRO14	X	X	X	X	X	X	B6	B6	B6	X	X	X
VRO13	X	X	X	X	X	X	B5	B5	B5	X	X	X
VRO12	X	X	X	X	X	X	B4	B4	B4	X	X	X
VRO11	X	X	X	X	X	X	B3	B3	B3	X	X	X
VRO10	X	X	X	X	X	X	B2	B2	B2	X	X	X
VRO9	X	X	X	X	X	X	B1	B1	B1	X	X	X
VRO8	X	X	X	X	X	X	B0	B0	B0	X	X	X
VRO7 <sup>(1)(2)</sup>	$\alpha$	$\alpha$	$\alpha$	$\alpha$	X	$\alpha$	$\alpha$	$\alpha$	$\alpha$	$\alpha$	$\alpha$	$\alpha$
VRO6 <sup>(2)</sup>	O/E	O/E	O/E	O/E	O/E	O/E	O/E	O/E	O/E	O/E	O/E	O/E
VRO5 <sup>(2)</sup>	VGt	VGt	VGt	VGt	VGt	VGt	VGt	VGt	VGt	VGt	VGt	VGt
VRO4 <sup>(2)</sup>	HGt	HGt	HGt	HGt	HGt	HGt	HGt	HGt	HGt	HGt	HGt	HGt
VRO3	X	X	X	X	X	X	X	X	X	X	X	X
VRO2 <sup>(2)</sup>	HRF	HRF	HRF	HRF	HRF	HRF	HRF	HRF	HRF	HRF	HRF	HRF
VRO1 <sup>(2)</sup>	LNQ	LNQ	LNQ	LNQ	LNQ	LNQ	LNQ	LNQ	LNQ	LNQ	LNQ	LNQ
VRO0 <sup>(2)</sup>	PXQ	PXQ	PXQ	PXQ	PXQ	PXQ	PXQ	PXQ	PXQ	PXQ	PXQ	PXQ

$\alpha$  = keying bit; R, G, B, Y, U and V = digital signals; e = even pixel number; o = odd pixel number; a b = consecutive pixels; O/E = odd/even flag

(1) YUV 16-bit format: the keying signal  $\alpha$  is defined only for YU time steps. The corresponding YV sample has also to be keyed. The  $\alpha$  signal in monochrome mode can be used only in the transparent mode (TTR = 1), in this case  $Y_a = Y_b$ .

(2) Data valid only when transparent mode active (TTR-bit = 1) and VCLK pin connected to LLC/2 clock rate.

# Digital video decoder, scaler and clock generator circuit (DESCPro)

SAA7196

**Table 7** VRAM port output data formats at  $EFE\text{-bit} = 0$  and  $VOF\text{-bit} = 0$  (settable via I<sup>2</sup>C-bus), burst mode only

PIXEL OUTPUT BITS	FS1 = 0; FS0 = 0 RGB 5-5-5 + $\alpha$ 32-BIT LONGWORD				FS1 = 0; FS0 = 1 YUV 4:2:2 32-BIT LONGWORD				FS1 = 1; FS0 = 1 8-bit monochrome 32-BIT LONGWORD			
	n		n+2		n		n+2		n n+1		n+4 n+5	
VMUX	1	0	1	0	1	0	1	0	1	0	1	0
VRO31	$\alpha$	Z	$\alpha$	Z	Ye7	Z	Ye7	Z	Ya7	Z	Ya7	Z
VRO30	R4	Z	R4	Z	Ye6	Z	Ye6	Z	Ya6	Z	Ya6	Z
VRO29	R3	Z	R3	Z	Ye5	Z	Ye5	Z	Ya5	Z	Ya5	Z
VRO28	R2	Z	R2	Z	Ye4	Z	Ye4	Z	Ya4	Z	Ya4	Z
VRO27	R1	Z	R1	Z	Ye3	Z	Ye3	Z	Ya3	Z	Ya3	Z
VRO26	R0	Z	R0	Z	Ye2	Z	Ye2	Z	Ya2	Z	Ya2	Z
VRO25	G4	Z	G4	Z	Ye1	Z	Ye1	Z	Ya1	Z	Ya1	Z
VRO24	G3	Z	G3	Z	Ye0	Z	Ye0	Z	Ya0	Z	Ya0	Z
VRO23	G2	Z	G2	Z	Ue7	Z	Ue7	Z	Yb7	Z	Yb7	Z
VRO22	G1	Z	G1	Z	Ue6	Z	Ue6	Z	Yb6	Z	Yb6	Z
VRO21	G0	Z	G0	Z	Ue5	Z	Ue5	Z	Yb5	Z	Yb5	Z
VRO20	B4	Z	B4	Z	Ue4	Z	Ue4	Z	Yb4	Z	Yb4	Z
VRO19	B3	Z	B3	Z	Ue3	Z	Ue3	Z	Yb3	Z	Yb3	Z
VRO18	B2	Z	B2	Z	Ue2	Z	Ue2	Z	Yb2	Z	Yb2	Z
VRO17	B1	Z	B1	Z	Ue1	Z	Ue1	Z	Yb1	Z	Yb1	Z
VRO16	B0	Z	B0	Z	Ue0	Z	Ue0	Z	Yb0	Z	Yb0	Z
PIXEL ORDER	n+1		n+3		n+1		n+3		n+2 n+3		n+6 n+7	
VMUX	1	0	1	0	1	0	1	0	1	0	1	0
VRO15	Z	$\alpha$	Z	$\alpha$	Z	Yo7	Z	Yo7	Z	Yc7	Z	Yc7
VRO14	Z	R4	Z	R4	Z	Yo6	Z	Yo6	Z	Yc6	Z	Yc6
VRO13	Z	R3	Z	R3	Z	Yo5	Z	Yo5	Z	Yc5	Z	Yc5
VRO12	Z	R2	Z	R2	Z	Yo4	Z	Yo4	Z	Yc4	Z	Yc4
VRO11	Z	R1	Z	R1	Z	Yo3	Z	Yo3	Z	Yc3	Z	Yc3
VRO10	Z	R0	Z	R0	Z	Yo2	Z	Yo2	Z	Yc2	Z	Yc2
VRO9	Z	G4	Z	G4	Z	Yo1	Z	Yo1	Z	Yc1	Z	Yc1
VRO8	Z	G3	Z	G3	Z	Yo0	Z	Yo0	Z	Yc0	Z	Yc0
VRO7	Z	G2	Z	G2	Z	Ve7	Z	Ve7	Z	Yd7	Z	Yd7
VRO6	Z	G1	Z	G1	Z	Ve6	Z	Ve6	Z	Yd6	Z	Yd6
VRO5	Z	G0	Z	G0	Z	Ve5	Z	Ve5	Z	Yd5	Z	Yd5
VRO4	Z	B4	Z	B4	Z	Ve4	Z	Ve4	Z	Yd4	Z	Yd4
VRO3	Z	B3	Z	B3	Z	Ve3	Z	Ve3	Z	Yd3	Z	Yd3
VRO2	Z	B2	Z	B2	Z	Ve2	Z	Ve2	Z	Yd2	Z	Yd2
VRO1	Z	B1	Z	B1	Z	Ve1	Z	Ve1	Z	Yd1	Z	Yd1
VRO0	Z	B0	Z	B0	Z	Ve0	Z	Ve0	Z	Yd0	Z	Yd0

$\alpha$  = keying bit; R, G, B, Y, U and V = digital signals; e = even pixel number; o = odd pixel number; a b c d = consecutive pixels;  
Z = high-ohmic (3-state).

Digital video decoder, scaler  
and clock generator circuit (DESCPro)

SAA7196

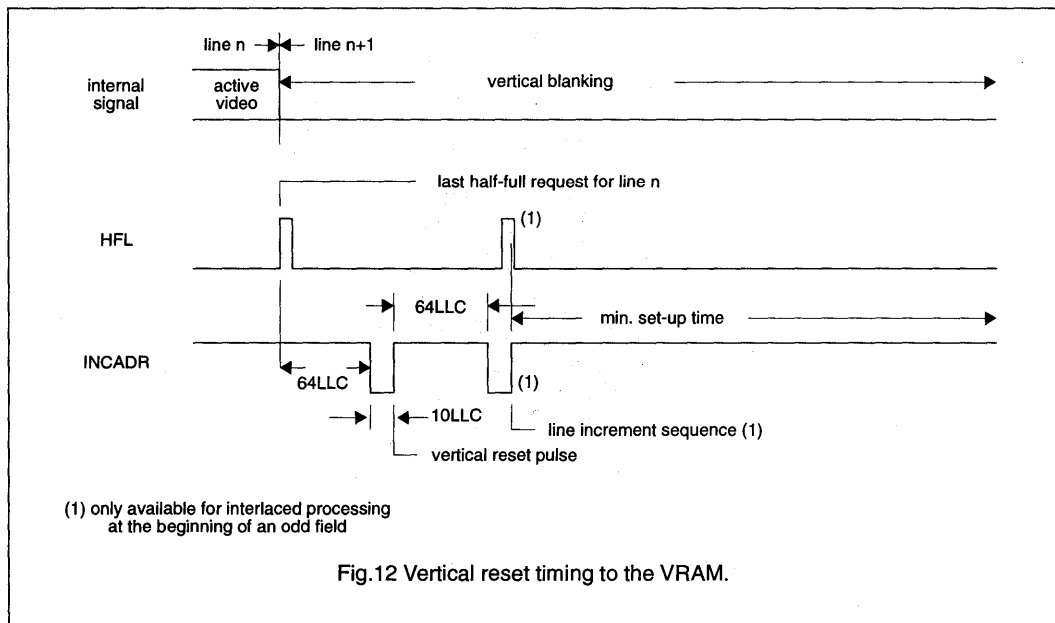
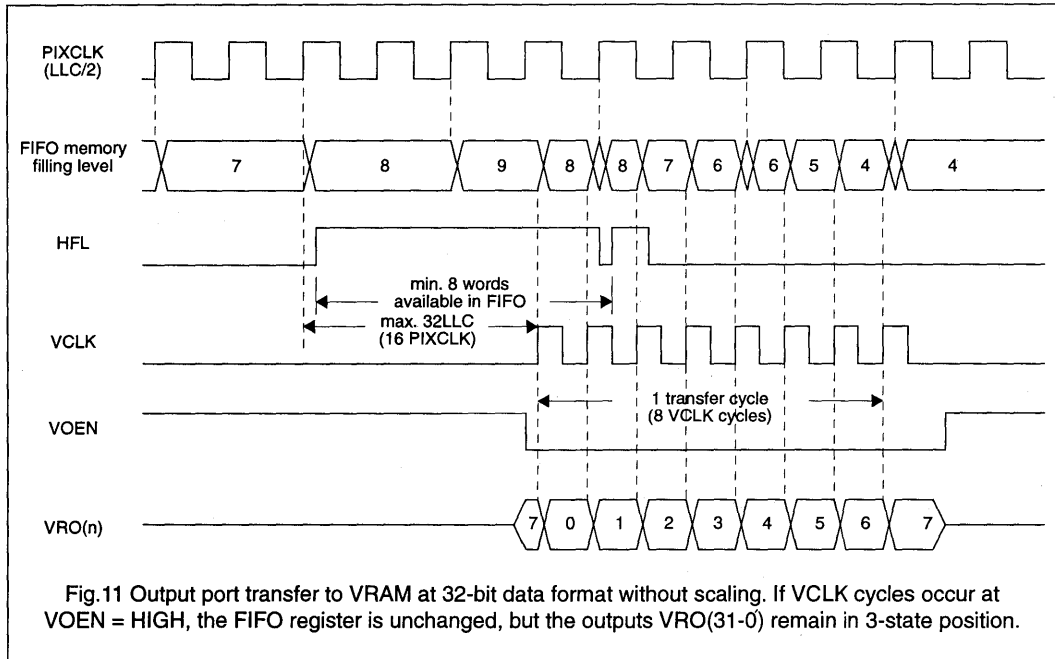

Digital video decoder, scaler  
and clock generator circuit (DESCPro)

SAA7196

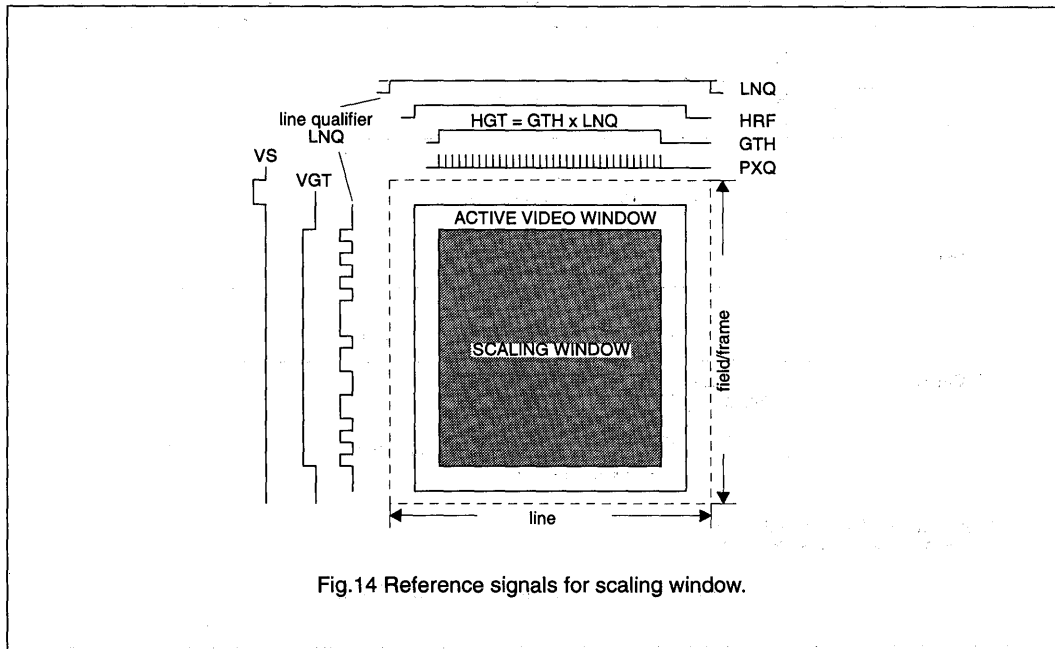
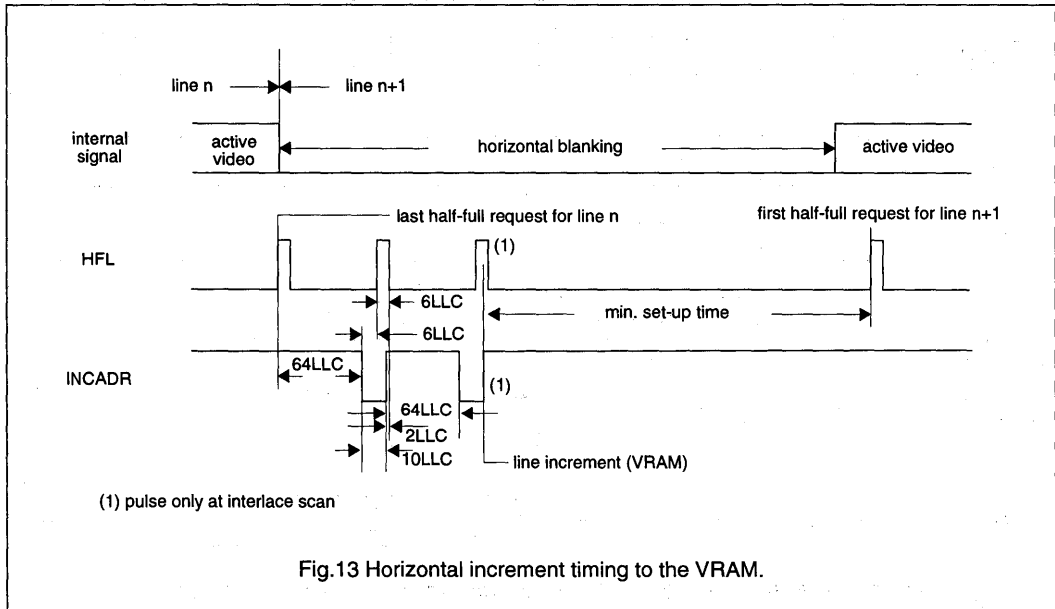

Digital video decoder, scaler  
and clock generator circuit (DESCPro)

SAA7196

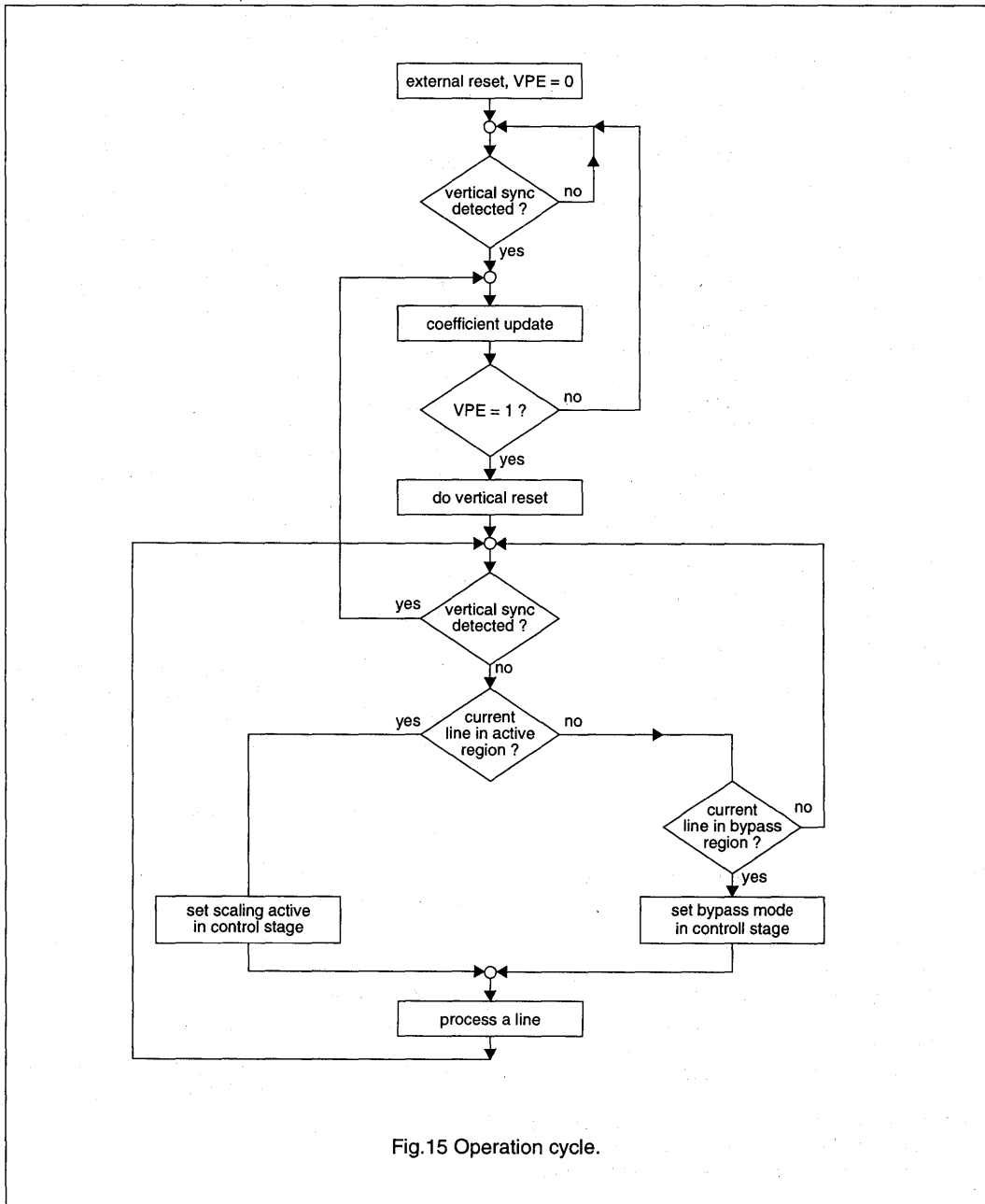

Fig.15 Operation cycle.

# Digital video decoder, scaler and clock generator circuit (DESCPro)

SAA7196

## Field processing

The phase of the field sequence (odd/even dependent on inputs HREF and VS) is detected by means of the falling edge of VS. The current field phase is reported in the status byte by the OEF bit (Table 8 on page 31). OEF bit can be stable 0 or 1 for non-interlaced input frames or non-standard input signals VS and/or HREF (nominal condition for VS and HREF - SAA7196 with active vertical noise limiter). A free-running odd/even flag is generated for internal field processing if the detection reports a stable OEF bit. The POE bit (subaddress 0B) can be used to change the polarity of the internal flag (in case of non-standard VS and HREF signals) to control the phase of the free-running flag and to compensate mis-detections. Thus, the SAA7196 can be used under various VS/HREF timing conditions.

The SAA7196 operates on fields. To support progressive displays and to avoid movement blurring and artifacts, the circuit can process both or single fields of interlaced or non-interlaced input data. Therefore the OF bits can be used. The bits OF1 and OF0 (Table 12 on page 42) determine the INCADR/HFL generation in "data burst transfer mode". One of the fields (odd or even) is ignored when OF1 = 1; then no line increment sequence (INCADR/HFL) is generated, the vertical reset pulse is only generated.

With OF1 = OF0 = 0 the circuit supports correct interlaced data storage (see note of previously described "transparent data transfer").

## Operation cycle

The operation is synchronized by the input field. The cycle is specified in the flow chart (Fig.15 on page 29).

The circuit is inactive after power-on reset, VPE is 0 and the FIFO control is set "empty". The internal control registers are updated with the falling edge of VS signal. The circuit is switched active and waits for a transmission of VS and a vertical reset sequence to the memory controller. Afterwards, the scaler waits for the beginning of a scaling or bypass region. If the active scaling region begins, while the bypass region is active, the bypass region is interrupted. If a vertical sync appears, the processing of the current

line is finished. Then, the scaler performs a coefficient update and generates a new vertical reset (if it is still active).

Line processing starts when a line is decided to be active, the circuit starts to scale it. Active pixels are loaded into the FIFO register. An HFL flag is generated to initialize a data transfer when eight words are completed. The end of a line is reached when the programmed pixel number is processed or when a horizontal sync pulse occurs. If there are pixels in the FIFO register, it is filled up until it is half-full to cause a data transfer. Horizontal increment pulses are transmitted after this data transfer.

## Remarks:

The scaler part will always wait for the HREF/VS pulse before the line increment/vertical reset sequence is performed.

After each line/field, the FIFO control is set to empty when the increment/vertical reset pulses are transmitted. No additional actions are necessary if the memory controller has ignored the HFL signal. There is no need to handle over-/underflow of the FIFO register.

## 7.5. POWER-ON RESET

Power-on reset is activated at power-on or when the supply voltage decreases below 3.5 V. The indicator output RESN is low for a time. The RESN signal can be applied to reset other circuits of the digital TV system.

- the bits VTRC and SSTB in subaddress "0Dh" are set to zero
- all bits in subaddress "0Eh" are set to zero
- the FIFO register contents are undefined
- outputs VRO, YUV, CREFB, LLCB, HREF, HS and VS are set to 3-state
- output INCADR = HIGH
- output HFL = LOW until the VPE bit is set to "1"
- subaddress "30" is set to 00h and VPE-bit in subaddress "20h" is set to zero (Table 11 on page 42).



# Digital video decoder, scaler and clock generator circuit (DESCPro)

SAA7196

## 8. I<sup>2</sup>C-BUS FORMAT

S	SLAVE ADDRESS	A	SUBADDRESS	A	DATA0	A	-----	DATAn	A	P
---	---------------	---	------------	---	-------	---	-------	-------	---	---

- S = start condition
- SLAVE ADDRESS = 0100 000X (IICSA = LOW) or 0100 001X (IICSA = HIGH)
- A = acknowledge, generated by the slave
- SUBADDRESS\* = subaddress byte (Tables 9 to 12)
- DATA = data byte (Tables 9 to 12)
- P = stop condition
  
- X = read/write control bit  
 X = 0, order to write (the circuit is slave receiver)  
 X = 1, order to read (the circuit is slave transmitter)

\* If more than 1 byte DATA are transmitted, then auto-increment of the subaddress is performed.

**Table 8** I<sup>2</sup>C-bus status byte (X in address byte = 1; 41h at IICSA = LOW or 43h at IICSA = HIGH).

FUNCTION	DATA							
	D7	D6	D5	D4	D3	D2	D1	D0
status byte 0 (transmitted after RESN = 0 or at SSTB = 0)	ID3	ID2	ID1	ID0	DIR	X	OEF	SVP
status byte 1 (transmitted at SSTB = 1)	STTC	HLCK	FIDT	X	X	X	ALTD	CODE

Function of status bits:  
ID3 to ID0

Software model of SAA7196 compatible with

ID3	ID2	ID1	ID0	VERSION
0	0	0	0	V0 (first version)

- DIR State of input DIR (pin 95): direction control of Expansion port YUV  
 DIR = 0: the scaler uses internal source (decoder output)  
 DIR = 1: the scaler uses external data of expansion bus
- OEF Identification of field sequence dependent on HREF and VS:  
 0 = even field detected; 1 = odd field detected
- SVP State of VRAM port (state of, VPE-bit cleared by RESN):  
 0 = inputs HFL and INCADR inactive  
 1 = inputs HFL and INCADR active
- STTC Horizontal time constant information (for future application with logical comb-filter only):  
 0 = TV time constant (slow)  
 1 = VCR time constant (fast)
- HLCK Horizontal PLL information: 0 = HPLL locked; 1 = HPLL unlocked
- FIDT Field information: 0 = 50 Hz system detected; 1 = 60 Hz system detected
- ALTD Line alternation: 0 = no line alternating colour burst detected  
 1 = line alternating colour burst detected (PAL or SECAM)
- CODE Colour information: 0 = no colour detected; 1 = colour detected
- X for future enhancements, do not evaluate

# Digital video decoder, scaler and clock generator circuit (DESCPro)

SAA7196

**Table 9** I<sup>2</sup>C-bus decoder control; subaddress and data bytes for writing (X in address byte = 0;  
40h at IICSA = LOW or 42h at IICSA = HIGH)

FUNCTION SUBADDRESS		DATA								DF*
		D7	D6	D5	D4	D3	D2	D1	D0	
Increment delay	00	IDEL7	IDEL6	IDEL5	IDEL4	IDEL3	IDEL2	IDEL1	IDEL0	
H-sync begin; 50 Hz	01	HSYB7	HSYB6	HSYB5	HSYB4	HSYB3	HSYB2	HSYB1	HSYB0	
H-sync stop; 50 Hz	02	HSYS7	HSYS6	HSYS5	HSYS4	HSYS3	HSYS2	HSYS1	HSYS0	
H-clamp begin; 50 Hz	03	HCLB7	HCLB6	HCLB5	HCLB4	HCLB3	HCLB2	HCLB1	HCLB0	
H-clamp stop; 50 Hz	04	HCLS7	HCLS6	HCLS5	HCLS4	HCLS3	HCLS2	HCLS1	HCLS0	
H-sync after PHI1; 50 Hz	05	HPHI7	HPHI6	HPHI5	HPHI4	HPHI3	HPHI2	HPHI1	HPHI0	
Luminance control	06	BYP5	PREF	BPSS1	BPSS0	COR11	COR10	APER1	APER0	
Hue control	07	HUEC7	HUEC6	HUEC5	HUEC4	HUEC3	HUEC2	HUEC1	HUEC0	
Colour-killer QUAM	08	CKTQ4	CKTQ3	CKTQ2	CKTQ1	CKTQ0	0	0	0	
Colour-killer SECAM	09	CKTS4	CKTS3	CKTS2	CKTS1	CKTS0	0	0	0	
PAL switch sensitivity	0A	PLSE7	PLSE6	PLSE5	PLSE4	PLSE3	PLSE2	PLSE1	PLSE0	
SECAM switch sensitivity	0B	SESE7	SESE6	SESE5	SESE4	SESE3	SESE2	SESE1	SESE0	
Chroma gain control	0C	COLO	LFIS1	LFIS0	0	0	0	0	0	
Standard/mode control	0D	VTRC	0	0	0	RTSE	HRMV	SSTB	SECS	
I/O and clock control	0E	HPLL	0	OECL	OEHV	OEYC	CHRS	GPSW2	GPSW1	
Control #1	0F	AUFD	FSEL	SXCR	SCEN	0	YDEL2	YDEL1	YDEL0	
Control #2	10	0	0	0	0	0	HRFS	VNOI1	VNOI0	
Chroma gain reference	11	CHCV7	CHCV6	CHCV5	CHCV4	CHCV3	CHCV2	CHCV1	CHCV0	
Chroma saturation	12	0	SATN6	SATN5	SATN4	SATN3	SATN2	SATN1	SATN0	
Luminance contrast	13	0	CONT6	CONT5	CONT4	CONT3	CONT2	CONT1	CONT0	
H-sync begin; 60 Hz	14	HS6B7	HS6B6	HS6B5	HS6B4	HS6B3	HS6B2	HS6B1	HS6B0	
H-sync stop; 60 Hz	15	HS6B7	HS6B6	HS6B5	HS6B4	HS6B3	HS6B2	HS6B1	HS6B0	
H-clamp begin; 60 Hz	16	HC6B7	HC6B6	HC6B5	HC6B4	HC6B3	HC6B2	HC6B1	HC6B0	
H-clamp stop; 60 Hz	17	HC6S7	HC6S6	HC6S5	HC6S4	HC6S3	HC6S2	HC6S1	HC6S0	
H-sync after PHI1; 60 Hz	18	HP6I7	HP6I6	HP6I5	HP6I4	HP6I3	HP6I2	HP6I1	HP6I0	
Luminance brightness	19	BRIG7	BRIG6	BRIG5	BRIG4	BRIG3	BRIG2	BRIG1	BRIG0	
Reserved	1A to 1F	0	0	0	0	0	0	0	0	

\*) Default register contents fill in by hand

# Digital video decoder, scaler and clock generator circuit (DESCPro)

SAA7196

**Table 10** Function of the register bits of Table 9 for subaddresses "00" to "19"

IDEL7 to IDELO "00"	<p>Increment delay time (dependent on application), step size = 4 / LLC. The delay time is selectable from -4 / LLC (-1 decimal multiplier) to -1024 / LLC (-256 decimal multiplier) equals data FF to 00 (hex). A sign-bit, designated A08 and internally set HIGH, indicates always negative values.</p> <p>The maximum delay time in 60 Hz systems is -780 equally to 3D (hex); the maximum delay time in 50 Hz systems is -944 equally to 14 (hex).</p> <p>Different processing times in the chrominance channel and the clock generation could result in phase errors in the chrominance processing by transients in clock frequency.</p> <p>An adjustable delay (IDEL) is necessary if the processing time in the clock generation is unknown.</p> <p>(The horizontal PLL does not operate if the maximum delays are exceeded. The system clock frequency is set to a value of the last update and is within <math>\pm 7.1</math> % of nominal frequency).</p>															
HSYB7 to HSYB0 "01"	<p>Horizontal sync begin for 50 Hz, step size = 2 / LLC. The delay time is selectable from -382/LLC (+191 decimal multiplier) to +128/LLC (-64 decimal multiplier) equals data BF to C0 (hex). Two's complement numbers with "hidden" sign-bit. The sign-bit is generated internally by evaluating the MSB and the MSB-1 bits.</p>															
HSYS7 to HSYS0 "02"	<p>Horizontal sync stop for 50 Hz, step size = 2 / LLC. The delay time is selectable from -382/LLC (+191 decimal multiplier) to +128/LLC (-64 decimal multiplier) equals data BF to C0 (hex). Two's complement numbers with "hidden" sign-bit. The sign-bit is generated internally by evaluating the MSB and the MSB-1 bits.</p>															
HCLB7 to HCLB0 "03"	<p>Horizontal clamp start for 50 Hz, step size = 2 / LLC. The delay time is selectable from -254/LLC (+127 decimal multiplier) to +256/LLC (-128 decimal multiplier) equals data 7F to 80 (hex).</p>															
HCLS7 to HCLS0 "04"	<p>Horizontal clamp stop for 50 Hz, step size = 2 / LLC. The delay time is selectable from -254/LLC (+127 decimal multiplier) to +256/LLC (-128 decimal multiplier) equals data 7F to 80 (hex).</p>															
HPHI7 to HPHI0 "05"	<p>Horizontal sync start after PHI1 for 50 Hz, step size = 8 / LLC. The delay time is selectable from -32 to +31.7 <math>\mu</math>s (+118 to -118 decimal multiplier) equals data 75 to 8A (hex). Forbidden, outside available central counter range, are +127 to +118 decimal multiplier equals data 7E to 76 (hex) as well as -119 to -128 decimal multiplier equals data 89 to 80 (hex).</p>															
BYPS "06"	<p>input mode select bit:</p> <p>0 = CVBS mode (chrominance trap active)</p> <p>1 = S-Video mode ( chrominance trap bypassed)</p>															
PREF	<p>use of pre-filter:</p> <p>0 = pre-filter off (bypassed)</p> <p>1 = pre-filter on; PREF may be used if chrominance trap is active</p>															
BPSS1 to BPSS0	<p>Aperture bandpass to select different characteristics with maximums (0.2 to 0.3 x LLC / 2):</p> <table border="1"> <thead> <tr> <th>BPSS1</th> <th>BPSS0</th> <th>characteristics</th> </tr> </thead> <tbody> <tr> <td>0</td> <td>0</td> <td>)</td> </tr> <tr> <td>0</td> <td>1</td> <td>)</td> </tr> <tr> <td>1</td> <td>0</td> <td>)</td> </tr> <tr> <td>1</td> <td>1</td> <td>)</td> </tr> </tbody> </table> <p style="text-align: right;">Figures 17 to 26</p>	BPSS1	BPSS0	characteristics	0	0	)	0	1	)	1	0	)	1	1	)
BPSS1	BPSS0	characteristics														
0	0	)														
0	1	)														
1	0	)														
1	1	)														

# Digital video decoder, scaler and clock generator circuit (DESCPro)

SAA7196

CORI1 to CORIO "06"	<p>Coring range for high frequency components according to 8-bit luminance, Fig.16 on page 37:</p> <table border="1"> <thead> <tr> <th>CORI1</th> <th>CORIO</th> <th>coring</th> </tr> </thead> <tbody> <tr> <td>0</td> <td>0</td> <td>coring off</td> </tr> <tr> <td>0</td> <td>1</td> <td>±1 LSB of 8-bit</td> </tr> <tr> <td>1</td> <td>0</td> <td>±2 LSB of 8-bit</td> </tr> <tr> <td>1</td> <td>1</td> <td>±3 LSB of 8-bit</td> </tr> </tbody> </table>	CORI1	CORIO	coring	0	0	coring off	0	1	±1 LSB of 8-bit	1	0	±2 LSB of 8-bit	1	1	±3 LSB of 8-bit					
CORI1	CORIO	coring																			
0	0	coring off																			
0	1	±1 LSB of 8-bit																			
1	0	±2 LSB of 8-bit																			
1	1	±3 LSB of 8-bit																			
APER1 to APER0	<p>Aperture bandpass filter weights high frequency components of luminance signal:</p> <table border="1"> <thead> <tr> <th>APER1</th> <th>APER0</th> <th>factor</th> <th></th> </tr> </thead> <tbody> <tr> <td>0</td> <td>0</td> <td>0</td> <td>)</td> </tr> <tr> <td>0</td> <td>1</td> <td>0.25</td> <td>)</td> </tr> <tr> <td>1</td> <td>0</td> <td>0.5</td> <td>)</td> </tr> <tr> <td>1</td> <td>1</td> <td>1</td> <td>)</td> </tr> </tbody> </table> <p>Figures 17 to 26</p>	APER1	APER0	factor		0	0	0	)	0	1	0.25	)	1	0	0.5	)	1	1	1	)
APER1	APER0	factor																			
0	0	0	)																		
0	1	0.25	)																		
1	0	0.5	)																		
1	1	1	)																		
HUE7 to HUE0 "07"	Hue control from +178.6° to -180.0° equals data bytes 7F to 80 (hex); 0° equals 00																				
CKTQ4 to CKTQ0 "08"	Colour-killer threshold QAM (PAL,NTSC) from approximately -30 dB to -18 dB equals data bytes F8 to 07 (hex)																				
CKTS4 to CKTS0 "09"	Colour-killer threshold SECAM from approximately -30 dB to -18 dB equals data bytes F8 to 07 (hex)																				
PLSE7 to PLSE0 "0A"	PAL switch sensitivity from LOW to HIGH (HIGH means immediate sequence correction) equals FF to 00 (hex), MEDIUM equals 80																				
SESE7 to SESE0 "0B"	SECAM switch sensitivity from LOW to HIGH (HIGH means immediate sequence correction) equals FF to 00 (hex), MEDIUM equals 80																				
COLO "0C"	<p>Colour-on bit:</p> <p>0 = automatic colour-killer 1 = forced colour-on.</p>																				
LFIS1 to LFIS0	<p>Automatic gain control (AGC filter):</p> <table border="1"> <thead> <tr> <th>LFIS1</th> <th>LFIS0</th> <th>loop filter time constant</th> </tr> </thead> <tbody> <tr> <td>0</td> <td>0 =</td> <td>slow</td> </tr> <tr> <td>0</td> <td>1 =</td> <td>medium</td> </tr> <tr> <td>1</td> <td>0 =</td> <td>fast</td> </tr> <tr> <td>1</td> <td>1 =</td> <td>actual gain stored (for test purposes only)</td> </tr> </tbody> </table>	LFIS1	LFIS0	loop filter time constant	0	0 =	slow	0	1 =	medium	1	0 =	fast	1	1 =	actual gain stored (for test purposes only)					
LFIS1	LFIS0	loop filter time constant																			
0	0 =	slow																			
0	1 =	medium																			
1	0 =	fast																			
1	1 =	actual gain stored (for test purposes only)																			
VTRC "0D"	<p>VTR/TV mode bit:</p> <p>0 = TV mode 1 = VTR mode</p>																				
RTSE	<p>Realtime output mode select bit:</p> <p>0 = PLIN switched to output RTS1 (pin 34); ODD switched to RTS0 (pin 35) 1 = HL switched to output RTS1 (pin34); VL switched to RTS0 (pin 35)</p>																				
HRMV	<p>HREF position select:</p> <p>0 = default 1 = HREF is 8 x LLC2 clocks earlier</p>																				
SSTB	<p>Status byte select:</p> <p>0 = status byte 0 selected 1 = status byte 1 selected</p>																				

# Digital video decoder, scaler and clock generator circuit (DESCPro)

SAA7196

SECS "0D"	SECAM mode bit: 0 = other standards 1 = SECAM																																													
HPLL "0E"	Horizontal clock PLL: 0 = PLL closed 1 = PLL open and horizontal frequency fixed																																													
OECL	Select internal/external clock source: 0 = LLCB and CREFB are inputs 1 = LLCB and CREFB are outputs																																													
OEHV	Output enable of horizontal/vertical sync: 0 = HS, HREF and VS pins are inputs (outputs high-impedance) 1 = HS, HREF and VS pins are outputs																																													
OEYC	Data output YUV(15-0) enable: 0 = data pins are inputs 1 = data pins are controlled by DIR (pin 95)																																													
CHRS	S-VHS bit (chrominance from CVBS or from chrominance input): 0 = controlled by BYPS-bit (subaddress 06) 1 = chrominance from chrominance input (CHR(7-0))																																													
GPSW2 to GPSW1	General purpose switches:  <table style="margin-left: auto; margin-right: auto;"> <tr> <td style="text-align: center;">GPSW2</td> <td style="text-align: center;">GPSW1</td> <td style="text-align: center;">set port output pins 32 (GPSW2) and 33 (GPSW1)</td> </tr> <tr> <td style="text-align: center;">0</td> <td style="text-align: center;">0</td> <td></td> </tr> <tr> <td style="text-align: center;">0</td> <td style="text-align: center;">1</td> <td style="text-align: right;">use is dependent</td> </tr> <tr> <td style="text-align: center;">1</td> <td style="text-align: center;">0</td> <td style="text-align: right;">on application</td> </tr> <tr> <td style="text-align: center;">1</td> <td style="text-align: center;">1</td> <td></td> </tr> </table>	GPSW2	GPSW1	set port output pins 32 (GPSW2) and 33 (GPSW1)	0	0		0	1	use is dependent	1	0	on application	1	1																															
GPSW2	GPSW1	set port output pins 32 (GPSW2) and 33 (GPSW1)																																												
0	0																																													
0	1	use is dependent																																												
1	0	on application																																												
1	1																																													
AUFD "0F"	Automatic field detection: 0 = field selection by FSEL-bit 1 = automatic field detection by SAA7196																																													
FSEL	Field select (AUFD-bit = 0): 0 = 50 Hz (625 lines) 1 = 60 Hz (525 lines)																																													
SXCR	SECAM cross-colour reduction: 0 = reduction off 1 = reduction on																																													
SCEN	Enable sync and clamping pulse: 0 = HSY and HCL outputs HIGH (pins 25 and 26) 1 = HSY and HCL outputs active																																													
YDEL2 to YDEL0	Luminance delay compensation:  <table style="margin-left: auto; margin-right: auto;"> <tr> <td style="text-align: center;">YDEL2</td> <td style="text-align: center;">YDEL1</td> <td style="text-align: center;">YDEL0</td> <td style="text-align: center;">delay</td> <td></td> </tr> <tr> <td style="text-align: center;">0</td> <td style="text-align: center;">0</td> <td style="text-align: center;">0</td> <td style="text-align: center;">0 x 2 / LLC</td> <td></td> </tr> <tr> <td style="text-align: center;">0</td> <td style="text-align: center;">0</td> <td style="text-align: center;">1</td> <td style="text-align: center;">+1 x 2 / LLC</td> <td></td> </tr> <tr> <td style="text-align: center;">0</td> <td style="text-align: center;">1</td> <td style="text-align: center;">0</td> <td style="text-align: center;">+2 x 2 / LLC</td> <td style="text-align: right;">step size = 2 / LLC =</td> </tr> <tr> <td style="text-align: center;">0</td> <td style="text-align: center;">1</td> <td style="text-align: center;">1</td> <td style="text-align: center;">+3 x 2 / LLC</td> <td style="text-align: right;">67.8 ns for 50 Hz</td> </tr> <tr> <td style="text-align: center;">1</td> <td style="text-align: center;">0</td> <td style="text-align: center;">0</td> <td style="text-align: center;">-4 x 2 / LLC</td> <td style="text-align: right;">81.5 ns for 60 Hz</td> </tr> <tr> <td style="text-align: center;">1</td> <td style="text-align: center;">0</td> <td style="text-align: center;">1</td> <td style="text-align: center;">-3 x 2 / LLC</td> <td></td> </tr> <tr> <td style="text-align: center;">1</td> <td style="text-align: center;">1</td> <td style="text-align: center;">0</td> <td style="text-align: center;">-2 x 2 / LLC</td> <td></td> </tr> <tr> <td style="text-align: center;">1</td> <td style="text-align: center;">1</td> <td style="text-align: center;">1</td> <td style="text-align: center;">-1 x 2 / LLC</td> <td></td> </tr> </table>	YDEL2	YDEL1	YDEL0	delay		0	0	0	0 x 2 / LLC		0	0	1	+1 x 2 / LLC		0	1	0	+2 x 2 / LLC	step size = 2 / LLC =	0	1	1	+3 x 2 / LLC	67.8 ns for 50 Hz	1	0	0	-4 x 2 / LLC	81.5 ns for 60 Hz	1	0	1	-3 x 2 / LLC		1	1	0	-2 x 2 / LLC		1	1	1	-1 x 2 / LLC	
YDEL2	YDEL1	YDEL0	delay																																											
0	0	0	0 x 2 / LLC																																											
0	0	1	+1 x 2 / LLC																																											
0	1	0	+2 x 2 / LLC	step size = 2 / LLC =																																										
0	1	1	+3 x 2 / LLC	67.8 ns for 50 Hz																																										
1	0	0	-4 x 2 / LLC	81.5 ns for 60 Hz																																										
1	0	1	-3 x 2 / LLC																																											
1	1	0	-2 x 2 / LLC																																											
1	1	1	-1 x 2 / LLC																																											
HRFS "10"	Select HREF position: 0 = normal, HREF is matched to YUV output on Expansion Port 1 = HREF is matched to CVBS input port																																													

# Digital video decoder, scaler and clock generator circuit (DESCPro)

SAA7196

VNOI1 to VNOI0 "10"	Vertical noise reduction:  <table style="margin-left: auto; margin-right: auto;"> <thead> <tr> <th>VNOI1</th> <th>VNOI0</th> <th>mode</th> </tr> </thead> <tbody> <tr> <td>0</td> <td>0</td> <td>normal</td> </tr> <tr> <td>0</td> <td>1</td> <td>searching window</td> </tr> <tr> <td>1</td> <td>0</td> <td>free-running mode</td> </tr> <tr> <td>1</td> <td>1</td> <td>vertical noise reduction bypassed</td> </tr> </tbody> </table>	VNOI1	VNOI0	mode	0	0	normal	0	1	searching window	1	0	free-running mode	1	1	vertical noise reduction bypassed																																																									
VNOI1	VNOI0	mode																																																																							
0	0	normal																																																																							
0	1	searching window																																																																							
1	0	free-running mode																																																																							
1	1	vertical noise reduction bypassed																																																																							
CHCV7 to CHCV0 "11"	Chrominance gain control (nominal values) for QAM-modulated input signals, effects UV output amplitude (SECAM with fixed gain):  <table style="margin-left: auto; margin-right: auto;"> <thead> <tr> <th>D7</th> <th>D6</th> <th>D5</th> <th>D4</th> <th>D3</th> <th>D2</th> <th>D1</th> <th>D0</th> <th>gain</th> </tr> </thead> <tbody> <tr> <td>1</td> <td>1</td> <td>1</td> <td>1</td> <td>1</td> <td>1</td> <td>1</td> <td>1</td> <td>maximum gain</td> </tr> <tr> <td>:</td> <td>:</td> <td>:</td> <td>:</td> <td>:</td> <td>:</td> <td>:</td> <td>:</td> <td>to</td> </tr> <tr> <td>0</td> <td>1</td> <td>0</td> <td>1</td> <td>1</td> <td>0</td> <td>0</td> <td>1</td> <td>CCIR level for PAL</td> </tr> <tr> <td>:</td> <td>:</td> <td>:</td> <td>:</td> <td>:</td> <td>:</td> <td>:</td> <td>:</td> <td>to</td> </tr> <tr> <td>0</td> <td>0</td> <td>1</td> <td>0</td> <td>1</td> <td>1</td> <td>0</td> <td>0</td> <td>CCIR level for NTSC</td> </tr> <tr> <td>:</td> <td>:</td> <td>:</td> <td>:</td> <td>:</td> <td>:</td> <td>:</td> <td>:</td> <td>to</td> </tr> <tr> <td>0</td> <td>0</td> <td>0</td> <td>0</td> <td>0</td> <td>0</td> <td>0</td> <td>0</td> <td>minimum gain</td> </tr> </tbody> </table> <p style="text-align: right;">) default programmed values dependent on application</p>	D7	D6	D5	D4	D3	D2	D1	D0	gain	1	1	1	1	1	1	1	1	maximum gain	:	:	:	:	:	:	:	:	to	0	1	0	1	1	0	0	1	CCIR level for PAL	:	:	:	:	:	:	:	:	to	0	0	1	0	1	1	0	0	CCIR level for NTSC	:	:	:	:	:	:	:	:	to	0	0	0	0	0	0	0	0	minimum gain
D7	D6	D5	D4	D3	D2	D1	D0	gain																																																																	
1	1	1	1	1	1	1	1	maximum gain																																																																	
:	:	:	:	:	:	:	:	to																																																																	
0	1	0	1	1	0	0	1	CCIR level for PAL																																																																	
:	:	:	:	:	:	:	:	to																																																																	
0	0	1	0	1	1	0	0	CCIR level for NTSC																																																																	
:	:	:	:	:	:	:	:	to																																																																	
0	0	0	0	0	0	0	0	minimum gain																																																																	
SATN6 to SATN0 "12"	Chrominance saturation control for VRAM port:  <table style="margin-left: auto; margin-right: auto;"> <thead> <tr> <th>D7</th> <th>D6</th> <th>D5</th> <th>D4</th> <th>D3</th> <th>D2</th> <th>D1</th> <th>D0</th> <th>gain</th> </tr> </thead> <tbody> <tr> <td>0</td> <td>1</td> <td>1</td> <td>1</td> <td>1</td> <td>1</td> <td>1</td> <td>1</td> <td>1.999 (maximum saturation)</td> </tr> <tr> <td>:</td> <td>:</td> <td>:</td> <td>:</td> <td>:</td> <td>:</td> <td>:</td> <td>:</td> <td>to</td> </tr> <tr> <td>0</td> <td>1</td> <td>0</td> <td>0</td> <td>0</td> <td>0</td> <td>0</td> <td>0</td> <td>1 (CCIR level)</td> </tr> <tr> <td>:</td> <td>:</td> <td>:</td> <td>:</td> <td>:</td> <td>:</td> <td>:</td> <td>:</td> <td>to</td> </tr> <tr> <td>0</td> <td>0</td> <td>0</td> <td>0</td> <td>0</td> <td>0</td> <td>0</td> <td>0</td> <td>0 (colour off)</td> </tr> </tbody> </table>	D7	D6	D5	D4	D3	D2	D1	D0	gain	0	1	1	1	1	1	1	1	1.999 (maximum saturation)	:	:	:	:	:	:	:	:	to	0	1	0	0	0	0	0	0	1 (CCIR level)	:	:	:	:	:	:	:	:	to	0	0	0	0	0	0	0	0	0 (colour off)																		
D7	D6	D5	D4	D3	D2	D1	D0	gain																																																																	
0	1	1	1	1	1	1	1	1.999 (maximum saturation)																																																																	
:	:	:	:	:	:	:	:	to																																																																	
0	1	0	0	0	0	0	0	1 (CCIR level)																																																																	
:	:	:	:	:	:	:	:	to																																																																	
0	0	0	0	0	0	0	0	0 (colour off)																																																																	
CONT6 to CONT0 "13"	Luminance contrast control for VRAM port:  <table style="margin-left: auto; margin-right: auto;"> <thead> <tr> <th>D7</th> <th>D6</th> <th>D5</th> <th>D4</th> <th>D3</th> <th>D2</th> <th>D1</th> <th>D0</th> <th>gain</th> </tr> </thead> <tbody> <tr> <td>0</td> <td>1</td> <td>1</td> <td>1</td> <td>1</td> <td>1</td> <td>1</td> <td>1</td> <td>1.999 (maximum contrast)</td> </tr> <tr> <td>:</td> <td>:</td> <td>:</td> <td>:</td> <td>:</td> <td>:</td> <td>:</td> <td>:</td> <td>to</td> </tr> <tr> <td>0</td> <td>1</td> <td>0</td> <td>0</td> <td>0</td> <td>0</td> <td>0</td> <td>0</td> <td>1 (CCIR level)</td> </tr> <tr> <td>:</td> <td>:</td> <td>:</td> <td>:</td> <td>:</td> <td>:</td> <td>:</td> <td>:</td> <td>to</td> </tr> <tr> <td>0</td> <td>0</td> <td>0</td> <td>0</td> <td>0</td> <td>0</td> <td>0</td> <td>0</td> <td>0 (luminance off)</td> </tr> </tbody> </table>	D7	D6	D5	D4	D3	D2	D1	D0	gain	0	1	1	1	1	1	1	1	1.999 (maximum contrast)	:	:	:	:	:	:	:	:	to	0	1	0	0	0	0	0	0	1 (CCIR level)	:	:	:	:	:	:	:	:	to	0	0	0	0	0	0	0	0	0 (luminance off)																		
D7	D6	D5	D4	D3	D2	D1	D0	gain																																																																	
0	1	1	1	1	1	1	1	1.999 (maximum contrast)																																																																	
:	:	:	:	:	:	:	:	to																																																																	
0	1	0	0	0	0	0	0	1 (CCIR level)																																																																	
:	:	:	:	:	:	:	:	to																																																																	
0	0	0	0	0	0	0	0	0 (luminance off)																																																																	
HS6B7 to HS6B0 "14"	Horizontal sync begin for 60 Hz, step size = 2 / LLC. The delay time is selectable from -382/LLC (+191 decimal multiplier) to +128/LLC (-64 decimal multiplier) equals data BF to C0 (hex). Two's complement numbers with "hidden" sign-bit. The sign-bit is generated internally by evaluating the MSB and the MSB-1 bits.																																																																								
HS6S7 to HS6S0 "15"	Horizontal sync stop for 60 Hz, step size = 2 / LLC. The delay time is selectable from -382/LLC (+191 decimal multiplier) to +128/LLC (-64 decimal multiplier) equals data BF to C0 (hex). Two's complement numbers with "hidden" sign-bit. The sign-bit is generated internally by evaluating the MSB and the MSB-1 bits.																																																																								
HC6B7 to HC6B0 "16"	Horizontal clamp begin for 60 Hz, step size = 2 / LLC. The delay time is selectable from -254/LLC (+127 decimal multiplier) to +256/LLC (-128 decimal multiplier) equals data 7F to 80 (hex).																																																																								

# Digital video decoder, scaler and clock generator circuit (DESCPro)

SAA7196

<p>HC6S7 to HC6S0 "17"</p>	<p>Horizontal clamp stop for 60 Hz, step size = 2 / LLC. The delay time is selectable from -254/ LLC (+127 decimal multiplier) to +256/LLC (-128 decimal multiplier) equals data 7F to 80 (hex).</p>																																																						
<p>HP6I7 to HP6I0 "18"</p>	<p>Horizontal sync start after PHI1 for 60 Hz, step size = 8 / LLC. The delay time is selectable from -32 to +31.7 <math>\mu</math>s (+97 to -97 decimal multiplier) equals data 61 to 9F (hex).</p> <p>Forbidden, outside available central counter range, are +127 to +98 decimal multiplier equals data 7E to 62 (hex) as well as -98 to -128 decimal multiplier equals data 9E to 80 (hex).</p>																																																						
<p>BRIG7 to BRIG0 "19"</p>	<p>Luminance brightness control for VRAM port:</p> <table style="margin-left: auto; margin-right: auto;"> <tr> <td style="text-align: center;">D7</td><td style="text-align: center;">D6</td><td style="text-align: center;">D5</td><td style="text-align: center;">D4</td><td style="text-align: center;">D3</td><td style="text-align: center;">D2</td><td style="text-align: center;">D1</td><td style="text-align: center;">D0</td><td style="text-align: right;">gain</td> </tr> <tr> <td style="text-align: center;">1</td><td style="text-align: center;">1</td><td style="text-align: center;">1</td><td style="text-align: center;">1</td><td style="text-align: center;">1</td><td style="text-align: center;">1</td><td style="text-align: center;">1</td><td style="text-align: center;">1</td><td style="text-align: right;">255 (bright)</td> </tr> <tr> <td style="text-align: center;">:</td><td style="text-align: center;">:</td><td style="text-align: center;">:</td><td style="text-align: center;">:</td><td style="text-align: center;">:</td><td style="text-align: center;">:</td><td style="text-align: center;">:</td><td style="text-align: center;">:</td><td style="text-align: right;">to</td> </tr> <tr> <td style="text-align: center;">1</td><td style="text-align: center;">0</td><td style="text-align: center;">0</td><td style="text-align: center;">0</td><td style="text-align: center;">0</td><td style="text-align: center;">0</td><td style="text-align: center;">0</td><td style="text-align: center;">0</td><td style="text-align: right;">128 (CCIR level)</td> </tr> <tr> <td style="text-align: center;">:</td><td style="text-align: center;">:</td><td style="text-align: center;">:</td><td style="text-align: center;">:</td><td style="text-align: center;">:</td><td style="text-align: center;">:</td><td style="text-align: center;">:</td><td style="text-align: center;">:</td><td style="text-align: right;">to</td> </tr> <tr> <td style="text-align: center;">0</td><td style="text-align: center;">0</td><td style="text-align: center;">0</td><td style="text-align: center;">0</td><td style="text-align: center;">0</td><td style="text-align: center;">0</td><td style="text-align: center;">0</td><td style="text-align: center;">0</td><td style="text-align: right;">0 (dark)</td> </tr> </table>	D7	D6	D5	D4	D3	D2	D1	D0	gain	1	1	1	1	1	1	1	1	255 (bright)	:	:	:	:	:	:	:	:	to	1	0	0	0	0	0	0	0	128 (CCIR level)	:	:	:	:	:	:	:	:	to	0	0	0	0	0	0	0	0	0 (dark)
D7	D6	D5	D4	D3	D2	D1	D0	gain																																															
1	1	1	1	1	1	1	1	255 (bright)																																															
:	:	:	:	:	:	:	:	to																																															
1	0	0	0	0	0	0	0	128 (CCIR level)																																															
:	:	:	:	:	:	:	:	to																																															
0	0	0	0	0	0	0	0	0 (dark)																																															

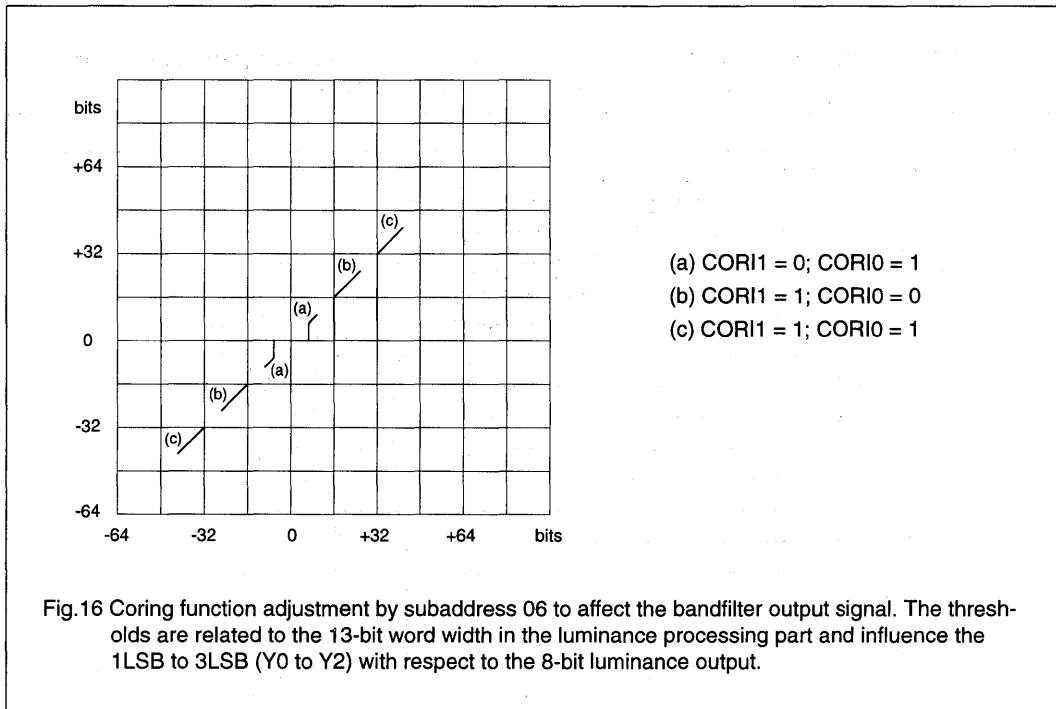

Digital video decoder, scaler  
and clock generator circuit (DESCPro)

SAA7196

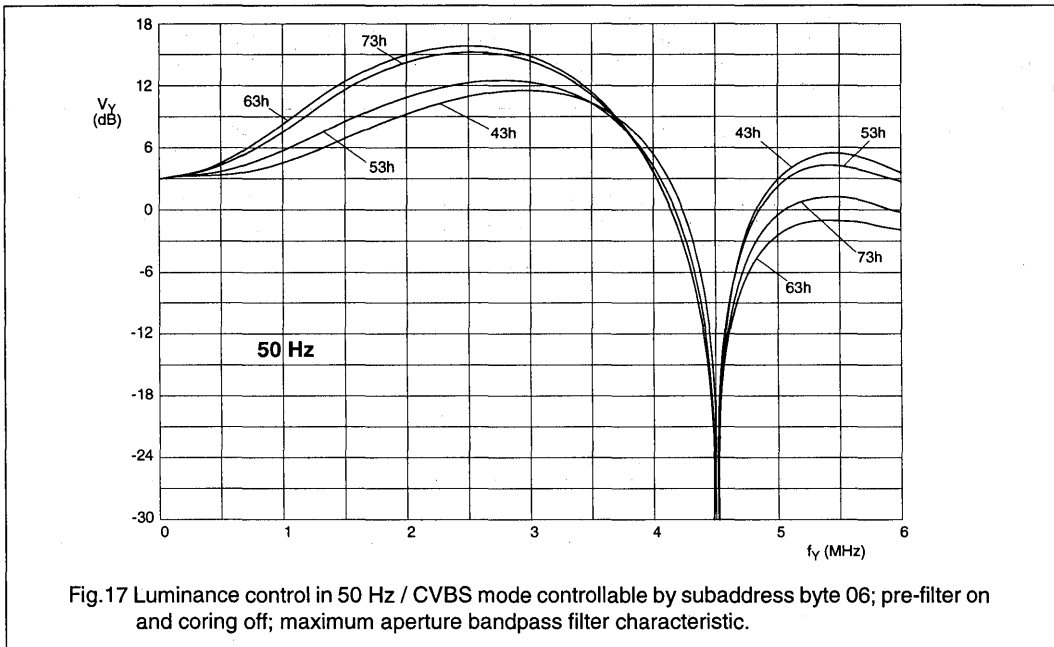

Fig.17 Luminance control in 50 Hz / CVBS mode controllable by subaddress byte 06; pre-filter on and coring off; maximum aperture bandpass filter characteristic.

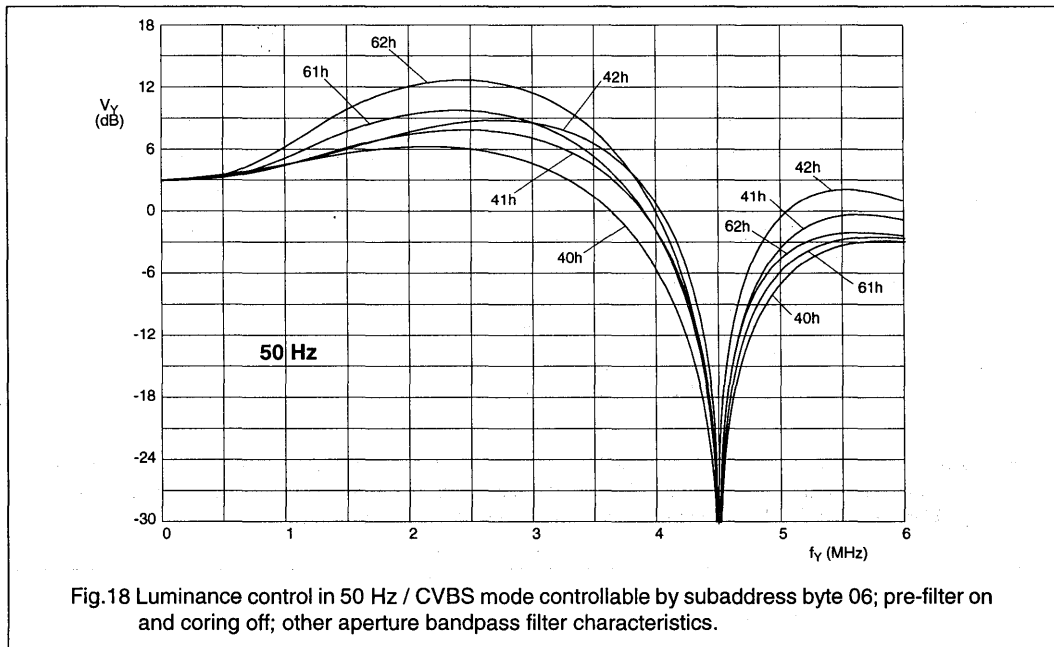
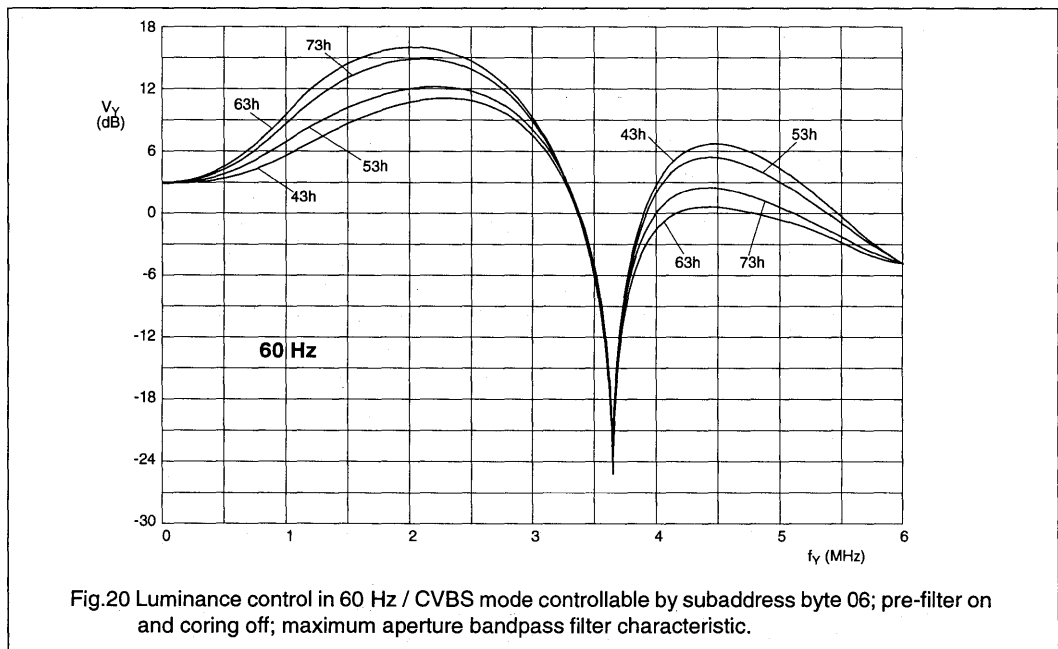
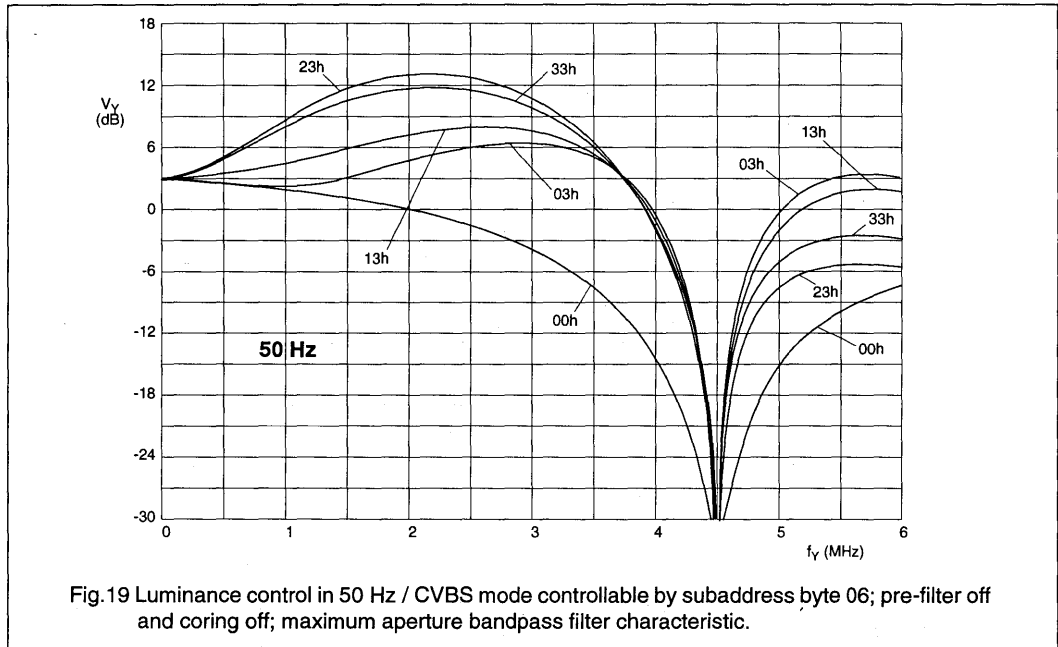

Fig.18 Luminance control in 50 Hz / CVBS mode controllable by subaddress byte 06; pre-filter on and coring off; other aperture bandpass filter characteristics.



Digital video decoder, scaler  
and clock generator circuit (DESCPro)

SAA7196



Digital video decoder, scaler  
and clock generator circuit (DESCPro)

SAA7196

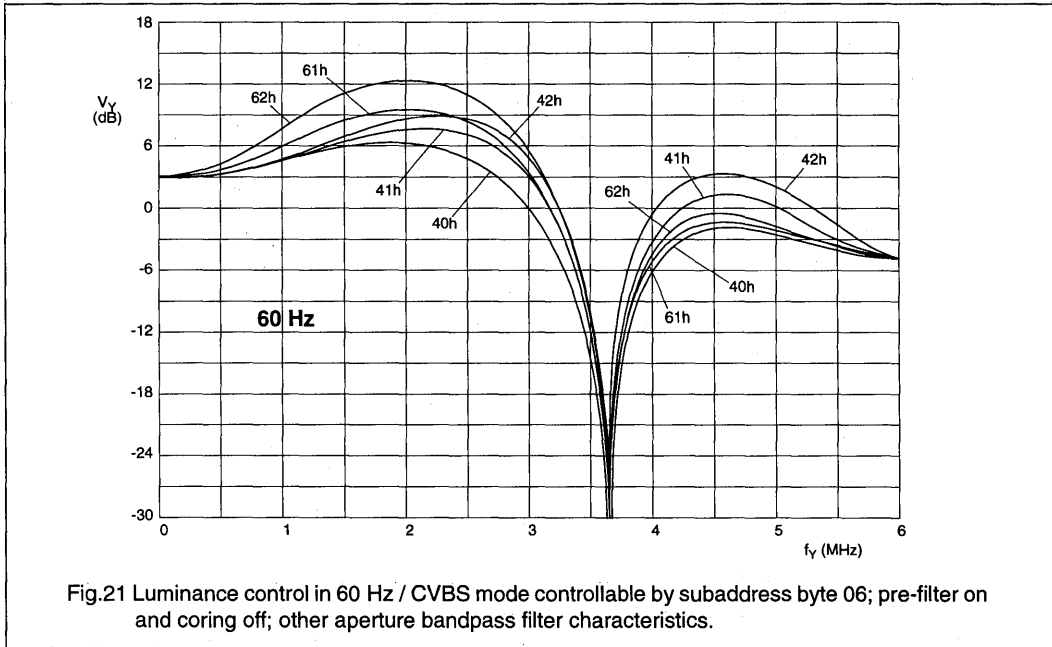

Fig.21 Luminance control in 60 Hz / CVBS mode controllable by subaddress byte 06; pre-filter on and coring off; other aperture bandpass filter characteristics.

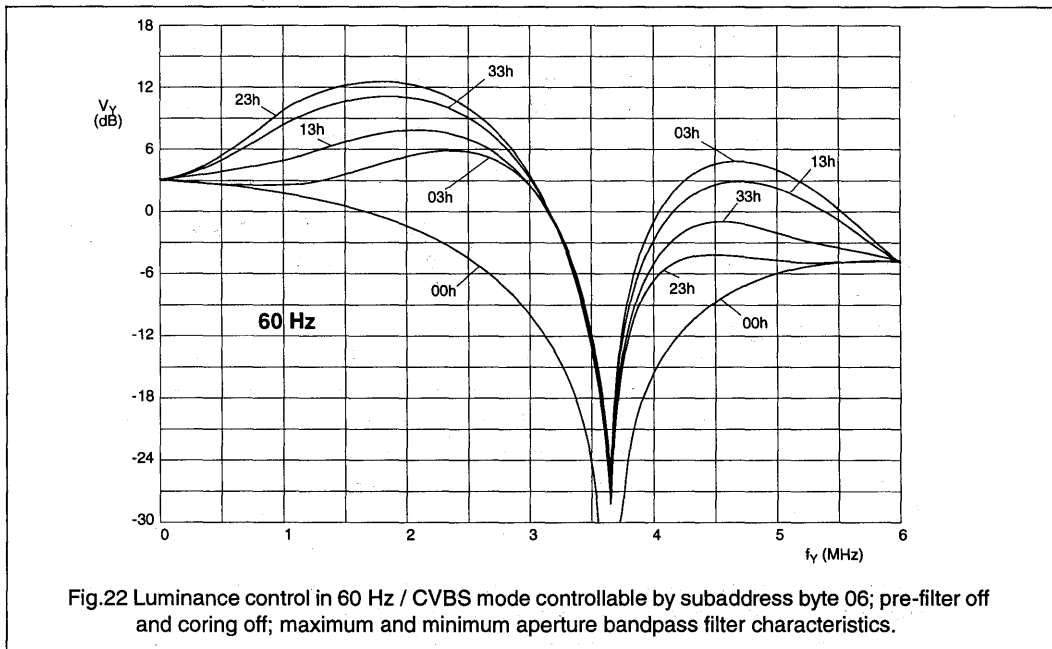
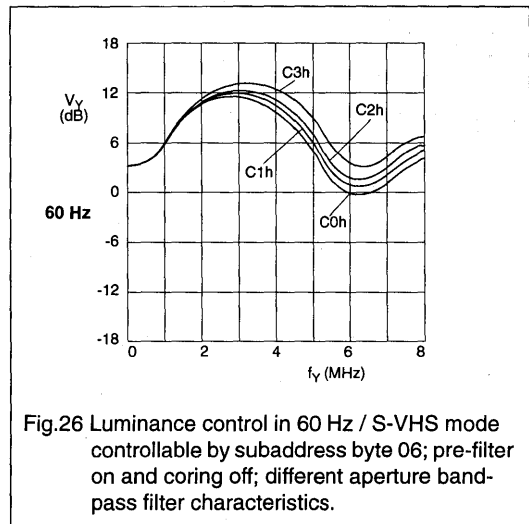
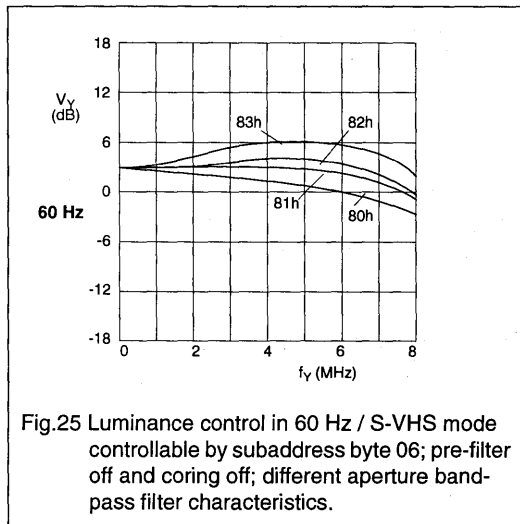
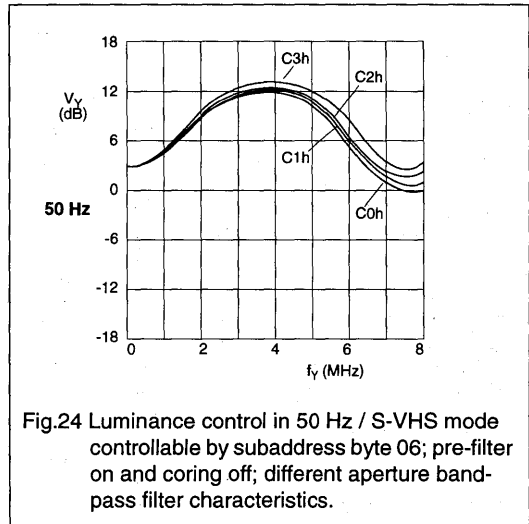
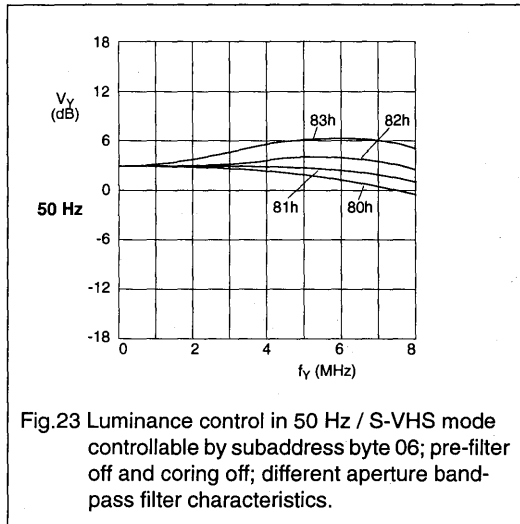

Fig.22 Luminance control in 60 Hz / CVBS mode controllable by subaddress byte 06; pre-filter off and coring off; maximum and minimum aperture bandpass filter characteristics.

# Digital video decoder, scaler and clock generator circuit (DESCPro)

SAA7196



# Digital video decoder, scaler and clock generator circuit (DESCPro)

SAA7196

**Table 11** I<sup>2</sup>C-bus scaler control; subaddress and data bytes for writing

FUNCTION SUBADDRESS		DATA								DF*
		D7	D6	D5	D4	D3	D2	D1	D0	
Formats and sequence	20	RTB	OF1	OF0	VPE	LW1	LW0	FS1	FS0	
Output data pixel/line (1)	21	XD7	XD6	XD5	XD4	XD3	XD2	XD1	XD0	
Input data pixel/line (1)	22	XS7	XS6	XS5	XS4	XS3	XS2	XS1	XS0	
Horiz. window start (1)	23	XO7	XO6	XO5	XO4	XO3	XO2	XO1	XO0	
Horizontal filter	24	HF2	HF1	HF0	XO8	XS9	XS8	XD9	XD8	
Output data lines/field (2)	25	YD7	YD6	YD5	YD4	YD3	YD2	YD1	YD0	
Input data lines/field (2)	26	YS7	YS6	YS5	YS4	YS3	YS2	YS1	YS0	
Vertical window start (2)	27	YO7	YO6	YO5	YO4	YO3	YO2	YO1	YO0	
AFS/vertical Y processing	28	AFS	VP1	VP0	YO8	YS9	YS8	YD9	YD8	
Vertical bypass start (3)	29	VS7	VS6	VS5	VS4	VS3	VS2	VS1	VS0	
Vertical bypass count (3)	2A	VC7	VC6	VC5	VC4	VC3	VC2	VC1	VC0	
	2B	0	0	0	VS8	0	VC8	0	POE	
Chroma keying lower limit for V	2C	VL7	VL6	VL5	VL4	VL3	VL2	VL1	VL0	
upper limit for V	2D	VU7	VU6	VU5	VU4	VU3	VU2	VU1	VU0	
lower limit for U	2E	UL7	UL6	UL5	UL4	UL3	UL2	UL1	UL0	
upper limit for U	2F	UU7	UU6	UU5	UU4	UU3	UU2	UU1	UU0	
Data path setting **	30	VOF	AFG	LLV	MCT	QPL	QPP	TTR	EFE	
unused	31 to 3F									

(1) continued in "24"; (2) continued in "28"; (3) continued in "2B";

\*) Default register contents fill in by hand;

\*\*) Data representation, transfer mode and adaptivity

**Table 12** Function of the register bits of Table 11 for subaddresses "20" to "30"

RTB "20"	ROM table bypass switch: 0 = anti-gamma ROM active 1 = table is bypassed															
OF1 to OF0	Set output field mode:  <table border="0"> <tr> <td>OF1</td> <td>OF0</td> <td>field mode DVS process</td> </tr> <tr> <td>0</td> <td>0</td> <td>both fields for interlaced storage</td> </tr> <tr> <td>0</td> <td>1</td> <td>both fields for non-interlaced storage</td> </tr> <tr> <td>1</td> <td>0</td> <td>odd fields only (even fields ignored) for non-interlaced storage</td> </tr> <tr> <td>1</td> <td>1</td> <td>even fields only (odd fields ignored) for non-interlaced storage</td> </tr> </table>	OF1	OF0	field mode DVS process	0	0	both fields for interlaced storage	0	1	both fields for non-interlaced storage	1	0	odd fields only (even fields ignored) for non-interlaced storage	1	1	even fields only (odd fields ignored) for non-interlaced storage
OF1	OF0	field mode DVS process														
0	0	both fields for interlaced storage														
0	1	both fields for non-interlaced storage														
1	0	odd fields only (even fields ignored) for non-interlaced storage														
1	1	even fields only (odd fields ignored) for non-interlaced storage														
VPE	VRAM port outputs enable: 0 = HFL and INCADR inactive (HFL = LOW, INCADR = HIGH); VRO outputs in 3-state 1 = HFL and INCADR enabled; VRO outputs dependent on VOEN															

Digital video decoder, scaler  
and clock generator circuit (DESCPro)

SAA7196

<p>LW1 to LW0 "20"</p>	<p>First pixel position in VRO data for FS1 = 0; FS0 = 0 (RGB) and FS1 = 0; FS0 = 1 (YUV):</p> <table border="1" style="margin-left: 40px;"> <thead> <tr> <th>LW1</th> <th>LW0</th> <th>31 to 24</th> <th>23 to 16</th> <th>15 to 8</th> <th>7 to 0</th> <th></th> </tr> </thead> <tbody> <tr> <td>0</td> <td>0</td> <td>pixel 0</td> <td>pixel 0</td> <td>pixel 1</td> <td>pixel 1</td> <td>)</td> </tr> <tr> <td>0</td> <td>1</td> <td>pixel 0</td> <td>pixel 0</td> <td>pixel 1</td> <td>pixel 1</td> <td>)</td> </tr> <tr> <td>1</td> <td>0</td> <td>black</td> <td>black</td> <td>pixel 0</td> <td>pixel 0</td> <td>)</td> </tr> <tr> <td>1</td> <td>1</td> <td>black</td> <td>black</td> <td>pixel 0</td> <td>pixel 0</td> <td>)</td> </tr> </tbody> </table> <p style="text-align: right;">EFE = 0; TTR = 0</p> <p>First pixel position in VRO data for FS1 = 1; FS0 = 1 (monochrome):</p> <table border="1" style="margin-left: 40px;"> <thead> <tr> <th>LW1</th> <th>LW0</th> <th>31 to 24</th> <th>23 to 16</th> <th>15 to 8</th> <th>7 to 0</th> <th></th> </tr> </thead> <tbody> <tr> <td>0</td> <td>0</td> <td>pixel 0</td> <td>pixel 1</td> <td>pixel 2</td> <td>pixel 3</td> <td>)</td> </tr> <tr> <td>0</td> <td>1</td> <td>black</td> <td>pixel 0</td> <td>pixel 1</td> <td>pixel 2</td> <td>)</td> </tr> <tr> <td>1</td> <td>0</td> <td>black</td> <td>black</td> <td>pixel 0</td> <td>pixel 1</td> <td>)</td> </tr> <tr> <td>1</td> <td>1</td> <td>black</td> <td>black</td> <td>black</td> <td>pixel 0</td> <td>)</td> </tr> <tr> <td>0</td> <td>0</td> <td>pixel 0</td> <td>pixel 1</td> <td>X</td> <td>X</td> <td>)</td> </tr> <tr> <td>0</td> <td>1</td> <td>black</td> <td>pixel 0</td> <td>X</td> <td>X</td> <td>)</td> </tr> <tr> <td>1</td> <td>0</td> <td>pixel 0</td> <td>pixel 1</td> <td>X</td> <td>X</td> <td>)</td> </tr> <tr> <td>1</td> <td>1</td> <td>black</td> <td>pixel 0</td> <td>X</td> <td>X</td> <td>)</td> </tr> </tbody> </table> <p style="text-align: right;">EFE = 0; TTR = 0 EFE = 1; TTR = 0; LW only effects the grayscale format</p>	LW1	LW0	31 to 24	23 to 16	15 to 8	7 to 0		0	0	pixel 0	pixel 0	pixel 1	pixel 1	)	0	1	pixel 0	pixel 0	pixel 1	pixel 1	)	1	0	black	black	pixel 0	pixel 0	)	1	1	black	black	pixel 0	pixel 0	)	LW1	LW0	31 to 24	23 to 16	15 to 8	7 to 0		0	0	pixel 0	pixel 1	pixel 2	pixel 3	)	0	1	black	pixel 0	pixel 1	pixel 2	)	1	0	black	black	pixel 0	pixel 1	)	1	1	black	black	black	pixel 0	)	0	0	pixel 0	pixel 1	X	X	)	0	1	black	pixel 0	X	X	)	1	0	pixel 0	pixel 1	X	X	)	1	1	black	pixel 0	X	X	)
LW1	LW0	31 to 24	23 to 16	15 to 8	7 to 0																																																																																														
0	0	pixel 0	pixel 0	pixel 1	pixel 1	)																																																																																													
0	1	pixel 0	pixel 0	pixel 1	pixel 1	)																																																																																													
1	0	black	black	pixel 0	pixel 0	)																																																																																													
1	1	black	black	pixel 0	pixel 0	)																																																																																													
LW1	LW0	31 to 24	23 to 16	15 to 8	7 to 0																																																																																														
0	0	pixel 0	pixel 1	pixel 2	pixel 3	)																																																																																													
0	1	black	pixel 0	pixel 1	pixel 2	)																																																																																													
1	0	black	black	pixel 0	pixel 1	)																																																																																													
1	1	black	black	black	pixel 0	)																																																																																													
0	0	pixel 0	pixel 1	X	X	)																																																																																													
0	1	black	pixel 0	X	X	)																																																																																													
1	0	pixel 0	pixel 1	X	X	)																																																																																													
1	1	black	pixel 0	X	X	)																																																																																													
<p>FS1 to FS0</p>	<p>FIFO output register format select (EFE-bit see "30"):</p> <table border="1" style="margin-left: 40px;"> <thead> <tr> <th>EFE</th> <th>FS1</th> <th>FS0</th> <th>output format (Tables 5 and 6)</th> </tr> </thead> <tbody> <tr> <td>0</td> <td>0</td> <td>0</td> <td>RGB 5-5-5 + alpha; 2 x 16-bit/pixel; 32-bit word length; RGB matrix on, VRAM output format</td> </tr> <tr> <td>0</td> <td>0</td> <td>1</td> <td>YUV 4:2:2; 2 x 16-bit/pixel; 32-bit word length; RGB matrix off, VRAM output format</td> </tr> <tr> <td>0</td> <td>1</td> <td>0</td> <td>YUV 4:2:2; 1 x 16-bit/pixel; 16-bit word length; RGB matrix off, optional output format</td> </tr> <tr> <td>0</td> <td>1</td> <td>1</td> <td>monochrome mode; 4 x 8-bit/pixel; 32-bit word length; RGB matrix off, VRAM output format</td> </tr> <tr> <td>1</td> <td>0</td> <td>0</td> <td>RGB 5-5-5 + alpha; 1 x 16-bit/pixel; 16-bit word length; RGB matrix on, VRAM output + transparent format</td> </tr> <tr> <td>1</td> <td>0</td> <td>1</td> <td>YUV 4:2:2 + alpha; 1 x 16-bit/pixel; 16-bit word length; RGB matrix off; VRAM output + transparent format</td> </tr> <tr> <td>1</td> <td>1</td> <td>0</td> <td>RGB 8-8-8 + alpha; 1 x 24-bit/pixel; 24-bit word length; RGB matrix on, VRAM output + transparent format</td> </tr> <tr> <td>1</td> <td>1</td> <td>1</td> <td>monochrome mode; 2 x 8-bit/pixel; 16-bit word length; RGB matrix off, VRAM output + transparent format</td> </tr> </tbody> </table>	EFE	FS1	FS0	output format (Tables 5 and 6)	0	0	0	RGB 5-5-5 + alpha; 2 x 16-bit/pixel; 32-bit word length; RGB matrix on, VRAM output format	0	0	1	YUV 4:2:2; 2 x 16-bit/pixel; 32-bit word length; RGB matrix off, VRAM output format	0	1	0	YUV 4:2:2; 1 x 16-bit/pixel; 16-bit word length; RGB matrix off, optional output format	0	1	1	monochrome mode; 4 x 8-bit/pixel; 32-bit word length; RGB matrix off, VRAM output format	1	0	0	RGB 5-5-5 + alpha; 1 x 16-bit/pixel; 16-bit word length; RGB matrix on, VRAM output + transparent format	1	0	1	YUV 4:2:2 + alpha; 1 x 16-bit/pixel; 16-bit word length; RGB matrix off; VRAM output + transparent format	1	1	0	RGB 8-8-8 + alpha; 1 x 24-bit/pixel; 24-bit word length; RGB matrix on, VRAM output + transparent format	1	1	1	monochrome mode; 2 x 8-bit/pixel; 16-bit word length; RGB matrix off, VRAM output + transparent format																																																														
EFE	FS1	FS0	output format (Tables 5 and 6)																																																																																																
0	0	0	RGB 5-5-5 + alpha; 2 x 16-bit/pixel; 32-bit word length; RGB matrix on, VRAM output format																																																																																																
0	0	1	YUV 4:2:2; 2 x 16-bit/pixel; 32-bit word length; RGB matrix off, VRAM output format																																																																																																
0	1	0	YUV 4:2:2; 1 x 16-bit/pixel; 16-bit word length; RGB matrix off, optional output format																																																																																																
0	1	1	monochrome mode; 4 x 8-bit/pixel; 32-bit word length; RGB matrix off, VRAM output format																																																																																																
1	0	0	RGB 5-5-5 + alpha; 1 x 16-bit/pixel; 16-bit word length; RGB matrix on, VRAM output + transparent format																																																																																																
1	0	1	YUV 4:2:2 + alpha; 1 x 16-bit/pixel; 16-bit word length; RGB matrix off; VRAM output + transparent format																																																																																																
1	1	0	RGB 8-8-8 + alpha; 1 x 24-bit/pixel; 24-bit word length; RGB matrix on, VRAM output + transparent format																																																																																																
1	1	1	monochrome mode; 2 x 8-bit/pixel; 16-bit word length; RGB matrix off, VRAM output + transparent format																																																																																																
<p>XD9 to XD0 "21 and 24"</p>	<p>Pixel number per line (straight binary) on output (VRO): 00 0000 0000 to 11 1111 1111 (number of XS pixels as a maximum; take care of vertical processing)</p>																																																																																																		
<p>XS9 to XS0 "22 and 24"</p>	<p>Pixel number per line (straight binary) on inputs (YIN and UVIN): 00 0000 0000 to 11 1111 1111 (number of input pixels per line as a maximum; take care of vertical processing)</p>																																																																																																		
<p>XO8 to XO0 "23 and 24"</p>	<p>Horizontal start position (straight binary) of scaling window (take care of active pixel number per line): start with 1st pixel after HREF rise = 0 0000 0011 to 1 1111 1111 (003 to 1FF) Window start and window end may be cut by internal delay compensated HREF = 0 phase.</p>																																																																																																		

Digital video decoder, scaler  
and clock generator circuit (DESCPro)

SAA7196

HF2 to HF0 "24"	Horizontal decimation filter:																																													
	<table border="1"> <thead> <tr> <th>HF2</th> <th>HF1</th> <th>HF0</th> <th>taps</th> <th>filter (Figures 27 and 28 on page 46)</th> </tr> </thead> <tbody> <tr> <td>0</td> <td>0</td> <td>0</td> <td>2</td> <td>filter 1</td> </tr> <tr> <td>0</td> <td>0</td> <td>1</td> <td>3</td> <td>filter 2</td> </tr> <tr> <td>0</td> <td>1</td> <td>0</td> <td>5</td> <td>filter 3</td> </tr> <tr> <td>0</td> <td>1</td> <td>1</td> <td>9</td> <td>filter 4</td> </tr> <tr> <td>1</td> <td>0</td> <td>0</td> <td>1</td> <td>filter bypassed</td> </tr> <tr> <td>1</td> <td>0</td> <td>1</td> <td>1</td> <td>filter bypassed + delay in Y channel of 1T</td> </tr> <tr> <td>1</td> <td>1</td> <td>0</td> <td>8</td> <td>filter 5</td> </tr> <tr> <td>1</td> <td>1</td> <td>1</td> <td>4</td> <td>filter 6</td> </tr> </tbody> </table> <p>The filter coefficients are related to the luminance path. The filter coefficient may differ from upper table when a combination with vertical Y processing and adaptive modes are provided.</p>	HF2	HF1	HF0	taps	filter (Figures 27 and 28 on page 46)	0	0	0	2	filter 1	0	0	1	3	filter 2	0	1	0	5	filter 3	0	1	1	9	filter 4	1	0	0	1	filter bypassed	1	0	1	1	filter bypassed + delay in Y channel of 1T	1	1	0	8	filter 5	1	1	1	4	filter 6
HF2	HF1	HF0	taps	filter (Figures 27 and 28 on page 46)																																										
0	0	0	2	filter 1																																										
0	0	1	3	filter 2																																										
0	1	0	5	filter 3																																										
0	1	1	9	filter 4																																										
1	0	0	1	filter bypassed																																										
1	0	1	1	filter bypassed + delay in Y channel of 1T																																										
1	1	0	8	filter 5																																										
1	1	1	4	filter 6																																										
YD9 to "25 and 28"	YD0 Line number per output field (straight binary): 00 0000 0000 to 11 1111 1111 (number of YS lines as a maximum)																																													
YS9 to "26 and 28"	YS0 Line number per input field (straight binary): 00 0000 0000 0 line 11 1111 1111 1023 lines (maximum = number of lines/field - 3)																																													
Y08 to "27 and 28"	Y00 Vertical start of scaling window. Take care of active line number per field (straight binary); window start and window end may be cut by the external VS signal: 0 0000 0000 start with 3rd line after the rising slope of VS 0 0000 0011 start with 1st line after the falling slope of nominal VS (7151B, 7191B input) 1 1111 1111 511 + 3 lines after the rising slope of VS (maximum value)																																													
AFS "28"	Adaptive filter switch: 0 = off; use VP1, VP0 and HF2 to HF0 bits 1 = on; filter characteristics are selected by the scaler																																													
VP1 to VP0	Vertical luminance data processing: <table border="1"> <thead> <tr> <th>VP1</th> <th>VP0</th> <th>processing (approximate equations)</th> </tr> </thead> <tbody> <tr> <td>0</td> <td>0</td> <td>bypassed</td> </tr> <tr> <td>0</td> <td>1</td> <td>delay of one line <math>H(z) = z^{-1}</math></td> </tr> <tr> <td>1</td> <td>0</td> <td>vertical filter 1: <math>H(z) = 1/2 (1 + z^{-1})</math></td> </tr> <tr> <td>1</td> <td>1</td> <td>vertical filter 2: <math>H(z) = 1/4 (1 + 2z^{-1} + z^{-2})</math></td> </tr> </tbody> </table>	VP1	VP0	processing (approximate equations)	0	0	bypassed	0	1	delay of one line $H(z) = z^{-1}$	1	0	vertical filter 1: $H(z) = 1/2 (1 + z^{-1})$	1	1	vertical filter 2: $H(z) = 1/4 (1 + 2z^{-1} + z^{-2})$																														
VP1	VP0	processing (approximate equations)																																												
0	0	bypassed																																												
0	1	delay of one line $H(z) = z^{-1}$																																												
1	0	vertical filter 1: $H(z) = 1/2 (1 + z^{-1})$																																												
1	1	vertical filter 2: $H(z) = 1/4 (1 + 2z^{-1} + z^{-2})$																																												
VS8 to "29 and 2B"	VS0 Vertical bypass start, sets begin of the bypass region (straight binary). Scaling region overrides bypass region (YO bits): 0 0000 0000 start with 3rd line after the rising slope of VS 0 0000 0011 start with 1st line after the falling slope of nominal VS (7151B, 7191B input) 1 1111 1111 511 + 3 lines after the rising slope of VS (maximum value)																																													
VC8 to "2A and 2B"	VC0 Vertical bypass count, sets length of bypass region (straight binary): 0 0000 0000 0 line length 1 1111 1111 511 lines length (maximum = number of lines/field - 3)																																													
POE	Polarity, internally detected odd/even flag O/E: 0 = flag unchanged 1 = flag inverted																																													

# Digital video decoder, scaler and clock generator circuit (DESCPro)

SAA7196

VL7 to VL0 "2C"	Set lower limit V for colour-keying (8 bit; two's complement): 1000 0000 as maximum negative value = -128 signal level 0000 0000 limit = 0; 0111 1111 as maximum positive value = +127 signal level
VU7 to VU0 "2D"	Set upper limit V for colour-keying (8 bit; two's complement): 1000 0000 as maximum negative value = -128 signal level 0000 0000 limit = 0 0111 1111 as maximum positive value = +127 signal level
UL7 to UL0 "2E"	Set lower limit U for colour-keying (8 bit; two's complement): 1000 0000 as maximum negative value = -128 signal level 0000 0000 limit = 0 0111 1111 as maximum positive value = +127 signal level
UU7 to UU0 "2F"	Set upper limit U for colour-keying (8 bit; two's complement): 1000 0000 as maximum negative value = -128 signal level 0000 0000 limit = 0 0111 1111 as maximum positive value = +127 signal level
VOF "30"	VRAM bus output format: 0 = enabling of 32 to 16 bit multiplexing via VMUX (pin 46) 1 = disabling of 32 to 16 bit multiplexing via VMUX (pin 46)
AFG	Adaptive geometrical filter: 0 = linear H and V data processing 1 = approximated geometrical H and V interpolation (improved scaling accuracy of luminance)
LLV	Luminance limiting value: 0 = amplitude range between 1 and 254 1 = amplitude range between 16 and 235, suitable for monochrome and YUV modes
MCT	Monochrome and two's complement output data select: 0 = inverse grayscale luminance (if grayscale is selected by FS bits) or straight binary U, V data output 1 = non-inverse monochrome luminance (if grayscale is selected by FS bits) or two's complement U, V data output
QPL	Line qualifier polarity flag: 0 = LNQ is active-LOW (pin 52) 1 = LNQ is active-HIGH
QPP	Pixel qualifier polarity flag: 0 = PXQ is active-LOW (pin 51) 1 = PXQ is active-HIGH
TTR	Transparent data transfer: 0 = normal operation (VRAM data burst transfer) 1 = FIFO register transparent
EFE	Extended formats enable bit (see FS-bits in subaddress "20"): 0 = 32-bit longword output formats 1 = extended output formats ("one pixel a time")

Digital video decoder, scaler  
and clock generator circuit (DESCPro)

SAA7196

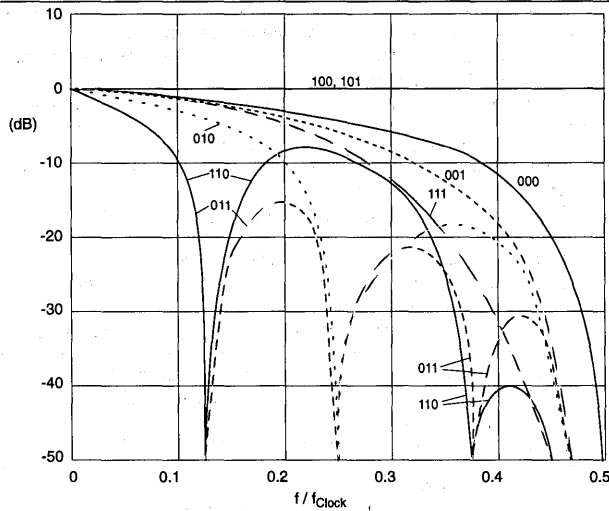

Fig.27 Horizontal frequency characteristic of luminance signal (Y) dependent on HF2 to HF0 bits (subaddress 24).

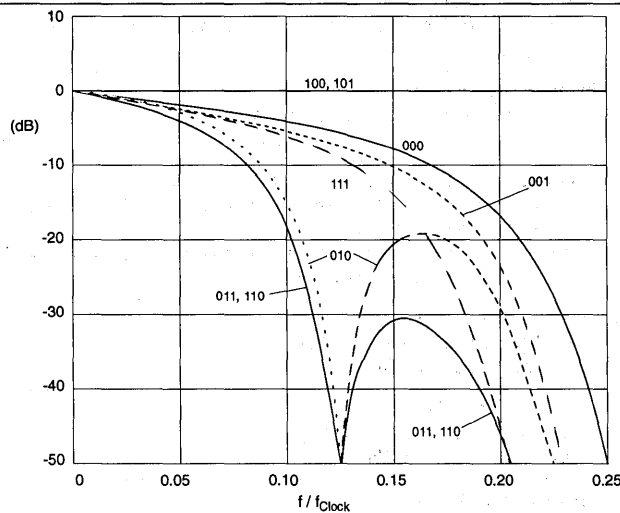

Fig.28 Horizontal frequency characteristic of chrominance signals (UV) without UV interpolation dependent on HF2 to HF0 bits (subaddresses 24).



Purchase of Philips' I<sup>2</sup>C components conveys a license under the Philips' I<sup>2</sup>C patent to use the components in the I<sup>2</sup>C-system provided the system conforms to the I<sup>2</sup>C specifications defined by Philips.



# Digital video decoder, scaler and clock generator circuit (DESCPro)

SAA7196

## 9. LIMITING VALUES

In accordance with the Absolute Maximum Rating System (IEC 134).

SYMBOL	PARAMETER	MIN.	MAX.	UNIT
$V_{DD}$	supply voltage (pins 14, 27, 31, 45, 61, 77, 91 and 106)	-0.5	6.5	V
$V_I$	voltage on all input/output pins	-0.5	$V_{DD}+0.5V$	
$P_{tot}$	total power dissipation	-	1.5	W
$T_{stg}$	storage temperature range	-65	150	°C
$T_{amb}$	operating ambient temperature range	0	70	°C
$V_{ESD}$	electrostatic handling* for all pins	-	±2000	V

\*) Equivalent to discharging a 100 pF capacitor through a 1.5 kΩ series resistor.

## 10. CHARACTERISTICS

$V_{DD} = 4.5$  to  $5.5$  V;  $T_{amb} = 0$  to  $70$  °C unless otherwise specified.

SYMBOL	PARAMETER	CONDITIONS	MIN.	TYP.	MAX.	UNIT
$V_{DDD}$	digital supply voltage range (pins 14, 31, 45, 61, 77, 91 and 106)		4.5	5	5.5	V
$V_{DDA}$	analog supply voltage range (pin 27)		4.5	5	5.5	V
$I_{DDD}$	digital supply current	inputs LOW; outputs without load	-	170	260	mA
$I_{DDA}$	analog supply current		-	10	20	mA
<b>Data, clock and control inputs</b>						
$V_{IL}$	input voltage LOW	clocks	-0.5	-	0.6	V
$V_{IH}$	input voltage HIGH	clocks	2.4	-	$V_{DD}+0.5$	V
$V_{iL}$	input voltage LOW	other inputs	-0.5	-	0.8	V
$V_{iH}$	input voltage HIGH	other inputs	2.0	-	$V_{DD}+0.5$	V
$I_{Li}$	input leakage current	$V_{iL} = 0$	-	-	10	μA
$C_i$	input capacitance data		-	-	8	pF
	input capacitance clocks		-	-	10	pF
	input capacitance 3-state I/O	high-impedance state	-	-	8	pF
<b>Data and control outputs</b> note 1						
$V_{OL}$	output voltage LOW		0	-	0.6	V
$V_{OH}$	output voltage HIGH		2.4	-	$V_{DD}$	V
<b>LFCO output (pin 28)</b>						
$V_o$	LFCO output signal (peak-to-peak value)		1.4	2.1	2.6	V
$V_{28}$	output voltage range		1	-	$V_{DD}$	V
<b>I<sup>2</sup>C-bus, SDA and SCL (pins 3 and 4)</b>						
$V_{iL}$	input voltage LOW		-0.5	-	1.5	V
$V_{iH}$	input voltage HIGH		3	-	$V_{DD}+0.5$	V

# Digital video decoder, scaler and clock generator circuit (DESCPro)

SAA7196

SYMBOL	PARAMETER	CONDITIONS	MIN.	TYP.	MAX.	UNIT
$I_{3,4}$	input current		-	-	$\pm 10$	$\mu\text{A}$
$I_{ACK}$	output current on pin 3	acknowledge	3	-	-	mA
$V_{OL}$	output voltage at acknowledge	$I_3 = 3 \text{ mA}$	-	-	0.4	V
<b>Clock input timing (LLCB)</b>		Fig.30				
$t_{LLCB}$	cycle time		31	-	45	ns
$\delta$	duty factor	$t_{LLCBH}/t_{LLCB}$	40	50	60	%
$t_r$	rise time		-	-	5	ns
$t_f$	fall time		-	-	6	ns
<b>Data, control and CREFB input timing</b>		Fig.30 and Fig.31	; note 2			
$t_{SU}$	set-up time		11	-	-	ns
$t_{HD}$	hold-time		4	-	-	ns
<b>Data and control output timing</b>		Fig.30	; note 3			
$C_L$	load capacitance	data, HREF and VS	15	-	50	pF
		control	7.5	-	25	pF
$t_{OH}$	output hold time	$C_L = 15 \text{ pF}$	13	-	-	ns
$t_{PD}$	propagation delay from negative edge of LLCB	data, HREF and VS; $C_L = 50 \text{ pF}$	-	-	29	ns
		control; $C_L = 25 \text{ pF}$	-	-	29	ns
$t_{PZ}$	propagation delay from negative edge of LLCB (to 3-state)	note 4	-	-	15	ns
<b>Clock output timing (LLC, LLC2, LLCB)</b>		Fig.30				
$C_L$	output load capacitance		15	-	40	pF
$t_{LLC}, t_{LLCB}$	cycle time		31	-	45	ns
$t_{LLC2}$	cycle time		62	-	90	ns
$\delta$	duty factor	$t_{LLCH}/t_{LLC}$ $t_{LLC2H}/t_{LLC2}$ $t_{LLCBH}/t_{LLCB}$	40	50	60	%
$t_r$	rise time	0.6 to 2.6 V	-	-	5	ns
$t_f$	fall time	2.6 to 0.6 V	-	-	5	ns
$t_{dLLC2}$	delay between LLCB <sub>out</sub> and LLC2 <sub>out</sub>	at 1.5 V, 40 pF	-	-	8	ns
<b>Data qualifier output timing (CREFB)</b>		Fig.30				
$t_{OH}$	output hold time	$C_L = 15 \text{ pF}$	3	-	-	ns
$t_{PD}$	propagation delay from positive edge of LLCB	$C_L = 40 \text{ pF}$	-	-	18	ns
<b>Horizontal PLL</b>						
$f_{Hn}$	nominal line frequency	50 Hz system	-	15625	-	Hz
		60 Hz system	-	15734	-	Hz
$\Delta f_H/f_{Hn}$	permissible static deviation	50 Hz system	-	-	$\pm 5.6$	%
		60 Hz system	-	-	$\pm 6.7$	%

# Digital video decoder, scaler and clock generator circuit (DESCPro)

SAA7196

SYMBOL	PARAMETER	CONDITIONS	MIN.	TYP.	MAX.	UNIT
<b>Subcarrier PLL</b>						
$f_{SCn}$	nominal subcarrier frequency	PAL	-	4.433618	-	MHz
		NTSC	-	3.579545	-	MHz
$\Delta f_{SC}$	lock-in range	PAL/NTSC	$\pm 400$	-	-	Hz
<b>Crystal oscillator</b>		Fig.32	; note 11			
$f_n$	nominal frequency	3rd harmonic	-	26.8	-	MHz
$\Delta f / f_n$	permissible deviation $f_n$		-	-	$\pm 50$	$10^{-6}$
	temperature deviation from $f_n$		-	-	$\pm 20$	$10^{-6}$
X1	crystal specification:					
	temperature range $T_{amb}$		0	-	70	$^{\circ}C$
	load capacitance $C_L$		8	-	-	pF
	series resonance resistance $R_S$		-	50	80	$\Omega$
	motional capacitance $C_1$		-	$1.1 \pm 20\%$	-	fF
	parallel capacitance $C_0$		-	$3.5 \pm 20\%$	-	pF
	Philips catalogue number		9922 520 30004			
<b>VCLK timing</b>		Fig.29	; note 12			
$t_{VCLK}$	VRAM port clock cycle time	note 5	50	-	200	ns
$t_{pL}, t_{pH}$	LOW and HIGH times	note 6	17	-	-	ns
$t_r$	rise time		-	-	5	ns
$t_f$	fall time		-	-	6	ns
<b>VRO and reference signal output timing</b>		Fig.29				
$C_L$	output load capacitance	VRO outputs	15	-	40	pF
		other outputs	7.5	-	25	pF
$t_{OH}$	VRO data hold time	$C_L = 10$ pF; note 7	0	-	-	ns
$t_{OHL}$	related to LCCB (INCADR, HFL)	$C_L = 10$ pF; note 8	0	-	-	ns
$t_{OHV}$	related to VCLK (HFL)	$C_L = 10$ pF; note 8	0	-	-	ns
$t_{OD}$	VRO data delay time	$C_L = 40$ pF; note 7	-	-	25	ns
$t_{ODL}$	related to LCCB (INCADR, HFL)	$C_L = 25$ pF; note 8	-	-	60	ns
$t_{ODV}$	related to VCLK (HFL)	$C_L = 25$ pF; note 8	-	-	60	ns
$t_D$	VRO disable time to 3-state	$C_L = 40$ pF; note 9	-	-	40	ns
		$C_L = 25$ pF; note 10	-	-	24	ns
$t_E$	VRO enable time from 3-state	$C_L = 40$ pF; note 9	-	-	40	ns
		$C_L = 25$ pF; note 10	-	-	25	ns
<b>Response times to HFL flag</b>						
$t_{HFL\ VOE}$	HFL rising edge to VRAM port enable		-	-	810	ns
$t_{HFL\ VCLK}$	HFL rising edge to VCLK burst		-	-	840	ns

# Digital video decoder, scaler and clock generator circuit (DESCPro)

SAA7196

### Notes to the characteristics

- Levels measured with load circuits dependent on output type. Control outputs (HREF, VS excluded): 1.2 kΩ at 3 V (TTL load) and  $C_L = 25$  pF. Data, HREF and VS outputs: 1.2 kΩ at 3 V (TTL load) and  $C_L = 50$  pF.
- Data input signals are CVBS(7-0), CHR(7-0) (related to LLC) and YUV(15-0). Control input signals are HREF, VS and DIR.
- Data outputs are YUV(15-0). Control outputs are HREF, VS, HS, HSY, HCL, SODD, SVS, SHREF, PXQ, LNQ, RTCO and RTS(1-0).
- The minimum propagation delay from 3-state to data active is 0 related to the falling edge of LLCB.
- Maximum  $t_{VCLK} = 200$  ns for test mode only. The applicable maximum cycle time depends on data format, horizontal scaling and input data rate.
- Measured at 1.5 V level;  $t_{pL}$  may be infinite.
- Timings of VRO refer to the rising edge of VCLK.
- The timing of INCADR refers to LLCB; the rising edge of HFL always refers to LLCB. During a VRAM transfer, the falling edge of HFL is generated by VCLK. Both edges of HFL refer to LLCB during horizontal increment and vertical reset cycles.
- Asynchronous signals. Its timing refers to the 1.5 V switching point of VOEN input signal (pin 53).
- The timing refers to the 1.5 V switching point of VMUX signal (pin 46) in 32- to 16-bit multiplexing mode. Corresponding pairs of VRO outputs are together connected.
- If the internal oscillator is not being used, the applied clock signal must be TTL-compatible.
- CREFB-timing also valid for VCLK in transparent mode (see Fig.30).

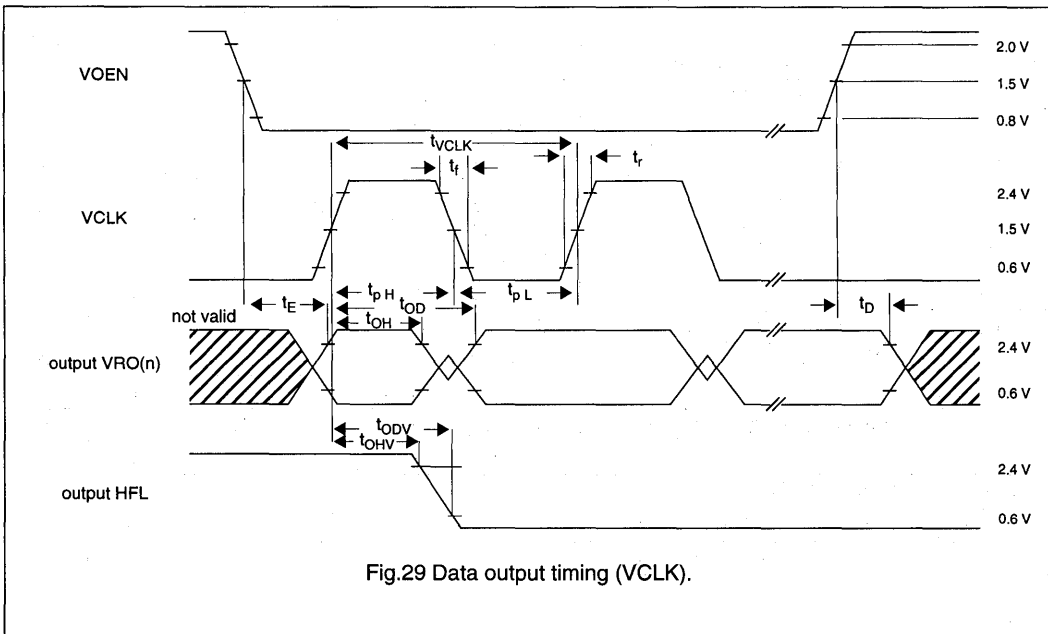

Digital video decoder, scaler  
and clock generator circuit (DESCPro)

SAA7196

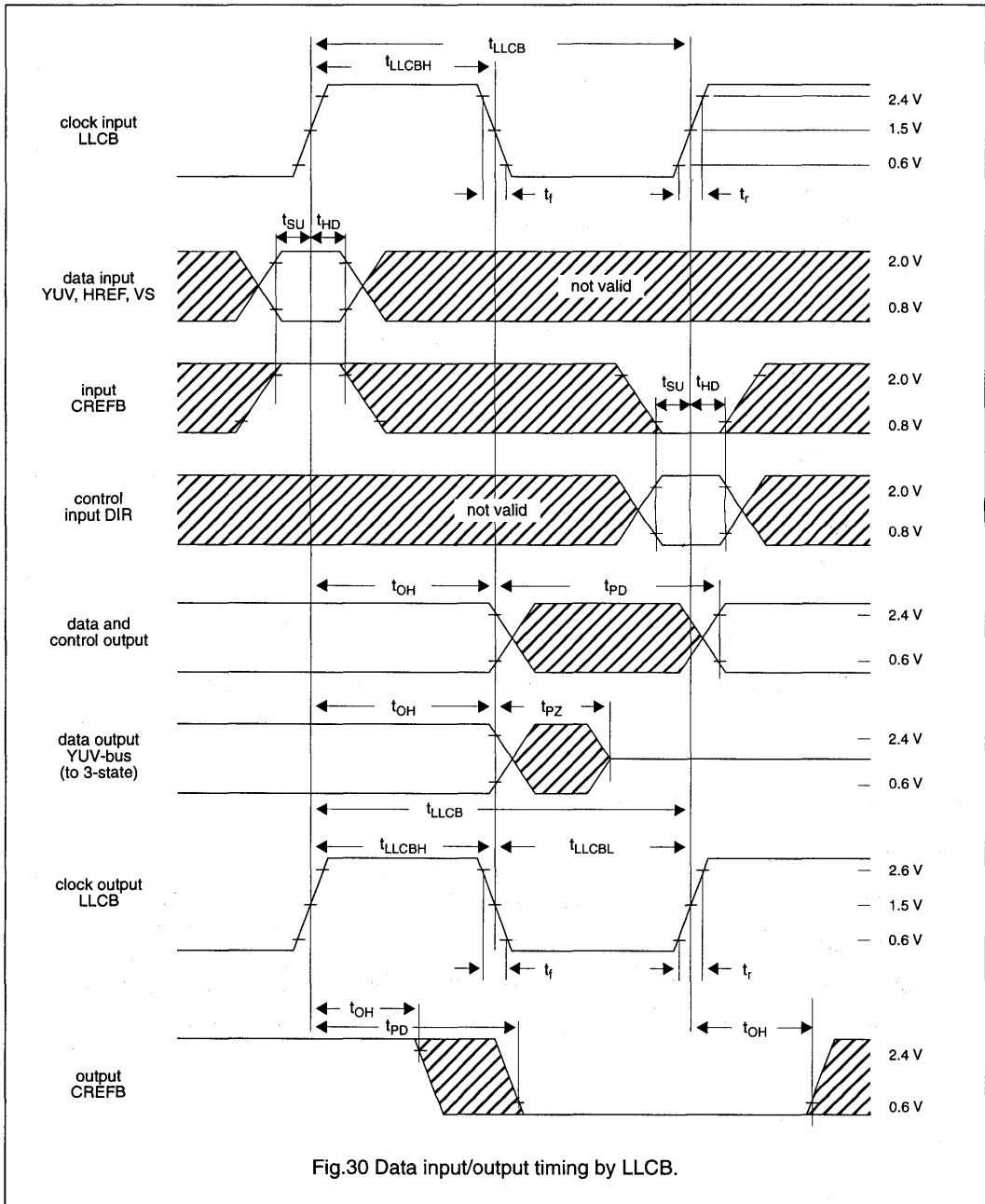

Digital video decoder, scaler  
and clock generator circuit (DESCPro)

SAA7196

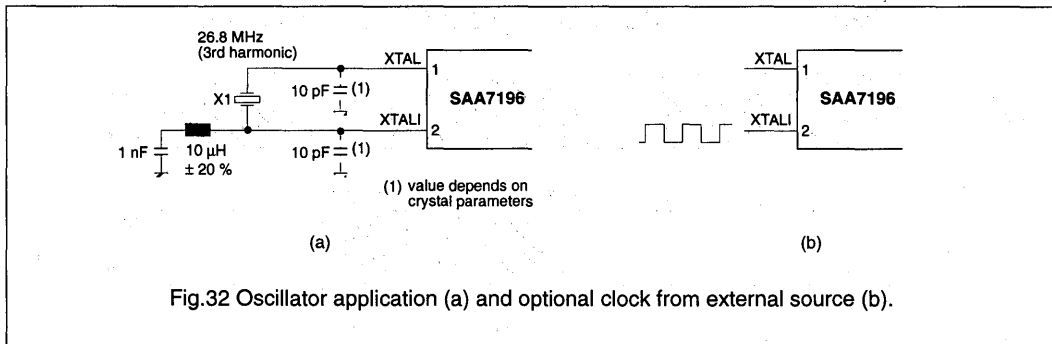
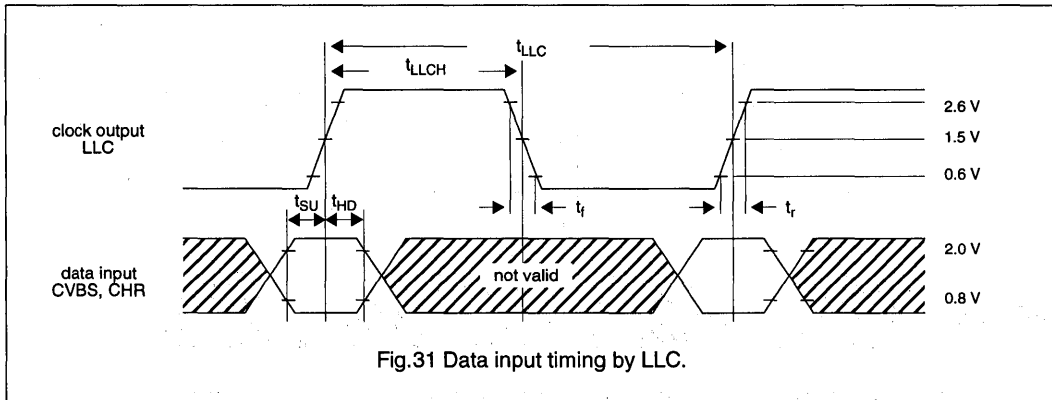

11. PROCESSING DELAYS

Table 13 Processing delays of signals

PORTS	DELAY IN LLC/LLCB CYCLES	REMARKS
CVBS/CHR to YUV	216	-
YUV to VRO	56 in YUV mode; 58 in RGB mode	only in transparent mode
CVBS/CHR to VRO	272 in YUV mode; 274 in RGB modes	only in transparent mode

# Digital video decoder, scaler and clock generator circuit (DESCPro)

SAA7196

## 12. APPLICATION INFORMATION

### 12.1. CIRCUIT DIAGRAM

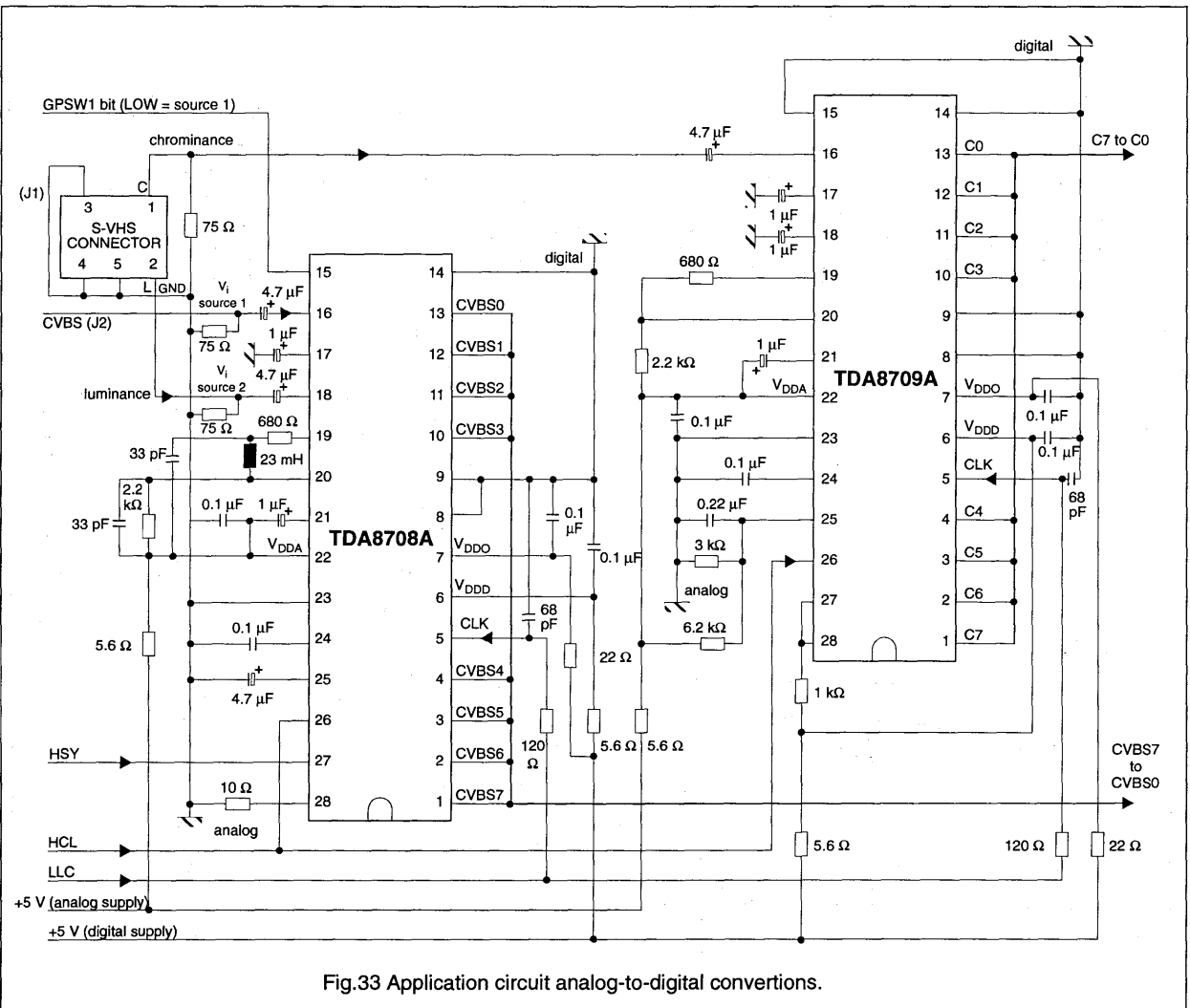

Fig.33 Application circuit analog-to-digital conversions.

# Digital video decoder, scaler and clock generator circuit (DESCPro)

SAA7196

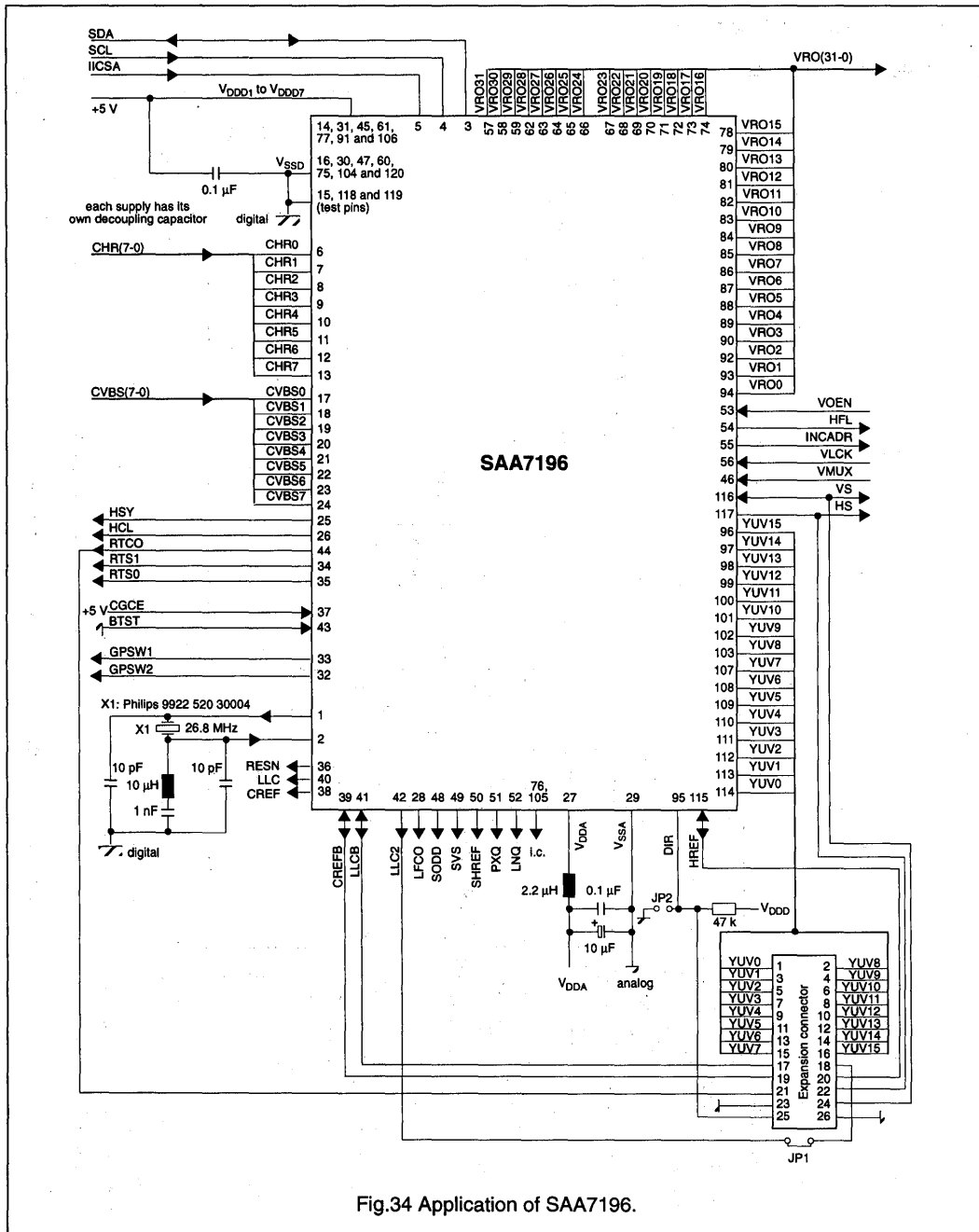

Fig.34 Application of SAA7196.



# Digital video decoder, scaler and clock generator circuit (DESCPro)

SAA7196

## 12.2. PROGRAMMING EXAMPLE

Coefficients to set operation for application circuits Figures 33 and 34 on page 53 and page 54. Slave address byte is 40 h at pin 5 connected to  $V_{SSD}$  (or 42 h at pin 5 connected to  $V_{DDD}$ )

Table 14 Programming examples

SUBADDRESS	BITS	FUNCTION	VALUE (hex)
00	IDEL(7:0)	increment delay	4C
01	HSYB(7:0)	H-sync beginning for 50 Hz	30
02	HSYS(7:0)	H-sync stop for 50 Hz	00
03	HCLB(7:0)	H-clamp beginning for 50 Hz	E8
04	HCLS(7:0)	H-clamp stop for 50 Hz	B6
05	HPhi(7:0)	HS pulse position for 50 Hz	F4
06	BYPS, PREF, BPSS(1:0), CORI(1:0), APER(1:0)	luminance bandwidth control	01(1)
07	HUEC(7:0)	hue control (0 degree)	00
08	CKTQ(4:0)	colour-killer threshold QUAM	F8
09	CKTS(4:0)	colour-killer threshold SECAM	F8
0A	PLSE(7:0)	PAL-switch sensitivity	40
0B	SESE(7:0)	SECAM switch sensitivity	40
0C	COLO, LFIS(1:0)	chrominance gain control settings	00
0D	VTRC, RTSE, HRMV, SSTB, SECS	standard/mode control	04 (2)(4); 05 (3)(4)
0E	HPLL, OECL, OEHV, OEYC, CHR5, GPSW(2:1)	I/O and clock controls	38, 3B (5)
0F	AUFD, FSEL, SXCR, SCEN, YDEL(2:0)	miscellaneous controls #1	90
10	HRFS, VNOI(1:0)	miscellaneous controls #2	00
11	CHCV(7:0)	chrominance gain nominal value	2C (6); 59 (7)
12	SATN(6:0)	chrominance saturation control value	40
13	CONT(6:0)	luminance contrast control value	40
14	HS6B(7:0)	H-sync beginning for 60 Hz	34
15	HS6S(7:0)	H-sync stop for 60 Hz	0A
16	HC6B(7:0)	H-clamp beginning for 60 Hz	F4
17	HC6S(7:0)	H-clamp stop for 60 Hz	CE
18	HP6I(7:0)	HS pulse position for 60 Hz	F4
19	BRIG(7:0)	luminance brightness control value	80
1A to 1F	reserved	set to zero	00
20	RTB, OF(1:0), VPE, LW(1:0), FS(1:0)	data formats and field sequence processing	10 (8)
21	XD(7:0)	LSB's output pixel/line	80 (9); FF (13)
22	XS(7:0)	LSB's input pixel/line	80 (9); FF (13)
23	XO(7:0)	LSB's for horizontal window start position	03 (9); 00 (13)
24	HF(2:0), XO(8), XS(9,8), XD(9,8)	horizontal filter select and MSB's of subaddresses 21, 22, 23	85 (9); 8F (13)

# Digital video decoder, scaler and clock generator circuit (DESCPro)

SAA7196

SUBADDRESS	BITS	FUNCTION	VALUE (hex)
25	YD(7:0)	LSB's output lines/field	90 (9); FF (13)
26	YS(7:0)	LSB's input lines/field	90 (9); FF (13)
27	YO(7:0)	LSB's vertical window start position	03 (9); 00 (13)
28	AFS, VP(1:0), YO(8), YS(9,8), YD(9,8)	adaptive and vertical filter select and MSB's of subaddresses 25, 26, 27	00 (9); 0F (13)
29	VS(7:0)	LSB's vertical bypass start position	00 (10)
2A	VC(7:0)	LSB's vertical bypass lines/field	00 (10)
2B	VS(8), VC(8), POE	MSB's of subaddresses 29, 2A and odd/even polarity switch	00 (10)
2C	VL(7:0)	chroma key: lower limit V (R-Y)	00
2D	VU(7:0)	chroma key: upper limit V (R-Y)	FF (11)
2E	UL(7:0)	chroma key: lower limit U (B-Y)	00
2F	UU(7:0)	chroma key: upper limit U (B-Y)	00
30	VOF, AFG	VRAM port MUX enable, adaptivity	80 (12)

## Notes to Table 14

- dependent on application (Figures 33 and 34 on page 53 and page 54)
- for QUAM standards
- for SECAM
- HPLL is in TV-mode, value for VCR-mode is 84h (85h for SECAM VCR-mode)
- for Y/C-mode
- nominal value for UV-CCIR-level with NTSC source
- nominal value for UV-CCIR-level with PAL source
- ROM-table is active, scaler processes both fields for interlaced display; VRAM port enabled; longword position = 0; 16-bit 4:2:2 YUV output format selected
- scaler processes a segment of (384 pixels x 144 lines) with defaults XO and YO set to the first valid pixel/line and line/field (for decoder as input source) with scaler factors of 1:1; horizontal and vertical filters are bypassed, filter select adaptivity is disabled
- no vertical bypass region is defined
- chrominance keyer is disabled (VL = 0, VU = -1)
- 32-bit to 16 VRAM port MUX, adaptive scale and Y-limiter are disabled; pixel and line qualifier polarity for transparent mode are set to zero (active); data burst transfer for the 32-bit longword formats is set
- if no scaling and panning is wanted, the parameters XD, XS, YD and YS should be set to maximum (3FFh) and the parameters XO and YO should be set to minimum (000h). In this case, the HREF and VS signals define the processing window of the scaler

# Clock signal generator circuit for Desktop Video systems (SCGC)

SAA7197

## FEATURES

- Suitable for Desktop Video systems
- Two different sync sources selectable
- PLL frequency multiplier to generate 4 times of input frequency
- Dividers to generate clocks LLCA, LLCB, LLC2A and LLC2B (2nd and 4th multiples of input frequency)
- PLL mode or VCO mode selectable
- Reset control and power fail detection

## QUICK REFERENCE DATA

SYMBOL	PARAMETER	MIN.	TYP.	MAX.	UNIT
V <sub>DDA</sub>	analog supply voltage (pin 5)	4.5	5.0	5.5	V
V <sub>DDD</sub>	digital supply voltage (pins 8, 17)	4.5	5.0	5.5	V
I <sub>DDA</sub>	analog supply current	5	-	9	mA
I <sub>DDD</sub>	digital supply current	10	-	60	mA
V <sub>LF</sub> CO	LFCO input voltage (peak-to-peak value)	1	-	V <sub>DDA</sub>	V
f <sub>i</sub>	input frequency range	6.0	-	7.2	MHz
V <sub>I</sub>	input voltage LOW input voltage HIGH	0 2.4	- -	0.8 V <sub>DDD</sub>	V V
V <sub>O</sub>	output voltage LOW output voltage HIGH	0 2.6	- -	0.6 V <sub>DDD</sub>	V V
T <sub>amb</sub>	operating ambient temperature range	0	-	70	°C

## GENERAL DESCRIPTION

The SAA7197 generates all clock signals required for a digital TV system suitable for the SAA719x family. The circuit operates in either the phase-locked loop mode (PLL) or voltage controlled oscillator mode (VCO).

## ORDERING INFORMATION

EXTENDED TYPE NUMBER	PACKAGE			
	PINS	PIN POSITION	MATERIAL	CODE
SAA7197	20	DIL	plastic	SOT146
SAA7197T	20	mini-pack (SO20)	plastic	SOT163A

# Clock signal generator circuit for Desktop Video systems (SCGC)

SAA7197

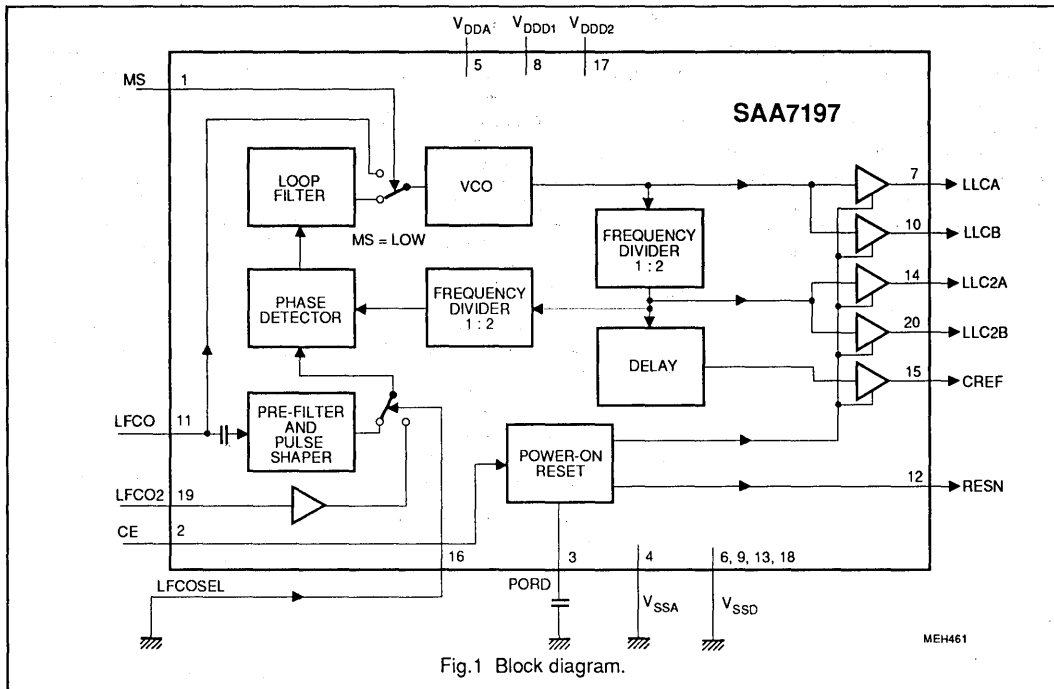

## FUNCTION DESCRIPTION

The SAA7197 generates all clock signals required for a digital TV system suitable for the SAA719x family consisting of an 8-bit analog-to-digital converter (ADC8), digital video multistandard decoder, square pixel (DMSD-SQP), digital video colour space converter (DCSC) and optional extensions. The SAA7197 completes a system for Desktop Video applications in conjunction with memory controllers.

The input signal LFCO is a digital-to-analog converted signal provided by the DMDS-SQPs horizontal PLL. It is the multiple of the line frequency:

$$7.38 \text{ MHz} = 472 \times f_H \text{ in } 50 \text{ Hz systems}$$

$$6.14 \text{ MHz} = 360 \times f_H \text{ in } 60 \text{ Hz systems}$$

LFCO2 (TTL-compatible signal from an external reference source) can be applied to pin 19 (LFCOSEL = HIGH).

The input signal LFCO or LFCO2 is

multiplied by factors 2 or 4 in the PLL (including phase detector, loop filter, VCO and frequency divider) and output on LLCA (pin 7), LLCB (pin 10), LLC2A (pin 14) and LLC2B (pin 20). The rectangular output signals have 50 % duty factor. Outputs with equal frequency may be connected together externally. The clock outputs go HIGH during power-on reset (and chip enable) to ensure that no output clock signals are available the PLL has locked-on.

### Mode select MS

The LFCO input signal is directly connected to the VCO at MS = HIGH. The circuit operates as an oscillator and frequency divider. This function is not tested.

### Source select LFCOSEL

Line frequency control signal LFCO (pin 11) is selected by LFCOSEL = LOW. LFCOSEL = HIGH selects LFCO2 input signal (pin 19). This function is not tested.

### Chip enable CE

The buffer outputs are enabled and RESN set HIGH by CE = HIGH (Fig.4). CE = LOW sets the clock outputs HIGH and RESN output LOW.

### CREF output

$2 f_{LFCO}$  output to control the clock dividers of the DMDS-SQP chip family.

### Power-on reset

Power-on reset is activated at power-on, when the supply voltage decreases below 3.5 V (Fig.4) or when chip enable is done. The indicator output RESN is LOW for a time determined by capacitor on pin 3. The RESN signal can be applied to reset other circuits of this digital TV system.

The LFCO or LFCO2 input signals have to be applied before RESN becomes HIGH.

# Clock signal generator circuit for Destop Video systems (SCGC)

SAA7197

## PINNING

SYMBOL	PIN	DESCRIPTION
MS	1	mode select input (LOW = PLL mode)*
CE	2	chip enable /reset (HIGH = outputs enabled)
PORD	3	power-on reset delay, dependent on external capacitor
V <sub>SSA</sub>	4	analog ground (0 V)
V <sub>DDA</sub>	5	analog supply voltage (+5 V)
V <sub>SSD1</sub>	6	digital ground 1 (0 V)
LLCA	7	line-locked clock output signal (4 times $f_{LFCO}$ )
V <sub>DDD1</sub>	8	digital supply voltage 1 (+5 V)
V <sub>SSD2</sub>	9	digital ground 2 (0 V)
LLCB	10	line-locked clock output signal (4 times $f_{LFCO}$ )
LFCO	11	line-locked frequency control input signal 1
RESN	12	reset output (active-LOW, Fig.4)
V <sub>SSD3</sub>	13	digital ground 3 (0 V)
LLC2A	14	line-locked clock output signal 2A (2 times $f_{LFCO}$ )
CREF	15	clock reference output, qualifier signal (2 times $f_{LFCO}$ )
LFCOSEL	16	LFCO source select (LOW = LFCO selected)*
V <sub>DDD2</sub>	17	digital supply voltage 2 (+5 V)
V <sub>SSD4</sub>	18	digital ground 4 (0 V)
LFCO2	19	line-locked frequency control input signal 2*
LLC2B	20	line-locked clock output signal 2B (2 times $f_{LFCO}$ )

## PIN CONFIGURATION

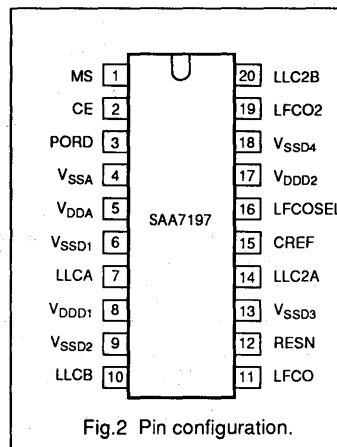

## LIMITING VALUES

In accordance with the Absolute Maximum Rating System (IEC 134); ground pins as well as supply pins together connected.

SYMBOL	PARAMETER	MIN.	MAX.	UNIT
V <sub>DDA</sub>	analog supply voltage (pin 5)	-0.5	7.0	V
V <sub>DDD</sub>	digital supply voltage (pins 8 and 17)	-0.5	7.0	V
V <sub>diff GND</sub>	difference voltage V <sub>DDA</sub> - V <sub>DDD</sub>	-	±100	mV
V <sub>O</sub>	output voltage (I <sub>OM</sub> = 20 mA)	-0.5	V <sub>DDD</sub>	V
P <sub>tot</sub>	total power dissipation (DIL20)	0	1.1	W
T <sub>stg</sub>	storage temperature range	-65	150	°C
T <sub>amb</sub>	operating ambient temperature range	0	70	°C
V <sub>ESD</sub>	electrostatic handling** for all pins	-	tbf	V

\* MS and LFCO2 functions are not tested. LFCO2 is a multiple of horizontal frequency.

\*\* Inputs and outputs are protected against electrostatic discharge in normal handling. However, to be totally safe, it is recommended to take normal handling precautions appropriate to "Handling MOS devices".

# Clock signal generator circuit for Destop Video systems (SCGC)

SAA7197

**CHARACTERISTICS**
 $V_{DDA} = 4.5$  to  $5.5$  V;  $V_{DDD} = 4.5$  to  $5.5$  V;  $f_{LFCO} = 5.5$  to  $8.0$  MHz and  $T_{amb} = 0$  to  $70$  °C unless otherwise specified.

SYMBOL	PARAMETER	CONDITIONS	MIN.	TYP.	MAX.	UNIT
$V_{DDA}$	analog supply voltage (pin 5)		4.5	5.0	5.5	V
$V_{DDD}$	digital supply voltage (pins 8 and 17)		4.5	5.0	5.5	V
$I_{DDA}$	analog supply current (pin 5)		5	-	9	mA
$I_{DDD}$	digital supply current ( $I_8 + I_{17}$ )	note 1	10	-	60	mA
$V_{reset}$	power-on reset threshold voltage	Fig.4	-	3.5	-	V
<b>Input LFCO (pin 11)</b>						
$V_{11}$	DC input voltage		0	-	$V_{DDA}$	V
$V_i$	input signal (peak-to-peak value)		1	-	$V_{DDA}$	V
$f_{LFCO}$	input frequency range		5.5	-	8.0	MHz
$C_{11}$	input capacitance		-	-	10	pF
<b>Inputs MS, CE, LFCOSEL and LFCO2 (pins 1, 2, 16 and 19)</b>						
$V_{IL}$	input voltage LOW		0	-	0.8	V
$V_{IH}$	input voltage HIGH		2.0	-	$V_{DDD}$	V
$f_{LFCO2}$	input frequency range for LFCO2	note 3	5.5	-	8.0	MHz
$I_{LI}$	input leakage current		-	-	10	$\mu$ A
$C_1$	input capacitance		-	-	5	pF
<b>Output RESN (pin 12)</b>						
$V_{OL}$	output voltage LOW		0	-	0.4	V
$V_{OH}$	output voltage HIGH		2.4	-	$V_{DDD}$	V
$t_d$	RESN delay time	$C_3 = 0.1 \mu\text{F}$ ; Fig.4	20	-	200	ms
<b>Output CREF (pin 15)</b>						
$V_{OL}$	output voltage LOW		0	-	0.6	V
$V_{OH}$	output voltage HIGH		2.4	-	$V_{DDD}$	V
$f_{CREF}$	output frequency CREF	Fig.3	-	$2 f_{LFCO(2)}$		MHz
$C_L$	output load capacitance		15	-	40	pF
$t_{SU}$	set-up time	Fig.3; note 1	12	-	-	ns
$t_{HD}$	hold time	Fig.3; note 1	4	-	-	ns
<b>Output signals LLCA, LLCB, LLC2A and LLC2B (pins 7, 10, 14, and 20); note 3</b>						
$V_{OL}$	output voltage LOW	$I_{OL} = 2$ mA	0	-	0.6	V
$V_{OH}$	output voltage HIGH	$I_{OH} = -0.5$ mA	2.6	-	$V_{DDD}$	V
		CE = HIGH (pin 2)	2.6	-	$V_{DDD}$	V
$t_{comp}$	composite rise time	Fig.3; notes 1 and 2	-	-	8	ns

# Clock signal generator circuit for Destop Video systems (SCGC)

SAA7197

SYMBOL	PARAMETER	CONDITIONS	MIN.	TYP.	MAX.	UNIT
$f_{LL}$	output frequency LLCA	Fig.3	-	$4 f_{LFCO(2)}$		MHz
	output frequency LLCB		-	$4 f_{LFCO(2)}$		MHz
	output frequency LLC2A		-	$2 f_{LFCO(2)}$		MHz
	output frequency LLC2B		-	$2 f_{LFCO(2)}$		MHz
$t_r, t_f$	rise and fall times	Fig.3;	-	-	5	ns
$t_{LL}$	duty factor LLCA, LLCB, LLC2A and LLC2B (mean values)	note 1; Fig.3; at 1.5 V level	40	50	60	ns

**Notes to the characteristics**

- $f_{LFCO} = 7.0$  MHz and output load 40 pF (Fig.3)
- $t_{comp}$  is the rise time from LOW of all clocks to HIGH of all clocks (Fig.3) including rise time, skew and jitter components. Measurements taken between 0.6 V and 2.6 V. Skew between two LLx clocks will not deviate more than  $\pm 2$  ns if output loads are matched within 20 %.
- LFCO2 functions not tested.

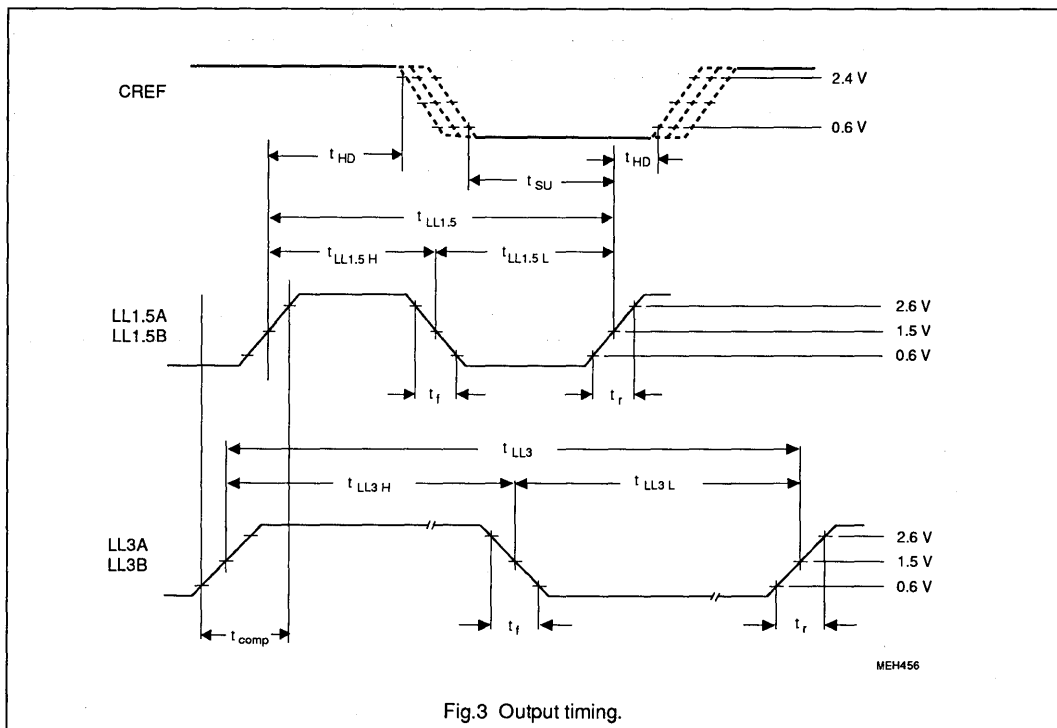

Fig.3 Output timing.

# Clock signal generator circuit for Destop Video systems (SCGC)

SAA7197

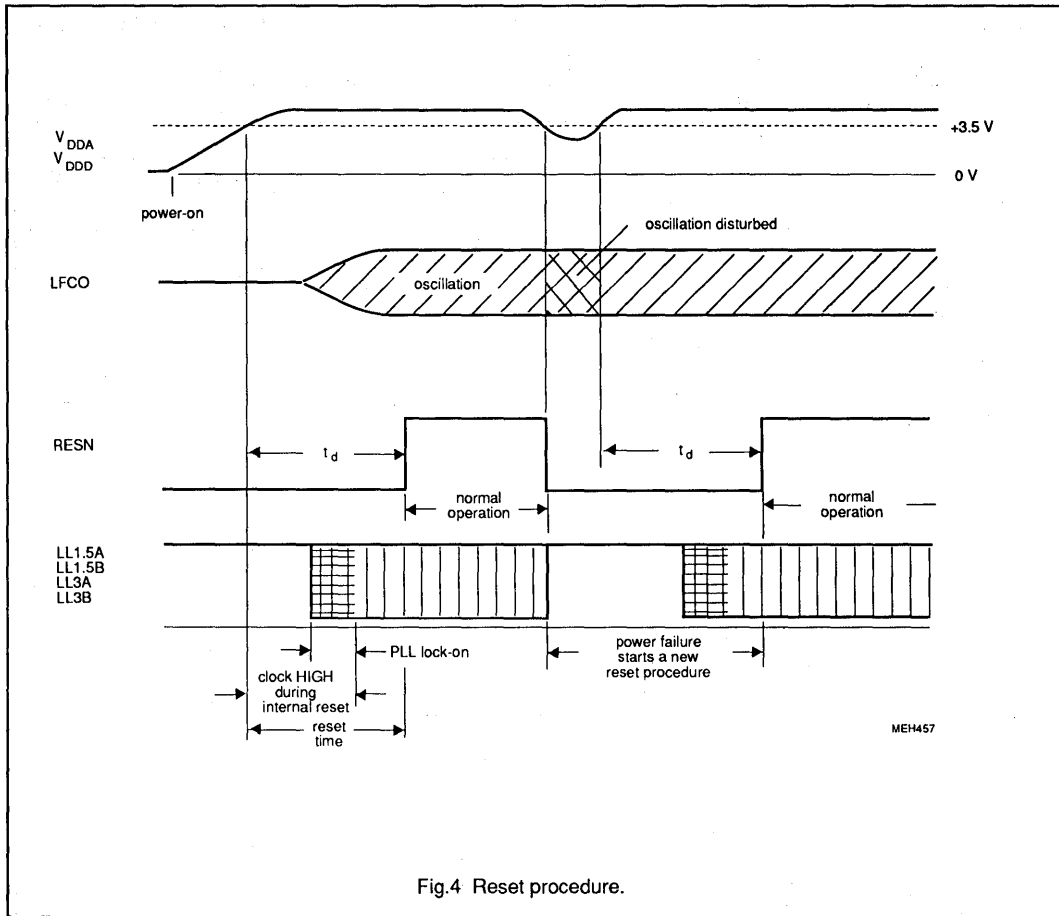

Fig.4 Reset procedure.



# Digital video encoder, GENLOCK-capable

# SAA7199B

## 1. FEATURES

- Monolithic integrated CMOS video encoder circuit
- Standard MPU (12 lines) and I<sup>2</sup>C-bus interfaces for controls
- Three 8-bit signal inputs PD(7-0) for RGB respectively YUV or indexed colour signals (Tables 10 to 17)
- Square pixel and CCIR input data rates
- Band-limited composite sync pulses
- Three 256X8 colour look-up tables (CLUTs) e. g. for gamma-correction
- External subcarrier from a digital decoder (SAA7151B or SAA7191B)
- Multi-purpose key for real-time format switching
- Autonomous internal blanking
- Optional GENLOCK operation with adjustable horizontal sync timing and adjustable subcarrier phase
- Stable GENLOCK operation in VCR standard playback mode
- Optional still video capture extension
- Three suitable video 9-bit digital-to-analog converters
- Composite analog output signals CVBS, Y and C for PAL/NTSC
- "Line 21" data insertion possible

## 2. GENERAL DESCRIPTION

The SAA7199B encodes digital base-band colour/video data into analog Y, C and CVBS signals (S-Video included). Pixel clock and data are line-locked to the horizontal scanning frequency of the video signal. The circuit can be used in a square pixel or in a consumer TV application. Flexibility is provided by programming facilities via MPU-bus (parallel) or I<sup>2</sup>C-bus (serial).

## 3. QUICK REFERENCE DATA

SYMBOL	PARAMETER	MIN.	TYP.	MAX.	UNIT
V <sub>DDD</sub>	digital supply voltage range (pins 2, 21 and 41)	4.5	5.0	5.5	V
V <sub>DDA</sub>	analog supply voltage range (pins 64, 66, 70 and 72)	4.75	5.0	5.25	V
I <sub>P</sub>	total supply current	-	-	200	mA
V <sub>I</sub>	input signal levels	TTL-compatible			
V <sub>o</sub>	analog output signals Y, C and CVBS without load (peak-to-peak value)	-	2	-	V
R <sub>L</sub>	output load resistance	90	-	-	Ω
ILE	LF integral linearity error in output signal (9-bit DAC)	-	-	±1	LSB
DLE	LF differential linearity error in output signal (9-bit DAC)	-	-	±0.5	LSB
T <sub>amb</sub>	operating ambient temperature range	0	-	70	°C

## 4. ORDERING INFORMATION

EXTENDED TYPE NUMBER	PACKAGE			
	PINS	PIN POSITION	MATERIAL	CODE
SAA7199B	84	PLCC	plastic	SOT189CG

Digital video encoder,  
GENLOCK-capable

SAA7199B

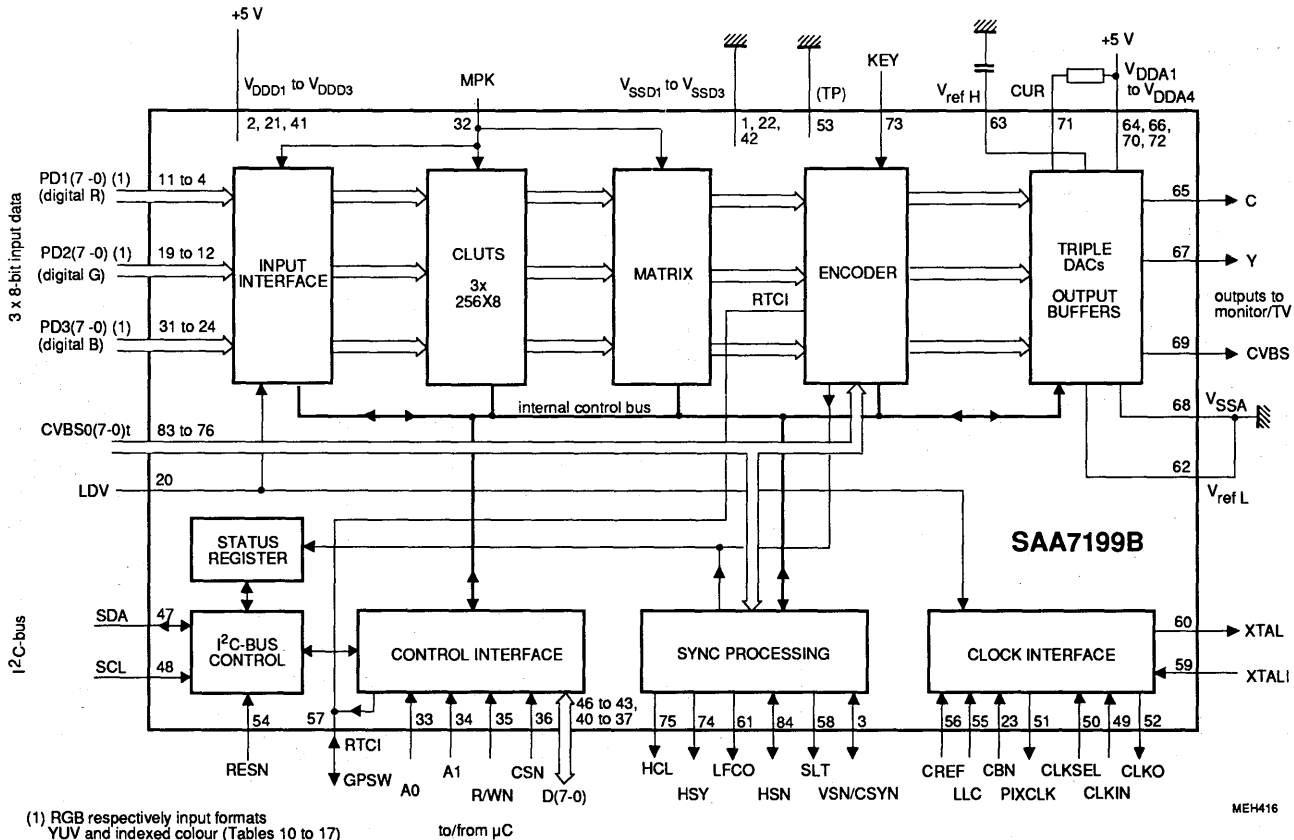

Fig. 1 Block diagram (application details Fig.4).

# Digital video encoder, GENLOCK-capable

## SAA7199B

### PINNING

SYMBOL	PIN	DESCRIPTION
V <sub>SSD1</sub>	1	digital ground 1 (0 V)
V <sub>DDD1</sub>	2	+5 V digital supply 1
VSN	3	vertical sync output (3-state), conditionally composite sync output; active LOW or active HIGH
PD1(0)	4	data 1 input: digital signal R (red) respectively V signal (formats in Table 6)
PD1(1)	5	
PD1(2)	6	
PD1(3)	7	
PD1(4)	8	
PD1(5)	9	
PD1(6)	10	
PD1(7)	11	
PD2(0)	12	data 2 input: digital signal G (green) respectively Y signal or indexed colour data (formats in Table 6)
PD2(1)	13	
PD2(2)	14	
PD2(3)	15	
PD2(4)	16	
PD2(5)	17	
PD2(6)	18	
PD2(7)	19	
LDV	20	load data clock input signal to input interface (samples PDn(7-0), CBN, MPK, KEY and RTCI)
V <sub>DDD2</sub>	21	+5 digital supply 2
V <sub>SSD2</sub>	22	digital ground 2 (0 V)
CBN	23	composite blanking input; active LOW
PD3(0)	24	data 3 input: digital signal B (blue) respectively U signal (formats in Table 6)
PD3(1)	25	
PD3(2)	26	
PD3(3)	27	
PD3(4)	28	
PD3(5)	29	
PD3(6)	30	
PD3(7)	31	
MPK	32	multi-purpose key; active HIGH
A0	33	subaddress bit A0 for microcomputer access (Table 3)
A1	34	subaddress bit A1 for microcomputer access (Table 3)

**Digital video encoder,  
GENLOCK-capable**
**SAA7199B**

SYMBOL	PIN	DESCRIPTION
R/WN	35	read/ write not input signal from microcontroller
CSN	36	chip select input for parallel interface; active LOW
D0	37	bidirectional port from/to microcontroller (bits D3 to D0)
D1	38	
D2	39	
D3	40	
V <sub>DD3</sub>	41	+5 V digital supply 3
V <sub>SS3</sub>	42	digital ground 3
D4	43	bidirectional port from/to microcontroller (bits D7 to D4)
D5	44	
D6	45	
D7	46	
SDA	47	I <sup>2</sup> C-bus data line
SCL	48	I <sup>2</sup> C-bus clock line
CLKIN	49	external clock signal input (maximum 60 MHz)
CLKSEL	50	clock source select input
PIXCLK	51	CLKO/2 or conditionally CLKO output signal
CLKO	52	selected clock output signal (LLC or CLKIN)
TP	53	connect to ground (test pin)
RESN	54	reset input; active LOW
LLC	55	line-locked clock input signal from external CGC
CREF	56	clock qualifier of external CGC
GPSW / RTCI	57	general purpose switch output (set via I <sup>2</sup> C-bus or MPU-bus); real-time control input, defined by I <sup>2</sup> C or MPU programming
SLT	58	GENLOCK flag (3-state): HIGH = sync lost in GENLOCK mode; LOW = otherwise
XTALI	59	crystal oscillator input (26.8 or 24.576 MHz)
XTAL	60	crystal oscillator output
LFCO	61	line frequency control output signal for external CGC
V <sub>refL</sub>	62	reference LOW voltage of DACs (resistor chains)
V <sub>refH</sub>	63	reference HIGH voltage of DACs (resistor chains)
V <sub>DDA4</sub>	64	+5 V analog supply 4 for resistor chains of the DACs
C	65	chrominance analog output signal C
V <sub>DDA1</sub>	66	+5 V analog supply 1 for output buffer amplifier of DAC1
Y	67	luminance analog output signal Y
V <sub>SSA</sub>	68	analog ground (0 V)

# Digital video encoder, GENLOCK-capable

## SAA7199B

SYMBOL	PIN	DESCRIPTION
CVBS	69	CVBS analog output signal
V <sub>DDA2</sub>	70	+5 V analog supply 2 for output buffer amplifier of DAC2
CUR	71	current input for analog output buffers
V <sub>DDA3</sub>	72	+5 V analog supply 3 for output buffer amplifier of DAC3
KEY	73	key signal to insert CVBS input signal into encoded CVBS output signal; active HIGH
HSY	74	horizontal sync indicator output signal; active HIGH (3-state output to ADC)
HCL	75	horizontal clamping output; active HIGH (3-state output)
CVBS0	76	digital CVBS input signal
CVBS1	77	
CVBS2	78	
CVBS3	79	
CVBS4	80	
CVBS5	81	
CVBS6	82	
CVBS7	83	
HSN	84	horizontal sync output; active LOW or active HIGH for 60/66/72 x PIXCLK at 12.27/13.5/14.75 MHz (3-state output)

### FUNCTIONAL DESCRIPTION

The SAA7199B is a digital video encoder that translates digital RGB, YUV or 8-bit indexed colour signals into the analog PAL/NTSC output signals Y (luminance), C (4.43/3.58 MHz chrominance) and CVBS (composite signal including sync).

Four different modes are selectable (Table 9):

- stand-alone mode (horizontal and vertical timings are generated)
- slaver mode (stand-alone unit that accepts external horizontal and vertical timing), and optional real-time information for subcarrier/clock from a digital colour decoder
- GENLOCK mode (GENLOCK capabilities are achieved in conjunction with determined ICs).
- test mode (only clock signal is required)

The input data rate (pixel sequence) has

an integer relationship to the number of horizontal clock cycles (Table 1). A sufficient stable external clock signal ensures correct encoding. The generated clock frequency in the GENLOCK mode may deviate by  $\pm 7\%$  depending on the reference signal which is corresponding to its input sync signal. The clock will be nominal in the GENLOCK mode when the reference signal is absent (nominal with crystal oscillator accuracy for TV time constants, and nominal  $\pm 1.4\%$  for VCR time constants).

The on-chip colour conversion matrix provides CCIR 601 code-compatible transcoding of RGB to YUV data.

RGB data out of bounds, with respect to CCIR 601 specification, can be clipped to prevent over-loading of the colour modulator. RGB data input can be either in linear colour space or in gamma-corrected colour space. YUV data must be gamma-corrected according to CCIR 601. This circuit operates primarily in a 24-bit colour space (3 x 8-bit) but can also accommodate different data formats (4:1:1, 4:2:2 and 4:4:4) as well as 8-bit indexed pseudo-colour space operations (FMT-bits in Table 6).

RGB CLUTs on chip provide gamma-correction and/or other CLUT functions. They consist of programmable tables to be loaded

**Table 1** Pixel relationships

ACTIVE PIXELS PER LINE	FIELD RATE	MULTIPLES OF LINE FREQUENCY	PIXCLK OUTPUT SIGNAL (MHz)	XTAL (MHz)
640 (square)	60 Hz	780	12.272727	26.8
720	60 Hz	858	13.5	24.576
768 (square)	50 Hz	944	14.75	26.8
720	50 Hz	864	13.5	24.576

# Digital video encoder, GENLOCK-capable

## SAA7199B

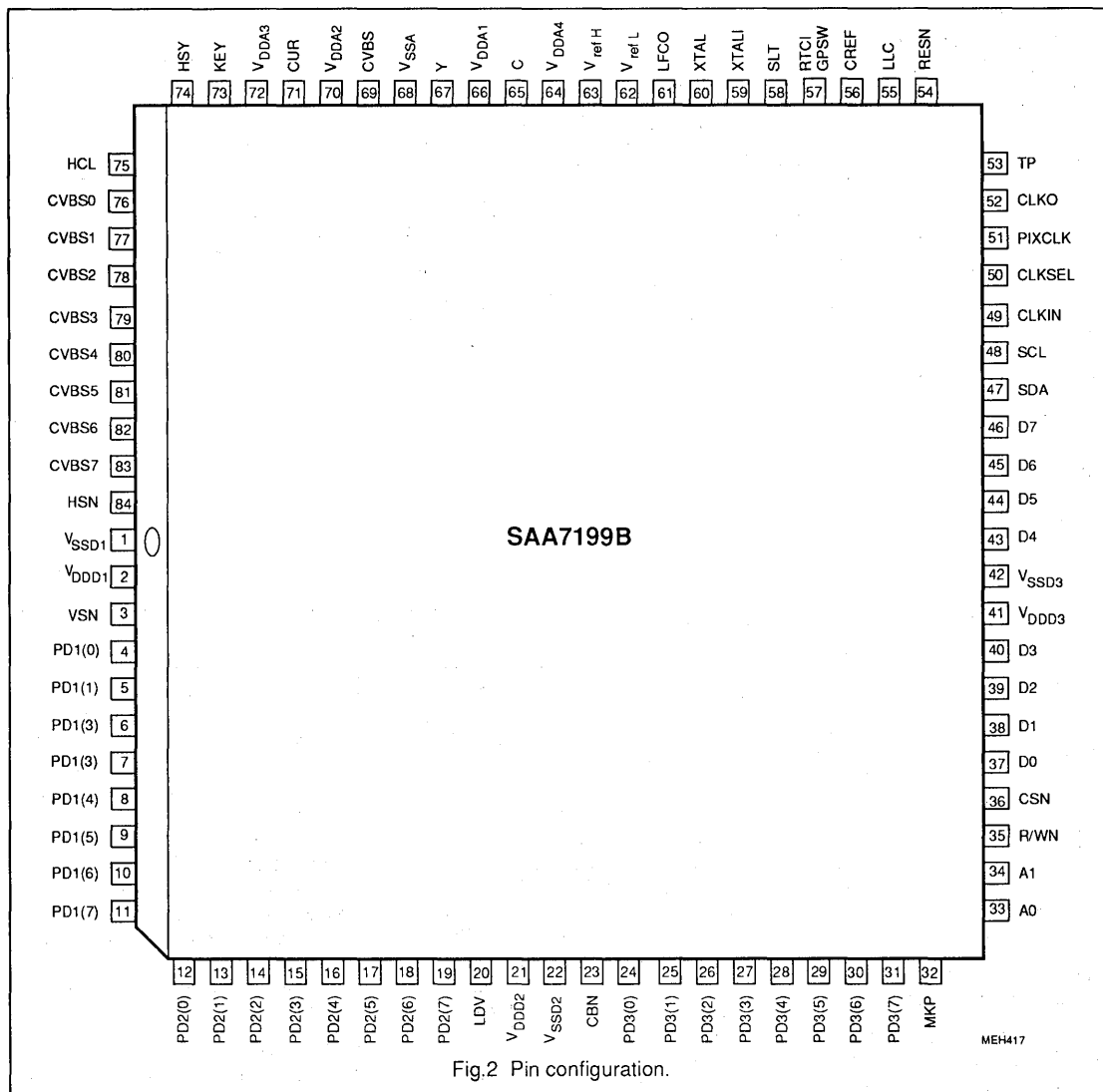

Fig.2 Pin configuration.

independently, and they generate 24-bit gamma-corrected output signals from 24-bit data of one of the input formats or from 8-bit indexed pseudo-colour data.

Required modulation is performed. The digital YUV data is encoded according to standards RS-170A (composite NTSC) and CCIR 624-4 (composite PAL-B/G). S-Video

output signal is available (Y/C) as well as some sub-standard output signals (STD-bits in Table 6).

A 7.5 IRE set-up level is automatically selected in the 60 Hz mode – there is none in 50 Hz mode.

The analog signal outputs can drive directly into terminated 75 Ω coaxial lines, a passive external filter is recommended (Figures 3 and 13).

Analog post-filtering is required (LP in Fig.3).

GENLOCK to an external reference signal is achieved by addition of a video ADC and a clock generator combination. Thus, the system is enabled to lock on a stable video source or to a stable VCR source (normal playback). The SAA7199B, the ADC and the clock generator

Digital video encoder,  
GENLOCK-capable

SA A7199B

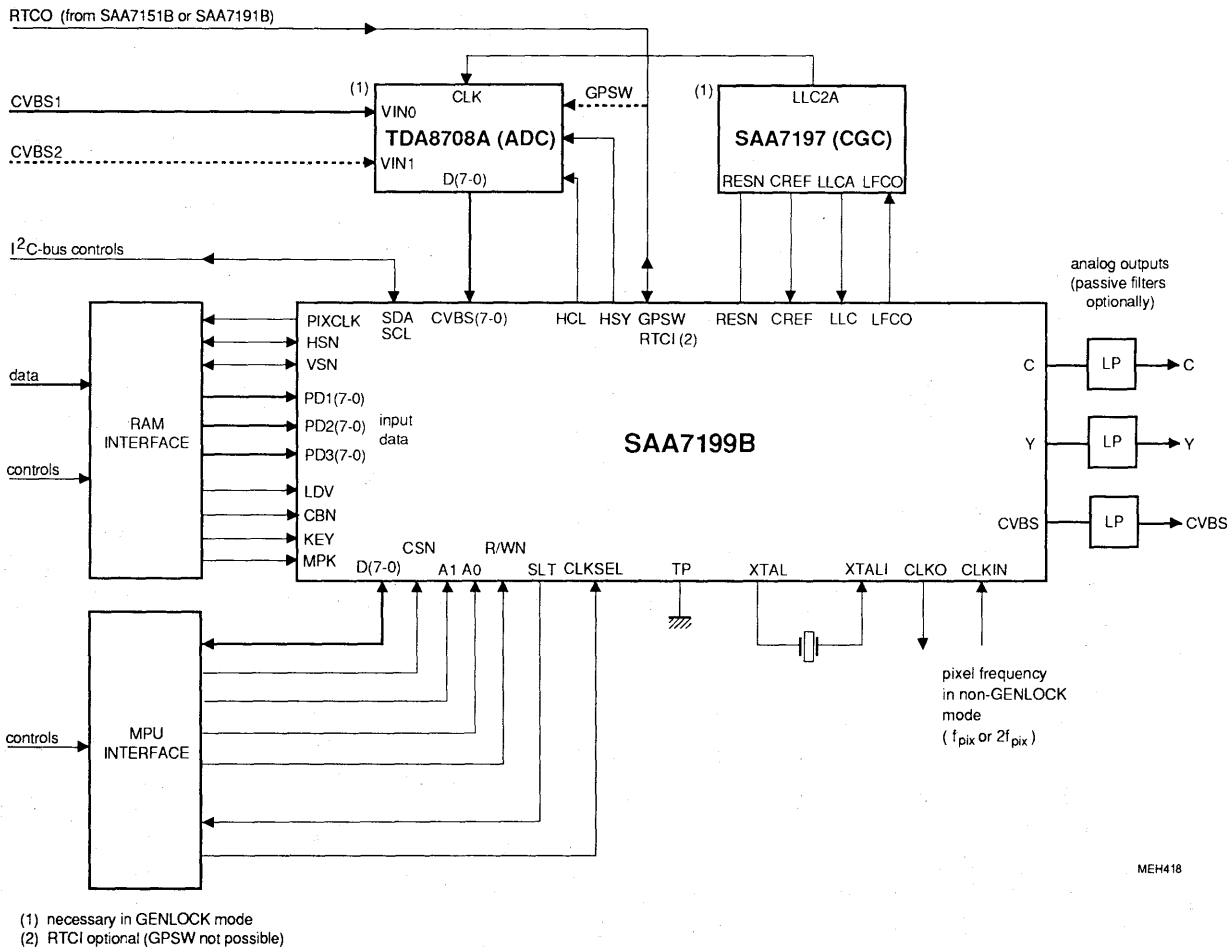

Fig.3 System configuration.

## Digital video encoder, GENLOCK-capable

SAA7199B

combination (Fig.3) form a control loop achieving a highly stable line-locked clock. The clock has to be generated by a crystal oscillator without this possibility. The GENLOCK mode is not available in a single device set-up.

### Control interface

The SAA7199B supports a standard parallel MPU interface as well as the serial I<sup>2</sup>C-bus interface. The MPU has a direct access to internal control registers and colour tables. Update is possible at any time, excluding coincident internal reading and external writing of the same cell (the current pixel value could be destroyed).

The two interfaces of Table 2 are selected automatically. However, the I<sup>2</sup>C control is inactive when the MPU interface is selected by CSN = LOW. No simultaneous access must occur. I<sup>2</sup>C-bus and MPU control complement each other and have access to common registers controlled via a common internal bus. The programmer can use virtually identical programs.

The internal memory space is divided into the look-up table and the control table, each with its own 8-bit address register is used as a pointer for specific location. This address register is provided with auto-incrementation and can be written by only one addressing.

The look-up table contains three banks of 256 bytes. Therefore, each read or write cycle must access to all three banks in a determined order. The support logic is part of the control interface.

### Timing (Fig.3).

The reference to generate internal clocks from LLC in GENLOCK operation with SAA7197 is CREF (CREF = LLC/2). In this case input CLKSEL is HIGH and the SRC-bit is 1.

In non-GENLOCK operation the signal from CLKIN is used and LDV is clock reference (input CLKSEL = 0; SCR-bit = CPR-bit = 0).

**Table 2** Access to the control interface

SYMBOL	DESCRIPTION
SDA (I <sup>2</sup> C-bus)	serial data line (bi-directional)
SCL	clock line
A1, A0 (MPU-bus)	address inputs
R/WN	read/write control
CSN	chip select; I <sup>2</sup> C-bus disabled (at LOW)
GPSW	general purpose switch output (bit of control register)
RESN	reset signal (active-LOW)

**Table 3** Address assignment

ADDRESS INPUTS		I <sup>2</sup> C-BUS SUBADDRESS	SELECTION
A1	A0		
0	0	00	ADR-CLUT (address register of look-up tables)
0	1	01	DATA-CLUT
1	0	02	ADR-CTRL (index register of control table)
1	1	03	DATA-CTRL

Pins LLC and CLKIN are tied together when no switching between LLC and CLKIN is applied. In Fig.3 it is assumed that LLC and CLKIN are double the pixel clock frequency of CREF respectively LDV. CREF must be at the same frequency (or constant HIGH or LOW) when LLC is at pixel clock frequency. CPR-bit = 1 if CLKIN is at pixel clock frequency. Buffered CLKO signal is always delayed. LLC or CLKIN signals are according to CLKSEL.

### Mapping

Mapping of external control signals onto internal bus. The method is simple. The MPU-bus contains the signals of Table 4 (names in chip-internal nomenclature).

### Bit allocation

The Bit Allocation Map (BAM) shows the individual control signals, used to control the different operational modes of the circuit. The I<sup>2</sup>C-bus is normally used for control. The SAA7199B additionally has a MPU-bus interface for direct microprocessor connection. The

following BAM resembles the I<sup>2</sup>C-bus type but can be also used for the parallel bus. The control registers of Table 5 are indexed from 00 to 0F (hex). Auto-incrementation is applied.

### Digital-to-analog converters

The converters use a combination of resistor chains with low-impedance output buffers. The bottom output voltage is 200 mV to reduce integral non-linearity errors. The analog signal, without load on output pin, is between 0.2 and 2.2 V. Fig.15 shows the application for 1.23 V/75 Ω outputs, using the serial 25 Ω + 22 Ω resistors.

Each digital-to-analog converter has its own supply pin for purpose of decoupling. V<sub>DDA4</sub> is the supply voltage for the resistor chains of the three DACs. The accuracy of this supply voltage influences directly the output amplitudes. The current CUR into pin 71 is 0.3 mA (V<sub>DDA4</sub> = 5 V, R<sub>64-71</sub> = 20 kΩ); a larger current improves the bandwidth but increases the integral non-linearity.



# Digital video encoder, GENLOCK-capable

## SAA7199B

**Table 4** Signals on the internal bus

SYMBOL	DESCRIPTION	
R-WN C-TN D-AN	Select read/write (read = 1; write = 0) Control table/look-up table (control table = 1; look-up table = 0) Select data/address (data = 1; address = 0)	
DI/DO(0-7) EN	Data bus on port inputs/outputs D7 to D0 Enable from control interface to synchronize data transfer	
INTERNAL PARALLEL BUS	PARALLEL INTERFACE	I <sup>2</sup> C-BUS INTERFACE
R-WN C-TN A-TN	R/WN (pin 35) A1 (pin 34) A0 (pin 33)	LSB of slave address byte (read = HIGH; write = LOW) X ) X ) 4 subaddresses after decoding
DI/DO(0-7) EN	D7 to D0 CSN and R/WN	Data bits D7 to D0 for each subaddress Enable by every 9th clock of sample of SCL (control of serial-to-parallel conversion)

**Table 5** Bit allocation map (I<sup>2</sup>C-bus access in Table 8)

INDEX BINARY	HEX	DATA BYTE								DF**
		D7	D6	D5	D4	D3	D2	D1	D0	
Input processing										
0000 0000	00	VTBY	FMT2	FMT1	FMT0	SCBW	CCIR	MOD1	MOD0	5C
0000 0001	01	TRER7	TRER6	TRER5	TRER4	TRER3	TRER2	TRER1	TRER0	XX
0000 0010	02	TREG7	TREG6	TREG5	TREG4	TREG3	TREG2	TREG1	TREG0	XX
0000 0011	03	TREB7	TREB6	TREB5	TREB4	TREB3	TREB2	TREB1	TREB0	XX
Sync processing										
0000 0100	04	SYSEL1	SYSEL0	SCEN	VTRC	NINT	HPLL	HLCK*	OEF*	10
0000 0101	05	0	0	GDC5	GDC4	GDC3	GDC2	GDC1	GDC0	21
0000 0110	06	IDEL7	IDEL6	IDEL5	IDEL4	IDEL3	IDEL2	IDEL1	IDEL0	52
0000 0111	07	0	0	PSO5	PSO4	PSO3	PSO2	PSO1	PSO0	32
Control, clock and output formatter										
0000 1000	08	DD	KEYE	SRC	CPR	COKI	IM	GPSW	SRSN	64
0000 1001	09	0	BAME	MPKC1	MPKC0	IEPI	RTSC	RTIN	RTCE	02
0000 1010+	0A+	0	0	0	0	0	0	0	0	00
0000 1011+	0B+	0	0	0	0	0	0	0	0	00
Encoder control										
0000 1100	0C	CHPS7	CHPS6	CHPS5	CHPS4	CHPS3	CHPS2	CHPS1	CHPS0	XX**
0000 1101	0D	FSCO7	FSCO6	FSCO5	FSCO4	FSCO3	FSCO2	FSCO1	FSCO0	00
0000 1110	0E	0	0	0	CLK*	STD3	STD2	STD1	STD0	0C
0000 1111+	0F+	0	0	0	0	0	0	0	0	

\*) read only bits    +) reserved    \*\*) adjust as required.

\*\*\*) DF is the default value for a typical programming example: GENLOCK mode for a VCR; non-gamma-corrected RGB data (realtime keying is possible). SLT will be set if there is no horizontal lock. NTSC-M standard with normal colour bandwidth and 12.2727 MHz pixel rate. CSYN signal will be provided, coming 8 pixel clocks earlier, to compensate pipeline delay in the previous RAM interface. The encoded CVBS is 12 clocks earlier than the CVBS reference on the input of the previous ADC. The CLUTs are bypassed at MPK = HIGH in real-time.

# Digital video encoder, GENLOCK-capable

## SAA7199B

**Table 6** Function of register bits of Table 5

Index "00" VTBY	Video look-up table by-pass:	0 = not bypassed; 1 = bypassed (OR connectable with MPK)																																				
FMT2 to FMT0	Input formats:																																					
	<table border="1"> <thead> <tr> <th>FMT2</th> <th>FMT1</th> <th>FMT0</th> <th>format</th> </tr> </thead> <tbody> <tr> <td>0</td> <td>0</td> <td>0</td> <td>YUV 4:1:1 format; DMSD2 compatible</td> </tr> <tr> <td>0</td> <td>0</td> <td>1</td> <td>YUV 4:1:1 format; customized</td> </tr> <tr> <td>0</td> <td>1</td> <td>0</td> <td>YUV 4:2:2 format; DMSD2 compatible</td> </tr> <tr> <td>0</td> <td>1</td> <td>1</td> <td>YUV 4:2:2 format; customized</td> </tr> <tr> <td>1</td> <td>0</td> <td>0</td> <td>YUV 4:4:4 format</td> </tr> <tr> <td>1</td> <td>0</td> <td>1</td> <td>RGB 4:4:4 format</td> </tr> <tr> <td>1</td> <td>1</td> <td>0</td> <td>reserved</td> </tr> <tr> <td>1</td> <td>1</td> <td>1</td> <td>8-bit indexed colour</td> </tr> </tbody> </table>	FMT2	FMT1	FMT0	format	0	0	0	YUV 4:1:1 format; DMSD2 compatible	0	0	1	YUV 4:1:1 format; customized	0	1	0	YUV 4:2:2 format; DMSD2 compatible	0	1	1	YUV 4:2:2 format; customized	1	0	0	YUV 4:4:4 format	1	0	1	RGB 4:4:4 format	1	1	0	reserved	1	1	1	8-bit indexed colour	
FMT2	FMT1	FMT0	format																																			
0	0	0	YUV 4:1:1 format; DMSD2 compatible																																			
0	0	1	YUV 4:1:1 format; customized																																			
0	1	0	YUV 4:2:2 format; DMSD2 compatible																																			
0	1	1	YUV 4:2:2 format; customized																																			
1	0	0	YUV 4:4:4 format																																			
1	0	1	RGB 4:4:4 format																																			
1	1	0	reserved																																			
1	1	1	8-bit indexed colour																																			
SCBW CCIR	Chrominance bandwidth:	0 = enhanced; 1 = standard																																				
	Select level:	0 = DMSD2 levels; 1 = CCIR levels																																				
MOD1 to MOD0	Select mode:																																					
	<table border="1"> <thead> <tr> <th>MOD1</th> <th>MOD0</th> <th>mode</th> </tr> </thead> <tbody> <tr> <td>0</td> <td>0</td> <td>GENLOCK mode</td> </tr> <tr> <td>0</td> <td>1</td> <td>stand-alone mode</td> </tr> <tr> <td>1</td> <td>0</td> <td>slave mode</td> </tr> <tr> <td>1</td> <td>1</td> <td>test mode</td> </tr> </tbody> </table>	MOD1	MOD0	mode	0	0	GENLOCK mode	0	1	stand-alone mode	1	0	slave mode	1	1	test mode																						
MOD1	MOD0	mode																																				
0	0	GENLOCK mode																																				
0	1	stand-alone mode																																				
1	0	slave mode																																				
1	1	test mode																																				
Index "01" TRER7 to TRER0	Test register Red (read/write via MPU-bus; write only via I <sup>2</sup> C-bus)																																					
Index "02" TREG7 to TREG0	Test register Green (read/write via MPU-bus; write only via I <sup>2</sup> C-bus)																																					
Index "03" TREB7 to TREB0	Test register Blue (read/write via MPU-bus; write only via I <sup>2</sup> C-bus)																																					
Index "04" SYSEL1 to SYSEL0	Sync select:																																					
	<table border="1"> <thead> <tr> <th>SYSEL1</th> <th>SYSEL0</th> <th>synchronized from</th> </tr> </thead> <tbody> <tr> <td>0</td> <td>0</td> <td>CSYN (active LOW; pin 3)</td> </tr> <tr> <td>0</td> <td>1</td> <td>HSN and VSN (active LOW; pins 84 and 3)</td> </tr> <tr> <td>1</td> <td>0</td> <td>CSYN (active HIGH; pin 3)</td> </tr> <tr> <td>1</td> <td>1</td> <td>HSN and VSN (active HIGH; pins 84 and 3)</td> </tr> </tbody> </table>	SYSEL1	SYSEL0	synchronized from	0	0	CSYN (active LOW; pin 3)	0	1	HSN and VSN (active LOW; pins 84 and 3)	1	0	CSYN (active HIGH; pin 3)	1	1	HSN and VSN (active HIGH; pins 84 and 3)																						
SYSEL1	SYSEL0	synchronized from																																				
0	0	CSYN (active LOW; pin 3)																																				
0	1	HSN and VSN (active LOW; pins 84 and 3)																																				
1	0	CSYN (active HIGH; pin 3)																																				
1	1	HSN and VSN (active HIGH; pins 84 and 3)																																				
SCEN	Sync/clamping (HSY/HCL) enable:	0 = disabled (set to HIGH); 1 = enabled																																				
VTRC	Select TV/VTR mode:	0 = 0 TV mode (slow); 1 = VTR mode (fast)																																				
NINT	Select interlace of encoded signal:	0 = interlaced (262.5/262.5 or 312.5/312.5) 1 = non-interlaced (262/262 or 312/312 in modes 1 and 3 only)																																				

# Digital video encoder, GENLOCK-capable

## SAA7199B

HPLL	Select horizontal lock:           0 = lock enabled; 1 = lock disabled (crystal reference)
OEF	Status bit field organization (to be read):           0 = even field; 1 = odd field
HLCK	Status bit sync indication (to be read):           0 = locked to external sync 1 = external sync lost
Index "05" GDC5 to GDC0	GENLOCK delay compensation, note 1:   data 00 to 3F equals timing of CVBS output signal is $(46 - GDC)$ pixel clocks = $t_{ofs}$ earlier with respect to reference point $t_{REF1}$ . ( $t_{REF1}$ corresponds to the falling edge of the horizontal sync pulse of CVBS input signal; $t_{ofs}$ is designated for propagation delay of extern GENLOCK source, Fig.10).
Index "06" IDEL7 to IDEL0	Increment delay: update of line-locked clock frequency (Table 5, data "43" hex recommended)
Index "07" PSO7 to PSO0	Phase sync in output signal, note 1:   data 00 to 3F equals to active slope of HSN, VSN/CSYN is $(58 - PSO)$ pixel clocks = $t_{Rint}$ earlier with respect to reference point $t_{REF2}$ . ( $t_{REF2}$ corresponds to $PSO = 58$ ; $t_{Rint}$ is designated for pipeline delay of the feeding RAM interface, Fig.10).
Index "08" DD	Digital video encoder disable:           0 = enabled; 1 = disabled
KEYE	Keying enable:           0 = disabled; 1 = enabled (logically AND-connected with KEY)
SRC	Clock source:           0 = external system clock; 1 = DTV2 system clock
CPR	Clock phase reference:           0 = LDV is (pin 20); 1 = LDV is not
COKI	Colour-killer:           0 = colour on; 1 = colour off (subcarrier is switched off)
IM	Interrupt mask:           1 = interrupt not masked at sync lost (pin 58) 0 = interrupt masked at sync lost (pin 58)
GPSW	General purpose switch at bit RTIN = 1:           0 = pin 57 LOW; 1 = pin 57 HIGH
SRSN	Software reset:           0 = no reset; 1 = reset (see reset procedure)
Index "09" BAME	Burst amplitude indication:   0..= burst amplitude measurement is overridden; colour lock always assumed 1 = burst amplitude is used to control the CLCK status bit, recommended for reference signal without subcarrier burst (pure black and white) in order to avoid PLL hunting.

# Digital video encoder, GENLOCK-capable

## SAA7199B

MPKC1 to MPKC0	<p>Multi-purpose key control: At MKP = LOW (pin 32) are all functions as given by software programming; MKP = HIGH sets in real-time with respect to PDn(7-0).</p> <table border="1" data-bbox="379 354 1229 673"> <thead> <tr> <th colspan="2">Set by bits</th> <th colspan="4">in function blocks</th> </tr> <tr> <th>MPKC1</th> <th>MPKC0</th> <th>input formatter</th> <th>CLUTs</th> <th>matrix</th> <th>level matching</th> </tr> </thead> <tbody> <tr> <td>0</td> <td>0</td> <td>control via CCIR bit and FMT bits</td> <td>bypass</td> <td>control via FMT bits</td> <td>control via CCIR bit</td> </tr> <tr> <td>0</td> <td>1</td> <td>Format 5 (RGB) CCIR level</td> <td>active, no indexed colour</td> <td>active</td> <td>CCIR level</td> </tr> <tr> <td>1</td> <td>X</td> <td>Format 7 (indexed colour) CCIR level</td> <td>active, indexed colour</td> <td>active</td> <td>CCIR level</td> </tr> </tbody> </table>	Set by bits		in function blocks				MPKC1	MPKC0	input formatter	CLUTs	matrix	level matching	0	0	control via CCIR bit and FMT bits	bypass	control via FMT bits	control via CCIR bit	0	1	Format 5 (RGB) CCIR level	active, no indexed colour	active	CCIR level	1	X	Format 7 (indexed colour) CCIR level	active, indexed colour	active	CCIR level
Set by bits		in function blocks																													
MPKC1	MPKC0	input formatter	CLUTs	matrix	level matching																										
0	0	control via CCIR bit and FMT bits	bypass	control via FMT bits	control via CCIR bit																										
0	1	Format 5 (RGB) CCIR level	active, no indexed colour	active	CCIR level																										
1	X	Format 7 (indexed colour) CCIR level	active, indexed colour	active	CCIR level																										
IEPI	Polarity of external PAL-ID signal (H/2 signal) from RTCI input (pin 57): 0 = not inverted; 1 = inverted																														
RTSC	<p>Real-time select control:</p> <p>0 = Real-time control HPLL increment is selected, that means, information about actual clock frequency from the digital colour decoder is received (SAA7151B or SAA7191B); the corresponding subcarrier frequency is calculated.</p> <p>1 = Real-time control FSC increment with PAL-ID is selected, that means, information about actual subcarrier frequency and PAL-ID from the digital colour decoder is received (SAA7151B or SAA7191B).</p>																														
RTIN	Select real-time control input: 0 = pin 57 is input for RTCI signal 1 = pin 57 is port output GPSW.																														
RTCE	Real-time control enabled: 0 = disabled; 1 = enabled (RTIN = 0)																														
Index "0C" CHPS7 to CHPS0	Phase adjustment between chrominance output signal and reference: 00 to FF equals 0° to 358.59375° in steps of 1.40625°.																														
Index "0D" FSC7 to FSC0	Fine adjustment of subcarrier frequency in non-GENLOCK modes: 00 to 7F increasing and FF to 80 decreasing equal approximately $\pm 450 \times 10^{-6}$ of the subcarrier frequency in 256 steps.																														
Index "0E" CLCK	Lock to external chrominance (to be read): 0 = possible; 1 = not possible.																														

# Digital video encoder, GENLOCK-capable

## SAA7199B

STD3 to STD0	Colour encoding standards:				standard
	STD3	STD2	STD1	STD0	
	0	0	0	0	NTSC 4.43; 60 Hz; SQP (12.27 MHz)
	0	0	0	1	NTSC 4.43; 50 Hz; SQP (14.75 MHz)
	0	0	1	0	PAL-B/G 4.43; 50 Hz; SQP (14.75 MHz)
	0	0	1	1	NTSC 4.43; 60 Hz; CCIR (13.5 MHz)
	0	1	0	0	NTSC 4.43; 50 Hz; CCIR (13.5 MHz)
	0	1	0	1	PAL-B/G 4.43; 50 Hz; CCIR (13.5 MHz)
	0	1	1	0	reserved
	0	1	1	1	reserved
	1	0	0	0	PAL-M; 60 Hz; SQP (12.27 MHz)
	1	0	0	1	PAL-M; 60 Hz; CCIR (13.5 MHz)
	1	0	1	0	PAL-N; 50 Hz; CCIR (13.5 MHz)
	1	0	1	1	PAL-N; 50 Hz; SQP (14.75 MHz)
	1	1	0	0	NTSC-M; 60 Hz; SQP (12.27 MHz)
	1	1	0	1	NTSC-M; 60 Hz; CCIR (13.5 MHz)
	1	1	1	0	reserved
	1	1	1	1	reserved

Status bits to be read via I <sup>2</sup> C-bus:	Table 7
Status bits to be read by microcontroller :	All registers from 00 up to 0F can be read via MPU-bus. Read-only bits are OEF, HCLK (index "04") and CLCK (index "0E")

### Note to Table 6

Field blanking (Figures 11 and 12): normally, video to be encoded should not become active after the active edge of VSN or CSYN before line 22.5 at 50 Hz (line 18 at 60 Hz). Total internal field blanking is 11 lines at 50 Hz (13 lines at 60 Hz).

### Colour look-up tables (CLUTs)

The CLUTs consist of RAM tables. The RAM tables can be loaded – with  $X = 0$  to 255 according to equation 1 – for the signals R, G and B. Gamma-correction (pre-distortion) by following equation:

$$Y = \text{NINT}(b + a \times X^{1/9}); \quad Y(X \leq 16) = 16; \quad Y(X \geq 235) = 235 \quad (\text{equation 1})$$

$$\text{with } g = 2.2 \text{ is} \quad a = 219 / (235^{2.2} - 16^{2.2})$$

$$b = 16 - a \times 16^{2.2}$$

The RAM tables are loaded via MPU-bus or via I<sup>2</sup>C-bus (Table 8).

# Digital video encoder, GENLOCK-capable

SAA7199B

## I<sup>2</sup>C-BUS FORMAT

S	SLAVE ADDRESS	A	SUBADDRESS	A	DATA0	A	DATA <sub>n</sub>	A	P
---	---------------	---	------------	---	-------	---	-------------------	---	---

S	=	start condition
SLAVE ADDRESS	=	1011 000X
A	=	acknowledge, generated by the slave
SUBADDRESS*	=	subaddress byte (Table 8)
DATA	=	data byte (Table 5)
P	=	stop condition
X	=	read/write control bit
		X = 0, order to write (the circuit is slave receiver)
		X = 1, order to read (the circuit is slave transmitter)

\* If more than 1 byte DATA are transmitted, then auto-increment of the subaddress is performed.

**Table 7** I<sup>2</sup>C-bus status byte (address byte "B1")

FUNCTION	STATUS BYTE							
	D7	D6	D5	D4	D3	D2	D1	D0
Read status	0	0	0	0	FFOS	OEF	CLCK	HLCK

Function of the bits:

FFOS	first field of sequence: 0 = false; 1 = first of 4 fields for NTSC (first of 8 fields for PAL). FFOS is not valid for non-interlaced signals.
OEF	field organization: 0 = even field; 1 = odd field
CLCK	possibility of lock to external chrominance: 0 = possible; 1 = not possible
HLCK	sync indication: 0 = locked to external sync; 1 = external sync lost.

**Table 8** I<sup>2</sup>C-bus write bytes (address byte "B0")

<b>ACCESS TO CONTROL REGISTERS</b> Address byte "B0" — subaddress byte "02" — index byte (00 to 0F, Table 5) — data bytes (auto-increment)
<b>ACCESS TO CLUTS REGISTERS</b> Address byte "B0" — subaddress byte "00" — CLUT address bytes (00 to FF) — 3 data bytes for one RGB sequence (auto-increment)

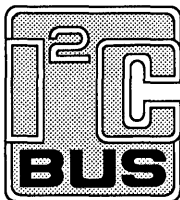

Purchase of Philips' I<sup>2</sup>C components conveys a license under the Philips' I<sup>2</sup>C patent to use the components in the I<sup>2</sup>C-system provided the system conforms to the I<sup>2</sup>C specifications defined by Philips.

## Digital video encoder, GENLOCK-capable

SAA7199B

Table 9 Four different modes

<p><b>STAND-ALONE MODE</b></p> <p>The SAA7199B receives a line-locked clock CLKIN and generates CSYN or HSN/VSN output signals, which trigger the RGB respectively the YUV source signal to provide data and composite blanking CBN.</p>
<p><b>SLAVE MODE</b></p> <p>The SAA7199B receives the line-locked clock CLKIN, CSYN or HSN/VSN, CBN and data from an RGB respectively YUV source. The sync inputs are edge-sensitive; the minimum active length is 1 PIXCLK. Optionally, a real-time control signal RTCI is received from a digital colour decoder.</p>
<p><b>GENLOCK MODE</b></p> <p>Horizontal and vertical sync as well as colour are locked on a received CVBS reference signal. The CVBS reference signal generates also a line-locked clock by the SAA7197 clock generator. Auxiliary signals HCL and HSY as well as CSYN or HSN/VSN are generated to trigger the RGB respectively the YUV source providing data and composite blanking CBN.</p>
<p><b>TEST MODE</b></p> <p>Like stand-alone mode, but data to be encoded are the contents of the test registers TRER, TREG and TREB. VSN/CSYN and HSN outputs are in 3-state condition.</p>

### Relationship between horizontal frequency and colour subcarrier frequency in non-GENLOCK mode

a) Internal subcarrier frequency with  $n = \text{integer}$ :

$$\text{PAL: } f_{\text{SC}} = f_{\text{H}}(n/4 + 1/625) \text{ respectively } f_{\text{H}}(n/4 + 1/525) \quad \text{NTSC: } f_{\text{SC}} = f_{\text{H}}(n/2)$$

Necessary conditions: Non-GENLOCK mode; RTCE = 0, FSCO = 00h; phase coupling of the two frequencies is given by definite phase reset every 8th fields at PAL (4th fields at NTSC).

FSCO  $\neq$  00h adjusts the subcarrier frequency, phase reset is disabled and phase between  $f_{\text{SC}}$  and  $f_{\text{H}}$  is not constant.

b) External subcarrier frequency:

$f_{\text{SC}}$  is given by RTCI real-time input from a digital colour decoder.

Necessary conditions: Slave mode; RTCE = 1, RTSC = 1. The 8th respectively 4th field reset is enabled at FSCO = 00h (disabled at FSCO  $\neq$  00h). The subcarrier frequency itself is not influenced by FSCO bits, it is given by real-time increment.

c) External HPLL increment:

$f_{\text{SC}}$  is calculated by means of RTCI real-time input signal from a digital colour decoder. The frequency of  $f_{\text{SC}}$  depends on the absolute crystal frequency value used by the digital colour decoder.

Necessary conditions: Slave mode; RTCE = 1, RTSC = 0. The 8th respectively 4th field reset is enabled at FSCO = 00h (disabled at FSCO  $\neq$  00). The subcarrier frequency itself is influenced by FSCO bits.

The absolute phase relationship between sync and subcarrier (colour burst out) can be influenced in all three cases by CHPS(7-0) register byte (index "0C").

# Digital video encoder, GENLOCK-capable

## SAA7199B

### Data input formats

One clock cycle equals 12.27 MHz, 13.5 MHz or 14.75 MHz (Cb = (B-Y) equals U; Cr = (R-Y) equals V;  
(n) = number of pixel).

**Table 10** Format 0: DMSD2-compatible YUV 4:1:1 format (FMT-bits in index "00" = 000)

INPUT SIGNAL	CLOCK CYCLE (PIXEL SEQUENCE)							
	0	1	2	3	4	5	6	7
PD2(7-0)	Y(0)	Y(1)	Y(2)	Y(3)	Y(4)	Y(5)	Y(6)	Y(7)
PD3(7)	Cb7(0)	Cb5(0)	Cb3(0)	Cb1(0)	Cb7(4)	Cb5(4)	Cb3(4)	Cb1(4)
PD3(6)	Cb6(0)	Cb4(0)	Cb2(0)	Cb0(0)	Cb6(4)	Cb4(4)	Cb2(4)	Cb0(4)
PD3(5)	Cr7(0)	Cr5(0)	Cr3(0)	Cr1(0)	Cr7(4)	Cr5(4)	Cr3(4)	Cr1(4)
PD3(4)	Cr6(0)	Cr4(0)	Cr2(0)	Cr0(0)	Cr6(4)	Cr4(4)	Cr2(4)	Cr0(4)
PD3(3-0)	not used							
PD1(7-0)	not used							

**Table 11** Format 1: Customized YUV 4:1:1 format (FMT-bits in index "00" = 001)

INPUT SIGNAL	CLOCK CYCLE (PIXEL SEQUENCE)							
	0	1	2	3	4	5	6	7
PD2(7-0)	Y(0)	Y(1)	Y(2)	Y(3)	Y(4)	Y(5)	Y(6)	Y(7)
PD3(7)	Cb7(0)	-	Cr7(0)	-	Cb7(4)	-	Cr7(4)	-
PD3(6)	Cb6(0)	-	Cr6(0)	-	Cb6(4)	-	Cr6(4)	-
PD3(5)	Cb5(0)	-	Cr5(0)	-	Cb5(4)	-	Cr5(4)	-
PD3(4)	Cb4(0)	-	Cr4(0)	-	Cb4(4)	-	Cr4(4)	-
PD3(3)	Cb3(0)	-	Cr3(0)	-	Cb3(4)	-	Cr3(4)	-
PD3(2)	Cb2(0)	-	Cr2(0)	-	Cb2(4)	-	Cr2(4)	-
PD3(1)	Cb1(0)	-	Cr1(0)	-	Cb1(4)	-	Cr1(4)	-
PD3(0)	Cb0(0)	-	Cr0(0)	-	Cb0(4)	-	Cr0(4)	-
PD1(7-0)	not used							



# Digital video encoder, GENLOCK-capable

## SAA7199B

**Table 12** Format 2: DMSD2-compatible YUV 4:2:2 format (FMT-bits in index "00" = 010)

INPUT SIGNAL	CLOCK CYCLE (PIXEL SEQUENCE)							
	0	1	2	3	4	5	6	7
PD2(7-0)	Y(0)	Y(1)	Y(2)	Y(3)	Y(4)	Y(5)	Y(6)	Y(7)
PD3(7)	Cb7(0)	Cr7(0)	Cb7(2)	Cr7(2)	Cb7(4)	Cr7(4)	Cb7(6)	Cr7(6)
PD3(6)	Cb6(0)	Cr6(0)	Cb6(2)	Cr6(2)	Cb6(4)	Cr6(4)	Cb6(6)	Cr6(6)
PD3(5)	Cb5(0)	Cr5(0)	Cb5(2)	Cr5(2)	Cb5(4)	Cr5(4)	Cb5(6)	Cr5(6)
PD3(4)	Cb4(0)	Cr4(0)	Cb4(2)	Cr4(2)	Cb4(4)	Cr4(4)	Cb4(6)	Cr4(6)
PD3(3)	Cb3(0)	Cr3(0)	Cb3(2)	Cr3(2)	Cb3(4)	Cr3(4)	Cb3(6)	Cr3(6)
PD3(2)	Cb2(0)	Cr2(0)	Cb2(2)	Cr2(2)	Cb2(4)	Cr2(4)	Cb2(6)	Cr2(6)
PD3(1)	Cb1(0)	Cr1(0)	Cb1(2)	Cr1(2)	Cb1(4)	Cr1(4)	Cb1(6)	Cr1(6)
PD3(0)	Cb0(0)	Cr0(0)	Cb0(2)	Cr0(2)	Cb0(4)	Cr0(4)	Cb0(6)	Cr0(6)
PD1(7-0)	not used							

**Table 13** Format 3: Customized YUV 4:2:2 format (FMT-bits in index "00" = 011)

INPUT SIGNAL	CLOCK CYCLE (PIXEL SEQUENCE)							
	0	1	2	3	4	5	6	7
PD2(7-0)	Y(0)	Y(1)	Y(2)	Y(3)	Y(4)	Y(5)	Y(6)	Y(7)
PD3(7-0)	Cb (0)	-	Cb (2)	-	Cb (4)	-	Cb (6)	-
PD1(7-0)	Cr (0)	-	Cr (2)	-	Cr (4)	-	Cr (6)	-

**Table 14** Format 4: YUV 4:4:4 format (FMT-bits in index "00" = 100)

INPUT SIGNAL	CLOCK CYCLE (PIXEL SEQUENCE)							
	0	1	2	3	4	5	6	7
PD2(7-0)	Y(0)	Y(1)	Y(2)	Y(3)	Y(4)	Y(5)	Y(6)	Y(7)
PD3(7-0)	Cb (0)	Cb (1)	Cb (2)	Cb (3)	Cb (4)	Cb (5)	Cb (6)	Cb (7)
PD1(7-0)	Cr (0)	Cr (1)	Cr (2)	Cr (3)	Cr (4)	Cr (5)	Cr (6)	Cr (7)

**Table 15** Format 5: RGB 4:4:4 format (FMT-bits in index "00" = 101)

INPUT SIGNAL	CLOCK CYCLE (PIXEL SEQUENCE)							
	0	1	2	3	4	5	6	7
PD1(7-0)	R(0)	R(1)	R(2)	R(3)	R(4)	R(5)	R(6)	R(7)
PD2(7-0)	G(0)	G(1)	G(2)	G(3)	G(4)	G(5)	G(6)	G(7)
PD3(7-0)	B(0)	B(1)	B(2)	B(3)	B(4)	B(5)	B(6)	B(7)

**Table 16** Format 7: Indexed colour format (FMT-bits in index "00" = 111). Input codes 0 to 255 are allowed, output code of CLUTs should preferably be the same as given in Format 5

INPUT SIGNAL	CLOCK CYCLE (PIXEL SEQUENCE)							
	0	1	2	3	4	5	6	7
PD2(7-0)	INC(0)	INC(1)	INC(2)	INC(3)	INC(4)	INC(5)	INC(6)	INC(7)

# Digital video encoder, GENLOCK-capable

## SAA7199B

**Table 17** Input data levels for formats 0 to 4 and 5; EBU colour bar: 100 % white equals 100 IRE intensity; 75 % colour saturation for formats 1 to 4; 100 % for format 5

INPUT CHANNEL	LEVEL	DIGITAL LEVEL	CODE	CCIR-BIT	FORMAT
Y channel	0 IRE 100 IRE	12 230	offset binary	0	formats 0 to 4
Cb channel	bottom peak colourless top peak	-101 0 100	two's complement	0	formats 0 to 4
Cr channel	bottom peak colourless top peak	-106 0 105	two's complement	0	formats 0 to 4
Y channel	0 IRE 100 IRE	16 235	offset binary	1	formats 0 to 4
Cb channel	bottom peak colourless top peak	44 128 212	offset binary	1	formats 0 to 4
Cr channel	bottom peak colourless top peak	44 128 212	offset binary	1	formats 0 to 4
R, G and B	0 IRE 100 IRE	16 235	offset binary	1	format 5

### GENLOCK input data

**Table 18** Format 7: CVBS GENLOCK input data format has 8-bit word length. The input data come from an analog-to-digital converter (TDA8708) with gain-controlled and clamped CVBS or VBS signals

INPUT SIGNAL	CLOCK CYCLE (PIXEL SEQUENCE)							
	0	1	2	3	4	5	6	7
CVBS7 to CVBS0	CVBS(0)	CVBS(1)	CVBS(2)	CVBS(3)	CVBS(4)	CVBS(5)	CVBS(6)	CVBS(7)
CONDITIONS OF CVBS INPUT SIGNAL				TWO'S COMPLEMENT REPRESENTATION				
sync bottom				corresponding to binary code				-128
0 IRE (black)				corresponding to binary code				-64*
100 IRE (white)				corresponding to binary code				95
top peak of 75 % colour				corresponding to binary code				95
bottom peak of 75 % colour				corresponding to binary code				-100

\* If exactly matched levels are wanted in the internal multiplexer, the value 0 IRE should correspond to -68 and 100 IRE to 82.

# Digital video encoder, GENLOCK-capable

## SAA7199B

### Encoding data levels

Input data levels are transformed in three stages:

- in the matrix when RGB or indexed colour is applied (formats 5 and 7)
- in the normalizing amplifier depending on 50/60 Hz mode and CCIR-bit (index "00")
- in the modulator

**Table 19(a)** Y and C output levels in 50 Hz mode (PAL) for RGB input levels (100/100 colour bar)

SIGNAL	INPUT DATA			MATRIX OUTPUT DATA			NORMALIZER OUTPUT DATA			MODULATOR OUTPUT DATA	
	R	G	B	(R-Y)	Y	(B-Y)	V*	Y	U	Y	C**
white	235	235	235	128	235	128	0	421	0	421	0
yellow	235	235	16	146	210	16	29	387	-132	387	±135
cyan	16	235	235	16	170	166	-184	332	44	332	±189
green	16	235	16	34	145	54	-155	297	-87	297	±178
magenta	235	16	235	221	107	202	152	245	86	245	±175
red	235	16	16	240	82	90	183	211	-45	211	±188
blue	16	16	235	110	41	240	-30	154	131	154	±134
black	16	16	16	128	16	128	0	120	0	120	0
blanking	X	X	X	X	X	X	X	X	X	120	0
burst	X	X	X	X	X	X	45	X	-45	X	±63
top sync	X	X	X	X	X	X	X	X	X	0	X

**Table 19(b)** Y and C output levels in 60 Hz mode (NTSC) for RGB input levels (100/100 colour bar)

SIGNAL	INPUT DATA			MATRIX OUTPUT DATA			NORMALIZER OUTPUT DATA			MODULATOR OUTPUT DATA	
	R	G	B	(R-Y)	Y	(B-Y)	V	Y	U	Y	C**
white	235	235	235	128	235	128	0	416	0	416	0
yellow	235	235	16	146	210	16	29	385	-132	385	±135
cyan	16	235	235	16	170	166	-184	335	44	335	±189
green	16	235	16	34	145	54	-155	303	-87	303	±178
magenta	235	16	235	221	107	202	152	256	86	256	±175
red	235	16	16	240	82	90	183	225	-45	225	±188
blue	16	16	235	110	41	240	-30	173	131	173	±134
black	16	16	16	128	16	128	0	142	0	142	0
blanking	X	X	X	X	X	X	X	X	X	120	0
burst	X	X	X	X	X	X	0	X	-64	X	±64
top sync	X	X	X	X	X	X	X	X	X	0	X

X = not defined; \* the V component is inverted in the PAL line; \*\* the ± figures are peak values of the subcarrier signal.

# Digital video encoder, GENLOCK-capable

SAA7199B

### Chrominance filtering in the encoder

1. Decimation for 4:4:4 formats input data (Formats 4, 5 and 7; Fig.4).
2. Interpolation for 4:1:1 input data into 4:2:2 data – also suitable to reduce the bandwidth of 4:2:2 data. This filter is controlled by SCBW-bit (SCBW = 1 means active).
3. Interpolation at 13.5 MHz for 4:2:2 input data into 4:4:4 data before modulating baseband signals onto the colour subcarrier. Figures 5, 6 and 7 show the overall transfer characteristics of chrominance in "standard bandwidth condition" (SCBW = 1). Figures 8 and 9 show the overall transfer characteristics of chrominance in "enhanced bandwidth condition" (SCBW = 0), which is not possible for 4:1:1 input data. The transfer curves are slightly different at 12.27 and 14.75 MHz.

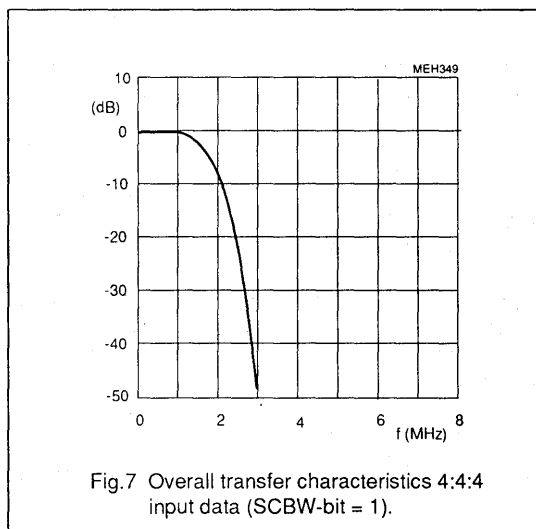
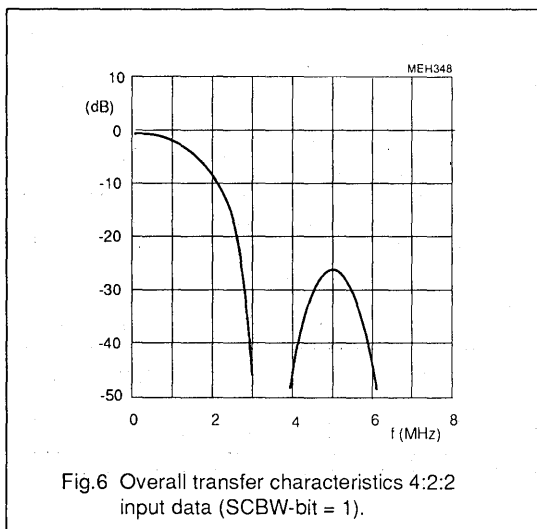
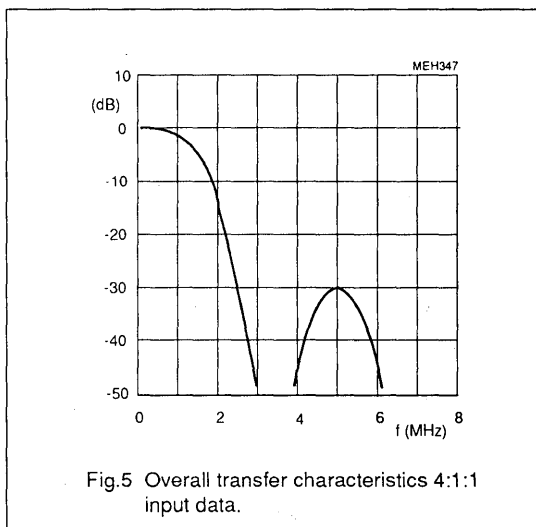
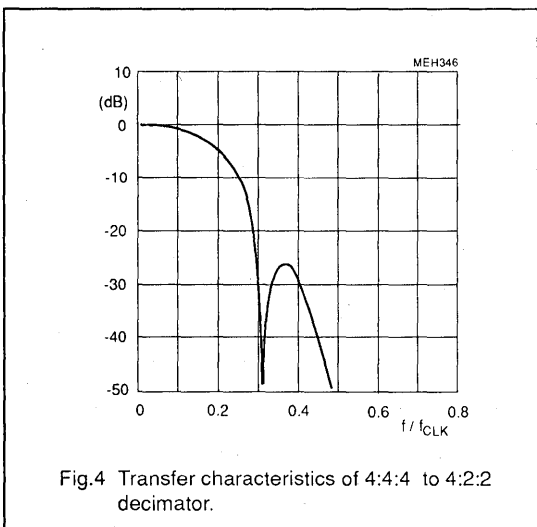

# Digital video encoder, GENLOCK-capable

## SAA7199B

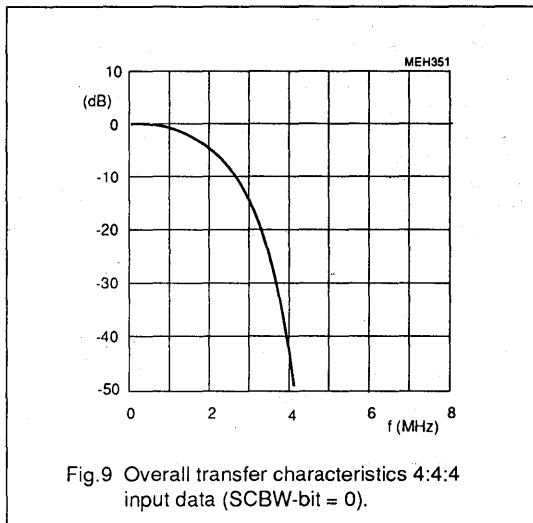
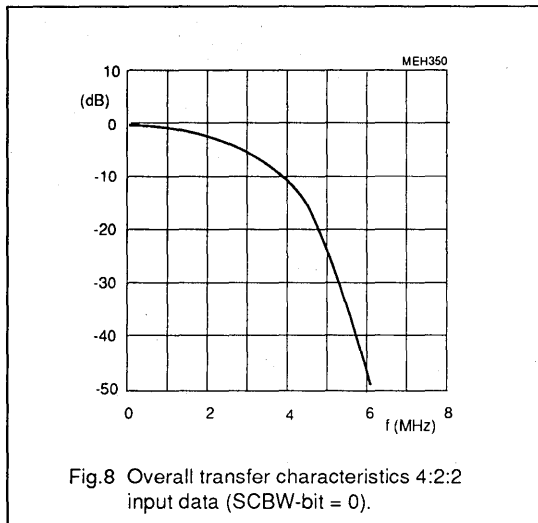

### Accuracy of matrix

Evaluation of quantization errors.

The RGB to YUV matrix is realized according to the following algorithm:

$$Y = \text{INT} ((\text{NINT}(R \times 2 \times 0.299) + \text{NINT}(G \times 2 \times 0.587) + \text{NINT}(B \times 2 \times 0.114)) / 2)$$

$$U = \text{NINT} ((B - Y) \times 0.57722)$$

$$V = \text{NINT} ((R - Y) \times 0.72955)$$

Errors can occur in the calculation of Y, which in consequence influence the U and V outputs.

The greatest positive error occurs, if in all of the three for Y calculation used ROMs the values are rounded up to 0.5 LSB, and no truncation error of 0.5 LSB is generated after summation:

$$(3 \times 0,5 \text{ LSB}) / 2 = +0.75 \text{ LSB};$$

$$\text{with truncation "error": } (3 \times 0,5 \text{ LSB}) / 2 - 0.5 \text{ LSB} = +0.25 \text{ LSB}.$$

The greatest negative error occurs at rounding off in all the three ROMs and by consecutive truncation:

$$3 \times (-0,5 \text{ LSB}) / 2 - 0.5 \text{ LSB} = -1.25 \text{ LSB}.$$

As a result, the matrix error can be  $\pm 1$  digit, which corresponds to approximately  $\pm 0.5\%$  differential non-linearity.

### Estimation of noise by quantization

The sum of all squared quantization errors is SS normalized to  $220^3$  input combinations (3-dimensional colour scale).

$$SS = 0.187545 \text{ LSB}^2.$$

Compared with noise energy for ideal quantization,  $SSI = 1/12 \text{ LSB}^2$  results in a deterioration by the conversion matrix of

$$D = 10 \log (0.187545 \times 12) = 3.5 \text{ dB (equals 0.5 bit)}.$$

If SS is the sum of all squared quantization errors, normalized to 220 input combinations of a grey-scale ( $R = G = B$ ), then is

$$SS = 0.12273 \text{ LSB}^2.$$

Compared with noise energy for ideal quantization,  $SSI = 1/12 \text{ LSB}^2$  results in a deterioration by the conversion matrix of

$$D = 10 \log (0.12273 \times 12) = 1.7 \text{ dB (equals 0.25 bit)}.$$

# Digital video encoder, GENLOCK-capable

## SAA7199B

### Normalizing amplifiers in luminance channel

The absolute amplification error for 50 Hz non-set-up signals is 0.375 %; differential non-linearity is  $-0.333$  % (equals  $-1$  LSB).

The absolute amplification error for 60 Hz set-up signals is  $-1.5$  %; differential non-linearity is  $-0.365$  % (equals  $-1$  LSB).

### Normalizing amplifiers in chrominance channel

The absolute amplification error is approximately  $\pm 0.5$  % with a truncation error of  $-0.5$  LSB.

The subcarrier amplitude for standards with luminance set-up is the same as for the standards without luminance set-up.

### Modulator

The absolute amplification error is  $-0.39$  %; there is no truncation error.

### Functional timing

GENLOCK mode:

The encoded signal can be generated earlier with respect to CVBS(7-0) bits (offset  $t_{ofs}$  set by GDC-bits; index "05"). The HSN output signal can be generated early by PSO-bits (index "07") with respect

to CBN to compensate for pipelining delay  $t_{Rint}$  of the RAM interface (valid also in stand-alone mode).

The horizontal timing is independent of active video at data inputs PDn(7-0). The line blanking period on the outputs is set to approximately  $12 \mu\text{s}$  in 50 Hz standards ( $11 \mu\text{s}$  in 60 Hz standards).

Slave mode:

HSN pin is used as an input. The active edge of the input signal is assumed to fit to the incoming CBN signal. Deviations can be compensated in the range of the GCD-bits (index "05").

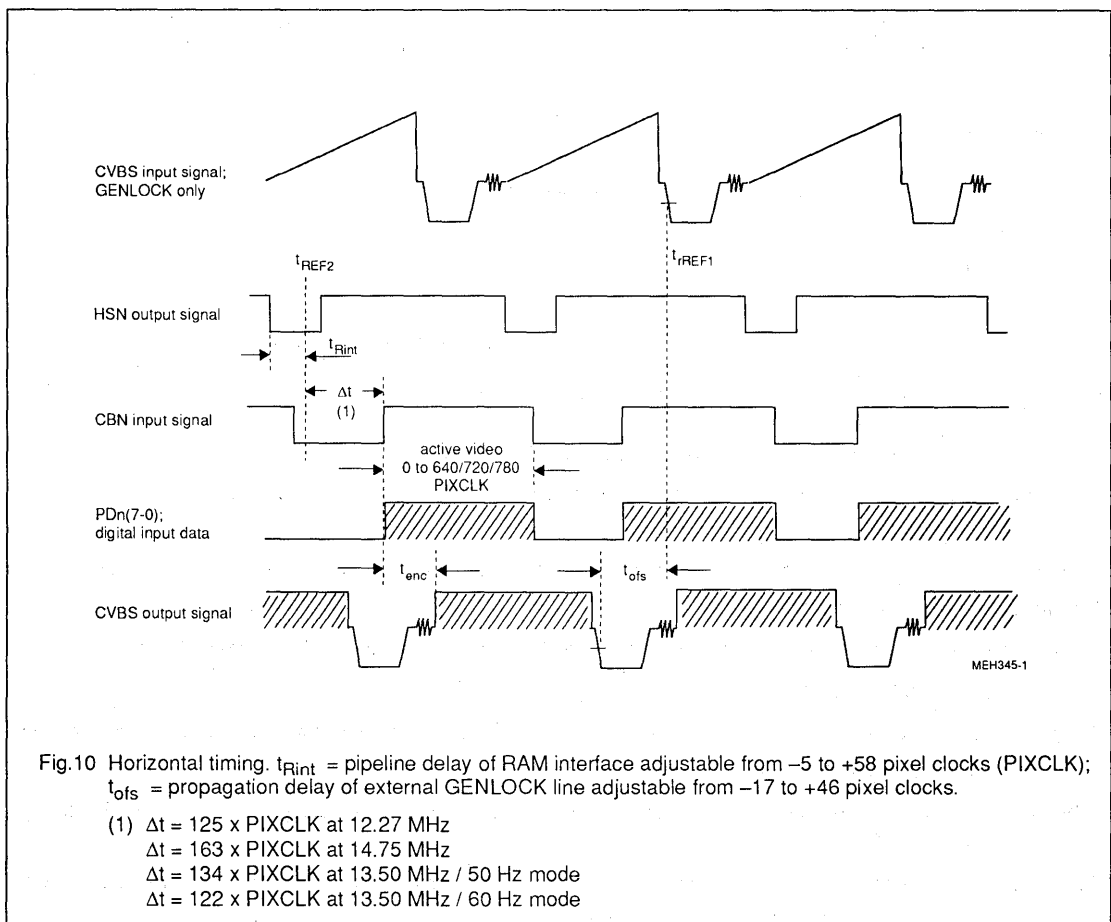

# Digital video encoder, GENLOCK-capable

**SAA7199B**

The  $t_{enc}$  time is the total delay from data input to analog CVBS output; it is 55 pixel clock periods long (PIXCLK) plus the propagation delay of the LDV input register regardless of mode and colour standard.

The key input signal is delay-compensated with respect to PDn(7-0) data input. The generated vertical field and burst blanking sequences are shown in Fig.11 (50 Hz PAL) and Fig.12 (60 Hz NTSC).

### Reset

Prior to a reset all outputs are undefined. RESN = LOW sets the circuit into the slave mode: MOD1 bit = 1; MOD0-bit = 0. All

other control register bits are set to zero. The outputs CSYN/VSN, HSN, SLT, HSY and HCL are automatically set to high-impedance state. The I<sup>2</sup>C-bus interface is set to a slave receiver.

The D(7-0) pins of the MPU interface are inputs during RESN = LOW. As the circuit requires an external clock signal on pin CLKIN in slave mode, the clock select signal CLKSEL (pin 50) must be LOW during RESN = LOW (pin 54). The LOW time of RESN is preliminary at least 50 pixel clock periods long.

### Disable chip

All analog outputs are set to zero by DD-bit = 1 (index "08"); while the

outputs CSYN/VSN, HSN, HCL, HSY and SLT are set to high-impedance state. The internal clock is divided by 4 at DD-bit = 1.

The circuit can be disabled for any reason. It must be disabled when CLKIN exceeds 32 MHz. After setting DD-bit = 1, the CLKIN input signal can be set to a frequency of < 60 MHz (modification of control registers and RAM tables is not ensured).

To enable the circuit again, CLKIN must be set to a frequency < 32 MHz, a reset (hardware) then is required to set DD-bit to zero.

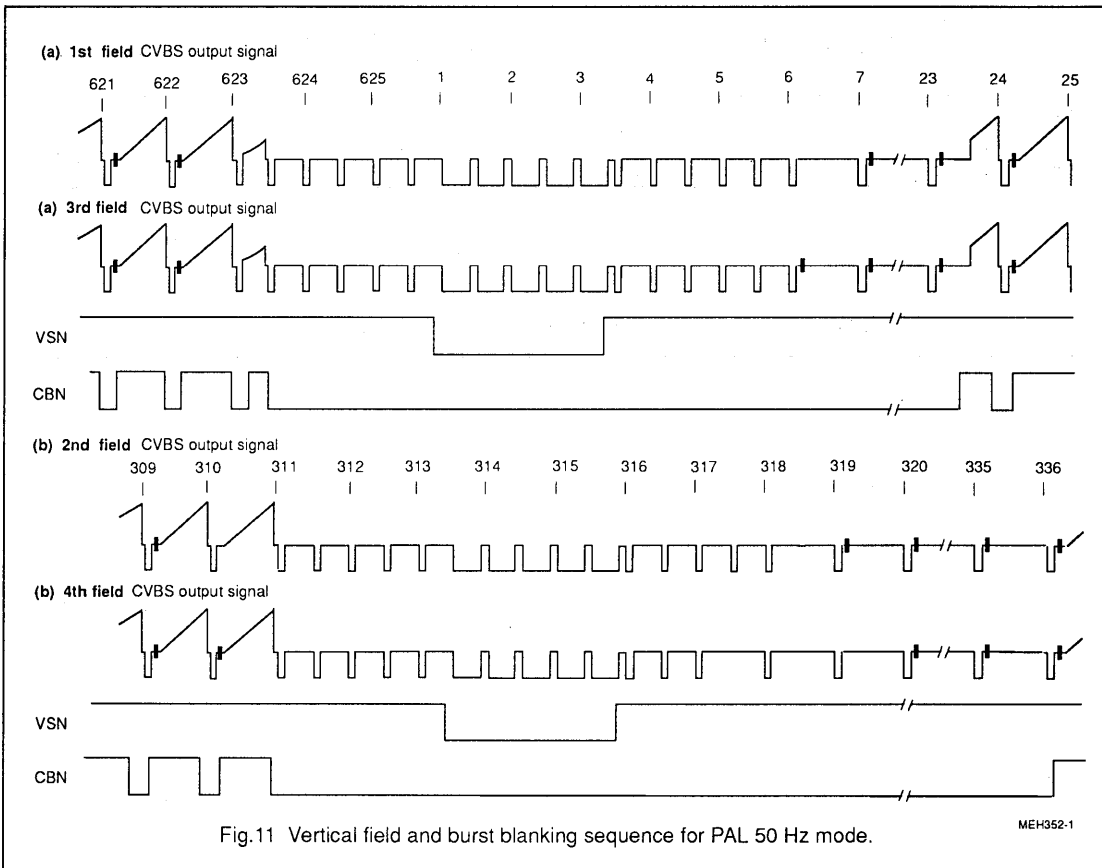

Fig.11 Vertical field and burst blanking sequence for PAL 50 Hz mode.

MEH352-1

# Digital video encoder, GENLOCK-capable

## SAA7199B

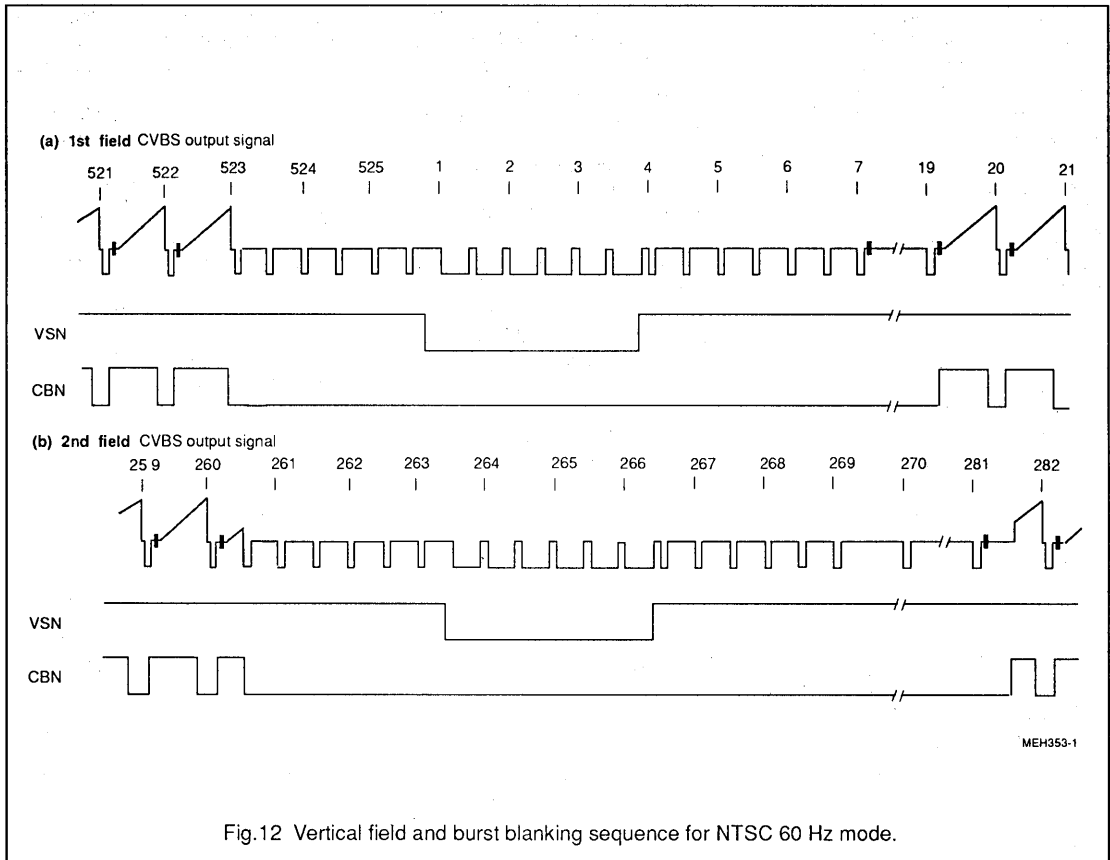

Fig.12 Vertical field and burst blanking sequence for NTSC 60 Hz mode.



# Digital video encoder, GENLOCK-capable

SAA7199B

## LIMITING VALUES

In accordance with the Absolute Maximum Rating System (IEC 134).

SYMBOL	PARAMETER	MIN.	MAX.	UNIT
V <sub>DD1</sub>	supply voltage (pin 2)	-0.3	7	V
V <sub>DD2</sub>	supply voltage (pin 21)	-0.3	7	V
V <sub>DD3</sub>	supply voltage (pin 41)	-0.3	7	V
V <sub>DDA1</sub>	supply voltage (pin 66)	-0.3	7	V
V <sub>DDA2</sub>	supply voltage (pin 70)	-0.3	7	V
V <sub>DDA3</sub>	supply voltage (pin 72)	-0.3	7	V
V <sub>DDA4</sub>	supply voltage (pin 64)	-0.3	7	V
V <sub>diff GND</sub>	difference voltage between digital and analog ground pins (V <sub>DDn</sub> - V <sub>DDAn</sub> )	-	±100	mV
V <sub>n</sub>	voltage on all pins, grounds excluded	0	V <sub>P</sub>	V
P <sub>tot</sub>	total power dissipation	-	1.1	W
T <sub>stg</sub>	storage temperature range	-65	150	°C
T <sub>amb</sub>	operating ambient temperature range	0	70	°C
V <sub>ESD</sub>	electrostatic handling* for all pins	±2000	-	V

\* Equivalent to discharging a 100 pF capacitor through an 1.5 kΩ series resistor.

## CHARACTERISTICS

V<sub>DD</sub> = 4.5 to 5.5 V; V<sub>DDA</sub> = 4.75 to 5.25 V; T<sub>amb</sub> = 0 to 70 °C unless otherwise specified.

SYMBOL	PARAMETER	CONDITIONS	MIN.	TYP.	MAX.	UNIT
V <sub>DD</sub>	digital supply voltage range (pins 2, 21 and 42)		4.5	5	5.5	V
V <sub>DDA</sub>	analog supply voltage range (pins 66, 70 and 72)		4.75	5	5.25	V
I <sub>DD</sub>	digital supply current I <sub>DD1</sub> to I <sub>DD3</sub>	40 pF output load	-	-	140	mA
I <sub>DDA</sub>	analog supply current I <sub>DDA1</sub> to I <sub>DDA3</sub>	40 pF output load	-	-	60	mA
<b>Data and control inputs</b> (pins 3 to 20, 23 to 40, 43 to 46, 49, 50, 54 to 56, 59, 73 and 76 to 84)						
V <sub>IL</sub>	input voltage LOW	note 1	0	-	0.8	V
V <sub>IH</sub>	input voltage HIGH	note 1	2.0	-	V <sub>DD</sub> + 0.5	V
I <sub>LI</sub>	input leakage current		-	-	±1	μA

**Digital video encoder,  
GENLOCK-capable**
**SAA7199B**

SYMBOL	PARAMETER	CONDITIONS	MIN.	TYP.	MAX.	UNIT
C <sub>I</sub>	input capacitance	data inputs	-	-	8	pF
		CLKIN, LLC, LDV	-	-	10	pF
		3-state I/O	-	-	10	pF
<b>LFCO output (pin 61)</b>						
V <sub>o</sub>	output signal (peak-to-peak value)		1.4	-	2.6	V
V <sub>61</sub>	output voltage range		0	-	V <sub>DDD</sub>	V
<b>Data and other control outputs (pins 3, 51, 52, 57, 58, 60, 74 and 75)</b>						
V <sub>OL</sub>	output voltage LOW	note 2	0	-	0.6	V
V <sub>OH</sub>	output voltage HIGH	note 2	2.4	-	V <sub>DDD</sub>	V
<b>C, Y and CVBS analog outputs (pins 65, 67 and 69)</b>						
V <sub>o</sub>	output signal (peak-to-peak value)	without load; V <sub>DDA</sub> = 5 V	-	2	-	V
V <sub>65,67,69</sub>	minimum output voltage	without load; V <sub>DDA</sub> = 5 V	-	0.2	-	V
	maximum output voltage	without load; V <sub>DDA</sub> = 5 V	-	2.2	-	V
R <sub>65,67,69</sub>	internal serial output resistance	not tested	18	25	35	Ω
R <sub>L 65,67,69</sub>	output load resistance	recommendation	90	-	-	Ω
B	output signal bandwidth	-3 dB	10	-	-	MHz
ILE	LF integral linearity error	9-bit data	-	-	±1.0	LSB
DLE	LF differential linearity error	9-bit data	-	-	±0.5	LSB
I <sub>CUR</sub>	input current (pin 71)	Fig.1; R <sub>70-71</sub> = 20 kΩ	-	300	-	μA
<b>I<sup>2</sup>C-bus SDA and SCL (pins 47 and 48)</b>						
V <sub>IL</sub>	input voltage LOW		-0.5	-	1.5	V
V <sub>IH</sub>	input voltage HIGH		3.0	-	V <sub>DDD</sub> +0.5	V
I <sub>I</sub>	input current	V <sub>I</sub> = LOW or HIGH	-	-	±10	μA
V <sub>OL</sub>	SDA output voltage (pin 47)	I <sub>47</sub> = 3 mA	-	-	0.4	V
I <sub>47</sub>	output current	during acknowledge	3	-	-	mA
<b>Crystal oscillator</b>						
f <sub>n</sub>	nominal frequency	3rd harmonic; Table 1	-	24.576	-	MHz
		3rd harmonic; Table 1	-	26.8	-	MHz
Δf / f <sub>n</sub>	permissible deviation f <sub>n</sub>		-	50	-	10 <sup>-6</sup>
X1	crystal specification:	temperature range T <sub>amb</sub>	0	-	70	°C
		load capacitance C <sub>L</sub>	8	-	-	pF
		series resonance resistance R <sub>S</sub>	-	40	80	Ω
		motional capacitance C <sub>1</sub>	-	1.5±20%	-	fF
		parallel capacitance C <sub>0</sub>	-	3.5±20%	-	pF

**Digital video encoder,  
GENLOCK-capable**
**SAA7199B**

SYMBOL	PARAMETER	CONDITIONS	MIN.	TYP.	MAX.	UNIT
<b>LLC and LDV timing</b> (pins 55 and 20)		Fig.16				
$t_{LLC}$	cycle time	note 3	31.5	-	44.5	ns
$t_{CH}$	pulse width		40	50	60	%
$t_r$	rise time		-	-	5	ns
$t_f$	fall time		-	-	6	ns
$t_{LDV}$	cycle time		63	-	89	ns
$t_{SUL}$	LDV set-up time		4	-	-	ns
$t_{HDL}$	LDV hold time		10	-	-	ns
<b>PIXCLK and CLKO timing</b> (pins 51 and 52)		Fig.16				
$t_{DCK}$	PIXCLK and CLKO delay time		-	-	25	ns
<b>PD1(7-0), PD2(7-0), PD3(7-0), CBN, MPK, KEY and RTCl input timing</b> (pins 4 to 19, 23 to 32, 57 and 73)						
$t_{SUD}$	input data set-up time	Fig.16	4	-	-	ns
$t_{HDD}$	input data hold time		6	-	-	ns
<b>CVBS (7-0), VSN/CSYN and HSN timing</b> (pins 76 to 83, 3 and 84)						
$t_{SU}$	input data set-up time	Fig.17	10	-	-	ns
$t_{HD}$	input data hold time		5	-	-	ns
<b>CREF timing</b> (pin 56)		Fig.17				
$t_{SUC}$	input set-up time		10	-	-	ns
$t_{HDC}$	input hold time		2	-	-	ns
<b>MPU timing A1, A0, R/WN, CSN, D(7-0)</b> (pins 33 to 36, 37 to 40 and 43 to 46); Fig.18						
$t_{SA}$	A1 and A0 address set-up time (pins 33, 34)		4	-	-	ns
$t_{HA}$	A1 and A0 address hold time		25	-	-	ns
$t_{SR}$	R/WN set-up time (pin 35)		4	-	-	ns
$t_{HR}$	R/WN hold time		25	-	-	ns
$t_{CL}, t_{CH}$	CSN pulse width LOW and HIGH	note 4	95	-	-	ns
$t_{SW}$	data set-up time (D7 to D0)	write	80	-	-	ns
$t_{HW}$	data hold time (D7 to D0)	write	5	-	-	ns
$t_{HDR}$	data output hold time (D7 to D0)	read	5	-	-	ns
$t_{ZR}$	delay to driven ports (D7 to D0)	read	5	-	-	ns
$t_{DR}$	delay to ports valid (D7 to D0)	read; note 5	-	-	275	ns
$t_{RZ}$	port outputs disable time (D7 to D0)	read	-	-	25	ns
<b>Output timing</b> (pins 3, 74, 75 and 84)		Fig.17				
$t_{OD}$	output delay time	minimum clock period; note 6	-	20	40	ns

# Digital video encoder, GENLOCK-capable

## SAA7199B

### Notes to the characteristics

1. XTAL, XTALI and TP are not characterized with respect to levels; CLKO is characterized up to 32 MHz and PIXCLK up to 16 MHz
2. Levels are measured with load circuit. LFCO output with 10 kΩ in parallel to 15 pF and other outputs with 1.2 kΩ in parallel to 40 pF at 3V (TTL load).
3.  $t_{LLC}$  has to be in the range 63 to 89 ns at CREF = HIGH (pin 56);  $t_{LLC} = 16.5$  ns is allowed only if the multiplexer clock is active.
4.  $t_{PIXCLK(min)} + 5$  ns.
5.  $3 \times (t_{PIXCLK(min)} + 5$  ns).
6. 40 ns at low supply voltage (4 V) and high temperature (70 °C).

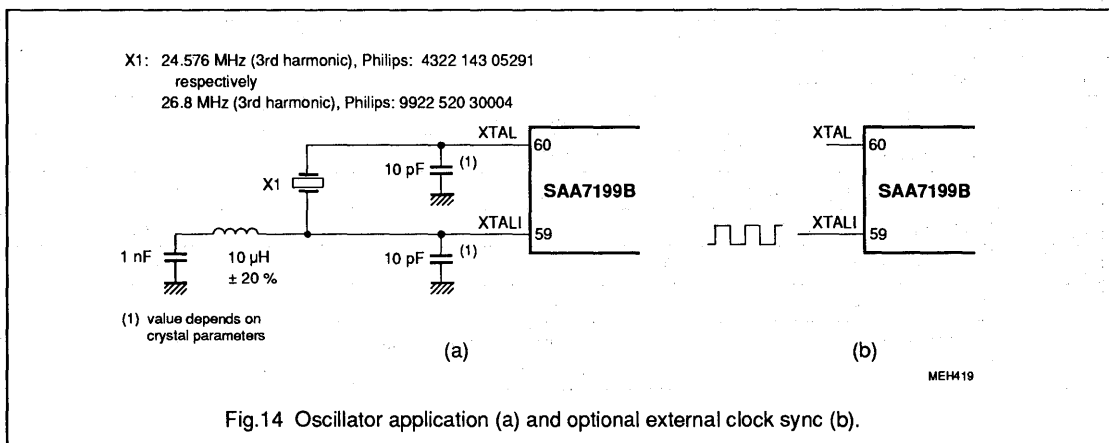
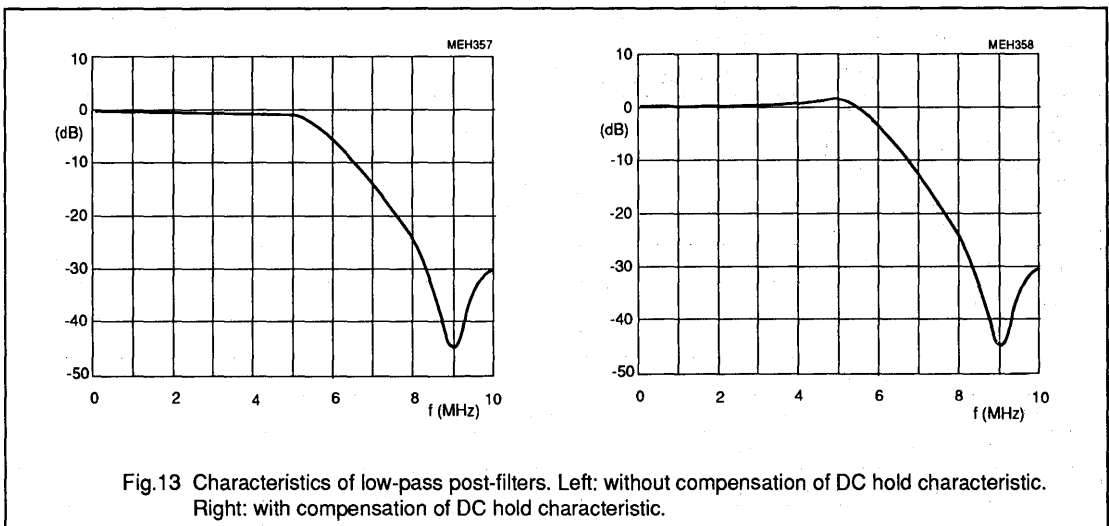

**Digital video encoder,  
GENLOCK-capable**

**SAA7199B**

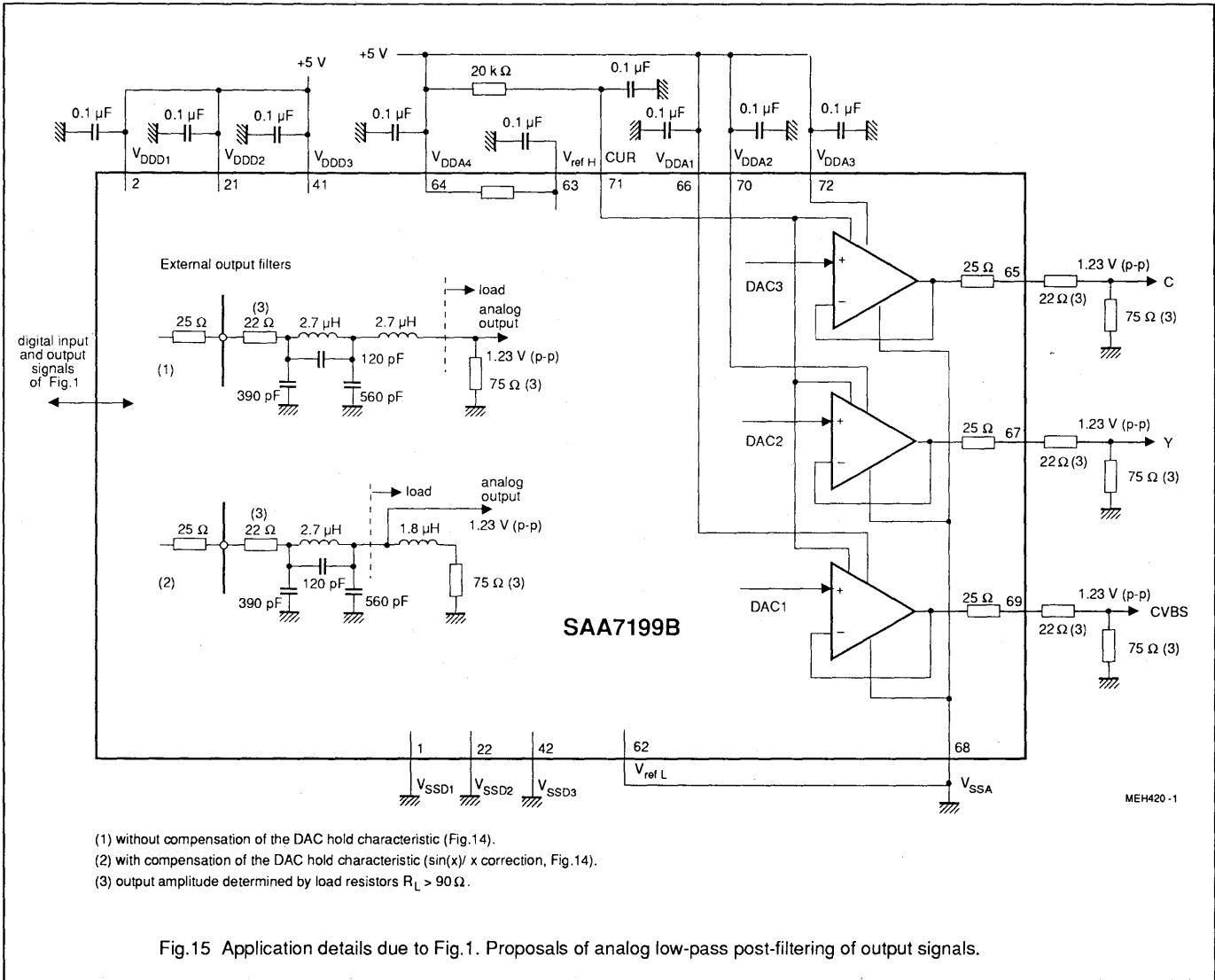

Digital video encoder,  
GENLOCK-capable

SAA7199B

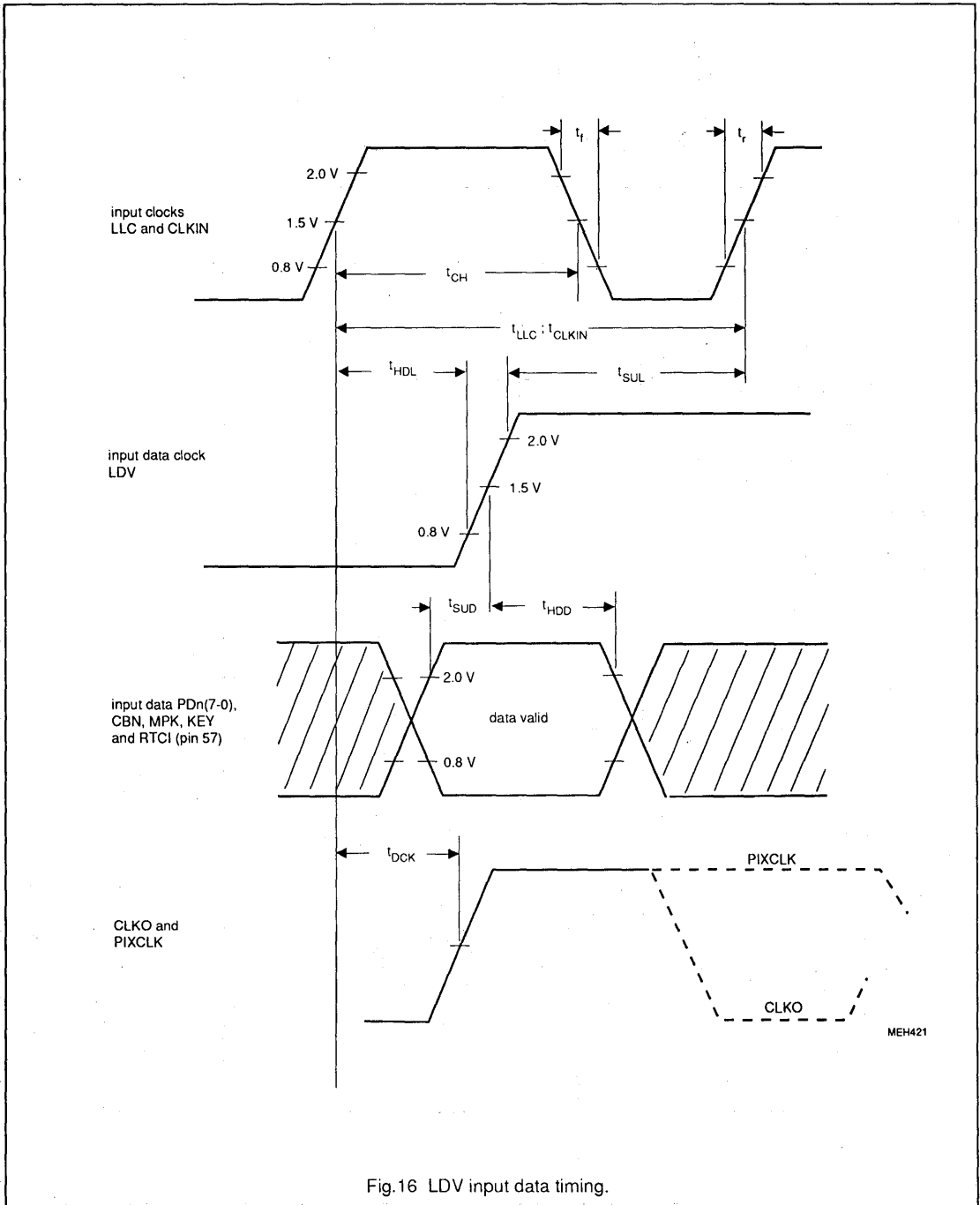
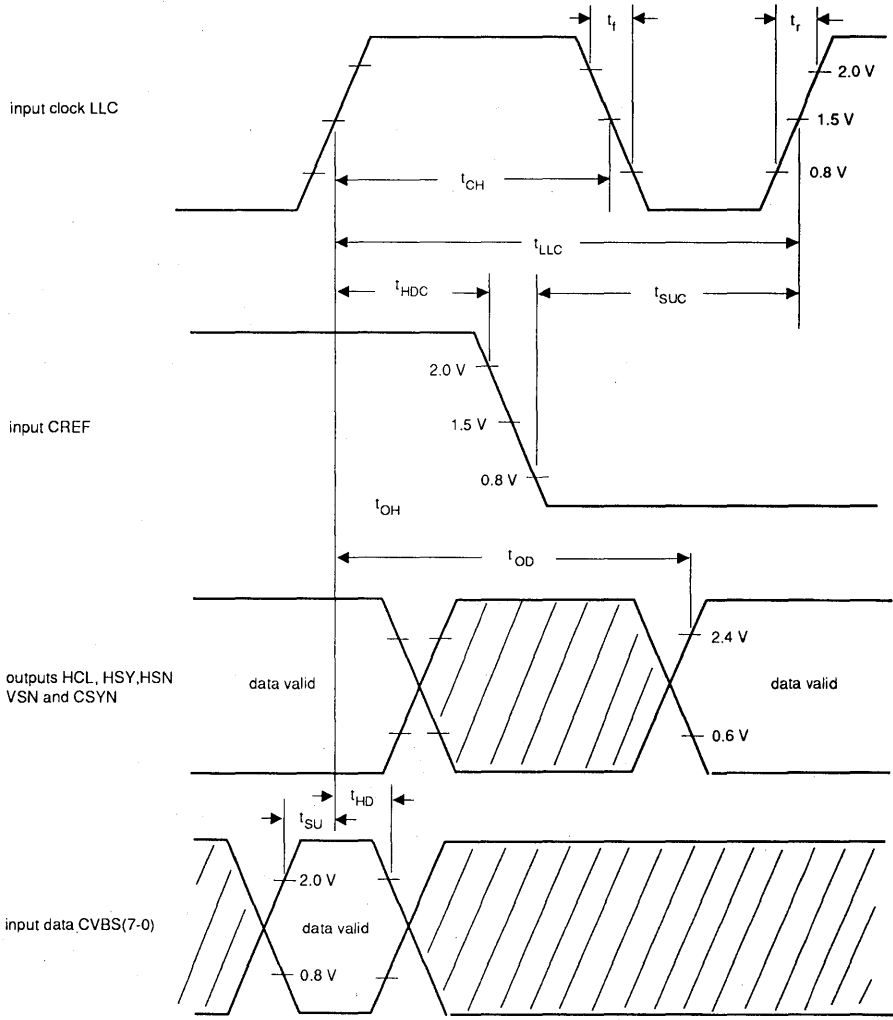

Fig.16 LDV input data timing.

Digital video encoder,  
GENLOCK-capable

SAA7199B



MEH355

Fig.17. Clock and data timing.

Digital video encoder,  
GENLOCK-capable

SAA7199B

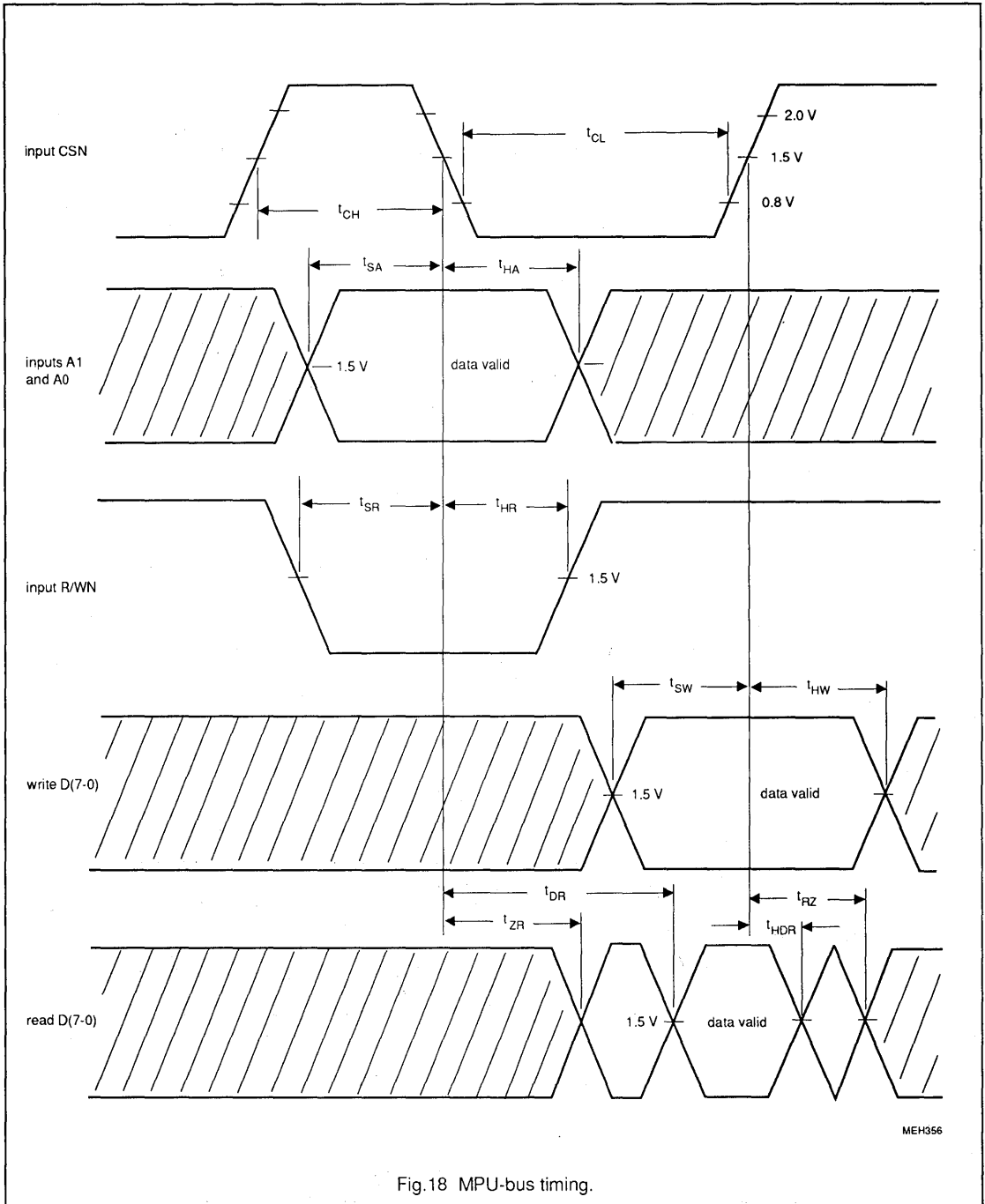

Fig.18 MPU-bus timing.



# Multi-standard Teletext IC for standard and features TV

## SAA9042

### FEATURES

#### General

- Interfaces with analog and digital TV systems
- Multi-media compatible
- Directly interfaces up to 1 Mbit dynamic RAM
- Fully independent acquisition and display timing
- 3 display modes
  - normal (1H/1V)
  - progressive scan (2H/1V)
  - 100 Hz/120 Hz (2H/2V)
- I<sup>2</sup>C-bus controlled
- Single 5 V power supply.

#### Acquisition

- Simultaneous update of up to 8 pages
- Up to 100 page background memory capability
- Software selectable 625/525 line operation
- Full Level-One Features (FLOF) operation
- Table Of Pages (TOP) compatible
- VCR Programming via Teletext (VPT) and Program Delivery Control (PDC) compatible
- Vertical Blanking Interval (VBI) and full channel operation
- Extension packets 26/27/28/29 and 30 fully decoded.

#### Display

- Stable display by slaving from scan-related timing signals
- Automatic selection of six different languages
- Versions for Western and Eastern Europe and Turkey
- Storage of 192 characters (13 × 10 dot matrix)
- Software controlled RGB level removes the need for hardware adjustment
- Up to 27 display rows; 0 to 24 and up to 2 status rows.

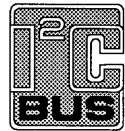

#### GENERAL DESCRIPTION

The SAA9042 is a CMOS integrated circuit designed for reception, decoding and display of 625 and 525 line World System Teletext (WST).

It is used in conjunction with a teletext video processor (SAA5191) for data regeneration, and a single-chip 64K × 4-bit or 256K × 4-bit dynamic RAM page memory.

The SAA9042 acquires teletext packets defined at levels 1, 2 and 3 in the WST specification and produces a level 1 display.

The device is microcontroller controlled via the standard I<sup>2</sup>C-bus and is compatible with analog, digital and features TV.

#### QUICK REFERENCE DATA

SYMBOL	PARAMETER	CONDITIONS	MIN.	TYP.	MAX.	UNIT
V <sub>DD</sub>	supply voltage		4.5	5.0	5.5	V
I <sub>DD</sub>	supply current		–	100	–	mA
f <sub>clk</sub>	clock frequency	625 line	–	6.9375	–	MHz
		525 line	–	5.7272	–	MHz
T <sub>amb</sub>	operating ambient temperature		–20	–	+70	°C

#### ORDERING INFORMATION

EXTENDED TYPE NUMBER	PACKAGE			
	PINS	PIN POSITION	MATERIAL	CODE
SAA9042	40	DIL	plastic	SOT129

Multi-standard Teletext IC for standard and features TV

SAA9042

BLOCK DIAGRAM

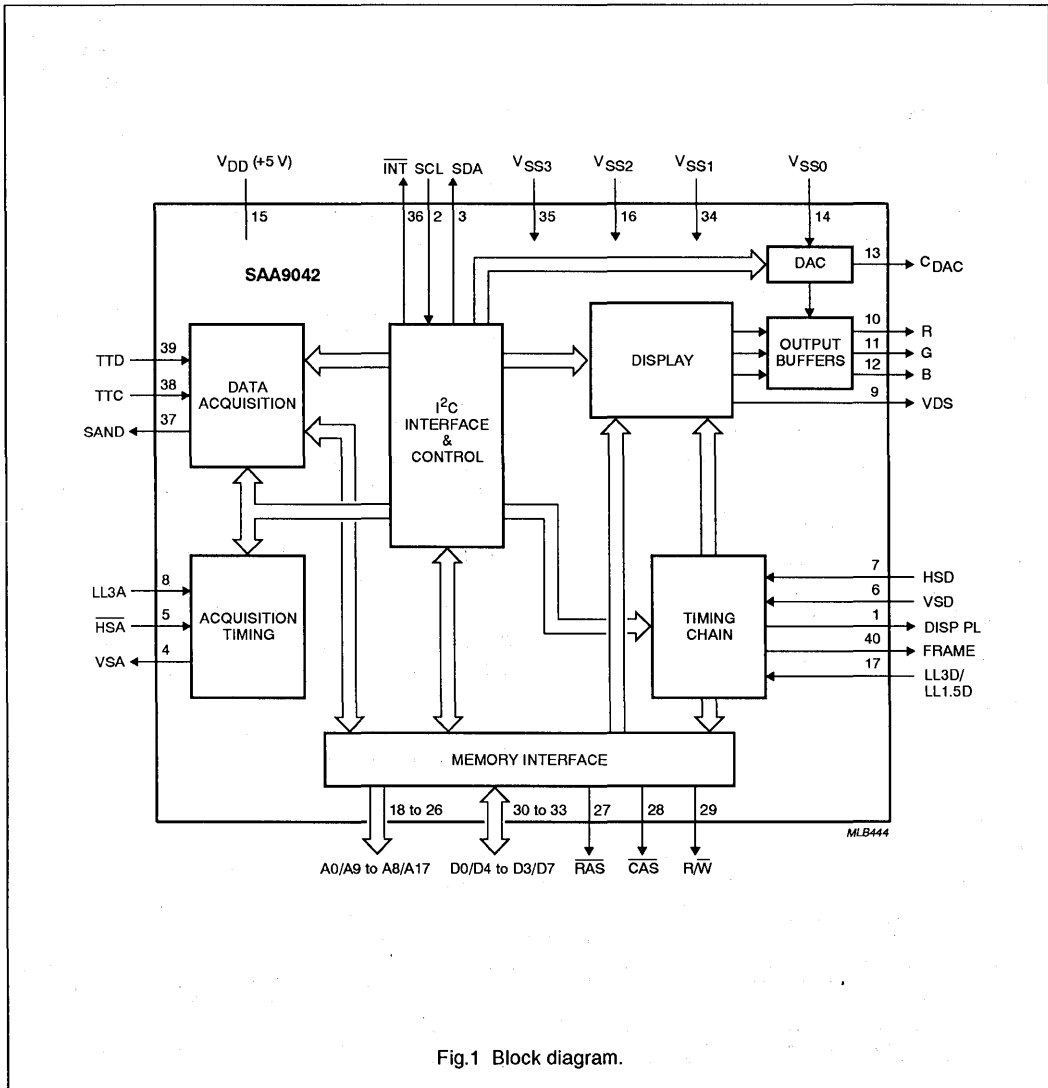

Fig.1 Block diagram.

# Multi-standard Teletext IC for standard and features TV

## SAA9042

### PINNING

SYMBOL	PIN	DESCRIPTION
DISP PL	1	Display PL: a programmable decode from the display-timing chain which can be used as a reference signal in an external PLL in scan-locked applications.
SCL	2	Serial Clock: input signal which is the I <sup>2</sup> C-bus clock from the microcontroller.
SDA	3	Serial Data: is the I <sup>2</sup> C-bus data line connected to the microcontroller. It is an input/output function with an open-drain output.
VSA	4	Vertical Synchronization Acquisition: synchronization signal from the SAA5191 (VCS), derived from the incoming video. This input enables field timing to be established in the acquisition section.
HSA	5	Horizontal Synchronization Acquisition: horizontal synchronization signal derived from the incoming video e.g. burst gate pulse. This active LOW input enables line timing to be established in the acquisition section.
VSD	6	Vertical Synchronization Display: synchronization signal indicating the vertical position of the TV picture. This input allows field synchronization of the display section.
HSD	7	Horizontal Synchronization Display: synchronization signal indicating the horizontal position of the TV picture. This input allows line synchronization of the TV picture.
LL3A	8	Line-Locked system clock: 13.5 MHz system clock input for the acquisition section.
VDS	9	Video/Data Switch: push-pull active HIGH 3-state output which controls the switching between text (HIGH) and normal TV (LOW) picture for both normal text and superimposed displays.
R	10	Red: analog 3-state output which contains video character and background information for text display. The output level is adjustable over 16 steps and is controlled by V <sub>SS0</sub> , V <sub>DD</sub> and an internal register.
G	11	Green: analog 3-state output which contains video character and background information for text display. The output level is adjustable over 16 steps and is controlled by V <sub>SS0</sub> , V <sub>DD</sub> and an internal register.
B	12	Blue: analog 3-state output which contains video character and background information for text display. The output level is adjustable over 16 steps and is controlled by V <sub>SS0</sub> , V <sub>DD</sub> and an internal register.
C <sub>DAC</sub>	13	DAC output: DAC output level, requires an external decoupling capacitor >1 µF.
V <sub>SS0</sub>	14	Ground: ground connection 0 for video outputs.
V <sub>DD</sub>	15	Power Supply: +5 V (typ.).
V <sub>SS2</sub>	16	Ground: ground connection 2.
LL3D/LL1.5D	17	Line-Locked system clock: 13.5 MHz or 27 MHz system clock input for the display, memory interface and control sections.
A0/A9 to A8/A17	18 to 26	Address: multiplexed address outputs for the external nibble-wide dynamic RAM (DRAM). With a 256 kbit (64K × 4) DRAM the address pin A8 is not used.
RAS	27	Row Address Strobe: active LOW output for the external DRAM.
CAS	28	Column Address Strobe: active LOW output for the external DRAM.
R/W	29	Read/Write: active LOW write enable signal for the external DRAM.
D3/D7 to D0/D4	30 to 33	Data: data inputs/outputs from the external nibble-wide DRAM.
V <sub>SS1</sub>	34	Ground: ground connection 1.
V <sub>SS3</sub>	35	Ground: ground connection 3.

Multi-standard Teletext IC for standard and  
features TV

SAA9042

SYMBOL	PIN	DESCRIPTION
$\overline{\text{INT}}$	36	Interrupt: open-drain active LOW output which provides an interrupt signal for a microcontroller indicating the arrival of a page or packet in any one of the acquisition channels, change in newsflash/subtitle status or power-on reset.
SAND	37	Sandcastle: 3-level output for the SAA5191 representing the $\overline{\text{PL/CBB}}$ signal, derived from the acquisition timing chain.
TTC	38	Teletext Clock: input from the SAA5191 supplied via an external coupling capacitor.
TTD	39	Teletext Data: input from the SAA5191 supplied via an external coupling capacitor, internally clamped to $V_{SS}$ for 4 to 8 $\mu\text{s}$ of each line to maintain the correct DC level.
FRAME	40	Frame: output for de-interlacing circuits. The signal is LOW for even fields and HIGH for odd fields when text but no picture is displayed. It is forced LOW when a TV picture is present.

Multi-standard Teletext IC for standard and features TV

SAA9042

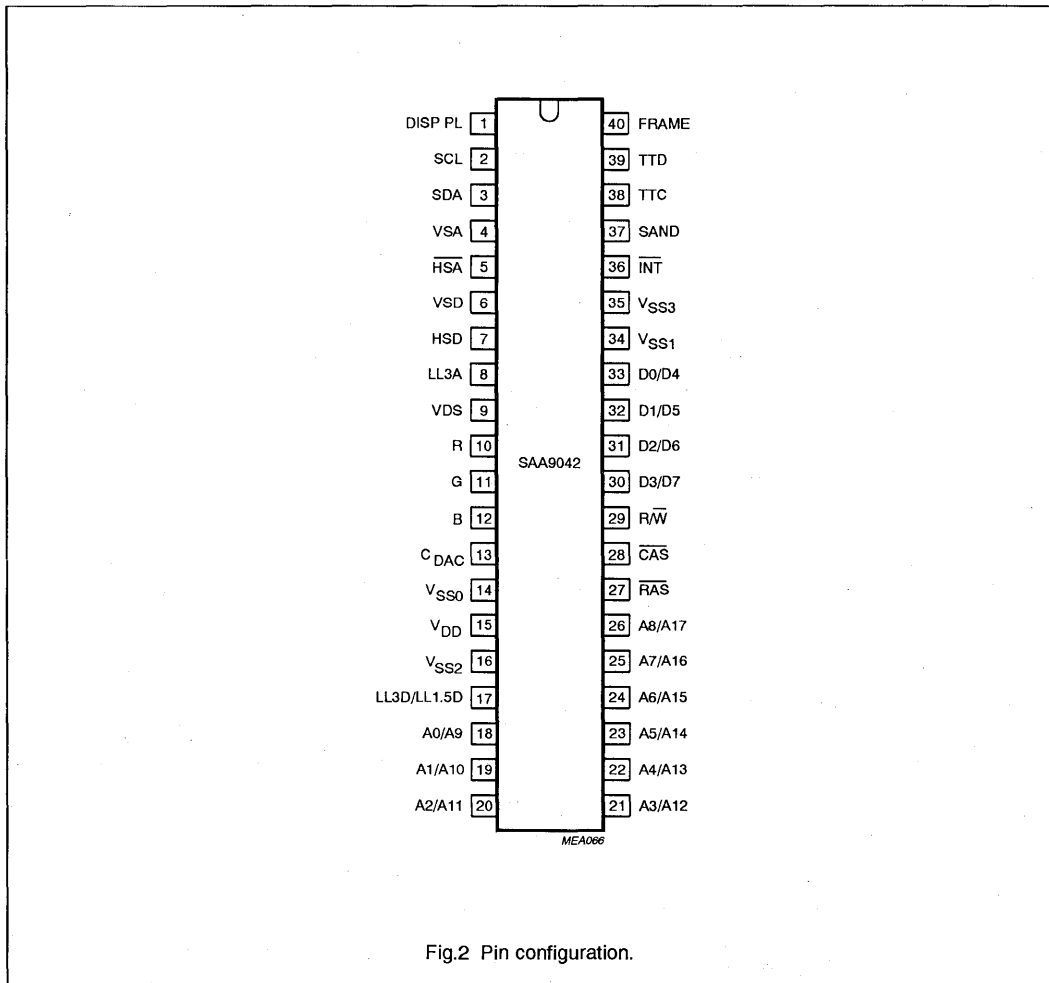

Fig.2 Pin configuration.

# Multi-standard Teletext IC for standard and features TV

SAA9042

## LIMITING VALUES

In accordance with the Absolute Maximum Rating System (IEC 134). All voltages are with respect to VSS1/2/3. VSS0 is considered as an output.

SYMBOL	PARAMETER	CONDITIONS	MIN.	MAX.	UNIT
V <sub>DD</sub>	DC supply voltage		-0.5	+6.5	V
I <sub>DD</sub>	DC supply current		tb <sub>f</sub>	tb <sub>f</sub>	mA
V <sub>I</sub>	DC input voltage		-0.5	V <sub>DD</sub> + 0.5	V
I <sub>I</sub>	DC input current		-20	+20	mA
V <sub>O</sub>	DC output voltage		-0.5	V <sub>DD</sub> + 0.5	V
I <sub>O</sub>	DC output current		-20	+20	mA
T <sub>stg</sub>	storage temperature		-65	+150	°C
T <sub>amb</sub>	operating ambient temperature		-20	+70	°C
V <sub>es</sub>	electrostatic handling	note 1	-1000	+1000	V

### Note

- Equivalent to discharging a 100 pF capacitor via a 1.5 kΩ series resistor with a rise time of 15 ns.

## HANDLING

Inputs and outputs are protected against electrostatic discharges in normal handling. However, to be totally safe, it is desirable to take normal precautions appropriate to handling integrated circuits.

## CHARACTERISTICS

V<sub>DD</sub> = 4.5 to 5.5 V; V<sub>SS1/2/3</sub> = 0 V; T<sub>amb</sub> = -20 to +70 °C; unless otherwise specified.

SYMBOL	PARAMETER	CONDITIONS	MIN.	TYP.	MAX.	UNIT
<b>Supply</b>						
V <sub>DD</sub>	DC supply voltage	note 1	4.5	5.0	5.5	V
I <sub>DD</sub>	DC supply current		-	100	-	mA
<b>Inputs; note 2</b>						
TTD; NOTE 3						
V <sub>I(p-p)</sub>	input voltage (peak-to-peak value)		2.0	-	5.0	V
C <sub>ext</sub>	external coupling capacitor		-	22	50	nF
t <sub>r</sub> , t <sub>f</sub>	input rise and fall times	notes 4 and 26	10	-	80	ns
t <sub>SU,DAT</sub>	input data set-up time	note 5	40	-	-	ns
t <sub>HD,DAT</sub>	input data hold up time	note 5	40	-	-	ns
I <sub>LI</sub>	input leakage current	V <sub>I</sub> = 0 to V <sub>DD</sub>	-10	-	+10	μA
C <sub>I</sub>	input capacitance	note 26	-	7	-	pF
t <sub>CLon</sub>	clamp start time	note 6	3.5	4.0	4.5	μs
t <sub>CLof</sub>	clamp finish time	note 6	7.5	8.0	8.5	μs
I <sub>CL</sub>	clamp output current	note 7	1.0	-	-	mA

## Multi-standard Teletext IC for standard and features TV

SAA9042

SYMBOL	PARAMETER	CONDITIONS	MIN.	TYP.	MAX.	UNIT
TTC; NOTE 8						
$V_{I(p-p)}$	input voltage (peak-to-peak value)		2.0	-	5.0	V
$C_{ext}$	external coupling capacitor		-	10	10	nF
$I_{IM}$	peak input current		-10	-	+10	mA
$V_{IM}$	input voltage (peak value) relative to 50% duty factor		$\pm 0.2$	-	$\pm 3.5$	V
$t_r, t_f$	input rise and fall times	notes 4 and 26	10	-	80	ns
$C_I$	input capacitance	note 26	-	7	-	pF
$V_{CL}$	input clamp voltage		1.2	1.4	1.6	V
$f_{clk}$	clock frequency	625 line	-	6.9375	-	MHz
		525 line	-	5.7272	-	MHz
HSA; NOTE 9						
$V_{IL}$	LOW level input voltage		0	-	0.8	V
$V_{IH}$	HIGH level input voltage		2.0	-	$V_{DD}$	V
$t_r, t_f$	input rise and fall times	notes 4 and 26	-	-	500	ns
$I_{LI}$	input leakage current	$V_I = 0$ to $V_{DD}$	-10	-	+10	$\mu A$
$C_I$	input capacitance	note 26	-	-	7	pF
VSA						
$V_{IL}$	LOW level input voltage		0	-	0.8	V
$V_{IH}$	HIGH level input voltage	note 27	2.0	-	$V_{DD}$	V
$t_r, t_f$	input rise and fall times	notes 4 and 26	-	-	500	ns
$I_{LI}$	input leakage current	$V_I = 0$ to $V_{DD}$	-10	-	+10	$\mu A$
$C_I$	input capacitance	note 26	-	-	7	pF
LL3A; TTL MODE; FIG. 4						
$V_{IL}$	LOW level input voltage		0	-	0.8	V
$V_{IH}$	HIGH level input voltage		2.0	-	$V_{DD}$	V
$t_{CA}$	LL3A cycle time	note 10	69	74	80	ns
$t_{CAH}$	LL3A HIGH time		28	-	-	ns
$t_{CAL}$	LL3A LOW time		28	-	-	ns
$I_{LI}$	input leakage current	$V_I = 0$ to $V_{DD}$	-100	-	+100	$\mu A$
$C_I$	input capacitance	note 26	-	-	10	pF

## Multi-standard Teletext IC for standard and features TV

SAA9042

SYMBOL	PARAMETER	CONDITIONS	MIN.	TYP.	MAX.	UNIT
LL3A; AC MODE; F = 13.5 MHz; SEE FIG.4						
V <sub>ACM</sub>	mean voltage level	notes 25 and 26	-12	-	+12	V
V <sub>AC(p-p)</sub>	AC voltage (peak-to-peak value)		1.0	-	3.0	V
V <sub>ACH</sub>	voltage HIGH w.r.t. mean		0.3	-	2.0	V
V <sub>ACL</sub>	voltage LOW w.r.t. mean		-2.0	-	-0.3	V
msr	input mark/space ratio w.r.t. mean t <sub>ACH</sub> /t <sub>ACL</sub> or t <sub>ACL</sub> /t <sub>ACH</sub>	note 28	30 : 70	-	70 : 30	
C <sub>s</sub>	series capacitance		47	100	220	pF
Z <sub>i</sub>	input impedance	notes 24 and 26	10	-	-	kΩ
SCL; NOTE 31						
V <sub>IL</sub>	LOW level input voltage		0	-	1.5	V
V <sub>IH</sub>	HIGH level input voltage		3.0	-	V <sub>DD</sub>	V
t <sub>r</sub>	input rise time	notes 4 and 26	-	-	1	μs
t <sub>f</sub>	input fall time	notes 11 and 26	-	-	300	ns
I <sub>LI</sub>	input leakage current	note 12; V <sub>I</sub> = 0 to V <sub>DD</sub>	-10	-	+10	μA
C <sub>i</sub>	input capacitance	note 26	-	-	7	pF
HSD						
V <sub>IL</sub>	LOW level input voltage		0	-	0.8	V
V <sub>IH</sub>	HIGH level input voltage		2.0	-	V <sub>DD</sub>	V
t <sub>r</sub> , t <sub>f</sub>	input rise and fall times	notes 4 and 26	-	50	500	ns
I <sub>LI</sub>	input leakage current	V <sub>I</sub> = 0 to V <sub>DD</sub>	-10	-	+10	μA
C <sub>i</sub>	input capacitance	note 26	-	-	7	pF
VSD						
V <sub>IL</sub>	LOW level input voltage		0	-	0.8	V
V <sub>IH</sub>	HIGH level input voltage		2.0	-	V <sub>DD</sub>	V
t <sub>r</sub> , t <sub>f</sub>	input rise and fall times	notes 4 and 26	-	-	500	ns
I <sub>LI</sub>	input leakage current	V <sub>I</sub> = 0 to V <sub>DD</sub>	-10	-	+10	μA
C <sub>i</sub>	input capacitance	note 26	-	-	7	pF



## Multi-standard Teletext IC for standard and features TV

SAA9042

SYMBOL	PARAMETER	CONDITIONS	MIN.	TYP.	MAX.	UNIT
LL3D/LL1.5D; TTL MODE						
$V_{IL}$	LOW level input voltage		0	–	0.8	V
$V_{IH}$	HIGH level input voltage		2.0	–	$V_{DD}$	V
$t_r, t_f$	input rise and fall times	notes 4 and 26	–	–	10	ns
$t_{CA}$	LL3D/LL1.5D cycle time	13.5 MHz	69	74	80	ns
		27.0 MHz	35	37	40	ns
$t_{CAH}$	LL3D/LL1.5D HIGH time	13.5 MHz	28	–	–	ns
		27.0 MHz	14	–	–	ns
$t_{CAL}$	LL3D/LL1.5D LOW time	13.5 MHz	28	–	–	ns
		27.0 MHz	14	–	–	ns
$I_{LI}$	input leakage current	$V_I = 0$ to $V_{DD}$	–100	–	+100	$\mu$ A
$C_I$	input capacitance	note 26	–	–	10	pF
LL3D/LL1.5D; AC MODE; $f = 13.5$ MHz OR 27 MHz; SEE FIG.4						
$V_{ACM}$	mean voltage level	notes 25 and 26	–12	–	+12	V
$V_{AC(p-p)}$	AC voltage		1.0	–	3.0	V
$V_{ACH}$	voltage HIGH w.r.t. mean		0.3	–	2.0	V
$V_{ACL}$	voltage LOW w.r.t. mean		–2.0	–	–0.3	V
$msr$	input mark/space ratio w.r.t. mean $t_{ACH}/t_{ACL}$ OR $t_{ACL}/t_{ACH}$	note 28	30 : 70	–	70 : 30	
$C_s$	series capacitance		47	100	220	pF
$Z_i$	input impedance	notes 24 and 26	10	–	–	k $\Omega$
<b>Inputs/outputs; note 13</b>						
SDA; OPEN-DRAIN I/O; NOTE 31						
$V_{IL}$	LOW level input voltage		0	–	1.5	V
$V_{IH}$	HIGH level input voltage		3.0	–	$V_{DD}$	V
$t_r$	input rise time	notes 4 and 26	–	–	1	$\mu$ s
$t_f$	input fall time	notes 11 and 26	–	–	300	ns
$I_{LI}$	input leakage current	$V_I = 0$ to $V_{DD}$ ; note 12; with output off	–10	–	+10	$\mu$ A
$C_I$	input capacitance	note 26	–	–	7	pF
$V_{OL}$	LOW level output voltage	$I_{OL} = 3$ mA	0	–	0.4	V
$t_f$	output fall time	notes 11 and 26	–	–	300	ns
$C_L$	load capacitance		–	–	400	pF

## Multi-standard Teletext IC for standard and features TV

SAA9042

SYMBOL	PARAMETER	CONDITIONS	MIN.	TYP.	MAX.	UNIT
<b>D0/D4 to D3/D7</b>						
$V_{IL}$	LOW level input voltage		0	-	0.8	V
$V_{IH}$	HIGH level input voltage		2.0	-	$V_{DD}$	V
$I_{LI}$	input leakage current	note 12; $V_I = 0$ to $V_{DD}$ ; with output off	-10	-	+10	$\mu$ A
$C_I$	input capacitance	note 26	-	-	7	pF
$V_{OL}$	LOW level output voltage	$I_{OL} = 1.6$ mA	0	-	0.4	V
$V_{OH}$	HIGH level output voltage	$I_{OH} = -200$ $\mu$ A	2.4	-	$V_{DD}$	V
$t_r, t_f$	output rise and fall times between 0.6 V and 1.8 V	note 26	-	-	10	ns
$C_L$	load capacitance	note 21	-	-	100	pF
<b>Outputs; note 13</b>						
<b>SAND; NOTE 22</b>						
$V_{OL}$	LOW level output voltage	$I_{OL} = 0.2$ mA	0	-	0.3	V
$V_{OI}$	intermediate level output voltage	$I_{OI} = \pm 30$ $\mu$ A	1.3	-	2.7	V
$V_{OH}$	HIGH level output voltage	$I_{OH} = 0$ to $-10$ $\mu$ A	4.0	-	$V_{DD}$	V
$t_r$	output rise time $V_{OL}$ to $V_{OI}$ between 0.4 V and 1.1 V	note 26	-	-	400	ns
$t_r$	output rise time $V_{OL}$ to $V_{OH}$ between 2.9 V and 4.0 V	note 26	-	-	200	ns
$t_f$	output fall time $V_{OH}$ to $V_{OL}$ between 4.0 V and 0.4 V	note 26	-	-	50	ns
$C_L$	load capacitance		-	-	30	pF
<b>INT; OPEN-DRAIN OUTPUT</b>						
$V_{OL}$	LOW level output voltage	$I_{OL} = 1.6$ mA	0	-	0.4	V
$I_{LO}$	output leakage current	$V_{PU} = 0$ V to $V_{DD}$ ; with output off	-10	-	+10	$\mu$ A
$t_f$	output fall time	notes 15 and 26	-	-	50	ns
$C_L$	load capacitance		-	-	100	pF
<b>A0/A9 to A8/A17</b>						
$V_{OL}$	LOW level output voltage	$I_{OL} = 1.6$ mA	0	-	0.4	V
$V_{OH}$	HIGH level output voltage	$I_{OH} = -200$ $\mu$ A	2.4	-	$V_{DD}$	V
$t_r, t_f$	output rise and fall times between 0.6 V and 1.8 V	note 26	-	-	10	ns
$C_L$	load capacitance	note 23	-	-	100	pF

## Multi-standard Teletext IC for standard and features TV

SAA9042

SYMBOL	PARAMETER	CONDITIONS	MIN.	TYP.	MAX.	UNIT
RAS, CAS AND R/W						
$V_{OL}$	LOW level output voltage	$I_{OL} = 1.6 \text{ mA}$	0	-	0.4	V
$V_{OH}$	HIGH level output voltage	$I_{OH} = -200 \text{ } \mu\text{A}$	2.4	-	$V_{DD}$	V
$t_r, t_f$	output rise and fall times between 0.6 V and 1.8 V	note 26	-	-	10	ns
$C_L$	load capacitance	note 23	-	-	100	pF
DISP PL AND FRAME						
$V_{OL}$	LOW level output voltage	$I_{OL} = 1.6 \text{ mA}$	0	-	0.4	V
$V_{OH}$	HIGH level output voltage	$I_{OH} = -200 \text{ } \mu\text{A}$	2.4	-	$V_{DD}$	V
$t_r, t_f$	output rise and fall times	notes 16 and 26	-	-	200	ns
$C_L$	load capacitance		-	-	200	pF
R, G, B; 3-STATE; NOTE 29						
$V_{OL}$	LOW level output voltage	$I_{OL} = 2.0 \text{ mA}$ ; note 17	$V_{SS0}$	-	$V_{SS0} + 0.2$	V
$V_{OH}$	HIGH level output voltage	$I_{OH} = -2 \text{ mA}$ ; note 18	-	note 30	-	V
$t_r, t_f$	output rise and fall times between 0.6 V and 1.8 V	notes 4, 17 and 26	-	-	10	ns
$C_L$	load capacitance		-	-	30	pF
$C_{off}$	output capacitance	off state; note 26	-	-	10	pF
$I_{off}$	output leakage current	off state; $V_I = 0 \text{ to } V_{DD}$	-10	-	+10	$\mu\text{A}$
VDS; 3-STATE; NOTE 29						
$V_{OL}$	LOW level output voltage	$I_{OL} = 1.0 \text{ mA}$	0	-	0.2	V
$V_{OH}$	HIGH level output voltage	$I_{OH} = -200 \text{ } \mu\text{A}$	1.1	-	2.8	V
$t_r, t_f$	output rise and fall times	note 26	-	-	10	ns
$C_L$	load capacitance		-	-	30	pF
$I_{off}$	output leakage current	off state; $V_I = 0 \text{ to } V_{DD}$	-10	-	+10	$\mu\text{A}$
$t_{skew}$	skew delay between R, G, B and VDS outputs	note 19	-	-	10	ns

Multi-standard Teletext IC for standard and features TV

SAA9042

SYMBOL	PARAMETER	CONDITIONS	MIN.	TYP.	MAX.	UNIT
<b>Timing</b>						
I <sup>2</sup> C-BUS; NOTE 20; FIG.3						
f <sub>SCL</sub>	SCL clock frequency	note 31	0	-	100	kHz
t <sub>LOW</sub>	clock LOW period		4	-	-	μs
t <sub>HIGH</sub>	clock HIGH period		4	-	-	μs
t <sub>SU;DAT</sub>	data set-up time		250	-	-	ns
t <sub>HD;DAT</sub>	data hold time		0	-	-	ns
t <sub>SU;STO</sub>	set-up time from clock HIGH to STOP		4	-	-	μs
t <sub>BUF</sub>	START set-up time following a STOP		4	-	-	μs
t <sub>HD;STA</sub>	START hold time		4	-	-	μs
t <sub>SU;STA</sub>	START set-up time following clock LOW-to-HIGH transition		4	-	-	μs
MEMORY INTERFACE; NOTE 14; FIGS 5 AND 6						
t <sub>CY</sub>	cycle time		-	481	-	ns
t <sub>T</sub>	transition time		-	-	10	ns
t <sub>W;RAS</sub>	RAS pulse width		120	-	-	ns
t <sub>PC;RAS</sub>	RAS precharge time		90	-	-	ns
t <sub>HD;CAS</sub>	CAS hold time		120	-	-	ns
t <sub>CY;PM</sub>	page mode cycle time		120	-	-	ns
t <sub>d</sub>	RAS to CAS delay time		25	-	-	ns
t <sub>W;CAS</sub>	CAS pulse width		60	-	-	ns
t <sub>PC;CAS</sub>	CAS precharge time		50	-	-	ns
t <sub>SU;ROW</sub>	row address set-up time		0	-	-	ns
t <sub>HD;ROW</sub>	row address hold time		15	-	-	ns
t <sub>SU;COL</sub>	column address set-up time		0	-	-	ns
t <sub>HD;COL</sub>	column address hold time		20	-	-	ns
t <sub>SU;RD</sub>	read command set-up time		0	-	-	ns
t <sub>HD;RDC</sub>	read command hold time referenced to CAS		0	-	-	ns
t <sub>HD;RDR</sub>	read command hold time referenced to RAS		10	-	-	ns
t <sub>ACC;CAS</sub>	access time from CAS		-	-	60	ns
t <sub>W;WR</sub>	write command pulse width		50	-	-	ns
t <sub>HD;WR</sub>	write command hold time		40	-	-	ns
t <sub>SU;DAT1</sub>	data input set-up time		0	-	-	ns
t <sub>HD;DAT1</sub>	data input hold time		40	-	-	ns

# Multi-standard Teletext IC for standard and features TV

SAA9042

SYMBOL	PARAMETER	CONDITIONS	MIN.	TYP.	MAX.	UNIT
$t_{ACC,RAS}$	access time from $\overline{RAS}$		–	–	120	ns
$t_{HD,RC}$	$\overline{RAS}$ hold time after $\overline{CAS}$		60	–	–	ns
$t_{PC,CR}$	$\overline{CAS}$ to $\overline{RAS}$ precharge time		20	–	–	ns
$t_{HD,COLR}$	column address hold time referenced to $\overline{RAS}$		80	–	–	ns
$t_{HD,DATIR}$	data input hold time referenced to $\overline{RAS}$		100	–	–	ns

## Notes

- The rise time of  $V_{DD}$  from 0 to 4.5 V must be >150 ns to ensure that the internal power-on reset triggers. For this circuit to reset the chip,  $V_{DD}$  must be initially <1.0 V or fall to <1.0 V for at least 100 ns. Spikes on  $V_{DD}$  are tolerable provided that  $V_{DD}$  is not reduced to <2.5 V.
- All inputs are protected against static charge under normal handling.
- The TTD input incorporates an internal clamping diode in addition to the active clamping transistor.
- Rise and fall times are measured between 10% and 90% levels.
- Teletext input data set-up and hold times are measured with respect to 50% duty factor level of the rising edge of the teletext clock input (TTC). Data stable 1  $\geq$  2.0 V, data stable 0  $\leq$  0.8 V.
- Clamp times measured from the line sync reference point, assuming acquisition timing is set correctly.
- Clamping transistor on,  $V_{TTD} - V_{SS1} \leq 0.1$  V.
- The TTC input has an internal clamping diode.
- $\overline{HSA}$  is falling edge triggered.
- Minimum and maximum cycle times are  $\pm 7.1\%$  of the typical value.
- Fall time is measured between 3.0 V and 1.5 V.
- Applies even when  $V_{DD} = 0$  V.
- All input/outputs and outputs are protected against static charge under normal handling.
- For details of memory interface timings to and from external DRAM see Figs 5 and 6.
- Output fall time measured between 4.0 V and 1.0 V levels with a 3.3 k $\Omega$  load to 5.0 V.
- Output rise and fall times measured between 0.8 V and 2.0 V levels.
- Measured with  $I_{OL} = 2.0$  mA,  $V_{SS0} = V_{SS1/2/3}$  and output voltage ( $C_{DAC}$ ) = 1.5 V.
- Measured with  $I_{OH} = -2$  mA,  $V_{SS0} = V_{SS1/2/3}$  and output voltage ( $C_{DAC}$ ) = 0.5 to 1.5 V.
- Skew delay time measured at 0.7 V levels.
- For details of I<sup>2</sup>C-bus timings see Fig.3; timings are referenced to  $V_{IH} = 3.0$  V and  $V_{IL} = 1.5$  V.
- Load capacitance measured with two DRAM data inputs; 50 pF maximum.
- A current of 1  $\mu$ A flows out of the SAA5191 while its SAND input is in the range of 1 V to 3.5 V.
- Load capacitance measured with eight DRAM data inputs; 80 pF maximum.
- Through a 200 pF capacitor with a 13.5 MHz sinewave.
- To be applied via a series capacitor only.
- This specification point is included because of its importance to the application environment; it is not however guaranteed.
- When connected to the SAA5191, it is acceptable for the clock frequency to initially attain  $\leq 15$  MHz in order to achieve synchronization.

Multi-standard Teletext IC for standard and features TV

SAA9042

- 28. When connected to the SAA5191, it is acceptable for the input voltage to attain  $V_{DD} + 0.9$  V. The input current must be restricted as specified in the limiting values.
- 29. These outputs can be made 3-state via the I<sup>2</sup>C-bus.
- 30. Typical values adjustable over 0.5 to 1.5 V via the I<sup>2</sup>C-bus.
- 31. A standard (100 kHz) I<sup>2</sup>C interface is implemented. Fast mode (400 kHz) is not supported.

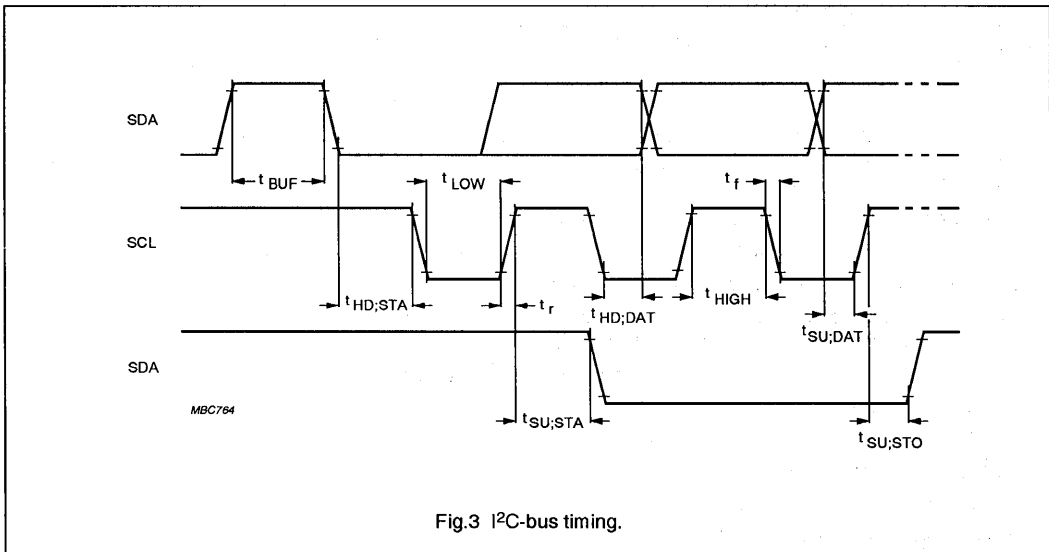

Fig.3 I<sup>2</sup>C-bus timing.

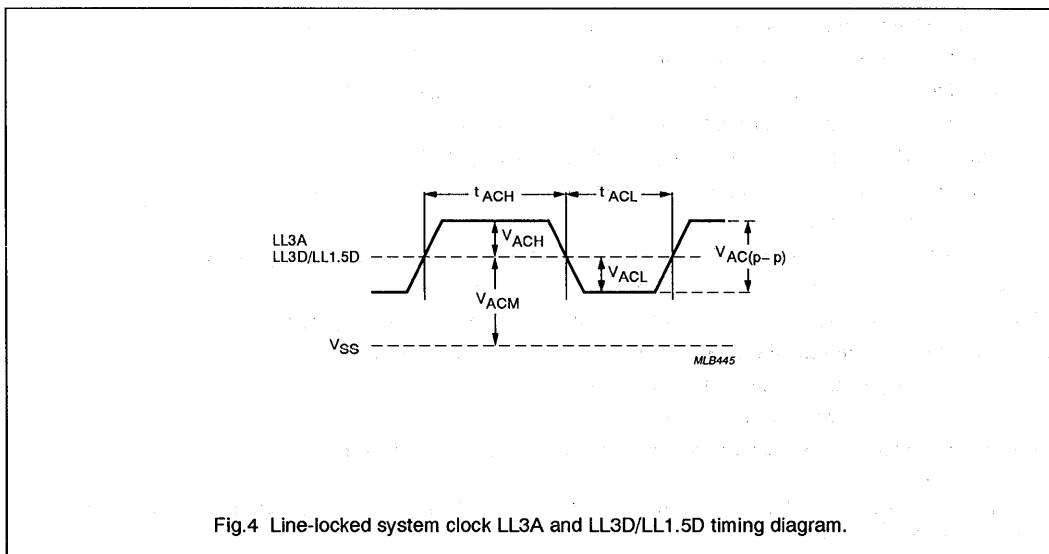

Fig.4 Line-locked system clock LL3A and LL3D/LL1.5D timing diagram.

Multi-standard Teletext IC for standard and features TV

SAA9042

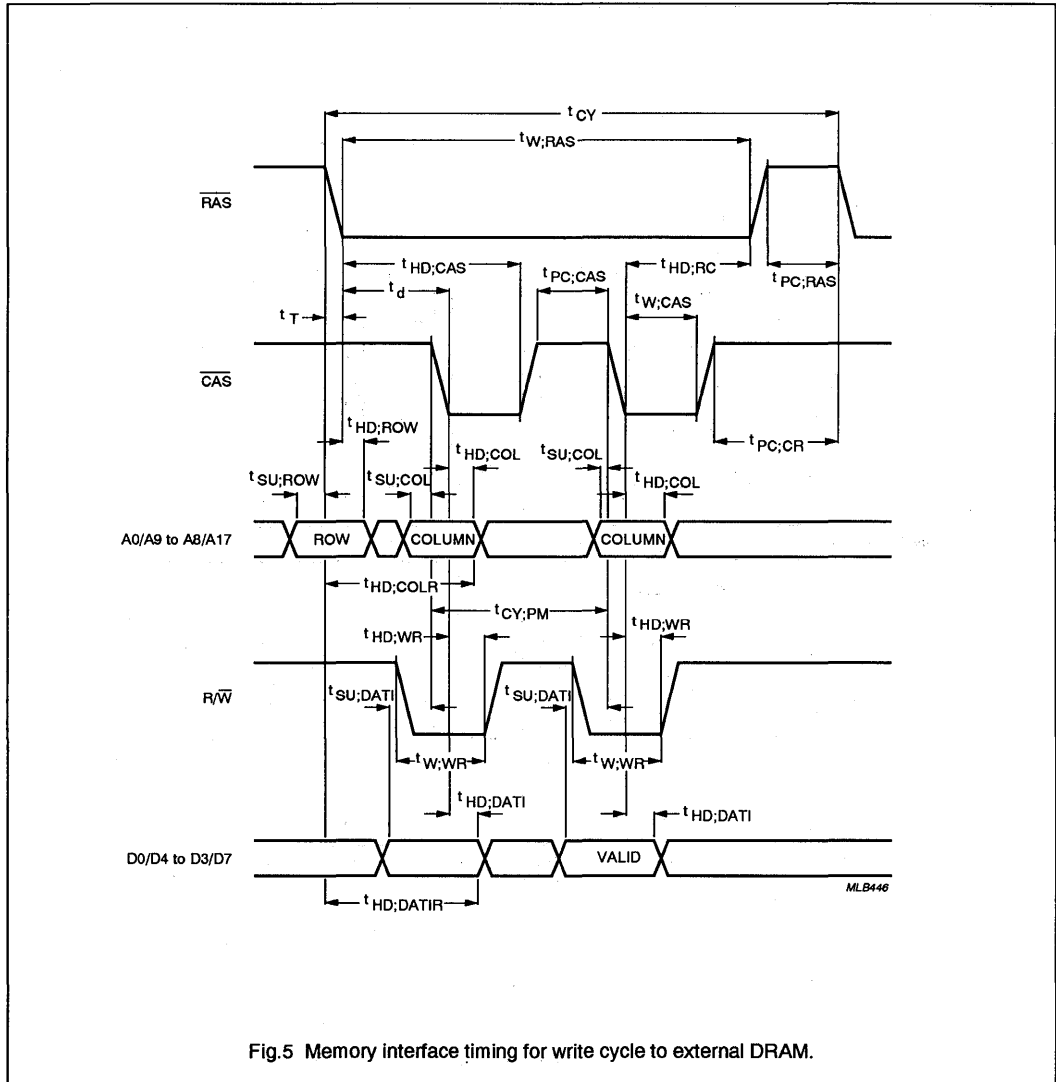

Fig.5 Memory interface timing for write cycle to external DRAM.





Multi-standard Teletext IC for standard and features TV

SAA9042

Table 1 SAA9042A West European character set; for N.O. (national option character position) see Table 2.

BITS	b <sub>7</sub> →				b <sub>6</sub> →				b <sub>5</sub> →				b <sub>4</sub> →				column	row	description	graphics
	b <sub>3</sub>	b <sub>2</sub>	b <sub>1</sub>	b <sub>0</sub>	b <sub>3</sub>	b <sub>2</sub>	b <sub>1</sub>	b <sub>0</sub>	b <sub>3</sub>	b <sub>2</sub>	b <sub>1</sub>	b <sub>0</sub>	b <sub>3</sub>	b <sub>2</sub>	b <sub>1</sub>	b <sub>0</sub>				
0 0 0 0	0	0	0	0	0	0	0	0	0	0	0	0	0	0	0	0	0	0	alpha- numerics black	graphics black
0 0 0 1	0	0	0	1	0	0	0	1	0	0	0	1	0	0	0	1	1	1	alpha- numerics red	graphics red
0 0 1 0	0	0	1	0	0	0	1	0	0	0	1	0	0	0	1	0	2	2a	alpha- numerics green	graphics green
0 0 1 1	0	0	1	1	0	0	1	1	0	0	1	1	0	0	1	1	3	3a	alpha- numerics yellow	graphics yellow
0 1 0 0	0	1	0	0	0	1	0	0	0	1	0	0	0	1	0	0	4	4a	alpha- numerics blue	graphics blue
0 1 0 1	0	1	0	1	0	1	0	1	0	1	0	1	0	1	0	1	5	5a	alpha- numerics magenta	graphics magenta
0 1 1 0	0	1	1	0	0	1	1	0	0	1	1	0	0	1	1	0	6	6a	alpha- numerics cyan	graphics cyan
0 1 1 1	0	1	1	1	0	1	1	1	0	1	1	1	0	1	1	1	7	7a	alpha- numerics white <sup>(2)</sup>	graphics white <sup>(2)</sup>
1 0 0 0	1	0	0	0	1	0	0	0	1	0	0	0	1	0	0	0	8	8a	flash	conceal display
1 0 0 1	1	0	0	1	1	0	0	1	1	0	0	1	1	0	0	1	9	9a	steady <sup>(2)</sup>	contiguous graphics <sup>(2)</sup>
1 0 1 0	1	0	1	0	1	0	1	0	1	0	1	0	1	0	1	0	10	10a	end box <sup>(2)</sup>	separated graphics <sup>(2)</sup>
1 0 1 1	1	0	1	1	1	0	1	1	1	0	1	1	1	0	1	1	11	11a	start box	ESC <sup>(1)</sup>
1 1 0 0	1	1	0	0	1	1	0	0	1	1	0	0	1	1	0	0	12	12a	normal height <sup>(2)</sup>	black back-ground <sup>(2)</sup>
1 1 0 1	1	1	0	1	1	1	0	1	1	1	0	1	1	1	0	1	13	13a	double height	new back-ground
1 1 1 0	1	1	1	0	1	1	1	0	1	1	1	0	1	1	1	0	14	14a	double width	hold graphics
1 1 1 1	1	1	1	1	1	1	1	1	1	1	1	1	1	1	1	1	15	15a	double size	release graphics <sup>(2)</sup>

MLB446

# Multi-standard Teletext IC for standard and features TV

SAA9042

**Notes to Table 1**

1. These control characters are reserved for compatibility with other data codes.
2. These control characters are presumed before each rows begins.

**Table 2** SAA9042A West European national option sets.

LANGUAGE	PHCB <sup>(1)</sup>			CHARACTER POSITION (COLUMN / ROW)													
	C12	C13	C14	2/3	2/4	4/0	5/11	5/12	5/13	5/14	5/15	6/0	7/11	7/12	7/13	7/14	
ENGLISH	0	0	0	£	\$	@	←	↳	→	↑	#	—	¼	½	¾	÷	
GERMAN	0	0	1	#	\$	§	Ä	Ö	Ü	^	□	°	ä	ö	ü	ß	
SWEDISH	0	1	0	#	×	é	Ä	Ö	Å	Ü	□	é	ä	ö	å	ü	
ITALIAN <sup>(2)</sup>	0	1	1	£	\$	é	°	ç	→	↑	#	ù	à	ò	è	ì	
FRENCH	1	0	0	é	ï	à	ë	è	ù	î	#	è	à	ò	ù	ç	
SPANISH	1	0	1	ç	\$	i	á	é	í	ó	ú	¿	ü	ñ	è	à	

MEA559

**Notes**

1. Where PHCB are the Page Header Control Bits. Other combinations of PHCB default to English.
2. Basic character set is Italian. Selected when the force language bit (D5) in the display set-up register (R12) is set to logic 1.

Multi-standard Teletext IC for standard and features TV

SAA9042

Table 3 SAA9042B Eastern European character set; for N.O. (national option character position) see Table 4.

BITS		b <sub>7</sub>	b <sub>6</sub>	b <sub>5</sub>	b <sub>4</sub>	b <sub>3</sub>	b <sub>2</sub>	b <sub>1</sub>	b <sub>0</sub>	column	0	1	2	2a	3	3a	4	5	6	6a	7	7a	8	9	10	11	12	13	14	15
0	0	0	0	0	0	0	0	0	0	0	alpha- numerics black	graphics black			0		N.O.	P	N.O.		p		ñ	ç		0	\$	½	×	ü
0	0	0	1							1	alpha- numerics red	graphics red	!	□	1		A	Q	a		q		ö	ü	!	1	E	A	Z	ä
0	0	1	0							2	alpha- numerics green	graphics green	"	□	2		B	R	b		r		á	ç	"	2	S	ç	E	ö
0	0	1	1							3	alpha- numerics yellow	graphics yellow	N.O.	□	3		C	S	c		s		z	ç	§	3	Ä	Ç	Ä	I
0	1	0	0							4	alpha- numerics blue	graphics blue	N.O.	□	4		D	T	d		t		š	ž	ı	4	ö	ž	ö	č
0	1	0	1							5	alpha- numerics magenta	graphics magenta	%	□	5		E	U	e		u		ž	ý	%	5	ü	ö	Ä	I
0	1	1	0							6	alpha- numerics cyan	graphics cyan	&	□	6		F	V	f		v		č	ı	&	6	^	š	ü	č
0	1	1	1							7	alpha- numerics white <sup>(2)</sup>	graphics white	'	□	7		G	W	g		w		ó	ř	'	7		ě		N
1	0	0	0							8	flash	conceal display	(	□	8		H	X	h		x		é	é	(	8	°	č	é	ň
1	0	0	1							9	steady <sup>(2)</sup>	contiguous graphics <sup>(2)</sup>	)	□	9		I	Y	i		y		ž	á	)	9	ä	č	ä	N
1	0	1	0							10	end box <sup>(2)</sup>	separated graphics	*	□	:		J	Z	j		z		š	ě	*	:	ö	ž	ö	ř
1	0	1	1							11	start box	ESC <sup>(1)</sup>	+	□	:		K	N.O.	k		N.O.		ž	ü	+	:	ü	ä	Ä	R
1	1	0	0							12	normal height <sup>(2)</sup>	black back-ground <sup>(2)</sup>	,	□	<		L	N.O.	l		N.O.		ž	š	,	<	ß	š	ü	ř
1	1	0	1							13	double height	new back-ground	-	□	=		M	N.O.	m		N.O.		é	é	-	=	Ä	ö	ö	ř
1	1	1	0							14	double width	hold graphics	.	□	>		N	N.O.	n		N.O.		ö	ö	.	>	é	ö	ö	ř
1	1	1	1							15	double size <sup>(2)</sup>	release graphics	/	□	?		O	N.O.	o				ö	ö	/	?	ı	ü	ü	é

MLB446

# Multi-standard Teletext IC for standard and features TV

SAA9042

### Notes to Table 3

1. These control characters are reserved for compatibility with other data codes.
2. These control characters are presumed before each rows begins.

**Table 4** SAA9042B Eastern European national option sets.

LANGUAGE	PHCB <sup>(1)</sup>			CHARACTER POSITION (COLUMN / ROW)												
	C12	C13	C14	2/3	2/4	4/0	5/11	5/12	5/13	5/14	5/15	6/0	7/11	7/12	7/13	7/14
POLISH	0	0	0	#	ń	ą	ż	ś	ł	ć	ó	ę	ź	ś	ź	ź
GERMAN	0	0	1	#	ß	š	ä	ö	ü	^	_	°	ä	ö	ü	ß
SWEDISH	0	1	0	#	å	é	ä	ö	å	ü	_	é	ä	ö	å	ü
SERBO-CROAT	1	0	1	#	₂	č	ć	ž	đ	š	ě	č	ć	ž	đ	š
CZECHOSLOVAK	1	1	0	#	š	č	ř	ž	ý	í	ř	ě	á	ě	ú	š
ROMANIAN <sup>(2)</sup>	1	1	1	#	ş	ţ	ă	ş	ă	ţ	ı	ţ	ă	ş	ă	ţ

*MLB450*

### Notes

1. Other combinations of C12, C13 and C14 default to German.
2. Basic character set is Romanian. Selected when the force language bit (D5) in the display set-up register (R12) is set to logic 1.

Multi-standard Teletext IC for standard and features TV

SAA9042

Table 5 SAA9042C Euro-Turkish character set; for N.O. (national option character position) see Table 6.

BITS	b <sub>7</sub> →				b <sub>6</sub> →				b <sub>5</sub> →				b <sub>4</sub> →				b <sub>3</sub> →				b <sub>2</sub> →				b <sub>1</sub> →				b <sub>0</sub> →						
	0	0	0	0	0	0	0	0	0	1	0	0	0	1	0	0	0	1	0	0	0	1	0	0	1	1	1	1	1	1	1	1	1	1	1
column	0	1	2	2a	3	3a	4	5	6	6a	7	7a	8	9	10	11	12	13	14	15															
0 0 0 0	0	alpha - numerics black	graphics black		0		N.O.	P	N.O.		p		\$	ö		0	\$	\$	i	Á															
0 0 0 1	1	alpha - numerics red	graphics red	!	1	A	Q	a		q			£	l	!	1	#	ç	é	Á															
0 0 1 0	2	alpha - numerics green	graphics green	"	2	B	R	b		r			@	i	"	2	§	i	á	É															
0 0 1 1	3	alpha - numerics yellow	graphics yellow	N.O.	3	C	S	c		s			←	§	ö	3	Á	á	ë	†															
0 1 0 0	4	alpha - numerics blue	graphics blue	N.O.	4	D	T	d		t			½	ö	i	4	ö	ë	ë	‡															
0 1 0 1	5	alpha - numerics magenta	graphics magenta	%	5	E	U	e		u			→	ç	%	5	ü	i	ü	ó															
0 1 1 0	6	alpha - numerics cyan	graphics cyan	&	6	F	V	f		v			↑	ü	&	6	^	ö	i	ó															
0 1 1 1	7	alpha - numerics white <sup>(2)</sup>	graphics white	'	7	G	W	g		w			#	ç	'	7	_	ü	#	ü															
1 0 0 0	8	flash	conceal display	(	8	H	X	h		x			—	i	(	8	°	ö	é	‡															
1 0 0 1	9	steady <sup>(2)</sup>	contiguous graphics <sup>(2)</sup>	)	9	I	Y	i		y			¼	§	)	9	ä	ü	ä	ü															
1 0 1 0	10	end box <sup>(2)</sup>	separated graphics	*	:	J	Z	j		z				ö	*	:	ö	ñ	ö	↓															
1 0 1 1	11	start box	ESC <sup>(1)</sup>	+	:	K	N.O.	k		N.O.			¾	ç	+	:	ü	é	ö	É															
1 1 0 0	12	normal height <sup>(2)</sup>	black back-ground <sup>(2)</sup>	,	<	L	N.O.	l		N.O.			÷	ü	,	<	ß	á	ç	á															
1 1 0 1	13	double height	new back-ground	-	=	M	N.O.	m		N.O.			€	≡	-	=	ä	ß	p	ó															
1 1 1 0	14	double width	hold graphics	.	ˆ	N	N.O.	n		N.O.			⊗	⊗	.	ˆ	ö	ö	⊗	Á															
1 1 1 1	15	double size <sup>(2)</sup>	release graphics	/	?	o	N.O.	o					⊗	⊗	/	?	.	Á	N	‡															

MLB451

# Multi-standard Teletext IC for standard and features TV

SAA9042

**Notes to Table 5**

1. These control characters are reserved for compatibility with other data codes.
2. These control characters are presumed before each rows begins.

**Table 6** SAA9042C Euro-Turkish national option sets.

LANGUAGE	PHCB <sup>(1)</sup>			CHARACTER POSITION (COLUMN / ROW)													
	C12	C13	C14	2/3	2/4	4/0	5/11	5/12	5/13	5/14	5/15	6/0	7/11	7/12	7/13	7/14	
ENGLISH	0	0	0	£	\$	@	←	½	→	↑	#	—	¼		¾	÷	
GERMAN	0	0	1	#	\$	S	Ä	Ö	Ü	^	_	°	ä	ö	ü	ß	
ITALIAN <sup>(2)</sup>	0	1	1	£	\$	é	°	ç	→	↑	#	ù	à	ò	è	ì	
FRENCH	1	0	0	é	ï	à	ë	è	ù	î	#	è	ä	ö	ü	ç	
SPANISH	1	0	1	ç	\$	í	á	é	í	ó	ú	ó	ü	ñ	è	à	
TURKISH	1	1	0	İ	Ş	İ	Ş	Ö	Ç	Ü	Ğ	ı	Ş	ö	ç	ü	

MLB452

**Notes**

1. Other combinations of C12, C13 and C14 default to English.
2. Basic character set is Italian. Selected when the force language bit (D5) in the display set-up register (R12) is set to logic 1.

# Multi-standard Teletext IC for standard and features TV

SAA9042

## APPLICATION INFORMATION

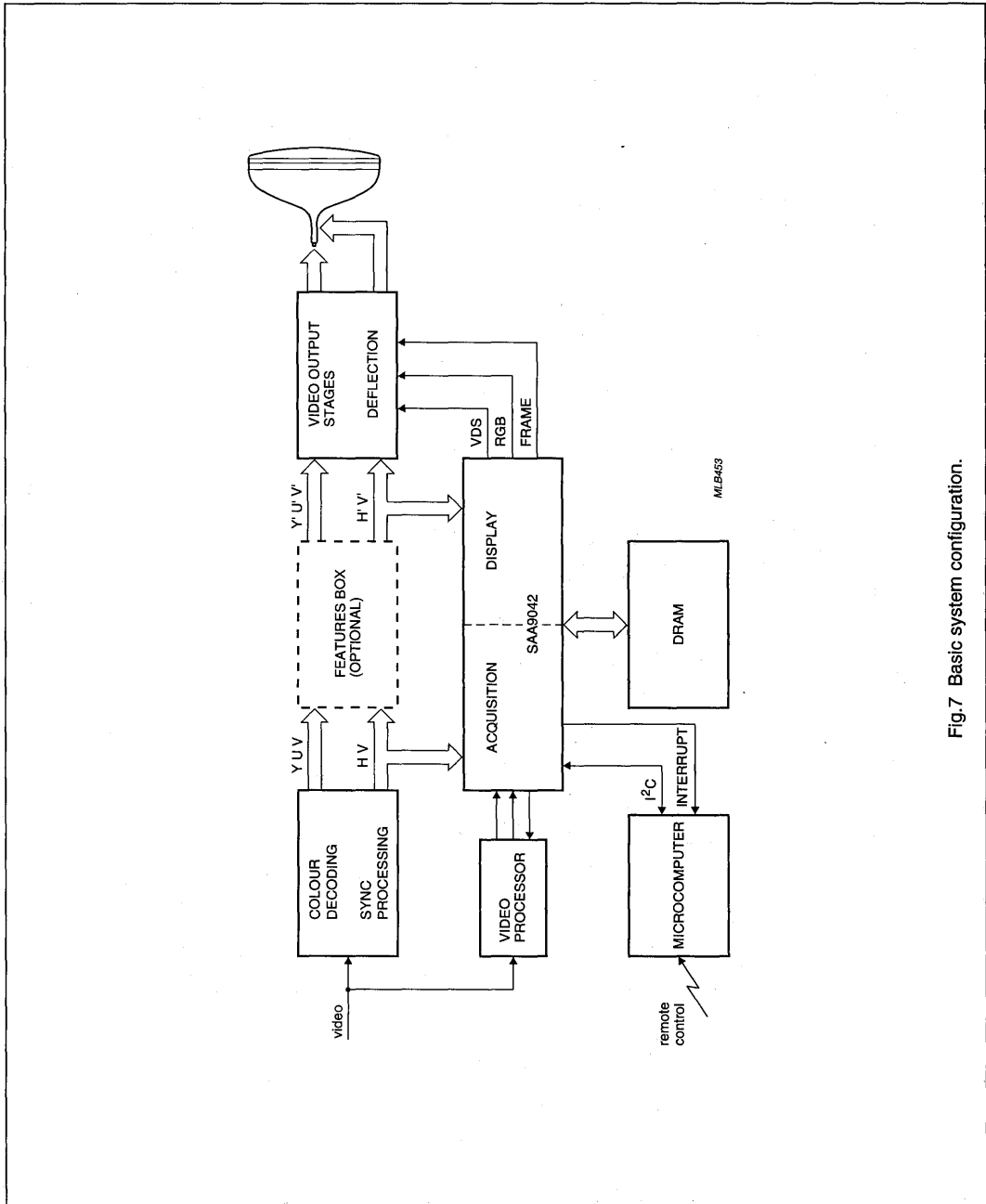

Fig.7 Basic system configuration.

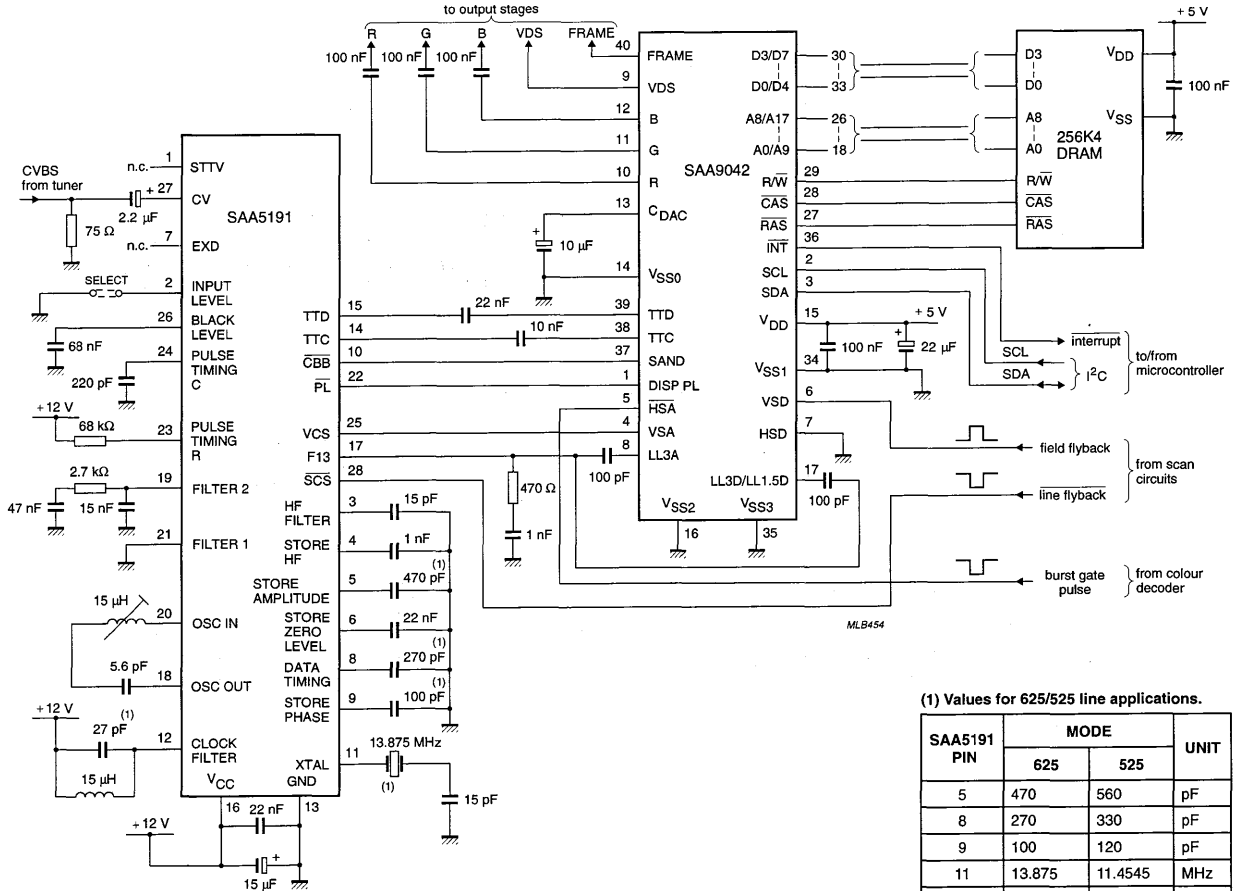

Fig.8 SAA9042 solution for 50/60 Hz analog TV (1H/1V) - scan sync mode.

(1) Values for 625/525 line applications.

SAA5191 PIN	MODE		UNIT
	625	525	
5	470	560	pF
8	270	330	pF
9	100	120	pF
11	13.875	11.4545	MHz
12	27	39	pF

Multi-standard Teletext IC for standard and features TV

SAA9042





Multi-standard Teletext IC for standard and features TV

SAA9042

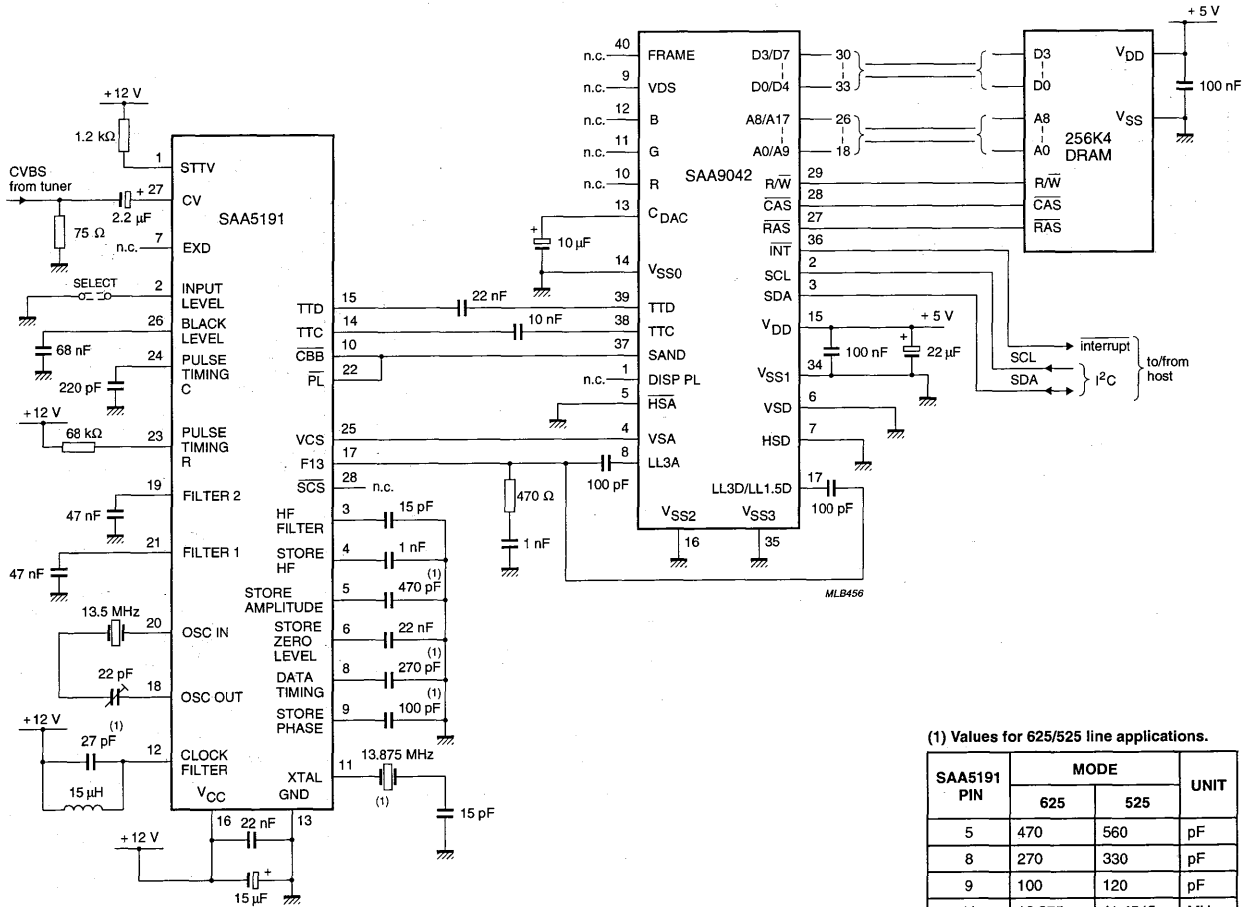

Fig.10 SAA9042 solution for multi-media applications.

# Digital multistandard TV decoder

# SAA9051

## FEATURES

- All operations based on a sampling frequency of 13.5 MHz, providing:
  - full adaptability to all transmission standards
  - capability for memory-based features
- Separate chrominance and luminance input (Y/C)
- CVBS input for standard applications
- CVBS throughput capability for SECAM application
- Luminance signal processing for all TV standards (PAL, NTSC, SECAM, B/W)
- Horizontal and vertical synchronization detection for all standards
- Chrominance signal processing for all quadrature amplitude modulated colour-carrier signals
- Requires only one crystal
- Controlled via the I<sup>2</sup>C-bus
- User-programmable aperture correction (horizontal peaking)
- Compatible with memory-based features (line-locked clock)
- Cross-colour reduction by chrominance comb-filter (NTSC)
- Wide range hue control

## GENERAL DESCRIPTION

The SAA9051 digital multistandard decoder (S-DMSD) performs demodulation and decoding of all quadrature modulated colour TV standards, as well as performing luminance processing for all TV standards with CVBS or Y/C input signals.

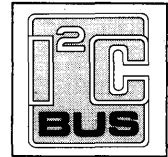

## ORDERING INFORMATION

EXTENDED TYPE NUMBER	PACKAGE			
	PINS	PIN POSITION	MATERIAL	CODE
SAA9051	68	PLCC	plastic	SOT188AGA, CG

Digital multistandard TV decoder

SAA9051

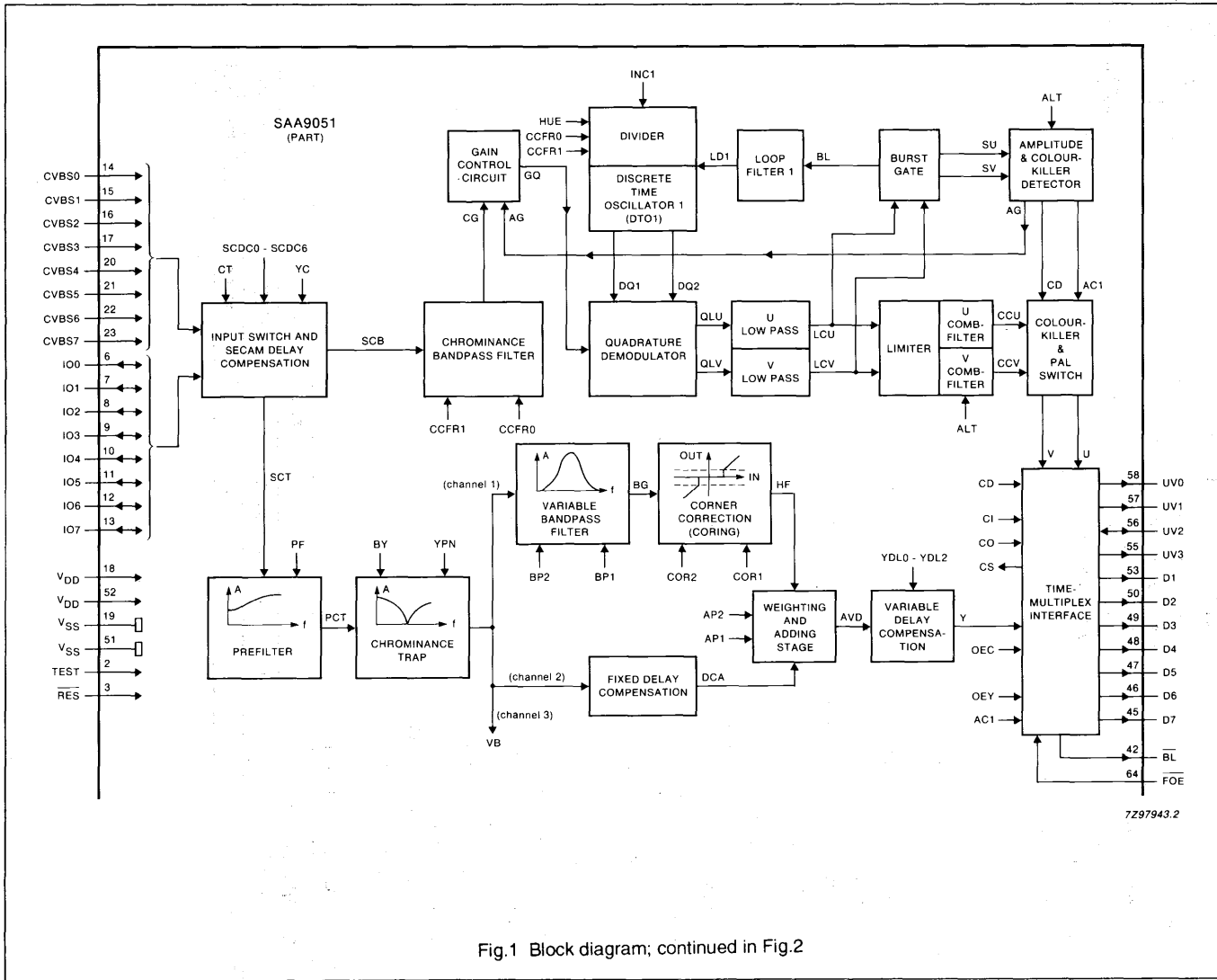

7297943.2

Fig.1 Block diagram; continued in Fig.2



Digital multistandard TV decoder

SAA9051

PIN CONFIGURATION

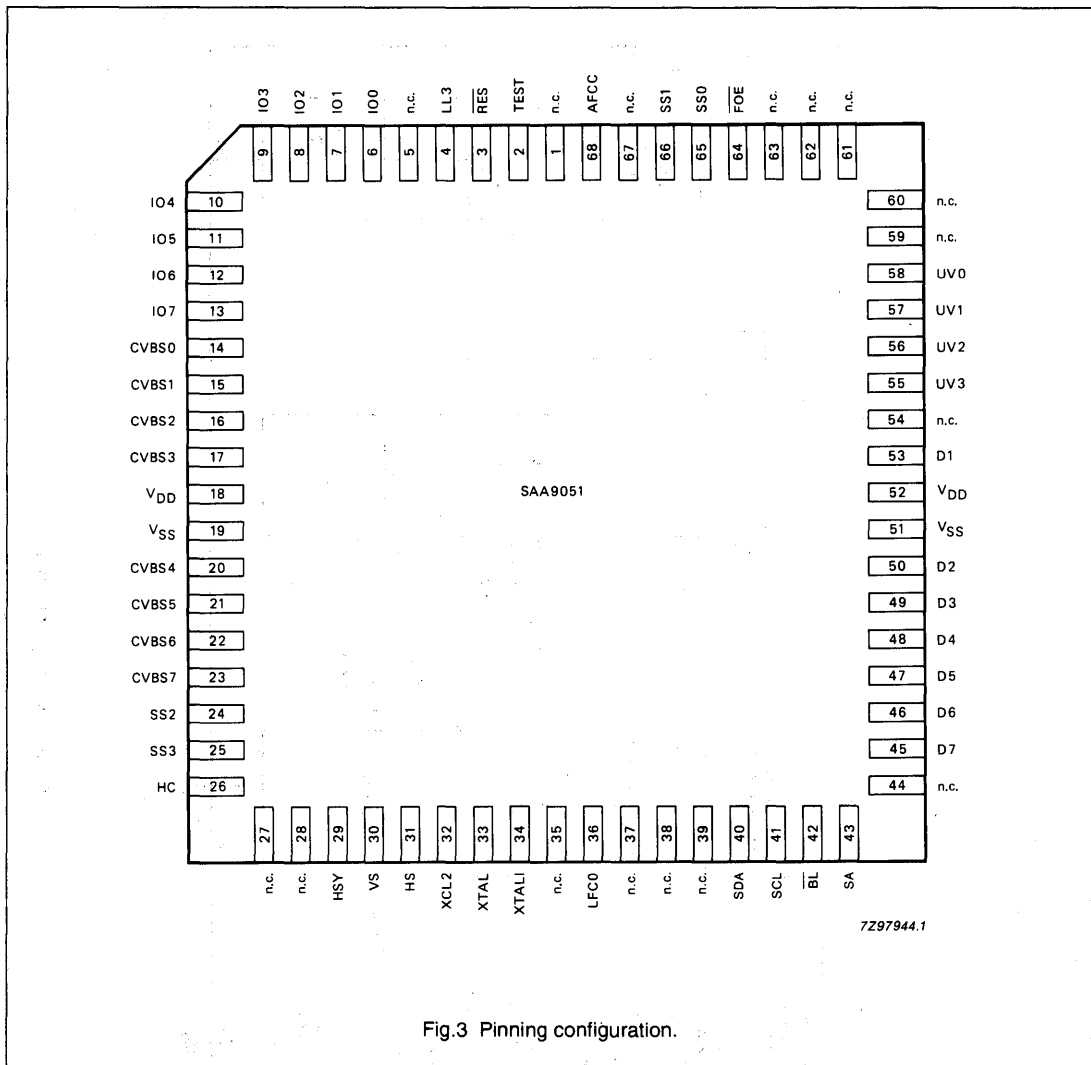

Fig.3 Pinning configuration.

## Digital multistandard TV decoder

SAA9051

## PINNING

SYMBOL	PIN	DESCRIPTION
n.c.	1	not connected
TEST	2	test input (active HIGH); when HIGH enables scan-test mode, always connected to ground
RES	3	reset input (active LOW); results in the I <sup>2</sup> C-bus control registers 1 to 3 and internal stages being reset during the reset phase. The minimum LOW period of RES is 120 LL3 clock cycles
LL3	4	13.5 MHz line-locked system clock
n.c.	5	not connected
IO0 (LSB) - IO7 (MSB)	6 - 13	bidirectional data path; chrominance input for separate luminance and chrominance input (Y/C) or CVBS output for SECAM decoder SAA9056. Two's complement format (IO0 is only used internally for CVBS throughput)
CVBS0 (LSB) - CVBS7 (MSB)	14 - 17, 20 - 23	digitalized composite video blanking and synchronization signals; containing luminance, chrominance and all synchronization information or luminance, blanking and synchronization signals in the event of separate luminance and chrominance (Y/C) input. Two's complement format (CVBS0 is only used internally for CVBS throughput)
V <sub>DD</sub>	18	positive supply voltage (+5 V)
V <sub>SS</sub>	19	ground (0 V)
SS2 - SS3	24 - 25	source select output signals; I <sup>2</sup> C-bus controlled, TTL compatible switches
HC	26	programmable horizontal output pulse; when used in conjunction with input circuits (e.g. ADC) indicates the black-level position before analog-to-digital conversion. The start and stop times are programmable, between -9.4 μs and +9.5 μs in steps of 74 ns, via the I <sup>2</sup> C-bus
n.c.	27 - 28	not connected
HSY	29	programmable horizontal output pulse; when used in conjunction with input circuits (e.g. an ADC). It indicates the synchronization pulse position before analog-to-digital conversion. The start and stop times are programmable, between -14.2 μs and +4.7 μs in steps of 74 ns, via the I <sup>2</sup> C-bus
VS	30	vertical synchronization output; indicates the vertical position of the picture for 50/60 Hz field frequency

## Digital multistandard TV decoder

SAA9051

## PINNING (continued)

SYMBOL	PIN	DESCRIPTION
HS	31	horizontal synchronization pulse output (duration = 64 LL3 clock cycles). HS is programmable, between $-32 \mu\text{s}$ and $+32 \mu\text{s}$ in steps of 300 ns, via the I <sup>2</sup> C-bus
XCL2	32	clock output; half of the crystal clock frequency (12.288 MHz). In phase with crystal (pin 33)
XTAL	33	crystal oscillator input/inverting amplifier output; input to the internal clock generator from an external oscillator or output of the inverting amplifier to an external crystal (24.576 MHz)
XTALI	34	input to the inverting amplifier from an external crystal (24.576 MHz); connect to ground if an external oscillator is used
n.c.	35	not connected
LFCO	36	line frequency control; analog output representing a multiple of the line frequency (6.75 MHz) with 4-bit resolution, the phase of which is compared to the system clock by the CGC (SAA9057A)
n.c.	37 - 39	not connected
SDA	40	I <sup>2</sup> C-bus serial data input/output
SCL	41	I <sup>2</sup> C-bus serial clock input
$\overline{\text{BL}}$	42	blanking signal output (active LOW); indicates the active video and line blanking periods. $\overline{\text{BL}}$ also synchronizes the data multiplexers/demultiplexers
SA	43	I <sup>2</sup> C-bus select address; input for selection of the appropriate I <sup>2</sup> C-bus slave address
D7 (MSB) - D1 (LSB)	45 - 50, 53	luminance data output
V <sub>SS</sub>	51	ground (0 V)
V <sub>DD</sub>	52	positive supply voltage (+5 V)
n.c.	54	not connected
UV3 - UV0	55 - 58	multiplexed PAL or NTSC colour difference signal output or SECAM CS input signal from the SECAM decoder. Output data format is two's complement. The multiplexer is synchronized to the rising-edge of $\overline{\text{BL}}$
n.c.	59 - 63	not connected
$\overline{\text{FOE}}$	64	fast output enable signal (active LOW); sets D1 - D7 and UV0 - UV3 outputs to the HIGH-impedance Z-state
SS0 - SS1	65 - 66	source select output signals, set via the I <sup>2</sup> C-bus; used to control the input switch (e.g. TDA8708)
n.c.	67	not connected
AFCC	68	additional output for circuit control; activated via the I <sup>2</sup> C-bus



## Digital multistandard TV decoder

SAA9051

**FUNCTIONAL DESCRIPTION (see Fig.1)**

The S-DMSD performs the demodulation and decoding for all quadrature modulated colour TV standards (PAL-B, G, H, I, M, N, NTSC 4.43 MHz and NTSC-M), as well as performing luminance, and parts of the synchronization, processing for TV standards (PAL, NTSC and SECAM). All of the controllable functions, user as well as factory adjustments, are accessed via I<sup>2</sup>C-bus thereby enhancing the adaptability of the digital TV concept.

Operation is based on a line-locked sampling frequency of 13.5 MHz, thus making the system fully adaptable to all line frequencies. Only one crystal is required for all TV standards.

The S-DMSD is designed to operate in conjunction with the SAA9057A Clock Generating Circuit (CGC). If the CGC is not utilized the designer must ensure:

- a reset pulse is applied to the S-DMSD after a power failure

**Y/C processing**

In the Y/C mode:

- The chrominance signal is input at the IO port (IO0 - IO7) and transmitted via the input switch/SECAM delay compensation circuit (multiplexer) to the chrominance bandpass filter, 'see section Chrominance path'.
- The other components, Y signal and synchronization pulse, are input via inputs CVBS0 - CVBS7 and transmitted via the input switch/SECAM delay compensation circuit to the luminance prefilter.

**CVBS processing**

In the CVBS mode:

- The CVBS signal is separated into its luminance (VBS) and chrominance (CG) parts by the chrominance trap and bandpass circuits. These circuits can be switched by the standard identification signals (CCFR0, CCFR1/YPN) according to the detected colour-carrier frequency, 3.58 MHz or 4.43 MHz.
- On reception of a SECAM signal the signal is transmitted to the SECAM decoder (SAA9056) via the IO port (IO0 - IO7). Bit CT enables the 3-state buffer between both parts.

**Luminance path**

After the chrominance trap stage (see Fig.1), the luminance path is separated into three Channels as follows:

**CHANNEL 1 SIGNAL**

The Channel 1 signal is transmitted to the programmable bandpass filter where the high luminance frequencies are removed (centre frequency is programmable via bits BP1 and BP2). The BC signal is transmitted to the coring (corner correction) stage where low amplitude noise is removed (amount of low amplitude noise removal is programmable via bits COR1 and COR2). The HF signal is transmitted to the weighting and adding stage, see section 'Combining Channel 1 and Channel 2 signals'.

**CHANNEL 2 SIGNAL**

The Channel 2 signal is transmitted to the fixed delay compensation stage where delay compensation and black-level adjustment occurs. The DCA signal is transmitted to the

weighting and adding stage, see section 'Combining Channel 1 and Channel 2 signals'.

**COMBINING CHANNEL 1 AND CHANNEL 2 SIGNALS**

The Channel 1 HF signal is weighted and added to the Channel 2 DCA signal. The combined signals are matched to the specified amplitude and the word size is reduced to 7 bits. The AVD signal is transmitted to the variable delay compensation stage where compensation for IF group delays occurs, the amount of delay is programmable (from -4 to +3 LL3 clock cycles, see note) via bits YDLO - YDL2. The Y signal is transmitted to the time multiplexed interface where the signal is output via D1 - D7.

**CHANNEL 3 SIGNAL**

The Channel 3 VB signal is transmitted to the prefilter synchronization stage, see section 'Synchronization path'.

**Note**

Differences in the delay compensation required for PAL and NTSC are catered for by identification signal YPN which switches the chrominance trap to the appropriate colour-carrier frequency 3.58 MHz or 4.43 MHz.

**Chrominance path (see Fig.1)**

The chrominance CG signal is transmitted from the chrominance bandpass stage to the gain control circuit (see note 1). The gain control stage ensures that the chrominance signal has constant burst amplitude. The GQ signal is transmitted to the quadrature demodulator, where demodulation of the quadrature modulated chrominance GQ signal to colour difference signals occurs.

## Digital multistandard TV decoder

SAA9051

The QLU and QLV signals are transmitted to a low-pass filter. The LCU and LCV signals are transmitted to the limiter and comb-filter stage. The comb-filter stage (see note 2) separates the remaining vertically correlated luminance components for NTSC (for PAL, the signals are phase corrected). The CCU and CCV signals are transmitted to the colour-killer and PAL switch stage (see note 3). At this stage signals which do not comply with the selected standard are removed. In the PAL mode this stage restores the correct phase of the V signal. The signals are then transmitted to the time multiplexed interface and output via UV0 - UV3.

### Notes

1. The gain control stage is controlled by the AG signal which is derived from the amplitude and colour-killer detector stage (ACKD). A non-standard burst-to-amplitude ratio results in the automatic colour-leveling stage functioning as an amplitude detector to ensure correct amplitude and avoid overflow/limiter defects.
2. The comb-filter can be altered from alternate to non-alternate mode by the ALT signal.
3. The colour-killer and PAL switching stages are controlled by the amplitude and colour-killer detection circuit using the AC1 and CD signals.

### COLOUR-CARRIER FREQUENCY REGENERATION

The regeneration of the colour-carrier frequency is performed by the phase-locked-loop (PLL) which comprises a quadrature demodulator, low-pass filter, burst gate, loop filter 1 and divider/discrete time oscillator (DTO1). The DTO1 is controlled by the standard identification signals CCFR0 - CCFR1 and the Hue signal which influences the demodulation phase of the chrominance signal.

### Synchronization path

In the synchronization circuit, prefilter synchronization is implemented to normalize the synchronization pulse slopes. A synchronization-slicer provides the detected synchronization pulses (SP) to the horizontal and vertical processing and phase detector stages.

### HORIZONTAL AND VERTICAL PROCESSING

The horizontal and vertical processing comprises part of a PLL circuit for regeneration of the horizontal synchronization (HS) and an adaptive filter for detection of the vertical synchronization (VS). The horizontal and vertical processing also generates:

- coincidence signal (HLOCK) which controls the mute function
- standard identification signal (FD) which identifies nominal 525 or 625 lines per picture.

### PHASE DETECTORS

The phase detectors that receive the SP signal, also part of the PLL, control the generation of the line-locked clock (PL). Loop filter 2, which has a variable bandwidth, dependent on the time constant signal (VTR), generates two increment signals (INC1 and INC2) with different delays. INC2 is programmable via the increment delay signal (IDEL). INC1 corrects the regenerated subcarrier frequency at DTO1 and INC2 performs phase incrementing of DTO2. The crystal clock generator provides a stable 24.576 MHz clock input to DTO2 which in turn supplies the 4-bit DAC with a digital control signal of 432 or 429 times the line frequency. The analog output LFCO, from the DAC, is transmitted to the SAA9057A (CGC).

### Output interface

The signals OEY, OEC, CO, CI and CD control the output interface (see Fig.6). All but one of these signals are received via the I<sup>2</sup>C-bus, except the CD signal which is detected in the S-DMSD. A power-ON reset results in these signals being set to zero.

## Digital multistandard TV decoder

SAA9051

**Table 1** Vertical Noise limiter (VNL) signal

VNL	OUTPUT
0	VNL bypassed
1	VNL active

**Table 2** CO, CI and CD signals

CO	CI	CD	OUTPUTS	OUTPUT STATUS
0	X	X	UV0 - UV3	colour OFF (zero)
1	0	0	UV0 - UV3	colour OFF (controlled by CD)
1	0	1	UV0 - UV3	colour ON (controlled by CD)
1	1	X	UV0 - UV3	colour forced ON

**Where:**

X = don't care.

**Table 3** OEC, OEY, FOE, BL, D1 - D7 and UV0 - UV3 signals

OEC	OEY	FOE	BL, VS, HS	D1 - D7	UV0 - UV3	REMARKS
0	0	X	HIZS	HIZS	HIZS	status after power-ON reset
1	1	1	active	HIZS	HIZS	
1	1	0	active	active	active	
0	1	1	active	HIZS	HIZS	
0	1	0	active	active	active	

**Where:**

X = don't care

HIZS = HIGH-impedance Z-state.

**Note to Table 3**

Combinations other than those shown in Table 3 are not allowed.

**FOE signal**

In PIPCO (picture-in-picture controller, SAA9068) applications, the PIPCO requires access to the digital YUV-bus on a pixel time-base. This requirement is catered for by PIPCO generated signal FOE, which forces all data output of the S-DMSD and DSD (SAA9056) into the HIGH-impedance Z-state. The FOE signal does not affect the

synchronization data lines (HS and VS) or the blanking data line (BL), see Fig.7.

**CS signal**

The CS signal is transmitted from the digital SECAM decoder (DSD) during the horizontal-blanking period and is received via the UV2 input (see Fig.6). The CS bit is read by the S-DMSD once per line at LL3 clock cycle number 748 (see Fig.8).

**I<sup>2</sup>C bus interface (see Tables 1 to 3)**

The following control signals are received via the I<sup>2</sup>C bus interface:

- standard identification signals (CCFR0, CCFR1, ALT, FS, YPN)
- video recorder/TV time constant (VTR)
- hue control (HUE)
- delay programming of the horizontal signals (HS, HC, HSY)

---

**Digital multistandard TV decoder****SAA9051**

---

- increment-delay (IDEL)
- luminance aperture-correction control (BY, PF, BP1, BP2, COR2, COR1, AP2, AP1)
- luminance delay compensation (YDL0, YDL1, YDL2)
- fixed clock generation command (HPLL)
- internal colour ON/OFF (CO)
- internal colour forced ON, test purposes only (CI)
- vertical noise limiter (VNL) active/bypassed
- luminance and sync output enable (OEY)
- chrominance output enable (OEC)
- switch signals (source select signals SS0, SS1, SS2, SS3)
- additional output for circuit control (AFCC)
- chrominance source select CVBS/chrominance input/output (CT/YC).
- SECAM chrominance delay compensation (SCDC0, SCDC1, SCDC2, SCDC3, SCDC4, SCDC5, SCDC6).
- horizontal sync (HSY) and clamp (HC) pulse disable (SYC).

Signals transmitted from the S-DMSD via the I<sup>2</sup>C bus are:

- standard identification signals (FD, CS)
- colour-killer status signal (CD)
- coincidence information (HLOCK)
- power-on-reset of S-DMSD (PONRES).

Digital multistandard TV decoder

SAA9051

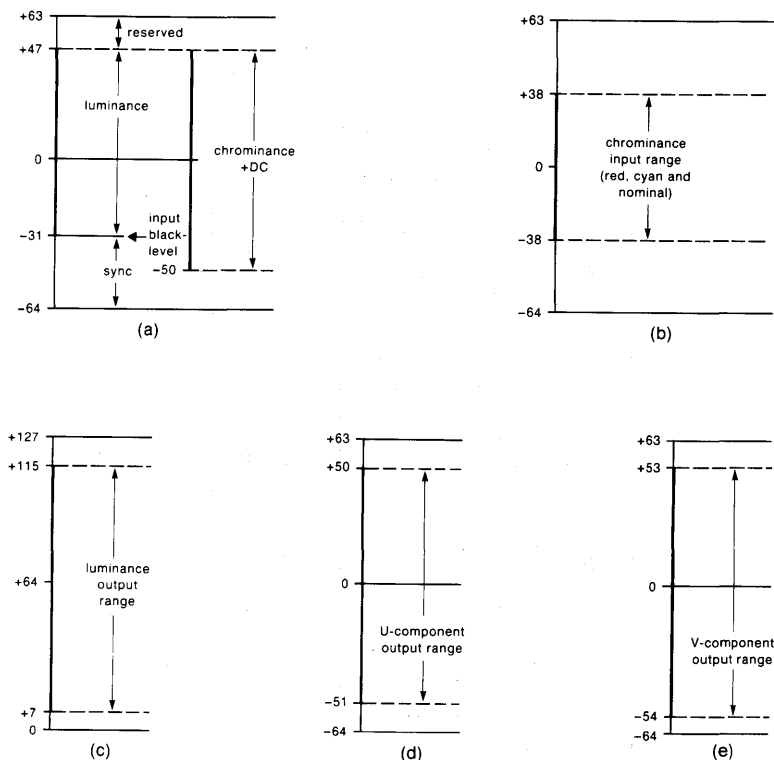

7228075

- (a) CVBS1 to CVBS7 input range
- (b) IO1 to IO7 input range
- (c) Y output range
- (d) U output range (B-Y)
- (e) V output range (R-Y)

Fig.4 Diagram showing input/output range of the S-DMSD; all levels in EBU colour bar, values in binary, 100% luminance and 75% chrominance amplitude.

Digital multistandard TV decoder

SAA9051

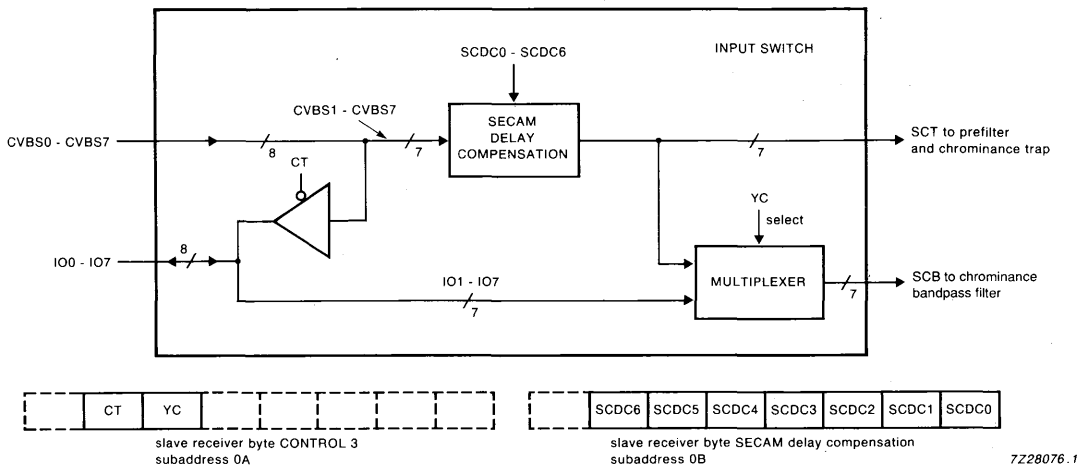

Fig.5 Schematic diagram of the input switch.

Digital multistandard TV decoder

SAA9051

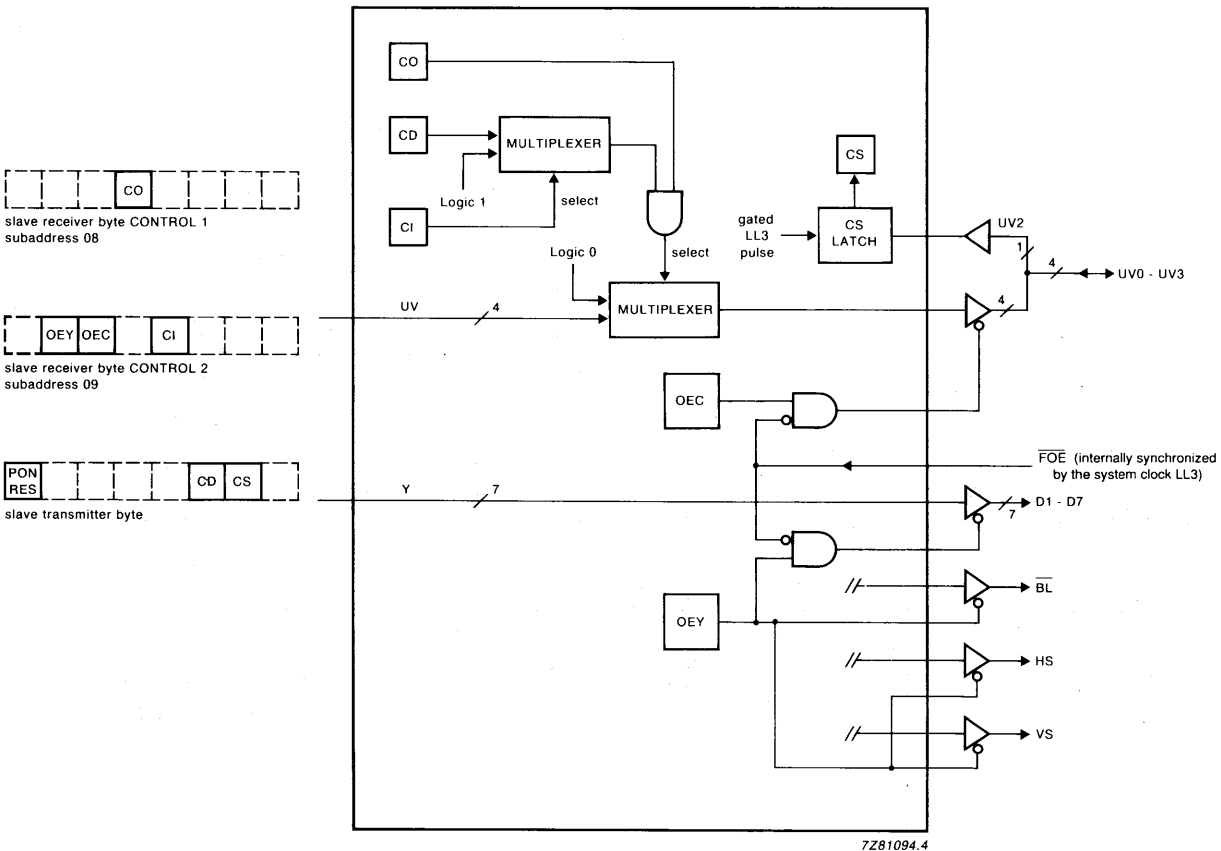

Fig.6 Schematic diagram of control signals at the output interface.

Digital multistandard TV decoder

SAA9051

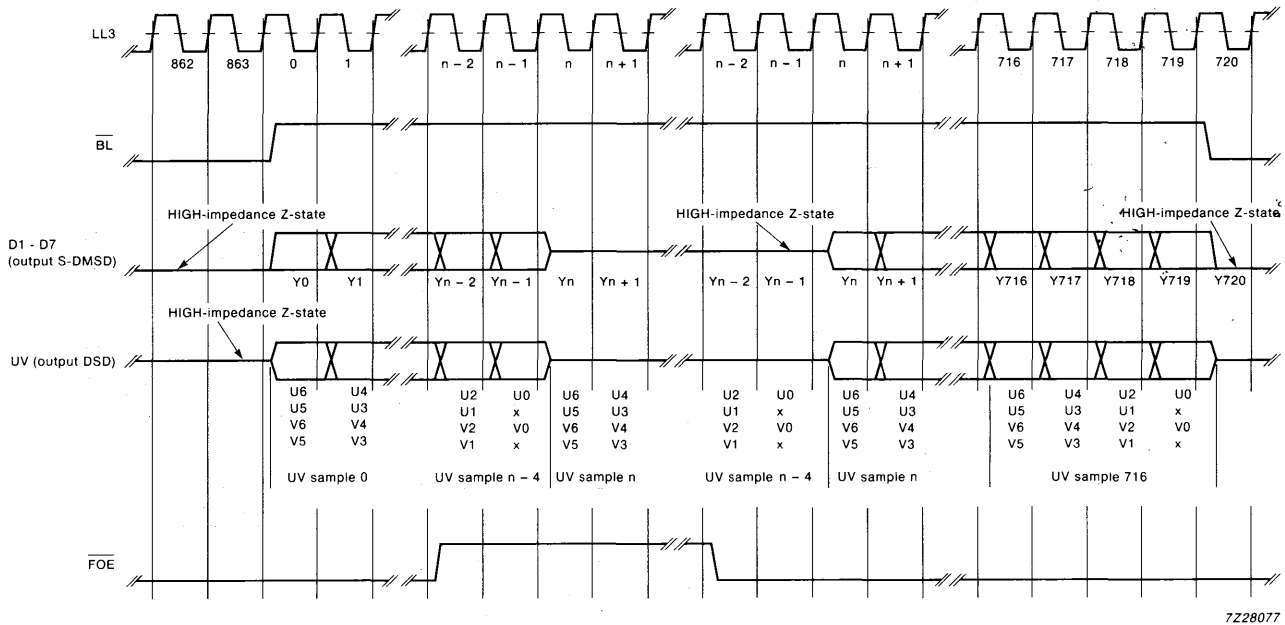
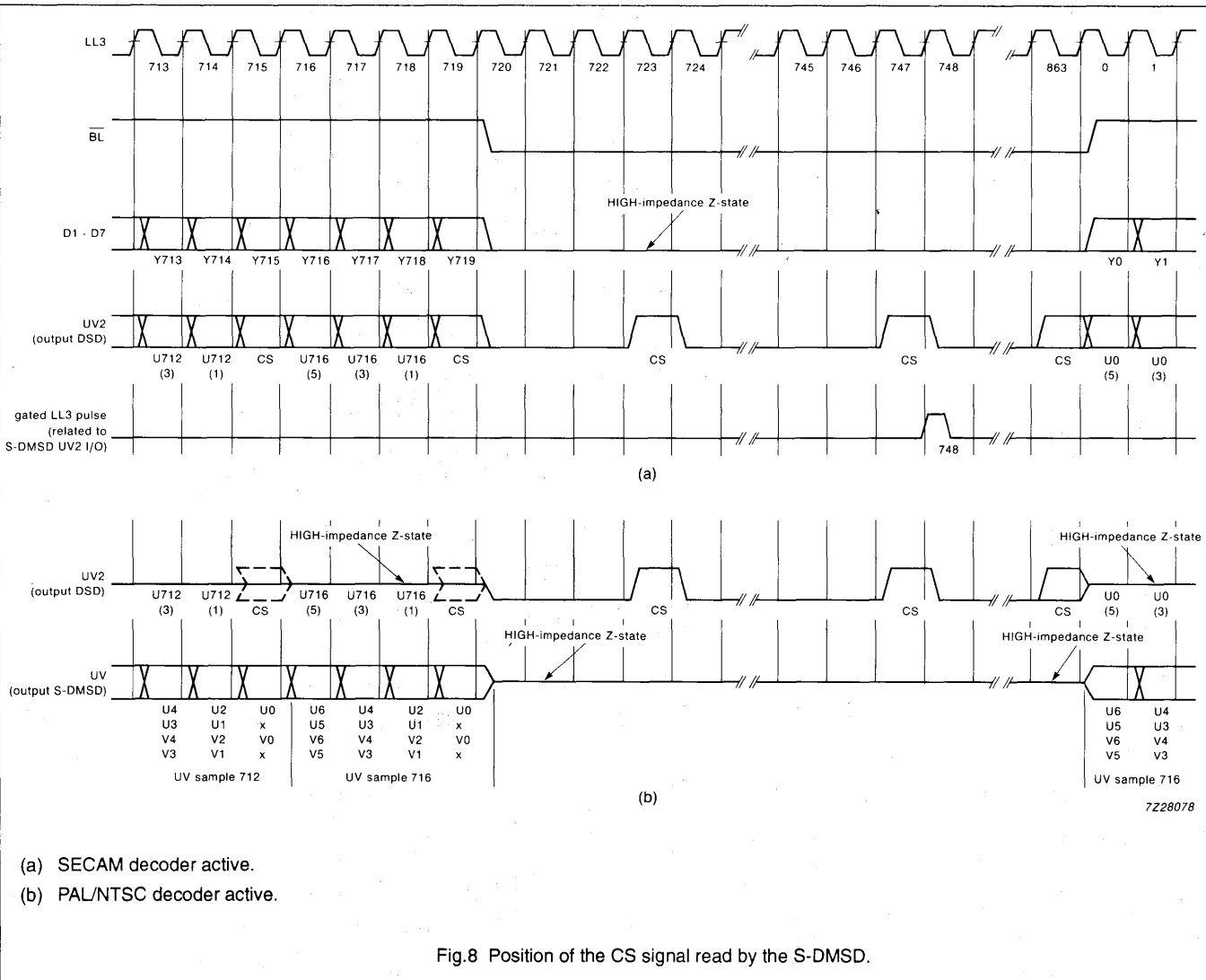

Fig.7 Timing waveform of the output data and FOE signals.



Digital multistandard TV decoder

SAA9051



## Digital multistandard TV decoder

SAA9051

Table 4 Slave addresses

SLAVE RECEIVER ADDRESS									REMARKS
SA	A6	A5	A4	A3	A2	A1	A0	*	
0	1	0	0	0	1	0	1	0	binary value (8A hex)
1	1	0	0	0	1	1	1	0	binary value (8E hex)

## Where:

- \* = logic 0, receiver mode
- \* = logic 1, transmitter mode.

## SLAVE RECEIVER ORGANIZATION

## Slave address and receiver format

There are two slave addresses, programmable via input SA, which determine the operating mode of the S-DMSD, see Table 4.

Table 5 Subaddress byte and data byte formats

REGISTER FUNCTION	SUB ADDRESS	DATA BYTE							
		D7	D6	D5	D4	D3	D2	D1	D0
Increment delay IDEL	00	A07	A06	A05	A04	A03	A02	A01	A00
HSY start time	01	A17	A16	A15	A14	A13	A12	A11	A10
HSY stop time	02	A27	A26	A25	A24	A23	A22	A21	A20
HC start time	03	A37	A36	A35	A34	A33	A32	A31	A30
HC stop time	04	A47	A46	A45	A44	A43	A42	A41	A40
HS start time (after PHI1)	05	A57	A56	A55	A54	A53	A52	A51	A50
Horizontal peaking	06	BY	PF	BP2	BP1	COR2	COR1	AP2	AP1
Hue control	07	A77	A76	A75	A74	A73	A72	A71	A70
Control 1	08	HPLL	FS	VTR	CO	ALT	YPN	CCFR1	CCFR0
Control 2	09	VNL	OEY	OEC	X	CI	AFCC	SS1	SS0
Control 3	0A	SYC	CT	YC	SS3	SS2	YDL2	YDL1	YDL0
SECAM delay compensation	0B	X	SCDC6	SCDC5	SCDC4	SCDC3	SCDC2	SCDC1	SCDC0
Reserved	0C - 0F	X	X	X	X	X	X	X	X

## Where:

X = don't care.

## Digital multistandard TV decoder

SAA9051

## Notes to Table 5

1. The subaddress is automatically incremented. This enables quick initialization, within one transmission, by the I<sup>2</sup>C-bus controller.
2. The subaddresses shown are acknowledged by the device. Subaddresses 10 to 1F (reserved for the SECAM decoder SAA9056) are not acknowledged. The subaddress counter wraps-around from 1F to 00. Subaddresses 20 to FF are not allowed.
3. After power-on-reset the control registers 1 to 3 (subaddresses 08, 09 and 0A) are, with the exception of bits YDL0 - YDL2 of counter 3, set to logic 0. All other registers are undefined.
4. Prior to a reset of the IC all outputs are undefined.
5. The least significant bit of an analog control or alignment register is defined as AX0.

SUBADDRESS 00

Table 6 Increment delay control IDEL (application dependent)

DECIMAL MULTIPLIER	DELAY TIME (STEP SIZE = 2/13.5 MHz = 148 ns)	CONTROL BITS*							
		A07	A06	A05	A04	A03	A02	A01	A00
-1 to -110	-148 ns (min. value)	1	1	1	1	1	1	1	1
-111 to -214	-16.3 μs (outside available range)	1	0	0	1	0	0	1	0
-215	-16.44 μs	1	0	0	1	0	0	0	1
-214	-31.7 μs (max. value if FS = logic 1)	0	0	1	0	1	0	1	0
-215	-31.85 μs (outside central counter range if FS = logic 1)**	0	0	1	0	1	0	0	1
-216	-32 μs (max. value if FS = logic 0)**	0	0	1	0	1	0	0	0
-217 to -256	-32.148 μs (outside central counter if FS = logic 0)**	0	0	1	0	0	1	1	1
-256	-37.9 μs (outside central counter)**	0	0	0	0	0	0	0	0

## Where:

- \* A sign bit, designated A08 and internally set to HIGH, indicate values are always negative.
- \*\* The horizontal PLL does not operate in this condition. The system clock frequency is set to a value fixed by the last update and is within ± 7.1% of the nominal frequency.

## Digital multistandard TV decoder

SAA9051

## SUBADDRESS 01

**Table 7** Horizontal synchronization HSY start time (application dependent)

DECIMAL MULTIPLIER	DELAY TIME (STEP SIZE = 1/13.5 MHz = 74 ns)	CONTROL BITS							
		A17	A16	A15	A14	A13	A12	A11	A10
+191 to +1	-14.2 $\mu$ s (max. negative value)	1	0	1	1	1	1	1	1
0	0 $\mu$ s reference point	0	0	0	0	0	0	0	0
-1 to -64	+0.074 $\mu$ s	1	1	1	1	1	1	1	1
	+4.7 $\mu$ s (max. positive value)	1	1	0	0	0	0	0	0

## SUBADDRESS 02

**Table 8** Horizontal synchronization HSY stop time (application dependent)

DECIMAL MULTIPLIER	DELAY TIME (STEP SIZE = 1/13.5 MHz = 74 ns)	CONTROL BITS							
		A27	A26	A25	A24	A23	A22	A21	A20
+191 to +1	-14.2 $\mu$ s (max. negative value)	1	0	1	1	1	1	1	1
0	0 $\mu$ s reference point	0	0	0	0	0	0	0	0
-1 to -64	+0.074 $\mu$ s	1	1	1	1	1	1	1	1
	+4.7 $\mu$ s (max. positive value)	1	1	0	0	0	0	0	0

## SUBADDRESS 03

**Table 9** Horizontal clamp HC start time (application dependent)

DECIMAL MULTIPLIER	DELAY TIME (STEP SIZE = 1/13.5 MHz = 74 ns)	CONTROL BITS							
		A37	A36	A35	A34	A33	A32	A31	A30
+127 to +1	-9.4 $\mu$ s (max. negative value)	0	1	1	1	1	1	1	1
0	0 $\mu$ s reference point	0	0	0	0	0	0	0	0
-1 to -128	+0.074 $\mu$ s	1	1	1	1	1	1	1	1
	+9.5 $\mu$ s (max. positive value)	1	0	0	0	0	0	0	0

## Digital multistandard TV decoder

SAA9051

SUBADDRESS 04

**Table 10** Horizontal clamp HC stop time (application dependent)

DECIMAL MULTIPLIER	DELAY TIME (STEP SIZE = 1/13.5 MHz = 74 ns)	CONTROL BITS							
		A47	A46	A45	A44	A43	A42	A41	A40
+127 to +1	-9.4 $\mu$ s (max. negative value)	0	1	1	1	1	1	1	1
0	0 $\mu$ s reference point	0	0	0	0	0	0	0	0
-1 to -128	+0.074 $\mu$ s	1	1	1	1	1	1	1	1
	+9.5 $\mu$ s (max. positive value)	1	0	0	0	0	0	0	0

SUBADDRESS 05

**Table 11** Horizontal synchronization HS start time after PHI1 (application dependent); 50 Hz; 625 lines (FS = 0)

DECIMAL MULTIPLIER	DELAY TIME (STEP SIZE = 4/13.5 MHz = 296 ns)	CONTROL BITS							
		A57	A56	A55	A54	A53	A52	A51	A50
+127 to +109	forbidden; outside available central counter range	0	1	1	1	1	1	1	1
	forbidden; outside available central counter range	0	1	1	0	1	1	0	1
+108 to +1	-32 $\mu$ s (max. negative value)	0	1	1	0	1	1	0	0
0	0 $\mu$ s reference point	0	0	0	0	0	0	0	0
-1 to -107	+0.296 $\mu$ s	1	1	1	1	1	1	1	1
	+31.7 $\mu$ s (max. positive value)	1	0	0	1	0	1	0	1
-108 to -128	forbidden; outside available central counter range	1	0	0	1	0	1	0	0
	forbidden; outside available central counter range	1	0	0	0	0	0	0	0

## Digital multistandard TV decoder

SAA9051

**Table 12** Horizontal synchronization start time after PHI1 (application dependent); 60 Hz; 525 lines (FS = 1)

DECIMAL MULTIPLIER	DELAY TIME (STEP SIZE = 4/13.5 MHz = 296 ns)	CONTROL BITS							
		A57	A56	A55	A54	A53	A52	A51	A50
+127 to +107	forbidden; outside available central counter range	0	1	1	1	1	1	1	1
+106 to +1	-31.8 $\mu$ s (max. negative value)	0	1	1	0	1	0	1	0
0	0 $\mu$ s reference point	0	0	0	0	0	0	0	0
-1 to -107	+0.294 $\mu$ s	1	1	1	1	1	1	1	1
-108 to -128	+31.5 $\mu$ s (max. positive value)	1	0	0	1	0	1	0	1
	forbidden; outside available central counter range	1	0	0	1	0	1	0	0
	forbidden; outside available central counter range	1	0	0	0	0	0	0	0

**Programming IDEL, HSY, HC and HS**

The variables IDEL, HSY, HC and HS are programmed using data words via the I<sup>2</sup>C-bus. In the following examples a decrease in value corresponds to an increase in time.

**IDEL (SEE FIG.9)**

The IDEL data word compensates for the time delays in data processing between loop filter 2, quadrature demodulator and internal/external (system) signal paths. The internal delay ( $t_{REF}$ ) is the period required for INC1 to pass from loop filter 2, through the divider and DTO1. This delay corrects the relationship between the subcarrier frequency and the line frequency. The external path is a result of the following time delays (time delay is given in term of LL3 clock cycles):

- $t_{DEL}$ : programmable delay time

- $t_a$ : processing time of DTO2 and the DAC
- $t_b$ : chrominance bandpass and gain control stage delay times
- $t_{CGC}$ : clock generator circuit delay time
- $t_{ADC}$ : analog-to-digital converter delay time
- $t_{INP}$ : input switch delay time.

As delay  $t_a$  and  $t_b$  are known constants,  $t_{DEL}$  is programmed in the range of -115 to -214/216 LL3 clock cycles, as follows:

$$t_{DEL} = -115 - 0.5 (* - t_{CGC} - t_{ADC} - t_{INP}).$$

\* Value to be fixed.

**HSY**

Referring to Fig.10 point (1) and periods a and b:

- HSY start time =  $t_{(1)} - a$  (LL3 clock cycles)

- HSY stop time =  $t_{(1)} - b$  (LL3 clock cycles)

Programming range of HSY start/stop time: +191 to -64 (LL3 clock cycles).

**HC**

Referring to Fig.10 point (1) and periods c and d:

- HC start time =  $t_{(1)} - c$  (LL3 clock cycles)
- HC stop time =  $t_{(1)} - d$  (LL3 clock cycles)

Programming range of HC start/stop time: +127 to -128 (LL3 clock cycles).

**HS**

The HS reference positions in PAL and NTSC modes are shown in Fig.10 at points (3) and (4) respectively. To move the HS pulse to the centre of blanking pulse  $\overline{BL}$  the following equation is used:

---

## Digital multistandard TV decoder

SAA9051

---

- HS (NTSC);  
position of HS relative to the zero point (LL3 clock cycles)  
4 LL3 clock cycles
- HS (PAL);  
position of HS relative to the zero point (LL3 clock cycles)  
4 LL3 clock cycles

The length of HS is 64 LL3 clock cycles.

### Programming of the luminance path of the S-DMSD

The VBS (without chrominance) or CVBS input signal enters the prefilter (a high-pass transfer function with maximum gain of 9.5 dB). The control bit PF switches the filter into the bypass mode. The next stage is the chrominance trap

which can be programmed (zero point) to 4.43 MHz (PAL) or 3.58 MHz (NTSC) by the control bit YPN. Bit BY activates the bypass function for the Y/G mode of the S-DMSD. The chrominance trap output signal is then divided into three Channels as described in section 'Luminance path'.

Digital multistandard TV decoder

SAA9051

7222076.2

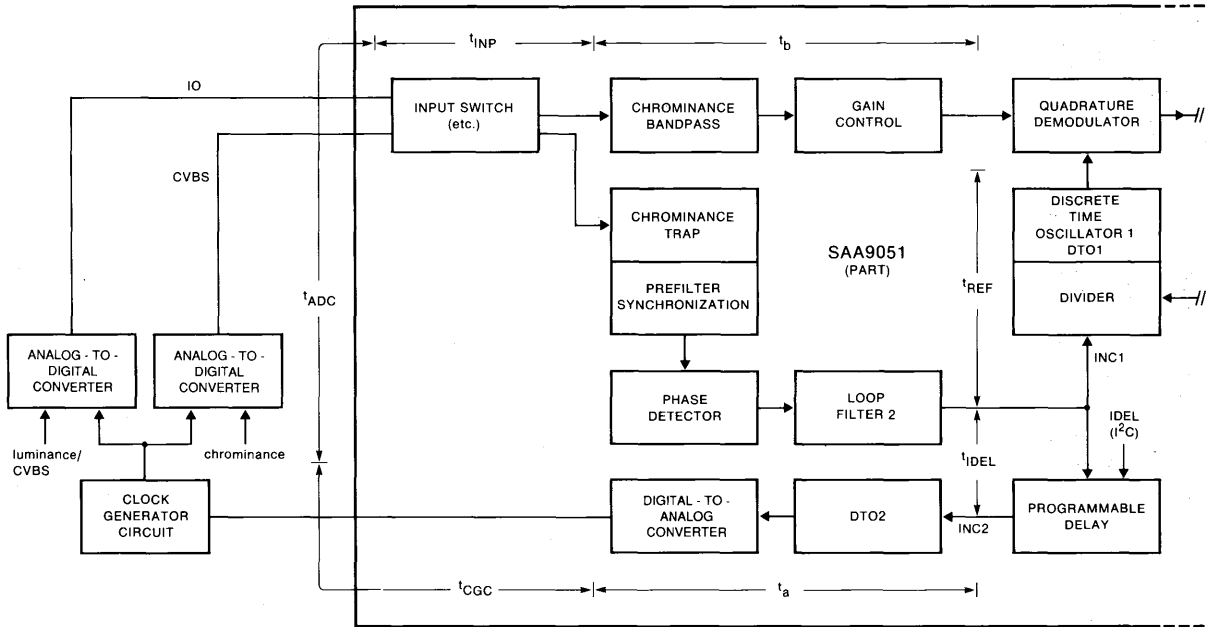
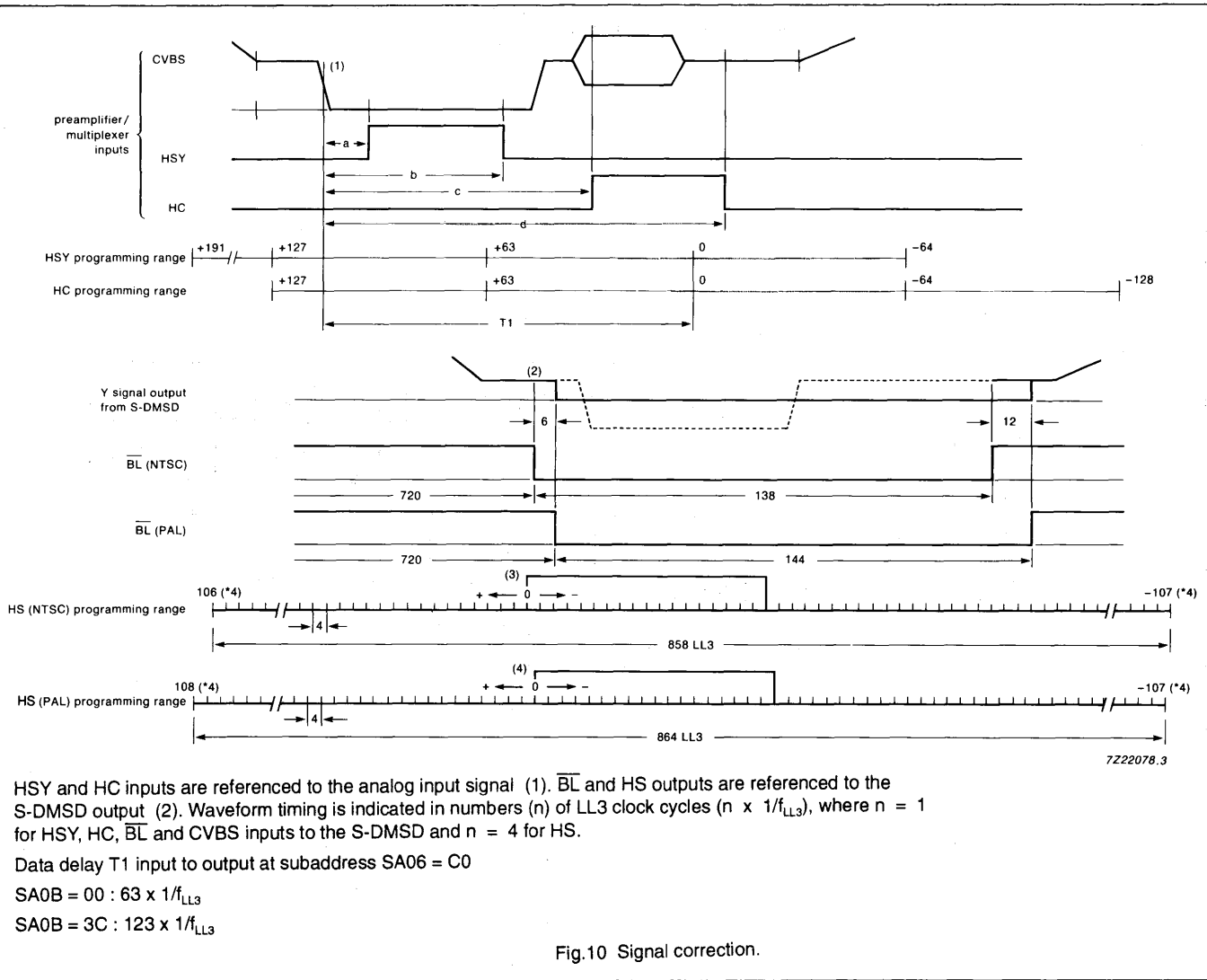

Fig.9 Compensation of delay times by incrementing delay control IDEL.



Digital multistandard TV decoder

SAA9051



HSY and HC inputs are referenced to the analog input signal (1).  $\overline{BL}$  and HS outputs are referenced to the S-DMSD output (2). Waveform timing is indicated in numbers (n) of LL3 clock cycles ( $n \times 1/f_{LL3}$ ), where  $n = 1$  for HSY, HC,  $\overline{BL}$  and CVBS inputs to the S-DMSD and  $n = 4$  for HS.

Data delay  $T_1$  input to output at subaddress SA06 = C0

SA0B = 00 :  $63 \times 1/f_{LL3}$

SA0B = 3C :  $123 \times 1/f_{LL3}$

Fig.10 Signal correction.

Digital multistandard TV decoder

SAA9051

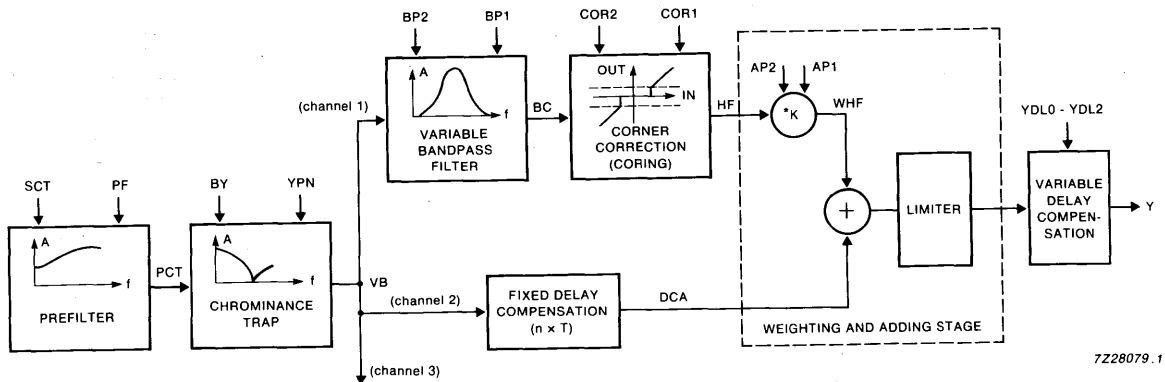

Fig.11 Luminance path of the S-DMSD.

## Digital multistandard TV decoder

SAA9051

## SUBADDRESS 06

**Table 13** Chrominance trap select (BY switches the chrominance trap to the bypass mode; YPN selects the notch-frequency)

CHROMINANCE TRAP	CONTROL BITS	
	BY (SA06, D7)	YPN (SA08, D2)
PAL (4.43 MHz)	0	0
NTSC (3.58 MHz)	0	1
bypass	1	X

**Table 14** Disconnecting the luminance prefilter (user dependent)

PREFILTER	CONTROL BIT PF (SA06, D6)
ON	0
OFF	1

**Table 15** Bandpass control (BP1 and BP2 control the centre frequency of the bandpass filter, see Figs 13 to 16)

BANDPASS TYPE (CENTRE FREQUENCY)	CONTROL BITS	
	BP2 (SA06, D5)	BP1 (SA06, D4)
type 1 (4.1 MHz)	0	0
type 2 (3.8 MHz)	0	1
type 3 (2.6 MHz)	1	0
type 4 (2.9 MHz)	1	1

**Table 16** Coring threshold level (COR1 and COR2 control the suppression of low amplitude and high frequency signal components, see Fig.12)

THRESHOLD	Fig.12	CONTROL BITS	
		COR2 (SA06, D3)	COR1 (SA06, D2)
coring off		0	0
coring on (4 bits of 12 bits)	a	0	1
coring on (5 bits of 12 bits)	b	1	0
coring on (6 bits of 12 bits)	c	1	1

**Note**

The thresholds are related the word width of the bandpass filter (12 bits).

**Table 17** Aperture correction factor (AP1 and AP2 select the weighting factor K of the high frequency (HF) luminance components, see Fig.11)

WEIGHTING FACTOR K	CONTROL BITS	
	AP2 (SA06, D1)	AP1 (SA06, D0)
0	0	0
0.25	0	1
0.5	1	0
1	1	1

Digital multistandard TV decoder

SAA9051

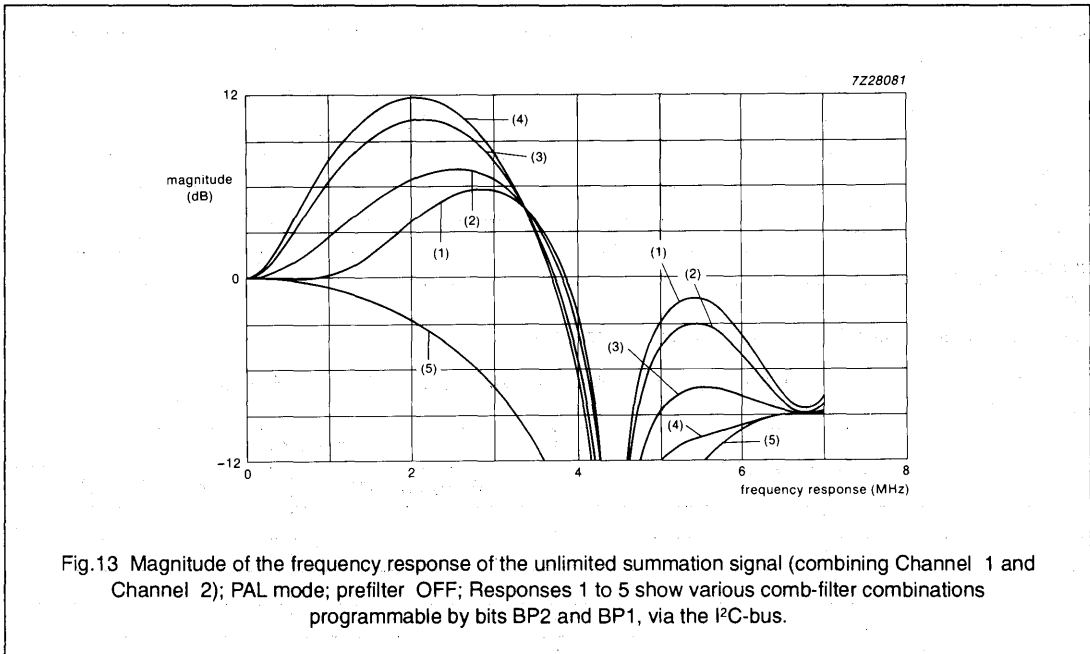
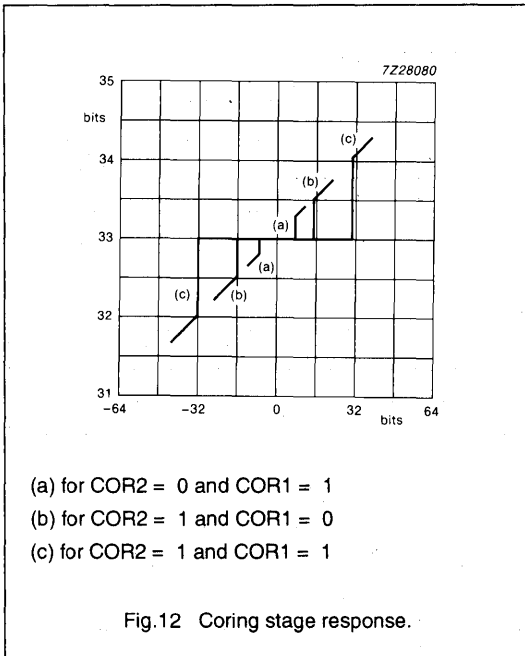

Digital multistandard TV decoder

SAA9051

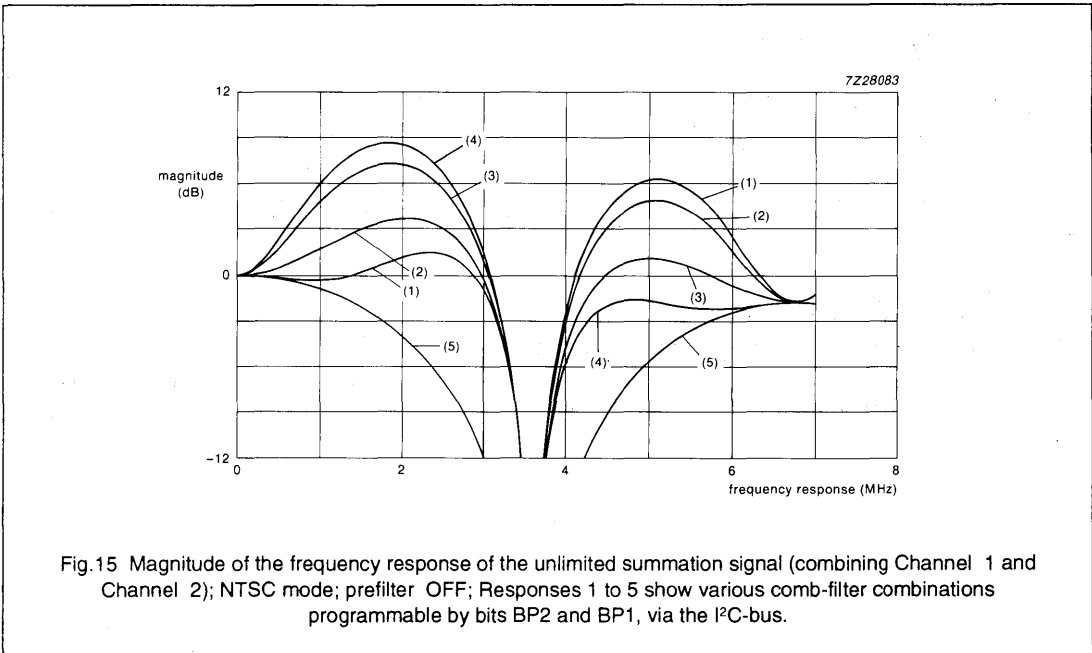
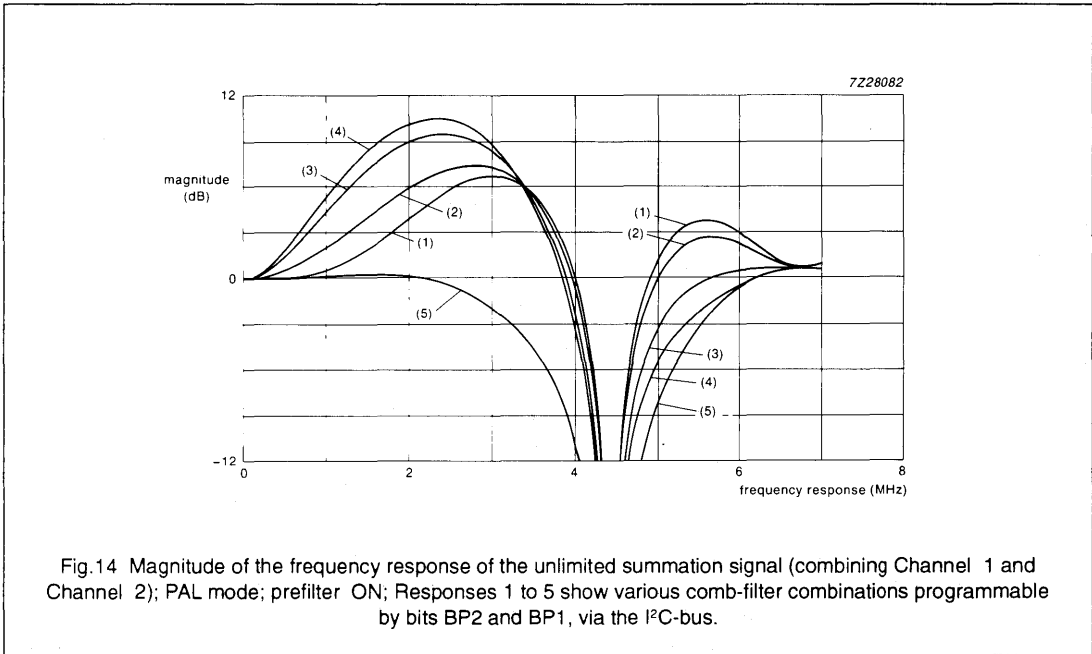

Digital multistandard TV decoder

SAA9051

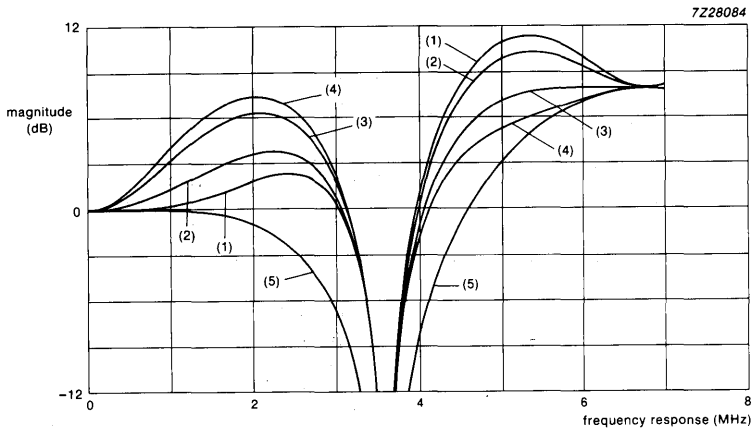

Fig.16 Magnitude of the frequency response of the unlimited summation signal (combining Channel 1 and Channel 2); NTSC mode; prefilter ON; Responses 1 to 5 show various comb-filter combinations programmable by bits BP2 and BP1, via the I<sup>2</sup>C-bus.

SUBADDRESS 07

Table 18 Hue phase (user dependent, see notes 1 to 3)

HUE PHASE (deg)	CONTROL BITS							
	A77	A76	A75	A74	A73	A72	A71	A70
+178.6 to 0	1	1	1	1	1	1	1	1
0	1	0	0	0	0	0	0	0
0 to -180	0	0	0	0	0	0	0	0

Notes to Table 18

1. Step size per least significant bit (A70) = 1.4 degree.
2. Reference point for positive colour difference signals = 0 degree.
3. The hue phase may be shifted ±180 degrees from the reference point using bit A77, the colour difference signals are then switched from normally positive to negative polarity.

## Digital multistandard TV decoder

SAA9051

SUBADDRESS 08

**Table 19** Horizontal clock PLL (application dependent)

FUNCTION	HPLL CONTROL BIT (SA08, D7)
horizontal clock PLL open, horizontal frequency fixed	1
horizontal clock PLL closed	0

**Table 20** Field frequency select (system mode dependent)

FUNCTION	CONTROL BIT FS (SA08, D6)
60 Hz; 525-line mode	1
50 Hz; 625-line mode	0

**Table 21** VTR/TV mode select (system mode dependent)

FUNCTION	CONTROL BIT VTR (SA08, D5)
VTR mode	1
TV mode	0

**Table 22** Colour on control (system mode dependent)

FUNCTION	CONTROL BIT CO (SA08, D4)
colour ON	1
colour OFF (all colour output samples zero)	0

**Table 23** Alternate/non-alternate mode (system mode dependent)

FUNCTION	CONTROL BIT ALT (SA08, D3)
alternate mode (PAL)	1
non-alternate mode (NTSC)	0

**Table 24** Chrominance trap select and amplitude matching (system mode dependent)

CHROMINANCE TRAP	CONTROL BIT YPN (SA08, D2)
3.58 MHz	1
4.43 MHz	0

**Table 25** Colour carrier frequency control (system mode dependent)

COLOUR CARRIER FREQUENCY	CONTROL BITS	
	CCFR1 (SA08, D1)	CCFR0 (SA08, D0)
4 433 618.75 Hz (PAL-B, G, H, 1; NTSC 4.43)	0	0
3 575 611.49 Hz (PAL-M)	0	1
3 582 056.25 Hz (PAL-N)	1	0
3 579 545 Hz (NTSC-M)	1	1

## Digital multistandard TV decoder

SAA9051

SUBADDRESS 09

**Table 26** Vertical noise limiter.

FUNCTION	CONTROL BIT VNL (SA09, D7)
VNL active	1
VNL bypassed	0

**Table 27** Y-output enable (system mode dependent)

FUNCTION	CONTROL BIT OEY (SA09, D6)
outputs D1 - D7 and $\overline{\text{BL}}$ active	1
outputs D1 - D7 and $\overline{\text{BL}}$ HIGH-impedance Z-state	0

**Table 28** Chrominance output enable (system mode dependent)

FUNCTION	CONTROL BIT OEC (SA09, D5)
outputs UV0 - UV3 active; if CD = logic 1, chrominance signal output; if CD = logic 0, zero signal	1
outputs UV0 - UV3 HIGH-impedance Z-state	0

**Table 29** Internal colour forced ON/OFF (test purposes only)

FUNCTION	CONTROL BIT CI (SA09, D3)
colour forced ON, if CO = logic 1 (CD = X) or colour OFF, if CO = logic 0 (CD = X)	1
colour OFF, if CO = logic 0 (CD = X) or colour controlled by CD, if CO = logic 1	0

**Where:**

X = don't care.

**Table 30** Additional output for circuit control

FUNCTION	CONTROL BIT AFCC
output AFCC = HIGH	1
output AFCC = LOW	0

**Table 31** Source-select (system mode dependent)

FUNCTION	CONTROL BIT SS0 - SS3
output SS0 - SS3 = HIGH	1
output SS0 - SS3 = LOW	0



## Digital multistandard TV decoder

SAA9051

**Table 32** Source select (pin and subaddress)

CONTROL BIT	PIN	SUBADDRESS
AFCC	68	09, D2
SS3	25	0A, D4
SS2	24	0A, D3
SS1	66	09, D1
SS0	65	09, D0

SUBADDRESS 0A

**Table 33** Disabling of HSY and HC pulses (system mode dependent)

FUNCTION	CONTROL BIT SYC (SA0A, D7)
HSY and HC output pulses disabled	1
HSY and HC output pulses enabled	0

**Table 34** Chrominance input/output 3-state control

FUNCTION	CONTROL BIT CT (SA0A, D6)
CVBS output active	1
output HIGH-impedance Z-state	0

**Table 35** Chrominance source select

FUNCTION	CONTROL BIT YC (SA0A, D5)
Y/C separate inputs	1
CVBS input	0

**Table 36** Variable delay compensation of the luminance path (YDL0 - YDL2 control the luminance delay in order to compensate different chrominance delays throughout the system)

DELAY (N =)	CONTROL BITS (SA0A, D2 .. D0)		
	YDL2	YDL1	YDL0
0	0	0	0
+1	0	0	1
+2	0	1	0
+3	0	1	1
-4	1	0	0
-3	1	0	1
-2	1	1	0
-1	1	1	1

**Notes to Table 36**

- The delay is given in terms of clock cycles:
- $13.5 \text{ MHz} = N \times 74 \text{ ns}$ .

## Digital multistandard TV decoder

SAA9051

## SUBADDRESS 0B

Table 37 SECAM chrominance delay compensation (system mode dependent)

PROGRAMMABLE DELAY*	CONTROL BITS						
	SCDC6	SCDC5	SCDC4	SCDC3	SCDC2	SCDC1	SCDC0
0	0	0	0	0	0	0	0
1	0	0	0	0	0	0	1
2	0	0	0	0	0	1	0
.	.	.	.	.	.	.	.
4	0	0	0	0	1	0	0
.	.	.	.	.	.	.	.
8	0	0	0	1	0	0	0
.	.	.	.	.	.	.	.
16	0	0	1	0	0	0	0
.	.	.	.	.	.	.	.
32	0	1	0	0	0	0	0
.	.	.	.	.	.	.	.
63	0	1	1	1	1	1	1
64	1	1	1	0	0	0	0
65	1	1	1	0	0	0	1
.	.	.	.	.	.	.	.
79	1	1	1	1	1	1	1
<b>Maximum delay selected by single control bit</b>							
	16	32	16	8	4	2	1

## Notes to Table 37

- \* = Delay in number of LL3 clock cycles.
- SA0B, D7 don't care.

## Digital multistandard TV decoder

SAA9051

## SLAVE TRANSMITTER ORGANIZATION

## Slave transmitter format

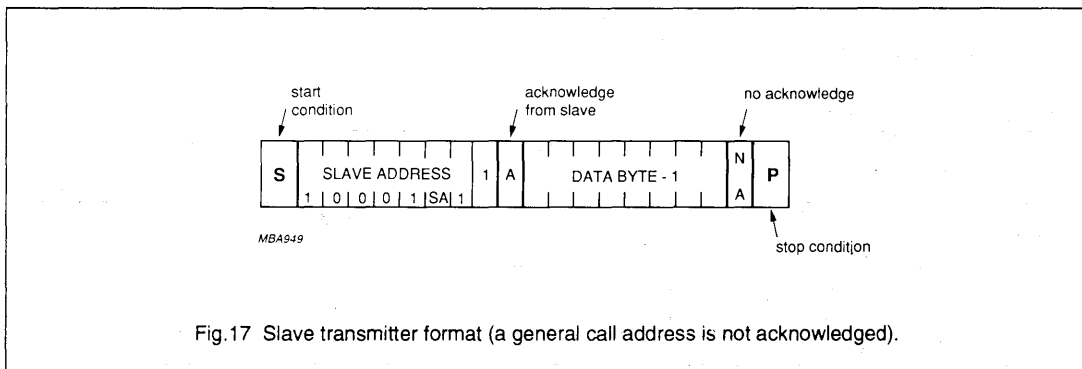

Fig.17 Slave transmitter format (a general call address is not acknowledged).

The format of data byte 1 is:

Table 38

D7	D6	D5	D4	D3	D2	D1	D0
PONRES	HLOCK	1	FD	0	CD	CS	0

Data bits D0, D3 and D5 are fixed in slave transmitter byte.

Table 39 Description of data byte 1

BIT	DESCRIPTION
PONRES	Status bit for power-on-reset ( $\overline{RES}$ ) and after a power failure. logic 1 after the first power-on-reset and after a power failure. Also set to logic 1 after a severe voltage dip that may have disturbed slave receiver data in the PAL/NTSC decoder (SAA9051). PONRES sets all data bits of control registers 1 and 2 to zero. logic 0 after a successful read of the PAL/NTSC decoder status byte
HLOCK	Status bit for horizontal frequency lock (transmitter identification, stop or mute bit); logic 1 if horizontal frequency is not locked (no transmitter available); logic 0 if horizontal frequency is locked (transmitter received)
FD	Detected field frequency status bit: logic 1 when received signal has 60 Hz synchronization pulses; logic 0 when received signal has 50 Hz synchronization pulses
CD	PAL/NTSC colour-detected status bit: logic 1 when PAL/NTSC colour signal is detected; logic 0 when no PAL/NTSC colour signal is detected
CS	SECAM colour-detected status bit: logic 1 when SECAM colour signal is detected; logic 0 when no SECAM colour signal is detected.

## Digital multistandard TV decoder

SAA9051

**Default coefficients set for the S-DMSD and SAA9056**

The default coefficients are set for operation with the TDA8703 or TDA8708, these devices are

analog-to-digital converters. The 3-state outputs of the chrominance ADC are controlled by the SS3 switch in this example (all numbers are hex values).

The slave addresses are as follows:

- S-DMSD; 8A or 8E
- SAA9056; 8A or 8E

**Table 40** Slave address (SAA9051 part)

SUBADDRESS	FUNCTION	SHORT DELAY	LONG DELAY
00	inc. delay	5E	7E
01	HSY start	37	73
02	HSY stop	07	43
03	HC start	F6	32
04	HC stop	C7	03
05	HS start	FF	FF
06	H-peaking	02 (62 NTSC)	02 (62 NTSC)
07	HUE control	00	00
08	control 1	38 (77 NTSC)	38 (77 NTSC)
09	control 2	E3	E3 (D3 SECAM)
0A	control 3	58 (28 Y/C mode)	58 (28 Y/C mode)
0B	SECAM delay	00	3C

**Notes to Table 40**

1. Subaddress 05; application dependent.
2. Subaddress 08; HPLL is in the VTR mode. Hex value for TV mode is 18 (57 for NTSC).

**Table 41** Slave address (SAA9056 part)

SUBADDRESS	FUNCTION	VALUE
10	luminance delay	C0 - FF
11	BL delay	00
12	burst gate start	42
13	burst gate stop	56
14	sensitivity	20
15	filter	24
16	control	04 (02 active)

## Digital multistandard TV decoder

SAA9051

Table 42 Operating modes of the S-DMSD

INPUT	CT	YC	SS3	CE	SCDC	IDEL	YPN	BY	FS	ALT	CCFR1	CCFR0	REMARKS
<b>PAL B, G, H, I</b>													
CVBS	1 (0)	0	1 (0)	0	B (A)	B (A)	0	0	0	1	0	0	
Y/C	0	1	0	0	A	A	0 (1)	1	0	1	0	0	
<b>PAL M</b>													
CVBS	1 (0)	0	1 (0)	0	B (A)	B (A)	1	0	1	1	0	1	
Y/C	0	1	0	0	A	A	1 (0)	1	1	1	0	1	
<b>PAL N</b>													
CVBS	1 (0)	0	1 (0)	0	B (A)	B (A)	0	0	0	1	1	0	
Y/C	0	1	0	0	A	A	0 (1)	1	0	1	1	0	
<b>SECAM</b>													
CVBS	1	0 (1)	1	1	B	B	0	0	0	0 (1)	0 (1)	0 (1)	
Y/C	0	1 (0)	0	1	B	B	0 (1)	1	0	0 (1)	0 (1)	0 (1)	
<b>NTSC 4.43 MHz</b>													
CVBS	1 (0)	0	1 (0)	0	B (A)	B (A)	0	0	0	0	0	0	use FS = 1 for 60 Hz vertical frequency
Y/C	0	1	0	0	A	A	0 (1)	1	1	0	0	0	use FS = 1 for 60 Hz vertical frequency
<b>NTSC M</b>													
CVBS	1 (0)	0	1 (0)	0	B (A)	B (A)	1	0	1	0	1	1	
Y/C	0	1	0	0	A	A	1 (0)	1	1	0	1	1	

## Notes to Table 42

1. SS3 is assumed to control the 3-state output of the chrominance ADC (active LOW).
2. To avoid data collision care must be taken with the programming of CT and SS3 (in this equal they are always equal).

## Where:

A = short time delay.

B = long time delay.

Digital multistandard TV decoder

SAA9051

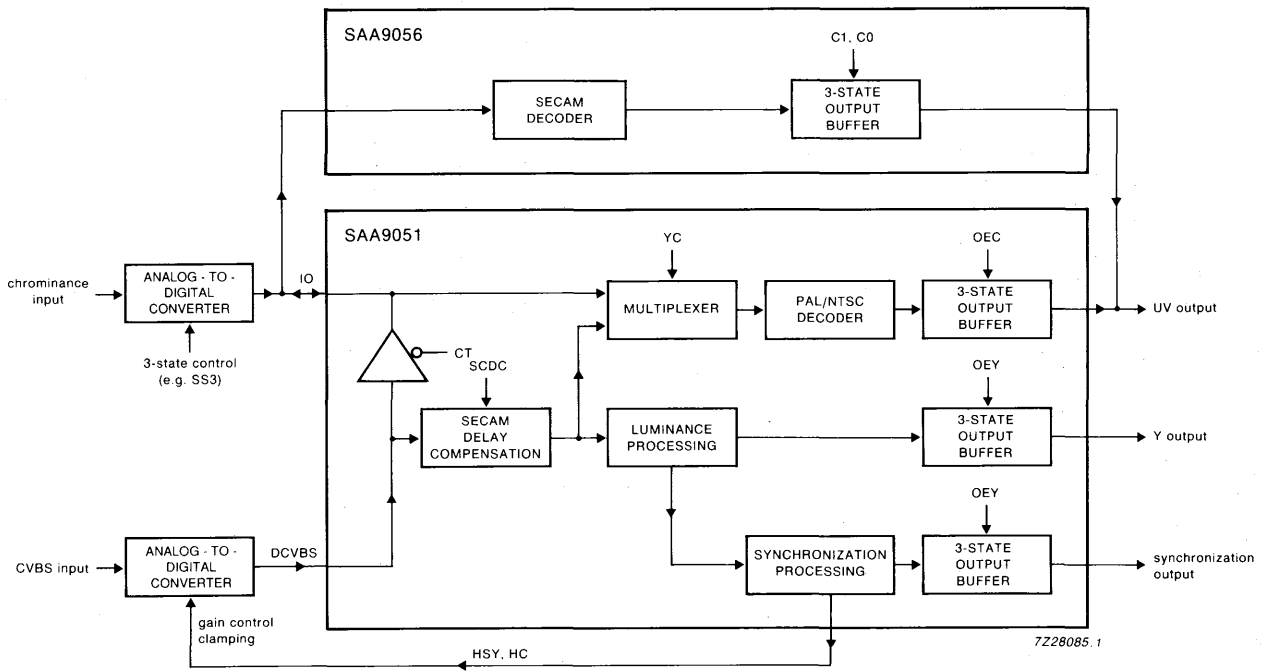

Fig.18 SAA9051 signal flow when used in conjunction with SAA9056.

Digital multistandard TV decoder

SAA9051

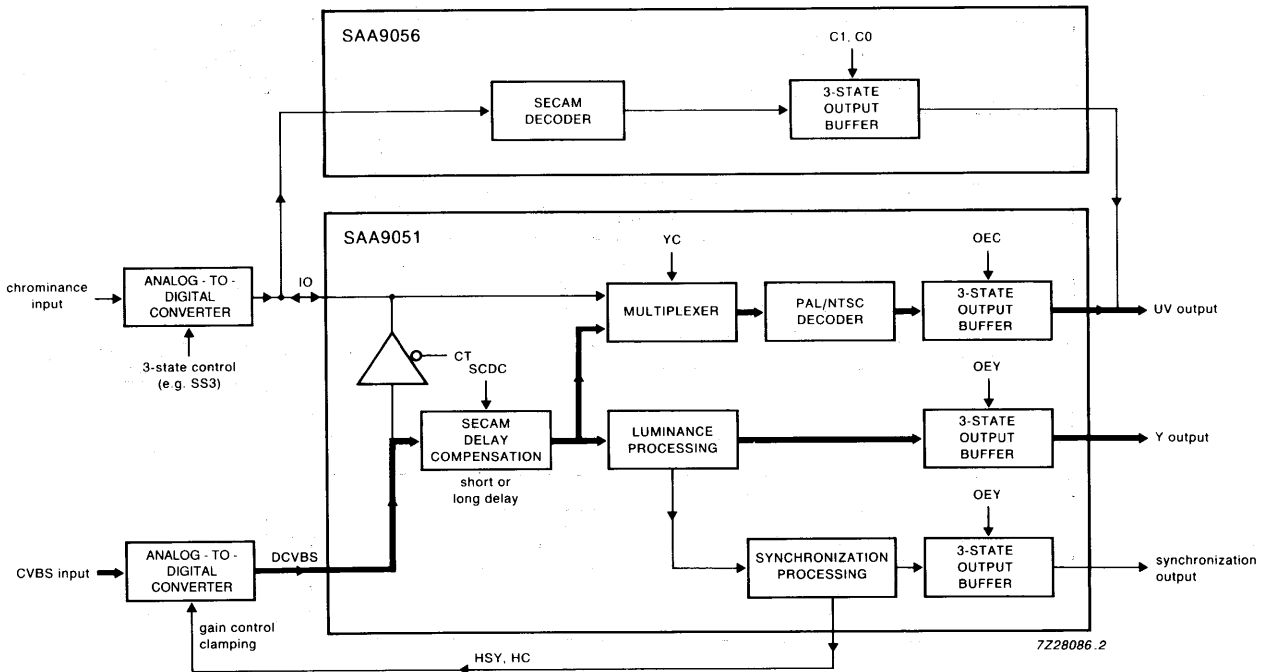

Fig.19 Signal flow - PAL or NTSC with CVBS input signal.

Digital multistandard TV decoder

SAA9051

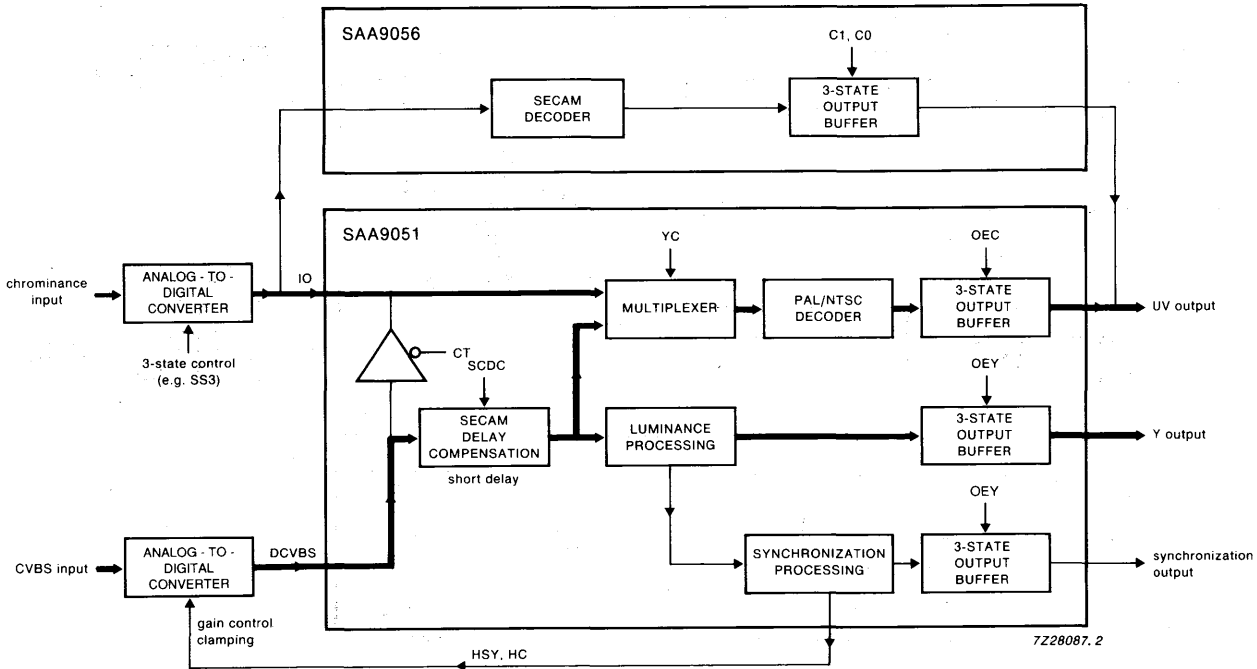

Fig.20 Signal flow - PAL or NTSC with Y/C input signal.



Digital multistandard TV decoder

SAA9051

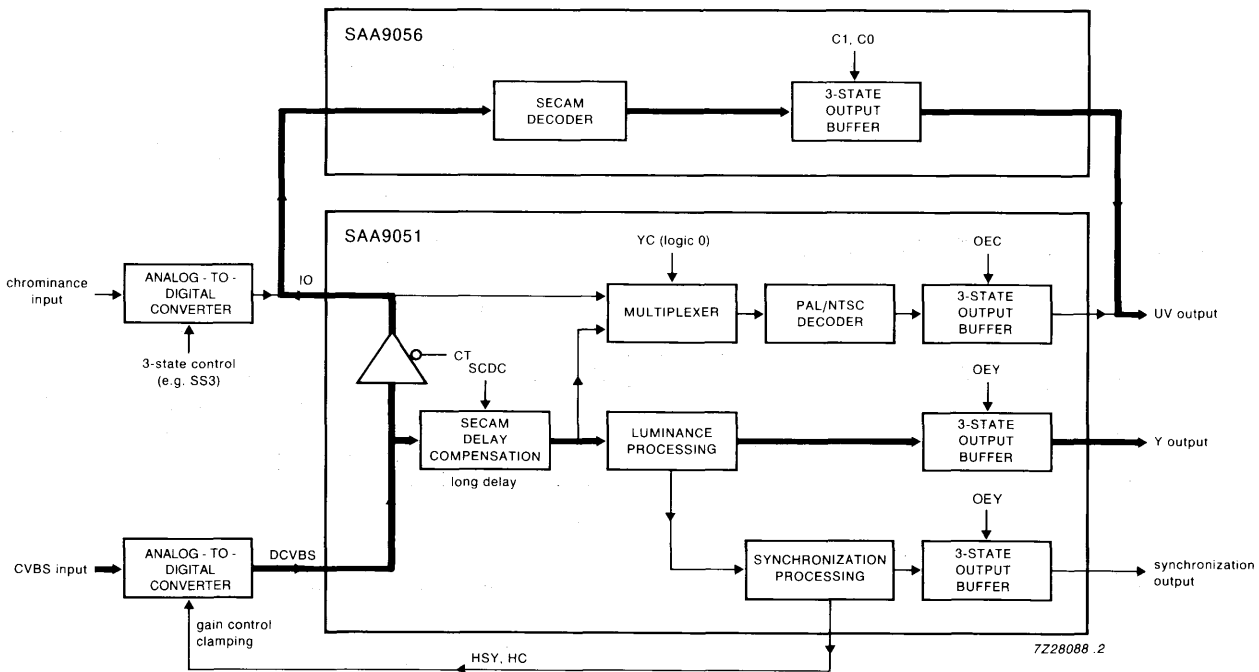

Fig.21 Signal flow - SECAM with CVBS input signal.

Digital multistandard TV decoder

SAA9051

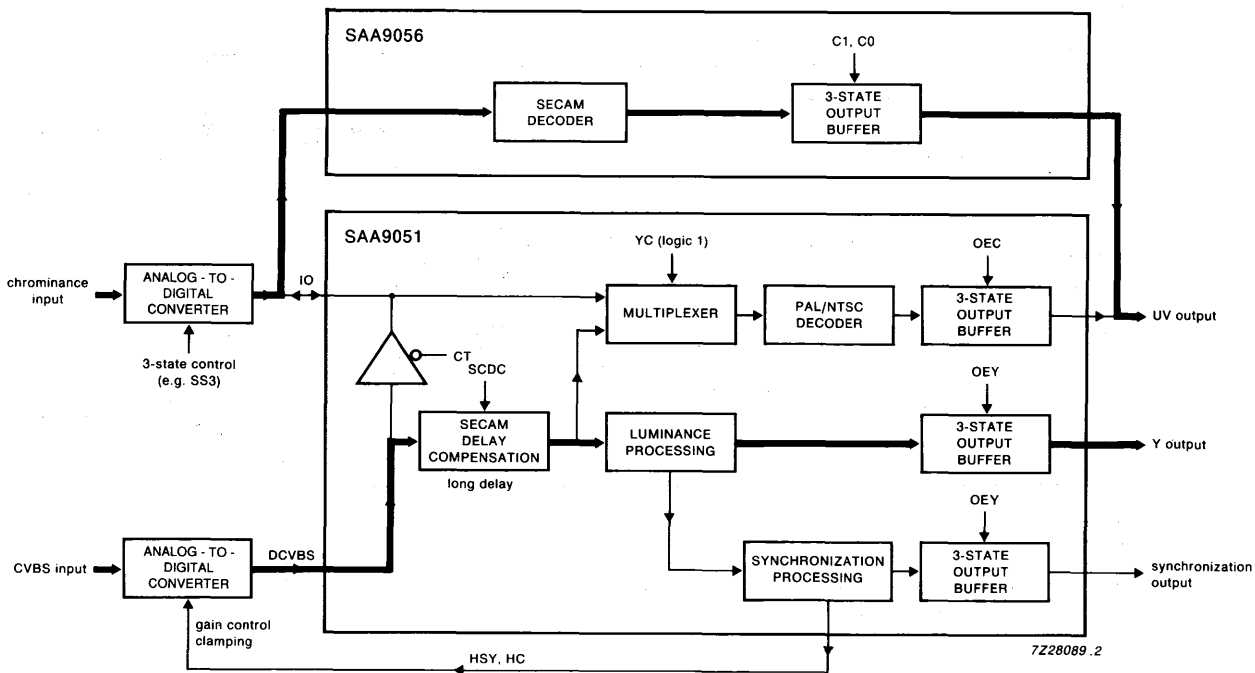

Fig.22 Signal flow - SECAM with Y/C input signal.

## Digital multistandard TV decoder

SAA9051

**LIMITING VALUES**

In accordance with the Absolute Maximum Rating System (IEC 134)

SYMBOL	PARAMETER	CONDITIONS	MIN.	MAX.	UNIT
V <sub>DD</sub>	supply voltage range		-0.5	+7	V
V <sub>I</sub>	input voltage range		-0.5	+7	V
V <sub>O</sub>	output voltage range	I <sub>Omax</sub> = 20 mA	-0.5	+7	V
P <sub>tot</sub>	maximum power dissipation per package		-	2750	mW
T <sub>amb</sub>	operating ambient temperature range		0	+70	°C
T <sub>stg</sub>	storage temperature range		-65	+150	°C

**HANDLING**

Inputs and outputs are protected against electrostatic discharge in normal handling. However, to be totally safe, it is good practice to take normal precautions appropriate to handling MOS devices (see 'Handling MOS Devices').

## Digital multistandard TV decoder

SAA9051

**CHARACTERISTICS** $V_{DD} = 4.5 \text{ V to } 5.5 \text{ V}$ ;  $T_{amb} = 0 \text{ to } +70 \text{ }^\circ\text{C}$ ; unless otherwise specified

SYMBOL	PARAMETER	CONDITION	MIN.	TYP.	MAX.	UNIT
<b>Supplies</b>						
$V_{DD}$	supply voltage		4.5	5	5.5	V
$I_{DD}$	supply current	note 1	-	370	500	mA
<b>Inputs</b>						
INPUT VOLTAGE LOW						
$V_{IL}$	pins 2 - 4, 6 - 17, 20 - 23, 33, 43, 56 and 64		-0.5	-	+0.8	V
$V_{IL}$	pins 40 and 41		-0.5	-	+1.5	V
INPUT VOLTAGE HIGH						
$V_{IH}$	pins 2 - 4, 6 - 17, 20 - 23, 43, 56 and 64		2	-	$V_{DD}$	V
$V_{IH}$	pins 33, 40 and 41		3	-	$V_{DD}$	V
INPUT LEAKAGE CURRENT						
$I_I$	pins 2 - 4, 6 - 17, 20 - 23, 40 - 41, 43 and 64		-	-	10	$\mu\text{A}$
INPUT CAPACITANCE						
$C_I$	pin 4		2	-	10	pF
$C_I$	pins 2 - 3, 14 - 17, 20 - 23, 43 and 64		2	-	7.5	pF
$C_I$	pins 6 - 13	HIGH-impedance Z-state	2	-	7.5	pF
<b>Outputs</b>						
OUTPUT VOLTAGE LOW						
$V_{OL}$	pins 6 - 13, 24 - 26, 29 - 32, 42, 45 - 50, 53, 55 - 58, 65 - 66 and 68	$I_{OL} = 2.0 \text{ mA}$	0	-	0.6	V
$V_{OL}$	pins 40 and 41	$I_{OL} = 5.0 \text{ mA}$	0	-	0.45	V
OUTPUT VOLTAGE HIGH						
$V_{OH}$	pins 6 - 13, 24 - 26, 29 - 32, 42, 45 - 50, 53, 55 - 58, 65 - 66 and 68	$I_{OH} = -0.5 \text{ mA}$	2.2	-	$V_{DD}$	V
OUTPUT CAPACITANCE						
$C_O$	pins 45 - 50, 53 and 55 - 58		-	-	7.5	pF
LFCO OUTPUT (NOTE 2)						
$V_{\alpha(P-P)}$	output voltage (peak-to-peak value)	$R_L \geq 10 \text{ k}\Omega$ ; $C_L < 15 \text{ pF}$	1.0	-	-	V
$V_{\alpha(P-P)}$	output voltage (peak-to-peak value)	$R_L \geq 1 \text{ k}\Omega$ ; $C_L < 15 \text{ pF}$	0.5	-	-	V
<b>Timing (see Fig.23)</b>						
$t_{C3}$	LL3 cycle time		69	-	80	ns
$t_{C3H}/t_{C3}$	LL3 duty factor		43	-	57	%
$t_r, t_f$	LL3 rise and fall times	note 3	-	-	6	ns
$t_{SU, DAT}$	input data set-up time		12	-	-	ns

## Digital multistandard TV decoder

SAA9051

SYMBOL	PARAMETER	CONDITION	MIN.	TYP.	MAX.	UNIT
<b>Timing (see Fig.23)</b>						
$t_{HD\_DAT}$	input data hold time		5	-	-	ns
$t_{HD}$	output data hold time		5	-	-	ns
$t_D$	output data delay time	except HSY and HC; $C_L = 25$ pF; $I_{OL} = 2.0$ mA; $V_{OH} = 2.2$ V	-	-	50	ns
$t_D$	HSY and HC output delay time	$C_L = 25$ pF; $I_{OL} = 2.0$ mA; $V_{OH} = 2.6$ V	-	-	80	ns
$C_L$	output data load capacitance		7.5	-	25	pF
<b>Crystal oscillator (see Fig.20)</b>						
$f_n$	nominal frequency	third harmonic	-	24.576	-	MHz
$\Delta f/f_n$	permissible deviation of $f_n$		-	$\pm 50 \times 10^{-6}$	-	
$\Delta T/f_n$	temperature deviation from $f_n$		-	$\pm 20 \times 10^{-6}$	-	
$T_{XTAL}$	temperature range		0	-	+70	°C
$C_{LXTAL}$	load capacitance		8	-	-	pF
$R_r$	maximum resonance resistance		-	40	80	$\Omega$
$C_1$	motional capacitance		-	$1.5 \pm 20\%$	-	fF
$C_0$	parallel capacitance		-	$3.5 \pm 20\%$	-	pF

**Notes to the characteristics**

- Inputs LOW and outputs not connected,  $V_{DD} = 5$  V.
- 4-bit triangular waveform clocked at 24.576 MHz, AC coupled at pin 36.
- Rising and falling edges of the clock signal are assumed to be smooth e.g. due to roll-off low-pass filtering.



Purchase of Philips' I<sup>2</sup>C components conveys a license under the Philips' I<sup>2</sup>C patent to use the components in the I<sup>2</sup>C-system provided the system conforms to the I<sup>2</sup>C specifications defined by Philips.

Digital multistandard TV decoder

SAA9051

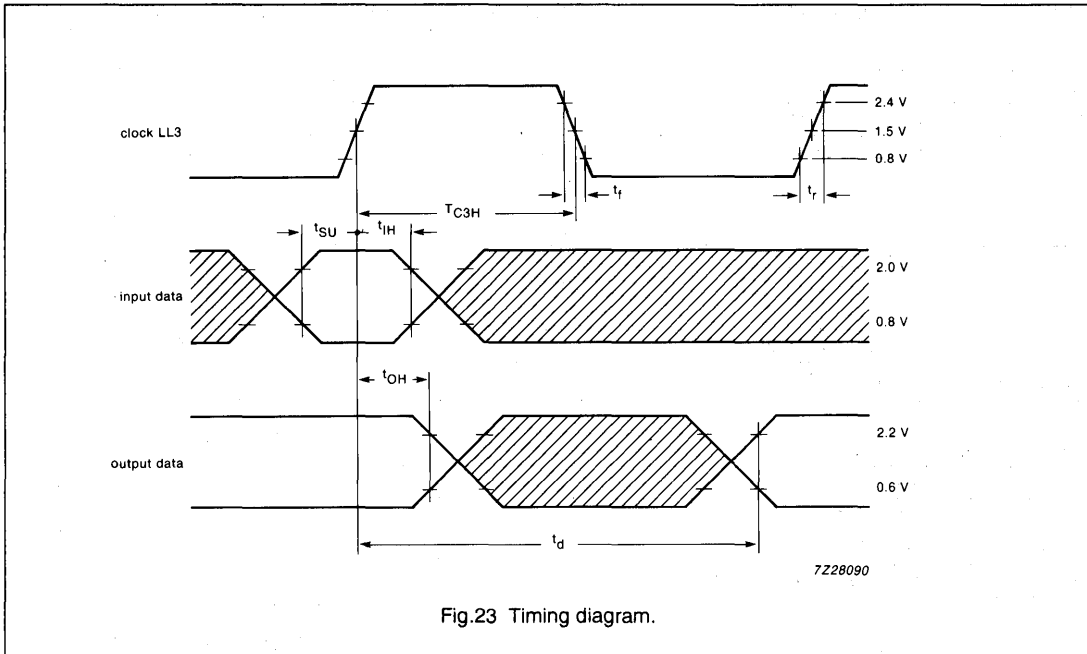

Fig.23 Timing diagram.

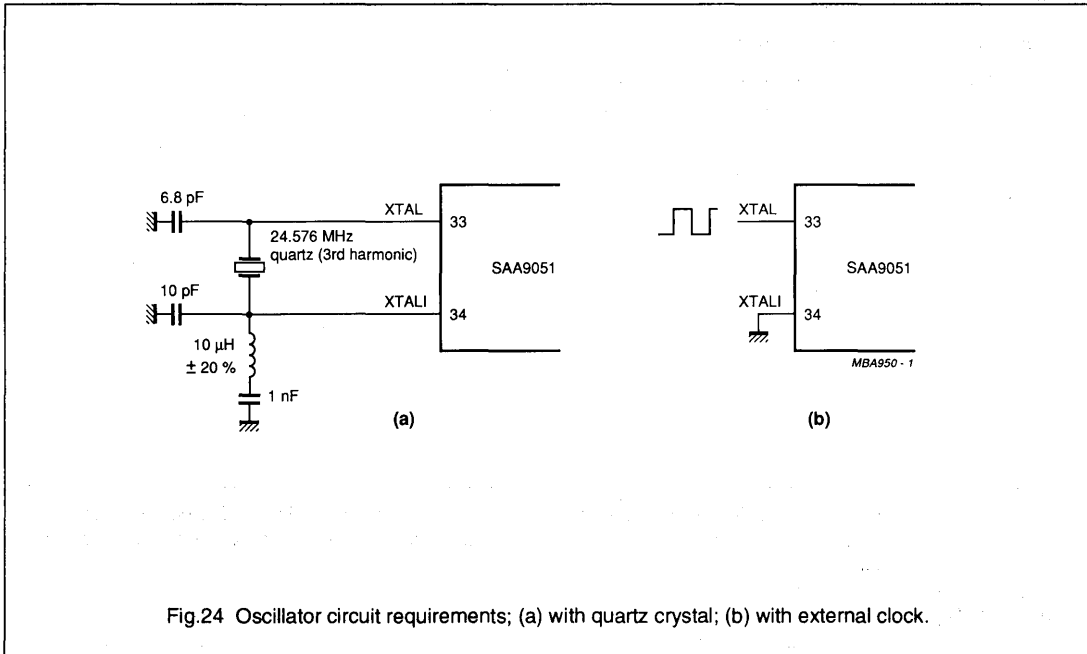

Fig.24 Oscillator circuit requirements; (a) with quartz crystal; (b) with external clock.

# Clock signal generator circuit for Digital TV systems (CGC)

SAA9057B

## FEATURES

- Clock generation suitable for digital TV systems (line-locked)
- PLL frequency multiplier to generate 4 times of input frequency
- Dividers to generate clocks LL1.5, LL3 and LL3T (4th and 2nd multiples of input frequency)
- Reset control and power fail detection

## QUICK REFERENCE DATA

SYMBOL	PARAMETER	MIN.	TYP.	MAX.	UNIT
$V_{DDA}$	analog supply voltage (pin 5)	4.5	5.0	5.5	V
$V_{DDD}$	digital supply voltage (pins 8, 17)	4.5	5.0	5.5	V
$I_{DDA}$	analog supply current	3	-	9	mA
$I_{DDD}$	digital supply current	10	-	40	mA
$V_{LFCO}$	LFCO input voltage (peak-to-peak value)	1	-	$V_{DDA}$	V
$f_i$	input frequency range	6.25	-	7.25	MHz
$V_I$	input voltage LOW	0	-	0.8	V
	input voltage HIGH	2.4	-	$V_{DDD}$	V
$V_O$	output voltage LOW	0	-	0.6	V
	output voltage HIGH	2.6	-	$V_{DDD}$	V
$T_{amb}$	operating ambient temperature range	0	-	70	°C

## GENERAL DESCRIPTION

The SAA9057B generates all clock signals required for a digital TV system suitable for the SAA90xx family. Optional extras (feature box etc.) can be driven via external buffers, advantageous for a digital TV system based on display standard conversion concepts.

## ORDERING INFORMATION

EXTENDED TYPE NUMBER	PACKAGE			
	PINS	PIN POSITION	MATERIAL	CODE
SAA9057B	20	DIL	plastic	SOT146
SAA9057BT	20	mini-pack (SO20)	plastic	SOT163A

# Clock signal generator circuit for digital TV systems (CGC)

SAA9057B

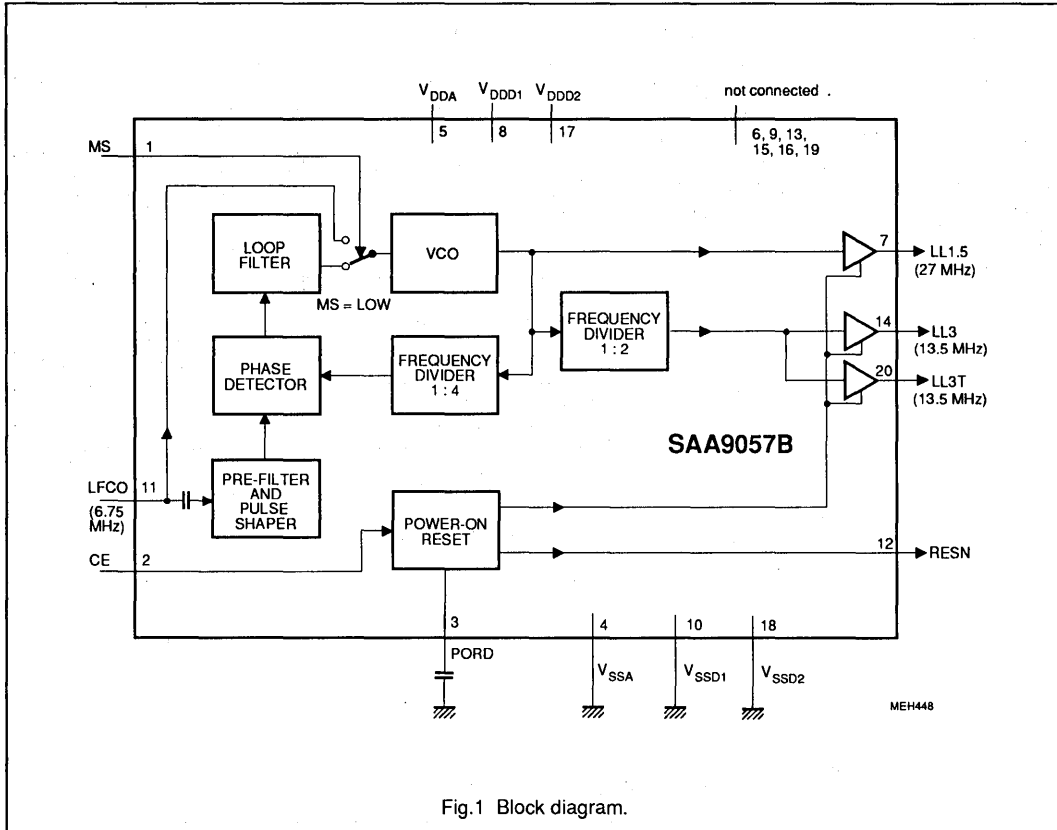

Fig.1 Block diagram.

## FUNCTION DESCRIPTION

The SAA9057B generates all clock signals required for a digital TV system suitable for the SAA90xx family. Optional extras (feature box etc.) can be driven via external buffers, advantageous for a digital TV system based on display standard conversion concepts. The 6.75 MHz input signal LFCO, coming from SAA 9051, is multiplied to 27 MHz by the PLL (including phase detector, loop filter, VCO and frequency divider) and output on LL1.5 (pin7). 13.5 MHz frequency is also generated by 1:2 divider and output on LL3 and LL3T (pins 14

and 20).

The rectangular output signals have 50 % duty factor.

### Mode select MS

The LFCO input signal is directly connected to the VCO at MS = HIGH. The circuit operates as an oscillator and frequency divider. MS function is not tested.

### Chip enable CE

The buffer outputs are enabled and power-on reset is set to HIGH by CE = HIGH (Fig.4). CE = LOW sets the clock outputs HIGH and RESN output LOW.

### Power-on reset

Power-on reset is activated at power-on, when the supply voltage decreases below 3.5 V (Fig.4) or when chip enable is done. The indicator output RESN is LOW for a time determined by capacitor on pin 3. The RESN signal can be applied to reset other circuit of this digital TV system.

The LFCO input signal has to be applied before RESN becomes HIGH.



# Clock signal generator circuit for digital TV systems (CGC)

## SAA9057B

### PINNING

SYMBOL	PIN	DESCRIPTION
MS	1	mode select input (LOW = PLL mode)
CE	2	chip enable /reset (HIGH = outputs enabled)
PORD	3	power-on reset delay dependent on external capacitor
V <sub>SSA</sub>	4	analog ground (0 V)
V <sub>DDA</sub>	5	analog supply voltage (+5 V)
n.c.	6	not connected
LL1.5	7	line-locked clock output signal (4 times $f_{LFCO}$ )
V <sub>DDD1</sub>	8	digital supply voltage 1 (+5 V)
n.c.	9	not connected
V <sub>SSD1</sub>	10	digital ground 1 (0 V)
LFCO	11	line-locked input frequency
RESN	12	reset output (active-LOW)
n.c.	13	not connected
LL3	14	line-locked clock output signal (2 times $f_{LFCO}$ )
n.c.	15	not connected
n.c.	16	not connected
V <sub>DDD2</sub>	17	digital supply voltage 2 (+5 V)
V <sub>SSD2</sub>	18	digital ground 2 (0 V)
n.c.	19	not connected
LL3T	20	line-locked clock output signal (2 times $f_{LFCO}$ )

### PIN CONFIGURATION

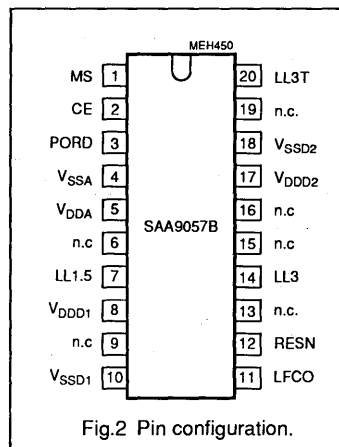

### LIMITING VALUES

In accordance with the Absolute Maximum Rating System (IEC 134).

SYMBOL	PARAMETER	MIN.	MAX.	UNIT
V <sub>DDA</sub>	analog supply voltage (pin 5)	-0.5	7.0	V
V <sub>DDD</sub>	digital supply voltage (pins 8 and 17)	-0.5	7.0	V
V <sub>diff GND</sub>	difference voltage V <sub>DDA</sub> - V <sub>DDD</sub>	-	±100	mV
V <sub>O</sub>	output voltage (I <sub>OM</sub> = 20 mA)	-0.5	V <sub>DDD</sub>	V
P <sub>tot</sub>	total power dissipation	0	1.1	W
T <sub>stg</sub>	storage temperature range	-65	150	°C
T <sub>amb</sub>	operating ambient temperature range	0	70	°C
V <sub>ESD</sub>	electrostatic handling* for all pins	-	tbf	V

\* Inputs and outputs are protected against electrostatic discharge in normal handling. However, to be totally safe, it is recommended to take normal handling precautions appropriate to "Handling MOS devices".

# Clock signal generator circuit for digital TV systems (CGC)

SAA9057B

**CHARACTERISTICS**
 $V_{DDA} = V_{DDD} = 4.5$  to  $5.5$  V;  $f_{LFCO} = 6.25$  to  $7.25$  MHz and  $T_{amb} = 0$  to  $70$  °C unless otherwise specified.

SYMBOL	PARAMETER	CONDITIONS	MIN.	TYP.	MAX.	UNIT
$V_{DDA}$	analog supply voltage (pin 5)		4.5	5.0	5.5	V
$V_{DDD}$	digital supply voltage (pins 8 and 17)		4.5	5.0	5.5	V
$I_{DDA}$	analog supply current (pin 5)		3	-	9	mA
$I_{DDD}$	digital supply current ( $I_8 + I_{17}$ )	note 1	10	-	40	mA
$V_{reset}$	power-on reset threshold voltage	Fig.4	-	3.5	-	V
<b>Input LFCO (pin 11)</b>						
$V_{11}$	DC input voltage		0	-	$V_{DDA}$	V
$V_i$	input signal (peak-to-peak value)		1	-	$V_{DDA}$	V
$f_{LFCO}$	input frequency range		6.25	-	7.25	MHz
$C_{11}$	input capacitance		-	-	10	pF
<b>Inputs MS and CE (pins 1 and 2)</b>						
$V_{IL}$	input voltage LOW		0	-	0.8	V
$V_{IH}$	input voltage HIGH		2.0	-	$V_{DDD}$	V
$I_{LI}$	input leakage current		-	-	10	$\mu$ A
$C_i$	input capacitance		-	-	5	pF
<b>Output RESN (pin 12)</b>						
$V_{OL}$	output voltage LOW	$I_{OL} = 2$ mA	0	-	0.4	V
$V_{OH}$	output voltage HIGH	$I_{OH} = -0.5$ mA	2.4	-	$V_{DDD}$	V
$I_{LI}$	output leakage current		-	-	$\pm 10$	$\mu$ A
$t_d$	RESN delay time	$C_3 = 0.1$ $\mu$ F; Fig.4	20	-	200	ms
<b>Output signals LL1.5, LL3 and LL3T (pins 7, 14 and 20)</b>						
$V_{OL}$	output voltage LOW	$I_{OL} = 2$ mA	0	-	0.6	V
$V_{OH}$	output voltage HIGH	$I_{OH} = -0.5$ mA	2.6	-	$V_{DDD}$	V
$I_{LI}$	output leakage current	high-impedance	-	-	$\pm 10$	$\mu$ A
$t_{comp}$	composite rise time	note 1; note 2	-	-	9	ns
$f_{LL}$	output frequency LL1.5	Figures 3 and 6	-	$4 f_{LFCO}$	-	MHz
	output frequency LL3		-	$2 f_{LFCO}$	-	MHz
	output frequency LL3T		-	$2 f_{LFCO}$	-	MHz
$t_{LL}$	duty factor LL1.5	note 1; Fig.3	40	50	60	%
	duty factor LL3 and LL3T	note 1; Fig.3	43	50	57	%
$t_r, t_f$	rise and fall times	note 1; Fig.3	-	-	6	ns

# Clock signal generator circuit for digital TV systems (CGC)

SAA9057B

### Notes to the characteristics

1.  $f_{LFCO} = 7.0$  MHz and output load 40 pF. VSSA and VSSD short connected together.
2.  $t_{comp}$  is the rise time from LOW of all clocks to HIGH of all clocks (Fig.3) including rise time, skew and jitter components. Measurements taken between 0.6 V and 2.6 V.
3. MS function is not tested.

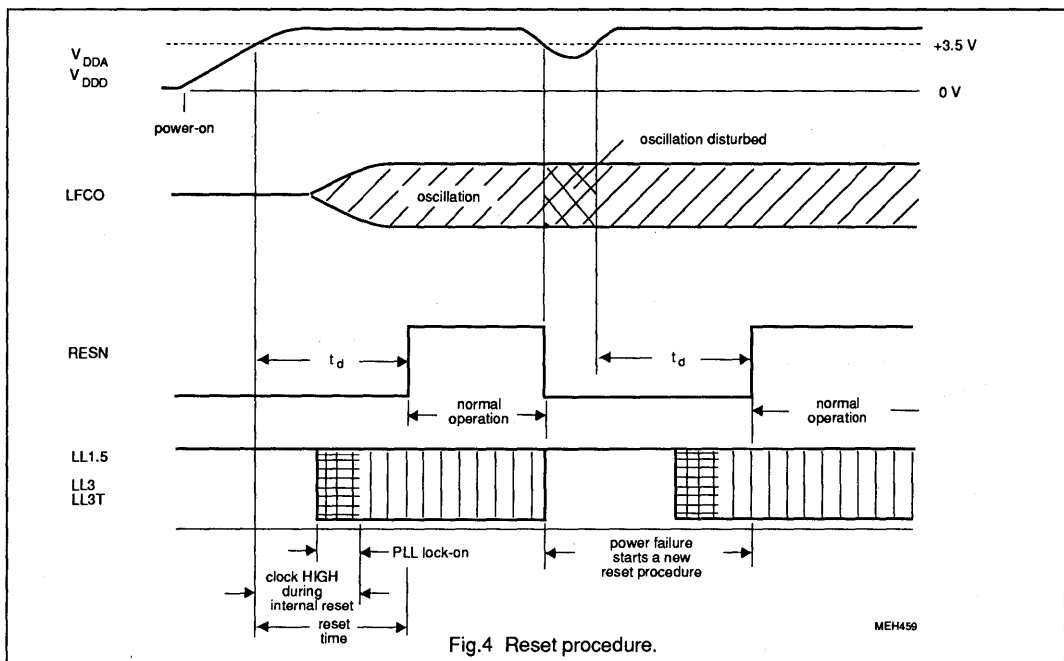
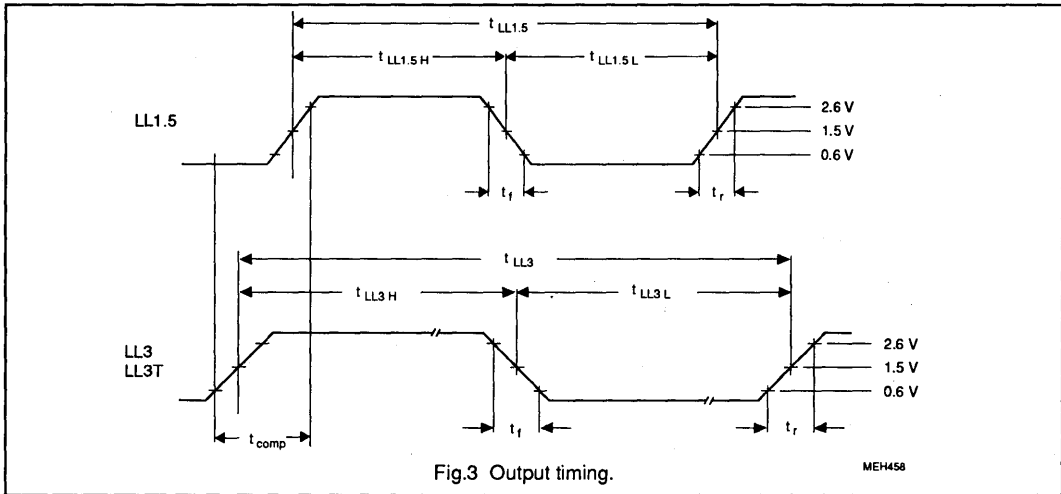

# Clock signal generator circuit for digital TV systems (CGC)

SAA9057B

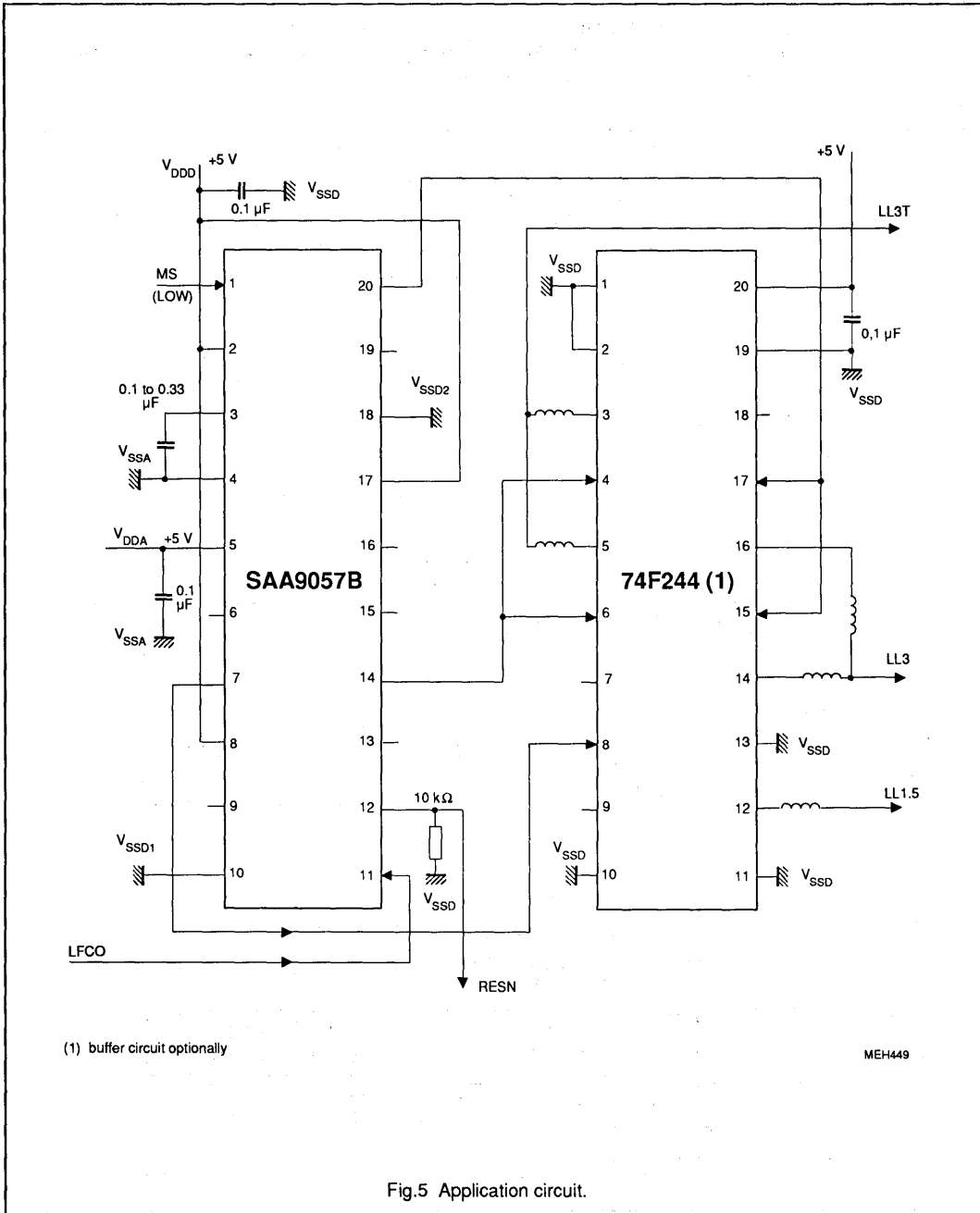
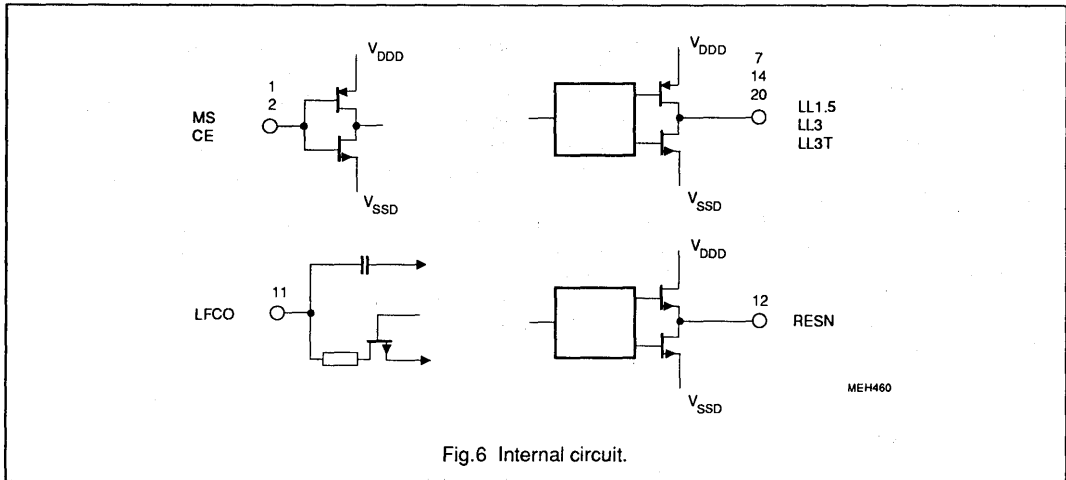

Fig.5 Application circuit.

# Clock signal generator circuit for digital TV systems (CGC)

SAA9057B



# Video enhancement and D/A processor (VEDA)

SAA9065

## 1. FEATURES

- CMOS circuit to enhance video data and to convert luminance and colour-difference signals from digital-to-analog
- 16-bit parallel input for 4:1:1 and 4:2:2 YUV data
- Data clock input LLC (line-locked clock) for a data rate up to 30 MHz
- 8-bit luminance and 8-bit multiplexed colour-difference formats (optional 7-bit formats)
- MC input to support various clock and pixel rates
- Formatter for YUV input data; 4:2:2 format, 4:1:1 format and filter characteristics selectable
- HREF input to determine the active line (number of pixels)
- Controllable peaking of luminance signal
- Coring stage with controllable threshold to eliminate noise in luminance signal
- Interpolation filter suitable for both formats to increase the data rate in chrominance path
- Polarity of colour-difference signals selectable
- Separate digital-to-analog converters (9-bit resolution for Y; 8-bit for colour-difference signals)
- 1 V (p-p)/ 75  $\Omega$  outputs realized by two resistors
- No external adjustments
- All functions controlled via I<sup>2</sup>C-bus

## 2. QUICK REFERENCE DATA

SYMBOL	PARAMETER	MIN.	TYP.	MAX.	UNIT
V <sub>DD</sub>	supply voltage digital part	4.5	5	5.5	V
V <sub>DDA</sub>	supply voltage analog part	4.75	5	5.25	V
I <sub>DD</sub>	total supply current	-	tof	-	mA
V <sub>IL</sub>	input voltage LOW on YUV-bus	-0.5	-	0.8	V
V <sub>IH</sub>	input voltage HIGH on YUV-bus	2	-	V <sub>DD</sub> +0.5	V
f <sub>LLC</sub>	input data rate	-	-	30	MHz
V <sub>o Y,CD</sub>	output signal Y, $\pm(R-Y)$ and $\pm(B-Y)$ (peak-to-peak value)	-	2	-	V
R <sub>L Y,CD</sub>	output load resistance	125	-	-	$\Omega$
ILE	DC integral linearity error in output signal (8-bit data)	-	-	1	LSB
DLE	DC differential error in output signal (8-bit data)	-	-	0.5	LSB
T <sub>amb</sub>	operating ambient temperature range	0	-	70	$^{\circ}\text{C}$

## 3. ORDERING INFORMATION

EXTENDED TYPE NUMBER	PACKAGE			
	PINS	PIN POSITION	MATERIAL	CODE
SAA9065	44	PLCC	plastic	SOT187

4. BLOCK DIAGRAM

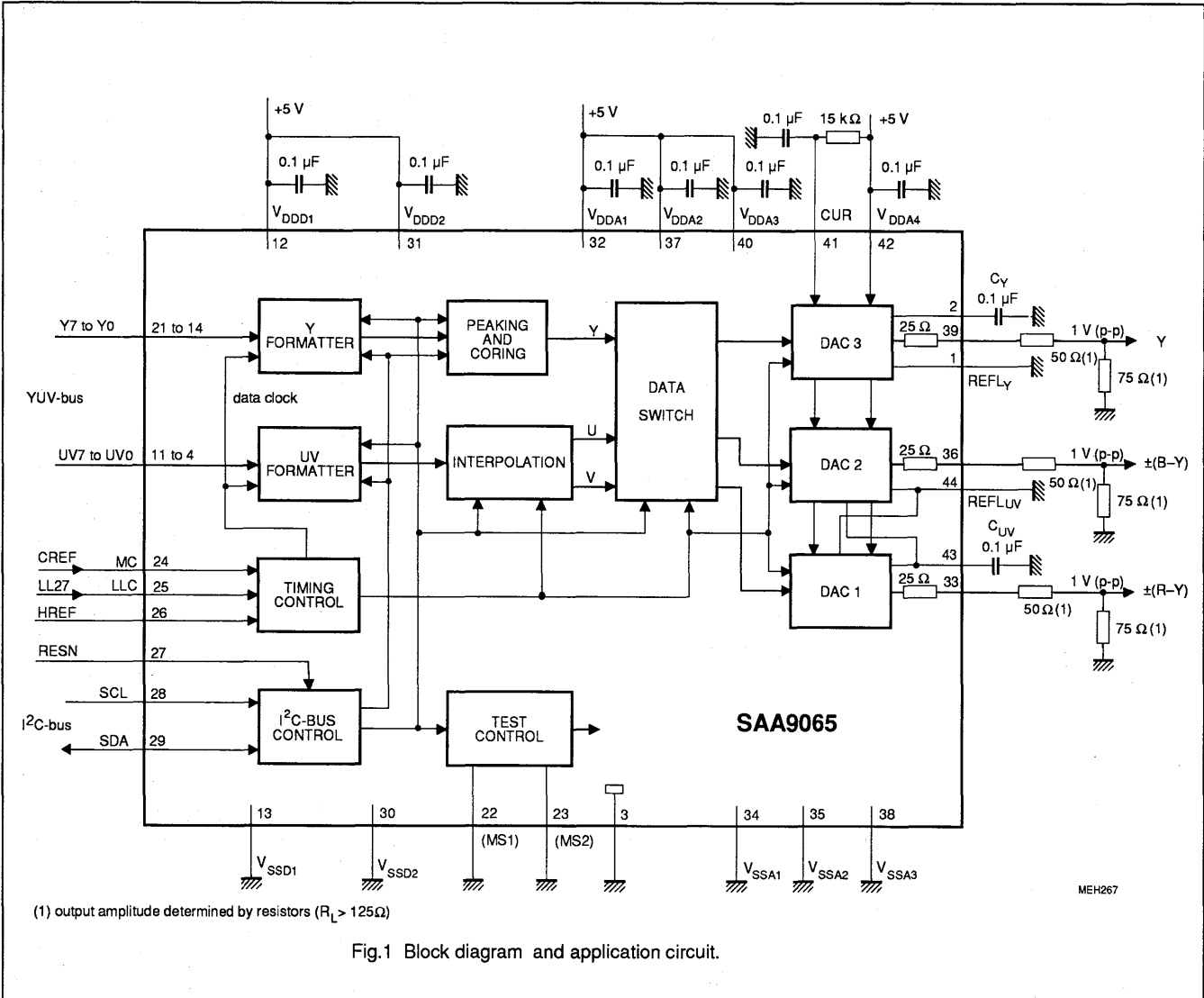

Fig.1 Block diagram and application circuit.

# Video enhancement and D/A processor (VEDA)

SAA9065

## 5. PINNING

SYMBOL	PIN	DESCRIPTION
REFLY	1	low reference of luminance DAC (connected to $V_{SSA1}$ )
$C_Y$	2	capacitor for luminance DAC (high reference)
SUB	3	substrate (connected to $V_{SSA1}$ )
UVO	4	UV signal input bits UV7 to UVO (digital colour-difference signal)
UV1	5	
UV2	6	
UV3	7	
UV4	8	
UV5	9	
UV6	10	
UV7	11	
$V_{DD1}$	12	+5 V digital supply voltage 1
$V_{SS1}$	13	digital ground 1 (0 V)
Y0	14	Y signal input bits Y7 to Y0 (digital luminance signal)
Y1	15	
Y2	16	
Y3	17	
Y4	18	
Y5	19	
Y6	20	
Y7	21	
MS2	22	mode select 2 input for testing chip
MS1	23	mode select 1 input for testing chip
MC	24	data clock CREF (13.5 MHz e. g.); at MC = HIGH the LLC divider-by-two is inactive
LLC	25	line-locked clock signal (LL27 = 27 MHz)
HREF	26	data clock for YUV data inputs (for active line 768Y or 640Y long)
RESN	27	reset input (active LOW)
SCL	28	I <sup>2</sup> C-bus clock line
SDA	29	I <sup>2</sup> C-bus data line
$V_{SS2}$	30	digital ground 2 (0 V)
$V_{DD2}$	31	+5 V digital supply voltage 2
$V_{DA1}$	32	+5 V analog supply voltage for buffer of DAC 1
(R-Y)	33	$\pm$ (R-Y) output signal (analog signal)
$V_{SSA1}$	34	analog ground 1 (0 V)



# Video enhancement and D/A processor (VEDA)

## SAA9065

SYMBOL	PIN	DESCRIPTION
V <sub>SSA2</sub>	35	analog ground 2 (0 V)
(B-Y)	36	±(B-Y) output signal (analog colour-difference signal)
V <sub>DDA2</sub>	37	+5 V analog supply voltage for buffer of DAC 2
V <sub>SSA3</sub>	38	analog ground 3 (0 V)
Y	39	Y output signal (analog luminance signal)
V <sub>DDA3</sub>	40	+5 V analog supply voltage for buffer of DAC 3
CUR	41	current input for analog output buffers
V <sub>DDA4</sub>	42	supply and reference voltage for the three DACs
C <sub>UV</sub>	43	capacitor for chrominance DACs (high reference)
REFL <sub>UV</sub>	44	low reference of chrominance DACs (connected to V <sub>SSA1</sub> )

### PIN CONFIGURATION

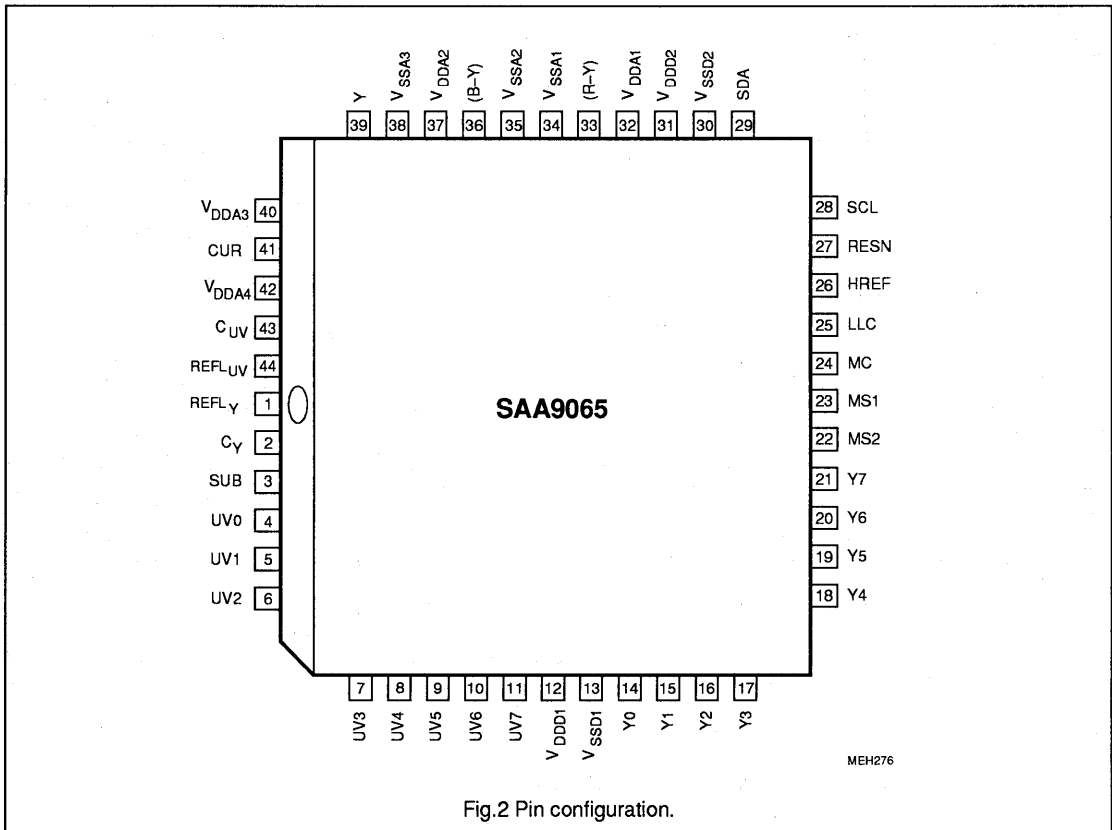

Fig.2 Pin configuration.

# Video enhancement and D/A processor (VEDA)

## SAA9065

### 6. FUNCTIONAL DESCRIPTION

The CMOS circuit SAA9065 processes digital YUV-bus data up to a data rate of 30 MHz. The data inputs Y7 to Y0 and UV7 to UV0 (Fig.1) are provided with 8-bit data. The data of digital colour-difference signals U and V are in a multiplexed state (serial in 4:2:2 or 4:1:1 format; Tables 2 and 3).

Data is read with the rising edge of LLC (line-locked clock) to achieve a data rate of LLC at MC = HIGH only. If MC is supplied with the frequency CREF (LLC/2 for example), data is read only at every second rising edge (Fig.3). The 7-bit YUV input data are also supported by means of the R78-bit (R78 = 0). Additionally, the luminance data format is converted for internal use into a two's complement format by inverting MSB. The Y input byte (bits Y7 to Y0) represent luminance information; the UV input byte (bits UV7 to UV0) one of the two digital colour-difference signals in 4:2:2 format (Table 2).

**Table 1** LLC and MC configuration modes in DMSD applications

PIN	INPUT SIGNAL	COMMENT
LLC MC	LLC (LL27) CREF	The data rate on YUV-bus is half the clock rate on pin LLC, e. g. in SAA7151B, SAA7191 and SAA7191B single scan operation.
LLC MC	LLC (LL27) MC = HIGH	The data rate on YUV-bus must be identical to the clock rate on pin LLC, e. g. in double scan applications.
LLC MC	LLC2/LL3 MC = HIGH	The data rate on YUV-bus must be identical to the clock rate on pin LLC, e. g. SAA9051 single scan operation.
Note: YUV data are only latched with the rising edge of LLC at MC = HIGH.		

The HREF input signal (HREF = HIGH) determines the start and the end of an active line (Fig.3) the number of pixels respectively. The analog output Y is blanked at HREF = LOW, the (B-Y) and (R-Y) outputs are in a colourless state. The blanking level can be set by the BLV-bit. The SAA9065 is controllable via the I<sup>2</sup>C-bus.

#### Y and UV formatters

The input data formats are formatted into the internally used processing formats (separate for 4:2:2 and 4:1:1 formats). The IFF, IFC and IFL bits control the input data format and determine the right interpolation filter (Figures 10 to 13).

#### Peaking and coring

Peaking is applied to the Y signal to compensate several bandwidth reductions of the external pre-processing. Y signals can be improved to obtain a better sharpness.

There are the two switchable bandpass filters BF1 and BF 2

controlled via the I<sup>2</sup>C-bus by the bits BP1, BP0 and BFB. Thus, a frequency response is achieved in combination with the peaking factor K (Figures 5 to 9; K is determined by the bits BFB, WG1 and WG0).

The coring stage with controllable threshold (4 states controlled by CO1 and CO0 bits) reduces noise disturbances (generated by the bandpass gain) by suppressing the amplitude of small high-frequent signal components. The remaining high-frequent peaking component is available for a weighted addition after coring.

**Table 2** Data format 4 : 2 : 2. (Fig.3)

INPUT	PIXEL BYTE SEQUENCE					
Y0 (LSB)	Y0	Y0	Y0	Y0	Y0	Y0
Y1	Y1	Y1	Y1	Y1	Y1	Y1
Y2	Y2	Y2	Y2	Y2	Y2	Y2
Y3	Y3	Y3	Y3	Y3	Y3	Y3
Y4	Y4	Y4	Y4	Y4	Y4	Y4
Y5	Y5	Y5	Y5	Y5	Y5	Y5
Y6	Y6	Y6	Y6	Y6	Y6	Y6
Y7 (MSB)	Y7	Y7	Y7	Y7	Y7	Y7
UV0 (LSB)	U0	V0	U0	V0	U0	V0
UV1	U1	V1	U1	V1	U1	V1
UV2	U2	V2	U2	V2	U2	V2
UV3	U3	V3	U3	V3	U3	V3
UV4	U4	V4	U4	V4	U4	V4
UV5	U5	V5	U5	V5	U5	V5
UV6	U6	V6	U6	V6	U6	V6
UV7 (MSB)	U7	V7	U7	V7	U7	V7
Y frame	0	1	2	3	4	5
UV frame	0		2		4	

## Video enhancement and D/A processor (VEDA)

SAA9065

### Interpolation

The chrominance interpolation filter consists of various filter stages, multiplexers and de-multiplexers to increase the data rate of the colour-difference signals by a factor of 2 or 4. The switching of the filters by the bits IFF, IFC and IFL is described previously. Additional signal samples with significant amplitudes between two consecutive signal samples of the low data rate are generated. The time-multiplexed U and V samples are stored in parallel for converting.

### Data switch

The digital signals are adapted to the conversation range. U and V data have 8-bit formats again; Y can have 9 bits dependent on peaking. Blanking and switching to colourless level is applied here. Bits can be inverted by INV-bit to change the polarity of colour-difference output signals.

### Digital-to-analog converters

Conversion is separate for Y, U and V. The converters use resistor chains with low-impedance output buffers. The minimum output voltage is 200 mV to reduce integral

non-linearity errors. The analog signal, without load on output pin, is between 0.2 and 2.2 V floating. An application for 1 V/75  $\Omega$  on outputs is shown in Fig.1.

Each digital-to-analog converter has its own supply and ground pins suitable for decoupling. The reference voltage, supplying the resistor chain of all three DACs, is the supply voltage  $V_{DDA4}$ . The current into pin 41 is 0.3 mA; a larger current improves the bandwidth but increases the integral non-linearity.

Table 3 Data format 4 : 1 : 1

INPUT	PIXEL BYTE SEQUENCE							
Y0	Y0	Y0	Y0	Y0	Y0	Y0	Y0	Y0
Y1	Y1	Y1	Y1	Y1	Y1	Y1	Y1	Y1
Y2	Y2	Y2	Y2	Y2	Y2	Y2	Y2	Y2
Y3	Y3	Y3	Y3	Y3	Y3	Y3	Y3	Y3
Y4	Y4	Y4	Y4	Y4	Y4	Y4	Y4	Y4
Y5	Y5	Y5	Y5	Y5	Y5	Y5	Y5	Y5
Y6	Y6	Y6	Y6	Y6	Y6	Y6	Y6	Y6
Y7	Y7	Y7	Y7	Y7	Y7	Y7	Y7	Y7
UV0	0	0	0	0	0	0	0	0
UV1	0	0	0	0	0	0	0	0
UV2	0	0	0	0	0	0	0	0
UV3	0	0	0	0	0	0	0	0
UV4	V6	V4	V2	V0	V6	V4	V2	V0
UV5	V7	V5	V3	V1	V7	V5	V3	V1
UV6	U6	U4	U2	U0	U6	U4	U2	U0
UV7	U7	U5	U3	U1	U7	U5	U3	U1
Y frame	0	1	2	3	4	5	6	7
UV frame	0				4			

# Video enhancement and D/A processor (VEDA)

## SAA9065

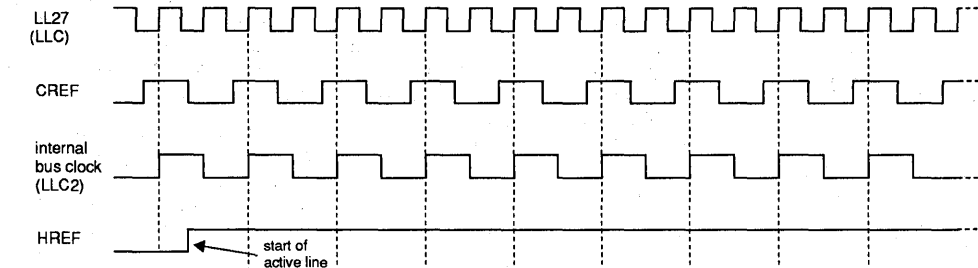

Byte numbers for pixels:

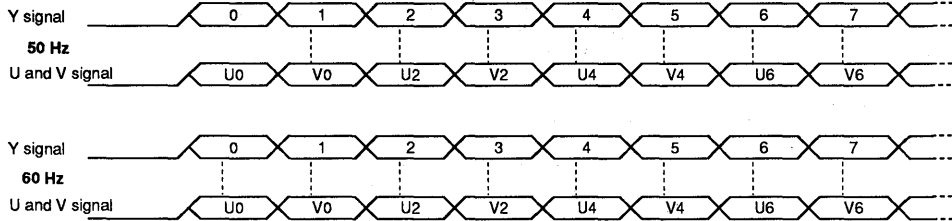

MEH268

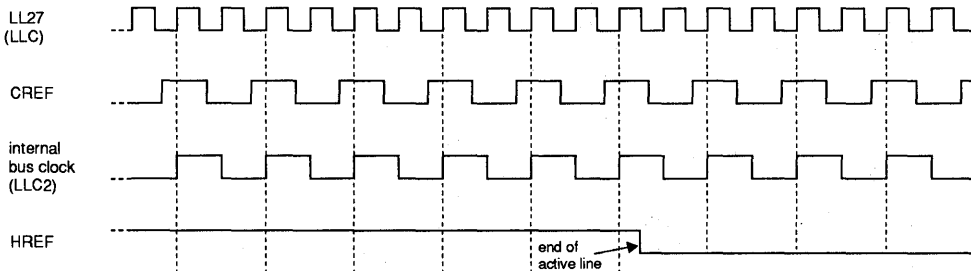

Byte number for pixels:

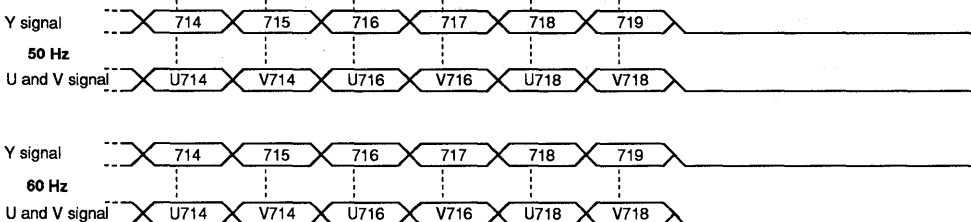

MEH269

Fig.3 Line control by HREF for 4 : 2 : 2 format, CREF = 13.5 MHz; HREF = 720 pixel;  
50 Hz and 60 Hz field.

## Video enhancement and D/A processor (VEDA)

SAA9065

### 7. LIMITING VALUES

In accordance with the Absolute Maximum Rating System (IEC 134).

SYMBOL	PARAMETER	MIN.	MAX.	UNIT
V <sub>DD1</sub>	supply voltage range (pin 12)	-0.3	7	V
V <sub>DD2</sub>	supply voltage range (pin 31)	-0.3	7	V
V <sub>DDA1</sub>	supply voltage range (pin 32)	-0.3	7	V
V <sub>DDA2</sub>	supply voltage range (pin 37)	-0.3	7	V
V <sub>DDA3</sub>	supply voltage range (pin 40)	-0.3	7	V
V <sub>DDA4</sub>	supply voltage range (pin 42)	-0.3	7	V
V <sub>diff GND</sub>	difference voltage V <sub>SSD</sub> - V <sub>SSA</sub>	-	±100	mV
V <sub>n</sub>	voltage on all input pins 4 to 11, 14 to 27 and 41	-0.3	V <sub>DD</sub>	V
V <sub>n</sub>	voltage on analog output pins 33, 36 and 39	-0.3	V <sub>DD</sub>	V
P <sub>tot</sub>	total power dissipation	0	tbf	mW
T <sub>stg</sub>	storage temperature range	-55	150	°C
T <sub>amb</sub>	operating ambient temperature range	0	70	°C
V <sub>ESD</sub>	electrostatic handling* for all pins	±2000	-	V

\* Equivalent to discharging a 100 pF capacitor through a 1.5 kΩ series resistor.

### 8. THERMAL RESISTANCE

SYMBOL	PARAMETER	THERMAL RESISTANCE
R <sub>th j-a</sub>	from junction-to-ambient in free air	46 K/W

# Video enhancement and D/A processor (VEDA)

## SAA9065

### 9. CHARACTERISTICS

$V_{DD} = 4.5$  to  $5.5$  V;  $V_{DDA} = 4.75$  to  $5.25$  V; LLC = LL27; MC = CREF = 13.5 MHz;  $T_{amb} = 0$  to  $70$  °C; measurements taken in Fig.1 unless otherwise specified.

SYMBOL	PARAMETER	CONDITIONS	MIN.	TYP.	MAX.	UNIT
$V_{DD1}$	supply voltage range (pin 12)	for digital part	4.5	5	5.5	V
$V_{DD2}$	supply voltage range (pin 31)	for digital part	4.5	5	5.5	V
$V_{DDA1}$	supply voltage range (pin 32)	for buffer of DAC 1	4.75	5	5.25	V
$V_{DDA2}$	supply voltage range (pin 37)	for buffer of DAC 2	4.75	5	5.25	V
$V_{DDA3}$	supply voltage range (pin 40)	for buffer of DAC 3	4.75	5	5.25	V
$V_{DDA4}$	supply voltage range (pin 42)	DAC reference voltage	4.75	5	5.25	V
$I_{DDD}$	supply current ( $I_{DDD1} + I_{DDD2}$ )	for digital part	-	tbf	tbf	mA
$I_{DDA}$	supply current ( $I_{DDA1}$ to $I_{DDA4}$ )	for DACs and buffers	-	tbf	tbf	mA
<b>YUV-bus inputs</b> (pins 4 to 11 and 14 to 21)		Figures 3 and 4				
$V_{IL}$	input voltage LOW		-0.5	-	0.8	V
$V_{IH}$	input voltage HIGH		2.0	-	$V_{DD}+0.5$	V
$C_I$	input capacitance	$V_I = \text{HIGH}$	-	-	10	pF
$I_{LI}$	input leakage current		-	-	4.5	$\mu\text{A}$
<b>Inputs MS1, MS2, MC, LLC, HREF and RESN</b> (pins 22 to 27)						
$V_{IL}$	input voltage LOW		-0.5	-	0.8	V
$V_{IH}$	input voltage HIGH		2.0	-	$V_{DD}+0.5$	V
$C_I$	input capacitance	$V_I = \text{HIGH}$	-	-	10	pF
$I_{LI}$	input leakage current		-	-	4.5	$\mu\text{A}$
$V_{24}$	MC input voltage for LL27	27 MHz data rate	2.0	-	$V_{DD}+0.5$	V
	CREF signal on MC input	CREF data rate; note 1	-	-	-	V
<b>I<sup>2</sup>C-bus SCL and SDA</b> (pins 28 and 29)						
$V_{IL}$	input voltage LOW		-0.5	-	1.5	V
$V_{IH}$	input voltage HIGH		3.0	-	$V_{DD}+0.5$	V
$I_I$	input current	$V_I = \text{LOW or HIGH}$	-	-	$\pm 10$	$\mu\text{A}$
$V_{OL}$	SDA output voltage LOW (pin 29)	$I_{29} = 3$ mA	-	-	0.4	V
$I_{29}$	output current	during acknowledge	3	-	-	mA
<b>Digital-to-analog converters</b> (pins 1, 2, 41, 42, 43 and 44)						
$V_{DAC}$	input reference voltage for internal resistor chains (pin 42)		4.75	5	5.25	V
$I_{CUR}$	input current (pin 41)	$R_{41-42} = 15$ k $\Omega$	-	300	-	$\mu\text{A}$
$V_{1,44}$	reference voltage LOW	pin connected to $V_{SSA1}$	-	0	-	V
$C_L$	external blocking capacitor to $V_{SSA1}$ for reference voltage HIGH (pins 2 and 43)		-	0.1	-	$\mu\text{F}$

# Video enhancement and D/A processor (VEDA)

## SAA9065

SYMBOL	PARAMETER	CONDITIONS	MIN.	TYP.	MAX.	UNIT
$f_{LLC}$	data conversation rate (clock)	Fig.3	-	-	30	MHz
Res	resolution	luminance DAC	-	9	-	bit
		chrominance DACs	-	8	-	bit
ILE	DC integral linearity error	8-bit data	-	-	1.0	LSB
DLE	DC differential error	8-bit data	-	-	0.5	LSB
<b>Y, <math>\pm(R-Y)</math> and <math>\pm(B-Y)</math> analog outputs (pins 39, 33 and 36)</b>						
$V_o$	output signal voltage (peak-to-peak value)	without load	-	2	-	V
$V_{33,36,39}$	output voltage range	without load; note 2	0.2	-	2.2	V
$V_{39}$	output blanking level	Y output; note 3	-	16	-	LSB
$V_{33,36}$	output no-colour level	$\pm(R-Y)$ , $\pm(B-Y)$ ; note 4	-	128	-	LSB
$R_{33,36,39}$	internal serial output resistance		-	25	-	$\Omega$
$R_{L\ 33,36,39}$	output load resistance	external load	125	-	-	$\Omega$
B	output signal bandwidth	-3 dB	20	-	-	MHz
$t_d$	signal delay from input to Y output		-	tbf	-	ns
<b>LLC timing (pins 25)</b>			LLC; Fig.3			
$t_{LLC}$	cycle time		33	37	41	ns
$t_{pH}$	pulse width		40	50	60	%
$t_r$	rise time		-	-	5	ns
$t_f$	fall time		-	-	6	ns
<b>YUV-bus timing (pins 4 to 11 and 14 to 21)</b>			Fig.5			
$t_{SU}$	input data set-up time		11	-	-	ns
$t_{HD}$	input data hold time		3	-	-	ns
<b>MC timing (pin24)</b>			Fig.5			
$t_{SU}$	input data set-up time		11	-	-	ns
$t_{HD}$	input data hold time		3	-	-	ns
<b>RESN timing (pin 27)</b>						
$t_{SU}$	set-up time after power-on or failure	active LOW; note 5	$4 \times t_{LLC}$	-	-	ns

### Notes to the characteristics

1. YUV-bus data is read at MC = HIGH (pin 24) clocked with LLC (Fig.5) . Data is read only with every second rising edge of LLC when  $CREF = LLC/2$  on MC-pin 24.
2. 0.2 to 2.2 V output voltage range at 8-bit DAC input data. The data word can increase to 9-bit dependent on peaking factor.
3. The luminance signal is set to the digital black level: 16 LSB for BLV-bit = 0; 0 LSB for BLV-bit = 1.
4. The chrominance amplitudes are set to the digital colourless level of 128 LSB.
5. The circuit is prepared for a new data initialization.

**Video enhancement  
and D/A processor (VEDA)**

**SAA9065**

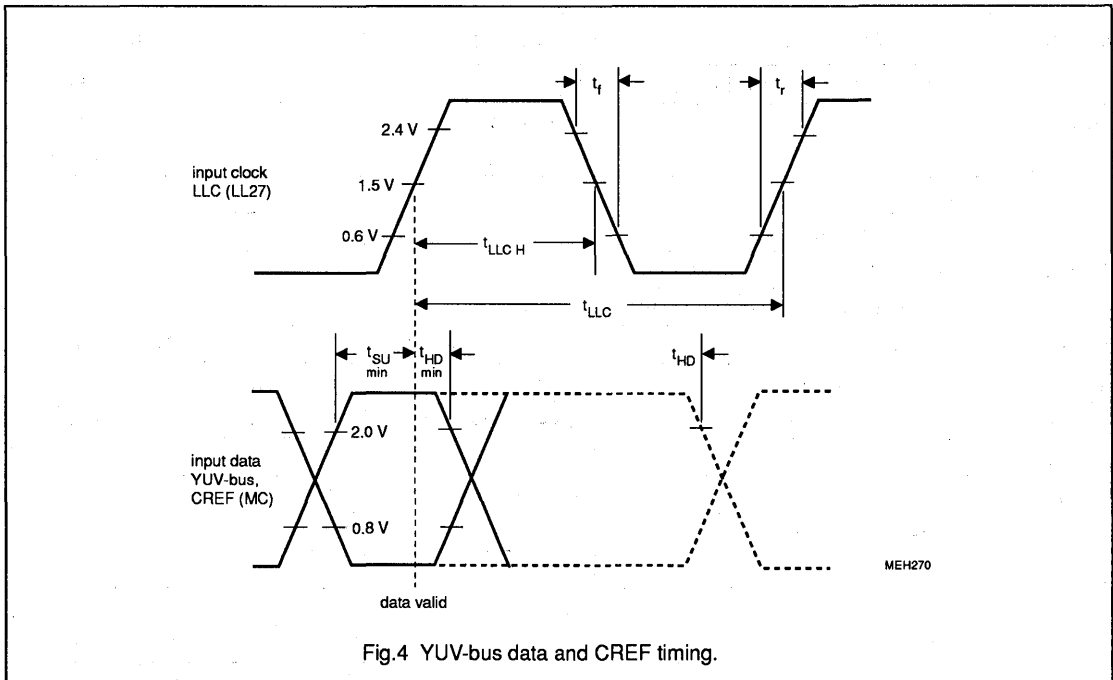

Fig.4 YUV-bus data and CREF timing.

PROCESSING DELAY	LLC CYCLES	REMARKS
YUV digital input to	44	at MC = "1"
YUV analog output	88	at MC = LLC/2



# Video enhancement and D/A processor (VEDA)

## SAA9065

### 10. I<sup>2</sup>C-BUS FORMAT

S	SLAVE ADDRESS	A	SUBADDRESS	A	DATA0	A		DATA <sub>n</sub>	A	P
---	---------------	---	------------	---	-------	---	--	-------------------	---	---

S	=	start condition
SLAVE ADDRESS	=	<b>1011 111X</b>
A	=	acknowledge, generated by the slave
SUBADDRESS*	=	subaddress byte (Table 4)
DATA	=	data byte (Table 4)
P	=	stop condition
X	=	read/write control bit
		X = 0, order to write (the circuit is slave receiver)
		X = 1, order to read (the circuit is slave transmitter)

\* If more than 1 byte DATA are transmitted, then auto-increment of the subaddress is performed.

**Table 4** I<sup>2</sup>C-bus transmission

FUNCTION	SUBADDRESS	DATA								
		D7	D6	D5	D4	D3	D2	D1	D0	
Peaking and coring	01	0	CO1	CO0	BP1	BP0	BFB	WG1	WG0	
Input formats; interpolation	02	IFF	IFC	IFL	0	0	0	0	0	
Input/output setting	03	0	0	0	0	DRP	BLV	R78	INV	

Bit functions in data bytes:					
CO1 to CO0	Control of coring threshold:	CO1	CO0		
		0	0	coring off	
		0	1	small noise reduction	
		1	0	medium noise reduction	
		1	1	high noise reduction	
BP1, BP0 and BFB	Bandpass filter selection:	BP1	BP0	BFB	
		0	0	0	characteristic Fig.5
		0	1	0	characteristic Fig.6
		1	0	0	characteristic Fig.7
		1	1	0	characteristic Fig.8
		0	0	1	BF1 filter bypassed Fig.9
		X	X	1	not recommended

# Video enhancement and D/A processor (VEDA)

## SAA9065

BFB, WG1 and WG0	Peaking factor K:	BFB	WG1	WG0	
		0	0	0	K = 1/8; minimum peaking
		0	0	1	K = 1/4
		0	1	0	K = 1/2
		0	1	1	K = 1; maximum peaking
		1	0	0	K = 0; peaking off
		1	0	1	K = 1/4; minimum peaking
		1	1	0	K = 1/2
		1	1	1	K = 1; maximum peaking
IFF, IFC, IFL	Input format and filter control at 13.5 MHz data rate:	IFF	IFC	IFL	
		0	0	0	4 : 1 : 1 format; -3 dB attenuation at 1.6 MHz video frequency; Fig.10
		0	0	1	4 : 1 : 1 format; -3 dB attenuation at 600 kHz video frequency; Fig.11
		0	1	0	4 : 1 : 1 format; -3 dB attenuation at 1.2 MHz video frequency; Fig.12
		1	0	0	4 : 2 : 2 format; -3 dB attenuation at 1.6 MHz video frequency; Fig.10
		1	0	1	4 : 2 : 2 format; -3 dB attenuation at 600 kHz video frequency; Fig.11
		1	1	X	4 : 2 : 2 format; -3 dB attenuation at 2.5 MHz video frequency; Fig.13
DRP	UV input data code:	0 = two's complement; 1 = offset binary			
BLV	Blanking level on Y output:	0 = 16 LSB; 1 = 0 LSB			
R78	YUV input data solution:	0 = 7-bit data; 1 = 8-bit data			
INV	Polarity of colour-difference output signals:	0 = normal polarity equal to input signal 1 = inverted polarity			

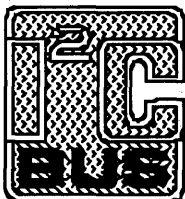

Purchase of Philips' I<sup>2</sup>C components conveys a license under the Philips' I<sup>2</sup>C patent to use the components in the I<sup>2</sup>C-system provided the system conforms to the I<sup>2</sup>C specifications defined by Philips.

# Video enhancement and D/A processor (VEDA)

## SAA9065

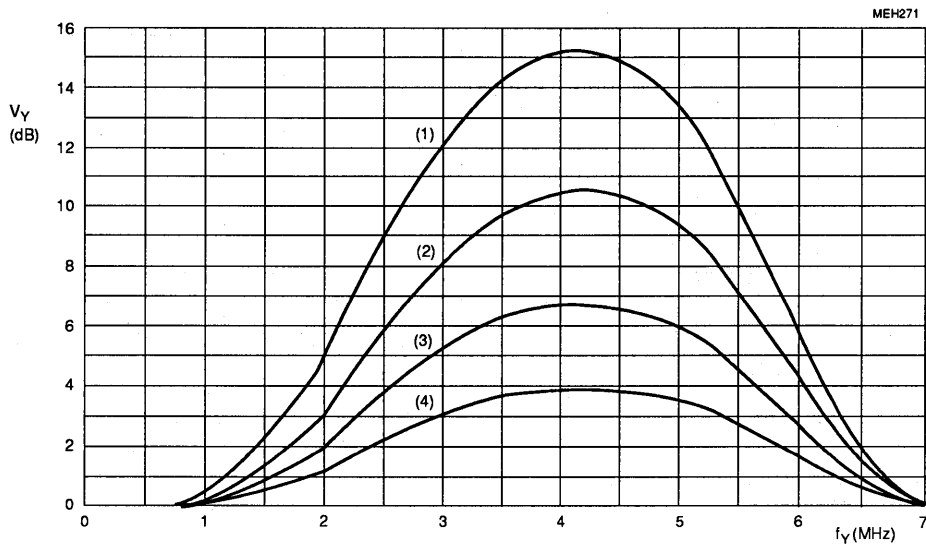

Fig. 5 Peaking frequency response with I<sup>2</sup>C-bus control bits BP1 = 0; BP0 = 0 and BFB = 0:  
(1) K = 1; (2) K = 1/2; (3) K = 1/4 and (4) K = 1/8.

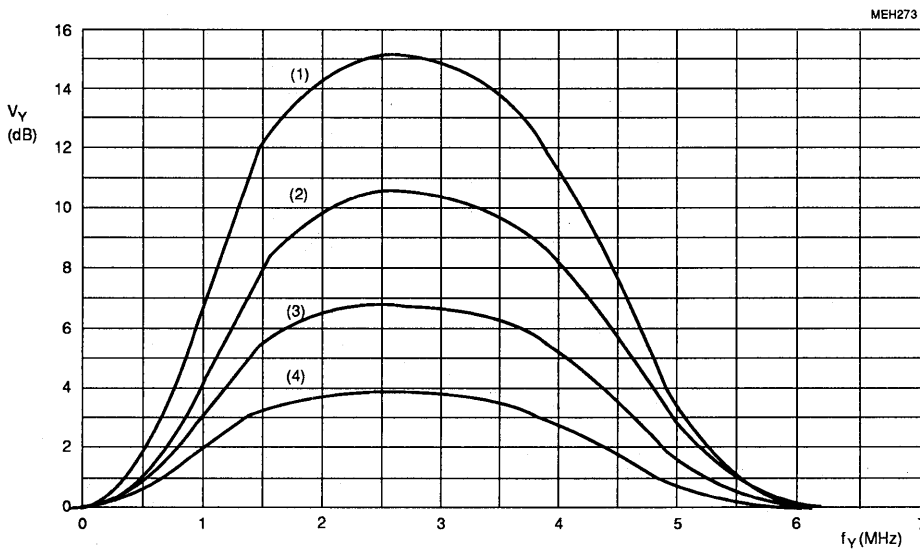
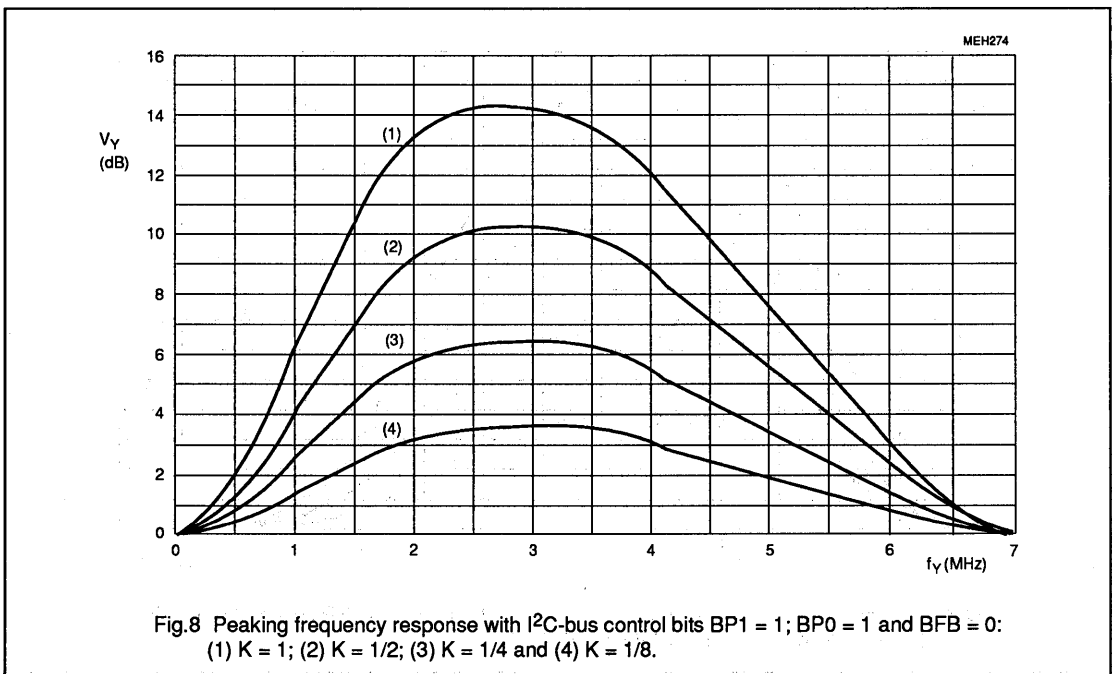
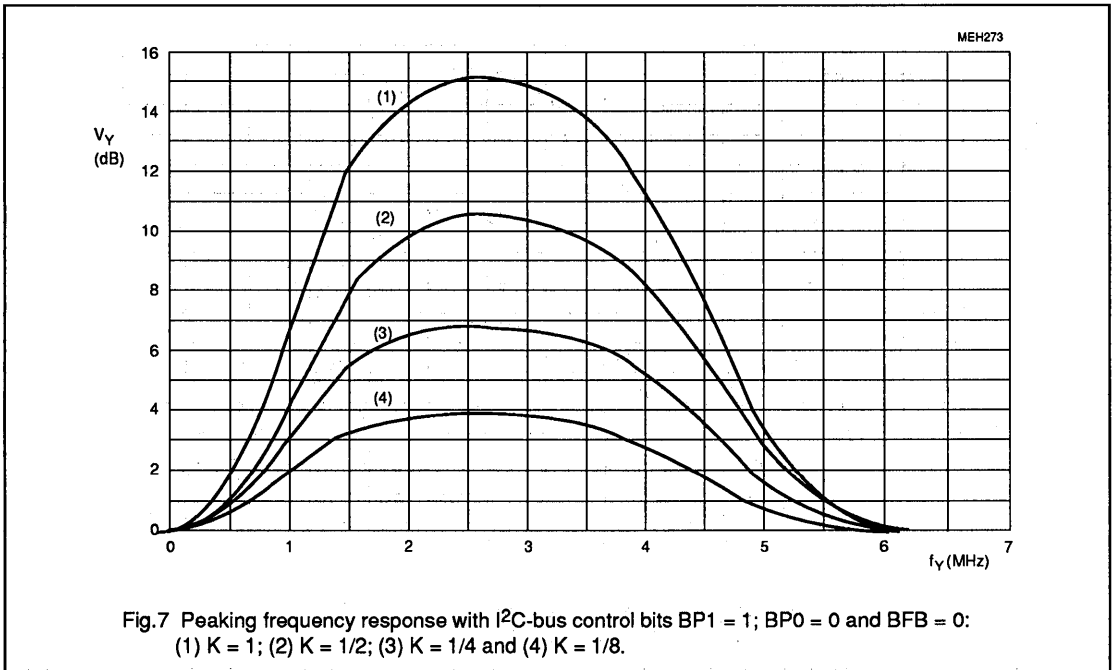

Fig. 6 Peaking frequency response with I<sup>2</sup>C-bus control bits BP1 = 0; BP0 = 1 and BFB = 0:  
(1) K = 1; (2) K = 1/2; (3) K = 1/4 and (4) K = 1/8.

# Video enhancement and D/A processor (VEDA)

## SAA9065



**Video enhancement  
and D/A processor (VEDA)****SAA9065**

Fig.9 Peaking frequency response with I<sup>2</sup>C-bus control bits BP1 = 0; BP0 = 0 and BFB = 1; bandpass filter BF1 bypassed and peaking off; (1) K = 1; (2) K = 1/2; (3) K = 1/4.

# Video enhancement and D/A processor (VEDA)

## SAA9065

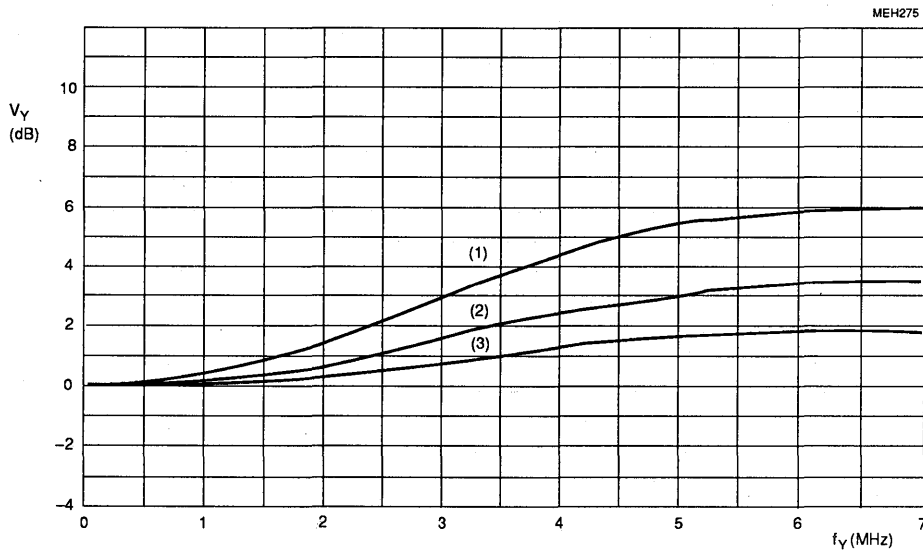
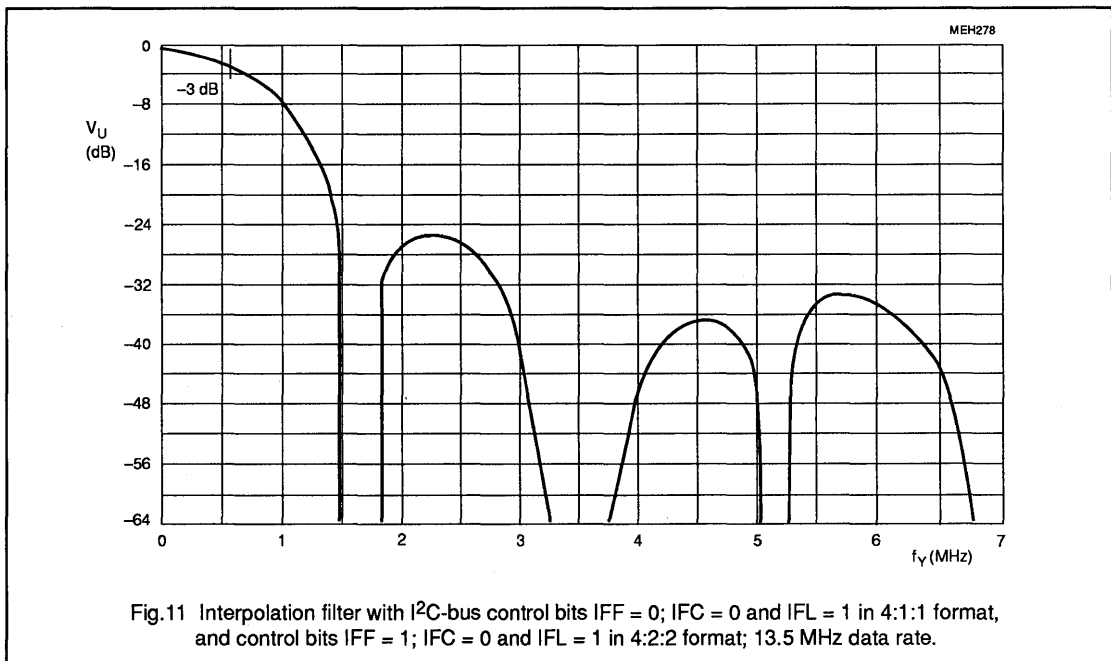
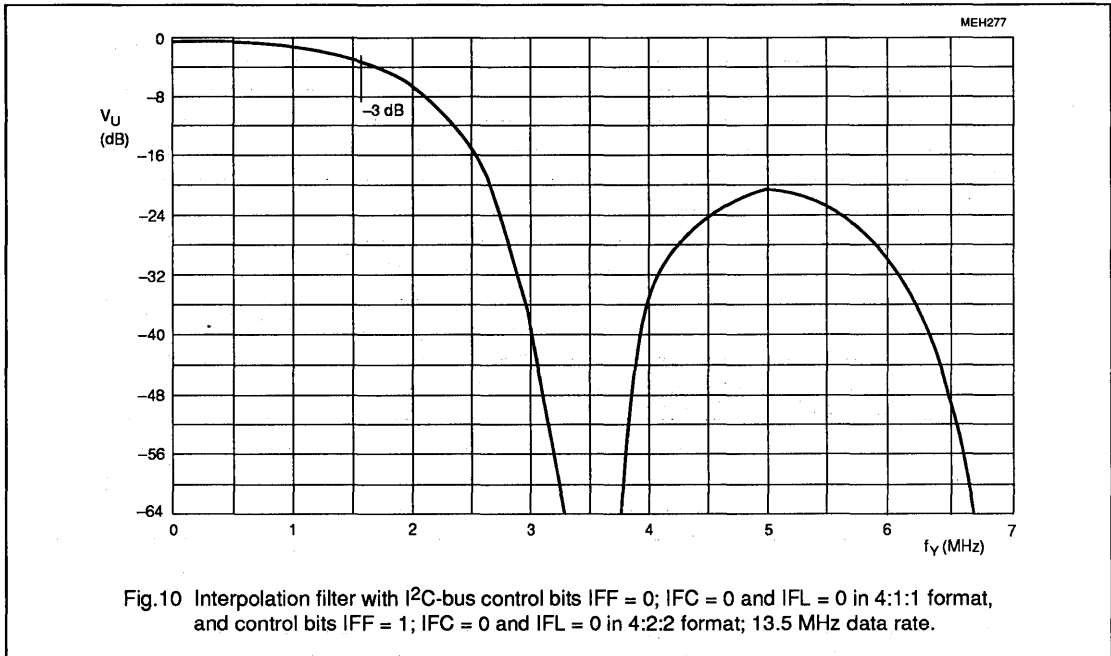

**Video enhancement  
and D/A processor (VEDA)**

**SAA9065**

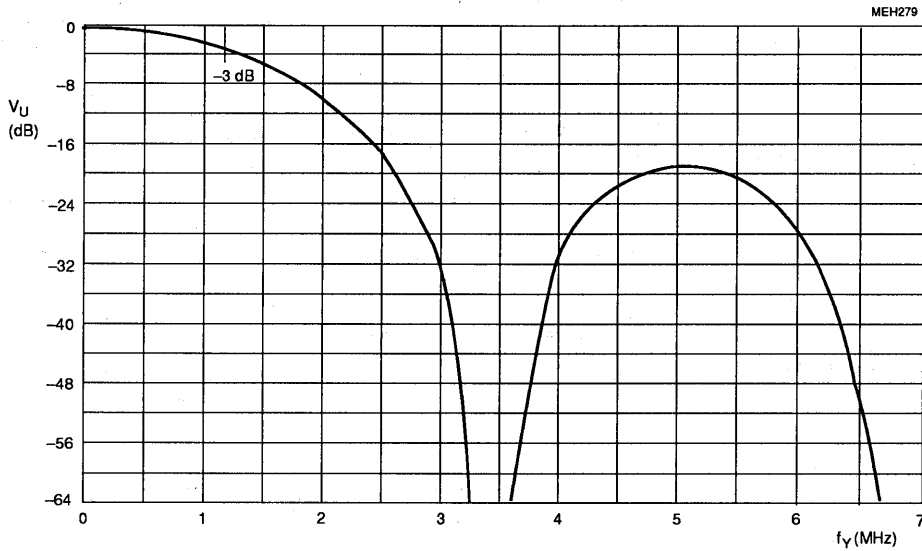

Fig.12 Interpolation filter with I<sup>2</sup>C-bus control bits IFF = 0; IFC = 1 and IFL = 0 in 4:1:1 format; 13.5 MHz data rate.

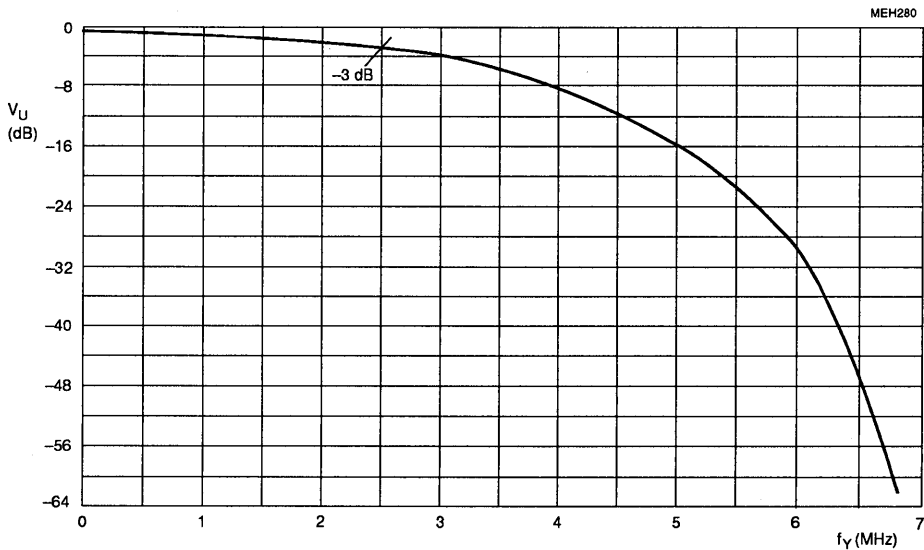

Fig.13 Interpolation filter with I<sup>2</sup>C-bus control bits IFF = 1; IFC = 1 and IFL = X in 4:2:2 format; 13.5 MHz data rate.

# Horizontal combination

# TDA2595

## GENERAL DESCRIPTION

The TDA2595 is a monolithic integrated circuit intended for use in colour television receivers.

## FEATURES

- Positive video input; capacitively coupled (source impedance < 200Ω)
- Adaptive sync separator; slicing level at 50% of sync amplitude
- Internal vertical pulse separator with double slope integrator
- Output stage for vertical sync pulse or composite sync depending on the load; both are switched off at muting
- $\phi_1$  phase control between horizontal sync and oscillator
- Coincidence detector  $\phi_3$  for automatic time-constant switching; overruled by the VCR switch
- Time-constant switch between two external time-constants or loop-gain; both controlled by the coincidence detector  $\phi_3$
- $\phi_1$  gating pulse controlled by coincidence detector  $\phi_3$
- Mute circuit depending on TV transmitter identification
- $\phi_2$  phase control between line flyback and oscillator; the slicing levels for  $\phi_2$  control and horizontal blanking can be set separately
- Burst keying and horizontal blanking pulse generation, in combination with clamping of the vertical blanking pulse (three-level sandcastle)
- Horizontal drive output with constant duty cycle inhibited by the protection circuit or the supply voltage sensor
- Detector for too low supply voltage
- Protection circuit for switching off the horizontal drive output continuously if the input voltage is below 4V or higher than 8V
- Line flyback control causing the horizontal blanking level at the sandcastle output continuously in case of a missing flyback pulse
- Spot-suppressor controlled by the line flyback control

## QUICK REFERENCE DATA

SYMBOL	PARAMETER	MIN.	TYP.	MAX.	UNIT
$V_{15-S} = V_P$	Supply voltage (Pin 15)		12		12V
$V_{I(p-p)}$	Sync pulse amplitude (positive video)	50			50mV
$I_4$	Horizontal output current	50			50mA

## PACKAGE OUTLINE

18-lead DIL; plastic (SOT102).



# Horizontal combination

# TDA2595

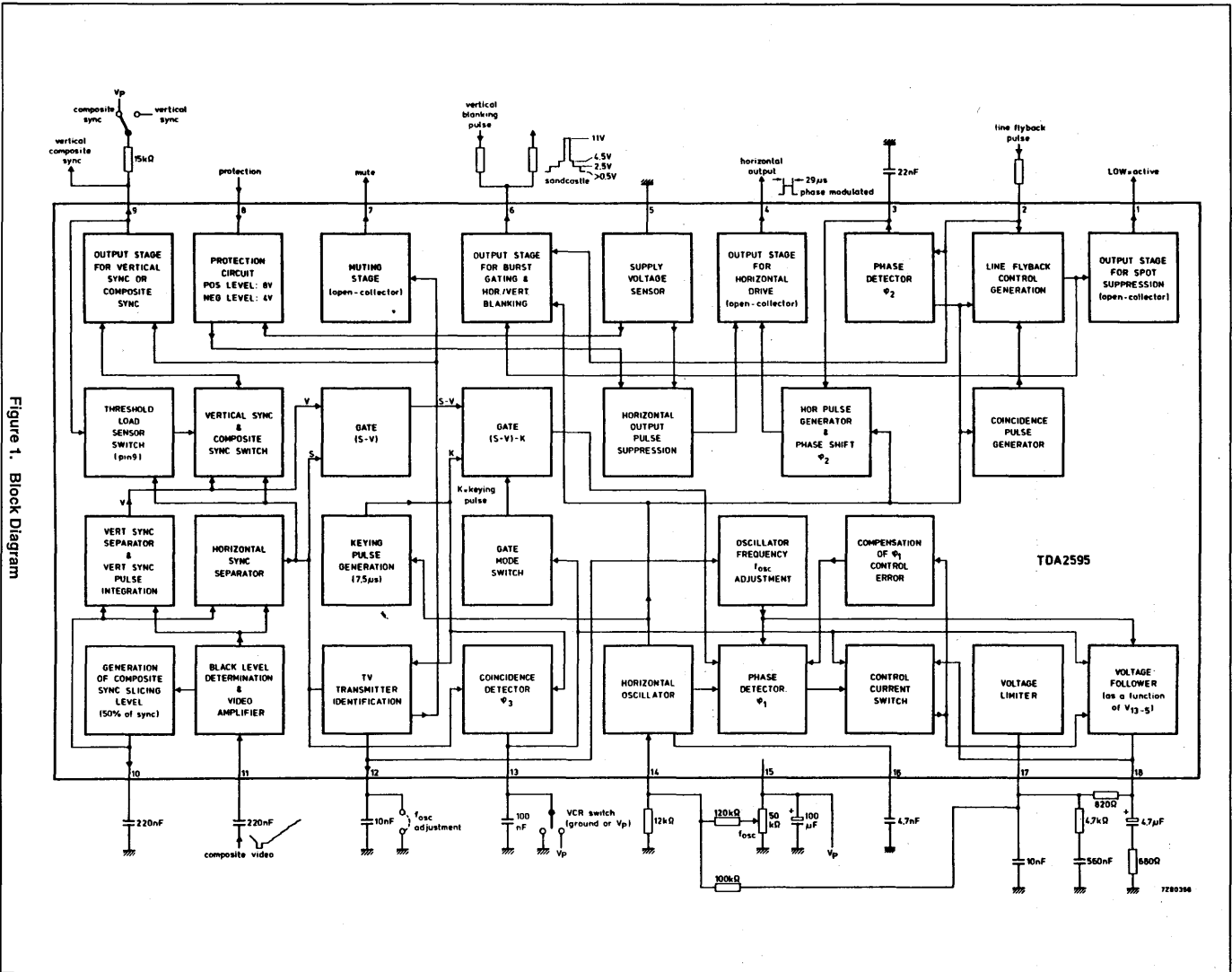

Figure 1. Block Diagram

## Horizontal combination

TDA2595

**RATINGS**

Limiting values in accordance with the Absolute Maximum System (IEC 134)

Supply voltage (Pin 15)	$V_{15-5} = V_P$	MAX.	13.2 V
Voltages at:			
Pins 1, 4 and 7	$V_{1,4,7-5}$	MAX.	18 V
Pins 8, 13 and 18	$V_{8,13,18-5}$	MAX.	$V_P$ V
Pin 11 (range)	$V_{11-5}$	-0.5 to +6	V
Currents at:			
Pin 1	$I_1$	MAX.	10 mA
Pin 2 (peak value)	$\pm I_{2M}$	MAX.	10 mA
Pin 4	$I_4$	MAX.	100 mA
Pin 6 (peak value)	$\pm I_{6M}$	MAX.	6 mA
Pin 7	$I_7$	MAX.	10 mA
Pin 8 (range)	$I_8$	-5 to +1	mA
Pin 9 (range)	$I_9$	-10 to +3	mA
Pin 18	$\pm I_{18}$	MAX.	10 mA
Total power dissipation	$P_{tot}$	MAX.	800 mW
Storage temperature range	$T_{stg}$	-25 to +125	°C
Operating ambient temperature range	$T_{amb}$	0 to +70	°C

## PAL/NTSC decoder

## TDA3566A

**FUNCTIONAL DESCRIPTION**

The TDA3566A is a further development of the TDA3562A. It has the same pinning and nearly the same application. The differences between the TDA3562A and the TDA3566A are as follows:

- The NTSC-application has largely been simplified. In the event of NTSC the chrominance signal is now internally coupled to the demodulators, automatic chrominance control (ACC) and phase detectors. The chrominance output signal (pin 28) is thus suppressed. It follows that the external switches and filters which are required for the TDA3562A are not required for the TDA3566A. There is no difference between the amplitudes of the colour output signals in the PAL or NTSC mode.
- The clamp capacitor at pins 10, 20 and 21 in the black-level stabilization loop can be reduced to 100 nF provided the stability of the loop is maintained. Loop stability depends on complete application. The clamp capacitors receive a pre-bias voltage to avoid coloured background during switch-on.
- The crystal oscillator circuit has been changed to prevent parasitic oscillations on the third overtone of the crystal. Consequently the optimum tuning capacitance must be reduced to 10 pF.
- The hue control has been improved (linear).

**Luminance amplifier**

The luminance amplifier is voltage driven and requires an input signal of 450 mV peak-to-peak (positive video). The luminance delay line must be connected between the IF amplifier and the decoder.

The input signal is AC coupled to the input (pin 8). After amplification, the black level at the output of the

preamplifier is clamped to a fixed DC level by the black level clamping circuit. During three line periods after vertical blanking, the luminance signal is blanked out and the black level reference voltage is inserted by a switching circuit.

This black level reference voltage is controlled via pin 11 (brightness). At the same time the RGB signals are clamped. Noise and residual signals have no influence during clamping thus simple internal clamping circuitry is used.

**Chrominance amplifiers**

The chrominance amplifier has an asymmetrical input. The input signal must be AC coupled (pin 4) and have a minimum amplitude of 40 mV peak-to-peak.

The gain control stage has a control range in excess of 30 dB, the maximum input signal must not exceed 1.1 V peak-to-peak, otherwise clipping of the input signal will occur.

From the gain control stage the chrominance signal is fed to the saturation control stage. Saturation is linearly controlled via pin 5. The control voltage range is 2 to 4 V, the input impedance is high and the saturation control range is in excess of 50 dB.

The burst signal is not affected by saturation control. The signal is then fed to a gated amplifier which has a 12 dB higher gain during the chrominance signal. As a result the signal at the output (pin 28) has a burst-to-chrominance ratio which is 6 dB lower than that of the input signal when the saturation control is set at -6 dB.

The chrominance output signal is fed to the delay line and, after matrixing, is applied to the demodulator input pins (pins 22 and 23). These signals

are fed to the burst phase detector. In the event of NTSC the chrominance signal is internally coupled to the demodulators, ACC and phase detectors.

**Oscillator and identification circuit**

The burst phase detector is gated with the narrow part of the sandcastle pulse (pin 7). In the detector the (R-Y) and (B-Y) signals are added to provide the composite burst signal again.

This composite signal is compared with the oscillator signal divided-by-2 (R-Y) reference signal. The control voltage is available at pins 24 and 25, and is also applied to the 8.8 MHz oscillator. The 4.4 MHz signal is obtained via the divide-by-2 circuit, which generates both the (B-Y) and (R-Y) reference signals and provides a 90° phase shift between them.

The flip-flop is driven by pulses obtained from the sandcastle detector. For the identification of the phase at PAL mode, the (R-Y) reference signal coming from the PAL switch, is compared to the vertical signal (R-Y) of the PAL delay line. This is carried out in the H/2 detector, which is gated during burst.

When the phase is incorrect, the flip-flop gets a reset from the identification circuit. When the phase is correct, the output voltage of the H/2 detector is directly related to the burst amplitude so that this voltage can be used for the ACC.

To avoid 'blooming-up' of the picture under weak input signal conditions the ACC voltage is generated by peak detection of the H/2 detector output signal. The killer and identification circuits receive their information from a gated output signal of H/2 detector. Killing is obtained via the saturation control stage and the demodulators to obtain good suppression.

## PAL/NTSC decoder

## TDA3566A

## PINNING

SYMBOL	PIN	DESCRIPTION
V <sub>P</sub>	1	supply voltage
IDDET	2	identification detection level
ACCDDET	3	Automatic Chrominance Control detection level
CHR <sub>IN</sub>	4	chrominance control input
SAT	5	saturation control input
CON	6	contrast control input
SC	7	sandcastle input
LUM	8	luminance control input
DBL	9	data blanking input
BCL <sub>R</sub>	10	black clamp level for RED output
BRI	11	brightness input
R <sub>IN</sub>	12	RED input
R <sub>OUT</sub>	13	RED output
G <sub>IN</sub>	14	GREEN input
G <sub>OUT</sub>	15	GREEN output
B <sub>IN</sub>	16	BLUE input
B <sub>OUT</sub>	17	BLUE output
BLA	18	black current input
BCL	19	black clamp level; referenced to black level
BCL <sub>B</sub>	20	black clamp level for BLUE output
BCL <sub>G</sub>	21	black clamp level for GREEN output
B-Y	22	demodulator input (BLUE)
R-Y	23	demodulator input (RED)
RCEXT	24	gated burst detector load network
RCEXT	25	gated burst detector load network
OSC	26	oscillator frequency input
GND	27	ground
CHR <sub>OUT</sub>	28	chrominance signal output

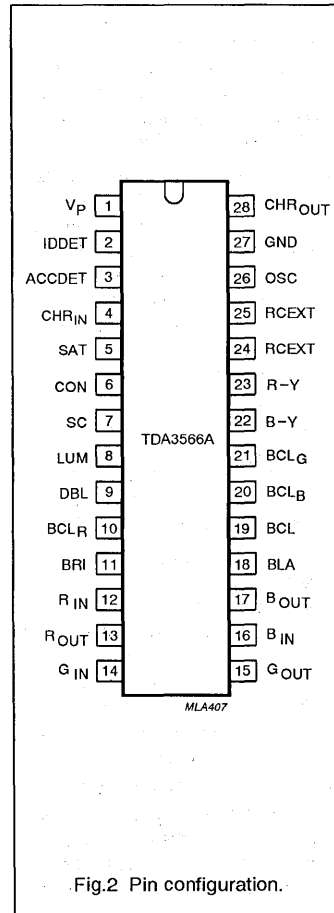

PAL/NTSC decoder

TDA3566A

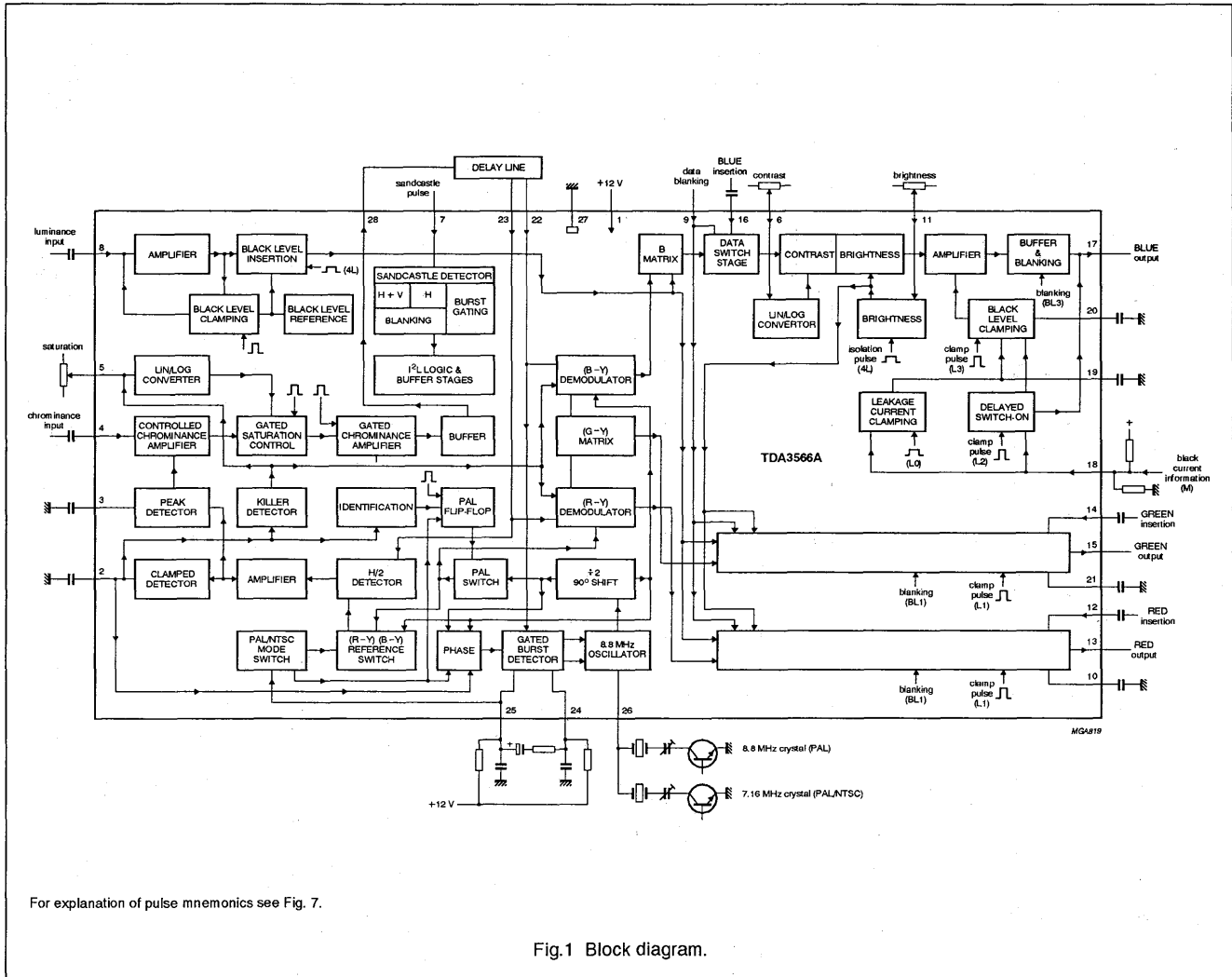

Fig.1 Block diagram.

For explanation of pulse mnemonics see Fig. 7.

## PAL/NTSC decoder

## TDA3566A

## FEATURES

- A black-current stabilizer which controls the black-currents of the three electron-guns to a level low enough to omit the black-level adjustment
- Contrast control of inserted RGB signals
- No black-level disturbance when non-synchronized external RGB signals are available on the inputs
- NTSC capability with hue control.

## APPLICATIONS

- Teletext/broadcast antiope
- Channel number display.

## GENERAL DESCRIPTION

The TDA3566A is a decoder for the PAL and/or NTSC colour television standards. It combines all functions required for the identification and demodulation of PAL/NTSC signals.

Furthermore it contains a luminance amplifier, an RGB-matrix and amplifier. These amplifiers supply output signals up to 4 V peak-to-peak (picture information) enabling direct drive of the discrete output stages. The circuit also contains separate inputs for data insertion, analog and digital, which can be used for text display systems.

## QUICK REFERENCE DATA

All voltages referenced to ground.

SYMBOL	PARAMETER	MIN.	TYP.	MAX.	UNIT
<b>Supply</b>					
$V_P$	supply voltage (pin 1)	–	12	–	V
$I_P$	supply current (pin 1)	–	90	–	mA
<b>Luminance amplifier (pin 8)</b>					
$V_{8(p-p)}$	input voltage (peak-to-peak value)	–	450	–	mV
CON	contrast control	–	16.5	–	dB
<b>Chrominance amplifier (pin 4)</b>					
$V_{4(p-p)}$	input voltage (peak-to-peak value)	40	–	1100	mV
SAT	saturation control	–	50	–	dB
<b>RGB matrix and amplifiers</b>					
$V_{13, 15, 17(p-p)}$	output voltage at nominal luminance and contrast (peak-to-peak value)	–	3.8	–	V
<b>Data insertion</b>					
$V_{12, 14, 16(p-p)}$	input signals (peak-to-peak value)	–	1	–	V
<b>Data blanking (pin 9)</b>					
$V_9$	input voltage for data insertion	0.9	–	–	V
<b>Sandcastle input (pin 7)</b>					
$V_7$	blanking input voltage	–	1.5	–	V
$V_7$	burst gating and clamping input voltage	–	7	–	V

## ORDERING INFORMATION

EXTENDED TYPE NUMBER	PACKAGE			
	PINS	PIN POSITION	MATERIAL	CODE
TDA3566A	28	DIL	plastic	SOT117

## Horizontal combination

TDA2595

**CHARACTERISTICS** (Continued) $V_P = 12V$ ;  $T_{amb} = +25^\circ C$ ; measured in Figure 1; unless otherwise specified

SYMBOL	PARAMETER	MIN.	TYP.	MAX.	UNIT
<b>Mute output (pin 7)</b>					
$V_{7-5}$	Output voltage at $I_7 = 3mA$ ; no TV transmitter	—	—	0.5	V
$R_{7-5}$	Output resistance at $I_7 = 3mA$ ; no TV transmitter	—	—	100	$\Omega$
$I_7$	Output leakage current at $V_{12-5} > 3V$ ; TV transmitter identified	—	—	5	$\mu A$
<b>Protection circuit (beam-current/EHT voltage protection) (pin 8)</b>					
$V_{8-5}$	No-load voltage for $I_8 = 0$ (operative condition)	—	6	—	V
$V_{8-5}$	Threshold at positive-going voltage	—	$8 \pm 0.8$	—	V
$V_{8-5}$	Threshold at negative-going voltage	—	$4 \pm 0.4$	—	V
$\pm I_8$	Current limiting for $V_{8-5} = 1$ to 8.5V	—	60	—	$\mu A$
$R_{8-5}$	Input resistance for $V_{8-5} > 8.5V$	—	3	—	$k\Omega$
$t_d$	Internal response delay of threshold switch	—	10	—	$\mu s$
<b>Control output of line flyback pulse control (pin 1)</b>					
$V_{1-5sat}$	Saturation voltage at standard operation; $I_1 = 3mA$	—	—	0.5	V
$I_1$	Output leakage current in case of disturbance of line flyback pulse	—	—	5	$\mu A$

**NOTES TO THE CHARACTERISTICS:**

1. Phase comparison between horizontal oscillator and the line flyback pulse. Generation of a phase modulated ( $\phi_2$ ) horizontal output pulse with constant duration.
2.  $t_{fp}$  is the line flyback pulse duration.
3. Three-level sandcastle pulse.
4. If pin 12 is connected to  $V_P$  the vertical output is active independent of synchronization state.

## Horizontal combination

TDA2595

**CHARACTERISTICS (Continued)** $V_P = 12V$ ;  $T_{amb} = +25^\circ C$ ; measured in Figure 1; unless otherwise specified

SYMBOL	PARAMETER	MIN.	TYP.	MAX.	UNIT
<b>Phase comparison <math>\phi_2</math> (pins 2 and 3) — SEE NOTE 1</b>					
<b>Input for line flyback pulse (pin 2)</b>					
$V_{2-5}$	Switching level for $\phi_2$ comparison and flyback control	—	3	—	V
$V_{2-5}$	Switching level for horizontal blanking	—	0.3	—	V
$V_{2-5}$	Input voltage limiting	—	-0.7	—	V
		—	+4.5	—	V
$I_2$	Switching current at horizontal flyback	0.01	1	—	mA
		—	—	2	$\mu A$
$I_2$	at horizontal scan	—	—	2	$\mu A$
$-I_2$	Maximum negative input current	—	—	500	$\mu A$
<b>Phase detector output (pin 3)</b>					
$\pm I_3$	Control current for $\phi_2$	—	1	—	mA
$\Delta t \phi_2$	Control range	—	19	—	$\mu s$
$\Delta t / \Delta t_d$	Static control error	—	—	0.2	%
$I_3$	Leakage current	—	—	5	$\mu A$
$\Delta t$	Phase relation between middle of the horizontal sync pulse and the middle of the line flyback pulse at $t_{fp} = 12\mu s$ (NOTE 2)	—	$2.6 \pm 0.7$	—	$\mu s$
$\Delta t / \Delta t$	If additional adjustment is required, it can be arranged by applying a current at pin 3	—	30	—	$\mu A / \mu s$
<b>Burst gating pulse (pin 6) (NOTE 3)</b>					
$V_{6-5}$	Output voltage	10	11	—	V
$t_p$	Pulse duration	3.7	4	4.3	$\mu s$
$t_{\phi_6}$	Phase relation between middle of sync pulse at the input and the leading edge of the burst gating pulse at $V_{6-5} = 7V$	2.15	2.65	3.15	$\mu s$
$I_6$	Output trailing edge current	—	2	—	mA
<b>Horizontal blanking pulse (pin 6) (NOTE 3)</b>					
$V_{6-5}$	Output voltage	4.1	4.5	4.9	V
$I_6$	Output trailing edge current	—	2	—	mA
$V_{6-5sat}$	Saturation voltage at horizontal scan	—	—	0.5	V
<b>Clamping circuit for vertical blanking pulse (pin 6) (NOTE 3)</b>					
$V_{6-5}$	Output voltage at $I_6 = 2.8mA$	2.15	2.5	3	V
$I_{6min}$	Minimum output current at $V_{6-5} > 2.15V$	—	2.3	—	mA
$I_{6max}$	Maximum output current at $V_{6-5} < 3V$	—	3.3	—	mA
<b>TV-transmitter identification (pin 12) (NOTE 4)</b>					
$V_{12-5}$	Output voltage	—	—	1	V
	no TV transmitter	—	—	1	V
$V_{12-5}$	TV transmitter identified	7	—	—	V



## Horizontal combination

## TDA2595

**CHARACTERISTICS** (Continued)V<sub>P</sub> = 12V; T<sub>amb</sub> = +25°C; measured in Figure 1; unless otherwise specified

SYMBOL	PARAMETER	MIN.	TYP.	MAX.	UNIT
<b>Horizontal output pulse (pin 4)</b>					
V <sub>4-5</sub>	Output voltage LOW at I <sub>4</sub> = 50mA	—	—	0.5	V
t <sub>p</sub>	Pulse duration (HIGH)	—	29 ± 15	—	μs
V <sub>P</sub>	Supply voltage for switching off the output pulse (pin 15)	—	4	—	V
ΔV <sub>P</sub>	Hysteresis for switching on the output pulse	—	250	—	mV
<b>Phase comparison φ<sub>1</sub> (pin 17)</b>					
V <sub>17-5</sub>	Control voltage range	3.55	—	8.3	V
I <sub>17</sub>	Leakage current at V <sub>17-5</sub> = 3.55 to 8.3V	—	—	1	μA
±I <sub>17</sub>	Control current for external time-constant switch	1.8	2	2.2	mA
±I <sub>17</sub>	Control current at V <sub>18-5</sub> = V <sub>15-5</sub> and V <sub>13-5</sub> < 2 or V <sub>13-5</sub> > 9.5V	—	8	—	mA
±I <sub>17</sub>	Control current at V <sub>18-5</sub> = V <sub>15-5</sub> and V <sub>13-5</sub> = 2 to 9.5V	1.8	2	2.2	mA
Sφ	Horizontal oscillator control control sensitivity	6	—	—	kHz/μs
±Δf <sub>OSC</sub>	catching and holding range	—	680	—	Hz
±Δf <sub>OSC</sub>	spread of catching and holding range	—	10	—	%
t <sub>p</sub>	Internal keying pulse at V <sub>13-5</sub> = 2.9 to 9.5V	—	7.5	—	μs
	Time-constant switch				
V <sub>13-5</sub>	slow time-constant at	9.5	—	2	V
V <sub>13-5</sub>	fast time-constant at	2	—	9.5	V
±V <sub>17-18</sub>	Impedance converter offset voltage (slow time-constant)	—	—	3	mV
R <sub>18-5</sub>	Output resistance slow time-constant	—	—	10	Ω
R <sub>18-5</sub>	fast time-constant	high impedance			
I <sub>18</sub>	Leakage current	—	—	1	μA
<b>Coincidence detector φ<sub>3</sub> (pin 13)</b>					
V <sub>13-5</sub>	Output voltage without coincidence with composite video signal	—	—	1	V
V <sub>13-5</sub>	without coincidence without composite video signal (noise)	—	—	2	V
V <sub>13-5</sub>	with coincidence with composite video signal	—	6	—	V
I <sub>13</sub>	Output current without coincidence with composite video signal	—	50	—	μA
-I <sub>13</sub>	with coincidence with composite video signal	—	300	—	μA
I <sub>13</sub>	Switching current at V <sub>13-5</sub> = V <sub>P</sub> - 0.5V	—	—	100	μA
I <sub>13(av)</sub>	at V <sub>13-5</sub> = 0.5V (average value)	—	—	100	μA

## Horizontal combination

TDA2595

## CHARACTERISTICS

 $V_P = 12V$ ;  $T_{amb} = +25^\circ C$ ; measured in Figure 1; unless otherwise specified

SYMBOL	PARAMETER	MIN.	TYP.	MAX.	UNIT
<b>Composite video input and sync separator (pin 11)</b>					
$V_{11-5(p-p)}$	Input signal (positive video; standard signal; peak-to-peak value)	0.2	1	3	V
$V_{11-5(p-p)}$	Sync pulse amplitude (independent of video content)	50	—	—	mV
$R_G$	Generator resistance	—	—	200	$\Omega$
$I_{11}$ $-I_{11}$ $-I_{11}$	Input current during:				
	video	—	5	—	$\mu A$
	sync pulse	—	40	—	$\mu A$
	black level	—	25	—	$\mu A$
<b>Composite sync generation (pin10) horizontal slicing level at 50% of the sync pulse amplitude for <math>V_{11-5(p-p)} &lt; 1.5V</math></b>					
$I_{10}$ $-I_{10}$	Capacitor current during:				
	video	—	16	—	$\mu A$
	sync pulse	—	170	—	$\mu A$
<b>Vertical sync pulse generation slicing level at 30% (60% between black level and horizontal slicing level); pin 9</b>					
$V_{9-5}$	Output voltage	10	—	—	V
$t_p$	Pulse duration	—	190	—	$\mu s$
$t_d$	Delay with respect to the vertical sync pulse (leading edge)	—	45	—	$\mu s$
	Pulse-mode control	no current applied at pin 9			
	output current for vertical sync pulse (dual integrated)	current applied via a resistor of 15k $\Omega$ from $V_p$ to pin 9			
	output current for horizontal and vertical sync pulse (non-integrated separated signal)				
<b>Horizontal oscillator (pins 14 and 16)</b>					
$f_{osc}$	Frequency; free running	—	15625	—	Hz
$V_{14-5}$	Reference voltage for $f_{osc}$	—	6	—	V
$\Delta f_{osc}/\Delta I_{14}$	Frequency control sensitivity	—	31	—	Hz/ $\mu A$
$\Delta f_{osc}$	Adjustment range of circuit Figure 1	—	$\pm 10$	—	%
$\Delta f_{osc}$	Spread of frequency	—	—	5	%
$\frac{\Delta f_{osc}/f_{osc}}{\Delta V_{15-5}/V_{15-5}}$	Frequency dependency (excluding tolerance of external components)				
	with supply voltage ( $V_P = 12V$ )	—	$\pm 0.05$	—	
$\Delta f_{osc}$	with supply voltage drop of 5V	—	—	10	%
TC	with temperature	—	—	$\pm 10^{-4}$	$K^{-1}$
$+I_{16}$ $-I_{16}$	Capacitor current during:				
	discharging	—	1024	—	$\mu A$
	charging	—	313	—	$\mu A$
$t_r$ $t_f$	Sawtooth voltage timing (pin 14)				
	rise time	—	49	—	$\mu s$
	fall time	—	15	—	$\mu s$

## PAL/NTSC decoder

## TDA3566A

The time constant of the saturation control (pin 5) provides a delayed switch-on after killing. Adjustment of the oscillator is achieved by variation of the burst phase detector load resistance between pins 24 and 25 (see Fig.8).

With this application the trimmer capacitor in series with the 8.8 MHz crystal (pin 26) can be replaced by a fixed value capacitor to compensate for unbalance of the phase detector.

### Demodulator

The (R-Y) and (B-Y) demodulators are driven by the colour difference signals from the delay-line matrix circuit and the reference signals from the 8.8 MHz divider circuit. The (R-Y) reference signal is fed via the PAL-switch. The output signals are fed to the R and B matrix circuits and to the (G-Y) matrix to provide the (G-Y) signal which is applied to the G-matrix. The demodulation circuits are killed and blanked by by-passing the input signals.

### NTSC mode

The NTSC mode is switched on when the voltage at the burst phase detector outputs (pins 24 and 25) is adjusted below 9 V.

To ensure reliable application the phase detector load resistors are external. When the TDA3566A is used only for PAL these two 33 k $\Omega$  resistors must be connected to +12 V (see Fig.8).

For PAL/NTSC application the value of each resistor must be reduced to 20 k $\Omega$  (with a tolerance of 1%) and connected to the slider of a potentiometer (see Fig.9). The switching transistor brings the voltage at pins 24 and 25 below 9 V which switches the circuit to the NTSC mode.

The position of the PAL flip-flop ensures that the correct phase of the (R-Y) reference signal is supplied to the (R-Y) demodulator.

The drive to the H/2 detector is now provided by the (B-Y) reference signal. In the PAL mode it is driven by the (R-Y) reference signal. Hue control is realized by changing the phase of the reference drive to the burst phase detector.

This is achieved by varying the voltage at pins 24 and 25 between 7.0 V and 8.5 V, nominal position 7.65 V. The hue control characteristic is shown in Fig.6.

### RGB matrix and amplifiers

The three matrix and amplifier circuits are identical and only one circuit will be described.

The luminance and the colour difference signals are added in the matrix circuit to obtain the colour signal, which is then fed to the contrast control stage.

The contrast control voltage is supplied to pin 6 (high-input impedance). The control range is +5 dB to -11.5 dB nominal. The relationship between the control voltage and the gain is linear (see Fig.3).

During the 3-line period after blanking a pulse is inserted at the output of the contrast control stage. The amplitude of this pulse is varied by a control voltage at pin 11. This applies a variable offset to the normal black level, thus providing brightness control.

The brightness control range is 1 V to 3.6 V. While this offset level is present, the black-current input impedance (pin 18) is high and the internal clamp circuit is activated. The clamp circuit then compares the

reference voltage at pin 19 with the voltage developed across the external resistor network  $R_A$  and  $R_B$  (pin 18) which is provided by picture tube beam current.

The output of the comparator is stored in capacitors connected from pins 10, 20 and 21 to ground which controls the black level at the output.

The reference voltage is composed by the resistor divider network and the leakage current of the picture tube into this bleeder. During vertical blanking, this voltage is stored in the capacitor connected to pin 19, which ensures that the leakage current of the CRT does not influence the black current measurement.

The RGB output signals can never exceed a level of 10.6 V. When the signal tends to exceed this level the output signal is clipped. The black level at the outputs (pins 13, 15 and 17) will be approximately 3 V. This level depends on the spread of the guns of the picture tube. If a beam current stabilizer is not used it is possible to stabilize the black levels at the outputs, which in this application must be connected to the black current measuring input (pin 18) via a resistor network.

## PAL/NTSC decoder

## TDA3566A

**Data insertion**

Each colour amplifier has a separate input for data insertion.

A 1 V peak-to-peak input signal provides a 3.8 V peak-to-peak output signal.

To avoid the black-level of the inserted signal differing from the black level of the normal video signal, the data is clamped to the black level of the luminance signal. Therefore AC coupling is required for the data inputs.

To avoid a disturbance of the blanking level due to the clamping circuit, the source impedance of the driver circuit must not exceed 150  $\Omega$ . The data insertion circuit is activated by the data blanking input (pin 9). When the

voltage at this pin exceeds a level of 0.9 V, the RGB matrix circuits are switched off and the data amplifiers are switched on.

To avoid coloured edges, the data blanking switching time is short. The amplitude of the data output signals is controlled by the contrast control at pin 6. The black level is equal to the video black level and can be varied between 2 and 4 V (nominal condition) by the brightness control voltage at pin 11.

Non-synchronized data signals do not disturb the black level of the internal signals.

**Blanking of RGB and data signals**

Both the RGB and data signals can be blanked via the sandcastle input (pin 7). A slicing level of 1.5 V is used for this blanking function, so that the wide part of the sandcastle pulse is separated from the remainder of the pulse. During blanking a level of +1 V is available at the output. To prevent parasitic oscillations on the third overtone of the crystal the optimum tuning capacitance should be 10 pF.

**LIMITING VALUES**

In accordance with the Absolute Maximum Rating System (IEC 134).

SYMBOL	PARAMETER	MIN.	MAX.	UNIT
$V_P$	supply voltage (pin 1)	-	13.2	V
$P_{tot}$	total power dissipation	-	1700	mW
$T_{amb}$	operating ambient temperature	-25	+70	$^{\circ}\text{C}$
$T_{stg}$	storage temperature	-25	+150	$^{\circ}\text{C}$

**THERMAL RESISTANCE**

SYMBOL	PARAMETER	THERMAL RESISTANCE
$R_{th\ j-a}$	from junction to ambient in free air	40 K/W

## PAL/NTSC decoder

TDA3566A

## CHARACTERISTICS

$V_P = 12\text{ V}$ ;  $T_{\text{amb}} = 25\text{ }^\circ\text{C}$ ; all voltages are referenced to pin 27; unless otherwise specified.

SYMBOL	PARAMETER	CONDITIONS	MIN.	TYP.	MAX.	UNIT
<b>Supply</b>						
$V_P$	supply voltage		10.8	12.0	13.2	V
$I_P$	supply current		–	90	120	mA
$P_{\text{tot}}$	total power dissipation		–	1.1	1.6	W
<b>Luminance input (pin 8)</b>						
$V_{B(p-p)}$	input voltage (peak-to-peak value)	note 1	–	0.45	0.63	V
$V_B$	input voltage level before clipping occurs in the input stage		–	–	1.4	V
$I_B$	input current		–	0.1	1	$\mu\text{A}$
	contrast control range	see Fig.3	–11.5	–	+5	dB
$I_6$	input current contrast control		–	–	15	$\mu\text{A}$
<b>Chrominance amplifier</b>						
$V_{4(p-p)}$	input signal amplitude (peak-to-peak value)	note 2	40	390	1 100	mV
$ Z_4 $	input impedance		–	10	–	k $\Omega$
$C_4$	input capacitance		–	–	6.5	pF
	ACC control range		30	–	–	dB
$\Delta V$	change of the burst signal at the output control range	100 mV to 1 V (p-p)	–	–	1	dB
G	amplification at nominal saturation (pin 4 to pin 28)	note 3	34	–	–	dB
	chrominance to burst ratio at nominal saturation		–	7	–	dB
$V_{28(p-p)}$	maximum output voltage range (peak-to-peak value)	$R_L = 2\text{ k}\Omega$	4	5	–	V
d	distortion of chrominance amplifier at 2 V (p-p) output signal up to an input signal of 1 V (p-p)		–	–	5	%
$\alpha_{28-4}$	frequency response between 0 and 5 MHz		–	–	–2	dB
	saturation control range	see Fig.4	50	–	–	dB
$I_5$	input current saturation control		–	–	20	$\mu\text{A}$
	cross-coupling between luminance and chrominance amplifier	note 4	–	–	–46	dB
S/N	signal-to-noise ratio at nominal input signal	note 5	56	–	–	dB
$\Delta\varphi$	phase shift burst with respect to chrominance at nominal saturation		–	–	$\pm 5$	deg
$ Z_{28} $	output impedance of chrominance amplifier		–	10	–	$\Omega$

## PAL/NTSC decoder

## TDA3566A

SYMBOL	PARAMETER	CONDITIONS	MIN.	TYP.	MAX.	UNIT
$I_{28}$	output current		-	-	15	mA
<b>Reference part</b>						
$\Delta f$	phase-locked loop catching range	note 6	500	-	-	Hz
$\Delta\varphi$	phase shift for 400 Hz deviation of the oscillator frequency	note 6	-	-	5	deg
$TC_{osc}$	oscillator temperature coefficient with respect to oscillator frequency	note 6	-	-2	-3	Hz/K
$\Delta f_{osc}$	frequency deviation when supply voltage increases from 10 to 13.2 V	note 6	-	40	100	Hz
$R_{26}$	input resistance		280	400	520	$\Omega$
$C_{26}$	input capacitance		-	-	10	pF
<b>ACC generation (pin 2; note 7)</b>						
$V_2$	control voltage at nominal input signal		-	4.5	-	V
$V_2$	control voltage without chrominance input		-	2	-	V
$\Delta V_2$	colour-on/off voltage		175	300	425	mV
$V_2$	colour-on voltage		3.1	3.5	3.9	V
$\Delta V_2$	colour-on identification voltage		1.2	1.5	1.8	V
	change in burst amplitude with temperature		-	0.1	0.25	%/K
$V_3$	voltage at pin 3 at nominal input signal		-	4.7	-	V
<b>Demodulator part</b>						
$V_{23(p-p)}$	amplitude of burst signal (peak-to-peak value) between pins 23 and 27	note 8	45	63	81	mV
$ Z_{22, 23} $	input impedance between pins 22 or 23 and 27		0.7	1.0	1.3	k $\Omega$
RATIO OF DEMODULATED SIGNALS FOR EQUIVALENT INPUT SIGNALS AT PINS 22 AND 23						
$\frac{V_{17}}{V_{13}}$	(B-Y)/(R-Y)		-	$1.78 \pm 10\%$	-	
$\frac{V_{15}}{V_{13}}$	(G-Y)/(R-Y)	no (B-Y) signal	-	$-0.51 \pm 10\%$	-	
$\frac{V_{15}}{V_{17}}$	(G-Y)/(B-Y)	no (R-Y) signal	-	$-0.19 \pm 25\%$	-	
$\alpha_{17}$	frequency response between 0 and 1 MHz		-	-	-3	dB
$\alpha_{cr}$	cross-talk between colour difference signals		40	-	-	dB
$\Delta\varphi$	phase difference between (R-Y) and (B-Y) reference signals		85	90	95	deg

## PAL/NTSC decoder

## TDA3566A

SYMBOL	PARAMETER	CONDITIONS	MIN.	TYP.	MAX.	UNIT
$\Delta\varphi_{\text{tot}}$	total phase difference between chrominance input signals and demodulator output signals		–	–	8	deg
<b>RGB matrix and amplifiers</b>						
$V_{13, 15, 17(p-p)}$	output voltage (peak-to-peak value) at nominal luminance/contrast (black-to-white)	note 3	3.3	3.8	4.3	V
$V_{13(p-p)}$	output signal amplitude of the 'RED' channel (peak-to-peak value) at nominal contrast/saturation and no luminance signal to the input (R–Y signal)		–	3.7	–	V
$V_{13, 15, 17(m)}$	maximum peak-white level		9.4	10.0	10.6	V
$I_{13, 15, 17}$	available output current		10	–	–	mA
$\Delta V_{13, 15, 17}$	difference between black level and measuring level at the output for a brightness control voltage of 2 V	note 9	–	0	–	V
$\Delta V$	difference in black level between the three channels for equal drive conditions for the three gains	note 10	–	–	100	mV
	control range of black-current stabilization at $V_{\text{black}} = 3 \text{ V}$ ; $V_{11} = 2 \text{ V}$		–	–	$\pm 2$	V
$\Delta V$	black level shift with picture content		–	–	40	mV
	brightness control voltage range	see Fig.5	–	–	–	V
$I_{11}$	brightness control input current		–	–	5	$\mu\text{A}$
	slope of brightness control curve		–	1.3	–	V/V
	tracking of contrast control between the three channels over a control range at 10 dB		–	–	0.5	dB
$V_o$	output voltage during test pulse after switch-on		6.5	7.3	–	V
$\frac{\Delta V}{\Delta T}$	variation of black level with temperature		–	0	–	mV/K
$\Delta V$	variation of black level with contrast (+5 to –10 dB)	note 11	–	–	100	mV
	relative spread between the three output signals		–	–	10	%
$\Delta V$	relative black level variation between the three channels during variation of contrast, brightness and supply voltage	note 11	–	$0 \pm 10\%$	$20 \pm 10\%$	mV
$V_{\text{blk}}$	blanking level at the RGB outputs		–	0.85	1.1	V
$\Delta V_{\text{blk}}$	difference in blanking level of the three channels		–	0	10	mV
$dV_{\text{blk}}$	differential drift of the blanking levels	$\Delta T = 40 \text{ }^\circ\text{C}$	–	0	10	mV

## PAL/NTSC decoder

## TDA3566A

SYMBOL	PARAMETER	CONDITIONS	MIN.	TYP.	MAX.	UNIT
$\frac{\Delta V_{bl}}{V_{bl}} \times \frac{V_{Pl}}{\Delta V_{Pl}}$	tracking of output black level with supply voltage		0.9	1.0	1.1	
S/N	signal-to-noise ratio of output signals	note 5	62	–	–	dB
$V_{R(p-p)}$	residual 4.4 MHz signal at RGB outputs (peak-to-peak value)		–	–	100	mV
$V_{R(p-p)}$	residual 8.8 MHz signal and higher harmonics at the RGB outputs (peak-to-peak value)		–	–	150	mV
$ Z_o $	output impedance (pins 13, 15 and 17)		–	100	–	$\Omega$
$\alpha_{tot}$	frequency response of total luminance and RGB amplifier circuits for $f = 0$ MHz and 5 MHz		–	–1	–3	dB
$I_o$	current source of output stage		2	3	–	mA
$\Delta V$	difference of black level at the three outputs at nominal brightness	note 11	–	–	10	mV
	tracking of brightness control		–	–	2	%
<b>Data insertion</b>						
$V_{12, 14, 16(p-p)}$	input signals (peak-to-peak value) for an RGB output voltage of 3.8 V (peak-to-peak) at nominal contrast	note 4	0.9	1.0	1.1	V
$\Delta V$	difference between the black level of the RGB signals and the black level of the inserted signals at the outputs at nominal contrast	note 12	–	–	170	mV
$t_r$	output rise time		–	50	80	ns
$t_d$	difference delay for the three channels		–	0	40	ns
$I_{12, 14, 16}$	input current		–	–	10	$\mu A$
<b>Data blanking</b>						
$V_g$	input voltage for no data insertion		–	–	0.3	V
$V_g$	input voltage for data insertion		0.9	–	–	V
$V_g$	maximum input pulse voltage		–	–	3	V
$t_d$	delay of data blanking		–	–	20	ns
$R_g$	input resistance		7	10	13	k $\Omega$
	suppression of the internal RGB signals when $V_g > 0.9$ V		46	–	–	dB
	suppression of external RGB signals when $V_g < 0.3$ V		46	–	–	dB
<b>Sandcastle input (note 13)</b>						
$V_7$	level at which the RGB blanking is activated		1.0	1.5	2.0	V
$V_7$	level at which the horizontal pulses are separated		3.0	3.5	4.0	V



## PAL/NTSC decoder

## TDA3566A

SYMBOL	PARAMETER	CONDITIONS	MIN.	TYP.	MAX.	UNIT
$V_7$	level at which the burst gate and clamping pulse are separated		6.5	7.0	7.5	V
$t_d$	delay between black level clamping and burst gating pulse		-	0.6	-	$\mu$ s
$I_i$	input current	$V_i = 0$ to 1 V	-	-	-1	mA
		$V_i = 1$ to 8 V	-	-	50	$\mu$ A
		$V_i = 8$ to 12 V	-	-	2	mA
<b>Black current stabilization</b>						
$V_{18}$	DC bias voltage		3.5	5.0	7.0	V
$\Delta V$	difference between input voltage for black current and leakage current		0.35	0.5	0.65	V
$I_{18}$	input current during black current		-	-	1	$\mu$ A
$I_{18}$	input current during scan		-	-	10	mA
$V_{18}$	internal limiting at pin 18		8.5	9.0	9.5	V
$V_{18}$	switching threshold for black current control on		7.6	8.0	8.4	V
$R_{18}$	input resistance during scan		1.0	1.5	2.0	k $\Omega$
$I_{10, 20, 21}$	DC input current during scan at pins 10, 20 and 21		-	-	30	nA
	maximum charge or discharge current during measuring time (pins 10, 20 and 21)		-	1	-	mA
	difference in drift of the blank level	note 11; $\Delta T = 40$ °C		0	20	mV
<b>NTSC</b>						
$V_{24-25}$	level at which the PAL/NTSC switch is activated (pins 24 and 25)		-	8.8	9.2	V
$I_{24+25 (AV)}$	average output current (pin 24 plus pin 25)	note 14	62	82.5	103	$\mu$ A
HUE	hue control	see Fig.6	-	-	-	

**Notes to the characteristics**

- Signal with the negative-going sync; amplitude includes sync pulse amplitude.
- Indicated is a signal with 75% colour bar, so the chrominance-to-burst ratio is 2.2 : 1.
- Nominal contrast is specified as the maximum contrast -5 dB and nominal saturation as maximum -6 dB. This figure is valid in the PAL-condition. In the NTSC-condition no output signal is available at pin 28.
- Cross coupling is measured under the following condition: input signal nominal, contrast and saturation such that nominal output signals are obtained. The signals at the output at which no signal should be available must be compared with the nominal output signal at that output.
- The signal-to-noise ratio is defined as peak-to-peak signal with respect to RMS noise.
- All frequency variations are referenced to the 4.4 MHz carrier frequency. All oscillator specifications have been measured with the Philips crystal 4322 143 ... or 4322 144 ... series.
- The change in burst with  $V_p$  is proportional.

## PAL/NTSC decoder

## TDA3566A

8. These signal amplitudes are determined by the ACC circuit of the reference part.
9. This value depends on the gain setting of the RGB output amplifiers and the drift of the picture tube guns. Higher black level values are possible (up to 5 V) however, in that condition the amplitude of the available output signal is reduced.
10. The variation of the black-level during brightness control in the three different channels is directly dependent on the gain of each channel. Discolouration during adjustments of contrast and brightness does not occur because amplitude and the black-level change with brightness control are directly related.
11. With respect to the measuring pulse.
12. This difference occurs when the source impedance of the data signals is 150  $\Omega$  and the black level clamp pulse width is 4  $\mu\text{s}$  (sandcastle pulse). For a lower impedance the difference will be lower.
13. For correct operating of the black level stabilization loop, the leading and trailing edges of the sandcastle pulse (measured between 1.5 V and 3.5 V) must be within 200 ns and 600 ns respectively.
14. The voltage at pins 24 and 25 can be changed by connecting the load resistors (20 k $\Omega$ , 1%, in this condition) to the slider bar of the hue control potentiometer (see Fig.6). When the transistor is switched on, the voltage at pins 24 and 25 is reduced below 9 V, and the circuit is switched to NTSC mode. The width of the burst gate is assumed to be 4  $\mu\text{s}$  typical.

PAL/NTSC decoder

TDA3566A

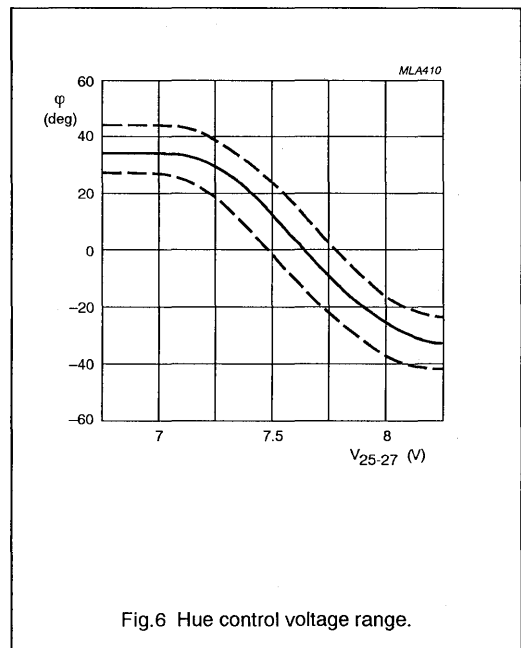
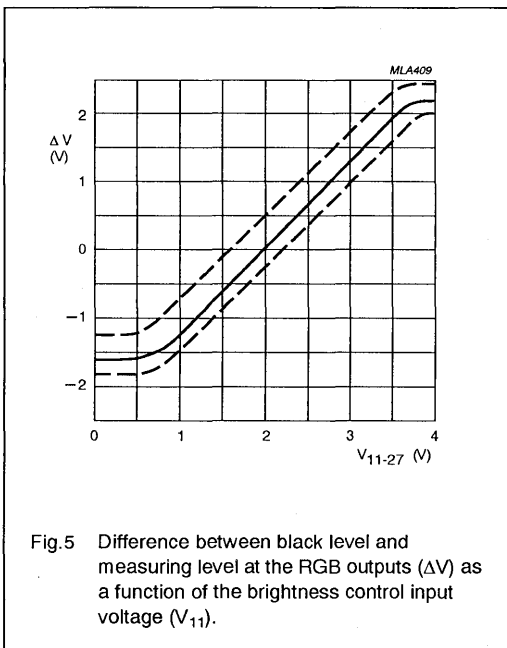
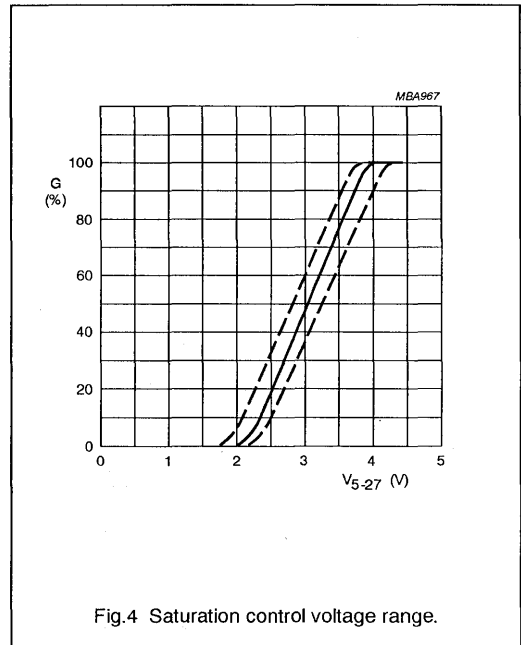
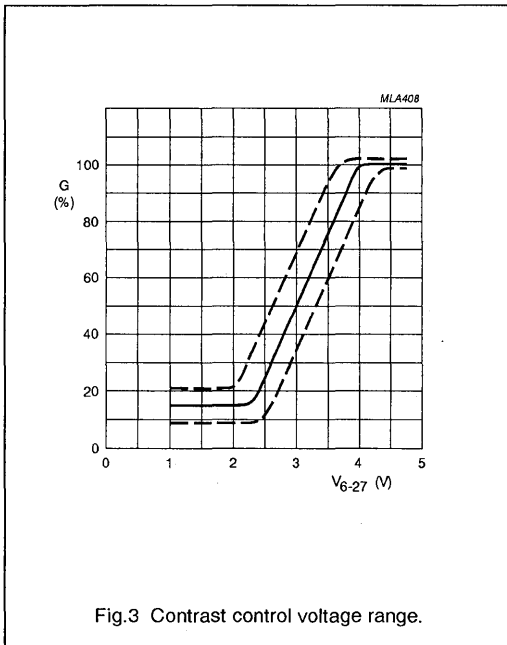

PAL/NTSC decoder

TDA3566A

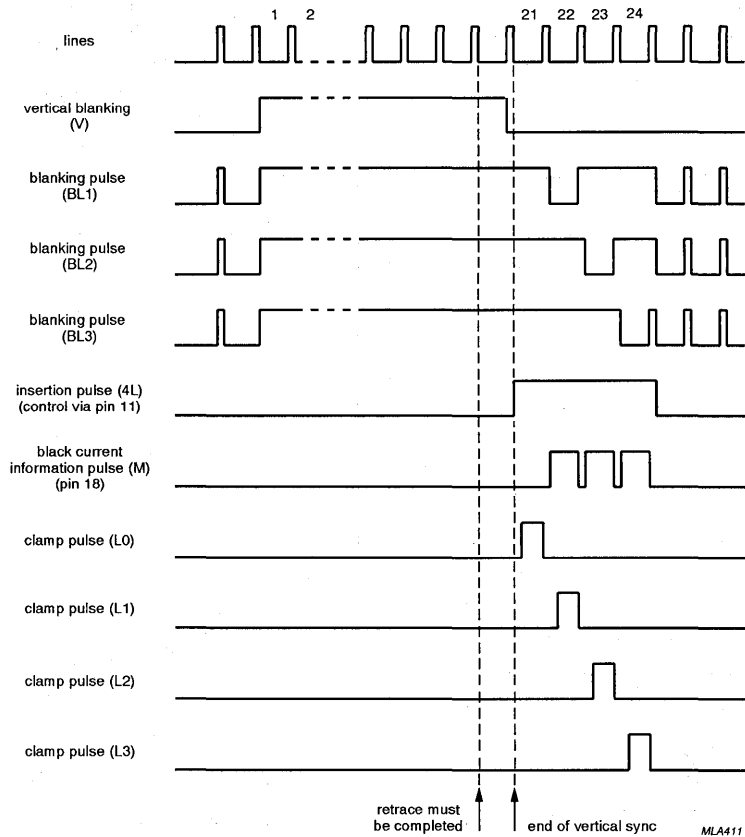

Fig.7 Timing diagram for black-current stabilization.

PAL/NTSC decoder

TDA3566A

APPLICATION INFORMATION

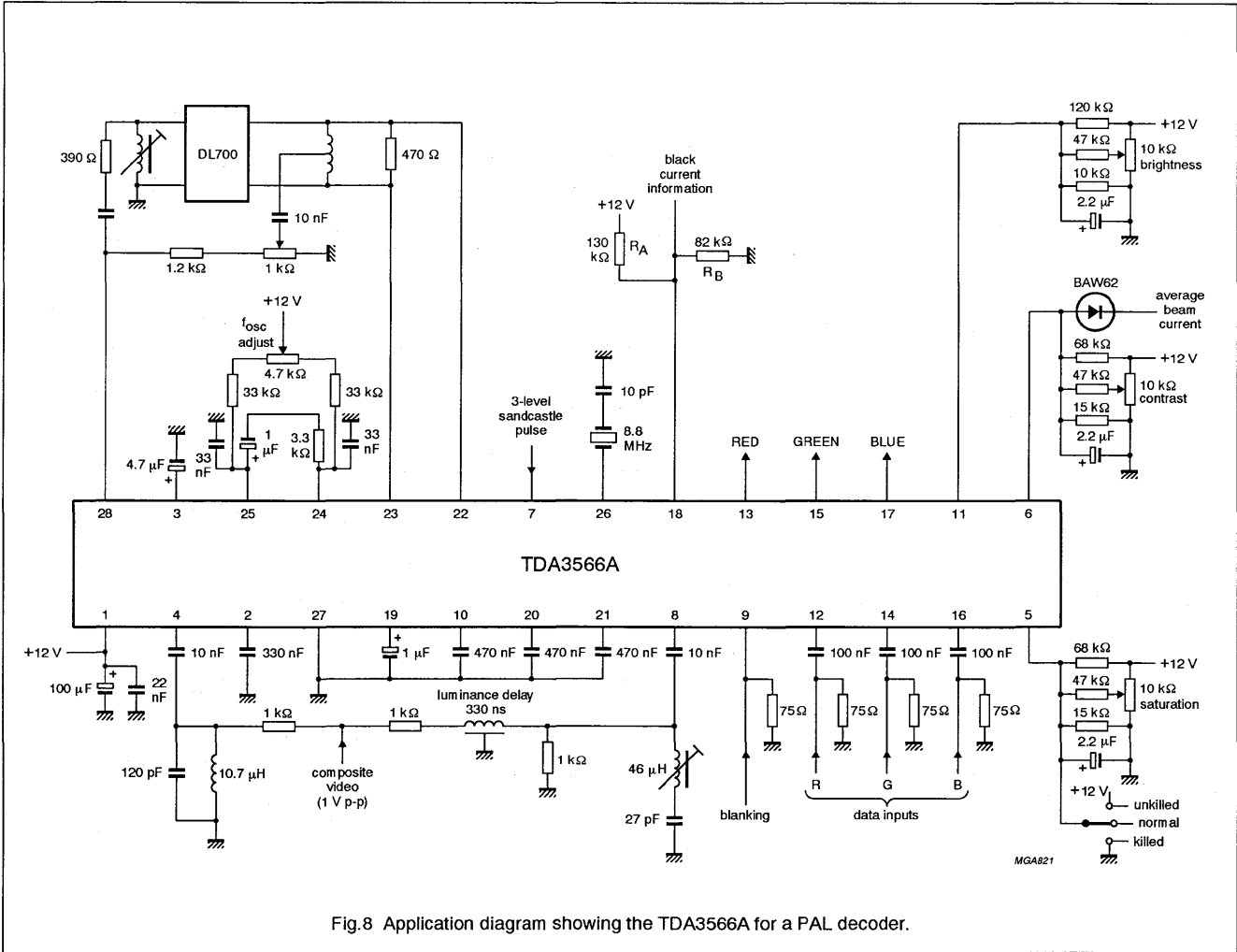

Fig.8 Application diagram showing the TDA3566A for a PAL decoder.

PAL/NTSC decoder

TDA3566A

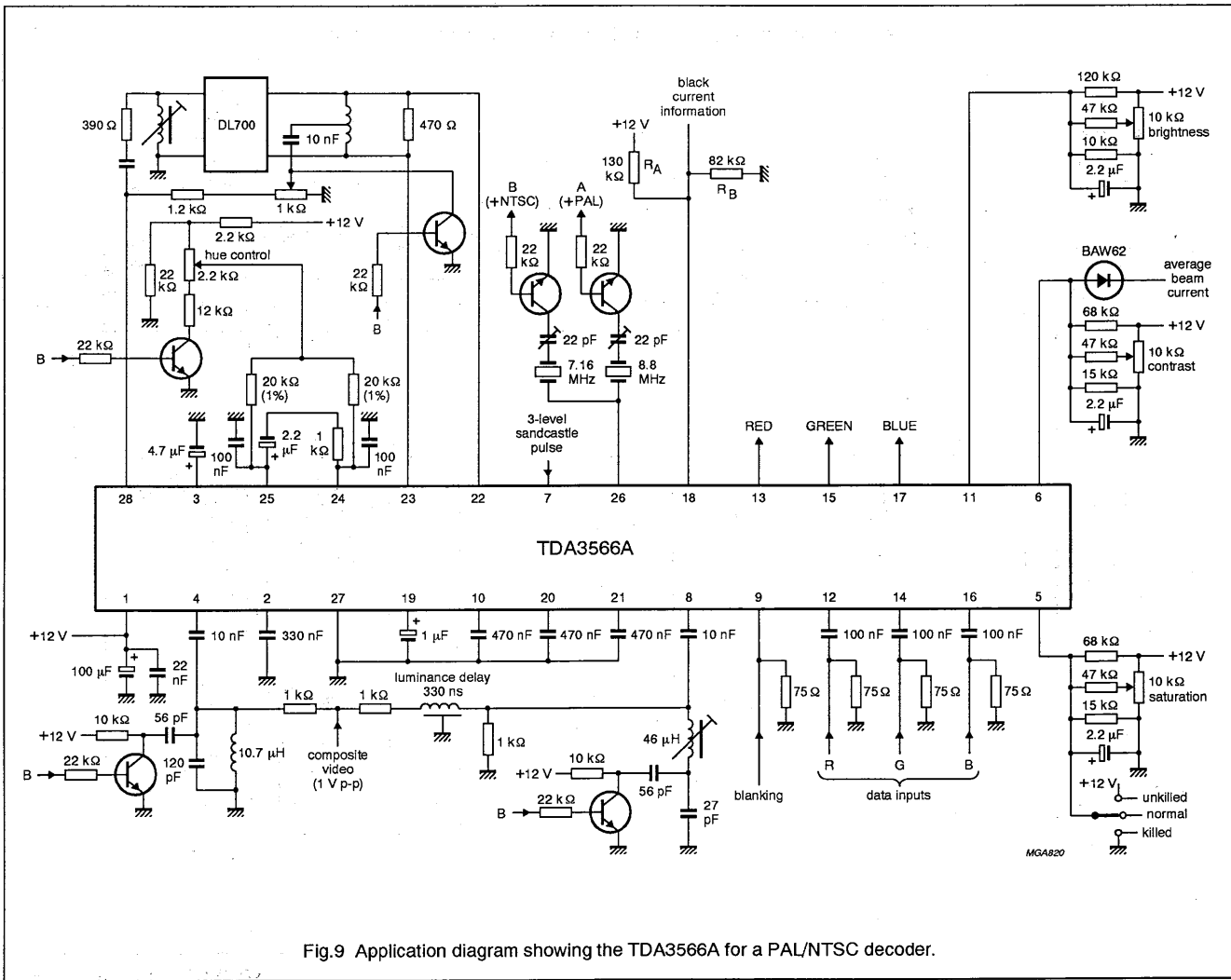

Fig.9 Application diagram showing the TDA3566A for a PAL/NTSC decoder.

PAL/NTSC decoder

TDA3566A

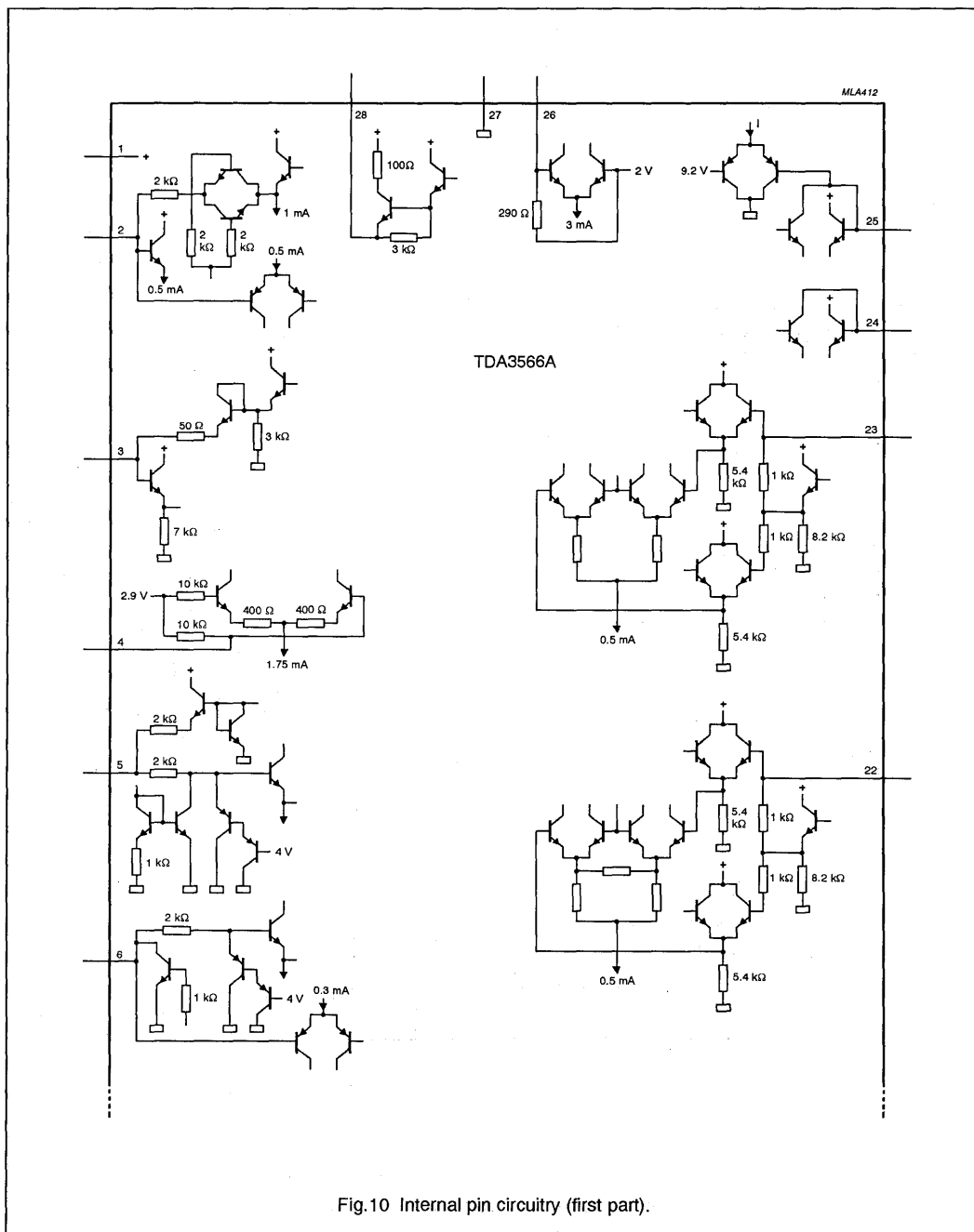

Fig.10 Internal pin circuitry (first part).

PAL/NTSC decoder

TDA3566A

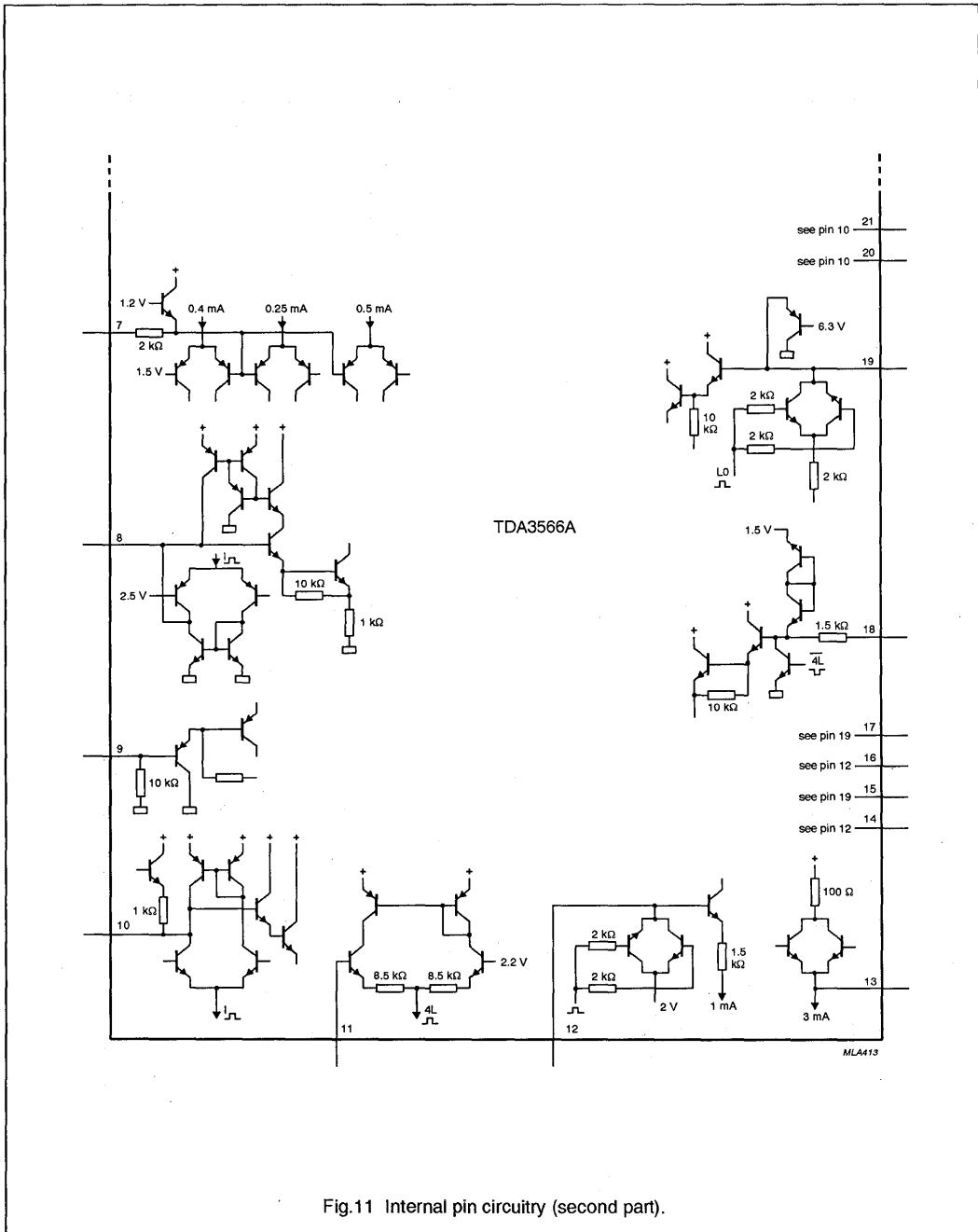

Fig.11 Internal pin circuitry (second part).



## Baseband delay line

TDA4665

## FEATURES

- Two comb filters, using the switched-capacitor technique, for one line delay time (64  $\mu$ s)
- Adjustment-free application
- No crosstalk between SECAM colour carriers (diaphoty)
- Handles negative or positive colour-difference input signals
- Clamping of AC-coupled input signals ( $\pm(R-Y)$  and  $\pm(B-Y)$ )
- VCO without external components
- 3 MHz internal clock signal derived from a 6 MHz CCO, line-locked by the sandcastle pulse (64  $\mu$ s line)
- Sample-and-hold circuits and low-pass filters to suppress the 3 MHz clock signal
- Addition of delayed and non-delayed output signals
- Output buffer amplifiers
- Comb filtering functions for NTSC colour-difference signals to suppress cross-colour.

## GENERAL DESCRIPTION

The TDA4665 is an integrated baseband delay line circuit with one line delay. It is suitable for decoders with colour-difference signal outputs  $\pm(R-Y)$  and  $\pm(B-Y)$ .

## QUICK REFERENCE DATA

SYMBOL	PARAMETER	MIN.	TYP.	MAX.	UNIT
V <sub>P1</sub>	analog supply voltage (pin 9)	4.5	5	6	V
V <sub>P2</sub>	digital supply voltage (pin 1)	4.5	5	6	V
I <sub>p tot</sub>	total supply current	—	5.9	7.0	mA
V <sub>i</sub>	$\pm(R-Y)$ input signal PAL/NTSC (peak-to-peak value, pin 16)	—	525	—	mV
	$\pm(B-Y)$ input signal PAL/NTSC (peak-to-peak value, pin 14)	—	665	—	mV
	$\pm(R-Y)$ input signal SECAM (peak-to-peak value, pin 16)	—	1.05	—	V
	$\pm(B-Y)$ input signal SECAM (peak-to-peak value, pin 14)	—	1.33	—	V
G <sub>v</sub>	gain V <sub>o</sub> / V <sub>i</sub> of colour-difference output signals				
	V <sub>11</sub> / V <sub>16</sub> for PAL and NTSC	5.3	5.8	6.3	dB
	V <sub>12</sub> / V <sub>14</sub> for PAL and NTSC	5.3	5.8	6.3	dB
	V <sub>11</sub> / V <sub>16</sub> for SECAM	-0.6	-0.1	+0.4	dB
	V <sub>12</sub> / V <sub>14</sub> for SECAM	-0.6	-0.1	+0.4	dB

## ORDERING INFORMATION

EXTENDED TYPE NUMBER	PACKAGE			
	PINS	PIN POSITION	MATERIAL	CODE
TDA4665	16	DIL	plastic	SOT38-4
TDA4665T	16	mini-pack	plastic	SOT109A

Baseband delay line

TDA4665

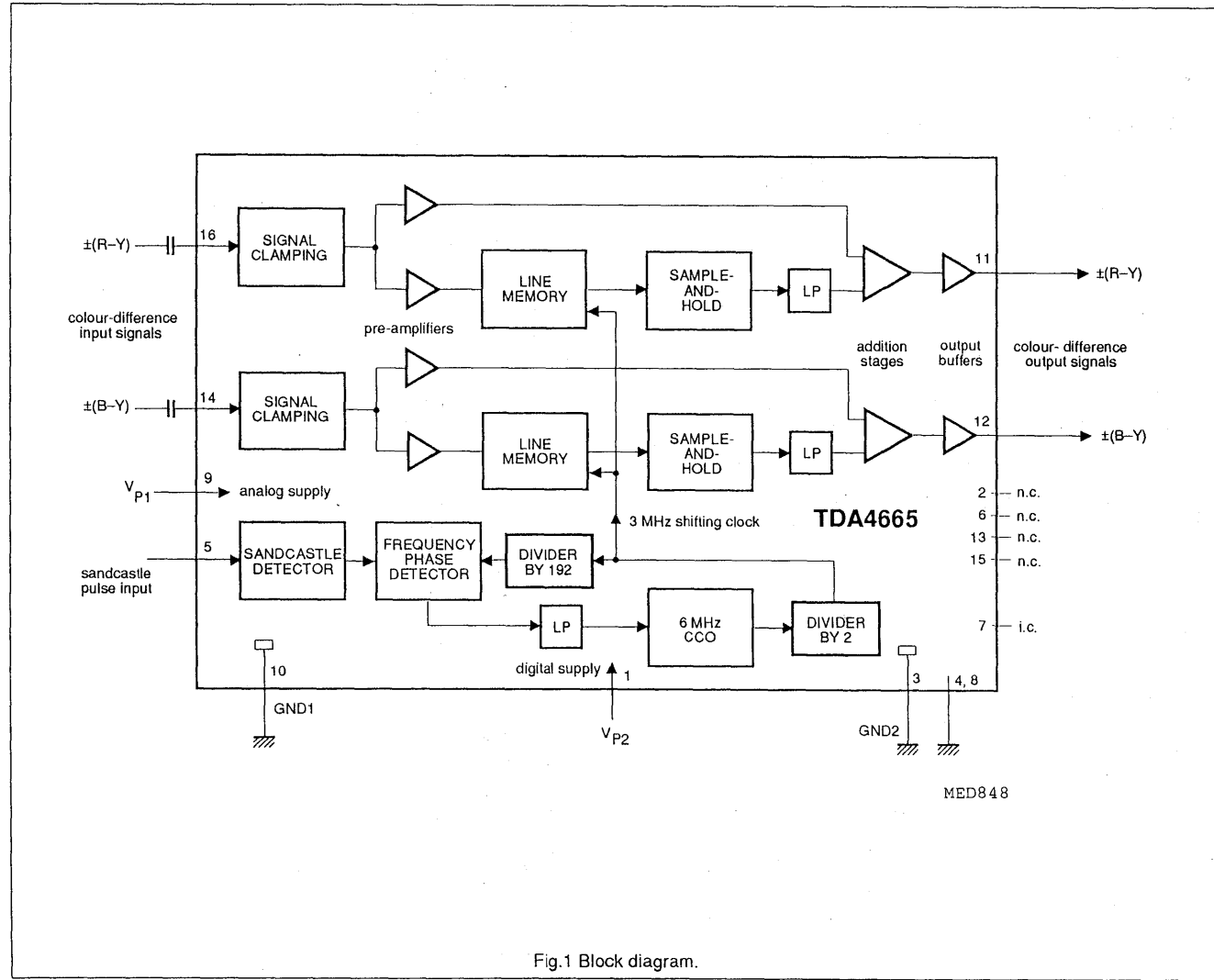

Fig.1 Block diagram.

## Baseband delay line

TDA4665

## PINNING

SYMBOL	PIN	DESCRIPTION
V <sub>P2</sub>	1	+5 V supply voltage for digital part
n.c.	2	not connected
GND2	3	ground for digital part (0 V)
i.c.	4	internally connected
SAND	5	sandcastle pulse input
n.c.	6	not connected
i.c.	7	internally connected
i.c.	8	internally connected
V <sub>P1</sub>	9	+5 V supply voltage for analog part
GND1	10	ground for analog part (0 V)
V <sub>o</sub> (R-Y)	11	±(R-Y) output signal
V <sub>o</sub> (B-Y)	12	±(B-Y) output signal
n.c.	13	not connected
V <sub>i</sub> (B-Y)	14	±(B-Y) input signal
n.c.	15	not connected
V <sub>i</sub> (R-Y)	16	±(R-Y) input signal

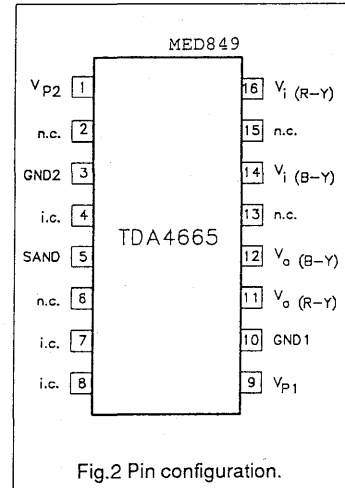

## LIMITING VALUES

In accordance with the Absolute Maximum Rating System (IEC 134).  
Ground pins 3 and 10 connected together.

SYMBOL	PARAMETER	MIN.	MAX.	UNIT
V <sub>P1</sub>	supply voltage (pin 9)	-0.5	+7	V
V <sub>P2</sub>	supply voltage (pin 1)	-0.5	+7	V
V <sub>5</sub>	voltage on pin 5	-0.5	V <sub>P</sub> + 1.0	V
V <sub>n</sub>	voltage on pins 11, 12, 14 and 16	-0.5	V <sub>P</sub>	V
T <sub>stg</sub>	storage temperature	-25	+150	°C
T <sub>amb</sub>	operating ambient temperature	0	+70	°C
V <sub>ESD</sub>	electrostatic handling for all pins (note 1)	-	±500	V

## Note to the Limiting Values

1. Equivalent to discharging a 200 pF capacitor through a 0 Ω series resistor.

## THERMAL RESISTANCE

SYMBOL	PARAMETER	THERMAL RESISTANCE
R <sub>th j-a</sub>	from junction to ambient in free air	
	SOT38-4	75 K/W
	SOT109A	220 K/W

## Baseband delay line

TDA4665

## CHARACTERISTICS

$V_P = 5.0$  V; input signals as specified in characteristics with 75% colour bars; super-sandcastle frequency of 15.625 kHz;  $T_{amb} = +25$  °C, measurements taken in Fig.3 unless otherwise specified.

SYMBOL	PARAMETER	CONDITIONS	MIN.	TYP.	MAX.	UNIT
$V_{P1}$	supply voltage (analog part, pin 9)		4.5	5	6	V
$V_{P2}$	supply voltage (digital part, pin 1)		4.5	5	6	V
$I_{P1}$	supply current		–	5.2	6.0	mA
$I_{P2}$	supply current		–	0.7	1.0	mA
<b>Colour-difference input signals</b>						
$V_i$	input signal (peak-to-peak value; note 1)					
	$\pm(R-Y)$ PAL and NTSC (pin 16)		–	525	–	mV
	$\pm(B-Y)$ PAL and NTSC (pin 14)		–	665	–	mV
	$\pm(R-Y)$ SECAM (pin 16)		–	1.05	–	V
	$\pm(B-Y)$ SECAM (pin 14)		–	1.33	–	V
$V_{i\max}$	maximum symmetrical input signal (peak-to-peak value)					
	$\pm(R-Y)$ or $\pm(B-Y)$ for PAL and NTSC	before clipping	1	–	–	V
	$\pm(R-Y)$ or $\pm(B-Y)$ for SECAM	before clipping	2	–	–	V
$R_{14, 16}$	input resistance		–	–	40	k $\Omega$
$C_{14, 16}$	input capacitance		–	–	10	pF
$V_{14, 16}$	input clamping voltage	proportional to $V_P$	1.3	1.5	1.7	V
<b>Colour-difference output signals</b>						
$V_o$	output signal (peak-to-peak value)					
	$\pm(R-Y)$ on pin 11	all standards	–	1.05	–	V
	$\pm(B-Y)$ on pin 12	all standards	–	1.33	–	V
$V_{11}/V_{12}$	ratio of output amplitudes at equal input signals	$V_{i\ 14, 16} = 1.33$ V (p-p)	–0.4	0	+0.4	dB
$V_{11, 12}$	DC output voltage	proportional to $V_P$	2.90	3.10	3.30	V
$R_{11, 12}$	output resistance		–	330	400	$\Omega$
$G_v$	gain for PAL and NTSC	ratio $V_o/V_i$	5.3	5.8	6.3	dB
	gain for SECAM	ratio $V_o/V_i$	–0.6	–0.1	+0.4	dB
$V_n/V_{n+1}$	ratio of output signals on pins 11 and 12 for adjacent time samples at constant input signals	$V_{i\ 14, 16} = 1.33$ V (p-p); SECAM signals	–0.1	0	+0.1	dB
$V_n$	noise voltage (RMS value, pins 11 and 12)	$V_{i\ 14, 16} = 0$ V; note 2	–	–	1.2	mV
$S/N(W)$	weighted signal-to-noise ratio	$V_o = 1$ V (p-p); $f = tbn$	–	54	–	dB
$t_d$	delay of delayed signals		63.94	64.0	64.06	$\mu$ s
	delay of non-delayed signals		40	60	80	ns
$t_{tr}$	transient time of delayed signal on pins 11 respectively 12	300 ns transient of SECAM signal	–	350	–	ns
	transient time of non-delayed signal on pins 11 respectively 12	300 ns transient of SECAM signal	–	320	–	ns

## Baseband delay line

TDA4665

SYMBOL	PARAMETER	CONDITIONS	MIN.	TYP.	MAX.	UNIT
<b>Sandcastle pulse input (pin 5)</b>						
$f_{BK}$	burst-key frequency / sandcastle frequency		14.2	15.625	17.0	kHz
$V_5$	top pulse voltage	note 3	4.0	–	$V_P + 1.0$	V
$V_{slice}$	internal slicing level		$V_5 - 1.0$	–	$V_5 - 0.5$	V
$I_5$	input current		–	–	10	$\mu A$
$C_5$	input capacitance		–	–	10	pF

**Notes to the characteristics**

- For SECAM the signal must be blanked line-sequentially. The blanking level must be equal to the non-colour signal. For SECAM, PAL and NTSC the input signal must be equal to the non-colour signal during the internal clamping of TDA4665 (3  $\mu s$  to 1  $\mu s$  before the leading edge of the top pulse of  $V_5$ ).
- Noise voltage at  $f = 10$  kHz to 1 MHz;  $V_{i 14, 16} = 0$  ( $R_S < 300 \Omega$ ).
- The leading edge of the burst-key pulse or top pulse is used for timing.

Baseband delay line

TDA4665

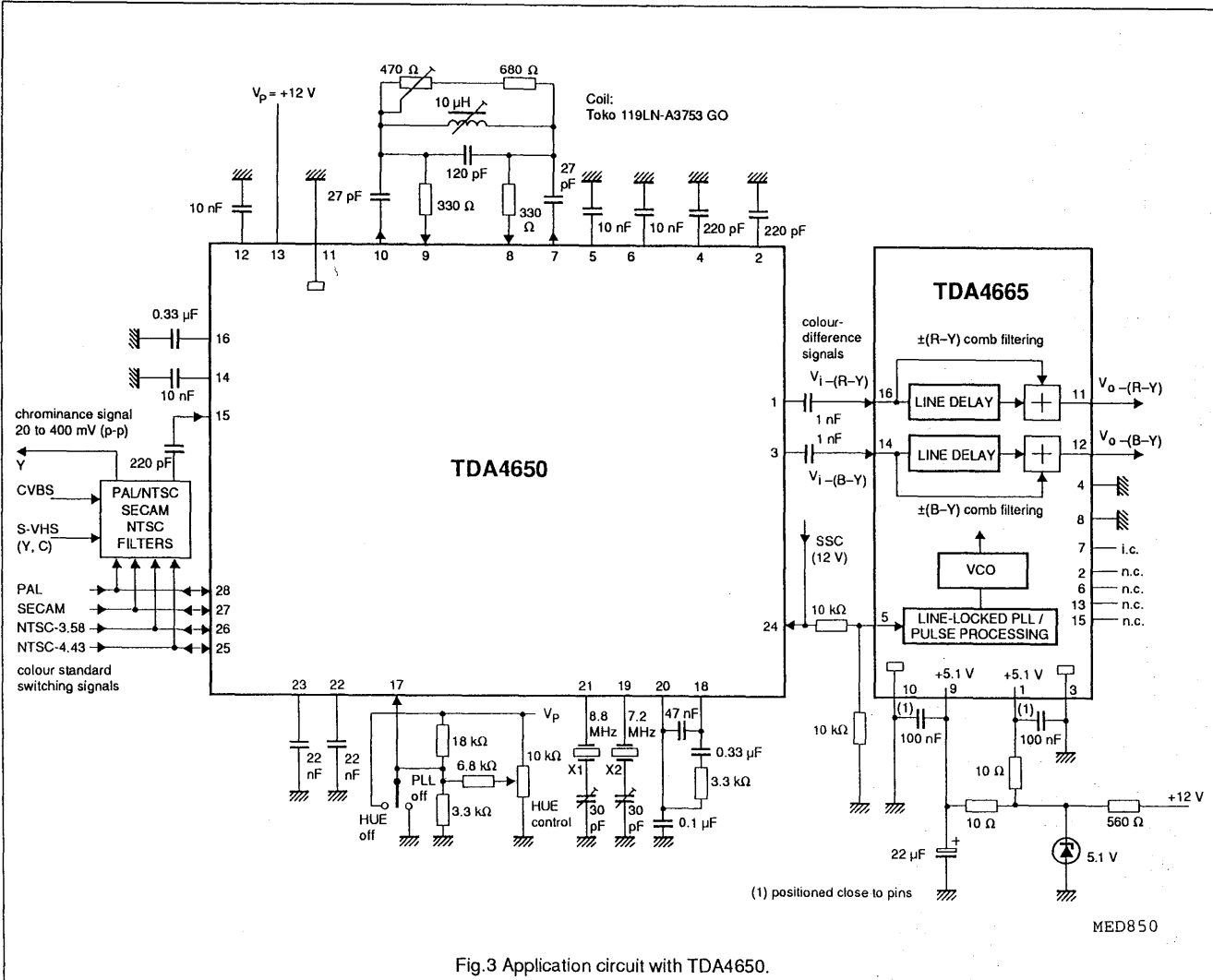

Fig.3 Application circuit with TDA4650.

MED850

## Picture signal improvement (PSI) circuit

TDA4670



## FEATURES

- Luminance signal delay from 20 ns up to 1100 ns (minimum step 45 ns)
- Luminance signal peaking with symmetrical overshoots selectable
- 2.6 or 5 MHz peaking centre frequency and degree of peaking selectable (-3, 0, +3 and +6 dB)
- Noise reduction by coring selectable
- Handles negative as well as positive colour-difference signals
- Colour transient improvement (CTI) selectable to decrease the colour-difference signal transient times to those of the high frequency luminance signals
- 5 or 12 V sandcastle input voltage selectable
- All controls selected via the I<sup>2</sup>C-bus
- Timing pulse generation for clamping and delay time control synchronized by sandcastle pulse
- Automatic luminance signal delay correction using a control loop
- Luminance and colour-difference input signal clamping with coupling-capacitor
- +4.5 to 8.8 V supply voltage range
- Minimum of external components

## GENERAL DESCRIPTION

The TDA4670 delays the luminance signal and improves colour-difference signal transients. Additional, the luminance signal can be improved by peaking and noise reduction (coring).

## QUICK REFERENCE DATA

SYMBOL	PARAMETER	MIN.	TYP.	MAX.	UNIT
$V_P$	supply voltage (pins 1 and 5)	4.5	5	8.8	V
$I_P$	total supply current	31	41	52	mA
$t_{dY}$	Y signal delay time	20	-	1130	ns
$V_{iVBS}$	composite Y input signal (peak-to-peak value, pin 16)	-	450	640	mV
$V_{iCD}$	colour-difference input signal (peak-to-peak value)				
	$\pm(R-Y)$ on pin 3	-	1.05	1.48	V
	$\pm(B-Y)$ on pin 7	-	1.33	1.88	V
$G_Y$	gain of Y channel	-	-1	-	dB
$G_{CD}$	gain of colour-difference channel	-	0	-	dB
$T_{amb}$	operating ambient temperature range	0	-	70	°C

## ORDERING INFORMATION

EXTENDED TYPE NUMBER	PACKAGE			
	PINS	PIN POSITION	MATERIAL	CODE
TDA4670	18	DIL	plastic	SOT102

Picture signal improvement (PSI)  
circuit

TDA4670

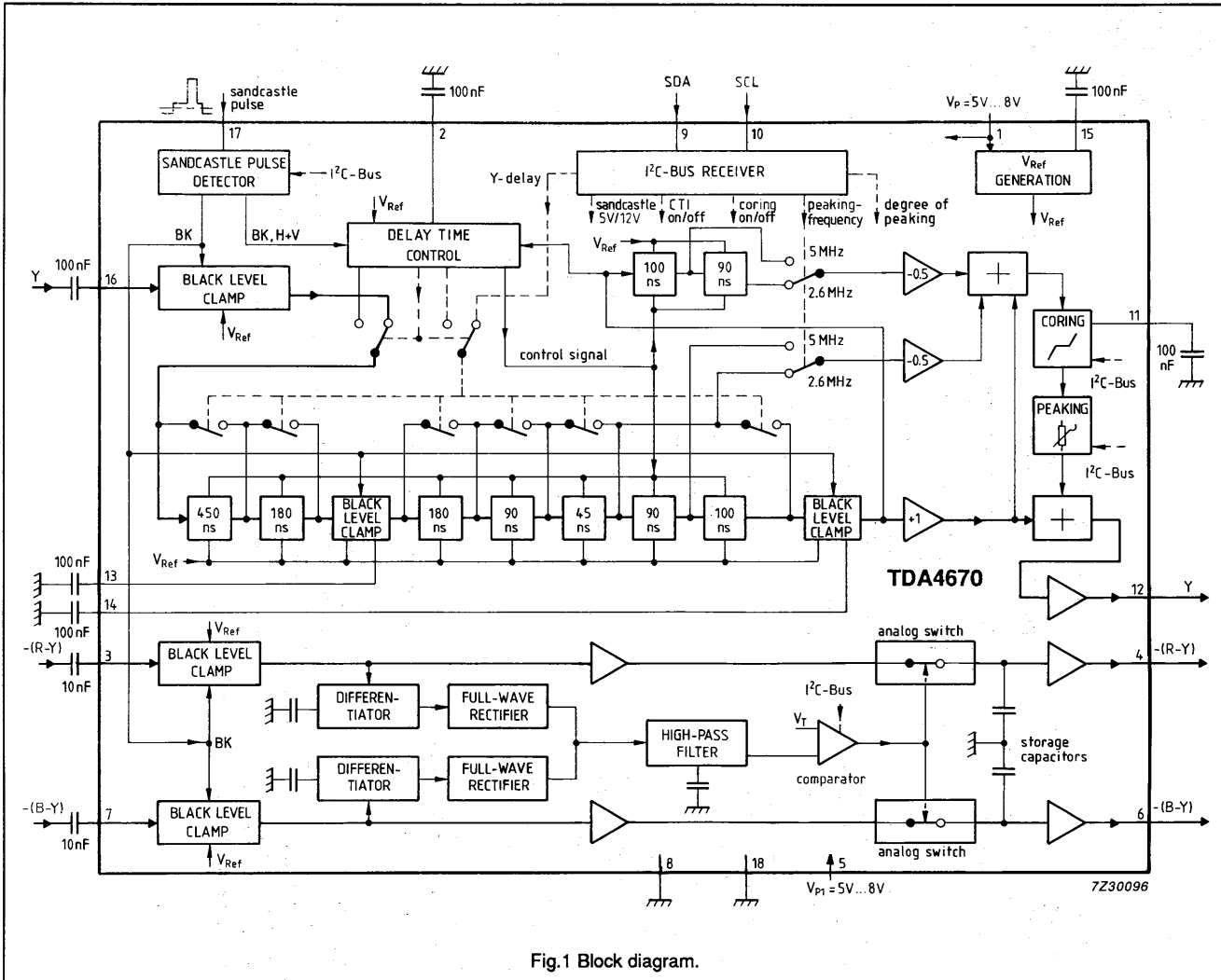

Fig.1 Block diagram.



# Picture signal improvement (PSI) circuit

TDA4670

## PINNING

SYMBOL	PIN	DESCRIPTION
V <sub>P1</sub>	1	positive supply voltage 1
C <sub>DL</sub>	2	capacitor of delay time control
V <sub>i(R-Y)</sub>	3	$\pm(R-Y)$ colour-difference input signal
V <sub>o(R-Y)</sub>	4	$\pm(R-Y)$ colour-difference output signal
V <sub>P2</sub>	5	positive supply voltage 2
V <sub>o(B-Y)</sub>	6	$\pm(B-Y)$ colour-difference output signal
V <sub>i(B-Y)</sub>	7	$\pm(B-Y)$ colour-difference input signal
GND2	8	ground 2 (0 V)
SDA	9	I <sup>2</sup> C-bus data line
SCL	10	I <sup>2</sup> C-bus clock line
C <sub>COR</sub>	11	coring capacitor
V <sub>oY</sub>	12	delayed luminance output signal
C <sub>CLP1</sub>	13	black level clamping capacitor 1
C <sub>CLP2</sub>	14	black level clamping capacitor 2
C <sub>ref</sub>	15	capacitor of reference voltage
V <sub>iY</sub>	16	luminance input signal
SAND	17	sandcastle pulse input
GND1	18	ground 1 (0 V)

## PIN CONFIGURATION

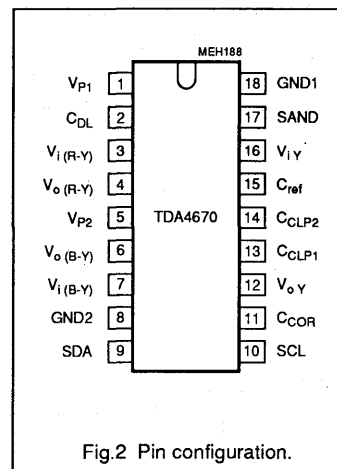

## FUNCTIONAL DESCRIPTION

The TDA4670 contains luminance signal processing and colour-difference signal processing. The luminance signal section comprises a variable, integrated luminance delay line with luminance signal peaking and a noise reduction by coring. The colour-difference section consists of a transient improvement circuit to decrease the rise and fall times of the colour-difference signal transients. All functions and parameters are controlled via the I<sup>2</sup>C-bus.

## Y-signal path

The video and blanking signal is AC-coupled to the input pin 16. Its

black porch is clamped to a DC reference voltage to ensure fitting to the operating range of the luminance delay stage.

The luminance delay line consists of all-pass filter sections with delay times of 45, 90, 100, 180 and 450 ns (Fig. 1). The luminance signal delay is controlled via the I<sup>2</sup>C-bus in steps of 45 ns in the range of 20 to 1100 ns, this ensures that the maximum delay difference between the luminance and colour-difference signals is  $\pm 22.5$  ns.

An automatic luminance delay time adjustment in an internal control loop (with the horizontal frequency as a reference) is used to correct changes in the delay time, due to component tolerances. The control loop is

automatically enabled between the burst-key pulses of lines 16 (330) and 17 (331) during the vertical blanking interval. The control voltage is stored in the capacitor C<sub>DL</sub> at pin 2.

The peaking section is using a transversal filter circuit with selectable centre frequencies of 2.6 and 5.0 MHz.

It provides selectable degrees of peaking of -3, 0, +3 and +6 dB and a noise reduction by coring, which attenuates the high-frequency noise introduced by peaking.

The output buffer stage ensures a low-ohmic VBS output signal on pin 12 (< 160  $\Omega$ ). The gain of the luminance signal path from pin 16 to pin 12 is unity.

## Picture signal improvement (PSI) circuit

TDA4670

An oscillation signal of the delay time control loop is present on output pin 12 instead of the VBS signal during the vertical blanking interval in lines 16 (330) to 18 (332). Therefore, this output signal should not be applied for synchronization.

### Colour-difference signal paths

The colour-difference input signals (on pins 3 and 7) are clamped to a reference voltage.

Each colour-difference signal is fed to a transient detector and to an analog signal switch with an attached voltage storage stage.

The transient detectors consist of differentiators and full-wave rectifiers. The output voltages of both transient detectors are added and then compared in a comparator. This comparator controls both following analog signal switches simultaneously. The analog signal switches are in open position at a certain value of transient time; then the held value

(held by storage capacitors) is applied to the outputs. The switches close to accept rapidly the actual signal levels at the end of these transients. The improved transient time is approximately 100 ns long independent of the input signal transient time.

Colour-difference paths are independent of the input signal polarity and have a gain of unity.

The CT1 functions are switched on and off via the I<sup>2</sup>C-bus.

### LIMITING VALUES

In accordance with the Absolute Maximum System (IEC 134),  $V_{P1}$  and  $V_{P2}$  as well as GND1 and GND 2 connected together.

SYMBOL	PARAMETER	MIN.	MAX.	UNIT
$V_{P1}$	supply voltage (pin 1)	0	8.8	V
$V_{P2}$	supply voltage (pin 5)	0	8.8	V
$P_{tot}$	total power dissipation	0	0.97	W
$T_{stg}$	storage temperature range	-25	150	°C
$T_{amb}$	operating ambient temperature range	0	70	°C
$V_{ESD}$	electrostatic handling* for pins 9 and 10  for other pins	-	+300	V
		-	-500	V
		-	±500	V

### THERMAL RESISTANCE

SYMBOL	PARAMETER	MIN.	MAX.	UNIT
$R_{th\ j-a}$	from junction-to-ambient in free air	-	82	K/W

\* Equivalent to discharging a 200 pF capacitor through a 0  $\Omega$  series resistor.

# Picture signal improvement (PSI) circuit

TDA4670

## CHARACTERISTICS

$V_{P1} = V_{P2} = 5\text{ V}$ ; nominal video amplitude  $V_{VB} = 315\text{ mV}$ ;  $t_H = 64\text{ }\mu\text{s}$ ;  $t_{BK} = 4\text{ }\mu\text{s}$  (burst key);  $T_{amb} = 25\text{ }^\circ\text{C}$  and measurements taken in Fig.3 unless otherwise specified.

SYMBOL	PARAMETER	CONDITIONS	MIN.	TYP.	MAX.	UNIT
$V_{P1}$	supply voltage range (pin 1)		4.5	5	8.8	V
$V_{P2}$	supply voltage range (pin 5)		4.5	5	8.8	V
$I_P$	total supply current		31	41	52	mA
<b>Y-signal path</b>						
$V_{iY}$	VBS input signal on pin 16 (peak-to-peak value)		-	450	640	mV
$V_{16}$	black level clamping voltage		-	3.1	-	V
$I_{16}$	input current	during clamping	$\pm 95$	-	$\pm 190$	$\mu\text{A}$
		outside clamping	-	-	$\pm 0.1$	$\mu\text{A}$
$R_{16}$	input resistance	outside clamping	5	-	-	M $\Omega$
$C_{16}$	input capacitance		-	3	10	pF
$t_{dY}$	maximum Y delay time minimum Y delay time	set via I <sup>2</sup> C-bus	1070	1100	1130	ns
			-	20	-	ns
$\Delta t_{dY}$	minimum delay step group delay time difference  delay time difference between Y and colour-difference signals	set via I <sup>2</sup> C-bus	40	45	50	ns
		$f = 0.5\text{ to }5\text{ MHz}$ maximum delay	-	0	$\pm 25$	ns
		Y delay; CTI and peaking off	70	100	130	ns
$t_{d\text{ peak}}$	minimum delay time for peaking		185	215	245	ns
$G_Y$	VBS signal gain measured on output pin 12 (composite signal, peak-to-peak value)	$V_o / V_i$ ; $f = 500\text{ kHz}$ ; maximum delay	-2	-1	0	dB
$I_{12}$	output current (emitter-follower with constant current source)	source current	-1	-	-	mA
		sink current	0.4	-	-	mA
$R_{12}$	output resistance		-	-	160	$\Omega$
$f$	frequency response for $f = 0.5\text{ to }3\text{ MHz}$ $f = 0.5\text{ to }5\text{ MHz}$	maximum delay	-2	-1	0	dB
			-4	-3	-1	dB
LIN	signal linearity for video contents of 315 mV (p-p) video contents of 450 mV (p-p)	$a_{min} / a_{max}$				
		$V_{VBS} = 450\text{ mV (p-p)}$	0.85	-	-	-
		$V_{VBS} = 640\text{ mV (p-p)}$	0.60	-	-	-

# Picture signal improvement (PSI) circuit

TDA4670

SYMBOL	PARAMETER	CONDITIONS	MIN.	TYP.	MAX.	UNIT
<b>Luminance peaking, selected via I<sup>2</sup>C-bus</b>						
f <sub>peak</sub>	peaking frequency	f <sub>C1</sub> ; LCF-bit = 0	4.5	5	5.5	MHz
		f <sub>C2</sub> ; LCF-bit = 1	2.3	2.6	2.9	MHz
V <sub>peak</sub>	peaking amplitude for grade of peaking (f <sub>C</sub> amplitude over 0.5 MHz amplitude) selectable values		-	-3	-	dB
				0	-	dB
				+3	-	dB
				+6	-	dB
	limitation of peaking (positive amplitude of correction signal referred to 315 mV)		-	20	-	%
V <sub>n</sub>	noise voltage on pin 12 (RMS value)	without peaking f = 0 to 5 MHz	-	-	1	mV
COR	coring of peaking (coring part referred to 315 mV)	COR-bit = 1	-	20	-	%
<b>Colour-difference paths</b> measured with transient times t <sub>r</sub> = t <sub>f</sub> = 1 μs; t <sub>p</sub> H ≥ 1 μs; V <sub>i</sub> = 1.33 V (p-p) on pins 3 and 7 and with burst key pulse t <sub>BK</sub> = 4 μs.						
V <sub>i CD</sub>	±(R-Y) input signal (peak-to-peak values, pin 3)	75% colour bar;	-	1.05	1.48	V
	±(B-Y) input signal (peak-to-peak values, pin 7)	75% colour bar	-	1.33	1.88	V
	input transient sensitivity	V <sub>3,7</sub> / dt	0.15	-	-	V/μs
V <sub>3,7</sub>	internal clamping voltage level		-	2.45	-	V
I <sub>3,7</sub>	input current	outside clamping during clamping	- ±100	- -	±1 ±190	μA μA
C <sub>3,7</sub>	input capacitance		-	6	12	pF
V <sub>4,6</sub>	DC output voltage		-	2	-	V
ΔV <sub>4,6</sub>	output offset voltage	R <sub>S</sub> ≤ 300 Ω; note 1 during and after storage time	-	-	±5	mV
			-	-	±18	mV
V <sub>spike</sub>	spurious spike signals on pins 4 and 6	R <sub>S</sub> ≤ 300 Ω; note 1	-	-	±30	mV
I <sub>4,6</sub>	output current (emitter-follower with constant current source)	source current	-1	-	-	mA
		sink current	0.4	-	-	mA
R <sub>4,6</sub>	output resistance		-	-	100	Ω
G <sub>v</sub>	signal gain in each path	V <sub>o</sub> / V <sub>i</sub>	-1	0	+1	dB
ΔG <sub>v</sub>	gain difference -(R-Y) / -(B-Y)		-	0	±0.3	dB

# Picture signal improvement (PSI) circuit

TDA4670

SYMBOL	PARAMETER	CONDITIONS	MIN.	TYP.	MAX.	UNIT
LIN	signal linearity	$a_{\min} / a_{\max}$				
	for nominal signal	$V_i = 1.33 \text{ V (p-p)}$	0.90	-	-	
	for +3 dB signal	$V_i = 1.88 \text{ V (p-p)}$	0.65	-	-	
$\Delta V_o$	signal reduction at higher frequency (output signal ratio $V_i / V_o$ )	signal with $t_{pH} = 50 \text{ ns};$ $t_r = t_f = 1 \mu\text{s}$	-1.5	-	-	dB
<b>Sandcastle pulse, input voltage selectable via I<sup>2</sup>C-bus</b>						
V <sub>17</sub>	input voltage threshold for H and V sync	SC5-bit = 0 (12 V)	1.1	1.5	1.9	V
	input voltage threshold for burst	SC5-bit = 0 (12 V)	5.5	6.5	7.5	V
	input voltage threshold for H and V sync	SC5-bit = 1 (5 V)	1.1	1.5	1.9	V
	input voltage threshold for burst	SC5-bit = 1 (5 V)	3.0	3.5	4.0	V
R <sub>17</sub>	input resistance	12 V input level	30	40	50	k $\Omega$
		5 V input level	15	20	25	k $\Omega$
C <sub>17</sub>	input capacitance		-	4	8	pF
t <sub>BK</sub>	burst-key pulse width		3.0	4.0	4.6	$\mu\text{s}$
t <sub>d</sub>	leading edge delay for clamping pulse	referred to t <sub>BK</sub>	-	1	-	$\mu\text{s}$
n <sub>p</sub>	number of required burst-key pulses vertical blanking interval	note 2	4	-	31	
<b>I<sup>2</sup>C-bus control, SDA and SCL</b>						
V <sub>IH</sub>	input voltage HIGH on pins 9 and 10		3	-	5	V
V <sub>IL</sub>	input voltage LOW		0	-	1.5	V
I <sub>9,10</sub>	input current		-	-	$\pm 10$	$\mu\text{A}$
V <sub>9</sub>	output voltage at acknowledge on pin 9	I <sub>9</sub> = 3 mA	-	-	0.4	V
I <sub>ACK</sub>	output current at acknowledge on pin 9	sink current	3	-	-	mA

### Notes to the characteristics

- Crosstalk on output, measured in the unused channel when the other channel is provided with a nominal input signal (CTI active).
- A number of more than 31 burst-key pulses repeats the counter cycle of delay time control.

**Picture signal improvement (PSI)  
circuit**

**TDA4670**

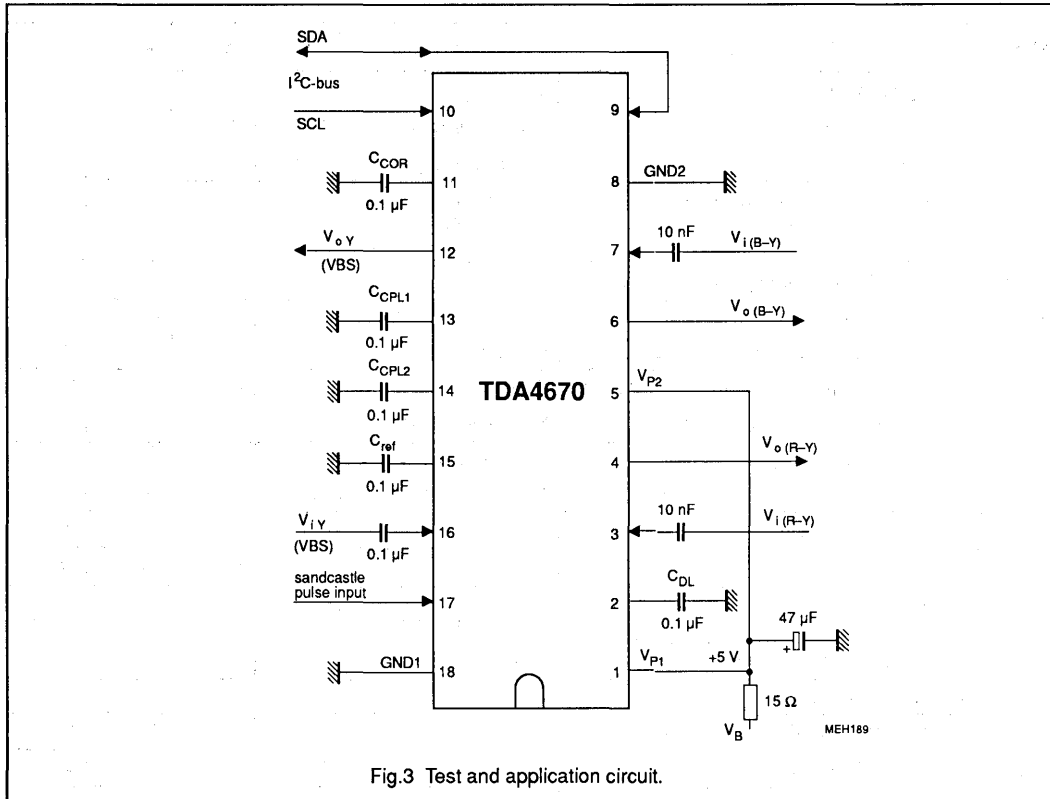

Fig.3 Test and application circuit.

**I<sup>2</sup>C-BUS FORMAT**

S	SLAVE ADDRESS	A	SUBADDRESS	A	DATA	P
---	---------------	---	------------	---	------	---

- S = start condition
- SLAVE ADDRESS = 1000 100X
- A = acknowledge, generated by the slave
- SUBADDRESS = subaddress byte, Table 1
- DATA = data byte, Table 1
- P = stop condition
  
- X = read/write control bit
- X = 0, to write (the circuit is slave receiver only)

If more than 1 byte DATA are transmitted, then auto-increment of the subaddress is performed.

# Picture signal improvement (PSI) circuit

## TDA4670

Table 1 I<sup>2</sup>C-bus transmission

function	subaddress byte	data byte							
		D7	D6	D5	D4	D3	D2	D1	D0
Y delay / CTI / SC	0 0 0 1 0 0 0 0	0	SC5	CTI	DL4	DL3	DL2	DL1	DL0
peaking and coring	0 0 0 1 0 0 0 1	COR	PEAK	LCF	0	0	0	PCON1	PCON0

### Function of the bits:

DL0	set delay in luminance channel:	1 = 45 ns;	0 = 0 ns	
DL1		1 = 90 ns;	0 = 0 ns	
DL2		1 = 180 ns;	0 = 0 ns	
DL3		1 = 180 ns;	0 = 0 ns	
DL4		1 = 450 ns;	0 = 0 ns	
CTI	set colour transient improvement:	1 = active	0 = inactive	
SC5	select sandcastle pulse voltage:	1 = 5 V	0 = 12 V	
LCF	set peaking frequency response:	1 = 2.6 MHz	0 = 5.0 MHz	
PEAK	set peaking delay:	1 = active	0 = inactive	
COR	set coring control:	1 = active	0 = inactive	
PCON	set peaking amplification:	PCON1	PCON0	grade of peaking
		0	0	-3 dB
		0	1	0 dB
		1	0	+3 dB
		1	1	+6 dB

### Remarks to the subaddress bytes

Hex subaddresses 00 to 0F are reserved for colour decoders and RGB processors.

Subaddresses 10 and 11 only are acknowledged.

General call address is not acknowledged.

Power-on reset: D7 to D1 bits of data bytes are set to 0, D0 bit is set to 1.

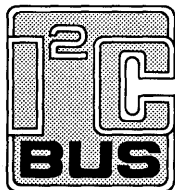

Purchase of Philips' I<sup>2</sup>C components conveys a license under the Philips' I<sup>2</sup>C patent to use the components in the I<sup>2</sup>C-system provided the system conforms to the I<sup>2</sup>C specifications defined by Philips.

# Picture signal improvement (PSI) circuit

## TDA4670

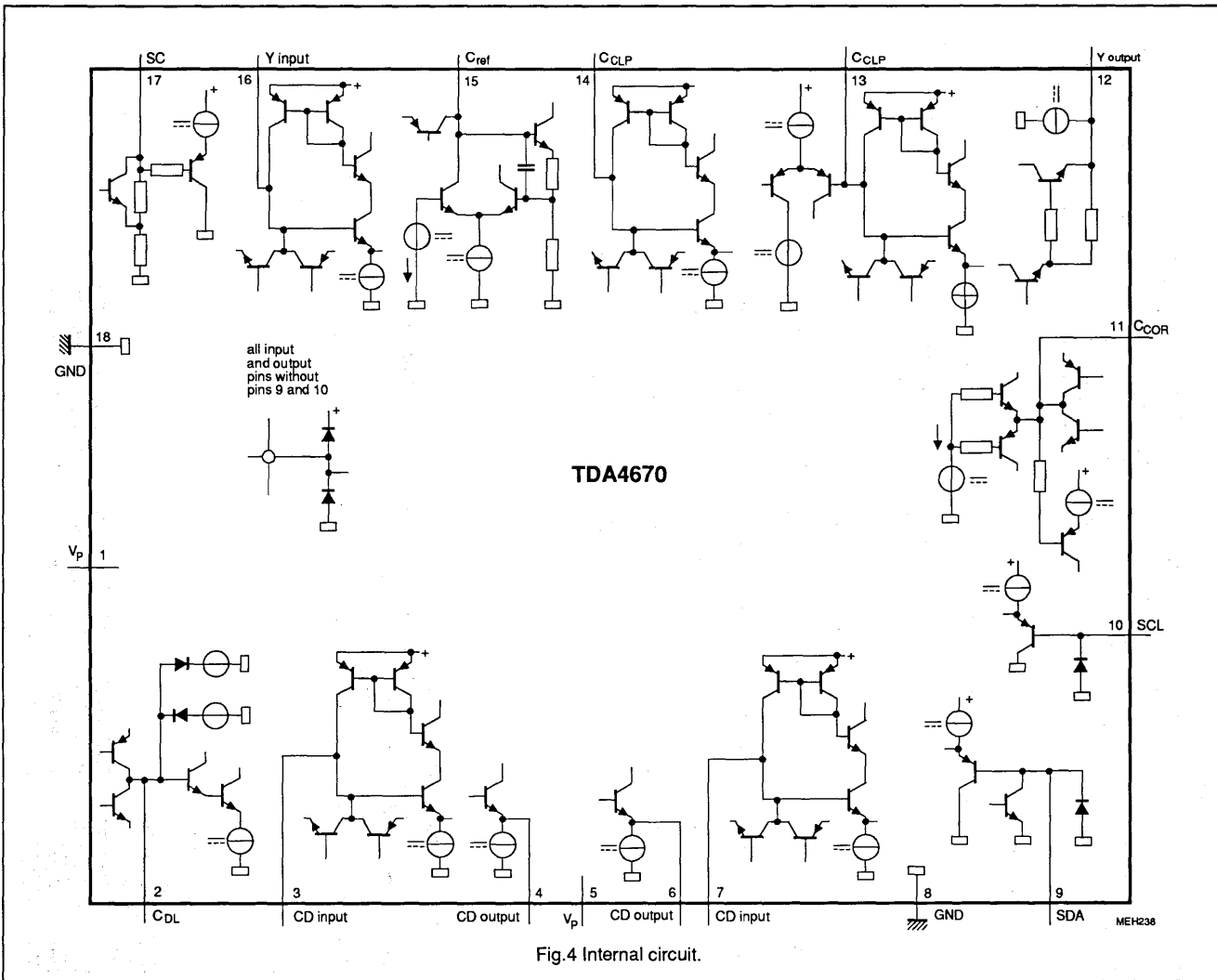

Fig.4 Internal circuit.



# Video processor with automatic cut-off and white level control

TDA4680

## FEATURES

- Operates from an 8 V DC supply
- Black level clamping of the colour difference, luminance and RGB input signals with coupling-capacitor DC level storage
- Two fully-controlled, analog RGB inputs, selected either by fast switch signals or via I<sup>2</sup>C-bus
- Saturation, contrast and brightness adjustment via I<sup>2</sup>C-bus
- Same RGB output black levels for Y/CD and RGB input signals
- Timing pulse generation from either a 2- or 3-level sandcastle pulse for clamping, horizontal and vertical synchronization, cut-off and white level timing pulses
- Automatic cut-off control with picture tube leakage current compensation
- Software-based automatic white level control or fixed white levels via I<sup>2</sup>C-bus
- Cut-off and white level measurement pulses in the last 4 lines of the vertical blanking interval (I<sup>2</sup>C-bus selection for PAL, SECAM, or NTSC, PAL-M)
- Increased RGB signal bandwidths for progressive scan and 100 Hz operation (selected via I<sup>2</sup>C-bus)
- Two switch-on delays to prevent discolouration before steady-state operation
- Average beam current and peak drive limiting
- PAL/SECAM or NTSC matrix selection via I<sup>2</sup>C-bus
- Three adjustable reference voltage levels (via I<sup>2</sup>C-bus) for automatic cut-off and white level control
- Emitter-follower RGB output stages to drive the video output stages
- Hue control output for the TDA4555, TDA4650/T, TDA4655/T or TDA4657.

There is a very similar IC TDA4681 available. The only differences are in the NTSC matrix.

## GENERAL DESCRIPTION

The TDA4680 is a monolithic integrated circuit with a colour difference interface for video processing in TV receivers. Its primary function is to process the luminance and colour difference signals from multistandard colour decoders, TDA4555, TDA4650/T, TDA4655/T or TDA4657, Colour Transient Improvement (CTI) IC, TDA4565, Picture Signal Improvement (PSI) IC, TDA4670, or from a Feature Module.

The required input signals are:

- luminance and negative colour difference signals
- 2- or 3-level sandcastle pulse for internal timing pulse generation

– I<sup>2</sup>C-bus data and clock signals for microprocessor control.

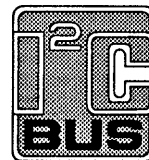

Two sets of analog RGB colour signals can also be inserted, e.g. one from a peritelelevision connector and the other from an on-screen display generator; both inputs are fully-controlled internally. The TDA4680 includes full I<sup>2</sup>C-bus control of all parameters and functions with automatic cut-off and white level control of the picture tube cathode currents. It provides RGB output signals for the video output stages.

## QUICK REFERENCE DATA

SYMBOL	PARAMETER	MIN.	TYP.	MAX.	UNIT
V <sub>P</sub>	supply voltage (pin 5)	7.2	8.0	8.8	V
I <sub>P</sub>	supply current (pin 5)	–	85	–	mA
V <sub>8(p-p)</sub>	luminance input (peak-to-peak value)	–	0.45	–	V
V <sub>6(p-p)</sub>	–(B–Y) input (peak-to-peak value)	–	1.33	–	V
V <sub>7(p-p)</sub>	–(R–Y) input (peak-to-peak value)	–	1.05	–	V
V <sub>14</sub>	three-level sandcastle pulse				
	H+V	–	2.5	–	V
	H	–	4.5	–	V
	BK	–	8.0	–	V
	two-level sandcastle pulse				
	H+V	–	2.5	–	V
	BK	–	4.5	–	V
V <sub>i</sub>	RGB input signals at pins 2, 3, 4, 10, 11 and 12 (black-to-white value)	–	0.7	–	V
V <sub>o(p-p)</sub>	RGB outputs at pins 24, 22 and 20 (peak-to-peak value)	–	2.0	–	V
T <sub>amb</sub>	operating ambient temperature	0	–	+70	°C

## ORDERING INFORMATION

EXTENDED TYPE NUMBER	PACKAGE			
	PINS	PIN POSITION	MATERIAL	CODE
TDA4680	28	DIL	plastic	SOT117
TDA4680WP	28	PLCC	plastic	SOT261CG

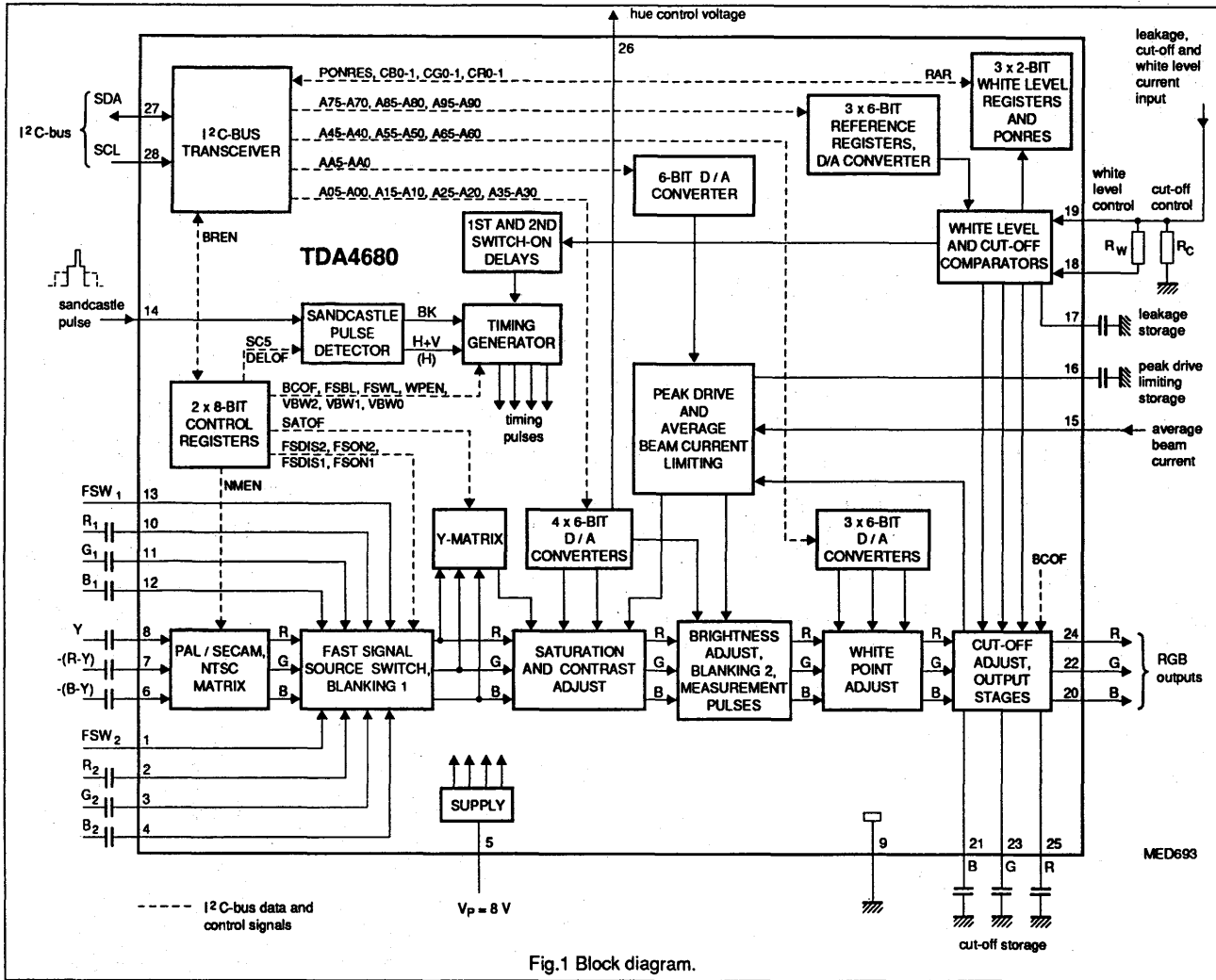

Fig.1 Block diagram.

# Video processor with automatic cut-off and white level control

TDA4680

## PINNING

SYMBOL	PIN	DESCRIPTION
FSW <sub>2</sub>	1	fast switch 2 input
R <sub>2</sub>	2	red input 2
G <sub>2</sub>	3	green input 2
B <sub>2</sub>	4	blue input 2
V <sub>P</sub>	5	supply voltage
-(B-Y)	6	colour difference input -(B-Y)
-(R-Y)	7	colour difference input -(R-Y)
Y	8	luminance input
GND	9	ground
R <sub>1</sub>	10	red input 1
G <sub>1</sub>	11	green input 1
B <sub>1</sub>	12	blue input 1
FSW <sub>1</sub>	13	fast switch 1 input
SC	14	sandcastle pulse input

SYMBOL	PIN	DESCRIPTION
BCL	15	average beam current limiting input
CPDL	16	storage capacitor for peak drive limiting
C <sub>L</sub>	17	storage capacitor for leakage current
WI	18	white level measurement input
CI	19	cut-off measurement input
B <sub>O</sub>	20	blue output
C <sub>B</sub>	21	blue cut-off storage capacitor
G <sub>O</sub>	22	green output
C <sub>G</sub>	23	green cut-off storage capacitor
R <sub>O</sub>	24	red output
C <sub>R</sub>	25	red cut-off storage capacitor
HUE	26	hue control output
SDA	27	I <sup>2</sup> C-bus serial data input/output
SCL	28	I <sup>2</sup> C-bus serial clock input

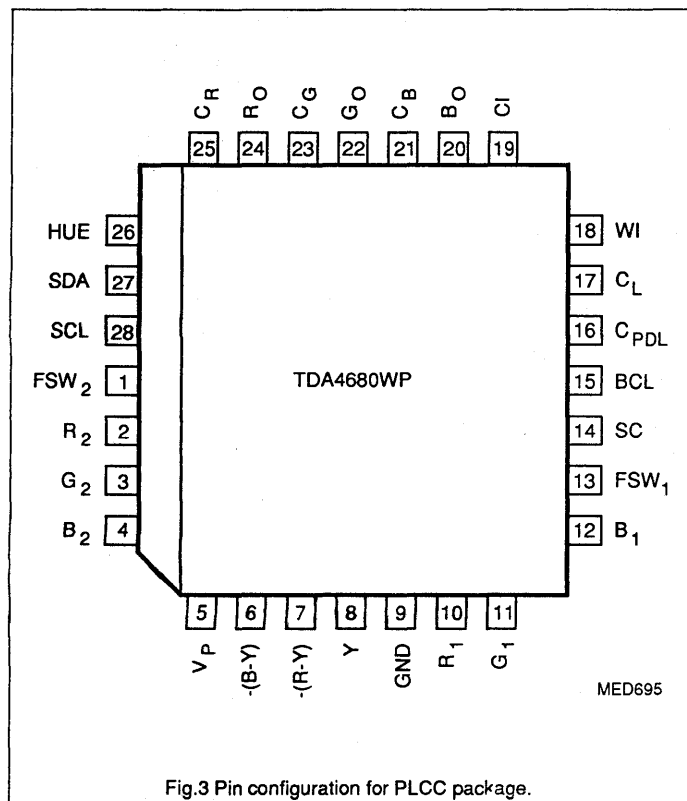
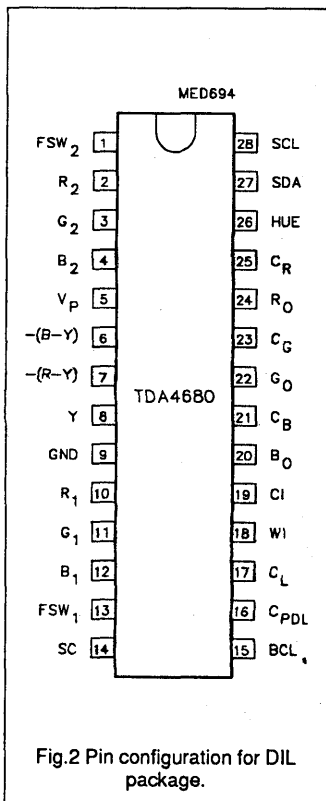

# Video processor with automatic cut-off and white level control

TDA4680

## I<sup>2</sup>C-BUS CONTROL

The I<sup>2</sup>C-bus transmitter/receiver provides the data bytes to select and adjust the following functions and parameters:

- brightness adjust
- saturation adjust
- contrast adjust
- hue control voltage
- RGB gain adjust
- RGB reference voltage levels
- peak drive limiting
- selection of the vertical blanking interval and measurement lines for cut-off and white level control according to transmission standard
- selects either 3-level or 2-level (5 V) sandcastle pulse
- enables/disables input clamping pulse delay
- enables/disables white level control
- enables cut-off control / enables output clamping
- enables/disables full screen white level
- enables/disables full screen black level
- selects either PAL/SECAM or NTSC matrix
- enables saturation adjust / enables nominal saturation
- enables/disables synchronization of the execution of I<sup>2</sup>C-bus commands with the vertical blanking interval
- reads the result of the comparison of the nominal and actual RGB signal levels for automatic white level control.

## I<sup>2</sup>C-BUS TRANSMITTER / RECEIVER AND DATA TRANSFER I<sup>2</sup>C-bus specification

The I<sup>2</sup>C-bus is a bi-directional, two-wire, serial data bus for intercommunication between ICs in an equipment. The microcontroller transmits/receives data from the I<sup>2</sup>C-bus transceiver in the TDA4680 over the serial data line SDA (pin 27) synchronized by the serial clock line SCL (pin 28). Both lines are normally connected to a positive voltage supply through pull-up resistors. Data is transferred when the SCL line is LOW. When SCL is HIGH the serial data line SDA must be stable. A HIGH-to-LOW transition of the SDA line when SCL is HIGH is defined as a start bit. A LOW-to-HIGH transition of the SDA line when SCL is HIGH is defined as a stop bit. Each transmission must start with a start bit and end with a stop bit. The bus is busy after a start bit and is only free again after a stop bit has been transmitted.

## I<sup>2</sup>C-bus receiver

(microcontroller write mode)  
 Each transmission to/from the I<sup>2</sup>C-bus transceiver consists of at least three bytes following the start bit. Each byte is acknowledged by an acknowledge bit immediately following each byte. The first byte is the Module Address (MAD) byte, also called slave address byte. This consists of the module address, 1000100<sub>2</sub> for the TDA4680, plus the R/W bit (see Fig.4). When the TDA4680 is a slave receiver (R/W = 0) the module address byte is 1000100<sub>2</sub> (88 Hex). When the TDA4680 is a slave transmitter (R/W = 1) the module address byte is 1000100<sub>1</sub> (89 Hex). The length of a data transmission is unrestricted, but the module address and the correct sub-address must be transmitted before the data byte(s). The order of data transmission is shown in Fig.5 and Fig.6. Without auto-increment (BREN = 0 or 1) the module address (MAD) byte is followed by a Sub-Address (SAD) byte and one data byte only (Fig.5).

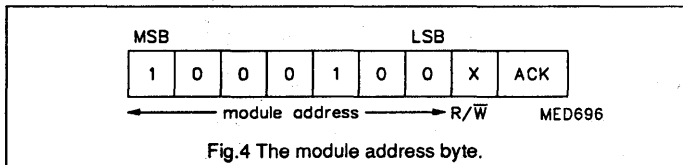

Fig.4 The module address byte.

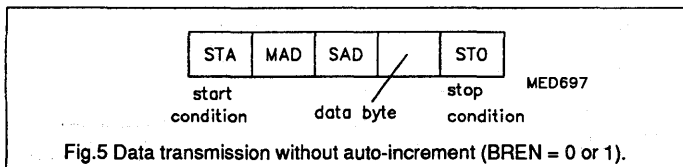

Fig.5 Data transmission without auto-increment (BREN = 0 or 1).

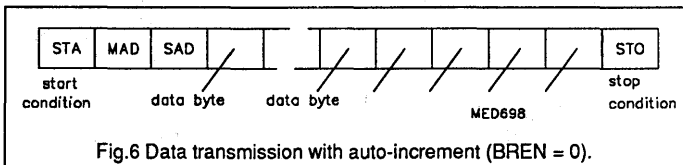

Fig.6 Data transmission with auto-increment (BREN = 0).

## Video processor with automatic cut-off and white level control

TDA4680

### Auto-increment

The auto-increment format enables quick slave receiver initialization by one transmission, when the I<sup>2</sup>C-bus control bit BREN = 0 (see control register bits of Table 1). If BREN = 1 auto-increment is not possible. If the auto-increment format is selected, the MAD byte is followed by an SAD byte and by the data bytes of consecutive sub-addresses (Fig.6).

All sub-addresses from 00 to 0F are automatically incremented, the sub-address counter wraps round from 0F to 00. Reserved sub-addresses 0B, 0E and 0F are treated as legal but have no effect. Sub-addresses outside the range 00 and 0F are not acknowledged by the device and neither auto-increment nor any other internal operation takes place (For versions V1 to V5 sub-addresses outside the range 00 and 0F are acknowledged but neither auto-increment nor any other internal operation takes place). Sub-addresses are stored in the TDA4680 to address the following parameters and functions, see Table 1:

- brightness adjust
- saturation adjust
- contrast adjust
- hue control voltage
- RGB gain adjust
- RGB reference voltage levels
- peak drive limiting adjust
- control register functions.

The data bytes (D7-D0 of Table 1) provide the data of the parameters and functions for video processing.

### Control register 1

VBW<sub>x</sub> (Vertical Blanking Window):

- x = 0, 1 or 2. VBW<sub>x</sub> selects the vertical blanking interval and positions the measurement lines for cut-off and white level control.

The actual lines in the vertical blanking interval after the start of the V pulses selected as measurement

lines for cut-off and white level control are shown in Table 2.

The standards marked with (\*) are for progressive line scan at double line frequency (2FL), i.e. approximately 31 kHz.

NMEN (NTSC - Matrix ENable):

- 0 = PAL/SECAM matrix
- 1 = NTSC matrix.

WPEN (White Pulse ENable):

- 0 = white measuring pulse disabled
- 1 = white measuring pulse enabled.

BREN (Buffer Register ENable):

- 0 = new data is executed as soon as it is received
- 1 = data is stored in buffer registers and is transferred to the data registers during the next vertical blanking interval.

The I<sup>2</sup>C-bus transceiver does not accept any new data until this data is transferred into the data registers.

DELOF (DElAY OFf) delays the leading edge of clamping pulses:

- 0 = delay enabled
- 1 = delay disabled.

SC5 (SandCastle 5 V):

- 0 = 3-level sandcastle pulse
- 1 = 2-level (5 V) sandcastle pulse.

### Control register 2

FSON2 - Fast Switch 2 ON

FSDIS2 - Fast Switch 2 DISable

FSON1 - Fast Switch 1 ON

FSDIS1 - Fast Switch 1 DISable

The RGB input signals are selected by FSON2 and FSON1 or FSW<sub>2</sub> and FSW<sub>1</sub>:

- FSON2 has priority over FSON1;
- FSW<sub>2</sub> has priority over FSW<sub>1</sub>;
- FSDIS1 and FSDIS2 disable FSW<sub>1</sub> and FSW<sub>2</sub> (see Table 3).

BCOF - Black level Control Off:

- 0 = automatic cut-off control enabled
- 1 = automatic cut-off control disabled; RGB outputs are clamped to fixed DC levels.

FSBL - Full Screen Black Level:

- 0 = normal mode
- 1 = full screen black level (cut-off measurement level during full field).

FSWL - Full Screen White Level:

- 0 = normal mode
- 1 = full screen white level (white measurement level during full field).

SATOF - SATuration control Off:

- 0 = saturation control enabled
- 1 = saturation control disabled, nominal saturation enabled.

### I<sup>2</sup>C-bus transmitter

(microcontroller read mode)

As an I<sup>2</sup>C-bus transmitter, R/W = 1, the TDA4680 sends a data byte from the status register to the microcontroller. The data byte consists of following bits:

PONRES, CB1, CB0, CG1, CG0, CR1, CR0 and 0, where PONRES is the most significant bit.

PONRES (Power ON RESet) monitors the state of TDA4680's supply voltage:

- 0 = normal operation
- 1 = supply voltage has dropped below approximately 6.0 V (usually occurs when the TV receiver is switched on or the supply voltage was interrupted).

When PONRES changes state from a logic LOW to a logic HIGH all data and function bits are set to logic LOW.

### 2-bit white level error signal

(see Table 4).

CB1, CB0 = 2-bit white level of the blue channel.

CG1, CG0 = 2-bit white level of the green channel.

CR1, CR0 = 2-bit white level of the red channel.

Video processor with automatic cut-off  
and white level control

TDA4680

**Table 1** Sub-address (SAD) and data bytes.

FUNCTION	SAD (HEX)	DATA BYTE							LSB 0
		MSB 7	6	5	4	3	2	1	
Brightness	00	0	0	A05	A04	A03	A02	A01	A00
Saturation	01	0	0	A15	A14	A13	A12	A11	A10
Contrast	02	0	0	A25	A24	A23	A22	A21	A20
Hue control voltage	03	0	0	A35	A34	A33	A32	A31	A30
Red gain	04	0	0	A45	A44	A43	A42	A41	A40
Green gain	05	0	0	A55	A54	A53	A52	A51	A50
Blue gain	06	0	0	A65	A64	A63	A62	A61	A60
Red level reference	07	0	0	A75	A74	A73	A72	A71	A70
Green level reference	08	0	0	A85	A84	A83	A82	A81	A80
Blue level reference	09	0	0	A95	A94	A93	A92	A91	A90
Peak drive limit	0A	0	0	AA5	AA4	AA3	AA2	AA1	AA0
Reserved	0B	x	x	x	x	x	x	x	x
Control register 1	0C	SC5	DELOF	BREN	WPEN	NMEN	VBW2	VBW1	VBW0
Control register 2	0D	SATOF	FSWL	FSBL	BCOF	FSDIS2	FSON2	FSDIS1	FSON1
Reserved	0E	x	x	x	x	x	x	x	x
Reserved	0F	x	x	x	x	x	x	x	x

**Table 2** Cut-off and white level measurement lines.

VBW2	VBW1	VBW0	R	G	B	WHITE	STANDARD
0	0	0	19	20	21	22	PAL/SECAM
0	0	1	16	17	18	19	NTSC/PAL M
0	1	0	22	23	24	25	PAL/SECAM (EB)
1	0	0	38, 39	40, 41	42, 43	44, 45	PAL*/SECAM*
1	0	1	32, 33	34, 35	36, 37	38, 39	NTSC*/PAL M*
1	1	0	44, 45	46, 47	48, 49	50, 51	PAL*/SECAM* (EB)

**Notes to Table 2**

1. The line numbers given are those of the horizontal pulse counts after the start of the vertical component of the sandcastle pulse.
2. \* line frequency of approximately 31 kHz.
3. (EB) is extended blanking.

Video processor with automatic cut-off  
and white level control

TDA4680

**Table 3** Signal input selection by the fast source switches.

<b>I<sup>2</sup>C-BUS CONTROL BITS</b>				<b>ANALOG SWITCH SIGNALS</b>		<b>INPUT SELECTED</b>		
FSON2	FSDIS2	FSON1	FSDIS1	FSW <sub>2</sub> (pin 1)	FSW <sub>1</sub> (pin 13)	RGB <sub>2</sub>	RGB <sub>1</sub>	Y/CD
L	L	L	L	L	L			ON
				L	H		ON	
				H	X	ON		
L	L	L	H	L	X	ON		ON
				H	X			
L	L	H	X	L	X	ON	ON	
				H	X			
L	H	L	L	X	L			ON
				X	H		ON	
L	H	L	H	X	X			ON
				X	X		ON	
L	H	H	X	X	X			
				X	X	ON		

**Note to Table 3**

Where L is a logic LOW (< 0.4 V), H is a logic HIGH (> 0.9 V), X is 'don't care', and ON is the selected input signal.

**Table 4** 2-bit white level error signals, CX1 and CX0.

CX1	CX0	INTERPRETATION
0	0	RAR (Reset-After-Read): no new measurements since last read
1	0	actual (measured) white level less than the tolerance range
1	1	actual (measured) white level within the tolerance range
0	1	actual (measured) white level greater than the tolerance range

**LIMITING VALUES**

In accordance with the Absolute Maximum Rating System (IEC134).

SYMBOL	PARAMETER	MIN.	MAX.	UNIT
V <sub>P</sub>	supply voltage (pin 5)	–	8.8	V
V <sub>I</sub>	input voltage (pins 1 to 8, 10 to 13, 16, 21, 23 and 25)	–0.1	V <sub>P</sub>	V
	input voltage (pins 14, 15, 18 and 19)	–0.7	V <sub>P</sub> + 0.7	V
	input voltage (pins 27 and 28)	–0.1	8.8	V
I <sub>AV</sub>	average current (pins 20, 22 and 24)	4	–10	mA
I <sub>M</sub>	peak current (pins 20, 22 and 24)	4	–20	mA
I <sub>18</sub>	input current	0	2	mA
I <sub>26</sub>	output current	0.5	–8	mA
T <sub>stg</sub>	storage temperature	–20	+150	°C
T <sub>amb</sub>	operating ambient temperature	0	+70	°C
P <sub>tot</sub>	total power dissipation			
	SOT117	–	1.2	W
	SOT261CG	–	1.0	W

# Video processor with automatic cut-off and white level control

TDA4680

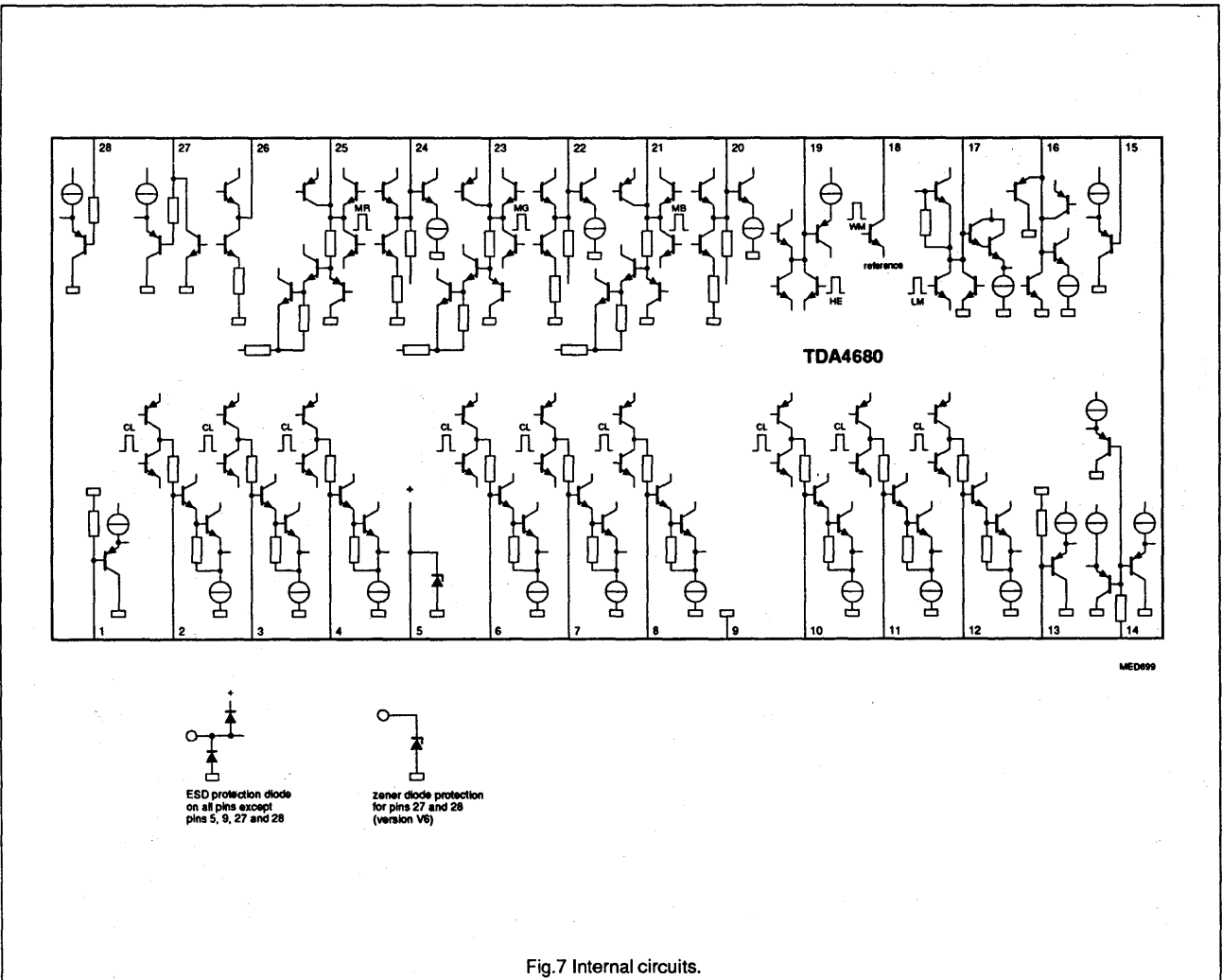

Fig.7 Internal circuits.



Video processor with automatic cut-off  
and white level control

TDA4680

**CHARACTERISTICS**All voltages are measured in test circuit of Fig.8 with respect to GND (pin 9);  $V_P = 8.0\text{ V}$ ;  $T_{amb} = +25\text{ }^\circ\text{C}$ :

- at nominal signal amplitudes (black-to-white) at output pins 24, 22 and 20,
- at nominal settings of brightness, contrast, saturation and white level control,
- without beam current or peak drive limiting; unless otherwise specified.

SYMBOL	PARAMETER	CONDITIONS	MIN.	TYP.	MAX.	UNIT
$V_P$	supply voltage (pin 5)		7.2	8.0	8.8	V
$I_P$	supply current (pin 5)		-	85	110	mA
<b>Colour difference inputs</b>						
$V_{6(p-p)}$	-(B-Y) input (peak-to-peak value)	notes 1 and 2	-	1.33	-	V
$V_{7(p-p)}$	-(R-Y) input (peak-to-peak value)	notes 1 and 2	-	1.05	-	V
$V_{6,7}$	internal DC bias voltage	at black level clamping	-	3.1	-	V
$I_{6,7}$	input current	during line scan	-	-	$\pm 0.1$	$\mu\text{A}$
		at black level clamping	$\pm 100$	-	-	$\mu\text{A}$
$R_{6,7}$	input resistance		10	-	-	M $\Omega$
<b>Luminance/sync (VBS)</b>						
$V_{i(p-p)}$	luminance input at pin 8 (peak-to-peak value)	note 2	-	0.45	-	V
$V_8$	internal DC bias voltage	at black level clamping	-	3.1	-	V
$I_8$	input current	during line scan	-	-	$\pm 0.1$	$\mu\text{A}$
		at black level clamping	$\pm 100$	-	-	$\mu\text{A}$
$R_8$	input resistance		10	-	-	M $\Omega$
<b>R<sub>1</sub>, G<sub>1</sub> and B<sub>1</sub> Inputs</b>						
$V_{i(p-p)}$	black-to-white input signals at pins 10, 11 and 12 (peak-to-peak value)	note 2	-	0.7	-	V
$V_{10/11/12}$	internal DC bias voltage	at black level clamping	-	5.3	-	V
$I_{10/11/12}$	input current	during line scan	-	-	$\pm 0.1$	$\mu\text{A}$
		at black level clamping	$\pm 100$	-	-	$\mu\text{A}$
$R_{10/11/12}$	input resistance		10	-	-	M $\Omega$
<b>R<sub>2</sub>, G<sub>2</sub> and B<sub>2</sub> Inputs</b>						
$V_{i(p-p)}$	black-to-white input signals at pins 2, 3 and 4 (peak-to-peak value)	note 2	-	0.7	-	V
$V_{2/3/4}$	internal DC bias voltage	at black level clamping	-	5.3	-	V
$I_{2/3/4}$	input current	during line scan	-	-	$\pm 0.1$	$\mu\text{A}$
		at black level clamping	$\pm 100$	-	-	$\mu\text{A}$
$R_{2/3/4}$	input resistance		10	-	-	M $\Omega$
<b>PAL/SECAM and NTSC matrix (notes 3 and 4)</b>						
	PAL/SECAM matrix	control bit NMEN = 0				
	NTSC matrix	control bit NMEN = 1				
<b>Fast signal switch FSW<sub>1</sub> to select Y, CD or R<sub>1</sub>, G<sub>1</sub>, B<sub>1</sub> inputs</b> (control bits: see Table 3)						
$V_{13}$	voltage to select Y and CD		-	-	0.4	V
	voltage range to select R <sub>1</sub> , G <sub>1</sub> , B <sub>1</sub>		0.9	-	5.0	V
$R_{13}$	internal resistance to ground		-	4.0	-	k $\Omega$
$\Delta t$	difference between transit times for signal switching and signal insertion		-	-	10	ns

Video processor with automatic cut-off  
and white level control

TDA4680

SYMBOL	PARAMETER	CONDITIONS	MIN.	TYP.	MAX.	UNIT
<b>Fast signal switch FSW<sub>2</sub> to select Y, CD / R<sub>1</sub>, G<sub>1</sub>, B<sub>1</sub> or R<sub>2</sub>, G<sub>2</sub>, B<sub>2</sub> inputs</b> (control bits: see Table 3)						
V <sub>1</sub>	voltage to select Y, CD/R <sub>1</sub> , G <sub>1</sub> , B <sub>1</sub>		–	–	0.4	V
	voltage range to select R <sub>2</sub> , G <sub>2</sub> , B <sub>2</sub>		0.9	–	5.0	V
R <sub>1</sub>	internal resistance to ground		–	4.0	–	kΩ
Δt	difference between transit times for signal switching and signal insertion		–	–	10	ns
<b>Saturation adjust</b> acts on internal RGB signals under I <sup>2</sup> C-bus control, sub-address 01 <sub>Hex</sub> (bit resolution 1.5% of maximum saturation); data byte 3F <sub>Hex</sub> for maximum saturation data byte 23 <sub>Hex</sub> for nominal saturation data byte 00 <sub>Hex</sub> for minimum saturation						
d <sub>s</sub>	saturation below maximum	at 23 <sub>Hex</sub>	–	5	–	dB
		at 00 <sub>Hex</sub> ; f = 100 kHz	–	50	–	dB
<b>Contrast adjust</b> acts on internal RGB signals under I <sup>2</sup> C-bus control, sub-address 02 <sub>Hex</sub> (bit resolution 1.5% of maximum contrast); data byte 3F <sub>Hex</sub> for maximum contrast data byte 2C <sub>Hex</sub> for nominal contrast data byte 00 <sub>Hex</sub> for minimum contrast						
d <sub>c</sub>	contrast below maximum	at 2C <sub>Hex</sub>	–	3	–	dB
		at 00 <sub>Hex</sub>	–	22	–	dB
<b>Brightness adjust</b> acts on internal RGB signals under I <sup>2</sup> C-bus control, sub-address 00 <sub>Hex</sub> (bit resolution 1.5% of brightness range); data byte 3F <sub>Hex</sub> for maximum brightness data byte 27 <sub>Hex</sub> for nominal brightness data byte 00 <sub>Hex</sub> for minimum brightness						
d <sub>br</sub>	black level shift of nominal signal amplitude referred to cut-off measurement level	at 3F <sub>Hex</sub>	–	30	–	%
		at 00 <sub>Hex</sub>	–	–50	–	%
<b>White potentiometers, under I<sup>2</sup>C-bus control,</b> sub-addresses 04 <sub>Hex</sub> (red), 05 <sub>Hex</sub> (green) and 06 <sub>Hex</sub> (blue); see note 5. data byte 3F <sub>Hex</sub> for maximum gain data byte 22 <sub>Hex</sub> for nominal gain data byte 00 <sub>Hex</sub> for minimum gain						
ΔG <sub>v</sub>	relative to nominal gain: increase of gain decrease of gain	at 3F <sub>Hex</sub>	–	60	–	%
		at 00 <sub>Hex</sub>	–	60	–	%

Video processor with automatic cut-off  
and white level control

TDA4680

SYMBOL	PARAMETER	CONDITIONS	MIN.	TYP.	MAX.	UNIT
<b>RGB outputs pins 24, 22 and 20</b> (positive output signals and no peak drive limitation; sub-address $0A_{Hex} = 3F_{Hex}$ ); see note 6.						
$V_{o(b-w)}$	nominal output signals (black-to-white value)		–	2	–	V
	maximum output signals (black-to-white value)		3.2	–	–	V
$\Delta V_o$	spread between RGB output signals		–	–	10	%
$V_o$	minimum output voltages		–	–	0.8	V
	maximum output voltages		6.8	–	–	V
$V_{24,22,20}$	voltage of cut-off measurement line	output clamping (BCOF = 1)	2.3	2.5	2.7	V
$I_{int}$	internal current sources		–	5.0	–	mA
$R_o$	output resistance		–	65	110	$\Omega$
<b>Frequency response</b>						
d	frequency response of Y path (from pin 8 to pins 24, 22, 20)	$f = 10$ MHz	–	–	3	dB
	frequency response of CD path (from pins 7 to 24 and 6 to 20)	$f = 8$ MHz	–	–	3	dB
	frequency response of RGB <sub>1</sub> path (from pins 10 to 24, 11 to 22 and 12 to 20)	$f = 10$ MHz	–	–	3	dB
	frequency response of RGB <sub>2</sub> path (from pins 2 to 24, 3 to 22 and 4 to 20)	$f = 10$ MHz	–	–	3	dB
<b>Sandcastle pulse detector (control bit SC5 = 0)</b> three level; notes 7 and 8						
$V_{14}$	required voltage range for H and V blanking pulses for H pulses (line count) for burst key pulses		2.0	2.5	3.0	V
			4.0	4.5	5.0	V
			6.3	–	$V_P + 0.7$	V
<b>Sandcastle pulse detector (control bit SC5 = 1)</b> two level; note 7						
$V_{14}$	required voltage range for H and V blanking pulses for burst key pulses		2.0	2.5	3.0	V
			4.0	4.5	$V_P + 0.7$	V
<b>Sandcastle pulse detector</b>						
$I_{14}$	input current	$V_{14} = 0$ V	–	–	100	$\mu$ A
$t_d$	leading edge delay of the clamping pulse	control bit DELOF = 0	–	1.5	–	$\mu$ s
		control bit DELOF = 1	–	0	–	$\mu$ s
$t_{BK}$	required burst key pulse time	control bit DELOF = 0; normally used with $t_L$	3	–	–	$\mu$ s
		control bit DELOF = 1; normally used with $2t_L$	1.5	–	–	$\mu$ s
$n_{pulse}$	required horizontal or burst key pulses during vertical blanking interval	e.g. at interlace scan (VBW2 = 0)	4	–	29	
		e.g. at progressive line scan (VBW2 = 1)	8	–	57	

Video processor with automatic cut-off  
and white level control

TDA4680

SYMBOL	PARAMETER	CONDITIONS	MIN.	TYP.	MAX.	UNIT
<b>Average beam current limiting (note 9)</b>						
$V_{c(15)}$	contrast reduction starting voltage		–	4.0	–	V
$\Delta V_{c(15)}$	voltage difference for full contrast reduction		–	–2.0	–	V
$V_{br(15)}$	brightness reduction starting voltage		–	2.5	–	V
$\Delta V_{br(15)}$	voltage difference for full brightness reduction		–	–1.6	–	V
<b>Peak drive limiting voltage (note 10)</b> internal peak drive limiting level ( $V_{pd1}$ ) acts on RGB outputs under I <sup>2</sup> C-bus control, sub-address 0A <sub>Hex</sub>						
$V_{20/22/24}$	level for minimum RGB outputs	at byte 00 <sub>Hex</sub>	–	–	3.0	V
	level for maximum RGB outputs	at byte 3F <sub>Hex</sub>	6.5	–	–	V
$I_{16}$	charge current		–	–1	–	$\mu$ A
	discharge current	during peak white	–	5	–	mA
$V_{16}$	internal voltage limitation		4.5	–	–	V
$V_{c(16)}$	contrast reduction starting voltage		–	4.0	–	V
$\Delta V_{c(16)}$	voltage difference for full contrast reduction		–	–2.0	–	V
$V_{br(16)}$	brightness reduction starting voltage		–	2.5	–	V
$\Delta V_{br(16)}$	voltage difference for full brightness reduction		–	–1.6	–	V
<b>Automatic cut-off and white level control (notes 11, 12 and 13)</b> see Fig.10						
$V_{19}$	permissible voltage (also during scanning period)		–	–	$V_p - 1.4$	V
$I_{19}$	output current		–	–	–140	$\mu$ A
	input current		150	–	–	$\mu$ A
	additional input current	during monitor pulse	–	0.5	–	mA
$V_{24,22,20}$	monitor pulse amplitude (under I <sup>2</sup> C-bus control, sub-address 0A <sub>Hex</sub> )	switch-on delay 1	–	$V_{pd1} - 0.7$	–	V
$V_{19}$	voltage threshold for picture tube cathode warm-up	switch-on delay 1	–	5.0	–	V
	internally controlled voltage ( $V_{REF}$ )	during leakage measurement period	–	3.0	–	V
data byte 07 <sub>Hex</sub> for red reference level data byte 08 <sub>Hex</sub> for green reference level data byte 09 <sub>Hex</sub> for blue reference level						
$\Delta V_{19}$	difference between $V_{MEAS}$ (cut-off or white level measurement voltage) and $V_{REF}$	3F <sub>Hex</sub> (maximum $V_{MEAS}$ )	1.5	–	–	V
		20 <sub>Hex</sub> (nominal $V_{MEAS}$ )	–	1.0	–	V
		00 <sub>Hex</sub> (minimum $V_{MEAS}$ )	–	–	0.5	V
$I_{18}$	input current	white level measurement	–	–	800	$\mu$ A
$R_{18}$	internal resistance	to $V_{REF}$ ; $I_{18} \leq 800 \mu$ A	–	100	–	$\Omega$
$\Delta V_{19}$	white level register (measured value within tolerance range)	white level measurement	–	250	–	mV

Video processor with automatic cut-off  
and white level control

TDA4680

SYMBOL	PARAMETER	CONDITIONS	MIN.	TYP.	MAX.	UNIT
<b>Cut-off storage</b>						
I <sub>21/23/25</sub>	charge and discharge currents	during cut-off measurement lines	–	±0.3	–	mA
	current	outside measurement	–	–	±0.1	µA
<b>Leakage storage</b>						
I <sub>17</sub>	charge and discharge currents	during leakage measurement period	–	±0.4	–	mA
	current	outside measurement	–	–	±0.1	µA
V <sub>17</sub>	voltage for reset to switch-on below		–	< 3.0	–	V
<b>Hue control (note 14)</b> under I <sup>2</sup> C-bus control, sub-address 03 <sub>Hex</sub> data byte 3F <sub>Hex</sub> for maximum voltage data byte 20 <sub>Hex</sub> for nominal voltage data byte 00 <sub>Hex</sub> for minimum voltage						
V <sub>26</sub>	output voltage	at byte 3F <sub>Hex</sub>	4.8	–	–	V
		at byte 20 <sub>Hex</sub>	–	3.0	–	V
		at byte 00 <sub>Hex</sub>	–	–	1.0	V
I <sub>int</sub>	current of the internal current source at pin 26		500	–	–	µA
<b>I<sup>2</sup>C-bus transceiver clock SCL (pin 28)</b>						
f <sub>SCL</sub>	input frequency range		0	–	100	kHz
V <sub>IL</sub>	LOW level input voltage		–	–	1.5	V
V <sub>IH</sub>	HIGH level input voltage		3.0	–	6	V
I <sub>IL</sub>	LOW level input current		–	–	–10	µA
I <sub>IH</sub>	HIGH level input current		–	–	10	µA
t <sub>d</sub>	pulse delay time LOW		4.7	–	–	µs
	pulse delay time HIGH		4.0	–	–	µs
t <sub>r</sub>	rise time		–	–	1.0	µs
t <sub>f</sub>	fall time		–	–	0.3	µs
<b>I<sup>2</sup>C-bus transceiver data input/output SDA (pin 27)</b>						
V <sub>IL</sub>	LOW level input voltage		–	–	1.5	V
V <sub>IH</sub>	HIGH level input voltage		3.0	–	6	V
I <sub>IL</sub>	LOW level input current		–	–	–10	µA
I <sub>IH</sub>	HIGH level input current		–	–	10	µA
I <sub>OL</sub>	LOW level output current		3.0	–	–	mA
t <sub>r</sub>	rise time		–	–	1.0	µs
t <sub>f</sub>	fall time		–	–	0.3	µs
t <sub>SU;DAT</sub>	data set-up time		0.25	–	–	µs

# Video processor with automatic cut-off and white level control

TDA4680

## Notes to the characteristics

- The values of the  $-(B-Y)$  and  $-(R-Y)$  colour difference input signals are for a 75% colour-bar signal.
- The pins are capacitively coupled to a low ohmic source, with a recommended maximum output impedance of 600  $\Omega$ .
- PAL/SECAM signals are matrixed by the equation:  $V_{G-Y} = -0.51V_{R-Y} - 0.19V_{B-Y}$   
NTSC signals are matrixed by the equations (hue phase shift of  $-5$  degrees):  
 $V_{R-Y}^* = 1.57V_{R-Y} - 0.41V_{B-Y}$ ;  $V_{G-Y}^* = -0.43V_{R-Y} - 0.11V_{B-Y}$ ;  $V_{B-Y}^* = V_{B-Y}$   
In the matrix equations:  $V_{R-Y}$  and  $V_{B-Y}$  are conventional PAL demodulation axes and amplitudes at the output of the NTSC demodulator.  $V_{G-Y}^*$ ,  $V_{R-Y}^*$  and  $V_{B-Y}^*$  are the NTSC-modified colour difference signals; this is equivalent to the following demodulator axes and amplification factors:

	NTSC	PAL
$(B-Y)^*$ demodulator axis	$0^\circ$	$0^\circ$
$(R-Y)^*$ demodulator axis	$115^\circ$	$90^\circ$
$(R-Y)^*$ amplification factor	1.97	1.14
$(B-Y)^*$ amplification factor	2.03	2.03

$$V_{G-Y}^* = -0.27V_{R-Y}^* - 0.22V_{B-Y}^*$$

- The vertical blanking interval is selected via the I<sup>2</sup>C-bus (see Table 2 and Fig.10). Vertical blanking is determined by the vertical component of the sandcastle pulse; this vertical component has priority when it is longer than the vertical blanking interval of the transmission standard.
- The white potentiometers affect the amplitudes of the RGB output signals including the white measurement pulses.
- The RGB outputs at pins 24, 22 and 20 are emitter followers with current sources.
- Sandcastle pulses are compared with internal threshold voltages independent of  $V_P$ . The threshold voltages separate the components of the sandcastle pulse. The particular component is generated when the voltage on pin 14 exceeds the defined internal threshold voltage. The internal threshold voltages (control bit SC5 = 0) are:
  - 1.5 V for horizontal and vertical blanking pulses (H and V blanking pulses),
  - 3.5 V for horizontal pulses,
  - 6.0 V for the burst key pulse.
 The internal threshold voltages, control bit SC5 = 1, are:
  - 1.5 V for horizontal and vertical blanking pulses,
  - 3.5 V for the burst key pulse.
- A sandcastle pulse with a maximum voltage equal to  $(V_P + 0.7 \text{ V})$  is obtained by limiting a 12 V sandcastle pulse.
- Average beam current limiting reduces the contrast, at minimum contrast it reduces the brightness.
- Peak drive limiting reduces the RGB outputs by reducing the contrast, at minimum contrast it reduces the brightness. The maximum RGB outputs are determined via the I<sup>2</sup>C-bus under sub-address 0A<sub>Hex</sub>. When an RGB output exceeds the maximum voltage, peak drive limiting is delayed by one horizontal line.
- The vertical blanking interval is defined by a V pulse which contains 4 (8) or more H pulses; it begins with the start of the V pulse and ends with the end of the white measuring line. If the V pulse is longer than the selected vertical blanking window the blanking period ends with the end of the complete line after the end of the V pulse. The counter cycle time is 31 (63) H pulses. If the V pulse contains more than 29 (57) H pulses, the black level storage capacitors will be discharged while all signals are blanked. During leakage current measurement, the RGB channels are blanked to ultra-black level. During cut-off measurement one channel is set to the measurement pulse level, the other channels are blanked to ultra-black. Since the brightness adjust shifts the colour signal relative to the black level, the brightness adjust is disabled during the vertical blanking interval (see Figs 9 and 10).
- During picture cathode warm-up (first switch-on delay) the RGB outputs (pins 24, 22 and 20) are blanked to the ultra-black level during line scan. During the vertical blanking interval a white-level monitor pulse is fed out on the RGB outputs and the cathode currents are measured. When the voltage threshold on pin 19 is greater than 5.0 V, the monitor pulse is switched off and cut-off and white level control are activated (second switch-on delay). As soon as cut-off control stabilize, RGB output blanking is removed.
- Range of cut-off measurement level at the RGB outputs is 1 to 5 V. The recommended value is 3 V.
- The hue control output at pin 26 is an emitter follower with current source.

# Video processor with automatic cut-off and white level control

TDA4680

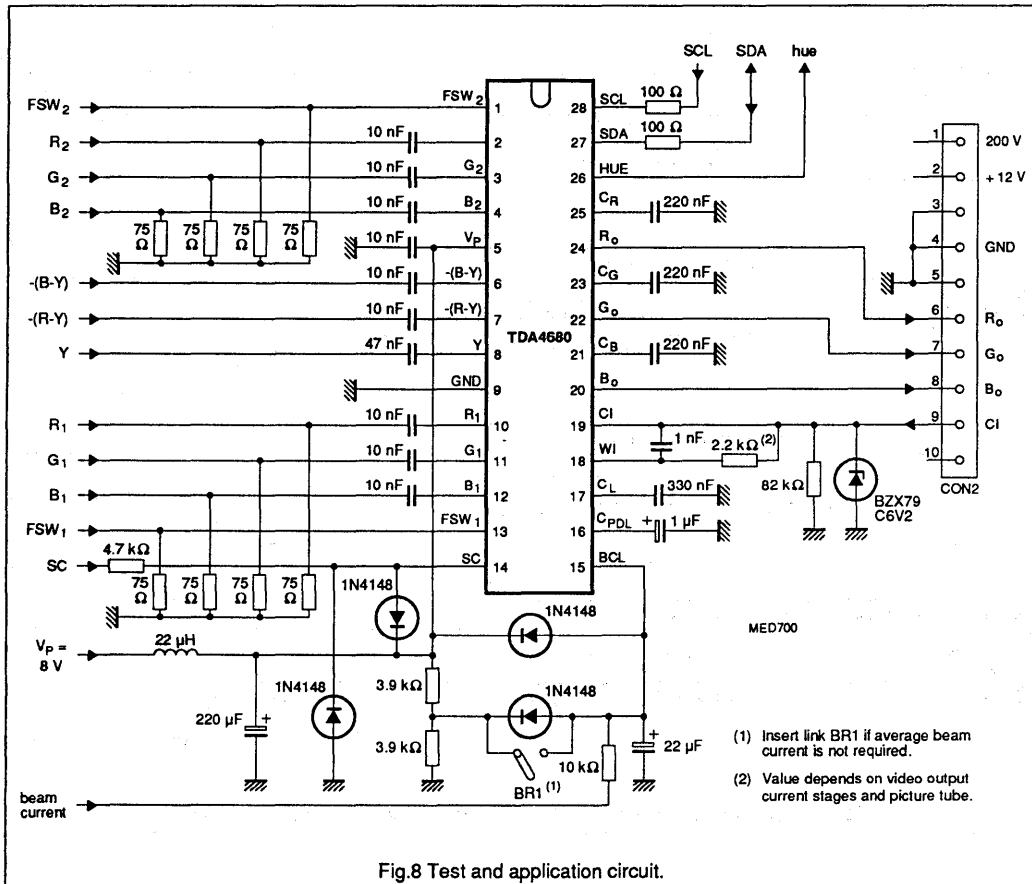

Fig. 8 Test and application circuit.

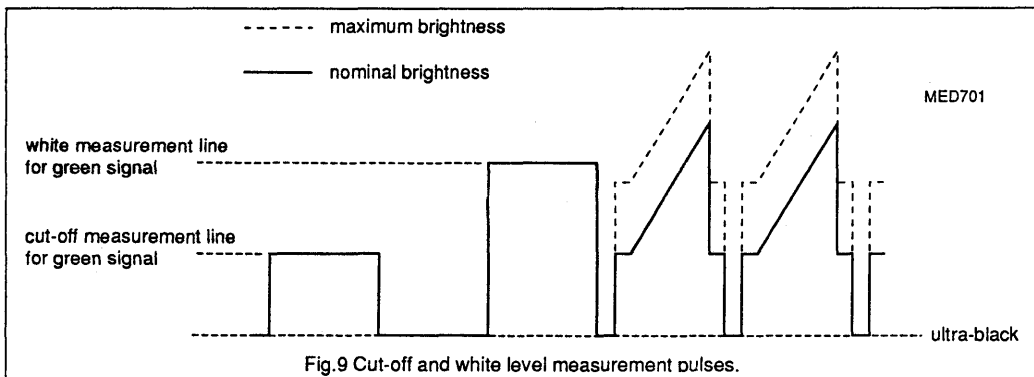

Fig. 9 Cut-off and white level measurement pulses.

# Video processor with automatic cut-off and white level control

TDA4680

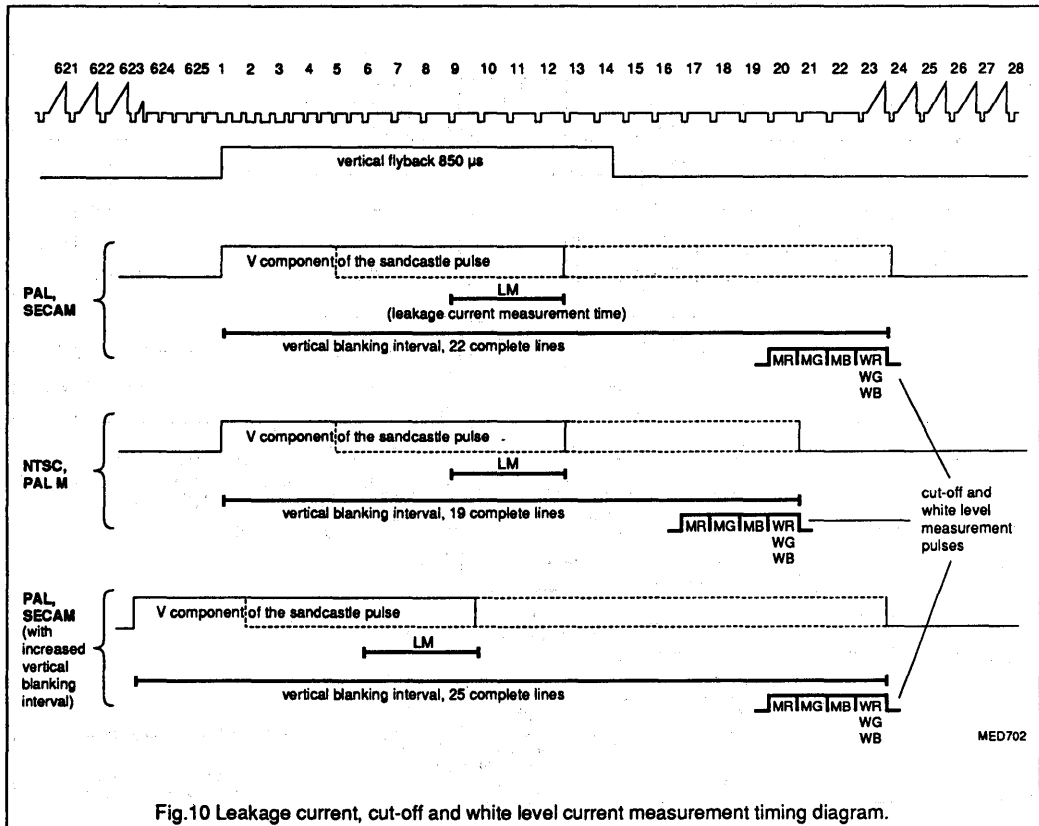

Fig.10 Leakage current, cut-off and white level current measurement timing diagram.



## Video processor with automatic cut-off control

TDA4686

## FEATURES

- Intended for double line frequency application (100/120 Hz)
- Operates from an 8 V DC supply
- Black level clamping of the colour difference, luminance and RGB input signals with coupling-capacitor DC level storage
- Two analog RGB inputs, selected either by fast switch signals or the I<sup>2</sup>C-bus; brightness and contrast control of these RGB inputs
- Saturation, contrast, brightness and white adjustment via I<sup>2</sup>C-bus
- Same RGB output black levels for Y/CD and RGB input signals
- Timing pulse generation from either a 2- or 3-level sandcastle pulse for clamping, vertical synchronization and cut-off timing pulses
- Automatic cut-off control or clamped output selectable via I<sup>2</sup>C-bus
- Automatic cut-off control with picture tube leakage current compensation
- Cut-off measurement pulses after end of the vertical blanking pulse or end of an extra vertical flyback pulse
- Increased RGB signal bandwidths
- Two switch-on delays to prevent discolouration before steady-state operation
- Average beam current and peak drive limiting
- PAL/SECAM or NTSC matrix selection via I<sup>2</sup>C-bus
- Emitter-follower RGB output stages to drive the video output stages
- I<sup>2</sup>C-bus controlled DC output e. g. for hue-adjust of NTSC (multistandard) decoders
- No delay of clamping pulse
- Large luminance, colour difference and RGB bandwidth

## GENERAL DESCRIPTION

The TDA4686 is a monolithic, integrated circuit with a luminance and a colour difference interface for video processing in TV receivers.

(continued)

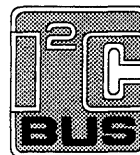

## QUICK REFERENCE DATA

SYMBOL	PARAMETER	MIN.	TYP.	MAX.	UNIT
V <sub>P</sub>	supply voltage (pin 5)	7.2	8.0	8.8	V
I <sub>P</sub>	supply current (pin 5)	–	60	–	mA
V <sub>8(p-p)</sub>	luminance input (peak-to-peak value)	–	0.45	–	V
V <sub>6(p-p)</sub>	–(B–Y) input (peak-to-peak value)	–	1.33	–	V
V <sub>7(p-p)</sub>	–(R–Y) input (peak-to-peak value)	–	1.05	–	V
V <sub>14</sub>	three-level sandcastle pulse				
	H+V	–	2.5	–	V
	H	–	4.5	–	V
	BK	–	8.0	–	V
	two-level sandcastle pulse				
	H+V	–	2.5	–	V
	BK	–	4.5	–	V
V <sub>i</sub>	RGB input signals at pins 2, 3, 4, 10, 11 and 12 (black-to-white value)	–	0.7	–	V
V <sub>o(p-p)</sub>	RGB outputs at pins 24, 22 and 20 (peak-to-peak value)	–	2.0	–	V
T <sub>amb</sub>	operating ambient temperature	0	–	+70	°C

## ORDERING INFORMATION

EXTENDED TYPE NUMBER	PACKAGE			
	PINS	PIN POSITION	MATERIAL	CODE
TDA4686	28	DIL	plastic	SOT117
TDA4686WP	28	PLCC	plastic	SOT261CG

Video processor with automatic cut-off control

TDA4686

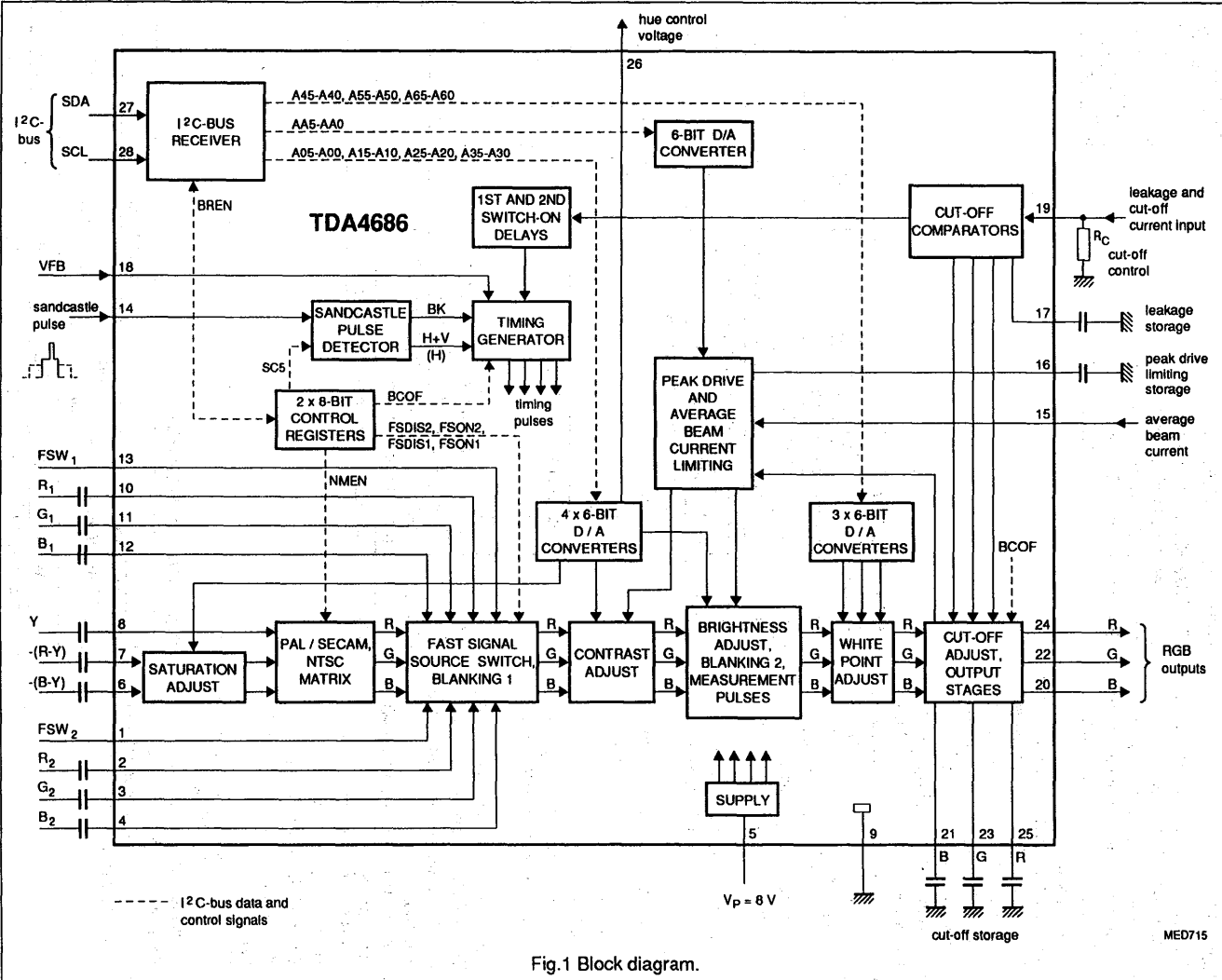

Fig.1 Block diagram.

MED715

Video processor with automatic cut-off control

TDA4686

PINNING

SYMBOL	PIN	DESCRIPTION
FSW <sub>2</sub>	1	fast switch 2 input
R <sub>2</sub>	2	red input 2
G <sub>2</sub>	3	green input 2
B <sub>2</sub>	4	blue input 2
V <sub>P</sub>	5	supply voltage
-(B-Y)	6	colour difference input -(B-Y)
-(R-Y)	7	colour difference input -(R-Y)
Y	8	luminance input
GND	9	ground
R <sub>1</sub>	10	red input 1
G <sub>1</sub>	11	green input 1
B <sub>1</sub>	12	blue input 1
FSW <sub>1</sub>	13	fast switch 1 input
SC	14	sandcastle pulse input

SYMBOL	PIN	DESCRIPTION
BCL	15	average beam current limiting input
CPDL	16	storage capacitor for peak drive limiting
C <sub>L</sub>	17	storage capacitor for leakage current
V <sub>FB</sub>	18	vertical flyback pulse input
CI	19	cut-off measurement input
B <sub>O</sub>	20	blue output
C <sub>B</sub>	21	blue cut-off storage capacitor
G <sub>O</sub>	22	green output
C <sub>G</sub>	23	green cut-off storage capacitor
R <sub>O</sub>	24	red output
C <sub>R</sub>	25	red cut-off storage capacitor
HUE	26	hue control output
SDA	27	I <sup>2</sup> C-bus serial data input / acknowledge output
SCL	28	I <sup>2</sup> C-bus serial clock input

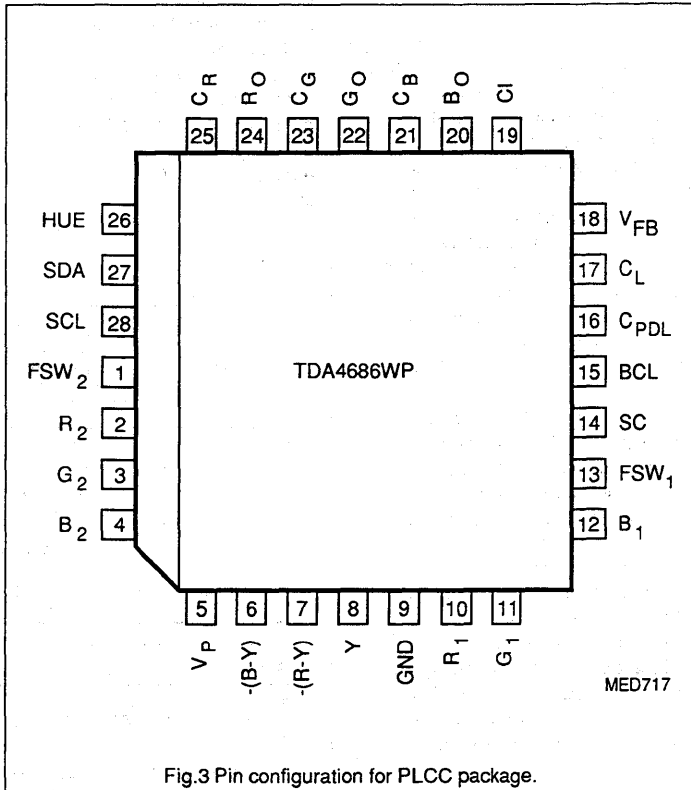
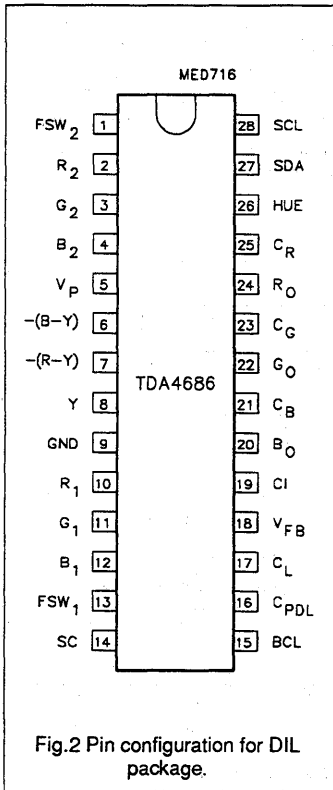



## Video processor with automatic cut-off control

TDA4686

**I<sup>2</sup>C-bus receiver**

(microcontroller write mode)

Each transmission to the I<sup>2</sup>C-bus receiver consists of at least three bytes following the start bit. Each byte is acknowledged by an acknowledge bit immediately following each byte. The first byte is the Module Address (MAD) byte, also called slave address byte. This includes the module address, 1000100<sub>2</sub> for the TDA4686. The TDA4686 is a slave receiver (R/W = 0), therefore the module address byte is 1000100<sub>2</sub> (88 Hex), see Fig.4.

The length of a data transmission is unrestricted, but the module address and the correct sub-address must be transmitted before the data byte(s). The order of data transmission is shown in Fig.5 and Fig.6. Without auto-increment (BREN = 0 or 1) the Module Address (MAD) byte is followed by a Sub-Address (SAD) byte and one data byte only (Fig.5).

**Auto-increment**

The auto-increment format enables quick slave receiver initialization by one transmission, when the I<sup>2</sup>C-bus control bit BREN = 0 (see control register bits of Table 1). If BREN = 1 auto-increment is not possible. If the auto-increment format is selected, the MAD byte is followed by an SAD byte and by the data bytes of consecutive sub-addresses (Fig.6).

All sub-addresses from 00 to 0F are automatically incremented, the sub-address counter wraps round from 0F to 00. Reserved sub-addresses 07, 08, 09, 0B, 0E and 0F are treated as legal but have no effect. Sub-addresses outside the range 00 and 0F are not acknowledged by the device. The sub-addresses are stored in the TDA4686 to address the following parameters and functions, see Table 1:

- brightness adjust
- saturation adjust
- contrast adjust
- hue control voltage
- RGB gain adjust
- peak drive limiting adjust
- control register functions.

The data bytes (D7-D0 of Table 1) provide the data of the parameters and functions for video processing.

**Control register 1****NMEN (NTSC-Matrix ENable):**

- 0 = PAL/SECAM matrix
- 1 = NTSC matrix.

**BREN (Buffer Register ENable):**

- 0 = new data is executed as soon as it is received
- 1 = data is stored in buffer registers and is transferred to the data registers during the next vertical blanking interval. The I<sup>2</sup>C-bus receiver does not accept any new data until this data is transferred into the data registers.

**SC5 (SandCastle 5 V):**

- 0 = 3-level sandcastle pulse
- 1 = 2-level (5 V) sandcastle pulse.

**Control register 2****FSON2 - Fast Switch 2 ON****FSDIS2 - Fast Switch 2 DISable****FSON1 - Fast Switch 1 ON****FSDIS1 - Fast Switch 1 DISable**

The RGB input signals are selected by FSON2 and FSON1 or FSW<sub>2</sub> and FSW<sub>1</sub>:

- FSON2 has priority over FSON1;
- FSW<sub>2</sub> has priority over FSW<sub>1</sub>;
- FSDIS1 and FSDIS2 disable FSW<sub>1</sub> and FSW<sub>2</sub> (see Table 2).

**BCOF - Black level Control OFF:**

- 0 = automatic cut-off control enabled
- 1 = automatic cut-off control disabled; RGB outputs are clamped to fixed DC levels.

When the supply voltage has dropped below approximately 6.0 V (usually occurs when the TV receiver is switched on or the supply voltage is interrupted) all data and function bits are set to 01<sub>Hex</sub>.

## Video processor with automatic cut-off control

TDA4686

Table 1 Sub-address (SAD) and data bytes.

FUNCTION	SAD (HEX)	MSB			DATA BYTE					LSB
		7	6	5	4	3	2	1	0	
Brightness	00	0	0	A05	A04	A03	A02	A01	A00	
Saturation	01	0	0	A15	A14	A13	A12	A11	A10	
Contrast	02	0	0	A25	A24	A23	A22	A21	A20	
Hue control voltage	03	0	0	A35	A34	A33	A32	A31	A30	
Red gain	04	0	0	A45	A44	A43	A42	A41	A40	
Green gain	05	0	0	A55	A54	A53	A52	A51	A50	
Blue gain	06	0	0	A65	A64	A63	A62	A61	A60	
Reserved	07	0	0	x	x	x	x	x	x	
Reserved	08	0	0	x	x	x	x	x	x	
Reserved	09	0	0	x	x	x	x	x	x	
Peak drive limit	0A	0	0	AA5	AA4	AA3	AA2	AA1	AA0	
Reserved	0B	x	x	x	x	x	x	x	x	
Control register 1	0C	SC5	x	BREN	x	NMEN	x	x	x	
Control register 2	0D	x	x	x	BCOF	FSDIS2	FSON2	FSDIS1	FSON1	
Reserved	0E	x	x	x	x	x	x	x	x	
Reserved	0F	x	x	x	x	x	x	x	x	

## Note to Table 1

X is 'don't care', but for software compatibility with other or future video ICs it is recommended to set all 'X' to '0'.

Table 2 Signal input selection by the fast source switches.

I <sup>2</sup> C-BUS CONTROL BITS				ANALOG SWITCH SIGNALS		INPUT SELECTED		
FSON2	FSDIS2	FSON1	FSDIS1	FSW <sub>2</sub> (pin 1)	FSW <sub>1</sub> (pin 13)	RGB <sub>2</sub>	RGB <sub>1</sub>	Y/CD
L	L	L	L	L	L		ON	ON
				L	H			
				H	X	ON		
L	L	L	H	L	X	ON		ON
				H	X			
L	L	H	X	L	X	ON	ON	
				H	X			
L	H	L	L	X	L			ON
				X	H		ON	
L	H	L	H	X	X			ON
				X	X		ON	
L	H	H	X	X	X		ON	
H	X	X	X	X	X	ON		

## Note to Table 2

Where L is a logic LOW (< 0.4 V), H is a logic HIGH (> 0.9 V), X is 'don't care', and ON is the selected input signal.

## Video processor with automatic cut-off control

TDA4686

**LIMITING VALUES**

In accordance with the Absolute Maximum Rating System (IEC134).

SYMBOL	PARAMETER	MIN.	MAX.	UNIT
$V_P$	supply voltage (pin 5)	–	8.8	V
$V_I$	input voltage (pins 1 to 8, 10 to 13, 16, 21, 23 and 25)	–0.1	$V_P$	V
	input voltage (pins 15, 18 and 19)	–0.7	$V_P + 0.7$	V
	input voltage (pins 27 and 28)	–0.1	8.8	V
$V_{14}$	sandcastle pulse voltage	–0.7	$V_P + 5.8$	V
$I_{AV}$	average current (pins 20, 22 and 24)	–10	4	mA
$I_M$	peak current (pins 20, 22 and 24)	–20	4	mA
$I_{26}$	output current	–8	0.6	mA
$T_{stg}$	storage temperature	–20	+150	°C
$T_{amb}$	operating ambient temperature	0	+70	°C
$P_{tot}$	total power dissipation			
	SOT117	–	1.2	W
	SOT261CG	–	1.0	W

# Video processor with automatic cut-off control

# TDA4686

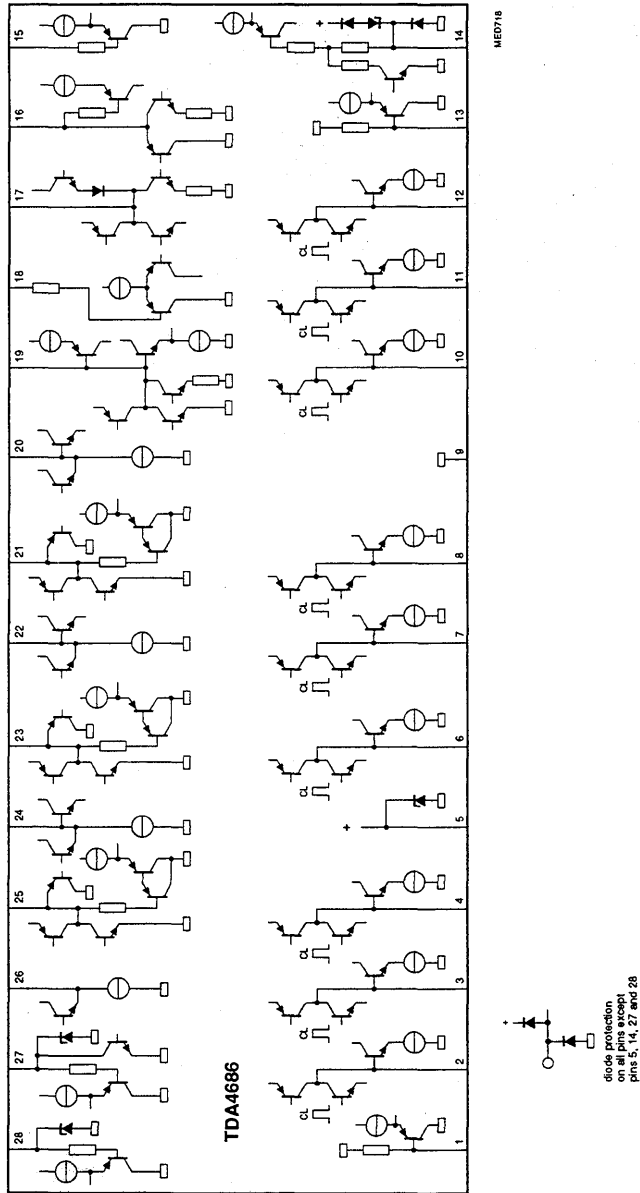

Fig.7 Internal circuits.



## Video processor with automatic cut-off control

TDA4686

**CHARACTERISTICS**

All voltages are measured in test circuit of Fig.8 with respect to GND (pin 9);  $V_P = 8.0\text{ V}$ ;  $T_{\text{amb}} = +25\text{ }^\circ\text{C}$ :

- at nominal signal amplitudes (black-to-white) at output pins 24, 22 and 20,
- at nominal settings of brightness, contrast, saturation and white level control,
- without beam current or peak drive limiting; unless otherwise specified.

SYMBOL	PARAMETER	CONDITIONS	MIN.	TYP.	MAX.	UNIT
$V_P$	supply voltage (pin 5)		7.2	8.0	8.8	V
$I_P$	supply current (pin 5)		-	60	-	mA
<b>Colour difference inputs</b>						
$V_{6(p-p)}$	-(B-Y) input (peak-to-peak value)	notes 1 and 2	-	1.33	-	V
$V_{7(p-p)}$	-(R-Y) input (peak-to-peak value)	notes 1 and 2	-	1.05	-	V
$V_{6,7}$	internal DC bias voltage	at black level clamping	-	4.1	-	V
$I_{6,7}$	input current	during line scan	-	-	$\pm 0.1$	$\mu\text{A}$
		at black level clamping	$\pm 100$	-	-	$\mu\text{A}$
$R_{6,7}$	input resistance		10	-	-	$\text{M}\Omega$
<b>Luminance/sync (VBS)</b>						
$V_{i(p-p)}$	luminance input at pin 8 (peak-to-peak value)	note 2	-	0.45	-	V
$V_8$	internal DC bias voltage	at black level clamping	-	4.1	-	V
$I_8$	input current	during line scan	-	-	$\pm 0.1$	$\mu\text{A}$
		at black level clamping	$\pm 100$	-	-	$\mu\text{A}$
$R_8$	input resistance		10	-	-	$\text{M}\Omega$
<b>R<sub>1</sub>, G<sub>1</sub> and B<sub>1</sub> inputs</b>						
$V_{i(p-p)}$	black-to-white input signals at pins 10, 11 and 12 (peak-to-peak value)	note 2	-	0.7	-	V
$V_{10/11/12}$	internal DC bias voltage	at black level clamping	-	5.7	-	V
$I_{10/11/12}$	input current	during line scan	-	-	$\pm 0.1$	$\mu\text{A}$
		at black level clamping	$\pm 100$	-	-	$\mu\text{A}$
$R_{10/11/12}$	input resistance		10	-	-	$\text{M}\Omega$
<b>R<sub>2</sub>, G<sub>2</sub> and B<sub>2</sub> inputs</b>						
$V_{i(p-p)}$	black-to-white input signals at pins 2, 3 and 4 (peak-to-peak value)	note 2	-	0.7	-	V
$V_{2/3/4}$	internal DC bias voltage	at black level clamping	-	5.7	-	V
$I_{2/3/4}$	input current	during line scan	-	-	$\pm 0.1$	$\mu\text{A}$
		at black level clamping	$\pm 100$	-	-	$\mu\text{A}$
$R_{2/3/4}$	input resistance		10	-	-	$\text{M}\Omega$
<b>PAL/SECAM and NTSC matrix (note 3)</b>						
	PAL/SECAM matrix	control bit NMEN = 0				
	NTSC matrix	control bit NMEN = 1				
<b>Fast signal switch FSW<sub>1</sub> to select Y, CD or R<sub>1</sub>, G<sub>1</sub>, B<sub>1</sub> inputs</b>						
control bits FSDIS1, FSON1 (see Table 2)						
$V_{13}$	voltage to select Y and CD		-	-	0.4	V
	voltage range to select R <sub>1</sub> , G <sub>1</sub> , B <sub>1</sub>		0.9	-	5.0	V
$R_{13}$	internal resistance to ground		-	4.0	-	$\text{k}\Omega$
$\Delta t$	difference between transit times for signal switching and signal insertion		-	-	10	ns

## Video processor with automatic cut-off control

TDA4686

SYMBOL	PARAMETER	CONDITIONS	MIN.	TYP.	MAX.	UNIT
<b>Fast signal switch FSW<sub>2</sub> to select Y, CD / R<sub>1</sub>, G<sub>1</sub>, B<sub>1</sub> or R<sub>2</sub>, G<sub>2</sub>, B<sub>2</sub> inputs</b> control bits FSDIS2, FSON2 (see Table 2)						
V <sub>1</sub>	voltage to select Y, CD/R <sub>1</sub> , G <sub>1</sub> , B <sub>1</sub>		–	–	0.4	V
	voltage range to select R <sub>2</sub> , G <sub>2</sub> , B <sub>2</sub>		0.9	–	5.0	V
R <sub>1</sub>	internal resistance to ground		–	4.0	–	kΩ
Δt	difference between transit times for signal switching and signal insertion		–	–	10	ns
<b>Saturation adjust</b> acts on –(R–Y) and –(B–Y) signals under I <sup>2</sup> C-bus control, sub-address 01 <sub>Hex</sub> (bit resolution 1.5% of maximum saturation); data byte 3F <sub>Hex</sub> for maximum saturation data byte 23 <sub>Hex</sub> for nominal saturation data byte 00 <sub>Hex</sub> for minimum saturation						
d <sub>s</sub>	saturation below maximum	at 23 <sub>Hex</sub>	–	5	–	dB
		at 00 <sub>Hex</sub> ; f = 100 kHz	–	50	–	dB
<b>Contrast adjust</b> acts on internal RGB signals under I <sup>2</sup> C-bus control, sub-address 02 <sub>Hex</sub> (bit resolution 1.5% of maximum contrast); data byte 3F <sub>Hex</sub> for maximum contrast data byte 22 <sub>Hex</sub> for nominal contrast data byte 00 <sub>Hex</sub> for minimum contrast						
d <sub>c</sub>	contrast below maximum	at 22 <sub>Hex</sub>	–	5	–	dB
		at 00 <sub>Hex</sub>	–	22	–	dB
<b>Brightness adjust</b> acts on internal RGB signals under I <sup>2</sup> C-bus control, sub-address 00 <sub>Hex</sub> (bit resolution 1.5% of maximum brightness); data byte 3F <sub>Hex</sub> for maximum brightness data byte 26 <sub>Hex</sub> for nominal brightness data byte 00 <sub>Hex</sub> for minimum brightness						
d <sub>br</sub>	black level shift of nominal signal amplitude referred to cut-off measurement level	at 3F <sub>Hex</sub>	–	30	–	%
		at 00 <sub>Hex</sub>	–	–50	–	%
<b>White potentiometers, under I<sup>2</sup>C-bus control,</b> sub-addresses 04 <sub>Hex</sub> (red), 05 <sub>Hex</sub> (green) and 06 <sub>Hex</sub> (blue); note 4. data byte 3F <sub>Hex</sub> for maximum gain data byte 19 <sub>Hex</sub> for nominal gain data byte 00 <sub>Hex</sub> for minimum gain						
ΔG <sub>v</sub>	relative to nominal gain: increase of gain decrease of gain	at 3F <sub>Hex</sub>	–	50	–	%
		at 00 <sub>Hex</sub>	–	50	–	%

## Video processor with automatic cut-off control

TDA4686

SYMBOL	PARAMETER	CONDITIONS	MIN.	TYP.	MAX.	UNIT
<b>RGB outputs</b> pins 24, 22 and 20 (positive going output signals; peak drive limiter set = $3F_{Hex}$ ); note 5.						
$V_{O(b-w)}$	nominal output signal amplitudes (black-to-white value)		–	2	–	V
	maximum output signal amplitudes (black-to-white value)		3.0	–	–	V
$\Delta V_o$	spread between RGB output signals		–	–	10	%
$V_o$	minimum output voltages		–	–	0.8	V
	maximum output voltages		6.8	–	–	V
$V_{24,22,20}$	voltage of cut-off measurement line	BCOF = 1 (output clamping)	2.3	2.5	2.7	V
$I_{int}$	internal current sources		–	5.0	–	mA
$R_o$	output resistance		–	20	–	$\Omega$
<b>Frequency response</b> (measured with 10 M $\Omega$ , 30 pF external load)						
d	frequency response of Y path (from pin 8 to pins 24, 22, 20)	f = 14 MHz	–	–	3	dB
	frequency response of CD path (from pins 7 to 24 and 6 to 20)	f = 12 MHz	–	–	3	dB
	frequency response of RGB <sub>1</sub> path (from pins 10 to 24, 11 to 22 and 12 to 20)	f = 22 MHz	–	–	3	dB
	frequency response of RGB <sub>2</sub> path (from pins 2 to 24, 3 to 22 and 4 to 20)	f = 22 MHz	–	–	3	dB
<b>Sandcastle pulse detector</b> (control bit SC5 = 0) three level; notes 6 and 7						
$V_{14}$	required voltage range for H and V blanking pulses		2.0	2.5	3.0	V
	for H pulses (line count)		4.0	4.5	5.0	V
	for burst key pulses (clamping)		7.6	–	$V_p + 5.8$	V
<b>Sandcastle pulse detector</b> (control bit SC5 = 1) two level; notes 6 and 7						
$V_{14}$	required voltage range for H and V blanking pulses		2.0	2.5	3.0	V
	for burst key pulses		4.0	4.5	$V_p + 5.8$	V
<b>Sandcastle pulse detector</b>						
$I_{14}$	output current	$V_{14} = 0$ V	–	–	–100	$\mu$ A
$t_d$	leading edge delay of the clamping pulse		–	0	–	$\mu$ s
<b>VFB</b> (note 7)						
$V_{18}$	vertical flyback pulse	for LOW	–	–	2.5	V
		for HIGH	4.5	–	–	V
	internal voltage	pin 18 open-circuit; note 8	–	5.0	–	V
$I_{18}$	input current		–	–	5	$\mu$ A

## Video processor with automatic cut-off control

TDA4686

SYMBOL	PARAMETER	CONDITIONS	MIN.	TYP.	MAX.	UNIT
<b>Average beam current limiting (note 9)</b>						
$V_{c(15)}$	contrast reduction starting voltage		–	4.0	–	V
$\Delta V_{c(15)}$	voltage difference for full contrast reduction		–	–2.0	–	V
$V_{br(15)}$	brightness reduction starting voltage		–	2.5	–	V
$\Delta V_{br(15)}$	voltage difference for full brightness reduction		–	–1.6	–	V
<b>Peak drive limiting voltage (note 10)</b> internal peak drive limiting level ( $V_{pdl}$ ) acts on RGB outputs $I^2C$ -bus control, sub-address $0A_{Hex}$						
$V_{20/22/24}$	level for minimum RGB outputs	at byte $00_{Hex}$	–	–	3.0	V
	level for maximum RGB outputs	at byte $3F_{Hex}$	7.0	–	–	V
$I_{16}$	charge current		–	–1	–	$\mu A$
	discharge current	during peak white	–	5	–	mA
$V_{16}$	internal voltage limitation		4.5	–	–	V
$V_{c(16)}$	contrast reduction starting voltage		–	4.0	–	V
$\Delta V_{c(16)}$	voltage difference for full contrast reduction		–	–2.0	–	V
$V_{br(16)}$	brightness reduction starting voltage		–	2.5	–	V
$\Delta V_{br(16)}$	voltage difference for full brightness reduction		–	–1.6	–	V
<b>Automatic cut-off control (notes 7, 11, 12 and 13)</b> see Fig.10						
$V_{19}$	external voltage		–	–	$V_P - 1.4$	V
$I_{19}$	output current		–	–	–60	$\mu A$
	input current		150	–	–	$\mu A$
	additional input current	switch-on delay 1	–	0.5	–	mA
$V_{24,22,20}$	monitor pulse amplitude (under $I^2C$ -bus control, sub-address $0A_{Hex}$ )	switch-on delay 1; note 12	–	$V_{pdl} - 1.0$	–	V
$V_{19}$	voltage threshold for picture tube cathode warm-up	switch-on delay 1	–	4.5	–	V
	internally controlled voltage ( $V_{REF}$ )	during leakage measurement period	–	2.7	–	V
$\Delta V_{19}$	voltage difference between $V_{MEAS}$ (cut-off measurement voltage) and $V_{REF}$		–	1.0	–	V

## Video processor with automatic cut-off control

TDA4686

SYMBOL	PARAMETER	CONDITIONS	MIN.	TYP.	MAX.	UNIT
<b>Cut-off storage</b>						
I <sub>21/23/25</sub>	charge and discharge currents	during cut-off measurement lines	–	±0.3	–	mA
	current	outside measurement	–	–	±0.1	µA
<b>Leakage storage</b>						
I <sub>17</sub>	charge and discharge currents	during leakage measurement period	–	±0.4	–	mA
	current	outside measurement	–	–	±0.1	µA
V <sub>17</sub>	threshold voltage for reset to switch-on state		–	2.5	–	V
<b>Hue control</b> (note 14) under I <sup>2</sup> C-bus control, sub-address 03 <sub>Hex</sub> data byte 3F <sub>Hex</sub> for maximum voltage data byte 20 <sub>Hex</sub> for nominal voltage data byte 00 <sub>Hex</sub> for minimum voltage						
V <sub>26</sub>	output voltage	at byte 3F <sub>Hex</sub>	4.8	–	–	V
		at byte 20 <sub>Hex</sub>	–	3.0	–	V
		at byte 00 <sub>Hex</sub>	–	–	1.2	V
I <sub>int</sub>	current of the internal current source at pin 26		500	–	–	µA
<b>I<sup>2</sup>C-bus receiver clock SCL</b> (pin 28)						
f <sub>SCL</sub>	input frequency range		0	–	100	kHz
V <sub>IL</sub>	LOW level input voltage		–	–	1.5	V
V <sub>IH</sub>	HIGH level input voltage		3.0	–	6.0	V
I <sub>IL</sub>	LOW level input current		–	–	–10	µA
I <sub>IH</sub>	HIGH level input current		–	–	10	µA
t <sub>d</sub>	pulse delay time LOW		4.7	–	–	µs
	pulse delay time HIGH		4.0	–	–	µs
t <sub>r</sub>	rise time		–	–	1.0	µs
t <sub>f</sub>	fall time		–	–	0.3	µs
<b>I<sup>2</sup>C-bus receiver data input/output SDA</b> (pin 27)						
V <sub>IL</sub>	LOW level input voltage		–	–	1.5	V
V <sub>IH</sub>	HIGH level input voltage		3.0	–	6.0	V
I <sub>IL</sub>	LOW level input current		–	–	–10	µA
I <sub>IH</sub>	HIGH level input current		–	–	10	µA
I <sub>OL</sub>	LOW level output current		3.0	–	–	mA
t <sub>r</sub>	rise time		–	–	1.0	µs
t <sub>f</sub>	fall time		–	–	0.3	µs
TSU:DAT	data set-up time		0.25	–	–	µs

## Video processor with automatic cut-off control

TDA4686

## Notes to the characteristics

- The values of the  $-(B-Y)$  and  $-(R-Y)$  colour difference input signals are for a 75% colour-bar signal.
- The pins are capacitively coupled to a low ohmic source, with a recommended maximum output impedance of 600  $\Omega$ .
- PAL/SECAM signals are matrixed by the equation:  $V_{G-Y} = -0.51V_{R-Y} - 0.19V_{B-Y}$   
NTSC signals are matrixed by the equations (hue phase shift of  $-5$  degrees):  
 $V_{R-Y}^* = 1.57V_{R-Y} - 0.41V_{B-Y}$ ;  $V_{G-Y}^* = -0.43V_{R-Y} - 0.11V_{B-Y}$ ;  $V_{B-Y}^* = V_{B-Y}$   
In the matrix equations:  $V_{R-Y}$  and  $V_{B-Y}$  are conventional PAL demodulation axes and amplitudes at the output of the NTSC demodulator.  $V_{G-Y}^*$ ,  $V_{R-Y}^*$  and  $V_{B-Y}^*$  are the NTSC-modified colour difference signals; this is equivalent to the following demodulator axes and amplification factors:

	NTSC	PAL
$(B-Y)^*$ demodulator axis	$0^\circ$	$0^\circ$
$(R-Y)^*$ demodulator axis	$115^\circ$	$90^\circ$
$(R-Y)^*$ amplification factor	1.97	1.14
$(B-Y)^*$ amplification factor	2.03	2.03

$$V_{G-Y}^* = -0.27V_{R-Y}^* - 0.22V_{B-Y}^*$$

- The white potentiometers affect the amplitudes of the RGB output signals.
- The RGB outputs at pins 24, 22 and 20 are emitter followers with current sources.
- Sandcastle pulses are compared with internal threshold voltages independent of  $V_p$ . The threshold voltages separate the components of the sandcastle pulse. The particular component is generated when the voltage on pin 14 exceeds the defined internal threshold voltage. The internal threshold voltages (control bit SC5 = 0) are:
  - 1.5 V for horizontal and vertical blanking pulses (H and V blanking pulses),
  - 3.5 V for horizontal pulses,
  - 6.5 V for the burst key pulse.
 The internal threshold voltages, control bit SC5 = 1, are:
  - 1.5 V for horizontal and vertical blanking pulses,
  - 3.5 V for the burst key pulse.
- Vertical signal blanking is determined by the vertical component of the sandcastle pulse. The leakage and the RGB cut-off measurement lines are positioned in the first four complete lines after the end of the vertical component. In this case, the RGB output signals are blanked until the end of the last measurement line; see Fig.10(a). If an extra vertical flyback pulse VFB is applied to pin 18, the four measurement lines start in the first complete line after the end of the VFB pulse; see Fig.10(b). In this case, the output signals are blanked either until the end of the last measurement line or until the end of the vertical component of the sandcastle pulse, according to which occurs last.
- If no VFB pulse is applied, pin 18 should be connected to  $V_p$ . If pin 18 is always LOW neither automatic cut-off control nor output clamping can happen.
- Average beam current limiting reduces the contrast, at minimum contrast it reduces the brightness.
- Peak drive limiting reduces the RGB outputs by reducing the contrast, at minimum contrast it reduces the brightness. The maximum RGB outputs are determined via the  $I^2C$ -bus under sub-address  $0A_{Hex}$ . When an RGB output exceeds the maximum voltage, peak drive limiting is delayed by one horizontal line.
- During leakage current measurement, the RGB channels are blanked to ultra-black level. During cut-off measurement one channel is set to the measurement pulse level, the other channels are blanked to ultra-black. Since the brightness adjust shifts the colour signal relative to the black level, the brightness adjust is disabled during the vertical blanking interval (see Fig.9 and Fig.10).
- During picture cathode warm-up (first switch-on delay) the RGB outputs (pins 24, 22 and 20) are blanked to the ultra-black level during line scan. During the vertical blanking interval a white-level monitor pulse is fed out on the RGB outputs and the cathode currents are measured. When the voltage threshold on pin 19 is greater than 4.5 V, the monitor pulse is switched off and cut-off control is activated (second switch-on delay). As soon as cut-off control stabilizes, RGB output blanking is removed.
- The cut-off measurement level range at the RGB outputs is 1 to 5 V. The recommended value is 3 V.
- The hue control output at pin 26 is an emitter follower with current source.

Video processor with automatic cut-off control

TDA4686

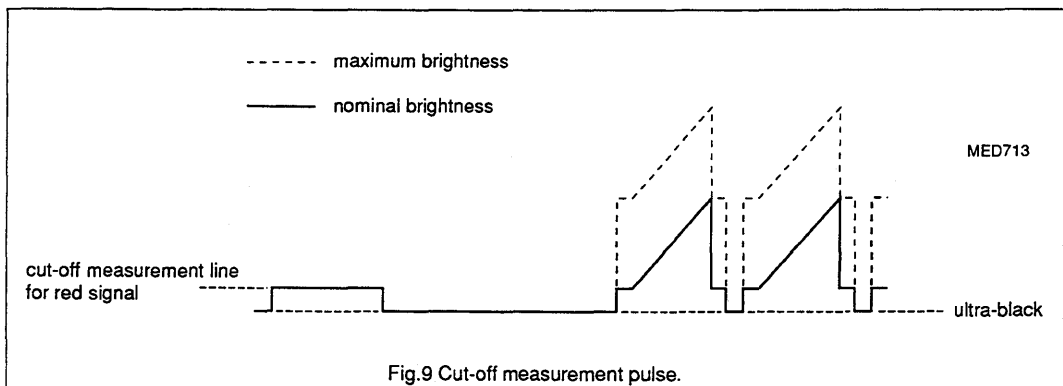
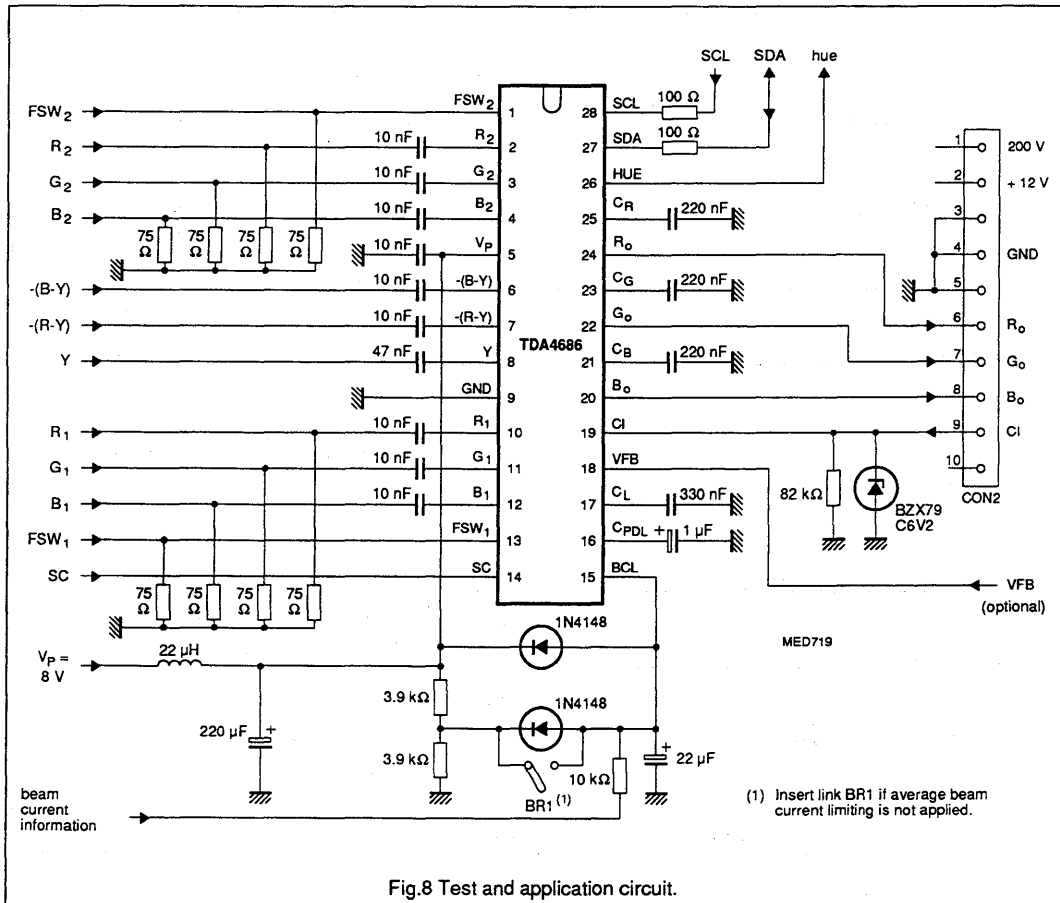

Video processor with automatic cut-off control

TDA4686

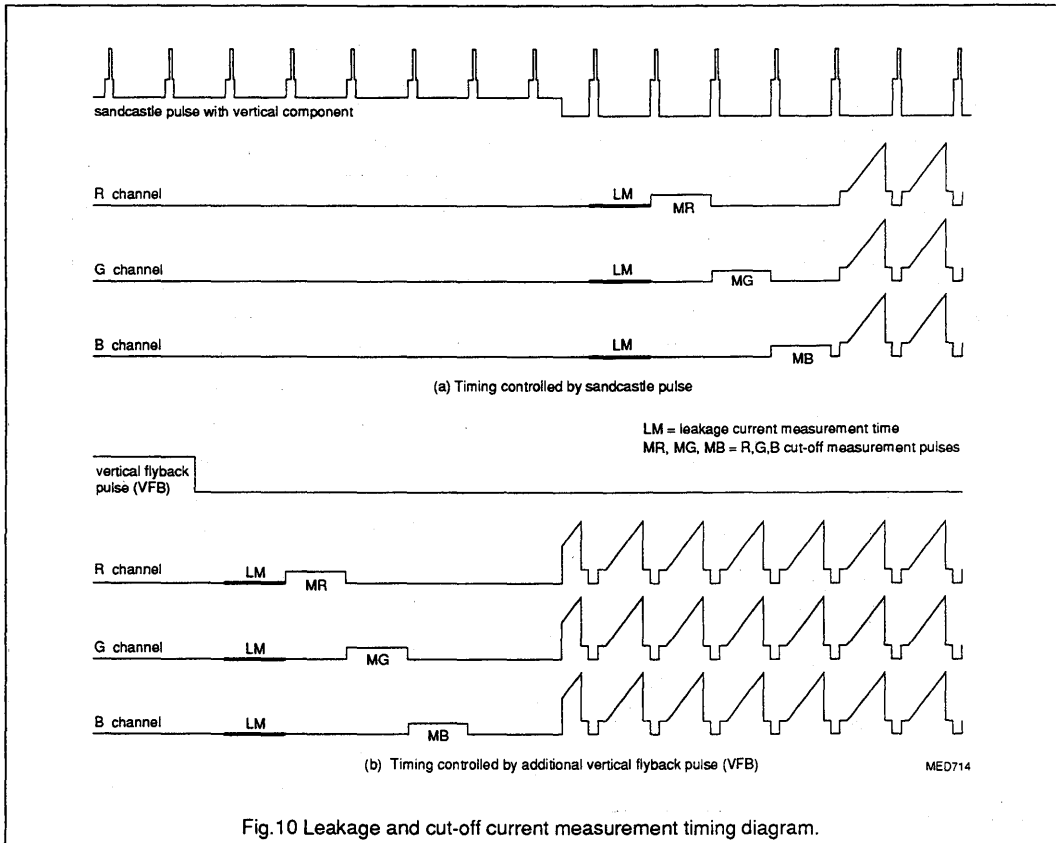

Fig.10 Leakage and cut-off current measurement timing diagram.



## Sync separation circuit for video applications

TDA4820T

## FEATURES

- Fully integrated, few external components
- Positive video input signal, capacitively coupled
- Operates with non-standard video input signals
- Black level clamping
- Generation of composite sync slicing level at 50% of peak sync voltage
- Vertical sync separator with double slope integrator
- Delay time of the vertical output pulse is determined by an external resistor
- Vertical sync generation with a slicing level at 40% of peak sync voltage
- Output stage for composite sync
- Output stage for vertical sync

## GENERAL DESCRIPTION

The TDA4820T is a monolithic integrated circuit including a horizontal and a vertical sync separator, offering composite sync and vertical sync extracted from the video signal.

## QUICK REFERENCE DATA

SYMBOL	PARAMETER	CONDITIONS	MIN.	TYP.	MAX.	UNIT
$V_P$	supply voltage range (pin 1)		10.8	12	13.2	V
$I_P$	supply current (pin 1)		—	8	12	mA
$V_{2(p-p)}$	input voltage amplitude (peak-to-peak value)		0.2	1	3	V
$V_{\text{sync}(p-p)}$	sync pulse input voltage amplitude (pin 2) (peak-to-peak value)		50	300	500	mV
$V_o$	maximum vertical sync output voltage (pin 6)	$I_6 = -1 \text{ mA}$	10.0	—	—	V
$V_o$	maximum composite sync output voltage (pin 7)	$I_7 = -3 \text{ mA}$	10.0	—	—	V
$V_o$	minimum output voltage (pins 6 and 7)	$I_{6,7} = 1 \text{ mA}$	—	—	0.6	V
$T_{\text{amb}}$	operating ambient temperature range		0	—	+ 70	°C

## ORDERING AND PACKAGE INFORMATION

EXTENDED TYPE NUMBER	PACKAGE			
	PINS	PIN POSITION	MATERIAL	CODE
TDA4820T	8	mini-pack	plastic	SO8; SOT96A

Sync separation circuit for video applications

TDA4820T

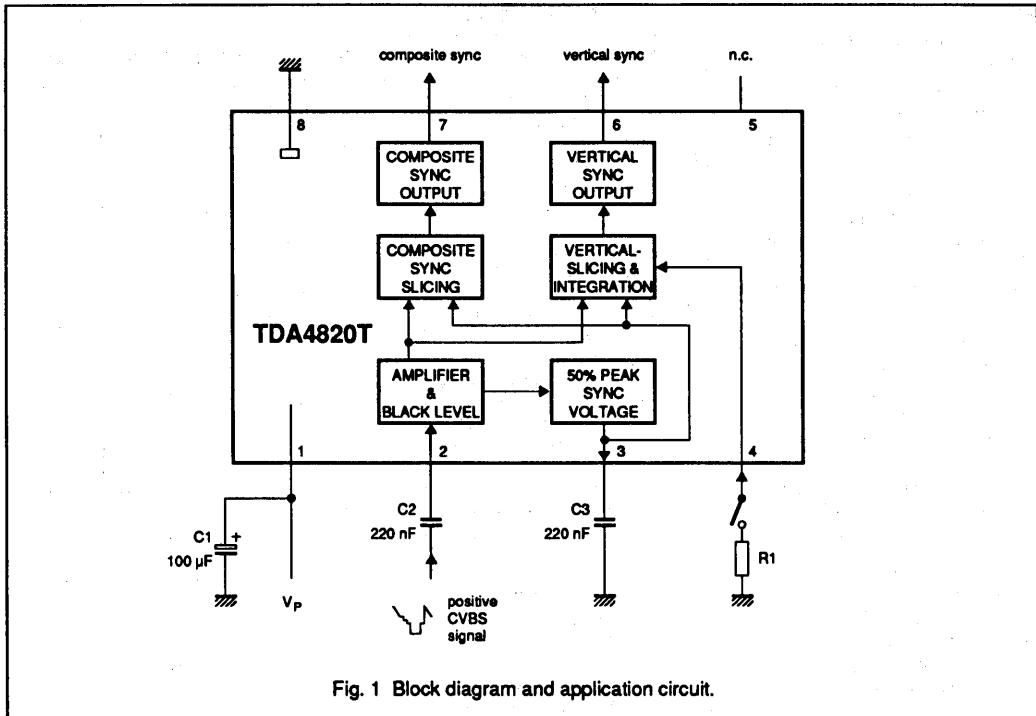

**PINNING**

SYMBOL	PIN	DESCRIPTION
V <sub>P</sub>	1	supply voltage
V <sub>CVBS</sub>	2	video input signal
SLEV	3	slicing level
VDEL	4	vertical integration delay time
n.c.	5	not connected
VSYN	6	vertical sync output signal
CSYN	7	composite sync output signal
GND	8	ground

**PIN CONFIGURATION**

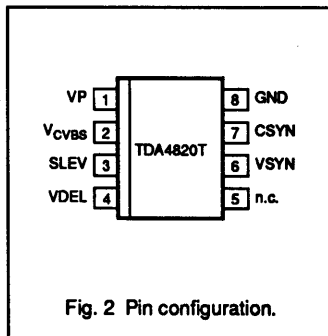

## Sync separation circuit for video applications

TDA4820T

**FUNCTIONAL DESCRIPTION**

The complete circuit consists of the following functional blocks as shown in Fig.1:

- Video amplifier and black level clamping
- 50% peak sync voltage
- Composite sync slicing
- Vertical slicing and double slope integrator
- Vertical sync output
- Composite sync output

**Video amplifier and black level clamping (pin 2)**

The sync separation circuit TDA4820T is designed for positive video input signals.

The video signal (supplied via capacitor C2 at pin 2) is amplified by approximately 15 in the input amplifier. The black level clamping voltage (approximately 2 V) is stored by capacitor C2.

**50% peak sync voltage (pin 3)**

From the black level and the peak sync voltage, the 50% value of the peak sync voltage is generated and stored by capacitor C3 at pin 3.

A slicing level control circuit ensures a constant 50% value, as long as the sync pulse amplitude at pin 2 is between 50 mV and 500 mV, independent of the amplitude of the picture content.

**Composite sync slicing**

A comparator in the composite sync slicing stage compares the amplified video signal with the DC voltage derived from 50% peak sync voltage. This generates the composite sync output signal.

**Vertical slicing and double slope integrator**

Vertical slicing compares the composite sync signal with a DC level equal to 40 % of the peak sync

voltage, similar to the composite sync slicing.

With signal interference (reflections or noise) the reduced vertical slicing level ensures more energy for the vertical pulse integration. The slope is double-integrated to eliminate the influence of signal interference.

The vertical integration delay time  $t_{dV}$  can be set from typically 45  $\mu$ s (pin 4 open) to typically 18  $\mu$ s (pin 4 grounded). Between these maximum

and minimum values,  $t_{dV}$  can be set by a resistor R1 from pin 4 to ground. For optimum sync behaviour with input line sync pulses only, R1 has to be  $\geq 3.3$  k $\Omega$ . In this case  $t_{dV}$  is typically  $\geq 23$   $\mu$ s.

**Vertical sync output****Composite sync output**

Both output stages are emitter followers with bias currents of 2 mA.

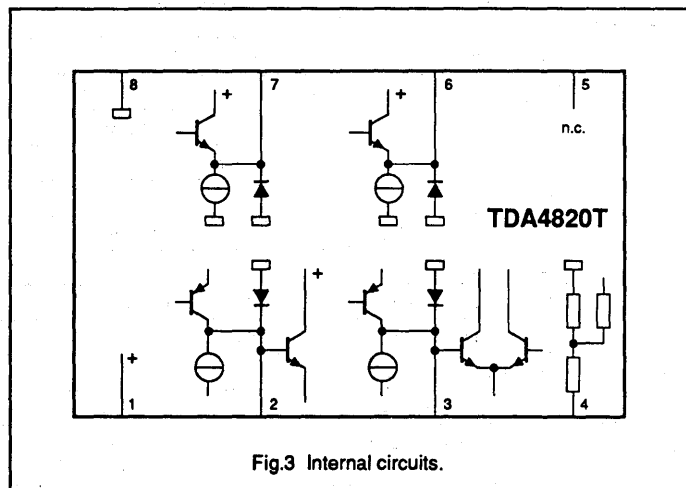

Fig.3 Internal circuits.

**LIMITING VALUES**

In accordance with the Absolute Maximum System (IEC 134)

SYMBOL	PARAMETER	MIN.	MAX.	UNIT
$V_P$	supply voltage (pin 1)	0	13.2	V
$V_I$	input voltage (pin 2)	-0.5	6	V
$I_o$	output current (pin 6 and pin 7)	3	-10	mA
$T_{stg}$	storage temperature range	-25	+ 150	$^{\circ}$ C
$T_{amb}$	operating ambient temperature range	0	+ 70	$^{\circ}$ C
$T_J$	maximum junction temperature	-	150	$^{\circ}$ C
$P_{tot}$	total power dissipation	-	500	mW

## Sync separation circuit for video applications

TDA4820T

**CHARACTERISTICS**All voltages measured to GND (pin 8);  $V_P = 12\text{ V}$ ;  $T_{\text{amb}} = 25\text{ }^\circ\text{C}$ ; unless otherwise specified.

SYMBOL	PARAMETER	CONDITIONS	MIN.	TYP.	MAX.	UNIT
$V_P$	supply voltage range (pin 1)		10.8	12.0	13.2	V
$I_P$	supply current (pin 1)		4	8	12	mA
<b>Video amplifier</b>						
$V_{2(p-p)}$	input amplitude (peak-to-peak value)	positive video signal AC coupled	0.2	1	3	V
$V_{\text{sync (p-p)}}$	sync pulse amplitude (pin 2) (peak-to-peak value)	composite sync slicing level 50% for $0.2\text{ V} \leq V_{2(p-p)} \leq 1.5\text{ V}$	50	300	500	mV
$Z_S$	source impedance		–	–	200	$\Omega$
<b>Black level clamping</b>						
$I_2$	discharge current of C2	during video content	–	5	–	$\mu\text{A}$
	charge currents of C2	sync below slicing level	–	–40	–	$\mu\text{A}$
		sync above slicing level	–	–25	–	$\mu\text{A}$
		during black level	–	–20	–	$\mu\text{A}$
<b>50% peak sync voltage</b>						
$I_3$	discharge current of C3	during video content	–	16	–	$\mu\text{A}$
	maximum charge current of C3		–	–345	–	$\mu\text{A}$
	reduced charge current of C3	during vertical sync	–	–255	–	$\mu\text{A}$
	charge current of C3	during sync pulse	–	–160	–	$\mu\text{A}$
<b>Composite sync slicing (see Fig.4)</b>						
	composite sync slicing level	$0.2\text{ V} \leq V_{2(p-p)} \leq 1.5\text{ V}$	–	50	–	%
$t_{dH}$	horizontal delay time (pin 7)	maximum load at pin 7: $C_L \leq 5\text{ pF}$ ; $R_L \geq 100\text{ k}\Omega$	–	250	500	ns
<b>Vertical sync separation (see Fig.5)</b>						
	slicing level for vertical sync	$0.2\text{ V} \leq V_{2(p-p)} \leq 1.5\text{ V}$	–	40	–	%
$t_{dV}$	vertical leading edge delay times (pin 6)	pin 4 open	30	45	60	$\mu\text{s}$
		pin 4 grounded	11	18	25	$\mu\text{s}$
<b>Vertical and composite sync outputs</b>						
$V_o$	maximum vertical sync output voltage (pin 6)	$I_6 = -1\text{ mA}$	10.0	10.5	11.5	V
$V_o$	maximum composite sync output voltage (pin 7)	$I_7 = -3\text{ mA}$	10.0	10.5	11.5	V
$V_o$	minimum output voltages (pins 6 and 7)	$I_{6,7} = 1\text{ mA}$	0.1	0.3	0.6	V
$t_W$	vertical sync pulse width	pin 4 open; standard signal of 625 lines	–	180	–	$\mu\text{s}$

Sync separation circuit for video applications

TDA4820T

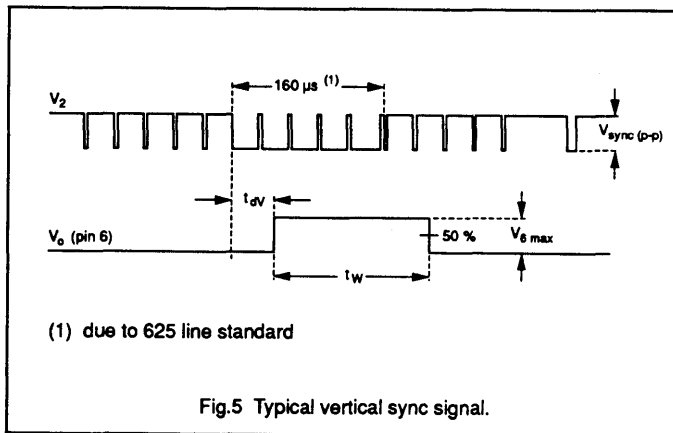
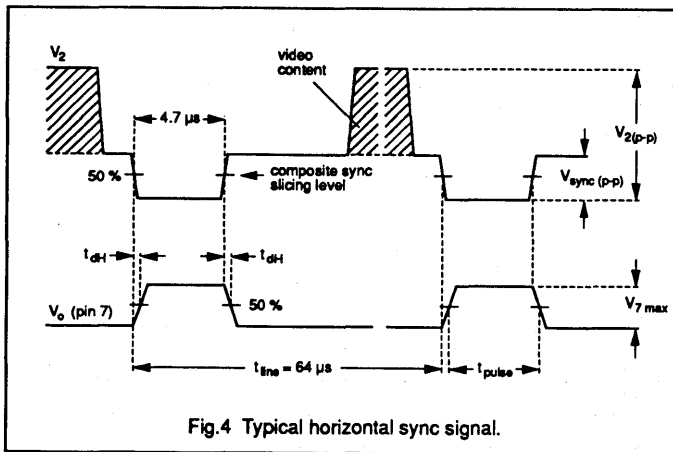

# Octuple 6-bit DAC with I<sup>2</sup>C-bus

# TDA8444/AT/T

## GENERAL DESCRIPTION

The TDA8444/AT/T comprises eight digital-to-analog converters (DSCs), each controlled via the two-wire I<sup>2</sup>C-bus. The DACs are individually programmed using a 6-bit word to select an output from one of 64 voltage steps. The maximum output voltage

of all DACs is set by the input  $V_{max}$  and the resolution is approximately  $V_{max}/64$ . At power-on all DAC outputs are set to their lowest value. The I<sup>2</sup>C-bus slave receiver has a 7-bit address of which 3 bits are programmable via pins A0, A1 and A2.

## FEATURES

- Eight discrete DACs
- I<sup>2</sup>C-bus slave receiver
- 16-pin DIL package
- 16-pin SO package
- 20-pin SO package



## QUICK REFERENCE DATA

SYMBOL	PARAMETER	CONDITIONS	MIN.	TYP.	MAX.	UNIT
$V_P$	Supply voltage		4.5	12.0	13.2	V
$I_{CC}$	Supply current	no loads; $V_{max} = V_P$ ; all data = 00	0	12	15	mA
$P_{tot}$	Total power dissipation	no loads; $V_{max} = V_P$ ; all data = 00	–	150	–	mW
$V_{max}$	Effective range of $V_{max}$ input	$V_P = 12V$	1	–	10.5	V
$V_O$	DAC output voltage range		0.1	–	$V_P - 0.5$	V
$V_{LSB}$	Step value of 1 LSB	$V_{max} = V_P$ ; $I_O = -2mA$	70	160	250	mV

## PACKAGE OUTLINES

TDA8444 16-lead DIL; plastic (SOT38)  
 TDA8444T 16-lead SO; plastic (SOT-162)  
 TDA8444AT 20-lead SO; (SOT-163)

# Octuple 6-bit DAC with I<sup>2</sup>C-bus

# TDA8444/AT/T

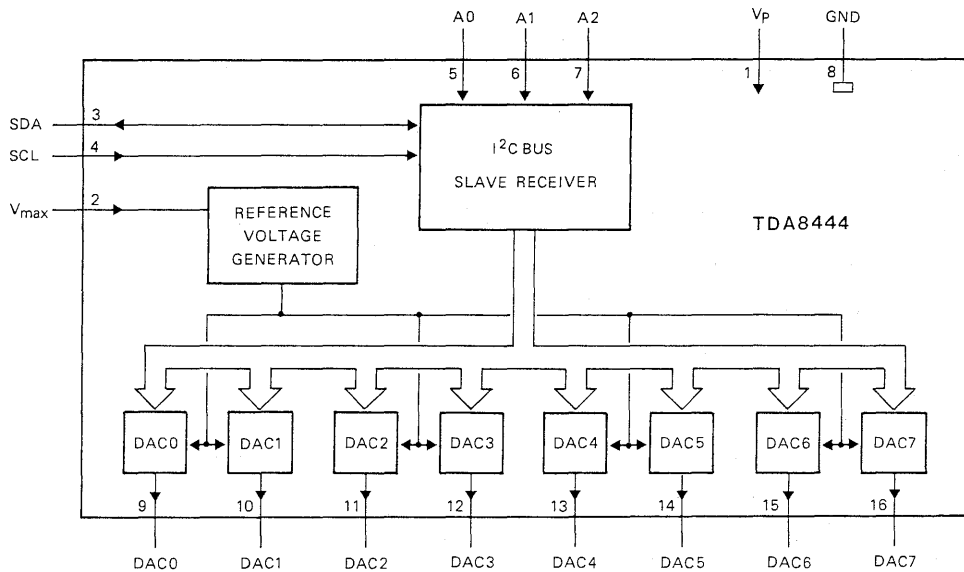
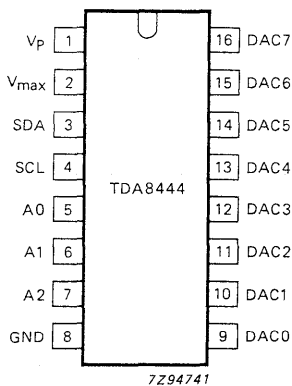

Fig. 1 Block diagram.

7Z94743

## PINNING



7Z94741

- |      |                  |   |
|------|------------------|---|
| 1    | V <sub>p</sub>   | positive supply voltage   |
| 2    | V <sub>max</sub> | control input for DAC maximum output voltage                      |
| 3    | SDA              | I <sup>2</sup> C-bus serial data input/output                     |
| 4    | SCL              | I <sup>2</sup> C-bus serial data clock                            |
| 5    | A0               | programmable address bits for I <sup>2</sup> C-bus slave receiver |
| 6    | A1               |   |
| 7    | A2               |   |
| 8    | GND              | ground  |
| 9-16 | DAC0-7           | analogue voltage outputs  |

Fig. 2 Pinning diagram.

# Octuple 6-bit DAC with I<sup>2</sup>C-bus

TDA8444/AT/T

## BLOCK DIAGRAM – TDA8444AT (SO-20)

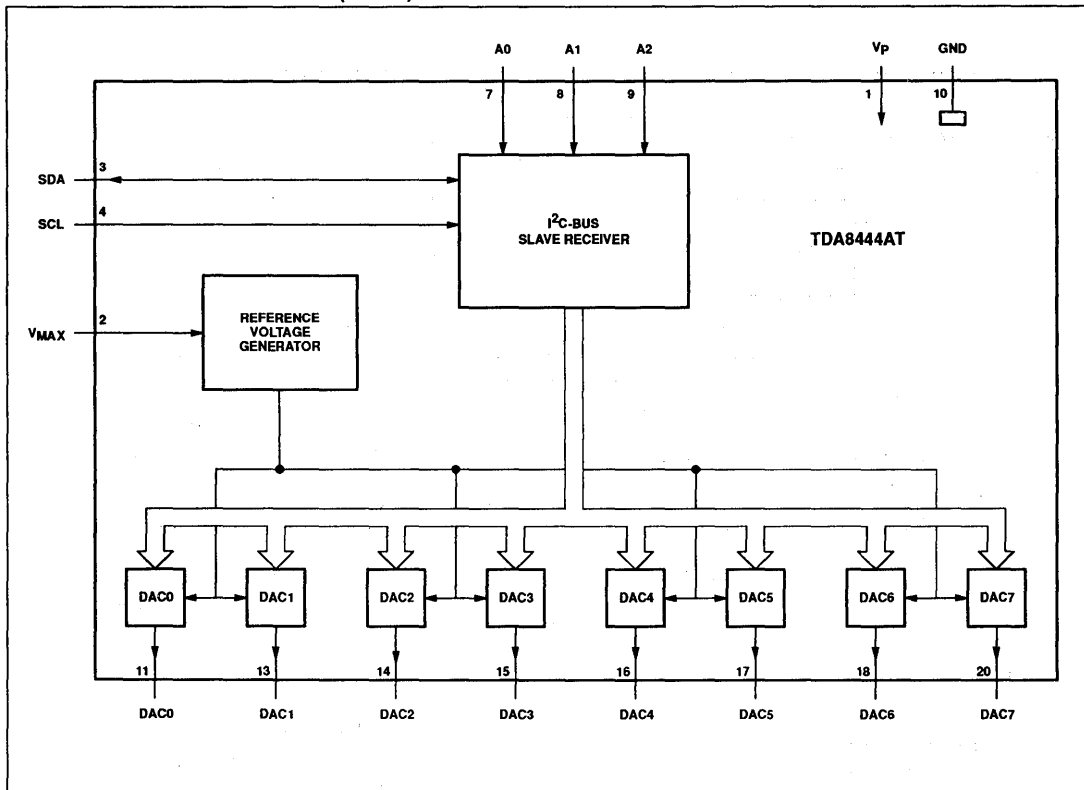

## PIN CONFIGURATION AND DESCRIPTION – TDA8444AT (SO-20, SOT-163)

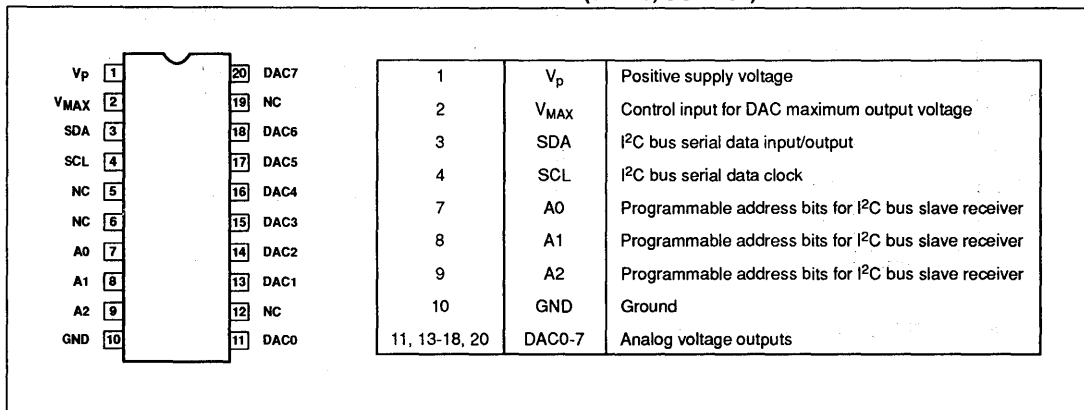



# Octuple 6-bit DAC with I<sup>2</sup>C-bus

TDA8444/AT/T

## BLOCK DIAGRAM – TDA8444T (SO-16)

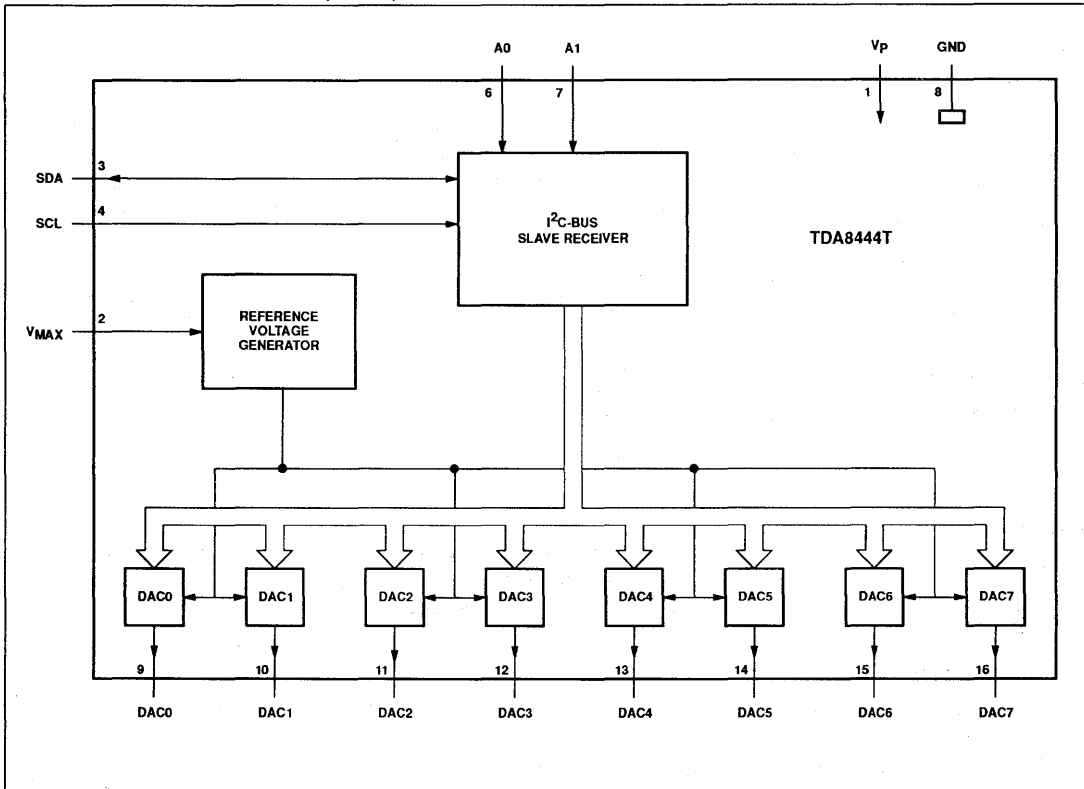

## PIN CONFIGURATION AND DESCRIPTION – TDA8444T (SO-16, SOT-162)

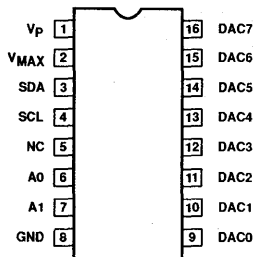

1	V <sub>p</sub>	Positive supply voltage
2	V <sub>MAX</sub>	Control input for DAC maximum output voltage
3	SDA	I <sup>2</sup> C bus serial data input/output
4	SCL	I <sup>2</sup> C bus serial data clock
6	A0	Programmable address bits for I <sup>2</sup> C bus slave receiver
7	A1	Programmable address bits for I <sup>2</sup> C bus slave receiver
8	GND	Ground
9-16	DAC0-7	Analog voltage outputs

Octuple 6-bit DAC with I<sup>2</sup>C-bus

TDA8444/AT/T

## FUNCTIONAL DESCRIPTION

I<sup>2</sup>C-bus

The TDA8444 I<sup>2</sup>C-bus interface is a receive-only slave. Data is accepted from the I<sup>2</sup>C-bus in the following format:

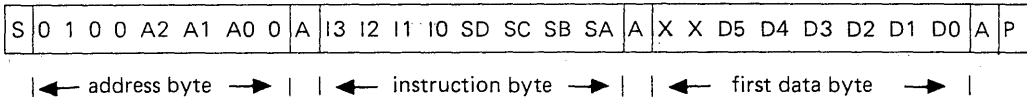

Where:

S = start condition	A2, A1, A0	= programmable address bits
P = stop condition	I3, I2, I1, I0	= instruction bits
A = acknowledge	SD, SC, SB, SA	= subaddress bits
X = don't care	D5, D4, D3, D2, D1, D0	= data bits

Fig. 3 Data format.

## Address byte

Valid addresses are 40, 42, 44, 46, 48, 4A, 4C, 4E (hexadec), depending on the programming of bits A2, A1 and A0. With these addresses, up to eight TDA8444 ICs can be operated independently from one I<sup>2</sup>C-bus. No other addresses are acknowledged by the TDA8444.

## Instruction and data bytes

Valid instructions are 00 to 0F and F0 to FF (hexadec); the TDA8444 will not respond to other instruction values.

Instructions 00 to 0F cause auto-incrementing of the subaddress (bits SD to SA) when more than one data byte is sent within one transmission. With auto-incrementing, the first data byte is written into the DAC addressed by bits SD to SA and then the subaddress is automatically incremented by one position for the next data byte in the series.

Auto-incrementation does not occur with instructions F0 to FF. Other than auto-incrementation there is no difference between instructions 00 to 0F and F0 to FF. When only one data byte per transmission is present, the DAC addressed by the subaddress will always receive the data.

Valid subaddresses (bits SD to SA) are 0 to 7 (hexadec) relating numerically to DAC0 to DAC7. When the auto-incrementing function is used, the subaddress will sequence through all possible values (0 to F, 0 to F, etc.).

I<sup>2</sup>C-bus

Input SCL (pin 3) and input/output SDA (pin 4) conform to I<sup>2</sup>C-bus specifications.\* Pins 3 and 4 are protected against positive voltage pulses by internal zener diodes connected to the ground plane and therefore the normal bus line voltage should not exceed 5.5 V.

The address inputs A0, A1, A2 are programmed by a connection to GND for A<sub>n</sub> = 0 or to V<sub>p</sub> for A<sub>n</sub> = 1. If the inputs are left floating, A<sub>n</sub> = 1 will result.

Octuple 6-bit DAC with I<sup>2</sup>C-bus

TDA8444/AT/T

## FUNCTIONAL DESCRIPTION (continued)

Input  $V_{\max}$ 

Input  $V_{\max}$  (pin 2) provides a means of compressing the output voltage swing of the DACs. The maximum DAC output voltage is restricted to approximately  $V_{\max}$  while the 6-bit resolution is maintained, so giving a finer voltage resolution of smaller output swings.

## Digital-to-analogue converters

Each DAC comprises a 6-bit data latch, current switches and an output driver. Current sources with values weighted by  $2^0$  up to  $2^5$  are switched according to the data input so that the sum of the selected currents gives the required analogue voltage from the output driver. The range of the output voltage is approximately 0.5 to 10.5 V when  $V_{\max} = V_p$ .

The DAC outputs are protected against short-circuits to  $V_p$  and GND.

To avoid the possibility of oscillations, capacitive loading at the DAC outputs should not exceed 2 nF.

## RATINGS

Limiting values in accordance with the Absolute Maximum System (IEC 134)

parameter	conditions	symbol	min.	max.	unit
Supply voltage		$V_p = V_1$	-0.5	18	V
Supply current (source)		$I_p = I_1$	-	-10	mA
		$I_p = I_1$	-	40	mA
I <sup>2</sup> C-bus line voltage		$V_{3,4}$	-0.5	5.9	V
Input voltage		$V_I$	-0.5	$V_p + 0.5$	V
Output voltage		$V_O$	-0.5	$V_p + 0.5$	V
Maximum current on any pin (except pins 1 and 8)		$\pm I_{\max}$	-	10	mA
Total power dissipation		$P_{\text{tot}}$	-	500	mW
Operating ambient temperature range		$T_{\text{amb}}$	-20	+70	°C
Storage temperature range		$T_{\text{stg}}$	-65	+150	°C

## THERMAL RESISTANCE

From junction to ambient

 $R_{\text{th j-a}}$ 

75 K/W



Purchase of Philips' I<sup>2</sup>C components conveys a license under the Philips' I<sup>2</sup>C patent to use the components in the I<sup>2</sup>C-system provided the system conforms to the I<sup>2</sup>C specifications defined by Philips.

Octuple 6-bit DAC with I<sup>2</sup>C-bus

TDA8444/AT/T

## CHARACTERISTICS

All voltages are with respect to GND;  $T_{amb} = 25\text{ }^{\circ}\text{C}$ ;  $V_p = 12\text{ V}$  unless otherwise specified

parameter	conditions	symbol	min.	typ.	max.	unit
Supply voltage		$V_p$	4.5	12.0	13.2	V
Voltage level for power-on reset		$V_1$	1	—	4.8	V
Supply current	no loads; $V_{max} = V_p$ ; all data = 00	$I_p = I_1$	8	12	15	mA
Total power dissipation	no loads; $V_{max} = V_p$ ; all data = 00	$P_{tot}$	—	150	—	mW
Effective range of $V_{max}$ input (pin 2)	$V_p = 12\text{ V}$	$V_{max} = V_2$	1.0	—	10.5	V
Pin 2 current	$V_2 = 1\text{ V}$	$I_2$	—	—	-10	$\mu\text{A}$
	$V_2 = V_p$	$I_2$	—	—	10	$\mu\text{A}$
<b>SDA, SCL inputs</b> (pins 3 and 4)						
Input voltage range		$V_1$	0	—	5.5	V
Input voltage LOW		$V_{1L}$	—	—	1.5	V
Input voltage HIGH		$V_{1H}$	3.0	—	—	V
Input current LOW	$V_{3,4} = 0.3\text{ V}$	$I_{1L}$	—	—	-10	$\mu\text{A}$
Input current HIGH	$V_{3,4} = 6\text{ V}$	$I_{1H}$	—	—	$\pm 10$	$\mu\text{A}$
<b>SDA output</b> (pin 3)						
Output voltage LOW	$I_3 = 3\text{ mA}$	$V_{OL}$	—	—	0.4	V
Sink current		$I_O$	3	8	—	mA
<b>Address inputs</b> (pins 5 to 7)						
Input voltage range		$V_1$	0	—	$V_p$	V
Input voltage LOW		$V_{1L}$	—	—	1	V
Input voltage HIGH		$V_{1H}$	2.1	—	—	V
Input current LOW		$I_{1L}$	—	-7	-12	$\mu\text{A}$
Input current HIGH		$I_{1H}$	—	—	1	$\mu\text{A}$

Octuple 6-bit DAC with I<sup>2</sup>C-bus

TDA8444/AT/T

## CHARACTERISTICS (continued)

parameter	conditions	symbol	min.	typ.	max.	unit
<b>DAC outputs</b> (pins 9 to 16)						
Output voltage range		$V_O$	0.1	—	$V_p - 0.5$	V
Minimum output voltage	data = 00; $I_O = -2$ mA	$V_{Omin}$	0.1	0.4	0.8	V
Maximum output voltage	data = 3F; $I_O = -2$ mA	$V_{Omax}$	10	10.5	11.5	V
at $V_{max} = V_p$		$V_{Omax}$		see note		V
at $1 < V_{max} < 10.5$ V						
Output sink current	$V = V_p$ ; data = 1F	$I_O$	2	8	15	mA
Output source current	$V = 0V$ ; data = 1F	$I_O$	-2	—	-6	mA
Output impedance	data = 1F; $-2 < I_O < +2$ mA	$Z_O$	—	4	50	$\Omega$
Step value of 1 LSB	$V_{max} = V_p$ ; $I_O = -2$ mA	$V_{LSB}$	70	160	250	mV
Deviation from linearity	$I_O = -2$ mA; $N \neq 32$		0	—	50	mV
Deviation from linearity	$I_O = -2$ mA; $N = 32$		0	—	70	mV

## Note to the characteristics

$$V_O = 0.95 V_{max} + V_{Omin}$$

Octuple 6-bit DAC with I<sup>2</sup>C-bus

TDA8444/AT/T

APPLICATION INFORMATION

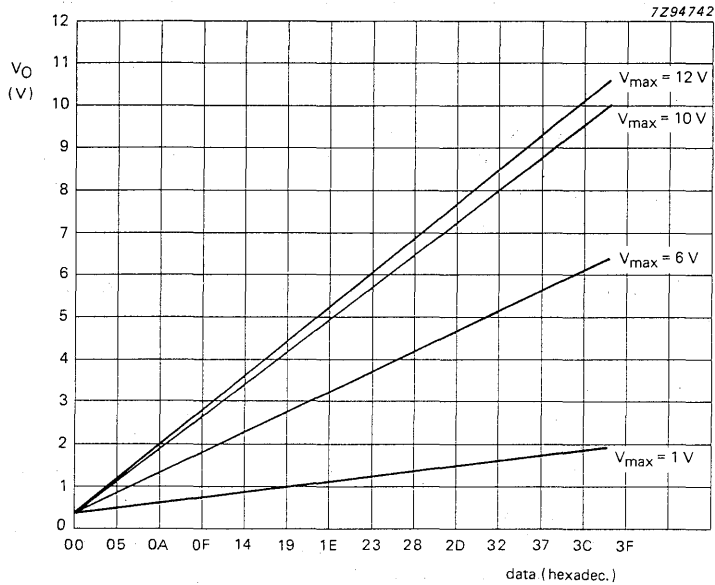

Fig. 4 Graph showing output voltage as a function of the input data value for V<sub>max</sub> values of 1, 6, 10 and 12 V; V<sub>p</sub> = 12 V.

## Fast RGB/YC switch for digital decoding

## TDA8446; TDA8446T

### FEATURES

- R, G, B clamped inputs
- Luminance and chrominance difference matrix
- Y-clamped inputs
- Fast switching between internal and external Y
- Chrominance input
- Amplifier with selectable gain
- 3-state switch for chrominance output

### APPLICATIONS

- Digital TV systems
- Desktop video architecture

### DESCRIPTION

The TDA8446 is a video switch which is designed for use in the DMSD digital video system (DMSD = Digital Multistandard System Decoder). The device is intended for matrixing incoming RGB signals and for switching between luminance signals. It generates SYNC signal and TTL clamping pulses from any video signal with sync pulses.

### QUICK REFERENCE DATA

SYMBOL	PARAMETER	MIN.	TYP.	MAX.	UNIT
$V_{CC}$	positive supply voltage range	10.8	–	13.2	V
$T_{amb}$	operating ambient temperature range	0	–	+70	°C

### ORDERING INFORMATION

EXTENDED TYPE NUMBER	PACKAGE			
	PINS	PIN POSITION	MATERIAL	CODE
TDA8446	20	DIL	plastic	SOT146E
TDA8446T	28	SO28L	plastic	SOT136A

Fast RGB/YC switch for digital decoding

TDA8446; TDA8446T

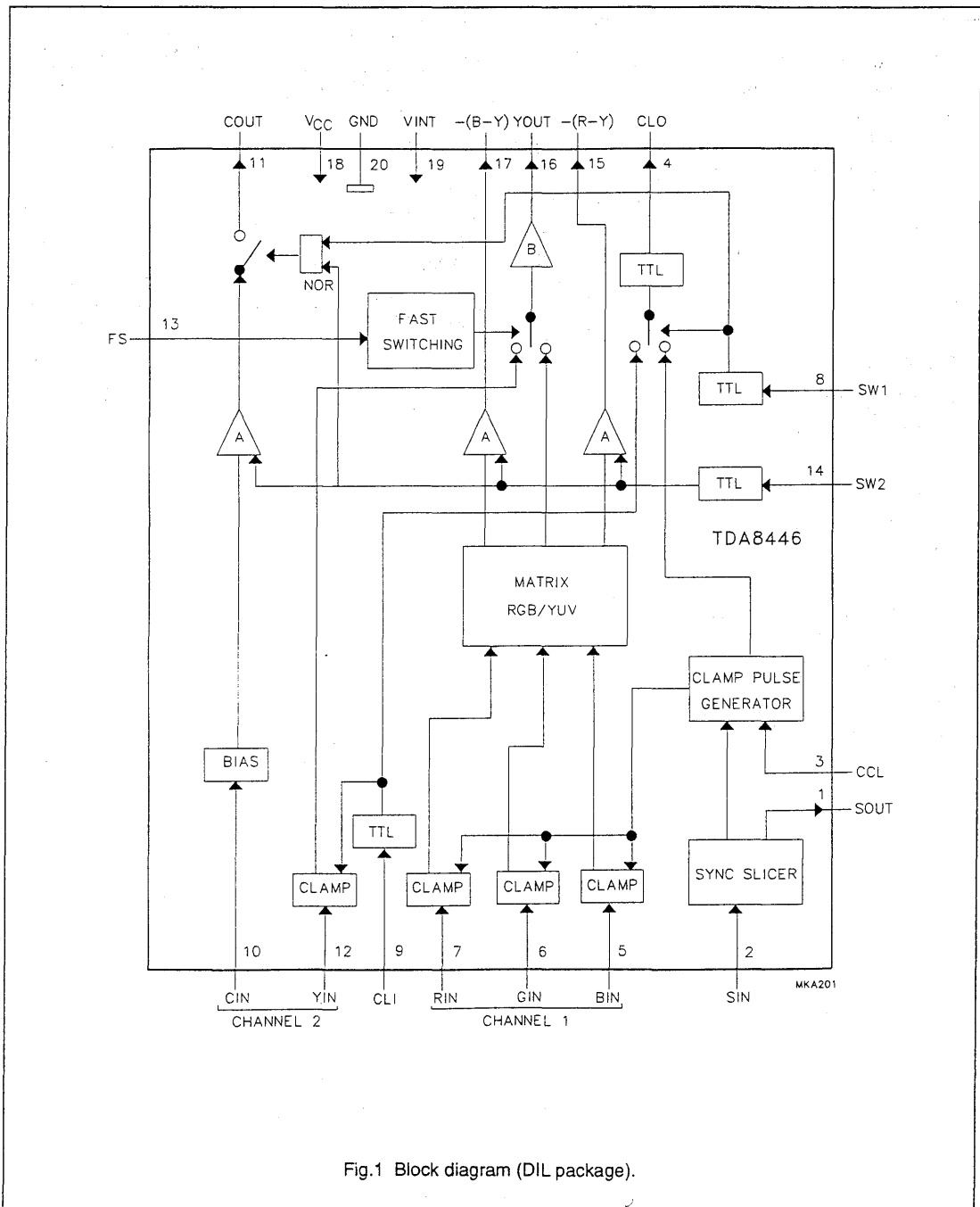

Fig.1 Block diagram (DIL package).



# Fast RGB/YC switch for digital decoding

TDA8446; TDA8446T

## PINNING

SYMBOL	PIN		DESCRIPTION
	DIL	SO	
SOUT	1	1	synchronization signal output; this output provides the synchronization information extracted from the incoming signal at pin 2 (SIN)
SIN	2	2	synchronization signal input; CSYNC or CVBS signal from the video-connector
CCL	3	3	clamping capacitor connection; the clamping pulse is generated by external circuitry connected to this pin; the generated pulse clamps the RGB inputs
n.c.	–	4	not connected
CLO	4	5	clamping pulse output
n.c.	–	6	not connected
BIN	5	7	B-signal input
GIN	6	8	G-signal input
RIN	7	9	R-signal input
SW1	8	10	clamping control signal input; this TTL signal is used to select the clamp signal; a LOW level at this input forces the circuit to output the generated clamping pulse
n.c.	–	11	not connected
CLI	9	12	clamping pulse input; this TTL signal indicates the black level clamping period for the incoming Y signal (active HIGH)
CIN	10	13	chrominance signal input
COUT	11	14	chrominance signal output
YIN	12	15	luminance signal input; this input also accepts the CVBS signal
FS	13	16	fast switching signal input; this signal is used to control fast switching of the luminance signals; a HIGH level at this input forces the circuit to output the internal Y
n.c.	–	17	not connected
n.c.	–	18	not connected
SW2	14	19	gain control signal input; this TTL signal is used to fix the gain of the chrominance amplifiers (A); a LOW level at this input forces the gain A at 6 dB, (HIGH forces 0 dB)
n.c.	–	20	not connected
–(R-Y)	15	21	–(R-Y) signal output
YOUT	16	22	luminance signal output
–(B-Y)	17	23	–(B-Y) signal output
n.c.	–	24	not connected
n.c.	–	25	not connected
V <sub>CC</sub>	18	26	positive supply voltage (+12 V)
VINT	19	27	internal decoupling
GND	20	28	ground

Fast RGB/YC switch for digital decoding

TDA8446; TDA8446T

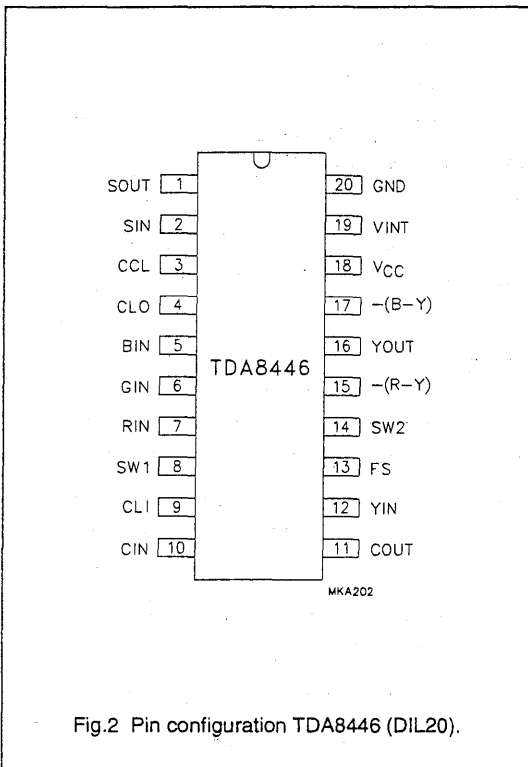

Fig.2 Pin configuration TDA8446 (DIL20).

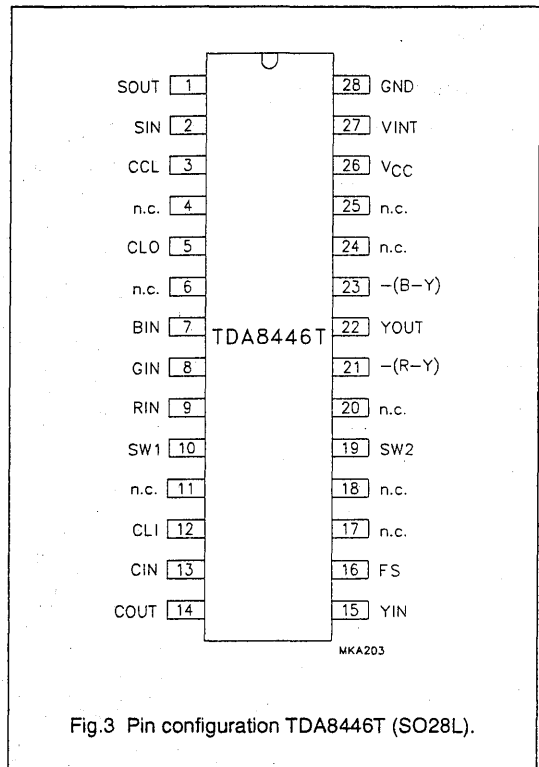

Fig.3 Pin configuration TDA8446T (SO28L).

LIMITING VALUES

In accordance with the Absolute Maximum Rating System (IEC134)

SYMBOL	PARAMETER	MIN.	MAX.	UNIT
V <sub>CC</sub>	positive supply voltage range	-0.3	+14	V
V <sub>I</sub>	input voltage	-0.3	+12.3	V
T <sub>stg</sub>	storage temperature range	-55	+125	°C

HANDLING

Each pin will withstand the ESD test in accordance with MIL-STD-883C class 2 (2000 V to 2999 V). Method 3015 (HBM 1500 Ω, 100 pF) 3 pulses + and 3 pulses - on each pin as a function of ground.

# Fast RGB/YC switch for digital decoding

TDA8446; TDA8446T

## OPERATING CHARACTERISTICS

SYMBOL	PARAMETER	MIN.	TYP.	MAX.	UNIT
<b>Supply/temperature</b>					
$V_{CC}$	positive supply voltage range	10.8	-	13.2	V
$T_{amb}$	operating ambient temperature range	0	-	+70	°C
<b>TTL inputs (SW1, SW2 and CLI)</b>					
$V_{IH}$	HIGH level input voltage	2	-	$V_{CC}$	V
$V_{IL}$	LOW level input voltage	-0.3	-	+0.8	V
<b>SYNC signal (SIN)</b>					
$V_{S(p-p)}$	sync amplitude	0.2	-	2.5	V
<b>Fast Switching input (FS)</b>					
$V_{IH}$	HIGH level input voltage	1	-	3	V
$V_{IL}$	LOW level input voltage	-	-	0.4	V
<b>Video inputs (RIN, GIN, BIN, CIN, YIN)</b>					
$V_{I(p-p)}$	peak-to-peak video amplitude on RIN, GIN and BIN inputs	-	0.7	1	V
$C_I$	input capacitance	-	100	-	nF
<b>Clamping pulse generator (CCL)</b>					
$R_{CP}$	clamping resistance	-	4.7	-	k $\Omega$
$C_{CP}$	clamping capacitance	-	1	-	nF

## CHARACTERISTICS

$V_{CC} = 12$  V;  $T_{amb} = 25$  °C; unless otherwise specified

SYMBOL	PARAMETER	CONDITIONS	MIN.	TYP.	MAX.	UNIT
<b>Supply</b>						
$I_{CC}$	supply current		-	-	80	mA
RR	supply voltage rejection ratio	note 1	30	-	-	dB
<b>Y and R, G, B channels</b>						
$I_{CL}$	input clamping current	$V_{CC} = 6$ V; $V_I = 0$ V	0.3	-	-	mA
$I_I$	input current	$V_I = 9$ V	-1.5	0.5	+1.5	$\mu$ A
$G_A$	gain of amplifier A	$f = 1$ MHz; $V_{SW2} = 2.0$ V	-1	0	+1	dB
		$V_{SW2} = 0.8$ V	+5	+6	+7	dB
$G_B$	gain of amplifier B	$f = 1$ MHz	-1	0	+1	dB
	RGB matrixed according to the equations: $Y = 0.30R + 0.59G + 0.11B$ $R - Y = 0.70R - 0.59G + 0.11B$ $B - Y = -0.30R - 0.59G + 0.89B$					
$\Delta G$	relative gain difference	note 2	-	0	10	%
$ \Delta G $	maximum gain variation	100 kHz < $f$ < 8 MHz	-	3	-	dB
$R_O$	output resistance		-	15	-	$\Omega$

## Fast RGB/YC switch for digital decoding

TDA8446; TDA8446T

SYMBOL	PARAMETER	CONDITIONS	MIN.	TYP.	MAX.	UNIT
$\Delta t$	time difference at output	$f = 1 \text{ MHz}$ ; note 3	-	-	25	ns
$V_O$	DC output level	$V_{CC} = 6 \text{ V}$	-	4.2	-	V
$t_{\text{isd}}$	fast switching delay	see Fig.4	-	20	-	ns
$t_s$	fast switching time	see Fig.4	-	10	-	ns
$I_{\text{IFS}}$	input current on fast switching control (pin 13)	$V_1 = 0.4 \text{ V}$ $V_1 = 1 \text{ V}$	-	0.7 0.5	-	$\mu\text{A}$ $\mu\text{A}$
<b>Chrominance channel (CIN, COU)</b>						
$R_i$	internal input resistance		-	50	-	$\text{k}\Omega$
$V_O$	DC output level	$I_i = 0$	-	5	-	V
$G_A$	gain of amplifier A	$f = 1 \text{ MHz}$ $V_{\text{SW1}} = V_{\text{SW2}} = 2.0 \text{ V}$	-1	0	+1	dB
		$V_{\text{SW2}} = 0.8 \text{ V}$	+5	+6	+7	dB
$ \Delta G $	maximum gain variation	$100 \text{ kHz} < f < 8 \text{ MHz}$	-	3	-	dB
$\alpha_{\text{off}}$	isolation (off state)	$V_{\text{SW1}} = V_{\text{SW2}} = 0.8 \text{ V}$ $f = 5 \text{ MHz}$	-	60	-	dB
$Z_i$	output impedance	$V_{\text{SW1}} = V_{\text{SW2}} = 0.8 \text{ V}$	100	-	-	$\text{k}\Omega$
$R_o$	output resistance		-	7	-	$\Omega$
<b>TTL inputs (SW1, SW2, CLI)</b>						
$I_{\text{IH}}$	HIGH level input current	$V_{\text{IH}} = 2 \text{ V}$	-	-	10	$\mu\text{A}$
$I_{\text{IL}}$	LOW level input current	$V_{\text{IL}} = 0.8 \text{ V}$	-	-	600	$\mu\text{A}$
<b>Clamp output (CLO)</b>						
$V_{\text{OL}}$	LOW level output voltage	$I_{\text{OL}} = 2 \text{ mA}$	-	-	0.4	V
$V_{\text{OH}}$	HIGH level output voltage	$I_{\text{OH}} = 10 \mu\text{A}$	2.4	-	-	V
<b>Synchronization channel (SOUT)</b>						
$V_{\text{O(p-p)}}$	output amplitude		0.2	-	1.5	V

**Notes to the characteristics**

1. Supply voltage rejection ratio:  $20 \log V_{\text{R(CC)}}/V_{\text{R(O)}}$
2. The relative gain difference is measured when only one input signal (R, G, or B) is present.
3. The inputs RIN, GIN and BIN are interconnected;  $\Delta t$  is the maximum time coincidence error between the luminance and chrominance signals.

Fast RGB/YC switch for digital decoding

TDA8446; TDA8446T

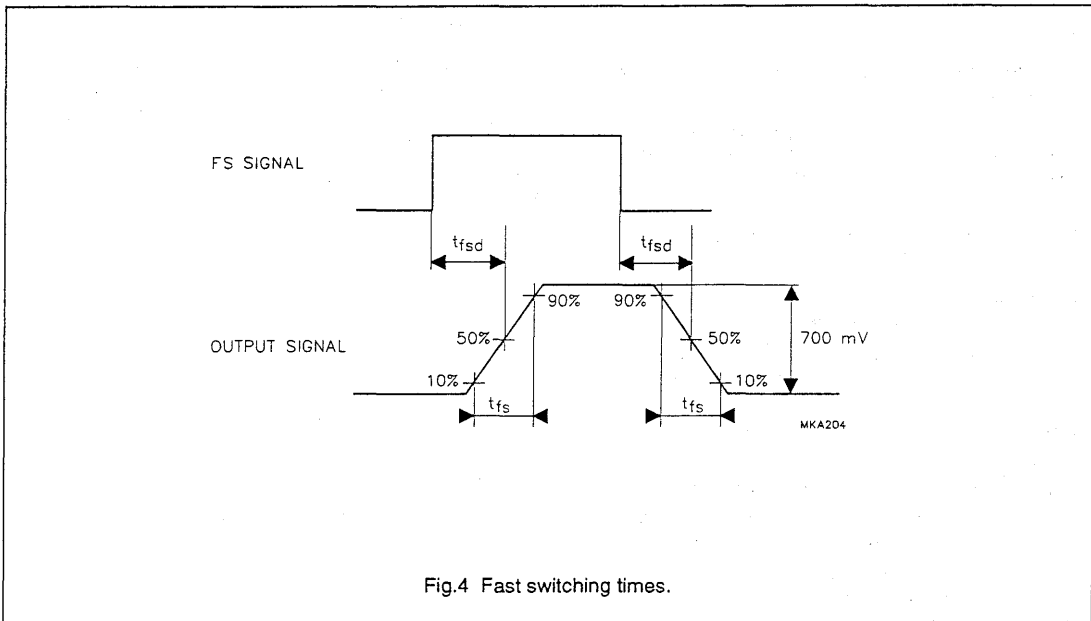

APPLICATION INFORMATION

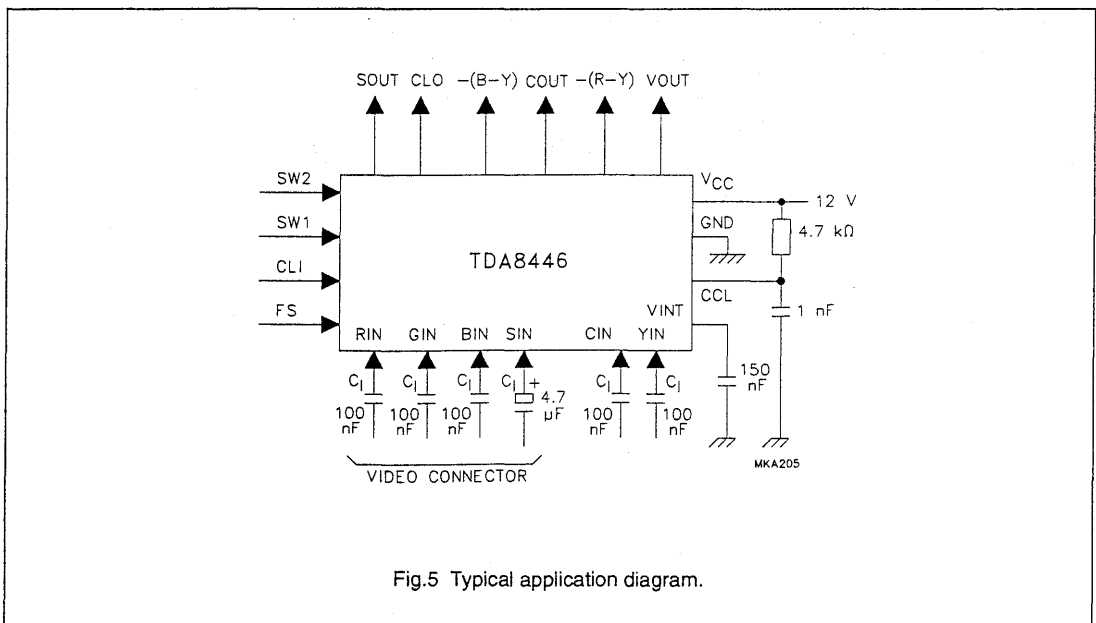

**PAL/NTSC encoder****TDA8501****FEATURES**

- Two input stages: R, G, B and  $-(R-Y)$ ,  $-(B-Y)$ , Y with multiplexing
- Chrominance processing, highly integrated, includes low frequency filters for the colour difference signals, and after the modulator a bandpass filter
- Fully controlled modulator produces a signal according to the PAL or NTSC standard without adjustments
- A free running oscillator. Can be tuned by crystal or by an external frequency source
- Output stages with separated Y + SYNC and chrominance (Y + C, SVHS), and a CVBS output. Signal amplitudes are correct for 75  $\Omega$  driving via an external emitter follower. Internal generation of NTSC setup
- Sync separator circuit and pulse shaper, to generate the required pulses for the processing, clamping, blanking, FH/2, and burst pulse
- H/2 control pin. In PAL mode the internally generated H/2 is connected to this pin and the phase of this signal can be reset
- Internal bandgap reference.

**GENERAL DESCRIPTION**

The TDA8501 is a highly integrated PAL/NTSC encoder IC which is designed for use in all applications where R, G and B or Y, U and V signals require transformation to PAL or NTSC values. the specification of the input signals are fully compatible with the specification of those of the TDA8505 SECAM-encoder.

**ORDERING INFORMATION**

EXTENDED TYPE NUMBER	PACKAGE			
	PINS	PIN POSITION	MATERIAL	CODE
TDA8501	24	DIL	plastic	SOT234AH2
TDA8501T	24	SO	plastic	SOT137AH1

PAL/NTSC encoder

TDA8501

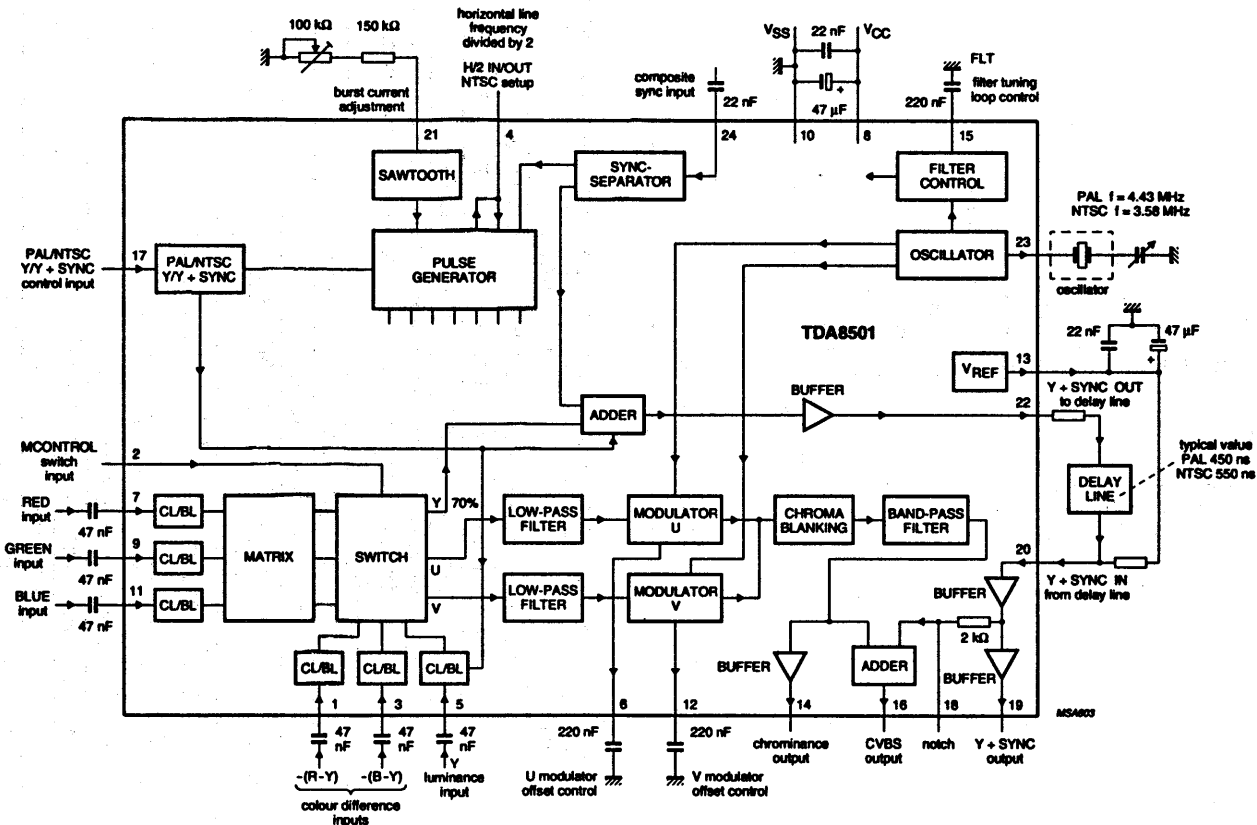

Fig.1 Block diagram.

## PAL/NTSC encoder

TDA8501

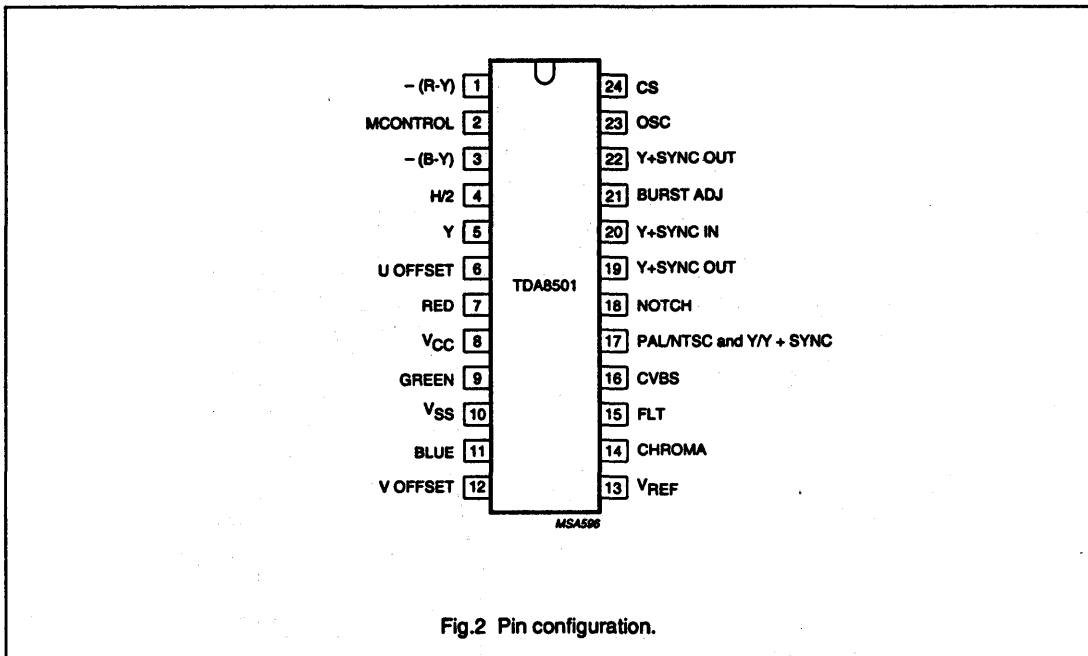

Fig.2 Pin configuration.

## PINNING

U and V respectively, are the terms used to describe the colour difference signals at the output of the matrix.

SYMBOL	PIN	DESCRIPTION
-(R-Y)	1	colour difference input signal, for EBU bar (75%) 1.05 V (p-p)
MCONTROL	2	multiplexer switch control input; HIGH = RGB, LOW = -(R-Y), -(B-Y), Y
-(B-Y)	3	colour difference input signal, for EBU bar (75%) 1.33 V (p-p)
H/2	4	line pulse input/output divided-by-2 for synchronizing the internal H/2, if not used, this pin dependent on mode selected, is either left open-circuit, or connected to V <sub>CC</sub> or to ground (note 1)
Y	5	luminance input signal 1 V nominal without sync
U OFFSET	6	U modulator offset control capacitor
R	7	RED input signal for EBU bar of 75% 0.7 V (p-p)
V <sub>CC</sub>	8	supply voltage; 5 V nominal
G	9	GREEN input signal for EBU bar of 75% 0.7 V (p-p)
V <sub>SS</sub>	10	ground (0 V)
B	11	BLUE input signal for EBU bar of 75% 0.7 V (p-p)
V OFFSET	12	V modulator offset control capacitor
V <sub>REF</sub>	13	2.5 V internal reference voltage output
CHROMA	14	chrominance output
FLT	15	filter tuning loop capacitor



## PAL/NTSC encoder

TDA8501

SYMBOL	PIN	DESCRIPTION
CVBS	16	composite PAL or NTSC output, 2 V (p-p) nominal
PAL/NTSC and Y/Y + SYNC	17	four level control pin (note 2)
NOTCH	18	Y + SYNC output via an internal resistor of 2 k $\Omega$ ; a notch filter can be connected to this pin
Y + SYNC OUT	19	2 V (p-p) nominal Y + SYNC output
Y + SYNC IN	20	Y + SYNC input; (from pin 22) connected to the output of the external delay line
BURST ADJ	21	burst current adjustment via external resistor
Y + SYNC OUT	22	Y + SYNC output 1 V (p-p) nominal, connected to the input of the external delay line
OSC	23	oscillator tuning: connected to either a crystal in series with capacitor to ground, or to an external frequency source via a resistor in series with a capacitor
CS	24	composite sync input, 0.3 V (p-p) nominal

**Notes**

- Pin 4: in PAL mode, if not connected to external H2 pulse, this pin is the output for the internally generated H/2 signal.  
Pin 4: in NTSC mode, for internal set-up this pin is connected to ground; when internal set-up is switched off, this pin is connected to  $V_{CC}$ .
- The listed voltages connected to pin 17 (if  $V_{CC} = +5$  V) enable the following Y (via pin 5) input signal states:  
0 V = PAL mode; at pin 5, Y without sync and input blanking on  
5 V = NTSC mode; at pin 5, Y without sync and input blanking on  
1.8 V = PAL mode; at pin 5, Y with sync and input blanking off  
3.2 V = NTSC mode; at pin 5, Y with sync and input blanking off

## PAL/NTSC encoder

TDA8501

**FUNCTIONAL DESCRIPTION**

The TDA8501 device comprises:

- encoder circuit
- oscillator and filter control
- sync separator and pulse shaper.

Within this functional description, the term Y is used to describe the luminance signal and the terms U and V respectively, are used to describe the colour difference signals.

**Encoder circuit****INPUT STAGE**

The input stage of the device uses two signal paths (see Fig.1). Fast switching between the two signal paths is achieved by means of the signal path selection switch MCONTROL (pin 2).

**R, B AND G INPUT SIGNALS PATH**

One signal path provides the connection for R, G and B signal inputs (via pins 7, 9 and 11) which are connected to a matrix via clamping and line blanking circuits. The signal outputs from the matrix are U, V and Y.

For an EBU colour bar of 75% the amplitude of the signal must be 0.7 V (peak-to-peak):

$$U = 0.493 (B-Y)$$

$$V = 0.877 (R-Y)$$

$$Y = 0.299 R + 0.587 G + 0.114 B$$

When selected (via MCONTROL), the U, V signals from the matrix are routed through the selection switch to the low pass filters. The Y signal from the matrix is routed through the selection switch to the adder and combined with the sync pulse from the sync separator and then connected via a buffer internally to pin 22 (Y + SYNC OUT to delay line).

**-(R-Y), -(B-Y) AND Y INPUT SIGNALS PATH**

A second signal path provides the connection for negative colour difference signal inputs -(R-Y), -(B-Y) i.e. V, U (via pins 1, 3) and luminance Y (via pin 5), which are routed directly to the switch inputs via clamping and line blanking circuits.

The Y input signal (via pin 5) differs from other signal inputs, in that the timing of the internal clamp is after the sync period.

The amplitude and polarity of these colour difference and luminance input signals are processed to provide suitable switch inputs of U, V and Y signal values.

The condition for 75% colour bar is:

$$\text{pin 1} \quad -(R-Y) = 1.05 \text{ V (peak-to-peak)}$$

$$\text{pin 3} \quad -(B-Y) = 1.33 \text{ V (peak-to-peak)}$$

$$\text{pin 5} \quad Y = 1 \text{ V (peak-to-peak) without sync}$$

When selected (via MCONTROL), the U and V signals (via the switch) are routed to the low pass filters. The Y signal (via the switch) is routed via the adder and buffer to pin 22 (Y + SYNC OUT to delay line). Dependent on pin 17 conditioning, the Y signal may have external or internal sync added (see section Four level control pin).

**FOUR LEVEL CONTROL PIN**

The Y input signal (via pin 5) is conditioned by use of the 4-level control pin (pin 17) to emulate either the PAL or NTSC modes, with sync and input blanking off or without sync and input blanking on.

Pin 17 may be hard wire connected to either ground (LOW for PAL mode) or  $V_{CC}$  (HIGH for NTSC mode). External resistors can further modify the voltage level input at pin 17 to condition (pin 5) Y with sync and input blanking off or Y without sync and input blanking on. (see section PAL/NTSC and Y/Y + SYNC).

**U AND V SIGNALS**

In PAL and NTSC modes the U and V (colour difference) signals at the output of the switch are configured differently as follows:

**PAL mode:**

- after the adding of the burst pulse to U and V, these signals are connected to the input of the low pass filters. During the vertical sync period the burst pulse is suppressed.

**NTSC mode:**

- the burst pulse is only added to U and the gain of the U and V signals is 0.95 of the gain in PAL mode. During the vertical sync period the burst pulse is suppressed.

**LOW PASS FILTERS**

The -3dB nominal frequency response level of the low pass filters are different in PAL and NTSC modes.

## PAL/NTSC encoder

## TDA8501

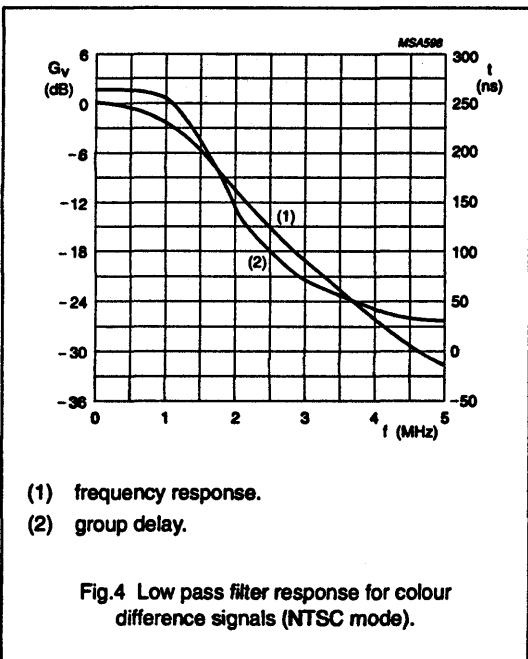
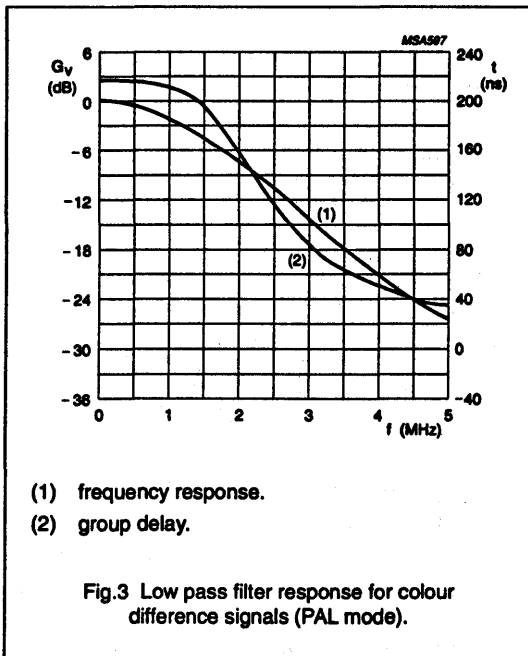

PAL mode: bandwidth = 1.35 MHz nominal (see Fig.3).

NTSC mode: bandwidth = 1.1 MHz nominal (see Fig.4).

The signal outputs of the low pass filters are connected to the signal inputs of the U and V modulators.

#### U AND V MODULATORS

Two four-quadrant multipliers are used for quadrature amplitude modulation of the U and V signals. The level of harmonics produced by the modulated signals are minimal, because of real multiplication with sinewave carriers.

The unbalance of the modulators is minimized by means of a control loop and two external capacitors, pin 6 for the U modulator and pin 12 for the V modulator. The timing of the control loop is triggered by the H/2 pulse, so that during one sync period the U control is active and during the next sync period the V control is active. In this way, when U and V are both zero, the suppressed carrier is guaranteed to be at a low level.

The internal oscillator circuit generates two sinewave carriers (0 degree and 90 degree). The '0 degree' (0) carrier is connected to the U modulator and the '90 degree' (1) carrier is connected to the V modulator.

#### PAL mode:

- switched sequentially by the H/2 pulse, the V signal is modulated alternately with the direct and inverse carrier.
- the internal H/2 pulse can be forced into a specific phase by means of an external pulse connected to pin 4 (H/2). Forcing is active at HIGH level. If not used pin 4 can be left open-circuit or connected to ground. If pin 4 is left open, the internally generated H/2 pulse (output) is connected to this pin.

#### NTSC mode:

- alternation of the V modulation is not allowed. If pin 4 is not used for set-up control (see Y + SYNC, CVBS and Chrominance outputs), it can be left open-circuit or connected to ground.

#### CHROMINANCE BLANKING

The signal outputs from the modulators are connected to the signal input of the chrominance blanking circuit. To avoid signal distortion that may be caused by the control loop, the signal outputs of the modulators are blanked during the sync period. This prevents signal distortion during the adding of the sync pulse at the CVBS output circuit.

PAL/NTSC encoder

TDA8501

**BANDPASS FILTER**

A wide symmetrical bandpass filter is used so that a maximum performance of the chrominance for Y + C (SVHS) is guaranteed. This wide curve is possible because of the minimal signal level of the harmonics within the modulators see Figs (PAL mode: 5 and 6); (NTSC mode: 7 and 8) which illustrate the nominal response for PAL and NTSC modes.

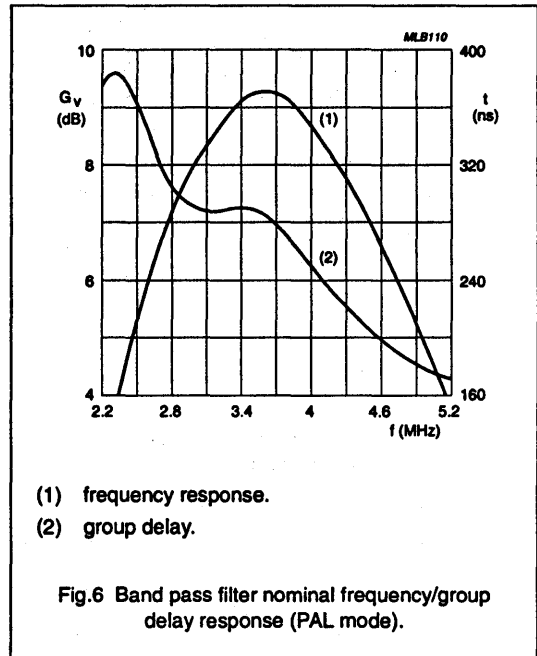
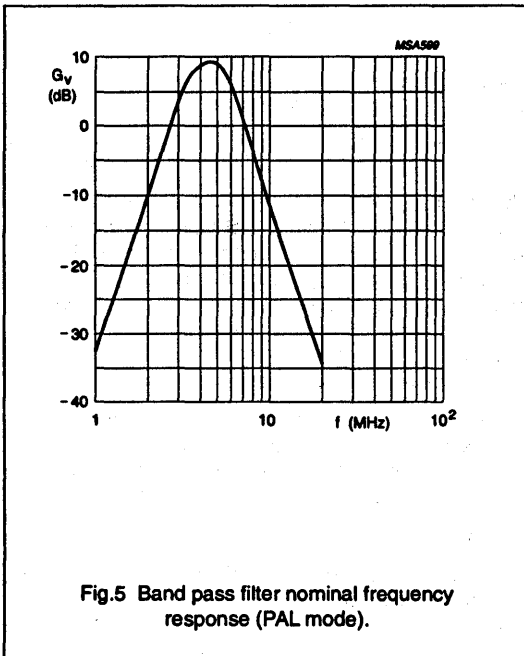

PAL/NTSC encoder

TDA8501

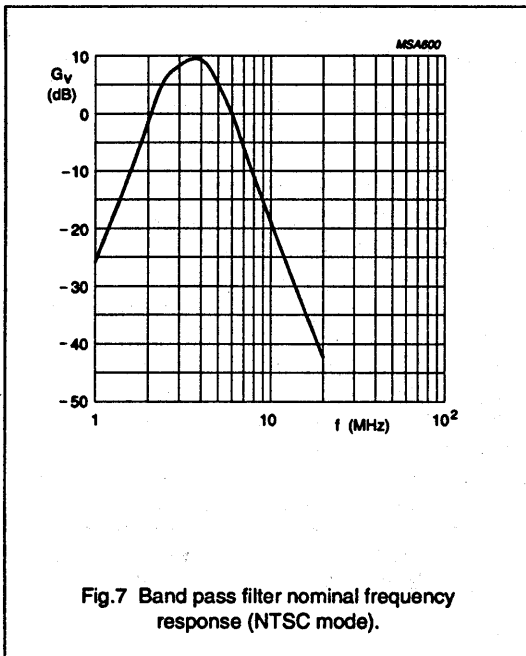
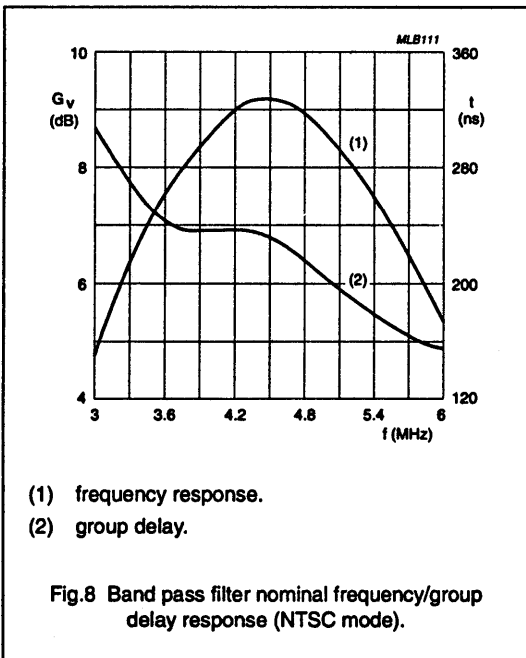

Fig.7 Band pass filter nominal frequency response (NTSC mode).



- (1) frequency response.
- (2) group delay.

Fig.8 Band pass filter nominal frequency/group delay response (NTSC mode).

Y + SYNC, CVBS AND CHROMINANCE OUTPUTS

The Y signal from the matrix, or the Y signal from pin 5, (selected via the switch) is added with the composite sync signal of the sync separator (dependent on pin 17 conditioning). The output of the adder, nominal 1 V (peak-to-peak), is connected to pin 22 (see Fig.1). Pin 22 is connected to an external delay line.

The delay line is necessary for correct timing of the Y + SYNC signal with the chrominance signal. The output resistor of the delay line is connected to  $V_{REF}$  (pin 13). The output of the external delay line is connected to (input) pin 20.

The Y + SYNC (delayed) input signal at pin 20 is amplified via a buffer to a level of 2 V (peak-to-peak) nominal and connected to pin 19 (Y + SYNC output).

The Y + SYNC (delayed) input signal at pin 20 is also connected via an internal resistor of 2 k $\Omega$  to the input of the CVBS adder stage. After the internal resistor of 2 k $\Omega$ , and before the input of the CVBS adder, an external notch filter can be connected via pin 18.

The chrominance output of the bandpass filter is added with Y + SYNC signal via the CVBS adder. The CVBS (combined video and blanking signal) output of the adder is connected to pin 16 with a nominal amplitude of 2 V (peak-to-peak).

The chrominance output of the bandpass filter is amplified via a buffer and connected to pin 14. The chrominance amplitude corresponds with the value of Y + SYNC signal output at pin 19. Together both outputs give the Y + C (SVHS) signals.

BLACK AND BLANKING LEVELS IN PAL AND NTSC MODES

PAL mode: Fig.9 illustrates the nominal Y + SYNC signal at pin 22, the difference between black and blanking level is 0 mV.

NTSC mode: Fig.10 illustrates the nominal Y + SYNC signal at pin 22, the difference between black and blanking level is 53 mV.

Because of the difference between the black and blanking level in the NTSC mode, there are two options for NTSC.

## PAL/NTSC encoder

TDA8501

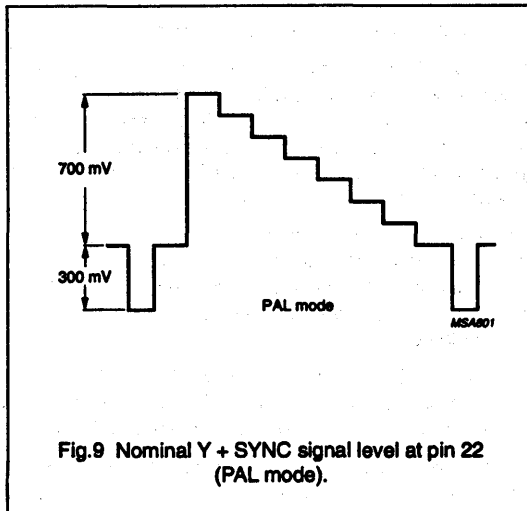

Fig.9 Nominal Y + SYNC signal level at pin 22 (PAL mode).

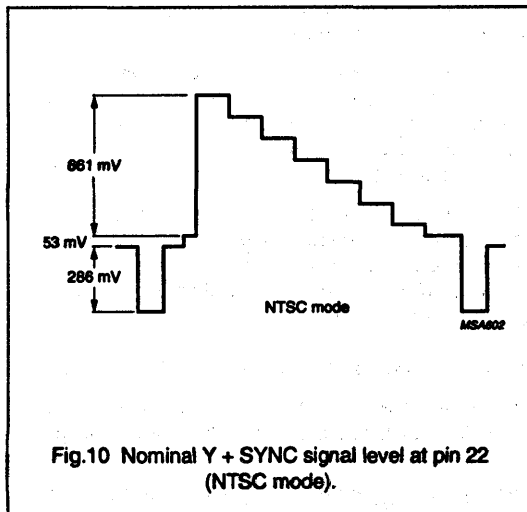

Fig.10 Nominal Y + SYNC signal level at pin 22 (NTSC mode).

*NTSC option with internal set-up generation*

Pin 4 connected to ground or left open-circuit. The set-up is generated internally and the input signals have the values already specified in section Input stage. The set-up is not suppressed during vertical sync.

*NTSC option without internal set-up generation*

Pin 4 connected to  $V_{CC}$ . This option places some restrictions on the input signals as follows:

- if the output signal must be according to the NTSC standard, the input signals must be generated with a specific set-up level
- for R, G and B inputs a set-up level of 53 mV is required, therefore the specified amplitude must be 753 mV (peak-to-peak) instead of 700 mV (peak-to-peak)
- for U, V and Y inputs a set-up level for Y of 76 mV is required, therefore the specified amplitude must be 1076 mV (peak-to-peak) (without sync) instead of 1 V (peak-to-peak). This option, combined with U, V and Y inputs, is not possible if  $V_{CC}$  is  $< 4.75$  V.

## PAL/NTSC encoder

## TDA8501

**Oscillator and Filter Control**

The internal crystal oscillator is connected to pin 23 which provides for the external connection of a crystal in series with a trimmer to ground. It is possible to connect an external signal source to pin 23, via a capacitor in series with a resistor. The signal shape is not important. Figure 11 shows the external components connected to pin 23 and the required conditions. The minimum AC current of  $50 \mu\text{A}$  must be determined by the resistors ( $R_{\text{int}}$  and  $R_{\text{ext}}$ ) and the voltage of the signal source. For example, in this way an external sub-carrier, locked to the sync, can be used.

PAL mode: frequency of the oscillator is 4.433618 MHz.

NTSC mode: frequency of the oscillator is 3.579545 MHz.

The  $-3 \text{ dB}$  of the low pass filters and the centre frequency of the bandpass filter are controlled by the filter control loop and directly coupled to the value of the frequency of the oscillator. The external capacitor of the control loop is connected to pin 15.

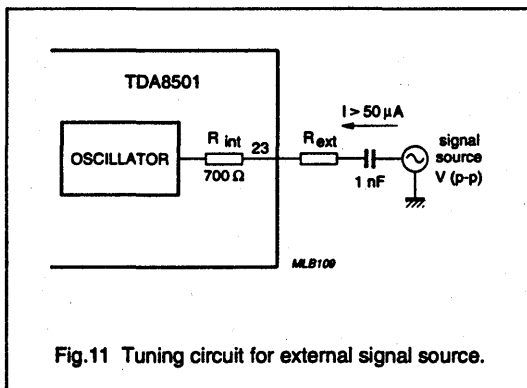

Fig.11 Tuning circuit for external signal source.

**Sync separator and Pulse shaper**

The composite sync (CS) input at pin 24 (via the sync separator) together with a sawtooth generator provide the source for all pulses necessary for the processing.

Pulses are used for:

- clamping
- video blanking
- H/2
- chrominance blanking
- burst pulse generation for adding to U, V
- pulses for the modulator offset control.

The value of the sawtooth generator output (current) is determined by the value of a fixed resistor to ground which is connected externally at pin 21 (BURST ADJ). When finer tolerance of the burst position is required, the fixed resistor is connected in series with a variable potentiometer to ground. By use of the potentiometer the burst position at the outputs can be finely adjusted, after which the pulse width of the burst and the position and pulse width of all other internal pulses are then determined. When using a fixed resistor with a tolerance of 2%, a tolerance of 10% of the burst position can be expected. Timing diagrams of the pulses are provided by Figs 12 and 13.

H/2 at pin 4 is only necessary in the PAL mode when the internal H/2 pulse requires locking with an external H/2 phase (two or more encoders locked in same phase). The forcing of the internal H/2 to a desired phase is possible by means of an external pulse. Forcing is active at HIGH level.

For the functioning of Pin 4 in the NTSC mode see also section Black and Blanking levels in PAL and NTSC modes.

PAL/NTSC encoder

TDA8501

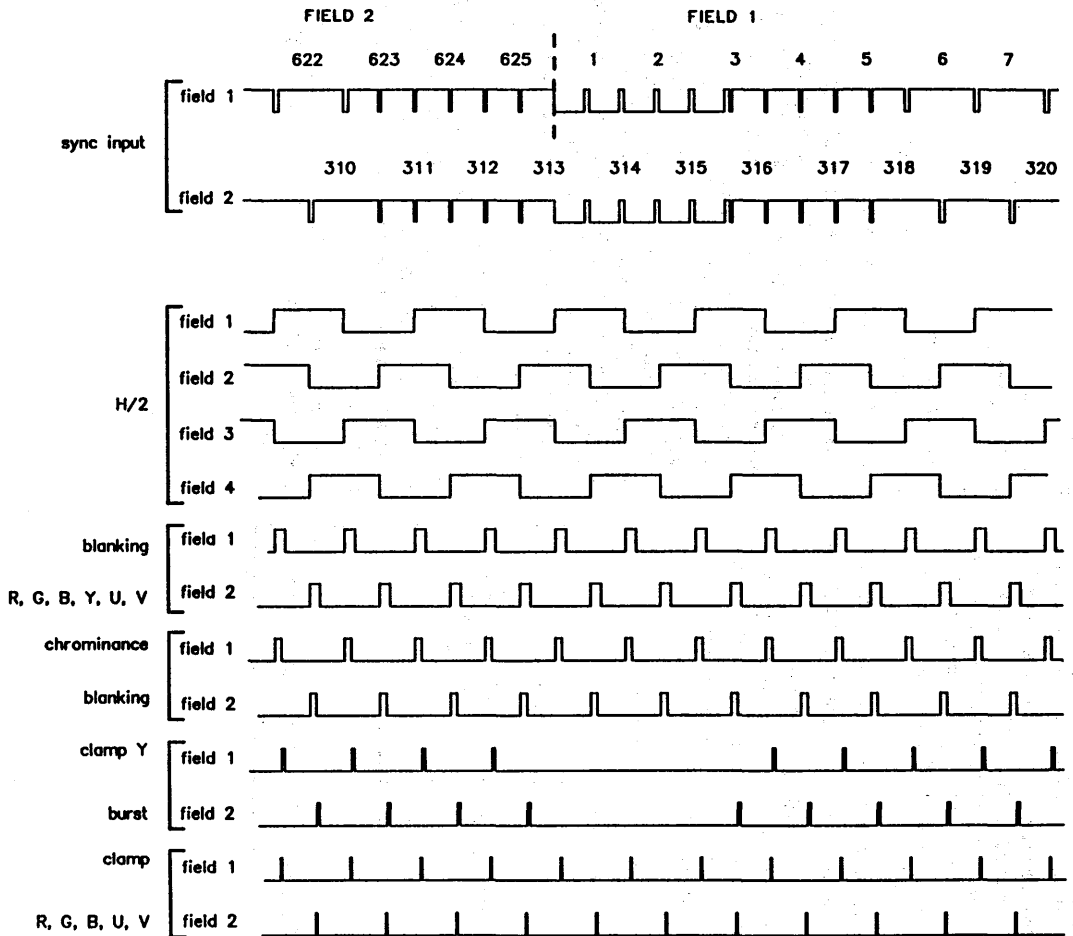

MKA438

Fig.12 Sync separator and pulse shaper pulses.



PAL/NTSC encoder

TDA8501

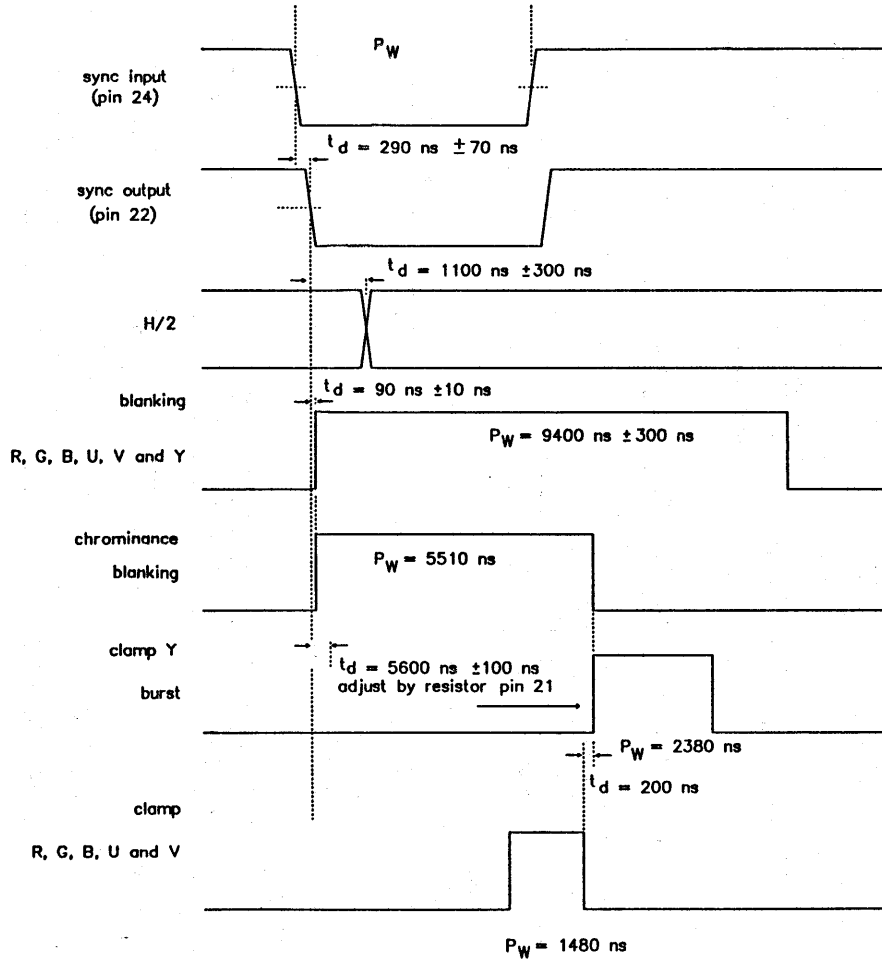

MKA439

Fig.13 Sync separator and pulse shaper pulse timing levels.

## PAL/NTSC encoder

TDA8501

## PAL/NTSC and Y/Y + SYNC

Pin 17 is used as a four level control pin to condition the Y/Y + SYNC input signal (via pin 5). Pin 17 is normally connected to ground for PAL mode, or to  $V_{CC}$  for the NTSC mode. By use of external resistors (potential divider connected to pin 17), the input blanking at pin 5 can be switched on and off. (see Table 1 and Fig 14).

Table 1 PAL/NTSC Y/Y + SYNC pin 5 options (pin 17 connection configurations).

MODE	PIN 5 STATUS	PIN 17 CONNECTION REQUIREMENT
PAL	Y without sync and input blanking on	pin 17 LOW, connected to $V_{SS}$
NTSC	Y without sync and input blanking on	pin 17 HIGH, connected to $V_{CC}$
PAL	Y with sync and input blanking off	pin 17 with 39 k $\Omega$ connected to $V_{CC}$ and 22 k $\Omega$ connected to $V_{SS}$
NTSC	Y with sync and input blanking off	pin 17 with 22 k $\Omega$ connected to $V_{CC}$ and 39 k $\Omega$ connected to $V_{SS}$

## LIMITING VALUES

In accordance with the Absolute Maximum System (IEC134); all voltages referenced to  $V_{SS}$  (pin 10).

SYMBOL	PARAMETER	MIN.	MAX.	UNIT
$V_{CC}$	positive supply voltage	0	5.5	V
$T_{stg}$	storage temperature	-65	+150	$^{\circ}\text{C}$
$T_{amb}$	operating ambient temperature	-25	+70	$^{\circ}\text{C}$

## THERMAL RESISTANCE

SYMBOL	PARAMETER	THERMAL RESISTANCE
$R_{th\ ja}$	from junction to ambient in free air SOT234 SOT137	66 K/W 75 K/W

## DC CHARACTERISTICS

$V_{CC} = 5\text{ V}$ ;  $T_{amb} = 25\text{ }^{\circ}\text{C}$ ; all voltages referenced to ground (pin 10); unless otherwise specified.

SYMBOL	PARAMETER	CONDITIONS	MIN.	TYP.	MAX.	UNIT
<b>Supply (pin 8)</b>						
$V_{CC}$	supply voltage		4.5	5.0	5.5	V
$I_{CC}$	supply current		-	40	-	mA
$P_{tot}$	total power dissipation		-	200	-	mW
$V_{REF}$	reference voltage output (pin 13)		2.425	2.5	2.575	V

## PAL/NTSC encoder

TDA8501

## AC CHARACTERISTICS

 $V_{CC} = 5\text{ V}$ ;  $T_{amb} = 25\text{ }^{\circ}\text{C}$ ; composite sync signal connected to pin 24; unless otherwise specified.

SYMBOL	PARAMETER	CONDITIONS	MIN.	TYP.	MAX.	UNIT
<b>Encoder circuit</b>						
Input stage (pins 1, 3, 5, 7, 9 and 11); black level = clamping level						
$V_{n(max)}$	maximum signal from black level positive		-	1.2	-	V
$V_{n(min)}$	from black level negative	only pins 1, 3 and 5	-	0.9	-	V
$I_{bias}$	input bias current	$V_i = V_{13}$	-	-	< 1	$\mu\text{A}$
$V_i$	input voltage clamped	input capacitor connected to ground	tof	$V_{13}$	tof	V
$ Z_i $	input clamping impedance					
		$I_i = 1\text{ mA}$	-	80	-	$\Omega$
		$I_o = 1\text{ mA}$	-	80	-	$\Omega$
	matrix and gain tolerance of R, G and B signals		-	-	< 5	%
G	gain tolerance of Y, -(R-Y) and -(B-Y)		-	-	< 5	%
<b>MCONTROL (pin 2; note 1)</b>						
$V_L$	LOW level input voltage Y, -(R-Y) and -(B-Y)		0	-	0.4	V
$V_H$	HIGH level input voltage R, G and B		1	-	5	V
$I_i$	input current		-	-	-3	$\mu\text{A}$
$t_{sw}$	switching time		-	50	-	ns
<b>U modulator offset control (pin 6)</b>						
$V_6$	DC voltage control level		-	2.5	-	V
$I_{L1}$	input leakage current		-	-	100	nA
$V_{LL}$	limited level voltage LOW		-	1.8	-	V
$V_{HL}$	limited level voltage HIGH		-	3.2	-	V
<b>V modulator offset control (pin 12)</b>						
$V_{12}$	DC voltage control level		-	2.5	-	V
$I_{L1}$	input leakage current		-	-	100	nA
$V_{LL}$	limited level voltage LOW		-	1.8	-	V
$V_{HL}$	limited level voltage HIGH		-	3.2	-	V
<b>Y + SYNC (pin 22 out to delay circuit)</b>						
$R_O$	output resistance		-	-	< 25	$\Omega$
$I_{sink}$	maximum sink current		350	-	-	$\mu\text{A}$
$I_{source}$	maximum source current		1000	-	-	$\mu\text{A}$
$V_{BL}$	black level output voltage		-	2.5	-	V

## PAL/NTSC encoder

## TDA8501

SYMBOL	PARAMETER	CONDITIONS	MIN.	TYP.	MAX.	UNIT
PAL mode; pin 17 = 0 V						
$V_{\text{SYNC}}$	sync voltage amplitude		285	300	315	mV
$V_Y$	Y voltage amplitude		665	700	735	mV
$V_{\text{DF}}$	difference between black and blanking level		–	0	–	mV
NTSC mode; pin 17 = 5 V and pin 4 open-circuit or ground						
$V_{\text{SYNC}}$	sync voltage amplitude		270	286	300	mV
$V_Y$	Y voltage amplitude		628	661	694	mV
$V_{\text{DF}}$	difference between black and blanking level		–	53	–	mV
BW	frequency response	pin 22 with external load of $R = 10 \text{ k}\Omega$ and $C = 10 \text{ pF}$	10	–	–	MHz
	group delay tolerance		–	–	20	ns
$t_d$	sync delay from pin 24 to pin 22		220	290	360	ns
$t_d$	Y delay from pin 5 to pin 22		–	10	–	ns
$\alpha$	Chrominance cross talk	0 dB = 1330 mV (peak-to-peak) = 75% RED	–	–	–60	dB
Y + SYNC IN (pin 20 from delay circuit; note 2)						
$I_{\text{bias}}$	input bias current		–	–	1	$\mu\text{A}$
$V_i$	maximum voltage amplitude		–	–	1	V
Y + SYNC OUT (pin 19 output Y (SVHS); note 2)						
$R_o$	output resistance		–	120	–	$\omega$
$I_{\text{sink}}$	maximum sink current		650	–	–	$\mu\text{A}$
$I_{\text{source}}$	maximum source current		1000	–	–	$\mu\text{A}$
$V_{\text{BL}}$	black level output voltage		–	1.65	–	V
G	Y + SYNC gain; from pin 20 to pin 19		–	12	–	dB
BW	frequency response	pin 19 with external load of $R = 10 \text{ k}\Omega$ and $C = 10 \text{ pF}$	10	–	–	MHz
	group delay tolerance		–	–	20	ns
$\alpha$	Chrominance cross talk	0 dB = 1330 mV (peak-to-peak) = 75% RED	–	–	–54	dB

## Notes

1. The threshold level of this pin is 700 mV  $\pm$ 20 mV. The specification of the HIGH and LOW levels is according to the SCART fast blanking.
2. Pin 20 condition: black level of input signal must be 2.5 V; amplitude 0.5 V (peak-to-peak) nominal.

## PAL/NTSC encoder

TDA8501

## AC CHARACTERISTICS (continued)

SYMBOL	PARAMETER	CONDITIONS	MIN.	TYP.	MAX.	UNIT
<b>NOTCH (pin 18)</b>						
$R_o$	output resistance		1750	2000	2500	$\Omega$
$V_{CC}$	DC voltage level		-	2.5	-	V
$I_{sink}$	maximum sink current		350	-	-	$\mu A$
<b>Chrominance output (pin 14)</b>						
$I_{sink}$	maximum sink current		700	-	-	$\mu A$
$I_{source}$	maximum source current		1000	-	-	$\mu A$
$R_o$	output resistance		-	120	-	$\Omega$
$\Delta V_{DC}$	variation of DC voltage level when chrominance signal is blanked and chrominance signal is not blanked		-	-	5	mV
<b>PAL mode; pin 17 = 0 V</b>						
$V_o$	chrominance output voltage (peak-to-peak) amplitude burst ratio: chrominance (75% RED)/burst		480 2.1	600 2.2	720 2.3	mV
<b>NTSC mode; pin 17 = 5 V</b>						
$V_o$	chrominance output voltage (peak-to-peak) amplitude burst ratio: chrominance (75% RED)/burst		460 2.1	570 2.2	680 2.3	mV
	carrier suppression when input-signals are 0 V	0 dB = 1330 mV (peak-to-peak)	-	37	-	dB
	phase accuracy (difference between 0 and 90 degree carriers)		-	-	2	degrees
LPF	Low-pass filters	see Figs 3 and 4				
BPF	Band-pass filters	see Figs 5 and 6				
$V_n$	noise level (RMS value)		-	-	4	mV
BP	burst phase; 0 degrees = phase U carrier					
	PAL mode		-	$\pm 135$	-	degrees
	NTSC mode		-	180	-	degrees
$\alpha$	Y + SYNC cross talk (0 to 6 MHz)	0 dB = 1400 mV (peak-to-peak)	-	-	-60	dB

## PAL/NTSC encoder

TDA8501

SYMBOL	PARAMETER	CONDITIONS	MIN.	TYP.	MAX.	UNIT
<b>CVBS output (pin 16)</b>						
$I_{\text{sink}}$	maximum sink current		650	–	–	$\mu\text{A}$
$I_{\text{source}}$	maximum source current		1000	–	–	$\mu\text{A}$
$V_{\text{O}}$	DC voltage level	$Y + \text{SYNC} = 0$	–	1.6	–	V
G	Y + SYNC gain; from pin 20 to pin 16		–	12	–	dB
G	chrominance difference; from pin 14 to pin 16		–	0	–	dB
$G_{\text{e}}$	differential phase	note 1	–	–	3	degrees
$G_{\text{v}}$	differential gain	note 2	–	–	3	dB
$R_{\text{O}}$	output resistance		–	120	–	$\Omega$
<b>Oscillator output (pin 23)</b>						
OSC	series-resonance	the resonance resistance of the crystal should be $< 60 \Omega$ and the parallel capacitance of the crystal should be $< 10 \text{ pF}$ .				
<b>Filter tuning loop (pin 15)</b>						
$V_{\text{DC}}$	DC control voltage level NTSC		–	0.83	–	V
$V_{\text{DC}}$	DC control voltage level PAL		–	0.88	–	V
$V_{\text{DCL}}$	limited DC-level LOW	$I_{\text{O}} = 200 \mu\text{A}$	–	0.27	–	V
$V_{\text{DCH}}$	limited DC-level HIGH	$I_{\text{I}} = 200 \mu\text{A}$	–	1.8	–	V
<b>H2 (pin 4)</b>						
$V_{\text{L}}$	LOW level input voltage	inactive	0	–	1	V
$V_{\text{H}}$	HIGH level input voltage	active	4	–	5	V
$I_{\text{I}}$	current for forcing HIGH		220	–	–	$\mu\text{A}$
$I_{\text{O}}$	current for forcing LOW		260	–	–	$\mu\text{A}$
$V_{\text{O}}$	voltage out LOW		–	–	$< 0.5$	V
$V_{\text{O}}$	voltage out HIGH		4	–	–	V
$I_{\text{sink}}$	maximum sink current		50	–	–	$\mu\text{A}$
$I_{\text{source}}$	maximum source current		50	–	–	$\mu\text{A}$
<b>Composite sync input (pin 24)</b>						
$V_{\text{SYNC}}$	SYNC pulse amplitude		75	300	600	mV(p-p)
	slicing level		–	50	–	%
$I_{\text{I}}$	input current		–	4	–	$\mu\text{A}$
$I_{\text{O}}$	maximum output current during SYNC		–	100	–	$\mu\text{A}$
<b>BURST ADJ (pin 21; note 3)</b>						
BP	DC voltage level		–	$V_{\text{REF}}$ (V13)	–	V

## PAL/NTSC encoder

TDA8501

SYMBOL	PARAMETER	CONDITIONS	MIN.	TYP.	MAX.	UNIT
<b>Control pin PAL/NTSC and Y/Y + SYNC (pin 17; note 4)</b>						
V <sub>I</sub>	PAL mode and blanking pin 5 active internal sync added to Y		0	–	1	V
V <sub>I</sub>	PAL mode and blanking pin 5 inactive internal sync not added to Y		1.6	–	2.0	V
V <sub>I</sub>	NTSC mode and blanking pin 5 active internal sync added to Y		4	–	5	V
V <sub>I</sub>	NTSC mode and blanking pin 5 inactive internal sync not added to Y		3	–	3.4	V
I <sub>bias</sub>	input bias current		–	–	–10	μA

**Notes**

1. Definition: *maximum phase – minimum phase = difference phase*
2. Definition:  $\frac{\text{maximum gain} - \text{minimum gain}}{\text{maximum gain}} \times 100 = \text{difference gain \%}$
3. The output impedance of this pin is low (< 100 Ω). The nominal value of the external resistor is 196 kΩ (see also section Sync separator and Pulse shaper).
4. The threshold levels are: 0.25 times V<sub>CC</sub>, 0.5 times V<sub>CC</sub> and 0.75 times V<sub>CC</sub>.

PAL/NTSC encoder

TDA8501

Table 2 Internal circuitry.

PIN	NAME	CIRCUIT	DESCRIPTION
1	-(R-Y)		-(R-Y) input; connected via 47 nF capacitor 1.05 V (p-p) for EBU bar of 75% see also pins 3, 5, 7, 9 and 11
2	MCONTROL		multiplexer switch control input < 0.4 V Y, U and V > 1 V R, G and B
3	-(B-Y)	see pin 1	-(B-Y) input; connected via 47 nF capacitor 1.33 V (p-p) for EBU bar of 75%
4	H/2 IN/OUT		H/2 input PAL MODE: pin open, output of internal H/2 Forcing possibility NTSC mode: 0 V set-up 5 V no set-up



PAL/NTSC encoder

TDA8501

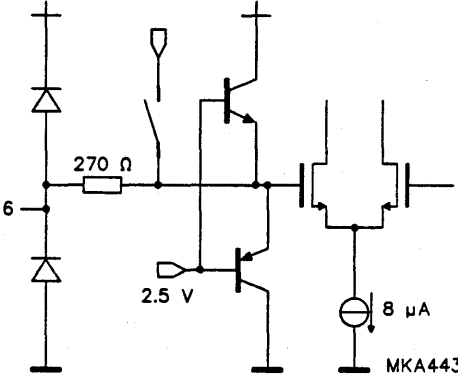
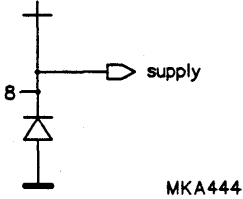
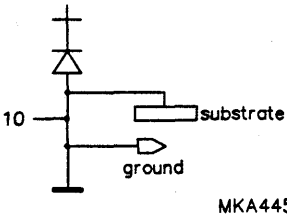
PIN	NAME	CIRCUIT	DESCRIPTION
5	Y	see pin 1	Y input; connected via 47 nF capacitor 1 V (p-p) for EBU bar of 75%
6	U OFFSET		220 nF (low-leakage) connected to ground see also pin 12
7	R	see pin 1	RED input; connected via 47 nF capacitor 0.7 V (p-p) for EBU bar of 75%
8	V <sub>CC</sub>		supply voltage 5 V nominal
9	G	see pin 1	GREEN input; connected via 47 nF capacitor 0.7 V (p-p) for EBU bar of 75%
10	V <sub>SS</sub>		ground
11	B	see pin 1	BLUE input; connected via 47 nF capacitor 0.7 V (p-p) for EBU bar of 75%

PAL/NTSC encoder

TDA8501

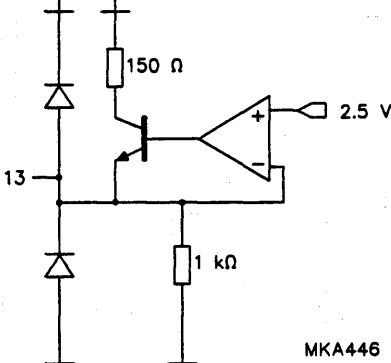
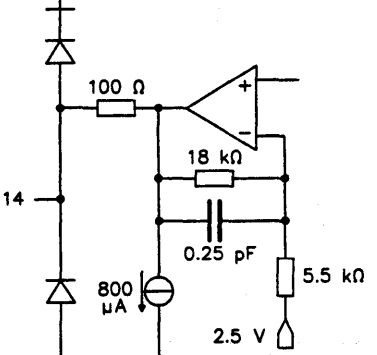
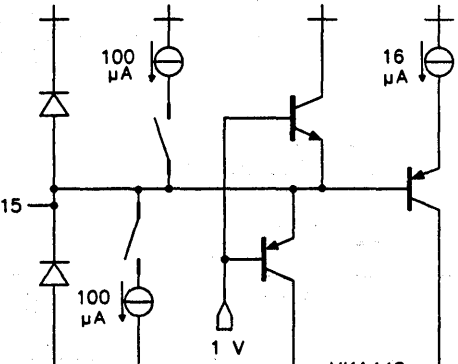
PIN	NAME	CIRCUIT	DESCRIPTION
12	V OFFSET	see pin 6	220 nF (low-leakage) connected to ground
13	V <sub>REF</sub>	 <p style="text-align: right;">MKA446</p>	2.5 V reference voltage decoupling with 47 μF and 22 nF capacitors
14	CHROMA	 <p style="text-align: right;">MKA447</p>	chrominance output; together with pin 19 the Y + C (SVHS) output
15	FLT	 <p style="text-align: right;">MKA448</p>	filter control pin 220 nF capacitor to ground

PAL/NTSC encoder

TDA8501

PIN	NAME	CIRCUIT	DESCRIPTION
16	CVBS	<p>MKA449</p>	CVBS output
17	PAL/NTSC Y/Y + SYNC	<p>MKA450</p>	4-level control pin Pin 5: 0 V PAL, Y 1.8 V PAL Y + SYNC 3.2 V NTSC Y + SYNC 5 V NTSC Y
18	NOTCH	<p>MKA451</p>	pin for external notch filter

PAL/NTSC encoder

TDA8501

PIN	NAME	CIRCUIT	DESCRIPTION
19	Y + SYNC OUT	<p>MKA452</p>	output of the Y + SYNC signal; together with pin 14 the Y + C (SVHS) output
20	Y + SYNC IN	<p>MKA453</p>	input of the delayed Y + SYNC signal of the delay line black level must be 2.5 V
21	BURST ADJ	<p>MKA454</p>	external resistor to ground for adjusting the position of the burst

PAL/NTSC encoder

TDA8501

PIN	NAME	CIRCUIT	DESCRIPTION
22	Y + SYNC OUT		output of the Y + SYNC signal, connected to the delay line via a resistor
23	OSC		subcarrier-crystal in series with a trimmer, or an external subcarrier signal, via 1 nF in series with a resistor
24	CS		composite SYNC signal input amplitude < 600 mV (p-p)

PAL/NTSC encoder

TDA8501

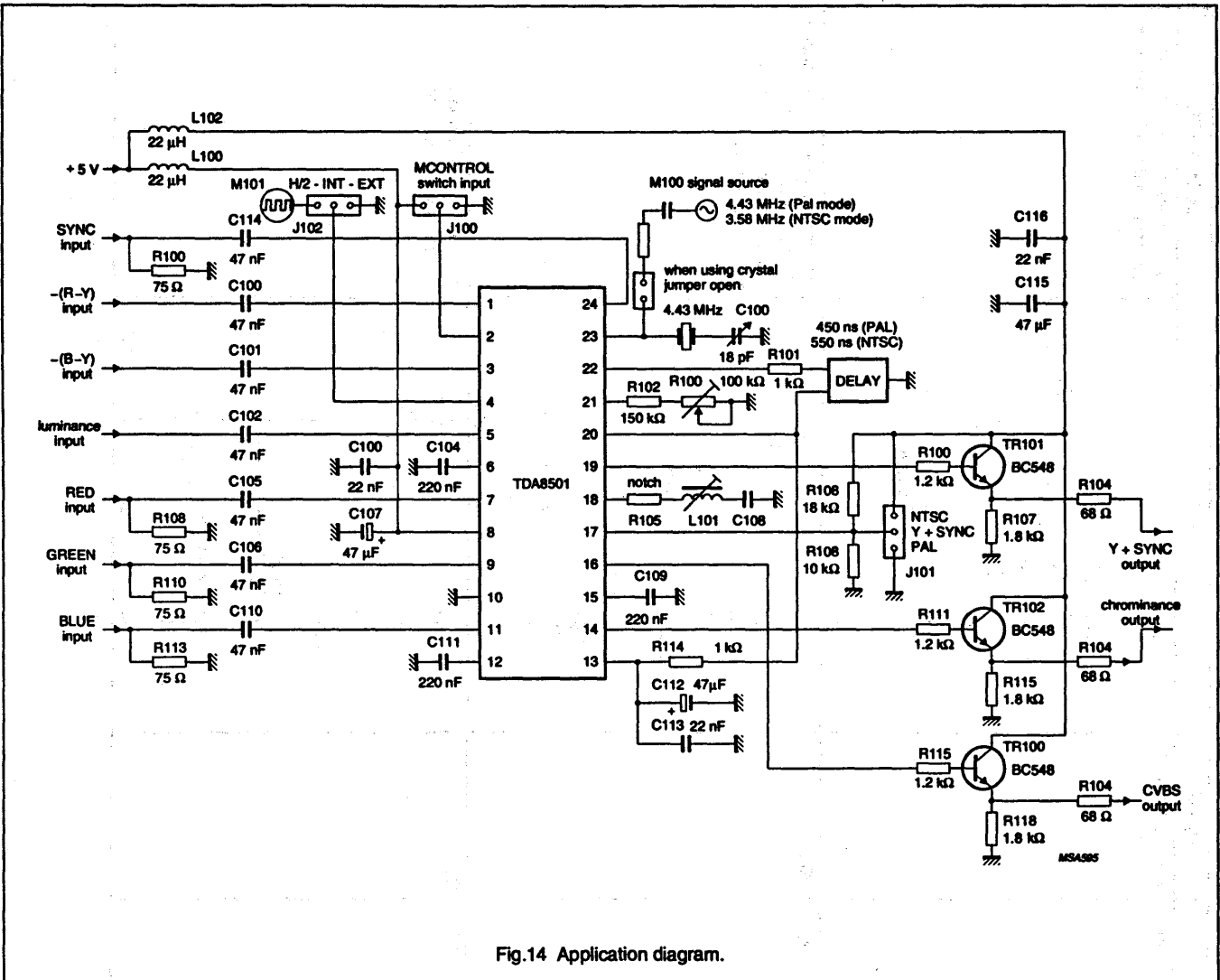

Fig.14 Application diagram.

# 4 × 4 video switch matrix

# TDA8540

### FEATURES

- I<sup>2</sup>C-bus or the non-I<sup>2</sup>C-bus mode (controlled by DC voltages)
- Slave receiver in the I<sup>2</sup>C mode
- S-VHS or CVBS processing
- 3-state switches for all channels
- Selectable gain for the video channels
- sub-address facility
- Auxiliary logic outputs for audio switching
- System expansion possible up to 7 devices (28 sources)
- Static short-circuit proof outputs
- ESD protection.

### APPLICATIONS

- CTV receivers
- Peritelevision sets
- Satellite receivers.

### GENERAL DESCRIPTION

The TDA8540 has been designed primarily for switching between composite video signals. Consequently, a minimum of four input lines has been provided as required for switching between two S-VHS sources. Each of the four outputs can be set to a high impedance state, permitting parallel connection to several devices.

### QUICK REFERENCE DATA

SYMBOL	PARAMETER	CONDITIONS	MIN.	TYP.	MAX.	UNIT
V <sub>cc</sub>	supply voltage		7.2	–	8.8	V
I <sub>cc</sub>	supply current		–	20	30	mA
I <sub>so</sub>	isolation "OFF" state	at f = 5 MHz	60	80	–	dB
B	3 dB bandwidth		12	–	–	MHz
α	crosstalk attenuation between channels		60	70	–	dB

### ORDERING INFORMATION

EXTENDED TYPE NUMBER	PACKAGE			
	PINS	PIN POSITION	MATERIAL	CODE
TDA8540	20	DIL	plastic	SOT146E
TDA8540T	20	SO	plastic	SOT163A

4 × 4 video switch matrix

TDA8540

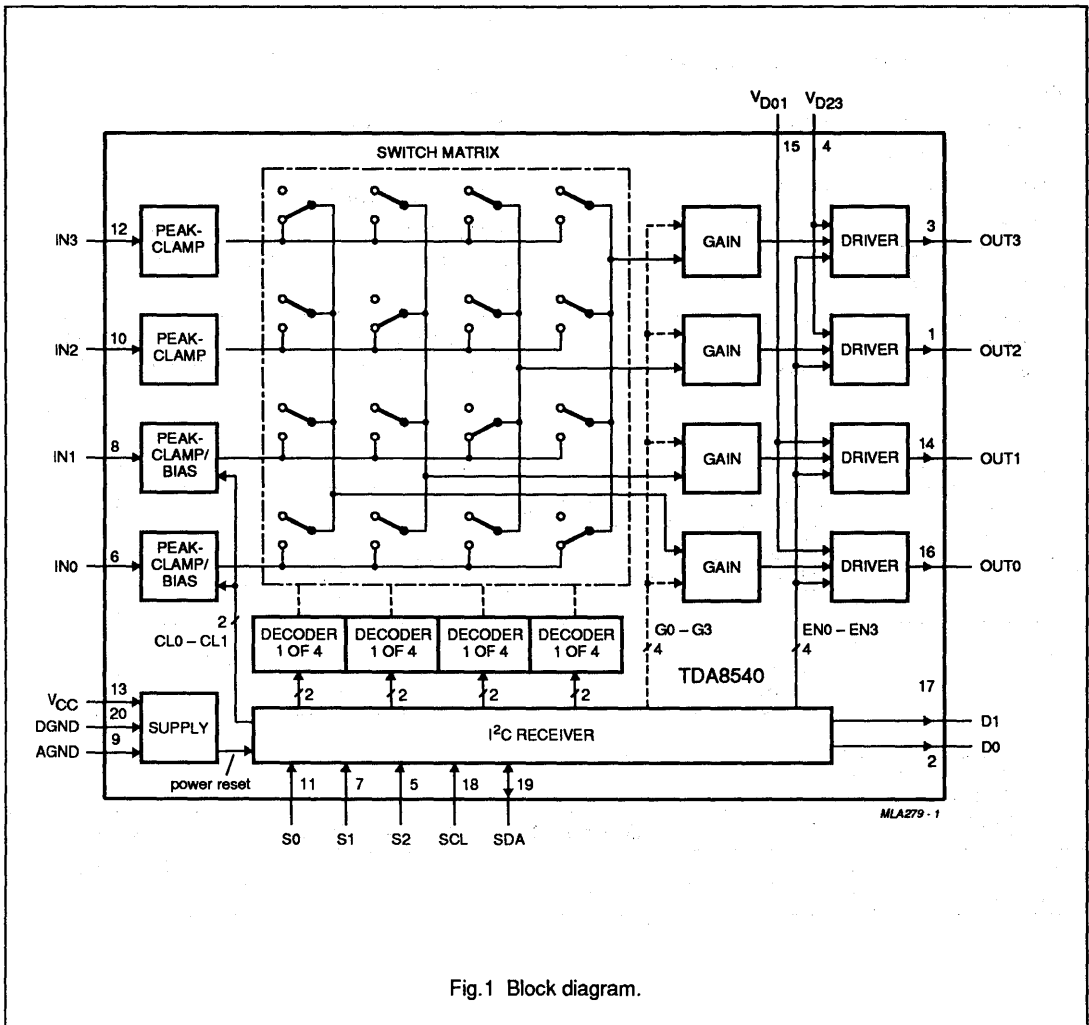

Fig.1 Block diagram.



## 4 × 4 video switch matrix

TDA8540

## PINNING

SYMBOL	PIN	DESCRIPTION
OUT2	1	video output 2
DO	2	control output
OUT3	3	video output 3
V <sub>D23</sub>	4	driver supply
S2	5	sub-address input 2
IN0	6	video input (CVBS or chrominance signal)
S1	7	sub-address input 1
IN1	8	video input (CVBS or chrominance signal)
AGND	9	analog ground
IN2	10	video input (CVBS or luminance signal)
SO	11	sub-address input 0
IN3	12	video input (CVBS or luminance signal)
V <sub>CC</sub>	13	positive supply voltage
OUT1	14	video output 1
V <sub>D01</sub>	15	driver supply
OUT0	16	video output 0
D1	17	control output
SCL	18	serial clock input
SDA	19	serial data input/output
DGND	20	digital ground

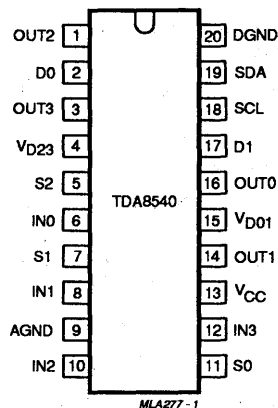

Fig.2 Pinning configuration.

## 4 × 4 video switch matrix

TDA8540

**FUNCTIONAL DESCRIPTION**

The TDA8540 is controlled via a bi-directional I<sup>2</sup>C-bus. 3-bits of the I<sup>2</sup>C address can be selected via sub-address input pins, thus providing a facility for parallel operation of 7 devices.

Control options via the I<sup>2</sup>C-bus:

- the input signals can be clamped at their negative peak (top sync).
- the gain factor of the outputs can be selected between 1× or 2×.
- each of the four outputs can be individually connected to one of the four inputs.
- each output can be individually set in a high impedance state.
- two binary output data lines can be controlled for switching accompanying sound signals.

The SDA and SCL pins (pins 19 and 18) can be connected to the I<sup>2</sup>C-bus or to DC switching voltage sources. Address inputs S0 to S2 (pins 11, 7 and 5) are used to select sub-addresses for switching to the non-I<sup>2</sup>C mode. Inputs S0, S1 and S2 can be connected to the supply voltage (HIGH) or the ground (LOW). In this way no peripheral components are required for selection.

**Table 1** I<sup>2</sup>C-bus sub-addressing.

S2	S1	S0	sub-address		
			A2	A1	A0
L	L	L	0	0	0
L	L	H	0	0	1
L	H	L	0	1	0
L	H	H	0	1	1
H	L	L	1	0	0
H	L	H	1	0	1
H	H	L	1	1	0
H	H	H	non I <sup>2</sup> C addressable		

## 4 × 4 video switch matrix

TDA8540

**I<sup>2</sup>C-bus control**

After power-up the outputs are initialized in the high impedance state, and D0, D1 are at a low level.

Detailed information on I<sup>2</sup>C-bus is available on request.

The TDA8540 is a SLAVE RECEIVER with the following protocol:

S	SLV	A	SUB	A	DATA	A	DATA	A	P
---	-----	---	-----	---	------	---	------	---	---

Where:

- S : start condition
- A : acknowledge bit (generated by TDA8540)
- P : stop condition.

Data transmission to the TDA8540 begins with the following slave address (SLV):

	MSB							LSB		
SLV:	A6	A5	A4	A3	A2	A1	A0	R/W		

Where:

A6 = 1, A5 = 0, A4 = 0, A3 = 1

A2, A1, A0 : pin programmable address bits

R/W = 0 (write only)

Where:

if SUB = 00H : access to switch control (SW1)

if SUB = 01H : access to gain/clamp/data control (GCO)

if SUB = 02H : access to output enable control (OEN)

After the slave address, a second byte, SUB, is required for selecting the functions:

	MSB							LSB		
SUB:	0	0	0	0	0	0	RS1	RS0		

**Note**

If more than one data byte is sent, the SUB byte will be automatically incremented

If more than 3 data bytes are sent, the internal counter will roll over and the device will then rewrite the first register.

## 4 × 4 video switch matrix

TDA8540

## DATA BYTES

- SWI (SUB = 00H)

SWI (SUB = 00H) determines which input is connected to the different outputs:

	MSB								LSB	
SWI:	S31	S30	S21	S20	S11	S10	S01	S00		

For J = 0 to 3:	S <sub>1</sub> , S <sub>0</sub>	00	01	10	11
	OUT <sub>J</sub>	IN0	IN1	IN2	IN3

Example : if S21 = 0 and S20 = 1, then OUT2 is connected to IN1.

- GCO (SUB = 01H)
- selects the gain of each output
- selects the clamp action or mean value on inputs 0 and 1
- determines the value of the auxiliary outputs D1 and D0

	MSB								LSB	
GCO:	G3	G2	G1	G0	CL1	CL0	D1	D0		

- for j = 0 to 3 : if G<sub>j</sub> = 0 (resp 1), then output j has a gain of 2 (resp 1)
- if CL0 (resp CL1) = 0, then input signal on IN0 (resp IN1) is clamped
- for j = 0.1 : if D<sub>j</sub> = 0 (resp 1), then logical output j is LOW (resp HIGH).

OEN (SUB = 02H) determines which output is active or high impedance:

	MSB								LSB	
OEN:	X	X	X	X	EN3	EN2	EN1	EN0		

- for j = 0 to 3 : if EN<sub>j</sub> = 0 (resp 1), then OUT J is HIGHZ (resp ACTIVE).

After a power-on reset: the outputs are set to a high impedance state; the outputs are connected to IN0; the gains are set at two and inputs IN0 and IN1 are clamped.

After a power-on reset, the programming of the device is required by the outputs being in a high impedance state.

## 4 × 4 video switch matrix

TDA8540

**Non- $\mu$ C-bus Control**

If the S0, S1 and S2 pins are all tied to  $V_{CC}$  the device will then enter the non- $\mu$ C mode.

- After a power-on reset :
  - gain is set at two for all outputs
  - all inputs are clamped
  - all outputs are active
  - the matrix position is given by SDA and SCL voltage level..

**Table 2** Non  $\mu$ C-bus Control.

SCL - SDA	0.0	0.1	1.0	1.1
OUT3	IN3	IN2	IN1	IN0
OUT2	IN2	IN3	IN0	IN1
OUT1	IN1	IN0	IN3	IN2
OUT0	IN0	IN1	IN2	IN3

SCL and SDA act as normal input pins:

- SCL interchanges (OUT3 and OUT2) with (OUT1 and OUT0).
- SDA interchanges OUT3 with OUT2; OUT1 with OUT0.

**Note:**

For use with chrominance signals, the clamp action must be overruled by external bias.

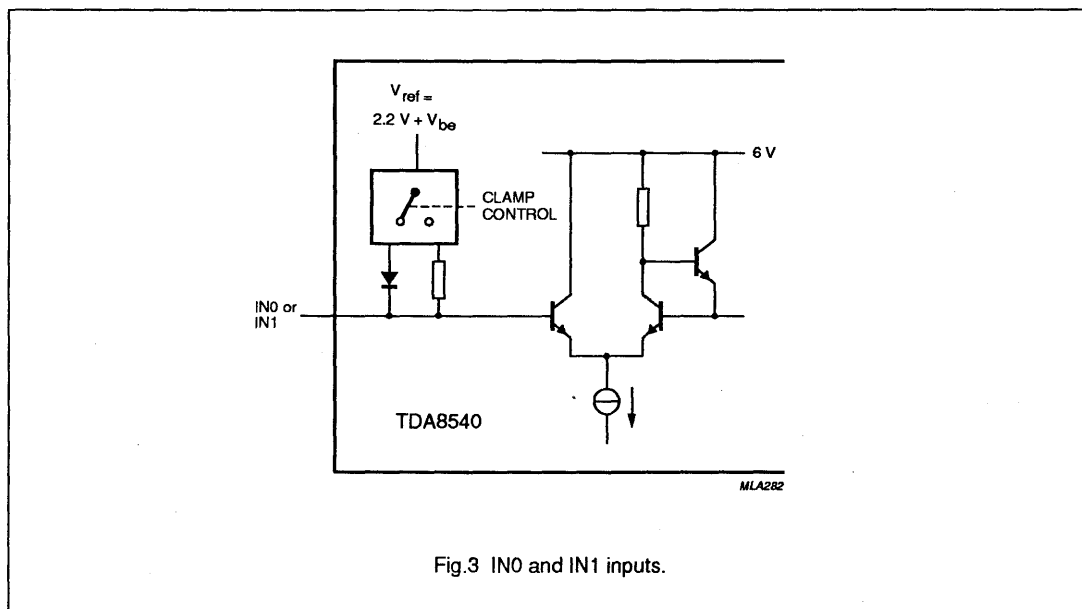
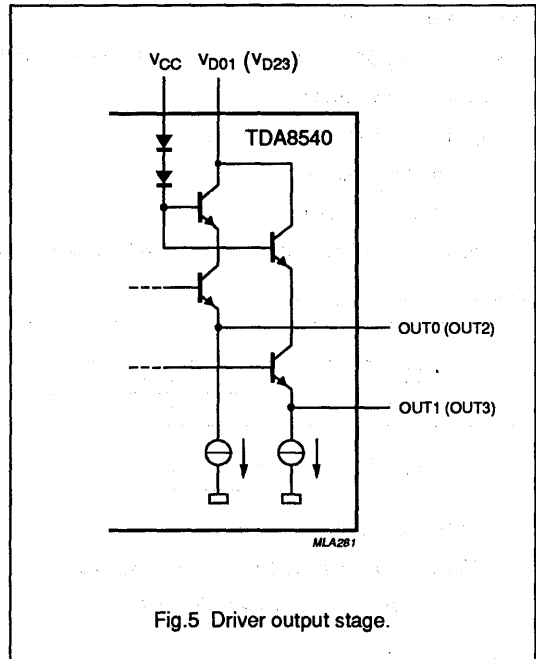
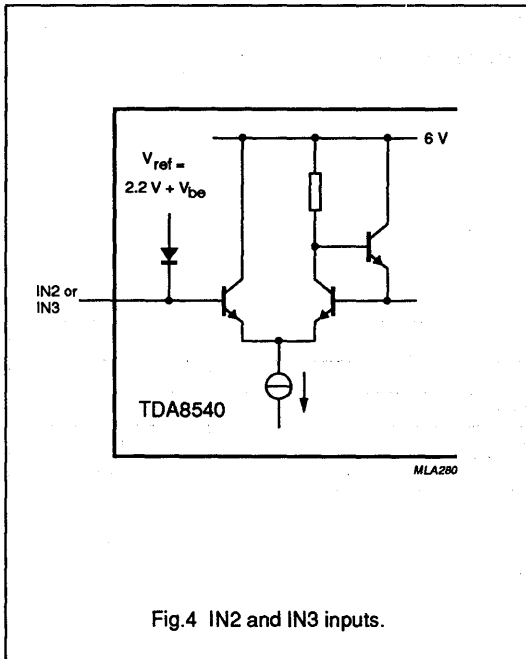

Fig.3 IN0 and IN1 inputs.

4 × 4 video switch matrix

TDA8540



## 4 × 4 video switch matrix

TDA8540

**LIMITING VALUES**

In accordance with the Absolute Maximum System (IEC 134).

SYMBOL	PARAMETER	MIN.	MAX.	UNIT
$V_{CC}$	supply voltage	-0.3	9.1	V
$P_{tot}$	total power dissipation	-	750	mW
$T_{stg}$	storage temperature	-55	+125	°C
$T_j$	maximum junction temperature	-	+150	°C
$V_{D01}, V_{D23}$	driver supply input voltage	-0.3	13.8	V
INO to IN3	video input voltage	-0.3	7.2	V
OUT0 to OUT3	video output voltage	-0.3	7.2	V
D0, D1	control output voltage	-0.3	7.2	V
SDA, SDL	I <sup>2</sup> C input/output voltage	-0.3	8.8	V
S0 to S2	sub-address input voltage	-0.3	8.8	V

**Handling**

## HUMAN BODY MODEL

The IC withstands 1500 V in accordance with UZW-BO-FQ-A303.

## MACHINE MODEL

The IC withstands 200 V in accordance with UZW-BO-FQ-B303 (stress reference pins : AGND - GNDD short-circuit and  $V_{CC}$ ).**THERMAL RESISTANCE**

SYMBOL	PARAMETER	THERMAL RESISTANCE
$R_{th\ j-a}$	from junction to ambient in free air	
	SOT146	60 K/W
	SOT163A	85 K/W

## 4 × 4 video switch matrix

TDA8540

## OPERATING CHARACTERISTICS

SYMBOL	PARAMETER	CONDITIONS	MIN.	TYP.	MAX.	UNIT
V <sub>CC</sub>	supply voltage		7.2	–	8.8	V
T <sub>amb</sub>	operating ambient temperature		0	–	70	°C
<b>Video inputs (pins 6, 8, 10 and 12)</b>						
C <sub>I</sub>	external capacitor		–	100	–	nF
V <sub>I</sub>	C signal amplitude (peak-to-peak value)	note 1	–	–	1	V
V <sub>I</sub>	CVBS or Y-signal amplitude (peak-to-peak value)	note 2	–	–	1.5	V
<b>Video drivers (pins 4 and 15)</b>						
R <sub>D</sub>	external collector resistor	note 3	–	25	–	Ω
C <sub>D</sub>	external decoupling capacitor	note 4	–	22	–	μF
<b>sub-address S0, S1 and S2 (pins 5, 7 and 11)</b>						
V <sub>IH</sub>	HIGH level input voltage		4	–	V <sub>CC</sub>	V
V <sub>IL</sub>	LOW level input voltage		0	–	1	V

## Notes to the Operating Characteristics:

1. Only for pins 6 and 8 when clamp action is not selected for these pins.
2. On all the video input pins when non-I<sup>2</sup>C-bus control mode is selected or when clamp action is selected on pins 6 and 8 (by I<sup>2</sup>C-bus control).
3. Connected between V<sub>CC</sub> and pin 4 or pin 15.
4. Connected between AGRND and pin 4 or pin 15.



## 4 × 4 video switch matrix

TDA8540

**CHARACTERISTICS**

$V_{CC} = 8\text{ V}$ ;  $T_{amb} = 25\text{ °C}$ ; gain condition, clamp condition and OFF state are controlled by the I<sup>2</sup>C bus unless otherwise specified.

SYMBOL	PARAMETER	CONDITIONS	MIN.	TYP.	MAX.	UNIT
<b>Supply</b>						
$I_{CC}$	supply current	without load	–	20	30	mA
		OFF state	–	12	–	mA
<b>Video inputs : IN0 to IN3 when the clamp is active (see Figs 3 and 4)</b>						
$I_U$	input leakage current	$V_i = 3\text{ V}$	–	0.4	1	mA
$V_{clamp}$	input clamping voltage	$I_i = 5\text{ }\mu\text{A}$	–	2.2	–	V
$I_{clamp}$	input clamping current	$V_i = 0\text{ V}$	1.2	–	–	mA
<b>Video inputs : IN0 and IN2 when the clamp is not active (see Fig.3)</b>						
$V_{bias}$	DC input bias level	$I_i = 0$	–	2.9	–	V
$R_i$	input resistance		–	10	–	k $\Omega$
<b>Video outputs : OUT0 to OUT3 (see Fig.5)</b>						
$Z_o$	output impedance	OFF state	100	–	–	k $\Omega$
$R_o$	output resistance		–	5	–	$\Omega$
ISO	isolation	OFF state $f = 5\text{ MHz}$	60	–	–	dB
$V_o$	output top sync level (Y or CVBS)		0.4	0.7	1	V
$V_{bias}$	output mean value for chrominance signals	$G = 2$ , load = 150 $\Omega$	1.5	1.9	2.2	V
		$G = 1$ , without load	1	1.3	1.6	V
$G_v$	voltage gain	$G = 1$ ; $f = 1\text{ MHz}$	–1	0	+1	dB
		$G = 2$ ; $f = 1\text{ MHz}$	+5	+6	+7	dB
$G_{diff}$	differential gain	note 1	–	0.5	3	%
$\Phi_{diff}$	differential phase	note 1	–	0.6	–	deg
NL	non linearity	note 2	–	0.5	2	%
$\alpha$	crosstalk attenuation between channels	note 3	60	70	–	dB
SVRR	supply voltage rejection	note 4	36	55	–	dB
$\Delta G$	maximum gain variation	100 kHz < $f$ < 5 MHz	–	0.5	–	dB
		100 kHz < $f$ < 8.5 MHz	–	1	–	dB
		100 kHz < $f$ < 12 MHz	–	3	–	dB
$\alpha I^2C$	crosstalk attenuation of bus signals		60	–	–	dB
<b>Auxiliary outputs D0, D1 (open collector)</b>						
$I_{OH}$	HIGH level output current	$V_{OH} = 5.5\text{ V}$	–	–	10	mA
$V_{OL}$	LOW level output voltage	$I_{OL} = 4\text{ mA}$	–	–	0.4	V

## 4 × 4 video switch matrix

TDA8540

SYMBOL	PARAMETER	CONDITIONS	MIN.	TYP.	MAX.	UNIT
<b>I<sup>2</sup>C-bus inputs SCL, SDA</b>						
I <sub>IH</sub>	HIGH level input current	V <sub>IH</sub> = 3.0 V	–	–	10	μA
I <sub>IL</sub>	LOW level input current	V <sub>IL</sub> = 1.5 V	–10	–	–	μA
C <sub>I</sub>	input capacitance		–	–	10	pF
<b>I<sup>2</sup>C-bus output SDA</b>						
V <sub>OL</sub>	LOW level output voltage	I <sub>OL</sub> = 3 mA	–	–	0.4	V
<b>sub-address S0, S1 and S2</b>						
I <sub>IH</sub>	HIGH level input current	V <sub>IH</sub> = V <sub>CC</sub>	–	–	10	μA
I <sub>IL</sub>	LOW level input current	V <sub>IL</sub> = 0 V	–	–	10	μA

**Notes to the Characteristics:**

- Gain set at two, R<sub>L</sub> = 150 Ω, test signal D2 from CCIR 330.
- Gain set at two, R<sub>L</sub> = 150 Ω, test signal D1 from CCIR 17.
- Measured from any selected input to output; f = 5 MHz, R<sub>L</sub> = 150 Ω, gain set at 2, V<sub>i</sub> = 1.5 V (p-p).  
This measurement requires an optimized board.
- Supply voltage ripple rejection:  $20 \log \frac{V_{(supply)}}{V_{(output)}}$  measured at f = 1 kHz with V<sub>r(supply max)</sub> = 100 mV (p-p).

The supply voltage rejection ratio is higher than 36 dB at f<sub>max</sub> = 100 kHz.

4 × 4 video switch matrix

TDA8540

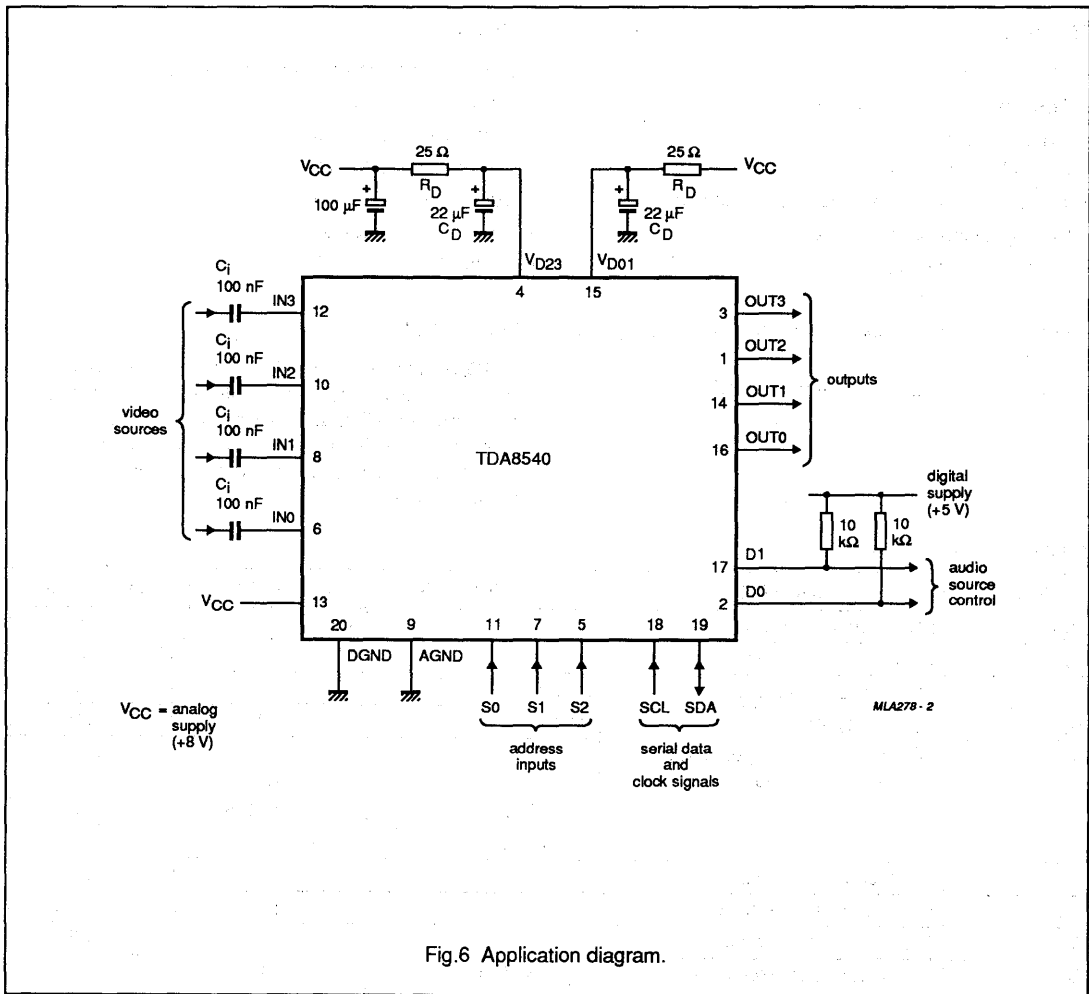

Fig.6 Application diagram.

# 8-bit video digital-to-analog converter

# TDA8702

## FEATURES

- 8-bit resolution
- Conversion rate up to 30 MHz
- TTL input levels
- Internal reference voltage generator
- Two complementary analog voltage outputs
- No deglitching circuit required
- Internal input register
- Low power dissipation
- Internal 75 Ω output load (connected to the analog supply)
- Very few external components required.

## APPLICATIONS

- High-speed digital-to-analog conversion
- Digital TV including:
  - field progressive scan
  - line progressive scan
- Subscriber TV decoders
- Satellite TV decoders
- Digital VCRs.

## DESCRIPTION

The TDA8702 is an 8-bit digital-to-analog converter (DAC) for video and other applications. It converts the digital input signal into an analog voltage output at a maximum conversion rate of 30 MHz. No external reference voltage is required and all digital inputs are TTL compatible.

## QUICK REFERENCE DATA

SYMBOL	PARAMETER	CONDITIONS	MIN.	TYP.	MAX.	UNIT
$V_{CCA}$	analog supply voltage		4.5	5.0	5.5	V
$V_{CCD}$	digital supply voltage		4.5	5.0	5.5	V
$I_{CCA}$	analog supply current	note 1	–	26	32	mA
$I_{CCD}$	digital supply current	note 1	–	23	30	mA
$V_{OUT} - \overline{V_{OUT}}$	full-scale analog output voltage (peak-to-peak value)	note 2				
		$Z_L = 10\text{ k}\Omega$	–1.45	–1.60	–1.75	V
		$Z_L = 75\text{ k}\Omega$	–0.72	–0.80	–0.88	V
ILE	DC integral linearity error		–	–	±1/2	LSB
DLE	DC differential linearity error		–	–	±1/2	LSB
$f_{CLK}$	maximum conversion rate		–	–	30	MHz
B	–3 dB analog bandwidth	$f_{CLK} = 30\text{ MHz};$ note 3	–	150	–	MHz
$P_{tot}$	total power dissipation		–	250	340	mW

## Notes

1. D0 to D7 connected to  $V_{CCD}$  and CLK connected to DGND.
2. The analog output voltages ( $V_{OUT}$  and  $\overline{V_{OUT}}$ ) are negative with respect to  $V_{CCA}$  (see Table 1). The output resistance between  $V_{CCA}$  and each of these outputs is typically 75 Ω.
3. The –3 dB analog output bandwidth is determined by real time analysis of the output transient at a maximum input code transition (code 0 to 255).

8-bit video digital-to-analog converter

TDA8702

ORDERING INFORMATION

EXTENDED TYPE NUMBER	PACKAGE			
	PINS	PIN POSITION	MATERIAL	CODE
TDA8702	16	DIL	plastic	SOT38
TDA8702T	16	SO16	plastic	SOT162A

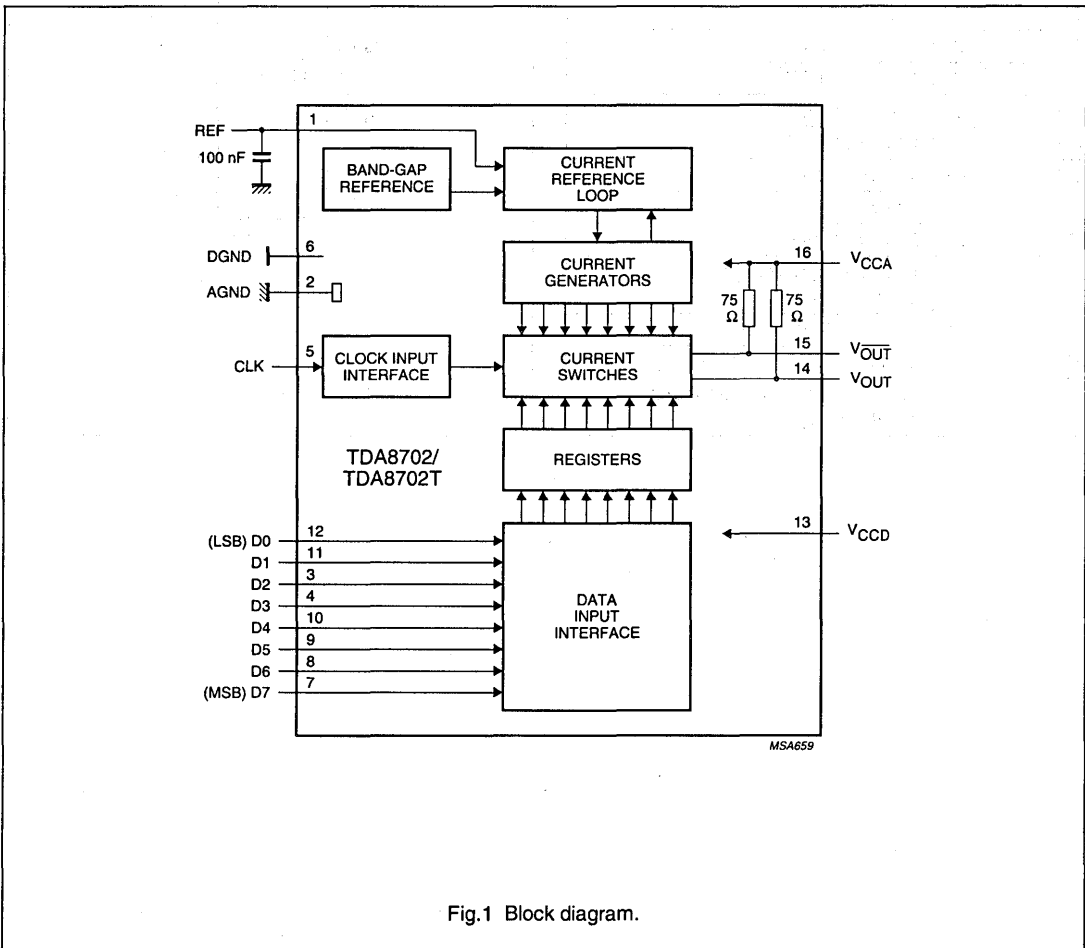

Fig.1 Block diagram.

8-bit video digital-to-analog converter

TDA8702

PINNING

SYMBOL	PIN	DESCRIPTION
REF	1	voltage reference (decoupling)
AGND	2	analog ground
D2	3	data input; bit 2
D3	4	data input; bit 3
CLK	5	clock input
DGND	6	digital ground
D7	7	data input; bit 7
D6	8	data input; bit 6
D5	9	data input; bit 5
D4	10	data input; bit 4
D1	11	data input; bit 1
D0	12	data input; bit 0
V <sub>CCD</sub>	13	positive supply voltage for digital circuits (+5 V)
V <sub>OUT</sub>	14	analog voltage output
V <sub>OUT</sub>	15	complementary analog voltage output
V <sub>CCA</sub>	16	positive supply voltage for analog circuits (+5 V)

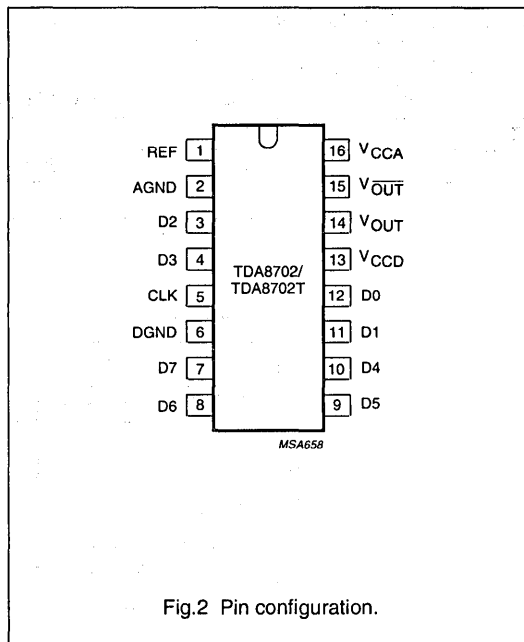

## 8-bit video digital-to-analog converter

TDA8702

**LIMITING VALUES**

In accordance with the Absolute Maximum Rating System (IEC 134).

SYMBOL	PARAMETER	MIN.	MAX.	UNIT
$V_{CCA}$	analog supply voltage	-0.3	+7.0	V
$V_{CCD}$	digital supply voltage	-0.3	+7.0	V
$V_{CCA} - V_{CCD}$	supply voltage differential	-0.5	+0.5	V
AGND - DGND	ground voltage differential	-0.1	+0.1	V
$V_I$	input voltage (pins 3 to 5 and 7 to 12)	-0.3	$V_{CCD}$	V
$I_{OUT}/\overline{I_{OUT}}$	total output current (pins 14 and 15)	-5	+26	mA
$T_{stg}$	storage temperature	-55	+150	°C
$T_{amb}$	operating ambient temperature	0	+70	°C
$T_J$	junction temperature	-	+125	°C

**THERMAL RESISTANCE**

SYMBOL	PARAMETER	THERMAL RESISTANCE
$R_{th\ j-a}$	from junction to ambient in free air	
	SOT38	70 K/W
	SOT162A	90 K/W

**HANDLING**

Inputs and outputs are protected against electrostatic discharges in normal handling. However, to be totally safe, it is desirable to take normal precautions appropriate to handling integrated circuits.

## 8-bit video digital-to-analog converter

TDA8702

**CHARACTERISTICS**

$V_{CCA} = V_{16} - V_2 = 4.5 \text{ V to } 5.5 \text{ V}$ ;  $V_{CCD} = V_{13} - V_6 = 4.5 \text{ V to } 5.5 \text{ V}$ ;  $V_{CCA} - V_{CCD} = -0.5 \text{ V to } +0.5 \text{ V}$ ;  $V_{REF}$  decoupled to AGND by a 100 nF capacitor;  $T_{amb} = 0 \text{ }^\circ\text{C to } +70 \text{ }^\circ\text{C}$ ; AGND and DGND shorted together; unless otherwise specified (typical values measured at  $V_{CCA} = V_{CCD} = 5 \text{ V}$  and  $T_{amb} = 25 \text{ }^\circ\text{C}$ ).

SYMBOL	PARAMETER	CONDITIONS	MIN.	TYP.	MAX.	UNIT
<b>Supply</b>						
$V_{CCA}$	analog supply voltage		4.5	5.0	5.5	V
$V_{CCD}$	digital supply voltage		4.5	5.0	5.5	V
$I_{CCA}$	analog supply current	note 1	–	26	32	mA
$I_{CCD}$	digital supply current	note 1	–	23	30	mA
AGND – DGND	ground voltage differential		–0.1	–	+0.1	V
<b>Inputs</b>						
DIGITAL INPUTS (D7 TO D0) AND CLOCK INPUT (CLK)						
$V_{IL}$	LOW level input voltage		0	–	0.8	V
$V_{IH}$	HIGH level input voltage		2.0	–	$V_{CCD}$	V
$I_{IL}$	LOW level input current	$V_I = 0.4 \text{ V}$	–	–0.3	–0.4	mA
$I_{IH}$	HIGH level input current	$V_I = 2.7 \text{ V}$	–	0.01	20	$\mu\text{A}$
$f_{CLK}$	maximum clock frequency		–	–	30	MHz
<b>Outputs (note 2; referenced to <math>V_{CCA}</math>)</b>						
$V_{OUT} - \overline{V_{OUT}}$	full-scale analog output voltages (peak-to-peak value)	$Z_L = 10 \text{ k}\Omega$	–1.45	–1.60	–1.75	V
		$Z_L = 75 \text{ }\Omega$	–0.72	–0.80	–0.88	V
$V_{OS}$	analog offset output voltage	code = 0	–	–3	–25	mV
$V_{OUT}/TC$	full-scale analog output voltage temperature coefficient		–	–	200	$\mu\text{V/K}$
$V_{OS}/TC$	analog offset output voltage temperature coefficient		–	–	20	$\mu\text{V/K}$
B	–3 dB analog bandwidth	note 3; $f_{CLK} = 30 \text{ MHz}$	–	150	–	MHz
$G_{diff}$	differential gain		–	0.6	–	%
$\Phi_{diff}$	differential phase		–	1	–	deg
$Z_O$	output impedance		–	75	–	$\Omega$
<b>Transfer function (<math>f_{CLK} = 30 \text{ MHz}</math>)</b>						
ILE	DC integral linearity error		–	–	$\pm 1/2$	LSB
DLE	DC differential linearity error		–	–	$\pm 1/2$	LSB



## 8-bit video digital-to-analog converter

TDA8702

SYMBOL	PARAMETER	CONDITIONS	MIN.	TYP.	MAX.	UNIT
<b>Switching characteristics (<math>f_{CLK} = 30</math> MHz; notes 4 and 5; see Figs 3, 4 and 5)</b>						
$t_{SU,DAT}$	data set-up time		-0.3	-	-	ns
$t_{HD,DAT}$	data hold time		2.0	-	-	ns
$t_{PD}$	propagation delay time		-	-	1.0	ns
$t_{S1}$	settling time	10% to 90% full-scale change to $\pm 1$ LSB	-	1.1	1.5	ns
$t_{S2}$	settling time	10% to 90% full-scale change to $\pm 1$ LSB	-	6.5	8.0	ns
$t_d$	input to 50% output delay time		-	3.0	5.0	ns
<b>Output transients (glitches; <math>f_{CLK} = 30</math> MHz; note 6; see Fig.6)</b>						
$E_g$	glitch energy from code	transition 127 to 128	-	-	30	LSB.ns

**Notes**

- D0 to D7 are connected to  $V_{CCD}$ , CLK is connected to DGND.
- The analog output voltages ( $V_{OUT}$  and  $V_{OUT-}$  are negative with respect to  $V_{CCA}$  (see Table 1). The output resistance between  $V_{CCA}$  and each of these outputs is 75  $\Omega$  (typ.).
- The -3 dB analog output bandwidth is determined by real time analysis of the output transient at a maximum input code transition (code 0 to 255).
- The worst case characteristics are obtained at the transition from input code 0 to 255 and if an external load impedance greater than 75  $\Omega$  is connected between  $V_{OUT}$  or  $V_{OUT-}$  and  $V_{CCA}$ . The specified values have been measured with an active probe between  $V_{OUT}$  and AGND. No further load impedance between  $V_{OUT}$  and AGND has been applied. All input data is latched at the rising edge of the clock. The output voltage remains stable (independent of input data variations) during the HIGH level of the clock (CLK = HIGH). During a LOW-to-HIGH transition of the clock (CLK = LOW), the DAC operates in the transparent mode (input data will be directly transferred to their corresponding analog output voltages (see Fig.5).
- The data set-up ( $t_{SU,DAT}$ ) is the minimum period preceding the rising edge of the clock that the input data must be stable in order to be correctly registered. A negative set-up time indicates that the data may be initiated after the rising edge of the clock and still be recognized. The data hold time ( $t_{HD,DAT}$ ) is the minimum period following the rising edge of the clock that the input data must be stable in order to be correctly registered. A negative hold time indicates that the data may be released prior to the rising edge of the clock and still be recognized.
- The definition of glitch energy and the measurement set-up are shown in Fig.6. The glitch energy is measured at the input transition between code 127 to 128 and on the falling edge of the clock.

8-bit video digital-to-analog converter

TDA8702

**Table 1** Input coding and output voltages (typical values; referenced to  $V_{CCA}$ , regardless of the offset voltage).

CODE	INPUT DATA (D7 to D0)	DAC OUTPUT VOLTAGES			
		$Z_L = 10\text{ k}\Omega$		$Z_L = 75\ \Omega$	
		$V_{OUT}$	$\overline{V_{OUT}}$	$V_{OUT}$	$\overline{V_{OUT}}$
0	000 00 00	0	-1.6	0	-0.8
1	000 000 01	-0.006	-1.594	-0.003	-0.797
..	.....				
128	100 000 00	-0.8	-0.8	-0.4	-0.4
..	.....				
254	111 111 10	-1.594	-0.006	-0.797	-0.003
255	111 111 11	-1.6	0	-0.8	0

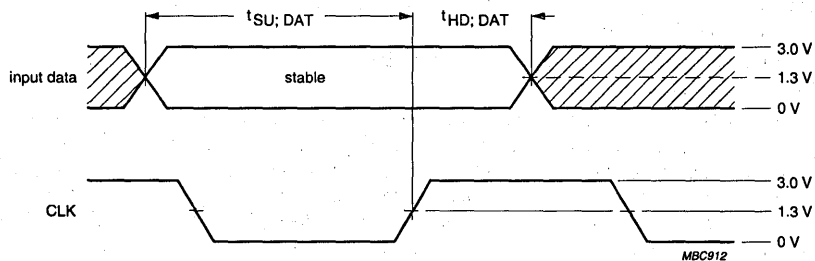

The shaded areas indicate when the input data may change and be correctly registered. Data input update must be completed within 0.3 ns after the first rising edge of the clock ( $t_{SU, DAT}$  is negative; -0.3 ns). Data must be held at least 2 ns after the rising edge ( $t_{HD, DAT} = +2\text{ ns}$ ).

**Fig.3** Data set-up and hold times.

8-bit video digital-to-analog converter

TDA8702

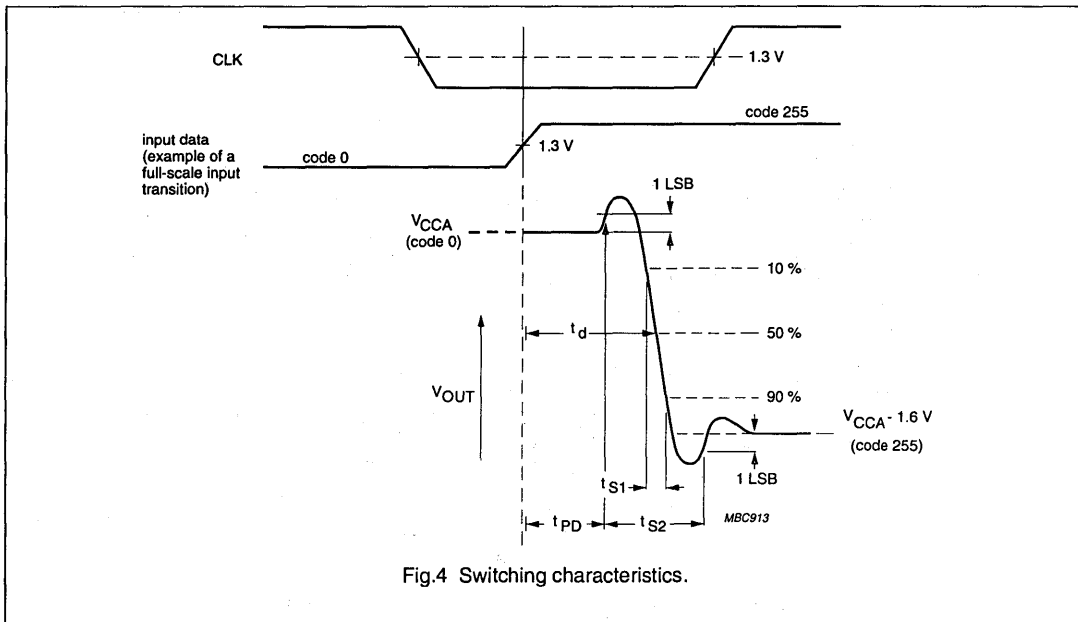
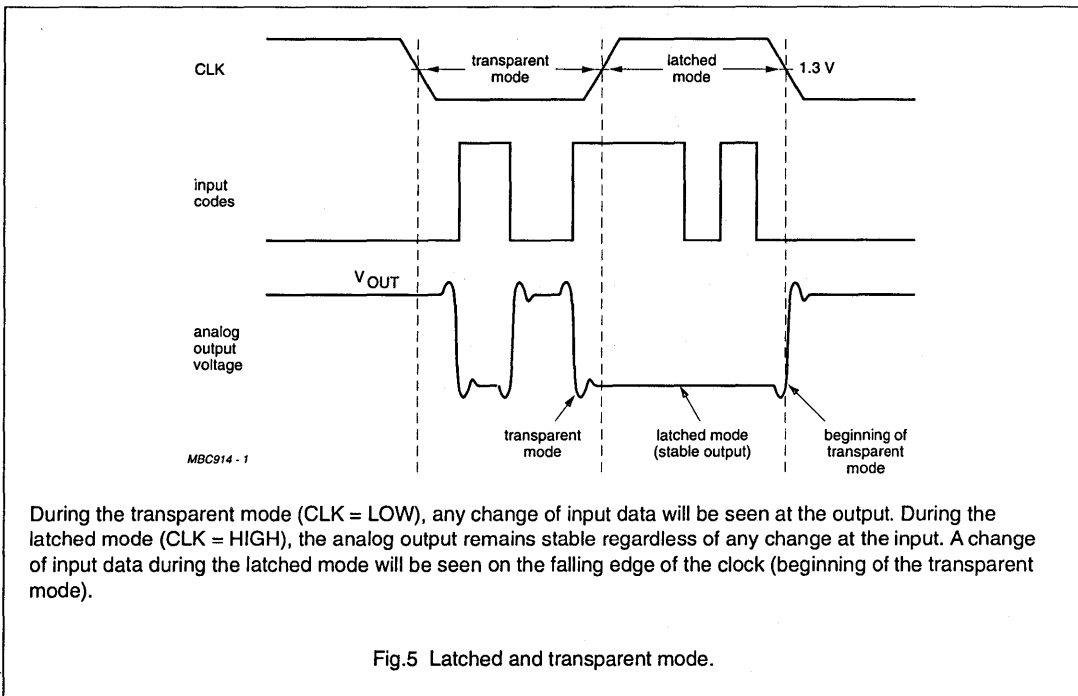

Fig.4 Switching characteristics.



During the transparent mode (CLK = LOW), any change of input data will be seen at the output. During the latched mode (CLK = HIGH), the analog output remains stable regardless of any change at the input. A change of input data during the latched mode will be seen on the falling edge of the clock (beginning of the transparent mode).

Fig.5 Latched and transparent mode.

8-bit video digital-to-analog converter

TDA8702

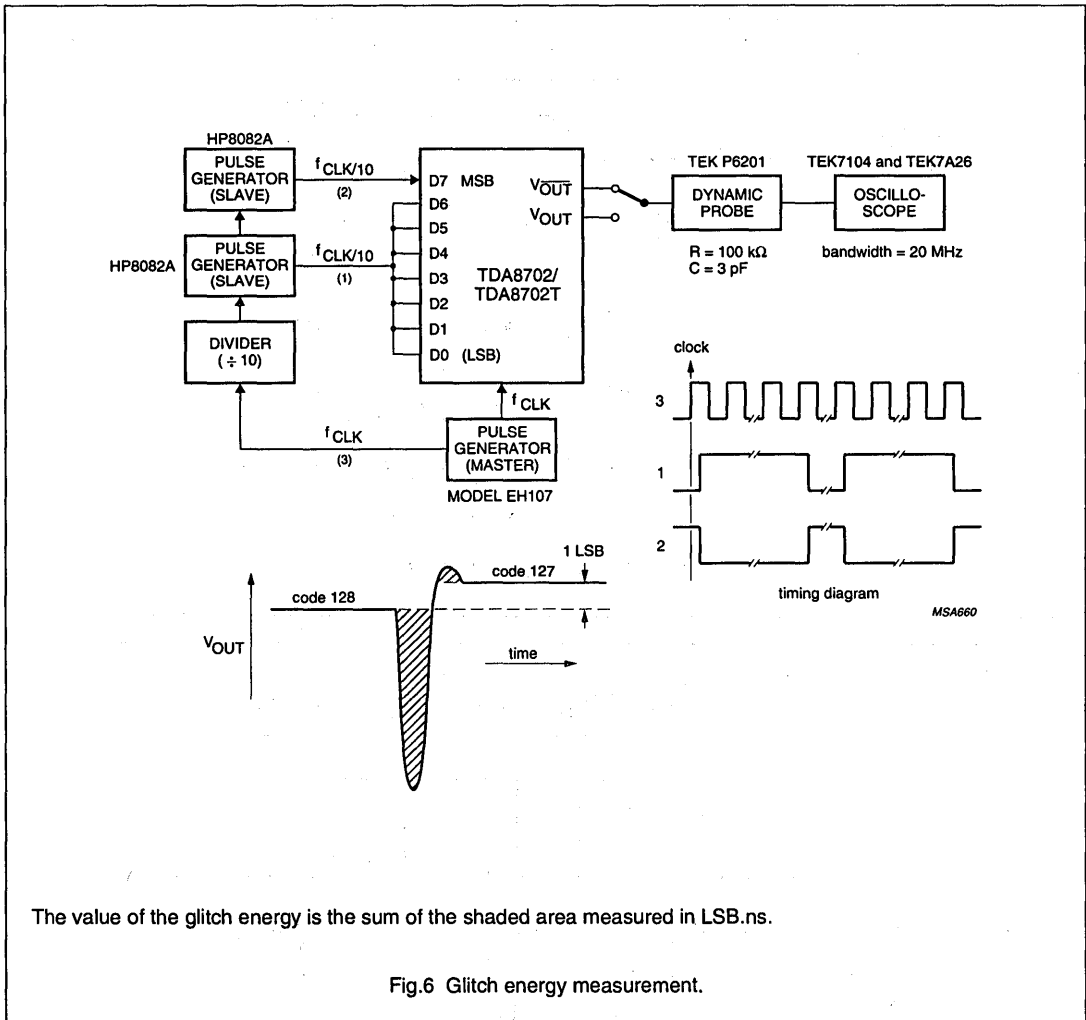

8-bit video digital-to-analog converter

TDA8702

INTERNAL PIN CONFIGURATIONS

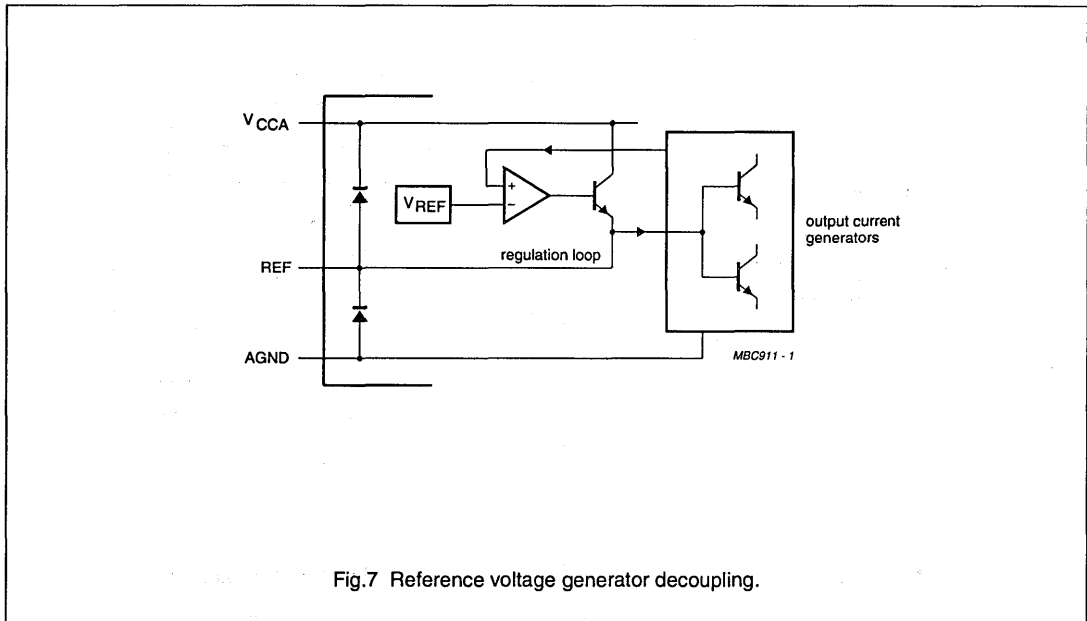

Fig.7 Reference voltage generator decoupling.

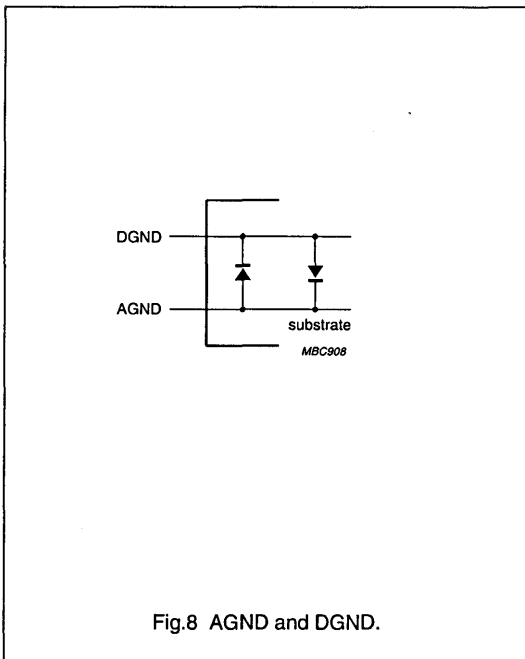

Fig.8 AGND and DGND.

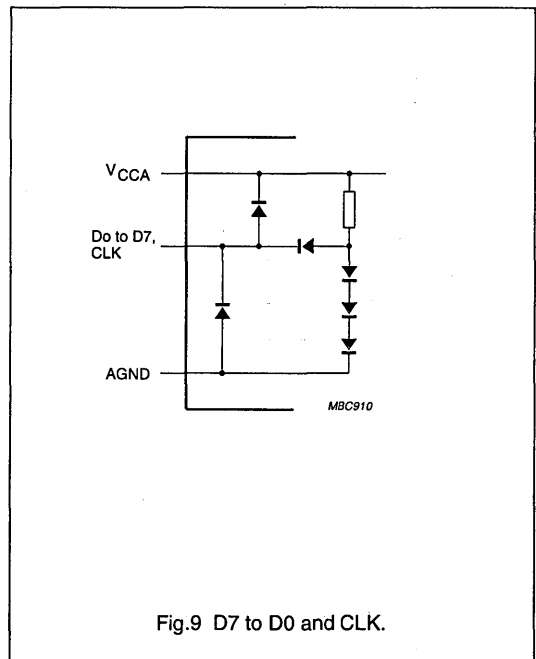
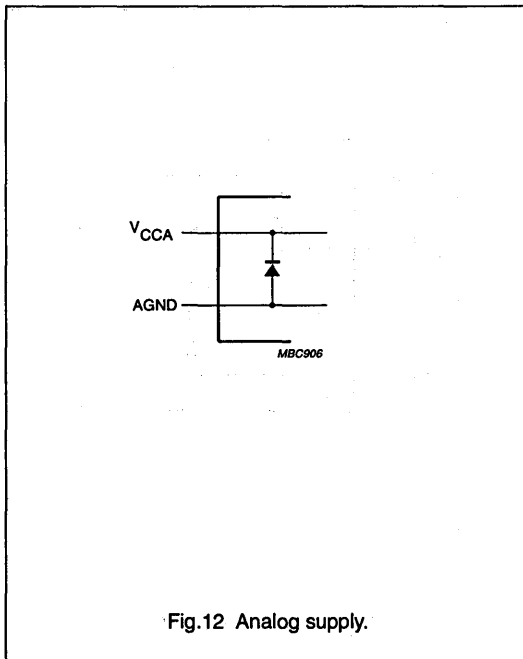
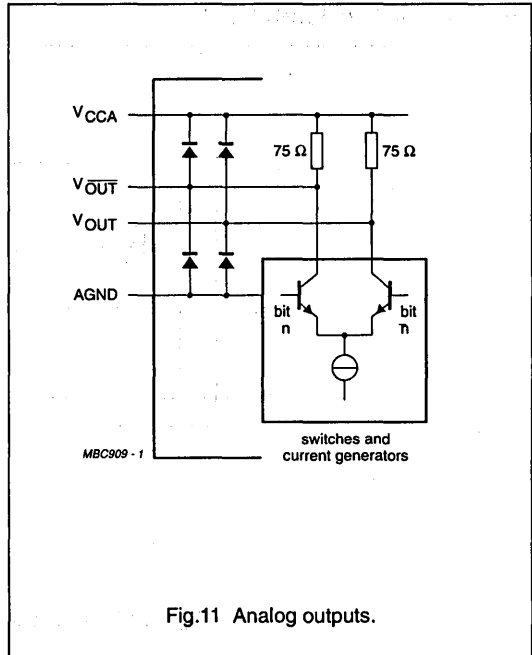
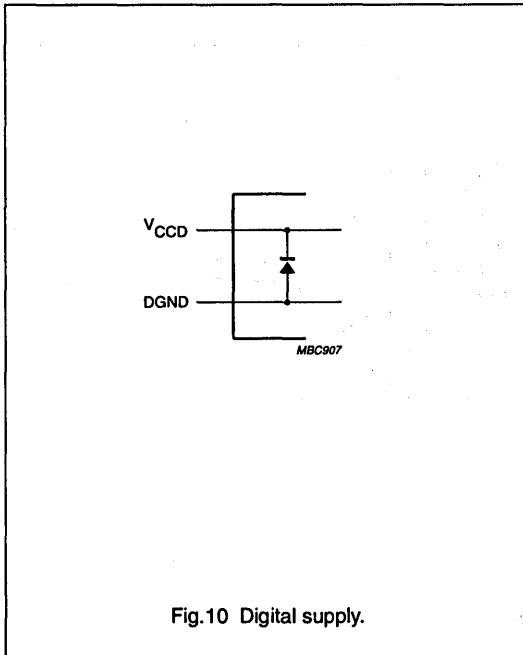

Fig.9 D7 to D0 and CLK.

8-bit video digital-to-analog converter

TDA8702



8-bit video digital-to-analog converter

TDA8702

APPLICATION INFORMATION

Additional application information will be supplied upon request (please quote number FTV/8901).

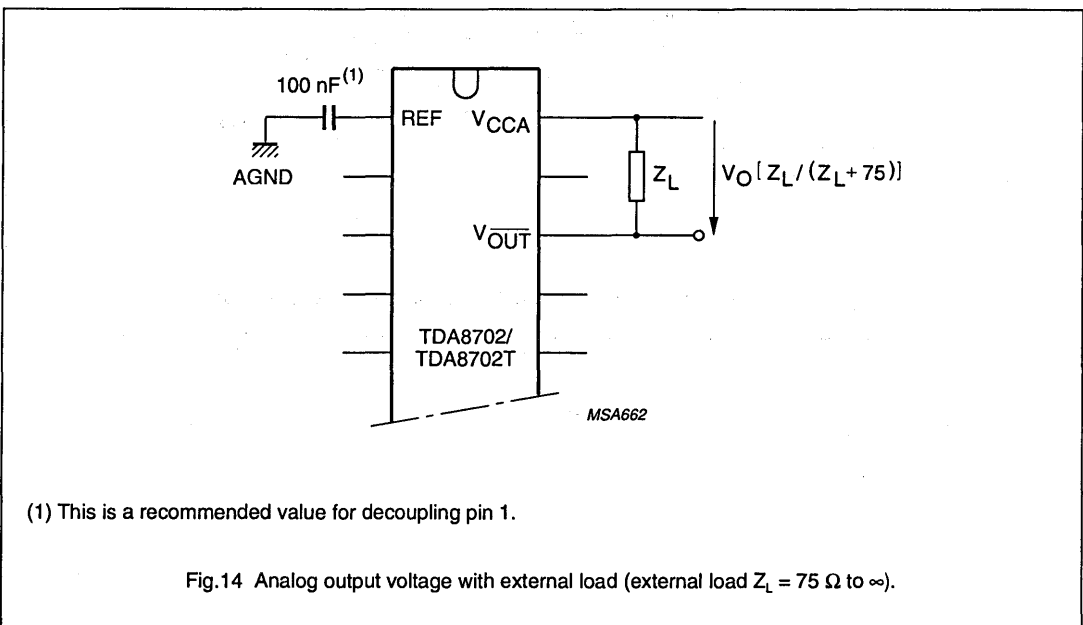
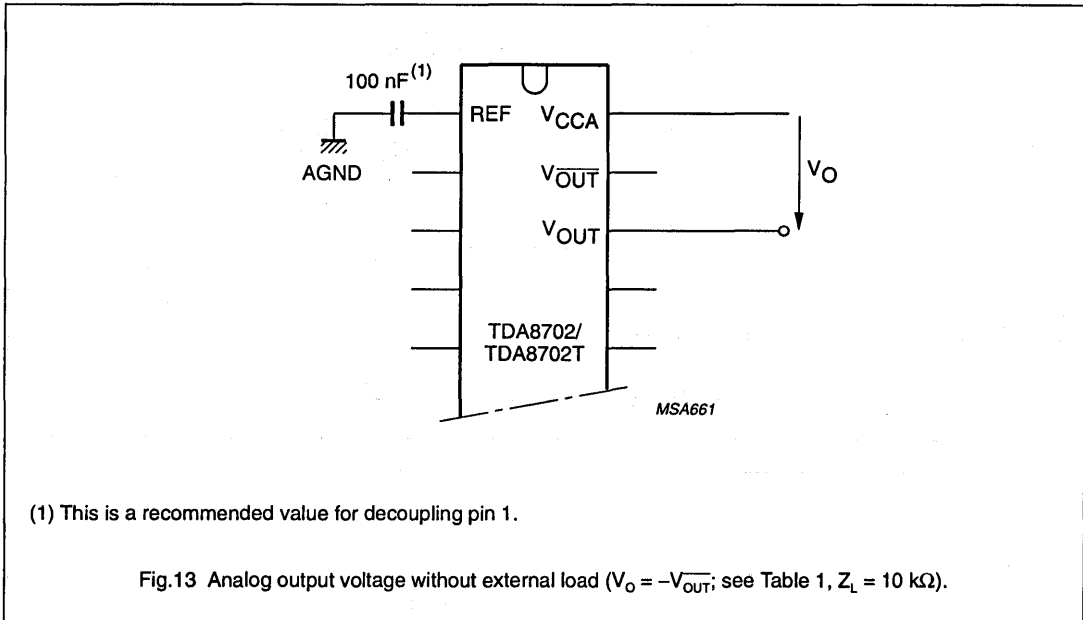

8-bit video digital-to-analog converter

TDA8702

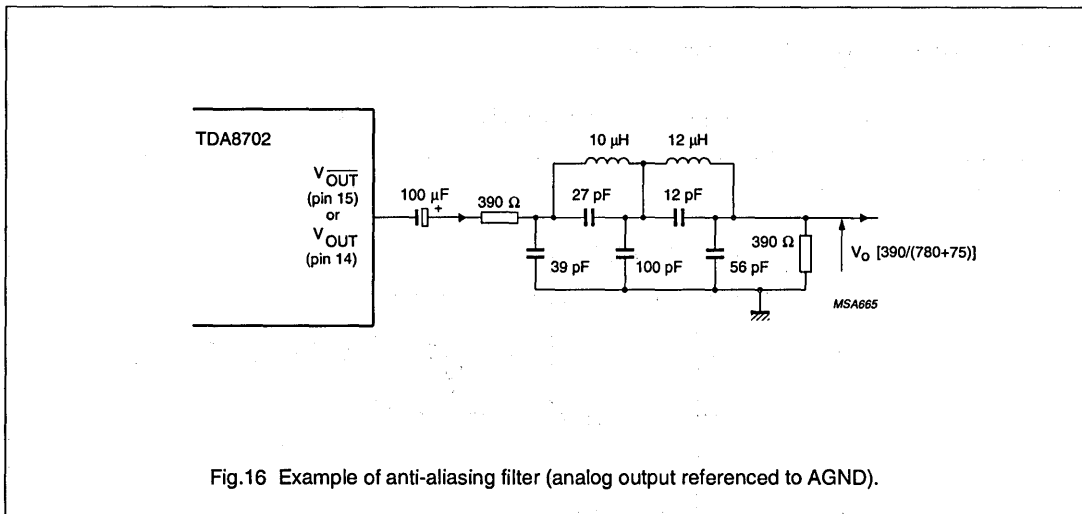
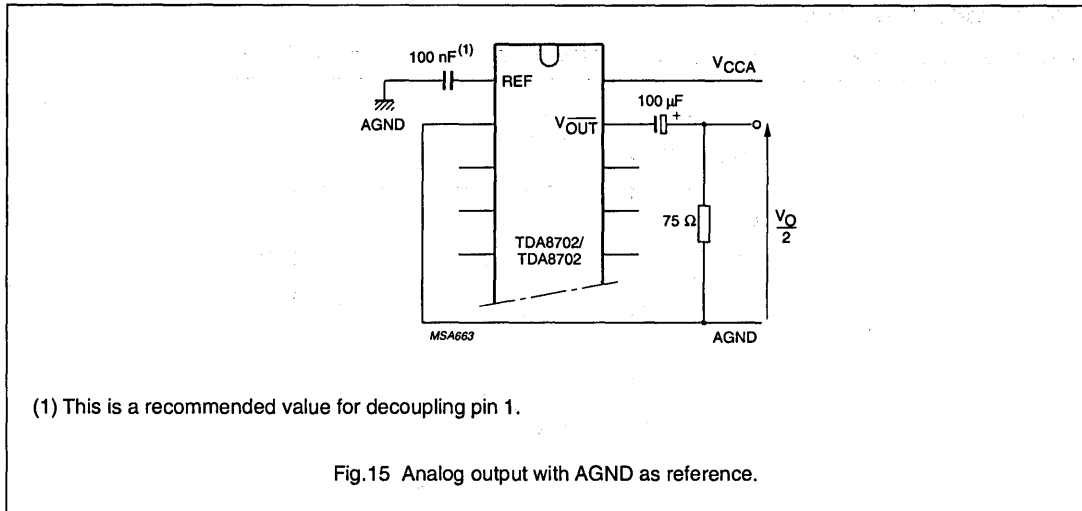



8-bit video digital-to-analog converter

TDA8702

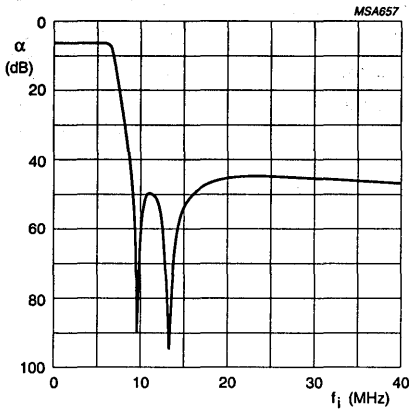

Characteristics

- Order 5; adapted CHEBYSHEV
- Ripple at  $\leq 0.1$  dB
- $f_{(-3\text{ dB})} = 6.7$  MHz
- $f_{(\text{NOTCH})} = 9.7$  MHz and 13.3 MHz

Fig.17 Frequency response for filter shown in Fig.16.

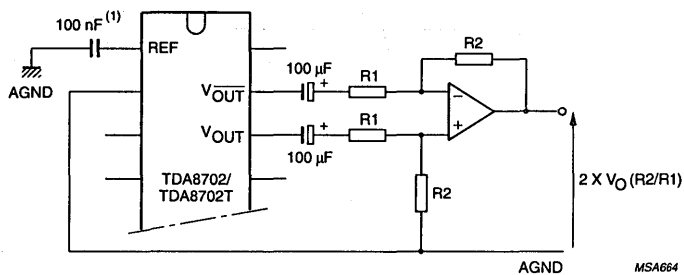

(1) This is a recommended value for decoupling pin 1.

Fig.18 Differential mode (improved supply voltage ripple rejection).

# 8-bit high-speed analog-to-digital converter

## TDA8703

### FEATURES

- 8-bit resolution
- Sampling rate up to 40 MHz
- High signal-to-noise ratio over a large analog input frequency range (7.1 effective bits at 4.43 MHz full-scale input)
- Binary or two's complement 3-state TTL outputs
- Overflow/underflow 3-state TTL output
- TTL compatible digital inputs
- Low-level AC clock input signal allowed
- Internal reference voltage generator
- Power dissipation only 290 mW (typical)
- Low analog input capacitance, no buffer amplifier required
- No sample-and-hold circuit required.

### APPLICATIONS

- General purpose high-speed analog-to-digital conversion
- Digital TV, IDTV
- Subscriber TV decoder
- Satellite TV decoders
- Digital VCR.

### GENERAL DESCRIPTION

The TDA8703 is an 8-bit high-speed analog-to-digital converter (ADC) for video and other applications. It converts the analog input signal into 8-bit binary-coded digital words at a maximum sampling rate of 40 MHz. All digital inputs and outputs are TTL compatible, although a low-level AC clock input signal is allowed.

### ORDERING INFORMATION

EXTENDED TYPE NUMBER	PACKAGE			
	PINS	PIN POSITION	MATERIAL	CODE
TDA8703	24	DIL	plastic	SOT101
TDA8703T	24	SO24	plastic	SOT137A

# 8-bit high-speed analog-to-digital converter

TDA8703

## QUICK REFERENCE DATA

SYMBOL	PARAMETER	CONDITIONS	MIN.	TYP.	MAX.	UNIT
$V_{CCA}$	analog supply voltage		4.5	5.0	5.5	V
$V_{CCD}$	digital supply voltage		4.5	5.0	5.5	V
$V_{CCO}$	output stages supply voltage		4.2	5.0	5.5	V
$I_{CCA}$	analog supply current		–	28	36	mA
$I_{CCD}$	digital supply current		–	19	25	mA
$I_{CCO}$	output stages supply current		–	11	14	mA
ILE	DC integral linearity error		–	–	±1	LSB
DLE	DC differential linearity error		–	–	±1/2	LSB
AILE	AC integral linearity error	note 1	–	–	±2	LSB
B	–3 dB bandwidth	note 2; $f_{CLK} = 40$ MHz	–	19.5	–	MHz
$f_{CLK}/\overline{f_{CLK}}$	maximum conversion rate	note 3	40	–	–	MHz
$P_{tot}$	total power dissipation		–	290	415	mW

## Notes

- Full-scale sinewave ( $f_i = 4.4$  MHz;  $f_{CLK}$ ;  $\overline{f_{CLK}} = 27$  MHz).
- The –3 dB bandwidth is determined by the 3 dB reduction in the reconstructed output (full-scale signal at input).
- The circuit has two clock inputs CLK and  $\overline{CLK}$ . There are four modes of operation:
  - TTL (mode 1);  $\overline{CLK}$  decoupled to DGND by a capacitor. CLK input is TTL threshold voltage of 1.5 V and sampling on the LOW-to-HIGH transition of the input clock signal.
  - TTL (mode 2); CLK decoupled to DGND by a capacitor.  $\overline{CLK}$  input is TTL threshold voltage of 1.5 V and sampling on the HIGH-to-LOW transition of the input clock signal.
  - AC drive modes (modes 3 and 4); When driving the CLK input directly and with any AC signal of 0.5 V (peak-to-peak value) imposed on a DC level of 1.5 V, sampling takes place on the LOW-to-HIGH transition of the clock signal. When driving the  $\overline{CLK}$  input with such a signal, sampling takes place on the HIGH-to-LOW transition.
  - If one of the clock inputs is not driven, then it is recommended to decouple this input to DGND with a 100 nF capacitor.

# 8-bit high-speed analog-to-digital converter

TDA8703

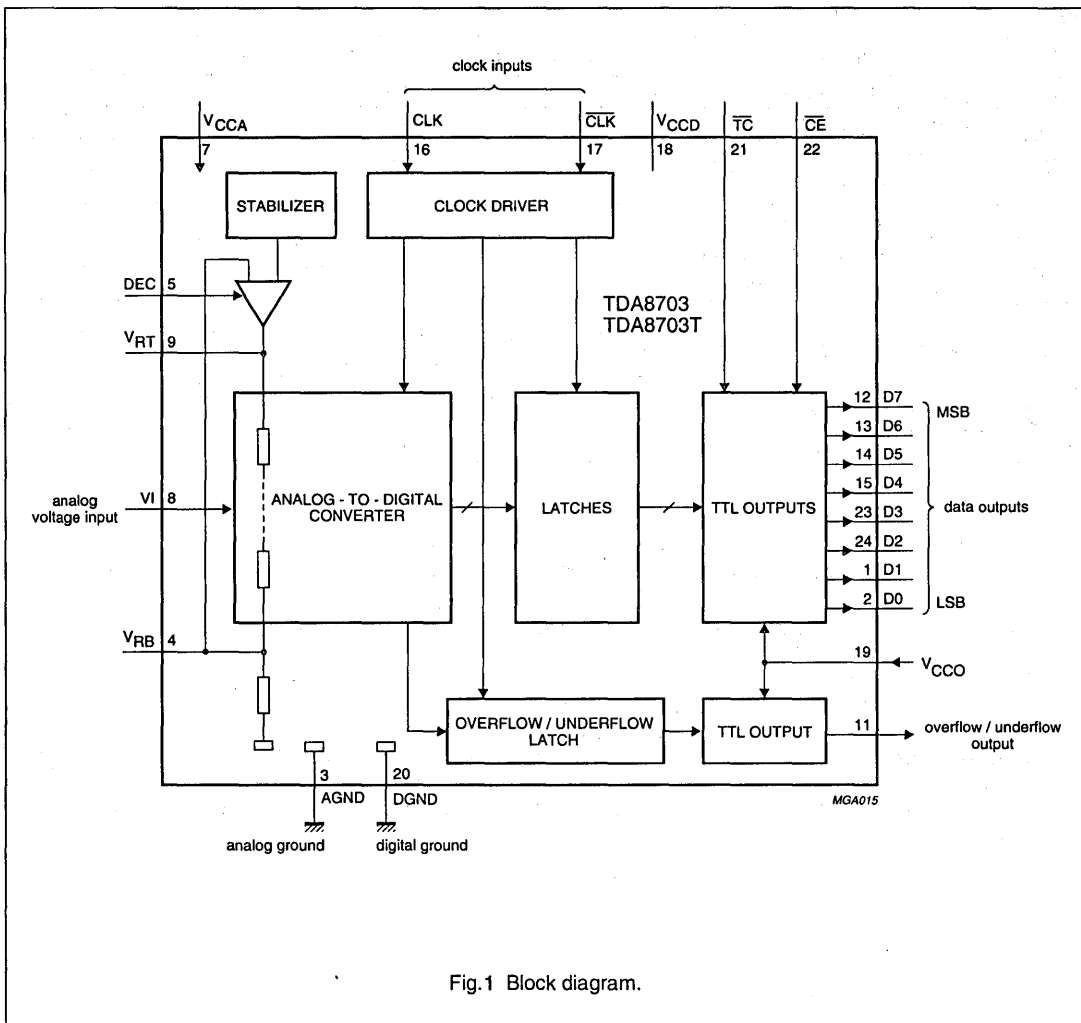

Fig.1 Block diagram.

# 8-bit high-speed analog-to-digital converter

## TDA8703

### PINNING

SYMBOL	PIN	DESCRIPTION
D1	1	data output; bit 1
D0	2	data output; bit 0 (LSB)
AGND	3	analog ground
V <sub>RB</sub>	4	reference voltage bottom (decoupling)
DEC	5	decoupling input (internal stabilization loop decoupling)
n.c.	6	not connected
V <sub>CCA</sub>	7	positive supply voltage for analog circuits (+5 V)
V <sub>I</sub>	8	analog voltage input
V <sub>RT</sub>	9	reference voltage top (decoupling)
n.c.	10	not connected
O/UF	11	overflow/underflow data output
D7	12	data output; bit 7 (MSB)
D6	13	data output; bit 6
D5	14	data output; bit 5
D4	15	data output; bit 4
CLK	16	clock input
CLK	17	complementary clock input
V <sub>CCD</sub>	18	positive supply voltage for digital circuits (+5 V)
V <sub>CCO</sub>	19	positive supply voltage for output stages (+5 V)
DGND	20	digital ground
TC	21	input for two's complement output (TTL level input, active LOW)
CE	22	chip enable input (TTL level input, active LOW)
D3	23	data output; bit 3
D2	24	data output; bit 2

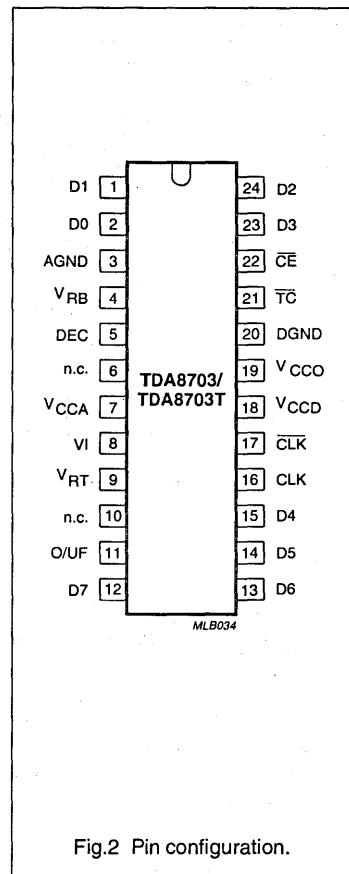

Fig.2 Pin configuration.

# 8-bit high-speed analog-to-digital converter

TDA8703

## LIMITING VALUES

In accordance with the Absolute Maximum Rating System (IEC134).

SYMBOL	PARAMETER	CONDITIONS	MIN.	MAX.	UNIT
$V_{CCA}$	analog supply voltage		-0.3	7.0	V
$V_{CCD}$	digital supply voltage		-0.3	7.0	V
$V_{CCO}$	output stages supply voltage		-0.3	7.0	V
$V_{CCA} - V_{CCD}$	supply voltage differences		-1.0	1.0	V
$V_{CCO} - V_{CCD}$	supply voltage differences		-1.0	1.0	V
$V_{CCA} - V_{CCO}$	supply voltage differences		-1.0	1.0	V
$V_{VI}$	input voltage range	referenced to AGND	-0.3	7.0	V
$V_{CLK}/\sqrt{V_{CLK}}$	AC input voltage for switching (peak-to-peak value)	note 1; referenced to DGND	-	2.0	V
$I_o$	output current		-	+10	mA
$T_{stg}$	storage temperature		-55	+150	°C
$T_{amb}$	operating ambient temperature		0	+70	°C
$T_j$	junction temperature		-	+125	°C

### Note

- The circuit has two clock inputs CLK and  $\overline{CLK}$ . There are four modes of operation:
  - TTL (mode 1); CLK decoupled to DGND by a capacitor. CLK input is TTL threshold voltage of 1.5 V and sampling on the LOW-to-HIGH transition of the input clock signal.
  - TTL (mode 2); CLK decoupled to DGND by a capacitor.  $\overline{CLK}$  input is TTL threshold voltage of 1.5 V and sampling on the HIGH-to-LOW transition of the input clock signal.
  - AC drive modes (modes 3 and 4); When driving the CLK input directly and with any AC signal of 0.5 V (peak-to-peak value) imposed on a DC level of 1.5 V, sampling takes place on the LOW-to-HIGH transition of the clock signal. When driving the  $\overline{CLK}$  input with such a signal, sampling takes place on the HIGH-to-LOW transition. If one of the clock inputs is not driven, then it is recommended to decouple this input to DGND with a 100 nF capacitor.

### THERMAL RESISTANCE

SYMBOL	PARAMETER	THERMAL RESISTANCE
$R_{th\ ja}$	from junction to ambient in free air	
	SOT101	55 K/W
	SOT137A	75 K/W

### HANDLING

Inputs and outputs are protected against electrostatic discharges in normal handling. However, to be totally safe, it is desirable to take normal precautions appropriate to handling integrated circuits.

8-bit high-speed analog-to-digital  
converter

TDA8703

**CHARACTERISTICS (see Tables 1 and 2)**

$V_{CCA} = V_7 - V_3 = 4.5 \text{ V to } 5.5 \text{ V}$ ;  $V_{CCD} = V_{18} - V_{20} = 4.5 \text{ V to } 5.5 \text{ V}$ ;  $V_{CCO} = V_{19} - V_{20} = 4.5 \text{ V to } 5.5 \text{ V}$ ; AGND and DGND shorted together;  $V_{CCA} - V_{CCD} = -0.5 \text{ V to } +0.5 \text{ V}$ ;  $V_{CCO} - V_{CCD} = -0.5 \text{ V to } +0.5 \text{ V}$ ;  $V_{CCA} - V_{CCO} = -0.5 \text{ V to } +0.5 \text{ V}$ ;  
 $T_{\text{amb}} = 0 \text{ }^\circ\text{C to } +70 \text{ }^\circ\text{C}$ ; unless otherwise specified (typical values measured at  $V_{CCA} = V_{CCD} = V_{CCO} = 5 \text{ V}$  and  $T_{\text{amb}} = 25 \text{ }^\circ\text{C}$ ).

SYMBOL	PARAMETER	CONDITIONS	MIN.	TYP.	MAX.	UNIT
<b>Supply</b>						
$V_{CCA}$	analog supply voltage		4.5	5.0	5.5	V
$V_{CCD}$	digital supply voltage		4.5	5.0	5.5	V
$V_{CCO}$	output stages supply voltage		4.2	5.0	5.5	V
$I_{CCA}$	analog supply current		–	28	36	mA
$I_{CCD}$	digital supply current		–	19	25	mA
$I_{CCO}$	output stage supply current	all outputs LOW	–	11	14	mA
<b>Inputs</b>						
Clock input $\overline{\text{CLK}}$ and CLK (note 1; referenced to DGND)						
$V_{\text{IL}}$	LOW level input voltage		0	–	0.8	V
$V_{\text{IH}}$	HIGH level input voltage		2.0	–	$V_{CCD}$	V
$I_{\text{IL}}$	LOW level input current	$V_{\text{CLK}}/\sqrt{f_{\text{CLK}}} = 0.4 \text{ V}$	–400	–	–	$\mu\text{A}$
$I_{\text{IH}}$	HIGH level input current	$V_{\text{CLK}}/\sqrt{f_{\text{CLK}}} = 0.4 \text{ V}$	–	–	100	$\mu\text{A}$
		$V_{\text{CLK}}/\sqrt{f_{\text{CLK}}} = V_{CCD}$	–	–	300	$\mu\text{A}$
$Z_{\text{i}}$	input impedance	$f_{\text{CLK}}/f_{\text{CLK}} = 10 \text{ MHz}$	–	4	–	k $\Omega$
$C_{\text{i}}$	input capacitance	$f_{\text{CLK}}/f_{\text{CLK}} = 10 \text{ MHz}$	–	4.5	–	pF
$V_{\text{CLK}} - V_{\overline{\text{CLK}}}$	AC input voltage for switching (peak-to-peak value)	note 1; DC level = 1.5 V	0.5	–	2.0	V
$\overline{\text{TC}}$ and $\overline{\text{CE}}$ (referenced to DGND)						
$V_{\text{IL}}$	LOW level input voltage		0	–	0.8	V
$V_{\text{IH}}$	HIGH level input voltage		2.0	–	$V_{CCD}$	V
$I_{\text{IL}}$	LOW level input current	$V_{\text{IL}} = 0.4 \text{ V}$	–400	–	–	$\mu\text{A}$
$I_{\text{IH}}$	HIGH level input current	$V_{\text{IH}} = 2.7 \text{ V}$	–	–	20	$\mu\text{A}$
$V_{\text{I}}$ (analog input voltage referenced to AGND)						
$V_{\text{VI(B)}}$	input voltage (bottom)		1.33	1.41	1.48	V
$V_{\text{VI(O)}}$	input voltage	output code = 0	1.455	1.55	1.635	V
$V_{\text{OS(B)}}$	offset voltage (bottom)	$V_{\text{VI(O)}} - V_{\text{VI(B)}}$	0.125	–	0.155	V
$V_{\text{VI(T)}}$	input voltage (top)		3.2	3.36	3.5	V
$V_{\text{VI(255)}}$	input voltage	output code = 255	3.115	3.26	3.385	V
$V_{\text{OS(T)}}$	offset voltage (top)	$V_{\text{VI(T)}} - V_{\text{VI(255)}}$	0.085	–	0.115	V
$V_{\text{VI(p-p)}}$	input voltage amplitude (peak-to-peak value)		1.66	1.71	1.75	V
$I_{\text{IL}}$	LOW level input current	$V_{\text{VI}} = 1.4 \text{ V}$	–	0	–	$\mu\text{A}$
$I_{\text{IH}}$	HIGH level input current	$V_{\text{VI}} = 3.6 \text{ V}$	60	120	180	$\mu\text{A}$
$Z_{\text{i}}$	input impedance	$f_{\text{i}} = 1 \text{ MHz}$	–	10	–	k $\Omega$
$C_{\text{i}}$	input capacitance	$f_{\text{i}} = 1 \text{ MHz}$	–	14	–	pF

8-bit high-speed analog-to-digital  
converter

TDA8703

## CHARACTERISTICS

SYMBOL	PARAMETER	CONDITIONS	MIN.	TYP.	MAX.	UNIT
<b>Reference resistance</b>						
$R_{ref}$	reference resistance	$V_{RT}$ to $V_{RB}$	–	220	–	$\Omega$
<b>Outputs</b>						
Digital outputs (D7 - D0) (referenced to DGND)						
$V_{OL}$	LOW level output voltage	$I_O = 1$ mA	0	–	0.4	V
$V_{OH}$	HIGH level output voltage	$I_O = -0.4$ mA	2.7	–	$V_{CCD}$	V
$I_{OZ}$	output current in 3-state mode	$0.4$ V < $V_O$ < $V_{CCD}$	–20	–	+20	$\mu$ A
<b>Switching characteristics (note 2; see Fig.3)</b>						
$f_{CLK}/\overline{f_{CLK}}$	maximum clock frequency		40	–	–	MHz
<b>Analog signal processing (<math>f_{CLK} = 40</math> MHz)</b>						
B	–3 dB bandwidth	note 3	–	19.5	–	MHz
$G_d$	differential gain	note 4	–	0.6	–	%
$\phi_d$	differential phase	note 4	–	0.8	–	deg
$f_1$	fundamental harmonics (full-scale)	$f_1 = 4.43$ MHz	–	–	0	dB
$f_{all}$	harmonics (full-scale), all components	$f_1 = 4.43$ MHz	–	–55	–	dB
SVRR1	supply voltage ripple rejection	note 5	–	–28	–25	dB
SVRR2	supply voltage ripple rejection	note 5	–	1	2.5	%/V
<b>Transfer function</b>						
ILE	DC integral linearity error		–	–	$\pm 1$	LSB
DLE	DC differential linearity error		–	–	$\pm 1/2$	LSB
AILE	AC integral linearity error	note 6	–	–	$\pm 2$	LSB
EB	effective bits	$f_1 = 4.43$ MHz	–	7.1	–	bits
<b>Timing (note 7; see Figs 3 to 6; <math>f_{CLK} = 40</math> MHz)</b>						
$t_{ds}$	sampling delay		–	–	2	ns
$t_{HD}$	output hold time		6	–	–	ns
$t_{dLH}$	output delay time	LOW-to-HIGH transition	–	8	10	ns
$t_{dHL}$	output delay time	HIGH-to-LOW transition	–	16	20	ns
$t_{dZH}$	3-state output delay times	enable-to-HIGH	–	19	25	ns
$t_{dZL}$	3-state output delay times	enable-to-LOW	–	16	20	ns
$t_{dHZ}$	3-state output delay times	disable-to-HIGH	–	14	20	ns
$t_{dLZ}$	3-state output delay times	disable-to-LOW	–	9	12	ns



## 8-bit high-speed analog-to-digital converter

TDA8703

### Notes

- The circuit has two clock inputs CLK and  $\overline{\text{CLK}}$ . There are four modes of operation:
  - TTL (mode 1); CLK decoupled to DGND by a capacitor. CLK input is TTL threshold voltage of 1.5 V and sampling on the LOW-to-HIGH transition of the input clock signal.
  - TTL (mode 2); CLK decoupled to DGND by a capacitor.  $\overline{\text{CLK}}$  input is TTL threshold voltage of 1.5 V and sampling on the HIGH-to-LOW transition of the input clock signal.
  - AC drive modes (modes 3 and 4); When driving the CLK input directly and with any AC signal of 0.5 V (peak-to-peak value) imposed on a DC level of 1.5 V, sampling takes place on the LOW-to-HIGH transition of the clock signal. When driving the  $\overline{\text{CLK}}$  input with such a signal, sampling takes place on the HIGH-to-LOW transition. If one of the clock inputs is not driven, then it is recommended to decouple this input to DGND with a 100 nF capacitor.
- In addition to a good layout of the digital and analog ground, it is recommended that the rise and fall times of the clock must not be less than 2 ns.
- The -3 dB bandwidth is determined by the 3 dB reduction in the reconstructed output (full-scale signal at the input).
- Low frequency ramp signal ( $V_{\text{VI(p-p)}} = 1.8 \text{ V}$  and  $f_i = 15 \text{ kHz}$ ) combined with a sinewave input voltage ( $V_{\text{VI(p-p)}} = 0.5 \text{ V}$ ,  $f_i = 4.43 \text{ MHz}$ ) at the input.
- Supply voltage ripple rejection:
  - SVRR1; variation of the input voltage producing output code 127 for supply voltage variation of 1 V:  

$$\text{SVRR1} = 20 \log (\Delta V_{\text{VI}(127)} / \Delta V_{\text{CCA}})$$
  - SVRR2; relative variation of the full-scale range of analog input for a supply voltage variation of 1 V:  

$$\text{SVR2} = \{ (\Delta V_{\text{VI}(0)} - V_{\text{VI}(255)}) / (V_{\text{VI}(0)} - V_{\text{VI}(255)}) \} + \Delta V_{\text{CCA}}$$
- Full-scale sinewave ( $f_i = 4.4 \text{ MHz}$ ;  $f_{\text{CLK}}; \overline{f_{\text{CLK}}} = 27 \text{ MHz}$ ).
- Output data acquisition:
  - Output data is available after the maximum delay of  $t_{\text{dHL}}$  and  $t_{\text{dLH}}$ .

# 8-bit high-speed analog-to-digital converter

TDA8703

**Table 1** Output coding and input voltage (referenced to AGND; typical values).

STEP	$V_{VI(pp)}$	O/UF	BINARY OUTPUT BITS								TWO's COMPLEMENT OUTPUT BITS							
			D7	D6	D5	D4	D3	D2	D1	D0	D7	D6	D5	D4	D3	D2	D1	D0
underflow	< 1.55	1	0	0	0	0	0	0	0	0	1	0	0	0	0	0	0	0
0	1.55	0	0	0	0	0	0	0	0	0	1	0	0	0	0	0	0	0
1	-	0	0	0	0	0	0	0	0	1	1	0	0	0	0	0	0	1
•	•	•	•	•	•	•	•	•	•	•	•	•	•	•	•	•	•	•
•	•	•	•	•	•	•	•	•	•	•	•	•	•	•	•	•	•	•
254	•	0	1	1	1	1	1	1	1	0	0	1	1	1	1	1	1	0
255	3.26	0	1	1	1	1	1	1	1	1	0	1	1	1	1	1	1	1
overflow	> 3.26	1	1	1	1	1	1	1	1	1	0	1	1	1	1	1	1	1

**Table 2** Mode selection.

$\overline{TC}$	$\overline{CE}$	D7 - D0	O/UF
X	1	high impedance	high impedance
0	0	active; two's complement	active
1	0	active; binary	active

Where: X = don't care

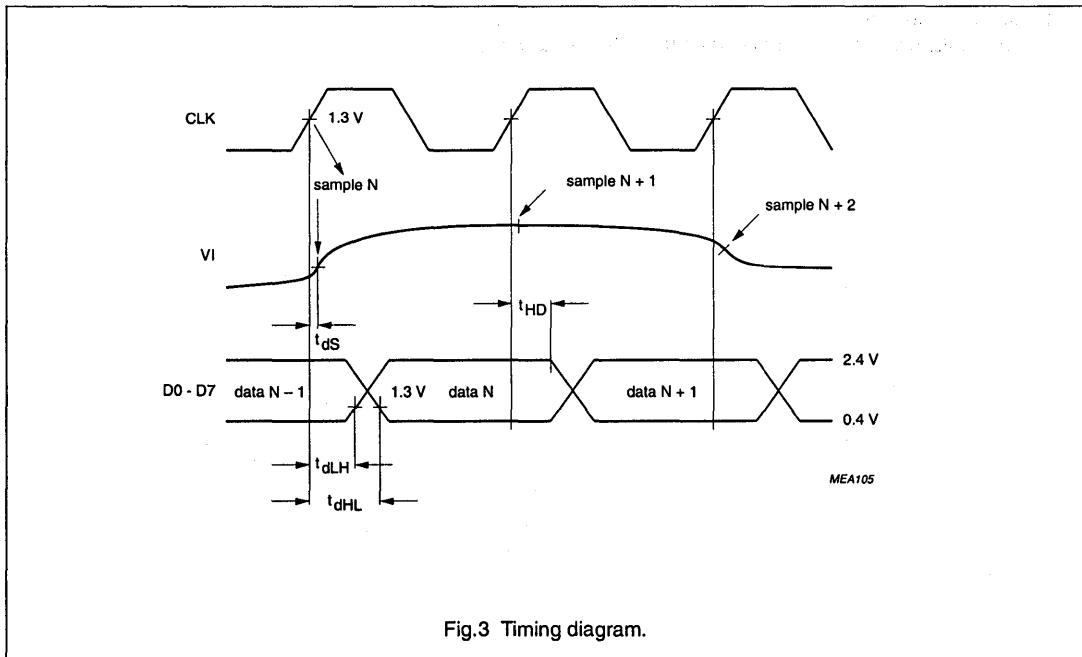

Fig.3 Timing diagram.

# 8-bit high-speed analog-to-digital converter

TDA8703

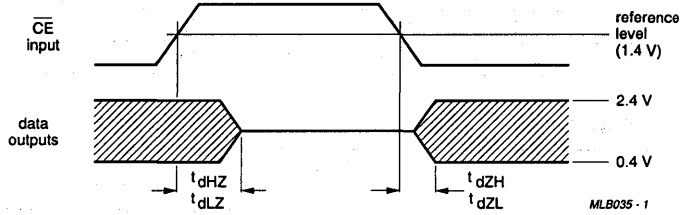

Fig.4 3-state delay timing diagram.

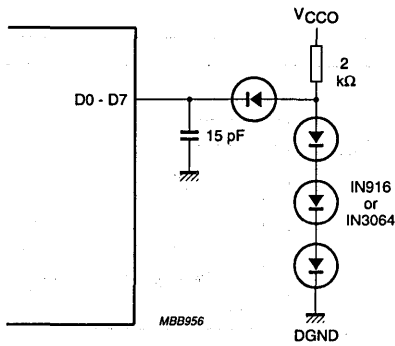

Fig.5 Load circuit for timing measurement; data outputs ( $\overline{CE} = \text{LOW}$ ).

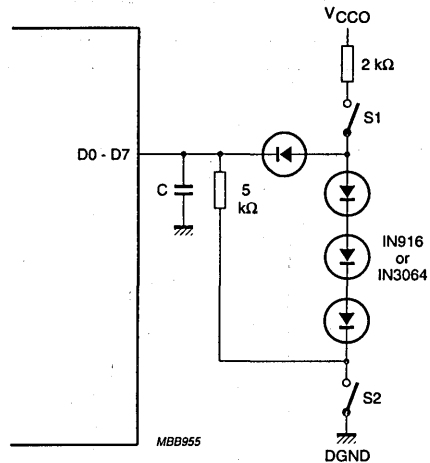

Fig.6 Load circuit for timing measurement; 3-state outputs ( $\overline{CE}$ :  $f_i = 1 \text{ MHz}$ ;  $V_{VI} = 3 \text{ V}$ ); see Table 3.

# 8-bit high-speed analog-to-digital converter

TDA8703

**Table 3** Timing measurement for load circuit.

TIMING MEASUREMENT	SWITCH S1	SWITCH S2	CAPACITOR
$t_{dZH}$	open	closed	15 pF
$t_{dZL}$	closed	open	15 pF
$t_{dHZ}$	closed	closed	5 pF
$t_{dLZ}$	closed	closed	5 pF

## INTERNAL PIN CONFIGURATIONS

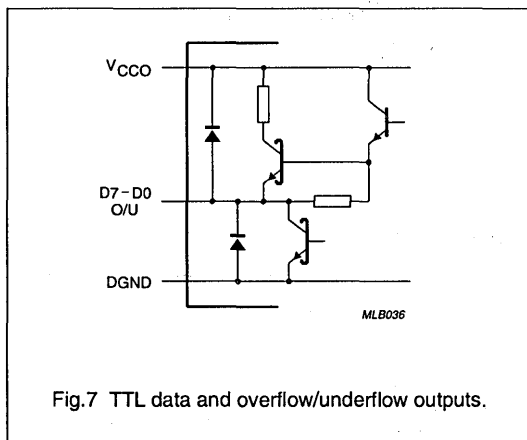

Fig.7 TTL data and overflow/underflow outputs.

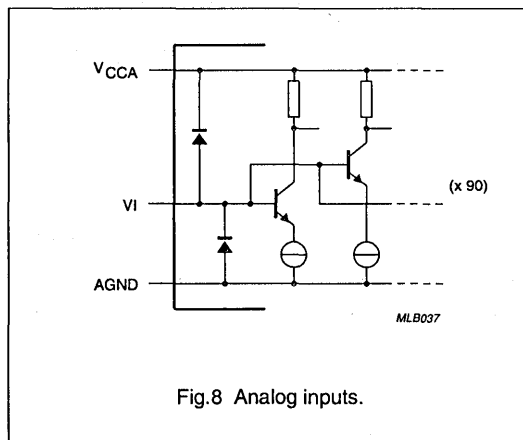

Fig.8 Analog inputs.

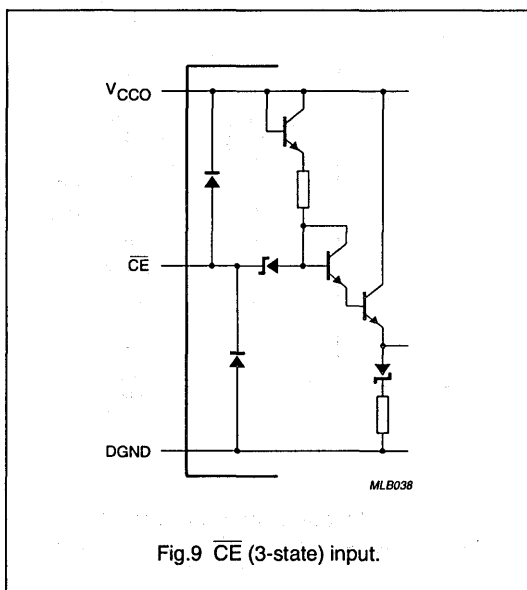

Fig.9  $\overline{CE}$  (3-state) input.

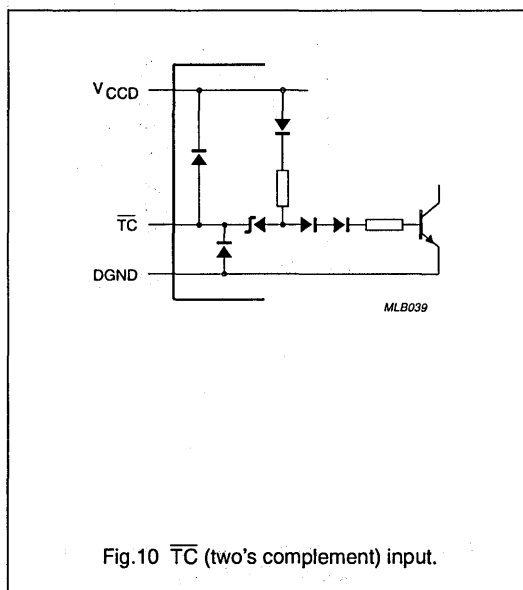

Fig.10  $\overline{TC}$  (two's complement) input.

8-bit high-speed analog-to-digital converter

TDA8703

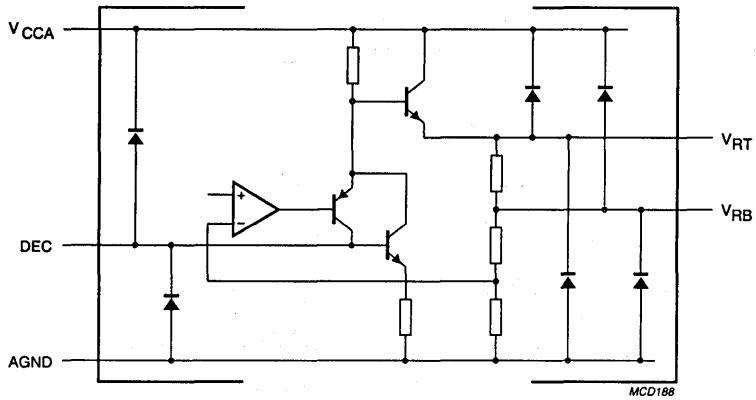

Fig.11  $V_{RB}$ ,  $V_{RT}$  and DEC.

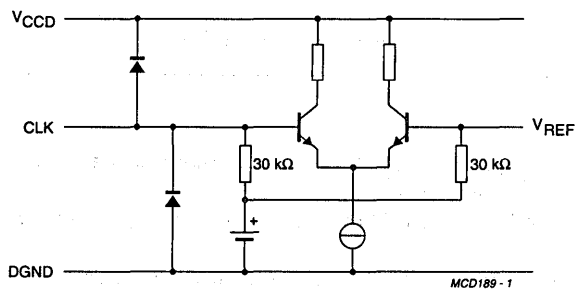

Fig.12 CLK and  $\overline{\text{CLK}}$  inputs.

# 8-bit high-speed analog-to-digital converter

## TDA8703

### APPLICATION INFORMATION

Additional application information will be supplied upon request (please quote number FTV/8901).

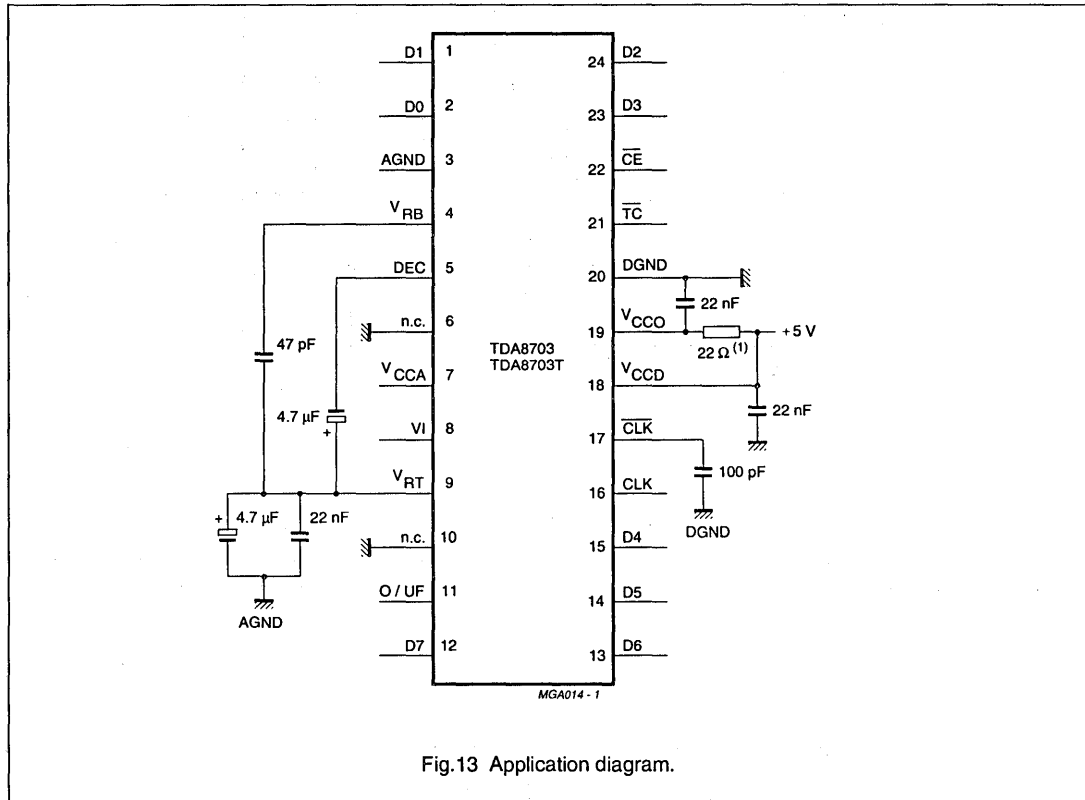

Fig.13 Application diagram.

### Notes to Fig.13

1. It is recommended to decouple  $V_{CCO}$  through a  $22\ \Omega$  resistor especially when the output data of the TDA8703 interfaces with a capacitive CMOS load device.
2. CLK should be decoupled to the DGND with a  $100\ \text{nF}$  capacitor, if a TTL signal is used on CLK (see 'Notes to the characteristics', note 1).
3. CLK and  $\overline{\text{CLK}}$  can be used in a differential mode (see 'Notes to the characteristics', note 1).
4.  $V_{RB}$  and  $V_{RT}$  are decoupling pins for the internal reference ladder; do not draw current from these pins in order to achieve good linearity.
5. If it is required to use the TDA8703 in a parallel system configuration, the references ( $V_{RB}$  and  $V_{RT}$ ) of each TDA8703 can be connected together. Code 0 will be identical and code 255 will remain in the 1LSB variation for each TDA8703.
6. Analog and digital supplies should be separated and decoupled.
7. Pins 6 and 10 should be connected to AGND in order to prevent noise influence.

# 6-bit analog-to-digital converter with multiplexer and clamp

TDA8706

## FEATURES

- 6-bit resolution
- Binary 3-state TTL outputs
- TTL compatible digital inputs
- 3 multiplexed video inputs
- Luminance and colour difference clamps
- Internal reference
- 300 mW power dissipation
- 20-pin plastic package

## APPLICATIONS

- General purpose video applications
- Y, U and V signals
- Colour Picture-in-Picture (PIPCO) for TV
- Videophone
- Frame grabber

## GENERAL DESCRIPTION

The TDA8706 is a monolithic bipolar 6-bit analog-to-digital converter (ADC) with a 3 analog input multiplexer and a clamp. All digital inputs and outputs are TTL compatible. Regulator with good temperature compensation.

## FUNCTIONAL DESCRIPTION

The TDA8706 is a "like-flash" converter which produces an output code in one clock period. The device can withstand a duty clock cycle of 50 to 66.6% (clock HIGH). Luminance clamping level is fitted with 00 hex. code (output 000000). Chrominance clamping level is fitted with 20 Hex. code (output 100000).

## QUICK REFERENCE DATA

Measured over full voltage and temperature ranges

SYMBOL	PARAMETER	CONDITIONS	MIN.	TYP.	MAX.	UNIT
$V_{CCA}$	analog supply voltage (pin 2)		4.5	5.0	5.5	V
$V_{CCD}$	digital supply voltage (pin 10)		4.5	5.0	5.5	V
$I_{CCA}$	analog supply current (pin 20)		–	32	39	mA
$I_{CCD}$	digital supply current (pin 10)		–	28	37	mA
ILE	integral linearity error		–	–	±0.75	LSB
DLE	DC differential linearity error		–	–	±0.5	LSB
$f_{CLK}$	maximum clock frequency		20	–	–	MHz
$P_{tot}$	total power dissipation		–	300	418	mW
$T_{amb}$	operating ambient temperature range		0	–	+70	°C

## ORDERING INFORMATION

EXTENDED TYPE NUMBER	PACKAGE			
	PINS	PIN POSITION	MATERIAL	CODE
TDA8706	20	DIL	plastic	SOT146EF4
TDA8706T	20	SO20L	plastic	SOT163AG7

6-bit analog-to-digital converter  
with multiplexer and clamp

TDA8706

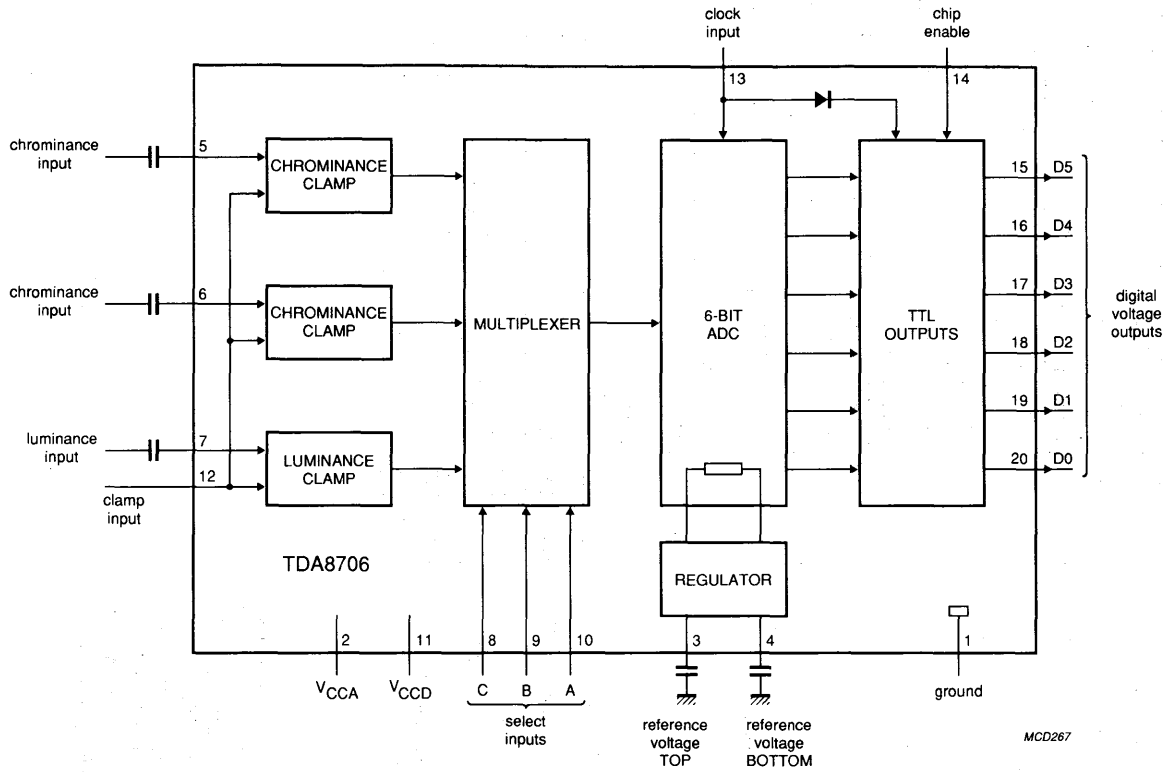

Fig.1 Block diagram.



# 6-bit analog-to-digital converter with multiplexer and clamp

TDA8706

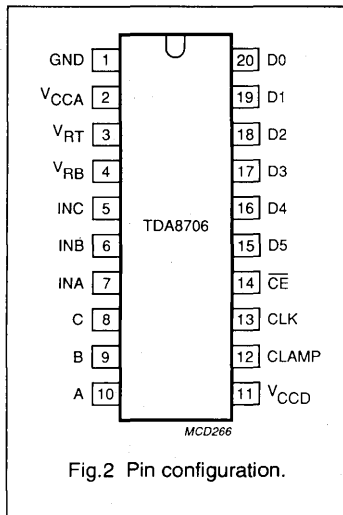

Fig.2 Pin configuration.

## PINNING

SYMBOL	PIN	DESCRIPTION
GND	1	ground
V <sub>CCA</sub>	2	analog positive supply (+5 V)
V <sub>RT</sub>	3	reference voltage TOP decoupling
V <sub>RB</sub>	4	reference voltage BOTTOM decoupling
INC	5	chrominance input
INB	6	chrominance input
INA	7	luminance input
C	8	select input
B	9	select input
A	10	select input
V <sub>CCD</sub>	11	digital positive supply voltage (+5 V)
CLAMP	12	clamp pulse input (positive pulse)
CLK	13	clock input
CE	14	chip enable (active LOW)
D5	15	digital voltage output: most significant bit (MSB)
D4	16	digital voltage output
D3	17	digital voltage output
D2	18	digital voltage output
D1	19	digital voltage output
D0	20	digital voltage input: least significant bit (LSB)

## HANDLING

Inputs and outputs are protected against electrostatic discharges in normal handling. However, to be totally safe, it is desirable to take normal precautions appropriate to handling integrated circuits.

## LIMITING VALUES

In accordance with the Absolute Maximum System (IEC 134)

SYMBOL	PARAMETER	MIN.	MAX.	UNIT
V <sub>CCA</sub>	analog supply voltage range (pin 2)	-0.3	7.0	V
V <sub>CCD</sub>	digital supply voltage range (pin 10)	-0.3	7.0	V
V <sub>CCA</sub> -V <sub>CCD</sub>	supply voltage difference	1.0	-	V
V <sub>I</sub>	input voltage range	-0.3	7.0	V
I <sub>O</sub>	output current	-	10	mA
T <sub>stg</sub>	storage temperature range	-55	+150	°C
T <sub>amb</sub>	operating ambient temperature range	0	+70	°C

# 6-bit analog-to-digital converter with multiplexer and clamp

TDA8706

**CHARACTERISTICS (see Tables 1 and 2)**

$V_{CCA} = 4.5 \text{ V to } 5.5 \text{ V}$ ;  $V_{CCD} = 4.5 \text{ V to } 5.5 \text{ V} = V_{CCD}$ ;  $T_{amb} = 0 \text{ }^\circ\text{C to } +70\text{ }^\circ\text{C}$ ;  $C_{VRB} = C_{VR1} = 100 \text{ nF}$ ; Typical values measured at  $V_{CCA} = V_{CCD} = 5 \text{ V}$  and  $T_{amb} = 25 \text{ }^\circ\text{C}$ ; unless otherwise specified

SYMBOL	PARAMETER	CONDITIONS	MIN.	TYP.	MAX.	UNIT
<b>Supply</b>						
$V_{CCA}$	analog supply voltage (pin 2)		4.5	5.0	5.5	V
$V_{CCD}$	digital supply voltage (pin 10)		4.5	5.0	5.5	V
$I_{CCA}$	analog supply current (pin 2)		–	32	39	mA
$I_{CCD}$	digital supply current (pin 10)	all outputs at LOW level	–	28	37	mA
<b>Inputs</b>						
CLOCK INPUT (PIN 13)						
$V_{IL}$	LOW level input voltage		0	–	0.8	V
$V_{IH}$	HIGH level input voltage		2.0	–	$V_{CCD}$	V
$I_{IL}$	LOW level input current	$V_{CLK} = 0.4 \text{ V}$	–400	–	–	$\mu\text{A}$
$I_{IH}$	HIGH level input current	$V_{CLK} = 2.7 \text{ V}$	–	–	100	$\mu\text{A}$
$Z_i$	input impedance	$f_{CLK} = 20 \text{ MHz}$	–	4	–	$\text{k}\Omega$
$C_i$	input capacitance	$f_{CLK} = 20 \text{ MHz}$	–	2	–	pF
A, B, C, CLAMP AND CEN INPUTS (PINS 8, 9, 10, 12 AND 14)						
$V_{IL}$	LOW level input voltage		0	–	0.8	V
$V_{IH}$	HIGH level input voltage		2	–	$V_{CCD}$	V
$I_{IL}$	LOW level input current	$V_{CLK} = 0.4 \text{ V}$	–400	–	–	$\mu\text{A}$
$I_{IH}$	HIGH level input current	$V_{CLK} = 2.7 \text{ V}$	–	–	20	$\mu\text{A}$
<b>Reference voltage (pins 3 and 4)</b>						
$V_{RT}$	reference voltage TOP decoupling		3.22	3.35	3.44	V
$V_{RB}$	reference voltage BOTTOM decoupling		1.84	1.9	1.96	V
$V_{RT} - V_{RB}$	reference voltage TOP – BOTTOM decoupling		1.36	1.435	1.48	V
<b>Analog inputs INA, INB, INC (pins 7, 6 and 5)</b>						
$V_{i(p-p)}$	input voltage amplitude (peak-to-peak value)		840	900	940	mV
$Z_i$	input impedance	$f_i = 4.43 \text{ MHz}$	100	–	–	$\text{k}\Omega$
$C_{clamp}$	coupling clamp capacitance		1	10	1000	nF
<b>Analog signal processing (pins 5, 6 and 7) (<math>f_{CLK} = 20 \text{ MHz}</math>)</b>						
$f_1$	fundamental harmonics (full scale)	$f_i = 4.43 \text{ MHz}$	–	–	0	dB
$f_{all}$	harmonics (full scale); all components	$f_i = 4.43 \text{ MHz}$	–	–45	–	dB
$G_{diff}$	differential gain	note 1	–	0.4	–	%
$\phi_{diff}$	differential phase	note 1	–	1.0	–	deg
SVRR	supply voltage ripple rejection	note 2	–	–30	–	dB
<b>Outputs</b>						
DIGITAL VOLTAGE OUTPUTS (PINS 15 TO 20) (SEE TABLE 2)						
$V_{OL}$	LOW level output voltage	$I_o = 1 \text{ mA}$	0	–	0.4	V

# 6-bit analog-to-digital converter with multiplexer and clamp

TDA8706

SYMBOL	PARAMETER	CONDITIONS	MIN.	TYP.	MAX.	UNIT
$V_{OH}$	HIGH level output voltage	$I_o = 0.5 \text{ mA}$	2.7	–	$V_{CCD}$	V
$I_{OZ}$	output current in 3-state mode	$0.4 \text{ V} < V_o < V_{CCD}$	–20	–	20	$\mu\text{A}$
<b>Switching characteristics</b>						
CLOCK TIMING (SEE FIG.3)						
$f_{CLK}$	maximum clock frequency		20	–	–	MHz
$f_{mux}$	maximum multiplexing frequency		10	–	–	MHz
$t_{CLK}$	period		50	–	–	ns
	duty cycle	$CLK = V_{IH}$	45	50	66.6	%
$t_{LOW}$	LOW time	at 50%	16	–	–	ns
$t_{HIGH}$	HIGH time	at 50%	22.5	–	–	ns
$t_{CLR}$	rise time	at 10% to 90%	4	6	–	ns
$t_{CLF}$	fall time	at 90% to 10%	4	6	–	ns
<b>Select signals, Clamp, Data (see Figs 4 and 5)</b>						
$t_s$	set-up time select A, B and C		35	–	–	ns
$t_r$	rise time (A, B and C)	at 10% to 90%	4	6	–	ns
$t_f$	fall time (A, B and C)	at 90% to 10%	4	6	–	ns
$t_{CLPS}$	set-up time clamp asynchronous		0	–	–	
$t_{CLPH}$	hold time clamp asynchronous		0	–	–	
$t_{CLPP}$	clamp pulse	$C_{CLP} = 10 \text{ nF}$	–	3	–	$\mu\text{s}$
$t_d$	data output delay time		–	15	24	ns
$t_{DH}$	data hold time		12	–	–	ns
<b>Transfer function</b>						
ILE	DC integral linearity error		–	–	$\pm 0.75$	LSB
DLE	DC differential linearity error		–	–	$\pm 0.5$	LSB
AILE	AC integral linearity error	note 3	–	–	$\pm 2$	LSB
EB	effective bits	note 3	–	5.7	–	bits
<b>Timing</b>						
DIGITAL OUTPUTS						
$T_d$	3-state delay time	see Fig.6	–	16	25	ns
$T_{so}$	sampling time offset		–	2	–	ns

**Notes to the characteristics**

- Low frequency ramp signal ( $V_{VI(p-p)} = 1.8 \text{ V}$  and  $f_i = 15 \text{ kHz}$ ) combined with a sinewave input voltage ( $V_{VI(p-p)} = 0.5 \text{ V}$  and  $f_i = 4.43 \text{ MHz}$ ) at the input.
- Supply voltage ripple rejection (SVRR): variation of the input voltage produces output code 31 for a supply voltage variation of 1 V.

$$SVRR = 20 \log \frac{\Delta V_{VI(31)}}{\Delta V_{CCA}}$$

- Full-scale sinewave;  $f_i = 4.43 \text{ MHz}$ ,  $f_{CLK} = 20 \text{ MHz}$ .

# 6-bit analog-to-digital converter with multiplexer and clamp

TDA8706

Table 1 Output coding

STEP	$V_i$ (note 1)	BINARY OUTPUTS
	(TYP. value)	D5 to D0
Underflow	< 2.2 V	000000
0	2.2 V	000000
1	2.215 V	000001
.		.....
.		.....
.		.....
62	3.072 V	111110
63	3.086 V	111111
Overflow	> 3.1 V	111111

**Note**

1. With clamping capacitance.

Table 2 Mode selection

CEN	D0 to D5
1	high impedance
0	active. Binary

Table 3 Clamp input A

A	CLAMP	DIGITAL OUTPUTS	$V_{inA}$
0	1	X	2.2
1	1	0	2.2

**Note**

X = don't care.

Table 4 Clamp input B and C

B/C	CLAMP	DIGITAL OUTPUTS	$V_{inB/VinC}$
0	1	X	2.65
1	1	32	2.65

**Note**

X = don't care.

6-bit analog-to-digital converter  
with multiplexer and clamp

TDA8706

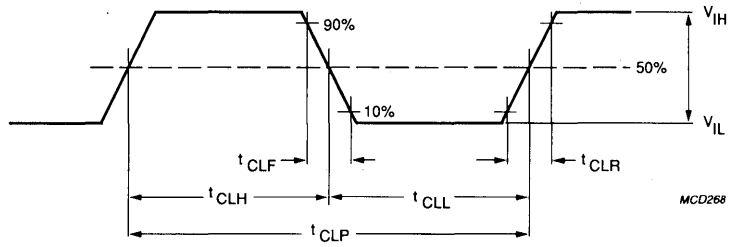

Fig.3 AC clock characteristics.

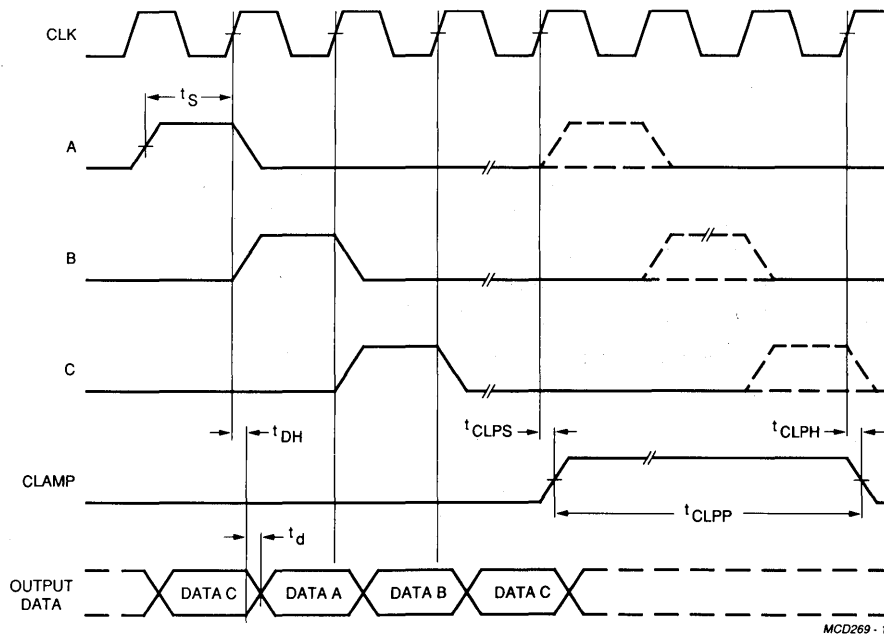

Fig.4 AC characteristics select signals; Clamp, Data.

6-bit analog-to-digital converter  
with multiplexer and clamp

TDA8706

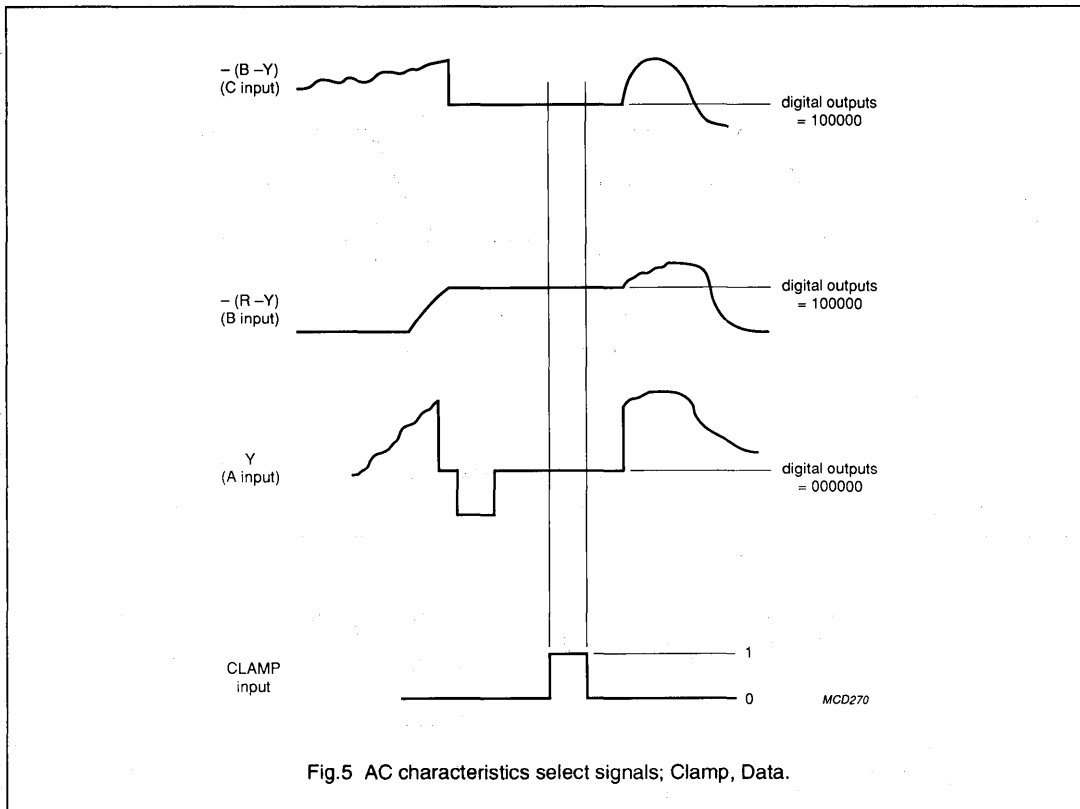

Fig.5 AC characteristics select signals; Clamp, Data.

Table 5 Clamp characteristic related to TV signals

PARAMETER	MIN.	TYP.	MAX.	UNIT
clamping time per line (signal active)	2.2	3.0	3.3	$\mu$ s
input signals clamped to correct level after	-	3	10	lines

6-bit analog-to-digital converter  
with multiplexer and clamp

TDA8706

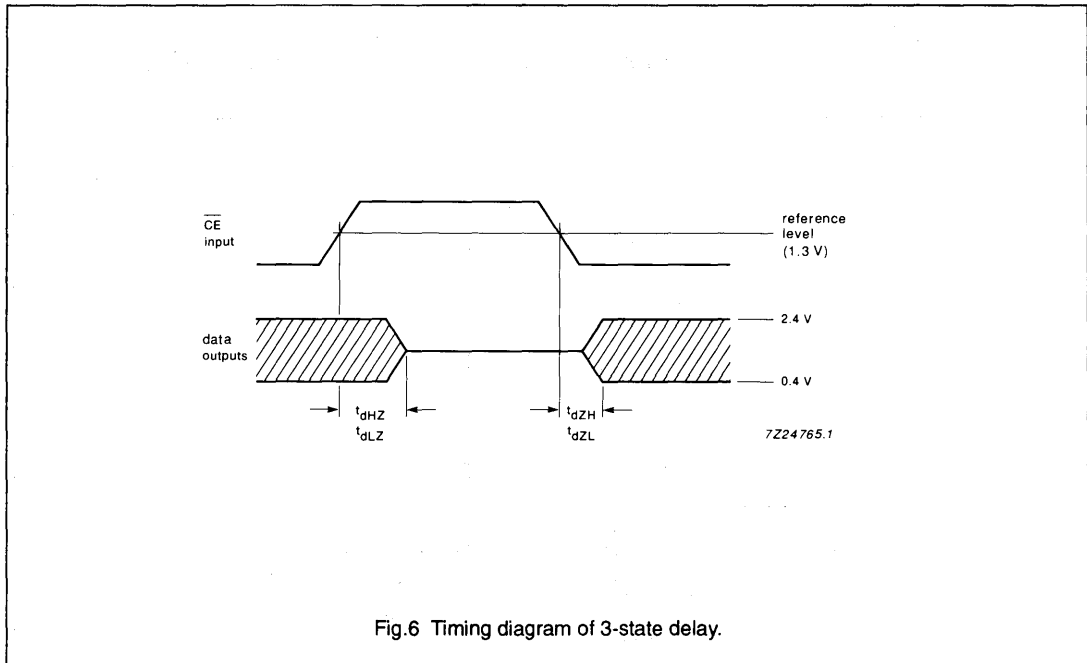

Fig.6 Timing diagram of 3-state delay.

# 6-bit analog-to-digital converter with multiplexer and clamp

TDA8706

## Application information

Additional application information will be supplied on request (please quote reference number FTV/9112).

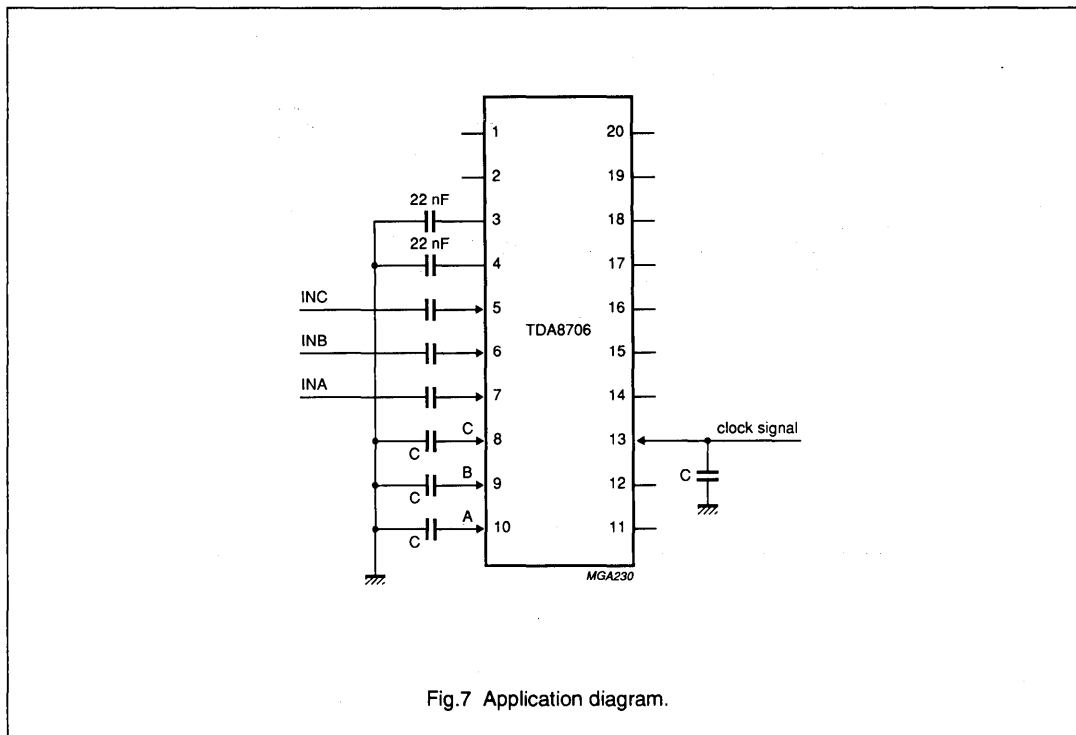

Fig.7 Application diagram.

## Notes to figure 7

1. 'C' capacitors must be determined on the output capacitance of the circuits driving A, B and C or CLK pins
2.  $V_{RB}$  and  $V_{RT}$  are decoupling pins for the internal reference ladder. Do not draw current from these pins in order to achieve good linearity
3. Analog and digital supplies should be separated and decoupled.



## Triple RGB 6-bit video analog-to-digital interface

## TDA8707

### FEATURES

- Triple analog-to-digital converter (ADC)
- 6-bit resolution
- Sampling rate up to 35 MHz
- Power dissipation of 300 mW (typical)
- Internal clamping function.

### APPLICATIONS

- High-speed analog-to-digital conversion for video signals
- VGA signal treatment.

### DESCRIPTION

The TDA8707 is a CMOS triple 6-bit video low-power analog-to-digital converter (ADC) for RGB signals. It converts the analog inputs into 6-bit binary coded digital words at a sampling rate of 35 MHz. All analog signal inputs are clamped.

### Analog-to-digital converter

The TDA8707 implements 3 independent 6-bit analog-to-digital converters in CMOS 1  $\mu\text{m}$  process. These converters use a full-flash approach.

### Clamping feature

An internal clamping circuit is provided in each of the 3 analog channels. The analog pins INR, ING and INB are switched, through series capacitors, to on-chip clamping levels during an active pulse on the clamp input CLP. Clamping level in the R, G and B channels is Code 0.

### Input buffers

Internal buffers are provided to drive the analog-to-digital converter inputs. Their ratio can be adjusted externally at 1.5 or 2.0 with select input SLT.

### QUICK REFERENCE DATA

SYMBOL	PARAMETER	CONDITIONS	MIN.	TYP.	MAX.	UNIT
$V_{DDA}$	analog supply voltage		4.5	5.0	5.5	V
$V_{DDD}$	digital supply voltage		4.5	5.0	5.5	V
$I_{DDA}$	analog supply current		–	50	–	mA
$I_{DDD}$	digital supply current		–	10	–	mA
ILE	DC integral linearity error		–	–	$\pm 0.5$	LSB
DLE	DC differential linearity error		–	–	$\pm 0.5$	LSB
EB	effective bits	note 1	–	5.3	–	bits
$f_{clk}$	maximum clock conversion rate		35	–	–	MHz
$P_{tot}$	total power dissipation	note 2	–	300	tbf	mW

### Notes

1. The number of effective bits is measured with a clock frequency of 35 MHz. This value is given for a 4.43 MHz frequency on the R, G and B channels.
2. The external resistor (between  $V_{DDA}$  and CLREF), fixing internal static currents, influences  $P_{tot}$ . Its value should be 15 k $\Omega$ .

### ORDERING INFORMATION

TYPE NUMBER	PACKAGE			
	PINS	PIN POSITION	MATERIAL	CODE
TDA8707H	44	QFP	plastic	SOT307B

# Triple RGB 6-bit video analog-to-digital interface

TDA8707

## BLOCK DIAGRAM

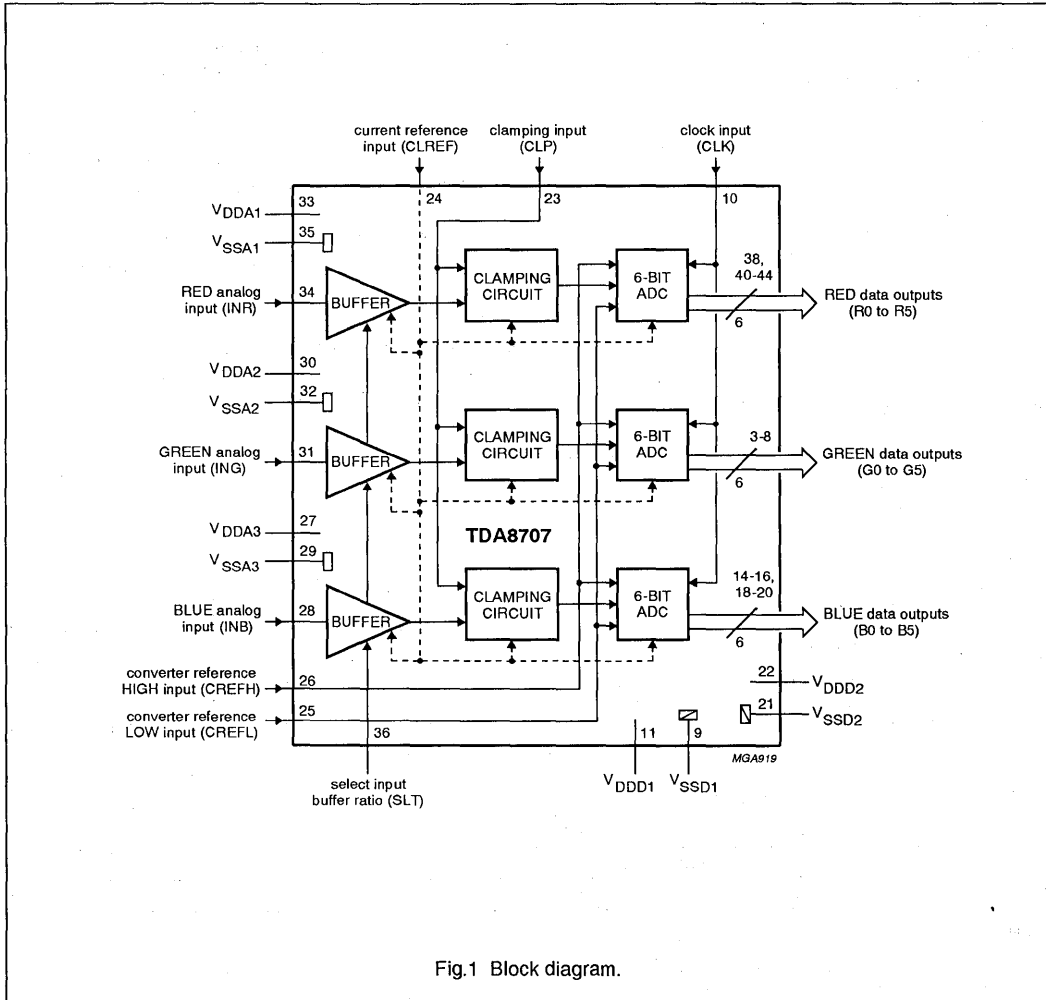

Fig.1 Block diagram.

# Triple RGB 6-bit video analog-to-digital interface

TDA8707

**PINNING**

SYMBOL	PIN	DESCRIPTION
n.c.	1	not connected
n.c.	2	not connected
G0	3	GREEN data output; bit 0 (LSB)
G1	4	GREEN data output; bit 1
G2	5	GREEN data output; bit 2
G3	6	GREEN data output; bit 3
G4	7	GREEN data output; bit 4
G5	8	GREEN data output; bit 5 (MSB)
V <sub>SSD1</sub>	9	digital supply ground 1
CLK	10	clock input
V <sub>DD1</sub>	11	digital supply voltage 1
n.c.	12	not connected
n.c.	13	not connected
B0	14	BLUE data output; bit 0 (LSB)
B1	15	BLUE data output; bit 1
B2	16	BLUE data output; bit 2
n.c.	17	not connected
B3	18	BLUE data output; bit 3
B4	19	BLUE data output; bit 4
B5	20	BLUE data output; bit 5 (MSB)
V <sub>SSD2</sub>	21	digital supply ground 2
V <sub>DD2</sub>	22	digital supply voltage 2
CLP	23	clamping input
CLREF	24	current reference level input for ADCs
CREFL	25	converter reference LOW level input
CREFH	26	converter reference HIGH level input
V <sub>DDA3</sub>	27	analog supply voltage 3
INB	28	BLUE analog input
V <sub>SSA3</sub>	29	analog supply ground 3
V <sub>DDA2</sub>	30	analog supply voltage 2
ING	31	GREEN analog input
V <sub>SSA2</sub>	32	analog supply ground 2
V <sub>DDA1</sub>	33	analog supply voltage 1
INR	34	RED analog input
V <sub>SSA1</sub>	35	analog supply ground 1
SLT	36	select input buffer ratio
n.c.	37	not connected
R0	38	RED data output; bit 0 (LSB)
n.c.	39	not connected
R1	40	RED data output; bit 1

Triple RGB 6-bit video analog-to-digital interface

TDA8707

SYMBOL	PIN	DESCRIPTION
R2	41	RED data output; bit 2
R3	42	RED data output; bit 3
R4	43	RED data output; bit 4
R5	44	RED data output; bit 5 (MSB)

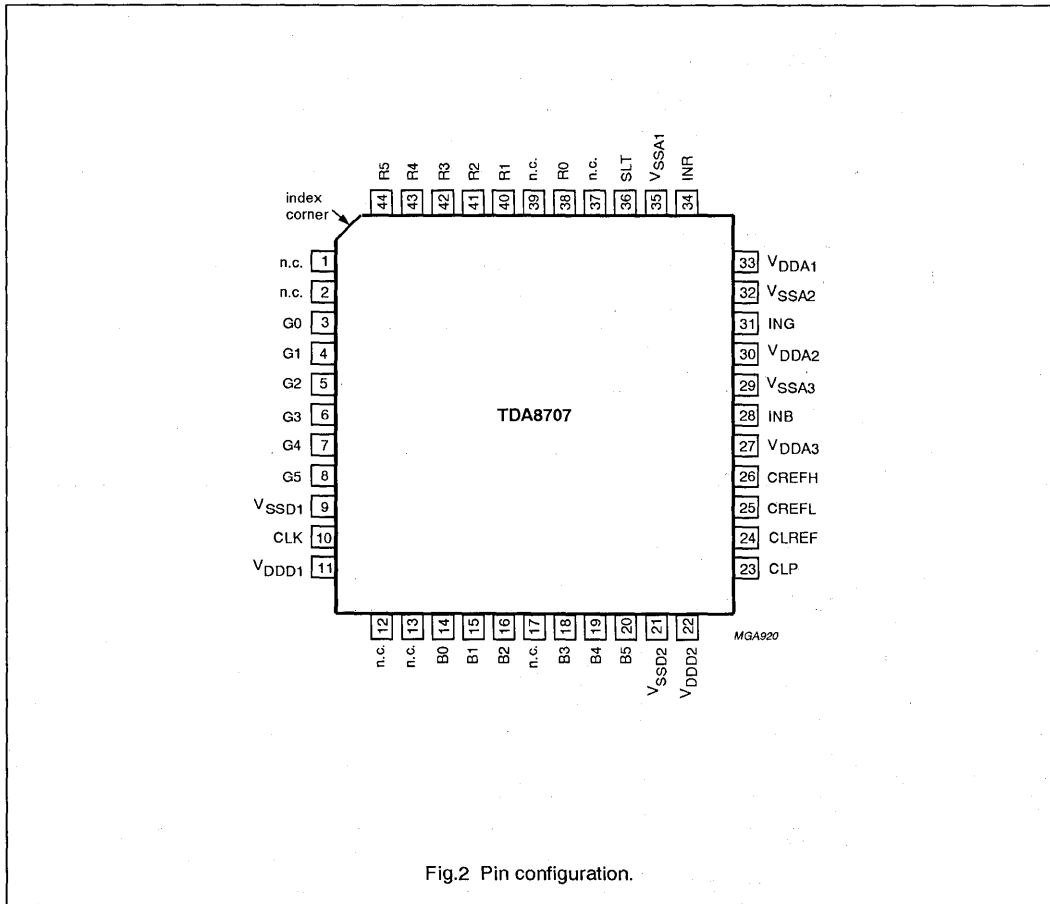

Fig.2 Pin configuration.

# Triple RGB 6-bit video analog-to-digital interface

TDA8707

## LIMITING VALUES

In accordance with the Absolute Maximum Rating System (IEC134).

SYMBOL	PARAMETER	CONDITIONS	MIN.	MAX.	UNIT
$V_{DDA}$	analog supply voltage (pins 27, 30 and 33)		-0.3	+6.5	V
$V_{DDD}$	digital supply voltage (pins 11 and 22)		-0.3	+6.5	V
$\Delta V_{DD}$	supply voltage difference between $V_{DDA}$ and $V_{DDD}$		-0.5	+0.5	V
$V_I$	input voltage (pins 28, 31 and 34)	referenced to $V_{SSA}$	-	$V_{DDA}$	V
$V_{i(p-p)}$	AC input voltage for switching (pins 10 and 23; peak-to-peak value)	referenced to $V_{SSD}$	-	$V_{DDD}$	V
$T_{stg}$	storage temperature		-55	+150	°C
$T_{amb}$	operating ambient temperature		0	+70	°C

## THERMAL CHARACTERISTICS

SYMBOL	PARAMETER	THERMAL RESISTANCE
$R_{th\ j-a}$	thermal resistance from junction to ambient in free air	75 K/W

## HANDLING

Inputs and outputs are protected against electrostatic discharges in normal handling. However, to be totally safe, it is desirable to take normal precautions appropriate to handling integrated circuits.

# Triple RGB 6-bit video analog-to-digital interface

TDA8707

## CHARACTERISTICS (see Tables 1 and 2)

$V_{DDA} = V_{DDD} = 4.5 \text{ V to } 5.5 \text{ V}$ ;  $V_{SSA}$  and  $V_{SSD}$  shorted together;  $V_{DDA} - V_{DDD} = -0.5 \text{ V to } +0.5 \text{ V}$ ;  $T_{amb} = 0 \text{ to } +70 \text{ }^\circ\text{C}$ ;  $SLT = 0 \text{ V}$ ;  $CREFH = 2.0 \text{ V}$ ,  $CREFL = 0.5 \text{ V}$ ; typical values measured at  $V_{DDA} = V_{DDD} = 5 \text{ V}$ ;  $V_{SSA} = V_{SSD} = 0 \text{ V}$  and  $T_{amb} = 25 \text{ }^\circ\text{C}$ ; unless otherwise specified.

SYMBOL	PARAMETER	CONDITIONS	MIN.	TYP.	MAX.	Unit
<b>Supply</b>						
$V_{DDA}$	analog supply voltage	note 1	4.5	5.0	5.5	V
$V_{DDD}$	digital supply voltage	note 1	4.5	5.0	5.5	V
$I_{DDA}$	analog supply current	note 2	–	50	tbf	mA
$I_{DDD}$	digital supply current	$f_{clk} = 35 \text{ MHz}$	–	10	tbf	mA
<b>Inputs</b>						
DIGITAL INPUTS (CLK: PIN 10 AND CLP: PIN 23)						
$V_{IL}$	LOW level input voltage		0	–	0.8	V
$V_{IH}$	HIGH level input voltage		2.0	–	$V_{DDD}$	V
$I_{LI}$	input leakage current		–10	–	+10	$\mu\text{A}$
$C_I$	input capacitance		–	7	–	pF
CLAMP AND REFERENCES (CLREF: PIN 24, CREFL: PIN 25 AND CREFH: PIN 26)						
$A_{CL}$	clamping accuracy		–	$\pm 0.5$	–	LSB
$I_{CL}$	input clamping current		–200	–	+400	$\mu\text{A}$
$C_{CL}$	external series clamping capacitor		10	22	–	nF
$R_{CLREF}$	external resistor on CLREF pin for current reference of converter	note 2	12	15	–	k $\Omega$
$V_{REFH}$	converter reference voltage HIGH level applied to CREFH pin	referenced to $V_{SSA}$	1.5	2.0	2.5	V
$V_{REFL}$	converter reference voltage LOW level applied to CREFL pin	referenced to $V_{SSA}$	0.25	0.5	0.75	V
$\Delta_{REF}$	reference voltage difference between $V_{REFH}$ and $V_{REFL}$	note 3	–	1.5	–	V
$Z_{CREFL}$	internal ladder impedance between pins CREFH and CREFL		–	300 (300)	–	$\Omega$
ANALOG INPUTS (INR: PIN 34, ING: PIN 31 AND INB: PIN 28)						
$V_{I(p-p)}$	full-range input voltage (peak-to-peak value)	SLT = logic 0; gain = 1.5; note 4	–	1.0	–	V
		SLT = logic 1; gain = 2.0; note 4	–	0.75	–	V
$I_I$	input current	clamp off	–	5	100	nA
$C_I$	input capacitance		–	7	15	pF
$\alpha_{CT}$	crosstalk between INR, ING and INB		–	–	–40	dB
INPUT ISOLATION						
<b>Outputs (R0 to R5: pins 38 and 40 to 44; G0 to G5: pins 3 to 8; B0 to B5: pins 14 to 16 and 18 to 20)</b>						
$V_{OL}$	LOW level output voltage		0	–	tbf	V
$V_{OH}$	HIGH level output voltage		tbf	–	$V_{DDD}$	V

Triple RGB 6-bit video analog-to-digital  
interface

TDA8707

SYMBOL	PARAMETER	CONDITIONS	MIN.	TYP.	MAX.	Unit
<b>Analog signal processing (see Fig.5)</b>						
$G_{diff}$	differential gain	note 5	-	tbf	-	%
$\varphi_{diff}$	differential phase	note 5	-	tbf	-	deg
$f_1$	fundamental harmonic	note 6	-	-	0	dB
$f_{all}$	harmonics, all components	note 6	-	-32	-	dB
<b>Transfer function (50% duty factor)</b>						
ILE	DC integral linearity error		-	-	$\pm 0.5$	LSB
DLE	DC differential linearity error		-	-	$\pm 0.5$	LSB
AILE	AC integral linearity error	note 7	-	-	$\pm 1.0$	LSB
EB	effective bits	note 8	-	5.3	-	bits
<b>Timing (see Fig.3, 4 and 6)</b>						
$f_{clk(max)}$	maximum clock frequency		35	-	-	MHz
$t_{CPH}$	clock pulse width HIGH		11	-	-	ns
$t_{CPL}$	clock pulse width LOW		11	-	-	ns
$t_{dS}$	sampling delay time		-	tbf	-	ns
$t_h$	output hold time		6	-	-	ns
$t_d$	output delay time	note 9	-	-	16	ns
$t_r$	clock rise time		3	5	-	ns
$t_f$	clock fall time		3	5	-	ns
$t_{CLP}$	active clamping duration		3	4	-	$\mu$ s

**Notes**

- $V_{DDA}$  and  $V_{DDD}$  should be supplied from the same power supply and decoupled separately.
- The analog supply current is directly proportional to the series resistance between  $V_{DDA}$  and CLREF.
- CREFH and CREFL are connected respectively to the top and bottom reference ladders of the 3 analog-to-digital converters.
- $V_{I(p-p)} = (V_{REFL} - V_{REFH})/\text{buffer gain factor}$ . See Table 2 for gain factor selection. When clamping at code 0 is used, active video signal amplitude  $V_{ACT}$  should be:

$$V_{ACT} = \frac{(V_{REFH} - V_{REFL})}{\text{buffer gain factor}}$$

- Low frequency ramp signal ( $V_{I(p-p)}$  = full scale and 64  $\mu$ s period) combined with a sine wave input voltage.  
 $V_{I(p-p)} = 0.3$  V,  $f_i$  = maximum allowed input frequency; see Fig.5
- $V_{I(p-p)} = \Delta$ REF with  $f_i = 4.43$  MHz.
- Full scale input sine wave;  $f_i = 4.43$  MHz,  $f_{CLK} = 35$  MHz.
- The number of effective bits is measured with a clock frequency of 35 MHz. This value is given for a 4.43 MHz input frequency.
- Output data acquisition: output data is available after the maximum delay time of  $t_d$ .

# Triple RGB 6-bit video analog-to-digital interface

TDA8707

**Table 1** Output coding ( $V_{REFH} = 2.0\text{ V}$ ;  $V_{REFL} = 0.5\text{ V}$  referenced to  $V_{SSA}$ ,  $SLT = 0$ ; buffer ratio = 1.5).

STEP	$V_{I(p-p)}$	BINARY OUTPUT BITS					
		D5	D4	D3	D2	D1	D0
-	$<0.333 = V_{REFL}/1.5$	0	0	0	0	0	0
0	0.349	0	0	0	0	0	0
1	0.364	0	0	0	0	0	1
.	.	.	.	.	.	.	.
62	1.317	1	1	1	1	1	0
63	1.333	1	1	1	1	1	1
-	$>1.333 = V_{REFH}/1.5$	1	1	1	1	1	1

**Table 2** Mode selection.

SLT	BUFFER RATIO	$V_{I(p-p)}$ FULL SCALE
0	1.5	$(V_{REFH} - V_{REFL})/1.5$
1	2.0	$(V_{REFH} - V_{REFL})/2.0$

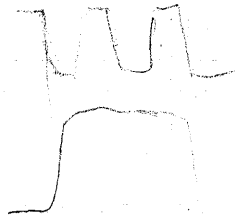



Triple RGB 6-bit video analog-to-digital interface

TDA8707

TIMING DIAGRAMS

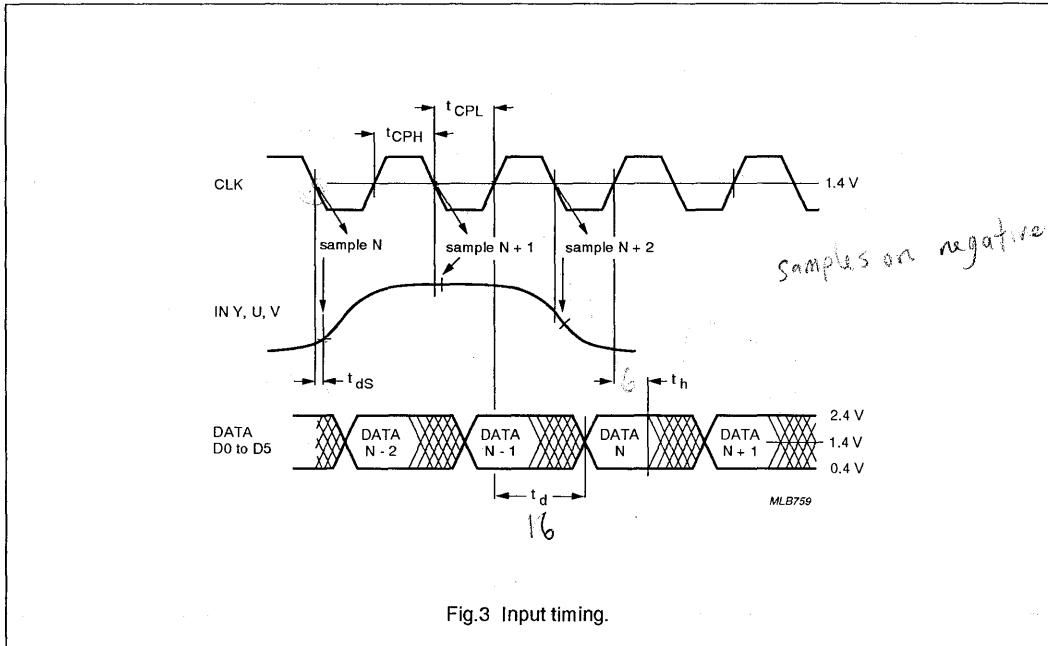

Fig.3 Input timing.

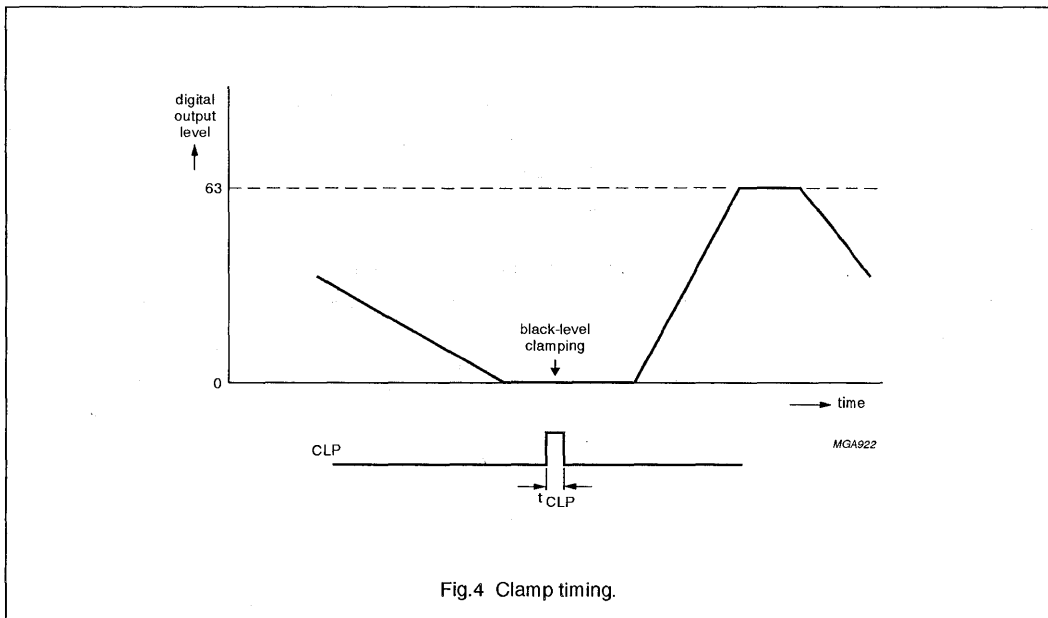
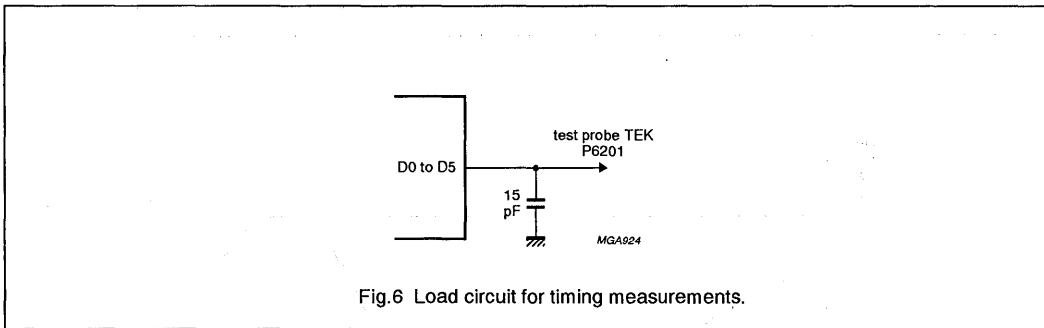
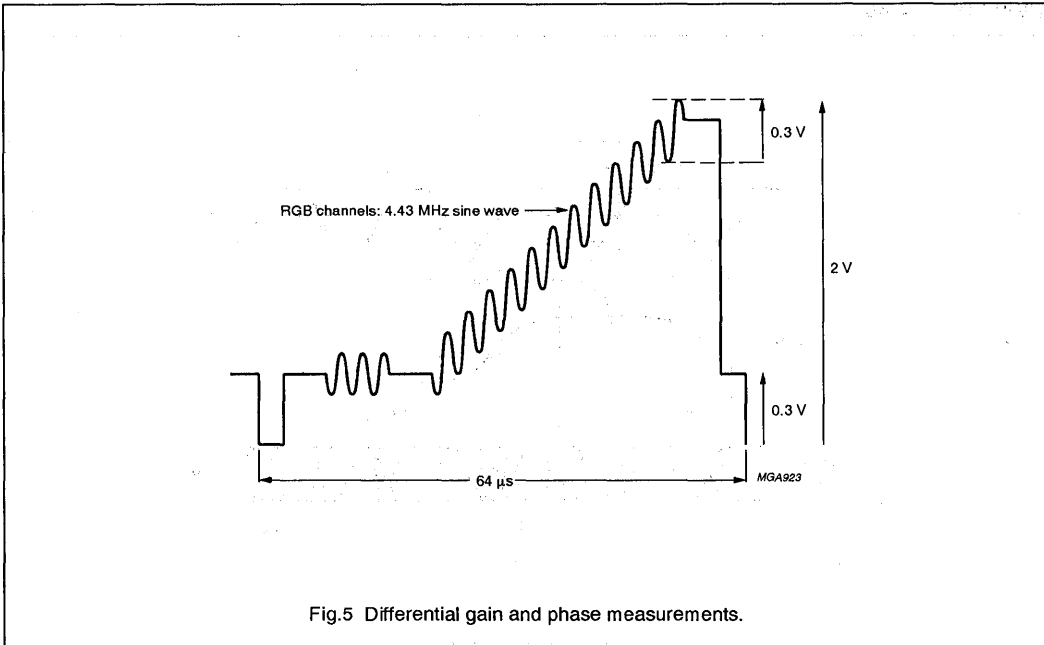

Fig.4 Clamp timing.

Triple RGB 6-bit video analog-to-digital interface

TDA8707



Triple RGB 6-bit video analog-to-digital interface

TDA8707

INTERNAL CIRCUITRY

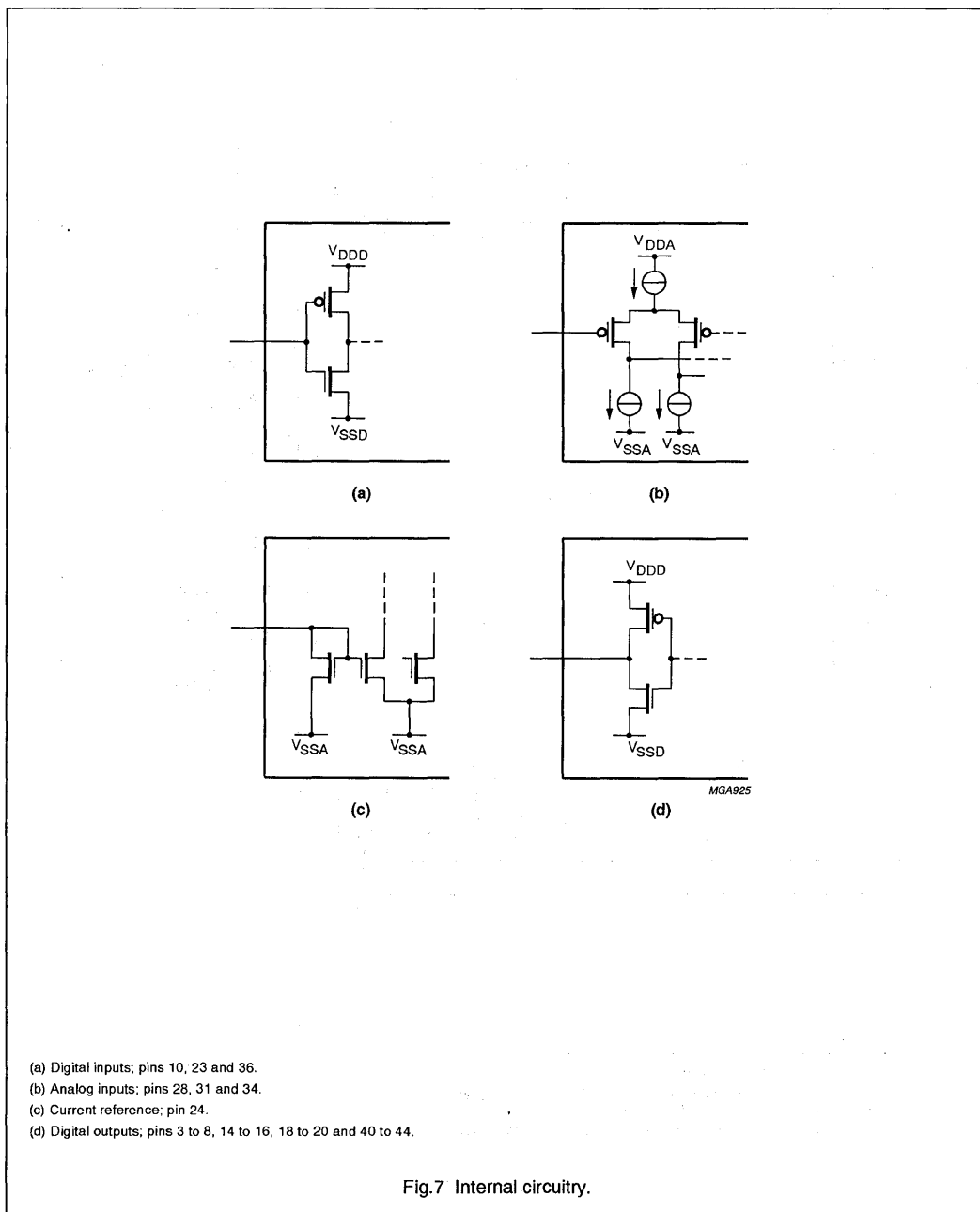

- (a) Digital inputs; pins 10, 23 and 36.
- (b) Analog inputs; pins 28, 31 and 34.
- (c) Current reference; pin 24.
- (d) Digital outputs; pins 3 to 8, 14 to 16, 18 to 20 and 40 to 44.

Fig.7 Internal circuitry.

Triple RGB 6-bit video analog-to-digital interface

TDA8707

APPLICATION INFORMATION

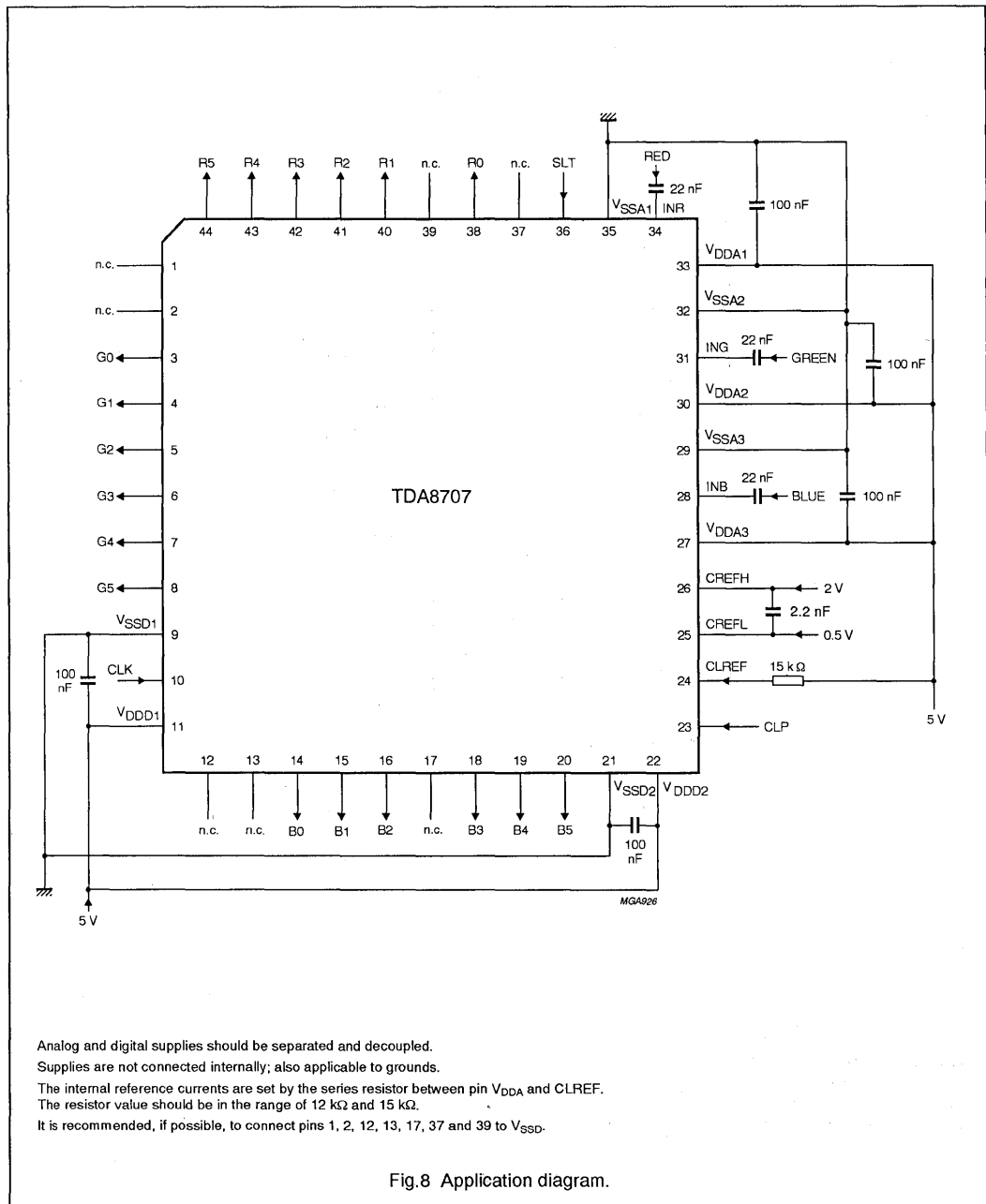

## Video analog input interface

## TDA8708A

## FEATURES

- 8-bit resolution
- Sampling rate up to 32 MHz
- Binary or two's complement 3-state TTL outputs
- TTL-compatible digital inputs and outputs
- Internal reference voltage regulator
- Power dissipation of 365 mW (typical)
- Input selector circuit (one out of three video inputs)
- Clamp and Automatic Gain Control (AGC) functions for CVBS and Y signals
- No sample-and-hold circuit required.
- The TDA8708A has white peak control in modes 1 and 2 whereas the TDA8708B has control in mode 1 only.

## APPLICATIONS

- Video signal decoding
- Scrambled TV (encoding and decoding)
- Digital picture processing
- Frame grabbing.

## GENERAL DESCRIPTION

The TDA8708A is an analog input interface for video signal processing. It includes a video amplifier with clamp and gain control, an 8-bit analog-to-digital converter (ADC) with a sampling rate of 32 MHz and an input selector.

## QUICK REFERENCE DATA

SYMBOL	PARAMETER	MIN.	TYP.	MAX.	UNIT
V <sub>CCA</sub>	analog supply voltage	4.5	5.0	5.5	V
V <sub>CCD</sub>	digital supply voltage	4.5	5.0	5.5	V
V <sub>CCO</sub>	TTL output supply voltage	4.2	5.0	5.5	V
I <sub>CCA</sub>	analog supply current	–	37	45	mA
I <sub>CCD</sub>	digital supply current	–	24	30	mA
I <sub>CCO</sub>	TTL output supply current	–	12	16	mA
ILE	DC integral linearity error	–	–	±1	LSB
DLE	DC differential linearity error	–	–	±0.5	LSB
f <sub>clk(max)</sub>	maximum clock frequency	30	32	–	MHz
B	maximum –3 dB bandwidth (AGC amplifier)	12	18	–	MHz
P <sub>tot</sub>	total power dissipation	–	365	500	mW

## ORDERING INFORMATION

TYPE NUMBER	PACKAGE			
	PINS	PIN POSITION	MATERIAL	CODE
TDA8708A	28	DIP	plastic	SOT117-1
TDA8708AT	28	SO28L	plastic	SOT136-1

Video analog input interface

TDA8708A

BLOCK DIAGRAM

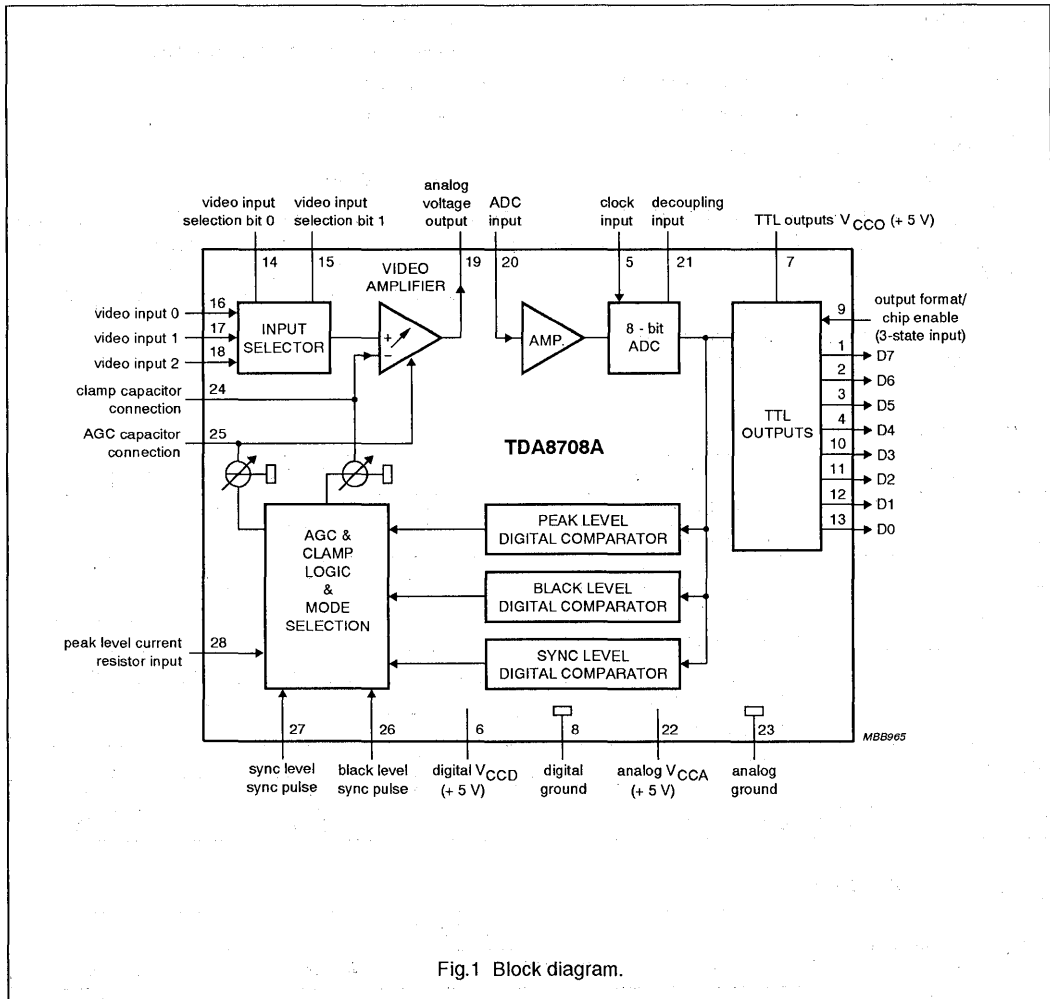

Fig.1 Block diagram.

## Video analog input interface

## TDA8708A

## PINNING

SYMBOL	PIN	DESCRIPTION
D7	1	data output; bit 7 (MSB)
D6	2	data output; bit 6
D5	3	data output; bit 5
D4	4	data output; bit 4
CLK	5	clock input
V <sub>CCD</sub>	6	digital supply voltage (+5 V)
V <sub>CCO</sub>	7	TTL outputs supply voltage (+5 V)
DGND	8	digital ground
OF	9	output format/chip enable (3-state input)
D3	10	data output; bit 3
D2	11	data output; bit 2
D1	12	data output; bit 1
D0	13	data output; bit 0 (LSB)
I0	14	video input selection bit 0
I1	15	video input selection bit 1
VIN0	16	video input 0
VIN1	17	video input 1
VIN2	18	video input 2
ANOUT	19	analog voltage output
ADCIN	20	analog-to-digital converter input
DEC	21	decoupling input
V <sub>CCA</sub>	22	analog supply voltage (+5 V)
AGND	23	analog ground
CLAMP	24	clamp capacitor connection
AGC	25	AGC capacitor connection
GATE B	26	black level synchronization pulse
GATE A	27	sync level synchronization pulse
RPEAK	28	peak level current resistor input

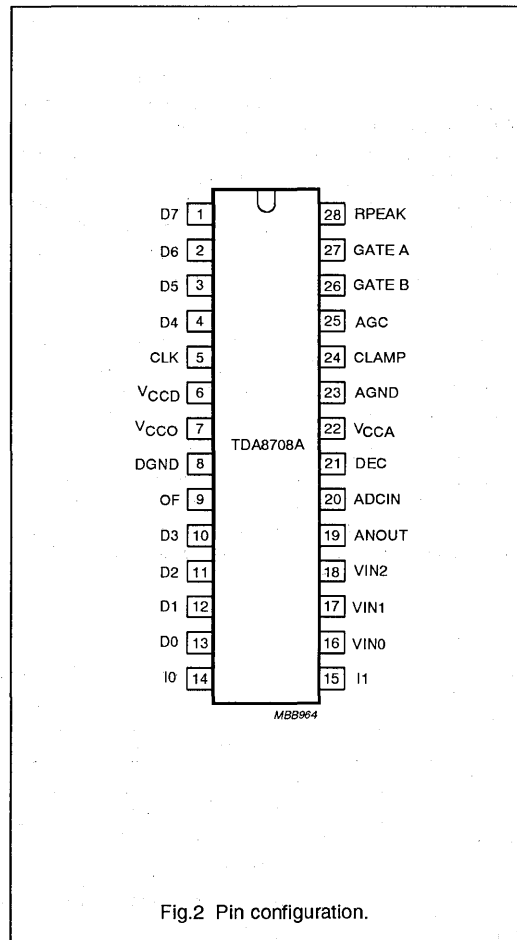

## Video analog input interface

## TDA8708A

**FUNCTIONAL DESCRIPTION**

The TDA8708A provides a simple interface for decoding video signals.

The TDA8708A operates in configuration mode 1 (see Fig. 4) when the video signals are weak (i.e. when the gain of the AGC amplifier has not yet reached its optimum value). This enables a fast recovery of the synchronization pulses in the decoder circuit. When the pulses at the GATE A and GATE B inputs become distinct (GATE A and GATE B pulses are synchronization pulses occurring during the sync period and rear porch respectively) the TDA8708A automatically switches to configuration mode 2 (see Fig. 5).

When the TDA8708A is in configuration mode 1, the gain of the AGC amplifier will be roughly adjusted (sync level to a digital output level of 0 and the peak level to a digital output level of 255).

In configuration mode 2 the digital output of the ADC is compared to internal digital reference levels. The resultant outputs control the charge or discharge current of a capacitor connected to the AGC pin. The voltage across this capacitor controls the gain of the video amplifier. This is the gain control loop.

The sync level comparator is active during a positive-going pulse at the GATE A input. This means that the sync pulse of the composite video signal is used as an amplitude reference. The bottom of the sync pulse is adjusted to obtain a digital output of logic 0 at the converter output. As the black level is at digital level 64, the sync pulse will have a digital amplitude of 64 LSBs.

The peak-white control loop is always active. If the video signal tends to exceed the digital code of 248, the gain will be limited to avoid any over-range of the converter.

The use of nominal signals will prevent the output from exceeding a digital code of 213 and the peak-white control loop will be non-active.

The clamp level control is accomplished by using the same techniques as used for the gain control. The black-level digital comparator is active during a positive-going pulse at the GATE B input. The clamp capacitor will be charged or discharged to adjust the digital output to code 64.

**LIMITING VALUES**

In accordance with the Absolute Maximum Rating System (IEC 134).

SYMBOL	PARAMETER	MIN.	MAX.	UNIT
$V_{CCA}$	analog supply voltage	-0.3	+7.0	V
$V_{CCD}$	digital supply voltage	-0.3	+7.0	V
$V_{CCO}$	output supply voltage	-0.3	+7.0	V
$\Delta V_{CC}$	supply voltage difference between $V_{CCA}$ and $V_{CCD}$	-1.0	+1.0	V
	supply voltage difference between $V_{CCO}$ and $V_{CCD}$	-1.0	+1.0	V
	supply voltage difference between $V_{CCA}$ and $V_{CCO}$	-1.0	+1.0	V
$V_I$	input voltage	-0.3	$V_{CCA}$	V
$I_O$	output current	0	+10	mA
$T_{stg}$	storage temperature	-55	+150	°C
$T_{amb}$	operating ambient temperature	0	+70	°C
$T_j$	junction temperature	0	+125	°C

**THERMAL CHARACTERISTICS**

SYMBOL	PARAMETER	VALUE	UNIT
$R_{th\ j-a}$	thermal resistance from junction to ambient in free air		
	SOT117-1	55	K/W
	SOT136-1	70	K/W



## Video analog input interface

## TDA8708A

**CHARACTERISTICS**

$V_{CCA} = V_{22}$  to  $V_{23} = 4.5$  to  $5.5$  V;  $V_{CCD} = V_6$  to  $V_8 = 4.5$  to  $5.5$  V;  $V_{CCO} = V_7$  to  $V_8 = 4.2$  to  $5.5$  V; AGND and DGND shorted together;  $V_{CCA}$  to  $V_{CCD} = -0.5$  to  $+0.5$  V;  $V_{CCO}$  to  $V_{CCD} = -0.5$  to  $+0.5$  V;  $V_{CCA}$  to  $V_{CCO} = -0.5$  to  $+0.5$  V;  $T_{amb} = 0$  to  $+70$  °C; typical readings taken at  $V_{CCA} = V_{CCD} = V_{CCO} = 5$  V and  $T_{amb} = 25$  °C; unless otherwise specified.

SYMBOL	PARAMETER	CONDITIONS	MIN.	TYP.	MAX.	UNIT
<b>Supplies</b>						
$V_{CCA}$	analog supply voltage		4.5	5.0	5.5	V
$V_{CCD}$	digital supply voltage		4.5	5.0	5.5	V
$V_{CCO}$	TTL output supply voltage		4.2	5.0	5.5	V
$I_{CCA}$	analog supply current		–	37	45	mA
$I_{CCD}$	digital supply current		–	24	30	mA
$I_{CCO}$	TTL output supply current	TTL load (see Fig.8)	–	12	16	mA
<b>Video amplifier inputs</b>						
VIN(0 TO 2) INPUTS						
$V_{I(p-p)}$	input voltage (peak-to-peak value)	AGC load with external capacitor; note 1	0.6	–	1.5	V
$ Z_i $	input impedance	$f_i = 6$ MHz	10	20	–	k $\Omega$
$C_i$	input capacitance	$f_i = 6$ MHz	–	1	–	pF
I0 AND I1 TTL INPUTS (SEE TABLE 1)						
$V_{IL}$	LOW level input voltage		0	–	0.8	V
$V_{IH}$	HIGH level input voltage		2.0	–	$V_{CCD}$	V
$I_{IL}$	LOW level input current	$V_i = 0.4$ V	–400	–	–	$\mu$ A
$I_{IH}$	HIGH level input current	$V_i = 2.7$ V	–	–	20	$\mu$ A
GATE A AND GATE B TTL INPUTS (SEE FIGS 4 AND 5)						
$V_{IL}$	LOW level input voltage		0	–	0.8	V
$V_{IH}$	HIGH level input voltage		2.0	–	$V_{CCD}$	V
$I_{IL}$	LOW level input current	$V_i = 0.4$ V	–400	–	–	$\mu$ A
$I_{IH}$	HIGH level input current	$V_i = 2.7$ V	–	–	20	$\mu$ A
$t_W$	pulse width	see Fig.5	2	–	–	$\mu$ s
RPEAK INPUT (PIN 28)						
$I_{28(min)}$	minimum peak level current	$R_{28} = 0$ $\Omega$	–	80	150	$\mu$ A
AGC INPUT (PIN 25)						
$V_{25(min)}$	AGC voltage for minimum gain		–	2.8	–	V
$V_{25(max)}$	AGC voltage for maximum gain		–	4.0	–	V
	AGC output current		see Table 2			
CLAMP INPUT (PIN 24)						
$V_{24}$	clamp voltage for code 128 output		–	3.5	–	V
$I_{24}$	clamp output current		see Table 3			

## Video analog input interface

## TDA8708A

SYMBOL	PARAMETER	CONDITIONS	MIN.	TYP.	MAX.	UNIT
<b>Video amplifier outputs</b>						
ANOUT OUTPUT (PIN 19)						
$V_{19(p-p)}$	AC output voltage (peak-to-peak value)	$V_{VIN} = 1.33 \text{ V (p-p)}$ ; $V_{25} = 3.6 \text{ V}$	–	1.33	–	V
$I_{19}$	internal current source	$R_L = \infty$	2.0	2.5	–	mA
$I_{O(p-p)}$	output current driven by the load	$V_{ANOUT} = 1.33 \text{ V (p-p)}$ ; note 2	–	–	1.0	mA
$V_{19}$	DC output voltage for black level	note 3	–	$V_{CCA} - 2.24$	–	V
$Z_{19}$	output impedance		–	20	–	$\Omega$
<b>Video amplifier dynamic characteristics</b>						
$\alpha_{ct}$	crosstalk between VIN inputs	$V_{CCA} = 4.75 \text{ to } 5.25 \text{ V}$	–	–50	–45	dB
$G_{diff}$	differential gain	$V_{VIN} = 1.33 \text{ V (p-p)}$ ; $V_{25} = 3.6 \text{ V}$	–	2	–	%
$\varphi_{diff}$	differential phase	$V_{VIN} = 1.33 \text{ V (p-p)}$ ; $V_{25} = 3.6 \text{ V}$	–	0.8	–	deg
B	–3 dB bandwidth		12	–	–	MHz
S/N	signal-to-noise ratio	note 4	60	–	–	dB
SVRR1	supply voltage ripple rejection	note 5	–	45	–	dB
$\Delta G$	gain range	see Fig.10	–4.5	–	+6.0	dB
$G_{stab}$	gain stability as a function of supply voltage and temperature	see Fig.10	–	–	5	%
<b>Analog-to-digital converter inputs</b>						
CLK INPUT (PIN 5)						
$V_{IL}$	LOW level input voltage		0	–	0.8	V
$V_{IH}$	HIGH level input voltage		2.0	–	$V_{CCD}$	V
$I_{IL}$	LOW level input current	$V_{clk} = 0.4 \text{ V}$	–400	–	–	$\mu\text{A}$
$I_{IH}$	HIGH level input current	$V_{clk} = 2.7 \text{ V}$	–	–	100	$\mu\text{A}$
$ Z_i $	input impedance	$f_{clk} = 10 \text{ MHz}$	–	4	–	k $\Omega$
$C_i$	input capacitance	$f_{clk} = 10 \text{ MHz}$	–	4.5	–	pF
OF INPUT (3-STATE; SEE TABLE 4)						
$V_{IL}$	LOW level input voltage		0	–	0.2	V
$V_{IH}$	HIGH level input voltage		2.6	–	$V_{CCD}$	V
$V_9$	input voltage in high impedance state		–	1.15	–	V
$I_{IL}$	LOW level input current		–370	–300	–	$\mu\text{A}$
$I_{IH}$	HIGH level input current		–	300	450	$\mu\text{A}$

## Video analog input interface

## TDA8708A

SYMBOL	PARAMETER	CONDITIONS	MIN.	TYP.	MAX.	UNIT
<b>ADCIN INPUT (PIN 20; SEE TABLE 5)</b>						
$V_{20}$	input voltage	digital output = 00	-	$V_{CCA} - 2.42$	-	V
$V_{20}$	input voltage	digital output = 255	-	$V_{CCA} - 1.41$	-	V
$V_{20(p-p)}$	input voltage amplitude (peak-to-peak value)		-	1.0	-	V
$I_{20}$	input current		-	1.0	10	$\mu$ A
$ Z_i $	input impedance	$f_i = 6$ MHz	-	50	-	M $\Omega$
$C_i$	input capacitance	$f_i = 6$ MHz	-	1	-	pF
<b>Analog-to-digital converter outputs</b>						
DIGITAL OUTPUTS D0 TO D7						
$V_{OL}$	LOW level output voltage	$I_{OL} = 2$ mA	0	-	0.6	V
$V_{OH}$	HIGH level output voltage	$I_{OL} = -0.4$ mA	2.4	-	$V_{CCD}$	V
$I_{OZ}$	output current in 3-state mode	$0.4 V < V_O < V_{CCD}$	-20	-	+20	$\mu$ A
<b>Switching characteristics</b>						
$f_{clk(max)}$	maximum clock input frequency	see Fig.6; note 6	30	32	-	MHz
<b>Analog signal processing (<math>f_{clk} = 32</math> MHz; see Fig.8)</b>						
$G_{diff}$	differential gain	$V_{20} = 1.0$ V (p-p); see Fig.3; note 7	-	2	-	%
$\varphi_{diff}$	differential phase	see Fig.3; note 7	-	2	-	deg
$f_1$	fundamental harmonics (full-scale)	$f_i = 4.43$ MHz; note 7	-	-	0	dB
$f_{all}$	harmonics (full-scale); all components	$f_i = 4.43$ MHz; note 7	-	-55	-	dB
SVRR2	supply voltage ripple rejection	note 8	-	1	5	%/V
<b>Transfer function (see Fig.8)</b>						
ILE	DC integral linearity error		-	-	$\pm 1$	LSB
DLE	DC differential linearity error		-	-	$\pm 0.5$	LSB
ILE	AC integral linearity error	note 9	-	-	$\pm 2$	LSB
<b>Timing (<math>f_{clk} = 32</math> MHz; see Figs 6, 7 and 8)</b>						
DIGITAL OUTPUTS ( $C_L = 15$ pF; $I_{OL} = 2$ mA; $R_L = 2$ k $\Omega$ )						
$t_{ds}$	sampling delay time		-	2	-	ns
$t_h$	output hold time		6	8	-	ns
$t_d$	output delay time		-	16	20	ns
$t_{dEZ}$	3-state delay time; output enable		-	19	25	ns
$t_{dDZ}$	3-state delay time; output disable		-	14	20	ns

## Video analog input interface

## TDA8708A

**Notes**

1. 0 dB is obtained at the AGC amplifier when applying  $V_{i(p-p)} = 1.33$  V.
2. The output current at pin 19 should not exceed 1 mA. The load impedance  $R_L$  should be referenced to  $V_{CCA}$  and defined as:
  - a) AC impedance  $\geq 1$  k $\Omega$  and the DC impedance  $> 2.7$  k $\Omega$ .
  - b) The load impedance should be coupled directly to the output of the amplifier so that the DC voltage supplied by the clamp is not disturbed.
3. Control mode 2 is selected.
4. Signal-to-noise ratio measured with 5 MHz bandwidth:

$$\frac{S}{N} = 20 \log \frac{V_{ANOUTC(p-p)}}{V_{ANOUTY(RMS\ noise)}} \text{ at } B = 5 \text{ MHz.}$$

5. The voltage ratio is expressed as:

$$SVRR1 = 20 \log \frac{\Delta V_{CCA}}{V_{CCA}} \times \frac{G}{\Delta G} \text{ for } V_i = 1 \text{ V (p-p), gain at 100 kHz} = 1 \text{ and 1 V supply variation.}$$

6. It is recommended that the rise and fall times of the clock are  $\geq 2$  ns. In addition, a 'good layout' for the digital and analog grounds is recommended.
7. These measurements are realized on analog signals after a digital-to-analog conversion (TDA8702 is used).
8. The supply voltage rejection is the relative variation of the analog signal (full-scale signal at input) for 1 V of supply variation:

$$SVRR2 = \frac{\Delta(V_{I(00)} - V_{I(FF)}) + (V_{I(00)} - V_{I(FF)})}{\Delta V_{CCA}}$$

9. Full-scale sine wave ( $f_i = 4.4$  MHz;  $f_{clk} = 27$  MHz).

## Video analog input interface

## TDA8708A

**Table 1** Video input selection (CVBS).

I1	I0	SELECTED INPUT
0	0	VIN0
0	1	VIN1
1	0	VIN2
1	1	VIN2

**Table 2** AGC output current.

GATE A	GATE B	DIGITAL OUTPUT	I <sub>AGC</sub>	MODE <sup>(2)</sup>
1	1	output < 255	-2.5 μA	1
		output > 255	I <sub>AGCM</sub>	1
0	X <sup>(1)</sup>	output < 248	0 μA	2
		output > 248	I <sub>AGCM</sub>	2
1	0	output < 0	+2.5 μA	2
		0 < output < 248	-2.5 μA	2
		output > 248	I <sub>AGCM</sub>	2

**Note**

1. X = don't care.
2. Mode 2 can only be initialized with successive pulses on GATE A and GATE B (see Fig.5).

**Table 3** CLAMP output current.

GATE A	GATE B	DIGITAL OUTPUT	I <sub>CLAMP</sub>	MODE
1	1	output < 0	I <sub>CLAMPM</sub>	1
		output > 0	-2.5 μA	1
X <sup>(1)</sup>	0	X <sup>(1)</sup>	0 μA	2
0	1	output < 64	+50 μA	2
		64 < output	-50 μA	2

**Note**

1. X = don't care.

**Table 4** OF input coding.

OF	D0 TO D7
0	active, two's complement
1	high impedance
open circuit <sup>(1)</sup>	active, binary

**Note**

1. Use C ≥ 10 pF to DGND.

**Table 5** Output coding and input voltage (typical values).

STEP	V <sub>ADCIN</sub>	BINARY OUTPUTS								TWO'S COMPLEMENT							
		D7	D6	D5	D4	D3	D2	D1	D0	D7	D6	D5	D4	D3	D2	D1	D0
Underflow	-	0	0	0	0	0	0	0	0	1	0	0	0	0	0	0	0
0	V <sub>CCA</sub> - 2.41 V	0	0	0	0	0	0	0	0	1	0	0	0	0	0	0	0
1	-	0	0	0	0	0	0	0	1	1	0	0	0	0	0	0	1
.	-	.	.	.	.	.	.	.	.	.	.	.	.	.	.	.	.
.	-	.	.	.	.	.	.	.	.	.	.	.	.	.	.	.	.
254	-	1	1	1	1	1	1	1	0	0	1	1	1	1	1	1	0
255	V <sub>CCA</sub> - 1.41 V	1	1	1	1	1	1	1	1	0	1	1	1	1	1	1	1
Overflow	-	1	1	1	1	1	1	1	1	0	1	1	1	1	1	1	1

Video analog input interface

TDA8708A

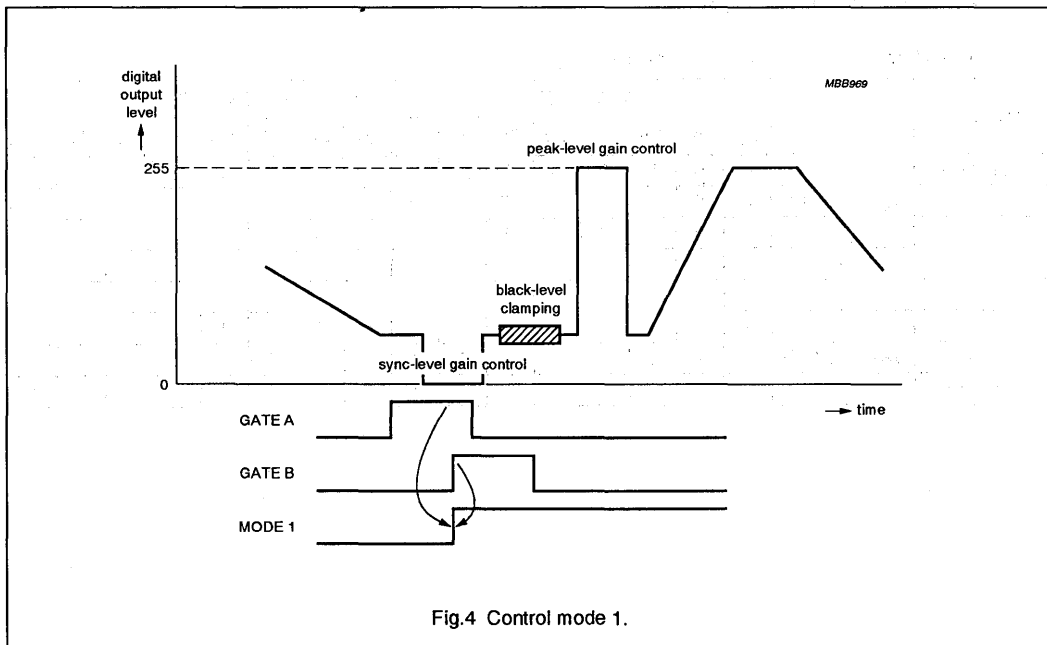
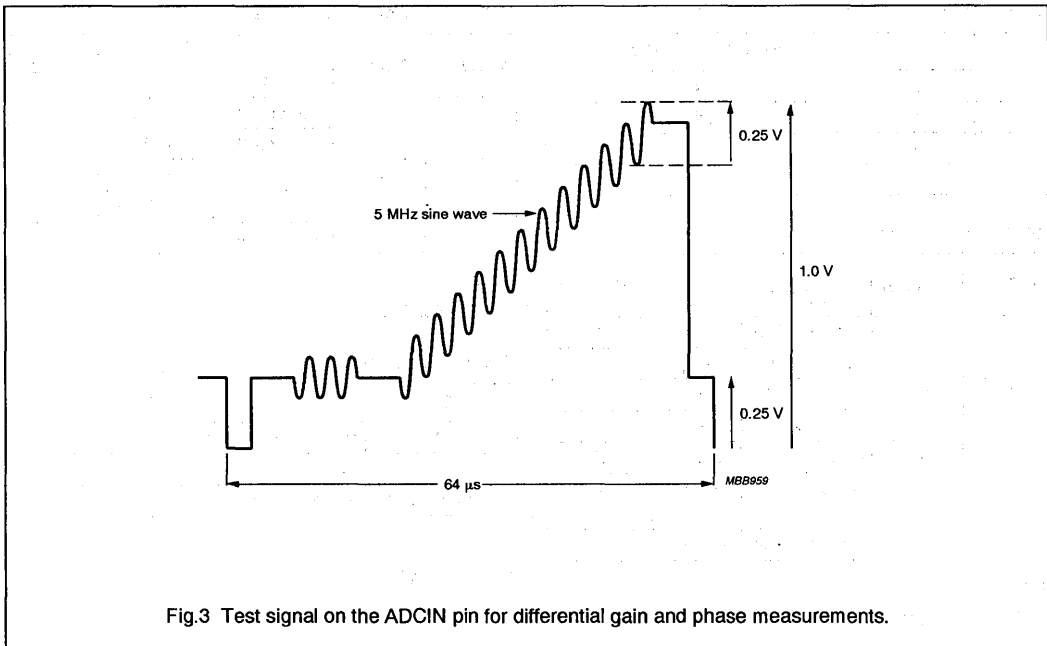

Video analog input interface

TDA8708A

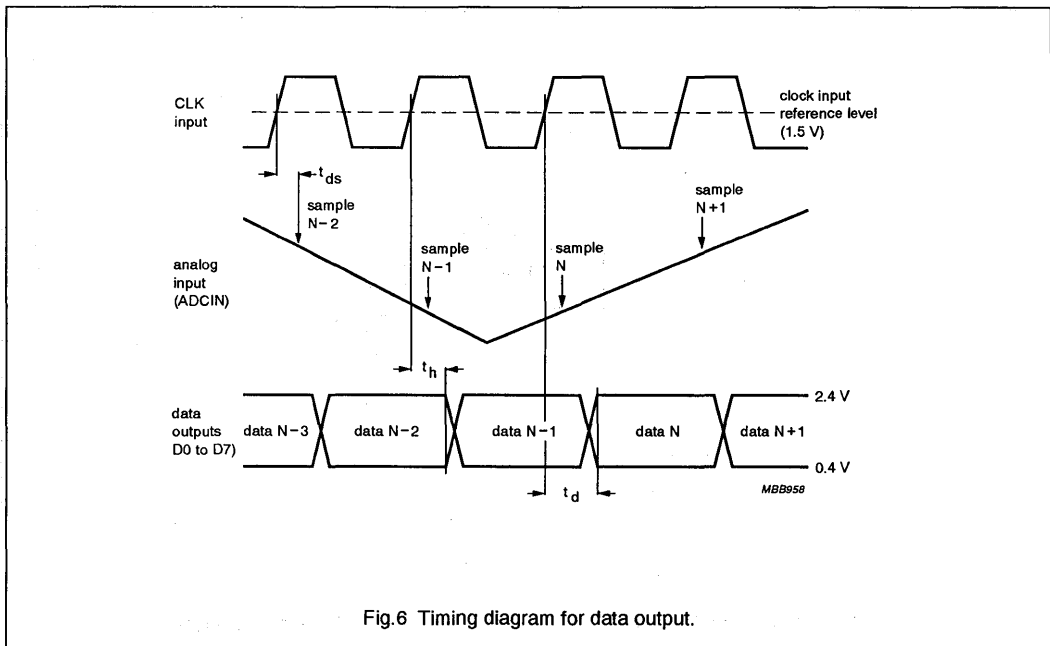
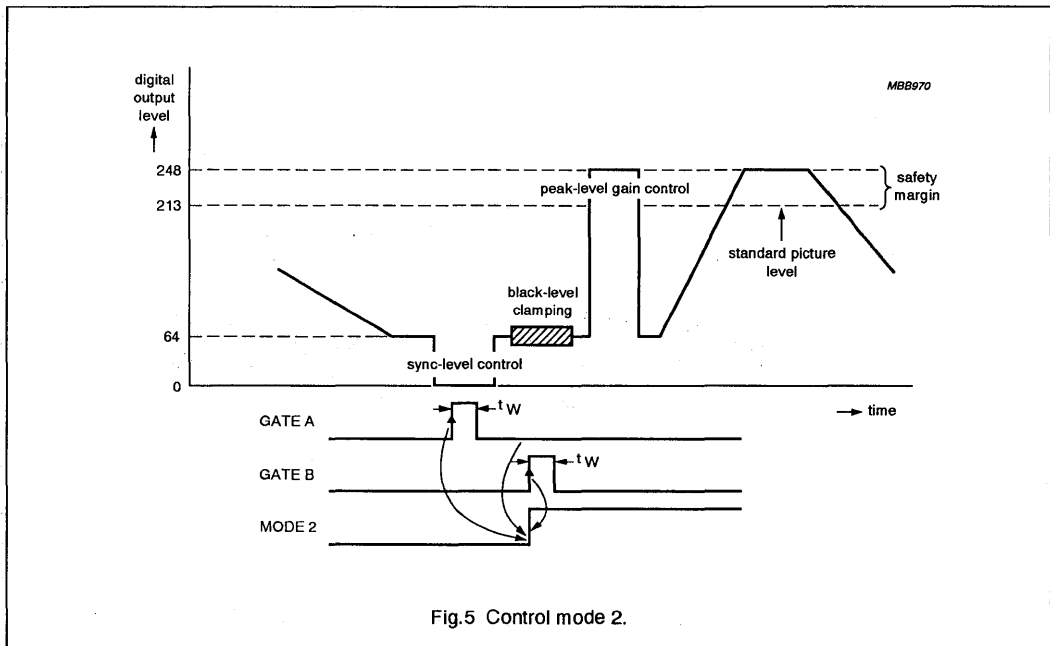

Video analog input interface

TDA8708A

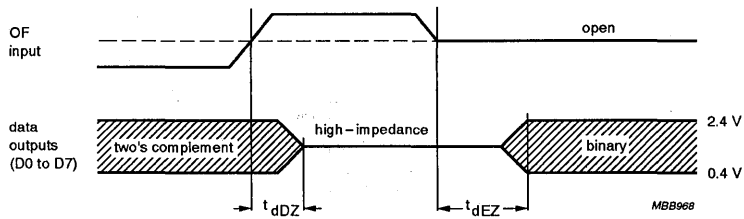

Fig.7 Output format timing diagram.

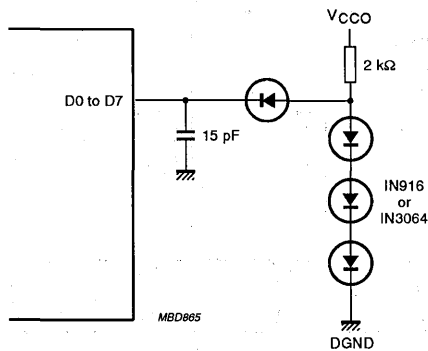

Fig.8 Load circuit for timing measurement; data outputs (OF = LOW or open-circuit).



Video analog input interface

TDA8708A

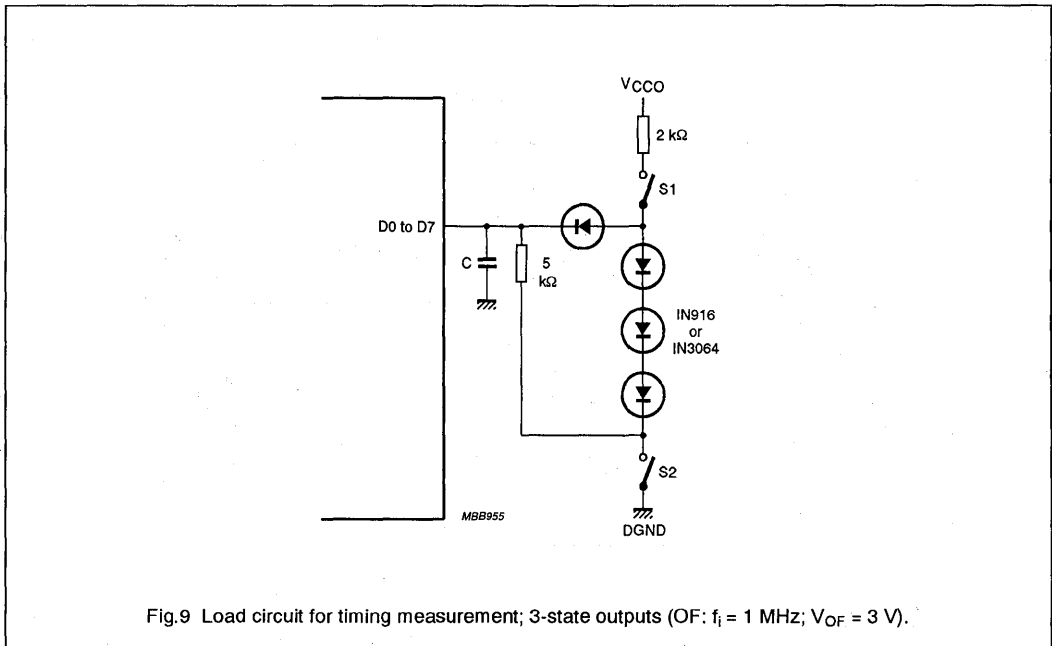
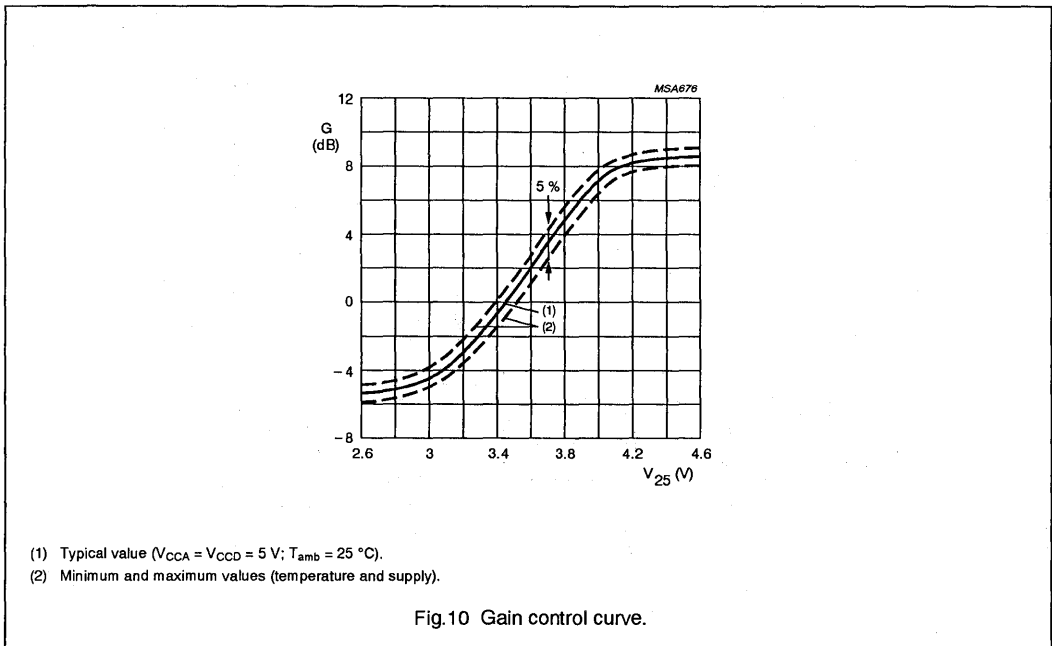

Fig.9 Load circuit for timing measurement; 3-state outputs (OF:  $f_i = 1 \text{ MHz}$ ;  $V_{OF} = 3 \text{ V}$ ).



- (1) Typical value ( $V_{CCA} = V_{CCD} = 5 \text{ V}$ ;  $T_{amb} = 25 \text{ }^\circ\text{C}$ ).
- (2) Minimum and maximum values (temperature and supply).

Fig.10 Gain control curve.

Video analog input interface

TDA8708A

INTERNAL PIN CIRCUITRY

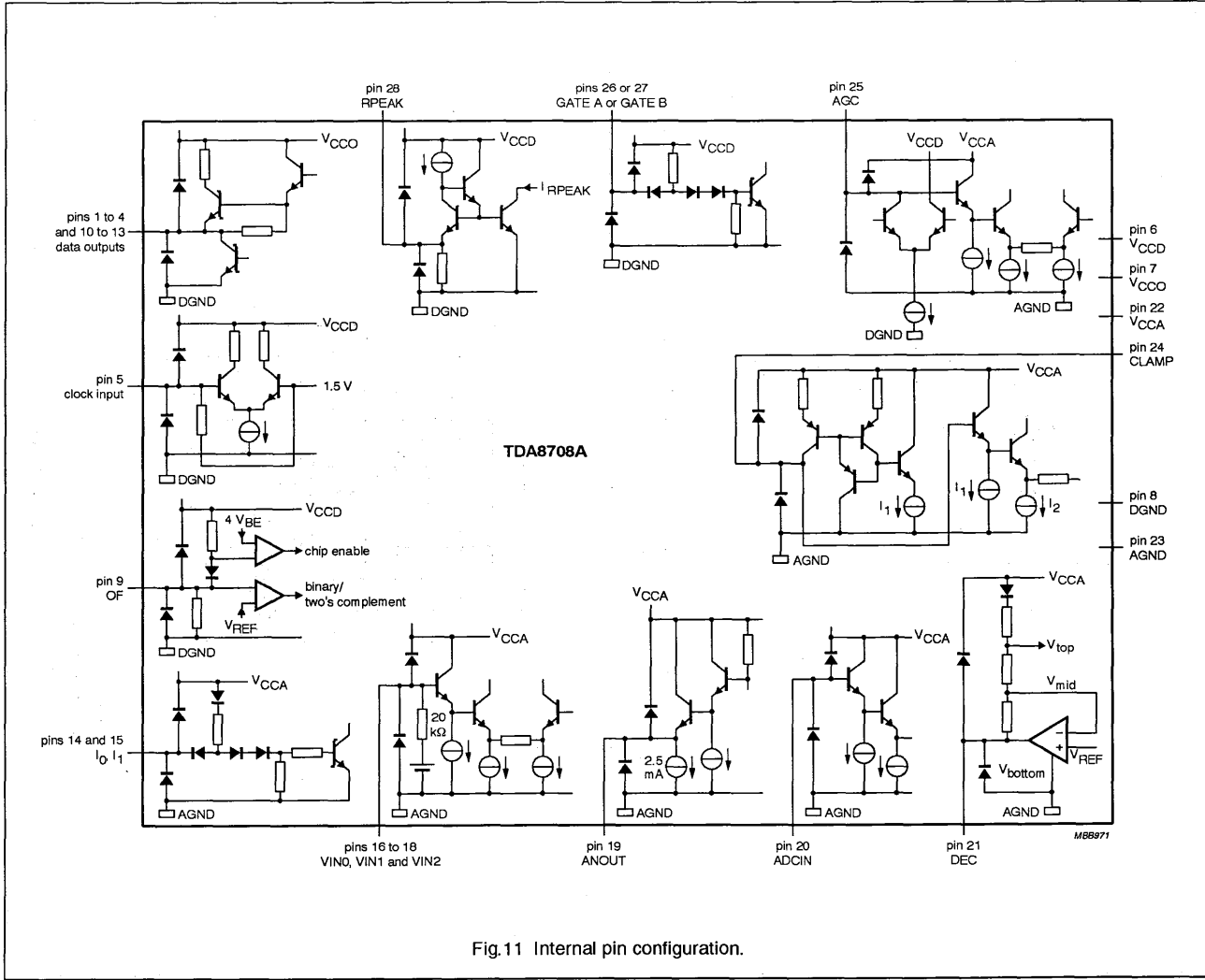

Fig.11 Internal pin configuration.

Video analog input interface

TDA8708A

APPLICATION INFORMATION

Additional information can be found in the laboratory report "FBL/AN9308".

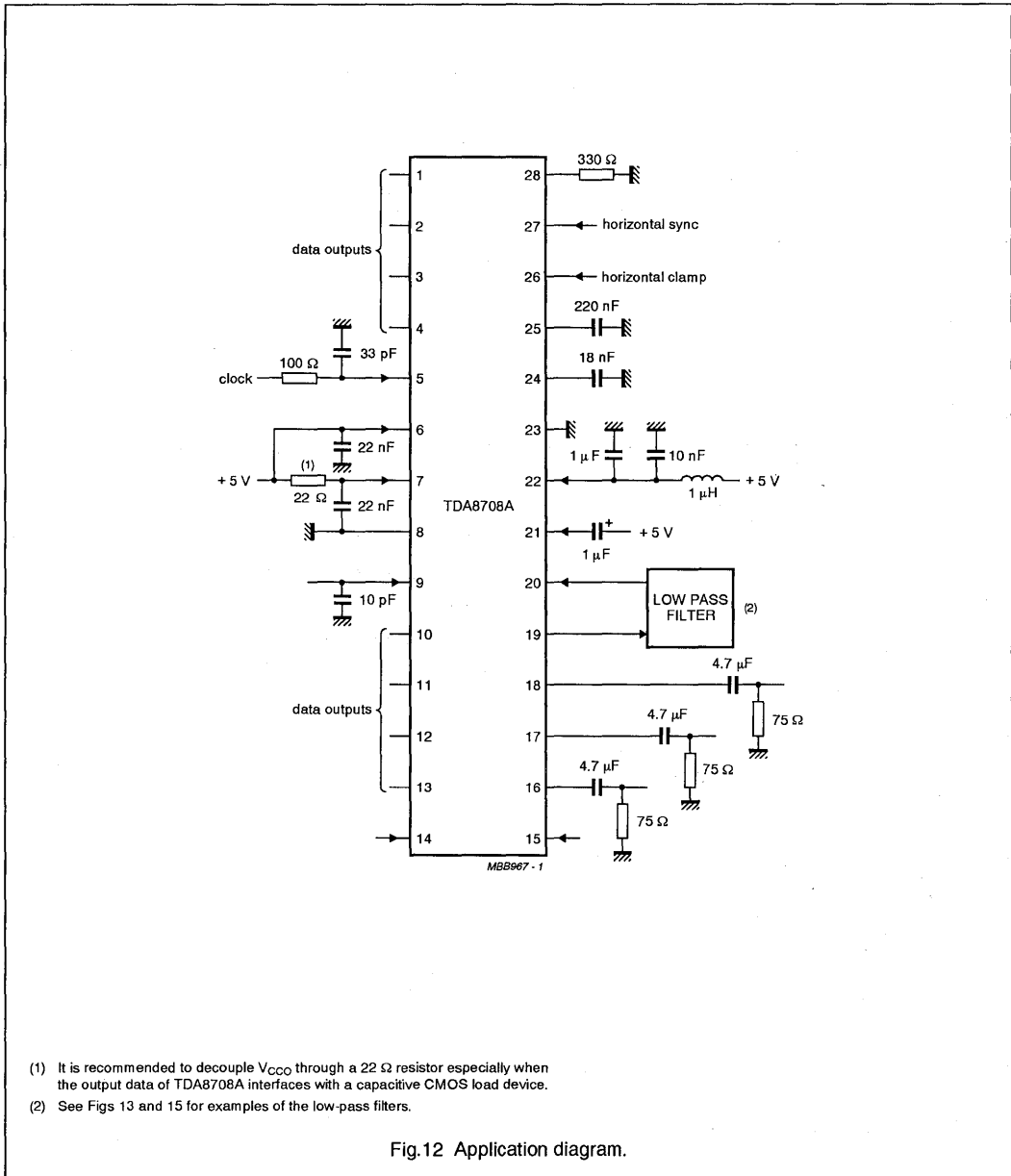

- (1) It is recommended to decouple V<sub>CCO</sub> through a 22 Ω resistor especially when the output data of TDA8708A interfaces with a capacitive CMOS load device.
- (2) See Figs 13 and 15 for examples of the low-pass filters.

Fig.12 Application diagram.

Video analog input interface

TDA8708A

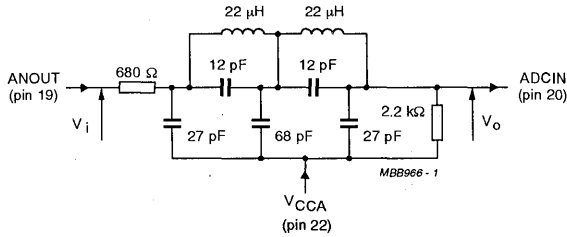

This filter can be adapted to various applications with respect to performance requirements. An input and output impedance of at least 680 Ω and 2.2 kΩ must in any event be applied.

Fig.13 Example of a low-pass filter for CVBS and Y signals.

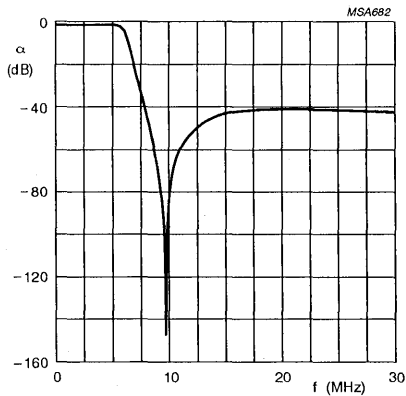

Fig.14 Frequency response for filter shown in Fig.13.

Characteristics of Fig. 13

- Order 5; adapted CHEBYSHEV
- Ripple  $\rho \leq 0.4$  dB
- $f = 6.5$  MHz at  $-3$  dB
- $f_{\text{notch}} = 9.75$  MHz.

Video analog input interface

TDA8708A

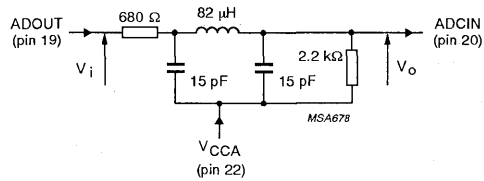

This filter can be adapted to various applications with respect to performance requirements. An input and output impedance of at least 680 Ω and 2.2 kΩ must in any event be applied.

Fig.15 Example of an economical low-pass filter for CVBS and Y signals.

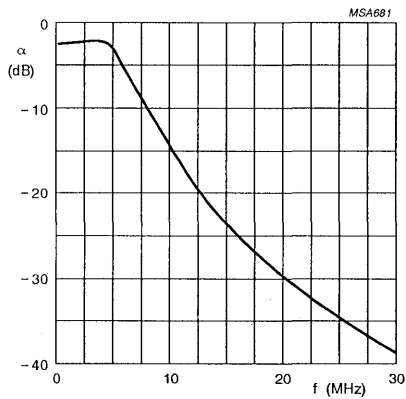

Fig.16 Frequency response for filter shown in Fig.15.

Characteristics of Fig. 15

- Order 5; adapted CHEBYSHEV
- Ripple  $\rho \leq 0.4$  dB
- $f = 6.5$  MHz at  $-3$  dB.

## Video analog input interface

## TDA8708B

## FEATURES

- 8-bit resolution
- Sampling rate up to 32 MHz
- Binary or two's complement 3-state TTL outputs
- TTL-compatible digital inputs and outputs
- Internal reference voltage regulator
- Power dissipation of 365 mW (typical)
- Input selector circuit (one out of three video inputs)
- Clamp and Automatic Gain Control (AGC) functions for CVBS and Y signals
- No sample-and-hold circuit required
- The TDA8708B has no white peak control in mode 2 whereas the TDA8708A has control in modes 1 and 2.
- In-range output (not TTL levels).

## APPLICATIONS

- Video signal decoding
- Scrambled TV (encoding and decoding)
- Digital picture processing
- Frame grabbing.

## GENERAL DESCRIPTION

The TDA8708B is an analog input interface for video signal processing. It includes a video amplifier with clamp and gain control, an 8-bit analog-to-digital converter (ADC) with a sampling rate of 32 MHz and an input selector.

## QUICK REFERENCE DATA

SYMBOL	PARAMETER	MIN.	TYP.	MAX.	UNIT
V <sub>CCA</sub>	analog supply voltage	4.5	5.0	5.5	V
V <sub>CCD</sub>	digital supply voltage	4.5	5.0	5.5	V
V <sub>CCO</sub>	TTL output supply voltage	4.2	5.0	5.5	V
I <sub>CCA</sub>	analog supply current	–	37	45	mA
I <sub>CCD</sub>	digital supply current	–	24	30	mA
I <sub>CCO</sub>	TTL output supply current	–	12	16	mA
ILE	DC integral linearity error	–	–	±1	LSB
DLE	DC differential linearity error	–	–	±0.5	LSB
f <sub>clk(max)</sub>	maximum clock frequency	30	32	–	MHz
B	maximum –3 dB bandwidth (AGC amplifier)	12	18	–	MHz
P <sub>tot</sub>	total power dissipation	–	365	500	mW

## ORDERING INFORMATION

TYPE NUMBER	PACKAGE			
	PINS	PIN POSITION	MATERIAL	CODE
TDA8708B	28	DIP	plastic	SOT117-1
TDA8708BT	28	SO28L	plastic	SOT136-1

Video analog input interface

TDA8708B

BLOCK DIAGRAM

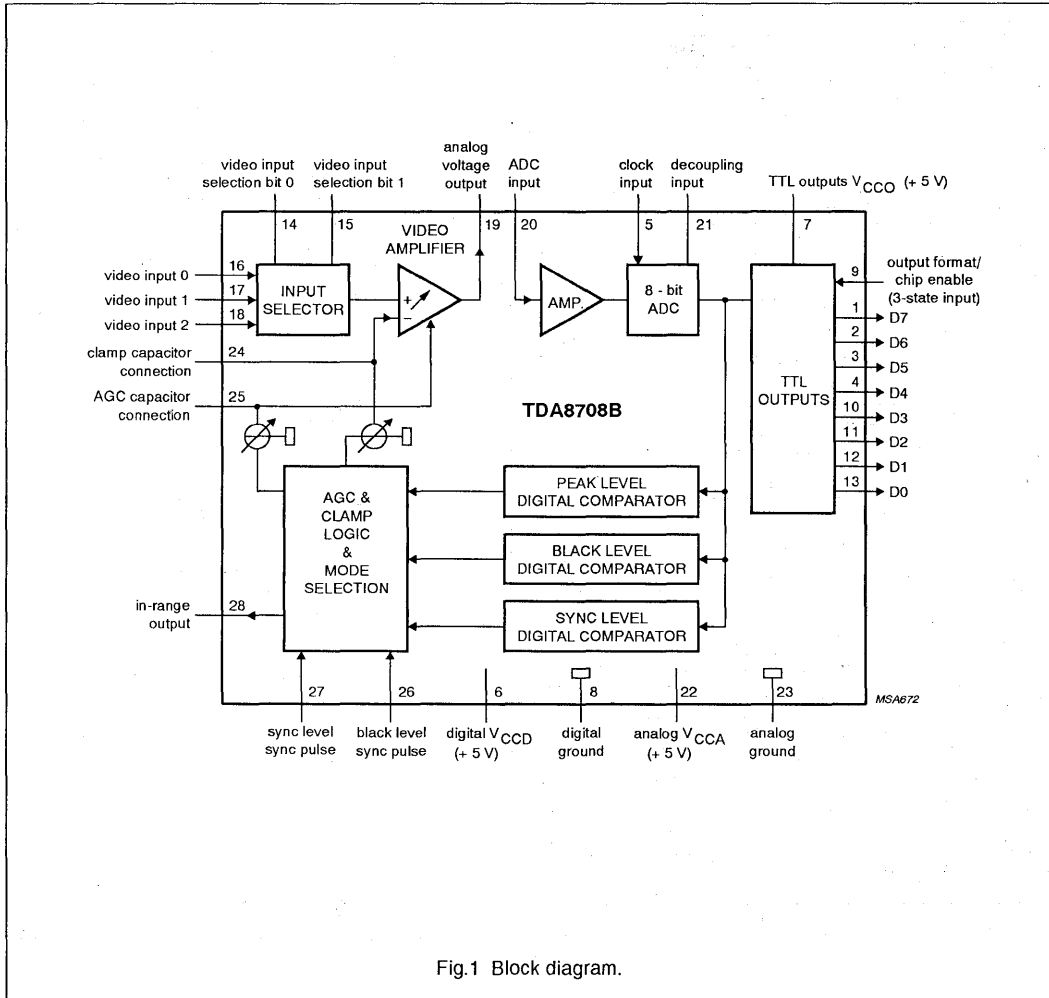

Fig.1 Block diagram.

Video analog input interface

TDA8708B

PINNING

SYMBOL	PIN	DESCRIPTION
D7	1	data output; bit 7 (MSB)
D6	2	data output; bit 6
D5	3	data output; bit 5
D4	4	data output; bit 4
CLK	5	clock input
V <sub>CCD</sub>	6	digital supply voltage (+5 V)
V <sub>CCO</sub>	7	TTL outputs supply voltage (+5 V)
DGND	8	digital ground
OF	9	output format/chip enable (3-state input)
D3	10	data output; bit 3
D2	11	data output; bit 2
D1	12	data output; bit 1
D0	13	data output; bit 0 (LSB)
I0	14	video input selection bit 0
I1	15	video input selection bit 1
VIN0	16	video input 0
VIN1	17	video input 1
VIN2	18	video input 2
ANOUT	19	analog voltage output
ADCIN	20	analog-to-digital converter input
DEC	21	decoupling input
V <sub>CCA</sub>	22	analog supply voltage (+5 V)
AGND	23	analog ground
CLAMP	24	clamp capacitor connection
AGC	25	AGC capacitor connection
GATE B	26	black level synchronization pulse
GATE A	27	sync level synchronization pulse
IR	28	in-range output

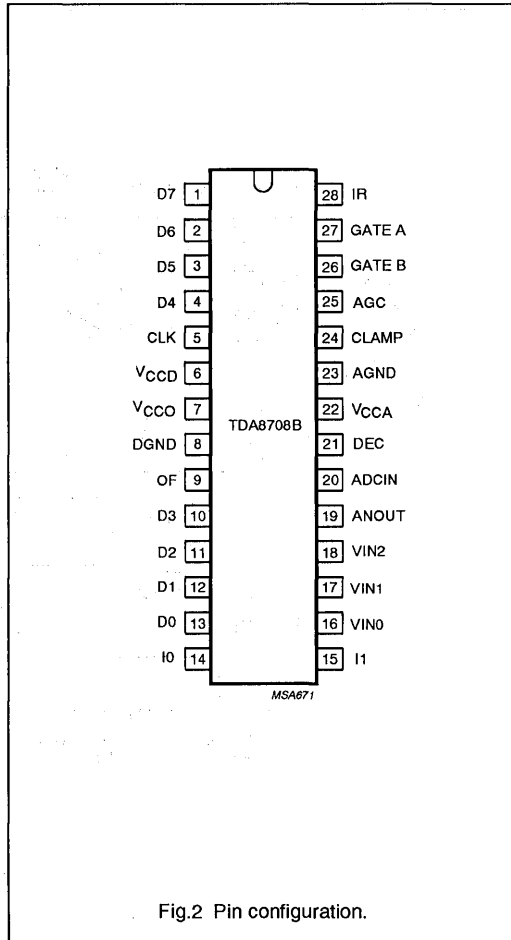

Fig.2 Pin configuration.



## Video analog input interface

## TDA8708B

**FUNCTIONAL DESCRIPTION**

The TDA8708B provides a simple interface for decoding video signals.

The TDA8708B operates in configuration mode 1 (see Fig. 4) when the video signals are weak (i.e. when the gain of the AGC amplifier has not yet reached its optimum value). This enables a fast recovery of the synchronization pulses in the decoder circuit. When the pulses at the GATE A and GATE B inputs become distinct (GATE A and GATE B pulses are synchronization pulses occurring during the sync period and rear porch respectively) the TDA8708B automatically switches to configuration mode 2 (see Fig.5).

When the TDA8708B is in configuration mode 1, the gain of the AGC amplifier will be roughly adjusted (sync level to a digital output level of 0 and the peak level to a digital output level of 255).

In configuration mode 2 the digital output of the ADC is compared to internal digital reference levels. The voltage

across the capacitor connected to the AGC pin controls the gain of the video amplifier. This is the gain control loop.

The sync level comparator is active during a positive-going pulse at the GATE A input. This means that the sync pulse of the composite video signal is used as an amplitude reference. The bottom of the sync pulse is adjusted to obtain a digital output of logic 0 at the converter output. As the black level is at digital level 64, the sync pulse will have a digital amplitude of 64 LSBs.

The use of nominal signals will prevent the output from exceeding a digital code of 213.

The clamp level control is accomplished by using the same techniques as used for the gain control. The black-level digital comparator is active during a positive-going pulse at the GATE B input. The clamp capacitor will be charged or discharged to adjust the digital output to code 64.

**LIMITING VALUES**

In accordance with the Absolute Maximum Rating System (IEC 134).

SYMBOL	PARAMETER	MIN.	MAX.	UNIT
$V_{CCA}$	analog supply voltage	-0.3	+7.0	V
$V_{CCD}$	digital supply voltage	-0.3	+7.0	V
$V_{CCO}$	TTL output supply voltage	-0.3	+7.0	V
$\Delta V_{CC}$	supply voltage difference between $V_{CCA}$ and $V_{CCD}$	-1.0	+1.0	V
	supply voltage difference between $V_{CCO}$ and $V_{CCD}$	-1.0	+1.0	V
	supply voltage difference between $V_{CCA}$ and $V_{CCO}$	-1.0	+1.0	V
$V_I$	input voltage	-0.3	$V_{CCA}$	V
$I_O$	output current	0	+10	mA
$T_{stg}$	storage temperature	-55	+150	°C
$T_{amb}$	operating ambient temperature	0	+70	°C
$T_j$	junction temperature	0	+125	°C

**THERMAL CHARACTERISTICS**

SYMBOL	PARAMETER	VALUE	UNIT
$R_{th\ j-a}$	thermal resistance from junction to ambient in free air		
	SOT117-1	55	K/W
	SOT136-1	70	K/W

## Video analog input interface

## TDA8708B

**CHARACTERISTICS**

$V_{CCA} = V_{22}$  to  $V_{23} = 4.5$  to  $5.5$  V;  $V_{CCD} = V_6$  to  $V_8 = 4.5$  to  $5.5$  V;  $V_{CCO} = V_7$  to  $V_8 = 4.2$  to  $5.5$  V; AGND and DGND shorted together;  $V_{CCA}$  to  $V_{CCD} = -0.5$  to  $+0.5$  V;  $V_{CCO}$  to  $V_{CCD} = -0.5$  to  $+0.5$  V;  $V_{CCA}$  to  $V_{CCO} = -0.5$  to  $+0.5$  V;  $T_{amb} = 0$  to  $+70$  °C; typical readings taken at  $V_{CCA} = V_{CCD} = V_{CCO} = 5$  V and  $T_{amb} = 25$  °C; unless otherwise specified.

SYMBOL	PARAMETER	CONDITIONS	MIN.	TYP.	MAX.	UNIT
<b>Supplies</b>						
$V_{CCA}$	analog supply voltage		4.5	5.0	5.5	V
$V_{CCD}$	digital supply voltage		4.5	5.0	5.5	V
$V_{CCO}$	TTL output supply voltage		4.2	5.0	5.5	V
$I_{CCA}$	analog supply current		–	37	45	mA
$I_{CCD}$	digital supply current		–	24	30	mA
$I_{CCO}$	TTL output supply current	TTL load (see Fig.8)	–	12	16	mA
<b>Video amplifier inputs</b>						
VIN0 TO VIN2 INPUTS						
$V_{I(p-p)}$	input voltage (peak-to-peak value)	AGC load with external capacitor; note 1	0.6	–	1.5	V
$ Z_I $	input impedance	$f_i = 6$ MHz	10	20	–	k $\Omega$
$C_I$	input capacitance	$f_i = 6$ MHz	–	1	–	pF
I0 AND I1 TTL INPUTS (SEE TABLE 1)						
$V_{IL}$	LOW level input voltage		0	–	0.8	V
$V_{IH}$	HIGH level input voltage		2.0	–	$V_{CCD}$	V
$I_{IL}$	LOW level input current	$V_I = 0.4$ V	–400	–	–	$\mu$ A
$I_{IH}$	HIGH level input current	$V_I = 2.7$ V	–	–	20	$\mu$ A
GATE A AND GATE B TTL INPUTS (SEE FIGS 4 AND 5)						
$V_{IL}$	LOW level input voltage		0	–	0.8	V
$V_{IH}$	HIGH level input voltage		2.0	–	$V_{CCD}$	V
$I_{IL}$	LOW level input current	$V_I = 0.4$ V	–400	–	–	$\mu$ A
$I_{IH}$	HIGH level input current	$V_I = 2.7$ V	–	–	20	$\mu$ A
$t_w$	pulse width	see Fig.5	2	–	–	$\mu$ s
AGC INPUT (PIN 25)						
$V_{25(min)}$	AGC voltage for minimum gain		–	2.8	–	V
$V_{25(max)}$	AGC voltage for maximum gain		–	4.0	–	V
	AGC output current		see Table 2			
CLAMP INPUT (PIN 24)						
$V_{24}$	clamp voltage for code 128 output		–	3.5	–	V
$I_{24}$	clamp output current		see Table 3			

## Video analog input interface

## TDA8708B

SYMBOL	PARAMETER	CONDITIONS	MIN.	TYP.	MAX.	UNIT
<b>Video amplifier outputs</b>						
ANOUT OUTPUT (PIN 19)						
$V_{19(p-p)}$	AC output voltage (peak-to-peak value)	$V_{VIN} = 1.33 \text{ V (p-p)}$ ; $V_{25} = 3.6 \text{ V}$	–	1.33	–	V
$I_{19}$	internal current source	$R_L = \infty$	2.0	2.5	–	mA
$I_{O(p-p)}$	output current driven by the load	$V_{ANOUT} = 1.33 \text{ V (p-p)}$ ; note 2	–	–	1.0	mA
$V_{19}$	DC output voltage for black level	note 3	–	$V_{CCA} - 2.24$	–	V
$Z_{19}$	output impedance		–	20	–	$\Omega$
<b>Video amplifier dynamic characteristics</b>						
$\alpha_{ct}$	crosstalk between VIN inputs	$V_{CCA} = 4.75 \text{ to } 5.25 \text{ V}$	–	–50	–45	dB
$G_{diff}$	differential gain	$V_{VIN} = 1.33 \text{ V (p-p)}$ ; $V_{25} = 3.6 \text{ V}$	–	2	–	%
$\varphi_{diff}$	differential phase	$V_{VIN} = 1.33 \text{ V (p-p)}$ ; $V_{25} = 3.6 \text{ V}$	–	0.8	–	deg
B	–3 dB bandwidth		12	–	–	MHz
S/N	signal-to-noise ratio	note 4	60	–	–	dB
SVRR1	supply voltage ripple rejection	note 5	–	45	–	dB
$\Delta G$	gain range	see Fig.10	–4.5	–	+6.0	dB
$G_{stab}$	gain stability as a function of supply voltage and temperature	see Fig.10	–	–	5	%
<b>Analog-to-digital converter inputs</b>						
CLK INPUT (PIN 5)						
$V_{IL}$	LOW level input voltage		0	–	0.8	V
$V_{IH}$	HIGH level input voltage		2.0	–	$V_{CCD}$	V
$I_{IL}$	LOW level input current	$V_{clk} = 0.4 \text{ V}$	–400	–	–	$\mu\text{A}$
$I_{IH}$	HIGH level input current	$V_{clk} = 2.7 \text{ V}$	–	–	100	$\mu\text{A}$
$ Z_i $	input impedance	$f_{clk} = 10 \text{ MHz}$	–	4	–	k $\Omega$
$C_i$	input capacitance	$f_{clk} = 10 \text{ MHz}$	–	4.5	–	pF
OF INPUT (3-STATE; SEE TABLE 4)						
$V_{IL}$	LOW level input voltage		0	–	0.2	V
$V_{IH}$	HIGH level input voltage		2.6	–	$V_{CCD}$	V
$V_s$	input voltage in high impedance state		–	1.15	–	V
$I_{IL}$	LOW level input current		–370	–300	–	$\mu\text{A}$
$I_{IH}$	HIGH level input current		–	300	450	$\mu\text{A}$

## Video analog input interface

## TDA8708B

SYMBOL	PARAMETER	CONDITIONS	MIN.	TYP.	MAX.	UNIT
<b>ADCIN INPUT (PIN 20; SEE TABLE 5)</b>						
V <sub>20</sub>	input voltage	digital output = 00	–	V <sub>CCA</sub> – 2.42	–	V
V <sub>20</sub>	input voltage	digital output = 255	–	V <sub>CCA</sub> – 1.41	–	V
V <sub>20(p-p)</sub>	input voltage amplitude (peak-to-peak value)		–	1.0	–	V
I <sub>20</sub>	input current		–	1.0	10	μA
Z <sub>i</sub>	input impedance	f <sub>i</sub> = 6 MHz	–	50	–	MΩ
C <sub>i</sub>	input capacitance	f <sub>i</sub> = 6 MHz	–	1	–	pF
<b>Analog-to-digital converter outputs</b>						
<b>IR OUTPUT (PIN 28)</b>						
V <sub>OL</sub>	LOW level output voltage		–	–	1.7	V
V <sub>OH</sub>	HIGH level output voltage		1.9	–	–	V
I <sub>O</sub>	output current		–500	–	–	μA
<b>DIGITAL OUTPUTS D0 TO D7</b>						
V <sub>OL</sub>	LOW level output voltage	I <sub>OL</sub> = 2 mA	0	–	0.6	V
V <sub>OH</sub>	HIGH level output voltage	I <sub>OL</sub> = –0.4 mA	2.4	–	V <sub>CCD</sub>	V
I <sub>OZ</sub>	output current in 3-state mode	0.4 V < V <sub>O</sub> < V <sub>CCD</sub>	–20	–	+20	μA
<b>Switching characteristics</b>						
f <sub>clk(max)</sub>	maximum clock input frequency	see Fig.6; note 6	30	32	–	MHz
<b>Analog signal processing (f<sub>clk</sub> = 32 MHz; see Fig.8)</b>						
G <sub>diff</sub>	differential gain	V <sub>20</sub> = 1.0 V (p-p); see Fig.3; note 7	–	2	–	%
φ <sub>diff</sub>	differential phase	see Fig.3; note 7	–	2	–	deg
f <sub>1</sub>	fundamental harmonics (full-scale)	f <sub>i</sub> = 4.43 MHz; note 7	–	–	0	dB
f <sub>all</sub>	harmonics (full-scale); all components	f <sub>i</sub> = 4.43 MHz; note 7	–	–55	–	dB
SVRR2	supply voltage ripple rejection	note 8	–	1	5	%/V
<b>Transfer function (see Fig.8)</b>						
ILE	DC integral linearity error		–	–	±1	LSB
DLE	DC differential linearity error		–	–	±0.5	LSB
ILE	AC integral linearity error	note 9	–	–	±2	LSB
<b>Timing (f<sub>clk</sub> = 32 MHz; see Figs 6, 7 and 8)</b>						
<b>DIGITAL OUTPUTS (C<sub>L</sub> = 15 pF; I<sub>OL</sub> = 2 mA; R<sub>L</sub> = 2 kΩ)</b>						
t <sub>ds</sub>	sampling delay time		–	2	–	ns
t <sub>h</sub>	output hold time		6	8	–	ns
t <sub>d</sub>	output delay time		–	16	20	ns
t <sub>dEZ</sub>	3-state delay time; output enable		–	19	25	ns
t <sub>dZ</sub>	3-state delay time; output disable		–	14	20	ns

## Video analog input interface

## TDA8708B

**Notes to the "Characteristics"**

1. 0 dB is obtained at the AGC amplifier when applying  $V_{i(p-p)} = 1.33$  V.
2. The output current at pin 19 should not exceed 1 mA. The load impedance  $R_L$  should be referenced to  $V_{CCA}$  and defined as:
  - a) AC impedance  $\geq 1$  k $\Omega$  and the DC impedance  $> 2.7$  k $\Omega$ .
  - b) The load impedance should be coupled directly to the output of the amplifier so that the DC voltage supplied by the clamp is not disturbed.
3. Control mode 2 is selected.
4. Signal-to-noise ratio measured with 5 MHz bandwidth:

$$\frac{S}{N} = 20 \log \frac{V_{ANOUTC(p-p)}}{V_{ANOUTY(RMS\ noise)}} \text{ at } B = 5 \text{ MHz.}$$

5. The voltage ratio is expressed as:

$$SVRR1 = 20 \log \frac{\Delta V_{CCA}}{V_{CCA}} \times \frac{G}{\Delta G} \text{ for } V_I = 1 \text{ V (p-p), gain at 100 kHz} = 1 \text{ and 1 V supply variation.}$$

6. It is recommended that the rise and fall times of the clock are  $\geq 2$  ns. In addition, a 'good layout' for the digital and analog grounds is recommended.
7. These measurements are realized on analog signals after a digital-to-analog conversion (TDA8702 is used).
8. The supply voltage rejection is the relative variation of the analog signal (full-scale signal at input) for 1 V of supply variation:

$$SVRR2 = \frac{\Delta(V_{I(00)} - V_{I(FF)}) + (V_{I(00)} - V_{I(FF)})}{\Delta V_{CCA}}$$

9. Full-scale sine wave ( $f_i = 4.4$  MHz;  $f_{clk} = 27$  MHz).

Video analog input interface

TDA8708B

**Table 1** Video input selection (CVBS).

I1	I0	SELECTED INPUT
0	0	VIN0
0	1	VIN1
1	0	VIN2
1	1	VIN2

**Table 2** AGC output current.

GATE A	GATE B	DIGITAL OUTPUT	I <sub>AGC</sub>	MODE <sup>(2)</sup>
1	1	output < 255	-2.5 μA	1
		output > 255	130 μA	1
0	X <sup>(1)</sup>	-	0 μA	2
1	0	output < 0	+2.5 μA	2
		output > 0	-2.5 μA	2

**Notes**

1. X = don't care.
2. Mode 2 can only be initialized with successive pulses on GATE A and GATE B (see Fig.5).

**Table 3** CLAMP output current.

GATE A	GATE B	DIGITAL OUTPUT	I <sub>CLAMP</sub>	MODE
1	1	output < 0	130 μA	1
		output > 0	-2.5 μA	1
X <sup>(1)</sup>	0	X	0 μA	2
0	1	output < 64	+50 μA	2
		64 < output	-50 μA	2

**Note**

1. X = don't care.

**Table 4** OF input coding.

OF	D0 TO D7
0	active, two's complement
1	high impedance
open circuit <sup>(1)</sup>	active, binary

**Note**

1. Use C ≥ 10 pF to DGND.

**Table 5** Output coding and input voltage (typical values).

STEP	V <sub>ADCIN</sub>	BINARY OUTPUTS								TWO'S COMPLEMENT							
		D7	D6	D5	D4	D3	D2	D1	D0	D7	D6	D5	D4	D3	D2	D1	D0
Underflow	-	0	0	0	0	0	0	0	0	1	0	0	0	0	0	0	0
0	V <sub>CCA</sub> - 2.41 V	0	0	0	0	0	0	0	0	1	0	0	0	0	0	0	0
1	-	0	0	0	0	0	0	0	1	1	0	0	0	0	0	0	1
.	-	.	.	.	.	.	.	.	.	.	.	.	.	.	.	.	.
.	-	.	.	.	.	.	.	.	.	.	.	.	.	.	.	.	.
254	-	1	1	1	1	1	1	1	0	0	1	1	1	1	1	1	0
255	V <sub>CCA</sub> - 1.41 V	1	1	1	1	1	1	1	1	0	1	1	1	1	1	1	1
Overflow	-	1	1	1	1	1	1	1	1	0	1	1	1	1	1	1	1

Video analog input interface

TDA8708B

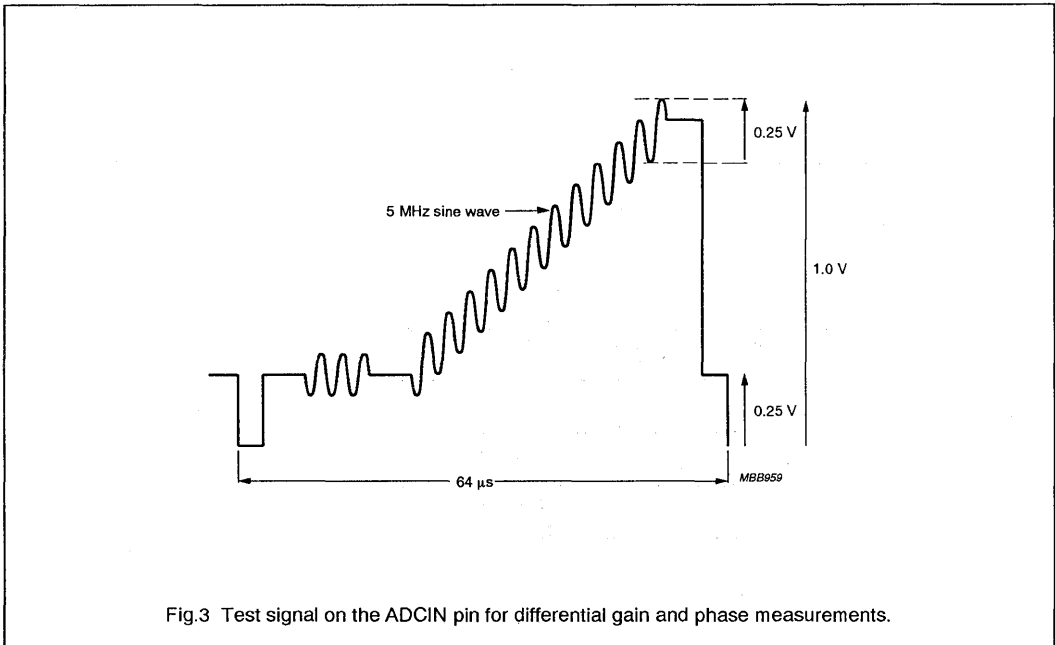

Fig.3 Test signal on the ADCIN pin for differential gain and phase measurements.

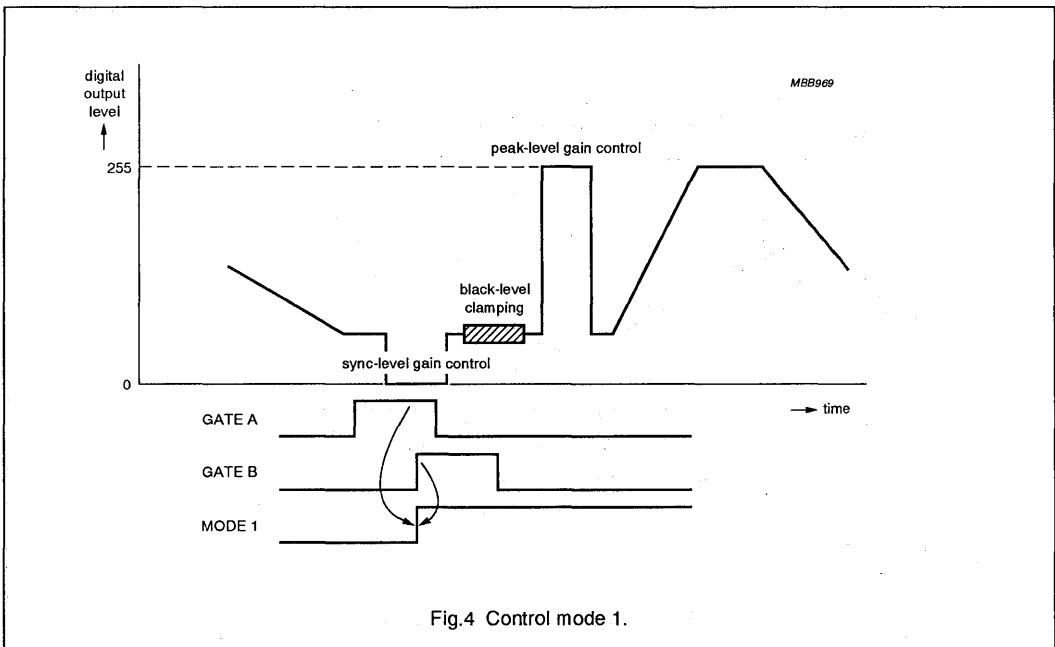

Fig.4 Control mode 1.

Video analog input interface

TDA8708B

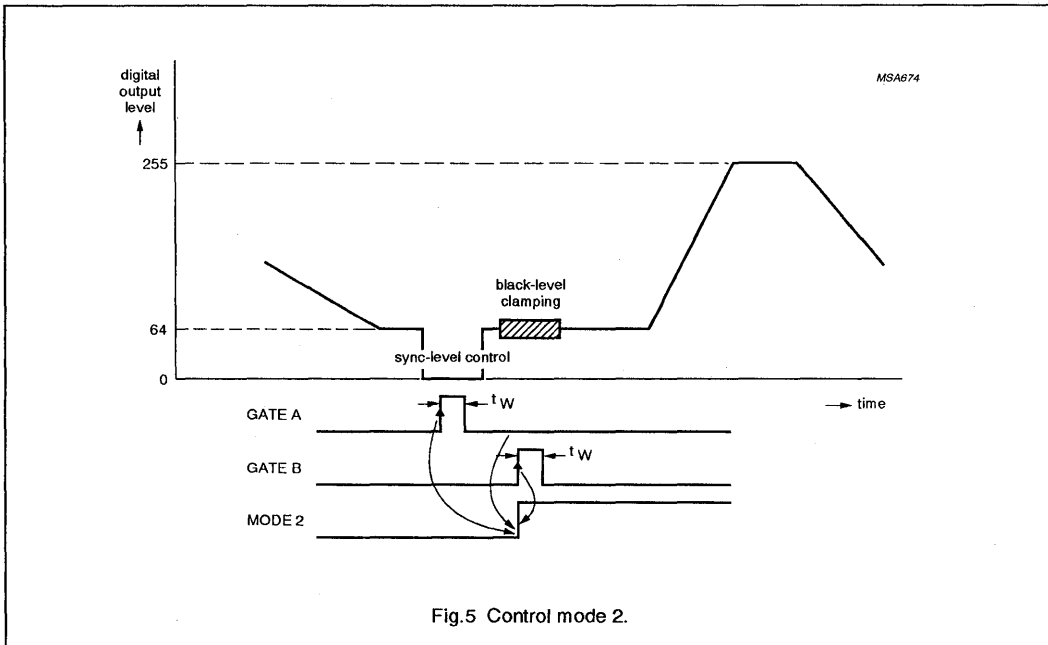

Fig.5 Control mode 2.

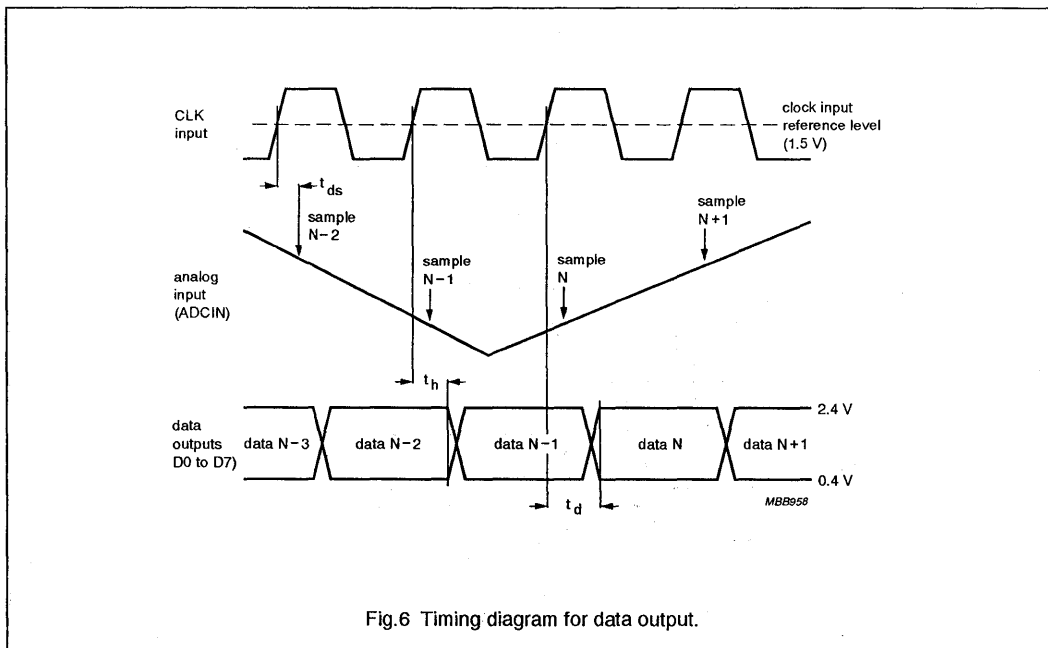

Fig.6 Timing diagram for data output.



Video analog input interface

TDA8708B

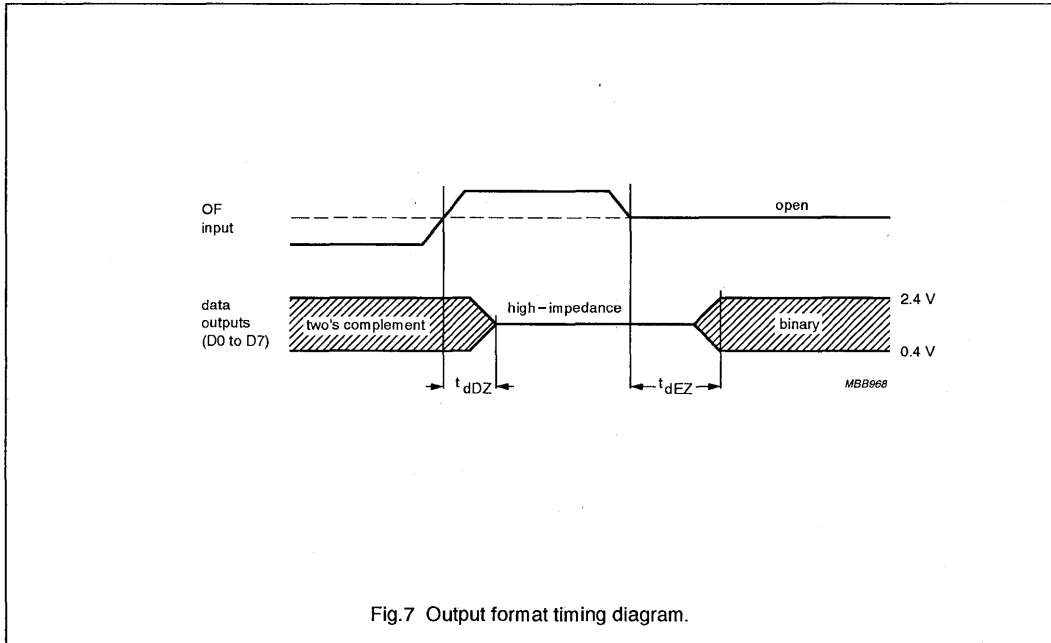

Fig.7 Output format timing diagram.

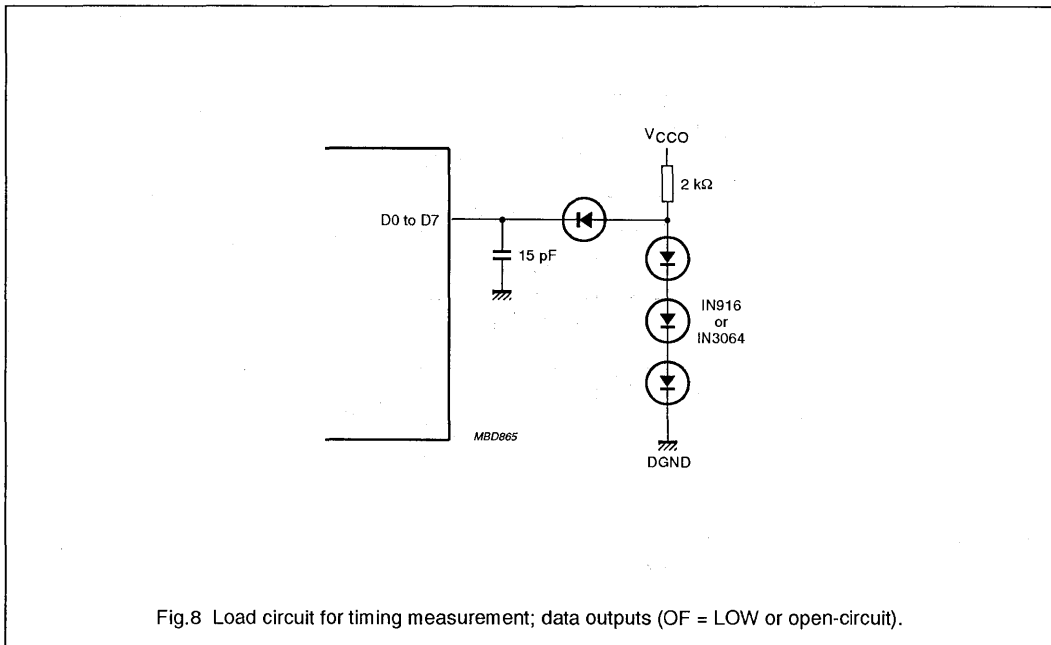

Fig.8 Load circuit for timing measurement; data outputs (OF = LOW or open-circuit).

Video analog input interface

TDA8708B

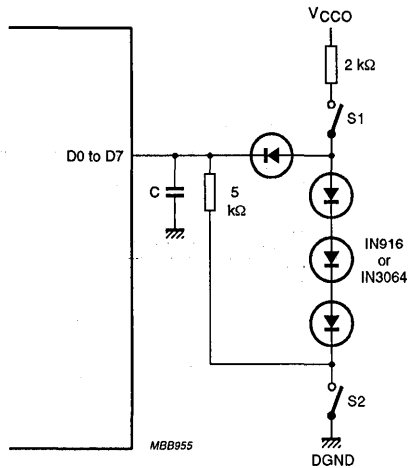
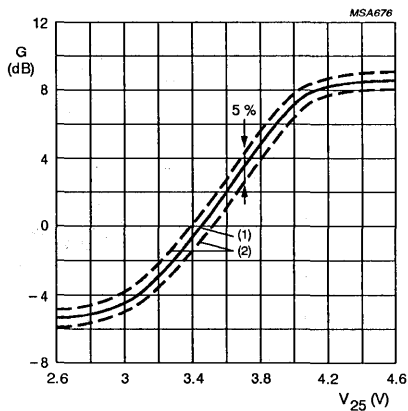

Fig.9 Load circuit for timing measurement; 3-state outputs (OF:  $f_i = 1$  MHz;  $V_{OF} = 3$  V).



- (1) Typical value ( $V_{CCA} = V_{CCD} = 5$  V;  $T_{amb} = 25$  °C).
- (2) Minimum and maximum values (temperature and supply).

Fig.10 Gain control curve.

Video analog input interface

TDA8708B

INTERNAL PIN CIRCUITRY

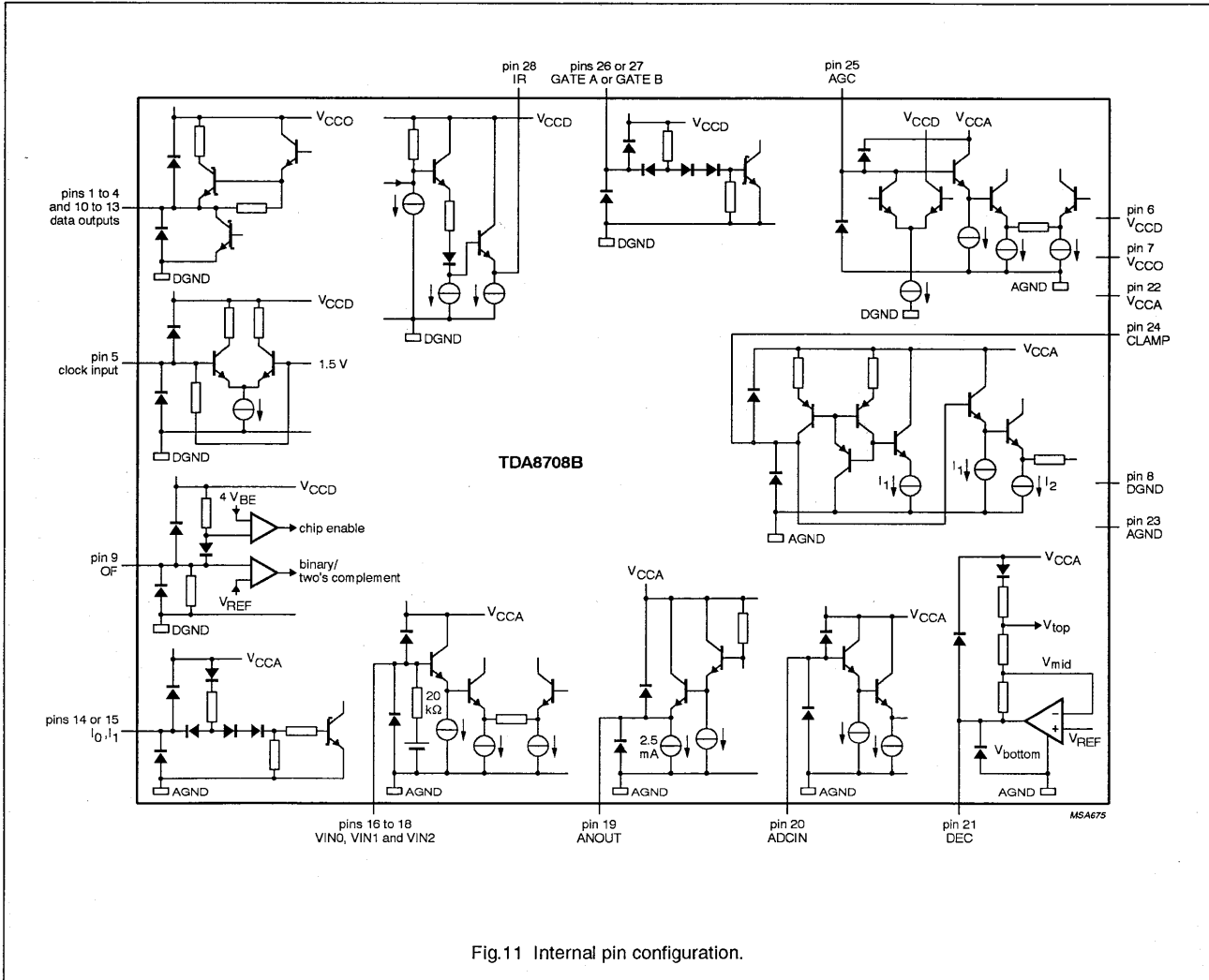

Fig.11 Internal pin configuration.

## Video analog input interface

## TDA8708B

## APPLICATION INFORMATION

Additional information can be found in the laboratory report of TDA8708A "FBL/AN9308".

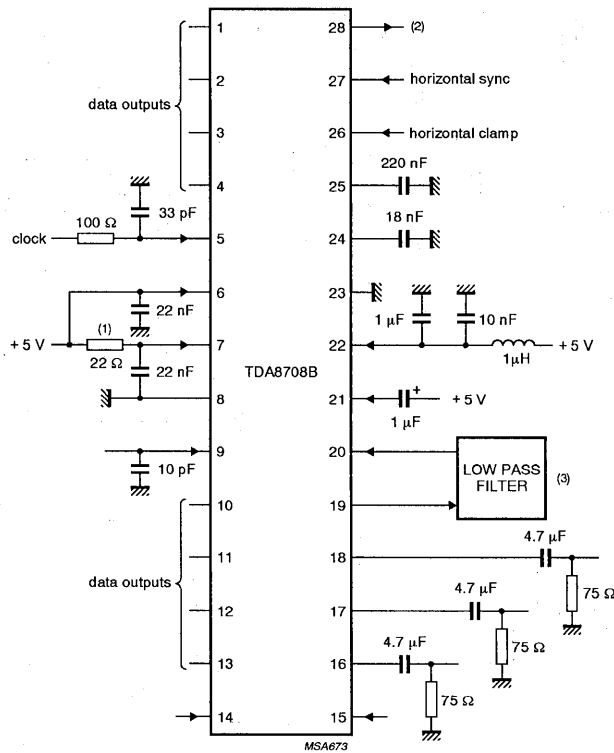

- (1) it is recommended to decouple  $V_{CC0}$  through a 22  $\Omega$  resistor especially when the output data of TDA8708B interfaces with a capacitive CMOS load device.
- (2) When IR is not used, it must be connected to ground via a 47 pF capacitor.
- (3) See Figs 13 and 15 for examples of the low-pass filters.

Fig.12 Application diagram.

Video analog input interface

TDA8708B

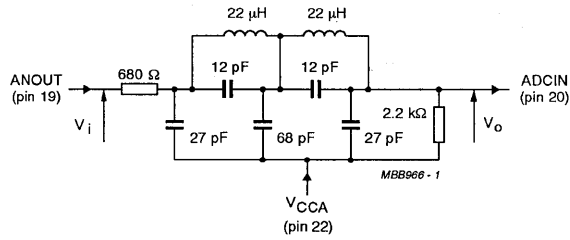

This filter can be adapted to various applications with respect to performance requirements. An input and output impedance of at least 680 Ω and 2.2 kΩ must in any event be applied.

Fig.13 Example of a low-pass filter for CVBS and Y signals.

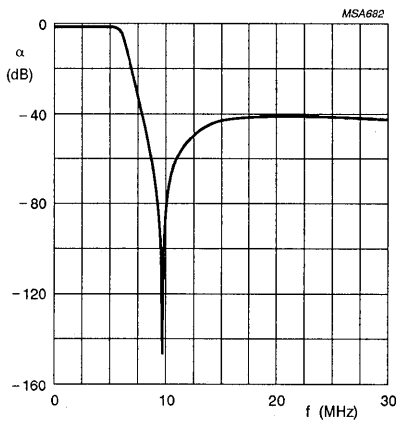

Fig.14 Frequency response for filter shown in Fig.13.

Characteristics of Fig.14

- Order 5; adapted CHEBYSHEV
- Ripple  $\rho \leq 0.4$  dB
- $f = 6.5$  MHz at  $-3$  dB
- $f_{\text{notch}} = 9.75$  MHz.

Video analog input interface

TDA8708B

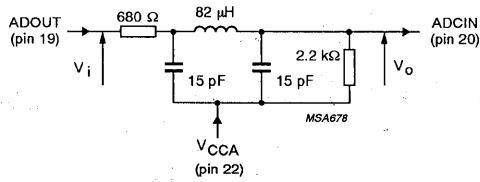

This filter can be adapted to various applications with respect to performance requirements. An input and output impedance of at least 680 Ω and 2.2 kΩ must in any event be applied.

Fig.15 Example of an economical low-pass filter for CVBS and Y signals.

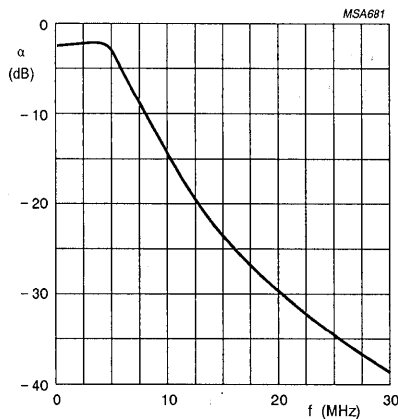

Fig.16 Frequency response for filter shown in Fig.15.

Characteristics of Fig.16

- Order 5; adapted CHEBYSHEV
- Ripple  $\rho \leq 0.4$  dB
- $f = 6.5$  MHz at  $-3$  dB.

## Video analog input interface

## TDA8709A

## FEATURES

- 8-bit resolution
- Sampling rate up to 32 MHz
- TTL-compatible digital inputs and outputs
- Internal reference voltage regulator
- Low-level AC clock inputs and outputs
- Clamp function with selection for '16' or '128'
- No sample-and-hold circuit required
- Three selectable video inputs.

## APPLICATIONS

- Video signal processing
- Digital picture processing
- Frame grabbing.
- Colour difference signals (U, V)
- R, G, B signals
- Chrominance signal (C).

## GENERAL DESCRIPTION

The TDA8709A is an analog input interface for video signal processing. It includes a an input selector (one out-of-three video signals), video amplifier with clamp and external gain control, an 8-bit analog-to-digital converter (ADC) with a sampling rate of 32 MHz and an input selector.

## QUICK REFERENCE DATA

SYMBOL	PARAMETER	MIN.	TYP.	MAX.	UNIT
V <sub>CCA</sub>	analog supply voltage	4.5	5.0	5.5	V
V <sub>CCD</sub>	digital supply voltage	4.5	5.0	5.5	V
V <sub>CCO</sub>	TTL output supply voltage	4.2	5.0	5.5	V
I <sub>CCA</sub>	analog supply current	–	40	47	mA
I <sub>CCD</sub>	digital supply current	–	24	30	mA
I <sub>CCO</sub>	TTL output supply current	–	12	16	mA
ILE	DC integral linearity error	–	–	±1	LSB
DLE	DC differential linearity error	–	–	±0.5	LSB
f <sub>clk(max)</sub>	maximum clock frequency	30	32	–	MHz
B	maximum –3 dB bandwidth (preamplifier)	12	18	–	MHz
P <sub>tot</sub>	total power dissipation	–	380	512	mW

## ORDERING INFORMATION

TYPE NUMBER	PACKAGE			
	PINS	PIN POSITION	MATERIAL	CODE
TDA8709A	28	DIP	plastic	SOT117-1
TDA8709AT	28	SO28L	plastic	SOT136-1

Video analog input interface

TDA8709A

BLOCK DIAGRAM

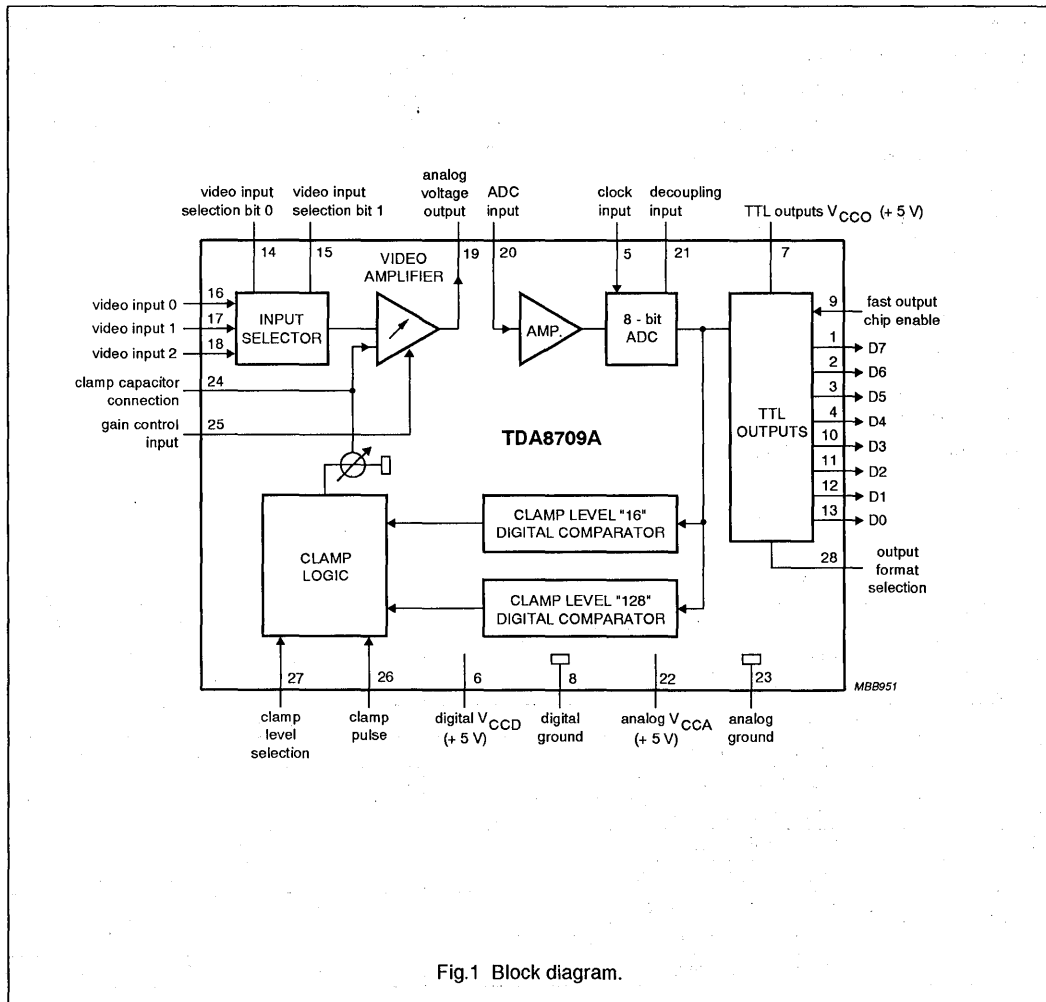

Fig.1 Block diagram.



## Video analog input interface

## TDA8709A

## PINNING

SYMBOL	PIN	DESCRIPTION
D7	1	data output; bit 7 (MSB)
D6	2	data output; bit 6
D5	3	data output; bit 5
D4	4	data output; bit 4
CLK	5	clock input
V <sub>CCD</sub>	6	digital supply voltage (+5 V)
V <sub>CCO</sub>	7	TTL outputs supply voltage (+5 V)
DGND	8	digital ground
FOEN	9	fast output chip enable
D3	10	data output; bit 3
D2	11	data output; bit 2
D1	12	data output; bit 1
D0	13	data output; bit 0 (LSB)
I0	14	video input selection bit 0
I1	15	video input selection bit 1
VIN0	16	video input 0
VIN1	17	video input 1
VIN2	18	video input 2
ANOUT	19	analog voltage output
ADCIN	20	analog-to-digital converter input
DEC	21	decoupling input
V <sub>CCA</sub>	22	analog supply voltage (+5 V)
AGND	23	analog ground
CLAMP	24	clamp capacitor connection
GAIN	25	gain control input
CLP	26	clamping pulse
CLS	27	clamping level selection input
OFS	28	output format selection

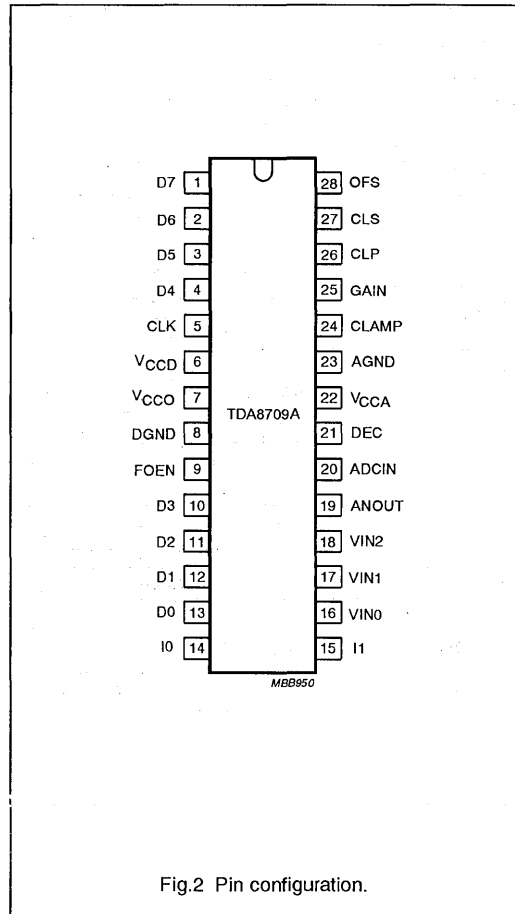

## Video analog input interface

## TDA8709A

**FUNCTIONAL DESCRIPTION**

TDA8709A is an 8-bit ADC with internal clamping and a preamplifier with adjustable gain.

The clamping value is switched via pin 27 between digital 16 (for R, G, B signals) and digital 128 (for

chrominance or colour difference signals). While clamping pulse at pin 27 is logic 1, the device will adjust the clamping level to the chosen value. The output format can be selected between binary and two's complement at pin 28.

**LIMITING VALUES**

In accordance with the Absolute Maximum Rating System (IEC 134).

SYMBOL	PARAMETER	MIN.	MAX.	UNIT
$V_{CCA}$	analog supply voltage	-0.3	+7.0	V
$V_{CCD}$	digital supply voltage	-0.3	+7.0	V
$V_{CCO}$	TTL output supply voltage	-0.3	+7.0	V
$\Delta V_{CC}$	supply voltage difference between $V_{CCA}$ and $V_{CCD}$	-0.5	+0.5	V
	supply voltage difference between $V_{CCO}$ and $V_{CCD}$	-0.5	+0.5	V
	supply voltage difference between $V_{CCA}$ and $V_{CCO}$	-1.0	+1.0	V
$V_I$	input voltage	-0.3	+7.0	V
$I_O$	output current	-	+10	mA
$T_{stg}$	storage temperature	-55	+150	°C
$T_{amb}$	operating ambient temperature	0	+70	°C
$T_j$	junction temperature	0	+125	°C

**THERMAL CHARACTERISTICS**

SYMBOL	PARAMETER	VALUE	UNIT
$R_{th\ j-a}$	thermal resistance from junction to ambient in free air		
	SOT117-1	55	K/W
	SOT136-1	70	K/W

## Video analog input interface

TDA8709A

**CHARACTERISTICS**

$V_{CCA} = V_{22}$  to  $V_{23} = 4.5$  to  $5.5$  V;  $V_{CCD} = V_6$  to  $V_8 = 4.5$  to  $5.5$  V;  $V_{CCO} = V_7$  to  $V_8 = 4.2$  to  $5.5$  V; AGND and DGND shorted together;  $V_{CCA}$  to  $V_{CCD} = -0.5$  to  $+0.5$  V;  $V_{CCO}$  to  $V_{CCD} = -0.5$  to  $+0.5$  V;  $V_{CCA}$  to  $V_{CCO} = -0.5$  to  $+0.5$  V;  $T_{amb} = 0$  to  $+70$  °C; typical readings taken at  $V_{CCA} = V_{CCD} = V_{CCO} = 5$  V and  $T_{amb} = 25$  °C; unless otherwise specified.

SYMBOL	PARAMETER	CONDITIONS	MIN.	TYP.	MAX.	UNIT
<b>Supplies</b>						
$V_{CCA}$	analog supply voltage		4.5	5.0	5.5	V
$V_{CCD}$	digital supply voltage		4.5	5.0	5.5	V
$V_{CCO}$	TTL output supply voltage		4.2	5.0	5.5	V
$I_{CCA}$	analog supply current		–	40	47	mA
$I_{CCD}$	digital supply current		–	24	30	mA
$I_{CCO}$	TTL output supply current	TTL load (see Fig.7)	–	12	16	mA
<b>Preamplifier inputs</b>						
VIN0 TO VIN2 INPUTS						
$V_{I(p-p)}$	input voltage (peak-to-peak value)	note 1	0.6	–	1.5	V
$ Z_i $	input impedance	$f_i = 6$ MHz	10	20	–	k $\Omega$
$C_i$	input capacitance	$f_i = 6$ MHz	–	1	–	pF
I0 AND I1 TTL INPUTS (SEE TABLE 1)						
$V_{IL}$	LOW level input voltage		0	–	0.8	V
$V_{IH}$	HIGH level input voltage		2.0	–	$V_{CCD}$	V
$I_{IL}$	LOW level input current	$V_i = 0.4$ V	–400	–	–	$\mu$ A
$I_{IH}$	HIGH level input current	$V_i = 2.7$ V	–	–	20	$\mu$ A
CLS, OFS AND CLP TTL INPUTS (SEE FIG.5)						
$V_{IL}$	LOW level input voltage		0	–	0.8	V
$V_{IH}$	HIGH level input voltage		2.0	–	$V_{CCD}$	V
$I_{IL}$	LOW level input current	$V_i = 0.4$ V	–400	–	–	$\mu$ A
$I_{IH}$	HIGH level input current	$V_i = 2.7$ V	–	–	20	$\mu$ A
$t_{CLP}$	clamp pulse width		2	–	–	$\mu$ s
GAIN INPUT (PIN 25)						
$V_{25(min)}$	input voltage for minimum gain	see Fig.9	–	1.8	–	V
$V_{25(max)}$	input voltage for maximum gain	see Fig.9	–	3.8	–	V
$I_i$	input current		–	1.0	–	$\mu$ A
CLAMP INPUT (PIN 24)						
$V_{24}$	clamp voltage for code 128 output		–	3.5	–	V
$I_{24}$	clamp output current		see Table 2			

## Video analog input interface

## TDA8709A

SYMBOL	PARAMETER	CONDITIONS	MIN.	TYP.	MAX.	UNIT
<b>Video amplifier outputs</b>						
ANOUT OUTPUT (PIN 19)						
$V_{19(p-p)}$	AC output voltage (peak-to-peak value)	$V_{OF} = 1.33 \text{ V (p-p)}$ ; $V_{25} = 3.0 \text{ V}$	–	1.33	–	V
$I_{19}$	internal current source	$R_L = \infty$	2.0	2.5	–	mA
$I_{O(p-p)}$	output current driven by the load	$V_{ANOUT} = 1.33 \text{ V (p-p)}$ ; note 2	–	–	1.0	mA
$V_{19}$	DC output voltage for black level	CLS = logic 1	–	$V_{CCA} - 2.02$	–	V
$V_{19}$	DC output voltage for black level	CLS = logic 0	–	$V_{CCA} - 2.6$	–	V
$Z_{19}$	output impedance		–	20	–	$\Omega$
<b>Preamplifier dynamic characteristics</b>						
$\alpha_{ct}$	crosstalk between VIN inputs	$V_{CCA} = 4.75 \text{ to } 5.25 \text{ V}$ ; note 3	–	–50	–45	dB
$G_{diff}$	differential gain	$V_{VIN} = 1.33 \text{ V (p-p)}$ ; $V_{25} = 3.0 \text{ V}$	–	2	–	%
$\varphi_{diff}$	differential phase	$V_{VIN} = 1.33 \text{ V (p-p)}$ ; $V_{25} = 3.0 \text{ V}$	–	0.8	–	deg
B	–3 dB bandwidth		12	–	–	MHz
S/N	signal-to-noise ratio	note 4	60	–	–	dB
SVRR1	supply voltage ripple rejection	note 5	–	45	–	dB
$\Delta G$	gain range	see Fig.9	–4.5	–	+6.0	dB
$G_{stab}$	gain stability as a function of supply voltage and temperature	see Fig.9	–	–	5	%
<b>Analog-to-digital converter inputs</b>						
CLK INPUT (PIN 5)						
$V_{IL}$	LOW level input voltage		0	–	0.8	V
$V_{IH}$	HIGH level input voltage		2.0	–	$V_{CCD}$	V
$I_{IL}$	LOW level input current	$V_{clk} = 0.4 \text{ V}$	–400	–	–	$\mu\text{A}$
$I_{IH}$	HIGH level input current	$V_{clk} = 2.7 \text{ V}$	–	–	100	$\mu\text{A}$
$ Z_i $	input impedance	$f_{clk} = 10 \text{ MHz}$	–	4	–	$\text{k}\Omega$
$C_1$	input capacitance	$f_{clk} = 10 \text{ MHz}$	–	4.5	–	pF
FOEN INPUT (SEE TABLE 3)						
$V_{IL}$	LOW level input voltage		0	–	0.8	V
$V_{IH}$	HIGH level input voltage		2.0	–	$V_{CCD}$	V
$I_{IL}$	LOW level input current	$V_9 = 0.4 \text{ V}$	–400	–	–	$\mu\text{A}$
$I_{IH}$	HIGH level input current	$V_9 = 2.7 \text{ V}$	–	–	20	$\mu\text{A}$

## Video analog input interface

## TDA8709A

SYMBOL	PARAMETER	CONDITIONS	MIN.	TYP.	MAX.	UNIT
<b>ADCIN INPUT (PIN 20; SEE TABLE 4)</b>						
$V_{20}$	input voltage	digital output = 00	-	$V_{CCA} - 2.52$	-	V
$V_{20}$	input voltage	digital output = 255	-	$V_{CCA} - 1.52$	-	V
$V_{20(p-p)}$	input voltage amplitude (peak-to-peak value)		-	1.0	-	V
$I_{20}$	input current		-	1.0	10	$\mu$ A
$ Z_i $	input impedance	$f_i = 6$ MHz	-	50	-	M $\Omega$
$C_i$	input capacitance	$f_i = 6$ MHz	-	1	-	pF
<b>Analog-to-digital converter outputs</b>						
DIGITAL OUTPUTS D0 TO D7						
$V_{OL}$	LOW level output voltage	$I_{OL} = 2$ mA	0	-	0.6	V
$V_{OH}$	HIGH level output voltage	$I_{OL} = -0.4$ mA	2.4	-	$V_{CCD}$	V
$I_{OZ}$	output current in 3-state mode	$0.4$ V < $V_O$ < $V_{CCD}$	-20	-	+20	$\mu$ A
<b>Switching characteristics</b>						
$f_{clk(max)}$	maximum clock input frequency	see Fig.5; note 6	30	32	-	MHz
<b>Analog signal processing (<math>f_{clk} = 32</math> MHz; see Fig.7)</b>						
$G_{diff}$	differential gain	$V_{20} = 1.0$ V (p-p); see Fig.6; note 7	-	2	-	%
$\varphi_{diff}$	differential phase	see Fig.6; note 7	-	2	-	deg
$f_1$	fundamental harmonics (full-scale)	$f_i = 4.43$ MHz; note 7	-	-	0	dB
$f_{all}$	harmonics (full-scale); all components	$f_i = 4.43$ MHz; note 7	-	-55	-	dB
SVRR2	supply voltage ripple rejection	note 8	-	1	5	%/V
<b>Transfer function</b>						
ILE	DC integral linearity error		-	-	$\pm 1$	LSB
DLE	DC differential linearity error		-	-	$\pm 0.5$	LSB
ILE	AC integral linearity error	note 9	-	-	$\pm 2$	LSB
<b>Timing (<math>f_{clk} = 32</math> MHz; see Figs 5, 6 and 7)</b>						
DIGITAL OUTPUTS ( $C_L = 15$ pF; $I_{OL} = 2$ mA; $R_L = 2$ k $\Omega$ )						
$t_{ds}$	sampling delay time		-	2	-	ns
$t_h$	output hold time		-	8	-	ns
$t_d$	output delay time		-	16	20	ns
$t_{dEZ}$	3-state delay time; output enable		-	16	25	ns
$t_{dDZ}$	3-state delay time; output disable		-	12	25	ns

## Video analog input interface

## TDA8709A

**Notes to the "Characteristics"**

1. 0 dB is obtained at the AGC amplifier when applying  $V_{i(p-p)} = 1.33$  V.
2. The output current at pin 19 should not exceed 1 mA. The load impedance  $R_L$  should be referenced to  $V_{CCA}$  and defined as:
  - a) AC impedance  $\geq 1$  k $\Omega$  and the DC impedance  $> 2.7$  k $\Omega$ .
  - b) The load impedance should be coupled directly to the output of the amplifier so that the DC voltage supplied by the clamp is not disturbed.
3. Input signals with the same amplitude. Gain is adjusted to obtain  $ANOUT = 1.33$  V (p-p).

4. Signal-to-noise ratio measured with 5 MHz bandwidth:

$$\frac{S}{N} = 20 \log \frac{V_{ANOUT(p-p)}}{V_{ANOUT(RMS\ noise)}} \text{ at } B = 5 \text{ MHz.}$$

5. The voltage ratio is expressed as:

$$SVRR1 = 20 \log \frac{\Delta V_{CCA}}{V_{CCA}} \times \frac{G}{\Delta G} \text{ for } V_i = 1 \text{ V (p-p), gain at 100 kHz} = 1 \text{ and 1 V supply variation.}$$

6. It is recommended that the rise and fall times of the clock are  $\geq 2$  ns. In addition, a 'good layout' for the digital and analog grounds is recommended.
7. These measurements are realized on analog signals after a digital-to-analog conversion (TDA8702 is used).
8. The supply voltage rejection is the relative variation of the analog signal (full-scale signal at input) for 1 V of supply variation:

$$SVRR2 = \frac{\Delta (V_{I(00)} - V_{I(FF)}) + (V_{I(00)} - V_{I(FF)})}{\Delta V_{CCA}}$$

9. Full-scale sine wave ( $f_i = 4.4$  MHz;  $f_{clk} = 27$  MHz).

Video analog input interface

TDA8709A

**Table 1** Video input selection (CVBS).

I1	I0	SELECTED INPUT
0	0	VIN0
0	1	VIN1
1	0	VIN2
1	1	VIN1

**Table 3** FOEN input coding.

FOEN	D0 TO D7
0	active, two's complement
1	high impedance

**Table 2** CLAMP output current.

CLS	CLP	DIGITAL OUTPUT	I <sub>CLAMP</sub>
1	1	output < 128	+50 μA
		output > 128	-50 μA
X <sup>(1)</sup>	0	X	0 μA
0	1	output < 16	+50 μA
		16 < output	-50 μA

**Note**

1. X = don't care.

**Table 4** Output coding and input voltage (typical values).

STEP	V <sub>ADCIN</sub>	BINARY OUTPUTS								TWO'S COMPLEMENT							
		D7	D6	D5	D4	D3	D2	D1	D0	D7	D6	D5	D4	D3	D2	D1	D0
Underflow	-	0	0	0	0	0	0	0	0	1	0	0	0	0	0	0	0
0	V <sub>CCA</sub> - 2.52 V	0	0	0	0	0	0	0	0	1	0	0	0	0	0	0	0
1	-	0	0	0	0	0	0	0	1	1	0	0	0	0	0	0	1
.	-	.	.	.	.	.	.	.	.	.	.	.	.	.	.	.	.
.	-	.	.	.	.	.	.	.	.	.	.	.	.	.	.	.	.
254	-	1	1	1	1	1	1	1	0	0	1	1	1	1	1	1	0
255	V <sub>CCA</sub> - 1.52 V	1	1	1	1	1	1	1	1	0	1	1	1	1	1	1	1
Overflow	-	1	1	1	1	1	1	1	1	0	1	1	1	1	1	1	1

Video analog input interface

TDA8709A

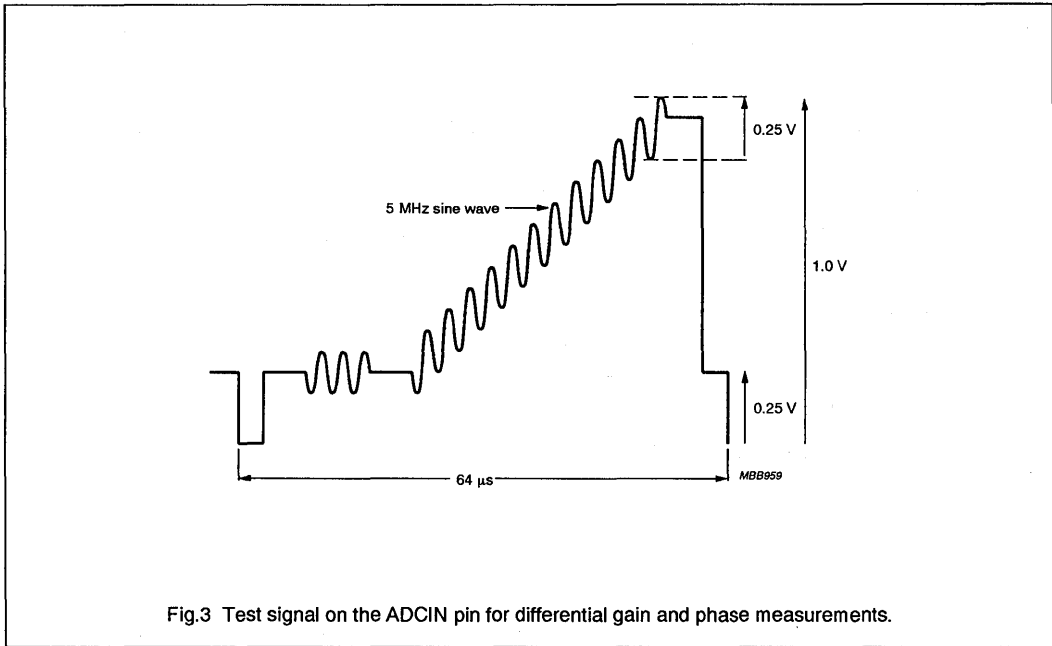

Fig.3 Test signal on the ADCIN pin for differential gain and phase measurements.

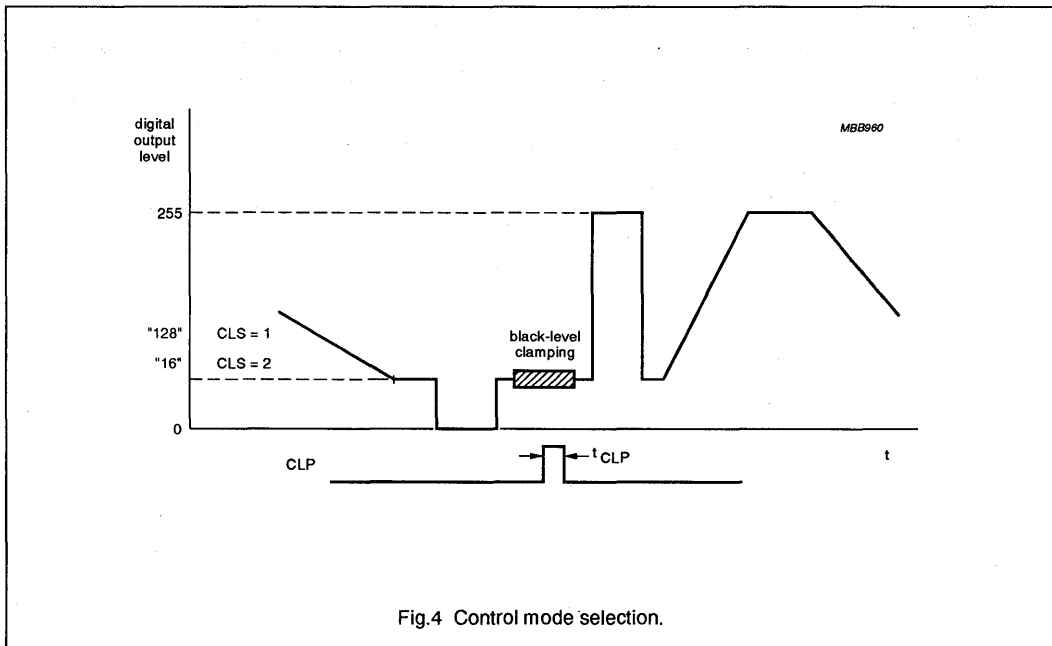

Fig.4 Control mode selection.



Video analog input interface

TDA8709A

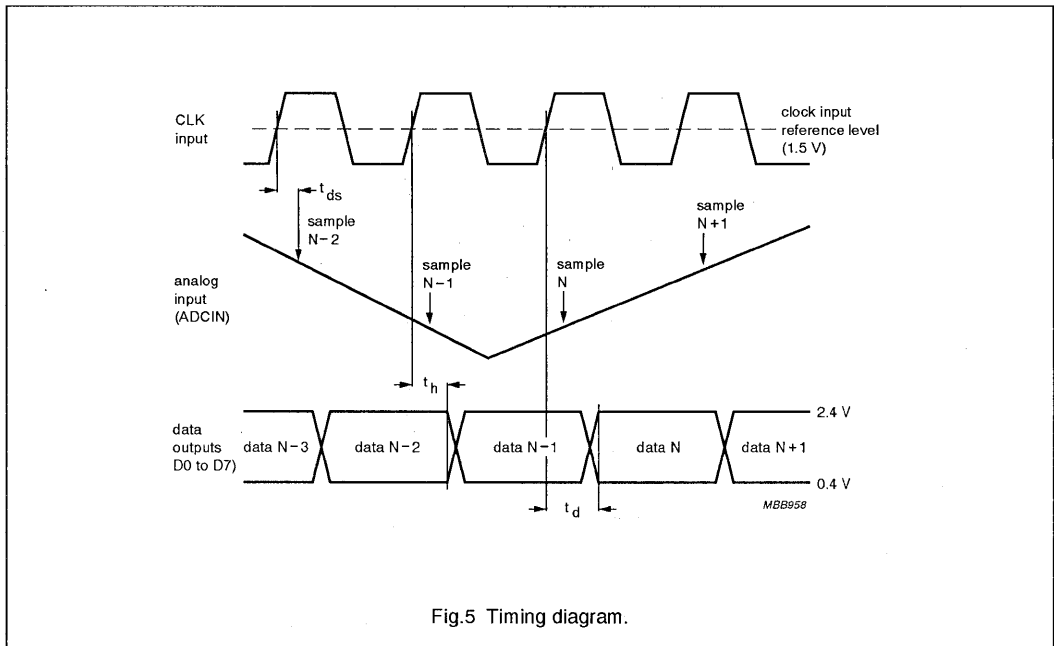

Fig.5 Timing diagram.

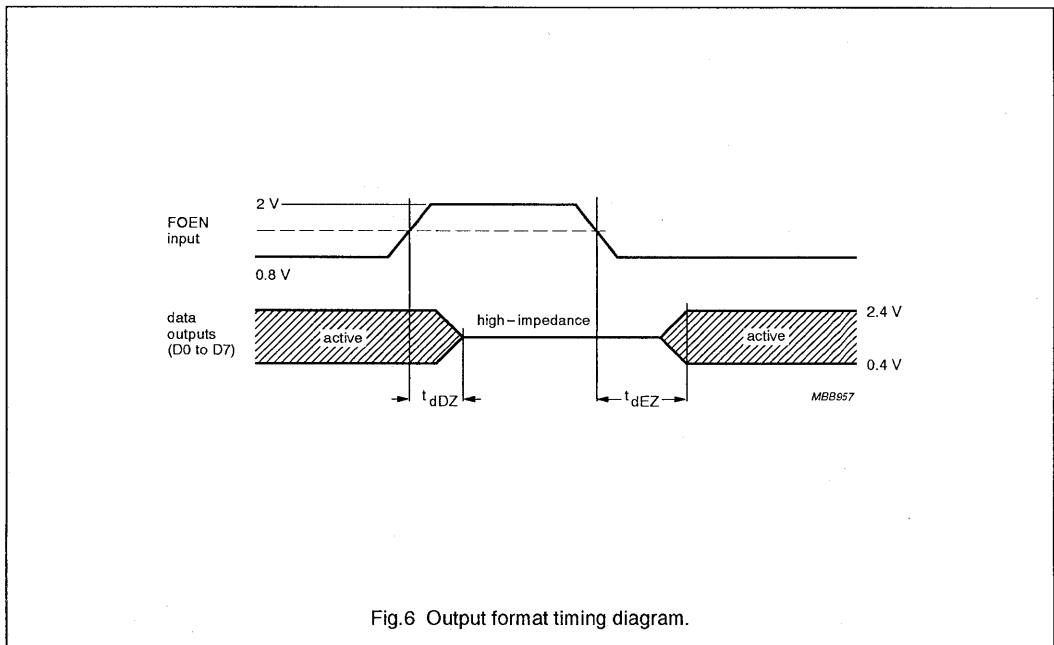

Fig.6 Output format timing diagram.

Video analog input interface

TDA8709A

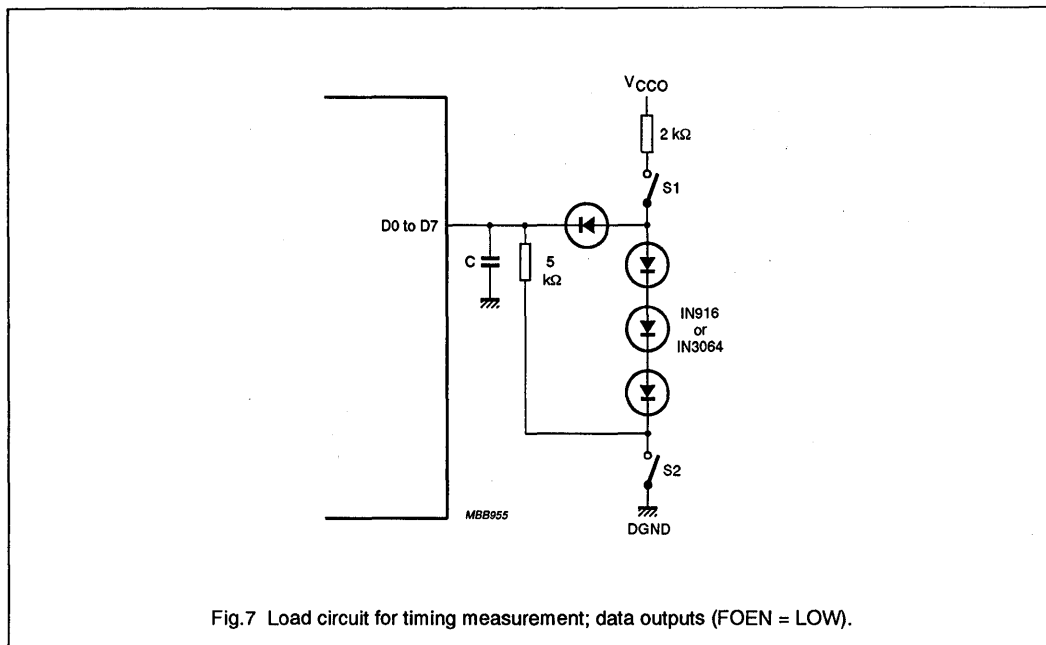

Fig.7 Load circuit for timing measurement; data outputs (FOEN = LOW).

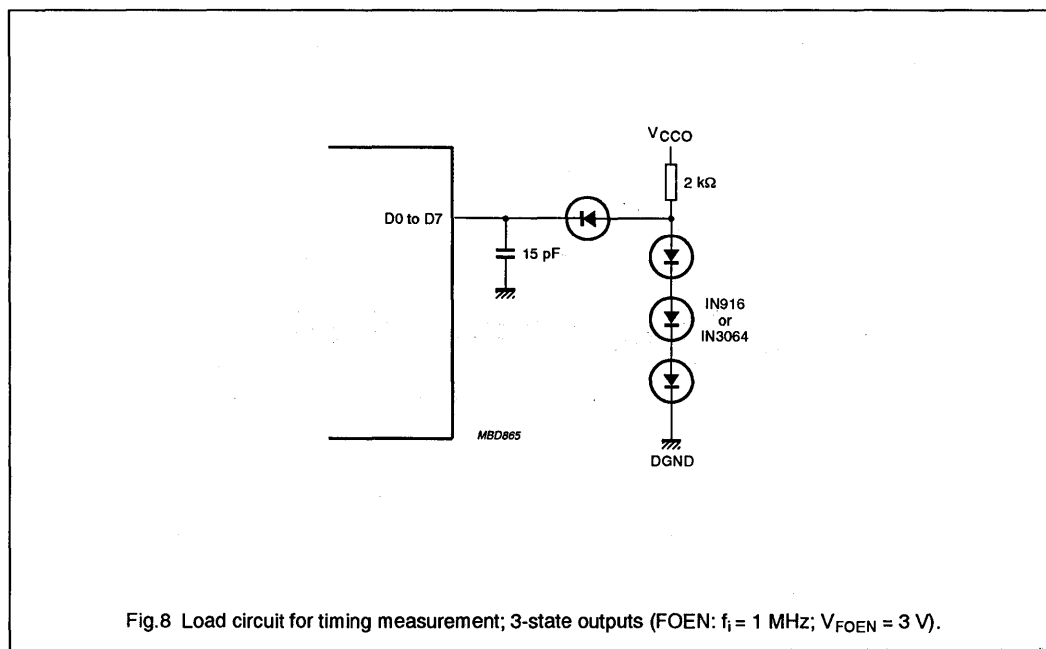
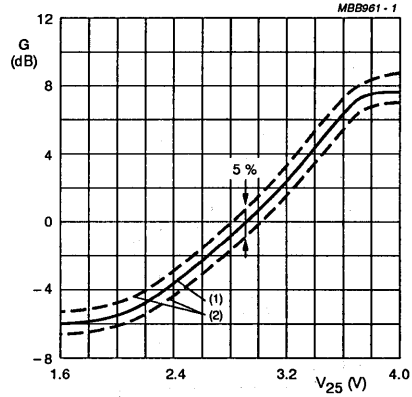

Fig.8 Load circuit for timing measurement; 3-state outputs (FOEN:  $f_1 = 1 \text{ MHz}$ ;  $V_{FOEN} = 3 \text{ V}$ ).

Video analog input interface

TDA8709A



- (1) Typical value ( $V_{CCA} = V_{CCD} = 5\text{ V}$ ;  $T_{amb} = 25\text{ }^\circ\text{C}$ ).
- (2) Minimum and maximum values (temperature and supply).

Fig.9 Typical gain control curve as a function of gain voltage.

Video analog input interface

TDA8709A

INTERNAL PIN CIRCUITRY

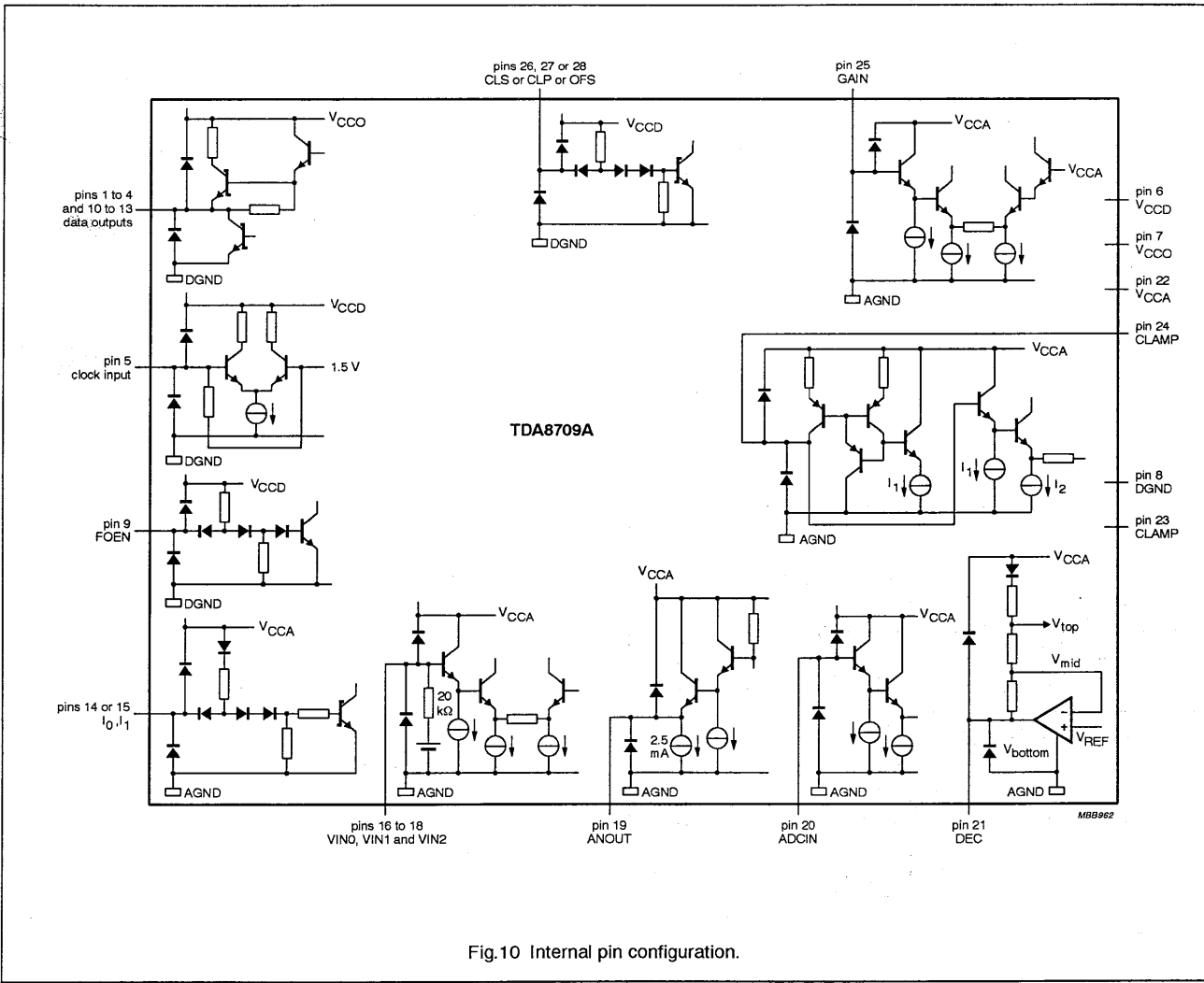

Fig.10 Internal pin configuration.

Video analog input interface

TDA8709A

APPLICATION INFORMATION

Additional information can be found in the laboratory report of TDA8708A "FBL/AN9308".

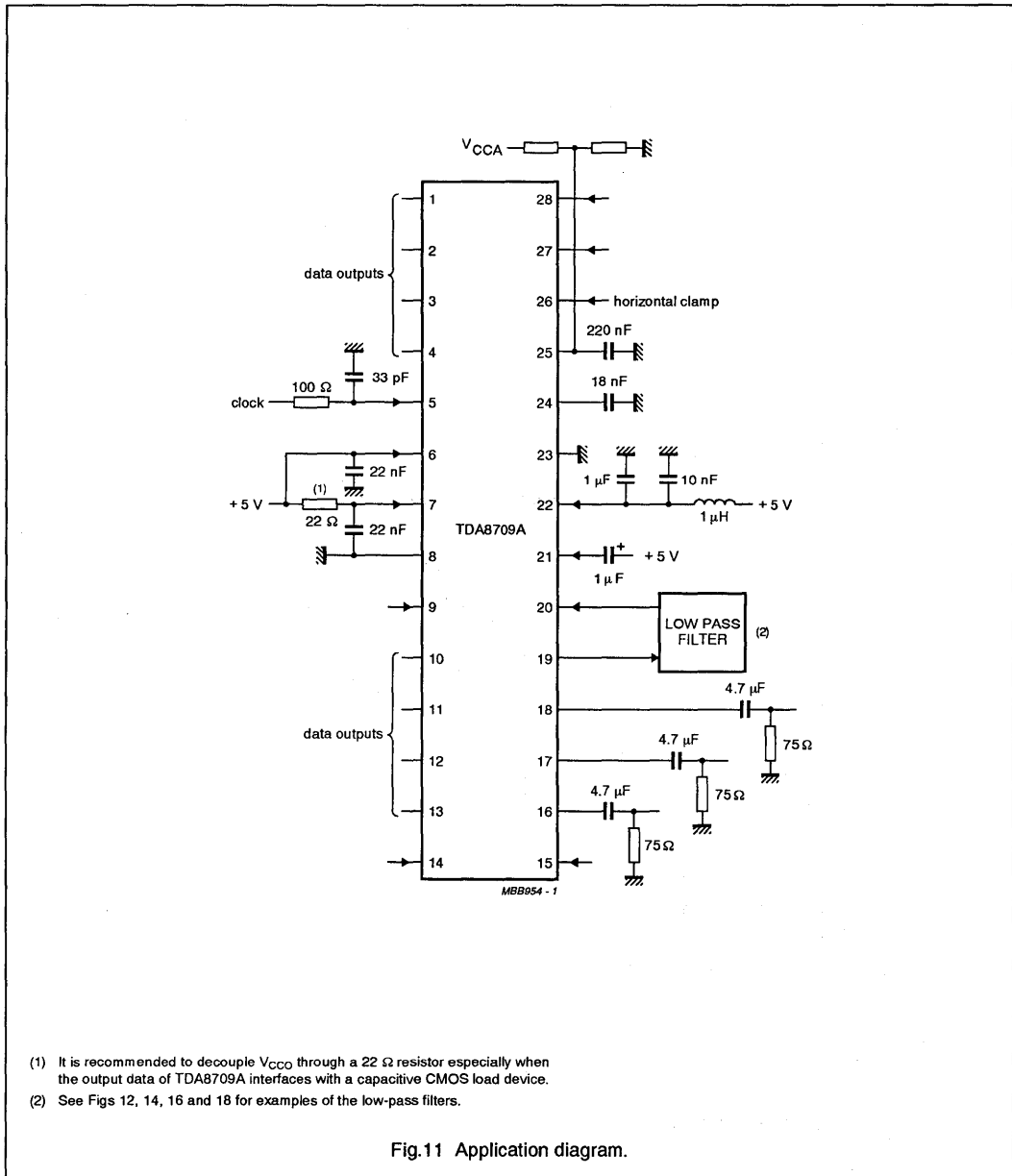

(1) It is recommended to decouple V<sub>CCO</sub> through a 22 Ω resistor especially when the output data of TDA8709A interfaces with a capacitive CMOS load device.

(2) See Figs 12, 14, 16 and 18 for examples of the low-pass filters.

Fig.11 Application diagram.

Video analog input interface

TDA8709A

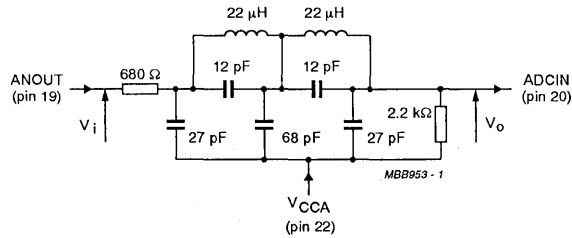

This filter can be adapted to various applications with respect to performance requirements. An input and output impedance of at least 680 Ω and 2.2 kΩ must in any event be applied.

Fig.12 Example of a low-pass filter for RGB and C signals.

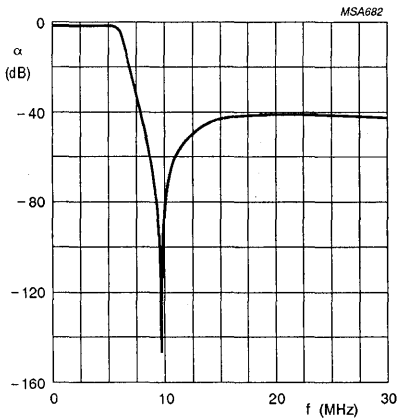

Fig.13 Frequency response for filter shown in Fig.12.

Characteristics of Fig.13

- Order 5; adapted CHEBYSHEV
- Ripple  $\rho \leq 0.4$  dB
- $f = 6.5$  MHz at  $-3$  dB
- $f_{\text{notch}} = 9.65$  MHz.

## Video analog input interface

## TDA8709A

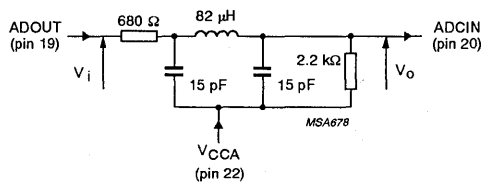

This filter can be adapted to various applications with respect to performance requirements. An input and output impedance of at least 680  $\Omega$  and 2.2 k $\Omega$  must in any event be applied.

Fig.14 Example of an economical low-pass filter for RGB and C signals.

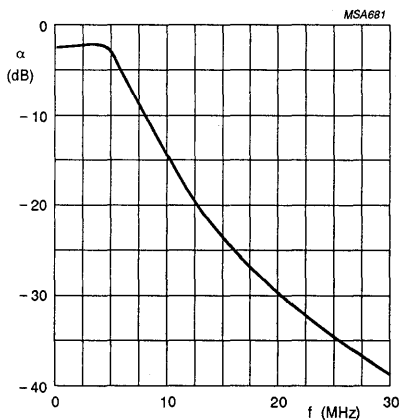

Fig.15 Frequency response for filter shown in Fig.14.

#### Characteristics of Fig.15

- Order 3; adapted CHEBYSHEV
- Ripple  $\rho \leq 0.4$  dB
- $f = 6.5$  MHz at  $-3$  dB.

Video analog input interface

TDA8709A

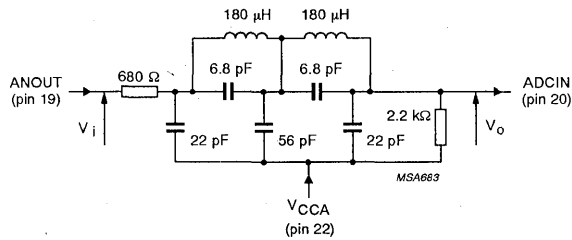

This filter can be adapted to various applications with respect to performance requirements. An input and output impedance of at least 680 Ω and 2.2 kΩ must in any event be applied.

Fig.16 Example of a low-pass filter for U and V signals.

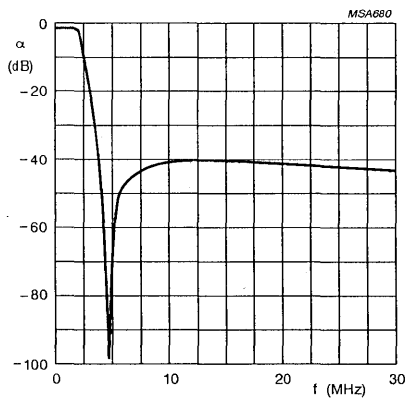

Fig.17 Frequency response for filter shown in Fig.16.

Characteristics of Fig.17

- Order 5; adapted CHEBYSHEV
- Ripple  $\rho \leq 0.4$  dB
- $f = 2.3$  MHz at  $-3$  dB
- $f_{\text{notch}} = 4.5$  MHz.



Video analog input interface

TDA8709A

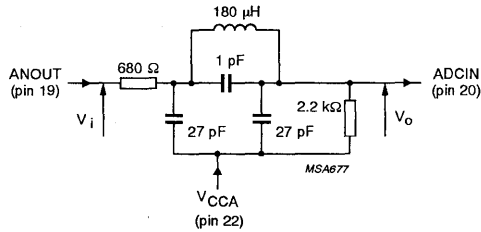

This filter can be adapted to various applications with respect to performance requirements. An input and output impedance of at least 680 Ω and 2.2 kΩ must in any event be applied.

Fig.18 Example of an economical low-pass filter for U and V signals.

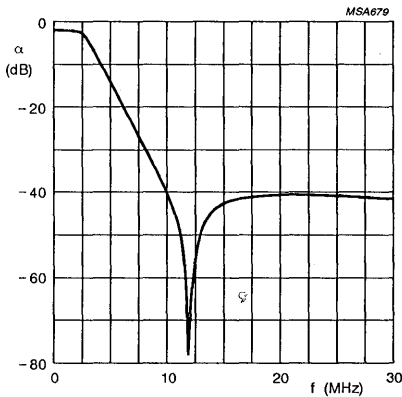

Fig.19 Frequency response for filter shown in Fig.18.

Characteristics of Fig.19

- Order 3; adapted CHEBYSHEV
- Ripple  $\rho \leq 0.3$  dB
- $f = 2.8$  MHz at  $-3$  dB
- $f_{\text{notch}} = 11.9$  MHz.

**8-bit digital-to-analog converters****TDA8712; TDF8712****FEATURES**

- 8-bit resolution
- Conversion rate up to 50 MHz
- TTL input levels
- Internal reference voltage generator
- Two complementary analog voltage outputs
- No deglitching circuit required
- Internal input register
- Low power dissipation
- Internal 75  $\Omega$  output load (connected to the analog supply)
- Very few external components required
- Temperature range
  - TDA8712: 0 to 70 °C
  - TDF8712: -40 to +85 °C.

**APPLICATIONS**

- High-speed digital-to-analog conversion
- Digital TV including:
  - field progressive scan
  - line progressive scan
- Subscriber TV decoders
- Satellite TV decoders
- Digital VCRs
- Industrial and automotive.

**GENERAL DESCRIPTION**

The TDA8712 and TDF8712 are 8-bit digital-to-analog converters (DACs) for video and other applications. They convert the digital input signal into an analog voltage output at a maximum conversion rate of 50 MHz. No external reference voltage is required and all digital inputs are TTL compatible.

**ORDERING INFORMATION**

TYPE NUMBER	PACKAGE			
	PINS	PIN POSITION	MATERIAL	CODE
TDA8712	16	DIP	plastic	SOT38-1
TDF8712	16	DIP	plastic	SOT38-1
TDA8712T	16	SO16L	plastic	SOT162-1
TDF8712T	16	SO16L	plastic	SOT162-1

## 8-bit digital-to-analog converters

## TDA8712; TDF8712

## QUICK REFERENCE DATA

SYMBOL	PARAMETER	CONDITIONS	MIN.	TYP.	MAX.	UNIT
V <sub>CCA</sub>	analog supply voltage					
	TDA8712		4.5	5.0	5.5	V
	TDF8712		4.75	5.0	5.25	V
V <sub>CCD</sub>	digital supply voltage					
	TDA8712		4.5	5.0	5.5	V
	TDF8712		4.75	5.0	5.25	V
I <sub>CCA</sub>	analog supply current	note 1	20	26	32	mA
I <sub>CCD</sub>	digital supply current	note 1	16	23	30	mA
ΔV <sub>OUT(p-p)</sub>	full-scale analog output voltage differences between V <sub>OUT</sub> and $\bar{V}_{OUT}$ (peak-to-peak value)	Z <sub>L</sub> = 10 kΩ; note 2	-1.45	-1.60	-1.75	V
		Z <sub>L</sub> = 75 Ω; note 2	-0.72	0.80	-0.88	V
ILE	DC integral linear error		-	±0.3	±0.5	LSB
DLE	DC differential linearity error		-	±0.3	±0.5	LSB
f <sub>clk(max)</sub>	maximum conversion rate		50	-	-	MHz
B	-3 dB analog bandwidth	f <sub>clk</sub> = 50 MHz; note 3	-	150	-	MHz
P <sub>tot</sub>	total power dissipation					
	TDA8712		160	250	340	mW
	TDF8712		170	250	325	mW

## Notes

- D0 to D7 are connected to V<sub>CCD</sub> and CLK is connected to DGND.
- The analog output voltages (V<sub>OUT</sub> and  $\bar{V}_{OUT}$ ) are negative with respect to V<sub>CCA</sub> (see Table 1). The output resistance between V<sub>CCA</sub> and each of these outputs is typically 75 Ω.
- The -3 dB analog output bandwidth is determined by real time analysis of the output transient at a maximum input code transition (code 0 to 255).

8-bit digital-to-analog converters

TDA8712; TDF8712

BLOCK DIAGRAM

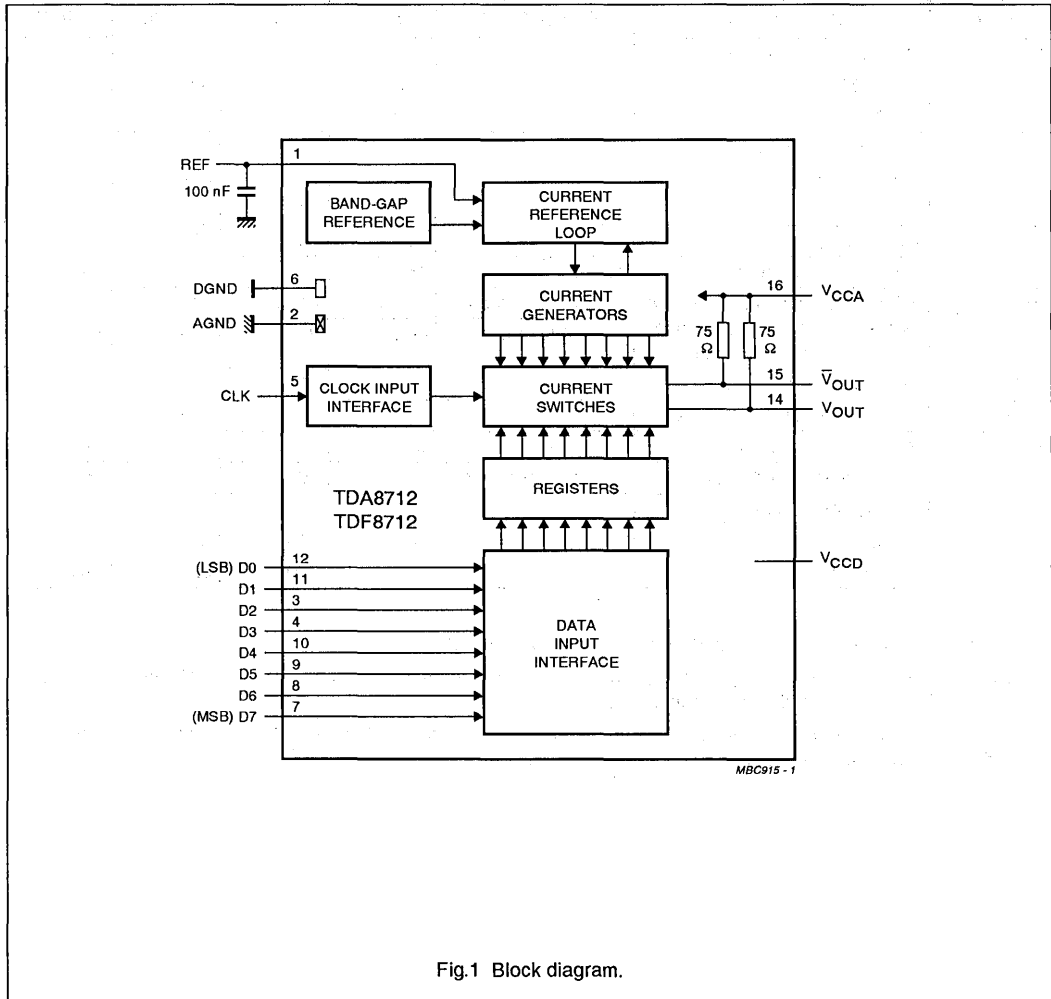

Fig.1 Block diagram.

8-bit digital-to-analog converters

TDA8712; TDF8712

PINNING

SYMBOL	PIN	DESCRIPTION
REF	1	voltage reference (decoupling)
AGND	2	analog ground
D2	3	data input; bit 2
D3	4	data input; bit 3
CLK	5	clock input
DGND	6	digital ground
D7	7	data input; bit 7 (MSB)
D6	8	data input; bit 6
D5	9	data input; bit 5
D4	10	data input; bit 4
D1	11	data input; bit 1
D0	12	data input; bit 0 (LSB)
V <sub>CCD</sub>	13	digital supply voltage (+5 V)
V <sub>OUT</sub>	14	analog output voltage
$\bar{V}_{OUT}$	15	complimentary analog output voltage
V <sub>CCA</sub>	16	analog supply voltage (+5 V)

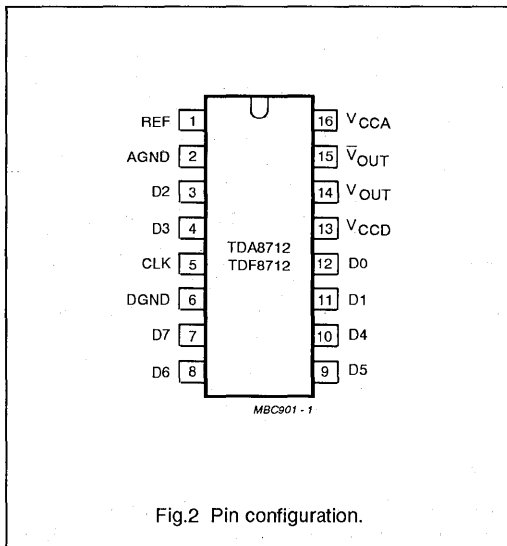

Fig.2 Pin configuration.

## 8-bit digital-to-analog converters

## TDA8712; TDF8712

**LIMITING VALUES**

In accordance with the Absolute Maximum Rating System (IEC134).

SYMBOL	PARAMETER	MIN.	MAX.	UNIT
$V_{CCA}$	analog supply voltage	-0.3	+7.0	V
$V_{CCD}$	digital supply voltage	-0.3	+7.0	V
$\Delta V_{CC}$	supply voltage differences between $V_{CCA}$ and $V_{CCD}$	-0.5	+0.5	V
$\Delta V_{GND}$	ground voltage differences between $V_{AGND}$ and $V_{DGND}$	-0.1	+0.1	V
$V_I$	input voltage (pins 3 to 5 and 7 to 12)	-0.3	$V_{CCD}$	V
$I_{tot}$	total output current ( $I_{OUT} + \bar{I}_{OUT}$ ; pins 14 and 15)	-5	+26	mA
$T_{stg}$	storage temperature	-55	+150	°C
$T_{amb}$	operating ambient temperature			
	TDA8712	0	+70	°C
	TDF8712	-40	+85	°C
$T_j$	junction temperature	-	+150	°C

**HANDLING**

Inputs and outputs are protected against electrostatic discharges in normal handling. However, to be totally safe, it is desirable to take normal precautions appropriate to handling integrated circuits.

**THERMAL CHARACTERISTICS**

SYMBOL	PARAMETER	VALUE	UNIT
$R_{th\ j-a}$	thermal resistance from junction to ambient in free air		
	SOT38-1	70	K/W
	SOT162-1	90	K/W

## 8-bit digital-to-analog converters

## TDA8712; TDF8712

**CHARACTERISTICS**

$V_{CCA} = V_{16}$  to  $V_2 = 4.5$  to  $5.5$  V (TDA8712) =  $4.75$  to  $5.25$  V (TDF8712);  $V_{CCD} = V_{13}$  to  $V_6 = 4.5$  to  $5.5$  V (TDA8712) =  $4.75$  to  $5.25$  V (TDF8712);  $V_{CCA}$  to  $V_{CCD} = -0.5$  to  $+0.5$  V (TDA8712) =  $-0.25$  to  $+0.25$  V (TDF8712); REF decoupled to AGND via a 100 nF capacitor;  $T_{amb} = -40$  to  $+85$  °C; AGND and DGND shorted together; typical readings taken at  $V_{CCA} = V_{CCD} = 5$  V and  $T_{amb} = 25$  °C; unless otherwise specified.

SYMBOL	PARAMETER	CONDITIONS	MIN.	TYP.	MAX.	UNIT
<b>Supply</b>						
$V_{CCA}$	analog supply voltage					
	TDA8712		4.5	5.0	5.5	V
	TDF8712		4.75	5.0	5.25	V
$V_{CCD}$	digital supply voltage					
	TDA8712		4.5	5.0	5.5	V
	TDF8712		4.75	5.0	5.25	V
$I_{CCA}$	analog supply current	note 1	20	26	32	mA
$I_{CCD}$	digital supply current	note 1	16	23	30	mA
$\Delta V_{GND}$	ground voltage differences between $V_{AGND}$ and $V_{DGND}$		-0.1	-	+0.1	V
<b>Inputs</b>						
DIGITAL INPUTS (D7 TO D0) AND CLOCK INPUT CLK						
$V_{IL}$	LOW level input voltage		0	-	0.8	V
$V_{IH}$	HIGH level input voltage		2.0	-	$V_{CCD}$	V
$I_{IL}$	LOW level input current	$V_I = 0.4$ V	-	-0.3	-0.4	mA
$I_{IH}$	HIGH level input current	$V_I = 2.7$ V	-	0.01	20	$\mu$ A
$f_{clk(max)}$	maximum clock frequency		50	-	-	MHz
<b>Outputs (referenced to <math>V_{CCA}</math>)</b>						
$\Delta V_{OUT(p-p)}$	full-scale analog output voltage differences between $V_{OUT}$ and $\bar{V}_{OUT}$ (peak-to-peak value)	$Z_L = 10$ k $\Omega$ ; note 2	-1.45	-1.60	-1.75	V
		$Z_L = 75$ $\Omega$ ; note 2	-0.72	0.80	-0.88	V
$V_{os}$	analog offset output voltage	code = 0	-	-3	-25	mV
$TC_{VOUT}$	full-scale analog output voltage temperature coefficient		-	-	200	$\mu$ V/K
$TC_{Vos}$	analog offset output voltage temperature coefficient		-	-	20	$\mu$ V/K
B	-3 dB analog bandwidth	$f_{clk} = 50$ MHz; note 3	-	150	-	MHz
$G_{diff}$	differential gain		-	0.6	-	%
$\Phi_{diff}$	differential phase		-	1	-	deg
$Z_o$	output impedance		-	75	-	$\Omega$
<b>Transfer function (<math>f_{clk} = 50</math> MHz)</b>						
ILE	DC integral linear error		-	$\pm 0.3$	$\pm 0.5$	LSB
DLE	DC differential linearity error		-	$\pm 0.3$	$\pm 0.5$	LSB

## 8-bit digital-to-analog converters

## TDA8712; TDF8712

SYMBOL	PARAMETER	CONDITIONS	MIN.	TYP.	MAX.	UNIT
<b>Switching characteristics (<math>f_{\text{clk}} = 50 \text{ MHz}</math>; notes 4 and 5; see Figs 3, 4 and 5)</b>						
$t_{\text{SU,DAT}}$	data set-up time		-0.3	-	-	ns
$t_{\text{HD,DAT}}$	data hold time		2.0	-	-	ns
$t_{\text{PD}}$	propagation delay time		-	-	1.0	ns
$t_{\text{S1}}$	settling time 1	10% to 90% full-scale change to $\pm 1 \text{ LSB}$	-	1.1	1.5	ns
$t_{\text{S2}}$	settling time 2	10% to 90% full-scale change to $\pm 1 \text{ LSB}$	-	6.5	8.0	ns
$t_{\text{d}}$	input to 50% output delay time		-	3.0	5.0	ns
<b>Output transients (glitches; <math>f_{\text{clk}} = 50 \text{ MHz}</math>; note 6; see Fig.6)</b>						
$E_{\text{g}}$	glitch energy from code	transition 127 to 128	-	-	30	LSB-ns

**Notes**

1. D0 to D7 are connected to  $V_{\text{CCD}}$  and CLK is connected to DGND.
2. The analog output voltages ( $V_{\text{OUT}}$  and  $\bar{V}_{\text{OUT}}$ ) are negative with respect to  $V_{\text{CCA}}$  (see Table 1). The output resistance between  $V_{\text{CCA}}$  and each of these outputs is typically  $75 \Omega$ .
3. The  $-3 \text{ dB}$  analog output bandwidth is determined by real time analysis of the output transient at a maximum input code transition (code 0 to 255).
4. The worst case characteristics are obtained at the transition from input code 0 to 255 and if an external load impedance greater than  $75 \Omega$  is connected between  $V_{\text{OUT}}$  or  $\bar{V}_{\text{OUT}}$  and  $V_{\text{CCA}}$ . The specified values have been measured with an active probe between  $V_{\text{OUT}}$  and AGND. No further load impedance between  $V_{\text{OUT}}$  and AGND has been applied. All input data is latched at the rising edge of the clock. The output voltage remains stable (independent of input data variations) during the HIGH level of the clock (CLK = HIGH). During a LOW-to-HIGH transition of the clock (CLK = LOW), the DAC operates in the transparent mode (input data will be directly transferred to their corresponding analog output voltages; see Fig.5).
5. The data set-up time ( $t_{\text{SU,DAT}}$ ) is the minimum period preceding the rising edge of the clock that the input data must be stable in order to be correctly registered. A negative set-up time indicates that the data may be initiated after the rising edge of the clock and still be recognized. The data hold time ( $t_{\text{HD,DAT}}$ ) is the minimum period following the rising edge of the clock that the input data must be stable in order to be correctly registered. A negative hold time indicates that the data may be released prior to the rising edge of the clock and still be recognized.
6. The definition of glitch energy and the measurement set-up are shown in Fig.6. The glitch energy is measured at the input transition between code 127 and 128 and on the falling edge of the clock.



8-bit digital-to-analog converters

TDA8712; TDF8712

**Table 1** Input coding and output voltages (typical values; referenced to  $V_{CCA}$ , regardless of the offset voltage).

CODE	INPUT DATA (D7 to D0)	DAC OUTPUT VOLTAGES (V)			
		$Z_L = 10\text{ k}\Omega$		$Z_L = 75\ \Omega$	
		$V_{OUT}$	$\bar{V}_{OUT}$	$V_{OUT}$	$\bar{V}_{OUT}$
0	000 00 00	0	-1.6	0	-0.8
1	000 000 01	-0.006	-1.594	-0.003	-0.797
.	.	.	.	.	.
128	100 000 00	-0.8	-0.8	-0.4	-0.4
.	.	.	.	.	.
254	111 111 10	-1.594	-0.006	-0.797	-0.003
255	111 111 11	-1.6	0	-0.8	0

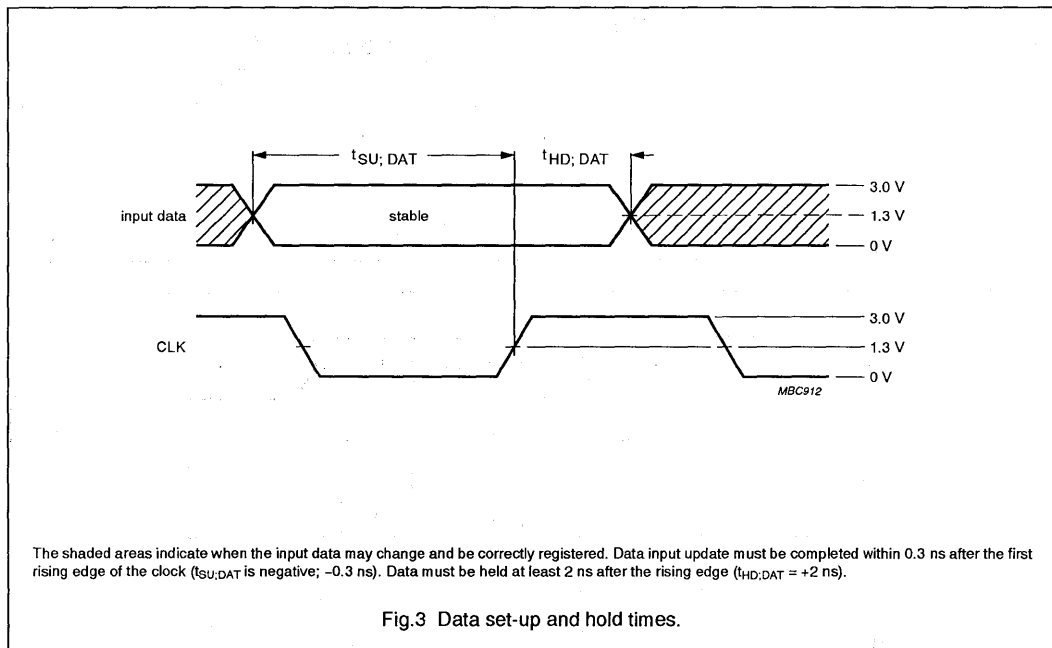

8-bit digital-to-analog converters

TDA8712; TDF8712

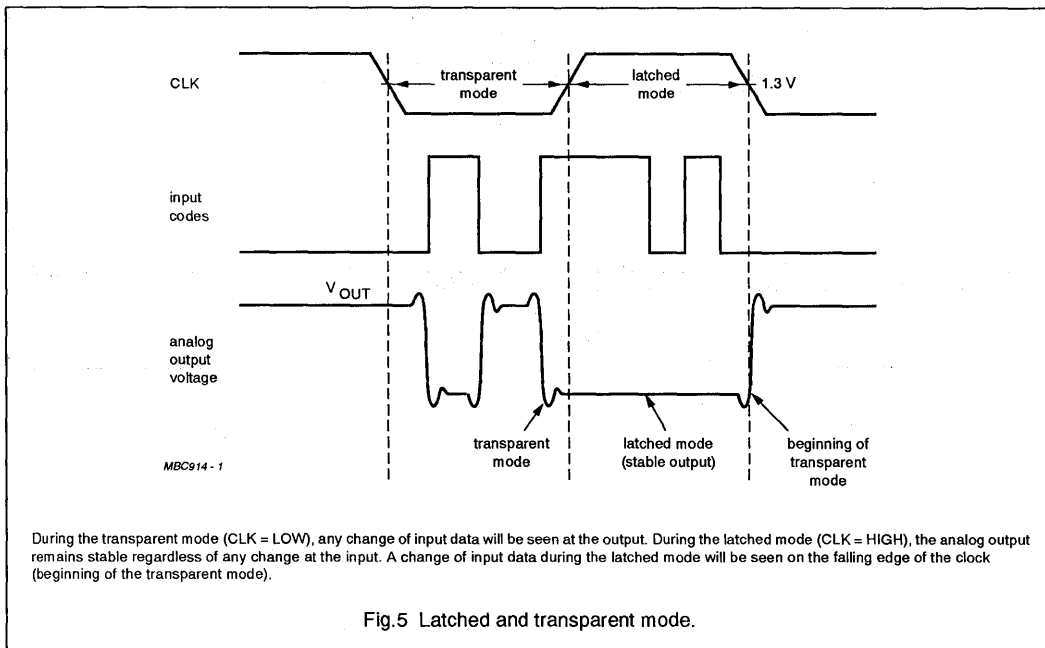
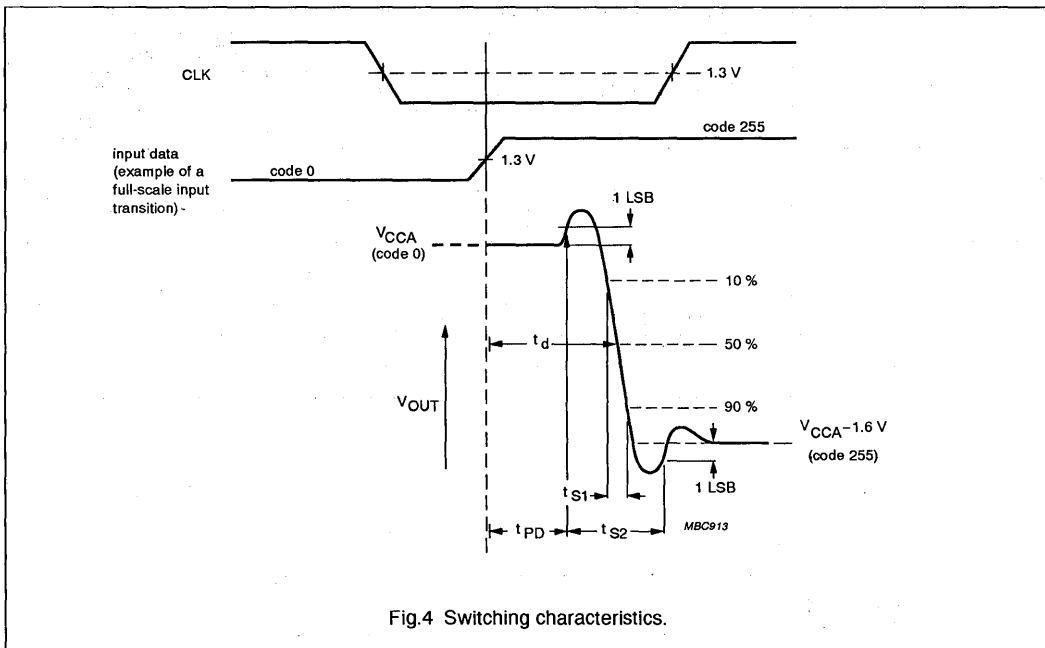

8-bit digital-to-analog converters

TDA8712; TDF8712

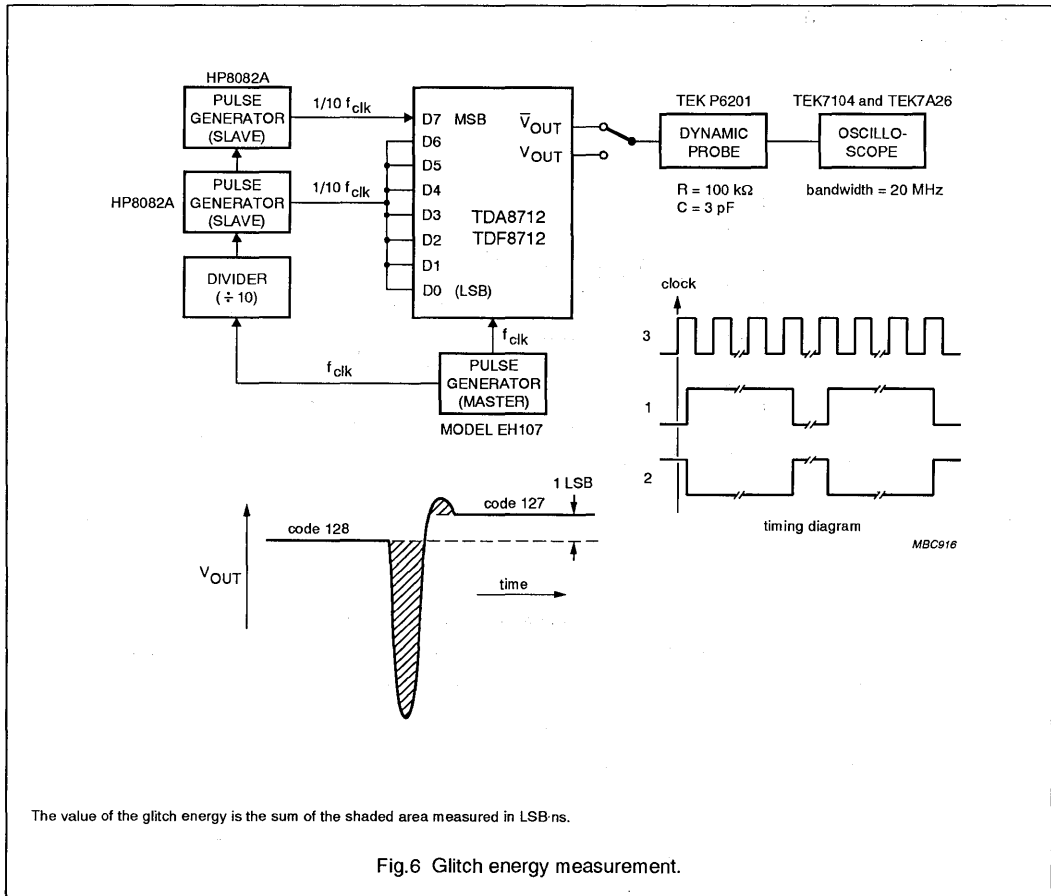

8-bit digital-to-analog converters

TDA8712; TDF8712

INTERNAL PIN CONFIGURATIONS

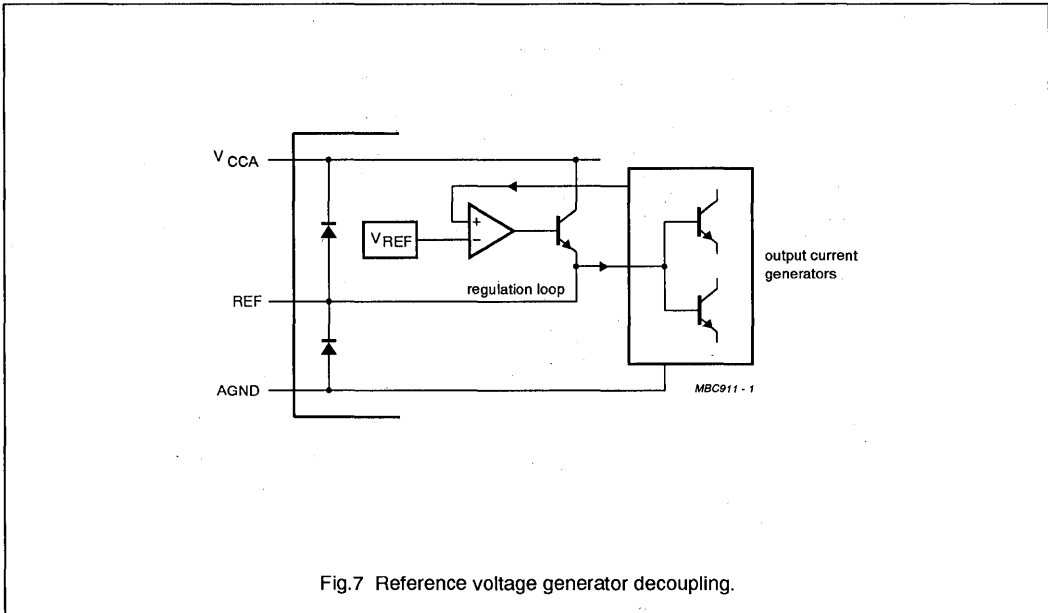

Fig.7 Reference voltage generator decoupling.

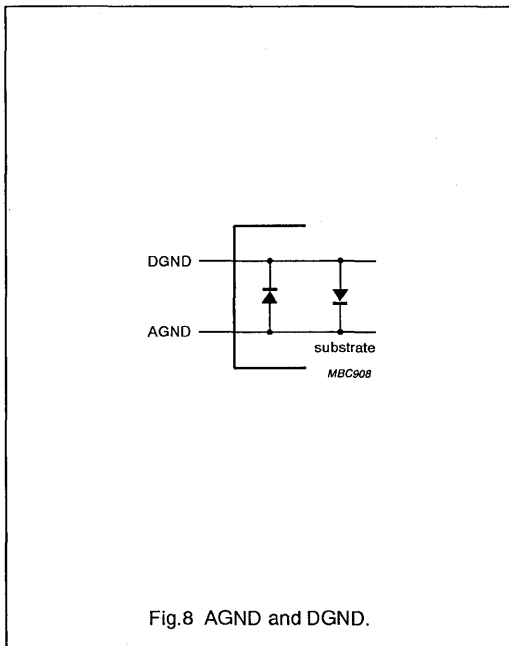

Fig.8 AGND and DGND.

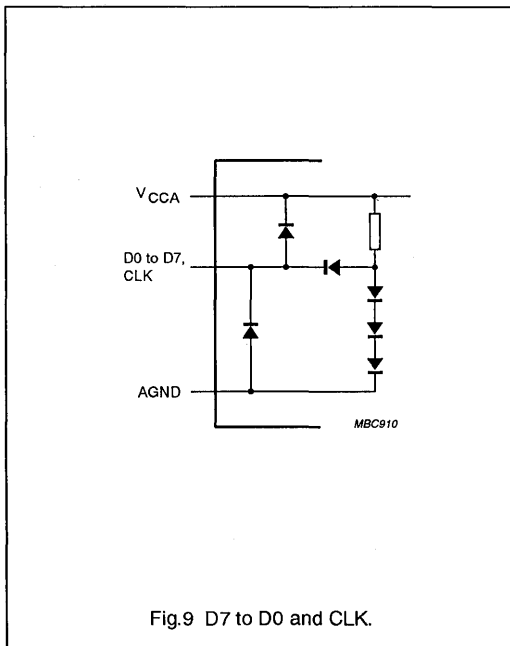
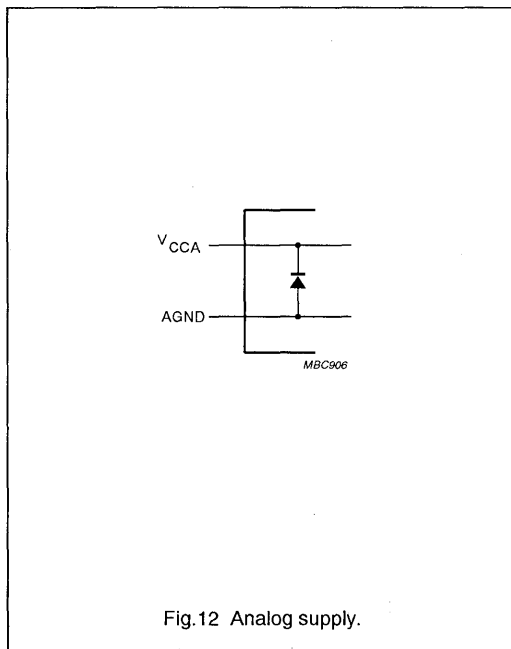
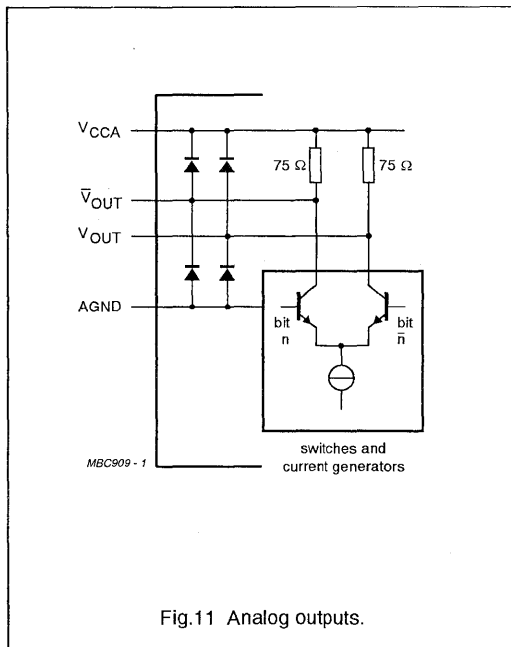
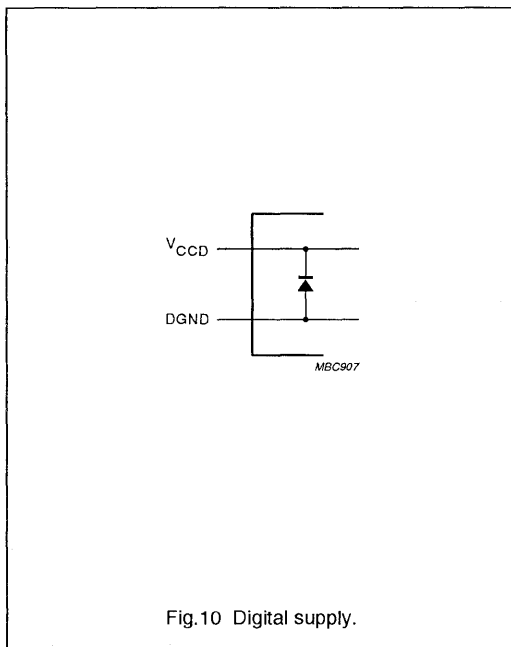

Fig.9 D7 to D0 and CLK.

8-bit digital-to-analog converters

TDA8712; TDF8712



8-bit digital-to-analog converters

TDA8712; TDF8712

APPLICATION INFORMATION

Additional application information can be supplied on request (please quote "FTV/8901").

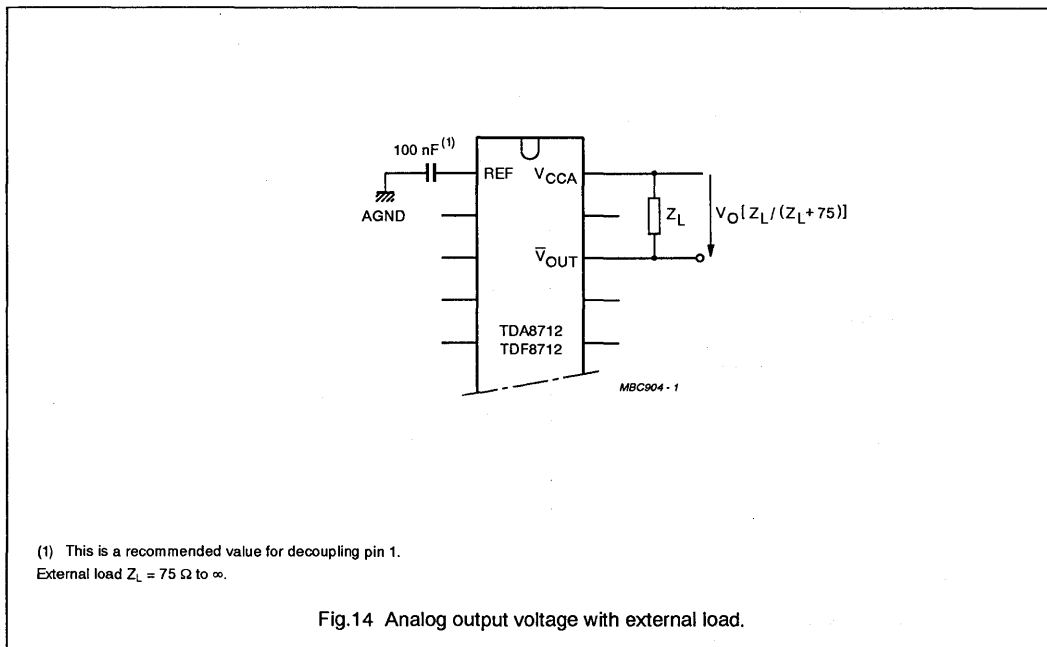
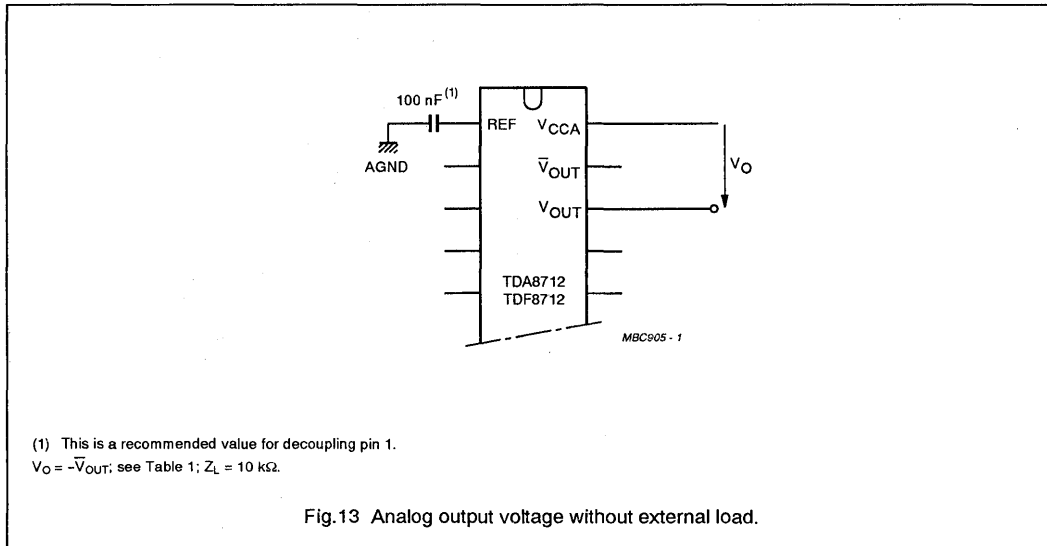

8-bit digital-to-analog converters

TDA8712; TDF8712

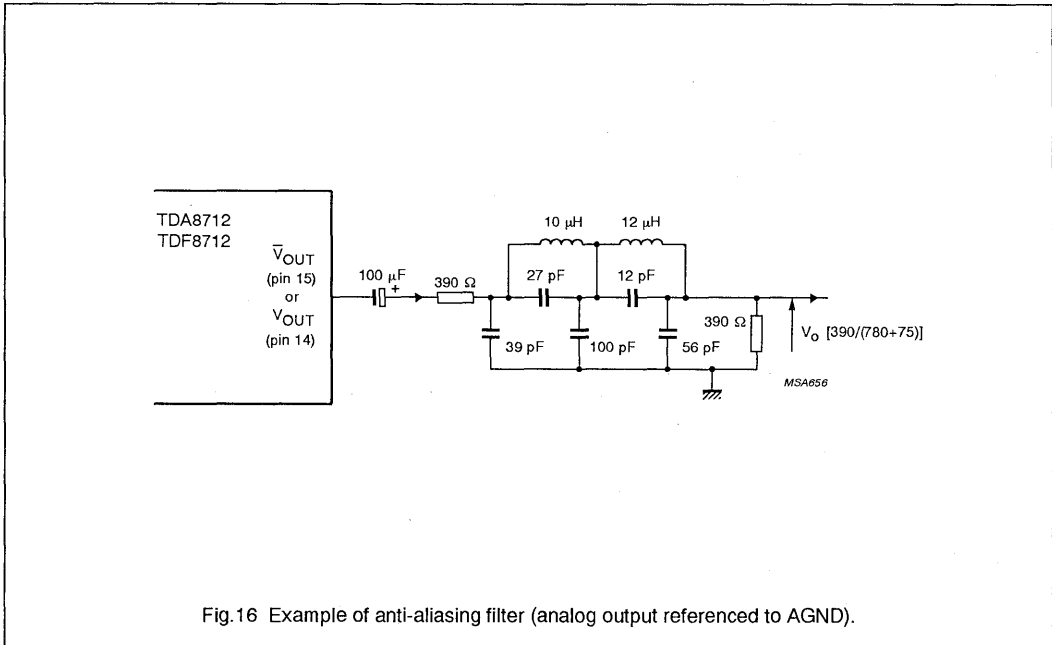
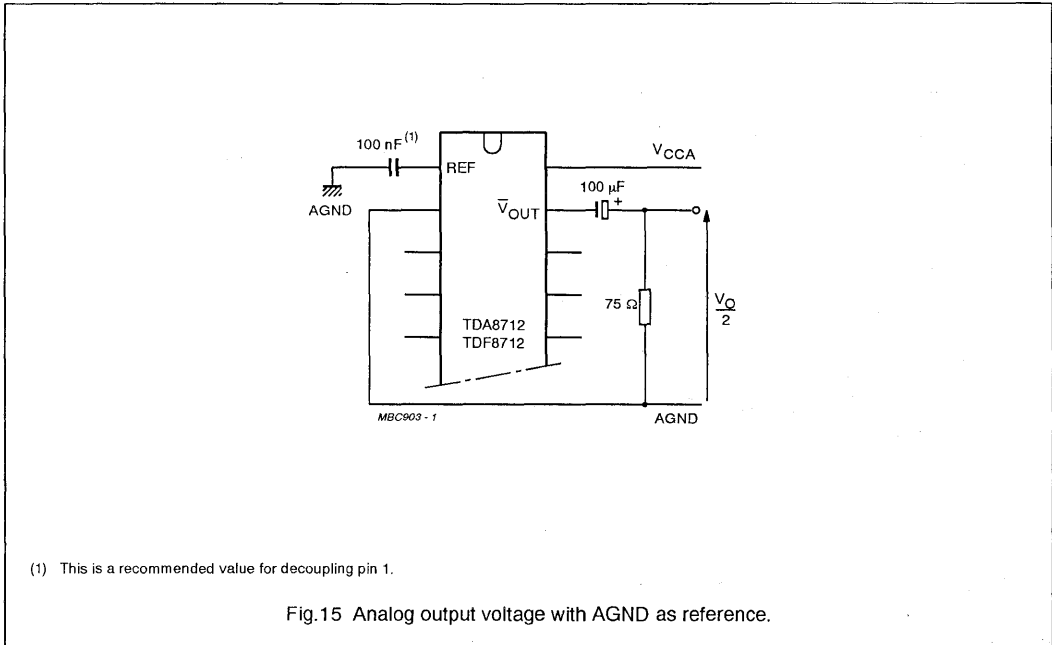

8-bit digital-to-analog converters

TDA8712; TDF8712

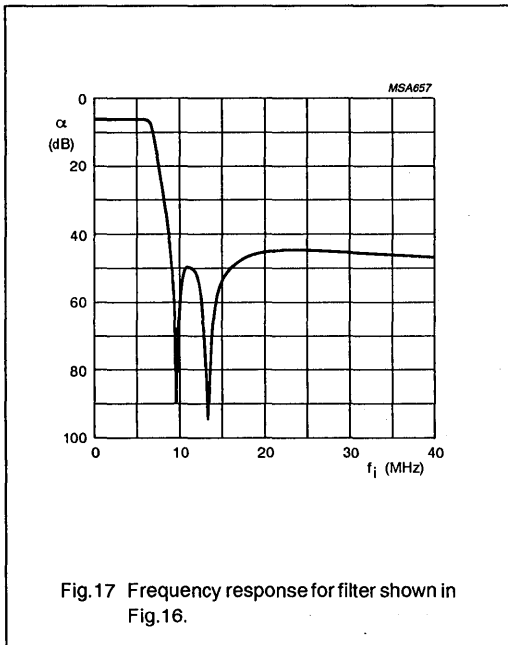
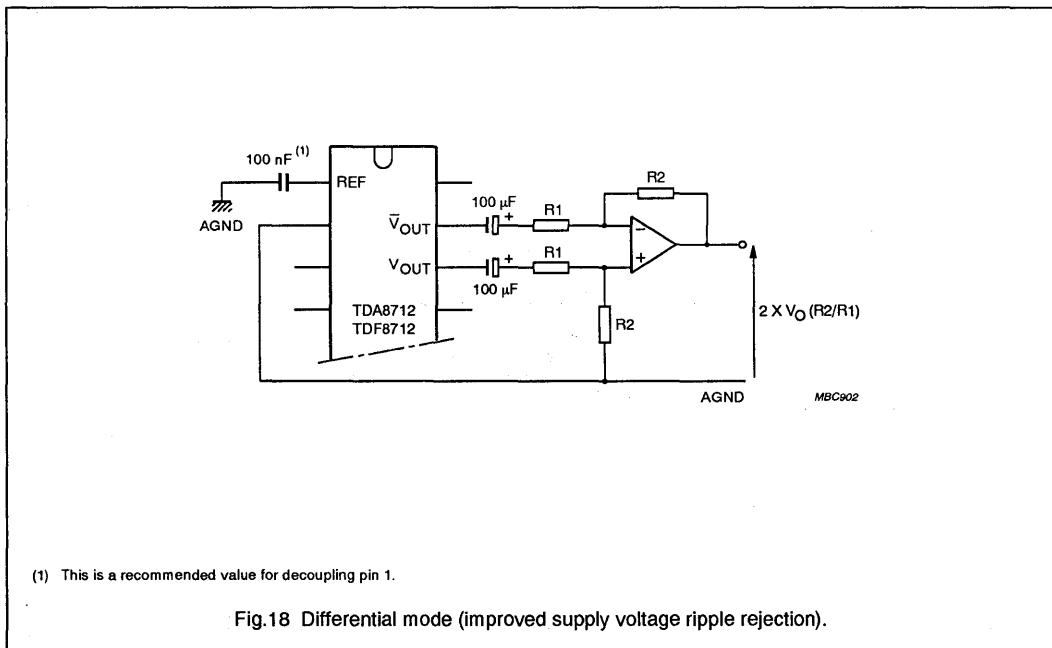

Fig.17 Frequency response for filter shown in Fig.16.

**Characteristics of Fig. 17**

- Order 5; adapted CHEBYSHEV
- Ripple  $\rho \leq 0.1$  dB
- $f = 6.7$  MHz at  $-3$  dB
- $f_{\text{notch}} = 9.7$  MHz and 13.3 MHz.



(1) This is a recommended value for decoupling pin 1.

Fig.18 Differential mode (improved supply voltage ripple rejection).



## 8-bit high-speed analog-to-digital converter

## TDA8714

## FEATURES

- 8-bit resolution
- Sampling rate up to 75 MHz
- High signal-to-noise ratio over a large analog input frequency range (7.7 effective bits at 4.43 MHz full-scale input at  $f_{\text{clk}} = 75$  MHz)
- Overflow/underflow 3-state TTL output
- TTL compatible digital inputs
- Low-level AC clock input signal allowed
- External reference voltage regulator
- Power dissipation only 340 mW (typical)
- Low analog input capacitance, no buffer amplifier required
- No sample-and-hold circuit required.

## APPLICATIONS

High-speed analog-to-digital conversion for:

- video data digitizing
- radar pulse analysis
- transient signal analysis
- high energy physics research
- $\Sigma\Delta$  modulators
- medical imaging.

## GENERAL DESCRIPTION

The TDA8714 is an 8-bit high-speed analog-to-digital converter (ADC) for professional video and other applications. It converts the analog input signal into 8-bit binary-coded digital words at a maximum sampling rate of 75 MHz. All digital inputs and outputs are TTL compatible, although a low-level sine wave clock input signal is allowed.

## QUICK REFERENCE DATA

SYMBOL	PARAMETER	CONDITIONS	MIN.	TYP.	MAX.	UNIT
$V_{\text{CCA}}$	analog supply voltage		4.75	5.0	5.25	V
$V_{\text{CCD}}$	digital supply voltage		4.75	5.0	5.25	V
$V_{\text{CCO}}$	output stages supply voltage		4.75	5.0	5.25	V
$I_{\text{CCA}}$	analog supply current		–	25	27	mA
$I_{\text{CCD}}$	digital supply current		–	27	30	mA
$I_{\text{CCO}}$	output stages supply current		–	16	18	mA
ILE	DC integral linear error		–	$\pm 0.4$	$\pm 0.5$	LSB
DLE	DC differential linearity error		–	$\pm 0.2$	$\pm 0.35$	LSB
AILE	AC integral linearity error	note 1	–	$\pm 0.5$	$\pm 1.0$	LSB
$f_{\text{clk(max)}}$	maximum clock frequency					
	TDA8714/7		75	–	–	MHz
	TDA8714/6		60	–	–	MHz
	TDA8714/4		40	–	–	MHz
$P_{\text{tot}}$	total power dissipation		–	340	400	mW

## Note

1. Full-scale sine wave ( $f_i = 4.43$  MHz;  $f_{\text{clk}} = 75$  MHz).

8-bit high-speed analog-to-digital converter

TDA8714

ORDERING INFORMATION

TYPE NUMBER	PACKAGE				SAMPLING FREQUENCY
	PINS	PIN POSITION	MATERIAL	CODE	
TDA8714T/4	24	SO24L	plastic	SOT137-1	40 MHz
TDA8714M/4	24	SSOP24M	plastic	SOT340-1	40 MHz
TDA8714T/6	24	SO24L	plastic	SOT137-1	60 MHz
TDA8714M/6	24	SSOP24M	plastic	SOT340-1	60 MHz
TDA8714T/7	24	SO24L	plastic	SOT137-1	75 MHz
TDA8714M/7	24	SSOP24M	plastic	SOT340-1	75 MHz

BLOCK DIAGRAM

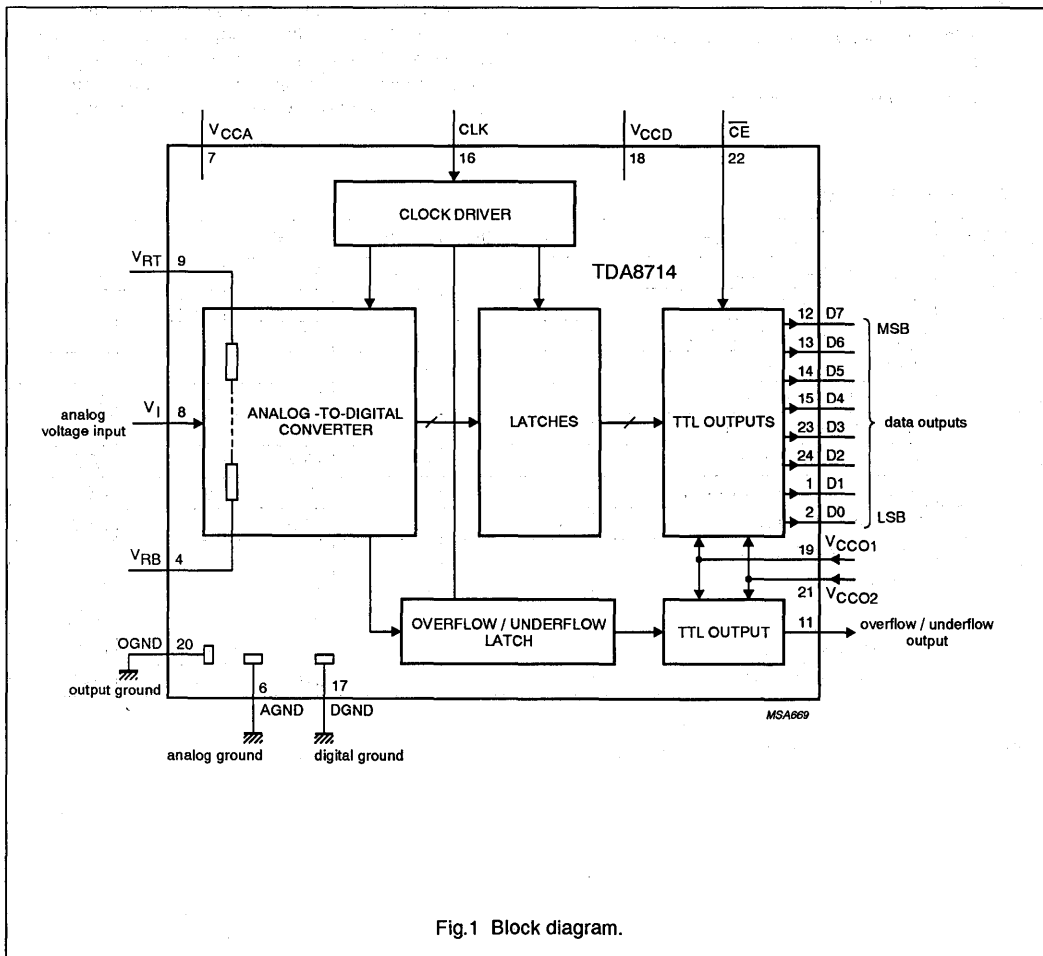

Fig.1 Block diagram.

## 8-bit high-speed analog-to-digital converter

TDA8714

## PINNING

SYMBOL	PIN	DESCRIPTION
D1	1	data output; bit 1
D0	2	data output; bit 0 (LSB)
n.c.	3	not connected
V <sub>RB</sub>	4	reference voltage BOTTOM input
n.c.	5	not connected
AGND	6	analog ground
V <sub>CCA</sub>	7	analog supply voltage (+5 V)
V <sub>I</sub>	8	analog input voltage
V <sub>RT</sub>	9	reference voltage TOP input
n.c.	10	not connected
O/UF	11	overflow/underflow data output
D7	12	data output; bit 7 (MSB)
D6	13	data output; bit 6
D5	14	data output; bit 5
D4	15	data output; bit 4
CLK	16	clock input
DGND	17	digital ground
V <sub>CCD</sub>	18	digital supply voltage (+5 V)
V <sub>CCO1</sub>	19	supply voltage for output stages 1 (+5 V)
OGND	20	output ground
V <sub>CCO2</sub>	21	supply voltage for output stages 2 (+5 V)
$\overline{\text{CE}}$	22	chip enable input (TTL level input, active LOW)
D3	23	data output; bit 3
D2	24	data output; bit 2

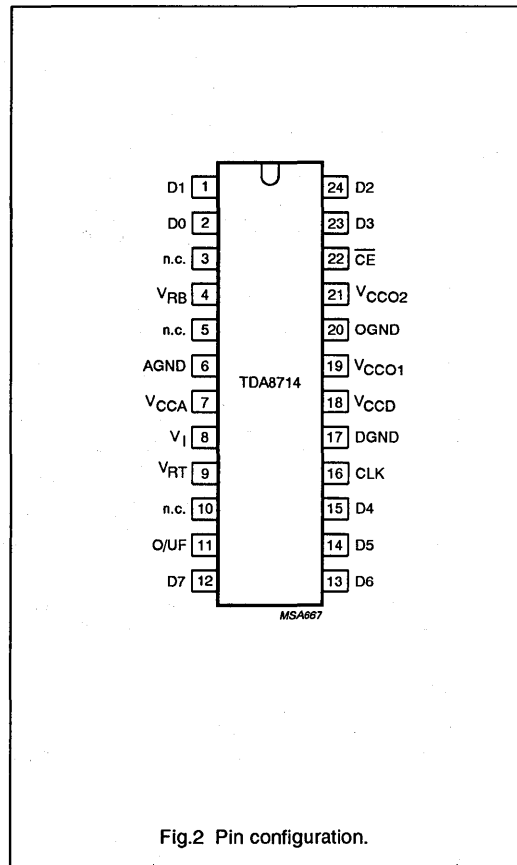

## 8-bit high-speed analog-to-digital converter

TDA8714

**LIMITING VALUES**

In accordance with the Absolute Maximum Rating System (IEC134).

SYMBOL	PARAMETER	CONDITIONS	MIN.	MAX.	UNIT
$V_{CCA}$	analog supply voltage	note 1	-0.3	+7.0	V
$V_{CCD}$	digital supply voltage	note 1	-0.3	+7.0	V
$V_{CCO}$	output stages supply voltage	note 1	-0.3	+7.0	V
$\Delta V_{CC}$	supply voltage differences between $V_{CCA}$ and $V_{CCD}$		-1.0	+1.0	V
$\Delta V_{CC}$	supply voltage differences between $V_{CCO}$ and $V_{CCD}$		-1.0	+1.0	V
$\Delta V_{CC}$	supply voltage differences between $V_{CCA}$ and $V_{CCO}$		-1.0	+1.0	V
$V_I$	input voltage	referenced to AGND	-0.3	+7.0	V
$V_{clk(p-p)}$	AC input voltage for switching (peak-to-peak value)	referenced to DGND	-	$V_{CCD}$	V
$I_O$	output current		-	10	mA
$T_{stg}$	storage temperature		-55	+150	°C
$T_{amb}$	operating ambient temperature		0	+70	°C
$T_j$	junction temperature		-	+150	°C

**Note**

1. The supply voltages  $V_{CCA}$  and  $V_{CCD}$  may have any value between -0.3 V and +7.0 V provided the difference between  $V_{CCA}$  and  $V_{CCD}$  is between -1 V and +1 V.

**HANDLING**

Inputs and outputs are protected against electrostatic discharges in normal handling. However, to be totally safe, it is desirable to take normal precautions appropriate to handling integrated circuits.

**THERMAL CHARACTERISTICS**

SYMBOL	PARAMETER	VALUE	UNIT
$R_{th\ j-a}$	thermal resistance from junction to ambient in free air		
	SOT137-1	75	K/W
	SOT340-1	119	K/W

## 8-bit high-speed analog-to-digital converter

TDA8714

## CHARACTERISTICS

$V_{CCA} = V_7$  to  $V_6 = 4.75$  to  $5.25$  V;  $V_{CCD} = V_{18}$  to  $V_{17} = 4.75$  to  $5.25$  V;  $V_{CCO} = V_{19}$  and  $V_{21}$  to  $V_{20} = 4.75$  to  $5.25$  V; AGND and DGND shorted together;  $V_{CCA}$  to  $V_{CCD} = -0.25$  to  $+0.25$  V;  $V_{CCO}$  to  $V_{CCD} = -0.25$  to  $+0.25$  V;

$V_{CCA}$  to  $V_{CCO} = -0.25$  to  $+0.25$  V;  $T_{amb} = 0$  to  $+70$  °C; typical values measured at  $V_{CCA} = V_{CCD} = V_{CCO} = 5$  V and  $T_{amb} = 25$  °C; unless otherwise specified.

SYMBOL	PARAMETER	CONDITIONS	MIN.	TYP.	MAX.	UNIT
<b>Supply</b>						
$V_{CCA}$	analog supply voltage		4.75	5.0	5.25	V
$V_{CCD}$	digital supply voltage		4.75	5.0	5.25	V
$V_{CCO}$	output stages supply voltage		4.75	5.0	5.25	V
$I_{CCA}$	analog supply current		–	25	27	mA
$I_{CCD}$	digital supply current		–	27	30	mA
$I_{CCO}$	output stages supply current		–	16	18	mA
<b>Inputs</b>						
CLOCK INPUT CLK (REFERENCED TO DGND); NOTE 1						
$V_{IL}$	LOW level input voltage		0	–	0.8	V
$V_{IH}$	HIGH level input voltage		2.0	–	$V_{CCD}$	V
$I_{IL}$	LOW level input current	$V_{clk} = 0.4$ V	–400	–	–	µA
$I_{IH}$	HIGH level input current	$V_{clk} = 2.7$ V	–	–	300	µA
$Z_I$	input impedance	$f_{clk} = 75$ MHz	–	2	–	kΩ
$C_I$	input capacitance	$f_{clk} = 75$ MHz	–	4.5	–	pF
INPUT $\overline{CE}$ (REFERENCED TO DGND) SEE TABLE 2						
$V_{IL}$	LOW level input voltage		0	–	0.8	V
$V_{IH}$	HIGH level input voltage		2.0	–	$V_{CCD}$	V
$I_{IL}$	LOW level input current	$V_{IL} = 0.4$ V	–400	–	–	µA
$I_{IH}$	HIGH level input current	$V_{IH} = 2.7$ V	–	–	20	µA
$V_I$ (ANALOG INPUT VOLTAGE REFERENCED TO AGND)						
$I_{IL}$	LOW level input current	$V_I = 1.2$ V	–	0	–	µA
$I_{IH}$	HIGH level input current	$V_I = 3.5$ V	60	130	180	µA
$Z_I$	input impedance	$f_i = 4.43$ MHz	–	10	–	kΩ
$C_I$	input capacitance	$f_i = 4.43$ MHz	–	14	–	pF
<b>Reference voltages for the resistor ladder; see Table 1</b>						
$V_{RB}$	reference voltage BOTTOM		1.2	1.3	1.6	V
$V_{RT}$	reference voltage TOP		3.5	3.6	3.9	V
$V_{diff}$	differential reference voltage $V_{RT} - V_{RB}$		1.9	2.3	2.7	V
$I_{ref}$	reference current		–	11.5	–	mA
$R_{LAD}$	resistor ladder		–	200	–	Ω
$TC_{RLAD}$	temperature coefficient of the resistor ladder		–	0.24	–	Ω/K
$V_{osB}$	offset voltage BOTTOM	note 2	–	255	–	mV
$V_{osT}$	offset voltage TOP	note 2	–	300	–	mV

## 8-bit high-speed analog-to-digital converter

TDA8714

SYMBOL	PARAMETER	CONDITIONS	MIN.	TYP.	MAX.	UNIT
<b>Outputs</b>						
DIGITAL OUTPUTS D7 TO D0 (REFERENCED TO DGND)						
$V_{OL}$	LOW level output voltage	$I_O = 1 \text{ mA}$	0	–	0.4	V
$V_{OH}$	HIGH level output voltage	$I_O = -0.4 \text{ mA}$	2.7	–	$V_{CCD}$	V
		$I_O = -1 \text{ mA}$	2.4	–	$V_{CCD}$	V
$I_{OZ}$	output current in 3-state mode	$0.4 \text{ V} < V_O < V_{CCD}$	–20	–	+20	$\mu\text{A}$
<b>Switching characteristics</b>						
CLOCK INPUT CLK (NOTE 1; SEE FIG.3)						
$f_{clk(max)}$	maximum clock frequency					
	TDA8714/4		40	–	–	MHz
	TDA8714/6		60	–	–	MHz
	TDA8714/7		75	–	–	MHz
$t_{CPH}$	clock pulse width HIGH		6	–	–	ns
$t_{CPL}$	clock pulse width LOW		6	–	–	ns
<b>Analog signal processing</b>						
LINEARITY						
ILE	DC integral linearity error		–	$\pm 0.4$	$\pm 0.5$	LSB
DLE	DC differential linearity error		–	$\pm 0.2$	$\pm 0.35$	LSB
AILE	AC integral linearity error	note 3	–	$\pm 0.5$	$\pm 1.0$	LSB
BANDWIDTH ( $f_{clk} = 40 \text{ MHz}$ )						
B	–0.5 dB analog bandwidth	full-scale sine wave	–	12	–	MHz
		75% full-scale sine wave	–	18	–	MHz
$t_{STLH}$	analog input settling time LOW-to-HIGH	full-scale square wave; Fig.12; note 4	–	2.5	3.5	ns
$t_{STHL}$	analog input settling time HIGH-to-LOW	full-scale square wave; Fig.12; note 4	–	3.0	4.0	ns
HARMONICS ( $f_{clk} = 40 \text{ MHz}$ )						
$n_1$	fundamental harmonics (full scale)	$f_i = 4.43 \text{ MHz}$	–	–	0	dB
$n_{all}$	harmonics (full scale); all components	$f_i = 4.43 \text{ MHz}$				
	second harmonics		–	–64	–60	dB
	third harmonics		–	–58	–55	dB
THD	total harmonic distortion	$f_i = 4.43 \text{ MHz}$	–	–56	–	dB
SIGNAL-TO-NOISE RATIO (NOTE 6; SEE FIG. 7 AND FIG. 13)						
S/N	signal-to-noise ratio (full scale)	without harmonics; $f_{clk} = 40 \text{ MHz};$ $f_i = 4.43 \text{ MHz}$	46	48	–	dB

## 8-bit high-speed analog-to-digital converter

TDA8714

SYMBOL	PARAMETER	CONDITIONS	MIN.	TYP.	MAX.	UNIT
<b>EFFECTIVE BITS (NOTE 6; SEE FIGS.7 AND 13)</b>						
EB	effective bits TDA8714/4	$f_{clk} = 40$ MHz $f_i = 4.43$ MHz $f_i = 7.5$ MHz	–	7.75	–	bits
	effective bits TDA8714/6	$f_{clk} = 60$ MHz $f_i = 4.43$ MHz $f_i = 7.5$ MHz $f_i = 10$ MHz	–	7.7	–	bits
	effective bits TDA8714/7	$f_{clk} = 75$ MHz $f_i = 4.43$ MHz $f_i = 7.5$ MHz $f_i = 10$ MHz $f_i = 15$ MHz	–	7.7	–	bits
			–	7.6	–	bits
			–	7.55	–	bits
			–	7.4	–	bits
			–	7.5	–	bits
			–	7.2	–	bits
			–	6.3	–	bits
<b>TWO-TONE (NOTE 7)</b>						
TTIR	two-tone intermodulation rejection	$f_{clk} = 40$ MHz	–	–56	–	dB
<b>BIT ERROR RATE</b>						
BER	bit error rate	$f_{clk} = 40$ MHz; $f_i = 4.43$ MHz; $V_I = \pm 16$ LSB at code 128	–	$10^{-11}$	–	times/ samples
<b>DIFFERENTIAL GAIN (NOTE 5)</b>						
$G_{diff}$	differential gain	$f_{clk} = 40$ MHz; $f_i = 4.43$ MHz	–	0.6	–	%
<b>DIFFERENTIAL PHASE (NOTE 5)</b>						
$\varphi_{diff}$	differential phase	$f_{clk} = 40$ MHz; $f_i = 4.43$ MHz	–	0.8	–	deg
<b>Timing (note 8; see Figs 3 and 5; <math>f_{clk} = 75</math> MHz)</b>						
$t_{ds}$	sampling delay time		–	–	2	ns
$t_h$	output hold time		5	–	–	ns
$t_d$	output delay time		–	10	11	ns
<b>3-state output delay times (see Fig.4)</b>						
$t_{dZH}$	enable HIGH		–	6	10	ns
$t_{dZL}$	enable LOW		–	12	16	ns
$t_{dHZ}$	disable HIGH		–	50	54	ns
$t_{dLZ}$	disable LOW		–	10	14	ns

---

**8-bit high-speed analog-to-digital converter****TDA8714**

---

**Notes to the "Characteristics"**

1. In addition to a good layout of the digital and analog ground, it is recommended that the rise and fall times of the clock must not be less than 1 ns.
2. Analog input voltages producing code 00 up to and including FF:
  - a)  $V_{osB}$  (voltage offset BOTTOM) is the difference between the analog input which produces data equal to 00 and the reference voltage BOTTOM ( $V_{RB}$ ) at  $T_{amb} = 25\text{ }^{\circ}\text{C}$ .
  - b)  $V_{osT}$  (voltage offset TOP) is the difference between  $V_{RT}$  (reference voltage TOP) and the analog input which produces data outputs equal to FF at  $T_{amb} = 25\text{ }^{\circ}\text{C}$ .
3. Full-scale sine wave ( $f_i = 4.43\text{ MHz}$ ;  $f_{clk} = 75\text{ MHz}$ ).
4. The analog input settling time is the minimum time required for the input signal to be stabilized after a sharp full-scale input (square-wave signal) in order to sample the signal and obtain correct output data.
5. Measurement carried out using video analyser VM700A.
6. Effective bits are obtained via a Fast Fourier Transform (FFT) treatment taking 8K acquisition points per period. The calculation takes into account all harmonics and noise up to half of the clock frequency (NYQUIST frequency). Conversion to signal-to-noise ratio:  $S/N = EB \times 6.02 + 1.76\text{ dB}$ .
7. Intermodulation measured relative to either tone with analog input frequencies of 4.43 MHz and 4.53 MHz. The two input signals have the same amplitude and the total amplitude of both signals provides full scale to the converter.
8. Output data acquisition: the output data is available after the maximum delay time of  $t_d$ ; in the event of 75 MHz clock operation, the hardware design must take into account the  $t_d$  and  $t_h$  limits with respect to the input characteristics of the acquisition circuit.



8-bit high-speed analog-to-digital converter

TDA8714

**Table 1** Output coding and input voltage (typical values; referenced to AGND).

STEP	$V_{I(p-p)}$	O/UF	BINARY OUTPUT BITS							
			D7	D6	D5	D4	D3	D2	D1	D0
Underflow	<1.555	1	0	0	0	0	0	0	0	0
0	1.555	0	0	0	0	0	0	0	0	0
1	.	0	0	0	0	0	0	0	0	1
.	.	.	.	.	.	.	.	.	.	.
.	.	.	.	.	.	.	.	.	.	.
254	.	0	1	1	1	1	1	1	1	0
255	3.30	0	1	1	1	1	1	1	1	1
Overflow	>3.30	1	1	1	1	1	1	1	1	1

**Table 2** Mode selection.

$\overline{CE}$	D7 TO D0	O/UF
1	high impedance	high impedance
0	active; binary	active

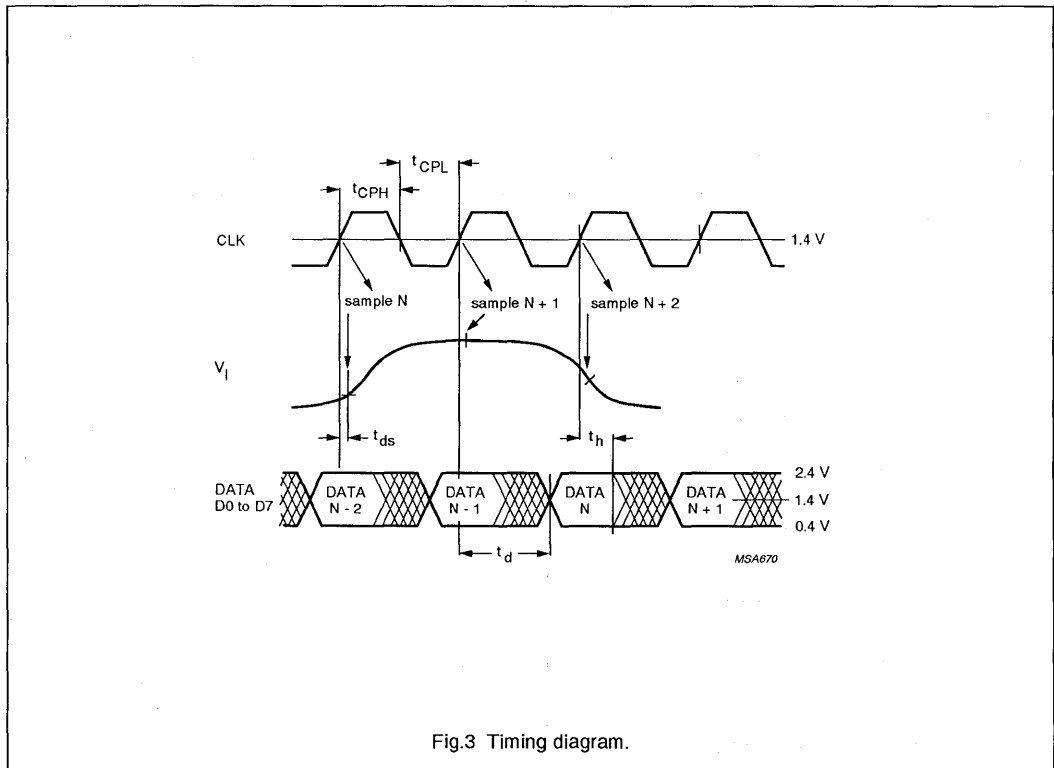

Fig.3 Timing diagram.

8-bit high-speed analog-to-digital converter

TDA8714

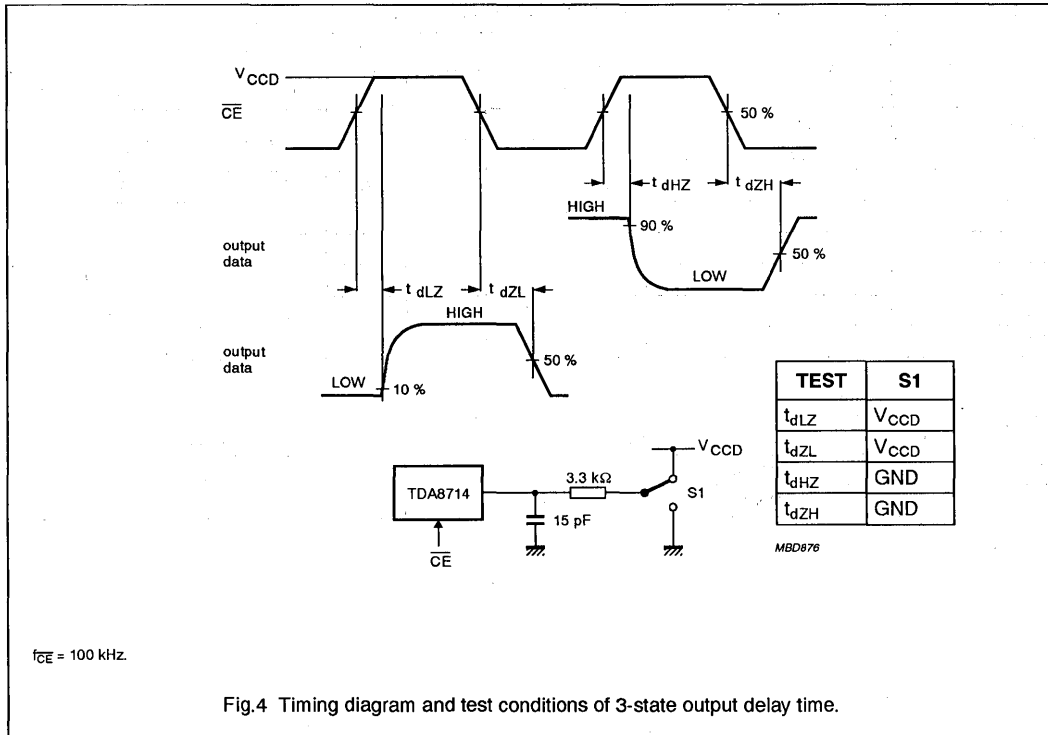

Fig.4 Timing diagram and test conditions of 3-state output delay time.

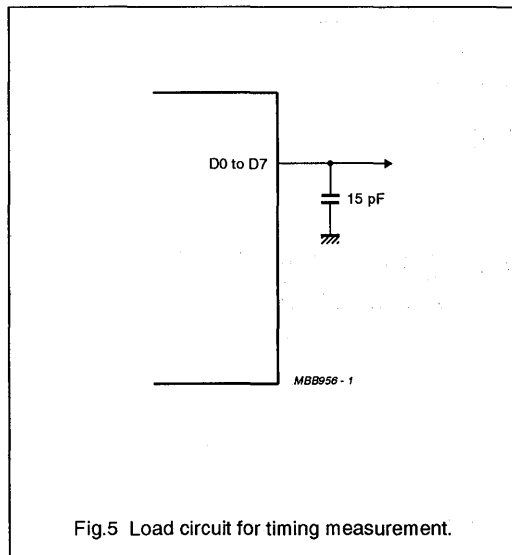

Fig.5 Load circuit for timing measurement.

8-bit high-speed analog-to-digital converter

TDA8714

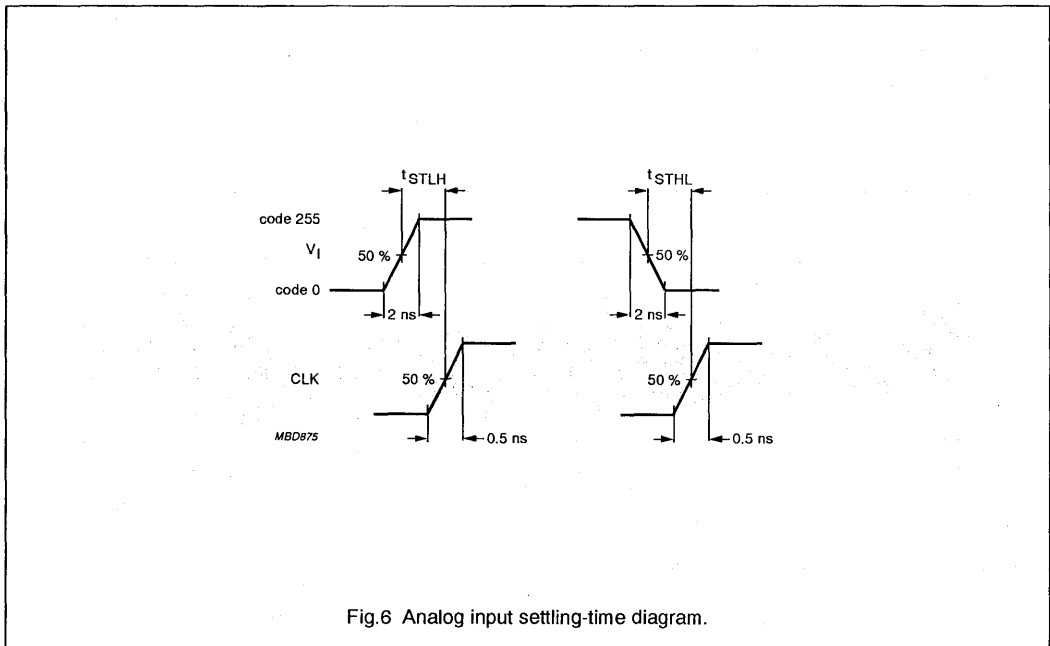

Fig.6 Analog input settling-time diagram.

8-bit high-speed analog-to-digital converter

TDA8714

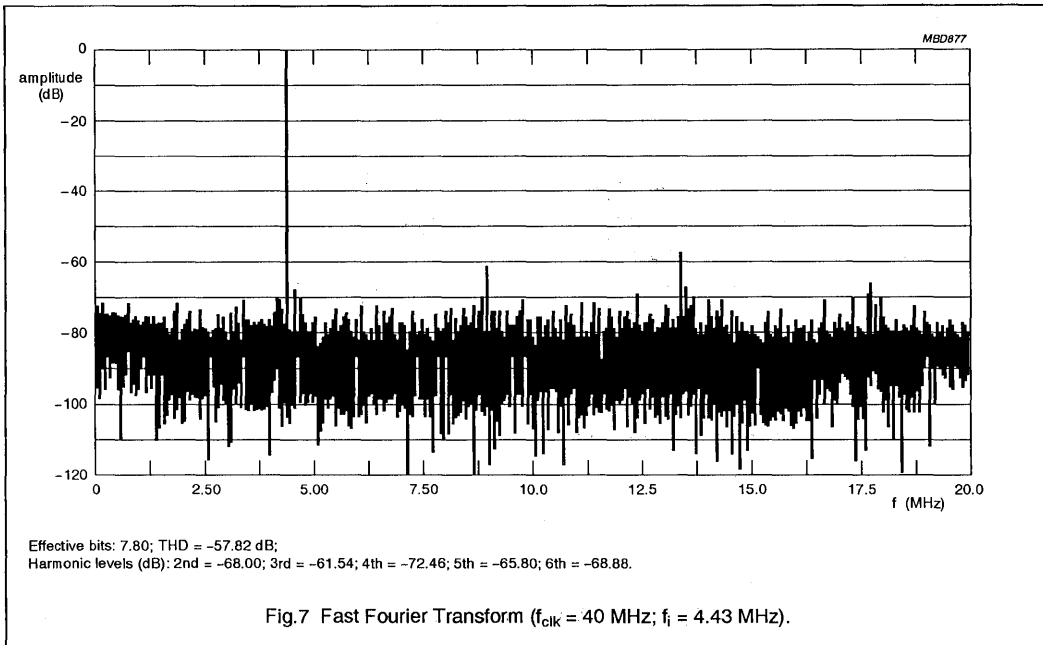

Fig.7 Fast Fourier Transform ( $f_{clk} = 40$  MHz;  $f_i = 4.43$  MHz).

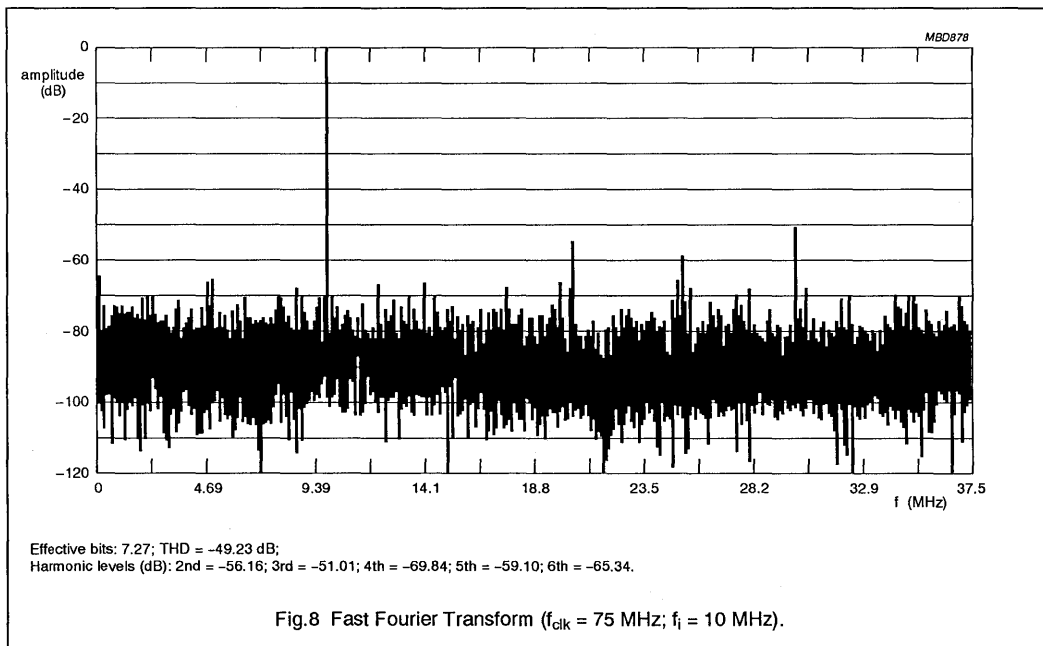

Fig.8 Fast Fourier Transform ( $f_{clk} = 75$  MHz;  $f_i = 10$  MHz).

8-bit high-speed analog-to-digital converter

TDA8714

INTERNAL PIN CONFIGURATIONS

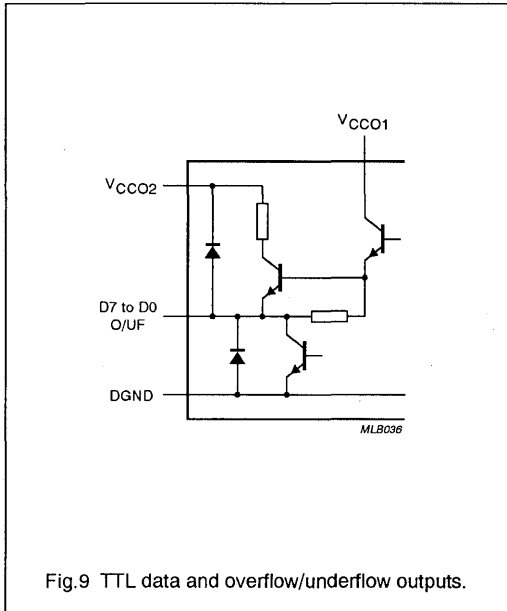

Fig.9 TTL data and overflow/underflow outputs.

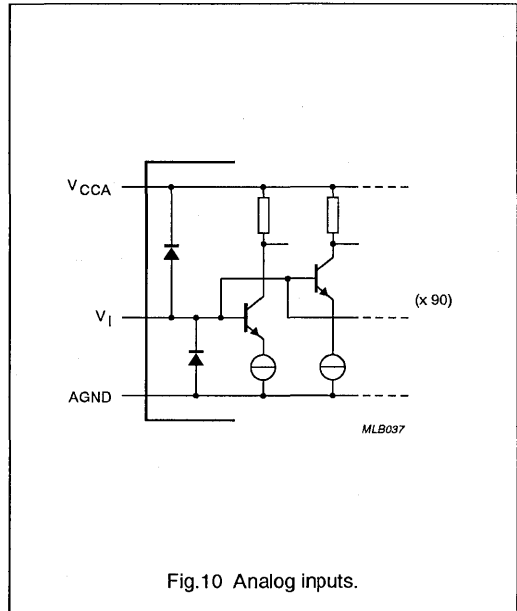

Fig.10 Analog inputs.

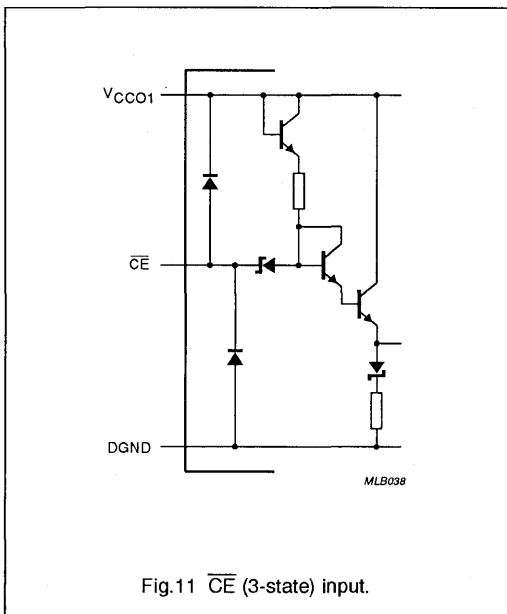

Fig.11  $\overline{CE}$  (3-state) input.

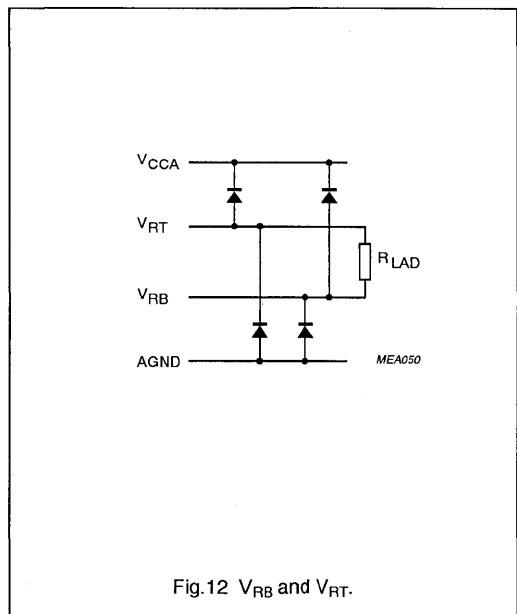

Fig.12  $V_{RB}$  and  $V_{RT}$ .

8-bit high-speed analog-to-digital converter

TDA8714

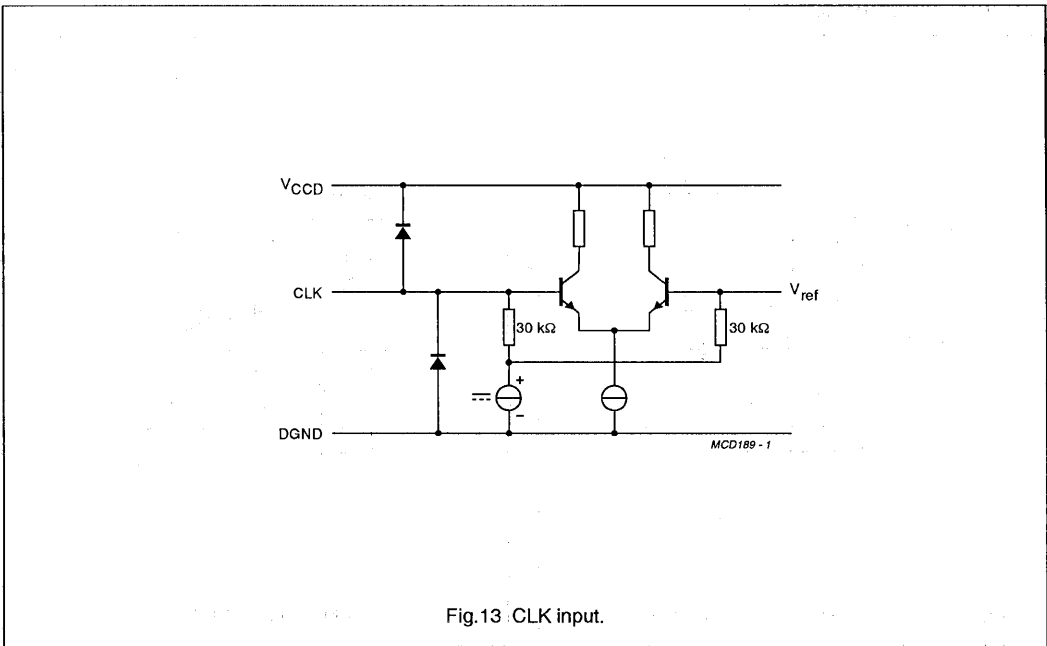

Fig.13 CLK input.

## 8-bit high-speed analog-to-digital converter

TDA8714

## APPLICATION INFORMATION

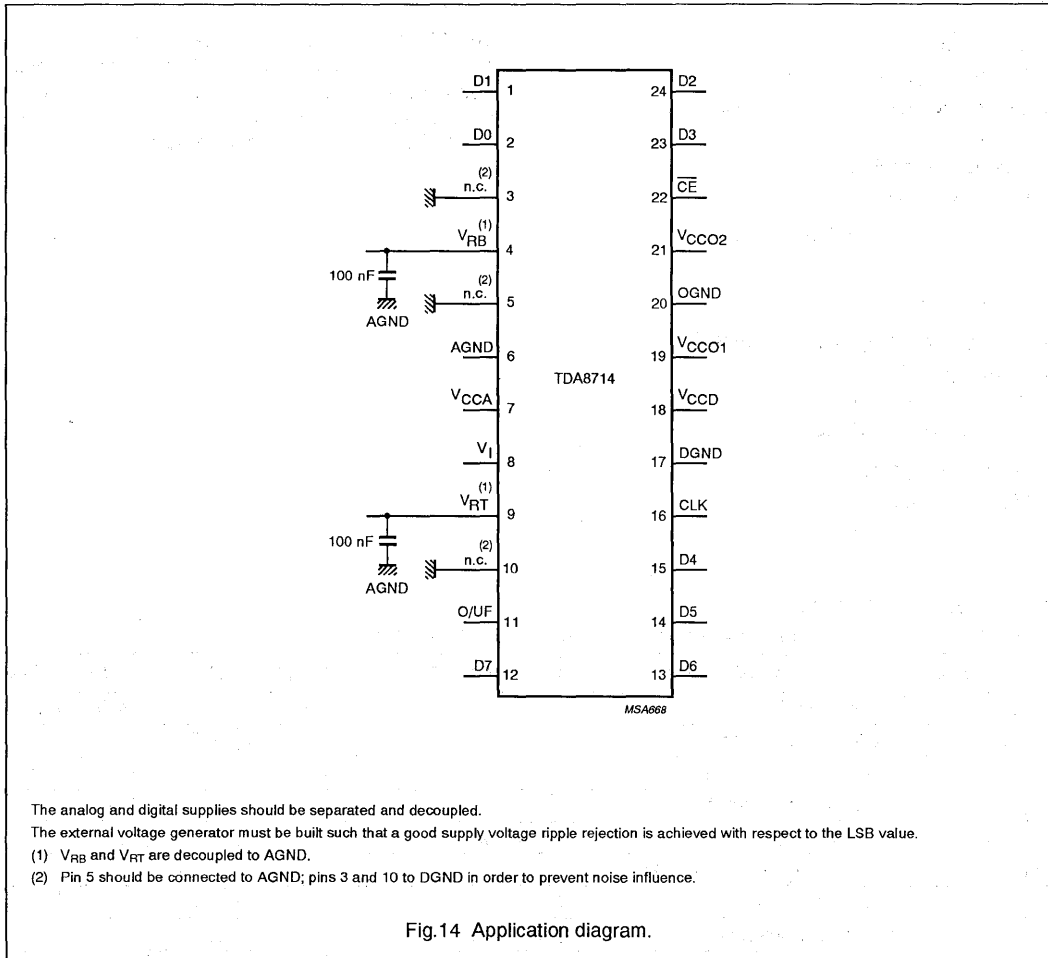

Fig.14 Application diagram.

# 8-bit high-speed analog-to-digital converter

## TDA8716

### FEATURES

- 8-bit resolution
- Sampling rate up to 120 MHz
- ECL (10 K family) compatible digital inputs and outputs
- Overflow/Underflow output
- Low power dissipation
- Low input capacitance (13 pF typ.).

### APPLICATIONS

- High speed analog-to-digital conversion
- Video signal digitizing
- Radar pulse analysis
- Transient signal analysis
- High energy physics research
- Medical systems
- Industrial instrumentation.

### GENERAL DESCRIPTION

The TDA8716 is an 8-bit high-speed analog-to-digital converter (ADC) designed for HDTV and professional applications. The device converts the analog input signal into 8-bit binary coded digital words at a sampling rate of 120 MHz. All digital outputs are ECL compatible.

### QUICK REFERENCE DATA

Measured over full voltage and temperature ranges, unless otherwise specified.

SYMBOL	PARAMETER	CONDITIONS	MIN.	TYP.	MAX.	UNIT
$V_{EEA}$	analog supply voltage		-5.45	-5.2	-4.95	V
$V_{EED}$	digital supply voltage		-5.45	-5.2	-4.95	V
$I_{EEA}$	analog supply current		-	50	55	mA
$I_{EED}$	digital supply current		-	100	110	mA
$I_{EEO}$	output supply current	$R_L = 2.2 \text{ k}\Omega$	-	20	25	mA
$V_{RB}$	reference voltage BOTTOM		-	-3.130	-	V
$V_{RT}$	reference voltage TOP		-	-1.870	-	V
ILE	DC integral linearity error	see Fig.8	-	$\pm 0.5$	$\pm 1$	LSB
DLE	DC differential linearity error	see Fig.9	-	$\pm 0.25$	$\pm 0.45$	LSB
EB	effective bit	$f_i = 20 \text{ MHz};$ $f_{CLK} = 100 \text{ MHz}$	-	7	-	bits
$f_{CLK}$	maximum clock frequency		120	-	-	MHz
$P_{tot}$	total power dissipation	excluding load	-	780	900	mW

### ORDERING INFORMATION

EXTENDED TYPE NUMBER	PACKAGE			
	PINS	PIN POSITION	MATERIAL	CODE
TDA8716	24	DIL	plastic	SOT101
TDA8716T	32	SO32L	plastic	SOT287



# 8-bit high-speed analog-to-digital converter

TDA8716

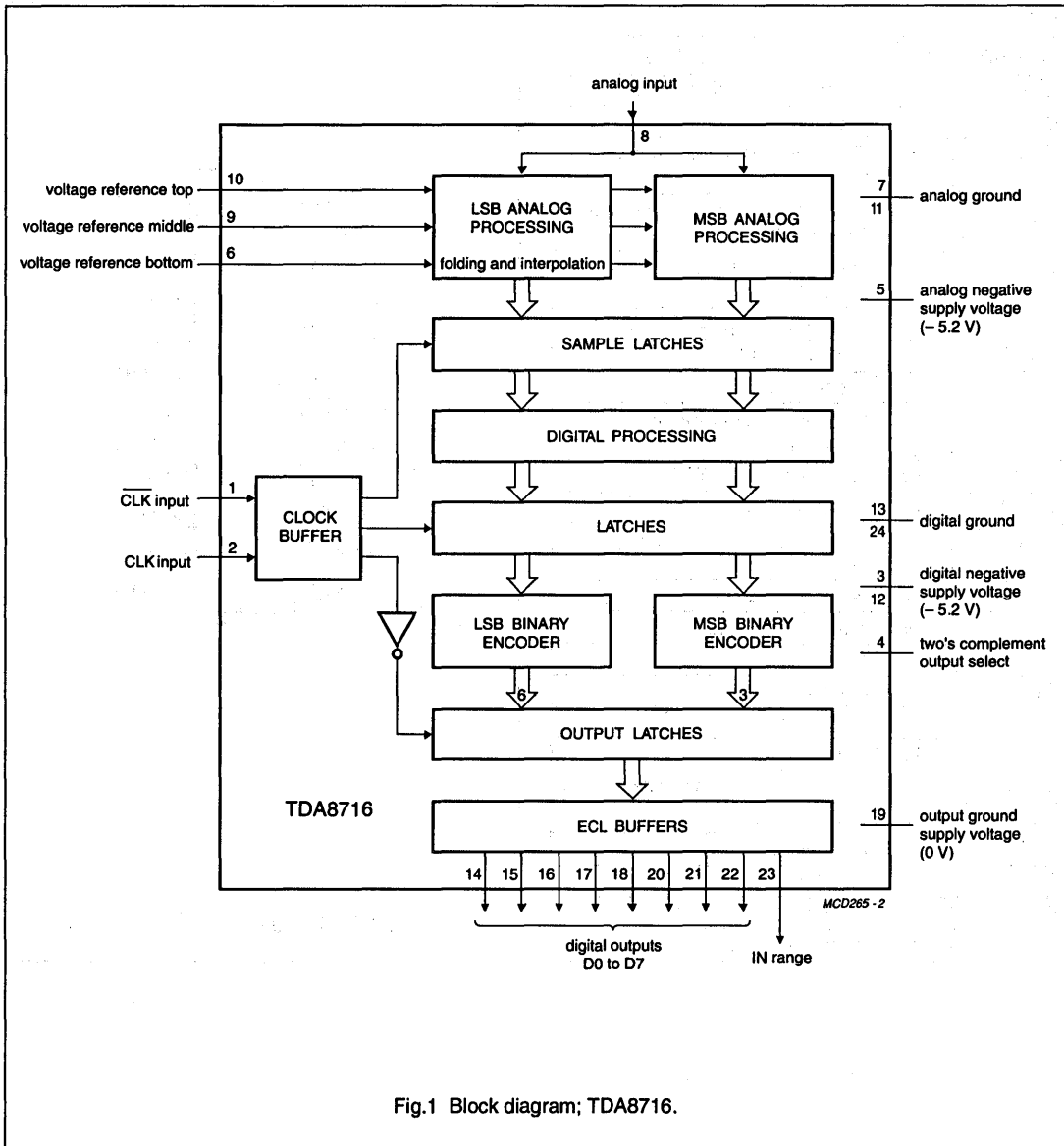

Fig.1 Block diagram; TDA8716.

# 8-bit high-speed analog-to-digital converter

TDA8716

**PINNING**

SYMBOL	PIN	DESCRIPTION
CLK	1	complementary clock input
CLK	2	clock input
V <sub>EED1</sub>	3	digital negative supply voltage (-5.2 V)
C <sub>PLT2</sub>	4	two's complement output select (active HIGH)
V <sub>EEA</sub>	5	analog negative supply voltage (-5.2 V)
V <sub>RB</sub>	6	reference voltage BOTTOM
AGND1	7	analog ground 1
V <sub>I</sub>	8	analog input
V <sub>RM</sub>	9	reference voltage MIDDLE decoupling
V <sub>RT</sub>	10	reference voltage TOP
AGND2	11	analog ground 2
V <sub>EED2</sub>	12	digital negative supply voltage (-5.2 V)
DGND1	13	digital ground 1
D0	14	digital output (LSB)
D1	15	digital output
D2	16	digital output
D3	17	digital output
D4	18	digital output
OGND	19	output ground supply voltage (0 V)
D5	20	digital output
D6	21	digital output
D7	22	digital output (MSB)
IR	23	IN range
DGND2	24	digital ground 2

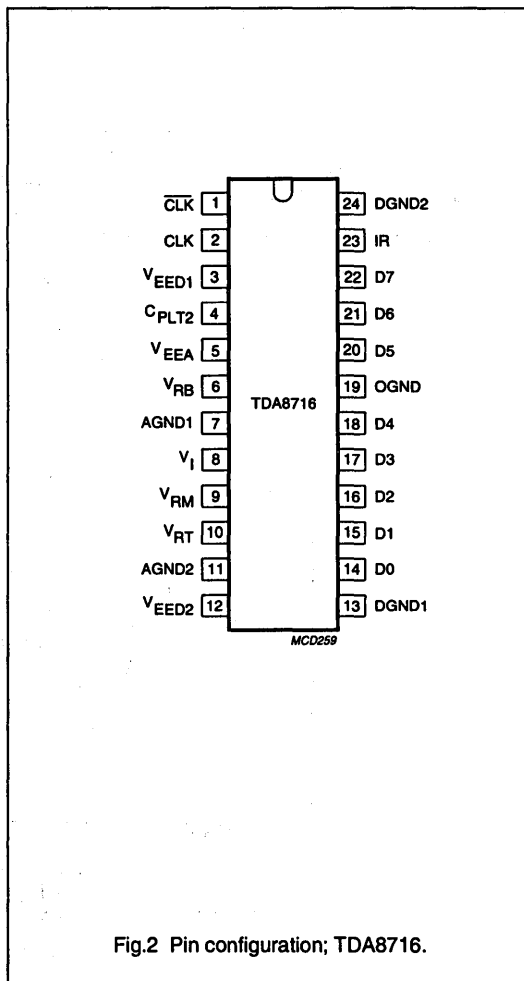

Fig.2 Pin configuration; TDA8716.

# 8-bit high-speed analog-to-digital converter

## TDA8716

### PINNING

SYMBOL	PIN	DESCRIPTION
$\overline{\text{CLK}}$	1	complementary clock input
CLK	2	clock input
$V_{\text{EED1}}$	3	digital negative supply voltage (-5.2 V)
n.c.	4	not connected
n.c.	5	not connected
$C_{\text{PLT2}}$	6	two's complement output select (active HIGH)
$V_{\text{EEA}}$	7	analog negative supply voltage (-5.2 V)
$V_{\text{RB}}$	8	reference voltage BOTTOM
AGND1	9	analog ground 1
$V_{\text{I}}$	10	analog input
$V_{\text{RM}}$	11	reference voltage MIDDLE decoupling
n.c.	12	not connected
n.c.	13	not connected
$V_{\text{RT}}$	14	reference voltage TOP
AGND2	15	analog ground 2
$V_{\text{EED2}}$	16	digital negative supply voltage (-5.2 V)
DGND1	17	digital ground 1
D0	18	digital output (LSB)
D1	19	digital output
n.c.	20	not connected
n.c.	21	not connected
D2	22	digital output
D3	23	digital output
D4	24	digital output
OGND	25	output ground supply voltage (0 V)
D5	26	digital output
D6	27	digital output
n.c.	28	not connected
n.c.	29	not connected
D7	30	digital output (MSB)
IR	31	IN range
DGND2	32	digital ground 2

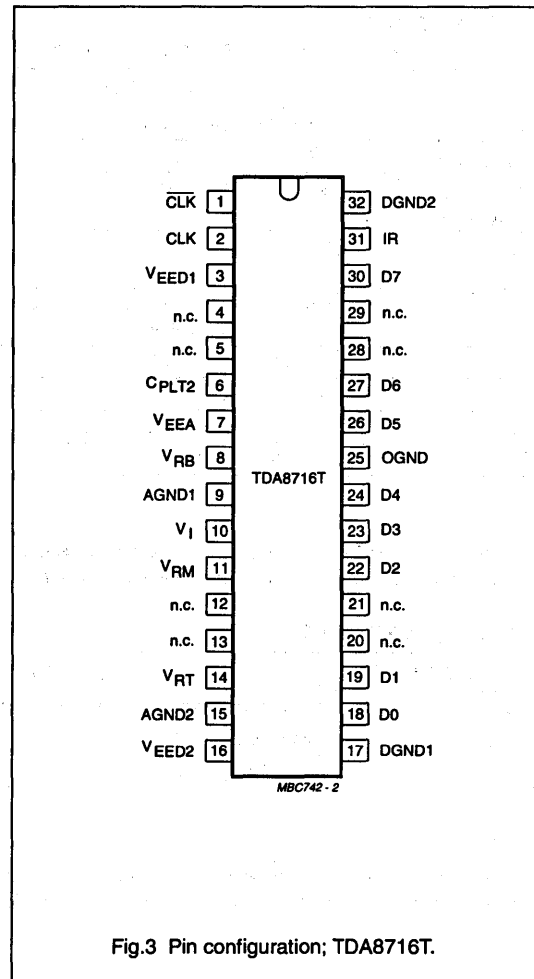

Fig.3 Pin configuration; TDA8716T.

# 8-bit high-speed analog-to-digital converter

TDA8716

## LIMITING VALUES

In accordance with the Absolute Maximum Rating System (IEC 134).

SYMBOL	PARAMETER	CONDITIONS	MIN.	MAX.	UNIT
$V_{EEA}$	analog supply voltage		-7.0	+0.3	V
$V_{EED1}, V_{EED2}$	digital supply voltage		-7.0	+0.3	V
$V_{EEA} - V_{EED1}$ , $V_{EEA} - V_{EED2}$	supply voltage differences		-1	+1	V
$V_i$	input voltage	referenced to AGND	$V_{EEA}$	0	V
$V_{CLK}, \overline{CLK}(p-p)$	input voltage for differential clock drive (peak-to-peak value)	note 1	-	2.0	V
$I_o$	output current (each output stage)		-	10	mA
$T_{stg}$	storage temperature		-55	+150	°C
$T_{amb}$	operating ambient temperature		0	+70	°C
$T_j$	junction temperature		-	+150	°C

### Note

- The circuit has two clock inputs: CLK and  $\overline{CLK}$ . Sampling takes place on the rising edge of the clock input signal: CLK and  $\overline{CLK}$  are two's complementary ECL signals.

## THERMAL RESISTANCE

SYMBOL	PARAMETER	THERMAL RESISTANCE
$R_{th\ j-a}$	from junction to ambient in free air	
	SOT101	35 K/W
	SOT287 (see Fig.4)	65 K/W

## HANDLING

Inputs and outputs are protected against electrostatic discharge in normal handling. However, to be totally safe, it is desirable to take normal precautions appropriate to handling integrated circuits.

# 8-bit high-speed analog-to-digital converter

TDA8716

## CHARACTERISTICS

$V_{EEA} = -4.95$  V to  $-5.45$  V;  $V_{EED1}, V_{EED2} = -4.95$  V to  $-5.45$  V; AGND, DGND and OGND shorted together;  
 $T_{amb} = 0$  °C to  $+70$ °C; unless otherwise specified. (Typical values taken at  $V_{EEA} = -5.2$  V;  $V_{EED1}, V_{EED2} = -5.2$  V;  
 $T_{amb} = 25$  °C).

SYMBOL	PARAMETER	CONDITIONS	MIN.	TYP.	MAX.	UNIT
<b>Supply</b>						
$V_{EEA}$	analog supply voltage		-5.45	-5.2	-4.95	V
$V_{EED1}, V_{EED2}$	digital supply voltage		-5.45	-5.2	-4.95	V
$I_{EEA}$	analog supply current		-	50	55	mA
$I_{EED1}, I_{EED2}$	digital supply current		-	100	110	mA
$I_{EE}$	output supply current	$R_L = 2.2$ k $\Omega$	-	20	25	mA
$V_{diff}$	supply voltage differential	$V_{EEA} - V_{EED1}, V_{EEA} - V_{EED2}$	-0.5	0	+0.5	V
<b>Reference voltages for the resistor ladder</b>						
$V_{RB}$	reference voltage BOTTOM		-3.5	-3.13	-	V
$V_{RT}$	reference voltage TOP		-	-1.87	-1.5	V
$V_{ref}$	reference voltage differential	$V_{RT} - V_{RB}$	-	1.26	-	V
$V_{OB}$	voltage offset BOTTOM	note 1	-	130	-	mV
$V_{OT}$	voltage offset TOP	note 1	-	130	-	mV
$V_{(p-p)}$	input voltage amplitude (peak-to-peak value)		0.95	1.0	1.5	V
$I_{ref}$	reference current		-	15	-	mA
$R_{LAD}$	resistor ladder		-	85	-	$\Omega$
$TC_{RL}$	temperature coefficient of the resistor ladder		-	0.18	-	$\Omega/K$
<b>Inputs</b>						
<b>CLK and <math>\overline{CLK}</math> input</b>						
$V_{IL}$	LOW level input voltage		-1850	-1770	-1650	mV
$V_{IH}$	HIGH level input voltage		-960	-880	-810	mV
$I_{IL}$	LOW level input current	$V_{CLK} = -1.77$ V	-	1	-	$\mu$ A
$I_{IH}$	HIGH level input current	$V_{CLK} = -0.88$ V	-	10	-	$\mu$ A
$R_i$	input resistance		-	20	-	k $\Omega$
$C_i$	input capacitance		-	2	-	pF
$V_{CLK(p-p)}$	differential clock input $V_{CLK} - \overline{V_{CLK}}$ (peak-to-peak value)		-	900	-	mV
<b>Analog input; note 2</b>						
$I_B$	input current BOTTOM	$V_{RB} = -3.13$ V	-	0	-	$\mu$ A
$I_T$	input current TOP	$V_{RT} = -1.87$ V	-	170	-	$\mu$ A
$R_i$	input resistance		-	7	-	k $\Omega$
$C_i$	input capacitance		-	13	20	pF

# 8-bit high-speed analog-to-digital converter

TDA8716

SYMBOL	PARAMETER	CONDITIONS	MIN.	TYP.	MAX.	UNIT
<b>Outputs (<math>R_L = 2.2 \text{ k}\Omega</math>)</b>						
<b>Digital 10K ECL outputs (D0 to D7; IR)</b>						
$V_{OL}$	LOW level output voltage		-1850	-1770	-1600	mV
$V_{OH}$	HIGH level output voltage		-960	-880	-810	mV
$I_{OL}$	LOW level output current		-	1.8	4.0	mA
$I_{OH}$	HIGH level output current		-	2.0	4.0	mA
<b>Timing (<math>f_{CLK} = 100 \text{ MHz}</math>; <math>R_L = 2.2 \text{ k}\Omega</math>; see Fig.5)</b>						
$t_{ds}$	sampling delay		-	1	3	ns
$t_{HD}$	output hold time		4	-	-	ns
$t_d$	output delay time	note 3 $C_L = 3.3 \text{ pF}$ $C_L = 7.5 \text{ pF}$	-	-	7.5	ns
			-	-	9	ns
$t_{aj}$	aperture jitter		-	15	-	ps
<b>Switching characteristics</b>						
$f_{CLK}; \overline{f_{CLK}}$	maximum clock frequency		120	-	-	MHz
<b>Analog signal processing (<math>f_{CLK} = 100 \text{ MHz}</math>)</b>						
$G_{diff}$	differential gain	note 4	-	0.3	-	%
$\Phi_{diff}$	differential phase	note 4	-	0.4	-	$^\circ\text{C}$
<b>Harmonics (full scale); <math>f_i = 10 \text{ MHz}</math>; <math>f_{CLK} = 100 \text{ MHz}</math></b>						
f1	fundamental		-	0	-	dB
f2	even harmonics		-	-60	-	dB
f3	odd harmonics		-	-50	-	dB
<b>Transfer function</b>						
ILE	DC integral linearity error		-	$\pm 0.5$	$\pm 1$	LSB
DLE	DC differential linearity error		-	$\pm 0.25$	$\pm 0.45$	LSB
AILE	AC integral linearity error	note 4	-	$\pm 1$	$\pm 1.5$	LSB
EB	effective bits	Figs 13 and 14; note 5; $f_{CLK} = 100 \text{ MHz}$				
	$f_i = 4.43 \text{ MHz}$	Fig.10	-	7.7	-	bits
	$f_i = 10 \text{ MHz}$	Fig.11	-	7.5	-	bits
	$f_i = 20 \text{ MHz}$	Fig.12	-	7.0	-	bits
	$f_i = 30 \text{ MHz}$		-	6.5	-	bits
BER	bit error rate	$f_{CLK} = 100 \text{ MHz}$ ; $f_i = 10 \text{ MHz}$ ; $V_i = \pm 8 \text{ LSB}$ at code 128; 50% clock duty cycle	-	$10^{-11}$	-	times/ samples

# 8-bit high-speed analog-to-digital converter

TDA8716

## Notes

1. Voltage offset BOTTOM ( $V_{OB}$ ) is the difference between the analog input which produces data outputs equal to 00 and the reference voltage BOTTOM ( $V_{RB}$ ), at  $T_{amb} = 25^\circ\text{C}$ . Voltage offset TOP ( $V_{OT}$ ) is the difference between reference voltage TOP ( $V_{RT}$ ) and the analog input which produces data outputs equal to FF, at  $T_{amb} = 25^\circ\text{C}$ .
2. The analog input is not internally biased. It should be externally biased between  $V_{RB}$  and  $V_{RT}$  levels.
3. The TDA8716 can only withstand one or two 10K or 100K ECL loads in order to work-out timings at the maximum sampling frequency. It is therefore recommended to minimize the printed-circuit board load by implementing the load device as close as possible to the TDA8716.
4. Full-scale sinewave;  $f_i = 4.43\text{ MHz}$ ;  $f_{CLK}$ ,  $f_{CLK}^{-1} = 100\text{ MHz}$ .
5. Effective bits are obtained via a Fast Fourier Transformer (FFT) treatment taking 4 K acquisition points per period. The calculation takes into account all harmonics and noise up to half of the clock frequency (NYQUIST frequency). Conversion to SNR:  $\text{SNR} = \text{EB (dB)} \times 6.02 + 1.76$ .

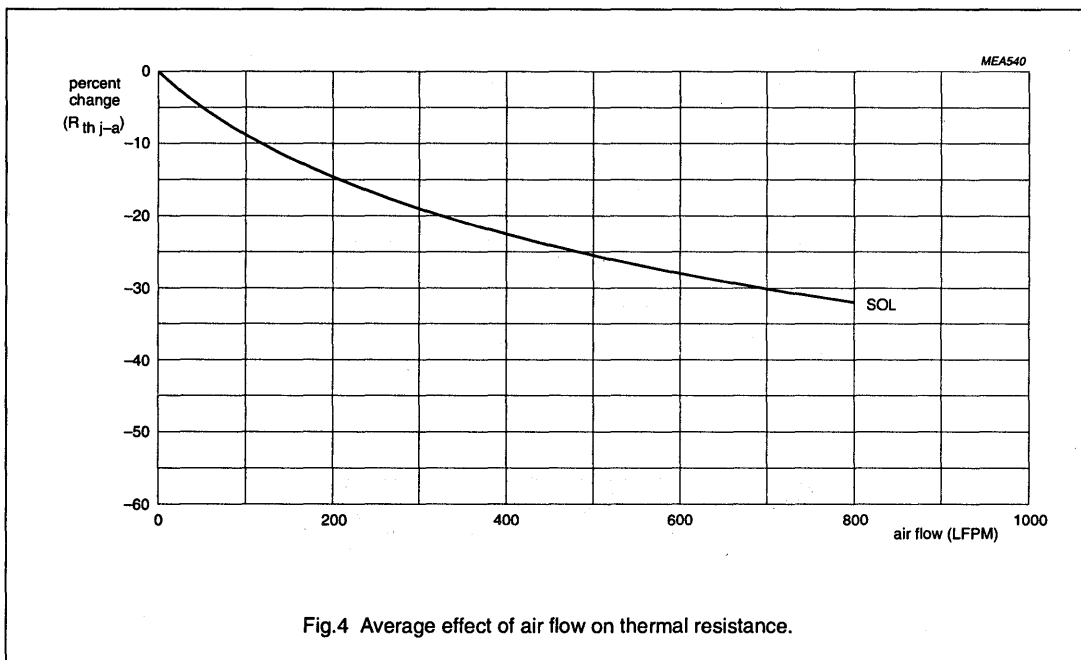

Fig.4 Average effect of air flow on thermal resistance.

# 8-bit high-speed analog-to-digital converter

TDA8716

**Table 1** Output coding (CPLT2 HIGH).

STEP	$V_i$ (TYP.)	BINARY OUTPUTS D7 to D0	IR
Underflow	$< -3$ V	00000000	0
0	$-3$ V	00000000	1
1	.	00000001	1
.	.	.....	.
.	.	.....	.
.	.	.....	.
254	.	11111110	1
255	$-2$ V	11111111	1
Overflow	$> -2$ V	11111111	0

**Table 2** Two's complement coding.

$C_{PLT2}$	D7 (MSB)
1 ( $V_{IH}$ )	non inverted
0 ( $V_{IL}$ )	inverted

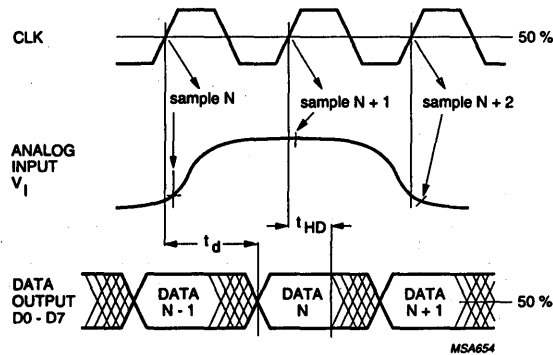

**Fig.5** Timing diagram.



# 8-bit high-speed analog-to-digital converter

TDA8716

## APPLICATION INFORMATION

Additional application information will be supplied upon request, please quote reference number FTV/AN 9109.

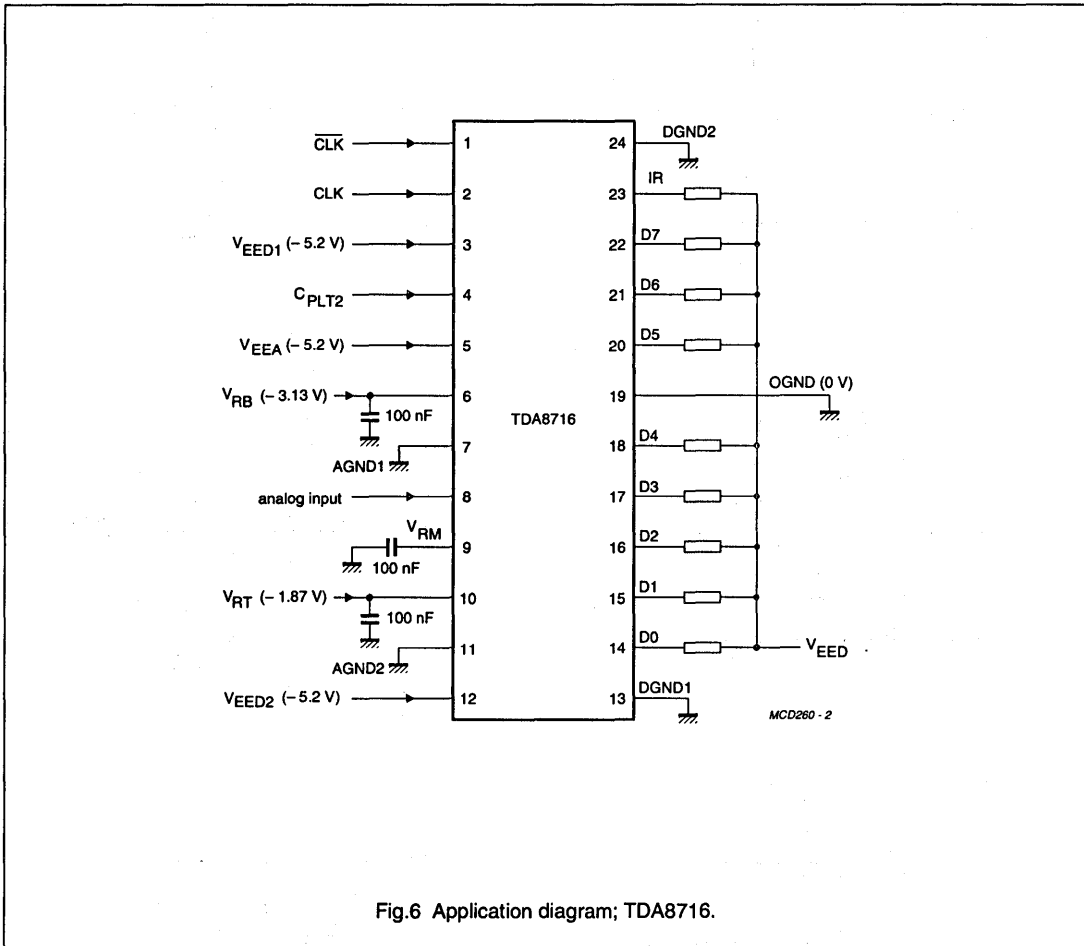

Fig.6 Application diagram; TDA8716.

### Notes to Fig.6

1. Typical value for resistors = 2.2 k $\Omega$ .
2. Lower resistor values can be used down to 500  $\Omega$  to obtain higher sampling frequencies in the 150 MSPS range (limited by  $t_J$  and  $t_{HD}$  timings). In this configuration a DC shift of the ECL output levels  $V_{OL}$  and  $V_{OH}$  will occur.
3.  $V_{RB}$ ,  $V_{RT}$  and  $V_M$  are decoupled to AGND.
4. Analog, digital and output supplies should be separated and decoupled.
5. The external voltage regulator must be constructed in such a way that a good supply voltage ripple rejection is achieved with respect to the LSB value.

# 8-bit high-speed analog-to-digital converter

TDA8716

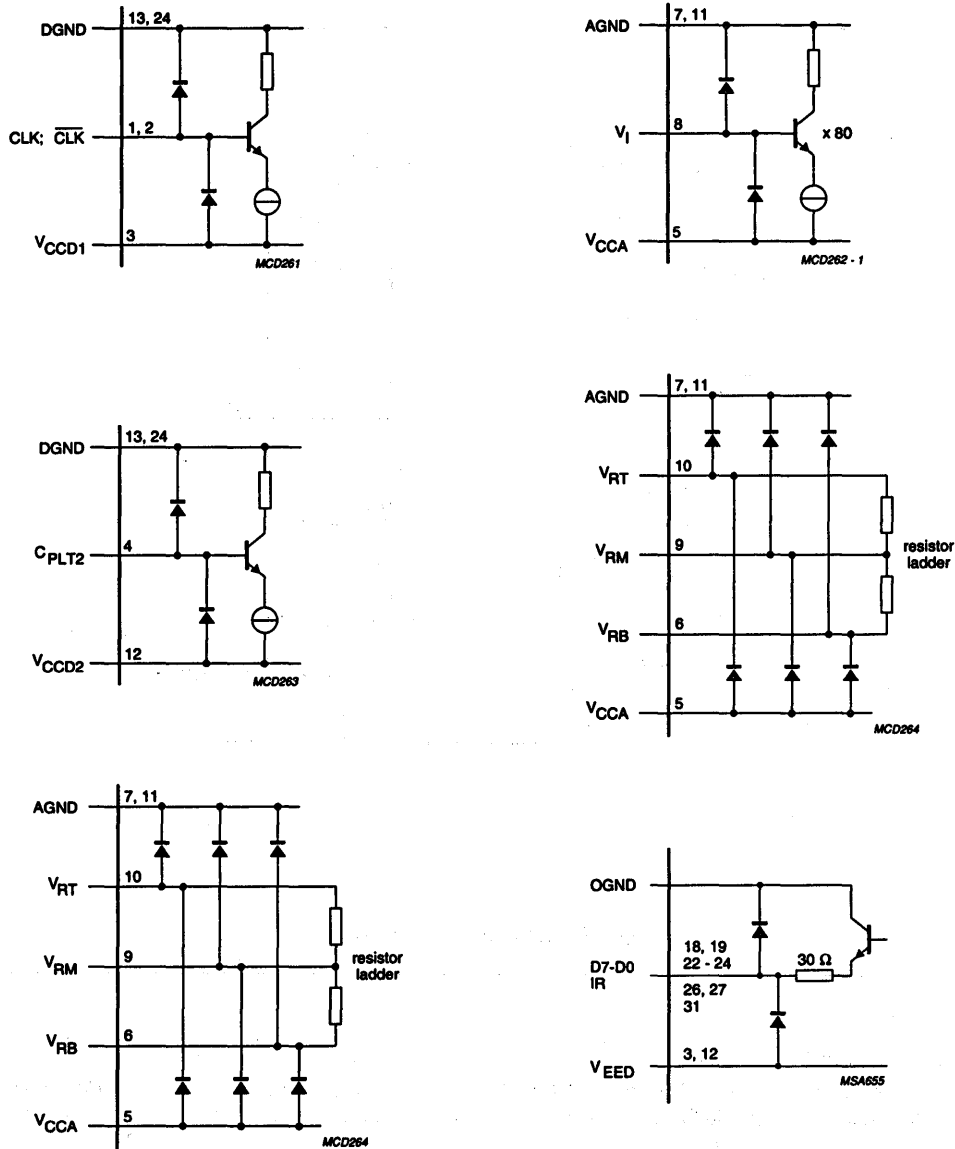

Fig.7 Internal pin configuration diagram.

# 8-bit high-speed analog-to-digital converter

TDA8716

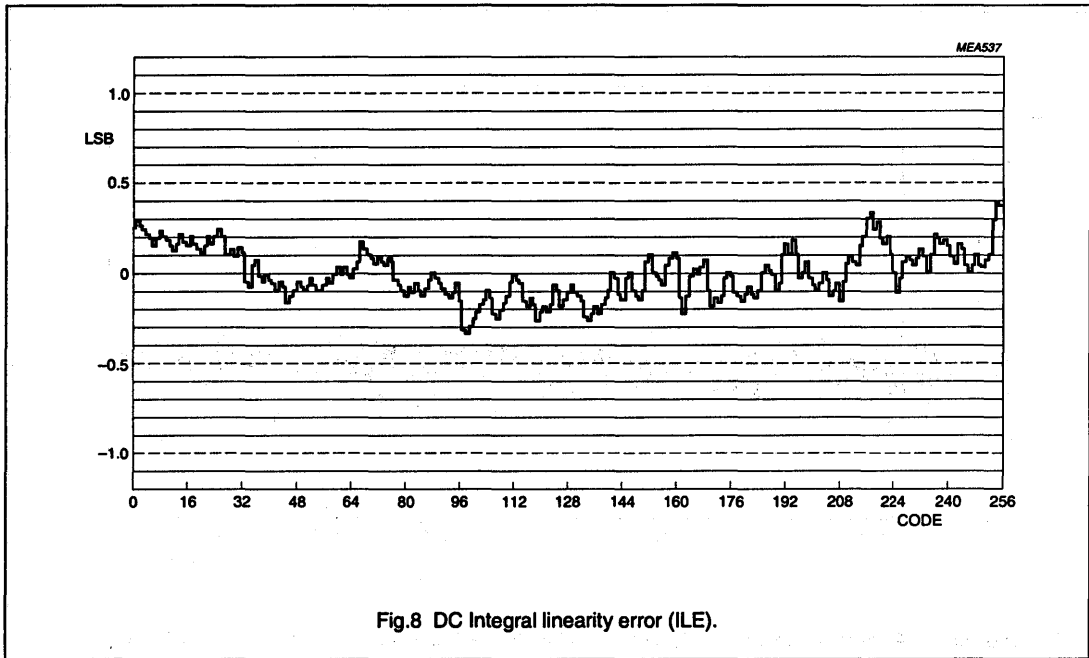

Fig.8 DC Integral linearity error (ILE).

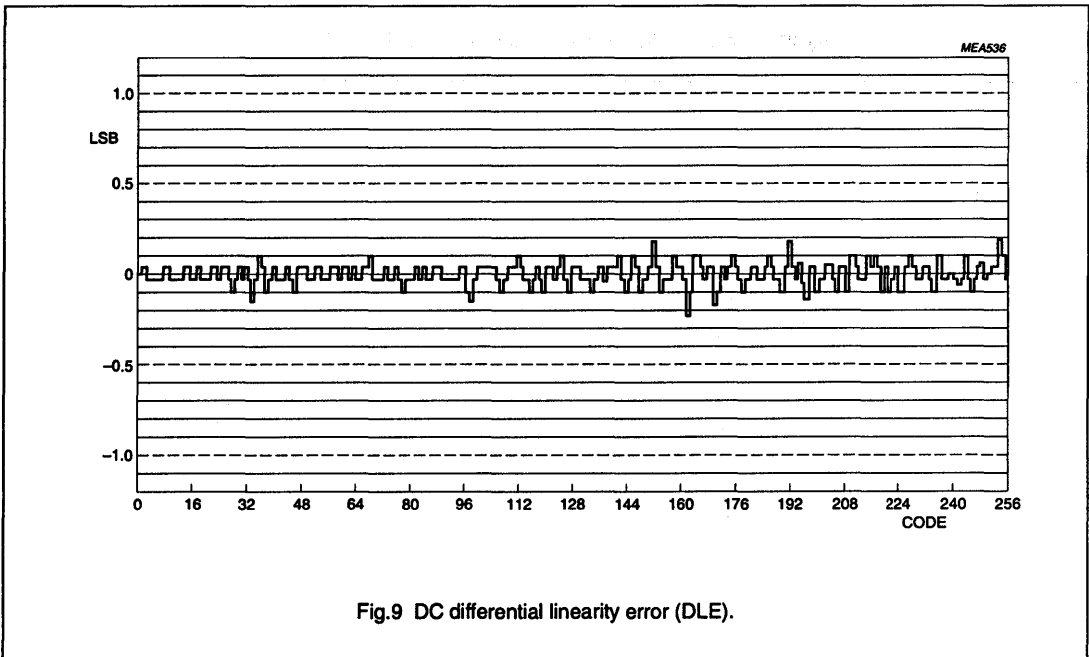
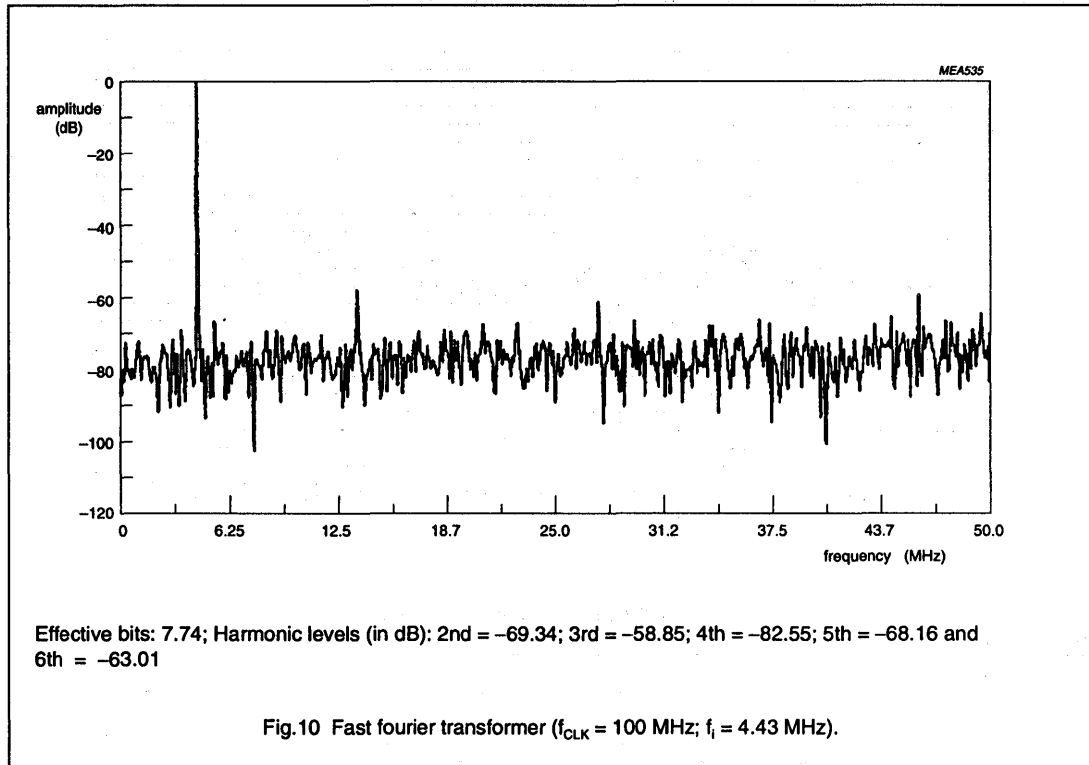
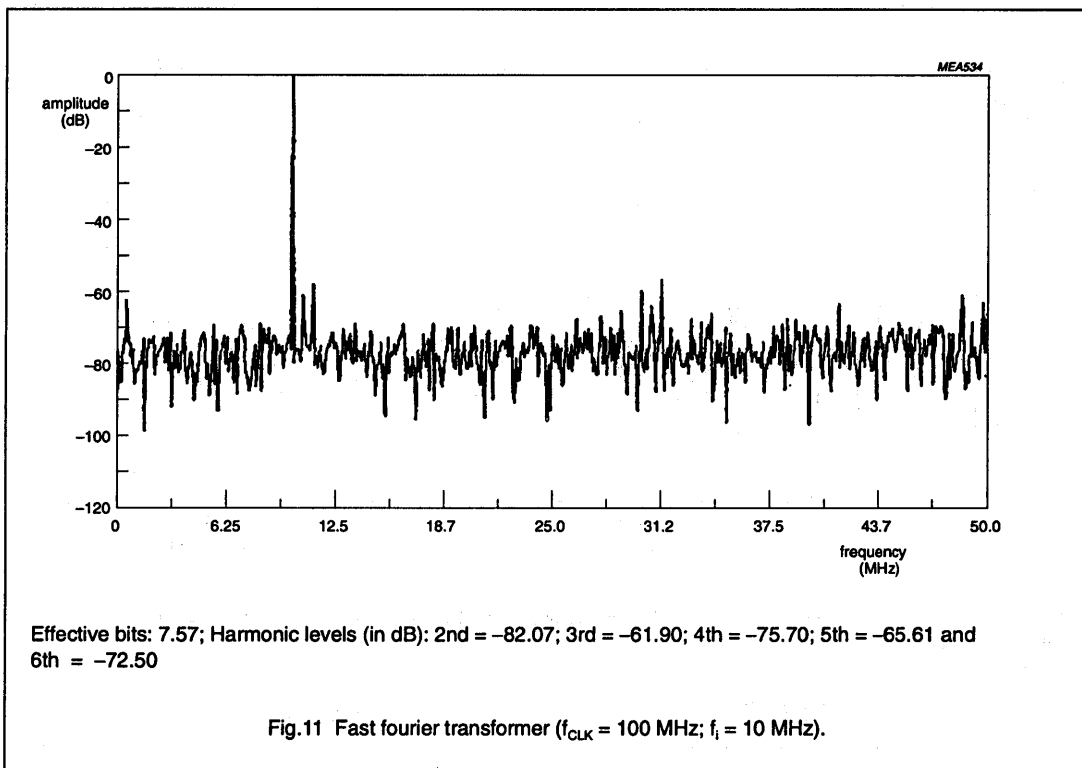

Fig.9 DC differential linearity error (DLE).

**8-bit high-speed analog-to-digital  
converter****TDA8716**

8-bit high-speed analog-to-digital  
converter

TDA8716



8-bit high-speed analog-to-digital converter

TDA8716

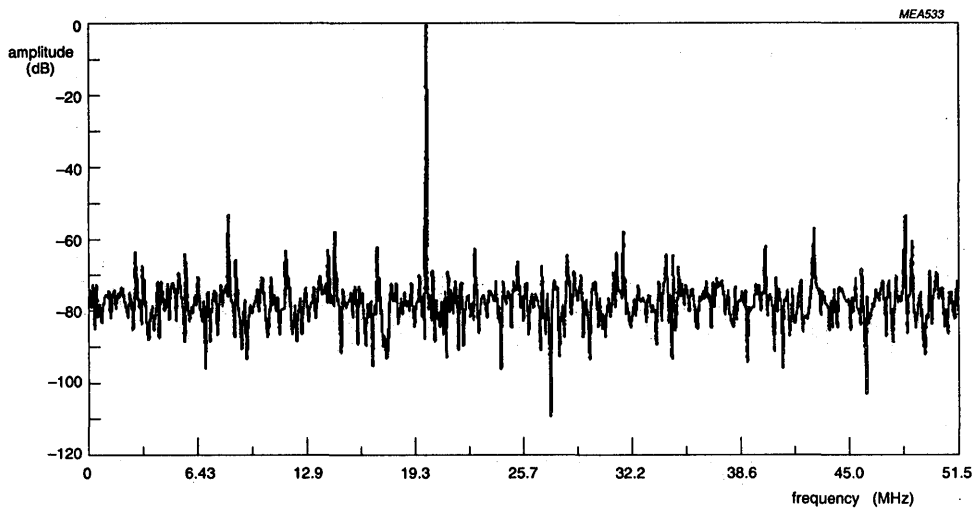

Effective bits: 7.04; Harmonic levels (in dB): 2nd = -61.36; 3rd = -56.66; 4th = -61.97; 5th = -62.79 and 6th = -61.52

Fig.12 Fast fourier transformer ( $f_{CLK} = 100$  MHz;  $f_i = 20$  MHz).

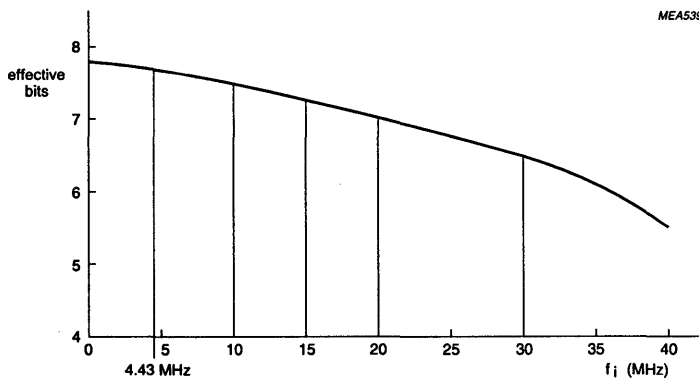
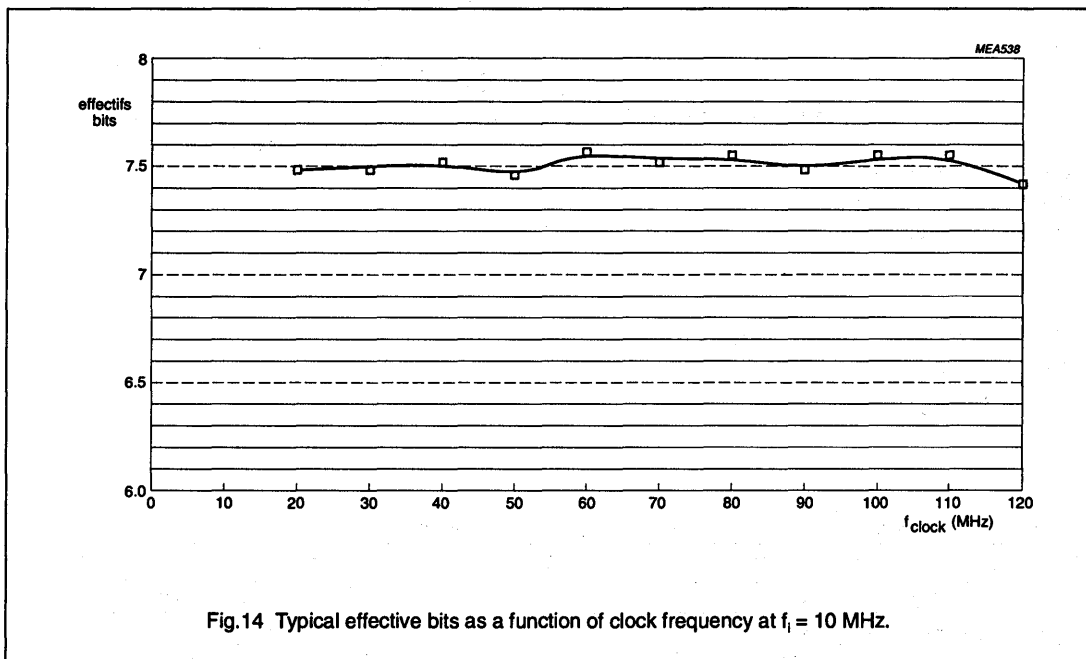

Fig.13 Typical effective bit as a function of input signal at  $f_{CLK} = 100$  MHz.

8-bit high-speed analog-to-digital converter

TDA8716



## 8-bit high-speed analog-to-digital converter

TDA8718

## FEATURES

- 8-bit resolution
- Sampling rate up to 600 MHz
- ECL (100K family) compatible for digital inputs and outputs
- Overflow/Underflow output
- 50  $\Omega$  load drive capability
- Low input capacitance (5 pF typ.).

## APPLICATIONS

- High speed analog-to-digital conversion
- Industrial instrumentation
- Data communication
- RF communication.

## QUICK REFERENCE DATA

Measured over full voltage and temperature ranges, unless otherwise specified.

SYMBOL	PARAMETER	CONDITIONS	MIN.	TYP.	MAX.	UNIT
$V_{EEA}$	analog supply voltage		-4.2	-4.5	-4.8	V
$V_{EED}$	digital supply voltage		-4.2	-4.5	-4.8	V
$I_{ref}$	resistive ladder current	$R_L = 48 \Omega$	30	45	60	mA
$I_{EEA}$	analog supply current		30	42	54	mA
$I_{EED}$	digital supply current		100	120	150	mA
$I_{EEO(L)}$	LOW level output supply current	$R_L = 50 \Omega$	40	70	90	mA
$I_{EEO(H)}$	HIGH level output supply current	$R_L = 50 \Omega$	155	170	185	mA
ILE	DC integral linearity error		-	$\pm 0.7$	$\pm 1.0$	LSB
DLE	DC differential linearity error		-	$\pm 0.3$	$\pm 0.5$	LSB
EB	effective bits	$f_i = 4.43 \text{ MHz}; I_{ref} = 45 \text{ mA};$ $f_{clk} = 100 \text{ MHz}$	-	7.5	-	bits
		$f_i = 4.43 \text{ MHz}; I_{ref} = 45 \text{ mA};$ $f_{clk} = 100 \text{ MHz}$	-	6.5	-	bits
$f_{clk(max)}$	maximum clock frequency		600	-	-	MHz
$P_{tot}$	total power dissipation		-	990	1250	mW

## ORDERING INFORMATION

TYPE NUMBER	PACKAGE			
	PINS	PIN POSITION	MATERIAL	CODE
TDA8718K	28	PLCC28	plastic	SOT261-2



8-bit high-speed analog-to-digital converter

TDA8718

BLOCK DIAGRAM

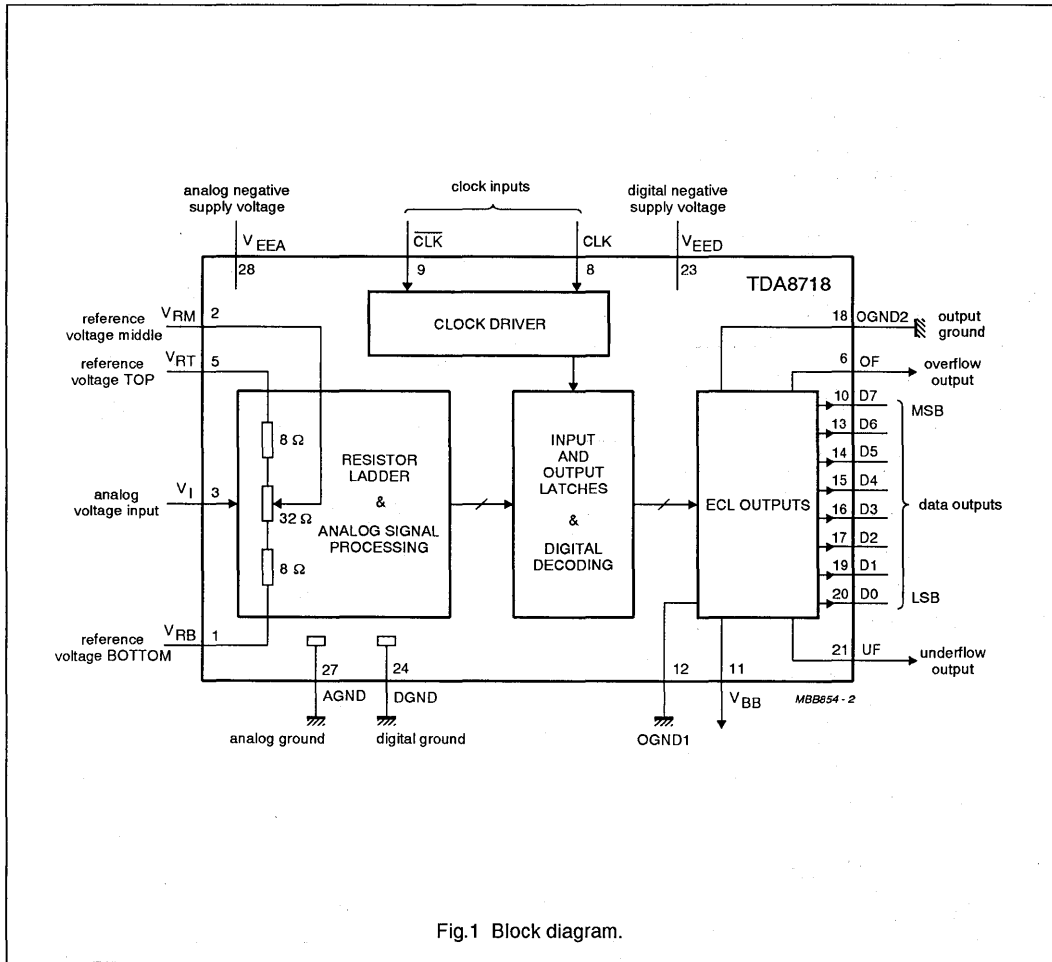

Fig.1 Block diagram.

8-bit high-speed analog-to-digital converter TDA8718

PINNING

SYMBOL	PIN	DESCRIPTION
V <sub>RB</sub>	1	reference voltage BOTTOM
V <sub>RM</sub>	2	reference voltage MIDDLE decoupling
V <sub>I</sub>	3	analog input voltage
n.c.	4	not connected
V <sub>RT</sub>	5	reference voltage TOP
OF	6	overflow digital output
n.c.	7	not connected
CLK	8	clock input
CLK	9	complementary clock input
D7	10	digital output; bit 7 (MSB)
V <sub>BB</sub>	11	ECL reference voltage
OGND1	12	output ground 1 (0 V)
D6	13	digital output; bit 6
D5	14	digital output; bit 5
D4	15	digital output; bit 4
D3	16	digital output; bit 3
D2	17	digital output; bit 2
OGND2	18	output ground 2 (0 V)
D1	19	digital output; bit 1
D0	20	digital output; bit 0 (LSB)
UF	21	underflow digital output
n.c.	22	not connected
V <sub>EED</sub>	23	digital supply voltage (-4.5 V)
DGND	24	digital ground
n.c.	25	not connected
n.c.	26	not connected
AGND	27	analog ground
V <sub>EEA</sub>	28	analog supply voltage (-4.5 V)

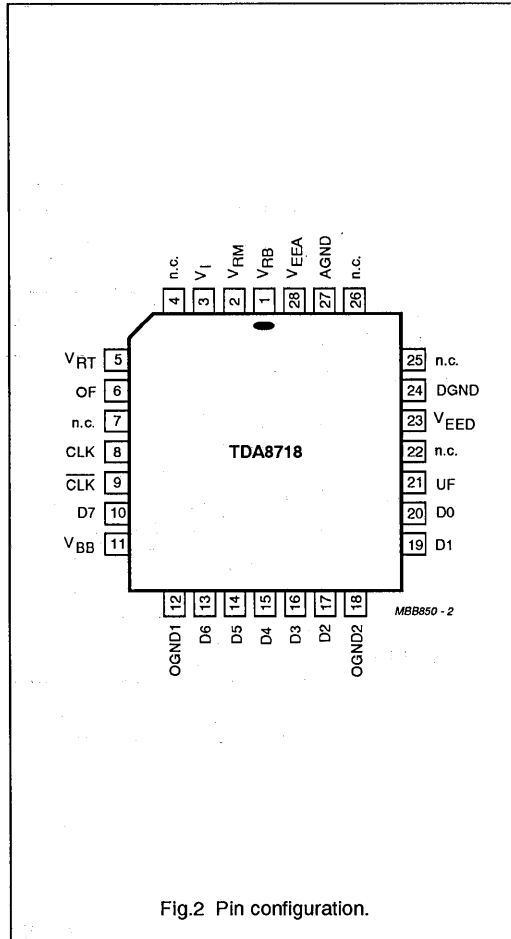

Fig.2 Pin configuration.

8-bit high-speed analog-to-digital converter

TDA8718

**LIMITING VALUES**

In accordance with the Absolute Maximum Rating System (IEC 134).

SYMBOL	PARAMETER	CONDITIONS	MIN.	MAX.	UNIT
$V_{EEA}$	analog supply voltage (pin 28)		-7.0	+0.3	V
$V_{EED}$	digital supply voltage (pin 23)		-7.0	+0.3	V
$\Delta V_{EE}$	supply voltage difference between $V_{EEA}$ and $V_{EED}$		-1.00	+1.0	V
$V_I$	input voltage (pin 3)	referenced to AGND	$V_{EEA}$	0	V
$\Delta V_{clk(p-p)}$	clock input voltage difference between CLK and $\overline{CLK}$ pin 8 to pin 9 (peak-to-peak value)	referenced to $V_{EED}$ ; note 1	-	2.0	V
$I_O$	output current for each digital output		-	30	mA
$T_{stg}$	storage temperature		-55	+150	°C
$T_{amb}$	operating ambient temperature		0	+70	°C
$T_j$	junction temperature		-	+150	°C

**Note**

- The circuit has two clock inputs CLK and  $\overline{CLK}$ . Sampling takes place on the falling edge of the clock input signal; CLK and  $\overline{CLK}$  are two complementary signals.

**THERMAL CHARACTERISTICS**

SYMBOL	PARAMETER	VALUE	UNIT
$R_{th\ j-a}$	thermal resistance from junction to ambient in free air	55	K/W

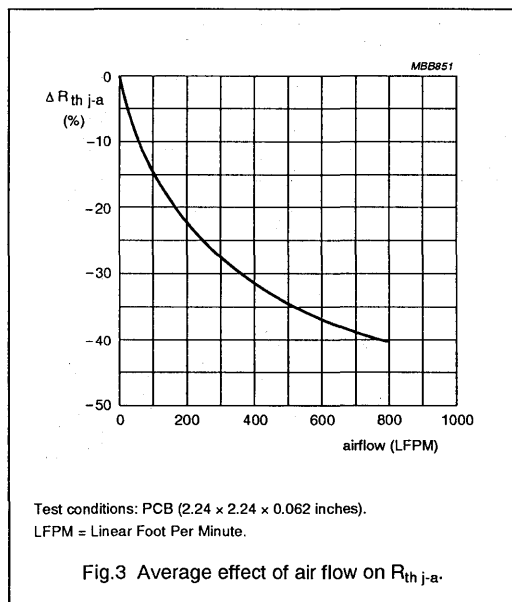

8-bit high-speed analog-to-digital converter

TDA8718

**CHARACTERISTICS**

$V_{EEA} = -4.2$  to  $-4.8$  V;  $V_{EED} = -4.2$  to  $-4.8$  V;  $V_{EEA}$  to  $V_{EED} = -0.1$  to  $+0.1$  V; AGND and DGND shorted together;  $T_{amb} = 0$  to  $+70$  °C; typical values measured at  $V_{EEA} = -4.5$  V,  $V_{EED} = -4.5$  V and  $T_{amb} = 25$  °C; unless otherwise specified.

SYMBOL	PARAMETER	CONDITIONS	MIN.	TYP.	MAX.	UNIT
<b>Supply</b>						
$V_{EEA}$	analog supply voltage (pin 28)		-4.2	-4.5	-4.8	V
$V_{EED}$	digital supply voltage (pin 23)		-4.2	-4.5	-4.8	V
$I_{EEA}$	analog supply current (pin 28)		30	42	54	mA
$I_{EED}$	digital supply current (pin 23)		100	120	150	mA
$I_{EEO(L)}$	LOW level output supply current	$R_L = 50 \Omega$	40	70	90	mA
$I_{EEO(H)}$	HIGH level output supply current	$R_L = 50 \Omega$	155	170	185	mA
<b>Reference voltages for the resistor ladder (see Table 1)</b>						
$I_{RT}$	reference current (pin 5)	$R = 48 \Omega$	30	45	60	mA
$V_{RB}$	reference voltage BOTTOM (pin 1)		-	$48 \Omega \times I_{RT}$	-	V
$V_{RT}$	reference voltage TOP (pin 5)		-	0	-	V
$R_{LAD}$	resistor ladder		-	48	-	$\Omega$
$TC_{RLAD}$	temperature coefficient of the resistor ladder		-	175	-	m $\Omega$ /K
$V_{osB}$	voltage offset BOTTOM	note 1	-	$8 \Omega \times I_{RT}$	-	mV
$V_{osT}$	voltage offset TOP	note 1	-	$8 \Omega \times I_{RT}$	-	mV
<b>Inputs</b>						
CLK INPUT (PIN 8); $\overline{CLK}$ INPUT (PIN 9)						
$V_{iL}$	LOW level input voltage		-	-1.8	-	V
$V_{iH}$	HIGH level input voltage		-	-0.8	-	V
$I_{iL}$	LOW level input current	$V_{clk} = -1.8$ V	-	0	-	$\mu$ A
$I_{iH}$	HIGH level input current	$V_{clk} = -0.8$ V	-	120	-	$\mu$ A
$R_i$	input resistance	$f_{clk} = 100$ MHz	-	1.5	-	k $\Omega$
$C_i$	input capacitance	$f_{clk} = 100$ MHz	-	3.5	-	pF
$\Delta V_{clk(p-p)}$	clock input voltage difference between CLK and $\overline{CLK}$ pin 8 to pin 9 (peak-to-peak value)		-	900	-	mV
ANALOG INPUT (PIN 3); NOTE 2						
$I_{iL}$	LOW level input current	data output = 00	20	40	80	$\mu$ A
$I_{iH}$	HIGH level input current	data output = FF	100	200	400	$\mu$ A
$R_i$	input resistance		-	10	-	k $\Omega$
$C_i$	input capacitance		-	5	-	pF

## 8-bit high-speed analog-to-digital converter

TDA8718

SYMBOL	PARAMETER	CONDITIONS	MIN.	TYP.	MAX.	UNIT
<b>Outputs (<math>R_L = 50 \Omega</math>)</b>						
DIGITAL 100K ECL OUTPUTS (D0 TO D7; OF; UF)						
$V_{OL}$	LOW level output voltage	$T_{amb} = 25^\circ\text{C}$	–	–1770	–1650	mV
$V_{OH}$	HIGH level output voltage	$T_{amb} = 25^\circ\text{C}$	–1300	–1150	–	mV
$V_{ECL}$	ECL reference voltage		–1550	–1450	–1350	mV
$I_{OL}$	LOW level output current		4	6	8	mA
$I_{OH}$	HIGH level output current		10	20	25	mA
<b>Switching characteristics</b>						
$f_{clk(max)}$	maximum clock frequency (pins 8 and 9)		600	–	–	MHz
$t_r; t_f$	rise and fall times	$f_i = 100\text{ MHz}$	–	–	750	ps
<b>Analog signal processing (<math>f_{clk} = 500\text{ MHz}</math>)</b>						
HARMONICS (FULL SCALE)						
$h_1$	fundamental harmonics	$f_i = 100\text{ MHz}$	–	0	–	dB
$h_2$	second harmonics	$f_i = 100\text{ MHz}$	–	–54	–	dB
$h_3$	third harmonics	$f_i = 100\text{ MHz}$	–	–50	–	dB
<b>Transfer function</b>						
ILE	DC integral linearity error		–	$\pm 0.7$	$\pm 1.0$	LSB
DLE	DC differential linearity error		–	$\pm 0.3$	$\pm 0.5$	LSB
AILE	AC integral linearity error	note 3	–	$\pm 0.9$	$\pm 1.5$	LSB
EB	effective bits	$f_i = 4.43\text{ MHz}$ , full scale; $I_{ref} = 45\text{ mA}$ ; note 4; $f_{clk} = 100\text{ MHz}$ ; Fig.5	–	7.5	–	bits
		$f_i = 100\text{ MHz}$ , full scale; $I_{ref} = 45\text{ mA}$ ; note 4; $f_{clk} = 500\text{ MHz}$ ; Fig.6	–	6.5	–	bits
BER	bit error rate	$f_{clk} = 500\text{ MHz}$ ; $f_i = 100\text{ MHz}$ ; $V_i = \pm 8\text{ LSB}$ at code 128; 50% clock duty cycle	–	$10^{-11}$	–	times/ samples
<b>Timing (<math>f_{clk} = 500\text{ MHz}</math>; <math>R_L = 50 \Omega</math>; <math>C_L = 5\text{ pF}</math>) note 5</b>						
$t_{ds}$	sampling delay		–	–	300	ps
$t_h$	output hold time		400	700	–	ps
$t_d$	output delay time		–	1300	1500	ps

8-bit high-speed analog-to-digital converter

TDA8718

Notes to the "Characteristics"

1. Voltage offset BOTTOM ( $V_{osB}$ ) is the difference between the analog input which produces data outputs equal to 00 and the reference voltage BOTTOM ( $V_{RB}$ ) at  $T_{amb} = 25\text{ }^\circ\text{C}$ . Voltage offset TOP ( $V_{osT}$ ) is the difference between reference voltage TOP ( $V_{RT}$ ) and the analog input which produces data outputs equal to FF, at  $T_{amb} = 25\text{ }^\circ\text{C}$ .
2. The analog input is not internally biased. It should be externally biased between  $V_{RT}$  and  $V_{RB}$  levels.
3. Full-scale sine wave;  $f_i = 4.43\text{ MHz}$ ;  $f_{clk} = 100\text{ MHz}$ .
4. Effective bits are obtained via a Fast Fourier Transform (FFT) treatment taking 4K acquisition points per period. The calculation takes into account all harmonics and noise up to half of the clock frequency (NYQUIST frequency). Conversion to signal-to-noise ratio:  $S/N = EB \times 6.02 + 1.76\text{ dB}$ .
5. TDA8718 can only withstand one or two 100K ECL loads in order to work out timings at the maximum sampling frequency. It is recommended to minimize the printed circuit-board load by implementing the load device as close as possible to the TDA8718.

Table 1 Output coding and input voltage (typical values; referenced to AGND).

STEP	$V_i$	O/UF	BINARY OUTPUT BITS					
			D5	D4	D3	D2	D1	D0
Underflow	$< -40\ \Omega \times I_{RT}$	1	0	0	0	0	0	0
0	$-40\ \Omega \times I_{RT}$	0	0	0	0	0	0	0
1	.	0	0	0	0	0	0	1
.	.	.	.	.	.	.	.	.
.	.	.	.	.	.	.	.	.
.	.	.	.	.	.	.	.	.
254	.	0	1	1	1	1	1	0
255	$-8\ \Omega \times I_{RT}$	0	1	1	1	1	1	1
Overflow	$> -8\ \Omega \times I_{RT}$	1	1	1	1	1	1	1

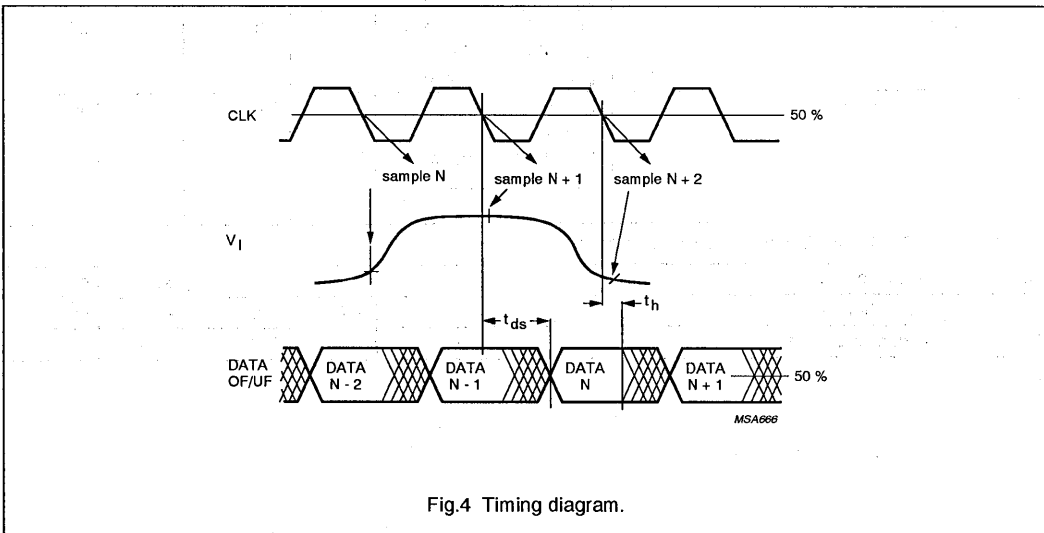
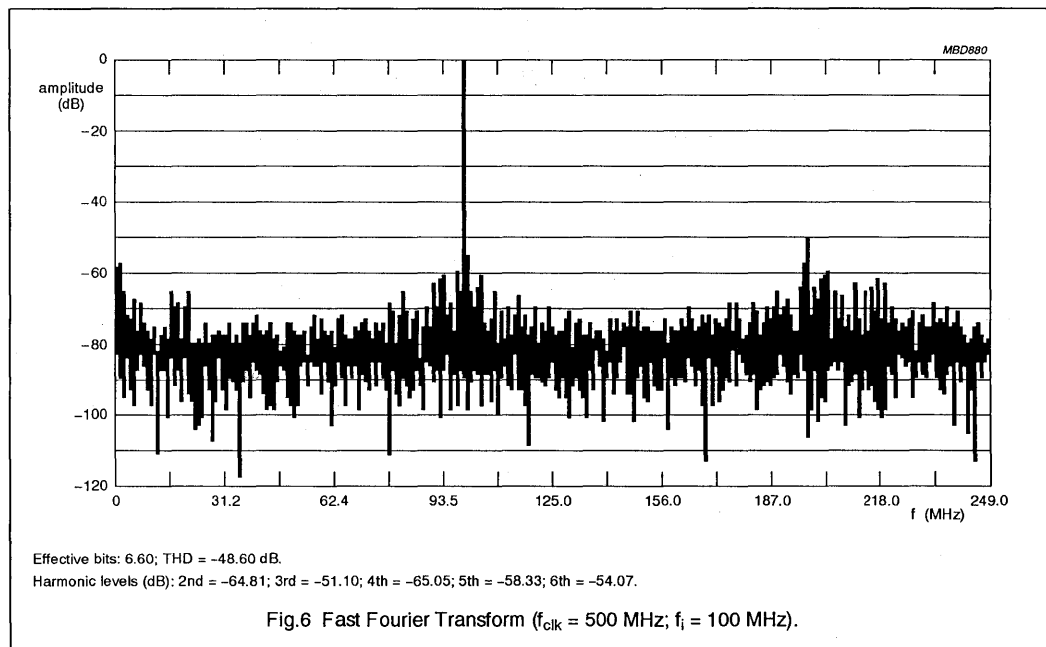
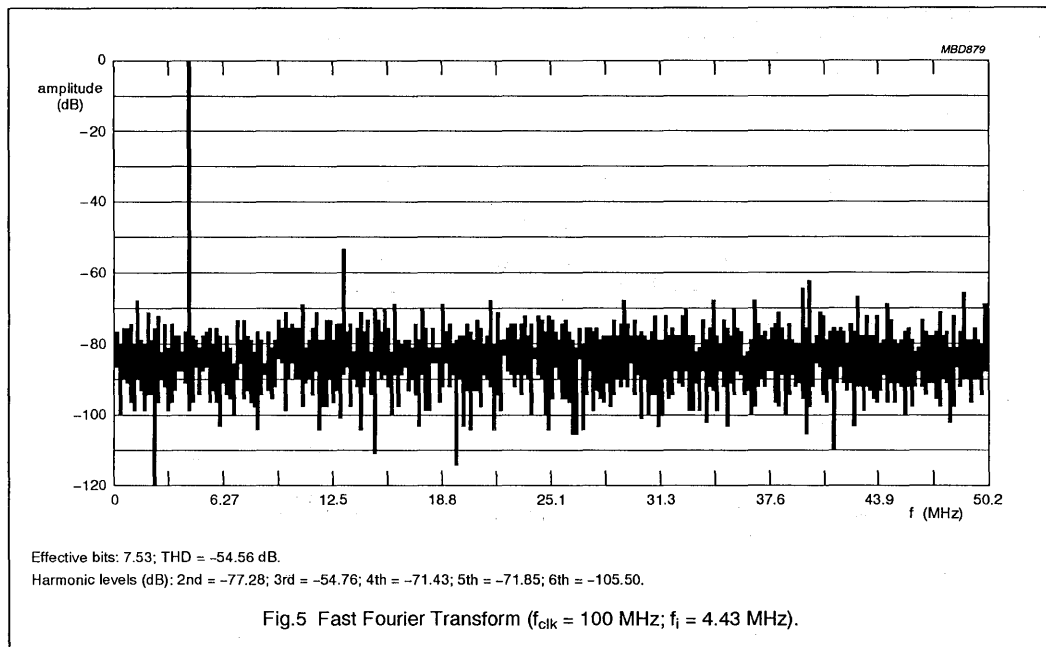

Fig.4 Timing diagram.

8-bit high-speed analog-to-digital converter

TDA8718



8-bit high-speed analog-to-digital converter

TDA8718

APPLICATION INFORMATION

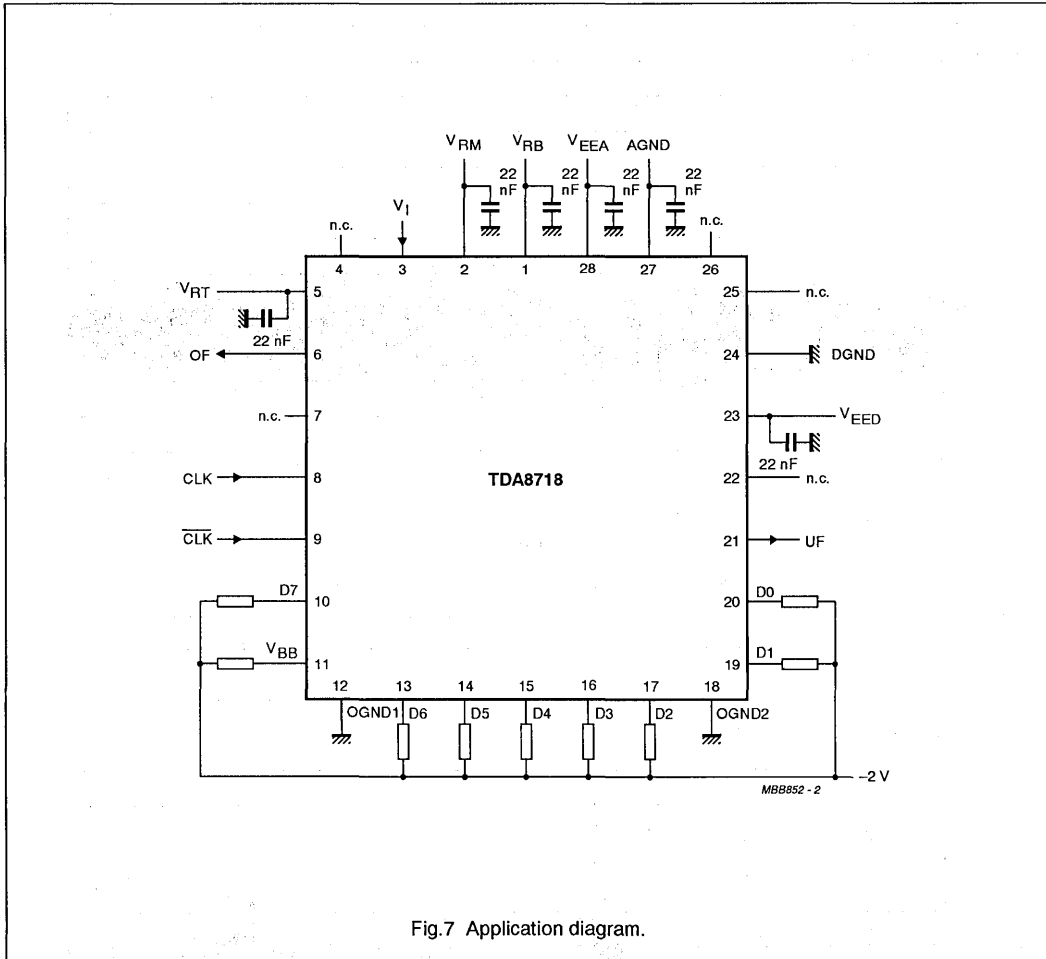

Fig.7 Application diagram.



# YUV 8-bit video low-power analog-to-digital interface

## TDA8755

### FEATURES

- 8-bit resolution
- Sampling rate up to 20 MHz
- TTL compatible digital inputs
- 3-state TTL outputs
- U, V two's complement outputs
- Y binary output
- Power dissipation of 550 mW (typical)
- Low analog input capacitance, no buffer amplifier required
- High signal-to-noise ratio over a large analog input frequency range
- Track-and-hold included
- Clamp functions included
- UV multiplexed ADC
- 4 : 1 : 1 output data encoder
- Stable voltage regulator included.

### APPLICATIONS

- High speed analog-to-digital conversion for video signal digitizing
- 100 Hz improved definition TV (IDTV).

### GENERAL DESCRIPTION

The TDA8755 is a bipolar 8-bit video low-power analog-to-digital conversion (ADC) interface for YUV signals. The device converts the YUV analog input signal into 8-bit coded digital words in a 4 : 1 : 1 format at a sampling rate of 20 MHz. The U/V signals are converted in a multiplexed manner. All analog signal inputs are digitally clamped and a fast precharge is provided for start-up. All digital inputs and outputs are TTL compatible. Frame synchronization is supported in a multiplexed manner.

### QUICK REFERENCE DATA

SYMBOL	PARAMETER	CONDITIONS	MIN.	TYP.	MAX.	UNIT
V <sub>CCA</sub>	analog supply voltage		4.75	5.0	5.25	V
V <sub>CCD</sub>	digital supply voltage		4.75	5.0	5.25	V
V <sub>CCO</sub>	output stages supply voltage		4.75	5.0	5.25	V
I <sub>CCA</sub>	analog supply current		–	46	51	mA
I <sub>CCD</sub>	digital supply current		–	55	61	mA
I <sub>CCO</sub>	output stages supply current		–	9	12	mA
ILE	DC integral linear error	f <sub>clk</sub> = 2 MHz	–	±0.4	±1	LSB
DLE	DC differential linearity error	f <sub>clk</sub> = 2 MHz	–	±0.3	±0.5	LSB
EB	effective bit		–	7.1	–	MHz
f <sub>clk(max)</sub>	maximum clock frequency		20	–	–	MHz
P <sub>tot</sub>	total power dissipation		–	550	650	mW

### ORDERING INFORMATION

TYPE NUMBER	PACKAGE			
	PINS	PIN POSITION	MATERIAL	CODE
TDA8755T	32	SO32L	plastic	SOT287-1

YUV 8-bit video low-power  
analog-to-digital interface

TDA8755

BLOCK DIAGRAM

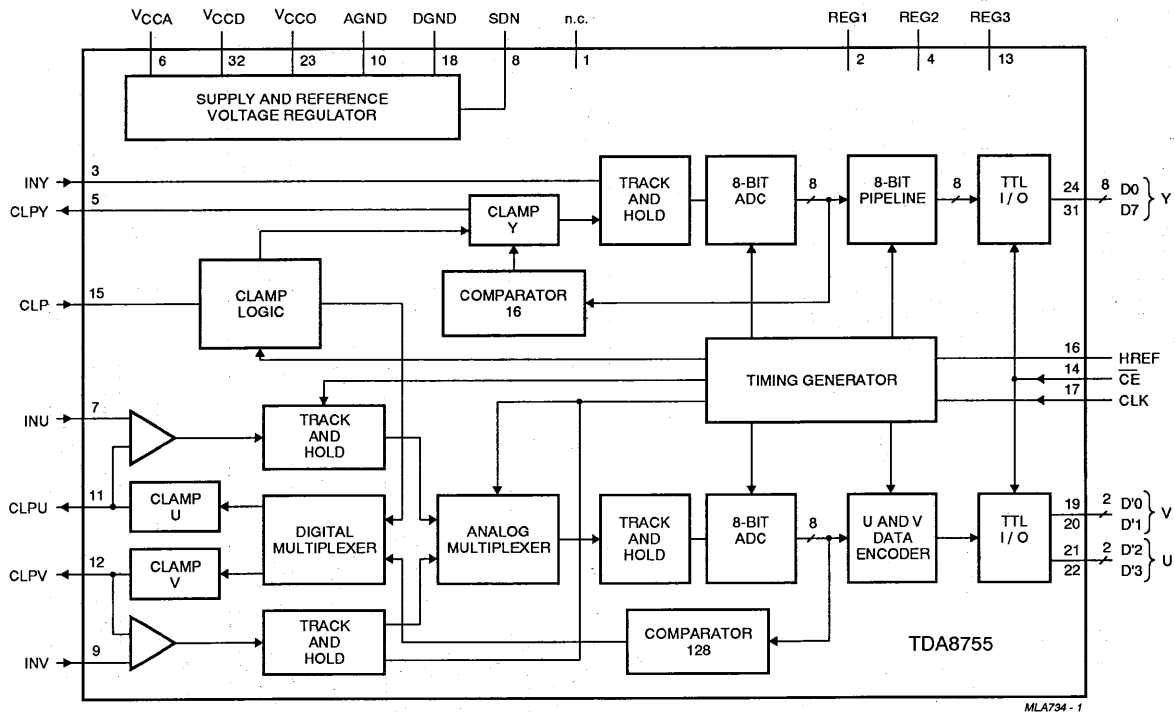

MLA794-1

Fig.1 Block diagram.

# YUV 8-bit video low-power analog-to-digital interface

TDA8755

## PINNING

SYMBOL	PIN	DESCRIPTION
n.c.	1	not connected
REG1	2	decoupling input (internal stabilization loop decoupling)
INY	3	Y analog voltage input
REG2	4	decoupling input (internal stabilization loop decoupling)
CLPY	5	Y clamp capacitor connection
V <sub>CCA</sub>	6	analog positive supply voltage (+5 V)
INU	7	U analog voltage input
SDN	8	stabilizer decoupling node and analog reference voltage (+3.35 V)
INV	9	V analog voltage input
AGND	10	analog ground
CLPU	11	U clamp capacitor connection
CLPV	12	V clamp capacitor connection
REG3	13	decoupling input (internal stabilization loop decoupling)
$\overline{\text{CE}}$	14	chip enable input (TTL level input active LOW)
CLP	15	clamp control input
HREF	16	horizontal reference signal
CLK	17	clock input
DGND	18	digital ground
D'0	19	V data output; bit 0 (n-1)
D'1	20	V data output; bit 1 (n)
D'2	21	U data output; bit 0 (n-1)
D'3	22	U data output; bit 1 (n)
V <sub>CCO</sub>	23	positive supply voltage for output stages (+5 V)
D0	24	Y data output; bit 0 (LSB)
D1	25	Y data output; bit 1
D2	26	Y data output; bit 2
D3	27	Y data output; bit 3
D4	28	Y data output; bit 4
D5	29	Y data output; bit 5
D6	30	Y data output; bit 6
D7	31	Y data output; bit 7 (MSB)
V <sub>CCD</sub>	32	digital positive supply voltage (+5 V)

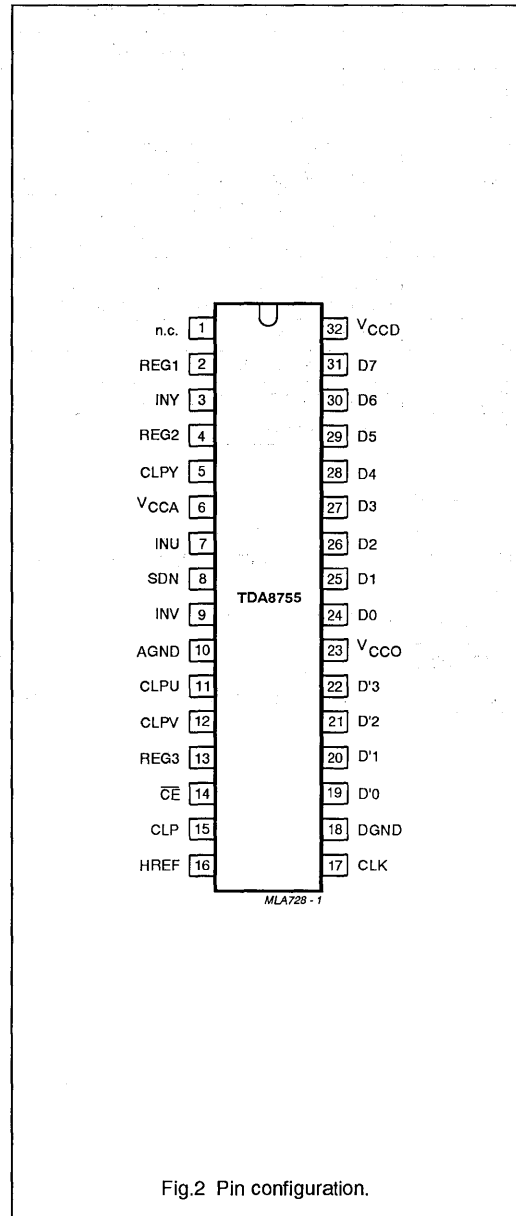

# YUV 8-bit video low-power analog-to-digital interface

TDA8755

## LIMITING VALUES

In accordance with the Absolute Maximum Rating System (IEC134).

SYMBOL	PARAMETER	CONDITIONS	MIN.	MAX.	UNIT
$V_{CCA}$	analog supply voltage		-0.3	+7.0	V
$V_{CCD}$	digital supply voltage		-0.3	+7.0	V
$V_{CCO}$	output stages supply voltage		-0.3	+7.0	V
$\Delta V_{CC}$	supply voltage difference between $V_{CCA}$ and $V_{CCD}$		-1.0	+1.0	V
	supply voltage difference between $V_{CCO}$ and $V_{CCD}$		-1.0	+1.0	V
	supply voltage difference between $V_{CCA}$ and $V_{CCO}$		-1.0	+1.0	V
$V_I$	input voltage	referenced to AGND	-	+5.0	V
$V_{clk(p-p)}$	AC input voltage for switching (peak-to-peak value)	referenced to DGND	-	$V_{CCD}$	V
$I_O$	output current		-	+6	mA
$T_{stg}$	storage temperature		-55	+150	°C
$T_{amb}$	operating ambient temperature		0	+70	°C
$T_j$	junction temperature		-	+150	°C

## HANDLING

Inputs and outputs are protected against electrostatic discharges in normal handling. However, to be totally safe, it is desirable to take normal precautions appropriate to handling integrated circuits.

## THERMAL CHARACTERISTICS

SYMBOL	PARAMETER	VALUE	UNIT
$R_{th j-a}$	thermal resistance from junction to ambient in free air	70	K/W

# YUV 8-bit video low-power analog-to-digital interface

TDA8755

**CHARACTERISTICS**

$V_{CCA} = V_6$  to  $V_{10} = 4.75$  to  $5.25$  V;  $V_{CCD} = V_{32}$  to  $V_{18} = 4.75$  to  $5.25$  V;  $V_{CCO} = V_{23}$  to  $V_{18} = 4.75$  to  $5.25$  V;  
 AGND and DGND shorted together;  $V_{CCA}$  to  $V_{CCD} = -0.25$  to  $+0.25$  V;  $V_{CCO}$  to  $V_{CCD} = -0.25$  to  $+0.25$  V;  
 $V_{CCA}$  to  $V_{CCO} = -0.25$  to  $+0.25$  V;  $T_{amb} = 0$  to  $+70$  °C; typical values measured at  $V_{CCA} = V_{CCD} = V_{CCO} = 5$  V and  
 $T_{amb} = 25$  °C; unless otherwise specified.

SYMBOL	PARAMETER	CONDITIONS	MIN.	TYP.	MAX.	UNIT
<b>Supply</b>						
$V_{CCA}$	analog supply voltage		4.75	5.0	5.25	V
$V_{CCD}$	digital supply voltage		4.75	5.0	5.25	V
$V_{CCO}$	output stages supply voltage		4.75	5.0	5.25	V
$I_{CCA}$	analog supply current		-	46	51	mA
$I_{CCD}$	digital supply current		-	55	61	mA
$I_{CCO}$	output stages supply current		-	9	12	mA
<b>Inputs</b>						
<b>CLK (PIN 17)</b>						
$V_{IL}$	LOW level input voltage		0	-	0.8	V
$V_{IH}$	HIGH level input voltage		2.0	-	$V_{CCD}$	V
$I_{IL}$	LOW level input current	$V_{clk} = 0.4$ V	-400	-	-	$\mu$ A
$I_{IH}$	HIGH level input current	$V_{clk} = 2.7$ V	-	-	100	$\mu$ A
$Z_I$	input impedance	$f_{clk} = 20$ MHz	-	4	-	k $\Omega$
$C_I$	input capacitance	$f_{clk} = 20$ MHz	-	4.5	-	pF
<b><math>\overline{CE}</math>, CLP AND HREF (PINS 14 TO 16)</b>						
$V_{IL}$	LOW level input voltage		0	-	0.8	V
$V_{IH}$	HIGH level input voltage		2.0	-	$V_{CCD}$	V
$I_{IL}$	LOW level input current	$V_{clk} = 0.4$ V	-400	-	-	$\mu$ A
$I_{IH}$	HIGH level input current	$V_{clk} = 2.7$ V	-	-	100	$\mu$ A
<b>CLPY (PIN 5)</b>						
$V_5$	clamp voltage for 16 output code		-	3.725	-	V
$I_5$	clamp output current		-	$\pm 50$	-	$\mu$ A
<b>CLPU AND CLPV (PINS 11 AND 12)</b>						
$V_{11, 12}$	clamp voltage for 128 output code		-	3.30	-	V
$I_{11, 12}$	clamp output current		-	$\pm 50$	-	$\mu$ A
<b>INY (PIN 3)</b>						
$V_{I(p-p)}$	input voltage, full range (peak-to-peak value)	$f_i = 4.43$ MHz	0.93	1.0	1.07	V
$Z_I$	input impedance	$f_i = 6$ MHz	-	30	-	k $\Omega$
$C_I$	input capacitance	$f_i = 6$ MHz	-	1	-	pF

# YUV 8-bit video low-power analog-to-digital interface

TDA8755

SYMBOL	PARAMETER	CONDITIONS	MIN.	TYP.	MAX.	UNIT
<b>INU AND INV (PINS 7 AND 9)</b>						
$V_{I(p-p)}$	input voltage, full range (peak-to-peak value)	$f_i = 1.5 \text{ MHz}$	0.9	1.0	1.1	V
$Z_I$	input impedance	$f_i = 2 \text{ MHz}$	–	30	–	k $\Omega$
$C_I$	input capacitance	$f_i = 2 \text{ MHz}$	–	1	–	pF
<b>INPUTS ISOLATION</b>						
$\alpha_{ct}$	crosstalk between Y, U and V		–	–55	–50	dB
<b>Outputs</b>						
<b>SDN (PIN 8)</b>						
$V_{ref}$	reference voltage		–	3.35	–	V
$V_{REG}$	line regulation	$4.75 \text{ V} \leq V_{CCA} \leq 5.25 \text{ V}$	–	4.0	–	mV
$I_L$	load current		–2	–	–	mA
<b>DIGITAL OUTPUTS D0 TO D7 AND D'0 TO D'3 (PINS 24 TO 31 AND 19 TO 22)</b>						
$V_{OL}$	LOW level output voltage	$I_O = 0.4 \text{ mA}$	0	–	0.4	V
		$I_O = 1.5 \text{ mA}$	0	–	0.5	V
$V_{OH}$	HIGH level output voltage	$I_O = -0.4 \text{ mA}$	2.4	–	$V_{CCD}$	V
$I_{OZ}$	output current in 3-state mode	$0.4 \text{ V} < V_O < V_{CCD}$	–20	–	+20	$\mu\text{A}$
<b>Switching characteristics</b>						
$f_{clk(max)}$	maximum clock frequency		20	–	–	MHz
$f_{clk(min)}$	minimum clock frequency		–	–	2.0	MHz
$t_{CPH}$	clock pulse width HIGH		20	–	–	ns
$t_{CPL}$	clock pulse width LOW		20	–	–	ns
<b>Analog signal processing (<math>f_{clk} = 20 \text{ MHz}</math>; 50% clock duty factor)</b>						
$G_{diff}$	differential gain	note 1; see Fig.8	–	2	–	%
$\Phi_{diff}$	differential phase	note 1; see Fig.8	–	3	–	deg
$f_1$	fundamental harmonics (full-scale)	note 2	–	–	0	dB
$f_{all}$	harmonics (full-scale), all components	note 2; see Fig.10	–	–54	–	dB
SVRR1	supply voltage ripple rejection 1	note 3	–	–40	–	dB
SVRR2	supply voltage ripple rejection 2	note 3	–	1.0	–	%/V
<b>Transfer function (50% clock duty factor)</b>						
ILE	DC integral linearity error	$f_{clk} = 2 \text{ MHz}$	–	$\pm 0.4$	$\pm 1.0$	LSB
DLE	DC differential linearity error	$f_{clk} = 2 \text{ MHz}$	–	$\pm 0.3$	$\pm 0.5$	LSB
AILE	AC integral linearity error	note 4	–	$\pm 1.0$	$\pm 2.0$	LSB
EB	effective bit	note 5; Fig.10	–	7.1	–	bits

# YUV 8-bit video low-power analog-to-digital interface

TDA8755

SYMBOL	PARAMETER	CONDITIONS	MIN.	TYP.	MAX.	UNIT
<b>Timing (note 6; see Figs 3 to 7; <math>f_{clk} = 20</math> MHz)</b>						
$t_{ds}$	sampling delay time		–	1	–	ns
$t_h$	output hold time		7	–	–	ns
$t_d$	output delay time		–	33	42	ns
$t_{dZH}$	3-state output delay time	enable-to-HIGH	–	10	14	ns
$t_{dZL}$	3-state output delay time	enable-to-LOW	–	10	14	ns
$t_{dHZ}$	3-state output delay time	disable-to-HIGH	–	8	11	ns
$t_{dLZ}$	3-state output delay time	disable-to-LOW	–	4	6	ns
$t_r$	clock rise time		3	5	–	ns
$t_f$	clock fall time		3	5	–	ns
$t_{su}$	HREF set-up time		7	–	–	ns
$t_h$	HREF hold time		3	–	–	ns
$t_r$	data output rise time		–	10	–	ns
$t_f$	data output fall time		–	10	–	ns
$t_{CLP}$	minimum time for active clamp	note 7; see Fig.9	3	–	–	$\mu$ s

**Notes**

- Low frequency ramp signal ( $V_{I(p-p)} =$  full-scale and 64  $\mu$ s period) combined with a sine wave input voltage ( $V_{I(p-p)} = 0.25$  full-scale,  $f_i =$  maximum permitted frequency) at the input.
- The input conditions are related as follows:
  - Y channel:  $V_{I(p-p)} = 1.0$  V;  $f_i = 4.43$  MHz
  - U/V channel:  $V_{I(p-p)} = 1.0$  V;  $f_i = 1.5$  MHz.
- Supply voltage ripple rejection:
  - SVRR1 is the variation of the input voltage producing output code 127 (code 15) for supply voltage variation of 0.5 V:

$$SVRR1 = 20 \log \frac{\Delta V_{I(127)}}{\Delta V_{CCA}}$$

- SVRR2 is the relative variation of the full-scale range of analog input for a supply voltage variation of 0.5 V:

$$SVRR2 = \frac{\Delta (V_{I(0)} - V_{I(255)})}{V_{I(0)} - V_{I(255)}} \times \frac{1}{\Delta V_{CCA}}$$

- Full-scale sine wave ( $f_i = 4.43$  MHz for Y and  $f_i = 1.5$  MHz for U and V;  $f_{clk} = 20$  MHz).
- The number of effective bits is measured using a 20 MHz clock frequency. This value is given for a 4.43 MHz input frequency on the Y channel (1.5 MHz on the U and V channels). This value is obtained via a Fast Fourier Transform (FFT) treatment taking  $4 \times T_{clk}$  (clock periods) acquisition points per period. The calculation takes into account all harmonics and noise up to half of the clock frequency (NYQUIST frequency).

Conversion to signal-to-noise ratio:  $S/N = EB \times 6.02 + 1.76$  dB.

- Output data acquisition is available after the maximum delay time of  $t_d$ .
- U and V output data is not valid during  $t_{CLP}$ .

YUV 8-bit video low-power  
analog-to-digital interface

TDA8755

Table 1 Mode selection.

$\overline{CE}$	D7 TO D0; D'3 TO D'0
1	high impedance
0	active; binary

Table 2 Output data coding.

OUTPUT PORT	BIT	OUTPUT DATA			
Y	D7	$Y_{07}$	$Y_{17}$	$Y_{27}$	$Y_{37}$
	D6	$Y_{06}$	$Y_{16}$	$Y_{26}$	$Y_{36}$
	D5	$Y_{05}$	$Y_{15}$	$Y_{25}$	$Y_{35}$
	D4	$Y_{04}$	$Y_{14}$	$Y_{24}$	$Y_{34}$
	D3	$Y_{03}$	$Y_{13}$	$Y_{23}$	$Y_{33}$
	D2	$Y_{02}$	$Y_{12}$	$Y_{22}$	$Y_{32}$
	D1	$Y_{01}$	$Y_{11}$	$Y_{21}$	$Y_{31}$
	D0	$Y_{00}$	$Y_{10}$	$Y_{20}$	$Y_{30}$
U	D'3	$\overline{U}_{07}$	$U_{05}$	$U_{03}$	$U_{01}$
	D'2	$U_{06}$	$U_{04}$	$U_{02}$	$U_{00}$
V	D'1	$\overline{V}_{07}$	$V_{05}$	$V_{03}$	$V_{01}$
	D'0	$V_{06}$	$V_{04}$	$V_{02}$	$V_{00}$

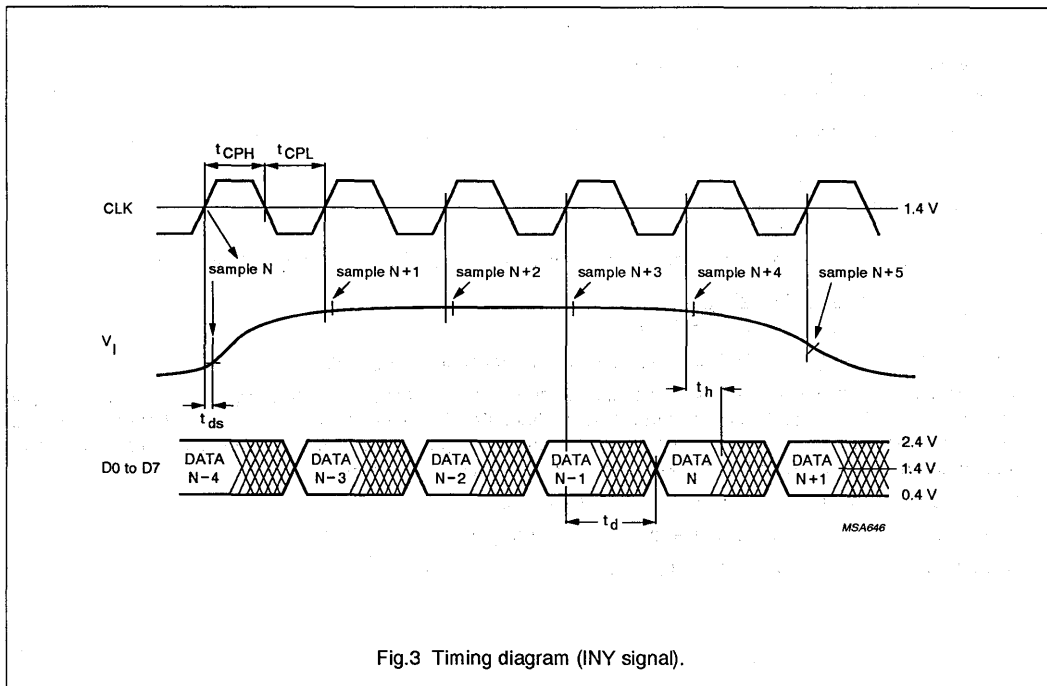

Fig.3 Timing diagram (IN<sub>Y</sub> signal).



YUV 8-bit video low-power  
analog-to-digital interface

TDA8755

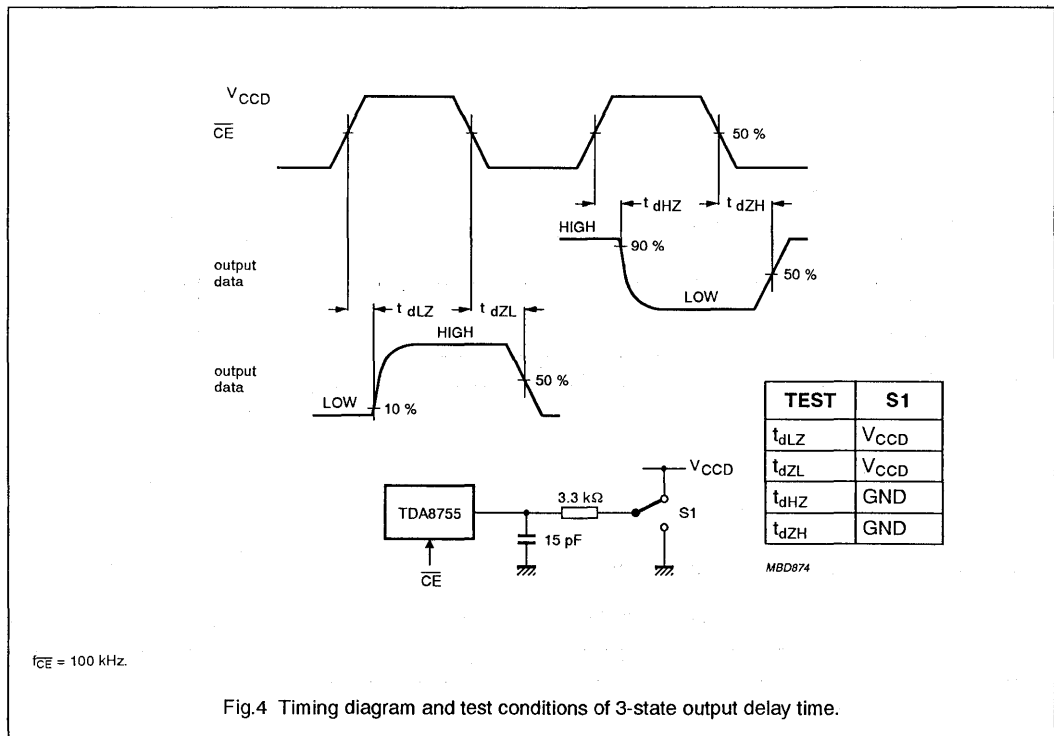

Fig.4 Timing diagram and test conditions of 3-state output delay time.

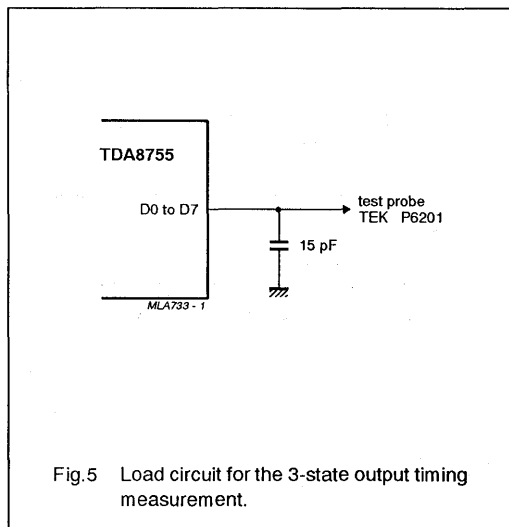
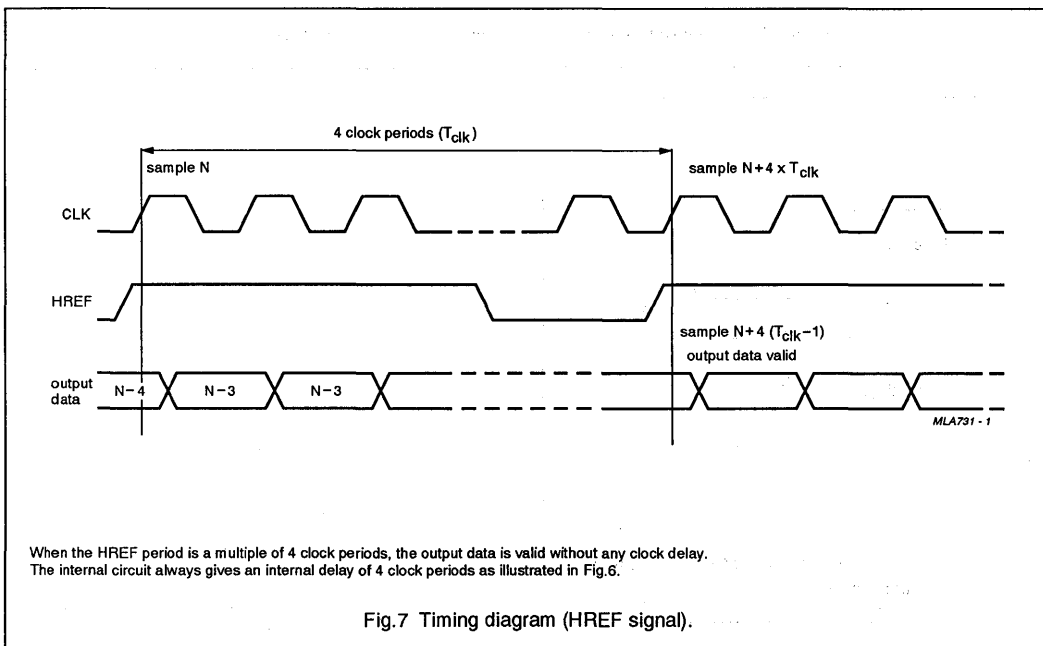
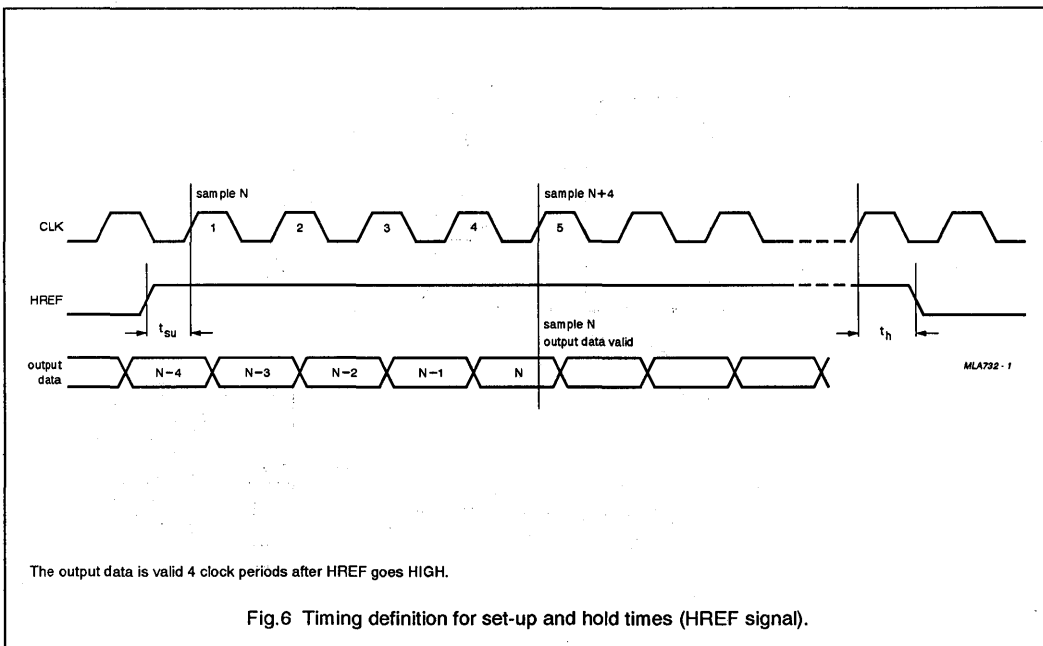

Fig.5 Load circuit for the 3-state output timing measurement.

YUV 8-bit video low-power  
analog-to-digital interface

TDA8755



YUV 8-bit video low-power  
analog-to-digital interface

TDA8755

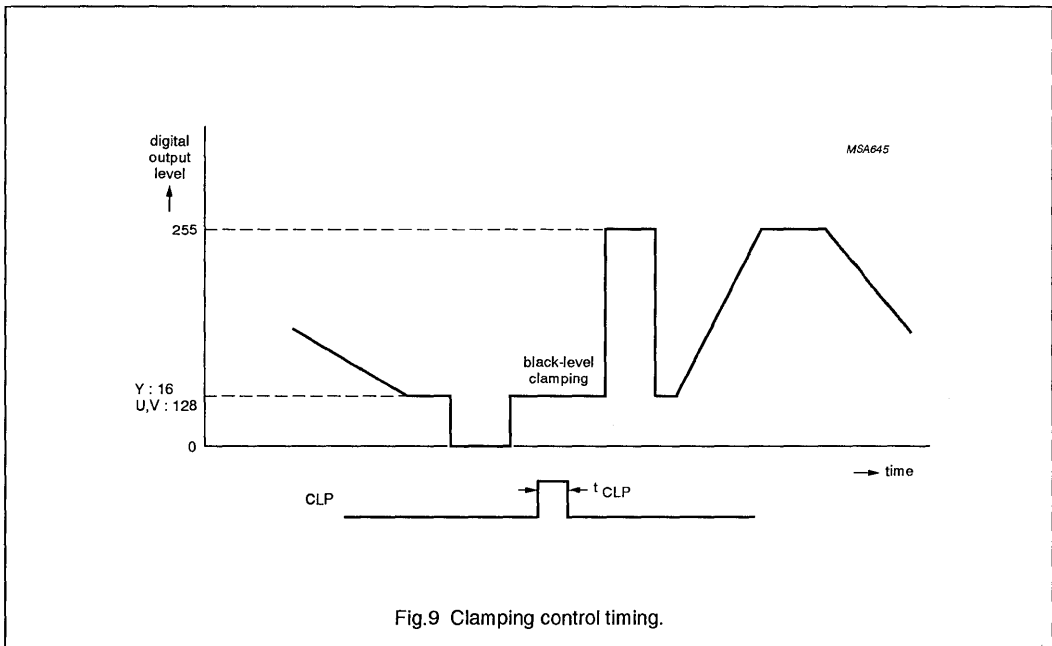
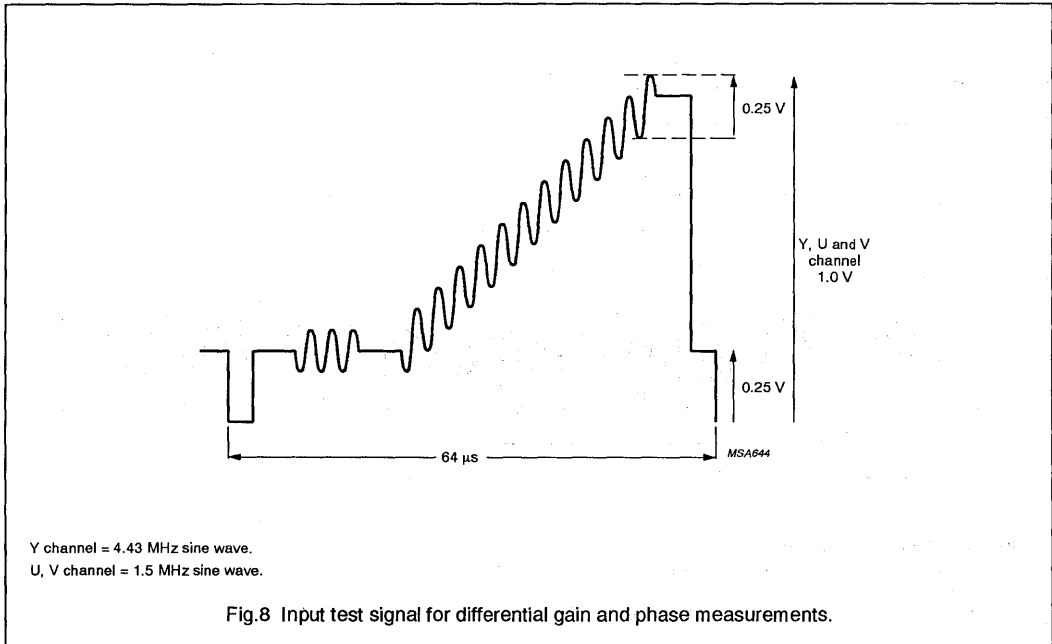

YUV 8-bit video low-power  
analog-to-digital interface

TDA8755

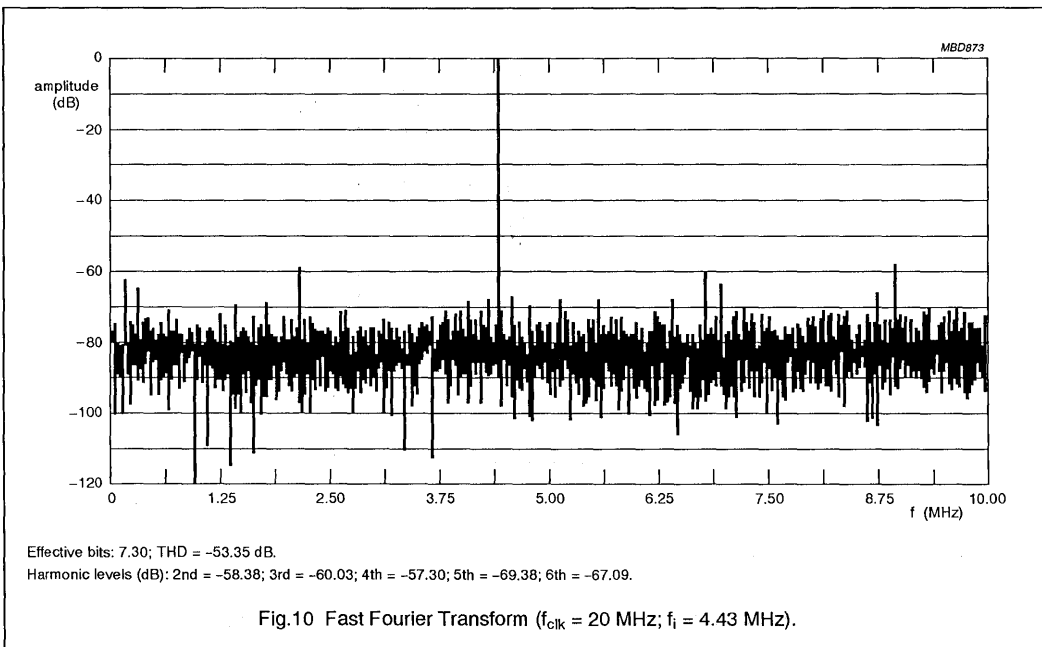

YUV 8-bit video low-power  
analog-to-digital interface

TDA8755

APPLICATION INFORMATION

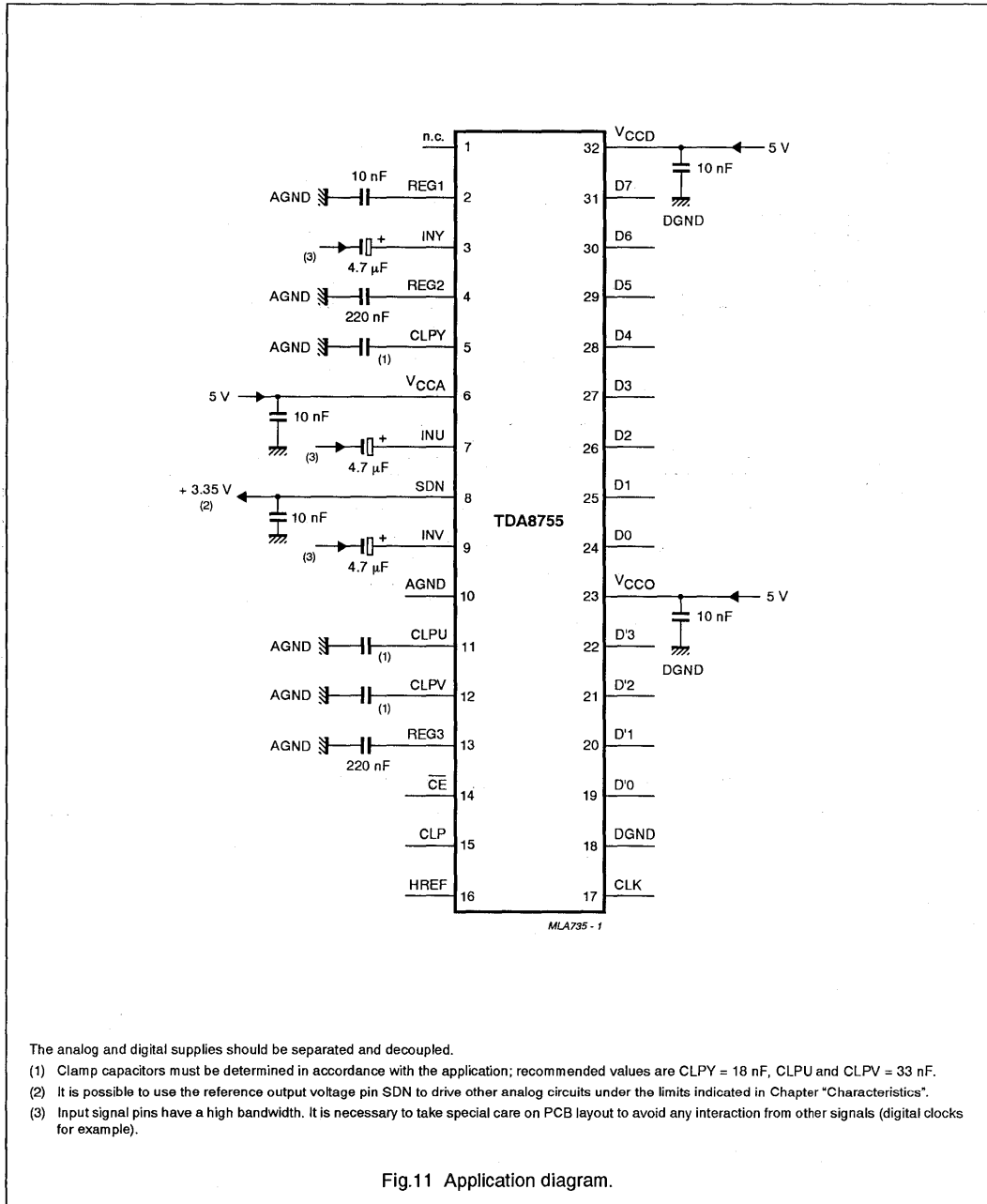

Fig.11 Application diagram.

YUV 8-bit video low-power analog-to-digital interface

TDA8755

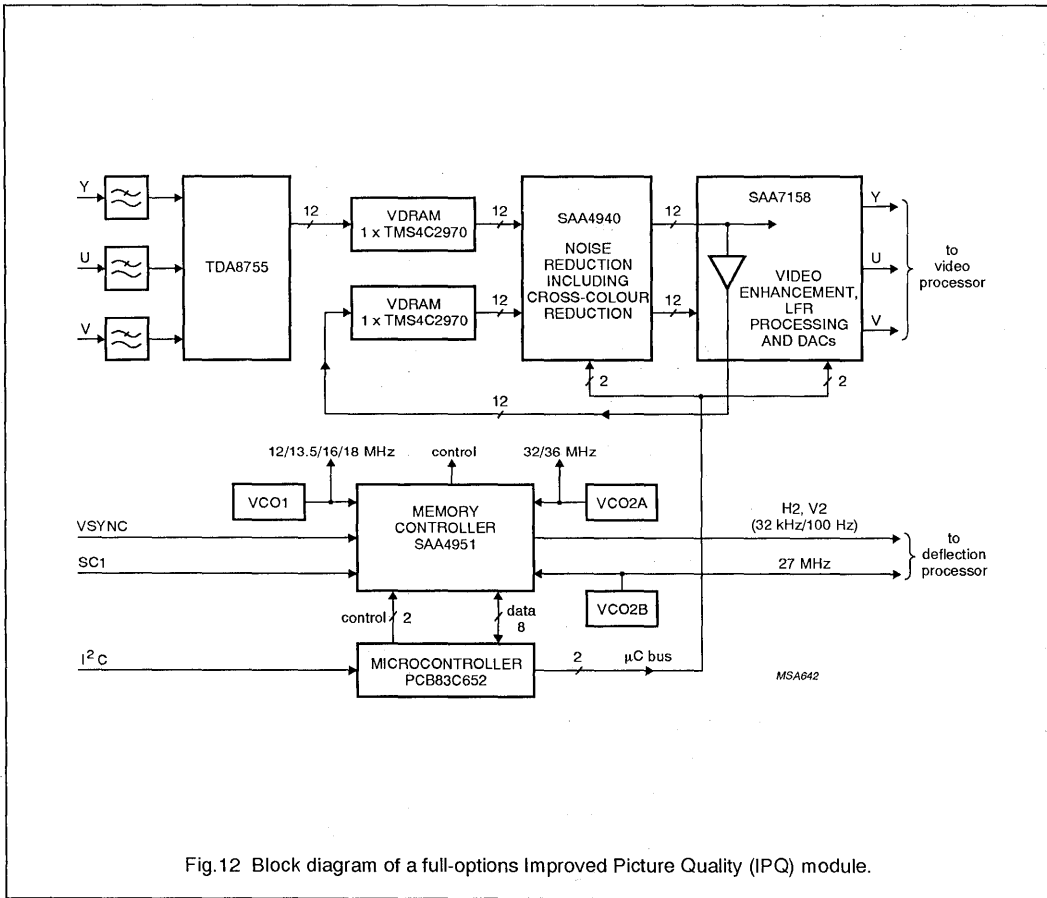

Fig.12 Block diagram of a full-options Improved Picture Quality (IPQ) module.

YUV 8-bit video low-power analog-to-digital interface

TDA8755

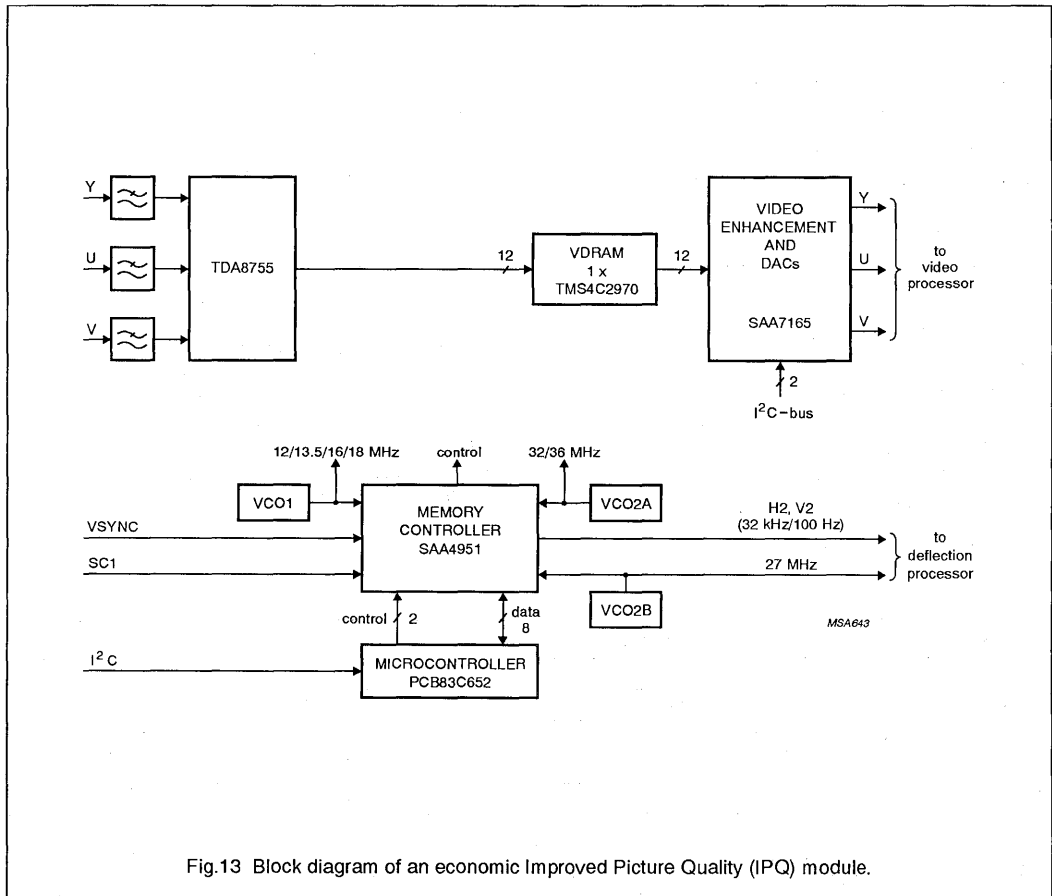

Fig.13 Block diagram of an economic Improved Picture Quality (IPQ) module.

# YC 8-bit low-power analog-to-digital video interface

## TDA8758

### FEATURES

- Two 8-bit ADCs:
  - one Luminance or CVBS channel
  - one Chrominance channel
- Sampling rate up to 32 MHz
- Binary or two's complement 3-state TTL outputs for each channel
- Internal reference voltage regulator
- TTL-compatible digital inputs and outputs
- Power dissipation of 485 mW (typical)
- Input selector circuit (five selectable video inputs for CVBS or YC processing)
- Peak white enable input
- Clamp and Automatic Gain Control (AGC) functions for Y/CVBS channel (clamping on code 64 and Peak White level control at code 255)
- Clamp function for C channel (code 128)
- No sample-and-hold circuit required.

### APPLICATIONS

- Video signal decoding
- Digital picture processing
- Frame grabbing
- Multimedia with the Philips Desktop Video chip set (SAA7151B, SAA7191B, SAA7194, SAA7196 and SAA9051).

### GENERAL DESCRIPTION

The TDA8758 is an 8-bit video high-speed low-power analog-to-digital conversion (ADC) interface for YC and CVBS signal processing. It converts 1-of-3 CVBS input signals or 1-of-2 YC input signals into binary or two's complement words at a sampling rate of 32 MHz. All analog signal inputs are digitally clamped and an ADC interface is provided on the Y/CVBS channel. A fast precharge on clamp and AGC is provided for start-up. All digital inputs and outputs are TTL compatible.

### QUICK REFERENCE DATA

SYMBOL	PARAMETER	CONDITIONS	MIN.	TYP.	MAX.	UNIT
V <sub>CCA</sub>	analog supply voltage		4.75	5.0	5.25	V
V <sub>CCD</sub>	digital supply voltage		4.75	5.0	5.25	V
V <sub>CCO</sub>	output stages supply voltage		4.75	5.0	5.25	V
I <sub>CCA</sub>	analog supply current		–	55	tbf	mA
I <sub>CCD</sub>	digital supply current		–	24	tbf	mA
I <sub>CCO</sub>	output supply current		–	18	tbf	mA
ILE	DC integral linearity error		–	±0.75	tbf	LSB
DLE	DC differential linearity error		–	±0.4	tbf	LSB
EB	effective bits (from video input to digital outputs)	f <sub>clk</sub> = 32 MHz; f <sub>i</sub> = 4.43 MHz	–	7.0	–	bits
f <sub>clk(max)</sub>	maximum clock frequency		30	32	–	MHz
B	maximum –3 dB bandwidth (input preamplifier)	full-scale; 0 dB gain	–	45	–	MHz
α <sub>ct</sub>	crosstalk between Y and C channels		–	–56	–50	dB
P <sub>tot</sub>	total power dissipation		–	485	tbf	mW

### ORDERING INFORMATION

TYPE NUMBER	PACKAGE			
	PINS	PIN POSITION	MATERIAL	CODE
TDA8758G	48	TQFP48	plastic	SOT313-2



YC 8-bit low-power analog-to-digital video interface

TDA8758

BLOCK DIAGRAM

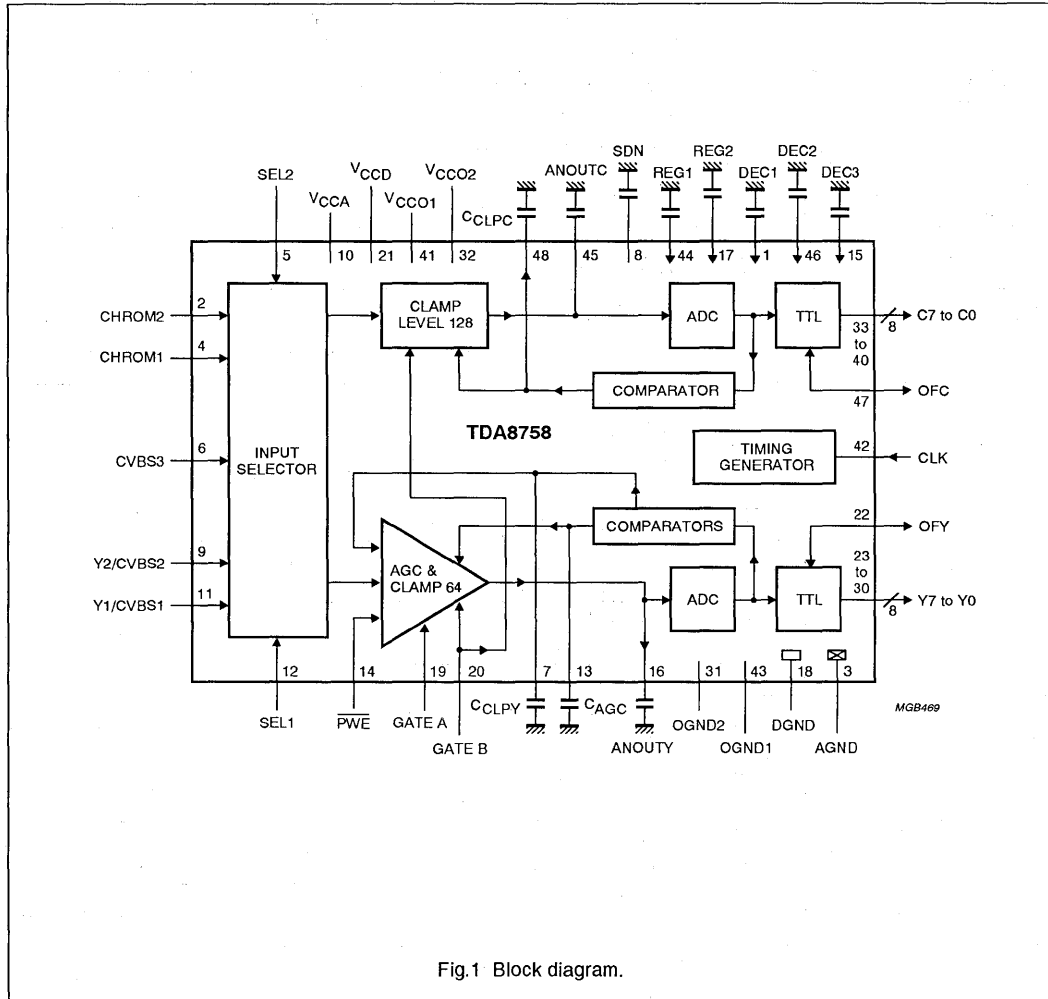

Fig.1 Block diagram.

# YC 8-bit low-power analog-to-digital video interface

TDA8758

## PINNING

SYMBOL	PIN	DESCRIPTION
DEC1	1	decoupling input 1
CHROM2	2	chrominance analog voltage input 2
AGND	3	analog ground
CHROM1	4	chrominance analog voltage input 1
SEL2	5	selection control input 2
CVBS3	6	luminance analog voltage input 3
C <sub>CLPY</sub>	7	Y channel clamping capacitor
SDN	8	stabilizer decoupling node
Y2/CVBS2	9	luminance analog voltage input 2
V <sub>CCA</sub>	10	analog supply voltage (+5 V)
Y1/CVBS1	11	luminance analog voltage input 1
SEL1	12	selection control input 1
C <sub>AGC</sub>	13	AGC capacitor
PWE	14	peak white enable input (active LOW)
DEC3	15	decoupling input 3
ANOUTY	16	analog output for Y channel
REG2	17	decoupling input 2 (internal stabilization loop decoupling)
DGND	18	digital ground
GATE A	19	AGC control input
GATE B	20	clamp control input
V <sub>CCD</sub>	21	digital supply voltage (+5 V)
OFY	22	Y channel output format/chip enable (3-state input)
Y7	23	Y channel data output; bit 7 (MSB)
Y6	24	Y channel data output; bit 6
Y5	25	Y channel data output; bit 5
Y4	26	Y channel data output; bit 4
Y3	27	Y channel data output; bit 3
Y2	28	Y channel data output; bit 2
Y1	29	Y channel data output; bit 1
Y0	30	Y channel data output; bit 0 (LSB)
OGND2	31	output ground 2
V <sub>CCO2</sub>	32	output supply voltage 2 (+5 V)
C7	33	C channel data output; bit 7 (MSB)
C6	34	C channel data output; bit 6
C5	35	C channel data output; bit 5
C4	36	C channel data output; bit 4
C3	37	C channel data output; bit 3
C2	38	C channel data output; bit 2
C1	39	C channel data output; bit 1
C0	40	C channel data output; bit 0 (LSB)

YC 8-bit low-power analog-to-digital video interface

TDA8758

SYMBOL	PIN	DESCRIPTION
V <sub>CCO1</sub>	41	output supply voltage 1 (+5 V)
CLK	42	clock input
OGND1	43	output ground 1
REG1	44	decoupling input 1 (internal stabilization loop decoupling)
ANOUTC	45	analog output for C channel
DEC2	46	decoupling input 2
OFC	47	C channel output format/chip enable (3-state input)
C <sub>CLPC</sub>	48	C channel clamping capacitor

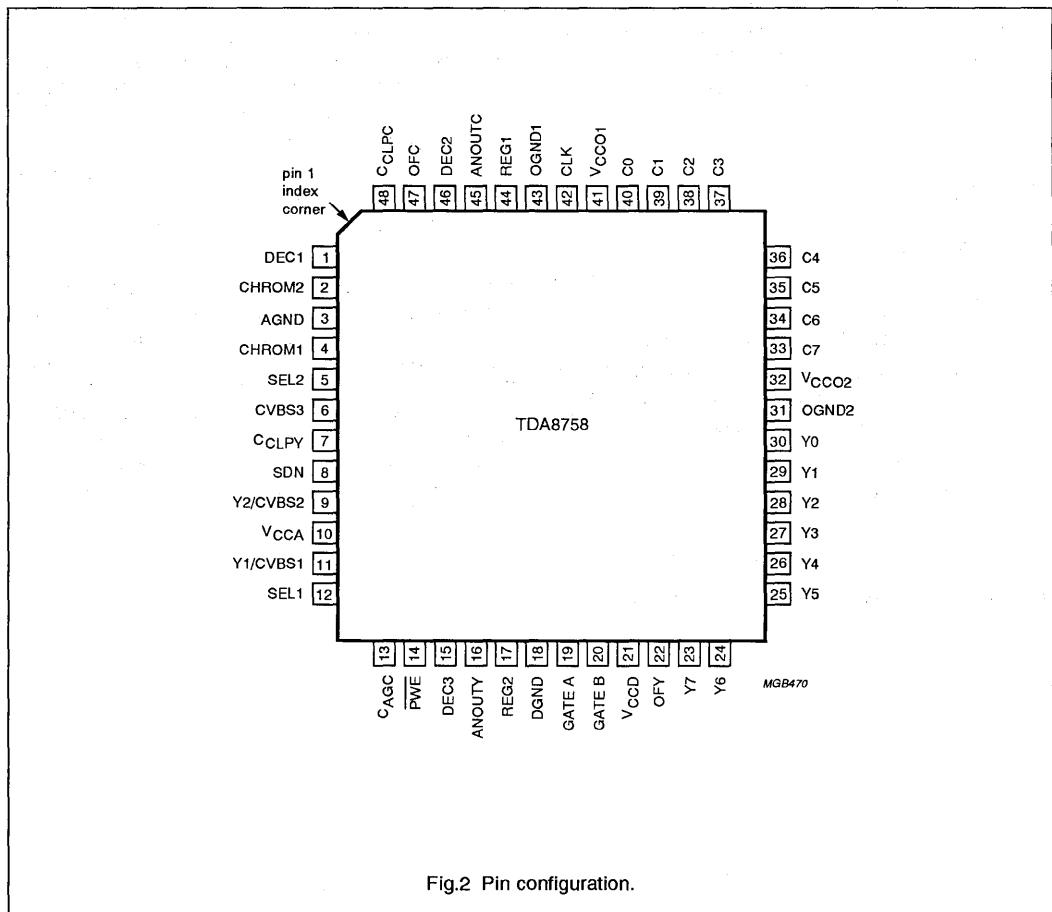

Fig.2 Pin configuration.

# YC 8-bit low-power analog-to-digital video interface

TDA8758

## FUNCTIONAL DESCRIPTION

The TDA8758 provides a simple interface between CVBS or Y/C analog signals and a digital colour decoder.

### Video inputs selection

The input selector allows a choice from different video sources, and has one of the following configurations:

- A: Two Y/C and one CVBS signals
- B: One Y/C and two CVBS signals
- C: Three CVBS signals (only the Y channel is used).

The wiring of the five video inputs (pins 2, 4, 6, 9 and 11) and the control of the two selection inputs (pins 5 and 12) will depend on the available video sources.

- In configuration A, connect as follows:

- Y1 to pin 11
- C1 to pin 4
- Y2 to pin 9
- C2 to pin 2
- CVBS3 to pin 6.

Keep SEL2 (pin 5) LOW and select Y1/C1 or Y2/C2 by switching SEL1 (pin 12).

CVBS3 is selected with SEL1 and SEL2 HIGH.

- In configuration B, replace Y1 (or Y2) by a CVBS input (no more C1 or C2). The selection mode is the same.
- In configuration C, connect as follows:
  - CVBS1 to pin 11
  - CVBS2 to pin 9
  - CVBS3 to pin 6.

Use both SEL1 and SEL2 to select inputs.

**Remark:** the video inputs selection is a static selection.

## Synchronization pulses

GATE A and GATE B pulses are synchronization pulses occurring during the sync period and rear porch respectively. They should be distinct.

On the Y channel, the digital output of the ADC is compared to internal digital reference levels. The resultant outputs control the charge or discharge current of a capacitor connected to the  $C_{AGC}$  pin. The voltage across this capacitor controls the gain of the video amplifier. This is the control loop.

The sync level comparator is active during a positive-going pulse at the GATE A input. This means that sync pulse of the composite video signal is used as an amplitude reference. The bottom of the sync pulse is adjusted to obtain a digital output of logic 1 at the converter Y output. As the black level is digital level 64, the sync pulse will have a digital amplitude of 64 LSBs.

The Peak White control loop is active when the selection pin  $PWE$  is LOW. Then, if the Y video signal exceeds the digital code of 255, it will be limited to avoid any over-range of the converter.

The clamp level control is accomplished by using the same techniques as used for the gain control. On both Y and C channels, the black level digital comparators are active during a positive-going pulse at the GATE B input. On the Y channel, the clamping capacitor connected to the  $C_{CLPY}$  pin will be charged or discharged to adjust the digital output to code 64. On the C channel, the clamping capacitor connected to the  $C_{CLPC}$  pin will be charged or discharged to adjust the digital output to code 128.

# YC 8-bit low-power analog-to-digital video interface

TDA8758

## LIMITING VALUES

In accordance with the Absolute Maximum Rating System (IEC 134).

SYMBOL	PARAMETER	CONDITIONS	MIN.	MAX.	UNIT
$V_{CCA}$	analog supply voltage		-0.3	+7.0	V
$V_{CCD}$	digital supply voltage		-0.3	+7.0	V
$V_{CCO}$	output supply voltage		-0.3	+7.0	V
$\Delta V_{CC}$	supply voltage difference between $V_{CCA}$ and $V_{CCD}$		-1.0	+1.0	V
	supply voltage difference between $V_{CCO}$ and $V_{CCD}$		-1.0	+1.0	V
	supply voltage difference between $V_{CCA}$ and $V_{CCO}$		-1.0	+1.0	V
$V_I$	input voltage	referenced to AGND	-	5.0	V
$V_{cik(p-p)}$	AC input voltage for switching (peak-to-peak value)	referenced to DGND	-	$V_{CCO}$	V
$I_O$	output current		-	+6	mA
$T_{stg}$	storage temperature		-55	+150	°C
$T_{amb}$	operating ambient temperature		0	+70	°C
$T_j$	junction temperature		-	+150	°C

## THERMAL CHARACTERISTICS

SYMBOL	PARAMETER	VALUE	UNIT
$R_{th j-a}$	thermal resistance from junction to ambient in free air	75	K/W

# YC 8-bit low-power analog-to-digital video interface

TDA8758

## CHARACTERISTICS

$V_{CCA} = V_{10}$  to  $V_3 = 4.75$  to  $5.25$  V;  $V_{CCD} = V_{21}$  to  $V_{18} = 4.75$  to  $5.25$  V;  $V_{CCO1} = V_{41}$  to  $V_{43} = 4.75$  to  $5.25$  V;  $V_{CCO2} = V_{32}$  to  $V_{31} = 4.75$  to  $5.25$  V; AGND and DGND shorted together;  $V_{CCA}$  to  $V_{CCD} = -0.25$  to  $+0.25$  V;  $V_{CCO}$  to  $V_{CCD} = -0.25$  to  $+0.25$  V;  $V_{CCA}$  to  $V_{CCO} = -0.25$  to  $+0.25$  V;  $T_{amb} = 0$  to  $+70$  °C; typical values measured at  $V_{CCA} = V_{CCD} = V_{CCO} = 5$  V and  $T_{amb} = 25$  °C; unless otherwise specified.

SYMBOL	PARAMETER	CONDITIONS	MIN.	TYP.	MAX.	UNIT
<b>Supplies</b>						
$V_{CCA}$	analog supply voltage		4.75	5.0	5.25	V
$V_{CCD}$	digital supply voltage		4.75	5.0	5.25	V
$V_{CCO}$	output stages supply voltage		4.75	5.0	5.25	V
$I_{CCA}$	analog supply current		–	55	–	mA
$I_{CCD}$	digital supply current		–	24	–	mA
$I_{CCOtot}$	total output supply current	see Fig.8	–	18	–	mA
<b>Video amplifier inputs</b>						
Y1/CVBS1, Y2/CVBS2, CVBS3, CHROM1 AND CHROM2 INPUTS						
$V_{I(p-p)}$	input voltage (peak-to-peak value)	AGC load with external capacitor; note 1	0.7	–	1.4	V
$ Z_i $	input impedance	$f_i = 6$ MHz	–	20	–	k $\Omega$
$C_i$	input capacitance	$f_i = 6$ MHz	–	1	–	pF
SEL1 AND SEL2 TTL INPUTS (SEE TABLE 1)						
$V_{IL}$	LOW level input voltage		0	–	0.8	V
$V_{IH}$	HIGH level input voltage		2.0	–	$V_{CCD}$	V
$I_{IL}$	LOW level input current	$V_i = 0.4$ V	–400	–	–	$\mu$ A
$I_{IH}$	HIGH level input current	$V_i = 2.7$ V	–	–	20	$\mu$ A
GATE A AND GATE B TTL INPUTS (SEE FIGS 5 AND 6)						
$V_{IL}$	LOW level input voltage		0	–	0.8	V
$V_{IH}$	HIGH level input voltage		2.0	–	$V_{CCD}$	V
$I_{IL}$	LOW level input current	$V_i = 0.4$ V	–400	–	–	$\mu$ A
$I_{IH}$	HIGH level input current	$V_i = 2.7$ V	–	–	20	$\mu$ A
AGC INPUT (PIN 13)						
$V_{13(min)}$	AGC voltage for minimum gain		–	3.0	–	V
$V_{13(max)}$	AGC voltage for maximum gain		–	3.35	–	V
$I_{12}$	AGC output current		see Table 2			
C-CHANNEL CLAMP INPUT (PIN 48)						
$V_{48}$	CLAMP voltage for code 128 output		–	3.4	–	V
$I_{48}$	CLAMP output current		see Table 3			
Y-CHANNEL CLAMP INPUT (PIN 7)						
$V_7$	CLAMP voltage for code 64 output		–	3.65	–	V
$I_7$	CLAMP output current		see Table 3			

# YC 8-bit low-power analog-to-digital video interface

TDA8758

SYMBOL	PARAMETER	CONDITIONS	MIN.	TYP.	MAX.	UNIT
<b>Video amplifier dynamic characteristics</b>						
$\alpha_{ct}$	crosstalk between video inputs (pins 2, 4, 6, 9 and 11)	$V_{CCA} = 4.75$ to $5.25$ V	–	–50	–45	dB
B	–3 dB bandwidth		–	45	–	MHz
S/N	signal-to-noise ratio	note 3	60	–	–	dB
SVRR1	supply voltage ripple rejection	note 4	–	45	–	dB
$\Delta G$	gain range		–3	–	+3	dB
$G_{stab}$	gain stability as a function of supply voltage and temperature		–	–	5	%
<b>Analog-to-digital converter inputs</b>						
CLK INPUT (PIN 42)						
$V_{IL}$	LOW level input voltage		0	–	0.8	V
$V_{IH}$	HIGH level input voltage		2.0	–	$V_{CCD}$	V
$I_{IL}$	LOW level input current	$V_{clk} = 0.4$ V	–400	–	–	$\mu A$
$I_{IH}$	HIGH level input current	$V_{clk} = 2.7$ V	–	–	100	$\mu A$
$ Z_i $	input impedance	$f_{clk} = 10$ MHz	–	4	–	k $\Omega$
$C_i$	input capacitance	$f_{clk} = 10$ MHz	–	4.5	–	pF
OFC AND OFC INPUTS (3-STATE; SEE TABLE 4)						
$V_{IL}$	LOW level input voltage		0	–	0.2	V
$V_{IH}$	HIGH level input voltage		2.6	–	$V_{CCD}$	V
$V_i$	input voltage in high impedance state		–	1.15	–	V
$I_{iL}$	LOW level input current		–370	–300	–	$\mu A$
$I_{iH}$	HIGH level input current		–	300	450	$\mu A$
<b>Analog-to-digital converter outputs</b>						
ANOUTY AND ANOUTC OUTPUTS (PINS 16 AND 45; SEE TABLE 5)						
$V_{ANOUT}$	output voltage	digital output = 00	–	2.6	–	V
$V_{ANOUT}$	output voltage	digital output = 255	–	3.6	–	V
$V_{ANOUT(p-p)}$	output voltage amplitude (peak-to-peak value)		–	1.0	–	V
$I_{ANOUTmax}$	maximum output current		–	–	tbody	$\mu A$
$ Z_{node} $	node impedance	$f_i = 6$ MHz	–	200	–	$\Omega$
$C_{node}$	node capacitance	$f_i = 6$ MHz	–	4	–	pF
DIGITAL OUTPUTS Y0 TO Y7, C0 TO C7						
$V_{OL}$	LOW level output voltage	$I_{OL} = 2$ mA	0	–	0.6	V
$V_{OH}$	HIGH level output voltage	$I_{OL} = -0.4$ mA	2.4	–	$V_{CCD}$	V
<b>Switching characteristics; see Fig.7</b>						
$f_{clk(max)}$	CLK input maximum frequency	note 5	30	32	–	MHz
$t_{CPH}$	clock pulse width HIGH		12	–	–	ns
$t_{CPL}$	clock pulse with LOW		12	–	–	ns

# YC 8-bit low-power analog-to-digital video interface

TDA8758

SYMBOL	PARAMETER	CONDITIONS	MIN.	TYP.	MAX.	UNIT
<b>Analog signal processing from video input to digital output on both channels; 0 dB gain (<math>f_{clk} = 32</math> MHz)</b>						
ILE	DC integral linearity error		-	±0.75	tbf	LSB
DLE	DC differential linearity error		-	±0.4	tbf	LSB
ILE	AC integral linearity error	$f_i = 4.43$ MHz	-	±1.5	tbf	LSB
THD	total harmonic distortion	note 2	-	-52	-	dB
EB	effective bits	$f_i = 4.43$ MHz; note 7	-	7.0	-	bits
$G_{diff}$	differential gain	$V_{16,45} = 1.0$ V (p-p); see Fig.4	-	3	-	%
$\varphi_{diff}$	differential phase	see Fig.4	-	1	-	deg
SVRR2	supply voltage ripple rejection	note 6	-	-	5	%/V
<b>Timing (<math>f_{clk} = 32</math> MHz; see Fig.7)</b>						
DIGITAL OUTPUTS ( $C_L = 15$ pF)						
$t_{ds}$	sampling delay time		-	1.5	-	ns
$t_h$	output hold time		7	-	-	ns
$t_d$	output delay time		-	-	16	ns
$t_w$	clamp pulse width	see Figs 5 and 6	2	3	-	µs

**Notes**

- 0 dB is obtained at the AGC amplifier when applying  $V_{I(p-p)} = 1.0$  V.
- THD (total harmonic distortion) is obtained with the addition of the first five harmonics:

$$THD = 20 \log \frac{F}{\sqrt{(2nd)^2 + (3rd)^2 + (4th)^2 + (5th)^2 + (6th)^2}}$$

F being the fundamental harmonic referenced at 0 dB for a full-scale sine wave input.

- Signal-to-noise ratio measured with 5 MHz bandwidth:

$$\frac{S}{N} = 20 \log \frac{V_{ANOUTC(p-p)}}{V_{ANOUTY(RMS\ noise)}} \text{ at } B = 5 \text{ MHz with } V_{ANOUT} = V_{ANOUTC} \text{ or } V_{ANOUTY} \text{ respectively.}$$

- The supply voltage ripple rejection is expressed as:

$$SVRR1 = 20 \log \frac{\Delta V_{CCA}}{V_{CCA}} \times \frac{G}{\Delta G} \text{ for } V_I = 1 \text{ V (p-p), gain at } 100 \text{ kHz} = 1 \text{ and } 1 \text{ V supply variation.}$$

- It is recommended that the rise and fall times of the clock are  $\geq 1$  ns. In addition, a 'good layout' for the digital and analog grounds is recommended.
- The supply voltage ripple rejection is the relative variation of the analog signal (full-scale signal at input) for 0.5 V of supply variation:

$$SVRR2 = \frac{\Delta(V_{I(00)} - V_{I(FF)}) + (V_{I(00)} - V_{I(FF)})}{\Delta V_{CCA}}$$

- Effective bits are obtained via a Fast Fourier Transform (FFT) treatment taking  $8 \times T_{clk}$  (clock periods) acquisition points per period. The calculation takes into account all harmonics and noise up to half of the clock frequency (NYQUIST frequency). Conversion to signal-to-noise ratio:  $S/N = EB \times 6.02 + 1.76$  dB.



YC 8-bit low-power analog-to-digital video interface

TDA8758

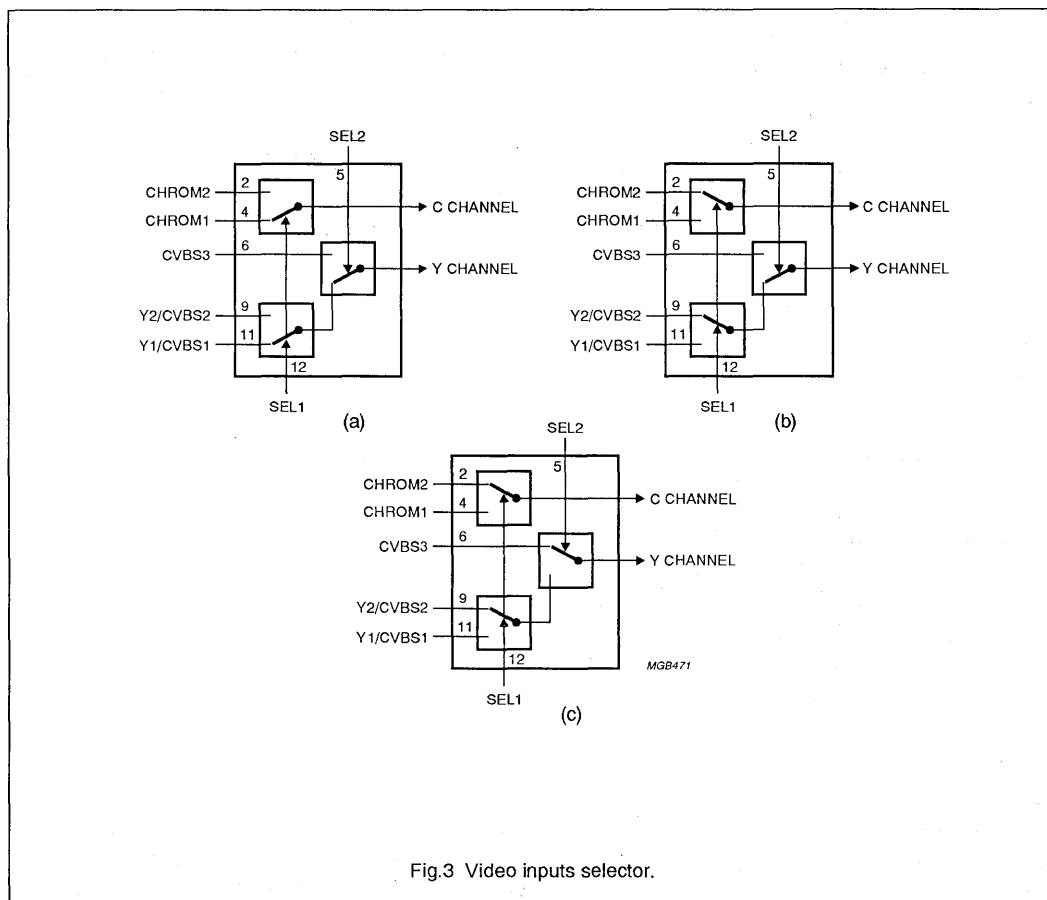

Fig.3 Video inputs selector.

Table 1 Video input selection.

SEL1	SEL2	Y-CHANNEL	C-CHANNEL	FIGURE 3
0	X <sup>(1)</sup>	Y1/CVBS1	CHROM1	(a)
1	0	Y2/CVBS2	CHROM2	(b)
1	1	CVBS3	CHROM2	(c)

Note

1. X = don't care.

# YC 8-bit low-power analog-to-digital video interface

TDA8758

**Table 2** AGC output current.

$\overline{\text{PWE}}$	GATE A	DIGITAL OUTPUT	$I_{\text{AGC}}$
0	0	output < 255	0 $\mu\text{A}$
		output > 255	+500 $\mu\text{A}$
0	1	output < 0	+7.5 $\mu\text{A}$
		0 < output < 255	-7.5 $\mu\text{A}$
		output > 255	+500 $\mu\text{A}$
1	0	X <sup>(1)</sup>	0 $\mu\text{A}$
1	1	output < 0	+7.5 $\mu\text{A}$
		0 < output < 255	-7.5 $\mu\text{A}$

**Note**

- X = don't care.

**Table 3** CLAMP output current.

CLAMP	GATE B	DIGITAL OUTPUT	$I_{\text{CLAMP}}$
C	1	output < 128	+50 $\mu\text{A}$
		output > 128	-50 $\mu\text{A}$
X <sup>(1)</sup>	0	X <sup>(1)</sup>	0 $\mu\text{A}$
Y	1	output < 64	+50 $\mu\text{A}$
		64 < output	-50 $\mu\text{A}$

**Note**

- X = don't care.

**Table 5** Output coding and input voltage (typical values).

STEP	$V_i$	BINARY OUTPUTS								TWO'S COMPLEMENT							
		D7	D6	D5	D4	D3	D2	D1	D0	D7	D6	D5	D4	D3	D2	D1	D0
Underflow	-	0	0	0	0	0	0	0	0	1	0	0	0	0	0	0	0
0	2.6	0	0	0	0	0	0	0	0	1	0	0	0	0	0	0	0
1	-	0	0	0	0	0	0	0	1	1	0	0	0	0	0	0	1
.	-	.	.	.	.	.	.	.	.	.	.	.	.	.	.	.	.
.	-	.	.	.	.	.	.	.	.	.	.	.	.	.	.	.	.
254	-	1	1	1	1	1	1	1	0	0	1	1	1	1	1	1	0
255	3.6	1	1	1	1	1	1	1	1	0	1	1	1	1	1	1	1
Overflow	-	1	1	1	1	1	1	1	1	0	1	1	1	1	1	1	1

**Table 4** OFY and OFC input coding.

OFY (OR OFC)	Y0 TO Y7 (OR C0 TO C7)
0	active, two's complement
1	high impedance
open circuit <sup>(1)</sup>	active, binary

**Note**

- Use C  $\geq$  10 pF to DGND.

# YC 8-bit low-power analog-to-digital video interface

TDA8758

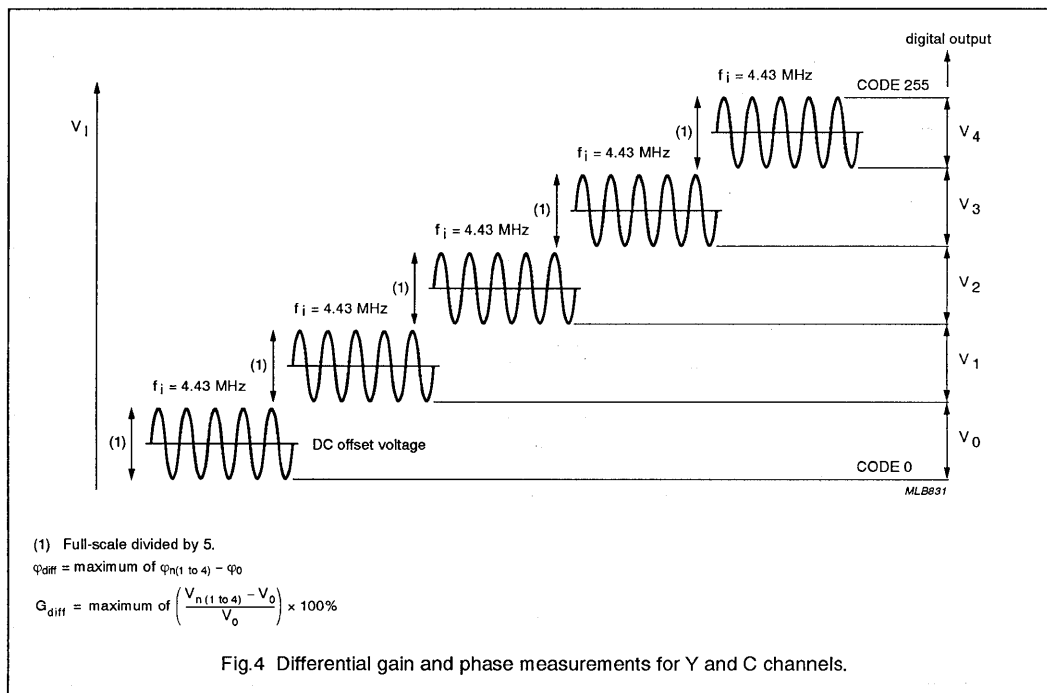

Fig.4 Differential gain and phase measurements for Y and C channels.

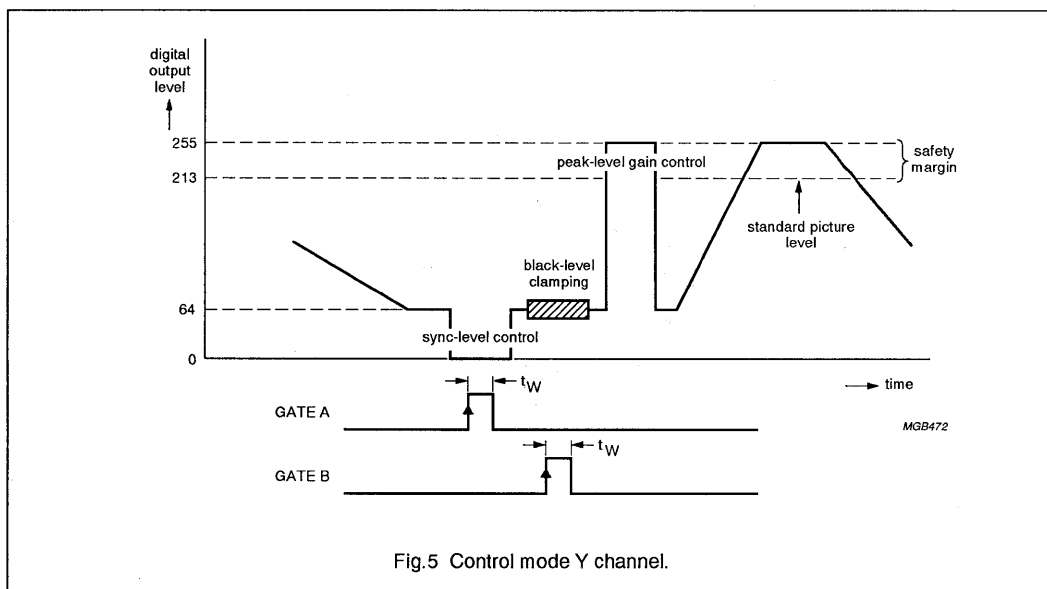

Fig.5 Control mode Y channel.

YC 8-bit low-power analog-to-digital video interface

TDA8758

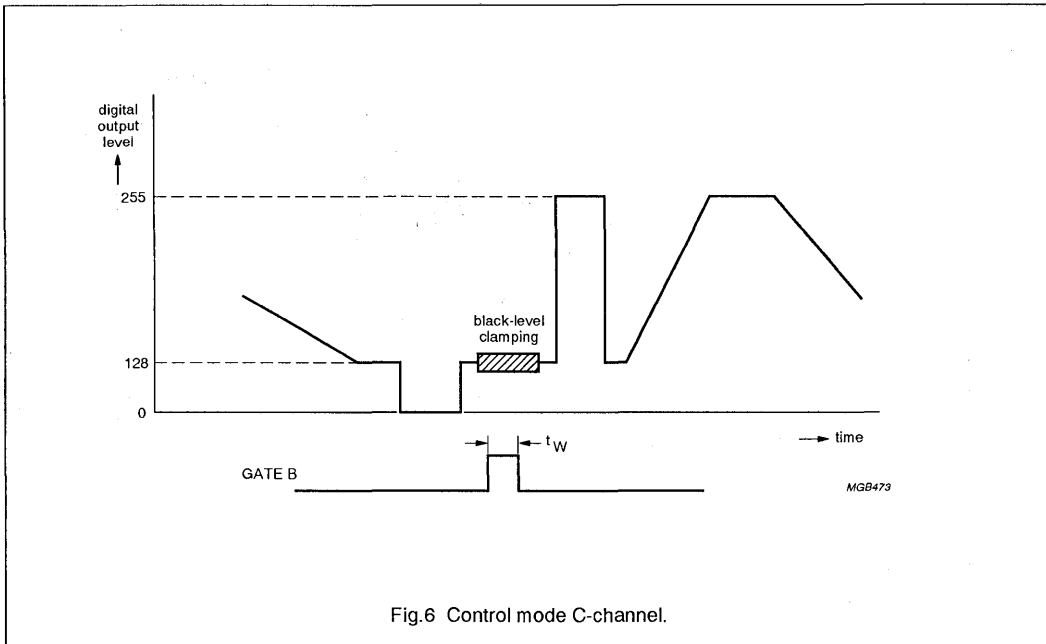

Fig.6 Control mode C-channel.

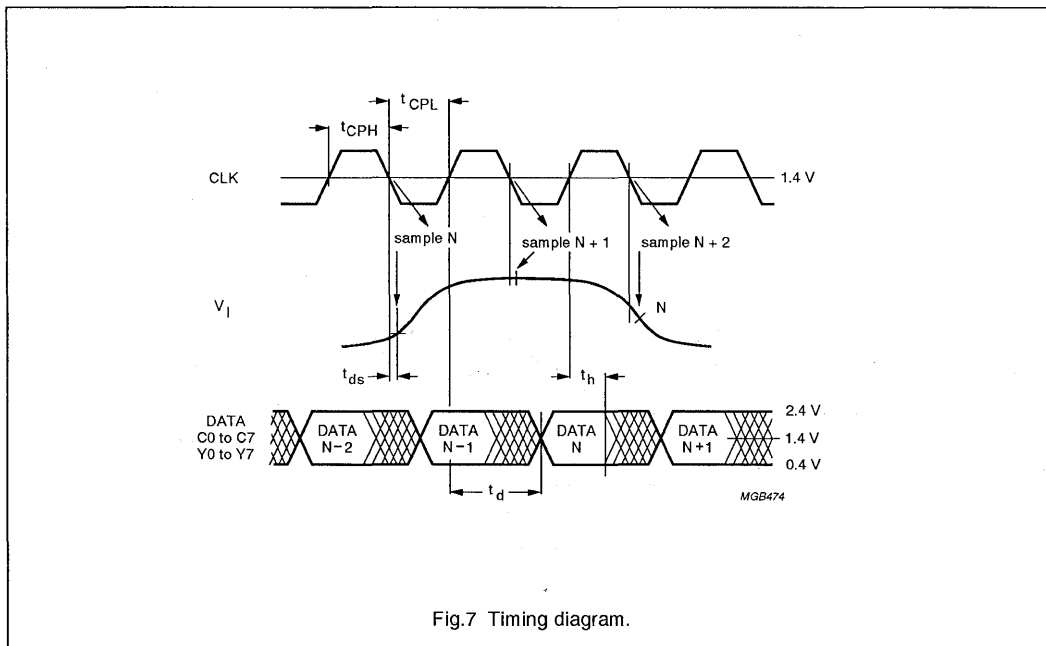

Fig.7 Timing diagram.

YC 8-bit low-power analog-to-digital video interface

TDA8758

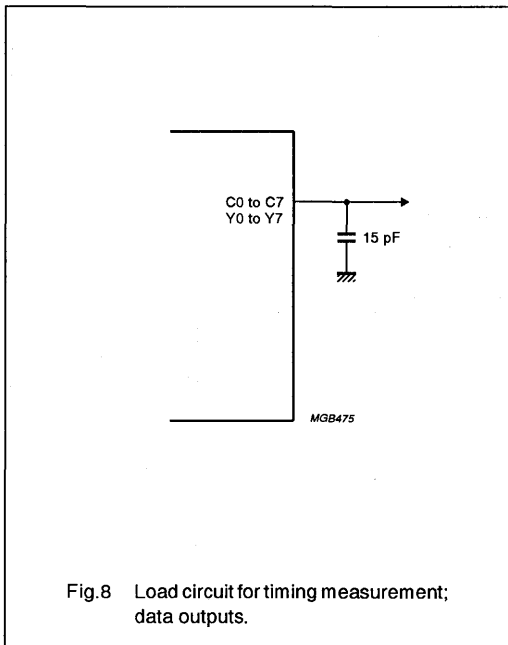

Fig.8 Load circuit for timing measurement; data outputs.

YC 8-bit low-power analog-to-digital video interface

TDA8758

APPLICATION INFORMATION

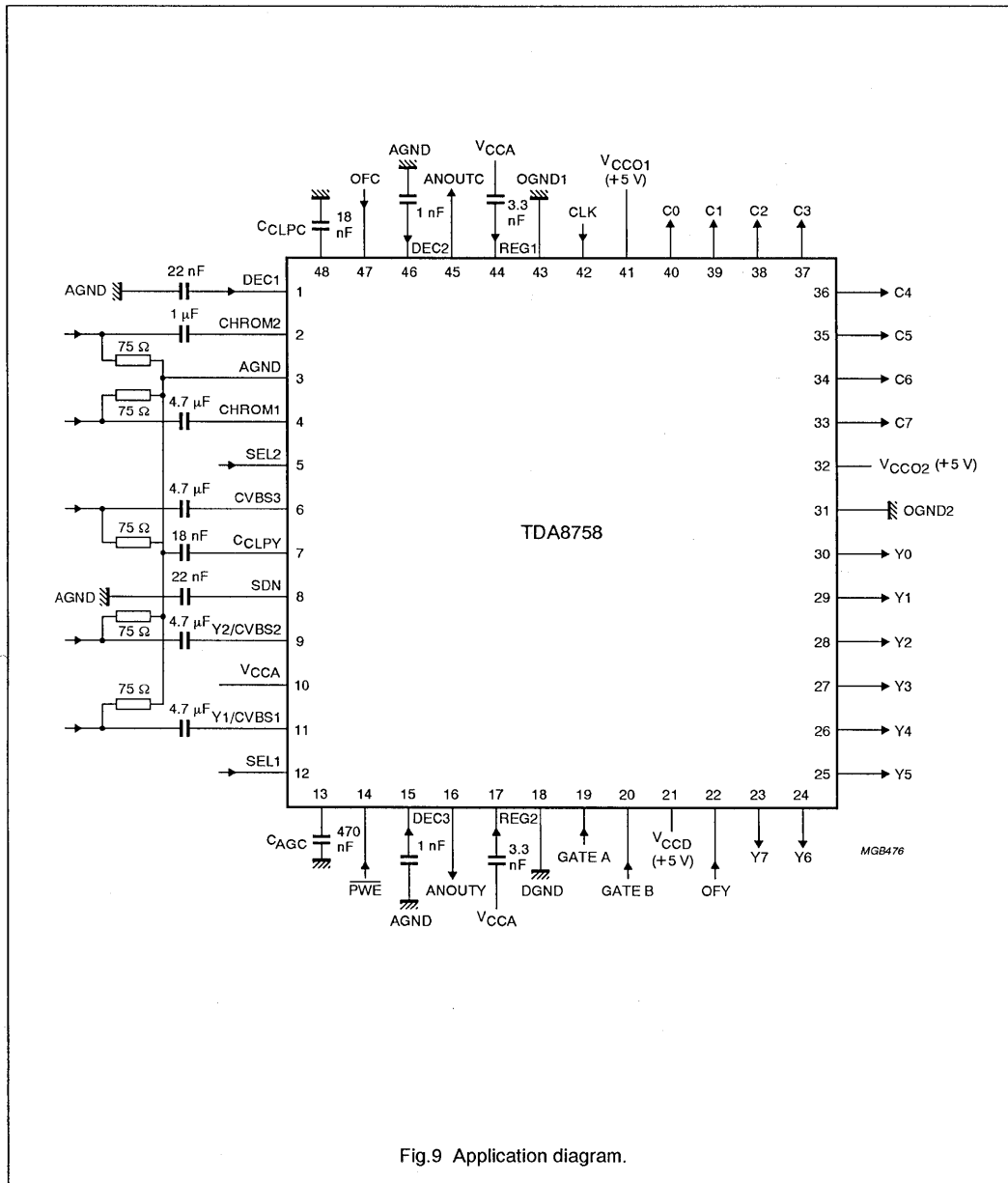

Fig.9 Application diagram.

## 10-bit high-speed analog-to-digital converter

**TDA8760**

### FEATURES

- 10-bit resolution
- Sampling rate up to 50 MHz
- Total harmonic distortion (THD): -65 dB at 4.43 MHz full scale and a 40 MHz clock frequency
- High signal-to-noise ratio over a large analog input frequency range (8.8 effective bits at 10 MHz full-scale input at a 40 MHz clock frequency)
- +5 V power supplies
- Binary or two's complement 3-state TTL outputs
- In-range 3-state TTL output
- TTL compatible digital inputs
- LOW-level AC clock input signal allowed
- Power dissipation 850 mW (typical)
- Low analog input capacitance (typ. 4.5 pF), no buffer amplifier required
- No external sample-and-hold circuit required
- Analog Input; single or differential
- External amplitude range control
- Voltage controlled regulator included.

### APPLICATIONS

- High-speed analog-to-digital conversion for
  - Video signal digitizing
  - High Definition TV (HDTV)
  - Digital video broadcasting (satellite and cable)
  - Transient signal analysis
  - High energy physics research
  - Sigma-delta (SD) modulators
  - Medical imaging
  - Radar pulse digitizing.

### GENERAL DESCRIPTION

The TDA8760 is a monolithic bipolar 10-bit analog-to-digital converter (ADC) for video or other applications. It converts the analog input signal into 10-bit binary coded digital words at a maximum sampling rate of 50 MHz. All digital inputs and outputs are TTL compatible. However, a sine-wave clock input signal is allowed.

# 10-bit high-speed analog-to-digital converter

TDA8760

## QUICK REFERENCE DATA

SYMBOL	PARAMETER	CONDITIONS	MIN.	TYP.	MAX.	UNIT
V <sub>CCA</sub>	analog supply voltage		4.75	5.0	5.25	V
V <sub>CCD</sub>	digital supply voltage		4.75	5.0	5.25	V
V <sub>CCO</sub>	output supply voltage		4.75	5.0	5.25	V
I <sub>CCA</sub>	analog supply current		–	95	100	mA
I <sub>CCD</sub>	digital supply current		–	40	45	mA
I <sub>CCO</sub>	output supply current		–	35	40	mA
ILE	DC integral linearity error	f <sub>clk</sub> = 4 MHz	–	±1.0	±2.0	LSB
DLE	DC differential linearity error	f <sub>clk</sub> = 4 MHz	–	±0.6	±1.0	LSB
AILE	AC integral linearity error	f <sub>clk</sub> = 40 MHz; f <sub>i</sub> = 4.43 MHz	–	±1.2	±2.0	LSB
f <sub>clk(max)</sub>	maximum clock frequency					
	TDA8760K/2		20	–	–	MHz
	TDA8760K/4		40	–	–	MHz
	TDA8760K/5		50	–	–	MHz
P <sub>tot</sub>	total power dissipation		–	850	970	mW
T <sub>amb</sub>	operating ambient temperature		0	–	+70	°C

## ORDERING INFORMATION

EXTENDED TYPE NUMBER	PACKAGE				
	PINS	PIN POSITION	MATERIAL	CODE	SAMPLING FREQUENCY (MHz)
TDA8760K/2	44	PLCC	plastic	SOT187	20
TDA8760K/4	44	PLCC	plastic	SOT187	40
TDA8760K/5	44	PLCC	plastic	SOT187	50



10-bit high-speed analog-to-digital converter

TDA8760

BLOCK DIAGRAM

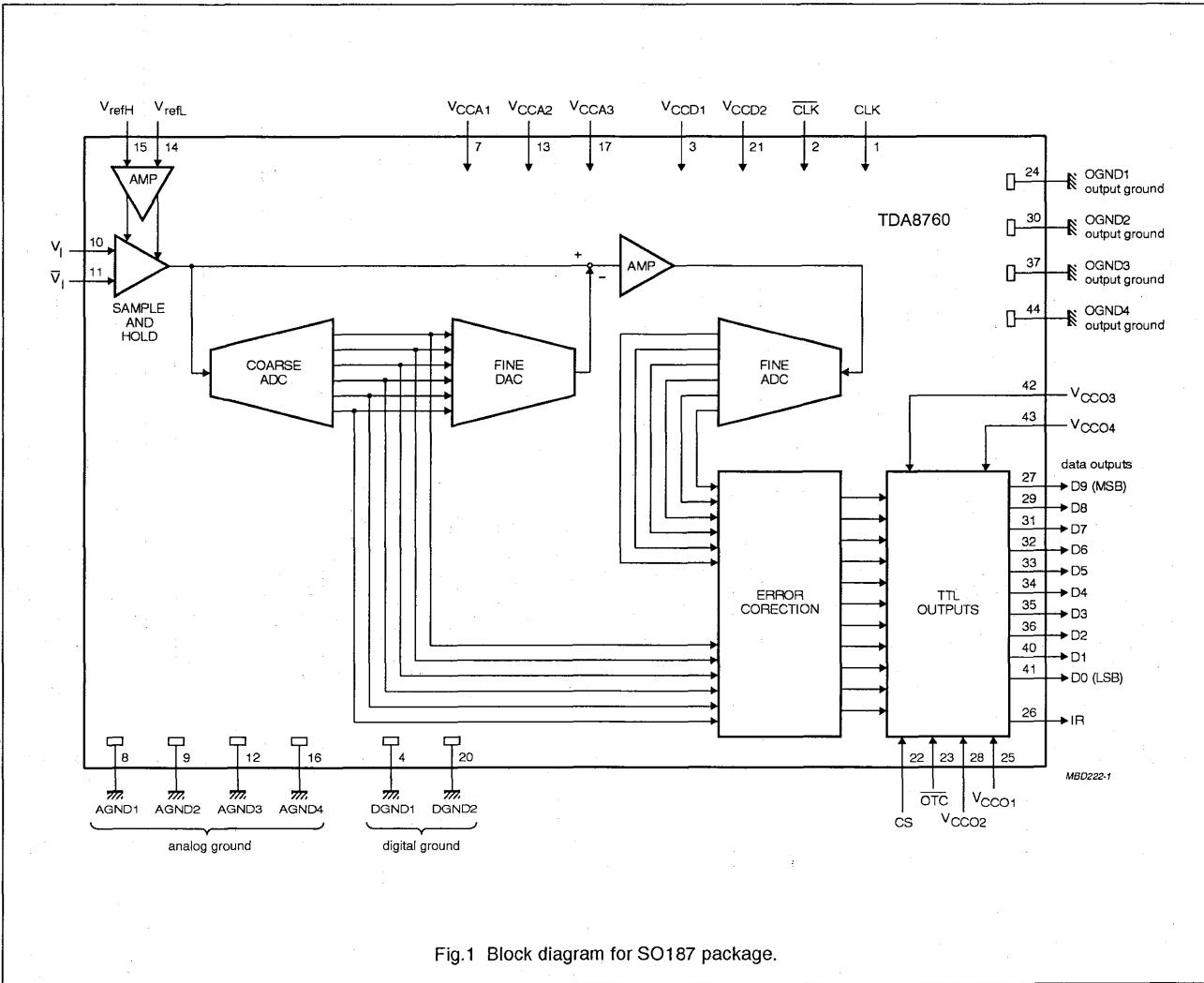

Fig.1 Block diagram for SO187 package.

# 10-bit high-speed analog-to-digital converter

TDA8760

## PINNING

SYMBOL	PIN	DESCRIPTION
CLK	1	clock input
CLK	2	complementary clock input
V <sub>CCD1</sub>	3	digital supply voltage (+5 V)
DGND1	4	digital ground
n.c.	5	not connected
n.c.	6	not connected
V <sub>CCA1</sub>	7	analog supply voltage (+5 V)
AGND1	8	analog ground
AGND2	9	analog ground
V <sub>I</sub>	10	analog input voltage
$\bar{V}_I$	11	complementary analog input voltage
AGND3	12	analog ground
V <sub>CCA2</sub>	13	analog supply voltage (+5 V)
V <sub>refL</sub>	14	reference voltage LOW
V <sub>refH</sub>	15	reference voltage HIGH
AGND4	16	analog ground
V <sub>CCA3</sub>	17	analog supply voltage (+5 V)
n.c.	18	not connected
n.c.	19	not connected
DGND2	20	digital ground
V <sub>CCD2</sub>	21	digital supply voltage (+5 V)
CS	22	chip select input (TTL level input; active HIGH)
OTC	23	output two's complement
OGND1	24	output ground
V <sub>CCO1</sub>	25	output supply voltage (+5 V)
IR	26	in-range output
D9	27	data output, bit 9 (MSB)
V <sub>CCO2</sub>	28	output supply voltage (+5 V)
D8	29	data output, bit 8
OGND2	30	output ground
D7	31	data output, bit 7
D6	32	data output, bit 6
D5	33	data output, bit 5
D4	34	data output, bit 4
D3	35	data output, bit 3
D2	36	data output, bit 2
OGND3	37	output ground
n.c.	38	not connected
n.c.	39	not connected
D1	40	data output, bit 1

# 10-bit high-speed analog-to-digital converter

## TDA8760

SYMBOL	PIN	DESCRIPTION
D0	41	data output, bit 0 (LSB)
V <sub>CC03</sub>	42	output supply voltage (+5 V)
V <sub>CC04</sub>	43	output supply voltage (+5 V)
OGND4	44	output ground

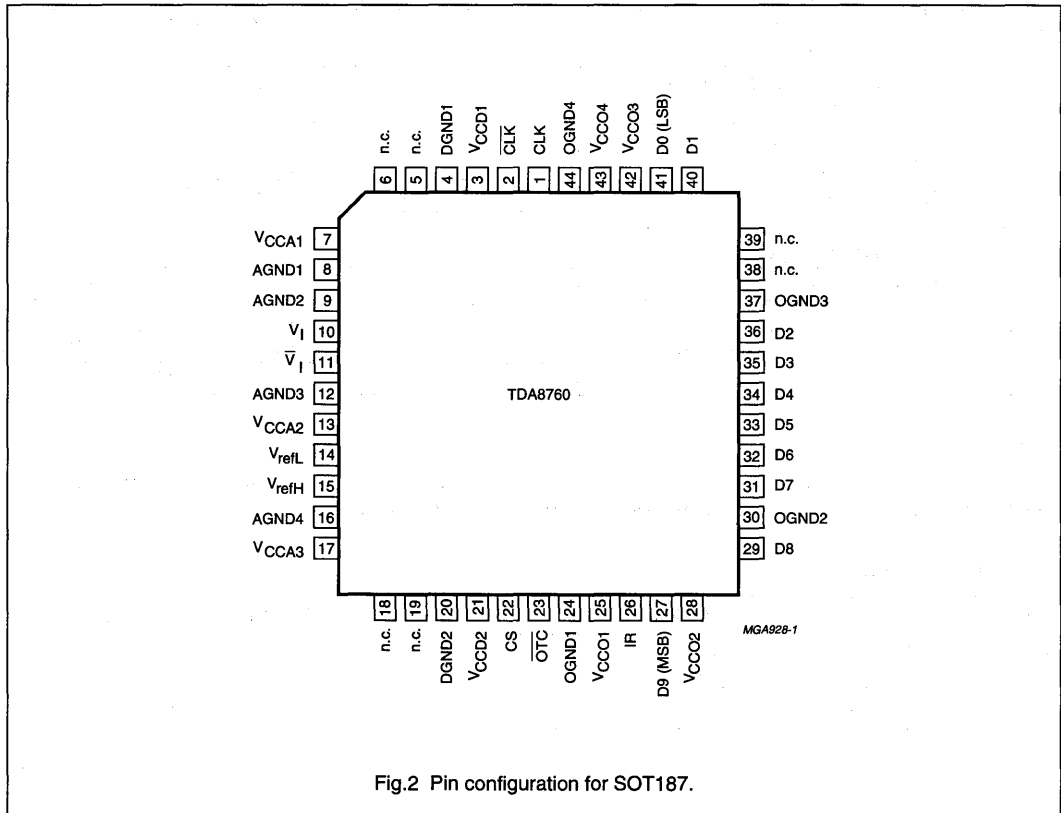

Fig.2 Pin configuration for SOT187.

# 10-bit high-speed analog-to-digital converter

TDA8760

## LIMITING VALUES

In accordance with the Absolute Maximum Rating System (IEC 134).

SYMBOL	PARAMETER	CONDITIONS	MIN.	MAX.	UNIT
$V_{CCA}$	analog supply voltage		-0.3	+7.0	V
$V_{CCD}$	digital supply voltage		-0.3	+7.0	V
$V_{CCO}$	output supply voltage		-0.3	+7.0	V
$\Delta V_{CC1}$	supply voltage difference between $V_{CCA}$ and $V_{CCD}$		-0.5	+0.5	V
$\Delta V_{CC2}$	supply voltage difference between $V_{CCO}$ and $V_{CCD}$		-0.5	+0.5	V
$\Delta V_{CC3}$	supply voltage difference between $V_{CCA}$ and $V_{CCO}$		-0.5	0.5	V
$V_I$	input voltage	referenced to AGND	0.3	$V_{CCA}$	V
$V_{I(p-p)}$	input voltage for differential clock drive (peak-to-peak value)		-	$V_{CCD}$	V
$I_O$	output current		-	10	mA
$T_{stg}$	storage temperature		-55	+150	°C
$T_{amb}$	operating ambient temperature		0	+70	°C
$T_j$	junction temperature		-	+150	°C

## HANDLING

Inputs and outputs are protected against electrostatic discharges in normal handling. However, to be totally safe, it is desirable to take normal precautions appropriate to handling integrated circuits.

## THERMAL RESISTANCE

SYMBOL	PARAMETER	THERMAL RESISTANCE
$R_{th\ j-a}$	from junction to ambient in free air	
	TDA8760K/5; TDA8760K/4	35 K/W
	TDA8760K/2	46 K/W

# 10-bit high-speed analog-to-digital converter

TDA8760

## CHARACTERISTICS

$V_{CCA} = V_{CCD} = V_{CCO} = 4.75$  to  $5.25$  V; AGND and DGND shorted together;

$V_{CCA} - V_{CCD} = V_{CCO} - V_{CCD} = V_{CCA} - V_{CCO} = -0.25$  to  $+0.25$  V;  $T_{amb} = 0$  to  $+70$  °C; unless otherwise specified.

Typical values measured at  $V_{CCA} = V_{CCD} = V_{CCO} = 5$  V;  $T_{amb} = 25$  °C.

SYMBOL	PARAMETER	CONDITIONS	MIN.	TYP.	MAX.	UNIT
<b>Supply</b>						
$V_{CCA}$	analog supply voltage		4.75	5.0	5.25	V
$V_{CCD}$	digital supply voltage		4.75	5.0	5.25	V
$V_{CCO}$	output supply voltage		4.75	5.0	5.25	V
$I_{CCA}$	analog supply current		–	95	100	mA
$I_{CCD}$	digital supply current		–	40	45	mA
$I_{CCO}$	output supply current	all outputs LOW	–	35	40	mA
<b>Inputs</b>						
CLK and $\overline{\text{CLK}}$ (REFERENCED TO DGND); NOTE 1						
$V_{IL}$	LOW level input voltage		0	–	0.8	V
$V_{IH}$	HIGH level input voltage		2.0	–	$V_{CCD}$	V
$I_{IL}$	LOW level input current	$V_{\text{clk}}$ or $V_{\overline{\text{clk}}} = 0.4$ V	–400	–	–	mA
$I_{IH}$	HIGH level input current	$V_{\text{clk}}$ or $V_{\overline{\text{clk}}} = 2.0$ V	–	–	100	mA
		$V_{\text{clk}}$ or $V_{\overline{\text{clk}}} = V_{CCD}$	–	–	300	mA
$Z_i$	input impedance	$f_{\text{clk}} = 40$ MHz	–	2	–	k $\Omega$
$C_i$	input capacitance	$f_{\text{clk}} = 40$ MHz	–	4.5	–	pF
$\Delta V_{\text{clk}}$	AC input voltage for switching ( $V_{\text{clk}} - V_{\overline{\text{clk}}}$ )	DC level = 1.5 V	0.5	–	2.0	V
		DC level = 2.5 V	1.5	–	5.0	V
<b>OTC AND CS (REFERENCED TO DGND); SEE TABLE 3</b>						
$V_{IL}$	LOW level input voltage		0	–	0.8	V
$V_{IH}$	HIGH level input voltage		2.0	–	$V_{CCD}$	V
$I_{IL}$	LOW level input current	$V_{IL} = 0.8$ V	–400	–	–	$\mu$ A
$I_{IH}$	HIGH level input current	$V_{IH} = 2.0$ V	–	–	20	$\mu$ A

# 10-bit high-speed analog-to-digital converter

TDA8760

SYMBOL	PARAMETER	CONDITIONS	MIN.	TYP.	MAX.	UNIT
<b><math>V_I</math> AND <math>\bar{V}_I</math> (REFERENCED TO AGND; SEE ALSO TABLES 1 AND 2)</b>						
$I_{IL}$	LOW level input current	$V_{refH} - V_{refL} = 1.5 \text{ V}$	–	7	–	$\mu\text{A}$
$I_{IH}$	HIGH level input current	$V_{refH} - V_{refL} = 1.5 \text{ V}$	–	22	–	$\mu\text{A}$
$Z_I$	input impedance	$f_i = 4.43 \text{ MHz}$	–	2	–	$\text{k}\Omega$
$C_I$	input capacitance	$f_i = 4.43 \text{ MHz}$	–	4.5	–	$\text{pF}$
$V_{\text{offset(d)}}$	input offset voltage	differential mode; $V_I = \bar{V}_I$ ; output code 511; Table 1  $V_{CCA} = 5 \text{ V}$ $V_{CCA} = 4.75 \text{ V}$ $V_{CCA} = 5.25 \text{ V}$	3.3 3.2 3.3	3.4 – –	3.6 3.45 3.8	V V V
$V_{\text{offset(s)}}$	input offset voltage	single mode; $V_I = V_{\text{offset(s)}}$ ; output code 511; Table 2  $V_{CCA} = 5 \text{ V}$ $V_{CCA} = 4.75 \text{ V}$ $V_{CCA} = 5.25 \text{ V}$	3.6 tbf tbf	3.7 – –	3.8 tbf tbf	V V V
<b>Voltage controlled regulator inputs <math>V_{refH}</math> and <math>V_{refL}</math> (referenced to AGND); differential input</b>						
$V_{refH}$	reference voltage HIGH		4.0	4.5	$V_{CCA}$	V
$V_{refL}$	reference voltage LOW		2.5	3.0	3.5	V
$V_{I(p-p)}$	input voltage amplitude (peak-to-peak value)		1.4	1.5	1.6	V
$I_{refH}$	input current at $V_{refH}$		–	10	–	$\mu\text{A}$
$I_{refL}$	input current at $V_{refL}$		–	10	–	$\mu\text{A}$
<b>Voltage controlled regulator inputs <math>V_{refH}</math> and <math>V_{refL}</math> (referenced to AGND); single input</b>						
$V_{refH}$	reference voltage HIGH		4.0	4.4	$V_{CCA}$	V
$V_{refL}$	reference voltage LOW		2.5	3.0	3.5	V
$V_{I(p-p)}$	input voltage amplitude (peak-to-peak value)		1.3	1.4	1.5	V
$I_{refH}$	input current at $V_{refH}$		–	10	–	$\mu\text{A}$
$I_{refL}$	input current at $V_{refL}$		–	10	–	$\mu\text{A}$
<b>Outputs (referenced to DGND)</b>						
DIGITAL OUTPUTS D9 TO D0 AND IR (REFERENCED TO DGND)						
$V_{OL}$	LOW level output voltage	$I_O = 2 \text{ mA}$	0	–	0.4	V
$V_{OH}$	HIGH level output voltage	$I_O = -0.4 \text{ mA}$	2.4	–	$V_{CCD}$	V
$I_O$	output current in 3-state mode	$0.4 \text{ V} < V_O < V_{CCO}$	–20	–	+20	$\mu\text{A}$

# 10-bit high-speed analog-to-digital converter

TDA8760

SYMBOL	PARAMETER	CONDITIONS	MIN.	TYP.	MAX.	UNIT
<b>Switching characteristics</b>						
CLOCK FREQUENCY $f_{clk}$ (NOTE 1; SEE FIG.3)						
$f_{clk(min)}$	minimum clock frequency		–	–	1	MHz
$f_{clk(max)}$	maximum clock frequency					
	TDA8760K/5		50	–	–	MHz
	TDA8760K/4		40	–	–	MHz
	TDA8760K/2		20	–	–	MHz
$t_{CPH}$	clock pulse width HIGH	note 7	10	–	–	ns
$t_{CPL}$	clock pulse width LOW		8	–	–	ns
<b>Analog signal processing in differential input mode; see Table 1; 50% clock duty factor;</b> $V_{I(p-p)} = V_{refH} - V_{refL} = 1.5 V$						
LINEARITY						
ILE	DC integral linearity error	$f_{clk} = 4 MHz$	–	$\pm 1.0$	$\pm 2.0$	LSB
DLE	DC differential linearity error	$f_{clk} = 4 MHz$	–	$\pm 0.6$	$\pm 1.0$	LSB
AILE	AC integral linearity error	note 3	–	$\pm 1.2$	$\pm 2.0$	LSB
BANDWIDTH ( $f_{clk} = 50 MHz$ ); NOTE 9						
B	Analog bandwidth	-1 dB	–	140	–	MHz
		-3 dB	–	220	–	MHz
HARMONICS ( $f_{clk} = 40 MHz$ ); SEE FIGS 6, 8, 9 AND 10						
$f_1$	fundamental harmonics (full scale)	$f_i = 4.43 MHz$	–	–	0	dB
$f_{all}$	harmonics (full scale); all components	$f_i = 4.43 MHz$				
	second harmonics		–	-70	-63	dB
	third harmonics		–	-70	-63	dB
$THD_d$	total harmonic distortion	$f_i = 4.43 MHz$ ; note 2	–	-65	-60	dB
SIGNAL-TO-NOISE RATIO; NOTES 4 AND 5; SEE FIGS 6, 8, 9 AND 10						
SNR	signal-to-noise ratio	without harmonics; $f_{clk} = 40 MHz$ ; $f_i = 4.43 MHz$	54	56	–	dB
EFFECTIVE BITS; NOTES 4 AND 5; SEE FIGS 6, 8, 9 AND 10						
EB	effective bits TDA8760K/2 ( $f_{clk} = 20 MHz$ )	$f_i = 4.43 MHz$	–	8.90	–	bits
		$f_i = 7.5 MHz$	–	8.70	–	bits
	effective bits TDA8760K/4 ( $f_{clk} = 40 MHz$ )	$f_i = 4.43 MHz$	–	8.80	–	bits
		$f_i = 10 MHz$	–	8.80	–	bits
		$f_i = 15 MHz$	–	8.70	–	bits
	effective bits TDA8760K/5 ( $f_{clk} = 50 MHz$ )	$f_i = 4.43 MHz$	–	8.70	–	bits
		$f_i = 10 MHz$	–	8.65	–	bits
		$f_i = 15 MHz$	–	8.60	–	bits
		$f_i = 20 MHz$	–	8.20	–	bits

# 10-bit high-speed analog-to-digital converter

TDA8760

SYMBOL	PARAMETER	CONDITIONS	MIN.	TYP.	MAX.	UNIT
<b>TWO-TONE</b>						
Two-tone	two-tone intermodulation rejection	$f_{\text{clk}} = 40 \text{ MHz}$ ; note 8	–	–65	–	dB
<b>BIT ERROR RATE</b>						
BER	bit error rate	$f_{\text{clk}} = 40 \text{ MHz}$ ; $f_i = 4.43 \text{ MHz}$ ; $V_i = \pm 16 \text{ LSB}$ at code 512	–	$2 \times 10^{-12}$	–	times/ samples
<b>DIFFERENTIAL GAIN; SEE FIG.5</b>						
$G_{\text{diff}}$	differential gain	$f_{\text{clk}} = 20 \text{ MHz}$ ; $f_i = 4.43 \text{ MHz}$	–	0.5	tbf	%
		$f_{\text{clk}} = 40 \text{ MHz}$ ; $f_i = 4.43 \text{ MHz}$	–	1.0	tbf	%
<b>DIFFERENTIAL PHASE</b>						
$\Phi_{\text{diff}}$	differential phase	$f_{\text{clk}} = 40 \text{ MHz}$ ; $f_i = 4.43 \text{ MHz}$	–	0.1	0.2	deg
<b>Analog signal processing in single input mode; see Table 2; 50% clock duty factor; <math>V_{i(p-p)} = V_{\text{refH}} - V_{\text{refL}} = 1.4 \text{ V}</math></b>						
<b>LINEARITY</b>						
ILE	DC integral linearity error	$f_{\text{clk}} = 4 \text{ MHz}$	–	$\pm 1.0$	$\pm 2.0$	LSB
DLE	DC differential linearity error	$f_{\text{clk}} = 4 \text{ MHz}$	–	$\pm 0.6$	$\pm 1.0$	LSB
AILE	AC integral linearity error	note 3	–	$\pm 1.2$	$\pm 2.0$	LSB
<b>BANDWIDTH (<math>f_{\text{clk}} = 50 \text{ MHz}</math>); NOTE 9</b>						
B	Analog bandwidth	–1 dB	–	140	–	MHz
		–3 dB	–	220	–	MHz
<b>HARMONICS (<math>f_{\text{clk}} = 40 \text{ MHz}</math>); SEE FIG.7</b>						
$f_1$	fundamental harmonics (full scale)	$f_i = 4.43 \text{ MHz}$	–	–	0	dB
$f_{\text{all}}$	harmonics (full scale); all components	$f_i = 4.43 \text{ MHz}$	–	–	–	–
	second harmonics		–	–61	–	dB
	third harmonics		–	–62	–	dB
THD <sub>s</sub>	total harmonic distortion	$f_i = 4.43 \text{ MHz}$ ; note 2	–	–59	–	dB
<b>SIGNAL-TO-NOISE RATIO; NOTES 4 AND 5; SEE FIG.7</b>						
SNR	signal-to-noise ratio	without harmonics; $f_{\text{clk}} = 40 \text{ MHz}$ ; $f_i = 4.43 \text{ MHz}$	54	56	–	dB



# 10-bit high-speed analog-to-digital converter

TDA8760

SYMBOL	PARAMETER	CONDITIONS	MIN.	TYP.	MAX.	UNIT
EFFECTIVE BITS; NOTES 4 AND 5; SEE FIG.7						
EB	effective bits TDA8760K/2 ( $f_{\text{clk}} = 20 \text{ MHz}$ )	$f_i = 4.43 \text{ MHz}$	–	8.70	–	bits
		$f_i = 7.5 \text{ MHz}$	–	8.50	–	bits
	effective bits TDA8760K/4 ( $f_{\text{clk}} = 40 \text{ MHz}$ )	$f_i = 4.43 \text{ MHz}$	–	8.50	–	bits
		$f_i = 10 \text{ MHz}$	–	8.20	–	bits
	effective bits TDA8760K/5 ( $f_{\text{clk}} = 50 \text{ MHz}$ )	$f_i = 4.43 \text{ MHz}$	–	8.25	–	bits
		$f_i = 10 \text{ MHz}$	–	8.00	–	bits
TWO-TONE						
Two-tone	two-tone intermodulation rejection	$f_{\text{clk}} = 40 \text{ MHz}$ ; note 8	–	–60	–	dB
BIT ERROR RATE						
BER	bit error rate	$f_{\text{clk}} = 40 \text{ MHz}$ ; $f_i = 4.43 \text{ MHz}$ ; $V_i = \pm 16 \text{ LSB at code 512}$	–	$2 \times 10^{-12}$	–	times/ samples
DIFFERENTIAL GAIN; SEE FIG.5						
$G_{\text{diff}}$	differential gain	$f_{\text{clk}} = 20 \text{ MHz}$ ; $f_i = 4.43 \text{ MHz}$	–	0.5	tbf	%
		$f_{\text{clk}} = 40 \text{ MHz}$ ; $f_i = 4.43 \text{ MHz}$	–	1.0	tbf	%
DIFFERENTIAL PHASE						
$\Phi_{\text{diff}}$	differential phase	$f_{\text{clk}} = 40 \text{ MHz}$ ; $f_i = 4.43 \text{ MHz}$	–	0.1	0.2	deg
Timing (note 6; see Fig.3; $C_L = 15 \text{ pF}$ )						
$t_{\text{ds}}$	sampling delay time		–	–	2	ns
$t_{\text{h}}$	output hold time		8	–	–	ns
$t_{\text{d}}$	output delay time		–	12	16	ns
3-state output delay times (see Fig.4)						
$t_{\text{dZH}}$	enable HIGH		–	12	16	ns
$t_{\text{dZL}}$	enable LOW		–	12	16	ns
$t_{\text{dHZ}}$	disable HIGH		–	8	12	ns
$t_{\text{dLZ}}$	disable LOW		–	16	20	ns

# 10-bit high-speed analog-to-digital converter

TDA8760

## Notes

- The circuit has two clock inputs: CLK and  $\overline{\text{CLK}}$ . There are three modes of operation:

TTL mode 1:

CLK input is at TTL level with a threshold voltage of 1.5 V and sampling is taken on the falling edge of the clock input signal. CLK decoupled to DGND via a 100 nF capacitor.

TTL mode 2:

$\overline{\text{CLK}}$  input is at TTL level with threshold voltage of 1.5 V and sampling is taken on the rising edge of the clock input signal. CLK decoupled to DGND via a 100 nF capacitor.

TTL mode3:

CLK and  $\overline{\text{CLK}}$  inputs are at differential TTL levels.

AC driving modes:

When driving the CLK input directly and with any AC signal of minimum 0.5 V (p-p) and with a DC level of 1.5 V, the sampling takes place at the falling edge of the clock signal.

When driving the  $\overline{\text{CLK}}$  input with the same signal, sampling takes place at the rising edge of the clock signal. It is recommended to decouple the CLK or CLK input to DGND via a 100 nF capacitor.

- THD (total harmonic distortion) is obtained with the addition of the first five harmonics:

$$\text{THD} = 20 \log \frac{F}{\sqrt{(2\text{nd})^2 + (3\text{rd})^2 + (4\text{th})^2 + (5\text{th})^2 + (6\text{th})^2}}$$

F being the fundamental harmonic referenced at 0 dB for a full-scale sinewave input.

- AC linearity: full-scale differential sinewave ( $f_i = 4.43$  MHz;  $f_{\text{clk}} = 40$  MHz).
- Effective bits with differential input and single input are respectively executed with full scale differential input and full scale single sinewave.
- Effective bits are obtained via a Fast Fourier Transformer (FFT) treatment taking 8K acquisition points per period. The calculation takes into account all harmonics and noise up to half of the clock frequency (NYQUIST frequency). Conversion to SNR:  $\text{SNR} = \text{EB} \times 6.02 + 1.76$  dB.
- Output data acquisition: the output data is available after the maximum delay of  $t_d$ .
- $t_{\text{CPH}}$  of 9 ns (minimum) can be applied at the penalty of 0.5 effective bit drop compared to typical values.
- Intermodulation measured relative to either tone with analog input frequencies of 4.43 MHz and 4.53 MHz. The two input signals have the same amplitude and the total amplitude of both signals provides full scale to the converter.
- The -3 dB (or -1 dB) analog bandwidth is determined by the 3 dB (or 1 dB) reduction in the reconstructed output, the input being a full-scale sine wave.

# 10-bit high-speed analog-to-digital converter

TDA8760

**Table 1** Output coding with differential inputs (typical values to AGND);  $V_{I(p-p)} = V_{refH} - V_{refL} = 1.5$  V.

CODE	$V_{I(p-p)}$	$\bar{V}_{I(p-p)}$	IR	BINARY OUTPUTS	TWO'S COMPLEMENT OUTPUTS
				D9 TO D0	D9 TO D0
underflow	<3.025	>3.775	0	0000000000	1000000000
0	3.025	3.775	1	0000000000	1000000000
1	–	–	1	0000000001	1000000001
•	–	–	•	••••••••••	••••••••••
511	3.40	3.40	1	0111111111	1111111111
•	–	–	•	••••••••••	••••••~•••••
1022	–	–	1	1111111110	0111111110
1023	3.775	3.025	1	1111111111	0111111111
overflow	>3.775	<3.025	0	1111111111	0111111111

**Table 2** Output coding with single inputs (typical values to AGND);  $V_{I(p-p)} = V_{refH} - V_{refL} = 1.4$  V;  $\bar{V}_{I(p-p)} = 3.7$  V.

CODE	$V_{I(p-p)}$	IR	BINARY OUTPUTS	TWO'S COMPLEMENT OUTPUTS
			D9 TO D0	D9 TO D0
underflow	<3.0	0	0000000000	1000000000
0	3.0	1	0000000000	1000000000
1	–	1	0000000001	1000000001
•	–	•	••••••~•••••	••••••~•••••
511	3.7	1	0111111111	1111111111
•	–	•	••••••~•••••	••••••~•••••
1022	–	1	1111111110	0111111110
1023	4.4	1	1111111111	0111111111
overflow	>4.4	0	1111111111	0111111111

**Table 3** Mode selection.

$\bar{OTC}$	CS	D0 TO D9 AND IR
1	1	binary; active
0	1	two's complement; active
X <sup>(1)</sup>	0	high impedance

**Note**

- Where: X = don't care.

# 10-bit high-speed analog-to-digital converter

TDA8760

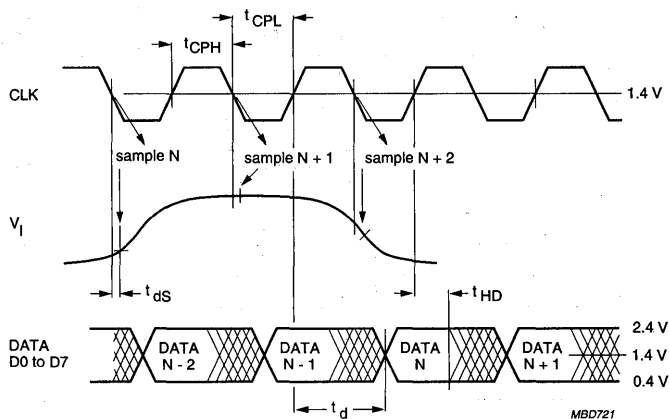
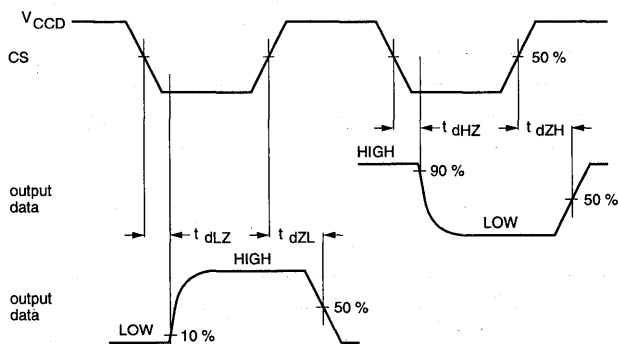
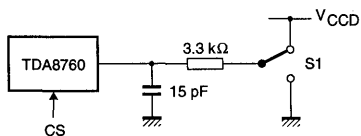

Fig.3 Timing diagram.



TEST	S1
$t_{dLZ}$	$V_{CCD}$
$t_{dZL}$	$V_{CCD}$
$t_{dHZ}$	GND
$t_{dZH}$	GND



CS = 100 kHz.

Fig.4 Timing diagram and test conditions of 3-state output delay time.

# 10-bit high-speed analog-to-digital converter

TDA8760

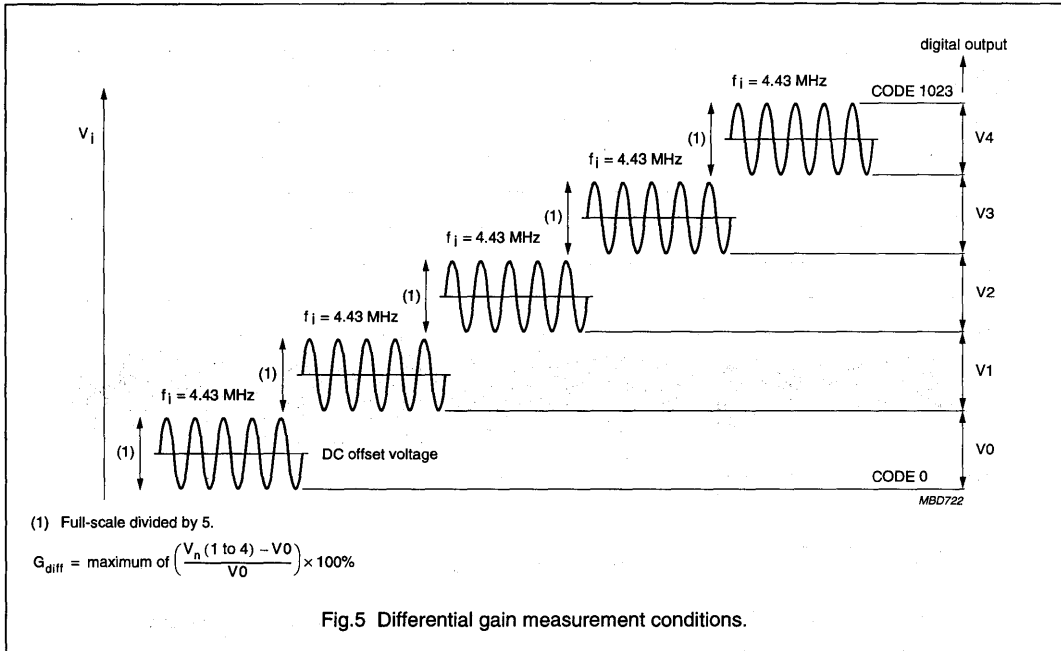

Fig.5 Differential gain measurement conditions.

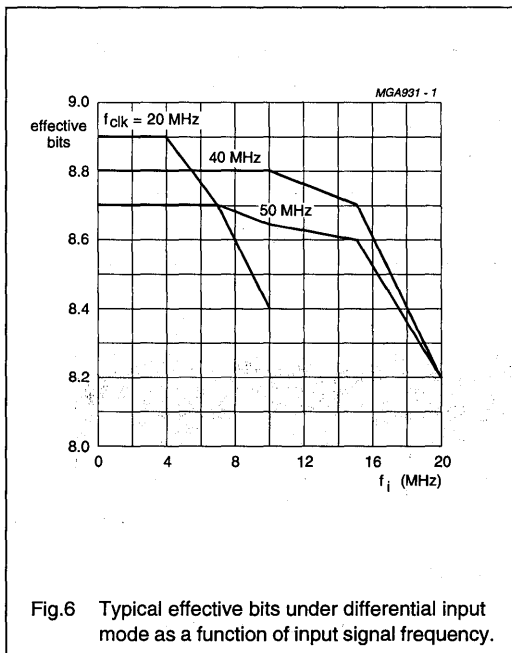

Fig.6 Typical effective bits under differential input mode as a function of input signal frequency.

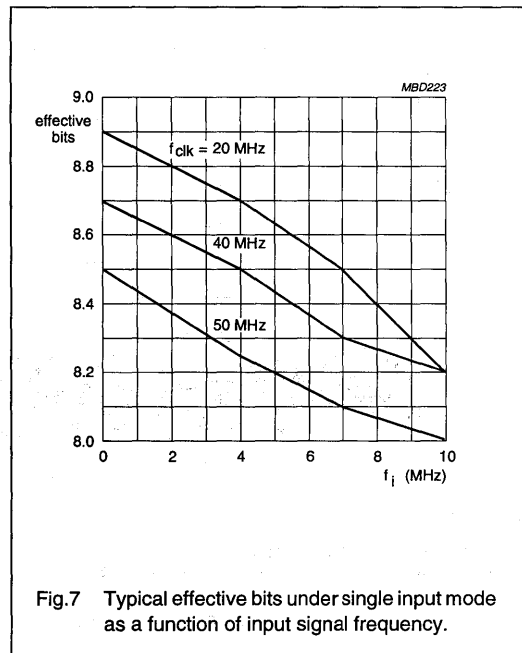
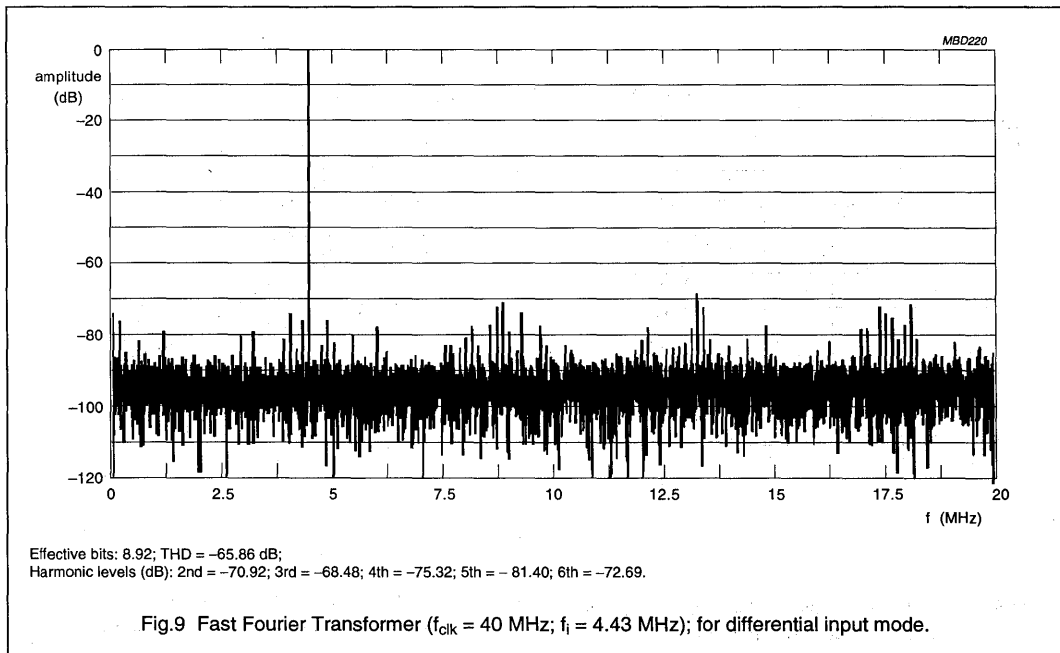
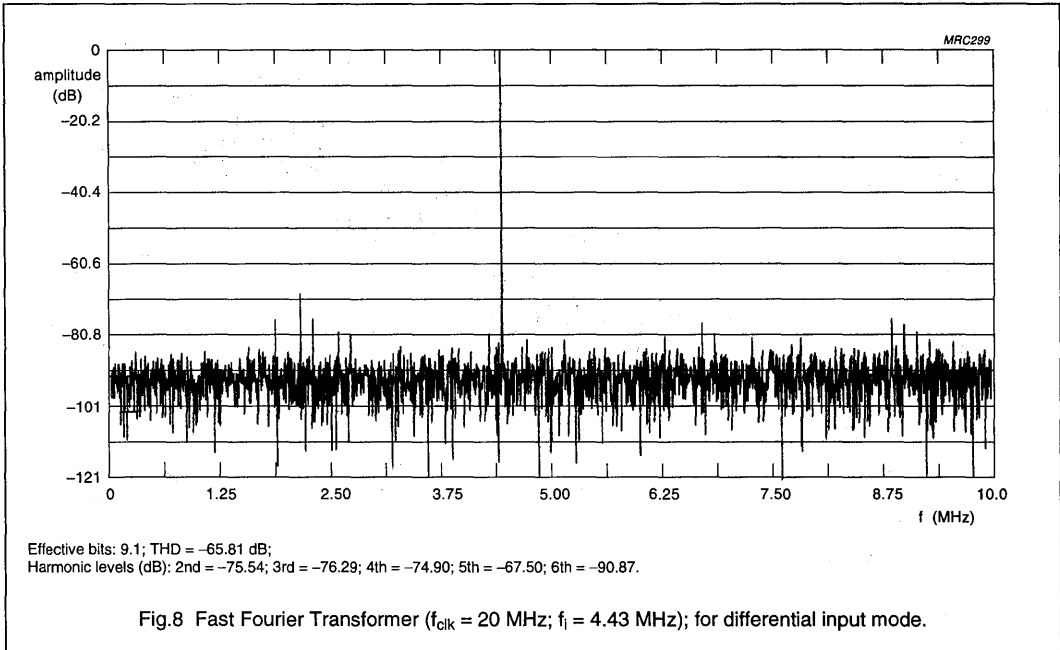

Fig.7 Typical effective bits under single input mode as a function of input signal frequency.

10-bit high-speed analog-to-digital converter

TDA8760



10-bit high-speed analog-to-digital  
converter

TDA8760

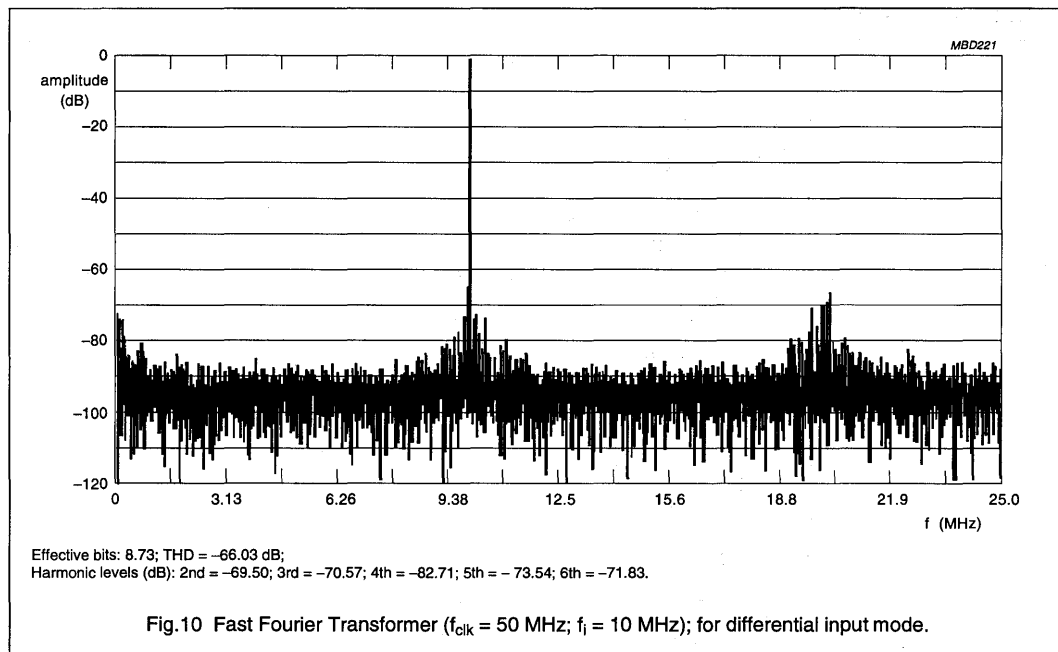

# 10-bit high-speed analog-to-digital converter

TDA8760

## INTERNAL PIN CONFIGURATION

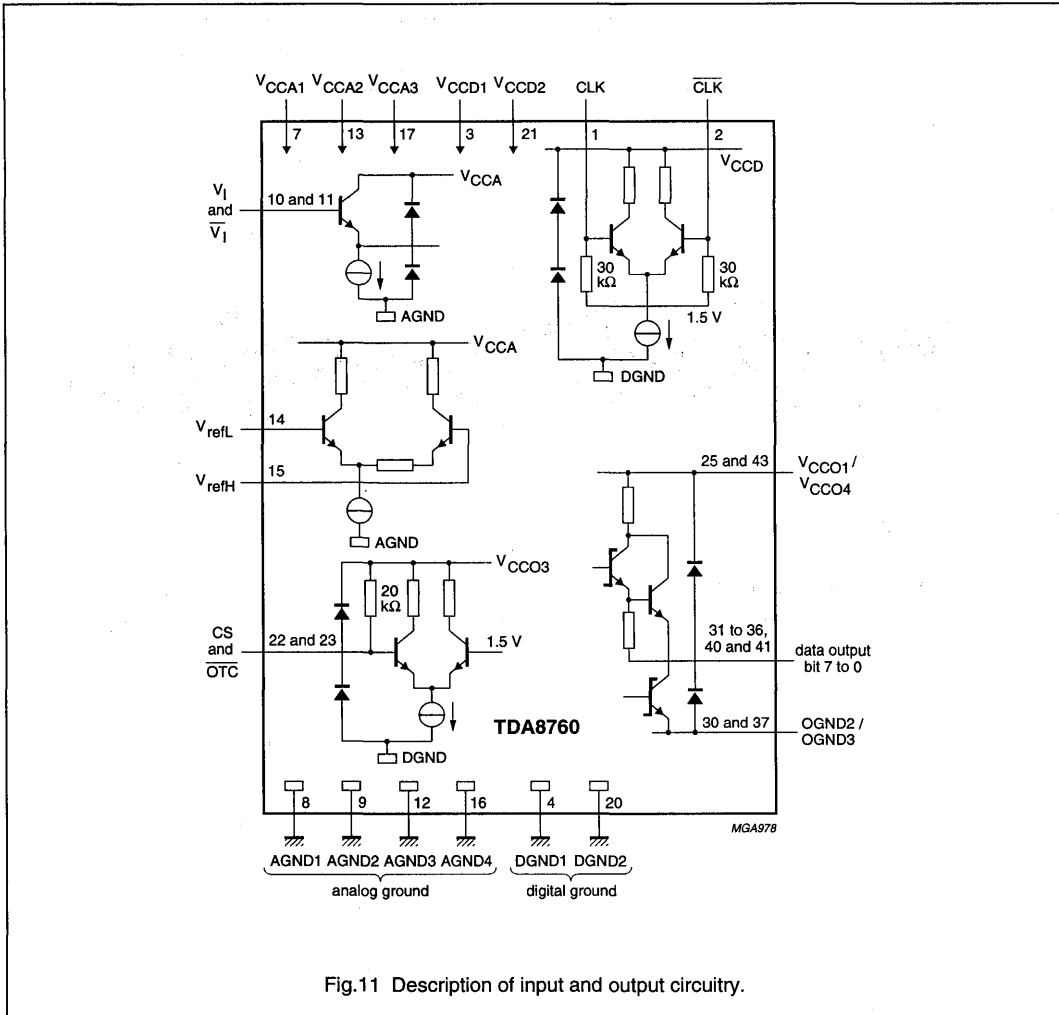

Fig.11 Description of input and output circuitry.



# 10-bit high-speed analog-to-digital converter

## TDA8760

### APPLICATION INFORMATION

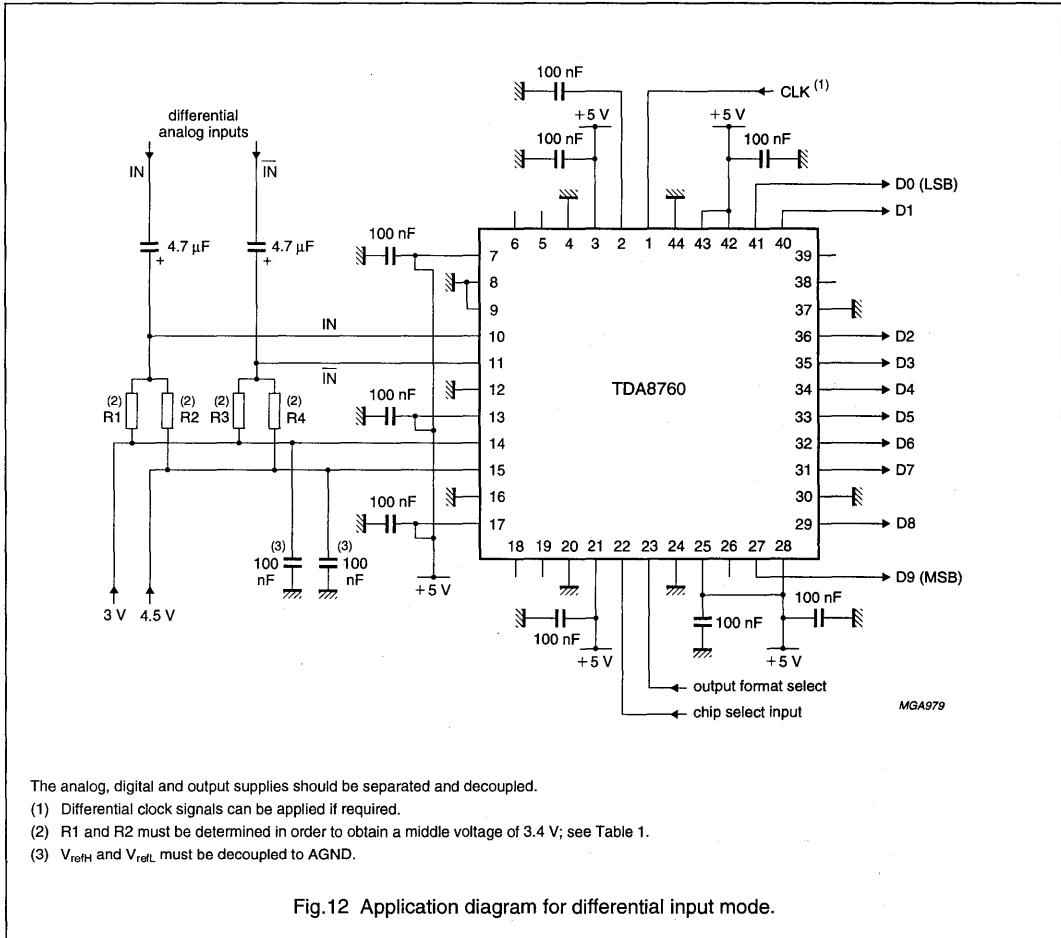

The analog, digital and output supplies should be separated and decoupled.

- (1) Differential clock signals can be applied if required.
- (2) R1 and R2 must be determined in order to obtain a middle voltage of 3.4 V; see Table 1.
- (3)  $V_{refH}$  and  $V_{refL}$  must be decoupled to AGND.

Fig.12 Application diagram for differential input mode.

10-bit high-speed analog-to-digital  
converter

TDA8760

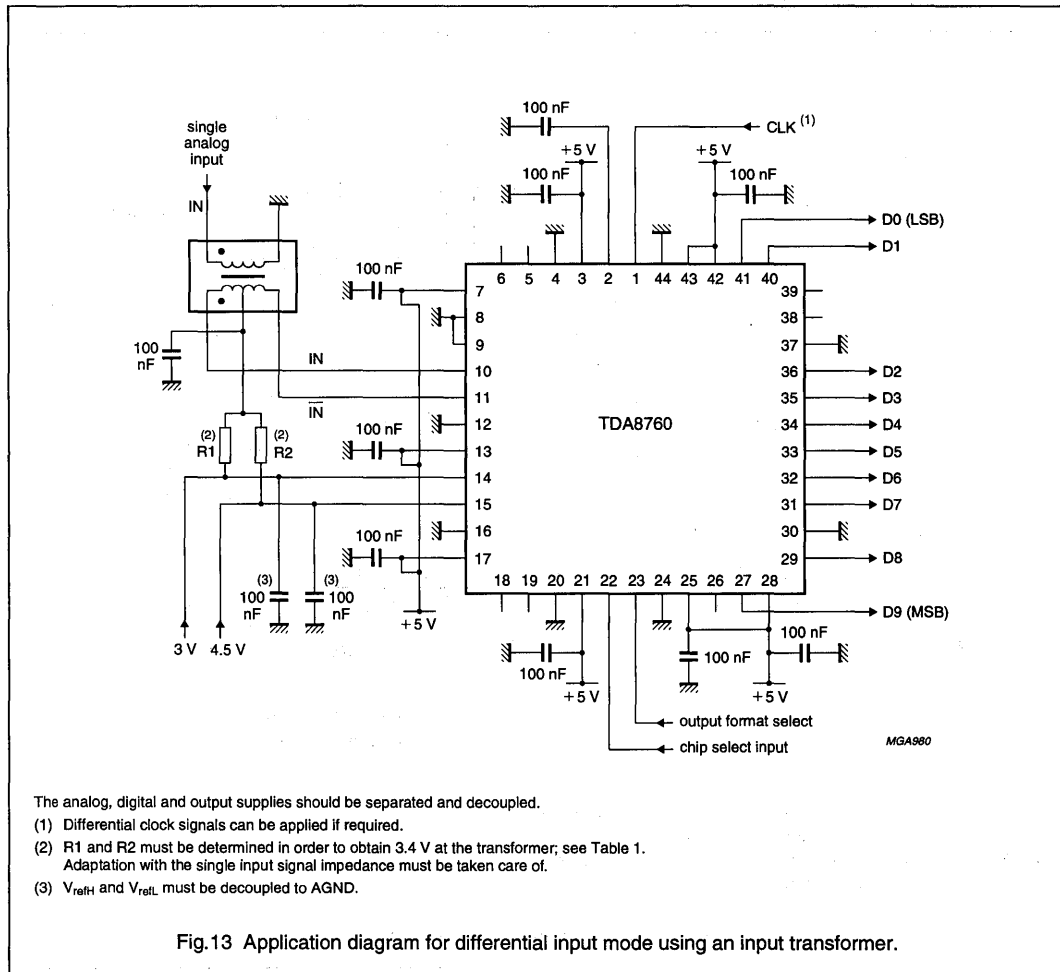

# 10-bit high-speed analog-to-digital converter

## TDA8760

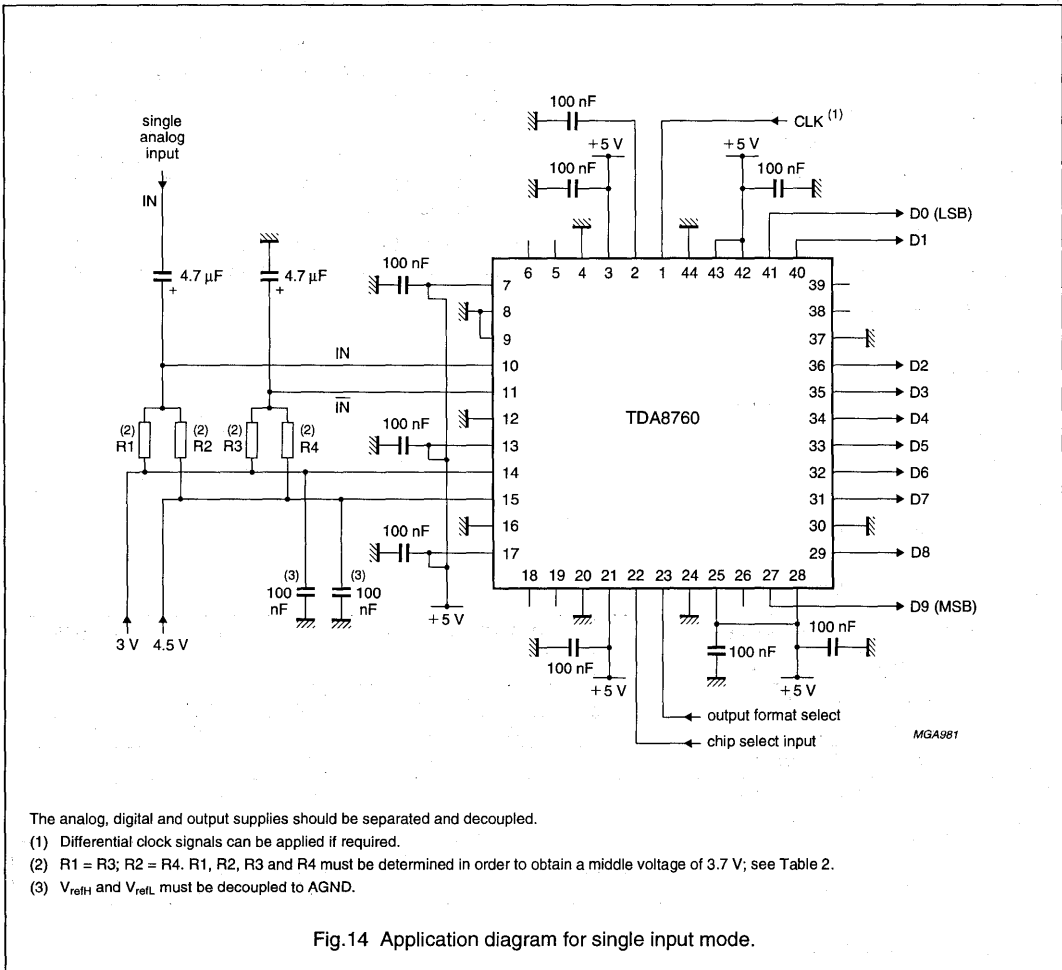

## Triple 8-bit video digital-to-analog converter

## TDA8771

### FEATURES

- 8-bit resolution
- Sampling rate up to 35 MHz
- Internal reference voltage regulator
- No deglitching circuit required
- Large output voltage range
- 1 k $\Omega$  output load
- Power dissipation only 200 mW
- Single 5 V power supply
- 44-pin QFP package.

### APPLICATIONS

- General purpose high-speed digital-to-analog conversion
- Digital TV
- Graphic display
- Desktop video processing.

### GENERAL DESCRIPTION

The TDA8771 is a triple 8-bit video digital-to-analog converter (DAC). It converts the digital input signals into analog voltage outputs at a maximum conversion rate of 35 MHz.

The DACs are based on resistor-string architecture with integrated output buffers. The output voltage range is determined by a built-in reference source.

The device is fabricated in a 5 V, CMOS process that ensures high functionality with low power dissipation.

### QUICK REFERENCE DATA

SYMBOL	PARAMETER	CONDITIONS	MIN.	TYP.	MAX.	UNIT
V <sub>DDA</sub>	analog supply voltage		4.5	5.0	5.5	V
V <sub>DDD</sub>	digital supply voltage		4.5	5.0	5.5	V
I <sub>DDA</sub>	analog supply current	R <sub>L</sub> = 1 k $\Omega$	–	33	45	mA
I <sub>DDD</sub>	digital supply current		–	7	20	mA
ILE	DC integral linear error		–	±0.5	±1	LSB
DLE	DC differential linearity error		–	±0.25	±0.5	LSB
f <sub>clk(max)</sub>	maximum clock frequency		35	–	–	MHz
P <sub>tot</sub>	total power dissipation	R <sub>L</sub> = 1 k $\Omega$	–	200	360	mW

### ORDERING INFORMATION

TYPE NUMBER	PACKAGE			
	PINS	PIN POSITION	MATERIAL	CODE
TDA8771H	44	QFP	plastic	SOT307-2

# Triple 8-bit video digital-to-analog converter

TDA8771

## BLOCK DIAGRAM

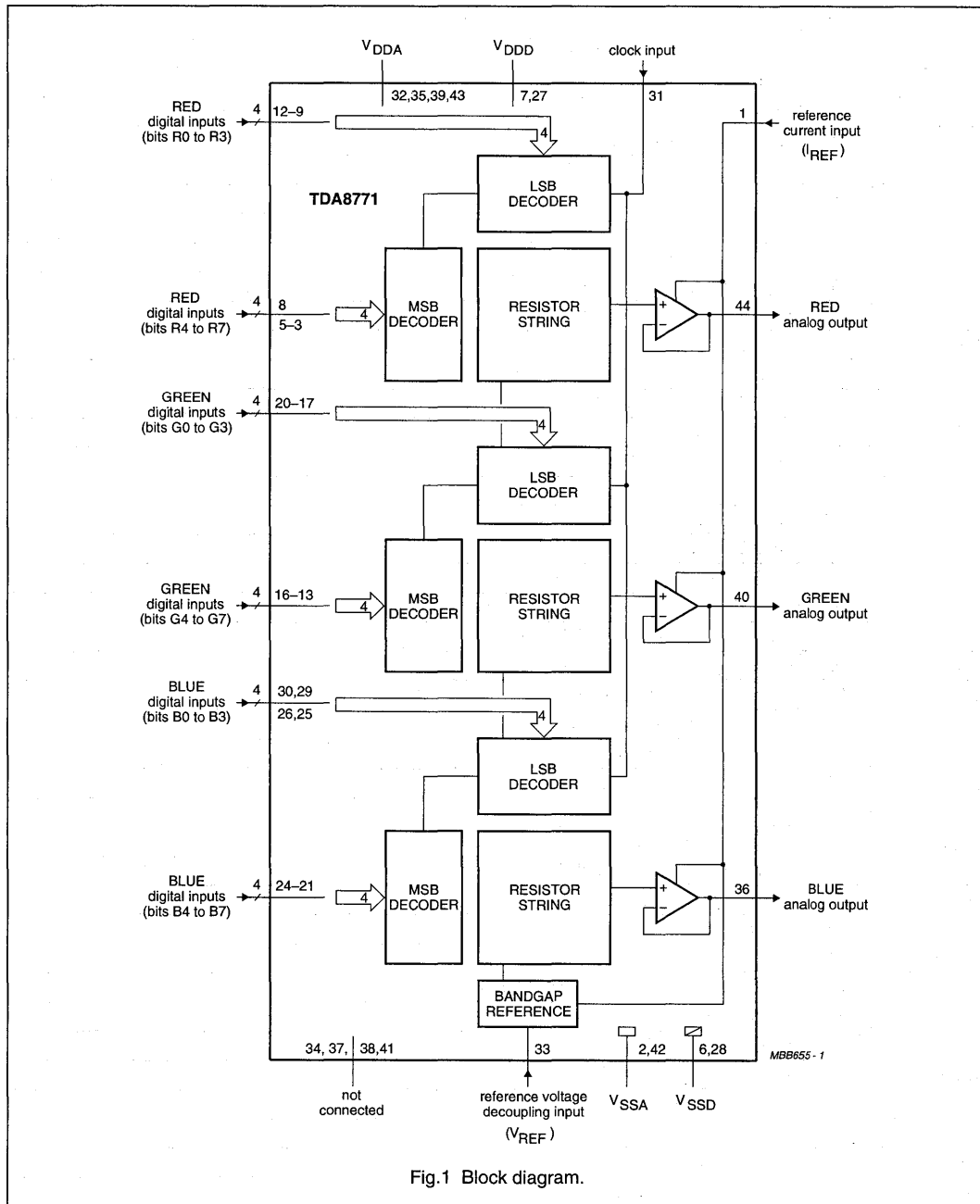

Fig.1 Block diagram.

# Triple 8-bit video digital-to-analog converter

TDA8771

## PINNING

SYMBOL	PIN	DESCRIPTION
I <sub>REF</sub>	1	reference current input for output buffers
V <sub>SSA1</sub>	2	analog supply ground 1
R7	3	RED digital input data; bit 7 (MSB)
R6	4	RED digital input data; bit 6
R5	5	RED digital input data; bit 5
V <sub>SSD1</sub>	6	digital supply ground 1
V <sub>DDD1</sub>	7	digital supply voltage 1
R4	8	RED digital input data; bit 4
R3	9	RED digital input data; bit 3
R2	10	RED digital input data; bit 2
R1	11	RED digital input data; bit 1
R0	12	RED digital input data; bit 0 (LSB)
G7	13	GREEN digital input data; bit 7 (MSB)
G6	14	GREEN digital input data; bit 6
G5	15	GREEN digital input data; bit 5
G4	16	GREEN digital input data; bit 4
G3	17	GREEN digital input data; bit 3
G2	18	GREEN digital input data; bit 2
G1	19	GREEN digital input data; bit 1
G0	20	GREEN digital input data; bit 0 (LSB)
B7	21	BLUE digital input data; bit 7 (MSB)
B6	22	BLUE digital input data; bit 6
B5	23	BLUE digital input data; bit 5
B4	24	BLUE digital input data; bit 4
B3	25	BLUE digital input data; bit 3
B2	26	BLUE digital input data; bit 2
V <sub>DDD2</sub>	27	digital supply voltage 2
V <sub>SSD2</sub>	28	digital supply ground 2
B1	29	BLUE digital input data; bit 1
B0	30	BLUE digital input data; bit 0 (LSB)
CLK	31	clock input
V <sub>DDA1</sub>	32	analog supply voltage 1
V <sub>REF</sub>	33	decoupling input for reference voltage
n.c.	34	not connected
V <sub>DDA2</sub>	35	analog supply voltage 2
OUTB	36	BLUE analog output
n.c.	37	not connected
n.c.	38	not connected
V <sub>DDA3</sub>	39	analog supply voltage 3
OUTG	40	GREEN analog output

# Triple 8-bit video digital-to-analog converter

TDA8771

SYMBOL	PIN	DESCRIPTION
n.c.	41	not connected
V <sub>SSA2</sub>	42	analog supply ground 2
V <sub>DDA4</sub>	43	analog supply voltage 4
OUTR	44	RED analog output

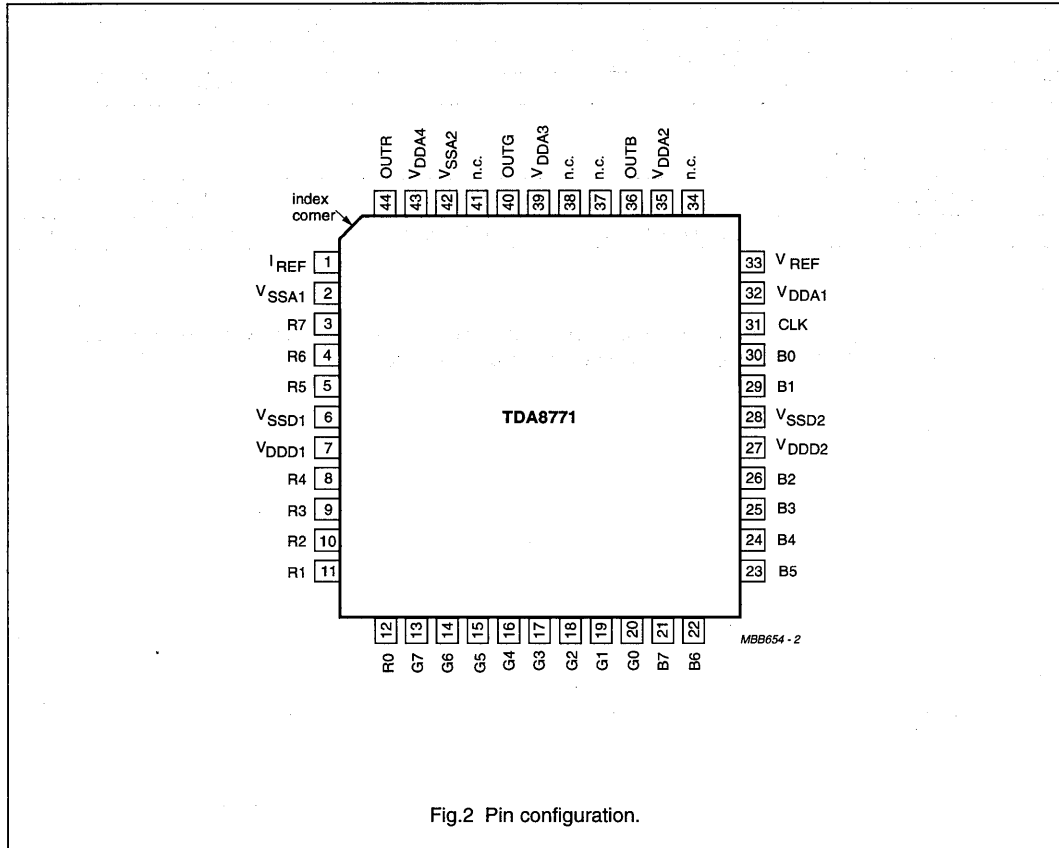

Fig.2 Pin configuration.

# Triple 8-bit video digital-to-analog converter

TDA8771

## LIMITING VALUES

In accordance with the Absolute Maximum Rating System (IEC134).

SYMBOL	PARAMETER	MIN.	MAX.	UNIT
$V_{DDA}$	analog supply voltage	-0.5	+6.5	V
$V_{DDD}$	digital supply voltage	-0.5	+6.5	V
$\Delta V_{DD}$	supply voltage difference between $V_{DDA}$ and $V_{DDD}$	-1.0	+1.0	V
$T_{stg}$	storage temperature	-55	+150	°C
$T_{amb}$	operating ambient temperature	0	+70	°C
$T_j$	junction temperature	-	+125	°C

## THERMAL CHARACTERISTICS

SYMBOL	PARAMETER	VALUE	UNIT
$R_{th\ j-a}$	thermal resistance from junction to ambient in free air	75	K/W

## HANDLING

Inputs and outputs are protected against electrostatic discharges in normal handling. However, to be totally safe, it is desirable to take normal precautions appropriate to handling integrated circuits.



# Triple 8-bit video digital-to-analog converter

TDA8771

## CHARACTERISTICS

$V_{DDA} = V_{DDD} = 4.5$  to  $5.5$  V;  $V_{SSA}$  and  $V_{SSD}$  shorted together;  $V_{DDA} - V_{DDD} = -0.5$  to  $+0.5$  V;  $T_{amb} = 0$  to  $+70$  °C; typical values measured at  $V_{DDA} = V_{DDD} = 5$  V and  $T_{amb} = 25$  °C; unless otherwise specified.

SYMBOL	PARAMETER	CONDITIONS	MIN.	TYP.	MAX.	UNIT
<b>Supply</b>						
$V_{DDA}$	analog supply voltage		4.5	5.0	5.5	V
$V_{DDD}$	digital supply voltage		4.5	5.0	5.5	V
$I_{DDA}$	analog supply current	$R_L = 1$ k $\Omega$	–	33	45	mA
$I_{DDD}$	digital supply current	$f_{clk} = 35$ MHz	–	7	20	mA
<b>Inputs</b>						
CLOCK INPUT (PIN 31)						
$V_{IL}$	LOW level input voltage		0	–	1.2	V
$V_{IH}$	HIGH level input voltage		2.0	–	$V_{DDD}$	V
R, G, B digital inputs (pins 12 to 8, 5 to 3, 20 to 13, 30, 29 and 26 to 21)						
$V_{IL}$	LOW level input voltage		0	–	1.2	V
$V_{IH}$	HIGH level input voltage		2.0	–	$V_{DDD}$	V
$I_{REF}$ REFERENCE CURRENT INPUT FOR OUTPUT BUFFERS (PIN 1)						
$I_I$	input current		–	0.6	0.7	mA
<b>Timing (see Fig.3)</b>						
$f_{clk(max)}$	maximum clock frequency		35	–	–	MHz
$\delta_{clk}$	clock duty factor		40	–	60	%
$t_r$	clock rise time		–	–	5	ns
$t_f$	clock fall time		–	–	6	ns
$t_{SU,DAT}$	input data set-up time		4	–	–	ns
$t_{HD,DAT}$	input data hold time		4	–	–	ns
<b>Voltage reference (pin 33, referenced to <math>V_{SSA}</math>)</b>						
$V_{REF}$	output reference voltage		1.180	1.242	1.305	V
<b>Outputs</b>						
OUTB, OUTR, OUTG ANALOG OUTPUTS (PINS 36, 44 AND 40, REFERENCED TO $V_{SSA}$ ) FOR 1 k $\Omega$ LOAD; SEE TABLE 1						
FSR	full-scale output voltage range		2.80	2.95	3.10	V
$V_{os}$	offset of analog voltage output		–	0.25	–	V
$V_{Omax}$	maximum output voltage	data inputs = logic 1; note 1	2.95	3.20	3.45	V
$V_{Omin}$	minimum output voltage	data inputs = logic 0; note 1	0.05	0.25	0.45	V
THD	total harmonic distortion	$f_i = 4.43$ MHz; $f_{clk} = 35$ MHz	–	–44	–	dB
$Z_L$	output load impedance		0.9	1.0	1.1	k $\Omega$

# Triple 8-bit video digital-to-analog converter

TDA8771

SYMBOL	PARAMETER	CONDITIONS	MIN.	TYP.	MAX.	UNIT
<b>Transfer function (<math>f_{\text{clk}} = 35 \text{ MHz}</math>)</b>						
ILE	DC integral linear error		–	$\pm 0.5$	$\pm 1$	LSB
DLE	DC differential linearity error		–	$\pm 0.25$	$\pm 0.5$	LSB
$\alpha_{\text{CT}}$	crosstalk DAC to DAC		–50	–	–	dB
	DAC to DAC matching		–	1.0	2.0	%
<b>Switching characteristics (for 1 k<math>\Omega</math> output load; see Fig.4)</b>						
$t_{\text{d}}$	input to 50% output delay time	full-scale change	–	12	–	ns
$t_{\text{s1}}$	settling time	10% to 90% of full-scale change	–	15	–	ns
$t_{\text{s2}}$	settling time	to $\pm 1$ LSB	–	50	–	ns
<b>Output transients (glitches)</b>						
$V_{\text{g}}$	area for 1 LSB change		–	1	–	LSB·ns

**Note**

- $V_{\text{O}}$  is directly proportional to  $V_{\text{REF}}$ .

**Table 1** Input coding and DAC output voltages (typical values).

BINARY INPUT DATA (SYNC = BLANK = 0)	CODE	DAC OUTPUT VOLTAGES (V) OUTB, OUTR, OUTG $R_{\text{L}} = 1 \text{ k}\Omega$
0000 0000	0	0.262
0000 0001	1	0.273
.... ....	.	.
1000 0000	128	1.731
.... ....	.	.
1111 1110	254	3.188
1111 1111	255	3.200

# Triple 8-bit video digital-to-analog converter

TDA8771

## TIMING

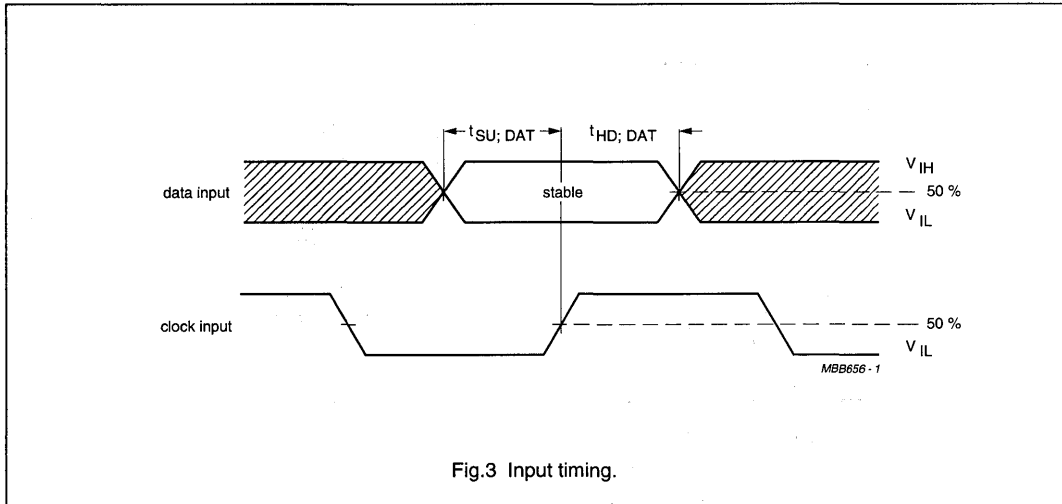

Fig.3 Input timing.

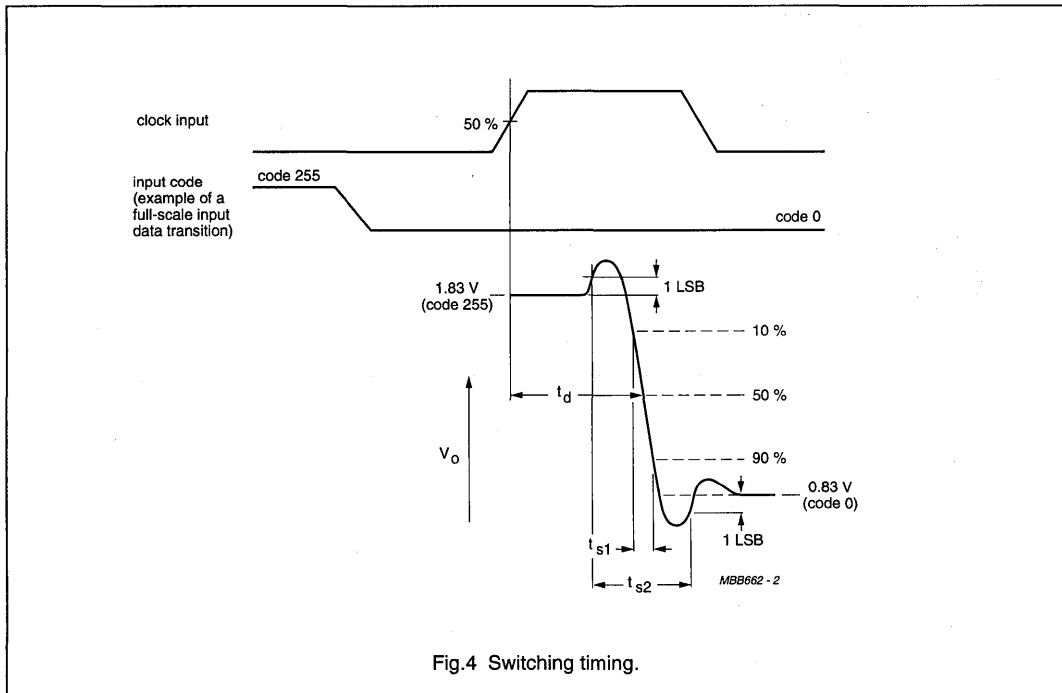
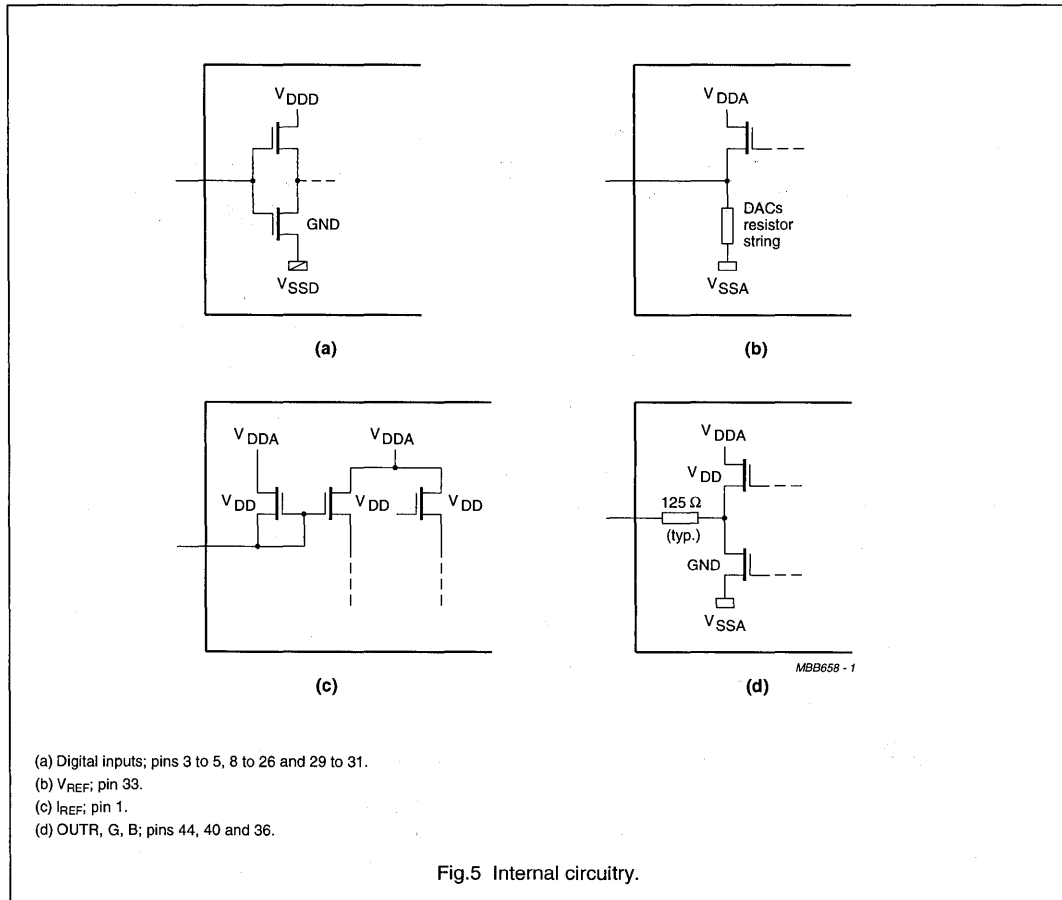

Fig.4 Switching timing.

Triple 8-bit video digital-to-analog converter

TDA8771

INTERNAL CIRCUITRY



- (a) Digital inputs; pins 3 to 5, 8 to 26 and 29 to 31.
- (b)  $V_{REF}$ ; pin 33.
- (c)  $I_{REF}$ ; pin 1.
- (d) OUTR, G, B; pins 44, 40 and 36.

Fig.5 Internal circuitry.

# Triple 8-bit video digital-to-analog converter

TDA8771

## APPLICATION INFORMATION

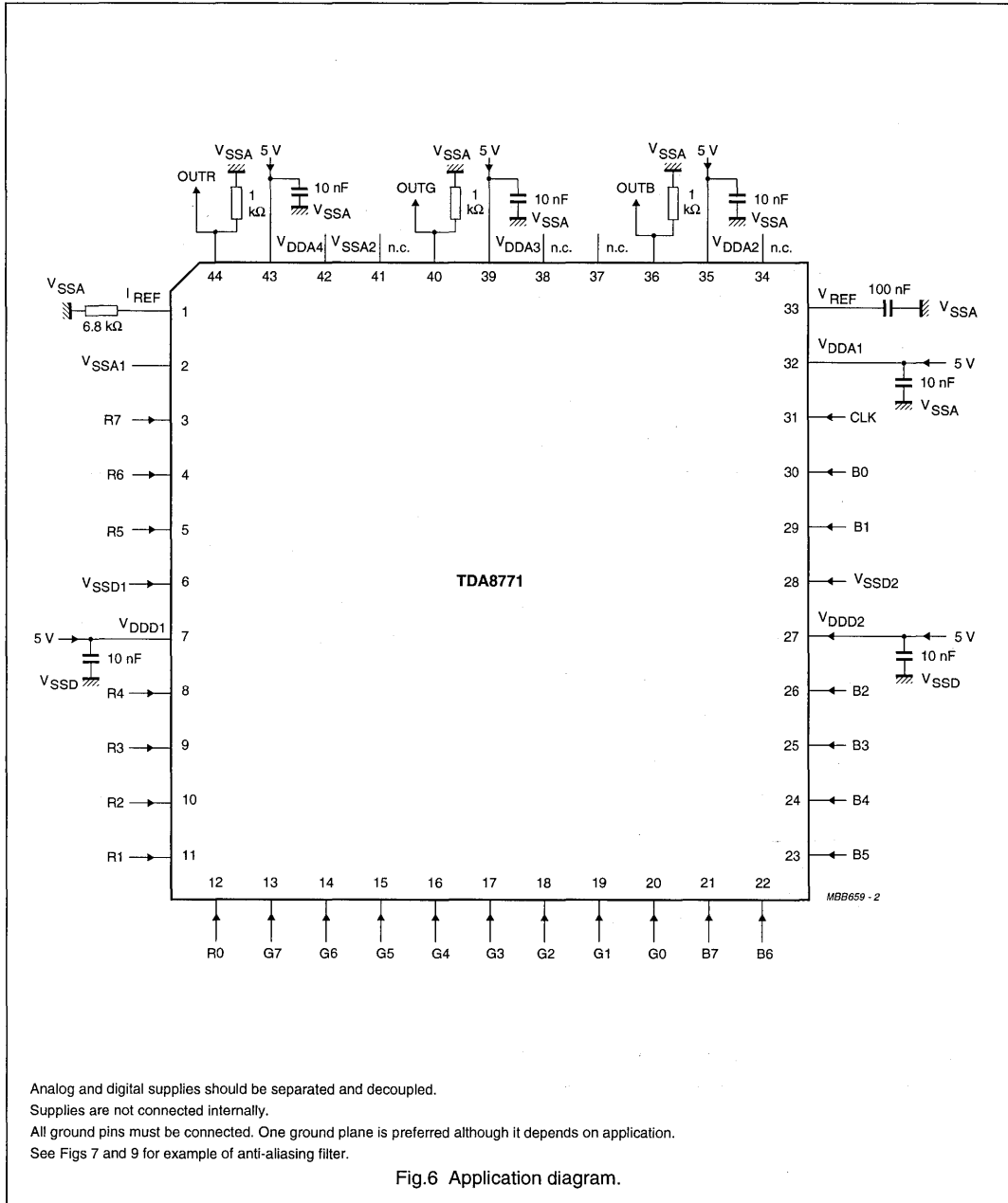

Analog and digital supplies should be separated and decoupled.  
 Supplies are not connected internally.  
 All ground pins must be connected. One ground plane is preferred although it depends on application.  
 See Figs 7 and 9 for example of anti-aliasing filter.

Fig.6 Application diagram.

Triple 8-bit video digital-to-analog converter

TDA8771

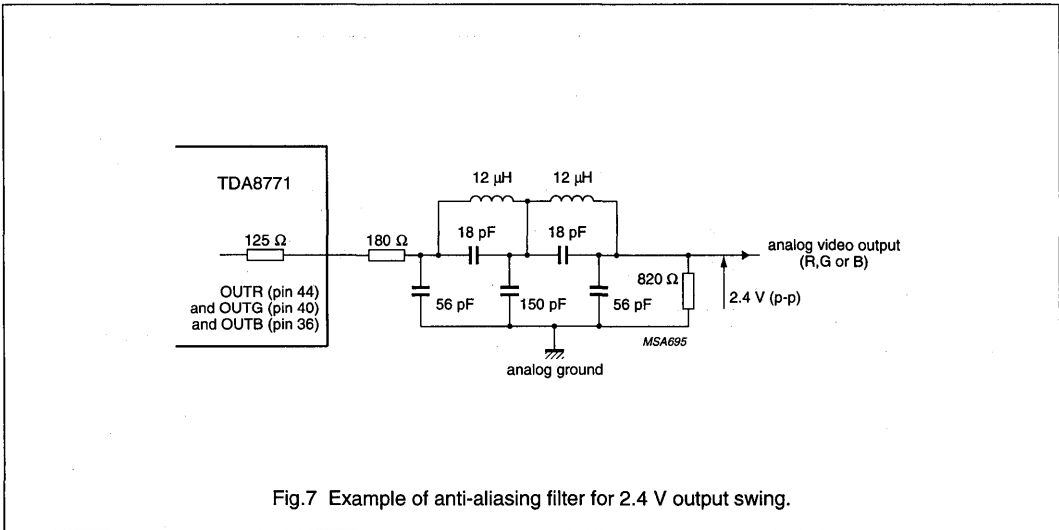

Fig.7 Example of anti-aliasing filter for 2.4 V output swing.

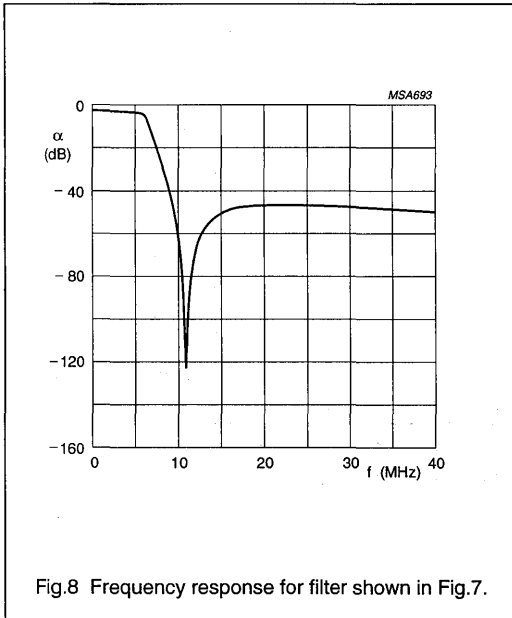

Fig.8 Frequency response for filter shown in Fig.7.

Characteristics of Fig.7

- Order 5; adapted CHEBYSHEV
- Ripple  $\rho \geq 0.7$  dB
- $f$  at  $-3$  dB = 6.2 MHz
- $f_{NOTCH} = 10.8$  MHz.

# Triple 8-bit video digital-to-analog converter

## TDA8771

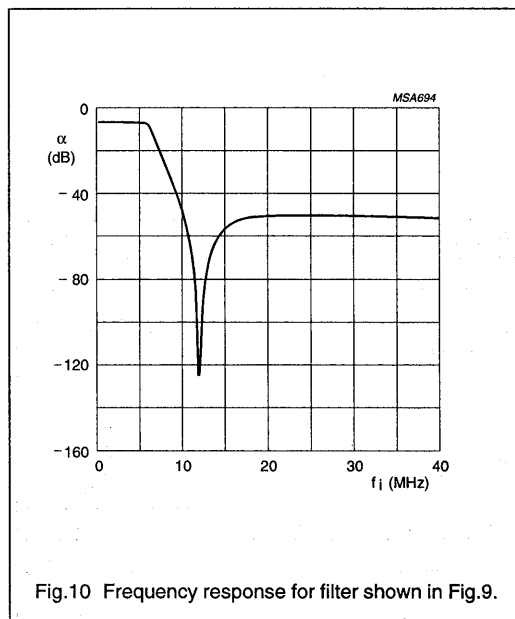
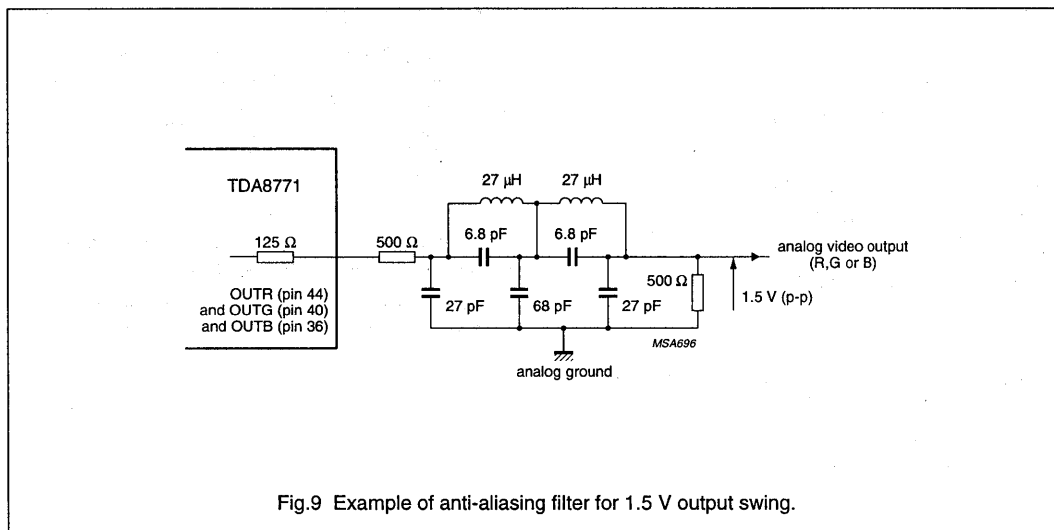

### Characteristics of Fig.10

- Order 5; adapted CHEBYSHEV
- Ripple  $\rho \geq 0.25$  dB
- $f$  at  $-3$  dB = 5.6 MHz
- $f_{\text{NOTCH}} = 11.7$  MHz.

# Triple 8-bit video digital-to-analog converter

## TDA8772; TDA8772A

### FEATURES

- 8-bit resolution
- Sampling rate up to
  - 35 MHz for TDA8772H/3, TDA8772AH/3
  - 85 MHz for TDA8772H/8, TDA8772AH/8
- Internal reference voltage regulator
- No deglitching circuit required
- SYNC, BLANK control inputs
- 3 independent clock inputs (one per DAC)
- 1 V output voltage range
- 75 Ω output load
- TDA8772A has BLANK control input on the GREEN channel only while TDA8772 has it on the 3 channels
- Single 5 V power supply
- 44-pin QFP package.

### GENERAL DESCRIPTION

The TDA8772, TDA8772A are triple 8-bit video digital-to-analog converters (DACs). They convert the digital input signals into analog voltage outputs at a maximum conversion rate of 35 MHz (TDA8772H/3, TDA8772AH/3) and 85 MHz (TDA8772H/8, TDA8772AH/8).

The DACs are based on resistor-string architecture with integrated output buffers. The output voltage range is determined by a built-in reference source.

The devices are fabricated in a 5 V CMOS process that ensures high functionality with low power dissipation.

### APPLICATIONS

- General purpose high-speed digital-to-analog conversion
- Digital TV
- Graphic display
- Desktop video processing.

### QUICK REFERENCE DATA

SYMBOL	PARAMETER	CONDITIONS	MIN.	TYP.	MAX.	UNIT
V <sub>DDA</sub>	analog supply voltage		4.5	5.0	5.5	V
V <sub>DDD</sub>	digital supply voltage		4.5	5.0	5.5	V
I <sub>DDA</sub>	analog supply current	R <sub>L</sub> = 75 Ω	–	45	85	mA
I <sub>DDD</sub>	digital supply current TDA8772H/3, TDA8772AH/3 TDA8772H/8, TDA8772AH/8		–	7	16	mA
			–	16	27	mA
ILE	DC integral linear error	f <sub>clk</sub> = 35 MHz	–	±0.5	±1	LSB
		f <sub>clk</sub> = 85 MHz	–	±0.75	tbf	LSB
DLE	DC differential linearity error	f <sub>clk</sub> = 35 MHz	–	±0.25	±0.5	LSB
		f <sub>clk</sub> = 85 MHz	–	±0.5	tbf	LSB
f <sub>clk(max)</sub>	maximum clock frequency TDA8772H/3, TDA8772AH/3 TDA8772H/8, TDA8772AH/8		35	–	–	MHz
			85	–	–	MHz
P <sub>tot</sub>	total power dissipation TDA8772H/3, TDA8772AH/3 TDA8772H/8, TDA8772AH/8	R <sub>L</sub> = 75 Ω	–	260	530	mW
		R <sub>L</sub> = 75 Ω	–	310	590	mW



---

**Triple 8-bit video digital-to-analog  
converter**

---

**TDA8772; TDA8772A****ORDERING INFORMATION**

TYPE NUMBER	PACKAGE				SAMPLING FREQUENCY
	PINS	PIN POSITION	MATERIAL	CODE	
TDA8772H/3	44	QFP44	plastic	SOT307B	35 MHz
TDA8772AH/3	44	QFP44	plastic	SOT307B	35 MHz
TDA8772H/8	44	QFP44	plastic	SOT307B	85 MHz
TDA8772AH/8	44	QFP44	plastic	SOT307B	85 MHz

# Triple 8-bit video digital-to-analog converter

TDA8772; TDA8772A

## BLOCK DIAGRAMS

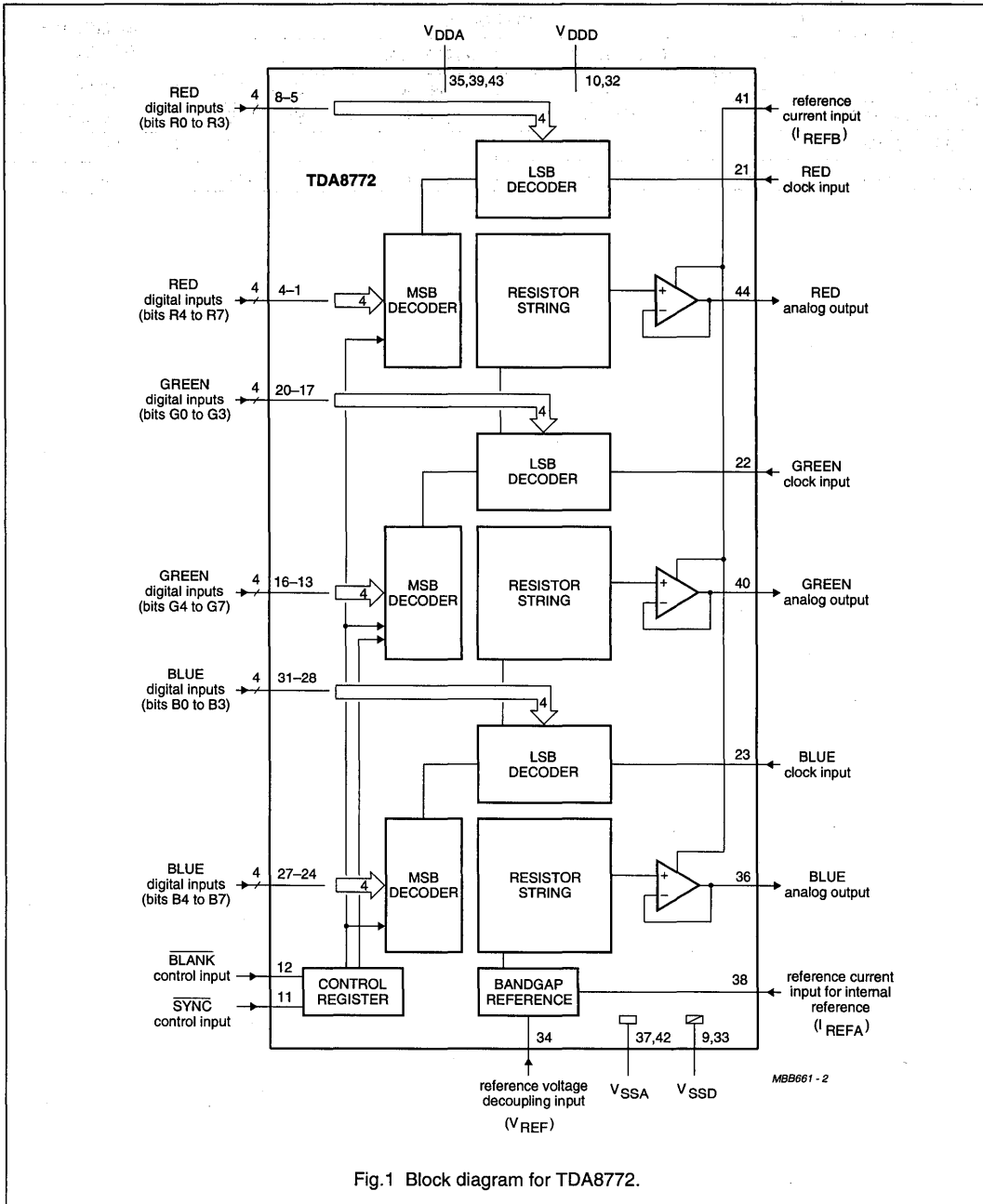

Fig.1 Block diagram for TDA8772.

# Triple 8-bit video digital-to-analog converter

TDA8772; TDA8772A

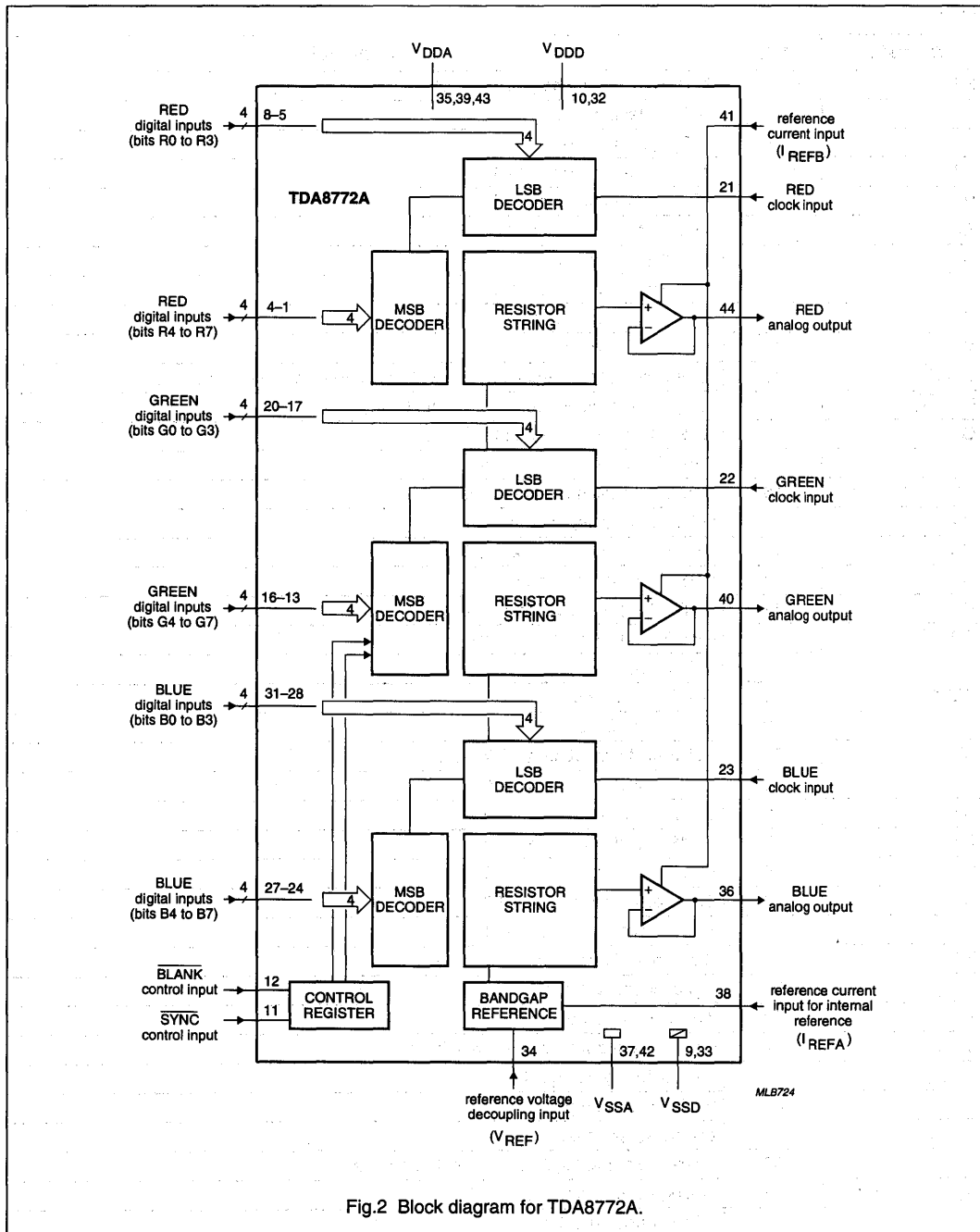

Fig.2 Block diagram for TDA8772A.

# Triple 8-bit video digital-to-analog converter

TDA8772; TDA8772A

**PINNING**

SYMBOL	PIN	DESCRIPTION
R7	1	RED digital input data; bit 7 (MSB)
R6	2	RED digital input data; bit 6
R5	3	RED digital input data; bit 5
R4	4	RED digital input data; bit 4
R3	5	RED digital input data; bit 3
R2	6	RED digital input data; bit 2
R1	7	RED digital input data; bit 1
R0	8	RED digital input data; bit 0 (LSB)
V <sub>SSD1</sub>	9	digital supply ground 1
V <sub>DD1</sub>	10	digital supply voltage 1
SYNC	11	composite sync control input; for GREEN channel only (active LOW)
BLANK	12	composite blank control input (active LOW)
G7	13	GREEN digital input data; bit 7 (MSB)
G6	14	GREEN digital input data; bit 6
G5	15	GREEN digital input data; bit 5
G4	16	GREEN digital input data; bit 4
G3	17	GREEN digital input data; bit 3
G2	18	GREEN digital input data; bit 2
G1	19	GREEN digital input data; bit 1
G0	20	GREEN digital input data; bit 0 (LSB)
CLKR	21	RED clock input
CLKG	22	GREEN clock input
CLKB	23	BLUE clock input
B7	24	BLUE digital input data; bit 7 (MSB)
B6	25	BLUE digital input data; bit 6
B5	26	BLUE digital input data; bit 5
B4	27	BLUE digital input data; bit 4
B3	28	BLUE digital input data; bit 3
B2	29	BLUE digital input data; bit 2
B1	30	BLUE digital input data; bit 1
B0	31	BLUE digital input data; bit 0 (LSB)
V <sub>DD2</sub>	32	digital supply voltage 2
V <sub>SS2</sub>	33	digital supply ground 2
V <sub>REF</sub>	34	decoupling input for reference voltage
V <sub>DDA1</sub>	35	analog supply voltage 1
OUTB	36	BLUE analog output
V <sub>SSA1</sub>	37	analog supply ground 1
I <sub>REFA</sub>	38	reference current input for internal reference
V <sub>DDA2</sub>	39	analog supply voltage 2
OUTG	40	GREEN analog output

Triple 8-bit video digital-to-analog converter

TDA8772; TDA8772A

SYMBOL	PIN	DESCRIPTION
I <sub>REFB</sub>	41	reference current input for output buffers
V <sub>SSA2</sub>	42	analog supply ground 2
V <sub>DDA3</sub>	43	analog supply voltage 3
OUTR	44	RED analog output

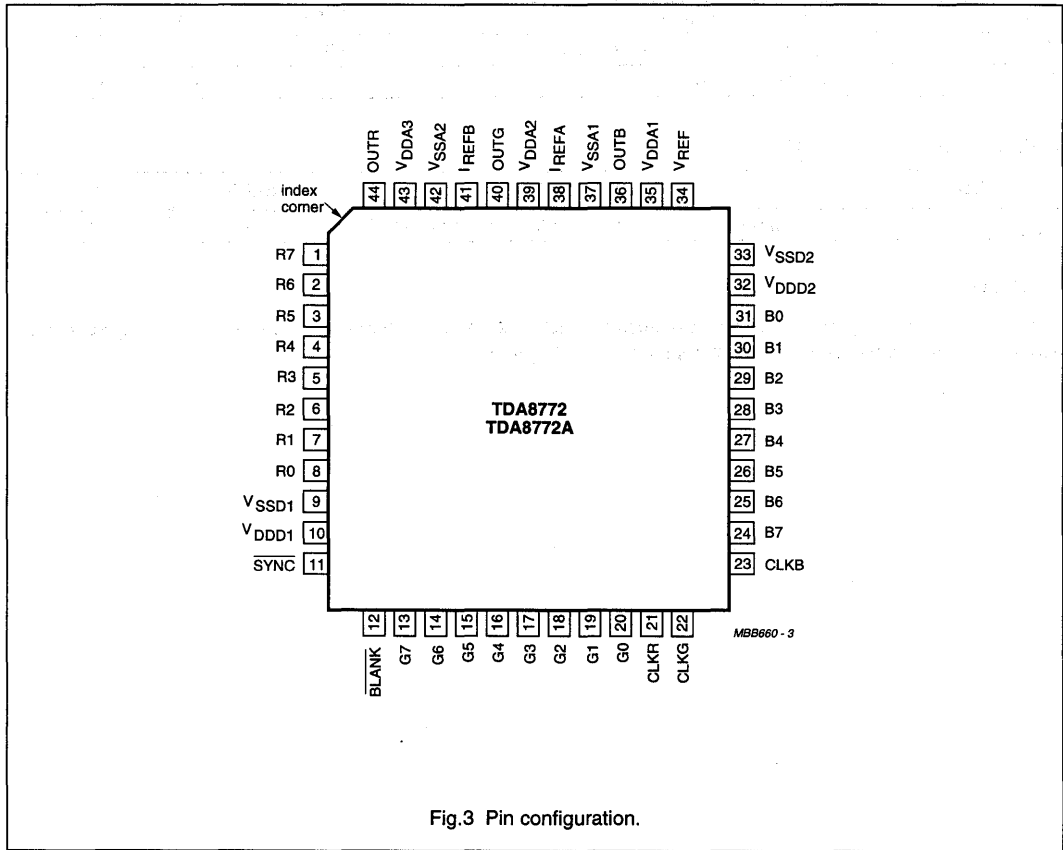

Fig.3 Pin configuration.

# Triple 8-bit video digital-to-analog converter

## TDA8772; TDA8772A

### LIMITING VALUES

In accordance with the Absolute Maximum Rating System (IEC134).

SYMBOL	PARAMETER	MIN.	MAX.	UNIT
$V_{DDA}$	analog supply voltage	-0.5	+6.5	V
$V_{DDD}$	digital supply voltage	-0.5	+6.5	V
$\Delta V_{DD}$	supply voltage differences between $V_{DDA}$ and $V_{DDD}$	-1.0	+1.0	V
$T_{stg}$	storage temperature	-55	+150	°C
$T_{amb}$	operating ambient temperature	0	+70	°C
$T_j$	junction temperature	-	+125	°C

### THERMAL CHARACTERISTICS

SYMBOL	PARAMETER	VALUE	UNIT
$R_{th\ j-a}$	thermal resistance from junction to ambient in free air	75	K/W

### HANDLING

Inputs and outputs are protected against electrostatic discharges in normal handling. However, to be totally safe, it is desirable to take normal precautions appropriate to handling integrated circuits.

# Triple 8-bit video digital-to-analog converter

## TDA8772; TDA8772A

### CHARACTERISTICS

TDA8772H/3, TDA8772AH/3 operating at 35 MHz and TDA8772H/8, TDA8772AH/8 operating at 85 MHz unless otherwise specified.

$V_{DDA} = V_{DDD} = 4.5 \text{ V}$  to  $5.5 \text{ V}$ ;  $V_{SSA}$  and  $V_{SSD}$  shorted together;  $V_{DDA} - V_{DDD} = -0.5 \text{ V}$  to  $+0.5 \text{ V}$ ;  $T_{amb} = 0$  to  $+70 \text{ }^\circ\text{C}$ ; typical values measured at  $V_{DDA} = V_{DDD} = 5 \text{ V}$  and  $T_{amb} = 25 \text{ }^\circ\text{C}$ ; unless otherwise specified.

SYMBOL	PARAMETER	CONDITIONS	MIN.	TYP.	MAX.	UNIT
<b>Supply</b>						
$V_{DDA}$	analog supply voltage		4.5	5.0	5.5	V
$V_{DDD}$	digital supply voltage		4.5	5.0	5.5	V
$I_{DDA}$	analog supply current	$R_L = 75 \text{ } \Omega$	–	45	85	mA
$I_{DDD}$	digital supply current					
	TDA8772H/3, TDA8772AH/3		–	7	16	mA
	TDA8772H/8, TDA8772AH/8		–	16	27	mA
<b>Inputs</b>						
CLOCK INPUTS (PINS 21, 22 AND 23)						
$V_{IL}$	LOW level input voltage		$V_{SSD} - 0.5$	–	0.8	V
$V_{IH}$	HIGH level input voltage		2.0	–	$V_{DDD} + 0.5$	V
BLANK, SYNC INPUTS (PINS 12 AND 11; ACTIVE LOW)						
$V_{IL}$	LOW level input voltage		$V_{SSD} - 0.5$	–	0.8	V
$V_{IH}$	HIGH level input voltage		2.0	–	$V_{DDD} + 0.5$	V
R, G, B DIGITAL INPUTS (PINS 1 TO 8, 13 TO 20 AND 24 TO 31)						
$V_{IL}$	LOW level input voltage		$V_{SSD} - 0.5$	–	0.8	V
$V_{IH}$	HIGH level input voltage		2.0	–	$V_{DDD} + 0.5$	V
$I_{REFA}$ INTERNAL REFERENCE SUPPLY CURRENT (PIN 38)						
$I_i$	input current		–	0.17	0.25	mA
$I_{REFB}$ OUTPUT BUFFER SUPPLY CURRENT (PIN 41)						
$I_i$	input current		–	0.5	0.7	mA
<b>Timing (<math>C_L = 25 \text{ pF}</math>; <math>R_L = 75 \text{ } \Omega</math>; see Fig.4)</b>						
$f_{clk(max)}$	maximum clock frequency					
	TDA8772H/3, TDA8772AH/3		35	–	–	MHz
	TDA8772H/8, TDA8772AH/8		85	–	–	MHz
$\delta_{clk}$	clock duty factor		40	–	60	%
$t_r$	clock rise time					
	TDA8772H/3, TDA8772AH/3		–	–	5	ns
	TDA8772H/8, TDA8772AH/8		–	–	3	ns
$t_f$	clock fall time					
	TDA8772H/3, TDA8772AH/3		–	–	5	ns
	TDA8772H/8, TDA8772AH/8		–	–	3	ns
$t_{SU,DAT}$	input data set-up time		4	–	–	ns
$t_{HD,DAT}$	input data hold time		2.5	–	–	ns

Triple 8-bit video digital-to-analog  
converter

TDA8772; TDA8772A

SYMBOL	PARAMETER	CONDITIONS	MIN.	TYP.	MAX.	UNIT
<b>Voltage reference (pin 34, referenced to <math>V_{SSA}</math>)</b>						
$V_{REF}$	output reference voltage		1.180	1.242	1.305	V
<b>Outputs</b>						
OUTB, OUTR, OUTG ANALOG OUTPUTS (PINS 36, 44 AND 40, REFERENCED TO $V_{SSA}$ ) FOR 75 $\Omega$ LOAD; SEE TABLES 1 AND 2						
FSR	full-scale output voltage range		0.9	1.0	1.1	V
$V_{os}$	offset of analog voltage output		0.75	0.83	0.95	V
$V_{OUTmax}$	maximum output voltage	data inputs = logic 1; note 1	1.65	1.83	2.05	V
$V_{OUTmin}$	minimum output voltage	data inputs = logic 0; note 1	0.75	0.83	0.95	V
THD	total harmonic distortion	$f_i = 4.43$ MHz; $f_{clk} = 35$ MHz	–	–41	–	dB
		$f_i = 4.43$ MHz; $f_{clk} = 85$ MHz	–	–40	–	dB
$Z_L$	output load impedance		60	75	90	$\Omega$
<b>Transfer function (<math>f_{clk} = 85</math> MHz)</b>						
ILE	DC integral linear error	$f_{clk} = 35$ MHz	–	$\pm 0.5$	$\pm 1$	LSB
		$f_{clk} = 85$ MHz	–	$\pm 0.75$	tbf	LSB
DLE	DC differential linearity error	$f_{clk} = 35$ MHz	–	$\pm 0.25$	$\pm 0.5$	LSB
		$f_{clk} = 85$ MHz	–	$\pm 0.5$	tbf	LSB
$\alpha_{CT}$	crosstalk DAC to DAC		–45	–	–	dB
	DAC to DAC matching		–	1.0	2.0	%
<b>Switching characteristics (for 75 <math>\Omega</math> output load; see Fig.5)</b>						
$t_d$	input to 50% output delay time	full-scale change	–	10	–	ns
$t_{s1}$	settling time	10% to 90% full-scale change	–	6	–	ns
		to $\pm 1$ LSB	–	30	–	ns
<b>Output transients (glitches)</b>						
$V_g$	area for 1 LSB change		–	1	–	LSB.ns

**Note**

- $V_{OUT}$  is directly proportional to  $V_{REF}$ .



# Triple 8-bit video digital-to-analog converter

TDA8772; TDA8772A

**Table 1** Input coding and DAC output voltages (typical values).

BINARY INPUT DATA (SYNC = BLANK = 0)	CODE	DAC OUTPUT VOLTAGES (V) OUTB, OUTR, OUTG $R_L = 75 \Omega$
0000 0000	0	0.830
0000 0001	1	0.834
.... ....	.	.
1000 0000	128	1.330
.... ....	.	.
1111 1110	254	1.826
1111 1111	255	1.830

**Table 2** Input coding and DAC output voltages (typical values).

BINARY INPUT DATA	$\overline{\text{SYNC}}$ (PIN 11)	$\overline{\text{BLANK}}$ (PIN 12)	DAC OUTPUT VOLTAGES (V)		
			OUTG (PIN 40)	OUTR/B (PIN 44, 46) TDA8772	OUTR/B (PIN 44, 46) TDA8772A
.... ....	x	1	see Table 1	see Table 1	see Table 1
.... ....	1	0	0.830	0.830	
.... ....	0	0	0.440		

Triple 8-bit video digital-to-analog  
converter

TDA8772; TDA8772A

TIMING

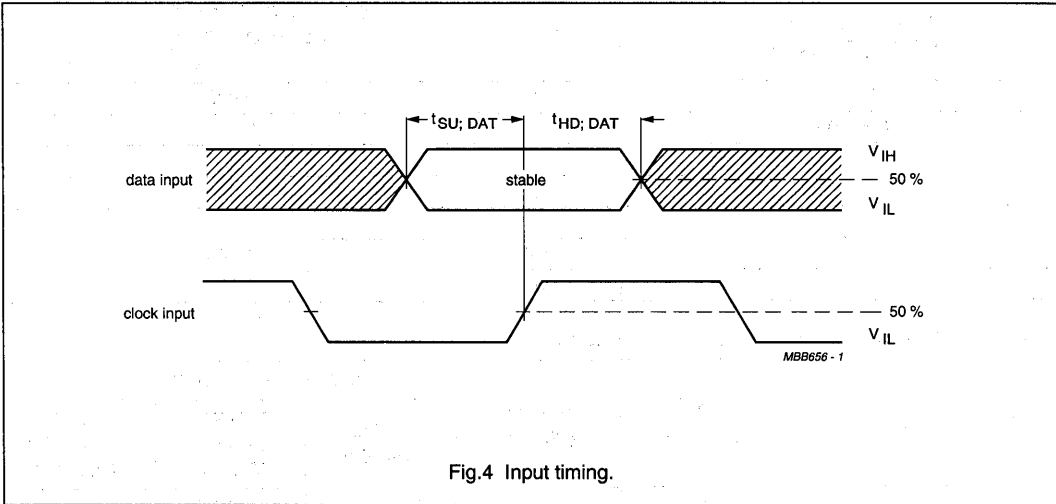

Fig.4 Input timing.

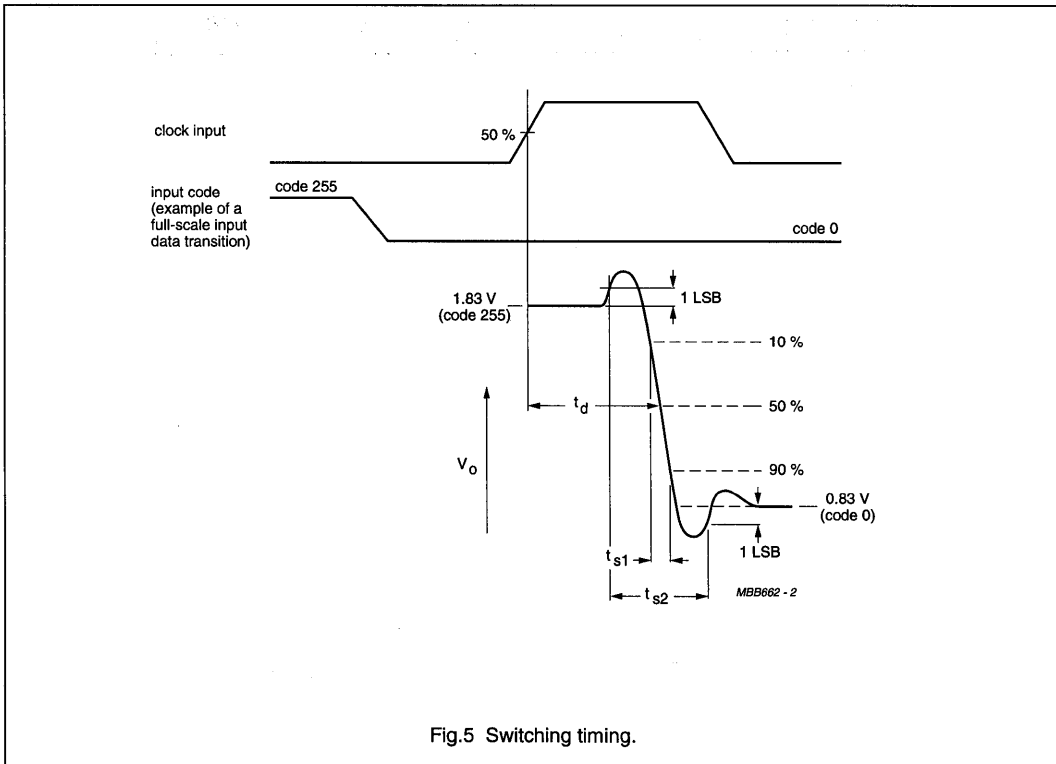
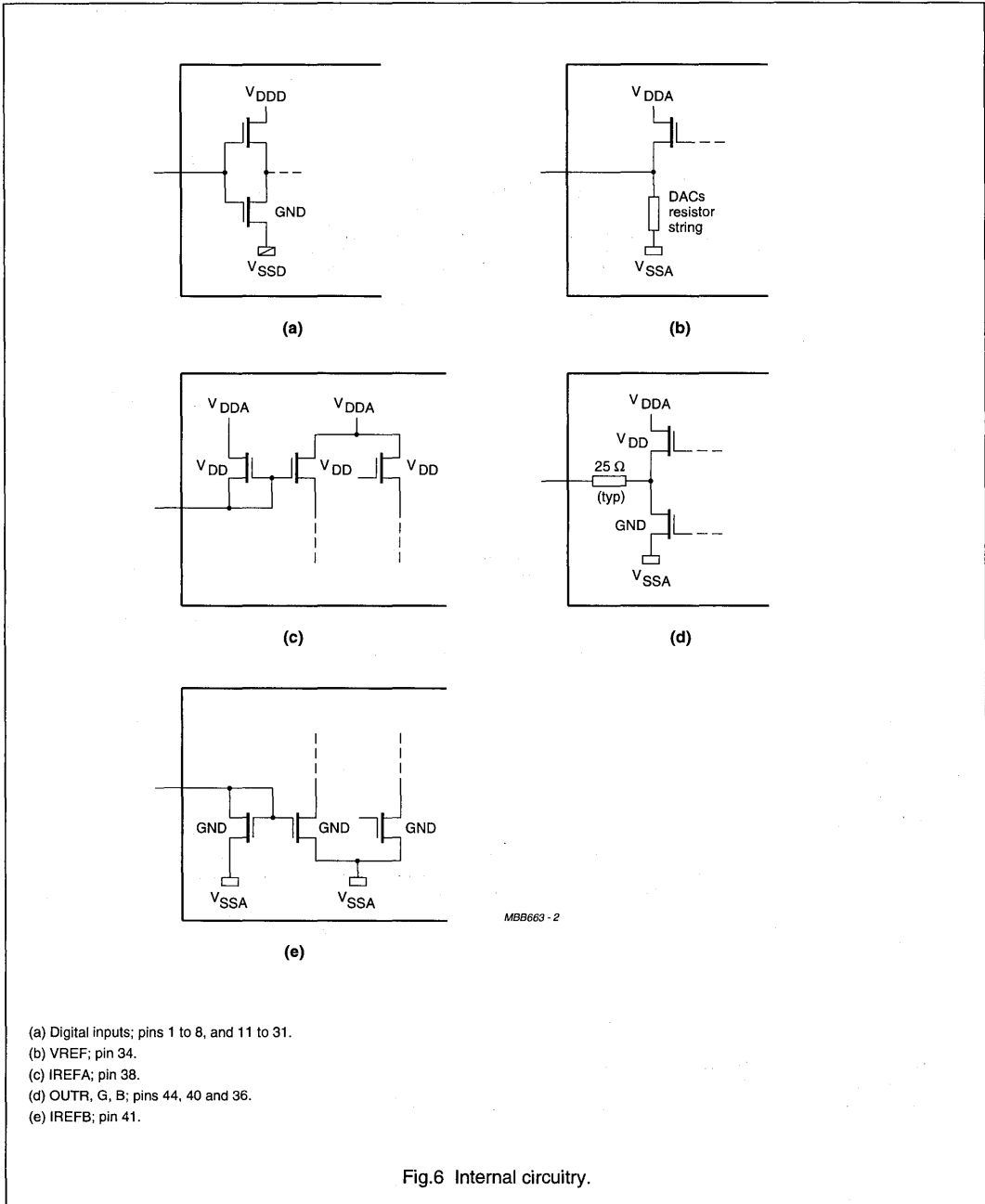

Fig.5 Switching timing.

# Triple 8-bit video digital-to-analog converter

TDA8772; TDA8772A

## INTERNAL CIRCUITRY



# Triple 8-bit video digital-to-analog converter

## TDA8772; TDA8772A

### APPLICATION INFORMATION

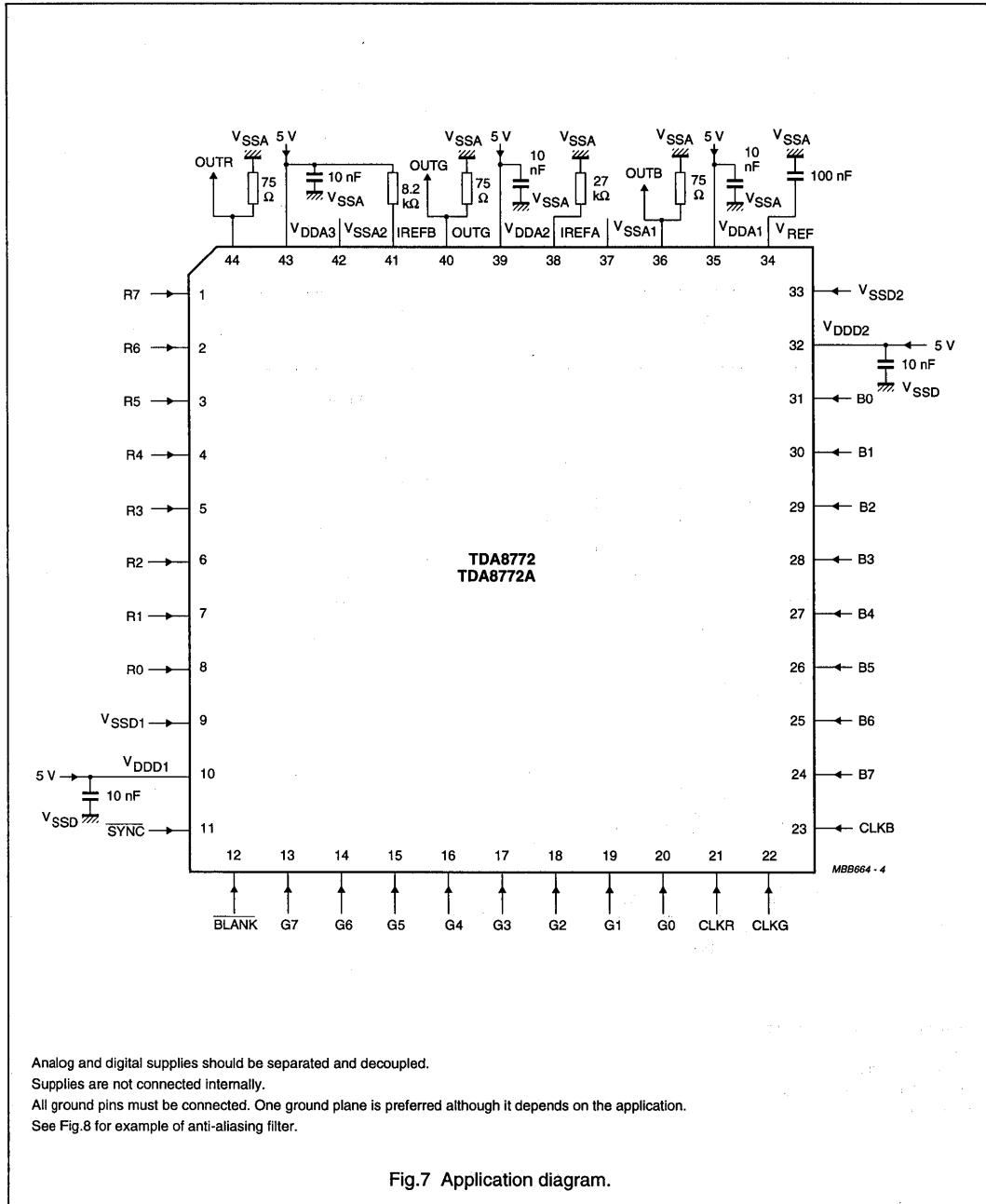
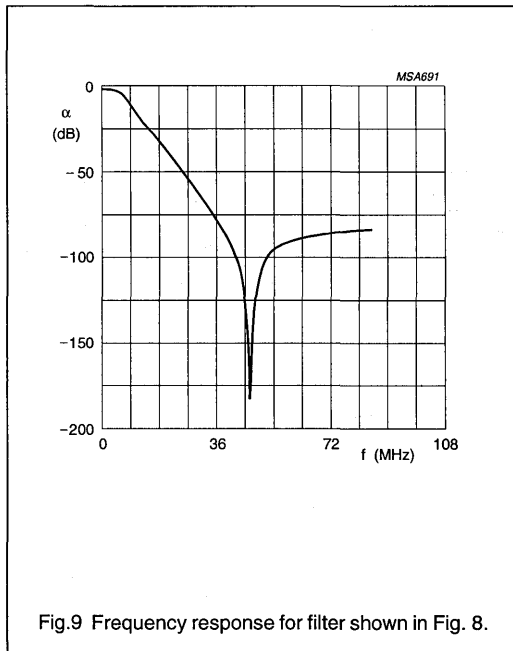
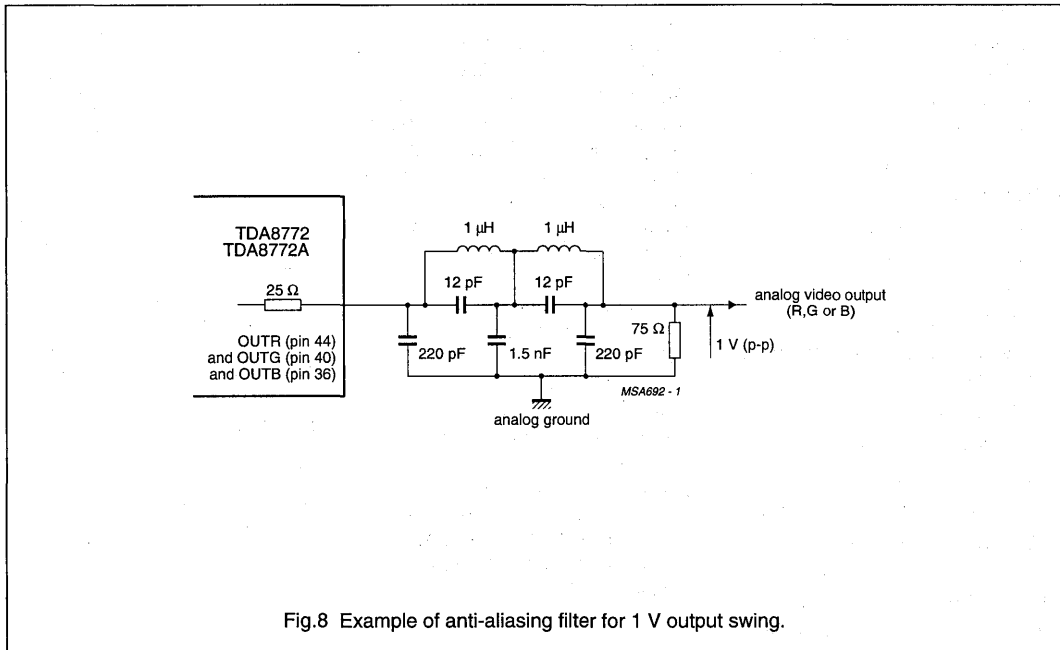

Fig.7 Application diagram.

Triple 8-bit video digital-to-analog converter

TDA8772; TDA8772A



**Characteristics of Fig. 9**

- Order 5; adapted CHEBYSHEV
- Ripple  $\rho \geq 0.6$  dB
- $f$  at  $-3$  dB = 6.5 MHz
- $f_{\text{NOTCH}} = 46$  MHz.

# PAL/NTSC/SECAM decoder/sync processor

## TDA9141

### FEATURES

- Multistandard PAL, NTSC and SECAM
- I<sup>2</sup>C-bus controlled
- I<sup>2</sup>C-bus addresses can be selected by hardware
- Alignment free
- Few external components
- Designed for use with baseband delay lines
- Integrated video filters
- CVBS or YC input with automatic detection
- CVBS output
- Vertical divider system
- Two-level sandcastle signal
- V<sub>A</sub> synchronization pulse (3-state)
- H<sub>A</sub> synchronization pulse or clamping pulse CLP input/output
- Line-locked clock output or stand-alone I<sup>2</sup>C-bus output port
- Stand-alone I<sup>2</sup>C-bus input/output port
- Colour matrix and fast YUV switch
- Comb filter enable input/output with subcarrier frequency.

### GENERAL DESCRIPTION

The TDA9141 is an I<sup>2</sup>C-bus controlled, alignment-free PAL/NTSC/SECAM decoder/sync processor. The TDA9141 has been designed for use with baseband chrominance delay lines, and has a combined subcarrier frequency/comb filter enable signal for communication with a PAL comb filter.

The IC can process CVBS signals and Y/C input signals. The input signal is available on an output pin, in the event of a Y/C signal, it is added into a CVBS signal.

The sync processor provides a two-level sandcastle, a horizontal pulse (CLP or H<sub>A</sub> pulse, bus selectable) and a vertical (V<sub>A</sub>) pulse. When the H<sub>A</sub> pulse is selected a line-locked clock (LLC) signal is available at the output port pin.

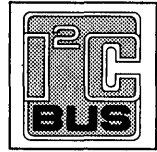

A fast switch can select either the internal Y signal with the UV input signals, or YUV signals made of the RGB input signals. The RGB input signals can be clamped with either the internal or an external clamping signal (search tuning mode). Two pins with an input/output port and an output port of the I<sup>2</sup>C-bus are available.

The I<sup>2</sup>C-bus address of the TDA9141 is hardware programmable.

### ORDERING INFORMATION

EXTENDED TYPE NUMBER	PACKAGE			
	PINS	PIN POSITION	MATERIAL	CODE
TDA9141	32	SDIL	plastic	SOT232

PAL/NTSC/SECAM  
decoder/sync processor

TDA9141

MKA197.1

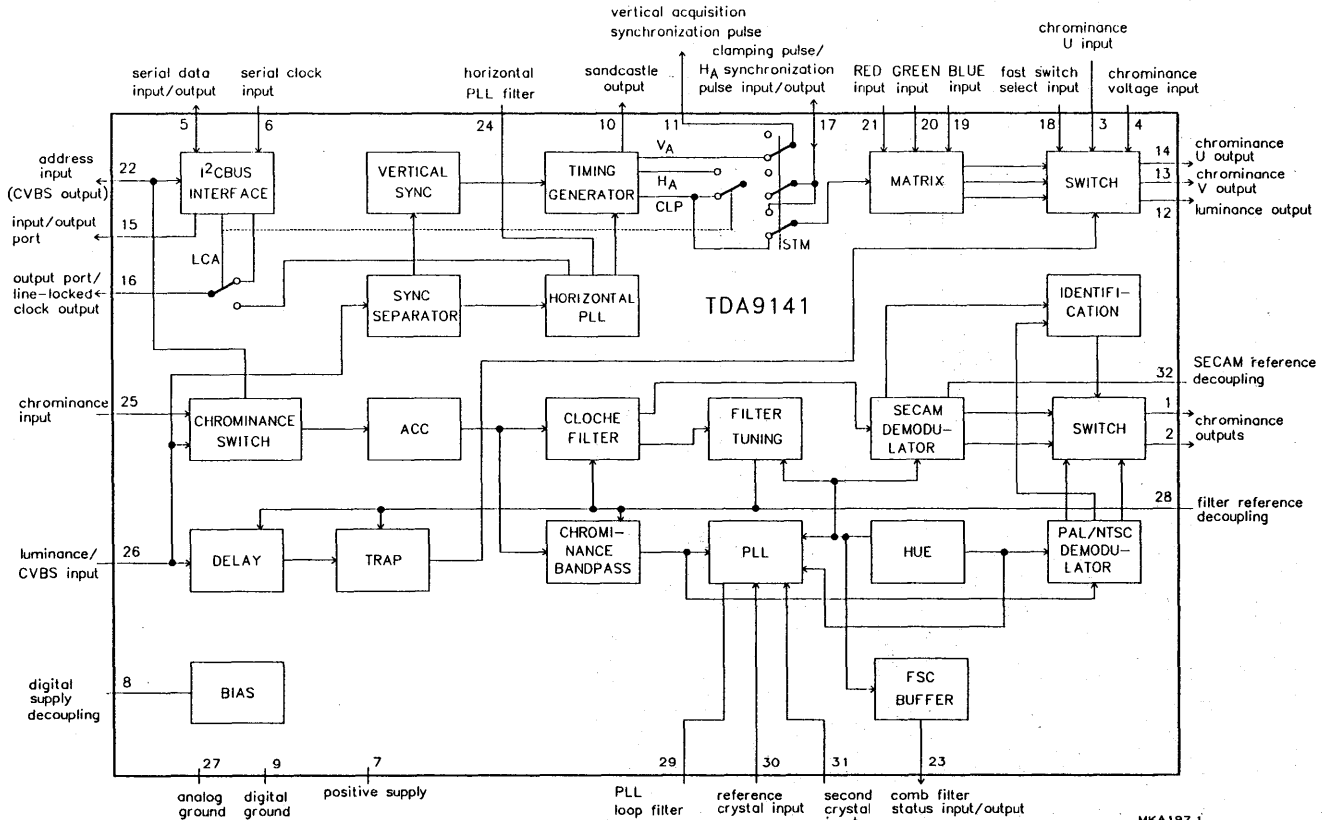

Fig.1 Block diagram.

PAL/NTSC/SECAM  
decoder/sync processor

TDA9141

## QUICK REFERENCE DATA

SYMBOL	PARAMETER	CONDITIONS	MIN.	TYP.	MAX.	UNIT
$V_{CC}$	positive supply voltage		7.2	8.0	8.8	V
$I_{CC}$	supply current		–	45	–	mA
$V_{26(p-p)}$	CVBS input voltage (peak-to-peak value)	top sync - white	–	1.0	–	V
$V_{26(p-p)}$	luminance input voltage (peak-to-peak value)	top sync - white	–	1.0	–	V
$V_{22(p-p)}$	chrominance burst input voltage (peak-to-peak value)		–	0.3	–	V
$V_{12}$	luminance black-white output voltage		–	1.0	–	V
$V_{14(p-p)}$	U output voltage (peak-to-peak value)	standard colour bar	–	1.33	–	V
$V_{13(p-p)}$	V output voltage (peak-to-peak value)	standard colour bar	–	1.05	–	V
$V_{10}$	sandcastle blanking voltage level		–	2.5	–	V
$V_{10}$	sandcastle clamping voltage level		–	4.5	–	V
$V_{11}$	$V_A$ output voltage		–	5.0	–	V
$V_{17}$	$H_A$ output voltage		–	5.0	–	V
$V_{16(p-p)}$	LLC output voltage amplitude (peak-to-peak value)		–	500	–	mV
$V_{21,20,19(p-p)}$	RGB input voltage (peak-to-peak value)	0 to 100% saturation	–	0.7	–	V
$V_{clamp IO}$	clamping pulse input/output voltage		–	5.0	–	V
$V_{sub}$	subcarrier output voltage amplitude (peak-to-peak value)		–	200	–	mV
$V_{15,16}$	O port output voltage		–	5.0	–	V



**PAL/NTSC/SECAM  
decoder/sync processor**

**TDA9141**

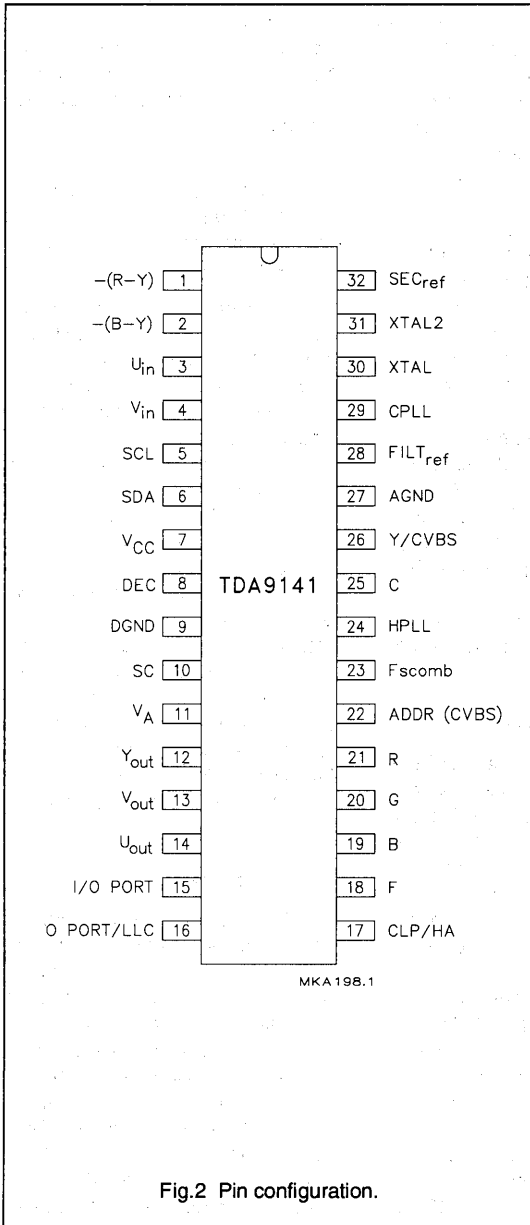

**PINNING**

SYMBOL	PIN	DESCRIPTION
-(R-Y)	1	chrominance output
-(B-Y)	2	chrominance output
U <sub>in</sub>	3	chrominance U input
V <sub>in</sub>	4	chrominance voltage input
SCL	5	serial clock input
SDA	6	serial data input/output
V <sub>CC</sub>	7	positive supply input
DEC	8	digital supply decoupling
DGND	9	digital ground
SC	10	sandcastle output
V <sub>A</sub>	11	vertical acquisition synchronization pulse
Y <sub>out</sub>	12	luminance output
V <sub>out</sub>	13	chrominance V output
U <sub>out</sub>	14	chrominance U output
I/O PORT	15	input/output port
O PORT/LLC	16	output port/line-locked clock output
CLP/HA	17	clamping pulse/H <sub>A</sub> synchronization pulse input/output
F	18	fast switch select input
B	19	BLUE input
G	20	GREEN input
R	21	RED input
ADDR (CVBS)	22	I <sup>2</sup> C-bus address input (CVBS output)
Fscomb	23	comb filter status input/output
HPLL	24	horizontal PLL filter
C	25	chrominance input
Y/CVBS	26	luminance/CVBS input
AGND	27	analog ground
FILT <sub>ref</sub>	28	filter reference decoupling
CPLL	29	colour PLL filter
XTAL	30	reference crystal input
XTAL2	31	second crystal input
SEC <sub>ref</sub>	32	SECAM reference decoupling

# PAL/NTSC/SECAM decoder/sync processor

TDA9141

## FUNCTIONAL DESCRIPTION

### General

The TDA9141 is an I<sup>2</sup>C-bus controlled, alignment-free PAL/NTSC/SECAM colour decoder/sync processor which has been designed for use with baseband chrominance delay lines. In the standard operating mode the I<sup>2</sup>C-bus address is 8A. If the address input is connected to the positive rail the address will change to 8E.

### Input switch

**WARNING: THE VOLTAGE ON THE CHROMINANCE PIN MUST NEVER EXCEED 5.5 V. IF IT DOES THE IC ENTERS A TEST MODE.**

The TDA9141 has a two pin input for CVBS or YC signals which can be selected via the I<sup>2</sup>C-bus. The input selector also has a position in which it automatically detects whether a CVBS or YC signal is on the input. In this input selector position, standard identification first takes place on an added Y/CVBS and C input signal. After that, both chrominance signal input amplitudes are checked once and the input with the strongest chrominance burst signal is selected. The input switch status is read out by the I<sup>2</sup>C-bus via output bit YC.

### CVBS output

In the standard operating mode with the I<sup>2</sup>C-bus address 8A, a CVBS output signal is available on the address pin, which represents either the CVBS input signal or the Y/C input signal, added into a CVBS signal

### RGB colour matrix

**WARNING: THE VOLTAGE ON THE U<sub>IN</sub> PIN MUST NEVER EXCEED 5.5 V. IF IT DOES THE IC ENTERS A TEST MODE.**

The TDA9141 has a colour matrix to convert RGB input signals into YUV signals. A fast switch, controlled by the signal on pin F and enabled by the I<sup>2</sup>C-bus via EFS (enable fast switch), can select between these YUV signals and the YUV signals of the decoder. The Y signal is internally connected to the switch. The  $-(R-Y)$  and  $-(B-Y)$  output signals of the decoder have to first be delayed in external baseband chrominance delay lines. The outputs of the delay lines must be connected to the UV input pins. If the RGB signals are not synchronous with the selected decoder input signal, clamping of the RGB input signals is possible by I<sup>2</sup>C-bus selection of STM (search tuning mode), EFS and by feeding an external clamping signal to the CLP pin.

Also in search tuning mode the VA output will be in a high impedance OFF-state.

### Standard identification

The standards which the TDA9141 can decode are dependent on the choice of external crystals. If a 4.4 MHz and a 3.6 MHz crystal are used then SECAM, PAL 4.4/3.6 and NTSC 4.4/3.6 can be decoded. If two 3.6 MHz crystals are used then only PAL 3.6 and NTSC 3.6 can be decoded. Which 3.6 MHz standards can be decoded is dependent on the exact frequencies of the 3.6 MHz crystals. In an application where not all standards are required only one crystal is sufficient (in this instance the crystal must be connected to the reference crystal input (pin 30)). If a 4.4 MHz crystal is used it must always be connected to pin 30. Both crystals are used to provide a reference for the filters and the horizontal PLL, however, only the reference crystal is used to provide a reference for the SECAM

demodulator.

To enable the calibrating circuits to be adjusted exactly two bits from I<sup>2</sup>C-bus subaddress 00 are used to indicate which crystals are connected to the IC.

The standard identification circuit is a digital circuit without external components; the search loop is illustrated in Fig.3.

The decoder (via the I<sup>2</sup>C-bus) can be forced to decode either SECAM or PAL/NTSC (but not PAL or NTSC). Crystal selection can also be forced. Information concerning which standard and which crystal have been selected and whether the colour killer is ON or OFF is provided by the read out. Using the forced-mode does not affect the search loop, it does, however, prevent the decoder from reaching or staying in an unwanted state. The identification circuit skips impossible standards (e.g. SECAM when no 4.4 MHz crystal is fitted) and illegal standards (e.g. is forced mode). To reduce the risk of wrong identification PAL has priority over SECAM (only line identification is used for SECAM).

### Integrated filters

All filters, including the luminance delay line, are an integral part of the IC. The filters are gyrator-capacitor type filters. The resonant frequency of the filters is controlled by a circuit that uses the active crystal to tune the SECAM Cloche filter during the vertical flyback time. The remaining filters and the luminance delay line are matched to this filter. The filters can be switched to either 4.43 MHz, 4.28 MHz or 3.58 MHz irrespective of the frequency of the active crystal. The switching is controlled by the identification circuit. In YC mode the chrominance notch filter is bypassed, to preserve full

# PAL/NTSC/SECAM decoder/sync processor

TDA9141

signal bandwidth.

For a CVBS signal the chrominance notch filter can be bypassed by I<sup>2</sup>C-bus selection of TB (trap bypass).

The luminance delay line delivers the Y signal to the output 60 ns after the  $-(R-Y)$  and  $-(B-Y)$  signals have arrived at their outputs. This compensates for the delay of the external chrominance delay lines.

## Colour decoder

The PAL/NTSC demodulator employs an oscillator that can operate with either crystal (3.6 or 4.4 MHz). If the I<sup>2</sup>C-bus indicates that only one crystal is connected it will always connect to the crystal on the reference crystal input (pin 30).

The Hue signal, which is adjustable via the I<sup>2</sup>C-bus, is gated during the burst for NTSC signals.

The SECAM demodulator is an auto-calibrating PLL demodulator which has two references. The reference crystal, to force the PLL to the desired free-running frequency and the bandgap reference, to obtain the correct absolute value of the output signal. The VCO of the PLL is calibrated during each vertical blanking period, when the IC is in search mode or SECAM mode. If the reference crystal is not 4.4 MHz the decoder will not produce the correct SECAM signals.

The frequency of the active crystal is fed to the Fscomb output, which can be connected to an external comb filter IC. The DC value on this pin contains the comb enable information. Comb enable is true when bus bit ECMB is HIGH. If ECMB is LOW, the subcarrier frequency is suppressed. The external comb filter can force the DC value of Fscomb LOW, as pin Fscomb also acts as input pin. In this event the subcarrier frequency

is still present. If the DC value of Fscomb is HIGH, the input switch is always forced in Y/C mode, indicated by bus bit YC.

## Sync processor ( $\phi$ 1 loop)

The main part of the sync circuit is a  $432 \times f_H$  (6.75 MHz) oscillator the frequency of which is divided by 432 to lock the Phase 1 loop to the incoming signal. The time constant of the loop can be forced by the I<sup>2</sup>C-bus (fast or slow). If required the IC can select the time constant, depending on the noise content of the input signal and whether the loop is phase-locked or not (medium or slow). The free-running frequency of the oscillator is determined by a digital control circuit that is locked to the active crystal.

When a power-on-reset pulse is detected the frequency of the oscillator is switched to a frequency greater than 6.75 MHz to protect the horizontal output transistor. The oscillator frequency is reset to 6.75 MHz when the crystal indication bits have been loaded into the IC. To ensure that this procedure does not fail it is absolutely necessary to send subaddress 00 before subaddress 01. Subaddress 00 contains the crystal indication bits and when subaddress 01 is received the line oscillator calibration will be initiated (for the start-up procedure after power-on reset detection see the I<sup>2</sup>C-bus protocol). The calibration is terminated when the oscillator frequency reaches 6.75 MHz. The oscillator is again calibrated when an out-of-lock condition with the input signal is detected by the coincidence detector. Again the calibration will be terminated when the oscillator frequency reaches 6.75 MHz.

The Phase 1 loop can be opened using the I<sup>2</sup>C-bus. This is to facilitate

On Screen Display (OSD) information. If there is no input signal or a very noisy input signal the phase 1 loop can be opened to provide a stable line frequency and thus a stable picture.

The sync part also delivers a two-level sandcastle signal, which provides a combined horizontal and vertical blanking signal and a clamping pulse for the display section of the TV.

## Vertical divider system

The vertical divider system has a fully integrated vertical sync separator. The divider can accommodate both 50 and 60 Hz systems; it can either locate the field frequency automatically or it can be forced to the desired system via the I<sup>2</sup>C-bus. A block diagram of the vertical divider system is illustrated in Fig.4. The divider system operates at twice the horizontal line frequency. The line counter receives enable pulses at this line frequency, thereby counting two pulses per line. A state diagram of the controller is illustrated in Fig.5. Because it is symmetrical only the right hand part will be described.

Depending on the previously found field frequency, the controller will be in one of the COUNT states. When the line counter has counted 488 pulses (i.e. 244 lines of the video input signal) the controller will move to the next state depending on the output of the norm counter. This can be either NORM, NEAR\_NORM or NO\_NORM depending on the position of the vertical sync pulse in the previous fields. When the controller is in the NORM state it generates the vertical sync pulse (VSP) automatically and then, when the line counter is at LC = 626, moves to the WAIT state. In this condition it waits for the next pulse

# PAL/NTSC/SECAM decoder/sync processor

TDA9141

of the double line frequency signal and then moves to the COUNT state of the current field frequency. When the controller returns to the COUNT state the line counter will be reset half a line after the start of the vertical sync pulse of the video input signal.

When the controller is in the NEAR\_NORM state it will move to the COUNT state if it detects the vertical sync pulse within the NEAR\_NORM window (i.e.  $622 < LC < 628$ ). If no vertical sync pulse is detected, the controller will move back to the COUNT state when the line counter reaches  $LC = 628$ . The line counter will then be reset.

When the controller is in the NO\_NORM state it will move to the COUNT state when it detects a vertical sync pulse and reset the line counter. If a vertical sync pulse is not detected before  $LC = 722$  (if the Phase 1 loop is locked in forced mode) it will move to the COUNT

state and reset the line counter. If the Phase 1 loop is not locked the controller will move back to the COUNT state when  $LC = 628$ . The forced mode option keeps the controller in either the left-hand side (60 Hz) or the right-hand side (50 Hz) of the state diagram.

Figure 6 illustrates the state diagram of the norm counter which is an up/down counter that counts up if it finds a vertical sync pulse within the selected window. In the NEAR\_NORM and NORM states the first correct vertical sync pulse after one or more incorrect vertical sync pulses is processed as an incorrect pulse. This procedure prevents the system from staying in the NEAR\_NORM or NORM state if the vertical sync pulse is correct in the first field and incorrect in the second field. If no vertical sync pulse is found in the selected window this will always result in a down pulse for the norm counter.

## Output port and input/output port

Two stand-alone ports are available for external use. These ports are I<sup>2</sup>C-bus controlled, the output port by bus bit OPB and the input/output port by bus bit OPA. Bus bit OPA is an open-drain output, to enable input port functioning. The pin status is read out by bus via output bit IP.

## Sandcastle

Figure 7 illustrates the timing of the acquisition sandcastle (ASC) and the  $V_A$  pulse with respect to the input signal. The sandcastle signal is in accordance with the 2-level 5 V sandcastle format. An external vertical guard current can overrule the sink current to enable blanking purposes.

# PAL/NTSC/SECAM decoder/sync processor

TDA9141

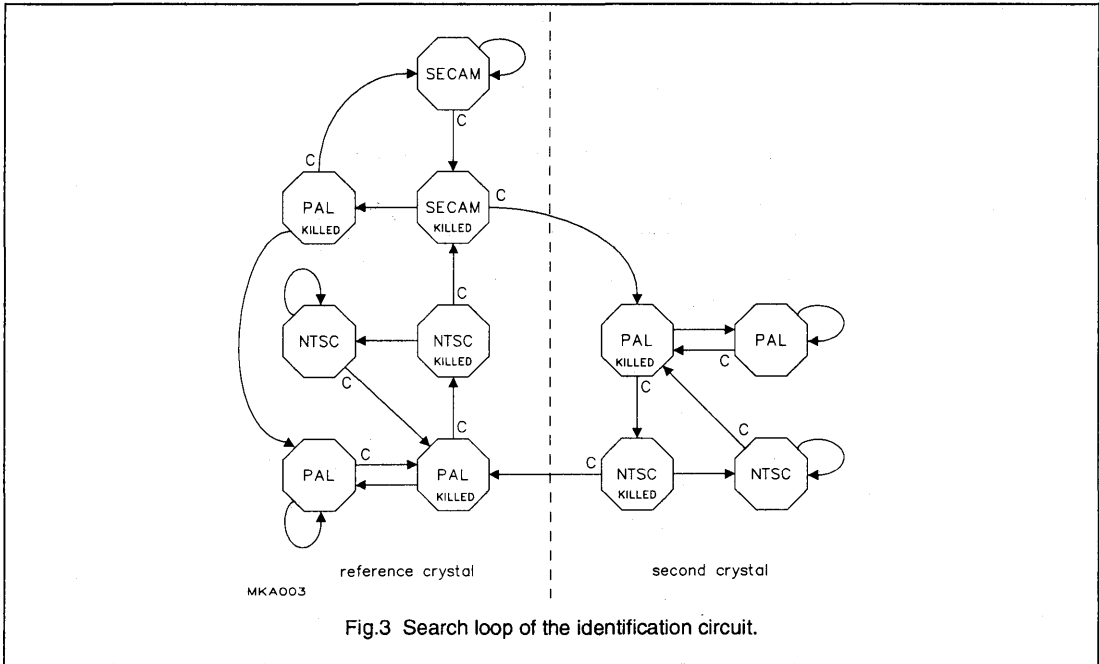

Fig.3 Search loop of the identification circuit.

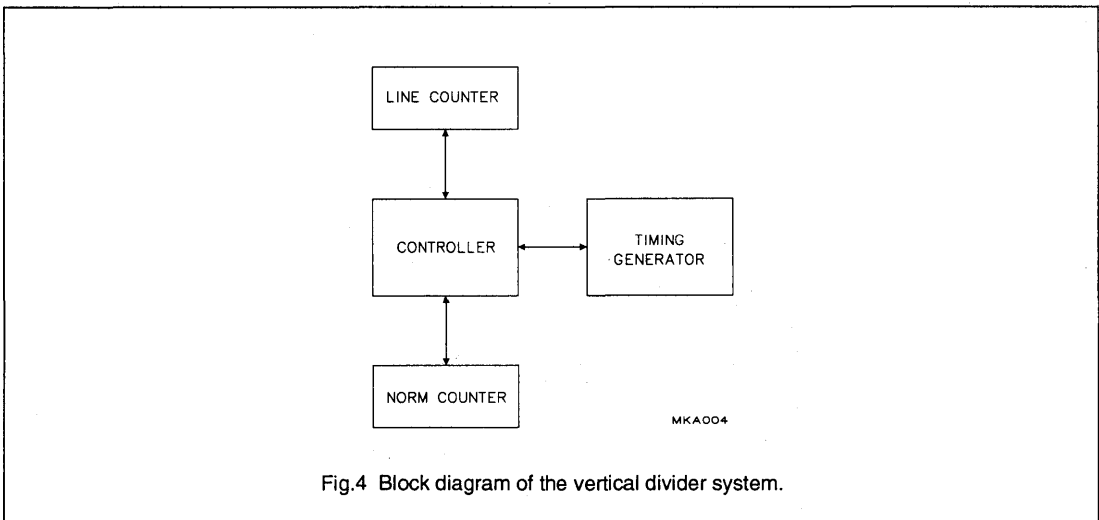
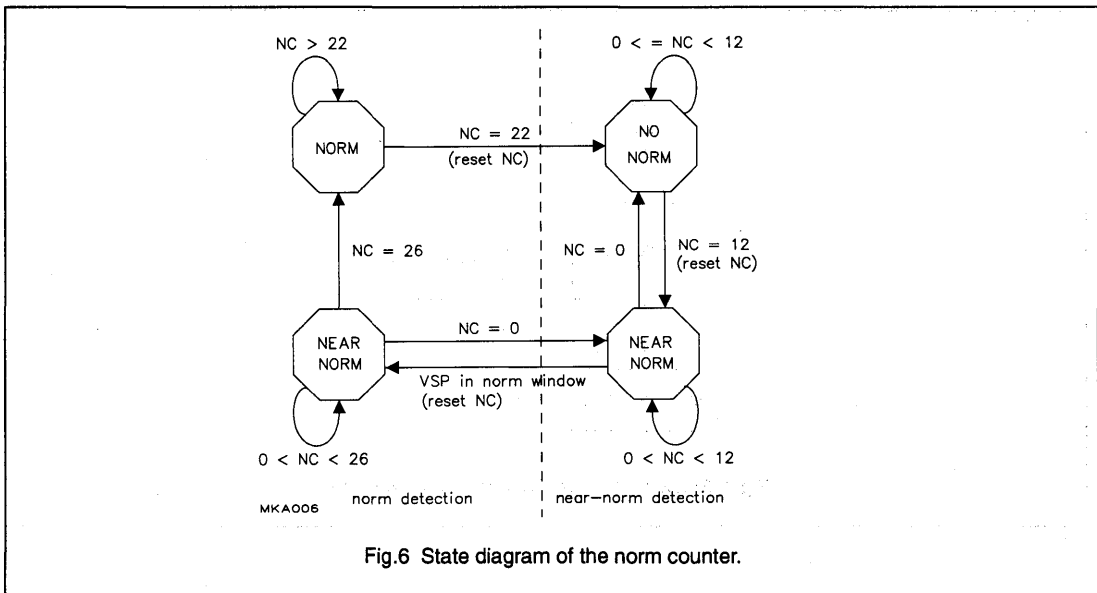
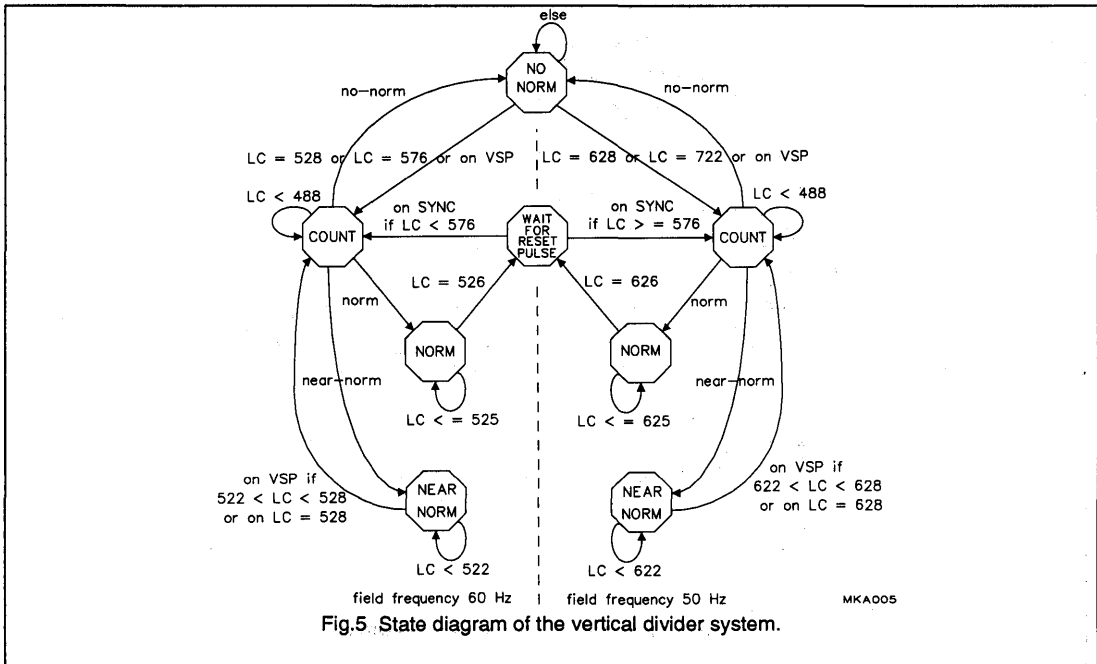

Fig.4 Block diagram of the vertical divider system.

PAL/NTSC/SECAM  
decoder/sync processor

TDA9141



# PAL/NTSC/SECAM decoder/sync processor

## TDA9141

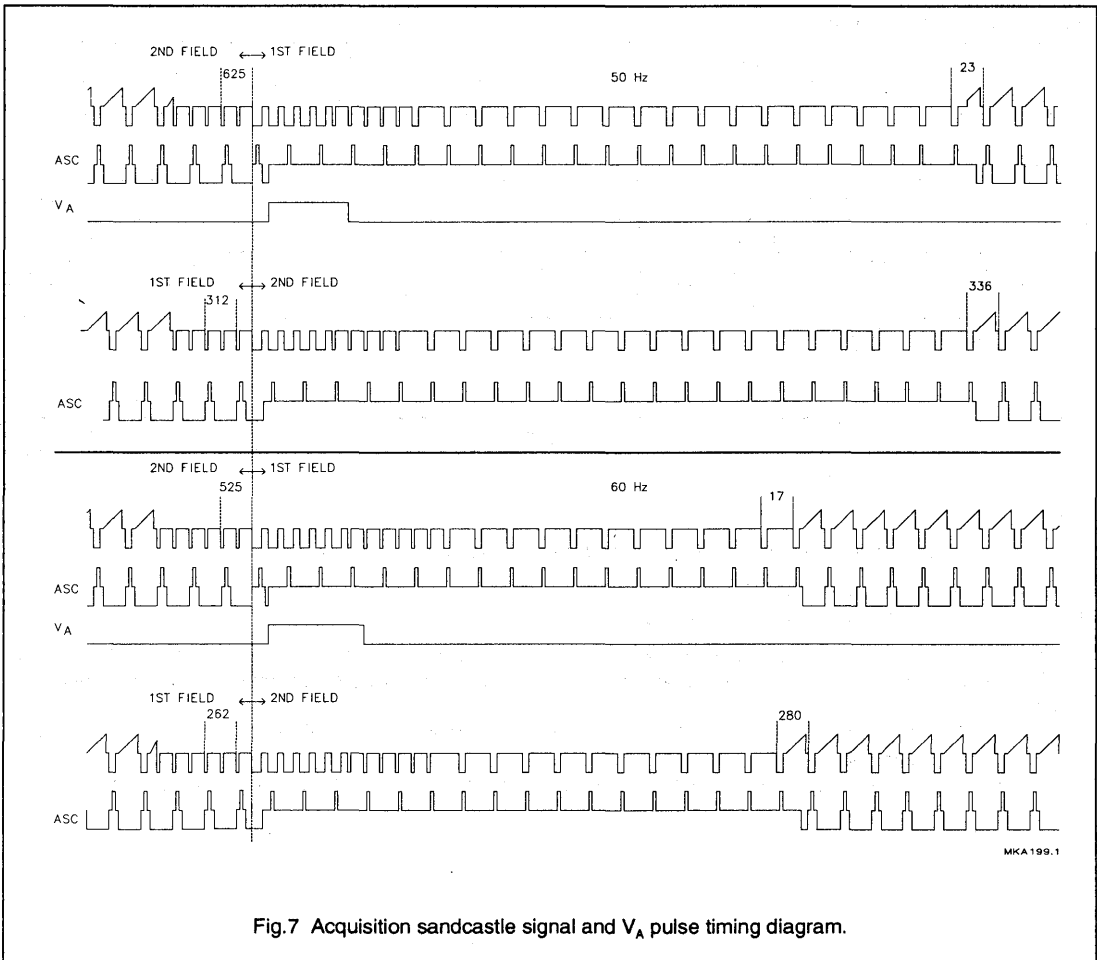

Fig. 7 Acquisition sandcastle signal and  $V_A$  pulse timing diagram.

PAL/NTSC/SECAM  
decoder/sync processor

TDA9141

Table 1 Slave address (8A).

A6	A5	A4	A3	A2	A1	A0	R/W
1	0	0	0	1	X	1	X

Table 2 Inputs.

SUBADDRESS	MSB							LSB
00	INA	INB	TB	ECMB	FOA	FOB	XA	XB
01	FORF	FORS	OPA	OPB	POC	FM	SAF	FRQF
02	EFS	STM	HU5	HU4	HU3	HU2	HU1	HU0
03	LCA	-	-	-	-	-	-	-

Table 3 Outputs.

ADDRESS	POR	FSI	YC	SL	IP	SAK	SBK	FRQ
---------	-----	-----	----	----	----	-----	-----	-----

**I<sup>2</sup>C-bus protocol**

If the address input is connected to the positive supply the address will change from 8A to 8E.

Valid subaddresses = 00 to 0F

Auto-increment mode available for subaddresses.

**Start-up procedure:** read the status byte until POR = 0; send subaddress 00 with the crystal indicator bits (XA and XB) indicating that only one crystal is connected to the IC; wait for 250 ms; send subaddress 01; wait for at least 100 ms; set XA, XB to the actual crystal configuration.

Each time before the data in the IC is refreshed, the status byte must be read. If POR = 1, then the above procedure must be carried out to restart the IC.

Failure to stick to the above procedure may result in an incorrect line frequency after power-up or a power-dip.



# PAL/NTSC/SECAM decoder/sync processor

TDA9141

## INPUT SIGNALS

**Table 4** Source select.

INA	INB	SOURCE
0	0	CVBS
0	1	YC
1	-	auto CVBS/YC

**Table 5** Trap bypass.

TB	CONDITION
0	trap not bypassed
1	trap bypassed

**Table 6** Comb filter enable.

ECMB	CONDITION
0	comb filter disabled
1	comb filter enabled

**Table 7** Phase 1 time constant.

FOA	FOB	MODE
0	0	auto
0	1	slow
1	-	fast

**Table 8** Crystal indication.

XA	XB	CRYSTAL
0	0	2 x 3.6 MHz
0	1	1 x 3.6 MHz
1	0	1 x 4.4 MHz
1	1	3.6 and 4.4 MHz

**Table 9** Forced field frequency.

FORF	FORS	FIELD FREQUENCY
0	0	auto; 60 Hz if no lock
0	1	60 Hz
1	0	50 Hz
1	1	auto; 50 Hz if no lock

**Table 10** Output value I/O port.

OPA	CONDITION
0	LOW
1	HIGH

**Table 11** Output value O port.

OPB	CONDITION
0	LOW
1	HIGH

**Table 12** Phase 1 loop control.

POC	CONDITION
0	phase one loop closed
1	phase one loop open

**Table 13** Forced standard.

FM	SAF	FRQF	STANDARD
0	-	-	auto search
1	0	0	PAL/NTSC second crystal
1	0	1	PAL/NTSC reference crystal
1	1	0	illegal
1	1	1	SECAM reference crystal

### Note to Table 13

If XA and XB indicate that only one crystal is connected to the IC and FM and FRQF force it to use the second crystal the colour will be switched off.

PAL/NTSC/SECAM  
decoder/sync processor

TDA9141

Table 14 Fast switch enable.

EFS	CONDITION
0	fast switch disabled
1	fast switch enabled

Table 15 Search tuning mode.

STM	CONDITION
0	search tuning mode off
1	search tuning mode on

Table 16 Hue.

FUNCTION	ADDRESS	DIGITAL NUMBER
hue	HU5 to HU0	000000 = -45 ° 111111 = +45 °

Table 17 Line-locked clock active.

LCA	CONDITION
0	OPB/CLP mode
1	LLC/HA mode

## OUTPUT SIGNALS

Table 18 Power-on reset.

POR	CONDITION
0	normal mode
1	power-down mode

Table 19 Field frequency indication.

FSI	CONDITION
0	50 Hz
1	60 Hz

Table 20 Input switch mode.

YC	CONDITION
0	CVBS mode
1	YC mode

Table 21 Phase 1 lock indication.

SL	CONDITION
0	not locked
1	locked

Table 22 Input value I/O port.

IP	CONDITION
0	LOW
1	HIGH

Table 23 Standard read-out.

SAK	SBK	FRQ	STANDARD
0	0	0	PAL second crystal
0	0	1	PAL reference crystal
0	1	0	NTSC second crystal
0	1	1	NTSC reference crystal
1	0	0	illegal forced mode
1	0	1	SECAM reference crystal
1	1	-	colour off

**PAL/NTSC/SECAM  
decoder/sync processor**

TDA9141

**LIMITING VALUES**

In accordance with the Absolute Maximum Rating System. (IEC134)

SYMBOL	PARAMETER	CONDITIONS	MIN.	MAX.	UNIT
$V_{CC}$	positive supply voltage		-	8.8	V
$I_{CC}$	supply current		-	60	mA
$P_{tot}$	total power dissipation		-	530	mW
$T_{stg}$	storage temperature		-55	+150	°C
$T_{amb}$	operating ambient temperature		-10	+65	°C
ESD	electrostatic discharge (on all pins)				
	Human body model	note 1	-2000	+2000	V
	Machine model	note 2	-200	+200	V

**Notes to the limiting values**

1. Equivalent to discharging a 100 pF capacitor via a 1.5 k $\Omega$  series resistor.
2. Equivalent to discharging a 200 pF capacitor via a 0  $\Omega$  series resistor.

**THERMAL RESISTANCE**

SYMBOL	PARAMETER	THERMAL RESISTANCE
$R_{th\ j-a}$	from junction to ambient in free air	48 K/W

PAL/NTSC/SECAM  
decoder/sync processor

TDA9141

**CHARACTERISTICS** $V_{CC} = 8\text{ V}$ ;  $T_{amb} = 25\text{ }^{\circ}\text{C}$ ; unless otherwise specified.

SYMBOL	PARAMETER	CONDITIONS	MIN.	TYP.	MAX.	UNIT
<b>Supply</b>						
$V_{CC}$	positive supply voltage		7.2	8.0	8.8	V
$I_{CC}$	supply current		–	45	–	mA
$P_{tot}$	total power dissipation		–	360	–	mW
<b>Input switch</b>						
Y/CVBS INPUT (PIN 26)						
$V_{26(p-p)}$	input voltage (peak-to-peak value)	top sync - white	–	1.0	1.43	V
$Z_1$	input impedance		60	–	–	k $\Omega$
C INPUT (PIN 25)						
$V_{25(p-p)}$	input burst voltage (peak-to-peak value)		–	0.3	0.43	V
$Z_1$	input impedance		60	–	–	k $\Omega$
CVBS OUTPUT (PIN 22) ONLY ADDRESS 8A						
$V_{22(p-p)}$	output voltage (peak-to-peak value)	top sync - white	–	1.0	–	V
$Z_O$	output impedance		–	–	500	$\Omega$
$V_{tsl}$	top sync voltage level		–	2.8	–	V
<b>Bias generator (pin 8)</b>						
$V_8$	digital supply voltage		–	5.0	–	V
<b>Subcarrier regeneration</b>						
GENERAL						
CR	catching range reference crystal 4.4 MHz reference crystal 3.6 MHz second crystal 3.6 MHz	note 1	$\pm 400$ tbf $\pm 300$	– – –	– – –	Hz Hz Hz
$\varphi$	phase shift for 400 Hz deviation for 300 Hz deviation	4.4 MHz 3.6 MHz	– –	– –	5 5	deg deg
TC	temperature coefficient of oscillator		–	tbf	–	Hz/K
$Z_1$	input impedance reference crystal input second crystal input		– –	1.0 1.5	– –	k $\Omega$ k $\Omega$
$V_{dep}$	supply voltage dependency		–	tbf	–	V
FSCOMB OUTPUT (PIN 23)						
$V_{sub(p-p)}$	subcarrier output amplitude (peak-to-peak value)	$C_L = 15\text{ pF}$	150	200	300	mV
$V_{cen}$	comb enable voltage level		4.0	4.2	–	V
$V_{cds}$	comb disable voltage level		–	0.8	1.4	V

PAL/NTSC/SECAM  
decoder/sync processor

TDA9141

SYMBOL	PARAMETER	CONDITIONS	MIN.	TYP.	MAX.	UNIT
$I_{\text{sink}}$	minimum sink current to force output to comb disable level		0.4	–	2.0	mA
$R_{\text{GND}}$	value of grounded resistor to force output to comb disable level		0.4	–	2.0	k $\Omega$
<b>ACC</b>						
	ACC control range		–20	–	+5	dB
	change of $-(R-Y)$ and $-(B-Y)$ signals over ACC range		–	–	1	dB
	colour killer threshold		–	–25	–	dB
	PAL/NTSC		–	–23	–	dB
	SECAM		–	–23	–	dB
	kill - unkill hysteresis		–	3	–	dB
<b>Demodulators <math>-(R-Y)</math> and <math>-(B-Y)</math> outputs (pins 1 and 2)</b>						
	ratio of $-(R-Y)$ and $-(B-Y)$ signals	standard colour bar	1.20	1.27	1.34	
TC	temperature coefficient of $-(R-Y)$ and $-(B-Y)$ amplitude		–	tbf	–	Hz/K
	spread of $-(R-Y)$ and $-(B-Y)$ ratio between standards		–1	–	+1	dB
$V_1$	output level of $-(R-Y)$ during blanking		–	2.0	–	V
$V_2$	output level of $-(B-Y)$ during blanking		–	2.0	–	V
B	–3 dB bandwidth		–	1	–	MHz
$Z_o$	output impedance		–	–	500	$\Omega$
$V_{\text{dep}}$	supply voltage dependency		–	tbf	–	V
<b>PAL/NTSC DEMODULATOR</b>						
$V_{1(p-p)}$	$-(R-Y)$ output voltage (peak-to-peak value)	standard colour bar	470	525	585	mV
$V_{2(p-p)}$	$-(B-Y)$ output voltage (peak-to-peak value)	standard colour bar	595	665	740	mV
$\alpha$	crosstalk between $-(R-Y)$ and $-(B-Y)$		–	tbf	–	dB
$V_{1.2(p-p)}$	8.8 MHz residue (peak-to-peak value)	both outputs	–	–	15	mV
$V_{1.2(p-p)}$	7.2 MHz residue (peak-to-peak value)	both outputs	–	–	20	mV
<b>PAL DEMODULATOR</b>						
$V_{R(p-p)}$	H/2 ripple (peak-to-peak value)		–	–	50	mV
S/N	signal-to-noise ratio		46	–	–	dB
<b>NTSC DEMODULATOR</b>						
$\varphi$	hue phase shift		–	$\pm 45$	–	deg
<b>SECAM DEMODULATOR</b>						
$V_{1(p-p)}$	$-(R-Y)$ output voltage (peak-to-peak value)	standard colour bar	0.94	1.05	1.17	V
$V_{2(p-p)}$	$-(B-Y)$ output voltage (peak-to-peak value)	standard colour bar	1.19	1.33	1.48	V
$f_{\text{os}}$	black level offset		–	–	7	kHz
S/N	signal-to-noise ratio		–	43	–	dB

PAL/NTSC/SECAM  
decoder/sync processor

TDA9141

SYMBOL	PARAMETER	CONDITIONS	MIN.	TYP.	MAX.	UNIT
$V_{res(p-p)}$	7.8 to 9.4 MHz residue (peak-to-peak value)		–	–	30	mV
$f_{pole}$	pole frequency of deemphasis		77	85	93	kHz
	ratio of pole and zero frequency		–	3	–	
$V_{cal}$	calibration voltage		3	4	5	V
NL	non linearity		–	–	3	%
<b>Filters</b>						
TUNING						
$V_{tune}$	tuning voltage		1.5	3.0	6.0	V
LUMINANCE DELAY						
$t_d$	delay time					
	PAL/NTSC		–	480	–	ns
	SECAM		–	480	–	ns
	B/W		–	220	–	ns
CHROMINANCE TRAP						
$f_o$	notch frequency					
		$f_{sc} = 3.6$ MHz	3.53	3.58	3.63	MHz
		$f_{sc} = 4.4$ MHz	4.37	4.43	4.49	MHz
		SECAM	4.23	4.29	4.35	MHz
		YC mode; not active				
B	bandwidth at –3 dB					
		$f_{sc} = 3.6$ MHz	–	2.5	–	MHz
		$f_{sc} = 4.4$ MHz	–	3.1	–	MHz
		SECAM	–	3.0	–	MHz
SUPP	subcarrier suppression		26	–	–	dB
CHROMINANCE BANDPASS						
$f_{res}$	resonant frequency					
		$f_{sc} = 3.6$ MHz	–	3.58	–	MHz
		$f_{sc} = 4.4$ MHz	–	4.43	–	MHz
B	bandwidth at –3 dB					
		$f_{sc} = 3.6$ MHz	–	1.4	–	MHz
		$f_{sc} = 4.4$ MHz	–	1.7	–	MHz
CLOCHE FILTER						
$f_{res}$	resonant frequency	SECAM	4.26	4.29	4.31	MHz
B	bandwidth at –3 dB	SECAM	241	268	295	kHz

PAL/NTSC/SECAM  
decoder/sync processor

TDA9141

SYMBOL	PARAMETER	CONDITIONS	MIN.	TYP.	MAX.	UNIT
<b>Sync input</b>						
VIDEO INPUT						
$V_{26}$	sync pulse amplitude	Y/CVBS input	50	300	600	mV
	slicing level		–	50	–	%
$t_d$	delay of sync pulse due to internal filter		0.2	0.3	0.4	$\mu$ s
S/N	noise detector threshold level		–	20	–	dB
H	hysteresis		–	3	–	dB
$t_d$	delay between video signal and internally separated vertical sync pulse		12	18.5	27	$\mu$ s
<b>Horizontal section</b>						
CLP OUTPUT (OPB/CLP MODE); $H_A$ OUTPUT (LLC/HA MODE)						
$V_{OH}$	HIGH level output voltage		4.0	5.0	5.5	V
$V_{OL}$	LOW level output voltage	$I_{sink} = 2$ mA	–	0.2	0.4	V
$I_{sink}$	sink current		2	–	–	mA
$I_{source}$	source current		2	–	–	mA
$t_W$	$H_A$ pulse width (32 LLC pulses)		–	4.7	–	$\mu$ s
$t_d$	delay between middle of horizontal sync pulse and middle of $H_A$	note 2	0.3	0.45	0.6	$\mu$ s
$t_d$	delay between negative edge LLC pulse and positive edge $H_A$ pulse	$C_L = 15$ pF	10	20	40	ns
$t_W$	CLP pulse width	21 LLC pulses	–	3.1	–	$\mu$ s
$t_d$	delay between middle of horizontal sync pulse and start of CLP pulse	note 2	3.5	3.7	3.9	$\mu$ s
FIRST LOOP						
$\Delta f$	frequency deviation when not locked		–	–	1.5	%
SVRR	supply voltage ripple rejection		–	tbf	–	V
TC	temperature coefficient		–	tbf	–	Hz/ $^{\circ}$ C
$f_{CR}$	catching range		$\pm 625$	–	–	Hz
$f_{HR}$	holding range		–	–	$\pm 1.4$	kHz
$\phi$	static phase shift		–	–	0.1	$\mu$ s/kHz
LLC OUTPUT (LLC/ $H_A$ MODE)						
$f_o$	output frequency					
	432 $f_H$	50 Hz standard	–	6.75	–	MHz
	432 $f_H$	60 Hz standard	–	6.80	–	MHz
$V_{O(p-p)}$	output amplitude (peak-to-peak value)	$C_L = 15$ pF	0.25	–	–	V
$V_o$	DC output voltage level		–	2.5	–	V

PAL/NTSC/SECAM  
decoder/sync processor

TDA9141

SYMBOL	PARAMETER	CONDITIONS	MIN.	TYP.	MAX.	UNIT
<b>Vertical section</b>						
VERTICAL OSCILLATOR						
$f_{fr}$	free running frequency	FORF = 1; divider ratio 628	–	50	–	Hz
		FORF = 0; divider ratio 528	–	60	–	Hz
$f_{LR}$	frequency locking range		43	–	64	Hz
LR	divider locking range		488	625	722	
<b>V<sub>A</sub> output</b>						
V <sub>OH</sub>	HIGH level output voltage		4.0	5.0	5.5	V
V <sub>OL</sub>	LOW level output voltage		–	0.2	0.4	V
I <sub>sink</sub>	sink current		2	–	–	mA
I <sub>source</sub>	source current		2	–	–	mA
t <sub>w</sub>	V <sub>A</sub> pulse width	50 Hz standard	–	160	–	μs
		60 Hz standard	–	192	–	μs
t <sub>d</sub>	delay between start of vertical sync pulse and positive edge of V <sub>A</sub> pulse		–	32	–	μs
Z <sub>O</sub>	output impedance	STM = 1	3	–	–	MΩ
<b>Sandcastle output (pin 10)</b>						
V <sub>10</sub>	zero level output voltage		0	0.5	1.0	V
I <sub>sink</sub>	sink current		0.5	–	–	mA
HORIZONTAL AND VERTICAL BLANKING						
V <sub>bl</sub>	blanking voltage level		2.0	2.5	3.0	V
I <sub>source</sub>	source current		0.5	–	–	mA
I <sub>ext</sub>	external current required to force the output to the blanking level		1.0	–	3.0	mA
t <sub>w</sub>	horizontal blanking pulse width	69 LLC pulses	–	10.2	–	μs
t <sub>d</sub>	delay between start of horizontal blanking and start of clamping pulse	45 LLC pulses	–	6.7	–	μs
CLAMPING PULSE						
V <sub>clamp</sub>	clamping voltage level		4.0	4.5	5.0	V
I <sub>source</sub>	source current		0.5	–	–	mA
t <sub>w</sub>	pulse width	21 LLC pulses	–	3.1	–	μs
t <sub>d</sub>	delay between middle sync of input and start of clamping pulse	note 2	3.5	3.7	3.9	μs



PAL/NTSC/SECAM  
decoder/sync processor

TDA9141

SYMBOL	PARAMETER	CONDITIONS	MIN.	TYP.	MAX.	UNIT
<b>Colour matrix</b>						
$G_v$	gain					
	from R to Y		–	0.43	–	
	from G to Y		–	0.84	–	
	from B to Y		–	0.16	–	
	from R to $U_{out}$		–	0.43	–	
	from G to $U_{out}$		–	0.84	–	
	from B to $U_{out}$		–	1.27	–	
	from R to $V_{out}$		–	1.00	–	
	from G to $V_{out}$		–	0.84	–	
from B to $V_{out}$		–	0.16	–		
<b>Output and input/output port</b>						
<b>O PORT (OPB/CLP MODE)</b>						
$V_{OH}$	HIGH level output voltage		4.0	5.0	5.5	V
$V_{OL}$	LOW level output voltage		–	0.2	0.4	V
$I_{sink}$	sink current		100	–	–	$\mu$ A
$I_{source}$	source current		100	–	–	$\mu$ A
<b>I/O PORT (OPB/CLP MODE)</b>						
$V_{OH}$	HIGH level output voltage		–	–	$V_{SUP}$	V
$V_{OL}$	LOW level output voltage		–	0.2	0.4	V
$I_{sink}$	sink current		2	–	–	mA
$V_{IH}$	HIGH level input voltage		2.0	–	–	V
$V_{IL}$	LOW level input voltage		–	–	0.6	V
<b>YUV switches (note 3)</b>						
<b>RGB INPUTS (NOTE 3)</b>						
$V_{I(p-p)}$	input voltage (peak-to-peak value)	note 4	–	0.7	1.0	V
$Z_i$	input impedance		3	–	–	M $\Omega$
<b>UV INPUTS (NOTE 3)</b>						
$V_{I(p-p)}$	U input voltage (peak-to-peak value)	note 3	–	1.33	1.90	V
$V_{I(p-p)}$	V input voltage (peak-to-peak value)		–	1.05	1.50	V
$Z_i$	input impedance (both inputs)		3	–	–	M $\Omega$
<b>Y OUTPUT</b>						
$V_{O(p-p)}$	U output voltage (peak-to-peak value)	note 4; top sync-to-white	–	1.43	–	V
$Z_o$	output impedance		–	–	250	$\Omega$
$V_o$	DC output voltage level	top sync	–	2.5	–	V
S/N	signal-to-noise ratio		–	tof	–	dB

PAL/NTSC/SECAM  
decoder/sync processor

TDA9141

SYMBOL	PARAMETER	CONDITIONS	MIN.	TYP.	MAX.	UNIT
<b>YUV switches (note 3)</b>						
<b>RGB INPUTS (NOTE 3)</b>						
$V_{I(p-p)}$	input voltage (peak-to-peak value)	note 4	–	0.7	1.0	V
$Z_I$	input impedance		3	–	–	M $\Omega$
<b>UV INPUTS (NOTE 3)</b>						
$V_{U(p-p)}$	U input voltage (peak-to-peak value)	note 3	–	1.33	1.90	V
$V_{V(p-p)}$	V input voltage (peak-to-peak value)		–	1.05	1.50	V
$Z_I$	input impedance (both inputs)		3	–	–	M $\Omega$
<b>Y OUTPUT</b>						
$V_{O(p-p)}$	U output voltage (peak-to-peak value)	note 4; top sync-to-white	–	1.43	–	V
$Z_O$	output impedance		–	–	250	$\Omega$
$V_O$	DC output voltage level	top sync	–	2.5	–	V
S/N	signal-to-noise ratio		–	tbf	–	dB
<b>UV OUTPUTS (NOTE 3)</b>						
$V_{O(p-p)}$	U output voltage (peak-to-peak value)		–	1.33	1.90	V
$V_{O(p-p)}$	V output voltage (peak-to-peak value)		–	1.05	1.50	V
$Z_O$	output impedance (both outputs)		–	–	250	$\Omega$
$V_O$	DC output voltage level		–	2.7	–	V
<b>GENERAL</b>						
$V_{diff}$	difference between black levels of YUV outputs in RGB mode and YUV mode	sync locked	–	–	10	mV
NL	non-linearity	any input to any output	–	–	5	%
B	bandwidth	any input to any output	–	7	–	MHz
CT	crosstalk between RGB and UV <sub>in</sub> signals on UV <sub>out</sub>	f = 0 to 5 MHz	–	–	–50	dB
<b>FAST SWITCH SELECT INPUT (PIN 18)</b>						
$V_{IH}$	HIGH level input voltage	RGB switched on	0.9	–	3.0	V
$V_{IL}$	LOW level input voltage	UV switched on	0	–	0.5	V
$G_V$	gain					
	from U <sub>in</sub> to U <sub>out</sub>		–	1	–	
	from V <sub>in</sub> to V <sub>out</sub>		–	1	–	
$t_d$	switching delay	between pin 18 and YUV	–	–	20	ns

PAL/NTSC/SECAM  
decoder/sync processor

TDA9141

SYMBOL	PARAMETER	CONDITIONS	MIN.	TYP.	MAX.	UNIT
INPUT CLAMP (PIN 17)						
$V_{IH}$	HIGH level input voltage	clamping	2.4	–	5.5	V
$V_{IL}$	LOW level input voltage	no clamping	0	–	0.6	V
$t_W$	clamping pulse width		1.8	3.5	–	$\mu$ s
$V_{os}$	clamping offset voltage on UV outputs		–	–	10	mV
$Z_i$	input impedance	STM = 1	3	–	–	M $\Omega$

### Notes to the characteristics

- All oscillator specifications are measured with the Philips crystal series 4322 143/144. If the spurious response of the reference crystal is less than –3 dB with respect to the fundamental frequency for a damping resistance of 1 k $\Omega$ , oscillation at the fundamental frequency is guaranteed. The spurious response of the second crystal must be less than –3 dB with respect to the fundamental frequency for a damping resistance of 1.5 k $\Omega$ .

The catching and detuning range are measured for nominal crystal parameters. These are:

load resonance frequency  $f_o$  ( $C_L = 20$  pF) = 4.433619 MHz, (second crystal: 3.579545 MHz)

motional capacitance  $C_M = 20.6$  fF, (second crystal: 14.7 fF)

parallel capacitance  $C_o = 5.5$  pF, (second crystal: 4.5 pF).

The actual load capacitance in the application should be  $C_L = 18$  pF to account for parasitic capacitances on and off chip.

- This delay is caused by the low pass filter at the sync separator input.
- The output signals of the demodulator are called –(R–Y) and –(B–Y). The colour difference input and output signals of the YUV switch are called UV signals. However, these signals do not have the amplitude correction factor of real UV signals. They are called UV signals and not –(R–Y) and –(B–Y) to prevent confusion between the colour difference signals of the demodulator and the colour difference signals of the YUV switch.
- This value refers to signals including a sync pulse. For Y signals composed of the RGB inputs this output voltage is 30% lower, as there is no sync pulse on such signals.

**PAL/NTSC/SECAM  
decoder/sync processor**

**TDA9141**

**QUALITY SPECIFICATION**

Quality level in accordance with URV 4-2-59/601.

**TEST AND APPLICATION INFORMATION**

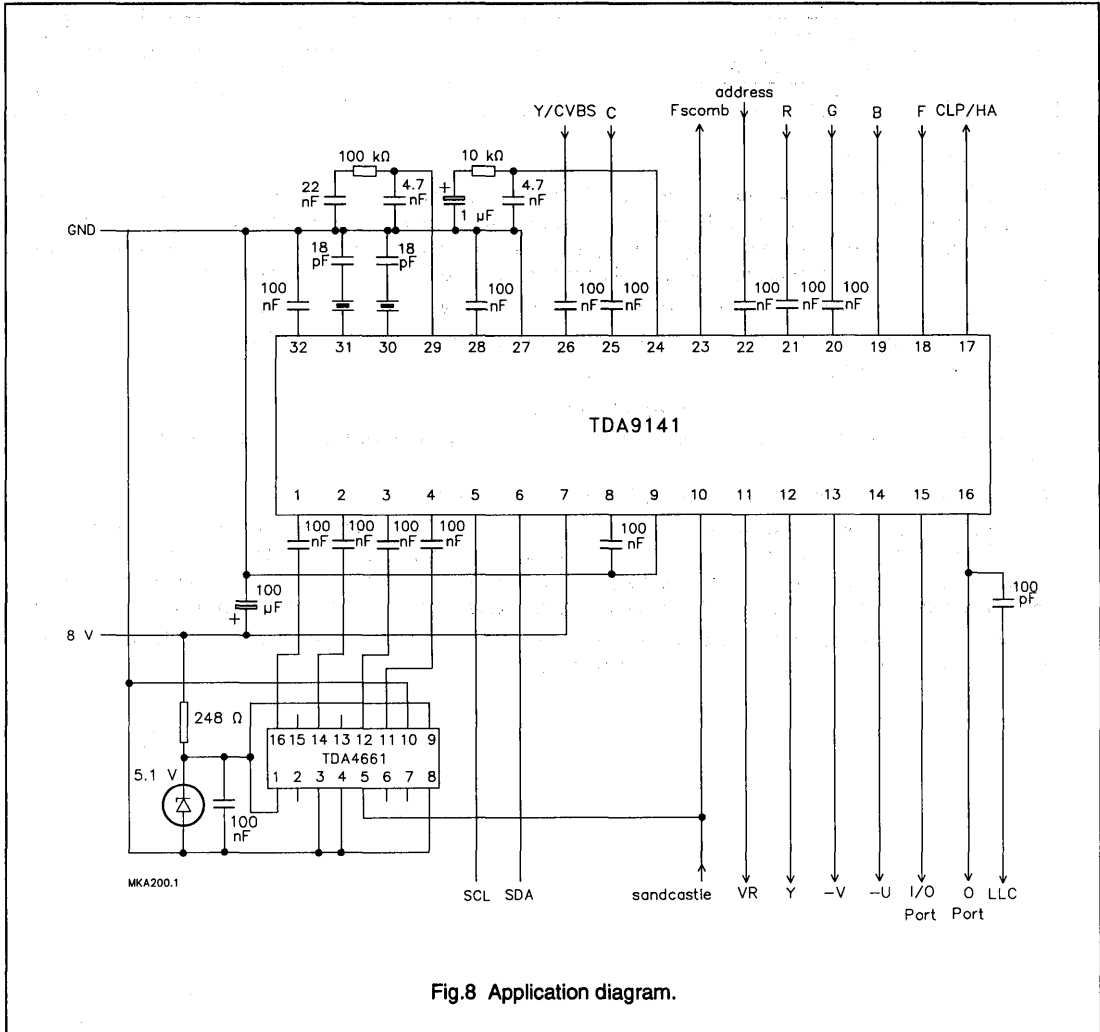

Fig.8 Application diagram.

**Notes to figure 8**

1. Pins 28 and 32 are sensitive to leakage current.
2. The analog and digital ground currents should be completely separated.
3. The decoupling capacitor connected between pins 8 and 9 must be placed as close to the IC as possible.

## 8-bit high-speed analog-to-digital converter

TDF8704

## FEATURES

- 8-bit resolution
- Sampling rate up to 50 MHz
- Extended temperature range (-40 to +85 °C)
- High signal-to-noise ratio over a large analog input frequency range (7.4 effective bits at 4.43 MHz full-scale input and at  $f_{\text{clk}} = 50$  MHz)
- Binary 3-state TTL outputs
- Overflow/underflow 3-state TTL output
- TTL compatible digital inputs
- Low-level AC clock input signal allowed
- Stable internal reference voltage regulator included
- Power dissipation only 380 mW (typical)
- Low analog input capacitance, no buffer amplifier required
- No sample-and-hold circuit required.

## APPLICATIONS

- General purpose high-speed analog-to-digital conversion for extended temperature applications
- Automotive
- RF, satellite and GPS (Global Positioning System)
- Medical
- General industrial
- Digital video (VCR, TV and satellite).

## GENERAL DESCRIPTION

The TDF8704T is an 8-bit high-speed analog-to-digital converter (ADC) for general industrial applications. It converts the analog input signal into 8-bit binary-coded digital words at a maximum sampling rate of 50 MHz. All digital inputs and outputs are TTL compatible, although a low-level AC clock input signal is allowed.

## QUICK REFERENCE DATA

SYMBOL	PARAMETER	CONDITIONS	MIN.	TYP.	MAX.	UNIT
$V_{\text{CCA}}$	analog supply voltage		4.75	5.0	5.25	V
$V_{\text{CCD}}$	digital supply voltage		4.75	5.0	5.25	V
$V_{\text{CCO}}$	output stages supply voltage		4.75	5.0	5.25	V
$I_{\text{CCA}}$	analog supply current		-	37	46	mA
$I_{\text{CCD}}$	digital supply current		-	23	35	mA
$I_{\text{CCO}}$	output stages supply current		-	16	21	mA
ILE	DC integral linear error		-	$\pm 0.4$	$\pm 1$	LSB
DLE	DC differential linearity error		-	$\pm 0.2$	$\pm 0.5$	LSB
AILE	AC integral linearity error	note 1	-	-	$\pm 2$	LSB
$f_{\text{clk(max)}}$	maximum clock frequency		50	-	-	MHz
$P_{\text{tot}}$	total power dissipation		-	380	535	mW

## Note

1. Full-scale sine wave ( $f_i = 4.43$  MHz;  $f_{\text{clk}} = 50$  MHz).

## ORDERING INFORMATION

TYPE NUMBER	PACKAGE				SAMPLING FREQUENCY
	PINS	PIN POSITION	MATERIAL	CODE	
TDF8704T/2	24	SO24L	plastic	SOT137-1	20 MHz
TDF8704T/4	24	SO24L	plastic	SOT137-1	40 MHz
TDF8704T/5	24	SO24L	plastic	SOT137-1	50 MHz

# 8-bit high-speed analog-to-digital converter

# TDF8704

## BLOCK DIAGRAM

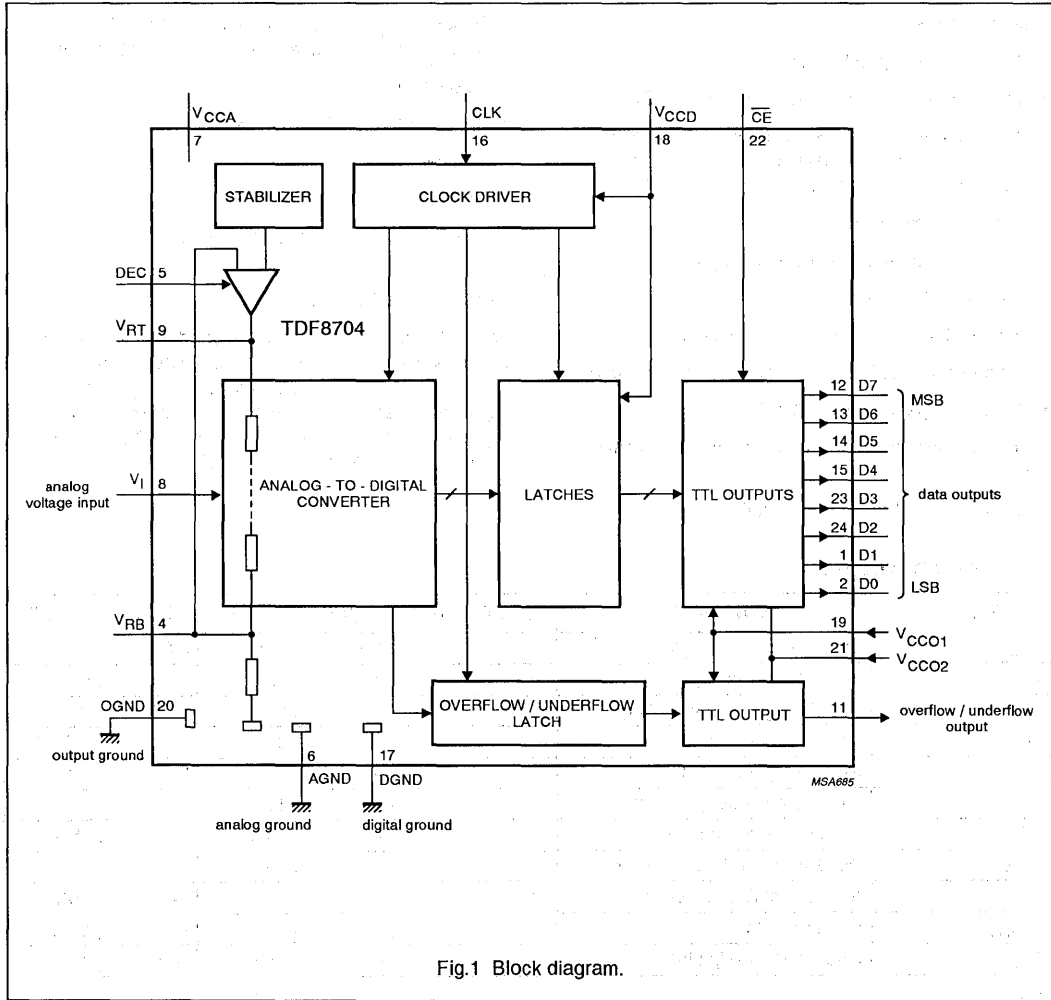

Fig.1 Block diagram.

## 8-bit high-speed analog-to-digital converter

TDF8704

## PINNING

SYMBOL	PIN	DESCRIPTION
D1	1	data output; bit 1
D0	2	data output; bit 0 (LSB)
n.c.	3	not connected
V <sub>RB</sub>	4	reference voltage BOTTOM (decoupling)
DEC	5	decoupling input (internal stabilization loop decoupling)
AGND	6	analog ground
V <sub>CCA</sub>	7	analog supply voltage (+5 V)
V <sub>I</sub>	8	analog input voltage
V <sub>RT</sub>	9	reference voltage TOP (decoupling)
n.c.	10	not connected
O/UF	11	overflow/underflow data output
D7	12	data output; bit 7 (MSB)
D6	13	data output; bit 6
D5	14	data output; bit 5
D4	15	data output; bit 4
CLK	16	clock input
DGND	17	digital ground
V <sub>CCD</sub>	18	digital supply voltage (+5 V)
V <sub>CCO1</sub>	19	supply voltage for output stages 1 (+5 V)
OGND	20	output ground
V <sub>CCO2</sub>	21	supply voltage for output stages 2 (+5 V)
$\overline{\text{CE}}$	22	chip enable input (TTL level input, active LOW)
D3	23	data output; bit 3
D2	24	data output; bit 2

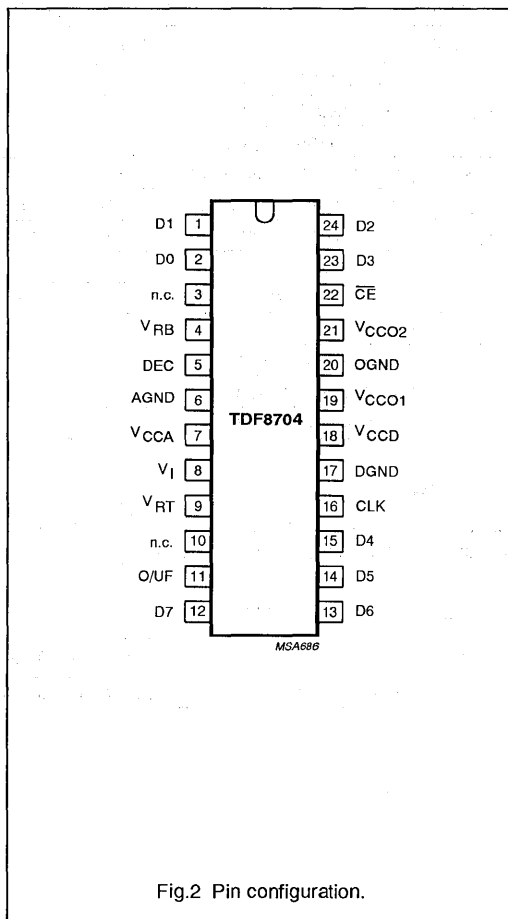

Fig.2 Pin configuration.

## 8-bit high-speed analog-to-digital converter

TDF8704

**LIMITING VALUES**

In accordance with the Absolute Maximum Rating System (IEC134).

SYMBOL	PARAMETER	CONDITIONS	MIN.	MAX.	UNIT
$V_{CCA}$	analog supply voltage		-0.3	+7.0	V
$V_{CCD}$	digital supply voltage		-0.3	+7.0	V
$V_{CCO}$	output stages supply voltage		-0.3	+7.0	V
$\Delta V_{CC}$	supply voltage differences between $V_{CCA}$ and $V_{CCD}$		-1.0	+1.0	V
$\Delta V_{CC}$	supply voltage differences between $V_{CCO}$ and $V_{CCD}$		-1.0	+1.0	V
$\Delta V_{CC}$	supply voltage differences between $V_{CCA}$ and $V_{CCO}$		-1.0	+1.0	V
$V_I$	input voltage	referenced to AGND	-0.3	+7.0	V
$V_{clk(p-p)}$	AC input voltage for switching (peak-to-peak value)	referenced to DGND	-	$V_{CCD}$	V
$I_O$	output current		-	10	mA
$T_{stg}$	storage temperature		-55	+150	°C
$T_{amb}$	operating ambient temperature		-40	+85	°C
$T_j$	junction temperature		-	+150	°C

**HANDLING**

Inputs and outputs are protected against electrostatic discharges in normal handling. However, to be totally safe, it is desirable to take normal precautions appropriate to handling integrated circuits.

**THERMAL CHARACTERISTICS**

SYMBOL	PARAMETER	VALUE	UNIT
$R_{th\ j-a}$	thermal resistance from junction to ambient in free air	75	K/W



## 8-bit high-speed analog-to-digital converter

TDF8704

**CHARACTERISTICS (see Tables 1 and 2)**

$V_{CCA} = V_7$  to  $V_6 = 4.75$  to  $5.25$  V;  $V_{CCD} = V_{18}$  to  $V_{17} = 4.75$  to  $5.25$  V;  $V_{CCO} = V_{19}$  and  $V_{21}$  to  $V_{20} = 4.75$  to  $5.25$  V; AGND and DGND shorted together;  $V_{CCA}$  to  $V_{CCD} = -0.25$  to  $+0.25$  V;  $V_{CCO}$  to  $V_{CCD} = -0.25$  to  $+0.25$  V;

$V_{CCA}$  to  $V_{CCD} = -0.25$  to  $+0.25$  V;  $T_{amb} = -40$  to  $+85$  °C; typical readings taken at  $V_{CCA} = V_{CCD} = 5$  V and  $T_{amb} = 25$  °C; unless otherwise specified.

SYMBOL	PARAMETER	CONDITIONS	MIN.	TYP.	MAX.	UNIT
<b>Supply</b>						
$V_{CCA}$	analog supply voltage		4.75	5.0	5.25	V
$V_{CCD}$	digital supply voltage		4.75	5.0	5.25	V
$V_{CCO}$	output stages supply voltage		4.75	5.0	5.25	V
$I_{CCA}$	analog supply current		–	37	46	mA
$I_{CCD}$	digital supply current		–	23	35	mA
$I_{CCO}$	output stages supply current	all outputs LOW	–	16	21	mA
<b>Inputs</b>						
CLOCK INPUT CLK (REFERENCED TO DGND)						
$V_{IL}$	LOW level input voltage		0	–	0.8	V
$V_{IH}$	HIGH level input voltage		2.0	–	$V_{CCD}$	V
$I_{IL}$	LOW level input current	$V_{clk} = 0.4$ V	–400	–	–	µA
$I_{IH}$	HIGH level input current	$V_{clk} = 2.7$ V	–	–	100	µA
		$V_{clk} = V_{CCD}$	–	–	300	µA
$Z_I$	input impedance	$f_{clk} = 50$ MHz	–	2	–	kΩ
$C_I$	input capacitance	$f_{clk} = 50$ MHz	–	4.5	–	pF
$V_I$ (ANALOG INPUT VOLTAGE REFERENCED TO AGDN; SEE FIGS 3 AND 4 AND TABLE 1)						
$V_{I(B)}$	input voltage (BOTTOM)		1.21	1.25	1.29	V
$V_{I(O)}$	input voltage	output code = 0	1.42	1.48	1.51	V
$V_{os(B)}$	offset voltage (BOTTOM)	$V_{I(O)}$ to $V_{I(B)}$	210	225	240	V
$V_{I(T)}$	input voltage (TOP)		3.37	3.46	3.58	V
$V_{I(255)}$	input voltage	output code = 255	3.14	3.22	3.30	V
$V_{os(T)}$	offset voltage (TOP)	$V_{I(T)}$ to $V_{I(255)}$	225	240	255	V
$V_{I(p-p)}$	input voltage amplitude (peak-to-peak value)		1.69	1.74	1.79	V
$I_L$	load current on $V_{RT}$ and $V_{RB}$		–300	–	+300	µA
$I_{IL}$	LOW level input current	$V_I = 1.25$ V	–	0	–	µA
$I_{IH}$	HIGH level input current	$V_I = 3.46$ V	40	150	400	µA
$Z_I$	input impedance	$f_i = 4.43$ MHz	–	10	–	kΩ
$C_I$	input capacitance	$f_i = 4.43$ MHz	–	14	–	pF

## 8-bit high-speed analog-to-digital converter

TDF8704

SYMBOL	PARAMETER	CONDITIONS	MIN.	TYP.	MAX.	UNIT
INPUT $\overline{CE}$ (REFERENCED TO DGND) SEE TABLE 2						
$V_{IL}$	LOW level input voltage		0	–	0.8	V
$V_{IH}$	HIGH level input voltage		2.0	–	$V_{CCD}$	V
$I_{IL}$	LOW level input current	$V_{IL} = 0.4$ V	–400	–	–	$\mu$ A
$I_{IH}$	HIGH level input current	$V_{IH} = 2.7$ V	–	–	20	$\mu$ A
<b>Reference resistance</b>						
$R_{ref}$	reference resistance	$V_{RT}$ to $V_{RB}$	–	200	–	$\Omega$
<b>Outputs</b>						
DIGITAL OUTPUTS D7 TO D0 (REFERENCED TO DGND)						
$V_{OL}$	LOW level output voltage	$I_O = 1$ mA; $T_{amb} = 0$ to $+85$ °C	0	–	0.4	V
		$I_O = 1$ mA; $T_{amb} = 0$ to $-40$ °C	–	–	0.6	V
$V_{OH}$	HIGH level output voltage	$I_O = -0.4$ mA	2.7	–	$V_{CCD}$	V
$I_{OZ}$	output current in 3-state mode	$0.4$ V < $V_O$ < $V_{CCD}$	–20	–	+20	$\mu$ A
<b>Switching characteristics</b>						
CLOCK INPUT CLK (NOTE 1; SEE FIG. 5)						
$f_{clk(max)}$	maximum clock frequency	TDF8704T/2	20	–	–	MHz
		TDF8704T/4	40	–	–	MHz
		TDF8704T/5	50	–	–	MHz
$t_{CPH}$	clock pulse width HIGH		7	–	–	ns
$t_{CPL}$	clock pulse width LOW		7	–	–	ns
<b>Analog signal processing</b>						
LINEARITY						
$\Delta ILE$	DC integral linearity error		–	$\pm 0.4$	$\pm 1.0$	LSB
$\Delta DLE$	DC differential linearity error		–	$\pm 0.2$	$\pm 0.5$	LSB
$\Delta AILE$	AC integral linearity error	note 2	–	–	$\pm 2.0$	LSB
BANDWIDTH ( $f_{clk} = 40$ MHz)						
B	–0.5 dB analog bandwidth (note 3)	full-scale sine wave	–	12	–	MHz
		75% full-scale sine wave	–	16	–	MHz
$t_{STLH}$	analog input settling time LOW-to-HIGH	full-scale square wave; Fig. 8; note 4	–	2.5	3.5	ns
$t_{STHL}$	analog input settling time HIGH-to-LOW	full-scale square wave; Fig. 8; note 4	–	3.0	4.0	ns

## 8-bit high-speed analog-to-digital converter

TDF8704

SYMBOL	PARAMETER	CONDITIONS	MIN.	TYP.	MAX.	UNIT	
HARMONICS ( $f_{\text{clk}} = 40 \text{ MHz}$ )							
$h_1$	fundamental harmonics (full scale)	$f_i = 4.43 \text{ MHz}$	-	-	0	dB	
$h_{\text{all}}$	harmonics (full scale); all components	$f_i = 4.43 \text{ MHz}$					
	second harmonics		-	-64	-60	dB	
	third harmonics		-	-58	-55	dB	
THD	total harmonic distortion	$f_i = 4.43 \text{ MHz}$	-	-56	-	dB	
SIGNAL-TO-NOISE RATIO							
S/N	signal-to-noise ratio	without harmonics; $f_{\text{clk}} = 40 \text{ MHz};$ $f_i = 4.43 \text{ MHz}$	46	48	-	dB	
EFFECTIVE BITS; NOTE 5; SEE FIGS 9, 10 AND 11							
EB	effective bits TDF8704T/2	$f_{\text{clk}} = 20 \text{ MHz}$					
		$f_i = 1.25 \text{ MHz}$	-	7.8	-	bits	
		$f_i = 4.43 \text{ MHz}$	-	7.6	-	bits	
	effective bits TDF8704T/4	$f_{\text{clk}} = 40 \text{ MHz}$					
		$f_i = 4.43 \text{ MHz}$	-	7.5	-	bits	
		$f_i = 7.5 \text{ MHz}$	-	7.3	-	bits	
		$f_i = 10 \text{ MHz}$	-	7.0	-	bits	
	effective bits TDF8704T/5	$f_{\text{clk}} = 50 \text{ MHz}$					
		$f_i = 4.43 \text{ MHz}$	-	7.4	-	bits	
$f_i = 7.5 \text{ MHz}$		-	7.2	-	bits		
	$f_i = 10 \text{ MHz}$	-	6.9	-	bits		
TWO-TONE (NOTE 6)							
TTIR	two-tone intermodulation rejection	$f_{\text{clk}} = 40 \text{ MHz}$	-	-56	-	dB	
BIT ERROR RATE							
BER	bit error rate	$f_{\text{clk}} = 40 \text{ MHz};$ $f_i = 4.43 \text{ MHz};$ $V_I = \pm 16 \text{ LSB at code 128}$	-	$10^{-11}$	-	times/ samples	
DIFFERENTIAL GAIN (NOTE 7)							
$G_{\text{diff}}$	differential gain	$f_{\text{clk}} = 20 \text{ MHz};$ $f_i = 4.43 \text{ MHz}$	-	0.6	-	%	
DIFFERENTIAL PHASE (NOTE 7)							
$\varphi_{\text{diff}}$	differential phase	$f_{\text{clk}} = 40 \text{ MHz};$ $f_i = 4.43 \text{ MHz}$	-	0.8	-	deg	

8-bit high-speed analog-to-digital converter

TDF8704

SYMBOL	PARAMETER	CONDITIONS	MIN.	TYP.	MAX.	UNIT
<b>Timing (note 8; see Figs 5 and 7; <math>f_{clk} = 50</math> MHz)</b>						
$t_{ds}$	sampling delay time		-	-	2	ns
$t_h$	output hold time		5	-	-	ns
$t_d$	output delay time		-	12	15	ns
<b>3-state output delay times (see Figs 6 and 7)</b>						
$t_{dZH}$	enable HIGH		-	6	10	ns
$t_{dZL}$	enable LOW		-	12	16	ns
$t_{dHZ}$	disable HIGH		-	50	54	ns
$t_{dLZ}$	disable LOW		-	10	14	ns

Notes

- In addition to a good layout of the digital and analog ground, it is recommended that the rise and fall times of the clock must be less than 1 ns.
- Full-scale sine wave ( $f_i = 4.43$  MHz;  $f_{clk} = 50$  MHz).
- Determined by beat frequency method on a reconstructed sine wave signal for no missing codes and no glitches.
- The analog input settling time is the minimum time required for the input signal to be stabilized after a sharp full-scale input (square-wave signal) in order to sample the signal and obtain correct output data.
- Effective bits are obtained via a Fast Fourier Transform (FFT) treatment taking 4K acquisition points per period. The calculation takes into account all harmonics and noise up to half of the clock frequency (NYQUIST frequency). Conversion to signal-to-noise ratio:  $S/N = EB \times 6.02 + 1.76$  dB.
- Intermodulation measured relative to either tone with analog input frequencies of 4.43 MHz and 4.53 MHz. The two input signals have the same amplitude and the total amplitude of both signals provides full scale to the converter.
- Measurement taken using video analyser VM700A.
- Output data acquisition: the output data is available after the maximum delay time of  $t_d$ .

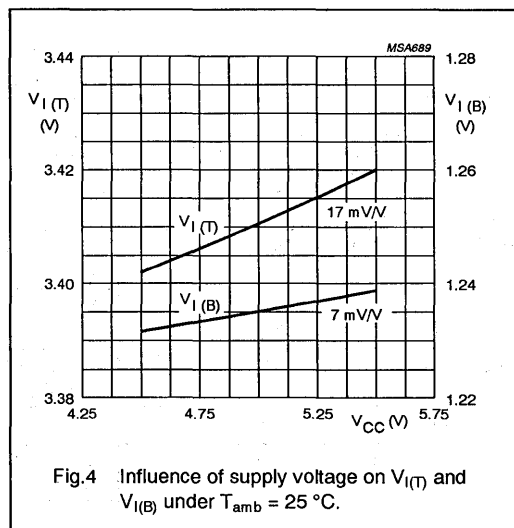
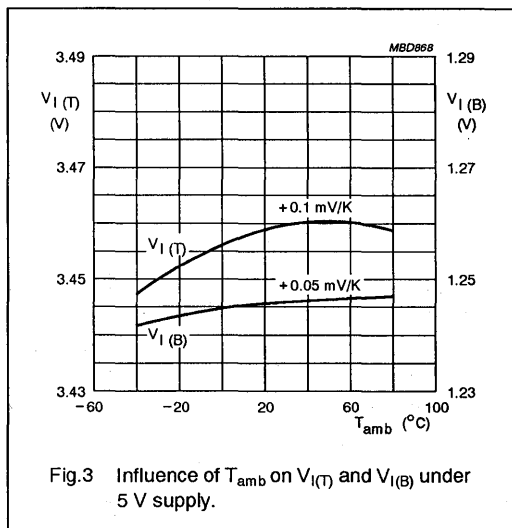

8-bit high-speed analog-to-digital converter

TDF8704

**Table 1** Output coding and input voltage (typical values; referenced to AGND).

STEP	$V_{I(p-p)}$	O/UF	BINARY OUTPUT BITS							
			D7	D6	D5	D4	D3	D2	D1	D0
Underflow	<1.48	1	1	0	0	0	0	0	0	0
0	1.48	0	0	0	0	0	0	0	0	0
1	-	0	0	0	0	0	0	0	0	1
.	.	.	.	.	.	.	.	.	.	.
.	.	.	.	.	.	.	.	.	.	.
254	.	0	1	1	1	1	1	1	1	0
255	3.46	0	1	1	1	1	1	1	1	1
Overflow	>3.46	1	1	1	1	1	1	1	1	1

**Table 2** Mode selection.

CE	D7 TO D0	O/UF
1	high impedance	high impedance
0	active; binary	active

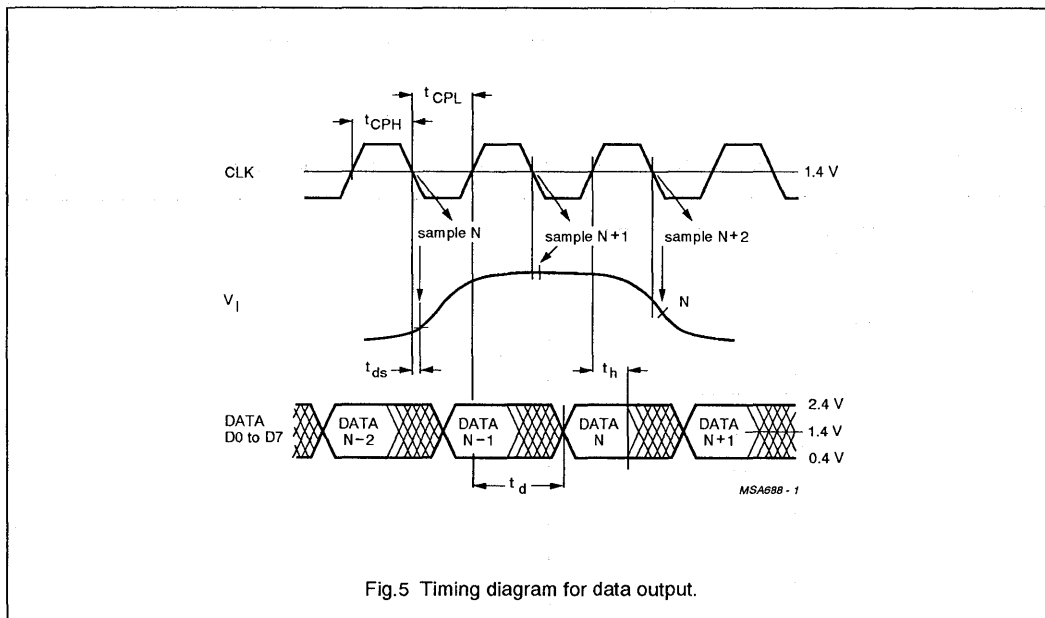
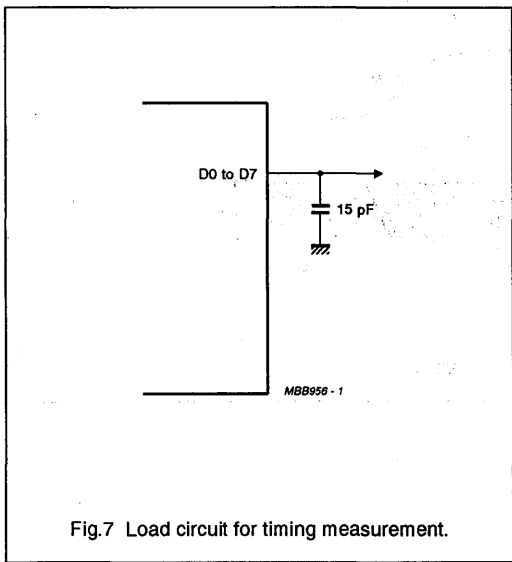
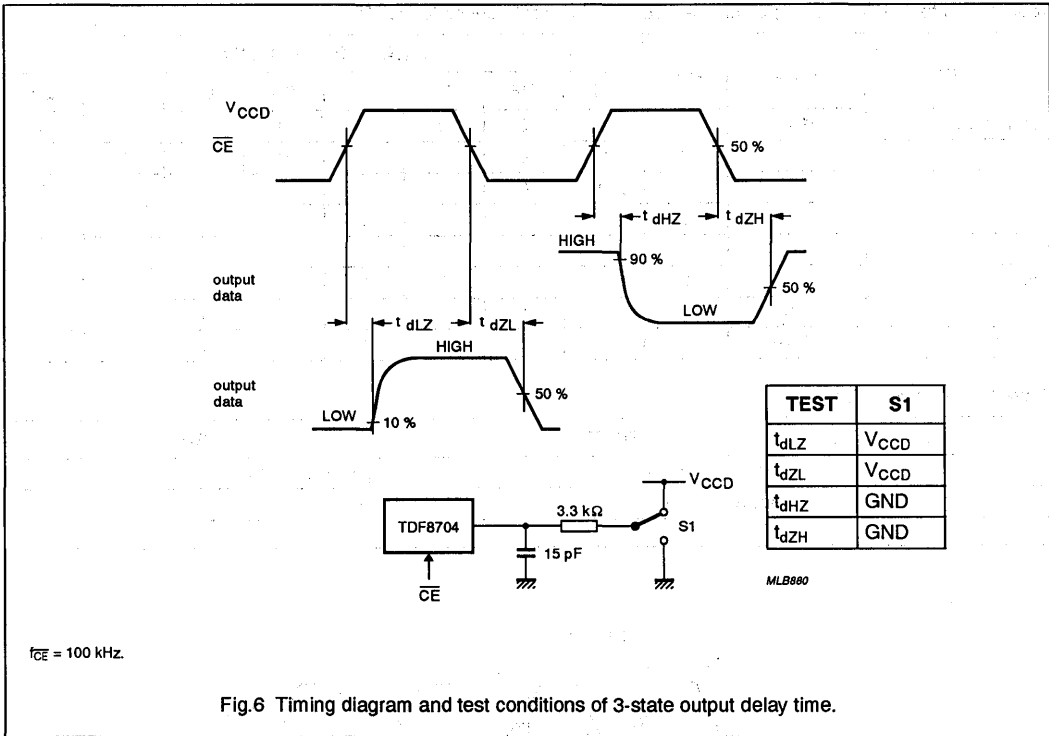

Fig.5 Timing diagram for data output.

8-bit high-speed analog-to-digital converter

TDF8704



8-bit high-speed analog-to-digital converter

TDF8704

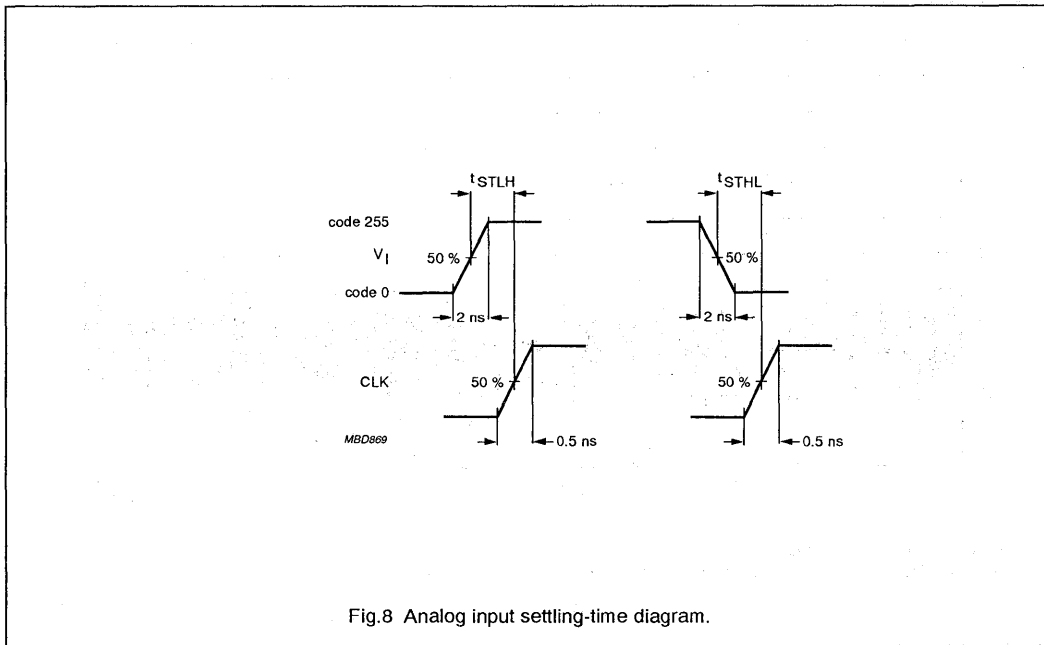

Fig.8 Analog input settling-time diagram.

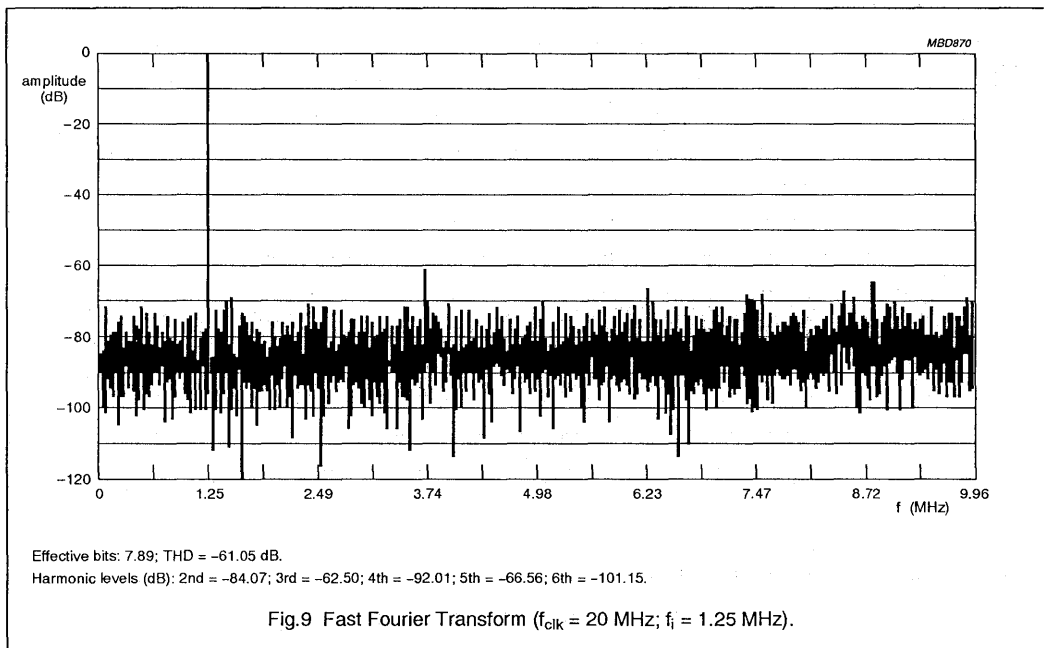
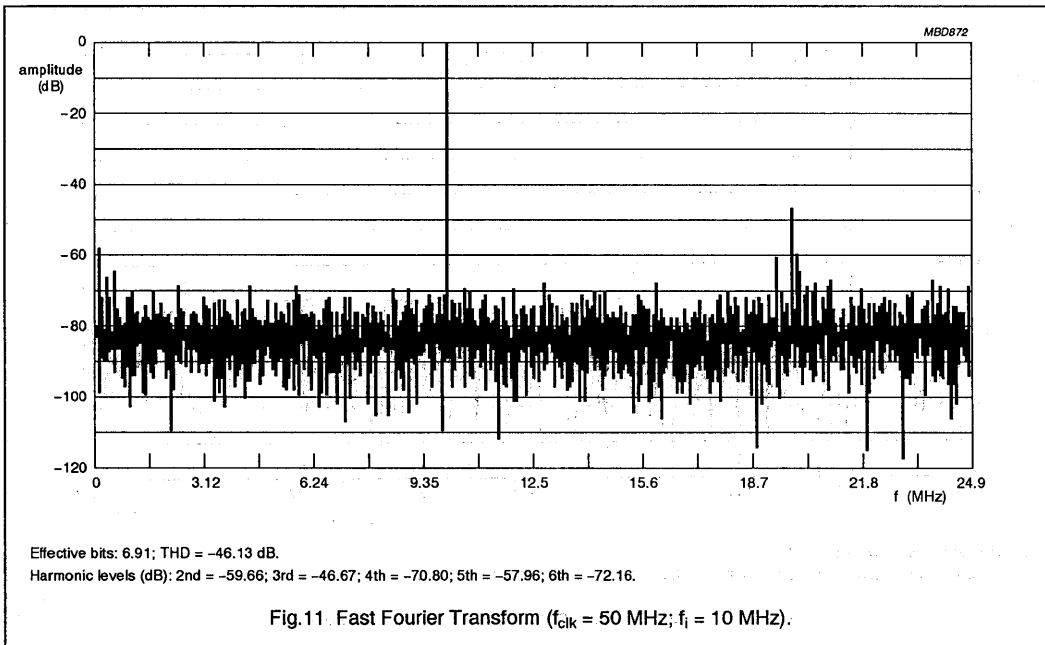
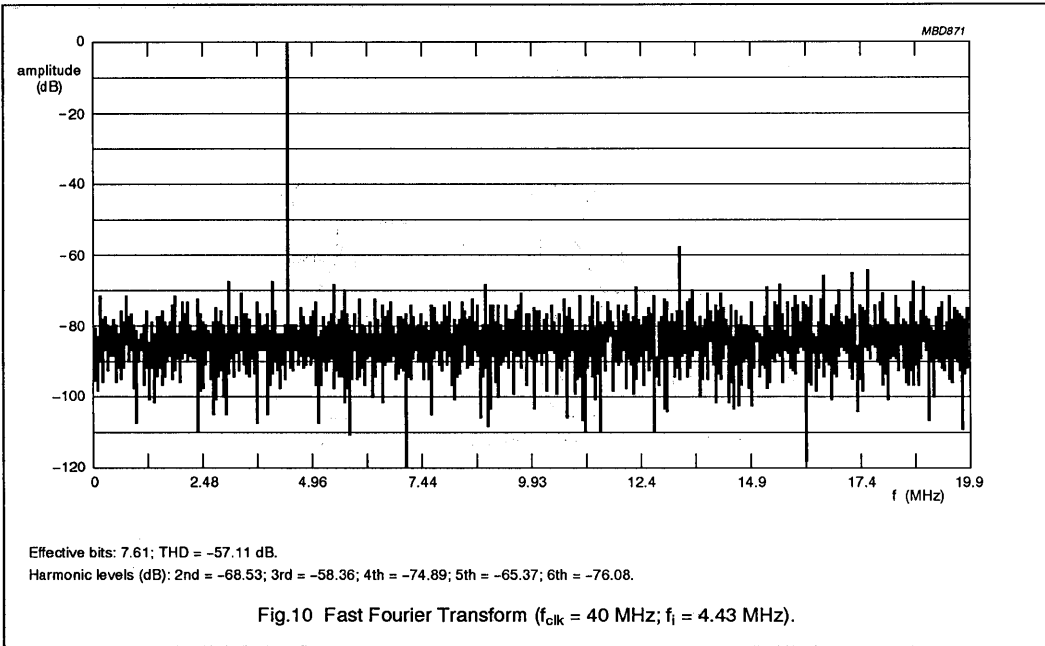

Fig.9 Fast Fourier Transform ( $f_{clk} = 20$  MHz;  $f_i = 1.25$  MHz).

8-bit high-speed analog-to-digital converter TDF8704





8-bit high-speed analog-to-digital converter

TDF8704

INTERNAL PIN CONFIGURATIONS

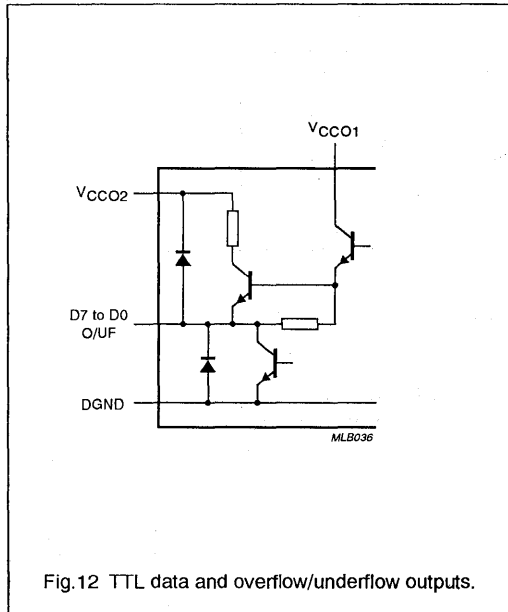

Fig.12 TTL data and overflow/underflow outputs.

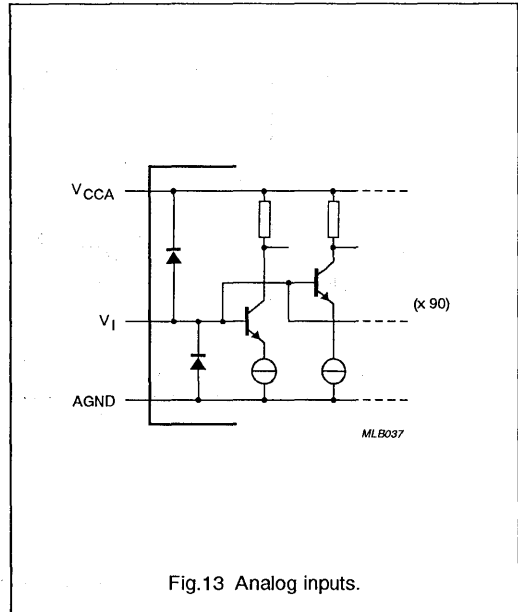

Fig.13 Analog inputs.

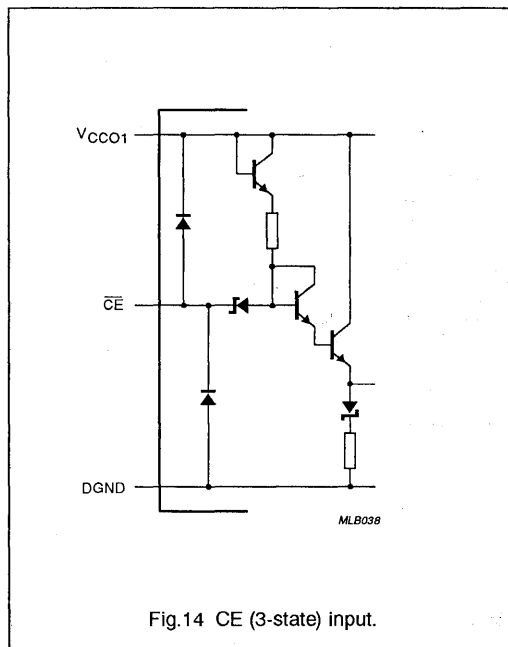
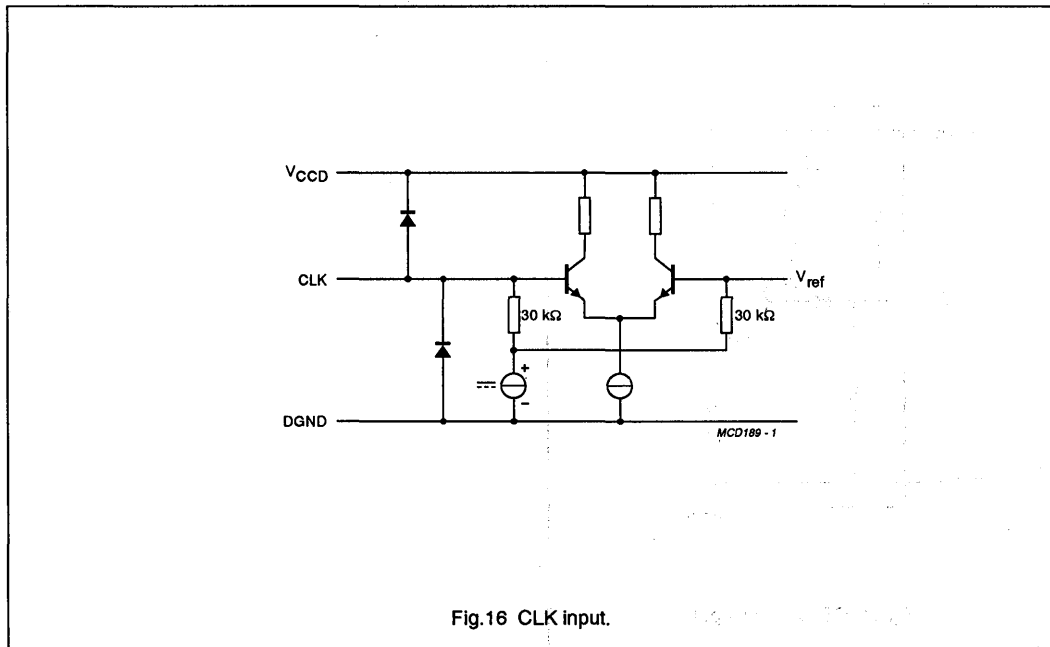
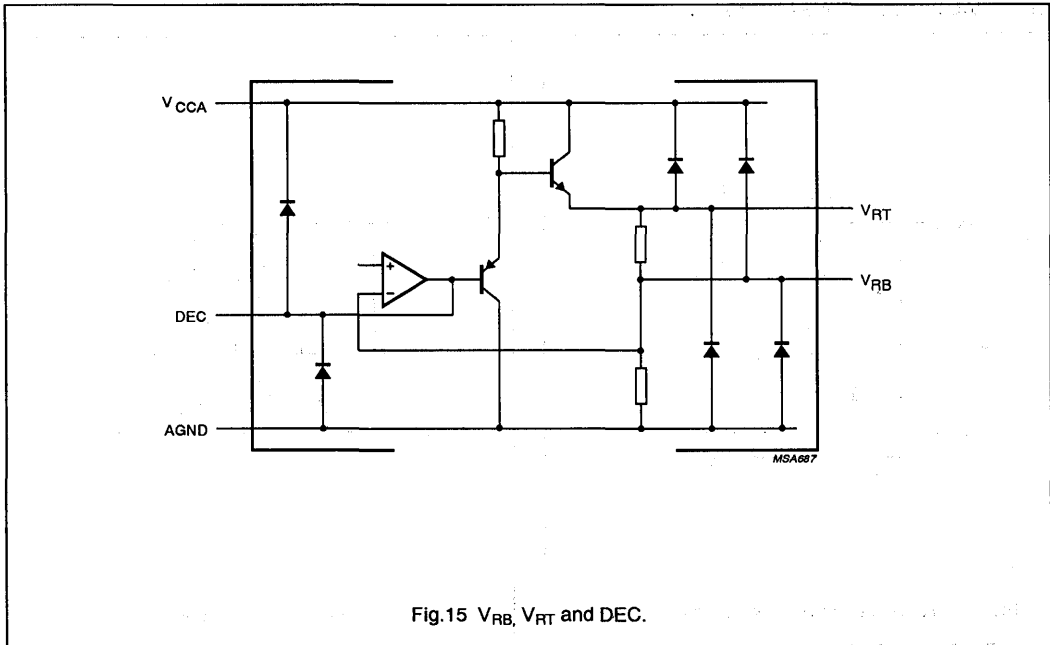

Fig.14 CE (3-state) input.

# 8-bit high-speed analog-to-digital converter TDF8704



## 8-bit high-speed analog-to-digital converter

TDF8704

## APPLICATION INFORMATION

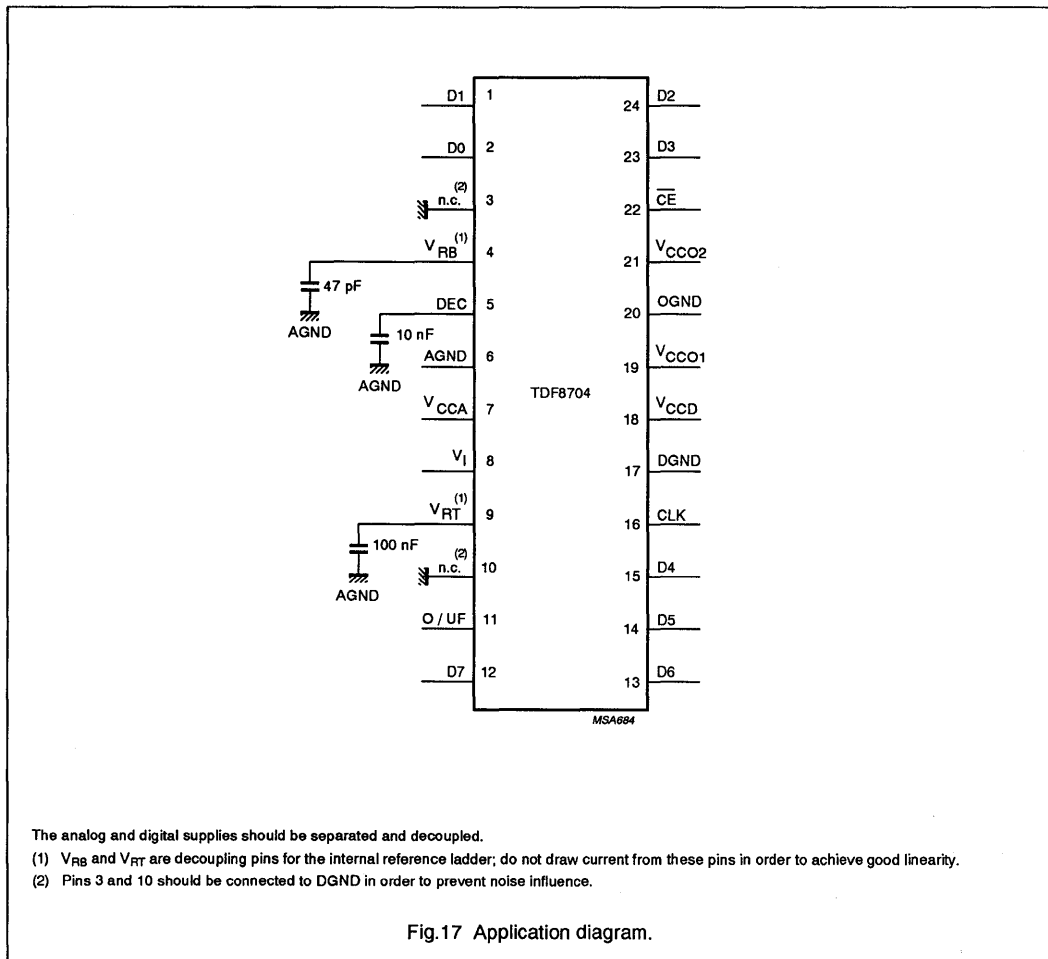

Fig.17 Application diagram.



# Section 4

## Package Outlines

### CONTENTS

SOT38-1	Plastic dual in-line package; 16 leads (300 mil) .....	4-3
SOT96A	8-Pin Plastic SOL (Small Outline Large) Dual In-Line (D/T) Package .....	4-4
SOT101	24-Pin Plastic Dual In-Line (N/P) Package with Internal Heatspreader .....	4-5
SOT102	18-Pin Plastic Dual In-Line (N/P) Package with Internal Heatspreader .....	4-6
SOT109A	16-Pin Plastic SO (Small Outline) Dual In-Line (D/T) Package .....	4-7
SOT117-1	Plastic dual in-line package; 28 leads (600 mil) with internal heat spreader .....	4-8
SOT129	40-Pin Plastic Dual In-Line (N/P) Package .....	4-9
SOT136-1	Plastic small outline package; 28 leads; large body .....	4-10
SOT137-1	Plastic small outline package; 24 leads; large body .....	4-11
SOT146EF4	20-Lead Dual In-Line; Plastic .....	4-12
SOT158A	40-Pin Plastic VSO (Very Small Outline) Dual In-Line (D/T) Package .....	4-13
SOT162-1	Plastic small outline package; 16 leads; large body .....	4-14
SOT163AG7	20-Lead Mini-pack; Plastic .....	4-15
SOT187	44-Pin Plastic Leaded Chip Carrier; Pocket Version (A) Package .....	4-16
SOT188AA	68-Pin Plastic Leaded Chip Carrier; Pocket Version (A) Package .....	4-17
SOT189CG	84-Pin Plastic Leaded Chip Carrier (A) Package .....	4-18
SOT225	160-Pin Plastic Quad Flat Pack (H) Package .....	4-19
SOT232	32-Pin Plastic Shrink Dual In-Line (N/P) Package .....	4-21
SOT234AG	24-Lead Plastic Shrink Dual In-Line Package .....	4-22
SOT247-1	52-Pin Shrink Dual In-Line Package; Plastic .....	4-23
SOT261-2	Plastic leaded chip carrier, 28 leads .....	4-24
SOT287-1	Plastic small outline package; 32 leads; large body .....	4-25
SOT307-2	44-Pin Plastic Quad Flat Pack (B) Package .....	4-26
SOT313-2	Plastic thin quad flat package; 48 leads; 7 x 7 x 1.4 mm .....	4-27
SOT317	100-Pin Plastic Quad Flat Pack (B) Package .....	4-28
SOT318	80-Pin Plastic Quad Flat Pack (B) Package .....	4-29
SOT340-1	Plastic shrink small outline package; 24 leads; medium body .....	4-30
SOT349	120-Pin Plastic Quad Flat Pack (B) Package .....	4-31



# Package outlines

## SOT38-1 PLASTIC DUAL IN-LINE PACKAGE; 16 LEADS (300 MIL)

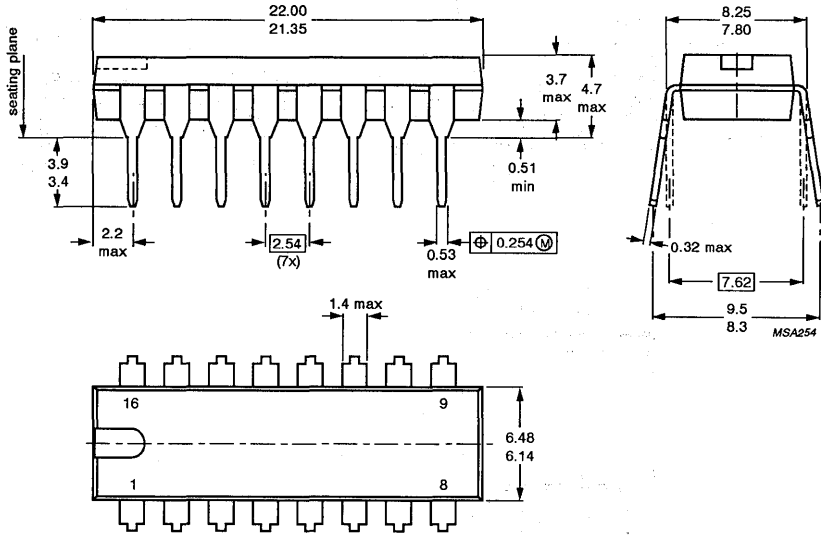

Dimensions in mm.

# Package outlines

## SOT96A 8-PIN PLASTIC SOL (SMALL OUTLINE LARGE) DUAL IN-LINE (D/T) PACKAGE

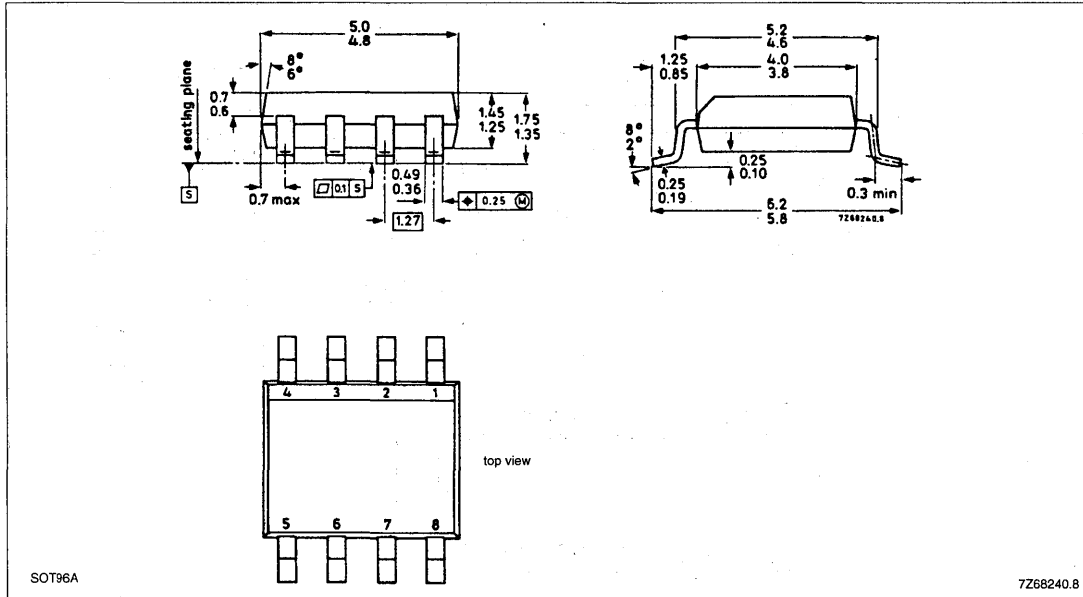



# Package outlines

## SOT101 24-PIN PLASTIC DUAL IN-LINE (N/P) PACKAGE WITH INTERNAL HEATSPREADER

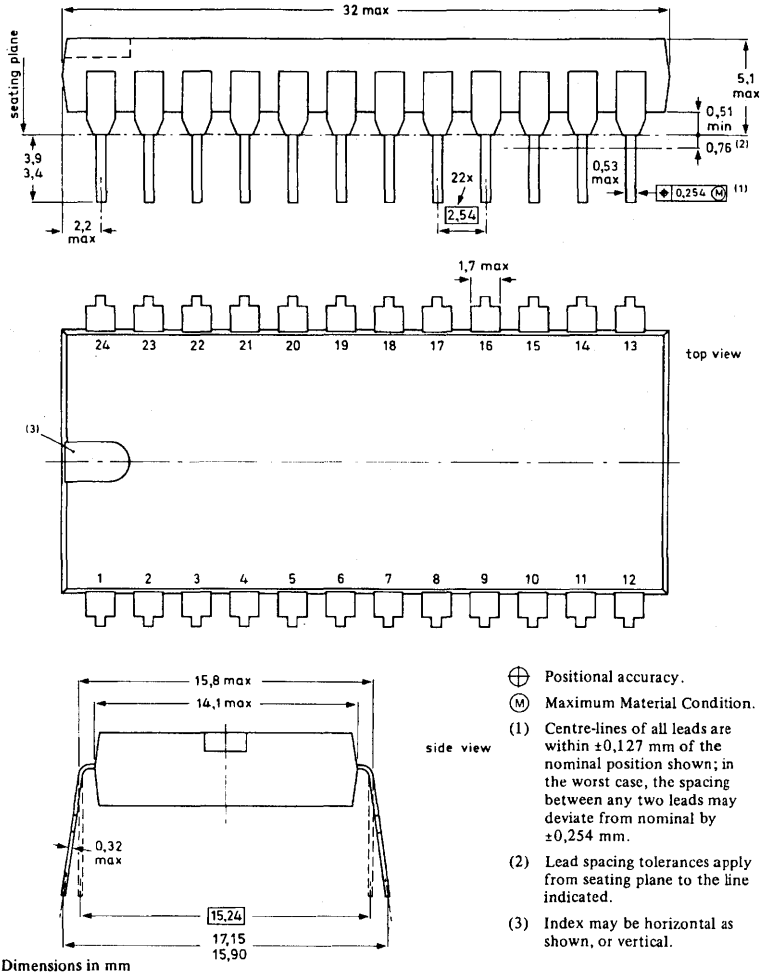

SOT101A, B, F, G, L

7273670.5

# Package outlines

## SOT102 18-PIN PLASTIC DUAL IN-LINE (N/P) PACKAGE WITH INTERNAL HEATSPREADER

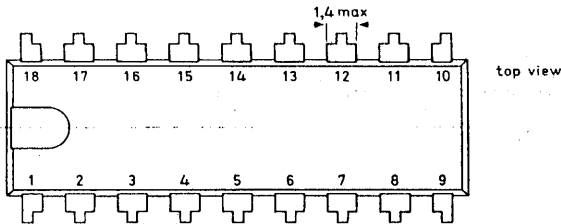
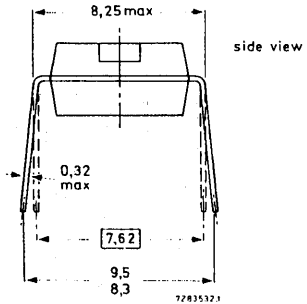
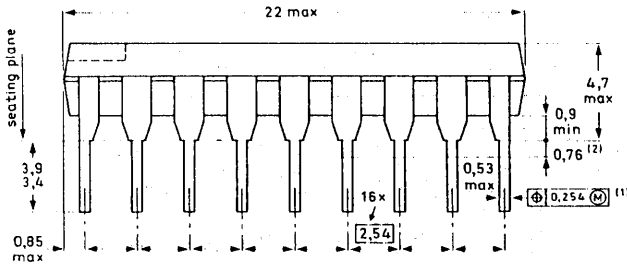

- (1) Centre-lines of all leads are within +0.127 mm of the nominal position shown; in the worst case, the spacing between any two leads may deviate from nominal by  $\pm 0.254$  mm.
- (2) Lead spacing tolerances apply from seating plane to the line indicated.
- (3) Dimensions in mm.

SOT 102

7283532.1

# Package outlines

## SOT109A 16-PIN PLASTIC SO (SMALL OUTLINE) DUAL IN-LINE (D/T) PACKAGE

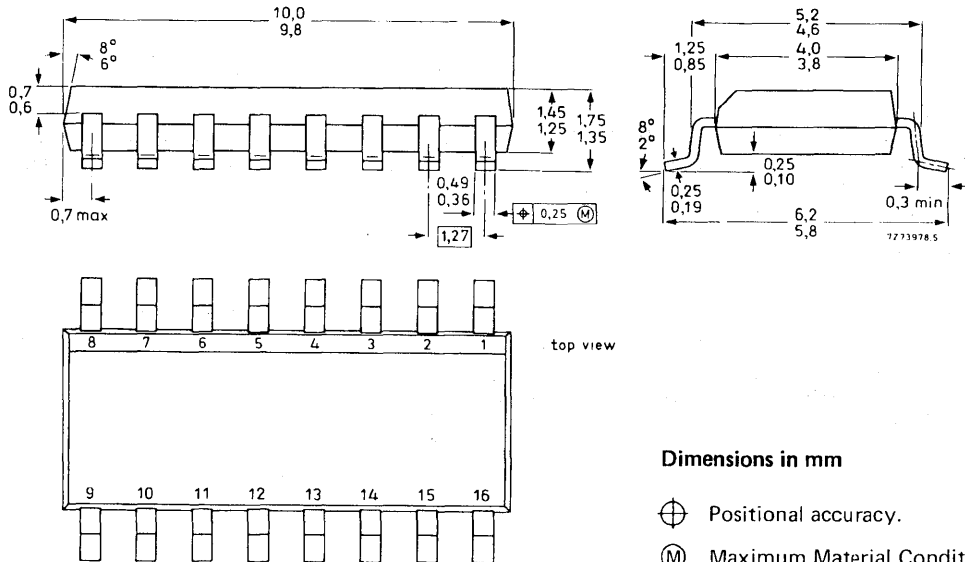

Dimensions in mm

- ⊕ Positional accuracy.
- Ⓜ Maximum Material Condition.

SOT 109A

7273978.5

# Package outlines

## SOT117-1 PLASTIC DUAL IN-LINE PACKAGE; 28 LEADS (600 MIL) WITH INTERNAL HEAT SPREADER

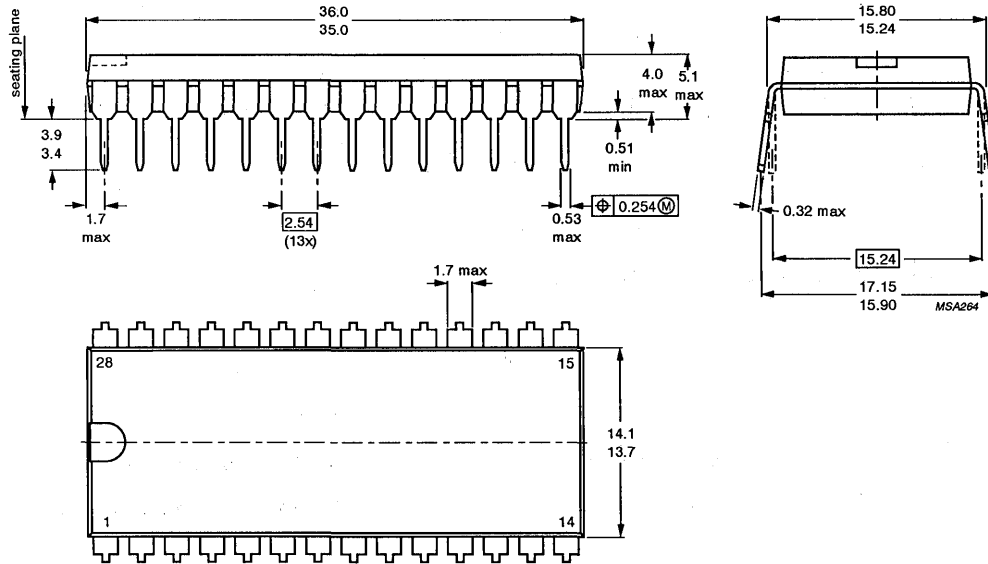

Dimensions in mm.

SOT117-1

# Package outlines

## SOT129 40-PIN PLASTIC DUAL IN-LINE (N/P) PACKAGE

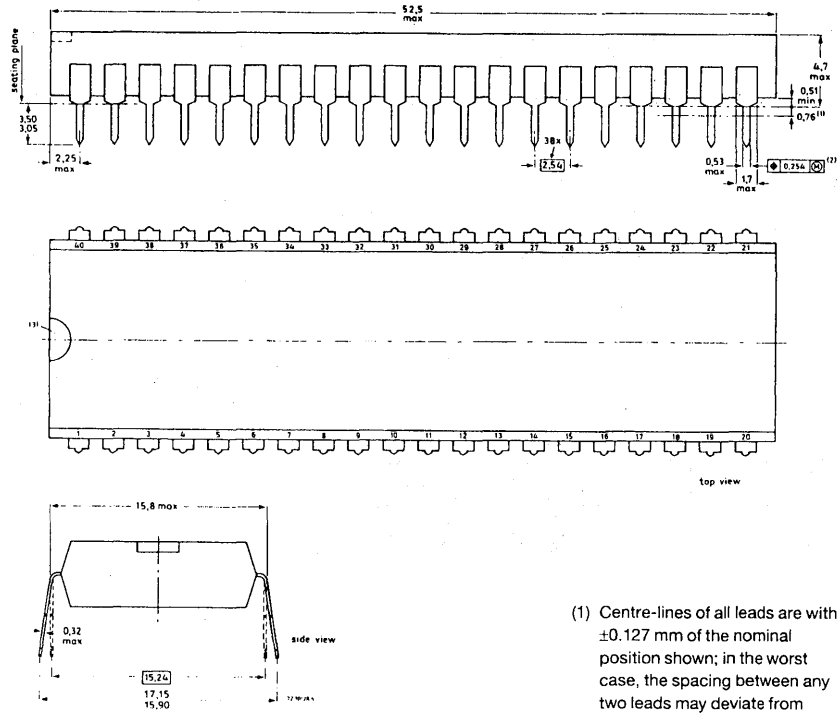

- (1) Centre-lines of all leads are within  $\pm 0.127$  mm of the nominal position shown; in the worst case, the spacing between any two leads may deviate from nominal by  $\pm 0.254$  mm.
- (2) Lead spacing tolerances apply from seating plane to the line indicated.
- (3) Index may be horizontal as shown, or vertical
- (4) Dimensions in mm.

SOT 129

7Z70128.5

# Package outlines

## SOT136-1 PLASTIC SMALL OUTLINE PACKAGE; 28 LEADS; LARGE BODY

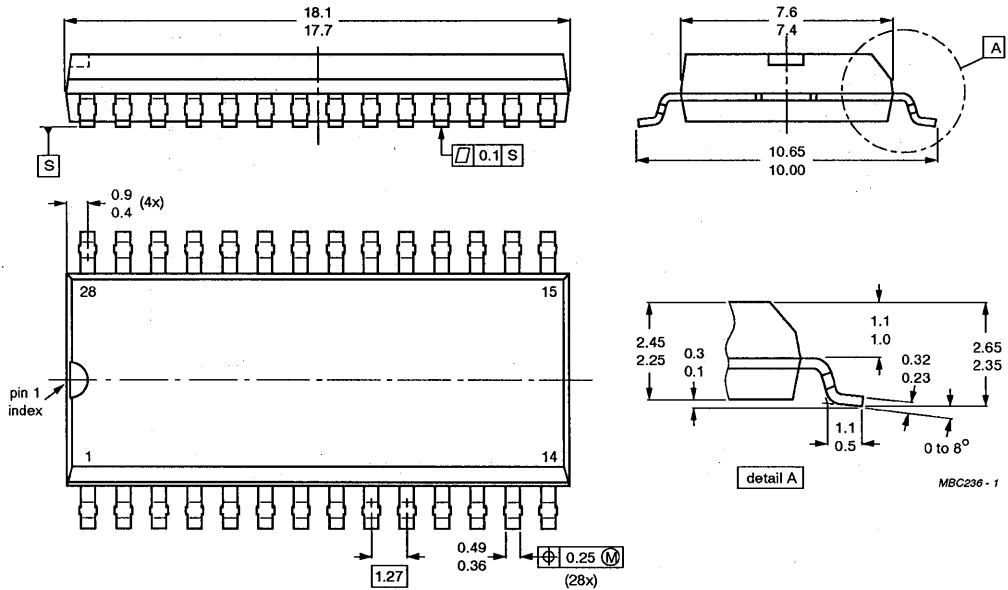

SOT136-1

MBC236 - 1

# Package outlines

## SOT137-1 PLASTIC SMALL OUTLINE PACKAGE; 24 LEADS; LARGE BODY

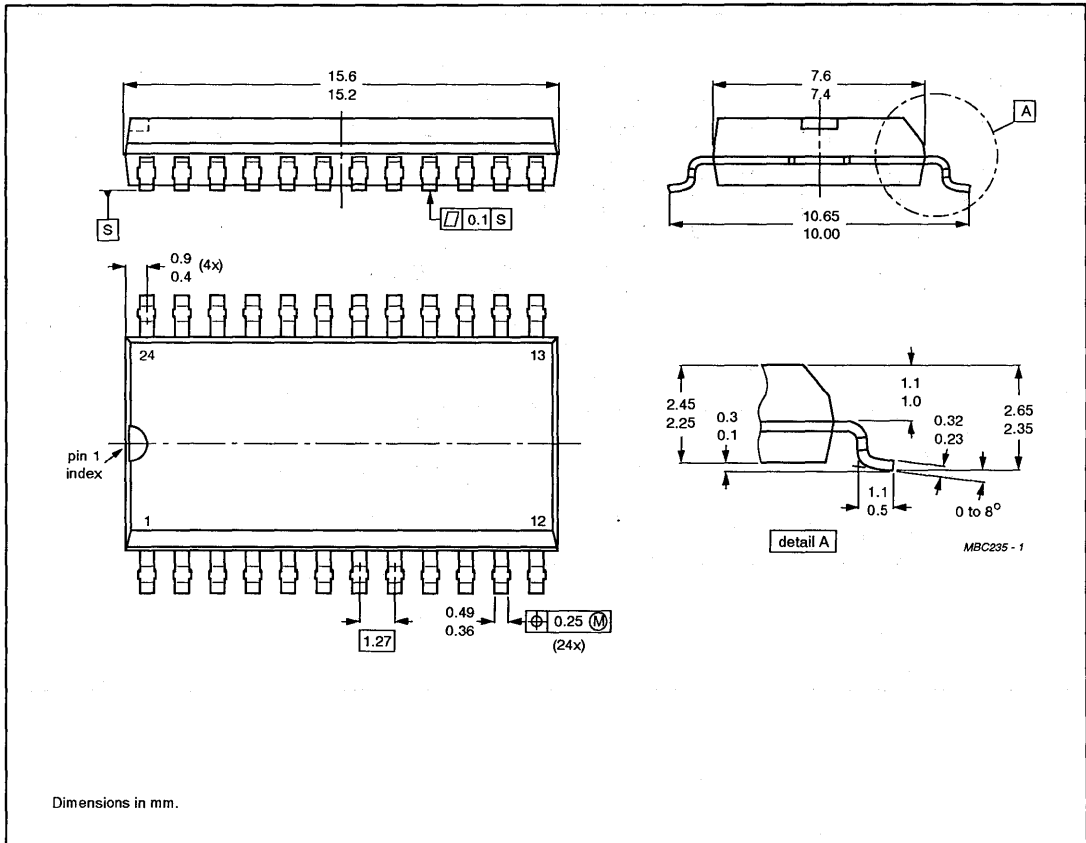

# Package outlines

## SOT146EF4 20-LEAD DUAL IN-LINE; PLASTIC

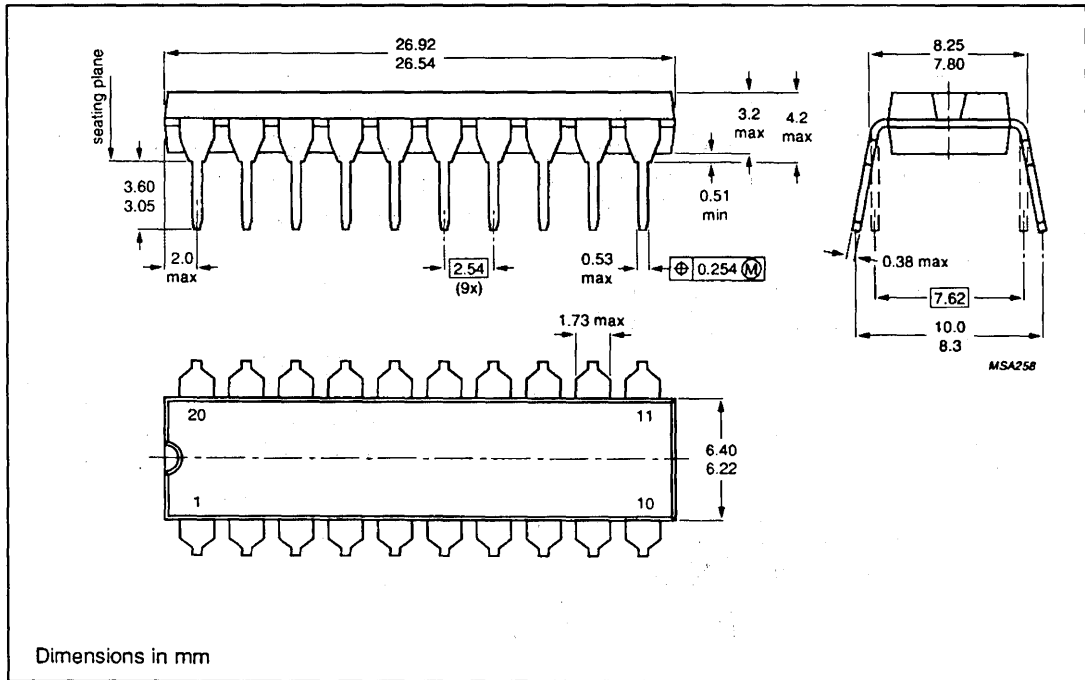

Dimensions in mm



# Package outlines

## SOT158A 40-PIN PLASTIC VSO (VERY SMALL OUTLINE) DUAL IN-LINE (D/T) PACKAGE

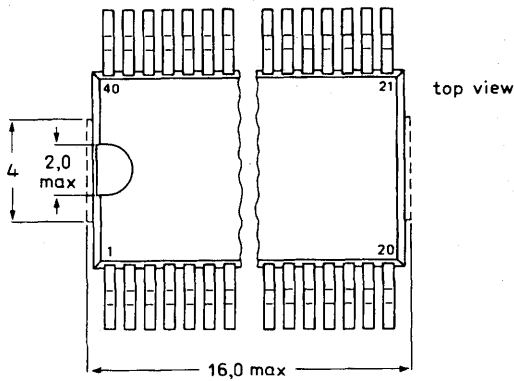
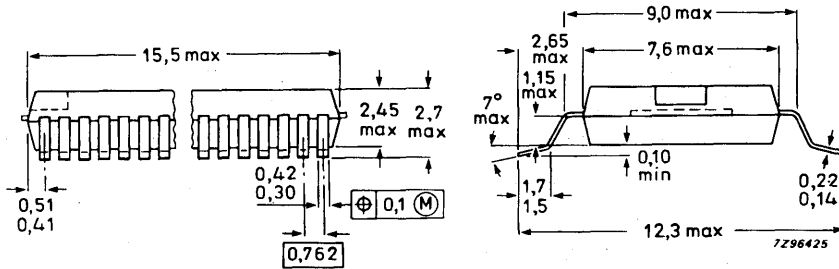

- ⊕ Positional accuracy.
- Ⓜ Maximum Material Condition.

Dimensions in mm

SOT 158A

7Z96425

# Package outlines

## SOT162-1 PLASTIC SMALL OUTLINE PACKAGE; 16 LEADS; LARGE BODY

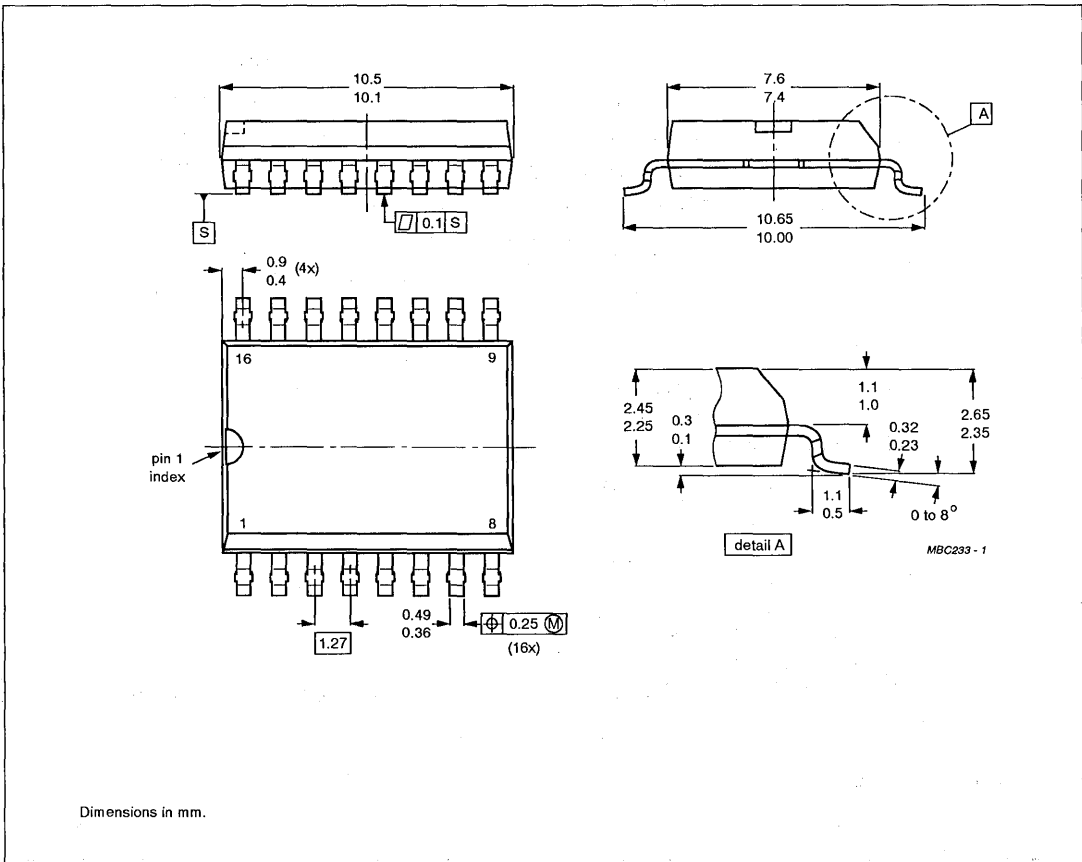

# Package outlines

## SOT163AG7 20-LEAD MINI-PACK; PLASTIC

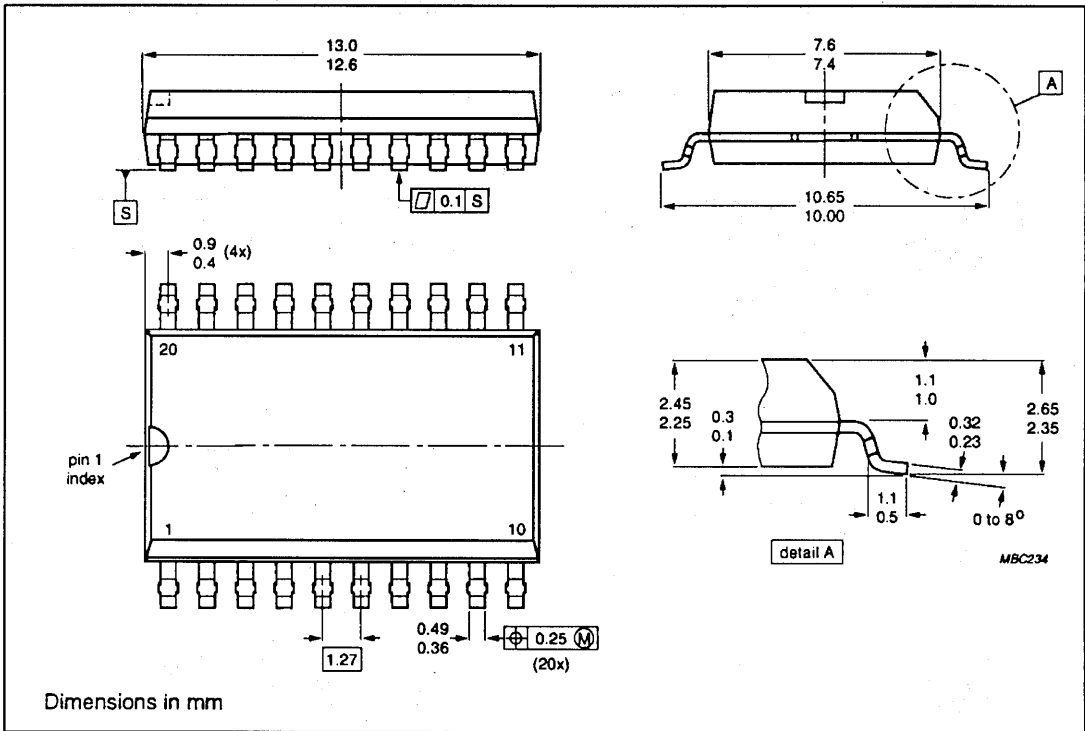

# Package outlines

## SOT187 44-PIN PLASTIC LEADED CHIP CARRIER; POCKET VERSION (A) PACKAGE

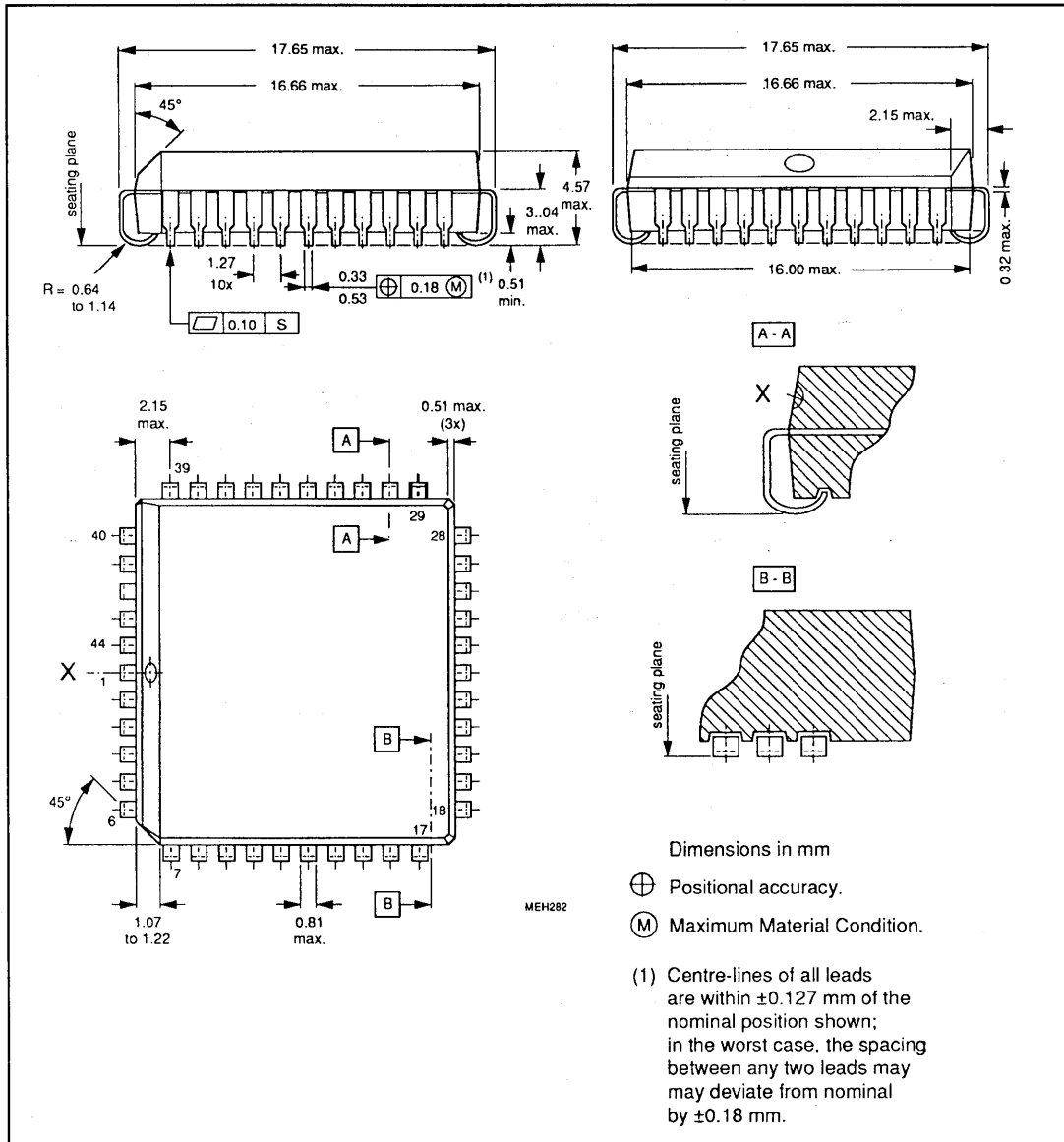

Package outlines

SOT188AA 68-PIN PLASTIC LEADED CHIP CARRIER; POCKET VERSION (A) PACKAGE

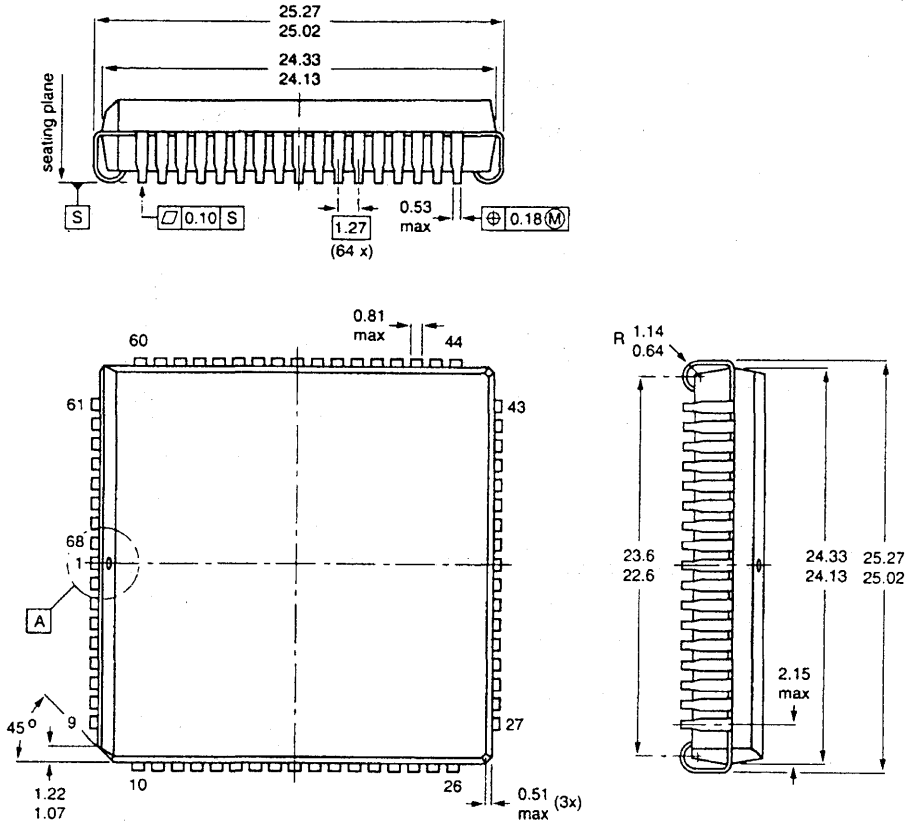

Dimensions in mm

detail A

MBC652

# Package outlines

## SOT189CG 84-PIN PLASTIC LEADED CHIP CARRIER (A) PACKAGE

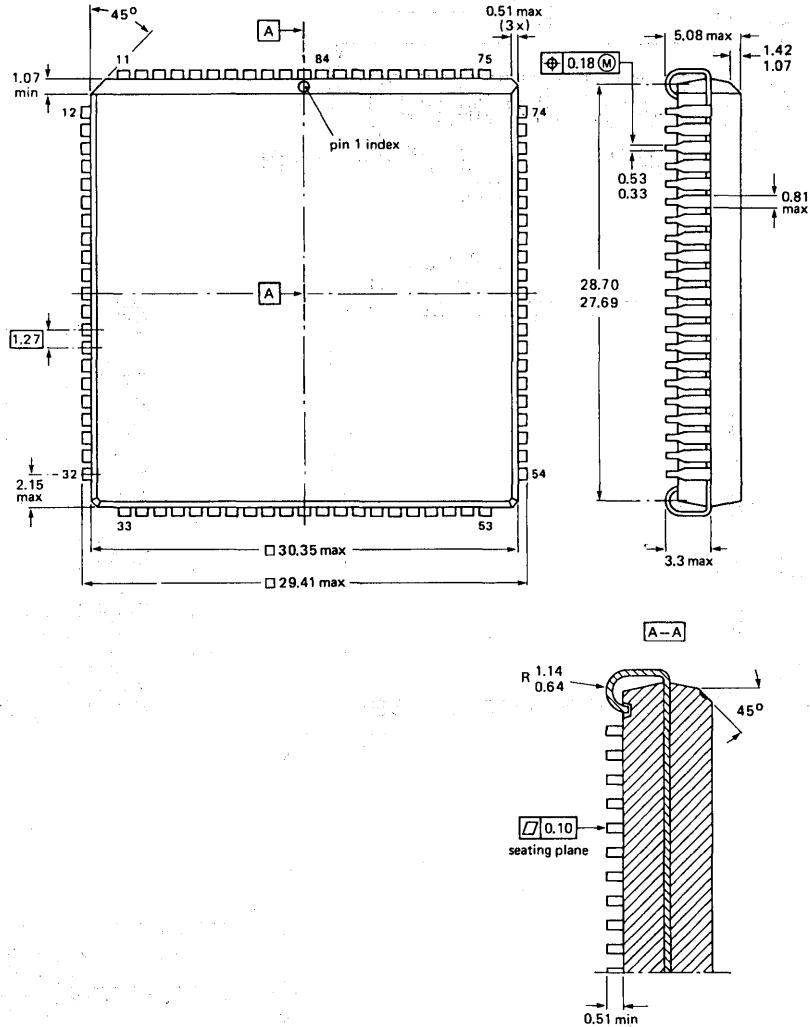

SOT189CG, AGA

7225140.1

# Package outlines

## SOT225 160-PIN PLASTIC QUAD FLAT PACK (H) PACKAGE

DIMENSIONS IN MM				
SYM	MIN	NOM	MAX	NOTE
A			4.01	
A1	0.25			
A2	3.17	3.42	3.65	
B	0.22		0.38	B
B1	0.22	0.30	0.33	
C	0.13		0.23	
C1		0.15±0.03		
D	31.00	31.20	31.40	4
D1		28.0±0.10		5
E		0.93		
E1	31.00	28.0±0.10	31.40	4
L1	0.73	0.88	1.03	5
L2		1.6 REF		
N		160		
Ø	0	0	7	
Ø1	0	0	8	
Ø2	8		12	
Ø3	8		12	
Ø4			0.10	

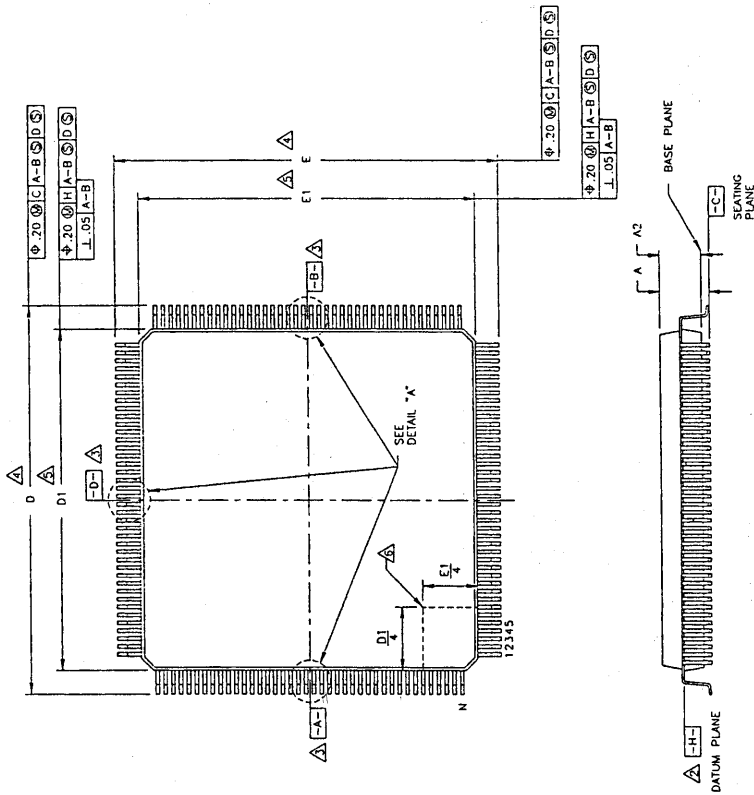

Package outlines

SOT1225 160-PIN PLASTIC QUAD FLAT PACK (Continued)

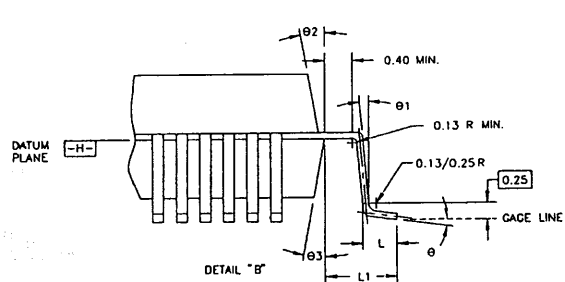

NOTES:

1. ALL DIMENSIONS AND TOLERANCES CONFORM TO ANSI Y14.5M-1982.
- △ DATUM PLANE -H- IS LOCATED AT THE MOLD PARTING LINE AND IS COINCIDENT WITH THE BOTTOM OF THE LEADS WHERE THE LEAD EXITS THE PLASTIC BODY.
- △ DATUMS A-B AND -D- TO BE DETERMINED AT DATUM PLANE -H-.
- △ TO BE DETERMINED AT SEATING PLANE -C-.
- △ DIMENSIONS D1 AND E1 DO NOT INCLUDE MOLD PROTRUSION. ALLOWABLE PROTRUSION IS .25mm/.010" PER SIDE. DIMENSIONS D1 AND E1 DO NOT INCLUDE MOLD MISMATCH AND ARE DETERMINED AT DATUM PLANE -H-.
- △ DETAILS OF PIN 1 IDENTIFIER ARE OPTIONAL BUT MUST BE LOCATED WITHIN THE ZONE INDICATED.
7. CONTROLLING DIMENSION: MILLIMETER.
- △ DIMENSION B DOES NOT INCLUDE DAMBAR PROTRUSION. ALLOWABLE DAMBAR PROTRUSION SHALL BE .08mm/.003" TOTAL IN EXCESS OF THE B DIMENSION AT MAXIMUM MATERIAL CONDITION. DAMBAR CANNOT BE LOCATED ON THE LOWER RADIUS OR THE FOOT. MINIMUM SPACING BETWEEN ADJACENT LEADS TO BE 0.10mm.
- △ MARKING AREA MUST BE FREE FROM PACKAGE SURFACE PROTRUSION OR INTRUSION.
- 10 PLATING THICKNESS INCLUDED. PLATING THICKNESS TO BE 0.005mm MINIMUM, 0.020mm MAXIMUM.

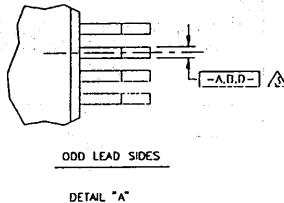
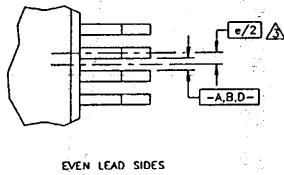
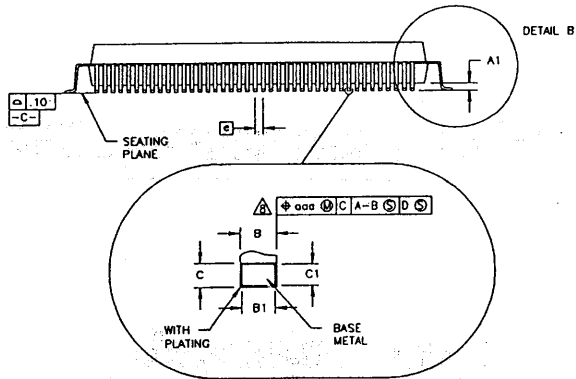



# Package outlines

## SOT232 32-PIN PLASTIC SHRINK DUAL IN-LINE (N/P) PACKAGE

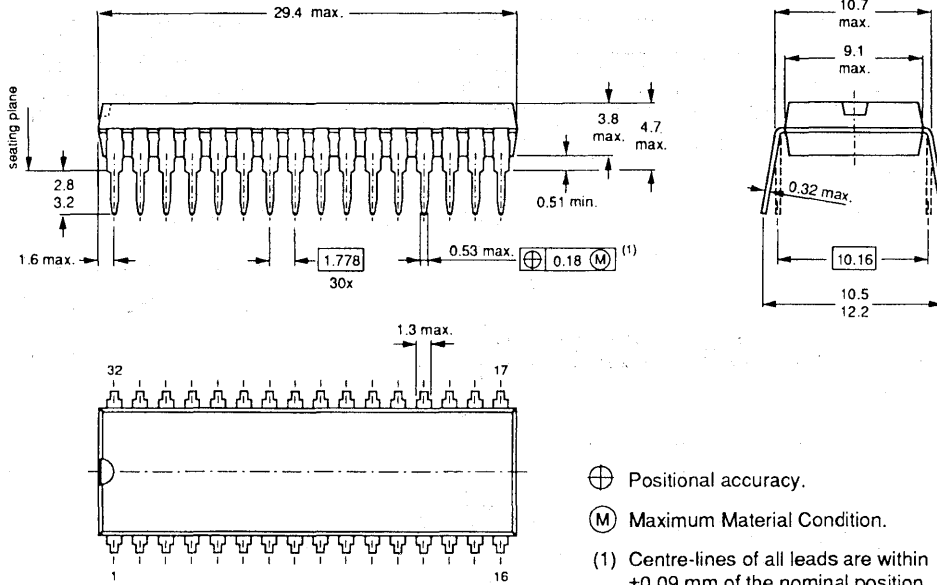

Dimensions in mm

⊕ Positional accuracy.

Ⓜ Maximum Material Condition.

(1) Centre-lines of all leads are within  $\pm 0.09$  mm of the nominal position shown; in the worst case, the spacing between any two leads may deviate from nominal by  $\pm 0.18$  mm.

OT232

# Package outlines

MSA263

## SOT234AG 24-LEAD PLASTIC SHRINK DUAL IN-LINE PACKAGE

MSA263

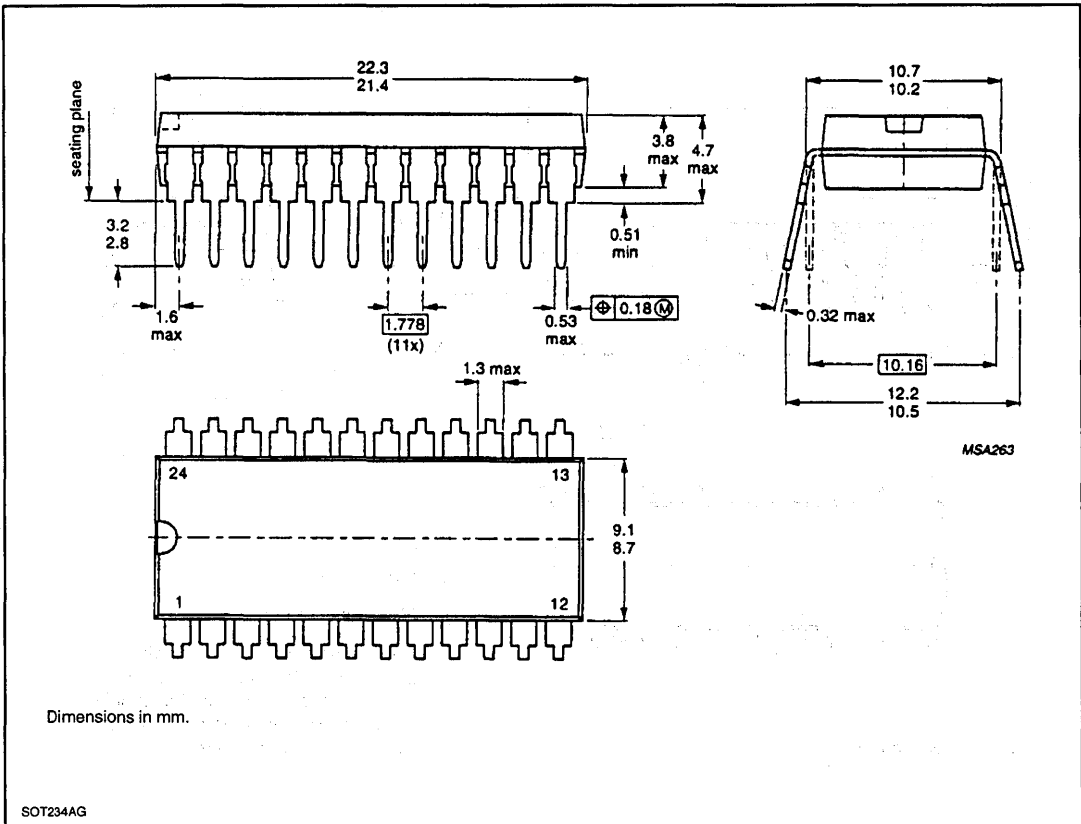

# Package outlines

## SOT247-1 52-PIN SHRINK DUAL IN-LINE PACKAGE; PLASTIC

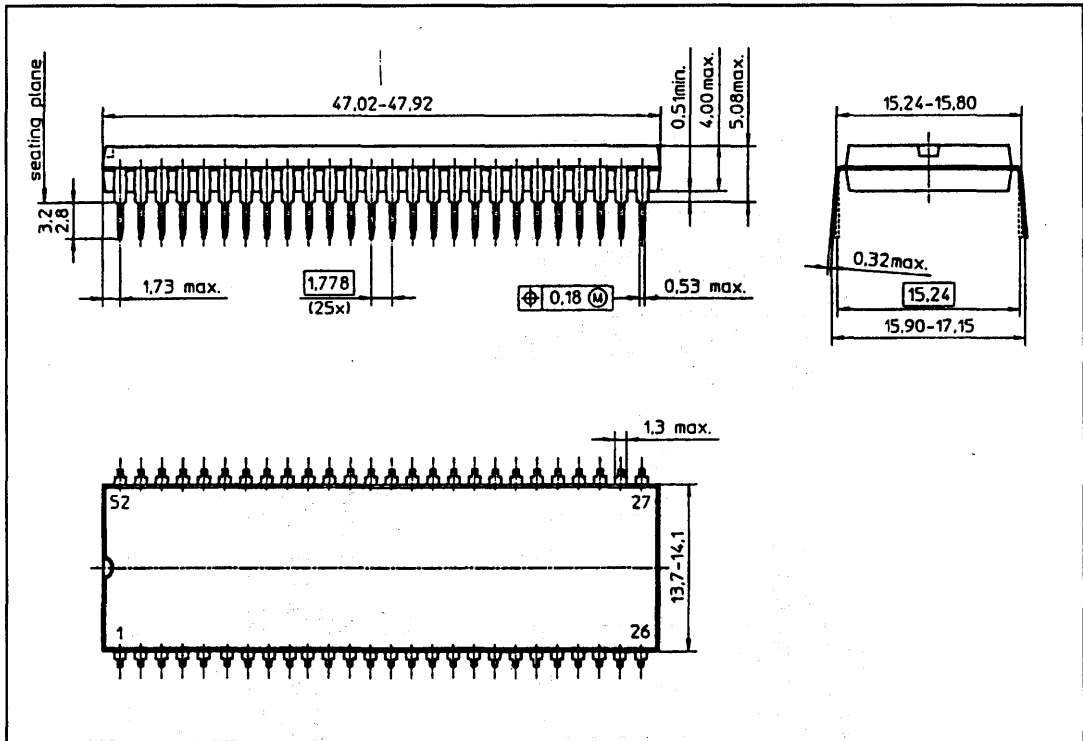

# Package outlines

## SOT261-2 PLASTIC LEADED CHIP CARRIER, 28 LEADS

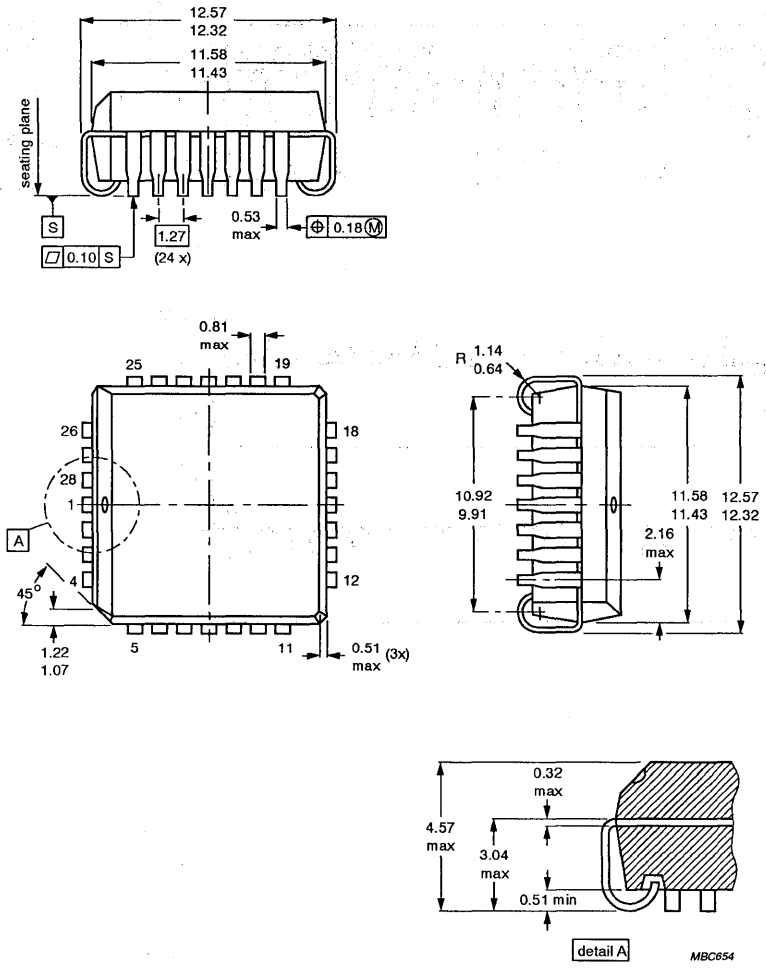

Dimensions in mm.

MBC854

# Package outlines

## SOT287-1 PLASTIC SMALL OUTLINE PACKAGE; 32 LEADS; LARGE BODY

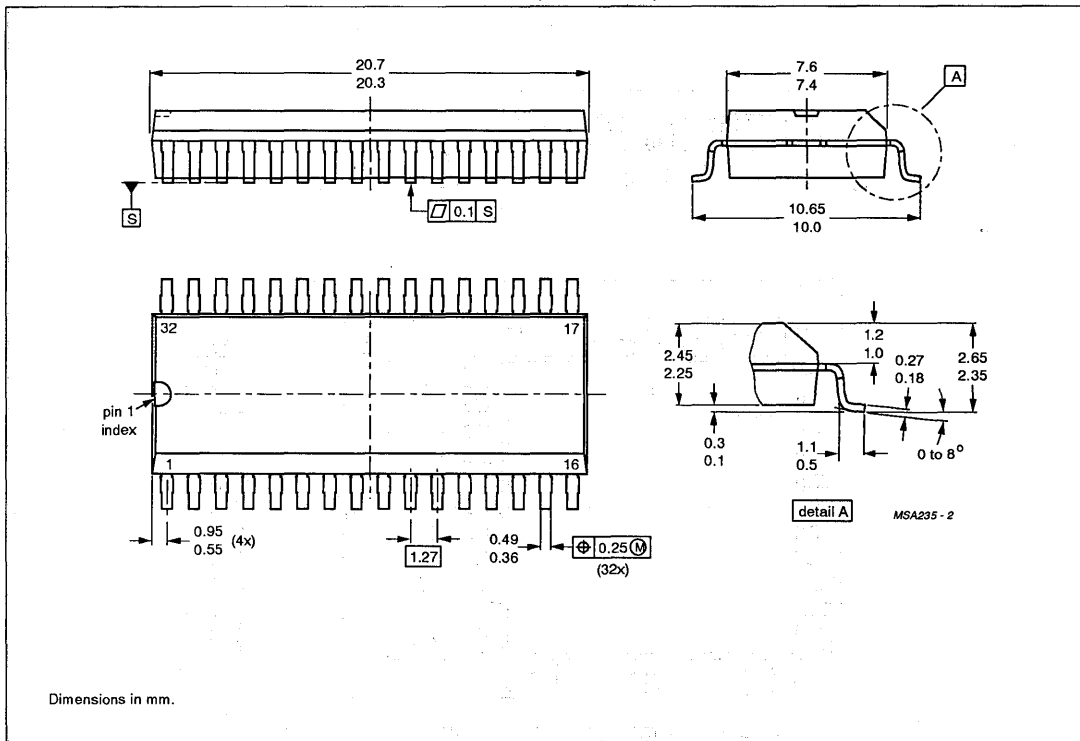

# Package outlines

## SOT307-2 44-PIN PLASTIC QUAD FLAT PACK (B) PACKAGE

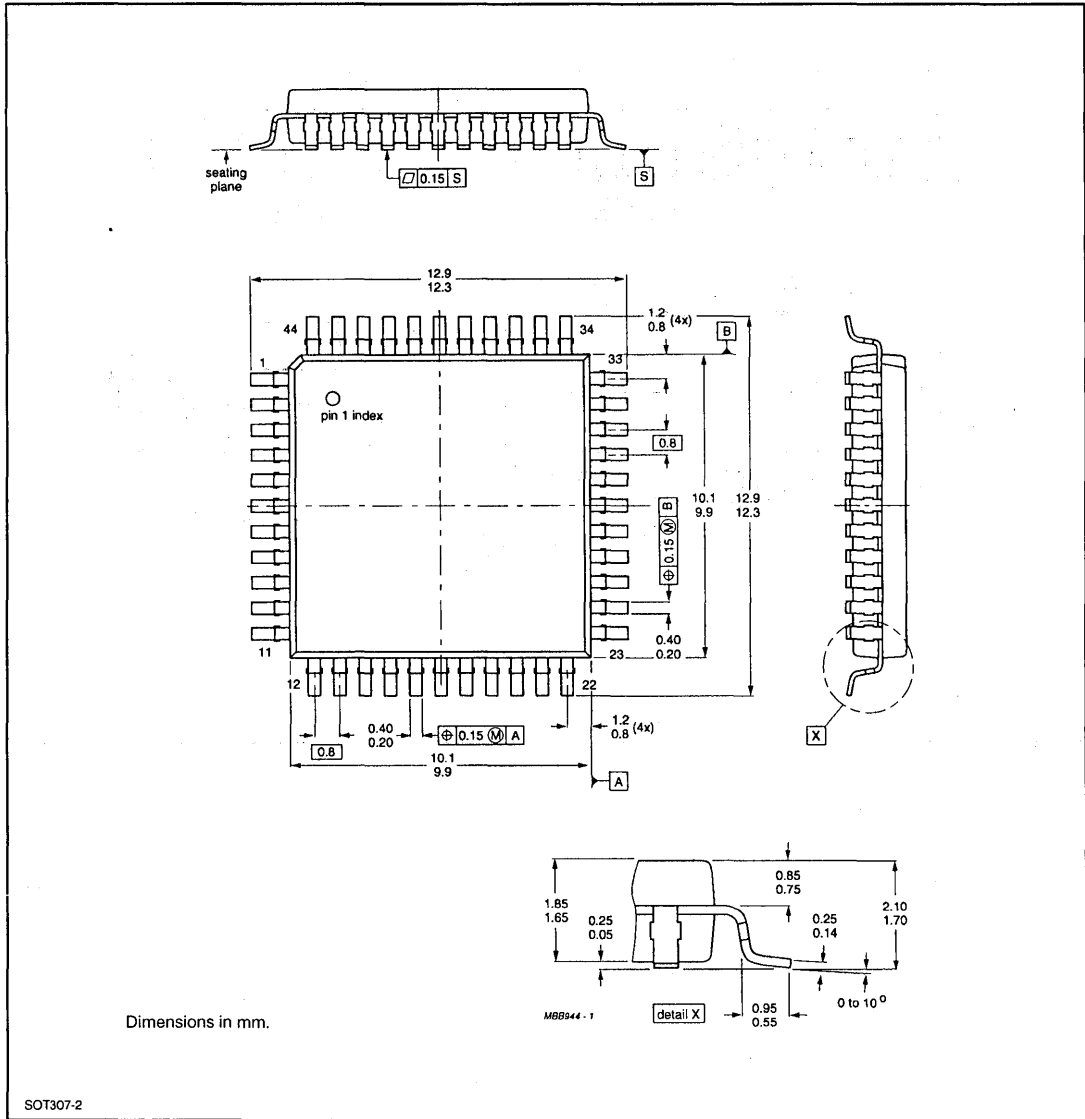

# Package outlines

## SOT313-2 PLASTIC THIN QUAD FLAT PACKAGE; 48 LEADS; 7 x 7 x 1.4 mm

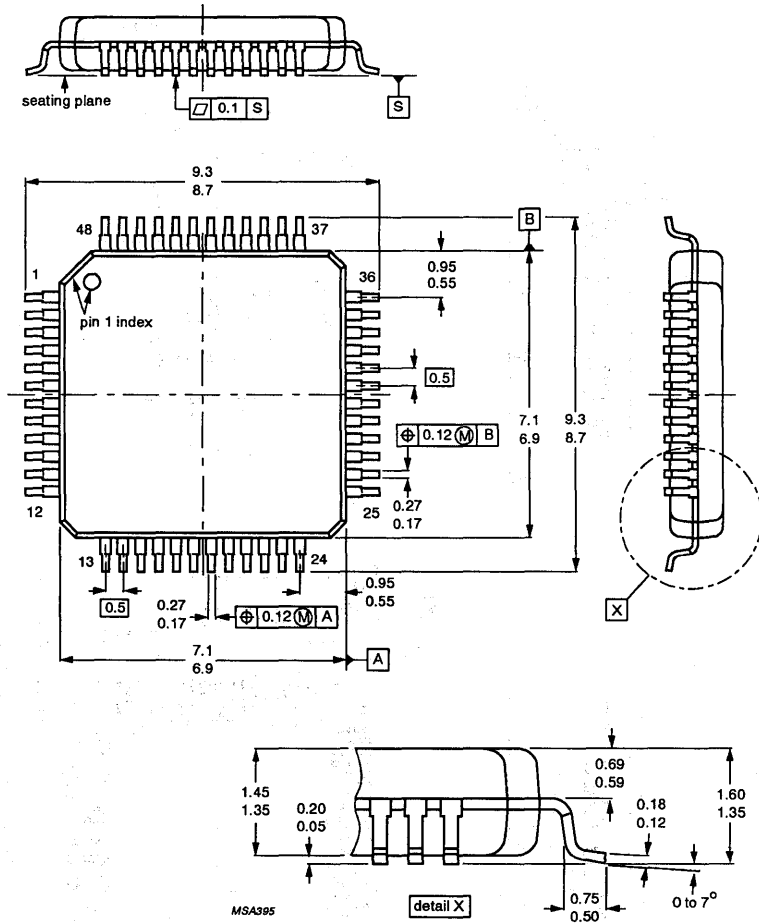

Dimensions in mm.

# Package outlines

## SOT317 100-PIN PLASTIC QUAD FLAT PACK (B) PACKAGE

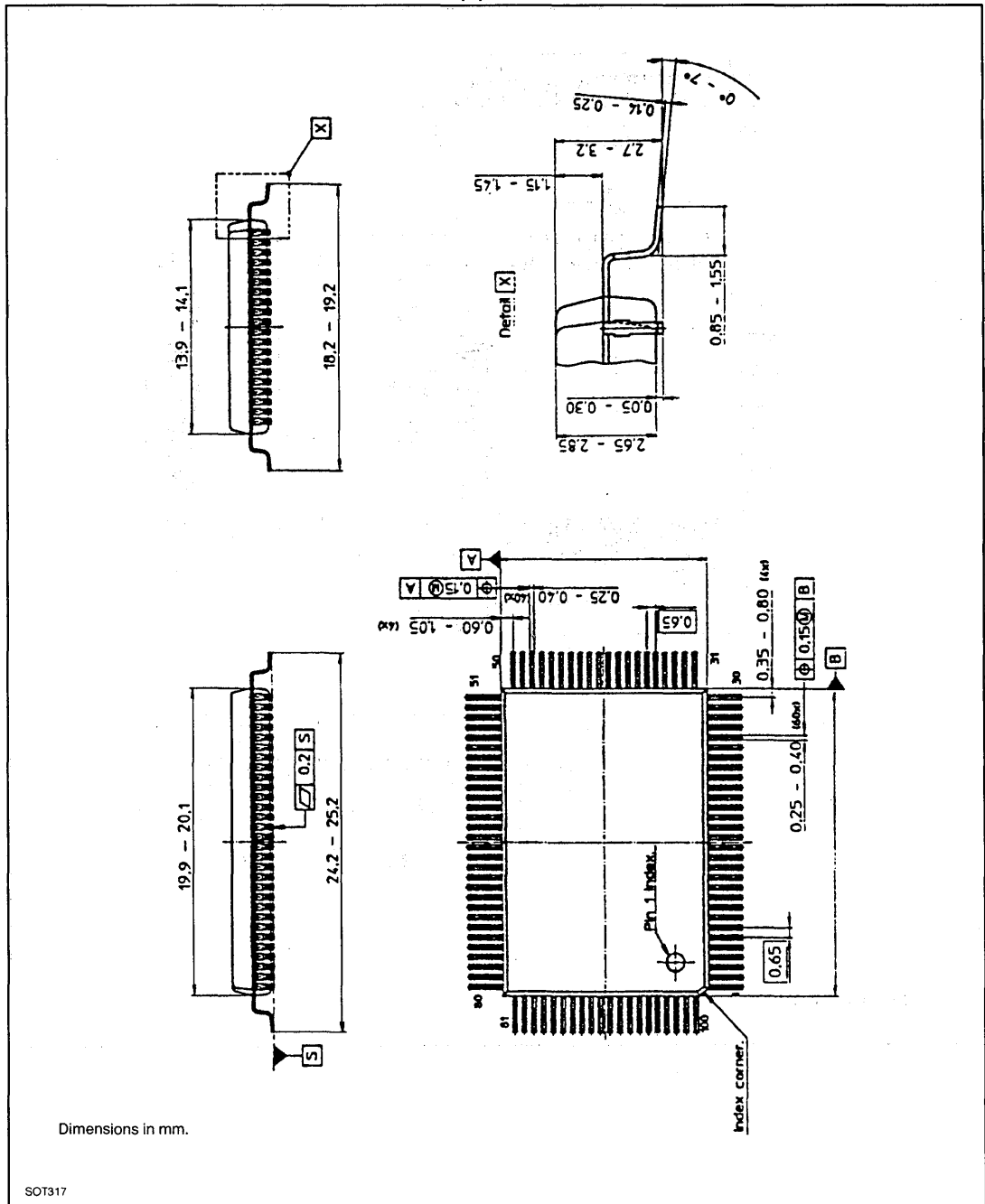



# Package outlines

## SOT318 80-PIN PLASTIC QUAD FLAT PACK (B) PACKAGE

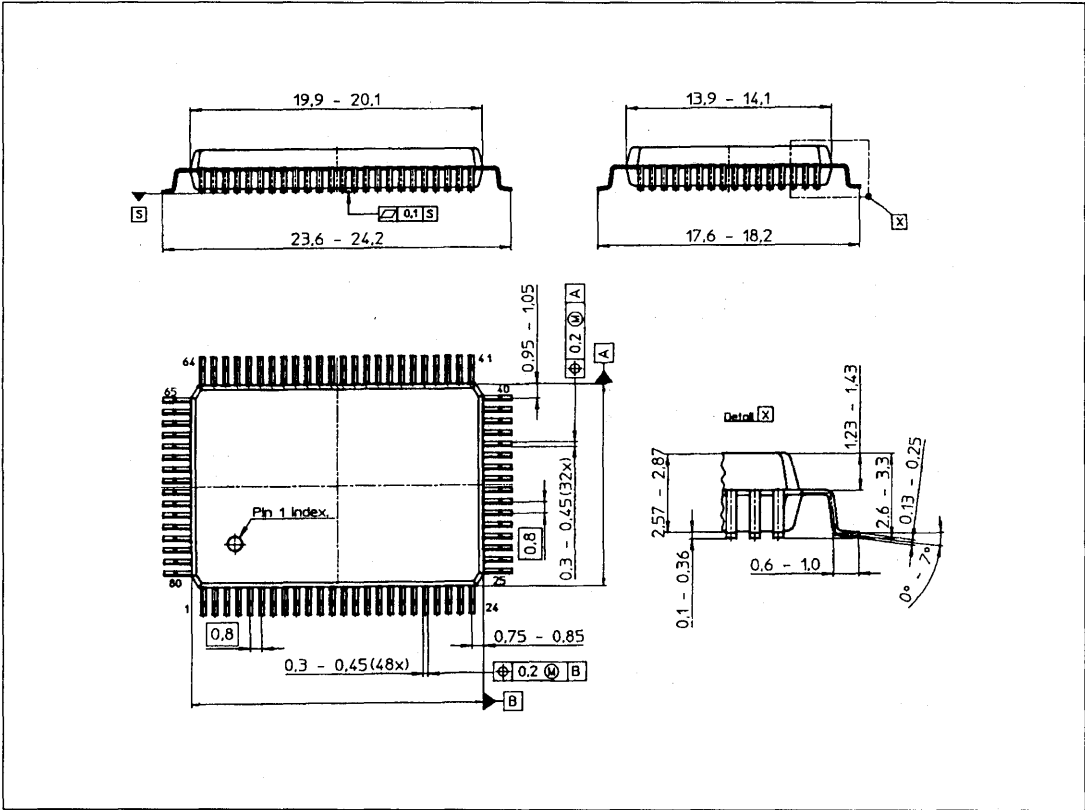

# Package outlines

## SOT340-1 PLASTIC SHRINK SMALL OUTLINE PACKAGE; 24 LEADS; MEDIUM BODY

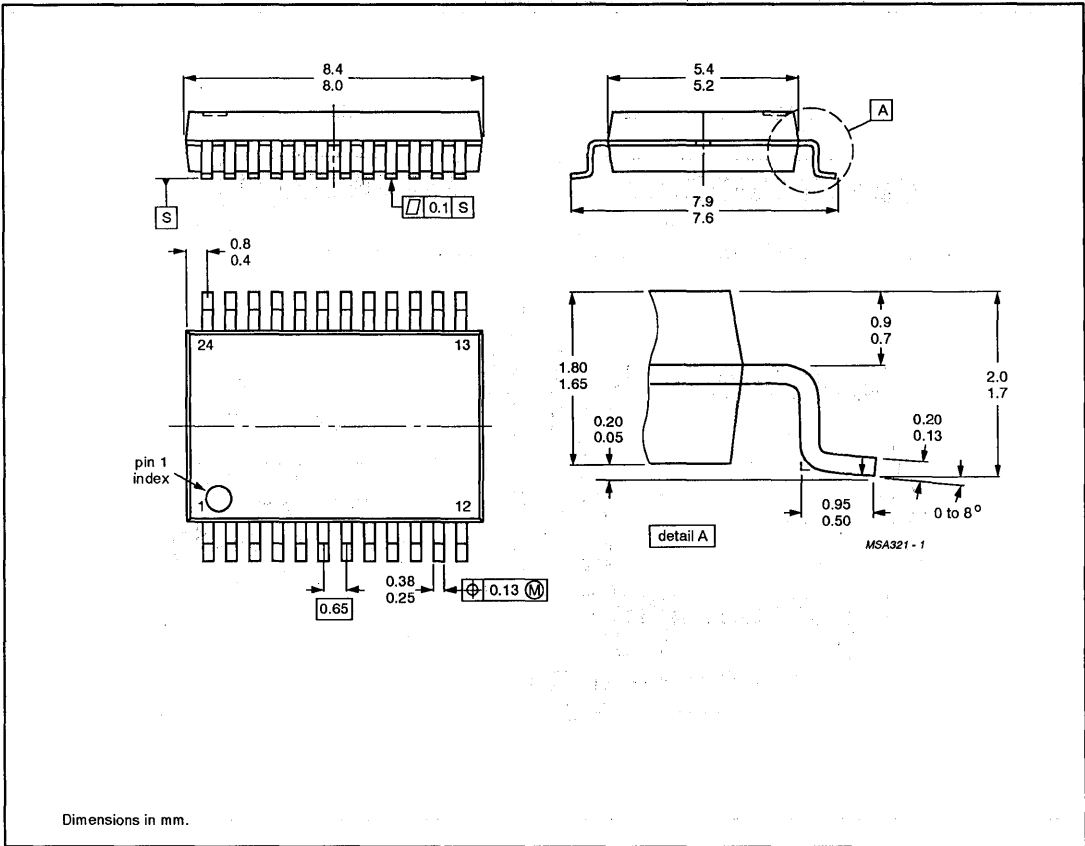





# Section 5

## Sales Offices, Representatives & Distributors



## North American Sales Offices, Representatives and Distributors

**PHILIPS SEMICONDUCTORS**  
811 East Arques Avenue  
P.O. Box 3409  
Sunnyvale, CA 94088-3409

**ALABAMA**  
**Huntsville**  
Philips Semiconductors  
Phone: (205) 464-0111  
(205) 464-9101

Elcom, Inc.  
Phone: (205) 830-4001

**ARIZONA**  
**Scottsdale**  
Thom Luke Sales, Inc.  
Phone: (602) 451-5400

**Tempe**  
Philips Semiconductors  
Phone: (602) 820-2225

**CALIFORNIA**  
**Calabasas**  
Philips Semiconductors  
Phone: (818) 880-6304

**Irvine**  
Philips Semiconductors  
Phone: (714) 453-0770

**Loomis**  
B.A.E. Sales, Inc.  
Phone: (916) 652-6777

**San Diego**  
Philips Semiconductors  
Phone: (619) 560-0242

**San Jose**  
B.A.E. Sales, Inc.  
Phone: (408) 452-8133

**Sunnyvale**  
Philips Semiconductors  
Phone: (408) 991-3737

**COLORADO**  
**Englewood**  
Philips Semiconductors  
Phone: (303) 792-9011  
Thom Luke Sales, Inc.  
Phone: (303) 649-9717

**CONNECTICUT**  
**Wallingford**  
JEBCO  
Phone: (203) 265-1318

**FLORIDA**  
**Oviedo**  
Conley and Assoc., Inc.  
Phone: (407) 365-3283

**GEORGIA**  
**Norcross**  
Elcom, Inc.  
Phone: (404) 447-8200

**ILLINOIS**  
**Hoffman Estates**  
Micro-Tex, Inc.  
Phone: (708) 765-3000

**Itasca**  
Philips Semiconductors  
Phone: (708) 250-0050

**INDIANA**  
**Indianapolis**  
Mohrfield Marketing, Inc.  
Phone: (317) 546-6969

**Kokomo**  
Philips Semiconductors  
Phone: (317) 459-5355

**KENTUCKY**  
**Lexington**  
Mohrfield Marketing, Inc.  
Phone: (606) 223-5243

**MARYLAND**  
**Columbia**  
Third Wave Solutions, Inc.  
Phone: (410) 290-5990

**MASSACHUSETTS**  
**Chelmsford**  
JEBCO  
Phone: (508) 256-5800

**Westford**  
Philips Semiconductors  
Phone: (508) 692-6211

**MICHIGAN**  
**Monroe**  
S-J Associates  
Phone: (313) 242-0450

**Novi**  
Philips Semiconductors  
Phone: (313) 347-1700

**MINNESOTA**  
**Bloomington**  
High Technology Sales  
Phone: (612) 844-9933

**MISSOURI**  
**Bridgeton**  
Centech, Inc.  
Phone: (314) 291-4230

**Raytown**  
Centech, Inc.  
Phone: (816) 358-8100

**NEW JERSEY**  
**Toms River**  
Philips Semiconductors  
Phone: (908) 505-1200

**NEW YORK**  
**Ithaca**  
Bob Dean, Inc.  
Phone: (607) 257-1111

**Rockville Centre**  
S-J Associates  
Phone: (516) 536-4242

**Wappingers Falls**  
Philips Semiconductors  
Phone: (914) 297-4074

Bob Dean, Inc.  
Phone: (914) 297-6406

**NORTH CAROLINA**  
**Charlotte**  
Elcom, Inc.  
Phone: (704) 543-1229

**Greensboro**  
Elcom, Inc.  
Phone: (919) 273-8887

**Matthews**  
Elcom, Inc.  
Phone: (704) 847-4323

**OHIO**  
**Chardon**  
S-J Associates, Inc.  
Phone: (216) 285-7771

**Columbus**  
S-J Associates, Inc.  
Phone: (614) 885-6700

**Kettering**  
S-J Associates, Inc.  
Phone: (513) 298-7322

**Parma**  
S-J Associates, Inc.  
Phone: (216) 888-7004

**Toledo**  
S-J Associates, Inc.  
Phone: (313) 242-0450

**West Carrollton**  
S-J Associates, Inc.  
Phone: (513) 438-1700

**OREGON**  
**Beaverton**  
Philips Semiconductors  
Phone: (503) 627-0110

Western Technical Sales  
Phone: (503) 644-8860

**PENNSYLVANIA**  
**Erie**  
S-J Associates, Inc.  
Phone: (216) 888-7004

**Hatboro**  
Delta Technical Sales, Inc.  
Phone: (215) 957-0600

**Pittsburgh**  
S-J Associates, Inc.  
Phone: (216) 888-7004

**Plymouth Meeting**  
Philips Semiconductors  
Phone: (215) 825-4404

**SOUTH CAROLINA**  
**Greenville**  
Elcom, Inc.  
Phone: (803) 370-9119

**TENNESSEE**  
**Dandridge**  
Philips Semiconductors  
Phone: (615) 397-5053

**TEXAS**  
**Austin**  
Philips Semiconductors  
Phone: (512) 339-9945

**Austin**  
Synergistic Sales, Inc.  
Phone: (512) 346-2122

**Houston**  
Synergistic Sales, Inc.  
Phone: (713) 937-1990

**Richardson**  
Philips Semiconductors  
Phone: (214) 644-1610

**Richardson**  
Synergistic Sales, Inc.  
Phone: (214) 644-3500

**UTAH**  
**Salt Lake City**  
Electrodyne  
Phone: (801) 264-8050

**WASHINGTON**  
**Bellevue**  
Western Technical Sales  
Phone: (206) 641-3900  
**Spokane**  
Western Technical Sales  
Phone: (509) 922-7600

**WISCONSIN**  
**Waukesha**  
Micro-Tex, Inc.  
Phone: (414) 542-5352

**CANADA**  
**PHILIPS SEMICONDUCTORS CANADA, LTD.**

**Calgary, Alberta**  
Tech-Trek, Ltd.  
Phone: (403) 241-1719

**Kanata, Ontario**  
Philips Semiconductors  
Phone: (613) 599-8720

Tech-Trek, Ltd.  
Phone: (613) 599-8787

**Mississauga, Ontario**  
Tech-Trek, Ltd.  
Phone: (416) 238-0366

**Richmond, B.C.**  
Tech-Trek, Ltd.  
Phone: (604) 276-8735

**Scarborough, Ontario**  
Philips Semiconductors/  
Components, Ltd.  
(416) 292-5161

**Ville St. Laurent, Quebec**  
Tech-Trek, Ltd.  
Phone: (514) 337-7540

**MEXICO**  
**Anzures Section**  
Philips Components  
Phone: (800) 234-7381

**El Paso, TX**  
Philips Components  
Phone: (915) 775-4020

**PUERTO RICO**  
**Caguas**  
Mectron Group  
Phone: (809) 746-3522

### DISTRIBUTORS

**Contact one of our local distributors:**  
Anthem Electronics  
Arrow/Schweber Electronics  
Future Electronics (Canada only)  
Gerber Electronics  
Hamilton Hallmark/  
Allied Electronics  
Marshall Industries  
Newark Electronics  
Richardson Electronics  
Wyle Laboratories, EMG







**DATA HANDBOOK SYSTEM**

Philips Semiconductors data handbooks contain all pertinent data available at the time of publication and each is revised and reissued regularly.

Loose data sheets are sent to subscribers to keep them up-to-date on additions or alterations made during the lifetime of a data handbook.

Catalogs are available for selected product ranges (some catalogs are also on floppy discs).

Our data handbook titles are listed here.

**Integrated Circuits**

<i>Book</i>	<i>Title</i>
IC01	Semiconductors for Radio and Audio Systems
IC02	Semiconductors for Television and Video Systems
IC03	Semiconductors for Telecom Systems
IC04	CMOS HE4000B Logic Family
IC05	Advanced Low-power Schottky (ALS) Logic Series
IC06	High-speed CMOS Logic Family
IC08	100K ECL Logic Families
IC10	Memories
IC11	General-purpose/Linear ICs
IC12	Display Drivers and Microcontroller Peripherals (planned)
IC13	Programmable Logic Devices (PLD)
IC14	8048-based 8-bit Microcontrollers
IC15	FAST TTL Logic Series
IC16	ICs for Clocks and Watches
IC18	Semiconductors for In-car Electronics and General Industrial Applications (planned)
IC17	RF/Wireless Communications
IC19	Semiconductors for Datacom: LANs, UARTs, Multi-protocol Controllers and Fibre Optics
IC20	80C51-based 8-bit Microcontrollers
IC21	68000-based 16-bit Microcontrollers (planned)
IC22	ICs for Multi-media Systems (planned)
IC23	QUBIC Advanced BiCMOS Bus Interface Logic ABT, MULTIBYTE™
IC24	Low Voltage CMOS & BiCMOS Logic

**Discrete Semiconductors**

<i>Book</i>	<i>Title</i>
SC01	Diodes
SC02	Power Diodes
SC03	Thyristors and Triacs
SC04	Small-signal Transistors
SC05	Low-frequency Power Transistors and Hybrid IC Power Modules
SC06	High-voltage and Switching NPN Power Transistors
SC07	Small-signal Field-effect Transistors
SC08a	RF Power Bipolar Transistors
SC08b	RF Power MOS Transistors
SC09	RF Power Modules
SC10	Surface Mounted Semiconductors
SC13	Power MOS Transistors including TOPFETs and IGBTs
SC14	RF Wideband Transistors, Video Transistors and Modules
SC15	Microwave Transistors
SC16	Wideband Hybrid IC Modules
SC17	Semiconductor Sensors

**Professional Components**

PC01	High-power Klystrons and Accessories
PC06	Circulators and Isolators

**MORE INFORMATION FROM PHILIPS SEMICONDUCTORS?**

For more information about Philips Semiconductors data handbooks, catalogs and subscriptions contact your nearest Philips Semiconductors national organization, select from the **address list on the back cover of this handbook**. Product specialists are at your service and inquiries are answered promptly.

## OVERVIEW OF PHILIPS COMPONENTS DATA HANDBOOKS

Our sister product division, Philips Components, also has a comprehensive data handbook system to support their products. Their data handbook titles are listed here.

### Display Components

Book	Title
DC01	Colour Display Components Colour TV Picture Tubes and Assemblies Colour Monitor Tube Assemblies
DC02	Monochrome Monitor Tubes and Deflection Units
DC03	Television Tuners, Coaxial Aerial Input Assemblies
DC05	Flyback Transformers, Mains Transformers and General-purpose FXC Assemblies

### Magnetic Products

MA01	Soft Ferrites
MA03	Piezoelectric Ceramics Specialty Ferrites
MA04	Dry-reed Switches

### Passive Components

PA01	Electrolytic Capacitors
PA02	Varistors, Thermistors and Sensors
PA03	Potentiometers and Switches
PA04	Variable Capacitors
PA05	Film Capacitors
PA06	Ceramic Capacitors
PA07	Quartz Crystals for Special and Industrial Applications
PA08	Fixed Resistors
PA10	Quartz Crystals for Automotive and Standard Applications
PA11	Quartz Oscillators

### Professional Components

PC04	Photo Multipliers
PC05	Plumbicon Camera Tubes and Accessories
PC07	Vidicon and Newvicon Camera Tubes and Deflection Units
PC08	Image Intensifiers
PC12	Electron Multipliers

## MORE INFORMATION FROM PHILIPS COMPONENTS?

For more information contact your nearest Philips Components national organization shown in the following list.

<b>Argentina:</b> BUENOS AIRES, Tel. (541) 786 7633, Fax. (541) 786 9367.
<b>Australia:</b> NORTH RYDE, Tel. (02) 805 4455, Fax. (02) 805 4466.
<b>Austria:</b> WIEN, Tel. (01) 60 101-1236, Fax. (01) 60 101-1211.
<b>Belgium:</b> EINDHOVEN, The Netherlands, Tel. (31)40 783 749, Fax. (31)40 788 399.
<b>Brazil:</b> SÃO PAULO, Tel. (011) 829-1166, Fax (011) 829-1849.
<b>Canada:</b> INTEGRATED CIRCUITS: Tel. (800) 234-7381, Fax. (708) 296-8556 DISCRETE SEMICONDUCTORS: SCARBOROUGH Tel. (0416) 292-5161 ext. 2336, Fax. (0416) 292-4477
<b>Chile:</b> SANTIAGO, Tel. (02) 773 816, Fax. (02) 777 6730.
<b>Columbia:</b> BOGOTA, Tel. (571)217 4609, Fax (01) 217 4549.
<b>Denmark:</b> COPENHAGEN, Tel. (032) 88 2636, Fax. (031) 57 1949.
<b>Finland:</b> ESPOO, Tel. (9)0 50261, Fax. (9)0 520971.
<b>France:</b> SURESNES, Tel. (01)4099 6161, Fax, (01)4099 6427.
<b>Germany:</b> HAMBURG, Tel. (040) 3296-0, Fax. (040) 3296 213.
<b>Greece:</b> TAVROS, Tel. (01) 4894 339/4894 911, Fax. (01) 4814 240.
<b>Hong Kong:</b> KWAI CHUNG, Tel. (0)42 45 121, Fax. (0) 4806 960.
<b>India:</b> BOMBAY, Tel. (022) 4938 541, Fax. (022) 4938 722.
<b>Indonesia:</b> JAKARTA, Tel. (021) 5201 122, Fax. (021) 5205 189.
<b>Ireland:</b> DUBLIN, Tel. (01) 640 000, Fax. (01) 640 200.
<b>Italy:</b> MILANO, Tel. (02) 6752.1, Fax. (02) 6752.3350.
<b>Japan:</b> TOKYO, Tel. (03) 3740 5101, Fax. (03) 3740 0570.
<b>Korea (Republic of):</b> SEOUL, SEUL, Tel. (02) 794-5011, Fax. (02) 798-8022.
<b>Malaysia:</b> SELANGOR, Tel. (03) 757 5511, Fax. (03) 757 4880.
<b>Mexico:</b> EL PASO, TX 79905, Tel. 9-5(800) 234-7381, Fax. (708) 296-8556
<b>Netherlands:</b> EINDHOVEN, Tel. (040) 78 37 49, Fax. (040)78 83 99.
<b>New Zealand:</b> AUKLAND, Tel. (09) 849-4160, Fax. (09) 849-7811.
<b>Norway:</b> OSLO, Tel. (22) 74 8000, Fax (22)74 8341.
<b>Pakistan:</b> KARACHI, Tel. (021) 577 039, Fax. (021) 569 1832.
<b>Philippines:</b> MANILA, Tel. (02) 810 0161, Fax. (02) 817 3474.
<b>Portugal:</b> LISBOA, Tel. (01) 683 121, Fax. (01) 658 013.
<b>Singapore:</b> SINGAPORE, Tel. (65) 350 2000, Fax. (65) 251 6500.
<b>South Africa:</b> JOHANNESBURG, Tel. (011) 470-5433, Fax. (011) 470-5494.
<b>Spain:</b> BARCELONA, Tel. (03) 301 6312, Fax. (03) 301 4243.
<b>Sweden:</b> STOCKHOLM, Tel. (0)8-632 2000, Fax. (0)8-632 2745.
<b>Switzerland:</b> ZÜRICH, Tel. (01) 488 2211, Fax. (01) 481 7730.
<b>Taiwan:</b> TAIPEI, Tel. (2) 388 7666, Fax. (2)382 4382.
<b>Thailand:</b> BANGKOK, Tel. (2)399-3280 to 9, (2)398-2083, Fax. (2)398-2080.
<b>Turkey:</b> ISTANBUL, Tel. (0212) 279 2770, Fax. (0212) 269 3094.
<b>United Kingdom:</b> LONDON, Tel. (071) 436 4144, Fax. (071) 323 0342.
<b>United States:</b> INTEGRATED CIRCUITS: SUNNYVALE, CA Tel. (800) 234-7381, Fax. (708) 296-8556 DISCRETE SEMICONDUCTORS: RIVIERA BEACH, FL Tel. (800) 447-3762 and (407)881-3200, Fax. (407) 881-3300
<b>Uruguay:</b> MONTEVIDEO, Tel. (02) 70-4044, Fax (02) 92 0601.
For all other countries apply to: <b>Philips Components</b> , Marketing Communications, Building BAF-1, P.O. Box 218, 5600 MD, EINDHOVEN, The Netherlands Telex 35000 phtcnl, Fax. +31-40-724825.



# Philips Semiconductors – a worldwide company

Argentina: IEROD, Av. Juramento 1992 - 14.b (1428) BUENOS AIRES,  
Tel. (541) 786 7633, Fax. (541) 786 9367

Australia: 34 Waterloo Road, NORTH RYDE, NSW 2113,  
Tel. (02) 805 4455, Fax. (02) 805 4466

Austria: Triester Str. 64, A-1101 WIEN, P.O. Box 213,  
Tel. (01) 60 101-1236, Fax. (01) 60 101-1211

Belgium: Postbus 90050, 5600 PB EINDHOVEN, The Netherlands,  
Tel. (31)40 783 749, Fax. (31)40 788 399

Brazil: Rua do Rocio 220 - 5th Floor, Suite 51  
CEP: 04552-903 SÃO PAULO-SP, Brazil  
P.O. Box 7383-(01064-970),  
Tel. (011) 821-2333, Fax (011) 829-1849

Canada: PHILIPS SEMICONDUCTORS/COMPONENTS:  
Tel. (800) 234-7381, Fax. (708) 296-8556

Chile: Av. Santa Maria 0760, SANTIAGO,  
Tel. (02) 773 816, Fax. (02) 777 6730

Colombia: IPRELENZO LTDA, Carrera 21 No. 56-17, 77621 BOGOTA,  
Tel. (571)249 7624/(571)217 4609, Fax. (571)217 4549

Denmark: Prags Boulevard 80, PB 1919, DK-2300 COPENHAGEN S,  
Tel. (032) 88 2636, Fax. (031) 57 1949

Finland: Sinikalliontie 3, FIN-02630 ESPOO,  
Tel. (9)0 50261, Fax. (9)0 520971

France: 4 Rue du Port-aux-Vins, BP317, 92156 SURESNES Cedex,  
Tel. (01)4099 6161, Fax. (01)4099 6427

Germany: PHILIPS COMPONENTS UB der Philips G.m.b.H.,  
P.O. Box 10 63 23, 20043 HAMBURG,  
Tel. (040) 3296-0, Fax. (040) 3296 213

Greece: No. 15, 25th March Street, GR 17778 TAVROS,  
Tel. (01) 4894 339/4894 911, Fax. (01) 4814 240

Hong Kong: PHILIPS HONG KONG Ltd., Components Div.,  
6/F Philips Ind. Bldg., 24-28 Kung Yip St., KWAI CHUNG, N.T.,  
Tel. (852)424 5121, Fax. (852)428 6729

India: Philips INDIA Ltd., Components Dept., Shivsagar Estate, A Block,  
Dr. Annie Besant Rd., Worli, BOMBAY 400 018,  
Tel. (022)4938 541, Fax. (022)4938 722

Indonesia: Philips House, Jalan H.R. Rasuna Said Kav. 3-4,  
P.O. Box 4252, JAKARTA 12950  
Tel. (021)5201 122, Fax. (021)5205 189

Ireland: Newstead, Clonskeagh, DUBLIN 14,  
Tel. (01)640 000, Fax. (01)640 200

Italy: PHILIPS COMPONENTS S.r.l., Viale F. Testi, 327, 20162 MILANO,  
Tel. (02)6752.3302, Fax. (02)6752.3300

Japan: Philips Bldg. 13-37, Kohnan 2-chome, Minato-ku, TOKYO 108,  
Tel. (03)3740 5028, Fax. (03) 3740 0580

Korea (Republic of): Philips House, 260-199 Itaewon-dong,  
Yongsan-ku, SEOUL, Tel. (02)794-5011, Fax. (02)798-8022

Malaysia: No. 76 Jalan Universiti, 46200 PETALING JAYA,  
SELANGOR, Tel. (03)750 5214, Fax. (03)757 4880

Mexico: Philips Components, 5900 Gateway East, Suite 200,  
EL PASO, TX 79905, Tel. 9-5 (800)234-7381, Fax. (708)296-8556

Netherlands: Postbus 90050, 5600 PB EINDHOVEN, Bldg. VB  
Tel. (040)783749, Fax. (040)788399

New Zealand: 2 Wagener Place, C.P.O. Box 1041, AUCKLAND,  
Tel. (09)849-4160, Fax. (09)849-7811

Norway: Box 1, Manglerud 0612, OSLO,  
Tel. (022)74 8000, Fax (022)74 8341

Pakistan: Philips Electrical Industries of Pakistan Ltd.,  
Exchange Bldg. ST-2/A, Block 9, KDA Scheme 5, Clifton,  
KARACHI 75600, Tel. (021)587 4641-49, Fax. (021)577035/5874546

Philippines: PHILIPS SEMICONDUCTORS PHILIPPINES Inc.,  
106 Valero St. Salcedo Village, P.O. Box 2108 MCC, MAKATI,  
Metro MANILA, Tel. (02)810 0161, Fax. (02)817 3474

Portugal: PHILIPS PORTUGUESA, S.A.,  
Rua dr. Ant3nio Loureiro Borges 5, Arquiparque - Miraflores,  
Apartado 300, 2795 LINDA-A-VELHA,  
Tel. (01)14163160/4163333, Fax. (01)14163174/4163366

Singapore: Lorong 1, Toa Payoh, SINGAPORE 1231,  
Tel. (65)350 2000, Fax. (65)251 6500

South Africa: S.A. PHILIPS Pty Ltd., Components Division,  
195-215 Main Road, Martindale, 2092 JOHANNESBURG,  
P.O. Box 7430, Johannesburg 2000,  
Tel. (011)470-5911, Fax. (011)470-5494

Spain: Balmes 22, 08007 BARCELONA,  
Tel. (03)301 6312, Fax. (03)301 4243

Sweden: Kottbygatan 7, Akalla. S-164 85 STOCKHOLM,  
Tel. (0)8-632 2000, Fax. (0)8-632 2745

Switzerland: Allmendstrasse 140, CH-8027 ZÜRICH,  
Tel. (01)488 2211, Fax. (01)481 7730

Taiwan: PHILIPS TAIWAN Ltd., 23-30F, 66, Chung Hsiao West Road,  
Sec. 1, Taipei, Taiwan ROC, P.O. Box 22978, TAIPEI 100,  
Tel. (02)388 7666, Fax. (02)382 4382

Thailand: PHILIPS ELECTRONICS (THAILAND) Ltd.,  
209/2 Sanpavuth-Bangna Road Prakanong,  
BANGKOK 10260, Thailand  
Tel. (662)398-0141, Fax. (662)398-3319

Turkey: Talatpasa Cad. No. 5, 80640 GÜLTEPE/ISTANBUL,  
Tel. (0212)279 2770, Fax. (0212)269 3094

United Kingdom: Philips Semiconductors Limited, P.O. Box 65,  
Philips House, Torrington Place, LONDON WC1E 7HD,  
Tel. (071)436 4144, Fax. (071)323 0342

United States: 811 East Arques Avenue, SUNNYVALE, CA 94088-3409,  
Tel. (800)234-7381, Fax. (708)296-8556

Uruguay: Coronel Mora 433, MONTEVIDEO,  
Tel. (02)70-4044, Fax (02)92 0601

For all other countries apply to: Philips Semiconductors,  
International Marketing and Sales, Building BE-p,  
P.O. Box 218, 5600 MD EINDHOVEN, The Netherlands,  
Telex 35000 phtcnl, Fax +31-40-724825  
SCD32 ©Philips Electronics N.V. 1994

All rights are reserved. Reproduction in whole or in part is prohibited  
without the prior written consent of the copyright owner.

The information presented in this document does not form part of any  
quotation or contract, is believed to be accurate and reliable and may be  
changed without notice. No liability will be accepted by the publisher for  
any consequence of its use. Publication thereof does not convey nor imply  
any license under patent- or industrial or intellectual property rights.

## Printed in the USA

4140Q/32.5M/CR4/pp1400

Date of release: June 1994

Document order number USA:

98-1900-000-04



This book was printed on recycled paper.

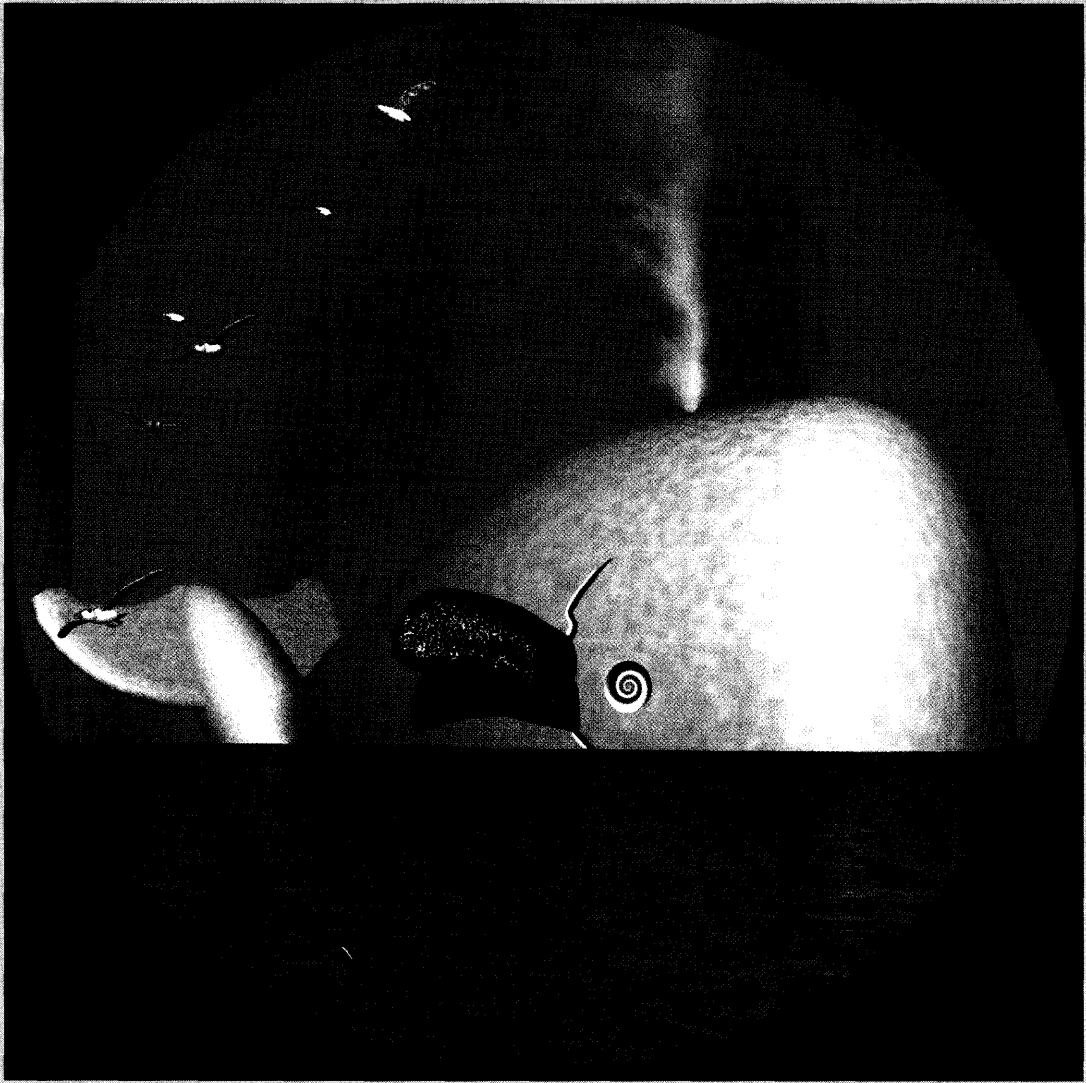

98-1900-000-04

**Philips Semiconductors**



**PHILIPS**