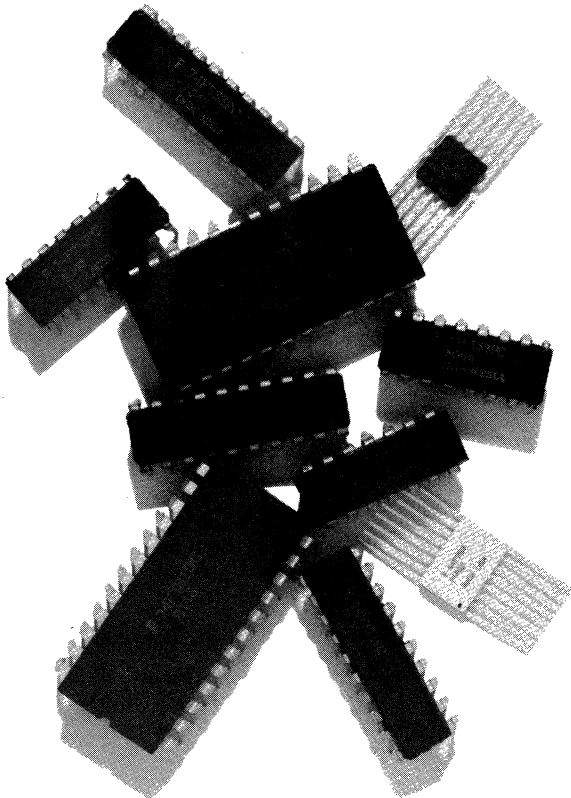




# FAST

Fairchild Advanced Schottky TTL



© 1982 Fairchild Camera and Instrument Corporation  
Digital Products Division  
333 Western Avenue • South Portland, Maine 04106  
207/775-8100 • Telex 710-221-1980

**FAIRCHILD**  
A Schlumberger Company



---

# Introduction

---

Fairchild Advanced Schottky TTL, FAST, is a family of TTL circuits that exhibits a combination of performance and efficiency unapproached by any other TTL family. Made with the proven Isoplanar process, 54F/74F circuits offer the switching speed and output drive capability of Schottky TTL, with superior noise margins and only one-fourth the power consumption.

## **Section 1 Product Index and Selection Guide**

Lists 54F/74F circuits currently available, in design or planned. The Selection Guide groups the circuits by function.

## **Section 2 Circuit Characteristics**

Discusses FAST technology, circuit configurations and characteristics.

## **Section 3 Ratings, Specifications and Waveforms**

Contains common ratings and specifications for FAST devices, as well as ac test load and waveforms.

## **Section 4 Data Sheets**

Contains data sheets for currently available and pending new products.

## **Section 5 New Products**

Contains brief descriptions of new products currently planned.

## **Section 6 Ordering Information and Package Outlines**

Explains simplified purchasing code which identifies not only device type but also the package type and temperature range. Contains detailed physical dimension drawings for each package.

## **Section 7 Field Sales Offices, Representatives and Distributor Locations**



---

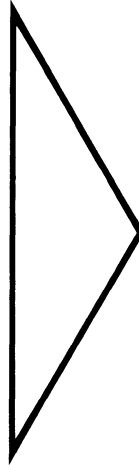
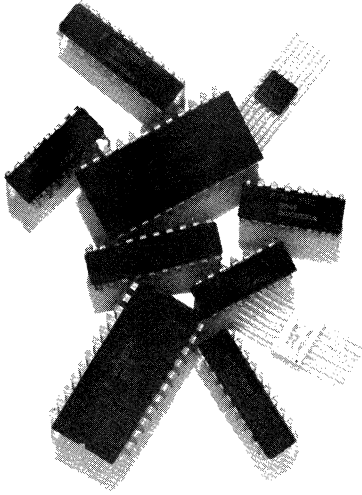
# Table of Contents

---

<b>Section 1 Product Index and Selection Guide</b>	
Product Index	1-3
Gates	1-6
Dual Edge-Triggered Flip-Flops	1-6
Multiple Flip-Flop/Registers	1-6
Latches	1-7
Multiplexers	1-7
Decoders/Demultiplexers	1-7
Shift Registers/FIFOs	1-8
Synchronous Presettable Counters	1-8
3-State Buffer/Line Driver/Transceivers	1-9
Arithmetic Operators	1-10
Memory	1-11
Memory Peripherals	1-11
Specialized LSI	1-11
<b>Section 2 Circuit Characteristics</b>	
FAST Technology	2-3
FAST Circuitry	2-4
Output Characteristics	2-6
Input Characteristics	2-8
3-State Outputs	2-10
<b>Section 3 Ratings, Specifications and Waveforms</b>	
Unit Loads (U.L.)	3-3
Absolute Maximum Ratings	3-3
Recommended Operating Conditions	3-3
54F/74F Family DC Characteristics	3-4*
AC Loading and Waveforms	3-5
<b>Section 4 Data Sheets</b>	4-3
<b>Section 5 New Products</b>	5-3
<b>Section 6 Ordering Information and Package Outlines</b>	
Ordering Information	6-3
Package Outlines	6-4
<b>Section 7 Sales Offices, Representatives and Distributor Locations</b>	
	7-3

\*Also shown on inside back cover.





<b>Product Index and Selection Guide</b>	<b>1</b>
<b>Circuit Characteristics</b>	<b>2</b>
<b>Ratings, Specifications and Waveforms</b>	<b>3</b>
<b>Data Sheets</b>	<b>4</b>
<b>New Products</b>	<b>5</b>
<b>Ordering Information and Package Outlines</b>	<b>6</b>
<b>Sales Offices, Representatives and Distributor Locations</b>	<b>7</b>





# Section 1

# Product Index and Selection Guide

## Product Index

Device No.	Description	Page No.
29F01	4-Bit Bipolar Microprocessor Slice	5-3
29F10	Microprogram Controller	5-4
29F705	16-Word by 4-Bit, 2-Port Random Access Memory	5-5
54F/74F00	Quad 2-Input NAND Gate	4-3
54F/74F02	Quad 2-Input NOR Gate	4-4
54F/74F04	Hex Inverter	4-5
54F/74F08	Quad 2-Input AND Gate	4-6
54F/74F10	Triple 3-Input NAND Gate	4-7
54F/74F11	Triple 3-Input AND Gate	4-8
54F/74F20	Dual 4-Input NAND Gate	4-9
54F/74F32	Quad 2-Input OR Gate	4-10
54F/74F64	4-2-3-2-Input AND OR-Invert Gate	4-11
54F/74F74	Dual D-Type Positive Edge-Triggered Flip-Flop	4-12
54F/74F86	Quad 2-Input Exclusive-OR Gate	4-15
54F/74F109	Dual JK Positive Edge-Triggered Flip-Flop	4-16
54F/74F112	Dual JK Negative Edge-Triggered Flip-Flop	4-19
54F/74F113	Dual JK Edge-Triggered Flip-Flop	4-22
54F/74F114	Dual JK Negative Edge-Triggered Flip-Flop	4-25
54F/74F138	1-of-8 Decoder/Demultiplexer	4-28
54F/74F139	Dual 1-of-4 Decoder	4-31
54F/74F148	8-Line to 3-Line Priority Encoder	4-34
54F/74F151	8-Input Multiplexer	4-38
54F/74F153	Dual 4-Input Multiplexer	4-41
54F/74F157	Quad 2-Input Multiplexer	4-44
54F/74F158	Quad 2-Input Multiplexer	4-47
54F/74F160	Synchronous Presettable BCD Decade Counter	4-50
54F/74F161	Synchronous Presettable Binary Counter	4-54
54F/74F162	Synchronous Presettable BCD Decade Counter	4-50
54F/74F163	Synchronous Presettable Binary Counter	4-54
54F/74F164	Serial-In Parallel-Out Shift Register	4-58
54F/74F168	4-Stage Synchronous Bidirectional Counter	4-61
54F/74F169	4-Stage Synchronous Bidirectional Counter	4-61
54F/74F174	Hex D Flip-Flop	4-65
54F/74F175	Quad D Flip-Flop	4-68
54F/74F181	4-Bit Arithmetic Logic Unit	4-71
54F/74F182	Carry Lookahead Generator	4-75
54F/74F189	64-Bit Random Access Memory	4-79
54F/74F190	Up/Down Decade Counter	4-82
54F/74F191	Up/Down Binary Counter	4-86
54F/74F192	Up/Down Decade Counter	4-91

---

**Product Index (Cont'd)**

<b>Device No.</b>	<b>Description</b>	<b>Page No.</b>
54F/74F193	Up/Down Binary Counter	4-95
54F/74F194	4-Bit Bidirectional Universal Shift Register	4-99
54F/74F211	144-Bit Random Access Memory	5-5
54F/74F212	144-Bit Random Access Memory	5-6
54F/74F213	192-Bit Random Access Memory	5-6
54F/74F219	64-Bit Random Access Memory	4-102
54F/74F240	Octal Buffer/Line Driver	4-105
54F/74F241	Octal Buffer/Line Driver	4-105
54F/74F242	Quad Bus Transceiver	4-107
54F/74F243	Quad Bus Transceiver	4-107
54F/74F244	Octal Buffer/Line Driver	4-105
54F/74F245	Octal Bidirectional Transceiver	4-110
54F/74F251	8-Input Multiplexer	4-112
54F/74F253	Dual 4-Input Multiplexer	4-115
54F/74F257	Quad 2-Input Multiplexer	4-118
54F/74F258	Quad 2-Input Multiplexer	4-121
54F/74F269	8-Bit Bidirectional Binary Counter	5-7
54F/74F280	9-Bit Parity Generator/Checker	4-124
54F/74F283	4-Bit Binary Full Adder	4-127
54F/74F289	64-Bit Random Access Memory	4-131
54F/74F299	8-Input Universal Shift/Storage Register	4-134
54F/74F311	144-Bit Random Access Memory	5-7
54F/74F312	144-Bit Random Access Memory	5-8
54F/74F313	192-Bit Random Access Memory	5-8
54F/74F319	64-Bit Random Access Memory	4-138
54F/74F322	8-Bit Serial/Parallel Register	4-141
54F/74F323	8-Bit Universal Shift/Storage Register	4-145
54F/74F350	4-Bit Shifter	4-149
54F/74F352	Dual 4-Input Multiplexer	4-153
54F/74F353	Dual 4-Input Multiplexer	4-156
54F/74F373	Octal Transparent Latch	4-159
54F/74F374	Octal D-Type Flip-Flop	4-162
54F/74F378	Parallel D Register	4-164
54F/74F379	Quad Parallel Register	4-167
54F/74F381	4-Bit Arithmetic Logic Unit	4-170
54F/74F382	4-Bit Arithmetic Logic Unit	4-175
54F/74F384	8-Bit Serial/Parallel Twos Complement Multiplier	4-180
54F/74F385	Quad Serial Adder/Subtractor	4-185
54F/74F398	Quad 2-Port Register	4-188
54F/74F399	Quad 2-Port Register	4-188
54F/74F401	Cyclic Redundancy Check Generator/Checker	5-9
54F/74F402	Expandable Cyclic Redundancy Check Generator/Checker	5-9
54F/74F403	16 X 4 First-In First-Out Buffer Memory	5-10
54F/74F412	Multi-mode Buffered Latch	5-10
54F/74F413	64 X 4 First-In First-Out Buffer Memory	5-11

---

**Product Index (Cont'd)**

<b>Device No.</b>	<b>Description</b>	<b>Page No.</b>
54F/74F416	16-Bit Memory Error Detection And Correction Circuit	5-11
54F/74F418	32-Bit Memory Error Detection And Correction Circuit	5-12
54F/74F430	Cyclic Redundancy Checker/Corrector	5-13
54F/74F432	Multi-mode Buffered Latch	5-13
54F/74F433	64 X 4 First-In First-Out Buffer Memory	5-14
54F/74F500	6-Bit Analog-to-Digital Converter	5-14
54F/74F505	8-Bit Analog-to-Digital Converter	5-15
54F/74F521	8-Bit Identity Comparator	4-192
54F/74F524	8-Bit Registered Comparator	4-195
54F/74F525	16-Stage Programmable Counter/Timer	5-15
54F/74F533	Octal Transparent Latch	4-201
54F/74F534	Octal D-Type Flip-Flop	4-203
54F/74F537	1-of-10 Decoder	4-206
54F/74F538	1-of-8 Decoder	4-209
54F/74F539	Dual 1-of-4 Decoder	4-212
54F/74F543	Octal Registered Transceiver	4-215
54F/74F544	Octal Registered Transceiver	4-215
54F/74F545	Octal Bidirectional Transceiver	4-219
54F/74F547	Octal Decoder/Demultiplexer	4-222
54F/74F548	Octal Decoder/Demultiplexer	4-226
54F/74F550	Octal Registered Transceiver	4-229
54F/74F551	Octal Registered Transceiver	4-229
54F/74F557	8-Bit By 8-Bit Multiplier	4-234
54F/74F558	8-Bit By 8-Bit Multiplier	4-234
54F/74F559	Expandable 8-Bit Twos Complement Multiplier/Divider	5-16
54F/74F568	4-Bit Bidirectional Counter	4-240
54F/74F569	4-Bit Bidirectional Counter	4-240
54F/74F579	8-Bit Bidirectional Binary Counter	5-16
54F/74F582	4-Bit BCD Arithmetic Logic Unit	5-17
54F/74F583	4-Bit BCD Adder	5-17
54F/74F588	Octal Bidirectional Transceiver	4-247
54F/74F604	Dual Octal Register	5-18
54F/74F605	Dual Octal Register	5-18
54F/74F606	Dual Octal Register	5-18
54F/74F607	Dual Octal Register	5-18
54F/74F610	Memory Mapper	5-19
54F/74F611	Memory Mapper	5-20
54F/74F612	Memory Mapper	5-21
54F/74F613	Memory Mapper	5-22
54F/74F630	16-Bit Error Detection And Correction Circuit	5-23
54F/74F631	16-Bit Error Detection And Correction Circuit	5-23
54F/74F673	16-Bit Shift Register	4-250
54F/74F674	16-Bit Shift Register	4-254
54F/74F675	16-Bit Shift Register	4-257
54F/74F676	16-Bit Shift Register	5-24
54F/74F779	8-Bit Bidirectional Binary Counter	5-25
54F/74F784	8-Bit Serial/Parallel Multiplier	5-25

## Selection Guide

### Gates

Function	Device No.	Page No.	Function	Device No.	Page No.
<i>NAND</i>			<i>OR/NOR/Exclusive-OR</i>		
Quad 2-Input	54F/74F00	4-3	Quad 2-Input OR	54F/74F32	4-10
Triple 3-Input	54F/74F10	4-7	Quad 2-Input NOR	54F/74F02	4-4
Dual 4-Input	54F/74F20	4-9	Quad 2-Input Exclusive-OR	54F/74F86	4-15
<i>AND</i>			<i>Invert/AND-OR-Invert</i>		
Quad 2-Input	54F/74F08	4-6	Hex Inverter	54F/74F04	4-5
Triple 3-Input	54F/74F11	4-8	AND-OR-Invert	54F/74F64	4-11

### Dual Edge-Triggered Flip-Flops

Function	Device No.	Inputs	Clock Edge	Direct Set	Direct Clear	Maximum Clock Frequency @25°C MHz (Min)	Page No.
Dual D	54F/74F74	D		Yes	Yes	100	4-12
Dual JK	54F/74F109	J,K		Yes	Yes	90	4-16
Dual JK	54F/74F112	J,K		Yes	Yes	100	4-19
Dual JK	54F/74F113	J,K		Yes	No	100	4-22
Dual JK	54F/74F114	J,K		Yes	Yes	100	4-25

### Multiple Flip-Flop/Registers

Function	Device No.	Data Inputs	Common Clear (Level)	CP Inputs (Level)	Maximum Clock Frequency @25°C MHz (Min)	Page No.
4-Bit D Flip-Flop	54F/74F175	4 x D	1(L)	1 (	100	4-68
4-Bit D Flip-Flop	54F/74F379	4 x D		1 (	100	4-167
6-Bit D Flip-Flop	54F/74F174	6 x D	1(L)	1 (	100 <sup>2</sup>	4-65
6-Bit D Flip-Flop	54F/74F378	6 x D		1 (	100 <sup>2</sup>	4-164
8-Bit D Flip-Flop (3S) <sup>1</sup>	54F/74F374	8 x D		1 (	100	4-162
8-Bit D Flip-Flop (3S) <sup>1</sup>	54F/74F534	8 x D		1 (	100	4-203
Dual 8-Bit Register (3S) <sup>1</sup>	54F/74F604	2(8 x D)		1 (	NA	5-18
Dual 8-Bit Register (OC) <sup>1</sup>	54F/74F605	2(8 x D)		1 (	NA	5-18
Dual 8-Bit Register (3S) <sup>1</sup>	54F/74F606	2(8 x D)		1 (	NA	5-18
Dual 8-Bit Register (OC) <sup>1</sup>	54F/74F607	2(8 x D)		1 (	NA	5-18
Quad 2-Port Register	54F/74F398	2(4 x D)		1 (	100	4-188
Quad 2-Port Register	54F/74F399	2(4 x D)		1 (	100	4-188
Octal Registered Transceiver (3S) <sup>1</sup>	54F/74F550	2(8 x D)		2 (		4-229
Octal Registered Transceiver (3S) <sup>1</sup>	54F/74F551	2(8 x D)		2 (		4-229

1. 3S = 3-state

2. Preliminary

3. NA = Data not available

**Selection Guide (Cont'd)**

**Latches**

Function	Device No.	Data Inputs	Common Clear (Level)	Enable Inputs (Level)	Enable Pulse Width @25°C ns (Min)	Enable to Output Delay @25°C ns (Max)	Page No.
Octal D (3S)*	54F/74F373	8 x D		1 (H)	6.0	11.5	4-159
Octal D (3S)*	54F/74F533	8 x D		1 (H)	6.0	11	4-201
Octal D (3S)* w/Interrupt	54F/74F412	8 x D	1 (L)				5-10
Octal D (3S)* w/Interrupt	54F/74F432	8 x D	1 (L)				5-13
Octal D Registered Transceiver (3S)*	54F/74F543	2(8 x D)		2 (L)		12**	4-215
Octal D Registered Transceiver (3S)*	54F/74F544	2(8 x D)		2 (L)		12**	4-215

**Multiplexers**

Function	Device No.	Enable Inputs (Level)	True Output	Complement Output	Page No.
4-Input (3S)*	54F/74F350	1 (L)	Yes	No	4-149
8-Input	54F/74F151	1 (L)	Yes	Yes	4-38
8-Input (3S)	54F/74F251	1 (L)	Yes	Yes	4-112
Dual 4-Input	54F/74F153	2 (L)	Yes	No	4-41
Dual 4-Input (3S)*	54F/74F253	2 (L)	Yes	No	4-115
Dual 4-Input	54F/74F352	2 (L)	No	Yes	4-153
Dual 4-Input (3S)*	54F/74F353	2 (L)	No	Yes	4-156
Quad 2-Input	54F/74F157	1 (L)	Yes	No	4-44
Quad 2-Input	54F/74F158	1 (L)	No	Yes	4-47
Quad 2-Input (3S)*	54F/74F257	1 (L)	Yes	No	4-118
Quad 2-Input (3S)*	54F/74F258	1 (L)	No	Yes	4-121
Quad 2-Input	54F/74F398		Yes	Yes	4-188
Quad 2-Input	54F/74F399		Yes	No	4-188

**Decoders/Demultiplexers**

Function	Device No.	Address Inputs	Active-LOW Enable	Active-HIGH Enable	Active-LOW Output Enable	Active-LOW Outputs	Active-HIGH Outputs	Page No.
Dual 1-of-4	54F/74F139	2 + 2	1 + 1			4 + 4		4-31
Dual 1-of-4 (3S)*	54F/74F539	2 + 2	1 + 1		1 + 1		4 + 4	4-212
1-of-8	54F/74F138	3	2	1		8		4-28
1-of-8 (3S)*	54F/74F538	3	2	2	2		8	4-209
1-of-8 w/Address Latches	54F/74F547	3	1	2		8		4-222
1-of-8	54F/74F548	3	2	2		8		4-226
1-of-10 (3S)*	54F/74F537	4	1	1	1		10	4-206

\*3S = 3-State; OC = Open-collector

\*\* Preliminary

## Selection Guide (Cont'd)

### Shift Registers/FIFOs

Function	Device No.	No. of Bits	Serial Entry	Clock Edge	Maximum Clock Frequency @25°C MHz (Min)	Page No.
Shift Right, Serial-in/Parallel-out	54F/74F164	8	2		80	4-58
Shift Right, Serial/Parallel-in, Parallel/Serial-out (3S) <sup>1</sup>	54F/74F322	8	2		70 <sup>3</sup>	4-141
Shift Right, Serial-in, Serial/Parallel-out	54F/74F673	16	1		100 <sup>3</sup>	4-250
Shift Right, Serial/Parallel-in, Serial-out	54F/74F674	16	1		100 <sup>3</sup>	4-254
Shift Right, Serial-in, Serial/Parallel-out	54F/74F675	16	1		100 <sup>3</sup>	4-257
Shift Right, Serial/Parallel-in, Serial-out	54F/74F676	16	1		100 <sup>3</sup>	5-24
Bidirectional, Serial/Parallel-in, Parallel/Serial-out	54F/74F194	4	2		105	4-99
Bidirectional, Serial/Parallel-in, Parallel/Serial-out (3S) <sup>1</sup>	54F/74F299	8	2		70 <sup>3</sup>	4-134
Bidirectional, Serial/Parallel-in, Parallel/Serial-out (3S) <sup>1</sup>	54F/74F323	8	2		70 <sup>3</sup>	4-145
16 x 4 FIFO, Serial/Parallel-in, Serial/Parallel-out (3S) <sup>1</sup>	54F/74F403	4	1			5-10
64 x 4 FIFO, Parallel-in/Parallel-out	54F/74F413	4				5-11
64 x 4 FIFO, Serial/Parallel-in, Serial/Parallel-out (3S) <sup>1</sup>	54F/74F433	4	1			5-14

### Synchronous Presettable Counters

Function	Device No.	Modulus	No. of Bits	Parallel Entry <sup>2</sup>	Maximum Clock Frequency @25°C MHz (Min)	Page No.
BCD Count-Up	54F/74F160	10	4	S	100 <sup>3</sup>	4-50
BCD Count-Up	54F/74F162	10	4	S	100 <sup>3</sup>	4-50
BCD Up-Down	54F/74F168	10	4	S	75 <sup>3</sup>	4-61
BCD Up-Down	54F/74F190	10	4	A	80	4-82
BCD Up-Down	54F/74F192	10	4	A	80 <sup>3</sup>	4-91
BCD Up-Down (3S) <sup>1</sup>	54F/74F568	10	4	S	75 <sup>3</sup>	4-240
Binary Count-Up	54F/74F161	16	4	S	100 <sup>3</sup>	4-54
Binary Count-Up	54F/74F163	16	4	S	100 <sup>3</sup>	4-54
Binary Up-Down	54F/74F169	16	4	S	75 <sup>3</sup>	4-61
Binary Up-Down	54F/74F191	16	4	A	80	4-86
Binary Up-Down	54F/74F193	16	4	A	80	4-95
Binary Up-Down (3S) <sup>1</sup>	54F/74F569	16	4	S	75 <sup>3</sup>	4-240
Binary Up-Down	54F/74F269	256	8	S	100 <sup>3</sup>	5-7
Binary Up-Down (3S) <sup>1</sup>	54F/74F579	256	8	S	100 <sup>3</sup>	5-16
Binary Up-Down (3S) <sup>1</sup>	54F/74F779	256	8	S	100 <sup>3</sup>	5-25

1. (3S) = 3-state

2. S = Synchronous; A = Asynchronous

3. Preliminary

---

**Selection Guide (Cont'd)****3-State Buffer/Line Driver/Transceivers**

<b>Function</b>	<b>Device No.</b>	<b>Enable Inputs (Level)</b>	<b>Current Sinking Side A/Side B mA</b>	<b>Page No.</b>
Octal Buffer/Line Driver	54F/74F240	2(L)	64	4-105
Octal Buffer/Line Driver	54F/74F241	1(L) + 1(H)	64	4-105
Octal Buffer/Line Driver	54F/74F244	2(L)	64	4-105
Quad Bus Transceiver	54F/74F242	1(L) + 1(H)	64/64	4-107
Quad Bus Transceiver	54F/74F243	1(L) + 1(H)	64/64	4-107
Octal Bus Transceiver	54F/74F245	1(L)	20/64	4-110
Octal Bus Transceiver	54F/74F545	1(L)	20/64	4-219
Octal Registered Transceiver	54F/74F543	2(L)	20/64	4-215
Octal Registered Transceiver	54F/74F544	2(L)	20/64	4-215
Octal Registered Transceiver	54F/74F550	2(L)	20/64	4-229
Octal Registered Transceiver	54F/74F551	2(L)	20/64	4-229
GPIO Octal Transceiver	54F/74F588	1(L)	20/64	4-247



**Selection Guide (Cont'd)**

**Arithmetic Operators**

Function	Device No.	Description	No. of Bits	Page No.
Adder	54F/74F283	Full Binary 4-Bit with Fast Carry	4	4-127
Adder	54F/74F583	Full BCD with Fast Carry	4	5-17
Adder/Subtractor	54F/74F385	Quad Serial with Carry-Save	4 x 1	4-185
Adder/Subtractor	54F/74F582	BCD Add/Subtract/Compare with Ripple and Lookahead Carry	4	5-17
Arithmetic Logic Unit	29F01	4-Bit Slice ALU with 2-Port RAM	4	5-3
Arithmetic Logic Unit	54F/74F181	ALU with Ripple and Lookahead Carry	4	4-71
Arithmetic Logic Unit	54F/74F381	ALU with Lookahead Carry	4	4-170
Arithmetic Logic Unit	54F/74F382	ALU with Ripple Carry and Overflow	4	4-175
Carry Lookahead	54F/74F182	CLA for 4 ALUs		4-75
Comparator	54F/74F521	8-Bit Equality Comparator	2 x 8	4-192
Comparator	54F/74F524	8-Bit Registered Full Comparator	2 x 8	4-195
Controller	29F10	Microprogram Controller with Counters and Stack	12	5-4
Encoder	54F/74F148	8-Bit Priority Encoder	8	4-34
Error Detect	54F/74F401	16-Bit CRC Generator/Checker	16	5-9
Error Detect	54F/74F402	Expandable 16-Bit CRC Generator/Checker	16	5-9
Error Detect/Correct	54F/74F630	16-Bit Parallel Data Error Detect/Correct/ Syndrome Generator (3S)*	16	5-23
Error Detect/Correct	54F/74F631	16-Bit Parallel Data Error Detect/Correct/ Syndrome Generator(OC)*	16	5-23
Error Detect/Correct	54F/74F416	16-Bit Parallel Data Error Detect/Correct(3S)*	16	5-11
Error Detect/Correct	54F/74F418	32-Bit Parallel Data Error Detect/Correct (3S)*	32	5-12
Error Detect/Correct	54F/74F430	Serial Burst Error Detect/Correct	32	5-13
Multiplier	54F/74F384	8-Bit Serial/Parallel Sequential	1 x 8	4-180
Multiplier	54F/74F784	8-Bit Serial/Parallel Sequential with Adder/Subtractor	1 x 8	5-25
Multiplier	54F/74F557	8 x 8 Bit Parallel with Latches (3S)*	8 x 8	4-234
Multiplier	54F/74F558	8 x 8 Bit Parallel (3S)*	8 x 8	4-234
Multiplier/Divider	54F/74F559	8 x 8 Bit Expandable	8 x 8	5-16
Parity	54F/74F280	9-Bit Parity Generator/Checker	9	4-124
Shifter	54F/74F350	Expandable 4-Bit Shifter	4	4-149

\*3S = 3-State; OC = Open-collector

**Selection Guide (Cont'd)**

**Memory**

<b>Organization</b>	<b>Device No.</b>	<b>Address Access Time ns (Max) MII/Com</b>	<b>Chip Select Access Time ns (Max) MII/Com</b>	<b>Page No.</b>
16 x 4 RAM (3S)*	54F/74F189	22/18	14/11.5	4-79
16 x 4 RAM (3S)*	54F/74F219	18/18	11.5/14	4-102
16 x 4 RAM (OC)*	54F/74F289	18**	8.0**	4-131
16 x 4 RAM (OC)*	54F/74F319	18**	8.0**	4-138
16 x 4 RAM (3S)*	29F705	30**		5-5
16 x 9 RAM (3S)*	54F/74F212	15**	8.0**	5-6
16 x 9 RAM w/Latch (3S)*	54F/74F211	15**	8.0**	5-5
16 x 9 RAM (OC)*	54F/74F312	15**	8.0**	5-8
16 x 9 RAM w/Latch (OC)*	54F/74F311	15**	8.0**	5-7
16 x 12 RAM (3S)*	54F/74F213	15**	8.0**	5-6
16 x 12 RAM (OC)*	54F/74F313	15**	8.0**	5-8

**Memory Peripherals**

<b>Description</b>	<b>Device No.</b>	<b>Page No.</b>
Memory Mapper (3S)*	54F/74F612	5-12
Memory Mapper w/Latched Outputs (3S)*	54F/74F610	5-19
Memory Mapper (OC)*	54F/74F613	5-22
Memory Mapper w/Latched Outputs (OC)*	54F/74F611	5-20
16-Bit Error Detection/Correction (3S)*	54F/74F630	5-23
16-Bit Error Detection/Correction (OC)*	54F/74F631	5-23
32-Bit Error Detection/Correction	54F/74F418	5-12
Serial Burst Error Detecton/Correction	54F/74F430	5-13

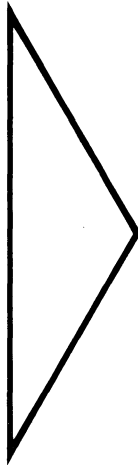
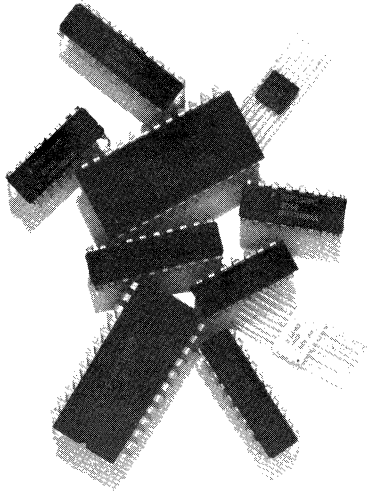
**Specialized LSI**

<b>Description</b>	<b>Device No.</b>	<b>Page No.</b>
Cyclical Redundancy Check (CRC) Generator/Checker	54F/74F401	5-9
Expandable Cyclical Redundancy Check (CRC) Generator/Checker	54F/74F402	5-9
Serial Burst Error Detection/Correction	54F/74F430	5-13
6-Bit A/D Flash Converter	54F/74F500	5-14
8-Bit A/D Converter (Successive Approximation)	54F/74F505	5-15
16-Stage Programmable Counter/Divider	54F/74F525	5-15
4-Bit Microprocessor Slice	29F01	5-3
Microprogram Controller	29F10	5-4

\*3S = 3-State; OC = Open-collector

\*\* Preliminary





<b>Product Index and Selection Guide</b>	<b>1</b>
<b>Circuit Characteristics</b>	<b>2</b>
<b>Ratings, Specifications and Waveforms</b>	<b>3</b>
<b>Data Sheets</b>	<b>4</b>
<b>New Products</b>	<b>5</b>
<b>Ordering Information and Package Outlines</b>	<b>6</b>
<b>Sales Offices, Representatives and Distributor Locations</b>	<b>7</b>



### FAST Technology

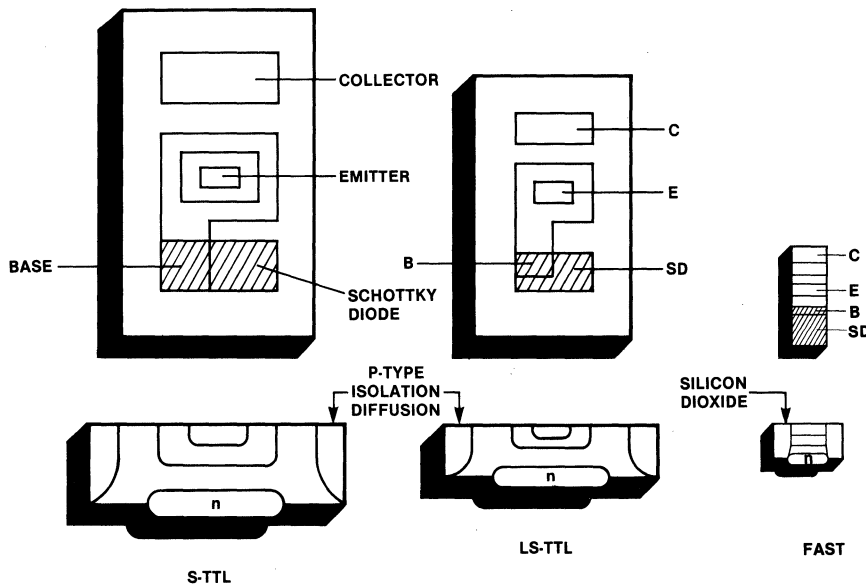
FAST is an acronym for Fairchild Advanced Schottky TTL. FAST circuits are made with the advanced Isoplanar II process, which produces transistors with very high, well-controlled switching speeds, extremely small parasitic capacitances and  $f_T$  in excess of 5 GHz. Isoplanar is an established Fairchild process, used for years in the manufacture of bipolar memories, CMOS, subnanosecond ECL and I<sup>3</sup>L™ (Isoplanar Integrated Injection Logic) LSI devices.

In the Isoplanar process, components are isolated by a selectively grown thick oxide rather than the P<sup>+</sup> isolation region used in the Planar process. Since this oxide needs no separation from the base-collector regions, component and chip sizes are substantially reduced. The base and emitter ends terminate in the oxide wall; masks can thus overlap the device area into the isolation oxide. This overlap feature eliminates the extremely close tolerances normally required for base and emitter masking, and the standard photolithographic processes can be used.

Figure 2-1 shows the relative size of phase-splitter transistors (Q2 in Figure 2-3) used in Schottky, Low Power Schottky and FAST circuits. The LS-TTL transistor is smaller than that of S-TTL because of process refinements, shallower diffusions and smaller operating currents. The relative size of the FAST transistor illustrates the remarkable reduction afforded by the Isoplanar process. This in turn reduces junction capacitances, while the oxide isolation reduces side-wall capacitance. The effect of these reductions is an increase in frequency response by a factor of three or more. Figure 2-2 shows the frequency response of two sizes of transistors made with the Isoplanar II process. Because they have modest, well-defined loads and thus can use smaller, faster transistors, internal gates of MSI devices are faster than SSI gates such as the 74F00 or 74F02. SSI gates, on the other hand, are designed to have high output drive capability and thus use larger transistors.

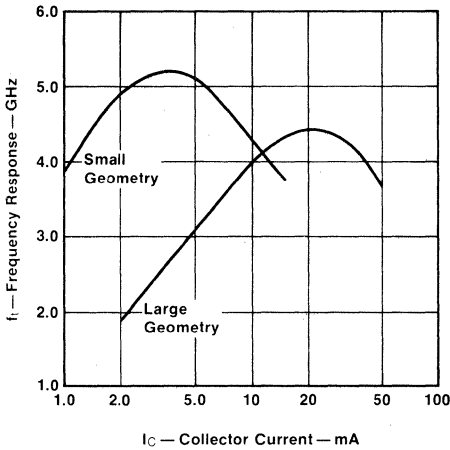
As is the case with other modern LSI processes, the shallower diffusions and thinner oxides make FAST

Fig. 2-1 Relative Transistor Sizes in Various TTL Families



devices more susceptible to damage from electrostatic discharge than are devices of earlier TTL families. Users should take the usual precautions when handling FAST devices: avoid placing them on non-conductive plastic surfaces or in plastic bags, make sure test equipment and jigs are grounded, individuals should be grounded before handling the devices, etc.

**Fig. 2-2 Isoplanar Transistor Frequency Response**

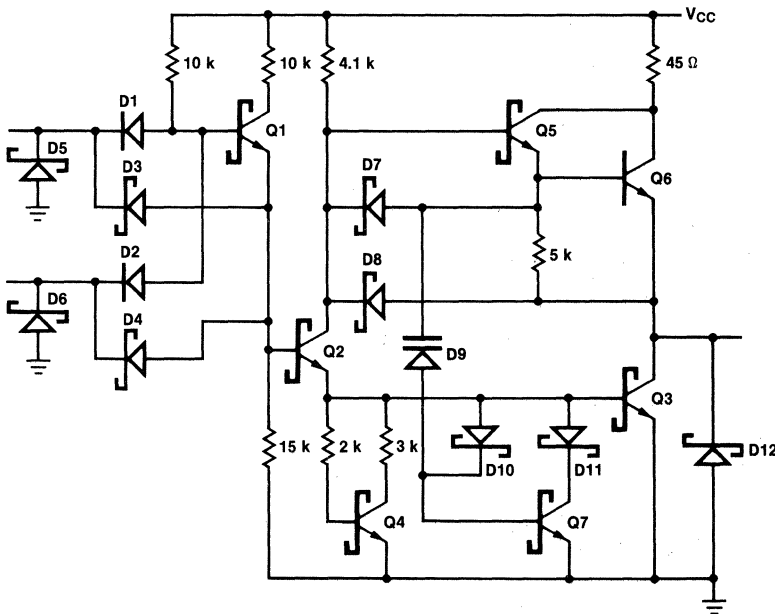


**FAST Circuitry**

The 2-input NAND gate, shown in *Figure 2-3*, has three stages of gain (Q1, Q2, Q3) instead of two stages as in other TTL families. This raises the input threshold voltage and increases the output drive. The higher threshold makes it possible to use pn diodes for the input AND function (D1 and D2) and still achieve an input threshold of 1.5 V. The capacitance of these diodes is comparatively low, which results in improved ac noise immunity. The effect of the threshold adjustment can be seen in the voltage transfer characteristics of *Figure 2-4*, *2-5* and *2-6*. At 25°C (*Figure 2-5*) the FAST circuit threshold is nearly centered between the 0.8 V and 2.0 V limits specified for TTL circuits. This gives a better balance between the HIGH- and LOW-state noise margins. The +125°C characteristics (*Figure 2-6*) show that the FAST circuit threshold is comfortably above the 0.8 V specification, more so than in S-TTL or LS-TTL circuits. At -55°C, the FAST circuit threshold is still well below the 2.0 V specification, as shown in *Figure 2-4*.

FAST circuits contain several speed-up diodes to help discharge internal capacitances. Referring again to *Figure 2-3*, when a HIGH-to-LOW transition occurs at the D1 input, for example, Schottky diode D3 acts as a low-resistance path to discharge the several parasitic capacitances connected to the base of Q2. This effect

**Fig. 2-3 Basic FAST Gate Schematic**



only comes into play, however, as the input signal falls below about 1.2 V; D3 does not act as an entry path for negative spikes superimposed on a HIGH input level. When Q2 turns on and its collector voltage falls, D7 provides a discharge path for capacitance at the base of Q6. Whereas D3, D4 and D7 enhance switching speed by helping to discharge internal nodes, D8 contributes to the ability of a FAST circuit to rapidly discharge load capacitance. Part of the charge stored in load capacitance passes through D8 and Q2 to increase the base current of Q3 and increase Q3's current sinking capability during the HIGH-to-LOW output voltage transition.

In addition to the 2K-Q4-3K squaring network, which is standard for Schottky-clamped TTL circuits, FAST circuits contain a network D9-D10-D11-Q7 whose purpose is to provide a momentary low impedance at the base of Q3 during an output LOW-to-HIGH transition. The rising voltage at the emitter of Q5 causes displacement current to flow through varactor diode D9 and momentarily turn on Q7, which in turn pulls down the base of Q3 and absorbs the displacement current that flows through the collector-base capacitance (not shown) of Q3 when the output voltage rises. Without the D9-Q7 network, the displacement current through the collector-base capacitance acts as base current, tending to prolong the turn-off of Q3 and allow current to flow from Q6 to ground through Q3.

The collector-base capacitance of Q3, although small, is effectively multiplied by the voltage gain of Q3. This phenomenon, first identified many years ago with vacuum tube triodes, is called the Miller effect. Thus the D9-Q7 network (patent applied for) is familiarly

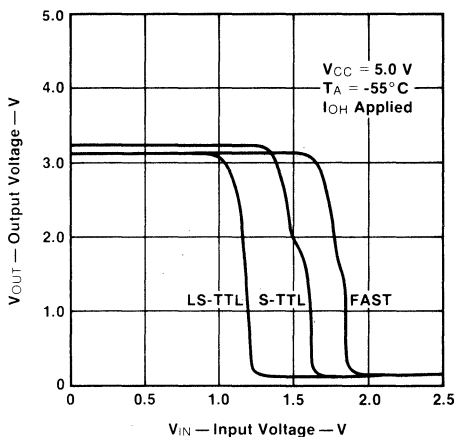
called the "Miller killer" circuit and its use improves the output rise time and minimizes power consumption during repetitive switching at high frequencies. Diode D10 completes the discharge path for D9 through D7 when Q2 turns on. D11 limits how low Q7 pulls down the base of Q3 to a level adequate for the intended purpose, without sacrificing turn-on speed when a circuit is cycled rapidly.

Also shown in *Figure 2-3* is a clamp diode D12 at the output. This diode limits negative voltage excursions due to parasitic coupling in signal lines or transmission line effects.

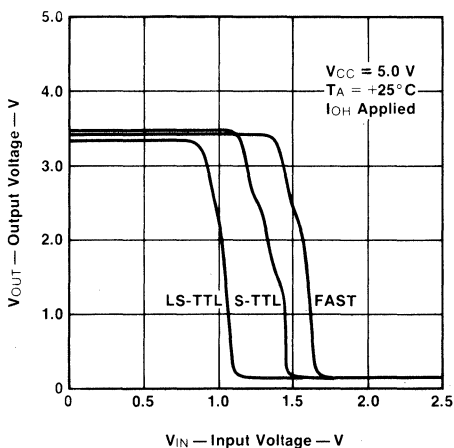
The Schottky clamping diodes built into the transistors prevent saturation, thereby eliminating storage time as a factor in switching speed. Similarly, the speed-up diodes tend to minimize the impact of other variables on switching speed. The overall effect is to minimize variation in switching speed of FAST circuits with variations in supply voltage and ambient temperature (*Figures 2-7* and *2-8*). Propagation delay is specified not only under nominal supply voltage and temperature conditions, but also over the recommended operating range of  $V_{CC}$  and  $T_A$  for both military and commercial grade devices.

The internal switching speed of a logic circuit is only one aspect of the circuit's suitability for high-speed operation at the system or subsystem level; the other aspect is the ability of the circuit to drive load capacitance. FAST circuit outputs are structured to sink at least 20 mA in the LOW state, the same as S-TTL. This capability plus the effect of the aforementioned feedback through D8 assures that the circuit can rapidly discharge capacitance. During a

**Fig. 2-4 Transfer Functions at Low Temperature**



**Fig. 2-5 Transfer Functions at Room Temperature**





LOW-to-HIGH transition, the pull-up current is limited by the  $45\ \Omega$  resistor, versus  $55\ \Omega$  for S-TTL. Therefore, FAST circuits are inherently more capable than S-TTL of charging load capacitance.

Figure 2-9 shows the effects of load capacitance on propagation delays of FAST, S-TTL and LS-TTL NAND gates. The curves show that FAST gates are not only faster than those of earlier families, but also are less affected by capacitance and exhibit less skew between the LOW-to-HIGH and HIGH-to-LOW delays. These improved characteristics offered by FAST circuits make it easier to predict system performance early in the design phase, before loading details are precisely known. The curves show that the skew between HIGH-to-LOW and LOW-to-HIGH delays for

the FAST gate is only about 0.5 ns, over a broad range of load capacitance, whereas the skew for the S-TTL gate is 1 ns or greater, depending on loading.

### Output Characteristics

Figure 2-10 shows the current-voltage characteristics of a FAST gate with the pull-down transistor Q3 turned on. These curves illustrate instantaneous conditions in discharging load capacitance during an output HIGH-to-LOW transition. When the output voltage is at about 3.5 V, for example, the circuit can absorb charge from the load capacitance at a 500 mA rate at  $+25^\circ\text{C}$ . From this level the rate decreases steadily down to about 100 mA at 1.5 V. In this region from 3.5 V to 1.5 V, part of the charge from the load capacitance is fed back through D8 (Figure 2-3) and Q2 to provide extra base

Fig. 2-6 Transfer Functions at High Temperature

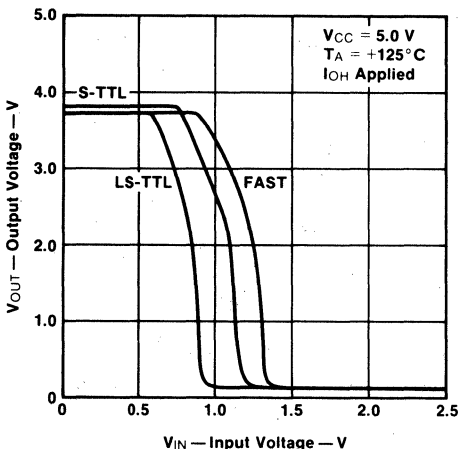


Fig. 2-8 Propagation Delay vs Temperature

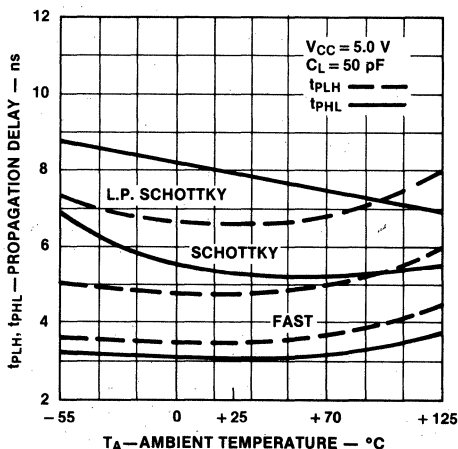


Fig. 2-7 Propagation Delay vs  $V_{CC}$

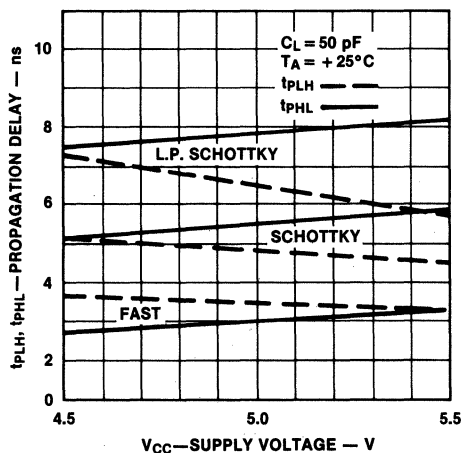
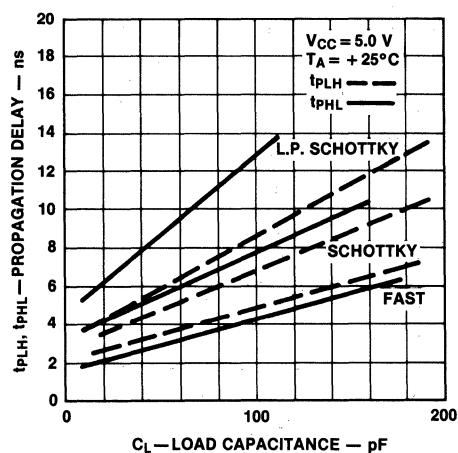


Fig. 2-9 Propagation Delay vs Load Capacitance



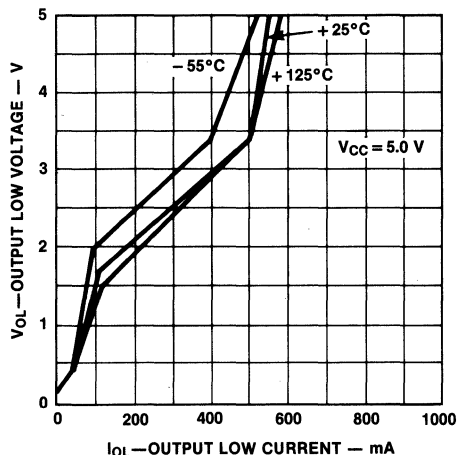
current for Q3, boosting its current-sinking capability and thus reducing the fall time. Below the 1.5 V level, Q3 continues to discharge the load capacitance, but without extra base current from DB. At about 0.5 V the integral Schottky clamp diode from base to collector of Q3 starts conducting and prevents Q3 from going into deep saturation.

On a greatly expanded scale, the output LOW characteristics of a gate are shown in *Figure 2-11*. With no load, the output voltage is about 0.1 V, increasing with current on a slope of about 7.5  $\Omega$ . When the load current increases beyond the current-sinking capability of Q3, the output voltage rises steeply. It can be seen that the worst-case specification of 0.5 V max at 20 mA load is easily met. Similar charac-

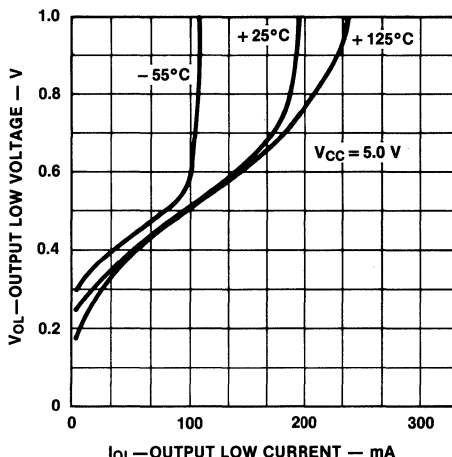
teristics for a buffer are shown in *Figure 2-12*, over a broader current range. The curves are well below the output LOW voltage specification of 0.55 V max at 48 mA over the Military temperature range or 64 mA over the Commercial temperature range.

The output HIGH characteristics of a FAST gate are shown in *Figure 2-13*. At low values of output current the voltage is approximately 3.5 V. This value is just the supply voltage minus the combined base-emitter voltages of the Darlington pull-up transistors Q5 and Q6 (*Figure 2-3*). For load currents above 16 or 18 mA, the voltage drop across the 45  $\Omega$  Darlington collector resistor becomes appreciable and the Darlington saturates. For greater load currents the output voltage decreases with a slope of about 50  $\Omega$ , which is largely

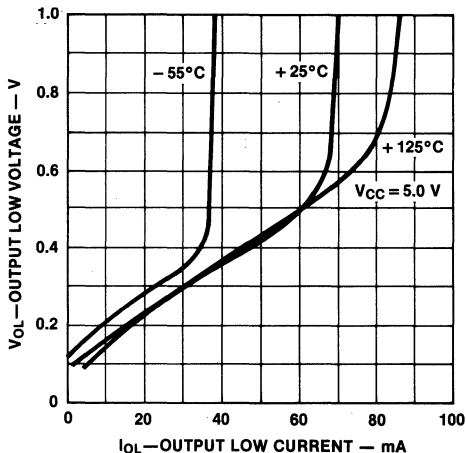
**Fig. 2-10 Output LOW Characteristics — 'F00**



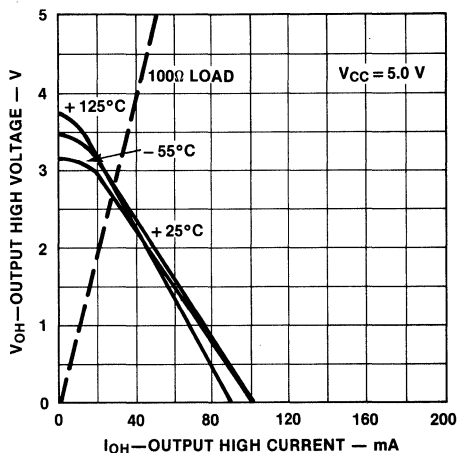
**Fig. 2-12 Output LOW Characteristics — 'F244**



**Fig. 2-11 Output LOW Characteristics — 'F00**



**Fig. 2-13 Output HIGH Characteristics — 'F00**



due to the  $45\ \Omega$  resistor. The value of current where a characteristic intersects the horizontal axis is the short-circuit output current  $I_{OS}$ . This is guaranteed to be at least 60 mA for a FAST gate, compared to 40 mA for S-TTL. This parameter is an important indicator of the ability of an output to charge load capacitance. Thus the FAST specifications insure that an output can charge load capacitance faster, or force a higher LOW-to-HIGH voltage step into the dynamic impedance of a long interconnection.

The output HIGH characteristics of a buffer are shown in Figure 2-14. These are similar in shape to Figure 2-13 but at higher levels of current. The output HIGH voltage of a buffer is guaranteed at two different levels of load current. With a 3 mA load,  $V_{OH}$  is guaranteed to be at least 2.4 V for both Military and Commercial devices.  $V_{OH}$  is also guaranteed to be at least 2.0 V with a 12 mA load for Military or 15 mA load for Commercial devices. In addition, the short-circuit output current of a buffer is guaranteed to be at least 100 mA.

When an output is driving a long interconnection, the initial LOW-to-HIGH transition is somewhat less than the final, quiescent HIGH level because of the loading effect of the line impedance. The full HIGH voltage level is only reached after the reflection from the far end of the line returns to the driver. The initial LOW-to-HIGH voltage step that an output can force into a line is determined by drawing a load line on the graph containing the output HIGH characteristic and noting the voltage value where the load line intersects the characteristic. For example, if a FAST gate is driving a

$100\ \Omega$  line, a straight line from the lower left origin up to the point 5 V, 50 mA intersects the characteristic curve at about 2.8 V. This indicates that the gate output voltage will rise to 2.8 V initially, and the 2.8 V signal, accompanied by 28 mA of current, will travel to the end of the line. If not terminated, the 28 mA is forced to return to the driver, whereupon it unloads the driver and the output voltage rises to the maximum value. Similarly, a  $50\ \Omega$  load line drawn on the buffer characteristic shows an intercept voltage of 2.5 V. In both cases, the initial voltage step is great enough to pass through the switching region of any inputs that might be located near the driver end of the line, and thus would not exhibit any exaggerated propagation delay due to the loading effect of the line impedance on the driver output. Thus the FAST output characteristics insure better system performance under adverse loading conditions.

### Input Characteristics

The input of a FAST circuit represents a small capacitance, typically 4 to 5 pF, in parallel with an I-V characteristic that exhibits different slopes over different ranges of input voltage. Figure 2-15 shows the input characteristic of a FAST gate at three temperatures. In the upper right, the flat horizontal portion is the  $V_{IH} - I_{IH}$  characteristic. In this region, all of the current from the 10K input resistor (Figure 2-3) is flowing into the base of Q1 and the only current flowing in the input diode is the leakage current  $I_{IH}$ . When the input voltage decreases to about 1.7 V (+25°C), current starts to flow out of the input diode and the curve shows a knee. At this point some of the current from the 10K resistor is diverted from the base of Q1. When

Fig. 2-14 Output HIGH Characteristics — 'F244

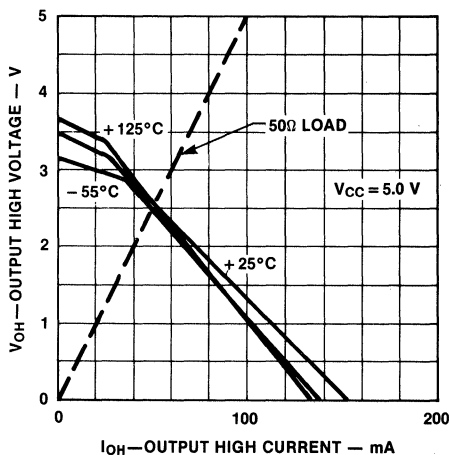
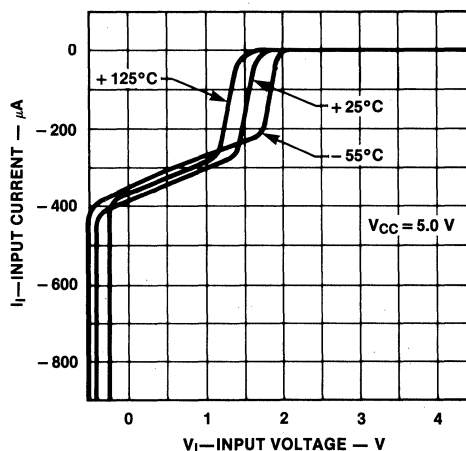


Fig. 2-15 Input Characteristics — 'F00



the input voltage declines to about 1.4 V the curve shows another knee; at this point, substantially all of the current from the 10K resistor flows out of the input diode. The portion of the curve between 1.4 V and 1.7 V input voltage is the active region, essentially corresponding to the FAST transfer function in *Figure 2-5*.

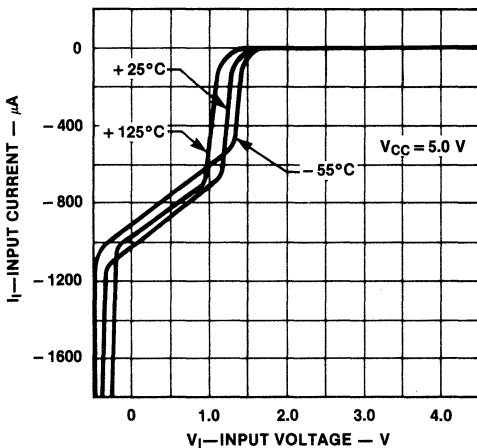
Below 1.4 V input, the characteristic has the slope of the 10K input resistor. When the input voltage declines to about -0.3 V, the Schottky clamping diode starts conducting and the current increases rapidly as the input voltage decreases further.

The input characteristics of a buffer, shown in *Figure 2-16*, differ from those of a gate in two respects. One is the location of the transition region along the horizontal axis. A buffer input has a hysteresis characteristic about 400 mV wide, such that the transition region shifts left or right accordingly as the input voltage transition is HIGH-to-LOW or LOW-to-HIGH, respectively. The curves in *Figure 2-16* apply to the HIGH-to-LOW input voltage transition. The other difference between buffer and gate characteristics is the slope of the curves below the transition region. The input resistor of a buffer is 4 K $\Omega$ , and the slope of the characteristic follows this value, rather than the 10 K $\Omega$  slope of a gate input.

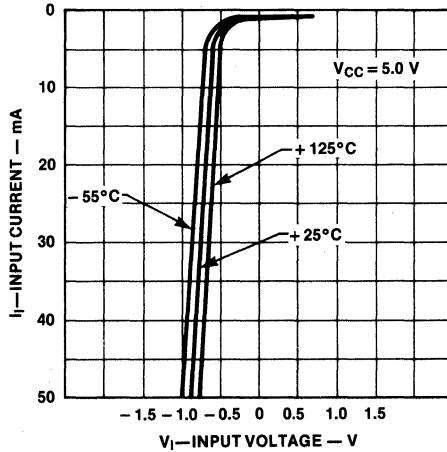
The characteristics of an input Schottky clamp diode are shown in *Figure 2-17*, for much larger values of current than those of *Figures 2-15* and *2-16*. The purpose of the clamp diode is to limit undershoot at

the end of a line following a HIGH-to-LOW signal transition. For example, an output signal change from +3.5 V to +0.5 V into a 100  $\Omega$  line propagates to the end of the line, accompanied by a 30 mA current change. If the line is terminated in a high impedance the 3 V signal change doubles, driving the terminal voltage down to -2.5 V. With the clamp diode, however, the negative excursion would be limited to about -0.7 V. The same HIGH-to-LOW signal change on a 50  $\Omega$  line would be clamped at about -1.0 V. *Figure 2-18* shows the typical breakdown characteristics for a FAST input.

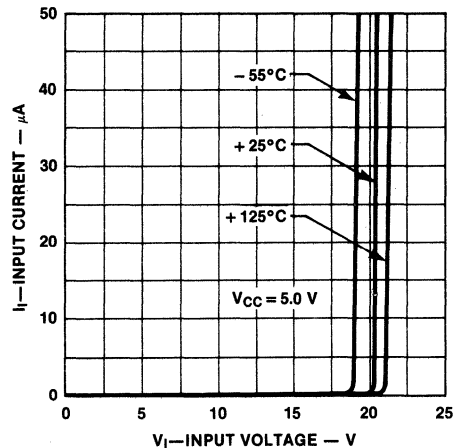
**Fig. 2-16 Input Characteristics — 'F244**



**Fig. 2-17 Input Characteristics — 'F00 or 'F244**



**Fig. 2-18 Input Characteristics — 'F00 or 'F244**

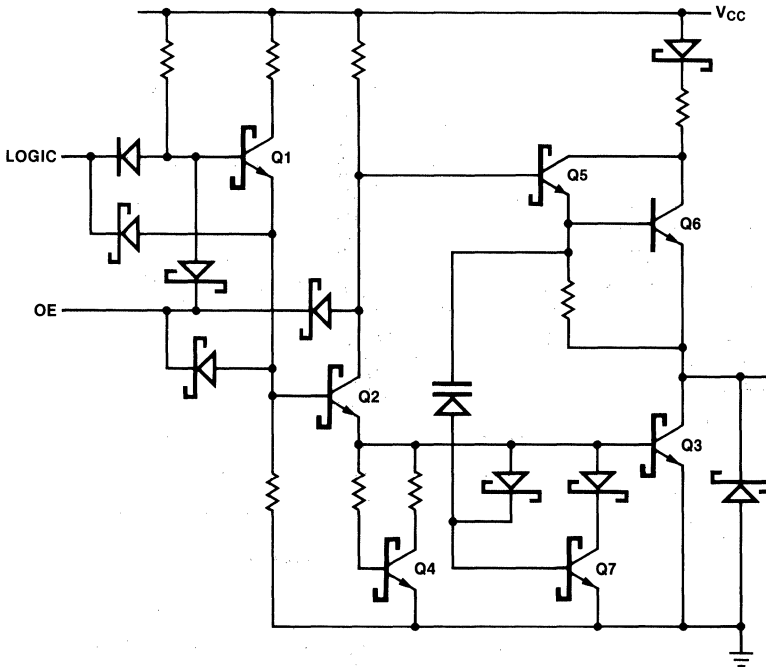


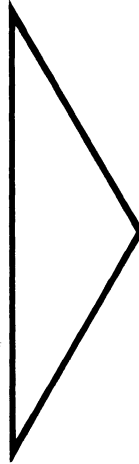
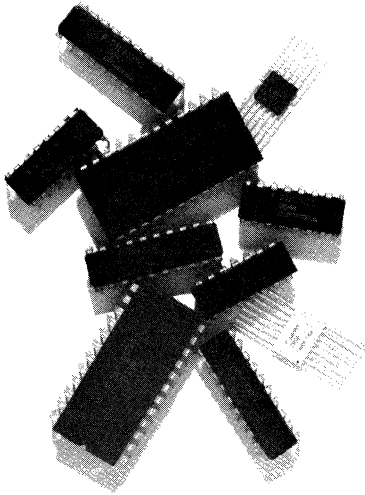
### 3-State Outputs

A partial schematic of a circuit having a 3-state output is shown in *Figure 2-19*. When the internal Output Enable (OE) signal is HIGH, the circuit operates in the normal fashion to provide HIGH or LOW output drive characteristics. When OE is LOW, however, the bases of Q1, Q2 and Q5 are pulled down. In this condition

the output is a high impedance. In this high-Z condition the output leakage is guaranteed not to exceed  $50 \mu\text{A}$ . In the case of a transceiver, each data pin is an input as well as an output and the leakage specification is increased to  $70 \mu\text{A}$ . In the high-Z state, output capacitance averages about 5 pF for a 20 mA output and about 12 pF for a 64 mA output.

**Fig. 2-19 Typical 3-State Output Control**





<b>Product Index and Selection Guide</b>	<b>1</b>
<b>Circuit Characteristics</b>	<b>2</b>
<b>Ratings, Specifications and Waveforms</b>	<b>3</b>
<b>Data Sheets</b>	<b>4</b>
<b>New Products</b>	<b>5</b>
<b>Ordering Information and Package Outlines</b>	<b>6</b>
<b>Sales Offices, Representatives and Distributor Locations</b>	<b>7</b>



### Unit Loads (U.L.)

For convenience in system design, the input loading and fan-out characteristics of each circuit are specified in terms of unit loads. One unit load in the HIGH state is defined as 40  $\mu$ A; thus both the input HIGH leakage current  $I_{IH}$  and the output HIGH current-sourcing capability  $I_{OH}$  are normalized to 40  $\mu$ A. The specified maximum  $I_{IH}$  for a standard FAST input is 20  $\mu$ A, or 0.5 U.L., while the  $I_{OH}$  rating for a standard output is 1.0 mA, or 25 U.L. Similarly, one unit load in the LOW state is defined as 1.6 mA and both the input LOW current  $I_{IL}$  and the output LOW current-sinking capability  $I_{OL}$  are normalized to 1.6 mA. The specified maximum  $I_{IL}$  for a standard FAST input is 0.6 mA, or 0.375 U.L., while the  $I_{OL}$  rating for a standard output is 20 mA, or 12.5 U.L. On

the data sheets, the input and output load factors are listed in the Input Loading/Fan-Out table. The table from the 54F/74F04 Hex Inverter is reproduced below.

In the right-hand column the input HIGH/LOW load factors are 0.5/0.375, with the first number representing  $I_{IH}$  and the second representing  $I_{IL}$ . For testing or procurement purposes, these load factors can easily be translated to actual test limits by multiplying them by 40  $\mu$ A and 1.6 mA, respectively. The second set of numbers represents the rated output HIGH/LOW load currents  $I_{OH}$  and  $I_{OL}$ , respectively. The indicated HIGH/LOW drive factors of 25/12.5 translate to 1.0 mA and 20 mA by multiplying them by 40  $\mu$ A and 1.6 mA, respectively.

**Input Loading/Fan-Out:** See Section 3 for U.L. definitions

Pin Names	Description	54F/74F (U.L.) HIGH/LOW
	Inputs	0.5/0.375
	Outputs	25/12.5

### Absolute Maximum Ratings<sup>1</sup>

(beyond which useful life may be impaired)

Storage Temperature	-65°C to +150°C
Ambient Temperature under Bias	-55°C to +125°C
Junction Temperature under Bias	-55°C to +175°C
V <sub>CC</sub> Pin Potential to Ground Pin	-0.5 V to +7.0 V
Input Voltage <sup>2</sup>	-0.5 V to +7.0 V
Input Current <sup>2</sup>	-30 mA to +5.0 mA
Voltage Applied to Output in HIGH State:	
Standard Output	-0.5 V to V <sub>CC</sub> Value
3-State Output (with V <sub>CC</sub> = 0 V)	-0.5 V to +5.5 V
Current Applied to Output in LOW State (Max)	twice the rated I <sub>OL</sub>

### Recommended Operating Conditions<sup>1</sup>

	Min	Max
Free Air Ambient Temperature		
Military (XM)	-55°C	+125°C
Commercial (XC)	0°C	+70°C
Supply Voltage		
Military (XM)	+4.5 V	+5.5 V
Commercial (XC)	+4.75 V	+5.25 V

1. Unless otherwise restricted or extended by detail specifications.
2. Either input voltage or current limit sufficient to protect inputs.



**54F/74F Family DC Characteristics<sup>1</sup>**

Symbol	Parameter		Limits <sup>2</sup>			Units	V <sub>CC</sub> <sup>4</sup>	Conditions <sup>2</sup>	
			Min	Typ <sup>3</sup>	Max				
V <sub>IH</sub>	Input HIGH Voltage		2.0			V		Recognized as a HIGH Signal over Recommended V <sub>CC</sub> and T <sub>A</sub> Range	
V <sub>IL</sub>	Input LOW Voltage		0.8			V		Recognized as a LOW Signal over Recommended V <sub>CC</sub> and T <sub>A</sub> Range	
V <sub>CD</sub>	Input Clamp Diode Voltage		-1.2			V	Min	I <sub>IN</sub> = -18 mA	
V <sub>OH</sub>	Output HIGH Voltage	Std 6 Mil	2.5	3.4		V	Min	I <sub>OH</sub> = 40 μA Multiplied by Output HIGH U.L. Shown on Data Sheet	
		Std 6 Com	2.7	3.4					
V <sub>OL</sub>	Output LOW Voltage		0.35	0.5		V	Min	I <sub>OL</sub> = 1.6 mA Multiplied by Output LOW U.L. Shown on Data Sheet	
I <sub>IH</sub>	Input HIGH Current		0.5 U.L.			μA	Max	I <sub>IH</sub> = 40 μA Multiplied by Input HIGH U.L. Shown on Data Sheet; V <sub>IN</sub> = 2.7 V	
			1.0 U.L.						20
			n U.L.						40 n(40)
	Input HIGH Current, Breakdown Test, All Inputs				100	μA	Max	V <sub>IN</sub> = 7.0 V	
I <sub>IL</sub>	Input LOW Current		0.375 U.L.			mA	Max	I <sub>IL</sub> = -1.6 mA Multiplied by Input LOW U.L. Shown on Data Sheet; V <sub>IN</sub> = 0.5 V	
			0.75 U.L.						-0.6
			n U.L.						-1.2 n(-1.6)
I <sub>OZH</sub>	3-State Output OFF Current HIGH				50	μA	Max	V <sub>OUT</sub> = 2.4 V	
I <sub>OZL</sub>	3-State Output OFF Current LOW				-50	μA	Max	V <sub>OUT</sub> = 0.5 V	
I <sub>OS</sub> <sup>5</sup>	Output Short-Circuit Current	Standard <sup>6</sup> / 3-State	-60	-150		mA	Max	V <sub>OUT</sub> = 0 V	
		Buffers/ Line Dvrs	-100	-225					

1. Unless otherwise noted, conditions and limits apply throughout the temperature range for which the particular device type is rated. The ground pin is the reference level for all applied and resultant voltages.
2. Unless otherwise stated on individual data sheets.
3. Typical characteristics refer to T<sub>A</sub> = +25°C and V<sub>CC</sub> = +5.0 V.
4. Min and Max refer to the values listed in the table of recommended operating conditions.
5. For testing I<sub>OS</sub>, the use of high-speed test apparatus and/or sample-and-hold techniques are preferable in order to minimize internal heating and more accurately reflect operational values. Otherwise, prolonged shorting of a HIGH output may raise the chip temperature well above normal and thereby cause invalid readings in other parameter tests. In any sequence of parameter tests, I<sub>OS</sub> tests should be performed last.
6. Standard refers to the totem-pole pull-up circuitry commonly used for the particular family, as distinguished from buffers, line drivers or 3-state outputs.

## AC Loading and Waveforms

Figure 3-1 shows the ac loading circuit used in characterizing and specifying propagation delays of all FAST devices, unless otherwise specified in the data sheet of a specific device. The use of this load, which differs somewhat from previous practice, provides more meaningful information and minimizes problems of instrumentation and customer correlation. In the 1980 edition of the FAST data book, the +25°C propagation delays were specified with a load of 15 pF to ground; this required great care in building test jigs to minimize stray capacitance, and implied the use of high-impedance, high-frequency scope probes. Changing to 50 pF of capacitance allows more leeway in stray capacitance and also loads the device during rising or falling output transitions, which more closely resembles the loading to be expected in average applications and thus gives the designer more useful delay figures. The net effect of the change in ac load is to increase the observed propagation delay by an average of about 1 ns.

The 500  $\Omega$  resistor to ground, in Figure 3-1, acts as a ballast, to slightly load the totem-pole pull-up and limit the quiescent HIGH-state voltage to about +3.5 V. Otherwise, an output would rise quickly to about +3.5 V but then continue to rise very slowly on up to about +4.4 V. On the subsequent HIGH-to-LOW transition the observed  $t_{PHL}$  would vary slightly with duty cycle, depending on how long the output voltage was allowed to rise before switching to the LOW state. Perhaps more importantly, the 500  $\Omega$  resistor to ground can be a high frequency passive probe for a sampling scope, which costs much less than the equivalent high-impedance probe. Alternatively, the 500  $\Omega$  load to ground can simply be a 450  $\Omega$  resistor feeding into a 50  $\Omega$  coaxial cable leading to a sampling scope input connector, with the internal 50  $\Omega$  termination of the scope completing the path to ground. Note that with this scheme there should be a matching cable from the device input pin to the other input of the sampling scope; this also serves as a 50  $\Omega$  termination for the pulse generator that supplies the input signal.

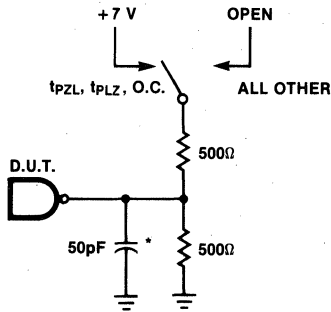
Also shown in Figure 3-1 is a second 500  $\Omega$  resistor from the device output to a switch. For most measurements this switch is open; it is closed for measuring a device with open-collector outputs and for measuring one set of the Enable/Disable parameters (LOW-to-OFF and OFF-to-LOW) of a 3-state output. With the switch closed, the pair of 500  $\Omega$  resistors and the +7.0 V supply establish a quiescent HIGH level of +3.5 V, which correlates with the HIGH level discussed in the preceding paragraph.

Another change from the 1980 FAST data book involves the measurement criteria for the Disable times of 3-state outputs. Figures 3-12 and 3-13 show that the Disable times are measured at the point where the output voltage has risen or fallen by 0.3 V from the quiescent level (i.e., LOW for  $t_{PLZ}$  or HIGH for  $t_{PHZ}$ ), compared to a  $\Delta V$  of 0.5 V used in previous practice. This change enhances the repeatability of measurements and gives the system designer more realistic delay times to use in calculating minimum cycle times. Since the rising or falling waveform is RC-controlled, the first 0.3 V of change is more linear than the first 0.5 V and is less susceptible to external influences. More importantly, perhaps, from the system designer's point of view, a  $\Delta V$  of 0.3 V is adequate to ensure that a device output has turned OFF; measuring to a  $\Delta V$  of 0.5 V merely exaggerates the apparent Disable time and thus penalizes system performance, since the designer must use the Enable and Disable times to devise worst-case timing signals to ensure that the output of one device is disabled before that of another device is enabled.

Good high-frequency wiring practices should be used in constructing test jigs. Leads on the load capacitor should be as short as possible, to minimize ripples on the output waveform transitions and to minimize undershoot. Generous ground metal (preferably a ground plane) should be used, for the same reasons. A  $V_{CC}$  bypass capacitor should be provided at the test socket, also with minimum lead lengths. Input signals should have rise and fall times of 2.5 ns and signal swing of 0 V to +3.0 V. A 1.0 MHz square wave is recommended for most propagation delay tests. The repetition rate must necessarily be increased for testing  $f_{max}$ . Two pulse generators are usually required for testing such parameters as setup time, hold time, recovery time, etc.

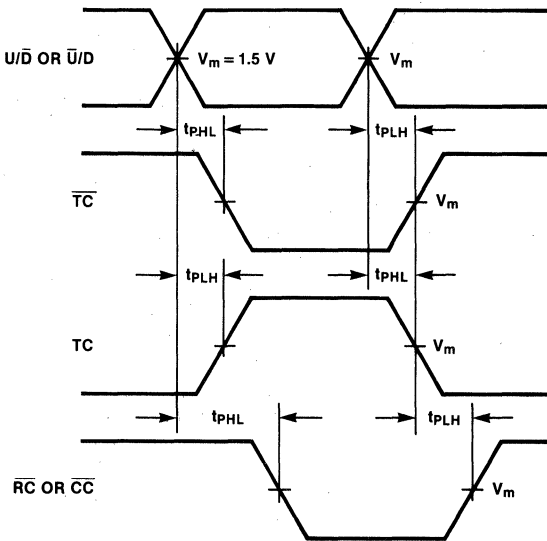
Precautions should be taken to prevent damage to devices by electrostatic charge. Static charge tends to accumulate on insulated surfaces, such as synthetic fabrics or carpeting, plastic sheets, trays, foam, tubes or bags, and on ungrounded electrical tools or appliances. The problem is much worse in a dry atmosphere. In general, it is recommended that individuals take the precaution of touching a known ground before handling devices. In extremely adverse environments, it may be necessary for individuals to wear a grounded wrist strap when handling devices.

**Fig. 3-1 Test Load**

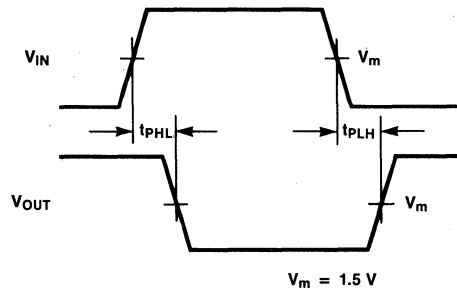


\*INCLUDES JIG AND PROBE CAPACITANCE

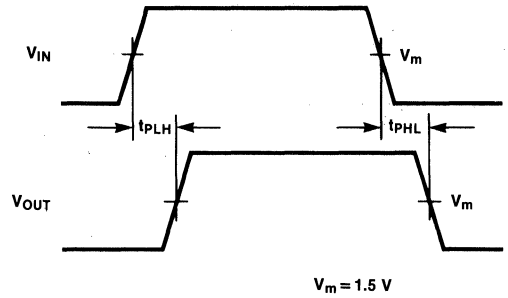
**Fig. 3-2 Propagation Delays from Up/Down Control**



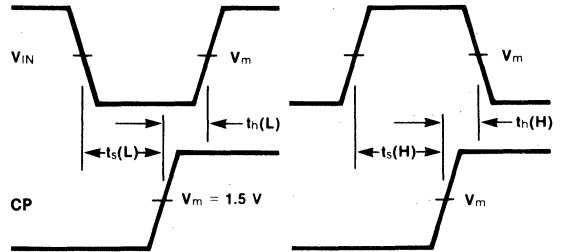
**Fig. 3-3 Waveform for Inverting Functions**



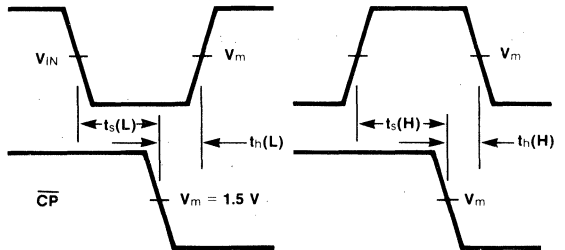
**Fig. 3-4 Waveform for Non-inverting Functions**



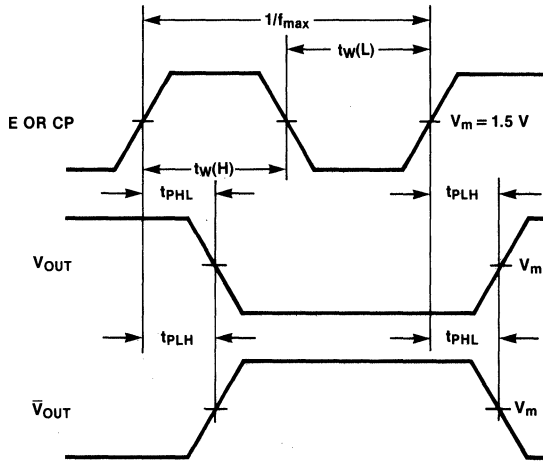
**Fig. 3-5 Setup and Hold Times, Rising-edge Clock**



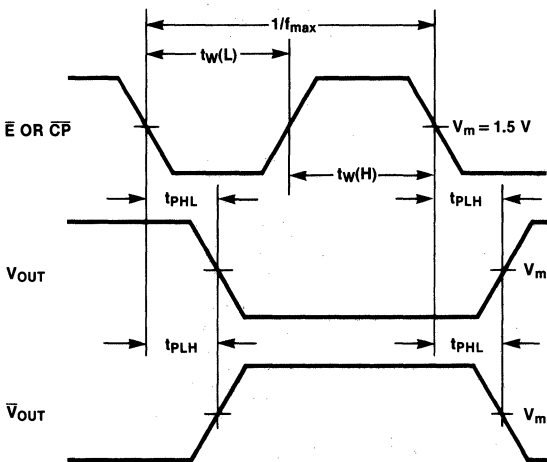
**Fig. 3-6 Setup and Hold Times, Falling-edge Clock**



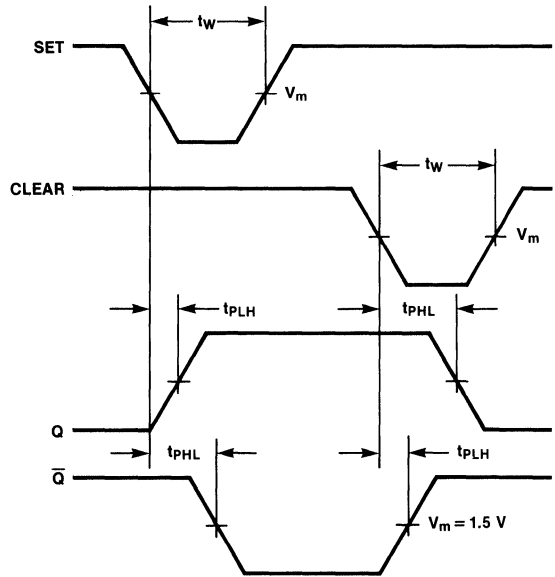
**Fig. 3-7 Propagation Delays from Rising-edge Clock or Enable**



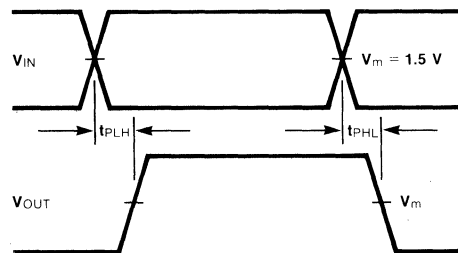
**Fig. 3-8 Propagation Delays from Falling-edge Clock or Enable**



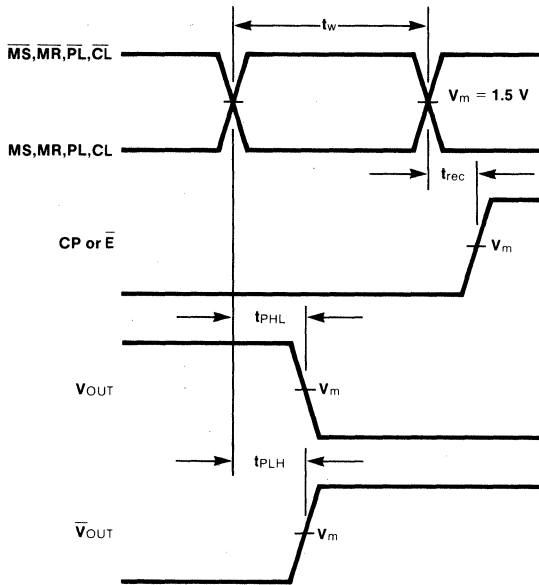
**Fig. 3-9 Propagation Delays from Set and Clear (or Reset)**



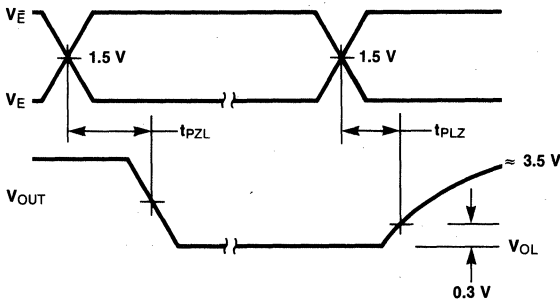
**Fig. 3-10 Whether Response Is Inverting or Non-Inverting Depends on Specific Truth Table Conditions**



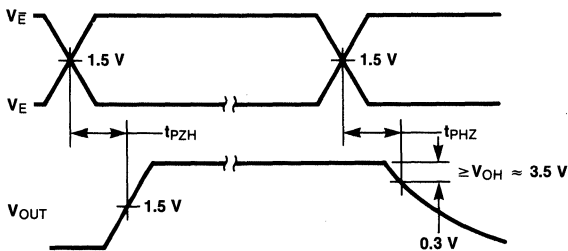
**Fig. 3-11 Asynchronous Set, Reset, Parallel Load or Clear, Active Rising-edge Clock or Active-LOW Enable**



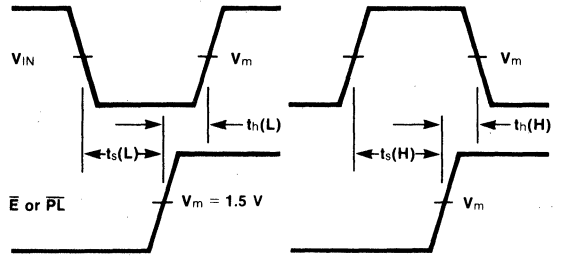
**Fig. 3-12 3-State Output LOW Enable and Disable Times**



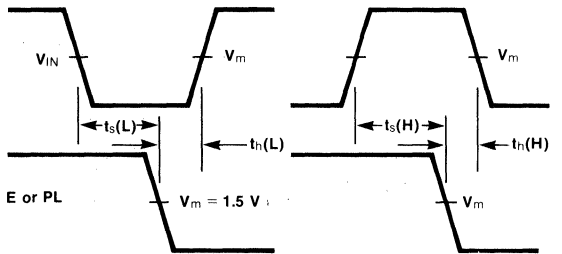
**Fig. 3-13 3-State Output HIGH Enable and Disable Times**



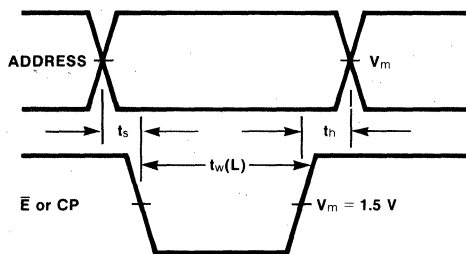
**Fig. 3-14 Setup and Hold Times to Active-LOW Enable or Parallel Load**

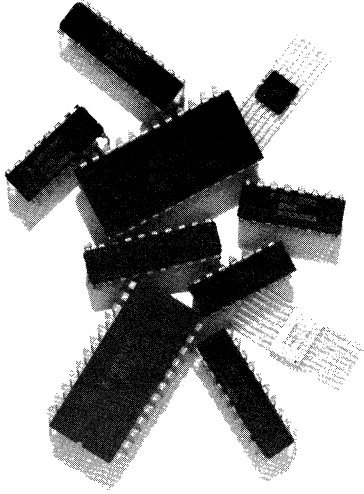


**Fig. 3-15 Setup and Hold Times to Active-HIGH Enable or Parallel Load**



**Fig. 3-16 Storage Address Setup and Hold Times**





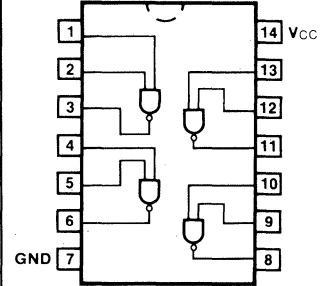
<b>Product Index and Selection Guide</b>	<b>1</b>
<b>Circuit Characteristics</b>	<b>2</b>
<b>Ratings, Specifications and Waveforms</b>	<b>3</b>
<b>Data Sheets</b>	<b>4</b>
<b>New Products</b>	<b>5</b>
<b>Ordering Information and Package Outlines</b>	<b>6</b>
<b>Sales Offices, Representatives and Distributor Locations</b>	<b>7</b>



# 54F/74F00

Quad 2-Input NAND Gate

## Connection Diagram



Ordering Code: See Section 6

Pkgs	Commercial Grade	Military Grade	Pkg Type
	$V_{CC} = +5.0\text{ V} \pm 5\%$ , $T_A = 0^\circ\text{C to } +70^\circ\text{C}$	$V_{CC} = +5.0\text{ V} \pm 10\%$ , $T_A = -55^\circ\text{C to } +125^\circ\text{C}$	
Plastic DIP (P)	74F00PC		9A
Ceramic DIP (D)	74F00DC	54F00DM	6A
Flatpak (F)		54F00FM	3I

4

Input Loading/Fan-Out: See Section 3 for U.L. definitions

Pin Names	Description	54F/74F (U.L.) HIGH/LOW
Inputs		0.5/0.375
Outputs		25/12.5

DC Characteristics over Operating Temperature Range (unless otherwise specified)

Symbol	Parameter	54F/74F			Units	Conditions	
		Min	Typ	Max		$V_{IN} = \text{Gnd}$	$V_{CC} = \text{Max}$
$I_{CCH}$ $I_{CCL}$	Power Supply Current		1.9 6.8	2.8 10.2	mA		

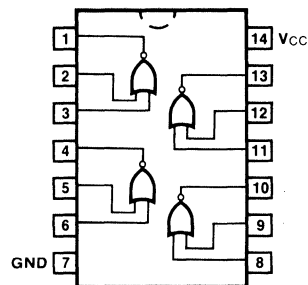
AC Characteristics: See Section 3 for waveforms and load configurations

Symbol	Parameter	54F/74F			54F		74F		Units	Fig. No.
		$T_A = +25^\circ\text{C}$ , $V_{CC} = +5.0\text{ V}$ $C_L = 50\text{ pF}$			$T_A, V_{CC} = \text{Mil}$ $C_L = 50\text{ pF}$		$T_A, V_{CC} = \text{Com}$ $C_L = 50\text{ pF}$			
		Min	Typ	Max	Min	Max	Min	Max		
$t_{PLH}$ $t_{PHL}$	Propagation Delay	2.4 2.0	3.7 3.2	5.0 4.3	2.0 1.5	7.0 6.5	2.4 2.0	6.0 5.3	ns	3-1 3-3



**54F/74F02**

Quad 2-Input NOR Gate

**Connection Diagram****Ordering Code:** See Section 6

Pkgs	Commercial Grade	Military Grade	Pkg Type
	$V_{CC} = +5.0\text{ V} \pm 5\%$ , $T_A = 0^\circ\text{C to } +70^\circ\text{C}$	$V_{CC} = +5.0\text{ V} \pm 10\%$ , $T_A = -55^\circ\text{C to } +125^\circ\text{C}$	
Plastic DIP (P)	74F02PC		9A
Ceramic DIP (D)	74F02DC	54F02DM	6A
Flatpak (F)		54F02FM	3I

**Input Loading/Fan-Out:** See Section 3 for U.L. definitions

Pin Names	Description	54F/74F (U.L.) HIGH/LOW
	Inputs	0.5/0.375
	Outputs	25/12.5

**DC Characteristics over Operating Temperature Range** (unless otherwise specified)

Symbol	Parameter	54F/74F			Units	Conditions	
		Min	Typ	Max		$V_{IN} = \text{Gnd}$ *	$V_{CC} = \text{Max}$
$I_{CCH}$ $I_{CCL}$	Power Supply Current		3.7 8.7	5.6 13	mA		

**AC Characteristics:** See Section 3 for waveforms and load configurations

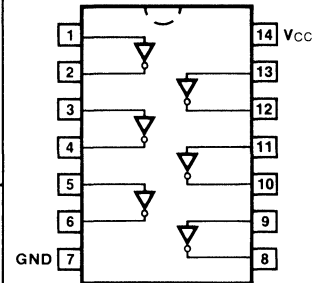
Symbol	Parameter	54F/74F			54F		74F		Units	Fig. No.
		$T_A = +25^\circ\text{C}$ $V_{CC} = +5.0\text{ V}$ $C_L = 50\text{ pF}$			$T_A, V_{CC} = \text{Mil}$ $C_L = 50\text{ pF}$		$T_A, V_{CC} = \text{Com}$ $C_L = 50\text{ pF}$			
		Min	Typ	Max	Min	Max	Min	Max		
$t_{PLH}$ $t_{PHL}$	Propagation Delay	2.5 2.0	4.4 3.2	5.5 4.3	2.5 1.5	7.5 6.5	2.5 2.0	6.5 5.3	ns	3-1 3-3

\*Measured with one input HIGH, one input LOW for each gate.

**54F/74F04**

Hex Inverter

Connection Diagram



Ordering Code: See Section 6

Pkgs	Commercial Grade	Military Grade	Pkg Type
	$V_{CC} = +5.0\text{ V} \pm 5\%$ , $T_A = 0^\circ\text{C to } +70^\circ\text{C}$	$V_{CC} = +5.0\text{ V} \pm 10\%$ , $T_A = -55^\circ\text{C to } +125^\circ\text{C}$	
Plastic DIP (P)	74F04PC		9A
Ceramic DIP (D)	74F04DC	54F04DM	6A
Flatpak (F)		54F04FM	3I

4

Input Loading/Fan-Out: See Section 3 for U.L. definitions

Pin Names	Description	54F/74F (U.L.) HIGH/LOW
Inputs		0.5/0.375
Outputs		25/12.5

DC Characteristics over Operating Temperature Range (unless otherwise specified)

Symbol	Parameter	54F/74F			Units	Conditions	
		Min	Typ	Max			
$I_{CCH}$ $I_{CCL}$	Power Supply Current		2.8 10.2	4.2 15.3	mA	$V_{IN} = \text{Gnd}$ $V_{IN} = \text{Open}$	$V_{CC} = \text{Max}$

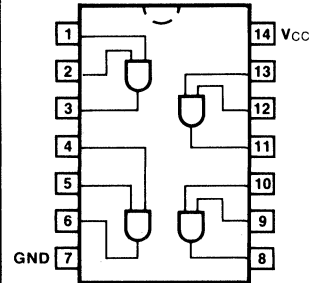
AC Characteristics: See Section 3 for waveforms and load configurations

Symbol	Parameter	54F/74F			54F		74F		Units	Fig. No.
		$T_A = +25^\circ\text{C}$ , $V_{CC} = +5.0\text{ V}$ $C_L = 50\text{ pF}$			$T_A, V_{CC} = \text{Mil}$ $C_L = 50\text{ pF}$		$T_A, V_{CC} = \text{Com}$ $C_L = 50\text{ pF}$			
		Min	Typ	Max	Min	Max	Min	Max		
$t_{PLH}$ $t_{PHL}$	Propagation Delay	2.4 2.0	3.7 3.2	5.0 4.3	2.0 1.5	7.0 6.5	2.4 2.0	6.0 5.3	ns	3-1 3-3

**54F/74F08**

Quad 2-Input AND Gate

## Connection Diagram



Ordering Code: See Section 6

Pkgs	Commercial Grade	Military Grade	Pkg Type
	$V_{CC} = +5.0 \text{ V} \pm 5\%$ , $T_A = 0^\circ\text{C to } +70^\circ\text{C}$	$V_{CC} = +5.0 \text{ V} \pm 10\%$ , $T_A = -55^\circ\text{C to } +125^\circ\text{C}$	
Plastic DIP (P)	74F08PC		9A
Ceramic DIP (D)	74F08DC	54F08DM	6A
Flatpak (F)		54F08FM	3I

Input Loading/Fan-Out: See Section 3 for U.L. definitions

Pin Names	Description	54F/74F (U.L.) HIGH/LOW
	Inputs	0.5/0.375
	Outputs	25/12.5

DC Characteristics over Operating Temperature Range (unless otherwise specified)

Symbol	Parameter	54F/74F			Units	Conditions	
		Min	Typ	Max		$V_{IN} = \text{Open}$	$V_{CC} = \text{Max}$
$I_{CCH}$	Power Supply Current		5.5	8.3	mA	$V_{IN} = \text{Open}$	$V_{CC} = \text{Max}$
$I_{CCL}$			8.6	12.9		$V_{IN} = \text{Gnd}$	

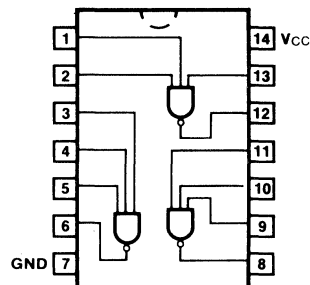
AC Characteristics: See Section 3 for waveforms and load configurations

Symbol	Parameter	54F/74F			54F		74F		Units	Fig. No.
		$T_A = +25^\circ\text{C}$ , $V_{CC} = +5.0 \text{ V}$ $C_L = 50 \text{ pF}$			$T_A, V_{CC} = \text{Mil}$ $C_L = 50 \text{ pF}$		$T_A, V_{CC} = \text{Com}$ $C_L = 50 \text{ pF}$			
		Min	Typ	Max	Min	Max	Min	Max		
$t_{PLH}$	Propagation Delay	3.0	4.2	5.6	2.5	7.5	3.0	6.6	ns	3-1
$t_{PHL}$		2.5	4.0	5.3	2.0	7.5	2.5	6.3		3-4

# 54F/74F10

Triple 3-Input NAND Gate

## Connection Diagram



Ordering Code: See Section 6

Pkgs	Commercial Grade	Military Grade	Pkg Type
	$V_{CC} = +5.0\text{ V} \pm 5\%$ , $T_A = 0^\circ\text{C to } +70^\circ\text{C}$	$V_{CC} = +5.0\text{ V} \pm 10\%$ , $T_A = -55^\circ\text{C to } +125^\circ\text{C}$	
Plastic DIP (P)	74F10PC		9A
Ceramic DIP (D)	74F10DC	54F10DM	6A
Flatpak (F)		54F10FM	3I

4

Input Loading/Fan-Out: See Section 3 for U.L. definitions

Pin Names	Description	54F/74F (U.L.) HIGH/LOW
	Inputs	0.5/0.375
	Outputs	25/12.5

DC Characteristics over Operating Temperature Range (unless otherwise specified)

Symbol	Parameter	54F/74F			Units	Conditions	
		Min	Typ	Max		$V_{IN} = \text{Gnd}$	$V_{CC} = \text{Max}$
$I_{CCH}$ $I_{CCL}$	Power Supply Current		1.4 5.1	2.1 7.7	mA	$V_{IN} = \text{Gnd}$	$V_{CC} = \text{Max}$
						$V_{IN} = \text{Open}$	

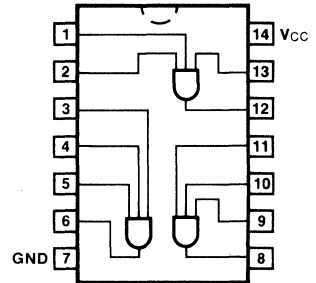
AC Characteristics: See Section 3 for waveforms and load configurations

Symbol	Parameter	54F/74F			54F		74F		Units	Fig. No.
		$T_A = +25^\circ\text{C}$ , $V_{CC} = +5.0\text{ V}$ $C_L = 50\text{ pF}$			$T_A, V_{CC} = \text{Mil}$ $C_L = 50\text{ pF}$		$T_A, V_{CC} = \text{Com}$ $C_L = 50\text{ pF}$			
		Min	Typ	Max	Min	Max	Min	Max		
$t_{PLH}$ $t_{PHL}$	Propagation Delay	2.4 2.0	3.7 3.2	5.0 4.3	2.0 1.5	7.0 6.5	2.4 2.0	6.0 5.3	ns	3-1 3-3

**54F/74F11**

Triple 3-Input AND Gate

## Connection Diagram



Ordering Code: See Section 6

Pkgs	Commercial Grade	Military Grade	Pkg Type
	$V_{CC} = +5.0\text{ V} \pm 5\%$ , $T_A = 0^\circ\text{C to } +70^\circ\text{C}$	$V_{CC} = +5.0\text{ V} \pm 10\%$ , $T_A = -55^\circ\text{C to } +125^\circ\text{C}$	
Plastic DIP (P)	74F11PC		9A
Ceramic DIP (D)	74F11DC	54F11DM	6A
Flatpak (F)		54F11FM	3I

Input Loading/Fan-Out: See Section 3 for U.L. definitions

Pin Names	Description	54F/74F (U.L.) HIGH/LOW
Inputs		0.5/0.375
Outputs		25/12.5

DC Characteristics over Operating Temperature Range (unless otherwise specified)

Symbol	Parameter	54F/74F			Units	Conditions	
		Min	Typ	Max		$V_{IN} = \text{Open}$	$V_{CC} = \text{Max}$
$I_{CCH}$ $I_{CCL}$	Power Supply Current		4.1	6.2	mA	$V_{IN} = \text{Open}$	$V_{CC} = \text{Max}$
			6.5	9.7		$V_{IN} = \text{Gnd}$	

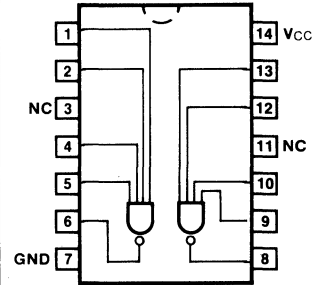
AC Characteristics: See Section 3 for waveforms and load configurations

Symbol	Parameter	54F/74F			54F		74F		Units	Fig. No.
		$T_A = +25^\circ\text{C}$ , $V_{CC} = +5.0\text{ V}$ $C_L = 50\text{ pF}$			$T_A, V_{CC} = \text{Mil}$ $C_L = 50\text{ pF}$		$T_A, V_{CC} = \text{Com}$ $C_L = 50\text{ pF}$			
		Min	Typ	Max	Min	Max	Min	Max		
$t_{PLH}$ $t_{PHL}$	Propagation Delay	3.0	4.2	5.6	2.5	7.5	3.0	6.6	ns	3-1
		2.5	4.1	5.5	2.0	7.5	2.5	6.5		3-4

# 54F/74F20

## Dual 4-Input NAND Gate

### Connection Diagram



Ordering Code: See Section 6

Pkgs	Commercial Grade	Military Grade	Pkg Type
	V <sub>CC</sub> = +5.0 V ±5%, T <sub>A</sub> = 0° C to +70° C	V <sub>CC</sub> = +5.0 V ±10%, T <sub>A</sub> = -55° C to +125° C	
Plastic DIP (P)	74F20PC		9A
Ceramic DIP (D)	74F20DC	54F20DM	6A
Flatpak (F)		54F20FM	3I

4

Input Loading/Fan-Out: See Section 3 for U.L. definitions

Pin Names	Description	54F/74F (U.L.) HIGH/LOW
	Inputs	0.5/0.375
	Outputs	25/12.5

DC Characteristics over Operating Temperature Range (unless otherwise specified)

Symbol	Parameter	54F/74F			Units	Conditions	
		Min	Typ	Max		V <sub>CC</sub> = Max	V <sub>IN</sub> = Gnd V <sub>IN</sub> = Open
I <sub>CCH</sub>	Power Supply Current		0.9	1.4	mA		
I <sub>CCL</sub>			3.4	5.1		V <sub>IN</sub> = Open	

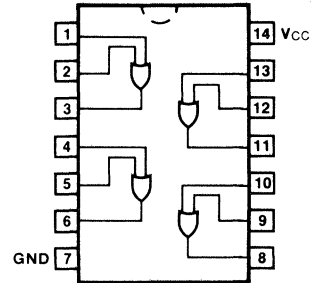
AC Characteristics: See Section 3 for waveforms and load configurations

Symbol	Parameter	54F/74F			54F		74F		Units	Fig. No.
		T <sub>A</sub> = +25° C, V <sub>CC</sub> = +5.0 V C <sub>L</sub> = 50 pF			T <sub>A</sub> , V <sub>CC</sub> = Mil C <sub>L</sub> = 50 pF		T <sub>A</sub> , V <sub>CC</sub> = Com C <sub>L</sub> = 50 pF			
		Min	Typ	Max	Min	Max	Min	Max		
t <sub>PLH</sub>	Propagation Delay	2.4	3.7	5.0	2.0	7.0	2.4	6.0	ns	3-1 3-3
t <sub>PHL</sub>		2.0	3.2	4.3	1.5	6.5	2.0	5.3		

**54F/74F32**

Quad 2-Input OR Gate

## Connection Diagram



Ordering Code: See Section 6

Pkgs	Commercial Grade	Military Grade	Pkg Type
	$V_{CC} = +5.0\text{ V} \pm 5\%$ , $T_A = 0^\circ\text{ C to } +70^\circ\text{ C}$	$V_{CC} = +5.0\text{ V} \pm 10\%$ , $T_A = -55^\circ\text{ C to } +125^\circ\text{ C}$	
Plastic DIP (P)	74F32PC		9A
Ceramic DIP (D)	74F32DC	54F32DM	6A
Flatpak (F)		54F32FM	3I

Input Loading/Fan-Out: See Section 3 for U.L. definitions

Pin Names	Description	54F/74F (U.L.) HIGH/LOW
Inputs		0.5/0.375
Outputs		25/12.5

DC Characteristics over Operating Temperature Range (unless otherwise specified)

Symbol	Parameter	54F/74F			Units	Conditions	
		Min	Typ	Max		$V_{IN} = \text{Open}$	$V_{CC} = \text{Max}$
$I_{CCH}$	Power Supply Current		6.1	9.2	mA	$V_{IN} = \text{Open}$	$V_{CC} = \text{Max}$
$I_{CCL}$			10.3	15.5		$V_{IN} = \text{Gnd}$	

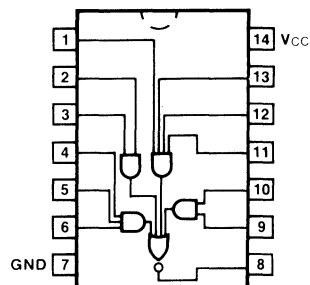
AC Characteristics: See Section 3 for waveforms and load configurations

Symbol	Parameter	54F/74F			54F		74F		Units	Fig. No.
		$T_A = +25^\circ\text{ C}$ , $V_{CC} = +5.0\text{ V}$ $C_L = 50\text{ pF}$			$T_A, V_{CC} = \text{Mil}$ $C_L = 50\text{ pF}$		$T_A, V_{CC} = \text{Com}$ $C_L = 50\text{ pF}$			
		Min	Typ	Max	Min	Max	Min	Max		
$t_{PLH}$	Propagation Delay	3.0	4.2	5.6	3.0	7.5	3.0	6.6	ns	3-1
$t_{PHL}$		3.0	4.0	5.3	2.5	7.5	3.0	6.3		3-4

**54F/74F64**

4-2-3-2-Input AND OR-Invert Gate

## Connection Diagram



Ordering Code: See Section 6

Pkgs	Commercial Grade	Military Grade	Pkg Type
	$V_{CC} = +5.0 \text{ V} \pm 5\%$ , $T_A = 0^\circ\text{C to } +70^\circ\text{C}$	$V_{CC} = +5.0 \text{ V} \pm 10\%$ , $T_A = -55^\circ\text{C to } +125^\circ\text{C}$	
Plastic DIP (P)	74F64PC		9A
Ceramic DIP (P)	74F64DC	54F64DM	6A
Flatpak (F)		54F64FM	3I

Input Loading/Fan-Out: See Section 3 for U.L. definitions

Pin Names	Description	54F/74F (U.L.) HIGH/LOW
	Inputs	0.5/0.375
	Outputs	25/12.5

DC Characteristics over Operating Temperature Range (unless otherwise specified)

Symbol	Parameter	54F/74F			Units	Conditions	
		Min	Typ	Max		$V_{IN} = \text{Gnd}$ *	$V_{CC} = \text{Max}$
$I_{CCH}$ $I_{CCL}$	Power Supply Current		1.9 3.1	2.8 4.7	mA		

AC Characteristics: See Section 3 for waveforms and load configurations

Symbol	Parameter	54F/74F			54F		74F		Units	Fig. No.
		$T_A = +25^\circ\text{C}$ , $V_{CC} = +5.0 \text{ V}$ $C_L = 50 \text{ pF}$			$T_A, V_{CC} =$ Mil $C_L = 50 \text{ pF}$		$T_A, V_{CC} =$ Com $C_L = 50 \text{ pF}$			
		Min	Typ	Max	Min	Max	Min	Max		
$t_{PLH}$ $t_{PHL}$	Propagation Delay	2.5 2.0	4.6 3.2	6.0 4.5	2.5 1.5	8.0 6.5	2.5 2.0	7.0 5.5	ns	3-1 3-3

\* $I_{CCL}$  is measured with all inputs of one gate open and remaining inputs grounded.



# 54F/74F74

## Dual D-Type Positive Edge-Triggered Flip-Flop

### Description

The 'F74 is a dual D-type flip-flop with Direct Clear and Set inputs and complementary (Q,  $\bar{Q}$ ) outputs. Information at the input is transferred to the outputs on the positive edge of the clock pulse. Clock triggering occurs at a voltage level of the clock pulse and is not directly related to the transition time of the positive-going pulse. After the Clock Pulse input threshold voltage has been passed, the Data input is locked out and information present will not be transferred to the outputs until the next rising edge of the Clock Pulse input.

### Truth Table

(Each Half)

INPUT	OUTPUTS	
@ $t_n$	@ $t_{n+1}$	
D	Q	$\bar{Q}$
L	L	H
H	H	L

### Asynchronous Inputs:

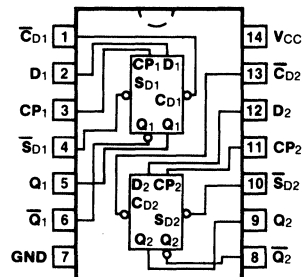
- LOW input to  $\bar{S}_D$  sets Q to HIGH level
- LOW input to  $\bar{C}_D$  sets Q to LOW level
- Clear and Set are independent of clock
- Simultaneous LOW on  $\bar{C}_D$  and  $\bar{S}_D$  makes both Q and  $\bar{Q}$  HIGH

H = HIGH Voltage Level  
 L = LOW Voltage Level  
 $t_n$  = Bit time before clock pulse  
 $t_{n+1}$  = Bit time after clock pulse

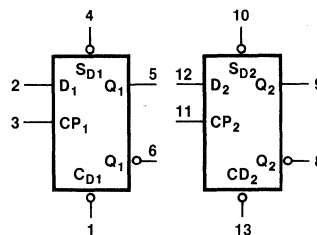
Ordering Code: See Section 6

Pkgs	Commercial Grade	Military Grade	Pkg Type
	$V_{CC} = +5.0 \text{ V} \pm 5\%$ , $T_A = 0^\circ \text{C to } +70^\circ \text{C}$	$V_{CC} = +5.0 \text{ V} \pm 10\%$ , $T_A = -55^\circ \text{C to } +125^\circ \text{C}$	
Plastic DIP (P)	74F74PC		9A
Ceramic DIP (D)	74F74DC	54F74DM	6A
Flatpak (F)		54F74FM	3I

### Connection Diagram



### Logic Symbol

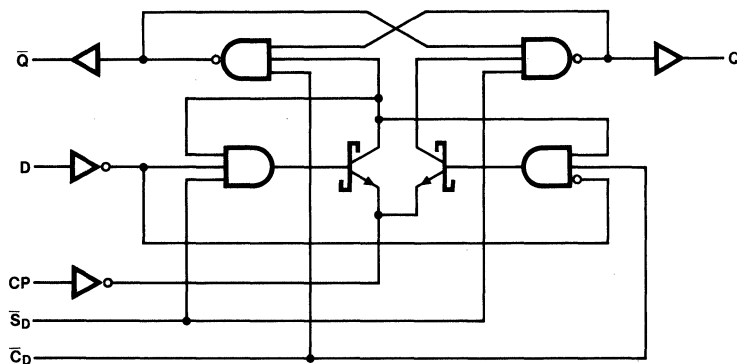


$V_{CC}$  = Pin 14  
 GND = Pin 7

Input Loading/Fan-Out: See Section 3 for U.L. definitions

Pin Names	Description	54F/74F (U.L.) HIGH/LOW
D1, D2	Data Inputs	0.5/0.375
CP1, CP2	Clock Pulse Inputs (Active Rising Edge)	0.5/0.375
$\bar{C}_D1, \bar{C}_D2$	Direct Clear Inputs (Active LOW)	0.5/1.125
$\bar{S}_D1, \bar{S}_D2$	Direct Set Inputs (Active LOW)	0.5/1.125
Q1, $\bar{Q}_1, Q2, \bar{Q}_2$	Outputs	25/12.5

## Logic Diagram



Please note that this diagram is provided only for the understanding of logic operations and should not be used to estimate propagation delays.

4

## DC Characteristics over Operating Temperature Range (unless otherwise specified)

Symbol	Parameter	54F/74F			Units	Conditions
		Min	Typ	Max		
$I_{CC}$	Power Supply Current		10.5	16	mA	$V_{CC} = \text{Max}, V_{CP} = 0 \text{ V}$

## AC Characteristics: See Section 3 for waveforms and load configurations

Symbol	Parameter	54F/74F			54F		74F		Units	Fig. No.
		$T_A = +25^\circ\text{C}, V_{CC} = +5.0 \text{ V}, C_L = 50 \text{ pF}$			$T_A, V_{CC} = \text{Mil}, C_L = 50 \text{ pF}$		$T_A, V_{CC} = \text{Com}, C_L = 50 \text{ pF}$			
		Min	Typ	Max	Min	Max	Min	Max		
$f_{\text{max}}$	Maximum Clock Frequency	100	125		100		100	MHz	3-1, 3-7	
$t_{\text{PLH}}$	Propagation Delay	3.8	5.3	6.8	3.8	8.5	3.8	7.8	ns	3-1
$t_{\text{PHL}}$	$CP_n$ to $Q_n$ or $\overline{Q}_n$	4.4	6.2	8.0	4.4	10.5	4.4	9.2		3-7
$t_{\text{PLH}}$	Propagation Delay	3.2	4.6	6.1	3.2	8.0	3.2	7.1	ns	3-1
$t_{\text{PHL}}$	$\overline{C}_{Dn}$ or $\overline{S}_{Dn}$ to $Q_n$ or $\overline{Q}_n$	3.5	7.0	9.0	3.5	11.5	3.5	10.5		3-9

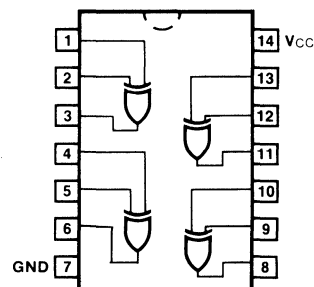
## AC Operating Requirements: See Section 3 for waveforms

Symbol	Parameter	54F/74F			54F		74F		Units	Fig. No.
		T <sub>A</sub> = +25°C, V <sub>CC</sub> = +5.0 V			T <sub>A</sub> , V <sub>CC</sub> = Mil		T <sub>A</sub> , V <sub>CC</sub> = Com			
		Min	Typ	Max	Min	Max	Min	Max		
t <sub>s</sub> (H) t <sub>s</sub> (L)	Setup Time, HIGH or LOW D <sub>n</sub> to CP <sub>n</sub>	2.0			3.0		2.0		ns	3-5
		3.0			4.0		3.0			
t <sub>h</sub> (H) t <sub>h</sub> (L)	Hold Time, HIGH or LOW D <sub>n</sub> to CP <sub>n</sub>	1.0			2.0		1.0			
		1.0			2.0		1.0			
t <sub>w</sub> (H) t <sub>w</sub> (L)	CP <sub>n</sub> Pulse Width, HIGH or LOW	4.0			4.0		4.0		ns	3-7
		5.0			6.0		5.0			
t <sub>w</sub> (L)	$\overline{C}_{Dn}$ or $\overline{S}_{Dn}$ Pulse Width LOW	4.0			4.0		4.0		ns	3-9
t <sub>rec</sub>	Recovery Time $\overline{C}_{Dn}$ or $\overline{S}_{Dn}$ to CP	2.0			3.0		2.0		ns	3-11

# 54F/74F86

## Quad 2-Input Exclusive-OR Gate

### Connection Diagram



Ordering Code: See Section 6

Pkgs	Commercial Grade	Military Grade	Pkg Type
	$V_{CC} = +5.0\text{ V} \pm 5\%$ , $T_A = 0^\circ\text{C to } +70^\circ\text{C}$	$V_{CC} = +5.0\text{ V} \pm 10\%$ , $T_A = -55^\circ\text{C to } +125^\circ\text{C}$	
Plastic DIP (P)	74F86PC		9A
Ceramic DIP (D)	74F86DC	54F86DM	6A
Flatpak (F)		54F86FM	3I

Input Loading/Fan-Out: See Section 3 for U.L. definitions

Pin Names	Description	54F74F (U.L.) HIGH/LOW
Inputs		0.5/0.375
Outputs		25/12.5

DC Characteristics Over Operating Temperature Range (unless otherwise specified)

Symbol	Parameter	54/74LS			Units	Conditions	
		Min	Typ	Max		Inputs LOW Inputs HIGH	$V_{CC} = \text{Max}$
$I_{CC}$	Power Supply Current		15	23	mA		
			18	28			

AC Characteristics: See Section 3 for waveforms and load configurations

Symbol	Parameter	54F/74F			54/F		74F		Units	Fig. No.
		$T_A = +25^\circ\text{C}$ $V_{CC} = +5.0\text{ V}$ $C_L = 50\text{ pF}$			$T_A, V_{CC} = \text{Mil}$ $C_L = 50\text{ pF}$		$T_A, V_{CC} = \text{Com}$ $C_L = 50\text{ pF}$			
		Min	Typ	Max	Min	Max	Min	Max		
$t_{PLH}$	Propagation Delay	3.0	4.0	5.5	3.0	7.0	3.0	6.5	ns	3-1 3-4
$t_{PHL}$	(Other Input LOW)	3.0	4.2	5.5	3.0	7.0	3.0	6.5		
$t_{PLH}$	Propagation Delay	3.5	5.3	7.0	3.5	8.5	3.5	8.0	ns	3-1 3-3
$t_{PHL}$	(Other Input HIGH)	3.0	4.7	6.5	3.0	8.0	3.0	7.5		

■ Test limits in screened columns are preliminary.

# 54F/74F109

## Dual $\overline{JK}$ Positive Edge-Triggered Flip-Flop

### Description

The 'F109 consists of two high-speed, completely independent transition clocked  $\overline{JK}$  flip-flops. The clocking operation is independent of rise and fall times of the clock waveform. The  $\overline{JK}$  design allows operation as a D flip-flop (refer to 'F74 data sheet) by connecting the J and  $\overline{K}$  inputs together.

### Truth Table

INPUTS		OUTPUTS	
@ $t_n$		@ $t_{n+1}$	
J	$\overline{K}$	Q	$\overline{Q}$
L	H	No Change	
L	L	L	H
H	H	H	L
H	L	Toggles	

### Asynchronous Inputs:

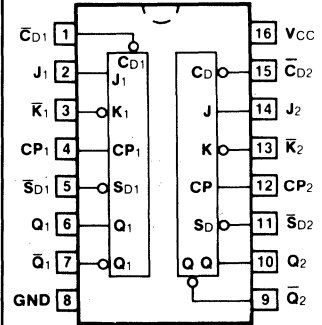
- LOW input to  $\overline{S}_D$  sets Q to HIGH level
- LOW input to  $\overline{C}_D$  sets Q to LOW level
- Clear and Set are independent of clock
- Simultaneous LOW on  $\overline{C}_D$  and  $\overline{S}_D$  makes both Q and  $\overline{Q}$  HIGH

$t_n$  = Bit time before clock pulse  
 $t_{n+1}$  = Bit time after clock pulse  
 H = HIGH Voltage Level  
 L = LOW Voltage Level

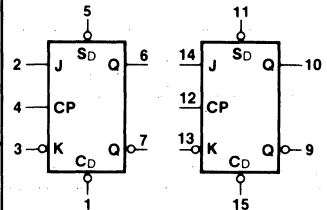
Ordering Code: See Section 6

	Commercial Grade	Military Grade	Pkg Type
Pkgs	$V_{CC} = +5.0\text{ V} \pm 5\%$ , $T_A = 0^\circ\text{C to } +70^\circ\text{C}$	$V_{CC} = +5.0\text{ V} \pm 10\%$ , $T_A = -55^\circ\text{C to } +125^\circ\text{C}$	
Plastic DIP (P)	74F109PC		9B
Ceramic DIP (D)	74F109DC	54F109DM	6B
Flatpak (F)		54F109FM	4L

### Connection Diagram



### Logic Symbol

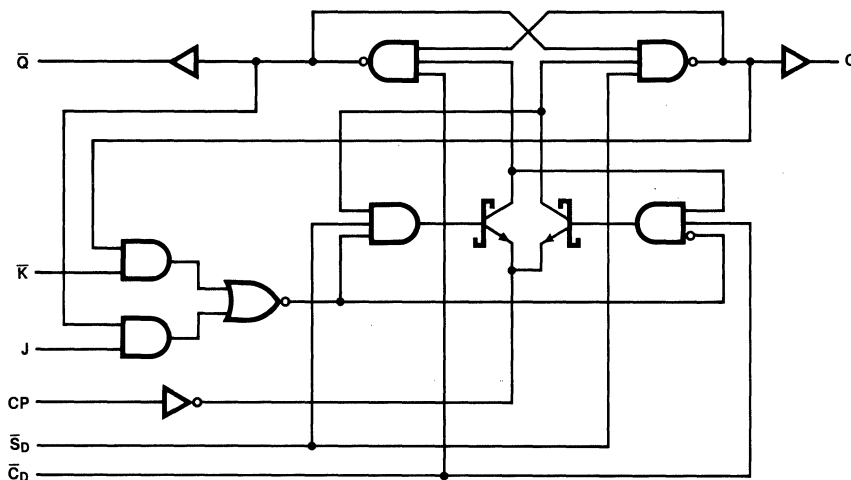


$V_{CC}$  = Pin 16  
 GND = Pin 8

Input Loading/Fan-Out: See Section 3 for U.L. definitions

Pin Names	Description	54F/74F (U.L.) HIGH/LOW
$J_1, J_2, \overline{K}_1, \overline{K}_2$	Data Inputs	0.5/0.375
$CP_1, CP_2$	Clock Pulse Inputs (Active Rising Edge)	0.5/0.375
$\overline{C}_D1, \overline{C}_D2$	Direct Clear Inputs (Active LOW)	0.5/1.125
$\overline{S}_D1, \overline{S}_D2$	Direct Set Inputs (Active LOW)	0.5/1.125
$Q_1, Q_2, \overline{Q}_1, \overline{Q}_2$	Outputs	25/12.5

## Logic Diagram (one half shown)



Please note that this diagram is provided only for the understanding of logic operations and should not be used to estimate propagation delays.

## DC Characteristics over Operating Temperature Range (unless otherwise specified)

Symbol	Parameter	54F/74F			Units	Conditions
		Min	Typ	Max		
$I_{CC}$	Power Supply Current		11.7	17	mA	$V_{CC} = \text{Max}, V_{CP} = 0 \text{ V}$

## AC Characteristics: See Section 3 for waveforms and load configurations

Symbol	Parameter	54F/74F			54F		74F		Units	Fig. No.
		$T_A = +25^\circ \text{C}, V_{CC} = +5.0 \text{ V}, C_L = 50 \text{ pF}$			$T_A, V_{CC} = \text{Mil}, C_L = 50 \text{ pF}$		$T_A, V_{CC} = \text{Com}, C_L = 50 \text{ pF}$			
		Min	Typ	Max	Min	Max	Min	Max		
$f_{\text{max}}$	Maximum Clock Frequency	90	125		90		90	MHz	3-1, 3-7	
$t_{\text{PLH}}$	Propagation Delay	3.8	5.3	7.0	3.8	9.0	3.8	8.0	ns	3-1
$t_{\text{PHL}}$	$CP_n$ to $Q_n$ to $\overline{Q}_n$	4.4	6.2	8.0	4.4	10.5	4.4	9.2		
$t_{\text{PLH}}$	Propagation Delay	3.2	5.2	7.0	3.2	9.0	3.2	8.0	ns	3-1
$t_{\text{PHL}}$	$\overline{C}_{Dn}$ or $\overline{S}_{Dn}$ to $Q_n$ or $\overline{Q}_n$	3.5	7.0	9.0	3.5	11.5	3.5	10.5		

■ Test limits in screened columns are preliminary.

**AC Operating Requirements:** See Section 3 for waveforms

Symbol	Parameter	54F/74F			54F		74F		Units	Fig. No.
		T <sub>A</sub> = +25°C, V <sub>CC</sub> = +5.0 V			T <sub>A</sub> , V <sub>CC</sub> = Mil		T <sub>A</sub> , V <sub>CC</sub> = Com			
		Min	Typ	Max	Min	Max	Min	Max		
t <sub>s</sub> (H) t <sub>s</sub> (L)	Setup Time, HIGH or LOW J <sub>n</sub> or $\overline{K}_n$ to CP <sub>n</sub>	3.0			3.0		3.0		ns	3-5
t <sub>h</sub> (H) t <sub>h</sub> (L)	Hold Time, HIGH or LOW J <sub>n</sub> or $\overline{K}_n$ to CP <sub>n</sub>	1.0			1.0		1.0			
t <sub>w</sub> (H) t <sub>w</sub> (L)	CP <sub>n</sub> Pulse Width, HIGH or LOW	4.0			4.0		4.0			
t <sub>w</sub> (L)	$\overline{C}_{Dn}$ or $\overline{S}_{Dn}$ Pulse Width LOW	4.0			4.0		4.0		ns	3-9
t <sub>rec</sub>	Recovery Time $\overline{C}_{Dn}$ or $\overline{S}_{Dn}$ to CP	2.0			2.0		2.0		ns	3-11

■ Test limits in screened columns are preliminary.

# 54F/74F112

## Dual JK Negative Edge-Triggered Flip-Flop

### Description

The 'F112 contains two independent, high-speed JK flip-flops with Direct Set and Clear inputs. Synchronous state changes are initiated by the falling edge of the clock. Triggering occurs at a voltage level of the clock and is not directly related to the transition time. The J and K inputs can change when the clock is in either state without affecting the flip-flop, provided that they are in the desired state during the recommended setup and hold times relative to the falling edge of the clock. A LOW signal on  $\overline{S}_D$  or  $\overline{C}_D$  prevents clocking and forces Q or  $\overline{Q}$  HIGH, respectively. Simultaneous LOW signals on  $\overline{S}_D$  and  $\overline{C}_D$  force both Q and  $\overline{Q}$  HIGH.

### Truth Table

INPUTS		OUTPUT
@ $t_n$	@ $t_{n+1}$	
J	K	Q
L	L	$Q_n$
L	H	L
H	L	H
H	H	$\overline{Q}_n$

### Asynchronous Inputs:

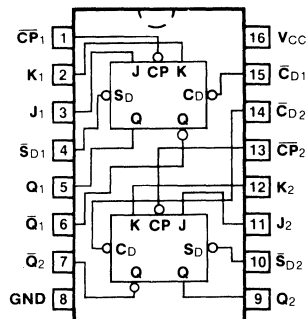
- LOW input to  $\overline{S}_D$  sets Q to HIGH level
- LOW input to  $\overline{C}_D$  sets Q to LOW level
- Clear and Set are independent of clock
- Simultaneous LOW on  $\overline{C}_D$  and  $\overline{S}_D$  makes both Q and  $\overline{Q}$  HIGH

$t_n$  = Bit time before clock pulse  
 $t_{n+1}$  = Bit time after clock pulse  
 H = HIGH Voltage Level  
 L = LOW Voltage Level

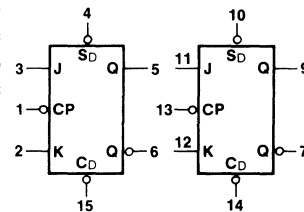
Ordering Code: See Section 6

Pkgs	Commercial Grade	Military Grade	Pkg Type
	$V_{CC} = +5.0 V \pm 5\%$ , $T_A = 0^\circ C$ to $+70^\circ C$	$V_{CC} = +5.0 V \pm 10\%$ , $T_A = -55^\circ C$ to $+125^\circ C$	
Plastic DIP (P)	74F112PC		9B
Ceramic DIP (D)	74F112DC	54F112DM	6B
Flatpak (F)		54F112FM	4L

### Connection Diagram



### Logic Symbol



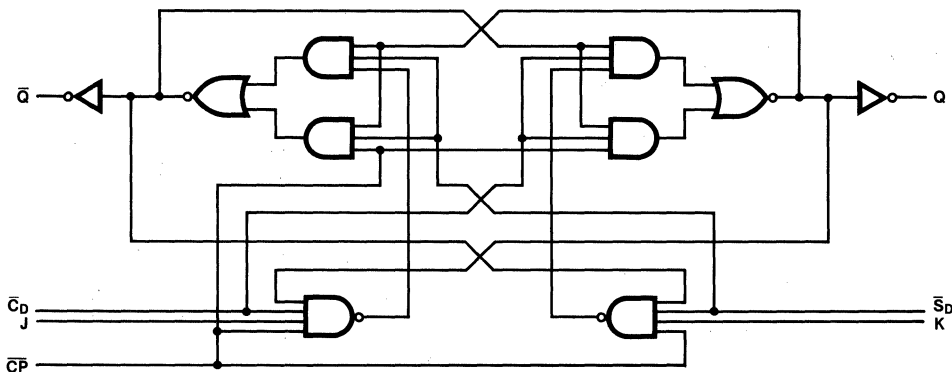
$V_{CC}$  = Pin 16  
 GND = Pin 8

Input Loading/Fan-Out: See Section 3 for U.L. definitions

Pin Names	Description	54F/74F (U.L.) HIGH/LOW
J <sub>1</sub> , J <sub>2</sub> , K <sub>1</sub> , K <sub>2</sub>	Data Inputs	0.5/0.375
$\overline{CP}_1$ , $\overline{CP}_2$	Clock Pulse Inputs (Active Falling Edge)	0.5/1.5
$\overline{CD}_1$ , $\overline{CD}_2$	Direct Clear Inputs (Active LOW)	0.5/1.875
$\overline{SD}_1$ , $\overline{SD}_2$	Direct Set Inputs (Active LOW)	0.5/1.875
Q <sub>1</sub> , Q <sub>2</sub> , $\overline{Q}_1$ , $\overline{Q}_2$	Outputs	25/12.5



Logic Diagram (one half shown)



Please note that this diagram is provided only for the understanding of logic operations and should not be used to estimate propagation delays.

DC Characteristics over Operating Temperature Range (unless otherwise specified)

Symbol	Parameter	54F/74F			Units	Conditions
		Min	Typ	Max		
I <sub>CC</sub>	Power Supply Current		12	19	mA	V <sub>CC</sub> = Max, V <sub>CP</sub> = 0

AC Characteristics: See Section 3 for waveforms and load configurations

Symbol	Parameter	54F/74F			54F		74F		Units	Fig. No.
		T <sub>A</sub> = +25°C, V <sub>CC</sub> = +5.0 V, C <sub>L</sub> = 50 pF			T <sub>A</sub> , V <sub>CC</sub> = Mil, C <sub>L</sub> = 50 pF		T <sub>A</sub> , V <sub>CC</sub> = Com, C <sub>L</sub> = 50 pF			
		Min	Typ	Max	Min	Max	Min	Max		
f <sub>max</sub>	Maximum Clock Frequency	100	125					MHz	3-1, 3-8	
t <sub>PLH</sub> t <sub>PHL</sub>	Propagation Delay CP <sub>n</sub> to Q <sub>n</sub> or Q̄ <sub>n</sub>	3.3	5.5	7.7				ns	3-1, 3-8	
t <sub>PLH</sub> t <sub>PHL</sub>	Propagation Delay C̄D <sub>n</sub> or S̄D <sub>n</sub> to Q <sub>n</sub> or Q̄ <sub>n</sub>	3.0	5.0	7.0				ns	3-1, 3-9	

■ Test limits in screened columns are preliminary.

## AC Operating Requirements: See Section 3 for waveforms

Symbol	Parameter	54F/74F			54F		74F		Units	Fig. No.
		T <sub>A</sub> = +25°C, V <sub>CC</sub> = +5.0 V			T <sub>A</sub> , V <sub>CC</sub> = Mil		T <sub>A</sub> , V <sub>CC</sub> = Com			
		Min	Typ	Max	Min	Max	Min	Max		
t <sub>s</sub> (H) t <sub>s</sub> (L)	Setup Time J <sub>n</sub> or K <sub>n</sub> to $\overline{CP}_n$	3.0							ns	3-6
t <sub>h</sub> (H) t <sub>h</sub> (L)	Hold Time J <sub>n</sub> or K <sub>n</sub> to $\overline{CP}_n$	0								
t <sub>w</sub> (H) t <sub>w</sub> (L)	$\overline{CP}_n$ Pulse Width	5.0							ns	3-8
t <sub>w</sub> (L)	$\overline{CD}_n$ or $\overline{SD}_n$ Pulse Width LOW	5.0							ns	3-9

■ Test limits in screened columns are preliminary.

# 54F/74F113

## Dual JK Edge-Triggered Flip-Flop

### Description

The 'F113 offers individual J, K, Set and Clock inputs. When the clock goes HIGH the inputs are enabled and data may be entered. The logic level of the J and K inputs may be changed when the clock pulse is HIGH and the bistable will perform according to the Truth Table as long as minimum setup and hold times are observed. Input data is transferred to the outputs on the falling edge of the clock pulse.

### Truth Table

INPUTS		OUTPUT
@ $t_n$		@ $t_{n+1}$
J	K	Q
L	L	$Q_n$
L	H	L
H	L	H
H	H	$\overline{Q}_n$

### Asynchronous Input:

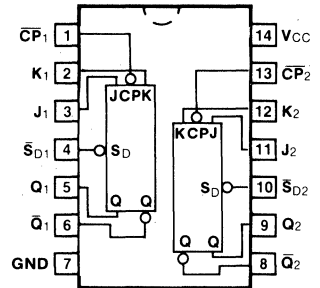
LOW input to  $\overline{S}_D$  sets Q to HIGH level  
Set is independent of clock

$t_n$  = Bit time before clock pulse  
 $t_{n+1}$  = Bit time after clock pulse  
H = HIGH Voltage Level  
L = LOW Voltage Level

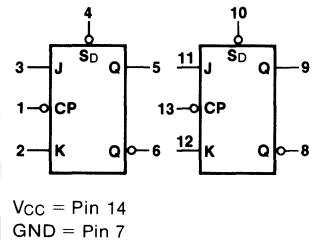
Ordering Code: See Section 6

Pkgs	Commercial Grade	Military Grade	Pkg Type
	$V_{CC} = +5.0\text{ V} \pm 5\%$ , $T_A = 0^\circ\text{ C to } +70^\circ\text{ C}$	$V_{CC} = +5.0\text{ V} \pm 10\%$ , $T_A = -55^\circ\text{ C to } +125^\circ\text{ C}$	
Plastic DIP (P)	74F113PC		9A
Ceramic DIP (D)	74F113DC	54F113DM	6A
Flatpak (F)		54F113FM	3I

### Connection Diagram



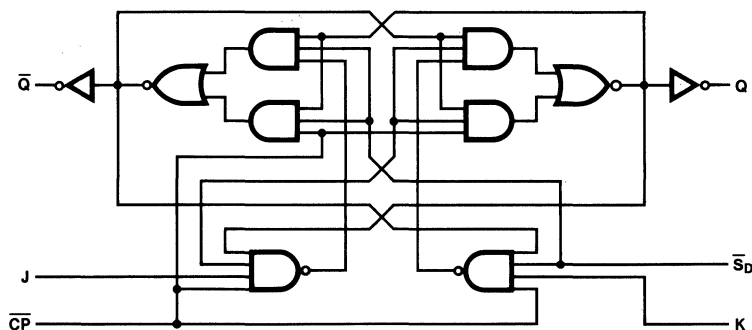
### Logic Symbol



Input Loading/Fan-Out: See Section 3 for U.L. definitions

Pin Names	Description	54F/74F (U.L.) HIGH/LOW
$J_1, J_2, K_1, K_2$	Data Inputs	0.5/0.375
$CP_1, CP_2$	Clock Pulse Inputs (Active Falling Edge)	0.5/1.50
$\overline{S}_{D1}, \overline{S}_{D2}$	Direct Set Inputs (Active LOW)	0.5/1.875
$Q_1, Q_2, \overline{Q}_1, \overline{Q}_2$	Outputs	25/12.5

Logic Diagram (one half shown)



Please note that this diagram is provided only for the understanding of logic operations and should not be used to estimate propagation delays.

#### DC Characteristics over Operating Temperature Range (unless otherwise specified)

Symbol	Parameter	54F/74F			Units	Conditions
		Min	Typ	Max		
$I_{CC}$	Power Supply Current		12	19	mA	$V_{CC} = \text{Max}, V_{CP} = 0V$

#### AC Characteristics: See Section 3 for waveforms and load configurations

Symbol	Parameter	54F/74F			54F		74F		Units	Fig. No.
		$T_A = +25^\circ C, V_{CC} = +5.0 V, C_L = 50 pF$			$T_A, V_{CC} = \text{Mil}, C_L = 50 pF$		$T_A, V_{CC} = \text{Com}, C_L = 50 pF$			
		Min	Typ	Max	Min	Max	Min	Max		
$f_{max}$	Maximum Clock Frequency	100	125					MHz	3-1, 3-8	
$t_{PLH}$	Propagation Delay	3.3	5.5	7.7				ns	3-1 3-8	
$t_{PHL}$	$\overline{CP}_n$ to $Q_n$ or $\overline{Q}_n$	3.3	5.5	7.7						
$t_{PLH}$	Propagation Delay	3.0	5.0	7.0				ns	3-1 3-9	
$t_{PHL}$	$\overline{SD}_N$ to $Q_n$ or $\overline{Q}_n$	3.3	5.5	7.7						

■ Test limits in screened columns are preliminary.

AC Operating Requirements: See Section 3 for waveforms

Symbol	Parameter	54F/74F			54F		74F		Units	Fig. No.
		T <sub>A</sub> = +25°C, V <sub>CC</sub> = +5.0 V			T <sub>A</sub> , V <sub>CC</sub> = Mil		T <sub>A</sub> , V <sub>CC</sub> = Com			
		Min	Typ	Max	Min	Max	Min	Max		
t <sub>s</sub> (H)	Setup Time	3.0						ns	3-6	
t <sub>s</sub> (L)	J <sub>n</sub> or K <sub>n</sub> to $\overline{CP}_n$	3.0								
t <sub>h</sub> (H)	Hold Time	0						ns	3-6	
t <sub>h</sub> (L)	J <sub>n</sub> or K <sub>n</sub> to $\overline{CP}_n$	0								
t <sub>w</sub> (H)	$\overline{CP}_n$ Pulse Width	5.0						ns	3-8	
t <sub>w</sub> (L)		5.0								
t <sub>w</sub> (L)	$\overline{SDN}$ Pulse Width LOW	5.0						ns	3-9	

■ Test limits in screened columns are preliminary.

# 54F/74F114

## Dual JK Negative Edge-Triggered Flip-Flop (With Common Clocks and Clears)

### Description

The 'F114 contains two high-speed JK flip-flops with common clock and Clear inputs. Synchronous state changes are initiated by the falling edge of the clock. Triggering occurs at a voltage level of the clock and is not directly related to the transition time. The J and K inputs can change when the clock is in either state without affecting the flip-flop, provided that they are in the desired state during the recommended setup and hold times relative to the falling edge of the clock. A LOW signal on  $\overline{S}_D$  or  $\overline{C}_D$  prevents clocking and forces Q or  $\overline{Q}$  HIGH, respectively. Simultaneous LOW signals on  $\overline{S}_D$  and  $\overline{C}_D$  force both Q and  $\overline{Q}$  HIGH.

### Truth Table

INPUTS		OUTPUT
@ $t_n$		@ $t_n + 1$
J	K	Q
L	L	$Q_n$
L	H	L
H	L	H
H	H	$\overline{Q}_n$

### Asynchronous Inputs:

- LOW input to  $\overline{S}_D$  sets Q to HIGH level
- LOW input to  $\overline{C}_D$  sets Q to LOW level
- Clear and Set are independent of clock
- Simultaneous LOW on  $\overline{C}_D$  and  $\overline{S}_D$  makes both Q and  $\overline{Q}$  HIGH

H = HIGH Voltage Level

L = LOW Voltage Level

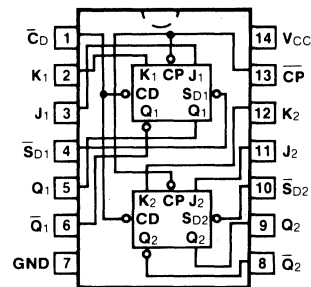
$t_n$  = Bit time before clock pulse

$t_n + 1$  = Bit time after clock pulse

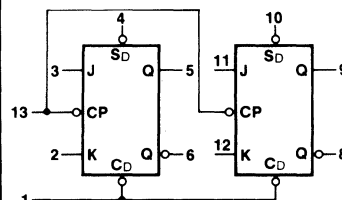
Ordering Code: See Section 6

Pkgs	Commercial Grade	Military Grade	Pkg Type
	$V_{CC} = +5.0 V \pm 5\%$ , $T_A = 0^\circ C$ to $+70^\circ C$	$V_{CC} = +5.0 V \pm 10\%$ , $T_A = -55^\circ C$ to $+125^\circ C$	
Plastic DIP (P)	74F114PC		9A
Ceramic DIP (D)	74F114DC	54F114DM	6A
Flatpak (F)		54F114FM	3I

### Connection Diagram



### Logic Symbol

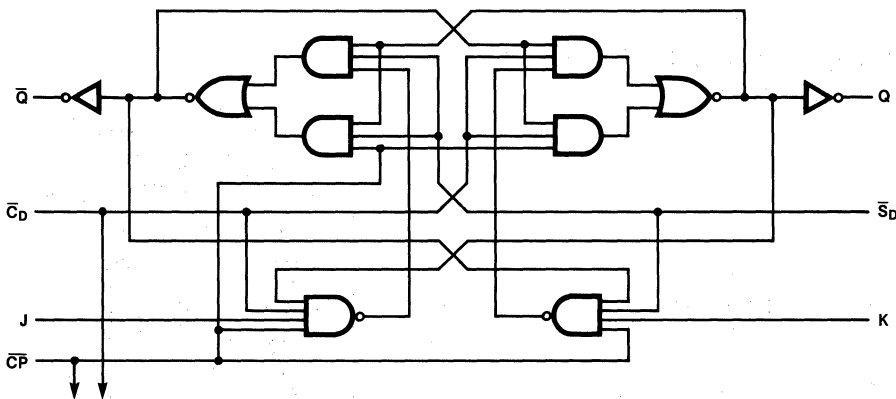


$V_{CC} = \text{Pin } 14$   
 $GND = \text{Pin } 7$

Input Loading/Fan-Out: See Section 3 for U.L. definitions

Pin Names	Description	54F/74F (U.L.) HIGH/LOW
$J_1, J_2, K_1, K_2$	Data Inputs	0.5/0.375
$\overline{CP}$	Clock Pulse Input (Active Falling Edge)	0.5/1.50
$\overline{C}_D$	Direct Clear Input (Active LOW)	0.5/1.875
$\overline{S}_D1, \overline{S}_D2$	Direct Set Inputs (Active LOW)	0.5/1.875
$Q_1, Q_2, \overline{Q}_1, \overline{Q}_2$	Outputs	25/12.5

Logic Diagram (one half shown)



Please note that this diagram is provided only for the understanding of logic operations and should not be used to estimate propagation delays.

DC Characteristics over Operating Temperature Range (unless otherwise specified)

Symbol	Parameter	54F/74F			Units	Conditions
		Min	Typ	Max		
I <sub>CC</sub>	Power Supply Current		12	19	mA	V <sub>CC</sub> = Max, V <sub>CP</sub> = 0

AC Characteristics: See Section 3 for waveforms and load configurations

Symbol	Parameter	54F/74F			54F		74F		Units	Fig. No.
		T <sub>A</sub> = +25°C, V <sub>CC</sub> = +5.0 V, C <sub>L</sub> = 50 pF			T <sub>A</sub> , V <sub>CC</sub> = Mil, C <sub>L</sub> = 50 pF		T <sub>A</sub> , V <sub>CC</sub> = Com, C <sub>L</sub> = 50 pF			
		Min	Typ	Max	Min	Max	Min	Max		
f <sub>max</sub>	Maximum Clock Frequency	100	125					MHz	3-1, 3-8	
t <sub>PLH</sub> t <sub>PHL</sub>	Propagation Delay C <sub>P</sub> to Q <sub>n</sub> or Q <sub>n</sub>	3.3	5.5	7.7				ns	3-1, 3-8	
t <sub>PLH</sub> t <sub>PHL</sub>	Propagation Delay C <sub>D</sub> or S <sub>Dn</sub> to Q <sub>n</sub> or Q <sub>n</sub>	3.0	5.0	7.0				ns	3-1, 3-9	

■ Test limits in screened columns are preliminary.

## AC Operating Requirements: See Section 3 for waveforms

Symbol	Parameter	54F/74F			54F		74F		Units	Fig. No.
		T <sub>A</sub> = +25°C, V <sub>CC</sub> = +5.0 V			T <sub>A</sub> , V <sub>CC</sub> = Mil		T <sub>A</sub> , V <sub>CC</sub> = Com			
		Min	Typ	Max	Min	Max	Min	Max		
t <sub>s</sub> (H) t <sub>s</sub> (L)	Setup Time J <sub>n</sub> or K <sub>n</sub> to $\overline{CP}$	3.0						ns	3-6	
t <sub>h</sub> (H) t <sub>h</sub> (L)	Hold Time J <sub>n</sub> or K <sub>n</sub> to $\overline{CP}$	0								
t <sub>w</sub> (H) t <sub>w</sub> (L)	$\overline{CP}$ Pulse Width	5.0						ns		3-8
t <sub>w</sub>	$\overline{CD}$ or $\overline{SD}_n$ Pulse Width	5.0						ns	3-9	

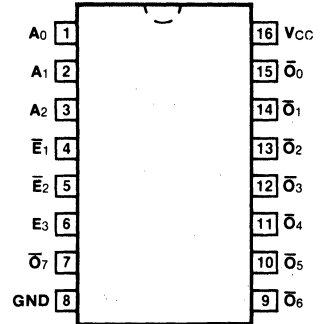
■ Test limits in screened columns are preliminary.



# 54F/74F138

1-of-8 Decoder/Demultiplexer

### Connection Diagram



### Description

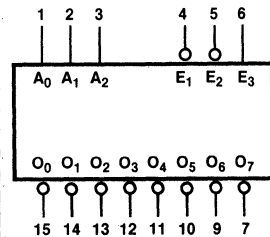
The 'F138 is a high-speed 1-of-8 decoder/demultiplexer. This device is ideally suited for high-speed bipolar memory chip select address decoding. The multiple input enables allow parallel expansion to a 1-of-24 decoder using just three 'F138 devices or a 1-of-32 decoder using four 'F138 devices and one inverter.

- **FAST Process for High Speed**
- **Demultiplexing Capability**
- **Multiple Input Enable for Easy Expansion**
- **Active-LOW Mutually Exclusive Outputs**

**Ordering Code:** See Section 6

Pkgs	Commercial Grade	Military Grade	Pkg Type
	$V_{CC} = +5.0 \text{ V} \pm 5\%$ , $T_A = 0^\circ \text{C to } +70^\circ \text{C}$	$V_{CC} = +5.0 \text{ V} \pm 10\%$ , $T_A = -55^\circ \text{C to } +125^\circ \text{C}$	
Plastic DIP (P)	74F138PC		9B
Ceramic DIP (D)	74F138DC	54F138DM	6B
Flatpak (F)		54F138FM	4L

### Logic Symbol



$V_{CC} = \text{Pin } 16$   
 $GND = \text{Pin } 8$

**Input Loading/Fan-Out:** See Section 3 for U.L. definitions

Pin Names	Description	54F/74F (U.L.) HIGH/LOW
$A_0 - A_2$	Address Inputs	0.5/0.375
$\bar{E}_1, \bar{E}_2$	Enable Inputs (Active LOW)	0.5/0.375
$E_3$	Enable Input (Active HIGH)	0.5/0.375
$\bar{O}_0 - \bar{O}_7$	Outputs (Active LOW)	25/12.5

### Functional Description

The 'F138 high-speed 1-of-8 decoder/multiplexer fabricated with the FAST process. The decoder accepts three binary weighted inputs ( $A_0, A_1, A_2$ ) and, when enabled, provides eight mutually exclusive active-LOW outputs ( $\bar{O}_0 - \bar{O}_7$ ). The 'F138 features three Enable inputs, two active LOW ( $\bar{E}_1, \bar{E}_2$ ) and one active HIGH ( $E_3$ ). All outputs will be HIGH unless  $\bar{E}_1$  and  $\bar{E}_2$  are LOW and  $E_3$  is HIGH. This multiple enable

function allows easy parallel expansion of the device to a 1-of-32 (5 lines to 32 lines) decoder with just four 'F138 devices and one inverter (See Figure a). The 'F138 can be used as an 8-output demultiplexer by using one of the active-LOW Enable inputs as the data input and the other Enable inputs as strobes. The Enable inputs which are not used must be permanently tied to their appropriate active-HIGH or active-LOW state.

### Truth Table

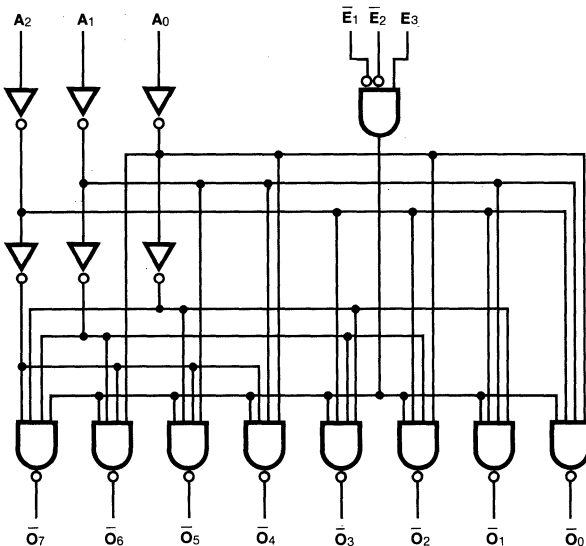
INPUTS						OUTPUTS							
$\bar{E}_1$	$\bar{E}_2$	$E_3$	$A_0$	$A_1$	$A_2$	$\bar{O}_0$	$\bar{O}_1$	$\bar{O}_2$	$\bar{O}_3$	$\bar{O}_4$	$\bar{O}_5$	$\bar{O}_6$	$\bar{O}_7$
H	X	X	X	X	X	H	H	H	H	H	H	H	H
X	H	X	X	X	X	H	H	H	H	H	H	H	H
X	X	L	X	X	X	H	H	H	H	H	H	H	H
L	L	H	L	L	L	L	H	H	H	H	H	H	H
L	L	H	H	L	L	H	L	H	H	H	H	H	H
L	L	H	L	H	L	H	H	L	H	H	H	H	H
L	L	H	H	H	L	H	H	H	L	H	H	H	H
L	L	H	L	L	H	H	H	H	H	L	H	H	H
L	L	H	H	L	H	H	H	H	H	H	L	H	H
L	L	H	L	H	H	H	H	H	H	H	H	L	H
L	L	H	H	H	H	H	H	H	H	H	H	H	L

H = HIGH Voltage Level

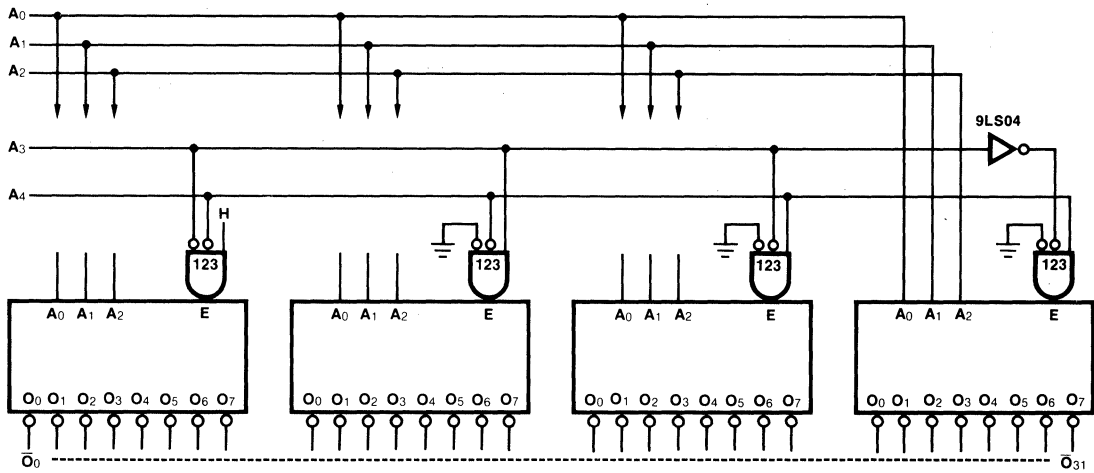
L = LOW Voltage Level

X = Immaterial

### Logic Diagram



**Fig. a Expansion to 1-of-32 Decoding**



**DC Characteristics over Operating Temperature Range** (unless otherwise specified)

Symbol	Parameter	54F/74F			Units	Conditions
		Min	Typ	Max		
I <sub>CC</sub>	Power Supply Current		13	20	mA	V <sub>CC</sub> = Max

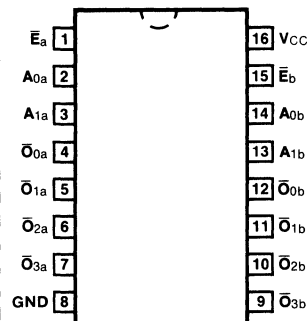
**AC Characteristics:** See Section 3 for waveforms and load configurations

Symbol	Parameter	54F/74F			54F		74F		Units	Fig. No.
		T <sub>A</sub> = +25°C, V <sub>CC</sub> = +5.0 V, C <sub>L</sub> = 50 pF			T <sub>A</sub> , V <sub>CC</sub> = Mil, C <sub>L</sub> = 50 pF		T <sub>A</sub> , V <sub>CC</sub> = Com, C <sub>L</sub> = 50 pF			
		Min	Typ	Max	Min	Max	Min	Max		
t <sub>PLH</sub> t <sub>PHL</sub>	Propagation Delay A <sub>n</sub> to $\overline{O}_n$	3.5 4.0	5.6 6.1	7.0 8.0	3.5 4.0	12 9.5	3.5 4.0	8.0 9.0	ns	3-1, 3-10
t <sub>PLH</sub> t <sub>PHL</sub>	Propagation Delay $\overline{E}_1$ or $\overline{E}_2$ to $\overline{O}_n$	3.5 3.0	5.4 5.3	7.0 7.0	3.5 3.0	11 8.0	3.5 3.0	8.0 7.5	ns	3-1, 3-4
t <sub>PLH</sub> t <sub>PHL</sub>	Propagation Delay E <sub>3</sub> to $\overline{O}_n$	4.0 3.5	6.2 5.6	8.0 7.5	4.0 3.5	12.5 8.5	4.0 3.5	9.0 8.5	ns	3-1, 3-3

# 54F/74F139

## Dual 1-of-4 Decoder

### Connection Diagram



### Description

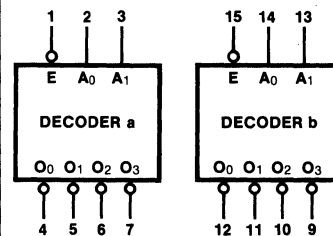
The 'F139 is a high-speed, dual 1-of-4 decoder/demultiplexer. The device has two independent decoders, each accepting two inputs and providing four mutually exclusive active-LOW outputs. Each decoder has an active-LOW Enable input which can be used as a data input for a 4-output demultiplexer. Each half of the 'F139 can be used as a function generator providing all four minterms of two variables.

- Multifunction Capability
- Two Completely Independent 1-of-4 Decoders
- Active LOW Mutually Exclusive Outputs

**Ordering Code:** See Section 6

Pkgs	Commercial Grade	Military Grade	Pkg Type
	$V_{CC} = +5.0\text{ V} \pm 5\%$ , $T_A = 0^\circ\text{C to } +70^\circ\text{C}$	$V_{CC} = +5.0\text{ V} \pm 10\%$ , $T_A = -55^\circ\text{C to } +125^\circ\text{C}$	
Plastic DIP (P)	74F139PC		9B
Ceramic DIP (D)	74F139DC	54F139DM	6B
Flatpak (F)		54F139FM	4L

### Logic Symbol



$V_{CC} = \text{Pin } 16$   
 $GND = \text{Pin } 8$

**Input Loading/Fan-Out:** See Section 3 for U.L. definitions

Pin Names	Description	54F/74F (U.L.) HIGH/LOW
$A_0, A_1$	Address Inputs	0.5/0.375
$\bar{E}$	Enable Inputs (Active LOW)	0.5/0.375
$\bar{O}_0 - \bar{O}_3$	Outputs (Active LOW)	25/12.5

**Functional Description**

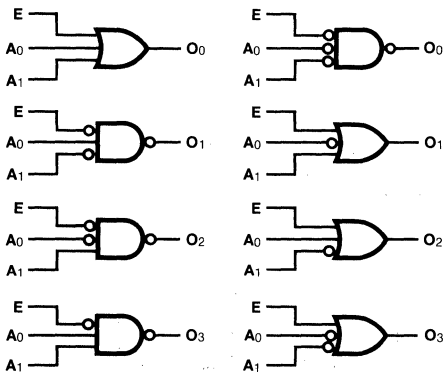
The 'F139 is a high-speed dual 1-of-4 decoder/demultiplexer. The device has two independent decoders, each of which accepts two binary weighed inputs ( $A_0, A_1$ ) and provides four mutually exclusive active-LOW outputs ( $\bar{O}_0 - \bar{O}_3$ ). Each decoder has an active LOW enable ( $\bar{E}$ ). When  $\bar{E}$  is HIGH all outputs are forced HIGH. The enable can be used as the data input for a 4-output demultiplexer application. Each half of the 'F139 generates all four minterms of two variables. These four minterms are useful in some applications, replacing multiple gate functions as shown in *Figure a*, and thereby reducing the number of packages required in a logic network.

**Truth Table**

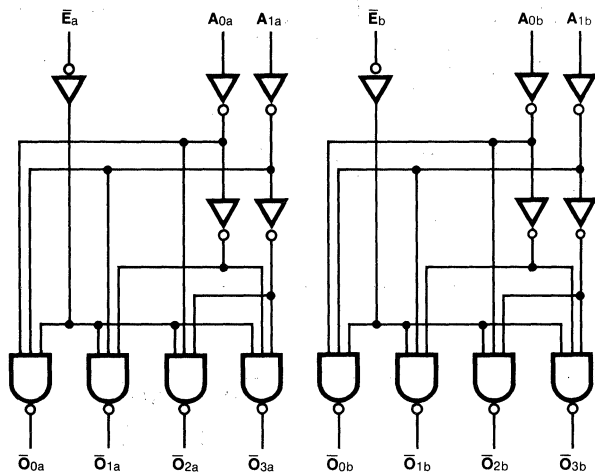
INPUTS			OUTPUTS			
$\bar{E}$	$A_0$	$A_1$	$\bar{O}_0$	$\bar{O}_1$	$\bar{O}_2$	$\bar{O}_3$
H	X	X	H	H	H	H
L	L	L	L	H	H	H
L	H	L	H	L	H	H
L	L	H	H	H	L	H
L	H	H	H	H	H	L

H = HIGH Voltage Level  
 L = LOW Voltage Level  
 X = Immaterial

**Fig. a Gate Functions (each half)**



**Logic Diagram**



**DC Characteristics over Operating Temperature Range** (unless otherwise specified)

Symbol	Parameter	54F/74F			Units	Conditions
		Min	Typ	Max		
I <sub>CC</sub>	Power Supply Current		13	20	mA	V <sub>CC</sub> = Max

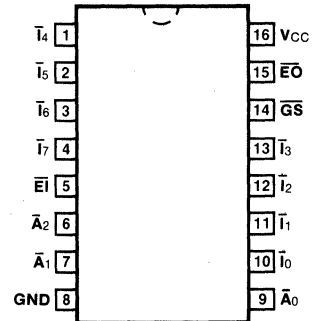
**AC Characteristics:** See Section 3 for waveforms and load configurations

Symbol	Parameter	54F/74F			54F		74F		Units	Fig. No.
		T <sub>A</sub> = +25°C, V <sub>CC</sub> = +5.0 V C <sub>L</sub> = 50 pF			T <sub>A</sub> , V <sub>CC</sub> = Mil C <sub>L</sub> = 50 pF		T <sub>A</sub> , V <sub>CC</sub> = Com C <sub>L</sub> = 50 pF			
		Min	Typ	Max	Min	Max	Min	Max		
t <sub>PLH</sub> t <sub>PHL</sub>	Propagation Delay A <sub>0</sub> or A <sub>1</sub> to $\overline{O}_n$	3.5 4.0	5.3 6.1	7.0 8.0	2.5 3.5	9.5 9.5	3.0 4.0	8.0 9.0	ns	3-1, 3-10
t <sub>PLH</sub> t <sub>PHL</sub>	Propagation Delay $\overline{E}_1$ to $\overline{O}_n$	3.5 3.0	5.4 4.7	7.0 6.5	3.0 2.5	9.0 8.0	3.5 3.0	8.0 7.5	ns	3-1, 3-4

## 54F/74F148

## 8-Line to 3-Line Priority Encoder

## Connection Diagram



## Description

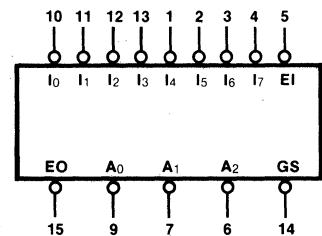
The 'F148 provides three bits of binary coded output representing the position of the highest order active input, along with an output indicating the presence of any active input. It is easily expanded via input and output enables to provide priority encoding over many bits.

- Encodes Eight Data Lines in Priority
- Provides 3-Bit Binary Priority Code
- Input Enable Capability
- Signals When Data Present on Any Input
- Cascadable for Priority Encoding of n Bits

Ordering Code: See Section 6

Pkgs	Commercial Grade	Military Grade	Pkg Type
	VCC = +5.0 V $\pm$ 5%, TA = 0°C to +70°C	VCC = +5.0 V $\pm$ 10%, TA = -55°C to +125°C	
Plastic DIP (P)	74F148PC		9B
Ceramic DIP (D)	74F148DC	54F148DM	6B
Flatpak (F)		54F148FM	4L

## Logic Symbol



VCC = Pin 16  
GND = Pin 8

Input Loading/Fan-Out: See Section 3 for U.L. definitions

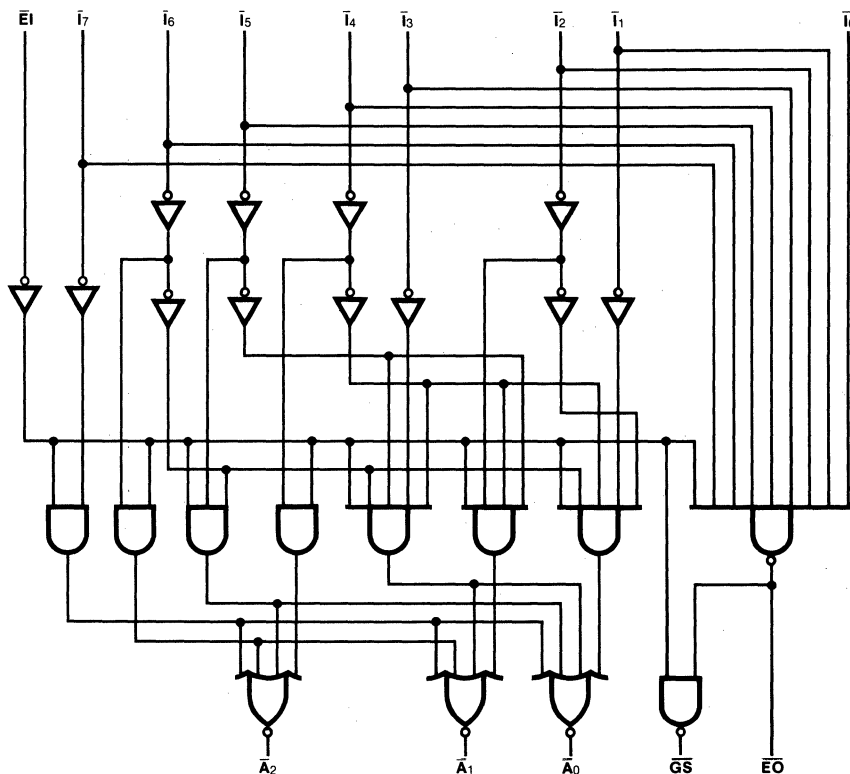
Pin Names	Description	54F/74F (U.L.) HIGH/LOW
$\overline{I_0} - \overline{I_7}$	Priority Inputs (Active LOW)	0.5/0.375
$\overline{EI}$	Enable Input (Active LOW)	0.5/0.375
$\overline{EO}$	Enable Output (Active LOW)	25/12.5
$\overline{GS}$	Group Select Output (Active LOW)	25/12.5
$\overline{A_0} - \overline{A_2}$	Address Outputs (Active LOW)	25/12.5

### Functional Description

The 'F148 8-input priority encoder accepts data from eight active-LOW inputs ( $\overline{I_0}$ – $\overline{I_7}$ ) and provides a binary representation on the three active-LOW outputs. A priority is assigned to each input so that when two or more inputs are simultaneously active, the input with the highest priority is represented on the output, with input line 7 having the highest priority. A HIGH on the Enable Input ( $\overline{EI}$ ) will force all outputs to the inactive (HIGH) state and allow new data to settle without producing erroneous information at the outputs. A Group Signal output ( $\overline{GS}$ ) and Enable Output ( $\overline{EO}$ ) are provided along with the three priority data outputs ( $\overline{A_2}$ ,  $\overline{A_1}$ ,  $\overline{A_0}$ ).  $\overline{GS}$  is active LOW when any input is LOW; this indicates when any input is active.  $\overline{EO}$  is active LOW when all inputs are HIGH. Using the Enable Output along with the Enable Input allows cascading for priority encoding on any number of input signals. Both  $\overline{EO}$  and  $\overline{GS}$  are in the inactive HIGH state when the Enable Input is HIGH.

4

### Logic Diagram





Truth Table

INPUTS									OUTPUTS				
EI	T <sub>0</sub>	T <sub>1</sub>	T <sub>2</sub>	T <sub>3</sub>	T <sub>4</sub>	T <sub>5</sub>	T <sub>6</sub>	T <sub>7</sub>	GS	A <sub>0</sub>	A <sub>1</sub>	A <sub>2</sub>	EO
H	X	X	X	X	X	X	X	X	H	H	H	H	H
L	H	H	H	H	H	H	H	H	H	H	H	H	L
L	X	X	X	X	X	X	X	L	L	L	L	L	H
L	X	X	X	X	X	X	L	H	L	H	L	L	H
L	X	X	X	X	X	L	H	H	L	L	H	L	H
L	X	X	X	L	H	H	H	H	L	L	L	H	H
L	X	X	L	H	H	H	H	H	L	H	L	H	H
L	X	L	H	H	H	H	H	H	L	L	H	H	H
L	L	H	H	H	H	H	H	H	L	H	H	H	H

H = HIGH Voltage Level  
L = LOW Voltage Level  
X = Immaterial

DC Characteristics over Operating Temperature Range (unless otherwise specified)

Symbol	Parameter	54F/74F			Units	Conditions
		Min	Typ	Max		
I <sub>CC</sub>	Power Supply Current		23	35	mA	V <sub>CC</sub> = Max

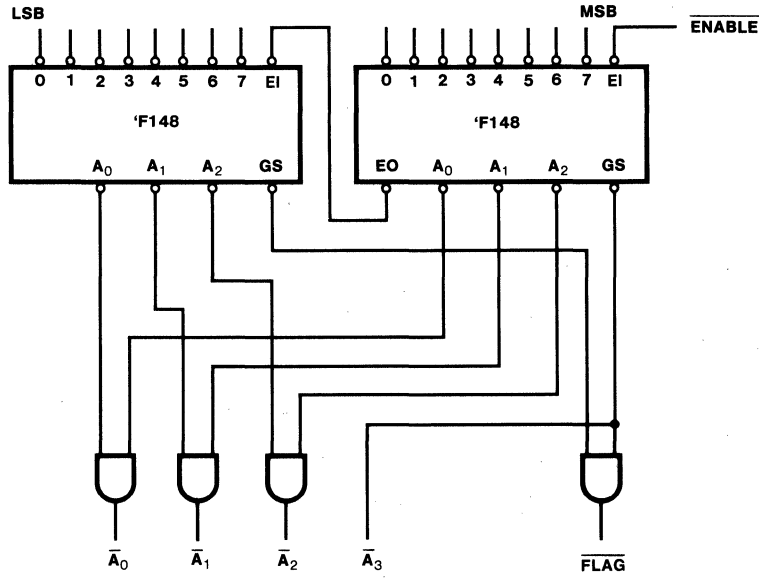
AC Characteristics: See Section 3 for waveforms and load configurations

Symbol	Parameter	54F/74F			54F		74F		Units	Fig. No.
		T <sub>A</sub> = +25°C, V <sub>CC</sub> = +5.0 V C <sub>L</sub> = 50 pF			T <sub>A</sub> , V <sub>CC</sub> = Mil C <sub>L</sub> = 50 pF		T <sub>A</sub> , V <sub>CC</sub> = Com. C <sub>L</sub> = 50 pF			
		Min	Typ	Max	Min	Max	Min	Max		
t <sub>PLH</sub> t <sub>PHL</sub>	Propagation Delay T <sub>n</sub> to A <sub>n</sub>	3.0 3.0	7.0 7.0	10.5 10.5				ns	3-1, 3-10	
t <sub>PLH</sub> t <sub>PHL</sub>	Propagation Delay T <sub>n</sub> to EO	2.5 2.0	3.5 3.5	5.0 4.5				ns	3-1, 3-3	
t <sub>PLH</sub> t <sub>PHL</sub>	Propagation Delay T <sub>n</sub> to GS	3.0 3.0	5.0 5.0	7.0 7.0				ns	3-1, 3-4	
t <sub>PLH</sub> t <sub>PHL</sub>	Propagation Delay EI to A <sub>n</sub>	3.5 3.5	6.0 6.0	8.5 8.5				ns	3-1, 3-4	
t <sub>PLH</sub> t <sub>PHL</sub>	Propagation Delay EI to GS	3.0 3.0	5.0 5.0	7.0 7.0				ns	3-1, 3-4	
t <sub>PLH</sub> t <sub>PHL</sub>	Propagation Delay EI to EO	2.0 2.0	5.0 5.0	7.0 7.0				ns	3-1, 3-4	

■ Test limits in screened columns are preliminary.

Application

16-Input Priority Encoder

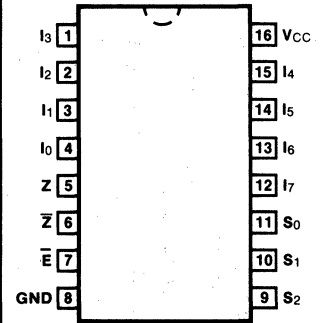


4

# 54F/74F151

## 8-Input Multiplexer

### Connection Diagram



### Description

The 'F151 is a high-speed 8-input digital multiplexer. It provides in one package, the ability to select one line of data from up to eight sources. The 'F151 can be used as a universal function generator to generate any logic function of four variables. Both assertion and negation outputs are provided.

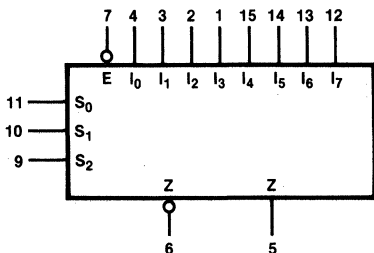
**Ordering Code:** See Section 6

Pkgs	Commercial Grade	Military Grade	Pkg Type
	$V_{CC} = +5.0\text{ V} \pm 5\%$ , $T_A = 0^\circ\text{ C to } +70^\circ\text{ C}$	$V_{CC} = +5.0\text{ V} \pm 10\%$ , $T_A = -55^\circ\text{ C to } +125^\circ\text{ C}$	
Plastic DIP (P)	74F151PC		9B
Ceramic DIP (D)	74F151DC	54F151DM	6B
Flatpak (F)		54F151FM	4L

**Input Loading/Fan-Out:** See Section 3 for U.L. definitions

Pin Names	Description	54F/74F (U.L.) HIGH/LOW
I <sub>0</sub> - I <sub>7</sub>	Data Inputs	0.5/0.375
S <sub>0</sub> - S <sub>2</sub>	Select Inputs	0.5/0.375
$\bar{E}$	Enable Input (Active LOW)	0.5/0.375
Z	Data Output	25/12.5
$\bar{Z}$	Inverted Data Output	25/12.5

### Logic Symbol



$V_{CC}$  = Pin 16  
GND = Pin 8

**Functional Description**

The 'F151 is a logic implementation of a single pole, 8-position switch with the switch position controlled by the state of three Select inputs,  $S_0, S_1, S_2$ . Both assertion and negation outputs are provided. The Enable input ( $\bar{E}$ ) is active LOW. When it is not activated, the negation output is HIGH and the assertion output is LOW regardless of all other inputs. The logic function provided at the output is:

$$Z = \bar{E} \cdot (I_0 \cdot \bar{S}_0 \cdot \bar{S}_1 \cdot \bar{S}_2 + I_1 \cdot S_0 \cdot \bar{S}_1 \cdot \bar{S}_2 + I_2 \cdot \bar{S}_0 \cdot S_1 \cdot \bar{S}_2 + I_3 \cdot S_0 \cdot S_1 \cdot \bar{S}_2 + I_4 \cdot \bar{S}_0 \cdot \bar{S}_1 \cdot S_2 + I_5 \cdot S_0 \cdot \bar{S}_1 \cdot S_2 + I_6 \cdot \bar{S}_0 \cdot S_1 \cdot S_2 + I_7 \cdot S_0 \cdot S_1 \cdot S_2)$$

The 'F151 provides the ability, in one package, to select from eight sources of data or control information. By proper manipulation of the inputs, the 'F151 can provide any logic function of four variables and its negation.

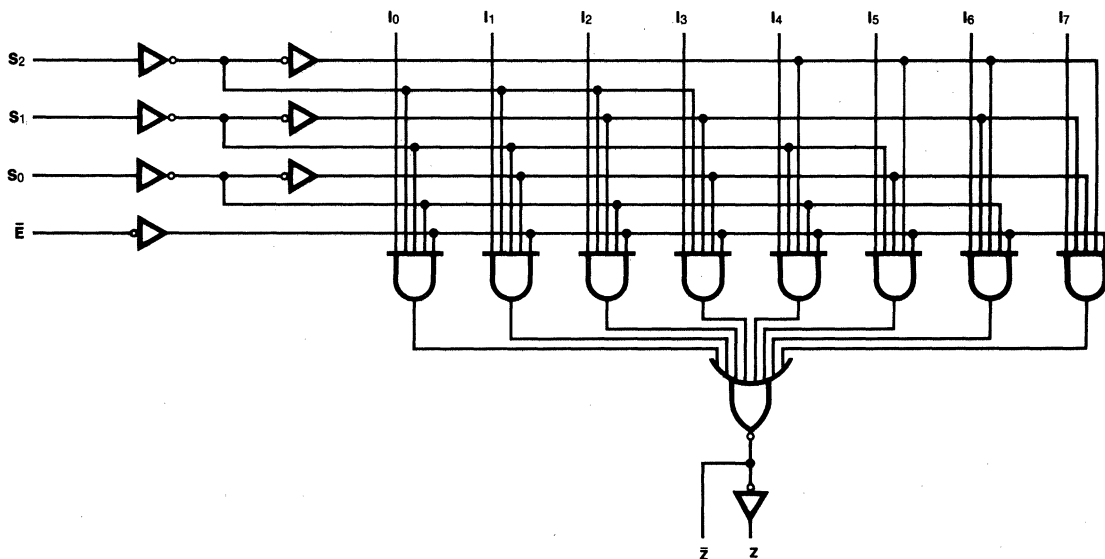
**Truth Table**

INPUTS				OUTPUTS	
$\bar{E}$	$S_2$	$S_1$	$S_0$	$\bar{Z}$	Z
H	X	X	X	H	L
L	L	L	L	$\bar{I}_0$	$I_0$
L	L	L	H	$\bar{I}_1$	$I_1$
L	L	H	L	$\bar{I}_2$	$I_2$
L	L	H	H	$\bar{I}_3$	$I_3$
L	H	L	L	$\bar{I}_4$	$I_4$
L	H	L	H	$\bar{I}_5$	$I_5$
L	H	H	L	$\bar{I}_6$	$I_6$
L	H	H	H	$\bar{I}_7$	$I_7$

H = HIGH Voltage Level  
 L = LOW Voltage Level  
 X = Immaterial

4

**Logic Diagram**



**DC Characteristics over Operating Temperature Range** (unless otherwise specified)

Symbol	Parameter	54F/74F			Units	Conditions
		Min	Typ	Max		
I <sub>CC</sub>	Power Supply Current		13.5	21	mA	V <sub>CC</sub> = Max, V <sub>IN</sub> = 4.5 V

**AC Characteristics:** See Section 3 for waveforms and load configurations

Symbol	Parameter	54F/74F			54F		74F		Units	Fig. No.
		T <sub>A</sub> = +25°C, V <sub>CC</sub> = +5.0 V, C <sub>L</sub> = 50 pF			T <sub>A</sub> , V <sub>CC</sub> = Mil, C <sub>L</sub> = 50 pF		T <sub>A</sub> , V <sub>CC</sub> = Com, C <sub>L</sub> = 50 pF			
		Min	Typ	Max	Min	Max	Min	Max		
t <sub>PLH</sub> t <sub>PHL</sub>	Propagation Delay S <sub>n</sub> to $\bar{Z}$	4.5 3.2	6.2 5.6	8.0 6.1	4.0 3.0	10 8.0	4.5 3.2	9.0 7.0	ns	3-1 3-10
t <sub>PLH</sub> t <sub>PHL</sub>	Propagation Delay S <sub>n</sub> to Z	4.5 5.0	9.9 7.1	13 9.0	4.5 4.5	17.5 11.5	4.5 5.0	15 10.5	ns	3-1 3-10
t <sub>PLH</sub> t <sub>PHL</sub>	Propagation Delay $\bar{E}$ to $\bar{Z}$	3.4 4.5	4.8 6.8	6.1 8.5	3.4 4.0	7.5 10.5	3.4 4.5	7.0 10	ns	3-1 3-4
t <sub>PLH</sub> t <sub>PHL</sub>	Propagation Delay $\bar{E}$ to Z	5.0 3.8	7.3 5.4	9.5 7.0	4.5 3.5	14.5 9.5	5.0 3.8	11 8.0	ns	3-1 3-3
t <sub>PLH</sub> t <sub>PHL</sub>	Propagation Delay I <sub>n</sub> to $\bar{Z}$	3.0 2.0	4.3 2.9	5.7 4.0	2.5 1.5	7.5 6.0	3.0 2.0	6.5 5.0	ns	3-1 3-3
t <sub>PLH</sub> t <sub>PHL</sub>	Propagation Delay I <sub>n</sub> to Z	4.0 3.7	7.6 5.2	9.5 6.5	3.5 3.5	11 8.0	4.0 3.7	11 7.5	ns	3-1 3-4

# 54F/74F153

## Dual 4-Input Multiplexer

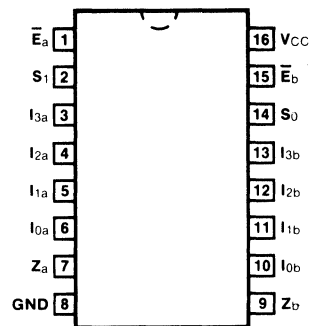
### Description

The 'F153 is a high-speed dual 4-input multiplexer with common select inputs and individual enable inputs for each section. It can select two lines of data from four sources. The two buffered outputs present data in the true (non-inverted) form. In addition to multiplexer operation, the 'F153 can generate any two functions of three variables.

**Ordering Code:** See Section 6

Pkgs	Commercial Grade	Military Grade	Pkg Type
	V <sub>CC</sub> = +5.0 V ±5%, T <sub>A</sub> = 0° C to +70° C	V <sub>CC</sub> = +5.0 V ±10%, T <sub>A</sub> = -55° C to +125° C	
Plastic DIP (P)	74F153PC		9B
Ceramic DIP (D)	74F153DC	54F153DM	6B
Flatpak (F)		54F153FM	4L

### Connection Diagram

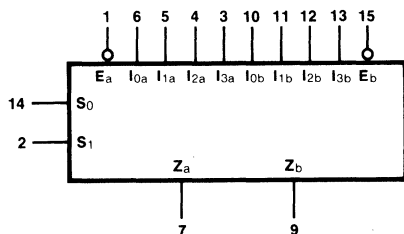


4

**Input Loading/Fan-Out:** See Section 3 for U.L. definitions

Pin Names	Description	54F/74F (U.L.) HIGH/LOW
I <sub>0a</sub> - I <sub>3a</sub>	Side A Data Inputs	0.5/0.375
I <sub>0b</sub> - I <sub>3b</sub>	Side B Data Inputs	0.5/0.375
S <sub>0</sub> , S <sub>1</sub>	Common Select Inputs	0.5/0.375
$\bar{E}_a$	Side A Enable Input (Active LOW)	0.5/0.375
$\bar{E}_b$	Side B Enable Input (Active LOW)	0.5/0.375
Z <sub>a</sub>	Side A Output	25/12.5
Z <sub>b</sub>	Side B Output	25/12.5

### Logic Symbol



V<sub>CC</sub> = Pin 16  
GND = Pin 8

## Functional Description

The 'F153 is a dual 4-input multiplexer. It can select two bits of data from up to four sources under the control of the common Select inputs ( $S_0, S_1$ ). The two 4-input multiplexer circuits have individual active-LOW Enables ( $\overline{E}_a, \overline{E}_b$ ) which can be used to strobe the outputs independently. When the Enables ( $\overline{E}_a, \overline{E}_b$ ) are HIGH, the corresponding outputs ( $Z_a, Z_b$ ) are forced LOW. The 'F153 is the logic implementation of a 2-pole, 4-position switch, where the position of the switch is determined by the logic levels supplied to the two Select inputs. The logic equations for the outputs are shown below.

$$Z_a = \overline{E}_a \cdot (I_{0a} \cdot \overline{S}_1 \cdot \overline{S}_0 + I_{1a} \cdot \overline{S}_1 \cdot S_0 + I_{2a} \cdot S_1 \cdot \overline{S}_0 + I_{3a} \cdot S_1 \cdot S_0)$$

$$Z_b = \overline{E}_b \cdot (I_{0b} \cdot \overline{S}_1 \cdot \overline{S}_0 + I_{1b} \cdot \overline{S}_1 \cdot S_0 + I_{2b} \cdot S_1 \cdot \overline{S}_0 + I_{3b} \cdot S_1 \cdot S_0)$$

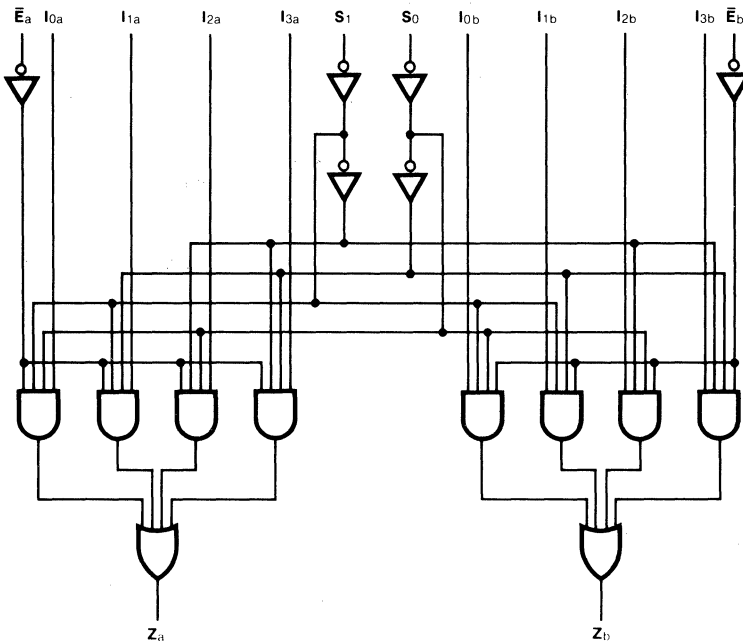
The 'F153 can be used to move data from a group of registers to a common output bus. The particular register from which the data came would be determined by the state of the Select inputs. A less obvious application is as a function generator. The 'F153 can generate two functions of three variables. This is useful for implementing highly irregular random logic.

## Truth Table

SELECT INPUTS		$\overline{E}$	INPUTS (a or b)				OUTPUT
$S_0$	$S_1$		$I_0$	$I_1$	$I_2$	$I_3$	
X	X	H	X	X	X	X	L
L	L	L	L	X	X	X	L
L	L	L	H	X	X	X	H
H	L	L	X	L	X	X	L
H	L	L	X	H	X	X	H
L	H	L	X	X	L	X	L
L	H	L	X	X	H	X	H
H	H	L	X	X	X	L	L
H	H	L	X	X	X	H	H

H = HIGH Voltage Level  
 L = LOW Voltage Level  
 X = Immaterial

## Logic Diagram



**DC Characteristics over Operating Temperature Range** (unless otherwise specified)

Symbol	Description	54F/74F			Units	Conditions
		Min	Typ	Max		
I <sub>CC</sub>	Power Supply Current		12	20	mA	V <sub>CC</sub> = Max, V <sub>IN</sub> = Gnd

**AC Characteristics:** See Section 3 for waveforms and load configurations

Symbol	Parameter	54F/74F			54F		74F		Units	Fig. No.
		T <sub>A</sub> = +25°C, V <sub>CC</sub> = +5.0 V C <sub>L</sub> = 50 pF			T <sub>A</sub> , V <sub>CC</sub> = Mil C <sub>L</sub> = 50 pF		T <sub>A</sub> , V <sub>CC</sub> = Com C <sub>L</sub> = 50 pF			
		Min	Typ	Max	Min	Max	Min	Max		
t <sub>PLH</sub> t <sub>PHL</sub>	Propagation Delay S <sub>n</sub> to Z <sub>n</sub>	5.5 4.0	8.1 7.0	10.5 9.0	5.0 3.5	14 11	5.5 4.0	12 10.5	ns	3-1, 3-10
t <sub>PLH</sub> t <sub>PHL</sub>	Propagation Delay $\bar{E}_n$ to Z <sub>n</sub>	5.0 4.0	7.1 5.7	9.0 7.0	4.5 3.5	11.5 9.0	5.0 4.0	10.5 8.0	ns	3-1, 3-3
t <sub>PLH</sub> t <sub>PHL</sub>	Propagation Delay I <sub>n</sub> to Z <sub>n</sub>	4.0 3.0	5.3 5.1	7.0 6.5	3.5 2.5	9.0 8.0	4.0 3.0	8.0 7.5	ns	3-1, 3-4



# 54F/74F157

## Quad 2-Input Multiplexer

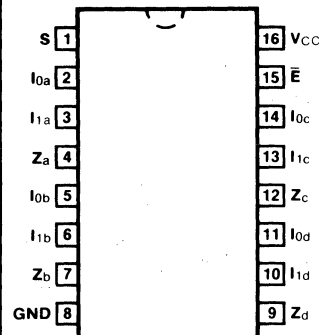
### Description

The 'F157 is a high-speed quad 2-input multiplexer. Four bits of data from two sources can be selected using the common Select and Enable inputs. The four buffered outputs present the selected data in the true (non-inverted) form. The 'F157 can also be used to generate any four of the 16 different functions to two variables.

**Ordering Code:** See Section 6

Pkgs	Commercial Grade	Military Grade	Pkg Type
	$V_{CC} = +5.0\text{ V} \pm 5\%$ , $T_A = 0^\circ\text{C to } +70^\circ\text{C}$	$V_{CC} = +5.0\text{ V} \pm 10\%$ , $T_A = -55^\circ\text{C to } +125^\circ\text{C}$	
Plastic DIP (P)	74F157PC		9B
Ceramic DIP (D)	74F157DC	54F157DM	6B
Flatpak (F)		54F157FM	4L

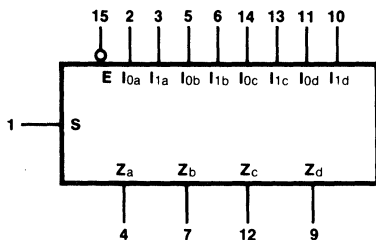
### Connection Diagram



**Input Loading/Fan-Out:** See Section 3 for U.L. definitions

Pin Names	Description	54F/74F (U.L.) HIGH/LOW
$I_{0a} - I_{0d}$	Source 0 Data Inputs	0.5/0.375
$I_{1a} - I_{1d}$	Source 1 Data Inputs	0.5/0.375
$\bar{E}$	Enable Input (Active LOW)	0.5/0.375
S	Select Input	0.5/0.375
$Z_a - Z_d$	Outputs	25/12.5

### Logic Symbol



$V_{CC}$  = Pin 16  
GND = Pin 8

### Functional Description

The 'F157 is a quad 2-input multiplexer. It selects four bits of data from two sources under the control of a common Select input (S). The Enable input ( $\bar{E}$ ) is active LOW. When  $\bar{E}$  is HIGH, all of the outputs (Z) are forced LOW regardless of all other inputs. The 'F157 is the logic implementation of a 4-pole, 2-position switch where the position of the switch is determined by the logic levels supplied to the Select input. The logic equations for the outputs are shown below:

$$\begin{aligned} Z_a &= \bar{E} \cdot (I_{1a} \cdot S + I_{0a} \cdot \bar{S}) & Z_b &= \bar{E} \cdot (I_{1b} \cdot S + I_{0b} \cdot \bar{S}) \\ Z_c &= \bar{E} \cdot (I_{1c} \cdot S + I_{0c} \cdot \bar{S}) & Z_d &= \bar{E} \cdot (I_{1d} \cdot S + I_{0d} \cdot \bar{S}) \end{aligned}$$

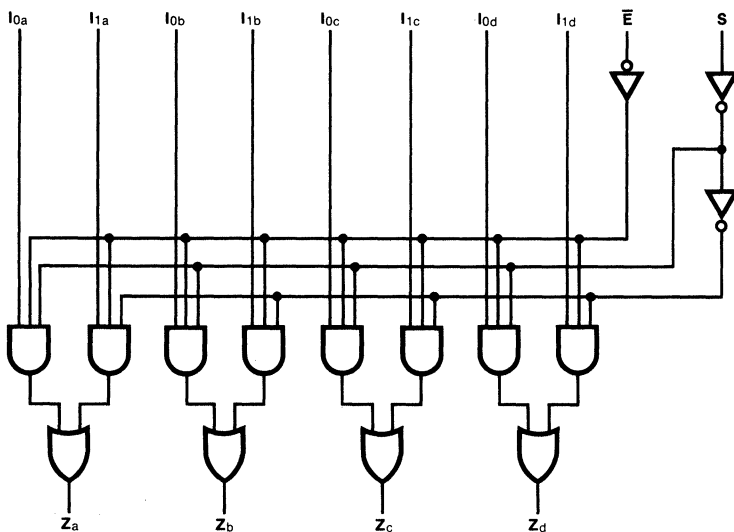
A common use of the 'F157 is the moving of data from two groups of registers to four common output busses. The particular register from which the data comes is determined by the state of the Select input. A less obvious use is as a function generator. The 'F157 can generate any four of the 16 different functions of two variables with one variable common. This is useful for implementing highly irregular logic.

### Truth Table

INPUTS				OUTPUT
$\bar{E}$	S	$I_0$	$I_1$	Z
H	X	X	X	L
L	H	X	L	L
L	H	X	H	H
L	L	L	X	L
L	L	H	X	H

H = HIGH Voltage Level  
L = LOW Voltage Level  
X = Immaterial

### Logic Diagram



**DC Characteristics over Operating Temperature Range** (unless otherwise specified)

Symbol	Parameter	54F/74F			Units	Conditions
		Min	Typ	Max		
I <sub>CC</sub>	Power Supply Current		15	23	mA	V <sub>CC</sub> = Max, All Inputs = 4.5 V

**AC Characteristics:** See Section 3 for waveforms and load configurations

Symbol	Parameter	54F/74F			54F		74F		Units	Fig. No.
		T <sub>A</sub> = +25°C, V <sub>CC</sub> = +5.0 V C <sub>L</sub> = 50 pF			T <sub>A</sub> , V <sub>CC</sub> = Mil C <sub>L</sub> = 50 pF		T <sub>A</sub> , V <sub>CC</sub> = Com C <sub>L</sub> = 50 pF			
		Min	Typ	Max	Min	Max	Min	Max		
t <sub>PLH</sub> t <sub>PHL</sub>	Propagation Delay S to Z <sub>n</sub>	4.5 3.5	10.1 6.3	13 8.0	3.5 3.5	17 11.5	4.5 3.5	15 9.0	ns	3-1 3-10
t <sub>PLH</sub> t <sub>PHL</sub>	Propagation Delay $\bar{E}$ to Z <sub>n</sub>	5.0 3.8	7.6 5.3	10 7.0	5.0 3.8	15 8.5	5.0 3.8	11.5 8.0	ns	3-1 3-3
t <sub>PLH</sub> t <sub>PHL</sub>	Propagation Delay I <sub>n</sub> to Z <sub>n</sub>	3.8 2.5	5.5 4.6	7.0 5.5	3.5 2.5	10 7.5	3.8 2.5	8.0 7.0	ns	3-1 3-4

# 54F/74F158

## Quad 2-Input Multiplexer

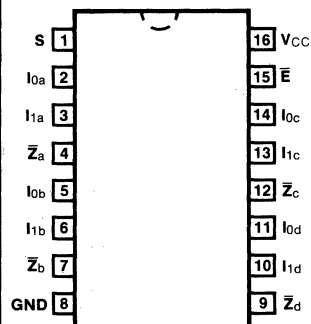
### Description

The 'F158 is a high-speed quad 2-input multiplexer. It selects four bits of data from two sources using the common Select and Enable inputs. The four buffered outputs present the selected data in the inverted form. The 'F158 can also generate any four of the 16 different functions of two variables.

**Ordering Code:** See Section 6

Pkgs	Commercial Grade	Military Grade	Pkg Type
	$V_{CC} = +5.0 \text{ V} \pm 5\%$ , $T_A = 0^\circ \text{ C to } +70^\circ \text{ C}$	$V_{CC} = +5.0 \text{ V} \pm 10\%$ , $T_A = -55^\circ \text{ C to } +125^\circ \text{ C}$	
Plastic DIP (P)	74F158PC		9B
Ceramic DIP (D)	74F158DC	54F158DM	6B
Flatpak (F)		54F158FM	4L

### Connection Diagram

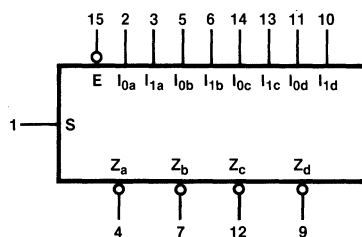


4

**Input Loading/Fan-Out:** See Section 3 for U.L. definitions

Pin Names	Description	54F/74F (U.L.) HIGH/LOW
$I_{0a} - I_{0d}$	Source 0 Data Inputs	0.5/0.375
$I_{1a} - I_{1d}$	Source 1 Data Inputs	0.5/0.375
$\overline{E}$	Enable Input (Active LOW)	0.5/0.375
S	Select Input	0.5/0.375
$\overline{Z}_a - \overline{Z}_d$	Inverted Outputs	25/12.5

### Logic Symbol



$V_{CC} = \text{Pin } 16$   
 $GND = \text{Pin } 8$

## Functional Description

The 'F158 quad 2-input multiplexer selects four bits of data from two sources under the control of a common Select input (S) and presents the data in inverted form at the four outputs. The Enable input ( $\bar{E}$ ) is active LOW. When  $\bar{E}$  is HIGH, all of the outputs ( $\bar{Z}$ ) are forced HIGH regardless of all other inputs. The 'F158 is the logic implementation of a 4-pole, 2-position switch where the position of the switch is determined by the logic levels supplied to the Select input.

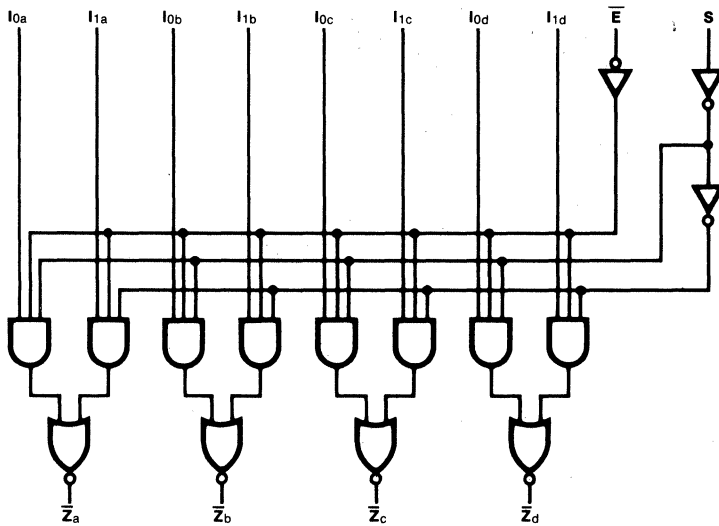
A common use of the 'F158 is the moving of data from two groups of registers to four common output busses. The particular register from which the data comes is determined by the state of the Select input. A less obvious use is as a function generator. The 'F158 can generate four functions of two variables with one variable common. This is useful for implementing gating functions.

## Truth Table

INPUTS				OUTPUTS
$\bar{E}$	S	I <sub>0</sub>	I <sub>1</sub>	$\bar{Z}$
H	X	X	X	H
L	L	L	X	H
L	L	H	X	L
L	H	X	L	H
L	H	X	H	L

H = HIGH Voltage Level  
 L = LOW Voltage Level  
 X = Immaterial

## Logic Diagram



**DC Characteristics over Operating Temperature Range** (unless otherwise specified)

Symbol	Parameter	54F/74F			Units	Conditions
		Min	Typ	Max		
I <sub>CC</sub>	Power Supply Current		10	15	mA	V <sub>CC</sub> = Max*

**AC Characteristics:** See Section 3 for waveforms and load configurations

Symbol	Parameter	54F/74F			54F		74F		Units	Fig. No.
		T <sub>A</sub> = +25°C V <sub>CC</sub> = +5.0 V C <sub>L</sub> = 50 pF			T <sub>A</sub> , V <sub>CC</sub> = Mil C <sub>L</sub> = 50 pF		T <sub>A</sub> , V <sub>CC</sub> = Com C <sub>L</sub> = 50 pF			
		Min	Typ	Max	Min	Max	Min	Max		
t <sub>PLH</sub> t <sub>PHL</sub>	Propagation Delay S to $\bar{Z}$	4.0 4.0	6.4 6.9	8.5 9.0	4.0 4.0	10.5 10.5	4.0 4.0	9.5 10.5	ns	3-1 3-10
t <sub>PLH</sub> t <sub>PHL</sub>	Propagation Delay $\bar{E}$ to $\bar{Z}$	4.5 3.5	6.2 6.4	8.0 8.5	4.5 3.5	9.5 9.5	4.5 3.5	9.0 9.5	ns	3-1 3-4
t <sub>PLH</sub> t <sub>PHL</sub>	Propagation Delay I <sub>N</sub> to $\bar{Z}$	3.0 2.0	4.4 3.3	5.9 4.5	2.5 2.0	8.5 6.0	3.0 2.0	7.0 5.5	ns	3-1 3-3

\*I<sub>CC</sub> measured with outputs open and 4.5 V applied to all inputs.

# 54F/74F160 • 54F/74F162

## Synchronous Presetable BCD Decade Counter

### Description

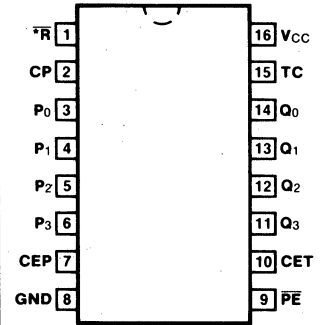
The 'F160 and 'F162 are high-speed synchronous decade counters operating in the BCD (8421) sequence. They are synchronously presetable for application in programmable dividers and have two types of Count Enable inputs plus a Terminal Count output for versatility in forming synchronous multistage counters. The 'F160 has an asynchronous Master Reset input that overrides all other inputs and forces the outputs LOW. The 'F162 has a Synchronous Reset input that overrides counting and parallel loading and allows all outputs to be simultaneously reset on the rising edge of the clock.

- Synchronous Counting and Loading
- High-speed Synchronous Expansion
- Typical Count Rate of 125 MHz

Ordering Code: See Section 6

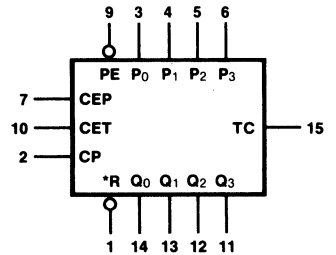
Pkgs	Commercial Grade	Military Grade	Pkg Type
	V <sub>CC</sub> = +5.0 V ±5%, T <sub>A</sub> = 0° C to +70° C	V <sub>CC</sub> = +5.0 V ±10%, T <sub>A</sub> = -55° C to +125° C	
Plastic DIP (P)	74F160PC, 74F162PC		9B
Ceramic DIP (D)	74F160DC, 74F162DC	54F160DM, 54F162DM	7B
Flatpak (F)		54F160FM, 54F162FM	4L

### Connection Diagram



\*MR for '160  
\*SR for '162

### Logic Symbol



V<sub>CC</sub> = Pin 16     \*MR for '160  
GND = Pin 8       \*SR for '162

Input Loading/Fan-Out: See Section 3 for U.L. definitions

Pin Names	Description	54F/74F (U.L.) HIGH/LOW
CEP	Count Enable Parallel Input	0.5/0.375
CET	Count Enable Trickle Input	0.5/0.75
CP	Clock Pulse Input (Active Rising Edge)	0.5/0.375
$\overline{MR}$ ('F160)	Asynchronous Master Reset Input (Active LOW)	0.5/0.375
$\overline{SR}$ ('F162)	Synchronous Reset Input (Active LOW)	0.5/0.75
P <sub>0</sub> -P <sub>3</sub>	Parallel Data Inputs	0.5/0.375
$\overline{PE}$	Parallel Enable Input (Active LOW)	0.5/0.75
Q <sub>0</sub> -Q <sub>3</sub>	Flip-flop Outputs	25/12.5
TC	Terminal Count Output	25/12.5

### Functional Description

The 'F160 and 'F162 count modulo-10 in the BCD (8421) sequence. From state 9 (HLLH) they increment to state 0 (LLLL). The clock inputs of all flip-flops are driven in parallel through a clock buffer. Thus all changes of the Q outputs (except due to Master Reset of the 'F160) occur as a result of, and synchronous with, the LOW-to-HIGH transition of the CP input signal. The circuits have four fundamental modes of operation, in order of precedence: asynchronous reset ('F160), synchronous reset ('F162), parallel load, count-up and hold. Five control inputs — Master Reset ( $\overline{MR}$ , 'F160), Synchronous Reset ( $\overline{SR}$ , 'F162), Parallel Enable ( $\overline{PE}$ ), Count Enable Parallel (CEP) and Count Enable Trickle (CET) — determine the mode of operation, as shown in the Mode Select Table. A LOW signal on  $\overline{MR}$  overrides all other inputs and asynchronously forces all outputs LOW. A LOW signal on  $\overline{SR}$  overrides counting and parallel loading and allows all outputs to go LOW on the next rising edge of CP. A LOW signal on  $\overline{PE}$  overrides counting and allows information on the Parallel Data ( $P_n$ ) inputs to be loaded into the flip-flops on the next rising edge of CP. With  $\overline{PE}$  and  $\overline{MR}$  ('F160) or  $\overline{SR}$  ('F162) HIGH, CEP and CET permit counting when both are HIGH. Conversely, a LOW signal on either CEP or CET inhibits counting.

**Mode Select Table**

$\overline{SR}$	$\overline{PE}$	CET	CEP	Action on the Rising Clock Edge ( $\uparrow$ )
L	X	X	X	RESET (Clear)
H	L	X	X	LOAD ( $P_n \rightarrow Q_n$ )
H	H	H	H	COUNT (Increment)
H	H	L	X	NO CHANGE (Hold)
H	H	X	L	NO CHANGE (Hold)

\* For the 'F162 only  
 H = HIGH Voltage Level  
 L = LOW Voltage Level  
 X = Immaterial

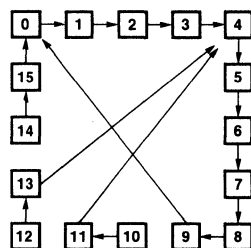
The 'F160 and 'F162 use D-type edge-triggered flip-flops and changing the  $\overline{SR}$ ,  $\overline{PE}$ , CEP and CET inputs when the CP is in either state does not cause errors, provided that the recommended setup and hold times, with respect to the rising edge of CP, are observed.

The Terminal Count (TC) output is HIGH when CET is HIGH and the counter is in state 9. To implement synchronous multistage counters, the TC outputs can be used with the CEP and CET inputs in two different ways. Please refer to the 'F568 data sheet. The TC output is subject to decoding spikes due to internal race conditions and is therefore not recommended for use as a clock or asynchronous reset for flip-flops, counters or registers. In the 'F160, 'F162 decade counters, the TC output is fully decoded and can only be HIGH in state 9. If a decade counter is preset to an illegal state, or assumes an illegal state when power is applied, it will return to the normal sequence within two counts, as shown in the State Diagram.

$$\text{Logic Equations: Count Enable} = \text{CEP} \cdot \text{CET} \cdot \text{PE}$$

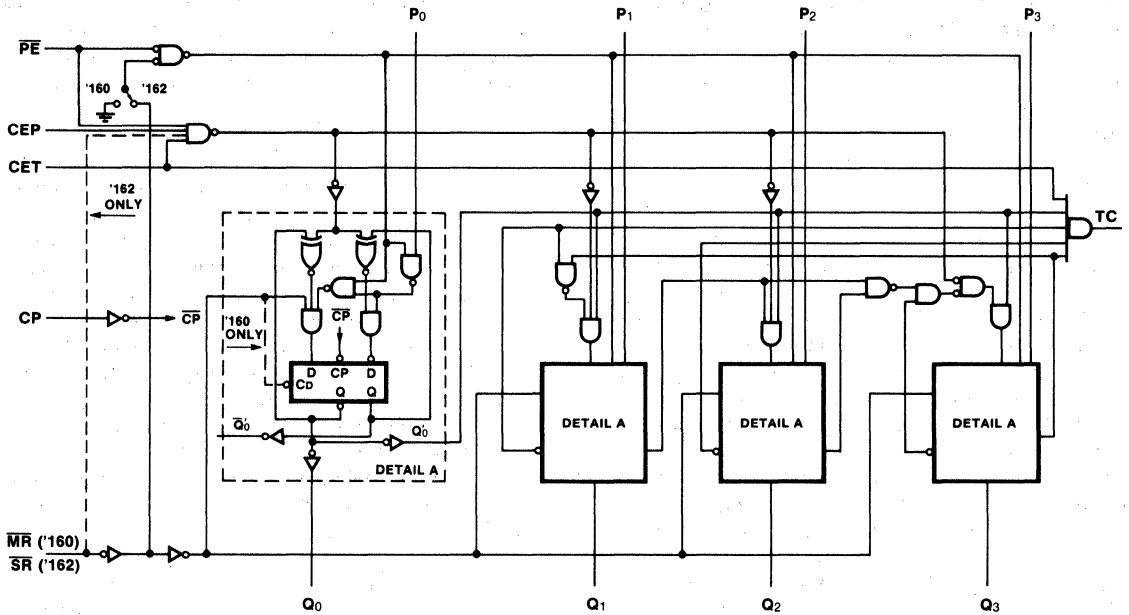
$$\text{TC} = Q_0 \cdot \overline{Q_1} \cdot \overline{Q_2} \cdot Q_3 \cdot \text{CET}$$

**State Diagram**





Logic Diagram



Please note that this diagram is provided only for the understanding of logic operations and should not be used to estimate propagation delays.

DC Characteristics over Operating Temperature Range (unless otherwise specified)

Symbol	Parameter	54F/74F			Units	Conditions
		Min	Typ	Max		
I <sub>CC</sub>	Power Supply Current		33	50	mA	V <sub>CC</sub> = Max

**AC Characteristics:** See Section 3 for waveforms and load configurations

Symbol	Parameter	54F/74F			54F		74F		Units	Fig. No.
		T <sub>A</sub> = +25°C, V <sub>CC</sub> = +5.0 V C <sub>L</sub> = 50 pF			T <sub>A</sub> , V <sub>CC</sub> = Mil C <sub>L</sub> = 50 pF		T <sub>A</sub> , V <sub>CC</sub> = Com C <sub>L</sub> = 50 pF			
		Min	Typ	Max	Min	Max	Min	Max		
f <sub>max</sub>	Maximum Count Frequency	100	125					MHz	3-1, 3-7	
t <sub>PLH</sub> t <sub>PHL</sub>	Propagation Delay CP to Q <sub>n</sub> ( $\overline{PE}$ Input HIGH)	3.0 4.0	5.0 7.0	7.0 10				ns	3-1 3-7	
t <sub>PLH</sub> t <sub>PHL</sub>	Propagation Delay CP to Q <sub>n</sub> ( $\overline{PE}$ Input LOW)	4.0 5.0	7.0 8.0	10 11						
t <sub>PLH</sub> t <sub>PHL</sub>	Propagation Delay CP to TC	6.0 5.5	10 9.0	14 12.5				ns	3-1 3-7	
t <sub>PLH</sub> t <sub>PHL</sub>	Propagation Delay CET to TC	2.5 3.0	4.0 5.0	5.5 7.0						ns
t <sub>PHL</sub>	Propagation Delay MR to Q <sub>n</sub> ('F160)	6.0	10	14				ns	3-1 3-11	

4

**AC Operating Requirements:** See Section 3 for waveforms

Symbol	Parameter	54F/74F			54F		74F		Units	Fig. No.
		T <sub>A</sub> = +25°C, V <sub>CC</sub> = +5.0 V			T <sub>A</sub> , V <sub>CC</sub> = Mil		T <sub>A</sub> , V <sub>CC</sub> = Com			
		Min	Typ	Max	Min	Max	Min	Max		
t <sub>s</sub> (H) t <sub>s</sub> (L)	Setup Time, HIGH or LOW P <sub>n</sub> to CP	3.0 5.0						ns	3-5	
t <sub>h</sub> (H) t <sub>h</sub> (L)	Hold Time, HIGH or LOW P <sub>n</sub> to CP	3.0 3.0								
t <sub>s</sub> (H) t <sub>s</sub> (L)	Setup Time, HIGH or LOW $\overline{PE}$ or $\overline{SR}$ to CP	10 7.0						ns	3-5	
t <sub>h</sub> (H) t <sub>h</sub> (L)	Hold Time, HIGH or LOW $\overline{PE}$ or $\overline{SR}$ to CP	2.0 0								
t <sub>s</sub> (H) t <sub>s</sub> (L)	Setup Time, HIGH or LOW CEP or CET to CP	10 4.0						ns	3-5	
t <sub>h</sub> (H) t <sub>h</sub> (L)	Hold Time, HIGH or LOW CEP or CET to CP	0 0								
t <sub>w</sub> (H) t <sub>w</sub> (L)	Clock Pulse Width, HIGH or LOW	4.0 5.0						ns	3-7	
t <sub>w</sub> (L)	MR Pulse Width LOW ('F160)	6.0								
t <sub>rec</sub>	Recovery Time MR to CP ('F160)	5.0						ns	3-11	

■ Test limits in screened columns are preliminary.

# 54F/74F161 • 54F/74F163

## Synchronous Presettable Binary Counter

### Description

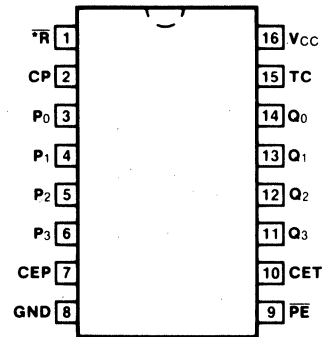
The 'F161 and 'F163 are high-speed synchronous modulo-16 binary counters. They are synchronously presettable for application in programmable dividers and have two types of Count Enable inputs plus a Terminal Count output for versatility in forming synchronous multistage counters. The 'F161 has an asynchronous Master Reset input that overrides all other inputs and forces the outputs LOW. The 'F163 has a Synchronous Reset input that overrides the counting and parallel loading and allows the outputs to be simultaneously reset on the rising edge of the clock.

- Synchronous Counting and Loading
- High Speed Synchronous Expansion
- Typical Count Frequency of 125 MHz

Ordering Code: See Section 6

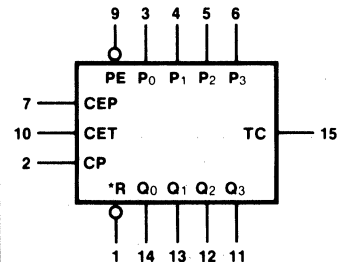
Pkgs	Commercial Grade	Military Grade	Pkg Type
	$V_{CC} = +5.0 \pm 5\%$ , $T_A = 0^\circ\text{C to } +70^\circ\text{C}$	$V_{CC} = +5.0\text{ V } \pm 10\%$ , $T_A = -55^\circ\text{C to } +125^\circ\text{C}$	
Plastic DIP (P)	74F161PC, 74F163PC		9B
Ceramic DIP (D)	74F161DC, 74F163DC	54F161DM, 54F163DM	7B
Flatpak (F)		54F161FM, 54F163FM	4L

### Connection Diagram



\*MR for '161  
\*SR for '163

### Logic Symbol



\*MR for '161  $V_{CC} = \text{Pin } 16$   
\*SR for '163  $\text{GND} = \text{Pin } 8$


Input Loading/Fan-Out: See Section 3 for U.L. definitions

Pin Names	Description	54F/74F (U.L.) HIGH/LOW
CEP	Count Enable Parallel Input	0.5/0.375
CET	Count Enable Trickle Input	0.5/0.75
CP	Clock Pulse Input (Active Rising Edge)	0.5/0.375
$\overline{\text{MR}}$ ('F161)	Asynchronous Master Reset Input (Active LOW)	0.5/0.375
$\overline{\text{SR}}$ ('F163)	Synchronous Reset Input (Active LOW)	0.5/0.75
$P_0 - P_3$	Parallel Data Inputs	0.5/0.375
$\overline{\text{PE}}$	Parallel Enable Input (Active LOW)	0.5/0.75
$Q_0 - Q_3$	Flip-flop Outputs	25/12.5
TC	Terminal Count Output	25/12.5

### Functional Description

The 'F161 and 'F163 count in modulo-16 binary sequence. From state 15 (HHHH) they increment to state 0 (LLLL). The clock inputs of all flip-flops are driven in parallel through a clock buffer. Thus all changes of the Q outputs (except due to Master Reset of the 'F161) occur as a result of, and synchronous with, the LOW-to-HIGH transition of the CP input signal. The circuits have four fundamental modes of operation, in order of precedence: asynchronous reset ('F161), synchronous reset ('F163), parallel load, count-up and hold. Five control inputs — Master Reset ( $\overline{MR}$ , 'F161), Synchronous Reset ( $\overline{SR}$ , 'F163), Parallel Enable ( $\overline{PE}$ ), Count Enable Parallel (CEP) and Count Enable Trickle (CET) — determine the mode of operation, as shown in the Mode Select Table. A LOW signal on  $\overline{MR}$  overrides all other inputs and asynchronously forces all outputs LOW. A LOW signal on  $\overline{SR}$  overrides counting and parallel loading and allows all outputs to go LOW on the next rising edge of CP. A LOW signal on  $\overline{PE}$  overrides counting and allows information on the Parallel Data ( $P_n$ ) inputs to be loaded into the flip-flops on the next rising edge of CP. With  $\overline{PE}$  and  $\overline{MR}$  ('F161) or  $\overline{SR}$  ('F163) HIGH, CEP and CET permit counting when both are HIGH. Conversely, a LOW signal on either CEP or CET inhibits counting.

Mode Select Table

$\overline{SR}$	$\overline{PE}$	CET	CEP	Action on the Rising Clock Edge (  )
L	X	X	X	RESET (Clear)
H	L	X	X	LOAD ( $P_n \rightarrow Q_n$ )
H	H	H	H	COUNT (Increment)
H	H	L	X	NO CHANGE (Hold)
H	H	X	L	NO CHANGE (Hold)

\* For 'F163 only

H = HIGH Voltage Level

L = LOW Voltage Level

X = Immaterial

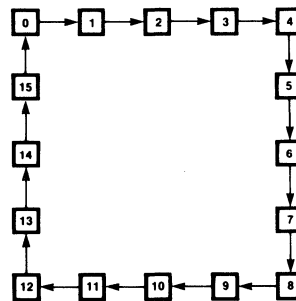
The 'F161 and 'F163 use D-type edge-triggered flip-flops and changing the  $\overline{SR}$ ,  $\overline{PE}$ , CEP and CET inputs when the CP is in either state does not cause errors, provided that the recommended setup and hold times, with respect to the rising edge of CP, are observed.

The Terminal Count (TC) output is HIGH when CET is HIGH and the counter is in state 15. To implement synchronous multistage counters, the TC outputs can be used with the CEP and CET inputs in two different ways. Please refer to the 'F568 data sheet. The TC output is subject to decoding spikes due to internal race conditions and is therefore not recommended for use as a clock or asynchronous reset for flip-flops, counters or registers.

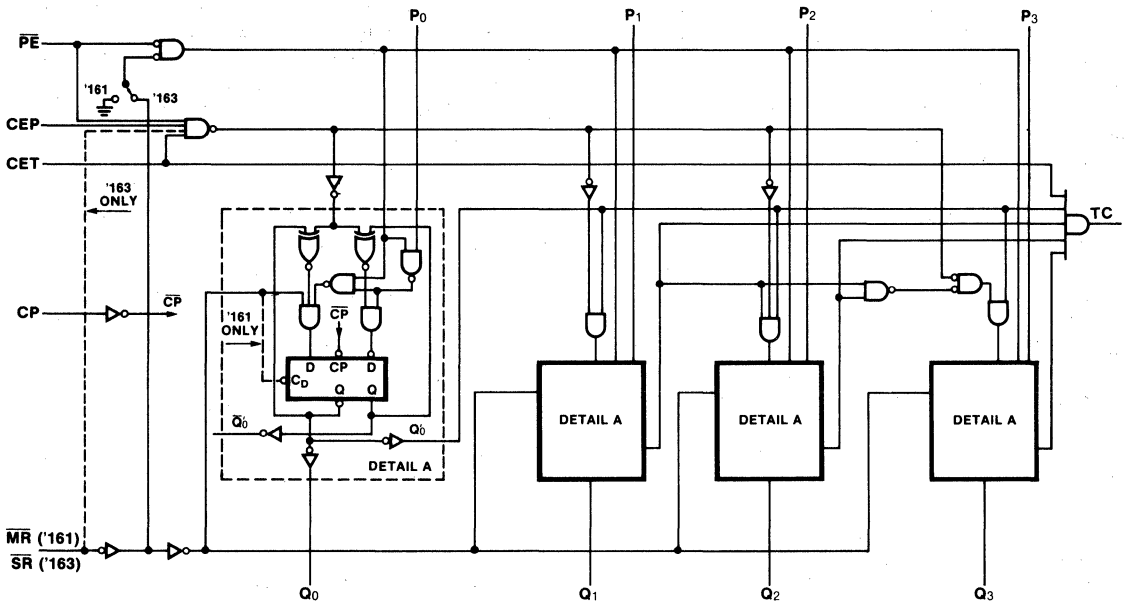
Logic Equations: Count Enable = CEP • CET • PE

$$TC = Q_0 \cdot Q_1 \cdot Q_2 \cdot Q_3 \cdot CET$$

State Diagram



## Logic Diagram



Please note that this diagram is provided only for the understanding of logic operations and should not be used to estimate propagation delays.

### DC Characteristics over Operating Temperature Range (unless otherwise specified)

Symbol	Parameter	54F/74F			Units	Conditions
		Min	Typ	Max		
I <sub>CC</sub>	Power Supply Current		33	50	mA	V <sub>CC</sub> = Max

**AC Characteristics:** See Section 3 for waveforms and load configurations

Symbol	Parameter	54F/74F			54F		74F		Units	Fig. No.
		$T_A = +25^\circ\text{C}$ , $V_{CC} = +5.0\text{ V}$ $C_L = 50\text{ pF}$			$T_A, V_{CC} =$ Mil $C_L = 50\text{ pF}$		$T_A, V_{CC} =$ Com $C_L = 50\text{ pF}$			
		Min	Typ	Max	Min	Max	Min	Max		
$f_{\text{max}}$	Maximum Count Frequency	100	125					MHz	3-1, 3-7	
$t_{\text{PLH}}$ $t_{\text{PHL}}$	Propagation Delay CP to $Q_n$ (PE Input HIGH)	3.0 4.0	5.0 7.0	7.0 10				ns	3-1 3-7	
$t_{\text{PLH}}$ $t_{\text{PHL}}$	Propagation Delay CP to $Q_n$ (PE Input LOW)	4.0 5.0	7.0 8.0	10 11						
$t_{\text{PLH}}$ $t_{\text{PHL}}$	Propagation Delay CP to TC	6.0 5.5	10 9.0	14 12.5				ns	3-1 3-7	
$t_{\text{PLH}}$ $t_{\text{PHL}}$	Propagation Delay CET to TC	2.5 3.0	4.0 5.0	5.5 7.0						ns
$t_{\text{PHL}}$	Propagation Delay $\overline{\text{MR}}$ to $Q_n$ ('F161)	6.0	10	14				ns	3-1 3-11	

**AC Operating Requirements:** See Section 3 for waveforms

Symbol	Parameter	54F/74F			54F		74F		Units	Fig. No.
		$T_A = +25^\circ\text{C}$ , $V_{CC} = +5.0\text{ V}$			$T_A, V_{CC} =$ Mil		$T_A, V_{CC} =$ Com			
		Min	Typ	Max	Min	Max	Min	Max		
$t_s$ (H) $t_s$ (L)	Setup Time, HIGH or LOW $P_n$ to CP	3.0 5.0						ns	3-5	
$t_h$ (H) $t_h$ (L)	Hold Time, HIGH or LOW $P_n$ to CP	3.0 3.0								
$t_s$ (H) $t_s$ (L)	Setup Time, HIGH or LOW $\overline{\text{PE}}$ or $\overline{\text{SR}}$ to CP	10 7.0						ns	3-5	
$t_h$ (H) $t_h$ (L)	Hold Time, HIGH or LOW $\overline{\text{PE}}$ or $\overline{\text{SR}}$ to CP	2.0 0								
$t_s$ (H) $t_s$ (L)	Setup Time, HIGH or LOW CEP or CET to CP	10 4.0						ns	3-5	
$t_h$ (H) $t_h$ (L)	Hold Time, HIGH or LOW CEP or CET to CP	0 0								
$t_w$ (H) $t_w$ (L)	Clock Pulse Width, HIGH or LOW	4.0 5.0						ns	3-7	
$t_w$ (L)	$\overline{\text{MR}}$ Pulse Width LOW ('F161)	6.0								
$t_{\text{rec}}$	Recovery Time $\overline{\text{MR}}$ to CP ('F161)	5.0						ns	3-11	

■ Test limits in screened columns are preliminary.

# 54F/74F164

## Serial-In Parallel-Out Shift Register

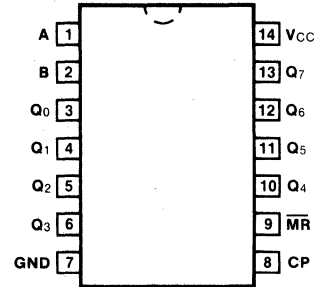
### Connection Diagram

#### Description

The 'F164 is a high speed 8-bit serial-in parallel-out shift register. Serial data is entered through a 2-input AND gate synchronous with the LOW-to-HIGH transition of the clock. The device features an asynchronous Master Reset which clears the register, setting all outputs LOW independent of the clock.

- Typical shift Frequency of 90 MHz
- Asynchronous Master Reset
- Gated Serial Data Input
- Fully Synchronous Data Transfers

Ordering Code: See Section 6

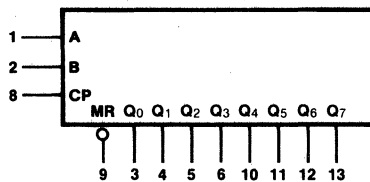


Pkgs	Commercial Grade	Military Grade	Pkg Type
	V <sub>CC</sub> = +5.0 V ±5%, T <sub>A</sub> = 0° C to +70° C	V <sub>CC</sub> = +5.0 V ±10%, T <sub>A</sub> = -55° C to +125° C	
Plastic DIP (P)	74F164PC		9A
Ceramic DIP (D)	74F164DC	54F164DM	6A
Flatpak (F)		54F164FM	3I

Input Loading/Fan-Out: See Section 3 for U.L. definitions

Pin Names	Description	54F/74F (U.L.) HIGH/LOW
A, B	Data Inputs	0.5/0.375
CP	Clock Pulse Input (Active Rising Edge)	0.5/0.375
MR	Master Reset Input (Active LOW)	0.5/0.375
Q <sub>0</sub> - Q <sub>7</sub>	Outputs	25/12.5

#### Logic Symbol



V<sub>CC</sub> = Pin 14  
GND = Pin 7

**Functional Description**

The 'F164 is an edge-triggered 8-bit shift register with serial data entry and an output from each of the eight stages. Data is entered serially through one of two inputs (A or B); either of these inputs can be used as an active-HIGH Enable for data entry through the other input. An unused input must be tied HIGH.

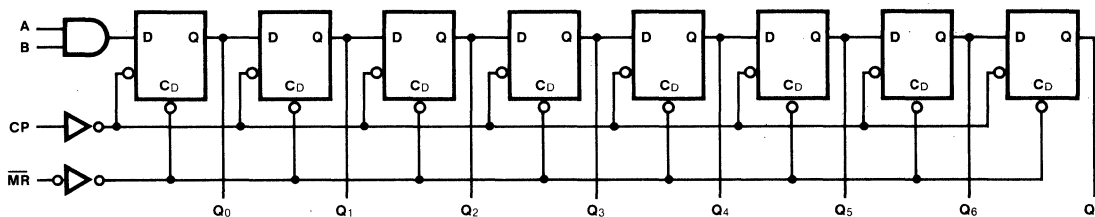
Each LOW-to-HIGH transition on the Clock (CP) input shifts data one place to the right and enters into Q<sub>0</sub> the logical AND of the two data inputs (A • B) that existed before the rising clock edge. A LOW level on the Master Reset ( $\overline{MR}$ ) input overrides all other inputs and clears the register asynchronously, forcing all Q outputs LOW.

**Mode Select Table**

OPERATING MODE	INPUTS			OUTPUTS	
	$\overline{MR}$	A	B	Q <sub>0</sub>	Q <sub>1</sub> — Q <sub>7</sub>
Reset (Clear)	L	X	X	L	L — L
Shift	H	l	l	L	q <sub>0</sub> — q <sub>6</sub>
	H	l	h	L	q <sub>0</sub> — q <sub>6</sub>
	H	h	l	L	q <sub>0</sub> — q <sub>6</sub>
	H	h	h	H	q <sub>0</sub> — q <sub>6</sub>


L (l) = LOW Voltage Levels  
 H (h) = HIGH Voltage Levels  
 X = Immaterial  
 q<sub>n</sub> = Lower case letters indicate the state of the referenced input or output one setup time prior to the LOW-to-HIGH clock transition.

**Logic Diagram**





**DC Characteristics over Operating Temperature Range** (unless otherwise specified)

Symbol	Parameter	54F/74F			Units	Conditions
		Min	Typ	Max		
I <sub>CC</sub>	Power Supply Current		35	55	mA	A, B = GND, V <sub>CC</sub> = Max, CP = 2.4 V, MR = 

**AC Characteristics:** See Section 3 for waveforms and load configurations

Symbol	Parameter	54F/74F			54F		74F		Units	Fig. No.
		T <sub>A</sub> = +25°C, V <sub>CC</sub> = +5.0 V, C <sub>L</sub> = 50 pF			T <sub>A</sub> , V <sub>CC</sub> = Mil, C <sub>L</sub> = 50 pF		T <sub>A</sub> , V <sub>CC</sub> = Com, C <sub>L</sub> = 50 pF			
		Min	Typ	Max	Min	Max	Min	Max		
f <sub>max</sub>	Maximum Clock Frequency	80	90			80		MHz	3-1, 3-7	
t <sub>PLH</sub>	Propagation Delay CP to Q <sub>n</sub>	4.5	6.0	8.0		4.5	9.0	ns	3-1, 3-7	
t <sub>PHL</sub>	Propagation Delay MR to Q <sub>n</sub>	5.0	7.5	10		5.0	11	ns	3-1, 3-11	

**AC Operating Requirements:** See Section 3 for waveforms

Symbol	Parameter	54F/74F			54F		74F		Units	Fig. No.
		T <sub>A</sub> = +25°C, V <sub>CC</sub> = +5.0 V			T <sub>A</sub> , V <sub>CC</sub> = Mil		T <sub>A</sub> , V <sub>CC</sub> = Com			
		Min	Typ	Max	Min	Max	Min	Max		
t <sub>s</sub> (H)	Setup Time, HIGH or LOW	7.0				7.0		ns	3-5	
t <sub>s</sub> (L)	A or B to CP	7.0				7.0				
t <sub>h</sub> (H)	Hold Time, HIGH or LOW	1.0				1.0				
t <sub>h</sub> (L)	A or B to CP	1.0				1.0				
t <sub>w</sub> (H)	CP Pulse Width, HIGH or LOW	4.0				4.0		ns	3-7	
t <sub>w</sub> (L)		7.0				7.0				
t <sub>w</sub> (L)	MR Pulse Width LOW	7.0				7.0		ns	3-11	
t <sub>rec</sub>	Recovery Time MR to CP	7.0				7.0		ns	3-11	

# 54F/74F168 • 54F/74F169

## 4-Stage Synchronous Bidirectional Counters

### Description

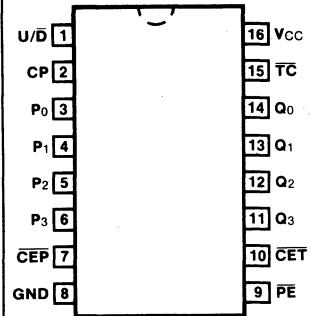
The 'F168 and 'F169 are fully synchronous 4-stage up/down counters. The 'F168 is a BCD decade counter; the 'F169 is a modulo-16 binary counter. Both feature a preset capability for programmable operation, carry lookahead for easy cascading and a U/D input to control the direction of counting. All state changes, whether in counting or parallel loading, are initiated by the LOW-to-HIGH transition of the Clock.

- Synchronous Counting and Loading
- Built-in Lookahead Carry Capability
- Presetable for Programmable Operation

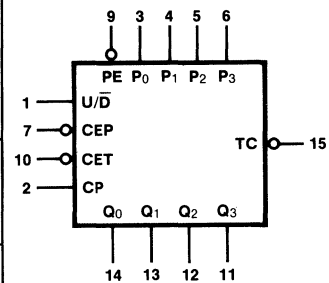
Ordering Code: See Section 6

Pkgs	Commercial Grade	Military Grade	Pkg Type
	V <sub>CC</sub> = +5.0 ±5%, T <sub>A</sub> = 0°C to +70°C	V <sub>CC</sub> = + 5.0 V ±10%, T <sub>A</sub> = -55°C to +125°C	
Plastic DIP (P)	74F168PC, 74F169PC		9B
Ceramic DIP (D)	74F168DC, 74F169DC	54F168DM, 54F169DM	6B
Flatpak (F)		54F168FM, 54F169FM	4L

### Connection Diagram



### Logic Symbol



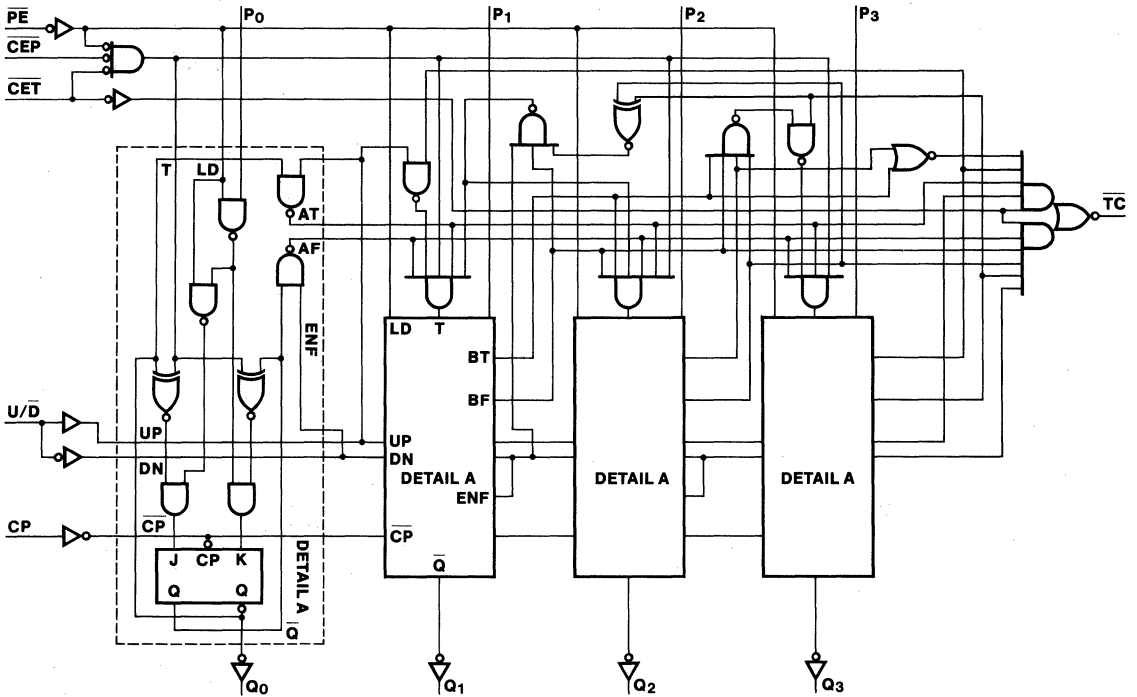
V<sub>CC</sub> = Pin 16  
GND = Pin 8

Input Loading/Fan-Out: See Section 3 for U.L. definitions

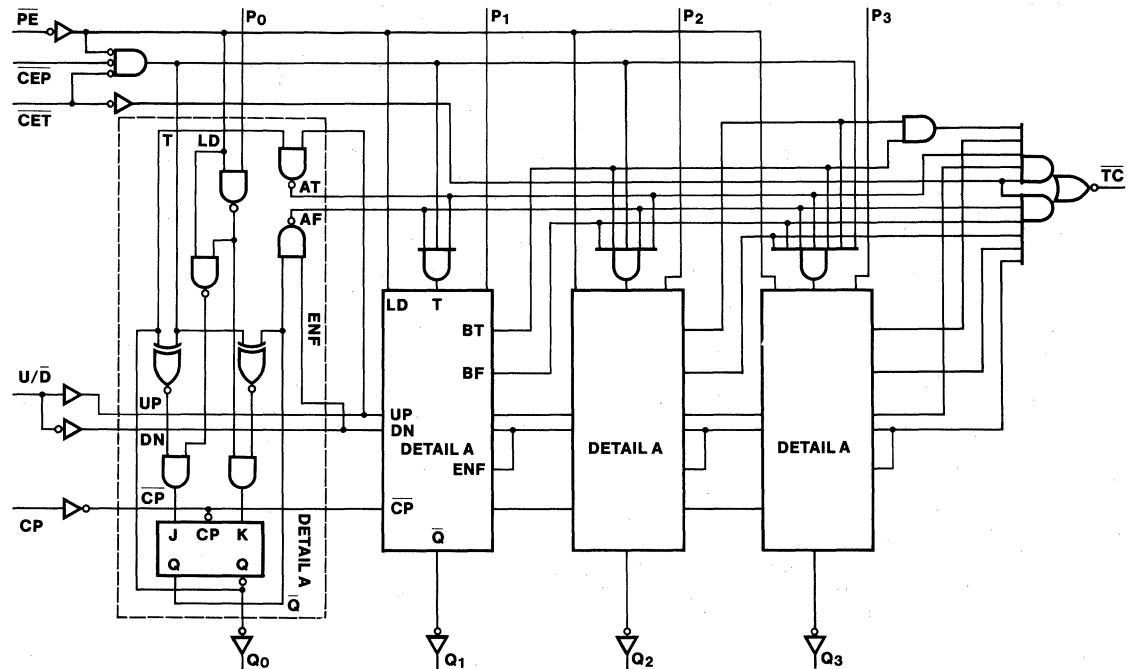
Pin Names	Description	54F/74F (U.L.) HIGH/LOW
CEP	Count Enable Parallel Input (Active LOW)	0.5/0.375
CET	Count Enable Trickle Input (Active LOW)	0.5/0.750
CP	Clock Pulse Input (Active Rising Edge)	0.5/0.375
P <sub>0</sub> - P <sub>3</sub>	Parallel Data Inputs	0.5/0.375
PE	Parallel Enable Input (Active LOW)	0.5/0.375
U/D	Up-Down Count Control Input	0.5/0.375
Q <sub>0</sub> - Q <sub>3</sub>	Flip-flop Outputs	25/12.5
TC	Terminal Count Output (Active LOW)	25/12.5

Logic Diagrams

'F168



'F169



Please note that these diagrams are provided only for the understanding of logic operations and should not be used to estimate propagation delays.

**Functional Description**

The 'F168 and 'F169 use edge-triggered J-K-type flip-flops and have no constraints on changing the control or data input signals in either state of the Clock. The only requirement is that the various inputs attain the desired state at least a setup time before the rising edge of the clock and remain valid for the recommended hold time thereafter. The parallel load operation takes precedence over the other operations, as indicated in the Mode Select Table. When  $\overline{PE}$  is LOW, the data on the  $P_0$ - $P_3$  inputs enters the flip-flops on the next rising edge of the Clock. In order for counting to occur, both  $\overline{CEP}$  and  $\overline{CET}$  must be LOW and  $\overline{PE}$  must be HIGH; the  $U/\overline{D}$  input then determines the direction of counting. The Terminal Count ( $\overline{TC}$ ) output is normally HIGH and goes LOW, provided that  $\overline{CET}$  is LOW, when a counter reaches zero in the Count Down mode or reaches 9 (15 for the 'F169) in the Count Up mode. The  $\overline{TC}$  output state is not a function of the Count Enable Parallel ( $\overline{CEP}$ ) input level. The  $\overline{TC}$  output of the 'F168 decade counter can also be LOW in the illegal states 11, 13 and 15, which can occur when power is turned on or via parallel loading. If an illegal state occurs, the 'F168 will return to the legitimate sequence within two counts. Since the  $\overline{TC}$  signal is derived by decoding the flip-flop states, there exists the possibility of decoding spikes on  $\overline{TC}$ . For this reason the use of  $\overline{TC}$  as a clock signal is not recommended (see logic equations below).

- 1) Count Enable =  $\overline{CEP} \cdot \overline{CET} \cdot \overline{PE}$
- 2) Up:  $\overline{TC} = Q_0 \cdot Q_3 \cdot (U/\overline{D}) \cdot \overline{CET}$
- 3) Down:  $\overline{TC} = Q_0 \cdot Q_1 \cdot Q_2 \cdot Q_3 \cdot (U/\overline{D}) \cdot \overline{CET}$

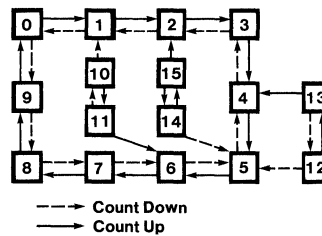
**Mode Select Table**

$\overline{PE}$	$\overline{CEP}$	$\overline{CET}$	$U/\overline{D}$	Action on Rising Clock Edge
L	X	X	X	Load ( $P_n - Q_n$ )
H	L	L	H	Count Up (Increment)
H	L	L	L	Count Down (Decrement)
H	H	X	X	No Change (Hold)
H	X	H	X	No Change (Hold)

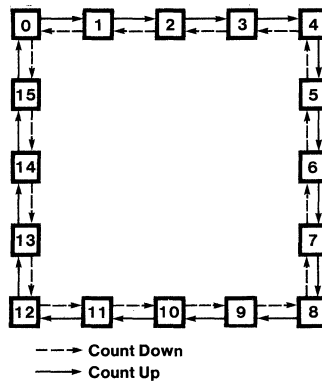
H = HIGH Voltage Level  
 L = LOW Voltage Level  
 X = Immaterial

**State Diagrams**

'F168



'F169



4

**DC Characteristics over Operating Temperature Range** (unless otherwise specified)

Symbol	Parameter	54F/74F			Units	Conditions
		Min	Typ	Max		
I <sub>CC</sub>	Power Supply Current		35	52	mA	V <sub>CC</sub> = Max

**AC Characteristics:** See Section 3 for waveforms and load configurations

Symbol	Parameter	54F/74F			54F		74F		Units	Fig. No.
		T <sub>A</sub> = +25°C, V <sub>CC</sub> = +5.0 V C <sub>L</sub> = 50 pF			T <sub>A</sub> , V <sub>CC</sub> = Mil C <sub>L</sub> = 50 pF		T <sub>A</sub> , V <sub>CC</sub> = Com C <sub>L</sub> = 50 pF			
		Min	Typ	Max	Min	Max	Min	Max		
f <sub>max</sub>	Maximum Clock Frequency	75							MHz	3-1, 3-7
t <sub>PLH</sub> t <sub>PHL</sub>	Propagation Delay CP to Q <sub>n</sub> ( $\overline{PE}$ HIGH or LOW)	4.0	7.0	10					ns	3-1, 3-7
t <sub>PLH</sub> t <sub>PHL</sub>	Propagation Delay CP to $\overline{TC}$	6.5	10.5	15					ns	3-1, 3-7
t <sub>PLH</sub> t <sub>PHL</sub>	Propagation Delay $\overline{CET}$ to $\overline{TC}$	4.0	6.5	9.0					ns	3-1, 3-4
t <sub>PLH</sub> t <sub>PHL</sub>	Propagation Delay U/ $\overline{D}$ to $\overline{TC}$	4.0	6.5	9.0					ns	3-1, 3-10

**AC Operating Requirements:** See Section 3 for waveforms

Symbol	Parameter	54F/74F			54F		74F		Units	Fig. No.
		T <sub>A</sub> = +25°C, V <sub>CC</sub> = +5.0 V			T <sub>A</sub> , V <sub>CC</sub> = Mil		T <sub>A</sub> , V <sub>CC</sub> = Com			
		Min	Typ	Max	Min	Max	Min	Max		
t <sub>s</sub> (H) t <sub>s</sub> (L)	Setup Time, HIGH or LOW P <sub>n</sub> to CP	5.0							ns	3-5
t <sub>h</sub> (H) t <sub>h</sub> (L)	Hold Time, HIGH or LOW P <sub>n</sub> to CP	7.0								
t <sub>s</sub> (H) t <sub>s</sub> (L)	Setup Time, HIGH or LOW $\overline{CEP}$ or $\overline{CET}$ to CP	3.0							ns	3-5
t <sub>h</sub> (H) t <sub>h</sub> (L)	Hold Time, HIGH or LOW $\overline{CEP}$ or $\overline{CET}$ to CP	3.0								
t <sub>s</sub> (H) t <sub>s</sub> (L)	Setup Time, HIGH or LOW U/ $\overline{D}$ or $\overline{PE}$ to CP	10							ns	3-5
t <sub>h</sub> (H) t <sub>h</sub> (L)	Hold Time, HIGH or LOW U/ $\overline{D}$ or $\overline{PE}$ to CP	10								
t <sub>w</sub> (H) t <sub>w</sub> (L)	CP Pulse Width, HIGH or LOW	14							ns	3-5
t <sub>w</sub> (H) t <sub>w</sub> (L)	CP Pulse Width, HIGH or LOW	0							ns	3-7
t <sub>w</sub> (H) t <sub>w</sub> (L)	CP Pulse Width, HIGH or LOW	0								

■ Test limits in screened columns are preliminary.

# 54F/74F174

Hex D Flip-Flop  
(With Master Reset)

## Description

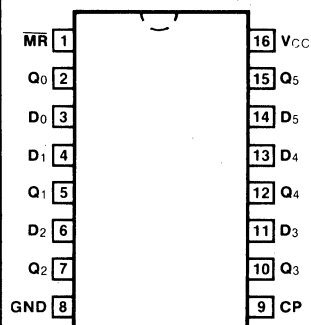
The 'F174 is a high-speed hex D flip-flop. The device is used primarily as a 6-bit edge-triggered storage register. The information on the D inputs is transferred to storage during the LOW-to-HIGH clock transition. The device has a Master Reset to simultaneously clear all flip-flops.

- Edge-Triggered D-Type Inputs
- Buffered Positive Edge-Triggered Clock
- Asynchronous Common Reset

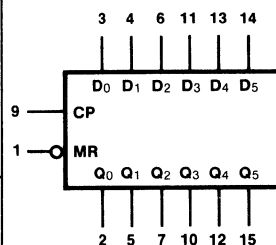
Ordering Code: See Section 6

Pkgs	Commercial Grade	Military Grade	Pkg Type
	$V_{CC} = +5.0\text{ V} \pm 5\%$ , $T_A = 0^\circ\text{C to } +70^\circ\text{C}$	$V_{CC} = +5.0\text{ V} \pm 10\%$ , $T_A = -55^\circ\text{C to } +125^\circ\text{C}$	
Plastic DIP (P)	74F174PC		9B
Ceramic DIP (D)	74F174DC	54F174DM	6B
Flatpak (F)		54F174FM	4L

## Connection Diagram



## Logic Symbol



$V_{CC}$  = Pin 16  
GND = Pin 8

Input Loading/Fan-Out: See Section 3 for U.L. definitions

Pin Names	Description	54F/74F (U.L.) HIGH/LOW
$D_0 - D_5$	Data Inputs	0.5/0.375
CP	Clock Pulse Input (Active Rising Edge)	0.5/0.375
MR	Master Reset Input (Active LOW)	0.5/0.375
$Q_0 - Q_5$	Outputs	25/12.5

## Functional Description

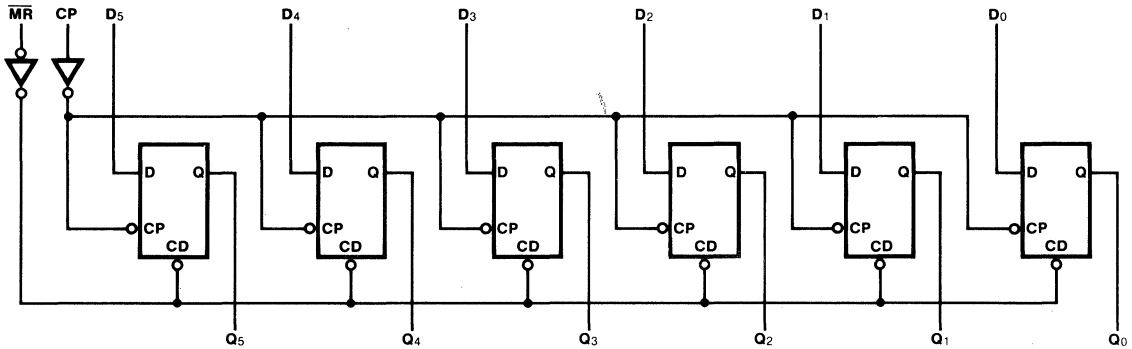
The 'F174 consists of six edge-triggered D flip-flops with individual D inputs and Q outputs. The Clock (CP) and Master Reset ( $\overline{MR}$ ) are common to all flip-flops. Each D input's state is transferred to the corresponding flip-flop's output following the LOW-to-HIGH Clock (CP) transition. A LOW input to the Master Reset ( $\overline{MR}$ ) will force all outputs LOW independent of Clock or Data inputs. The 'F174 is useful for applications where the true output only is required and the Clock and Master Reset are common to all storage elements.

## Truth Table


INPUTS	OUTPUTS
@ $t_n$ , $\overline{MR} = H$	@ $t_{n+1}$
$D_n$	$Q_n$
H	H
L	L

$t_n$  = Bit time before clock pulse  
 $t_{n+1}$  = Bit time after clock pulse  
 H = HIGH Voltage Level  
 L = LOW Voltage Level

## Logic Diagram



**DC Characteristics over Operating Temperature Range** (unless otherwise specified)

Symbol	Parameter	54F/74F			Units	Conditions
		Min	Typ	Max		
I <sub>CC</sub>	Power Supply Current		30	45	mA	V <sub>CC</sub> = Max, D <sub>n</sub> = MR = 4.5 V CP = 

**AC Characteristics:** See Section 3 for waveforms and load configurations

Symbol	Parameter	54F/74F			54F		74F		Units	Fig. No.
		T <sub>A</sub> = +25°C, V <sub>CC</sub> = +5.0 V C <sub>L</sub> = 50 pF			T <sub>A</sub> , V <sub>CC</sub> = Mil C <sub>L</sub> = 50 pF		T <sub>A</sub> , V <sub>CC</sub> = Com C <sub>L</sub> = 50 pF			
		Min	Typ	Max	Min	Max	Min	Max		
f <sub>max</sub>	Maximum Clock Frequency	100	140					MHz	3-1, 3-7	
t <sub>PLH</sub>	Propagation Delay	3.5	5.5	8.0				ns	3-1, 3-7	
t <sub>PHL</sub>	CP to Q <sub>n</sub>	4.5	7.0	10						
t <sub>PHL</sub>	Propagation Delay	5.0	10	14				ns	3-1, 3-11	
	MR to Q <sub>n</sub>									

**AC Operating Requirements:** See Section 3 for waveforms

Symbol	Parameter	54F/74F			54F		74F		Units	Fig. No.
		T <sub>A</sub> = +25°C, V <sub>CC</sub> = +5.0 V			T <sub>A</sub> , V <sub>CC</sub> = Mil		T <sub>A</sub> , V <sub>CC</sub> = Com			
		Min	Typ	Max	Min	Max	Min	Max		
t <sub>s</sub> (H)	Setup Time, HIGH or LOW	4.0						ns	3-5	
t <sub>s</sub> (L)	D <sub>n</sub> to CP	4.0								
t <sub>h</sub> (H)	Hold Time, HIGH or LOW	1.0						ns	3-7	
t <sub>h</sub> (L)	D <sub>n</sub> to CP	1.0								
t <sub>w</sub> (H)	CP Pulse Width, HIGH or LOW	4.0						ns	3-11	
t <sub>w</sub> (L)		5.0								
t <sub>w</sub> (L)	MR Pulse Width LOW	5.0						ns	3-11	
t <sub>rec</sub>	Recovery Time	5.0						ns	3-11	
	MR to CP									

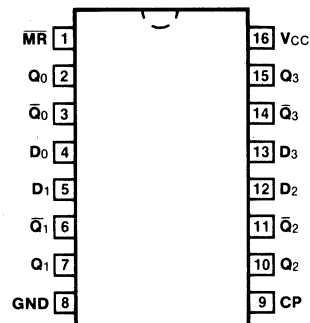
■ Test limits in screened columns are preliminary.



# 54F/74F175

## Quad D Flip-Flop

### Connection Diagram



### Description

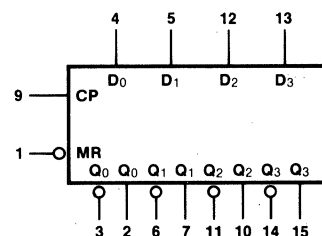
The 'F175 is a high-speed quad D flip-flop. The device is useful for general flip-flop requirements where clock and clear inputs are common. The information on the D inputs is stored during the LOW-to-HIGH clock transition. Both true and complemented outputs of each flip-flop are provided. A Master Reset input resets all flip-flops, independent of the Clock or D inputs, when LOW.

- Edge-triggered D-Type Inputs
- Buffered Positive Edge-triggered Clock
- Asynchronous Common Reset
- True and Complement Output

Ordering Code: See Section 6

Pkgs	Commercial Grade	Military Grade	Pkg Type
	$V_{CC} = +5.0\text{ V} \pm 5\%$ , $T_A = 0^\circ\text{ C to } +70^\circ\text{ C}$	$V_{CC} = +5.0\text{ V} \pm 10\%$ , $T_A = -55^\circ\text{ C to } +125^\circ\text{ C}$	
Plastic DIP (P)	74F175PC		9B
Ceramic DIP (D)	74F175DC	54F175DM	6B
Flatpak (F)		54F175FM	4L

### Logic Symbol



$V_{CC}$  = Pin 16  
GND = Pin 8

Input Loading/Fan-Out: See Section 3 for U.L. definitions

Pin Names	Description	54F/74F (U.L.) HIGH/LOW
$D_0 - D_3$	Data Inputs	0.5/0.375
CP	Clock Pulse Input (Active Rising Edge)	0.5/0.375
$\overline{MR}$	Master Reset Input (Active LOW)	0.5/0.375
$Q_0 - Q_3$	True Outputs	25/12.5
$\overline{Q_0} - \overline{Q_3}$	Complement Outputs	25/12.5

**Functional Description**

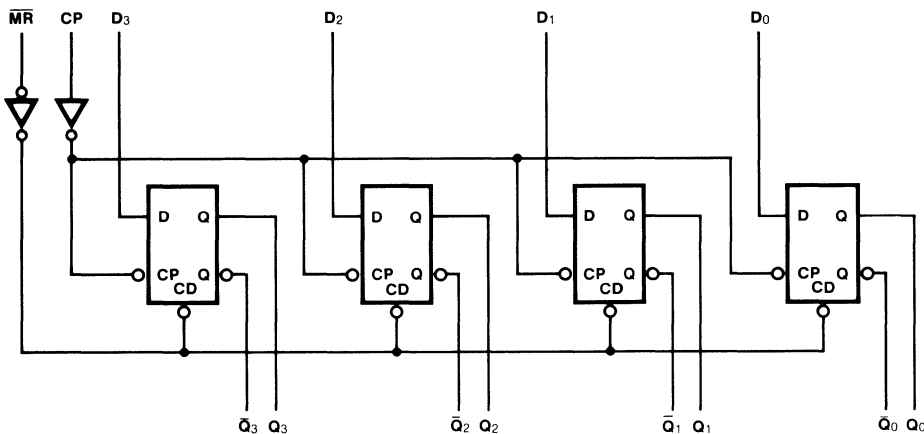
The 'F175 consists of four edge-triggered D flip-flops with individual D inputs and Q and  $\bar{Q}$  outputs. The Clock and Master Reset are common. The four flip-flops will store the state of their individual D inputs on the LOW-to-HIGH clock (CP) transition, causing individual Q and  $\bar{Q}$  outputs to follow. A LOW input on the Master Reset ( $\overline{MR}$ ) will force all Q outputs LOW and  $\bar{Q}$  outputs HIGH independent of Clock or Data inputs. The 'F175 is useful for general logic applications where a common Master Reset and Clock are acceptable.

**Truth Table**

INPUTS		OUTPUTS	
@ $t_n, \overline{MR} = H$		@ $t_{n+1}$	
$D_n$		$Q_n$	$\bar{Q}_n$
L		L	H
H		H	L

$t_n$  = Bit time before clock positive-going transition  
 $t_{n+1}$  = Bit time after clock positive-going transition  
 H = HIGH Voltage Level  
 L = LOW Voltage Level

**Logic Diagram**



Please note that this diagram is provided only for the understanding of logic operations and should not be used to estimate propagation delays.

**DC Characteristics over Operating Temperature Range** (unless otherwise specified)

Symbol	Parameter	54F/74F			Units	Conditions
		Min	Typ	Max		
I <sub>CC</sub>	Power Supply Current		22.5	34	mA	V <sub>CC</sub> = Max D <sub>n</sub> = $\overline{MR}$ = 4.5 V CP = $\overline{J}$

**AC Characteristics:** See Section 3 for waveforms and load configurations

Symbol	Parameter	54F/74F			54F		74F		Units	Fig. No.
		T <sub>A</sub> = +25°C, V <sub>CC</sub> = +5.0 V C <sub>L</sub> = 50 pF			T <sub>A</sub> , V <sub>CC</sub> = Mil C <sub>L</sub> = 50 pF		T <sub>A</sub> , V <sub>CC</sub> = Com C <sub>L</sub> = 50 pF			
		Min	Typ	Max	Min	Max	Min	Max		
f <sub>max</sub>	Maximum Clock Frequency	100	140		100		100	MHz	3-1, 3-7	
t <sub>PLH</sub> t <sub>PHL</sub>	Propagation Delay CP to Q <sub>n</sub> or $\overline{Q}_n$	4.0	5.0	6.5	3.5	8.5	4.0	7.5	ns	3-1 3-7
t <sub>PHL</sub>	Propagation Delay $\overline{MR}$ to Q <sub>n</sub>	4.5	9.0	11.5	4.5	15	4.5	13	ns	3-1 3-11
t <sub>PLH</sub>	Propagation Delay MR to Q <sub>n</sub>	4.0	6.5	8.0	4.0	10	4.0	9.0	ns	3-1 3-11

**AC Operating Requirements:** See Section 3 for waveforms

Symbol	Parameter	54F/74F			54F		74F		Units	Fig. No.
		T <sub>A</sub> = +25°C, V <sub>CC</sub> = +5.0 V			T <sub>A</sub> , V <sub>CC</sub> = Mil		T <sub>A</sub> , V <sub>CC</sub> = Com			
		Min	Typ	Max	Min	Max	Min	Max		
t <sub>s</sub> (H) t <sub>s</sub> (L)	Setup Time, HIGH or LOW D <sub>n</sub> to CP	3.0			3.0		3.0		ns	3-5
t <sub>h</sub> (H) t <sub>h</sub> (L)	Hold Time, HIGH or LOW D <sub>n</sub> to CP	1.0			1.0		1.0			
t <sub>w</sub> (H) t <sub>w</sub> (L)	CP Pulse Width HIGH or LOW	4.0			4.0		4.0		ns	3-7
t <sub>w</sub> (L)	$\overline{MR}$ Pulse Width LOW	5.0			5.0		5.0		ns	3-11
t <sub>rec</sub>	Recovery Time $\overline{MR}$ to CP	5.0			5.0		5.0		ns	3-11

# 54F/74F181

## 4-Bit Arithmetic Logic Unit

### Description

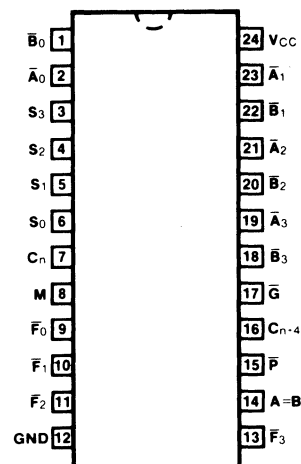
The 'F181 is a 4-bit Arithmetic Logic Unit (ALU) which can perform all the possible 16 logic operations on two variables and a variety of arithmetic operations. It is 40% faster than the Schottky ALU and only consumes 30% as much power.

- Provides 16 Arithmetic Operations  
Add, Subtract, Compare, Double, Plus Twelve other Arithmetic Operations
- Provides All 16 Logic Operations of Two Variables  
Exclusive-OR, Compare, AND, NAND, OR, NOR, Plus Ten Other Logic Operations
- Full Lookahead for High-speed Arithmetic Operation on Long Words

Ordering Code: See Section 6

Pkgs	Commercial Grade	Military Grade	Pkg Type
	V <sub>CC</sub> = +5.0 V ±5%, T <sub>A</sub> = 0° C to +70° C	V <sub>CC</sub> = +5.0 V ±10%, T <sub>A</sub> = -55° C to +125° C	
Plastic DIP (P)	74F181PC		9N
Ceramic DIP (D)	74F181DC	54F181DM	6N
Flatpak (F)		54F181FM	4M

### Connection Diagram



4

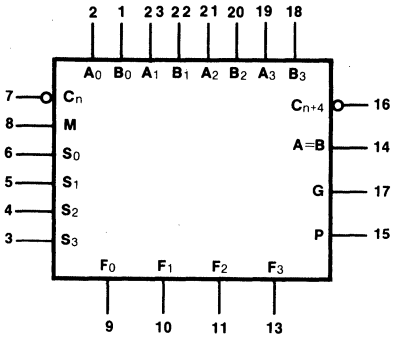
Input Loading/Fan-Out: See Section 3 for U.L. definitions

Pin Names	Description	54F/74F (U.L.) HIGH/LOW
$\bar{A}_0 - \bar{A}_3$	A Operand Inputs (Active LOW)	0.5/1.125
$\bar{B}_0 - \bar{B}_3$	B Operand Inputs (Active LOW)	0.5/1.125
$S_0 - S_3$	Function Select Inputs	0.5/1.50
M	Mode Control Input	0.5/0.375
$C_n$	Carry Input	0.5/1.875
$\bar{F}_0 - \bar{F}_3$	Function Outputs (Active LOW)	25/12.5
A = B	Comparator Output	OC*/12.5
$\bar{G}$	Carry Generate Output (Active LOW)	25/12.5
$\bar{P}$	Carry Propagate Output (Active LOW)	25/12.5
$C_{n+4}$	Carry Output	25/12.5

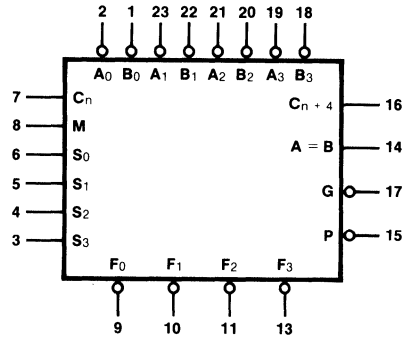
\*OC— Open Collector

## Logic Symbols

### Active-HIGH Operands

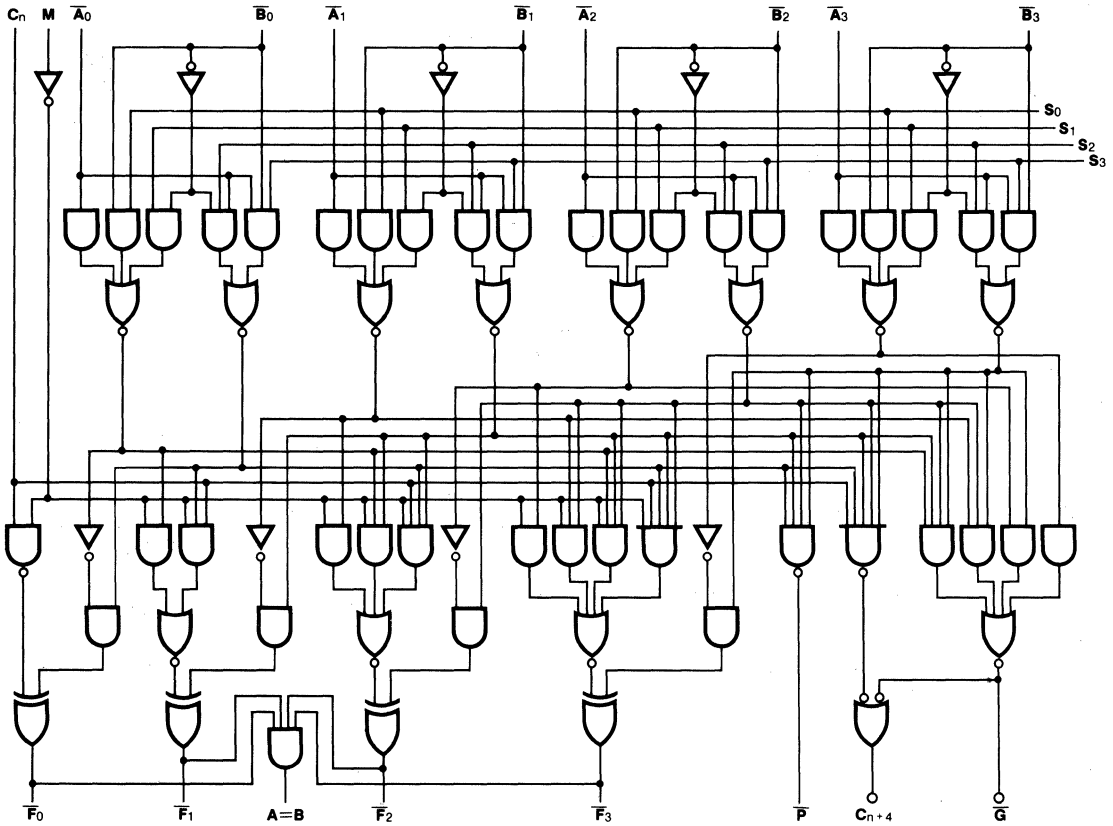


### Active-LOW Operands



VCC = Pin 24  
GND = Pin 12

## Logic Diagram



### Functional Description

The 'F181 is a 4-bit high-speed parallel Arithmetic Logic Unit (ALU). Controlled by the four Function Select inputs ( $S_0 - S_3$ ) and the Mode Control input (M), it can perform all the 16 possible logic operations or 16 different arithmetic operations on active-HIGH or active-LOW operands. The Function Table lists these operations.

When the Mode Control input (M) is HIGH, all internal carries are inhibited and the device performs logic operations on the individual bits as listed. When the Mode Control input is LOW, the carries are enabled and the device performs arithmetic operations on the two 4-bit words. The device incorporates full internal carry lookahead and provides for either ripple carry between devices using the  $C_{n+4}$  output, or for carry lookahead between packages using the signals  $\overline{P}$  (Carry Propagate) and  $\overline{G}$  (Carry Generate). In the Add mode,  $\overline{P}$  indicates that  $\overline{F}$  is 15 or more, while  $\overline{G}$  indicates that  $\overline{F}$  is 16 or more. In the Subtract mode,  $\overline{P}$  indicates that  $\overline{F}$  is zero or less, while  $\overline{G}$  indicates that  $\overline{F}$  is less than zero.  $\overline{P}$  and  $\overline{G}$  are not affected by carry in. When speed requirements are not stringent, it can be used in a simple Ripple Carry mode by connecting the Carry output ( $C_{n+4}$ ) signal to the Carry input ( $C_n$ ) of the next unit. For high-speed operation the device is used in conjunction with a carry lookahead circuit. One carry lookahead package is required for each group of four 'F181

devices. Carry lookahead can be provided at various levels and offers high speed capability over extremely long word lengths.

The  $A = B$  output from the device goes HIGH when all four  $\overline{F}$  outputs are HIGH and can be used to indicate logic equivalence over four bits when the unit is in the Subtract mode. The  $A = B$  output is open collector and can be wired-AND with other  $A = B$  outputs to give a comparison for more than four bits. The  $A = B$  signal can also be used with the  $C_{n+4}$  signal to indicate  $A > B$  and  $A < B$ .

The Function Table lists the arithmetic operations that are performed without a carry in. An incoming carry adds a one to each operation. Thus, select code LHHH generates A minus B minus 1 (2s complement notation) without a carry in and generates A minus B when a carry is applied. Because subtraction is actually performed by complementary addition (1s complement), a carry out means borrow; thus a carry is generated when there is no underflow and no carry is generated when there is underflow. As indicated, this device can be used with either active-LOW inputs producing active-LOW outputs or with active-HIGH inputs producing active-HIGH outputs. For either case the table lists the operations that are performed to the operands labeled inside the logic symbol.

Function Table

MODE SELECT INPUTS				ACTIVE-LOW OPERANDS & $F_n$ OUTPUTS		ACTIVE-HIGH OPERANDS & $F_n$ OUTPUTS	
$S_3$	$S_2$	$S_1$	$S_0$	LOGIC (M = H)	ARITHMETIC** (M = L) ( $C_n = L$ )	LOGIC (M = H)	ARITHMETIC** (M = L) ( $C_n = H$ )
L	L	L	L	$\overline{A}$	A minus 1	$\overline{A}$	A
L	L	L	H	$\overline{A}\overline{B}$	$\overline{A}\overline{B}$ minus 1	$\overline{A + B}$	$A + B$
L	L	H	L	$\overline{A} + \overline{B}$	$\overline{A} + \overline{B}$ minus 1	$\overline{A}\overline{B}$	$A + \overline{B}$
L	L	H	H	Logic 1	minus 1	Logic 0	minus 1
L	H	L	L	$\overline{A + B}$	A plus ( $A + \overline{B}$ )	$\overline{A}\overline{B}$	A plus $\overline{A}\overline{B}$
L	H	L	H	$\overline{B}$	$\overline{B}$ plus ( $A + \overline{B}$ )	$\overline{B}$	( $A + B$ ) plus $\overline{A}\overline{B}$
L	H	H	L	$A \oplus \overline{B}$	A minus B minus 1	$A \oplus B$	A minus B minus 1
L	H	H	H	$A + \overline{B}$	$A + \overline{B}$	$\overline{A}\overline{B}$	$\overline{A}\overline{B}$ minus 1
H	L	L	L	$\overline{A}\overline{B}$	A plus ( $A + B$ )	$\overline{A + B}$	A plus AB
H	L	L	H	$A \oplus B$	A plus B	$A \oplus B$	A plus B
H	L	H	L	B	$\overline{A}\overline{B}$ plus ( $A + B$ )	B	( $A + \overline{B}$ ) plus AB
H	L	H	H	$A + B$	$A + B$	AB	AB minus 1
H	H	L	L	Logic 0	A plus $A^*$	Logic 1	A plus $A^*$
H	H	L	H	$\overline{A}\overline{B}$	$\overline{A}\overline{B}$ plus A	$A + \overline{B}$	( $A + B$ ) plus A
H	H	H	L	AB	$\overline{A}\overline{B}$ minus A	$A + B$	( $A + \overline{B}$ ) plus A
H	H	H	H	A	A	A	A minus 1

\*each bit is shifted to the next more significant position

\*\*arithmetic operations expressed in 2s complement notation

H = HIGH Voltage Level

L = LOW Voltage Level

## DC Characteristics Over Operating Temperature Range (unless otherwise specified)

Symbol	Parameter	54F/74F			Units	Conditions
		Min	Typ	Max		
I <sub>OH</sub>	Output HIGH Current			250	μA	V <sub>OH</sub> = 4.5 V, V <sub>CC</sub> = Min, A = B
I <sub>CC</sub>	Power Supply Current		43	65	mA	V <sub>CC</sub> = Max

## AC Characteristics: See Section 3 for waveforms and load configurations

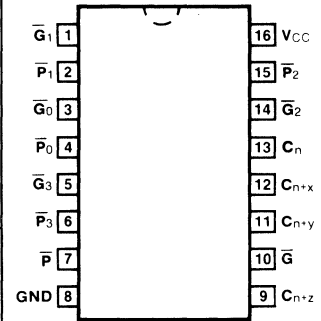
Symbol	Parameter	Path	Mode	54F/74F			54F		74F		Units	Fig. No.
				T <sub>A</sub> = +25°C, V <sub>CC</sub> = +5.0 V C <sub>L</sub> = 50 pF			T <sub>A</sub> , V <sub>CC</sub> = Mil C <sub>L</sub> = 50 pF		T <sub>A</sub> , V <sub>CC</sub> = Com C <sub>L</sub> = 50 pF			
				Min	Typ	Max	Min	Max	Min	Max		
t <sub>PLH</sub> t <sub>PHL</sub>	C <sub>n</sub> to C <sub>n+4</sub>			3.0 3.0	6.4 6.1	8.5 8.0	3.0 3.0	12 11.5	3.0 3.0	9.5 9.0	ns	3-1 3-4
t <sub>PLH</sub> t <sub>PHL</sub>	$\bar{A}$ or $\bar{B}$ to C <sub>n+4</sub>		Sum	7.0 7.0	10 9.4	13 12	7.0 7.0	18 17	7.0 7.0	14 13	ns	3-1 3-3
t <sub>PLH</sub> t <sub>PHL</sub>	$\bar{A}$ or $\bar{B}$ to C <sub>n+4</sub>		Dif	7.0 7.0	10.8 10	14 13	7.0 7.0	19.5 18	7.0 7.0	15 14	ns	3-1 3-3
t <sub>PLH</sub> t <sub>PHL</sub>	C <sub>n</sub> to $\bar{F}$		Any	3.0 3.0	6.7 6.5	8.5 8.5	3.0 3.0	12 12	3.0 3.0	9.5 9.5	ns	3-1 3-4
t <sub>PLH</sub> t <sub>PHL</sub>	$\bar{A}$ or $\bar{B}$ to $\bar{G}$		Sum	3.0 3.0	5.7 5.8	7.5 7.5	3.0 3.0	10.5 10.5	3.0 3.0	8.5 8.5	ns	3-4 3-4
t <sub>PLH</sub> t <sub>PHL</sub>	$\bar{A}$ or $\bar{B}$ to $\bar{G}$		Dif	3.0 3.0	6.5 7.3	8.5 9.5	3.0 3.0	12 13.5	3.0 3.0	9.5 10.5	ns	3-1 3-3
t <sub>PLH</sub> t <sub>PHL</sub>	$\bar{A}$ or $\bar{B}$ to $\bar{P}$		Sum	3.0 3.0	5.0 5.5	7.0 7.5	3.0 3.0	10 10.5	3.0 3.0	8.0 8.5	ns	3-1 3-3
t <sub>PLH</sub> t <sub>PHL</sub>	$\bar{A}$ or $\bar{B}$ to $\bar{P}$		Dif	4.0 4.0	5.8 6.5	7.5 8.5	4.0 4.0	10.5 12	4.0 4.0	8.5 9.5	ns	3-1 3-3
t <sub>PLH</sub> t <sub>PHL</sub>	$\bar{A}_i$ to $\bar{B}_i$ to $\bar{F}_i$		Sum	4.0 4.0	7.0 7.2	9.0 10	4.0 4.0	12.5 14	4.0 4.0	10 10	ns	3-1, 3-3 3-4
t <sub>PLH</sub> t <sub>PHL</sub>	$\bar{A}_i$ or $\bar{B}_i$ to $\bar{F}_i$		Dif	4.5 4.5	8.2 5.0	11 11	4.5 4.5	15.5 15.5	4.5 4.5	12 12	ns	3-1, 3-3 3-4
t <sub>PLH</sub> t <sub>PHL</sub>	Any $\bar{A}$ or $\bar{B}$ to Any $\bar{F}$		Sum	4.0 4.0	8.0 7.8	10.5 10	4.0 4.0	15.5 14	4.0 4.0	11.5 11	ns	3-1, 3-3 3-4
t <sub>PLH</sub> t <sub>PHL</sub>	Any $\bar{A}$ or $\bar{B}$ to Any $\bar{F}$		Dif	4.5 4.5	9.4 9.4	12 12	4.5 4.5	17 17	4.5 4.5	13 13	ns	3-1, 3-3 3-4
t <sub>PLH</sub> t <sub>PHL</sub>	$\bar{A}$ or $\bar{B}$ to $\bar{F}$		Logic	4.0 4.0	6.0 6.0	9.0 10	4.0 4.0	12.5 14	4.0 4.0	10 11	ns	3-1, 3-3 3-4
t <sub>PLH</sub> t <sub>PHL</sub>	$\bar{A}$ or $\bar{B}$ to A = B		Dif	11 7.0	18.5 9.8	27 12.5	11 7.0	35 17.5	11 7.0	29 13.5	ns	3-1, 3-3 3-4

■ Test limits in screened columns are preliminary.

# 54F/74F182

## Carry Lookahead Generator

### Connection Diagram



### Description

The 'F182 is a high-speed carry lookahead generator. It is generally used with the 'F181, 'F381 or 29F01 4-bit arithmetic logic unit to provide high-speed lookahead over word lengths of more than four bits.

- Provides Lookahead Carries across a Group of Four ALUs
- Multi-level Lookahead High-speed Arithmetic Operation over Long Word Lengths

Ordering Code: See Section 6

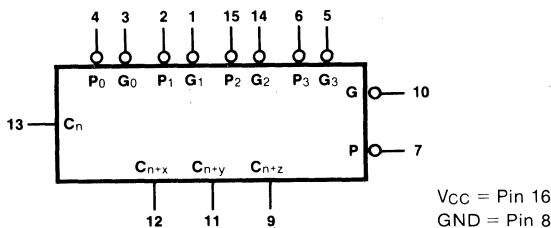
Pkgs	Commercial Grade	Military Grade	Pkg Type
	$V_{CC} = +5.0\text{ V} \pm 5\%$ , $T_A = 0^\circ\text{C to } +70^\circ\text{C}$	$V_{CC} = +5.0\text{ V} \pm 10\%$ , $T_A = -55^\circ\text{C to } +125^\circ\text{C}$	
Plastic DIP (P)	74F182PC		9B
Ceramic DIP (D)	74F182DC	54F182DM	7B
Flatpak (F)		54F182FM	4L

4

Input Loading/Fan-Out: See Section 3 for U.L. definitions

Pin Names	Description	54F/74F (U.L.) HIGH/LOW
$C_n$	Carry Input	0.5/0.75
$\overline{G}_0, \overline{G}_2$	Carry Generate Inputs (Active LOW)	0.5/5.25
$\overline{G}_1$	Carry Generate Input (Active LOW)	0.5/6.0
$\overline{G}_3$	Carry Generate Input (Active LOW)	0.5/3.0
$\overline{P}_0, \overline{P}_1$	Carry Propagate Inputs (Active LOW)	0.5/3.0
$\overline{P}_2$	Carry Propagate Input (Active LOW)	0.5/2.25
$\overline{P}_3$	Carry Propagate Input (Active LOW)	0.5/1.5
$C_{n+x} - C_{n+z}$	Carry Outputs	25/12.5
$\overline{G}$	Carry Generate Output (Active LOW)	25/12.5
$\overline{P}$	Carry Propagate Output (Active LOW)	25/12.5

### Logic Symbol





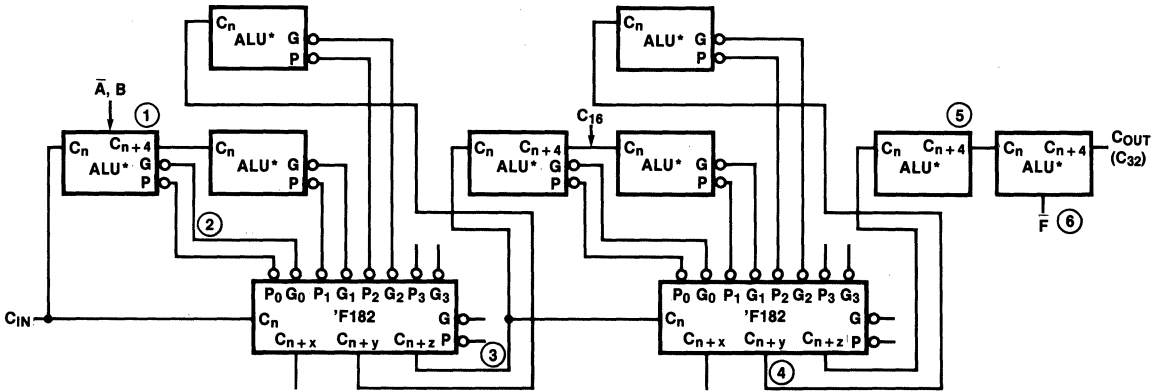
## Functional Description

The 'F182 carry lookahead generator accepts up to four pairs of active-LOW Carry Propagate ( $\bar{P}_0 - \bar{P}_3$ ) and Carry Generate ( $\bar{G}_0 - \bar{G}_3$ ) signals and an active-HIGH Carry input ( $C_n$ ) and provides anticipated active-HIGH carries ( $C_{n+x}, C_{n+y}, C_{n+z}$ ) across four groups of binary adders. The 'F182 also has active-LOW Carry Propagate ( $\bar{P}$ ) and Carry Generate ( $\bar{G}$ ) outputs which may be used for further levels of look-ahead. The logic equations provided at the outputs are:

$$\begin{aligned}
 C_{n+x} &= G_0 + P_0 C_n \\
 C_{n+y} &= G_1 + P_1 G_0 + P_1 P_0 C_n \\
 C_{n+z} &= G_2 + P_2 G_1 + P_2 P_1 G_0 + P_2 P_1 P_0 C_n \\
 G &= \bar{G}_3 + P_3 \bar{G}_2 + P_3 P_2 \bar{G}_1 + P_3 P_2 P_1 \bar{G}_0 \\
 P &= P_3 P_2 P_1 P_0
 \end{aligned}$$

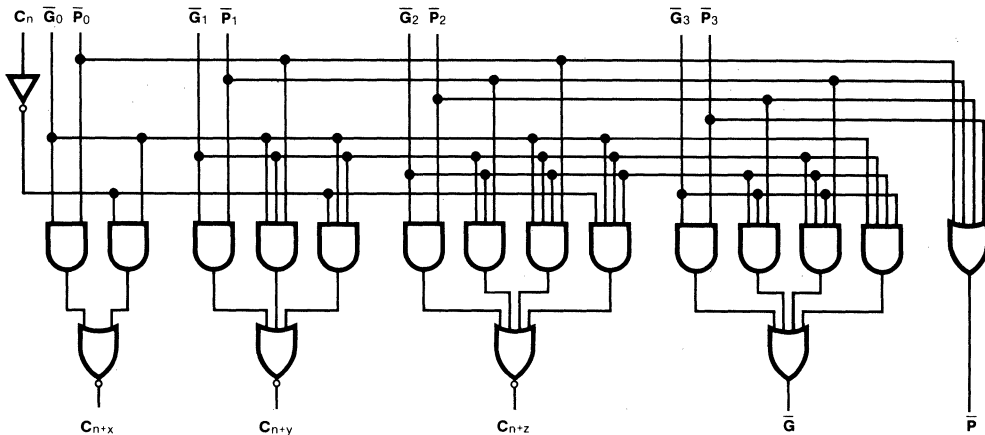
Also, the 'F182 can be used with binary ALU's in an active-LOW or active-HIGH input operand mode. The connections (*Figure a*) to and from the ALU to the carry lookahead generator are identical in both cases. Carries are rippled between lookahead blocks. The critical speed path follows the circled numbers. There are several possible arrangements for the carry interconnects, but all achieve about the same speed. A 28-bit ALU is formed by dropping the last 'F181 or 'F381.

Fig. a 32-Bit ALU with Ripple Carry between 16-Bit Lookahead ALUs



\*ALUs may be either 'F181, 'F381 or 2901A

## Logic Diagram



Truth Table

INPUTS										OUTPUTS				
C <sub>n</sub>	$\bar{G}_0$	$\bar{P}_0$	$\bar{G}_1$	$\bar{P}_1$	$\bar{G}_2$	$\bar{P}_2$	$\bar{G}_3$	$\bar{P}_3$	C <sub>n+x</sub>	C <sub>n+y</sub>	C <sub>n+z</sub>	$\bar{G}$	$\bar{P}$	
X	H	H							L					
L	H	X							L					
X	L	X							L					
H	X	L							H					
X	X	X	H	H						L				
X	H	H	H	X						L				
L	H	X	H	X						L				
X	X	X	L	X						L				
X	L	X	X	L						H				
H	X	L	X	L						H				
X	X	X	X	X	H	H					L			
X	X	X	H	H	H	X					L			
X	H	H	H	X	H	X					L			
L	H	X	H	X	H	X					L			
X	X	X	X	X	L	X					H			
X	X	X	L	X	X	L					H			
X	L	X	X	L	X	L					H			
H	X	L	X	L	X	L					H			
			X	X	X	H	H					H		
			X	X	H	H	X					H		
			X	X	H	X	H	X				H		
			X	X	X	X	L	X				L		
			X	X	L	X	X	L				L		
			L	X	X	L	X	L				L		
			X	L	X	L	X	L				L		
		H		X		X		X					H	
		X		H		X		X					H	
		X		X		H		X					H	
		X		X		X		H					H	
		L		L		L		L					L	

H = HIGH Voltage Level  
 L = LOW Voltage Level  
 X = Immaterial

## DC Characteristics over Operating Temperature Range (unless otherwise specified)

Symbol	Parameter	54F/74F			Units	Conditions
		Min	Typ	Max		
I <sub>CC</sub> H	Power Supply Current (All Outputs HIGH)		18.4	28	mA	V <sub>CC</sub> = Max; $\overline{P}_3, \overline{G}_3 = 4.5$ V All Other Inputs = Gnd
I <sub>CC</sub> L	Power Supply Current (All Outputs LOW)		23.5	36	mA	V <sub>CC</sub> = Max; $\overline{G}_0, \overline{G}_1, \overline{G}_2 = 4.5$ V All Other Inputs = Gnd

## AC Characteristics: See Section 3 for waveforms and load configurations

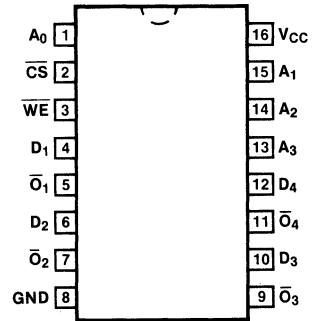
Symbol	Parameter	54F/74F			54F		74F		Units	Fig. No.
		T <sub>A</sub> = +25°C, V <sub>CC</sub> = +5.0 V C <sub>L</sub> = 50 pF			T <sub>A</sub> , V <sub>CC</sub> = Mil C <sub>L</sub> = 50 pF		T <sub>A</sub> , V <sub>CC</sub> = Com C <sub>L</sub> = 50 pF			
		Min	Typ	Max	Min	Max	Min	Max		
t <sub>PLH</sub> t <sub>PHL</sub>	Propagation Delay C <sub>n</sub> to C <sub>n+x</sub> , C <sub>n+y</sub> , C <sub>n+z</sub>	3.0 3.0	6.6 6.8	8.5 9.0	3.0 3.0	10.5 11	3.0 3.0	9.5 10	ns	3-1 3-4
t <sub>PLH</sub> t <sub>PHL</sub>	Propagation Delay $\overline{P}_0, \overline{P}_1$ or $\overline{P}_2$ to C <sub>n+x</sub> , C <sub>n+y</sub> , C <sub>n+z</sub>	2.5 2.0	6.2 3.7	8.0 5.0	2.5 2.0	10.7 6.5	2.5 2.0	9.0 6.0	ns	3-1 3-3
t <sub>PLH</sub> t <sub>PHL</sub>	Propagation Delay $\overline{G}_0, \overline{G}_1$ or $\overline{G}_2$ to C <sub>n+x</sub> , C <sub>n+y</sub> , C <sub>n+z</sub>	2.5 2.0	6.5 3.9	8.5 5.2	2.5 2.0	10.5 6.5	2.5 2.0	9.5 6.0	ns	3-1 3-3
t <sub>PLH</sub> t <sub>PHL</sub>	Propagation Delay $\overline{P}_1, \overline{P}_2$ or $\overline{P}_3$ to $\overline{G}$	3.0 3.0	7.9 6.0	10.0 8.0	3.0 3.0	12.5 9.5	3.0 3.0	11 9.0	ns	3-1 3-4
t <sub>PLH</sub> t <sub>PHL</sub>	Propagation Delay $\overline{G}_n$ to $\overline{G}$	3.0 3.0	8.3 5.7	10.5 7.5	3.0 3.0	12.5 9.5	3.0 3.0	11.5 8.5	ns	3-1 3-4
t <sub>PLH</sub> t <sub>PHL</sub>	Propagation Delay $\overline{P}_n$ to $\overline{P}$	3.0 2.5	5.7 4.1	7.5 5.5	3.0 2.5	11 7.5	3.0 2.5	8.5 6.5	ns	3-1 3-4

■ Test limits in screened columns are preliminary.

# 54F/74F189

64-Bit Random Access Memory  
(With 3-State Outputs)

## Connection Diagram



### Description

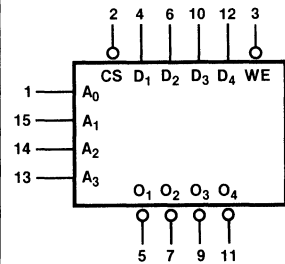
The 'F189 is a high-speed 64-bit RAM organized as a 16-word by 4-bit array. Address inputs are buffered to minimize loading and are fully decoded on-chip. The outputs are 3-state and are in the high-impedance state whenever the Chip Select ( $\overline{CS}$ ) input is HIGH. The outputs are active only in the Read mode and the output data is the complement of the stored data.

- 3-State Outputs for Data Bus Applications
- Buffered Inputs Minimize Loading
- Address Decoding On-chip
- Diode Clamped Inputs Minimize Ringing

Ordering Code: See Section 6

Pkgs	Commercial Grade	Military Grade	Pkg Type
	$V_{CC} = +5.0\text{ V} \pm 5\%$ , $T_A = 0^\circ\text{C to } +70^\circ\text{C}$	$V_{CC} = +5.0\text{ V} \pm 10\%$ , $T_A = -55^\circ\text{C to } +125^\circ\text{C}$	
Plastic DIP (P)	74F189PC		9B
Ceramic DIP (D)	74F189DC	54F189DM	6B
Flatpak (F)		54F189FM	4L

### Logic Symbol



$V_{CC}$  = Pin 16  
GND = Pin 8

Input Loading/Fan-Out: See Section 3 for U.L. definitions

Pin Names	Description	54F/74F (U.L.) HIGH/LOW
$A_0 - A_3$	Address Inputs	0.5/0.375
$\overline{CS}$	Chip Select Input (Active LOW)	0.5/0.75
$\overline{WE}$	Write Enable Input (Active LOW)	0.5/0.75
$D_1 - D_4$	Data Inputs	0.5/0.375
$\overline{O}_1 - \overline{O}_4$	Inverted Data Outputs	25/12.5

## Function Table

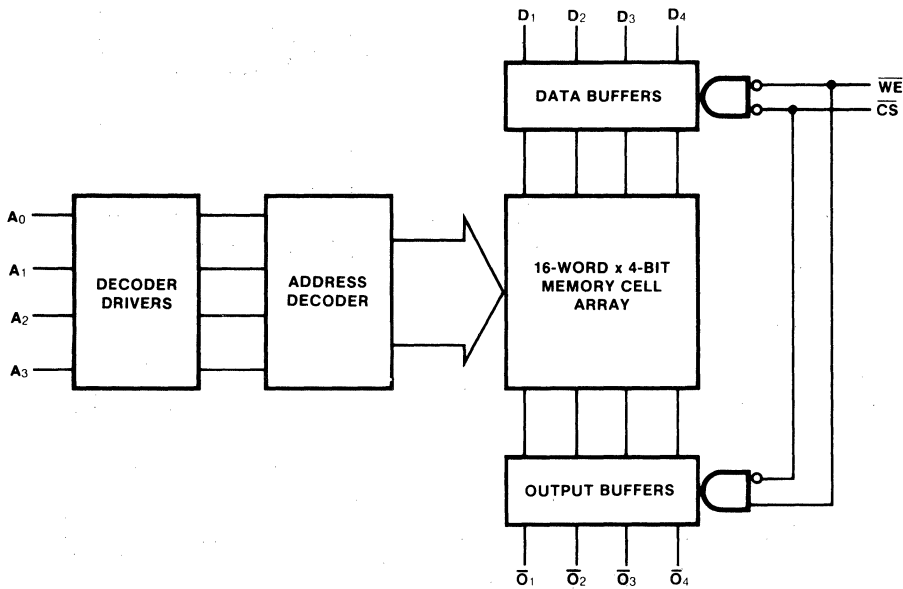
INPUTS		OPERATION	CONDITION OF OUTPUTS
$\overline{CS}$	WE		
L	L	Write	High Impedance
L	H	Read	Complement of Stored Data
H	X	Inhibit	High Impedance

H = HIGH Voltage Level

L = LOW Voltage Level

X = Immaterial

## Logic Diagram



**DC Characteristics over Operating Temperature Range** (unless otherwise specified)

Symbol	Parameter	54F/74F			Units	Conditions
		Min	Typ	Max		
I <sub>CC</sub>	Power Supply Current		37	55	mA	V <sub>CC</sub> = Max; $\overline{WE}$ , $\overline{CS}$ , Gnd

**AC Characteristics:** See Section 3 for waveforms and load configurations

Symbol	Parameter	54F/74F			54F		74F		Units	Fig. No.
		T <sub>A</sub> = +25°C, V <sub>CC</sub> = +5.0 V, C <sub>L</sub> = 50 pF			T <sub>A</sub> , V <sub>CC</sub> = Mil, C <sub>L</sub> = 50 pF		T <sub>A</sub> , V <sub>CC</sub> = Com, C <sub>L</sub> = 50 pF			
		Min	Typ	Max	Min	Max	Min	Max		
t <sub>PLH</sub> t <sub>PHL</sub>	Access Time, HIGH or LOW A <sub>n</sub> to $\overline{O}_n$	8.0	12	15.5	8.0	22	8.0	18	ns	3-1 3-10
t <sub>PZH</sub> t <sub>PZL</sub>	Access Time, HIGH or LOW $\overline{CS}$ to $\overline{O}_n$	3.5	5.0	6.5	3.5	9.0	3.5	7.5	ns	3-1, 3-12 3-13
t <sub>PHZ</sub> t <sub>PLZ</sub>	Disable Time, HIGH or LOW $\overline{CS}$ to $\overline{O}_n$	2.0	3.5	4.7	2.5	7.0	2.0	5.5	ns	3-1, 3-12 3-13
t <sub>PZH</sub> t <sub>PZL</sub>	Write Recovery Time, HIGH or LOW $\overline{WE}$ to $\overline{O}_n$	9.0	13.5	17	9.0	24	9.0	19.5	ns	3-1, 3-12 3-13
t <sub>PHZ</sub> t <sub>PLZ</sub>	Disable Time, HIGH or LOW $\overline{WE}$ to $\overline{O}_n$	3.5	5.0	6.5	3.5	9.0	3.5	7.5	ns	3-1, 3-12 3-13

**AC Operating Requirements:** See Section 3 for waveforms

Symbol	Parameter	54F/74F			54F		74F		Units	Fig. No.
		T <sub>A</sub> = +25°C, V <sub>CC</sub> = +5.0 V			T <sub>A</sub> , V <sub>CC</sub> = Mil		T <sub>A</sub> , V <sub>CC</sub> = Com			
		Min	Typ	Max	Min	Max	Min	Max		
t <sub>s</sub> (H) t <sub>s</sub> (L)	Setup Time, HIGH or LOW A <sub>n</sub> to $\overline{WE}$	0			0		0		ns	3-16
t <sub>h</sub> (H) t <sub>h</sub> (L)	Hold Time, HIGH or LOW A <sub>n</sub> to $\overline{WE}$	0			0		0			
t <sub>s</sub> (H) t <sub>s</sub> (L)	Setup Time, HIGH or LOW D <sub>n</sub> to $\overline{WE}$	10			10		10		ns	3-14
t <sub>h</sub> (H) t <sub>h</sub> (L)	Hold Time, HIGH or LOW D <sub>n</sub> to $\overline{WE}$	0			0		0			
t <sub>s</sub> (L)	Setup Time LOW $\overline{CS}$ to $\overline{WE}$	6.0			6.0		6.0		ns	3-14
t <sub>h</sub> (L)	Hold Time, LOW $\overline{CS}$ to $\overline{WE}$	0			0		0			
t <sub>w</sub> (L)	$\overline{WE}$ Pulse Width LOW	6.0			6.0		6.0		ns	3-16

■ Test limits in screened columns are preliminary.

# 54F/74F190

Up/Down Decade Counter  
(With Preset and Ripple Clock)

## Description

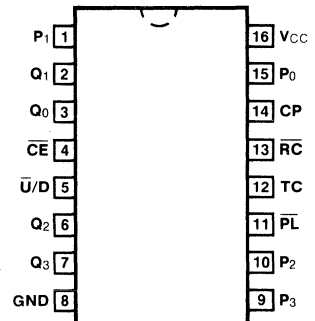
The 'F190 is a reversible BCD (8421) decade counter featuring synchronous counting and asynchronous presetting. The preset feature allows the 'F190 to be used in programmable dividers. The Count Enable input, the Terminal Count output and the Ripple Clock output make possible a variety of methods of implementing multistage counters. In the counting modes, state changes are initiated by the rising edge of the clock.

- **High-speed** — 110 MHz Typical Count Frequency
- **Synchronous Counting**
- **Asynchronous Parallel Load**
- **Cascadable**

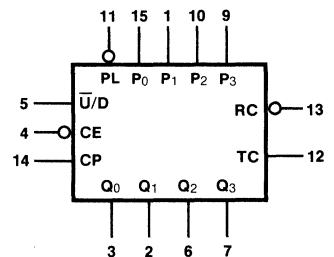
**Ordering Code:** See Section 6

Pkgs	Commercial Grade	Military Grade	Pkg Type
	V <sub>CC</sub> = +5.0 V ±5%, T <sub>A</sub> = 0° C to +70° C	V <sub>CC</sub> = +5.0 V ±10%, T <sub>A</sub> = -55° C to +125° C	
Plastic DIP (P)	74F190PC		9B
Ceramic DIP (D)	74F190DC	54F190DM	7B
Flatpak (F)		54F190FM	4L

## Connection Diagram



## Logic Symbol



V<sub>CC</sub> = Pin 16  
GND = Pin 8

**Input Loading/Fan-Out:** See Section 3 for U.L. definitions

Pin Names	Description	54F/74F (U.L.) HIGH/LOW
CE	Count Enable Input (Active LOW)	0.5/1.125
CP	Clock Pulse Input (Active Rising Edge)	0.5/0.375
P <sub>0</sub> - P <sub>0</sub>	Parallel Data Inputs	0.5/0.375
PL	Asynchronous Parallel Load Input (Active LOW)	0.5/0.375
U/D	Up/Down Count Control Input	0.5/0.375
Q <sub>0</sub> - Q <sub>3</sub>	Flip-flop Outputs	25/12.5
RC	Ripple Clock Output (Active LOW)	25/12.5
TC	Terminal Count Output (Active HIGH)	25/12.5





## Functional Description

The 'F190 is a synchronous up/down BCD decade counter containing four edge-triggered flip-flops, with internal gating and steering logic to provide individual preset, count-up and count-down operations. It has an asynchronous parallel load capability permitting the counter to be preset to any desired number. When the Parallel Load ( $\overline{PL}$ ) input is LOW, information present on the Parallel Data inputs ( $P_0 - P_3$ ) is loaded into the counter and appears on the Q outputs. This operation overrides the counting functions, as indicated in the Mode Select Table. A HIGH signal on the  $\overline{CE}$  input inhibits counting. When  $\overline{CE}$  is LOW, internal state changes are initiated synchronously by the LOW-to-HIGH transition of the clock input. The direction of counting is determined by the  $\overline{U/D}$  input signal, as indicated in the Mode Select Table.  $\overline{CE}$  and  $\overline{U/D}$  can be changed with the clock in either state, provided only that the recommended setup and hold times are observed.

Two types of outputs are provided as overflow/underflow indicators. The Terminal Count (TC) output is normally LOW and goes HIGH when a circuit reaches zero in the count-down mode or reaches 9 in the count-up mode. The TC output will then remain HIGH until a state change occurs, whether by counting or presetting or until  $\overline{U/D}$  is changed. The TC output should not be used as a clock signal because it is subject to decoding spikes. The TC signal is also used internally to enable the Ripple Clock ( $\overline{RC}$ ) output. The  $\overline{RC}$  output is normally HIGH. When  $\overline{CE}$  is LOW and TC is HIGH, the  $\overline{RC}$  output will go LOW when the clock next goes LOW and will stay LOW until the clock goes HIGH again. This feature simplifies the design of multistage counters. For a discussion and illustrations of the various methods of implementing multistage counters, please see the 'F191 data sheet.

## Mode Select Table

INPUTS				MODE
$\overline{PL}$	$\overline{CE}$	$\overline{U/D}$	CP	
H	L	L	$\uparrow$	Count Up
H	L	H	$\uparrow$	Count Down
L	X	X	X	Preset (Asyn.)
H	H	X	X	No Change (Hold)

## $\overline{RC}$ Truth Table

INPUTS			OUTPUT
$\overline{CE}$	TC*	CP	$\overline{RC}$
L	H	$\uparrow$	$\downarrow$
H	X	X	H
X	L	X	H

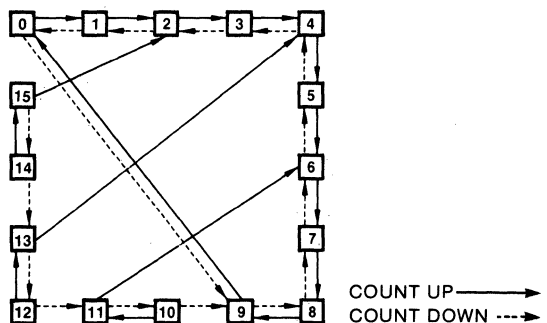
\*TC is generated internally

H = HIGH Voltage Level

L = LOW Voltage Level

X = Immaterial

## State Diagram



## DC Characteristics Over Operating Temperature Range (unless otherwise specified)

Symbol	Parameter	54F/74F			Units	Conditions
		Min	Typ	Max		
$I_{CC}$	Power Supply Current		38	55	mA	$V_{CC} = \text{Max}$

**AC Characteristics:** See Section 3 for waveforms and load configurations

Symbol	Parameter	54F/74F			54F		74F		Units	Fig. No.
		T <sub>A</sub> = +25°C, V <sub>CC</sub> = +5.0 V C <sub>L</sub> = 50 pF			T <sub>A</sub> , V <sub>CC</sub> = Mil C <sub>L</sub> = 50 pF		T <sub>A</sub> , V <sub>CC</sub> = Com C <sub>L</sub> = 50 pF			
		Min	Typ	Max	Min	Max	Min	Max		
f <sub>max</sub>	Maximum Count Frequency	80	110		80		80	MHz	3-1, 3-7	
t <sub>PLH</sub> t <sub>PHL</sub>	Propagation Delay CP to Q <sub>n</sub>	3.0	5.5	9.0	3.0	12.5	3.0	10	ns	3-1 3-7
t <sub>PLH</sub> t <sub>PHL</sub>	Propagation Delay CP to TC	3.0	6.5	10	3.0	14	3.0	11		
t <sub>PLH</sub> t <sub>PHL</sub>	Propagation Delay CP to RC	8.0	12.5	16	8.0	22.5	8.0	17	ns	3-1 3-4
t <sub>PLH</sub> t <sub>PHL</sub>	Propagation Delay CP to RC	5.0	9.5	13	5.0	18	5.0	14		
t <sub>PLH</sub> t <sub>PHL</sub>	Propagation Delay CE to RC	4.0	7.0	9.5	4.0	13.5	4.0	10.5	ns	3-1 3-4
t <sub>PLH</sub> t <sub>PHL</sub>	Propagation Delay CE to RC	3.0	4.6	7.0	3.0	10	3.0	8.0		
t <sub>PLH</sub> t <sub>PHL</sub>	Propagation Delay U/D to RC	3.0	4.6	7.0	3.0	10	3.0	8.0	ns	3-1 3-2
t <sub>PLH</sub> t <sub>PHL</sub>	Propagation Delay U/D to RC	3.0	4.5	7.0	3.0	10	3.0	8.0		
t <sub>PLH</sub> t <sub>PHL</sub>	Propagation Delay U/D to TC	7.0	11	18	7.0	25.5	7.0	19	ns	3-1 3-2
t <sub>PLH</sub> t <sub>PHL</sub>	Propagation Delay U/D to TC	5.0	9.0	12	5.0	17	5.0	13		
t <sub>PLH</sub> t <sub>PHL</sub>	Propagation Delay P <sub>n</sub> to Q <sub>n</sub>	3.0	4.6	7.0	3.0	10	3.0	8.0	ns	3-1 3-4
t <sub>PLH</sub> t <sub>PHL</sub>	Propagation Delay P <sub>n</sub> to Q <sub>n</sub>	8.0	13.4	17	8.0	24	8.0	18		
t <sub>PLH</sub> t <sub>PHL</sub>	Propagation Delay PL to Q <sub>n</sub>	3.0	6.7	11	3.0	15.5	3.0	12	ns	3-1 3-11
t <sub>PLH</sub> t <sub>PHL</sub>	Propagation Delay PL to Q <sub>n</sub>	4.0	7.2	15	4.0	21	4.0	16		

**AC Operating Requirements:** See Section 3 for waveforms

Symbol	Parameter	54F/74F			54F		74F		Units	Fig. No.
		T <sub>A</sub> = +25°C, V <sub>CC</sub> = +5.0 V			T <sub>A</sub> , V <sub>CC</sub> = Mil		T <sub>A</sub> , V <sub>CC</sub> = Com			
		Min	Typ	Max	Min	Max	Min	Max		
t <sub>s</sub> (H) t <sub>s</sub> (L)	Setup Time, HIGH or LOW P <sub>n</sub> to PL	5.0			5.0		5.0		ns	3-14
t <sub>h</sub> (H) t <sub>h</sub> (L)	Hold Time, HIGH or LOW P <sub>n</sub> to PL	8.0			8.0		8.0			
t <sub>s</sub> (L)	Setup Time LOW CE to CP	3.0			3.0		3.0		ns	3-5
t <sub>h</sub> (L)	Hold Time LOW CE to CP	3.0			3.0		3.0			
t <sub>w</sub> (L)	PL Pulse Width LOW	10			10		10		ns	3-11
t <sub>w</sub> (L)	CP Pulse Width LOW	0			0		0		ns	3-7
t <sub>rec</sub>	Recovery Time PL to CP	6.0			6.0		6.0		ns	3-11

■ Test limits in screened columns are preliminary.

# 54F/74F191

Up/Down Binary Counter  
(With Preset and Ripple Clock)

## Description

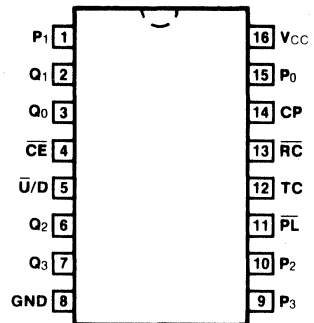
The 'F191 is a reversible modulo-16 binary counter featuring synchronous counting and asynchronous presetting. The preset feature allows the 'F191 to be used in programmable dividers. The Count Enable input, the Terminal Count output and the Ripple Clock output make possible a variety of methods of implementing multistage counters. In the counting modes, state changes are initiated by the rising edge of the clock.

- High-Speed — 110 MHz Typical Count Frequency
- Synchronous Counting
- Asynchronous Parallel Load
- Cascadable

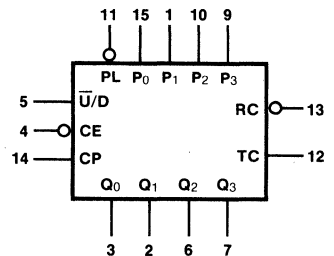
Ordering Code: See Section 6

Pkgs	Commercial Grade	Military Grade	Pkg Type
	$V_{CC} = +5.0 \text{ V} \pm 5\%$ , $T_A = 0^\circ \text{ C to } +70^\circ \text{ C}$	$V_{CC} = +5.0 \text{ V} \pm 10\%$ , $T_A = -55^\circ \text{ C to } +125^\circ \text{ C}$	
Plastic DIP (P)	74F191PC		9B
Ceramic DIP (D)	74F191DC	54F191DM	7B
Flatpak (F)		54F191FM	4L

## Connection Diagram



## Logic Symbol



$V_{CC}$  = Pin 16  
GND = Pin 8

Input Loading/Fan-Out: See Section 3 for U.L. definitions

Pin Names	Description	54F/74F (U.L.) HIGH/LOW
$\overline{CE}$	Count Enable Input (Active LOW)	0.5/1.125
CP	Clock Pulse Input (Active Rising Edge)	0.5/0.375
$P_0 - P_3$	Parallel Data Inputs	0.5/0.375
$\overline{PL}$	Asynchronous Parallel Load Input (Active LOW)	0.5/0.375
$\overline{U/D}$	Up/Down Count Control Input	0.5/0.375
$Q_0 - Q_3$	Flip-flop Outputs	25/12.5
$\overline{RC}$	Ripple Clock Output (Active LOW)	25/12.5
TC	Terminal Count Output (Active HIGH)	25/12.5

### Functional Description

The 'F191 is a synchronous up/down 4-bit binary counter. It contains four edge-triggered flip-flops, with internal gating and steering logic to provide individual preset, count-up and count-down operations.

Each circuit has an asynchronous parallel load capability permitting the counter to be preset to any desired number. When the Parallel Load ( $\overline{PL}$ ) input is LOW, information present on the Parallel Data inputs ( $P_0 - P_3$ ) is loaded into the counter and appears on the Q outputs. This operation overrides the counting functions, as indicated in the Mode Select Table.

A HIGH signal on the  $\overline{CE}$  input inhibits counting. When  $\overline{CE}$  is LOW, internal state changes are initiated synchronously by the LOW-to-HIGH transition of the clock input. The direction of counting is determined by the  $\overline{U/D}$  input signal, as indicated in the Mode Select Table.  $\overline{CE}$  and  $\overline{U/D}$  can be changed with the clock in either state, provided only that the recommended setup and hold times are observed.

Mode Select Table

INPUTS				MODE
$\overline{PL}$	$\overline{CE}$	$\overline{U/D}$	CP	
H	L	L	$\downarrow$	Count Up
H	L	H	$\downarrow$	Count Down
L	X	X	X	Preset (Asyn.)
H	H	X	X	No Change (Hold)

H = HIGH Voltage Level

L = LOW Voltage Level

X = Immaterial

Two types of outputs are provided as overflow/underflow indicators. The Terminal Count (TC) output is normally LOW and goes HIGH when a circuit reaches zero in the count-down mode or reaches 15 in the count-up mode. The TC output will then remain HIGH until a state change occurs, whether by counting or presetting or until  $\overline{U/D}$  is changed. The TC output should not be used as a clock signal because it is subject to decoding spikes.

The TC signal is also used internally to enable the Ripple Clock ( $\overline{RC}$ ) output. The  $\overline{RC}$  output is normally

HIGH. When  $\overline{CE}$  is LOW and TC is HIGH, the  $\overline{RC}$  output will go LOW when the clock next goes LOW and will stay LOW until the clock goes HIGH again. This feature simplifies the design of multistage counters, as indicated in *Figures a* and *b*. In *Figure a*, each  $\overline{RC}$  output is used as the clock input for the next higher stage. This configuration is particularly advantageous when the clock source has a limited drive capability, since it drives only the first stage. To prevent counting in all stages it is only necessary to inhibit the first stage, since a HIGH signal on  $\overline{CE}$  inhibits the  $\overline{RC}$  output pulse, as indicated in the  $\overline{RC}$  Truth Table. A disadvantage of this configuration, in some applications, is the timing skew between state changes in the first and last stages. This represents the cumulative delay of the clock as it ripples through the preceding stages.

$\overline{RC}$  Truth Table

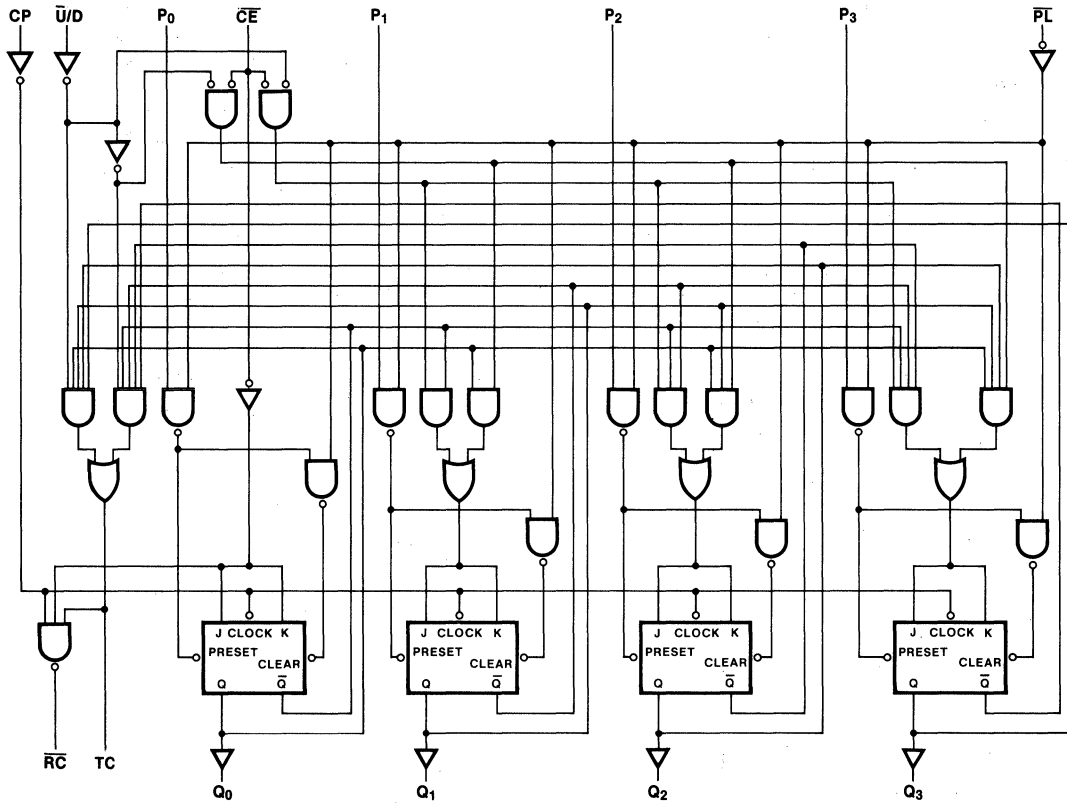
INPUTS			OUTPUT
$\overline{CE}$	TC*	CP	$\overline{RC}$
L	H	$\downarrow$	$\downarrow$
H	X	X	H
X	L	X	H

\*TC is generated internally

A method of causing state changes to occur simultaneously in all stages is shown in *Figure b*. All clock inputs are driven in parallel and the  $\overline{RC}$  outputs propagate the carry/borrow signals in ripple fashion. In this configuration the LOW state duration of the clock must be long enough to allow the negative-going edge of the carry/borrow signal to ripple through to the last stage before the clock goes HIGH. There is no such restriction on the HIGH state duration of the clock, since the  $\overline{RC}$  output of any device goes HIGH shortly after its CP input goes HIGH.

The configuration shown in *Figure c* avoids ripple delays and their associated restrictions. The  $\overline{CE}$  input for a given stage is formed by combining the TC signals from all the preceding stages. Note that in order to inhibit counting an enable signal must be included in each carry gate. The simple inhibit scheme of *Figures a* and *b* doesn't apply, because the TC output of a given stage is not affected by its own  $\overline{CE}$ .

Logic Diagram



Please note that this diagram is provided only for the understanding of logic operations and should not be used to estimate propagation delays.

Fig. a N-Stage Counter Using Ripple Clock

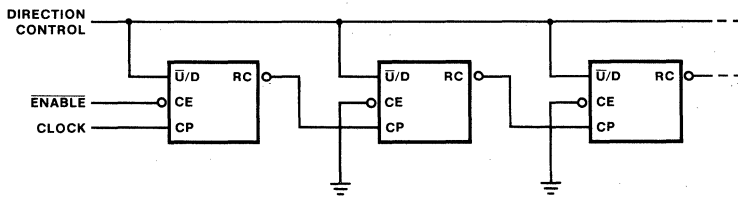


Fig. b Synchronous N-Stage Counter Using Ripple Carry/Borrow

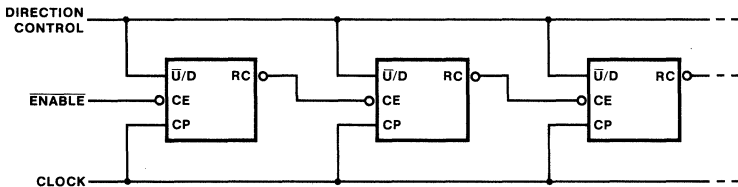
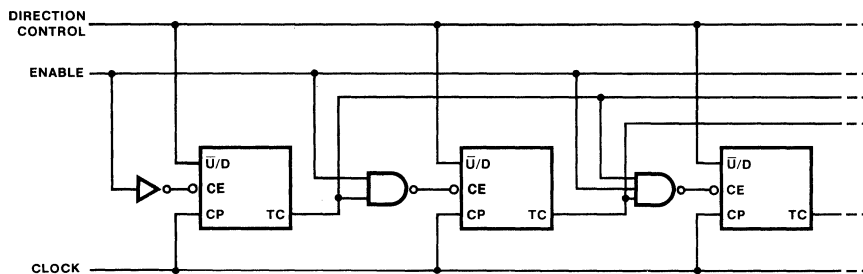


Fig. c Synchronous N-Stage Counter with Parallel Gated Carry/Borrow



## DC Characteristics Over Operating Temperature Range (unless otherwise specified)

Symbol	Parameter	54F/74F			Units	Conditions
		Min	Typ	Max		
$I_{CC}$	Power Supply Current		38	55	mA	$V_{CC} = \text{Max}$

## AC Characteristics: See Section 3 for waveforms and load configurations

Symbol	Parameter	54F/74F			54F		74F		Units	Fig. No.
		$T_A = +25^\circ\text{C}$ , $V_{CC} = +5.0\text{V}$ $C_L = 50\text{pF}$			$T_A, V_{CC} = \text{Mil}$ $C_L = 50\text{pF}$		$T_A, V_{CC} = \text{Com}$ $C_L = 50\text{pF}$			
		Min	Typ	Max	Min	Max	Min	Max		
$f_{\text{max}}$	Maximum Count Frequency	80	110		80		80	MHz	3-1, 3-7	
$t_{\text{PLH}}$ $t_{\text{PHL}}$	Propagation Delay CP to $Q_n$	3.0 3.0	5.5 6.5	9.0 10	3.0 3.0	12.5 14	3.0 3.0	10 11	ns	3-1 3-7
$t_{\text{PLH}}$ $t_{\text{PHL}}$	Propagation Delay CP to TC	8.0 5.0	12.5 9.5	16 13	8.0 5.0	22.5 18	8.0 5.0	17 14	ns	3-1 3-4
$t_{\text{PLH}}$ $t_{\text{PHL}}$	Propagation Delay CP to RC	4.0 3.0	7.0 5.0	9.5 8.0	4.0 3.0	13.5 11	4.0 3.0	10.5 9.0	ns	3-1 3-4
$t_{\text{PLH}}$ $t_{\text{PHL}}$	Propagation Delay $\overline{U/D}$ to RC	7.0 5.0	11 9.0	18 12	7.0 5.0	25.5 17	7.0 5.0	19 13	ns	3-1 3-2
$t_{\text{PLH}}$ $t_{\text{PHL}}$	Propagation Delay $\overline{U/D}$ to TC	3.0 3.0	6.0 6.5	11 11	3.0 3.0	15.5 15.5	3.0 3.0	12 12	ns	3-1 3-4
$t_{\text{PLH}}$ $t_{\text{PHL}}$	Propagation Delay $P_n$ to $Q_n$	3.0 8.0	4.6 13.4	7.0 17	3.0 8.0	10 24	3.0 8.0	8.0 18	ns	3-1 3-4
$t_{\text{PLH}}$ $t_{\text{PHL}}$	Propagation Delay $\overline{P_L}$ to $Q_n$	3.0 4.0	6.7 7.2	11 15	3.0 4.0	15.5 21	3.0 4.0	12 16	ns	3-1 3-11

■ Test limits in screened columns are preliminary.

**AC Operating Requirements:** See Section 3 for waveforms

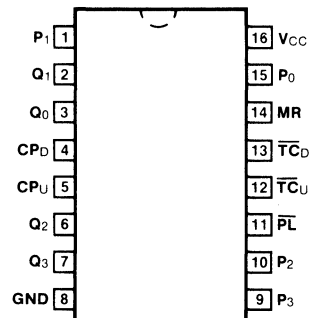
Symbol	Parameter	54F/74F			54F		74F		Units	Fig. No.
		T <sub>A</sub> = +25°C, V <sub>CC</sub> = +5.0 V			T <sub>A</sub> , V <sub>CC</sub> = Mil		T <sub>A</sub> , V <sub>CC</sub> = Com			
		Min	Typ	Max	Min	Max	Min	Max		
t <sub>s</sub> (H) t <sub>s</sub> (L)	Setup Time, HIGH or LOW P <sub>n</sub> to $\overline{PL}$	5.0			5.0		5.0	ns	3-14	
		8.0			8.0		8.0			
t <sub>h</sub> (H) t <sub>h</sub> (L)	Hold Time, HIGH or LOW P <sub>n</sub> to $\overline{PL}$	3.0			3.0		3.0	ns	3-5	
		3.0			3.0		3.0			
t <sub>s</sub> (L)	Setup Time LOW $\overline{CE}$ to CP	10			10		10	ns	3-5	
t <sub>h</sub> (L)	Hold Time LOW $\overline{CE}$ to CP	0			0		0			
t <sub>w</sub> (L)	$\overline{PL}$ Pulse Width, LOW	6.0			6.0		6.0	ns	3-11	
t <sub>w</sub> (L)	CP Pulse Width, LOW	6.0			6.0		6.0	ns	3-7	
t <sub>rec</sub>	Recovery Time $\overline{PL}$ to CP	7.0			7.0		7.0	ns	3-11	

■ Test limits in screened columns are preliminary.

# 54F/74F192

Up/Down Decade Counter  
(With Separate Up/Down Clocks)

## Connection Diagram

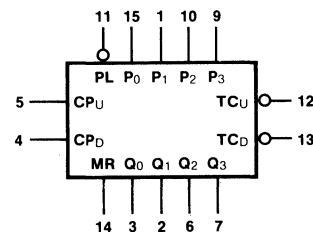


### Description

The 'F192 is an up/down BCD decade (8421) counter. Separate Count Up and Count Down Clocks are used, and in either counting mode the circuits operate synchronously. The outputs change state synchronously with the LOW-to-HIGH transitions on the clock inputs.

Separate Terminal Count Up and Terminal Count Down outputs are provided that are used as the clocks for a subsequent stage without extra logic, thus simplifying multistage counter designs. Individual preset inputs allow the circuit to be used as a programmable counter. Both the Parallel Load (PL) and the Master Reset (MR) inputs asynchronously override the clocks.

## Logic Symbol



V<sub>CC</sub> = Pin 16  
GND = Pin 8

Ordering Code: See Section 6

Pkgs	Commercial Grade	Military Grade	Pkg Type
	V <sub>CC</sub> = +5.0 V ±5%, T <sub>A</sub> = 0°C to +70°C	V <sub>CC</sub> = +5.0 V ±10%, T <sub>A</sub> = -55°C to +125°C	
Plastic DIP (P)	74F192PC		9B
Ceramic DIP (D)	74F192DC	54F192DM	6B
Flatpak (F)		54F192FM	4L

Input Loading/Fan-Out: See Section 3 for U.L. definitions

Pin Names	Description	54F/74F (U.L.) HIGH/LOW
CP <sub>U</sub>	Count Up Clock Input (Active Rising Edge)	0.5/0.75
CP <sub>D</sub>	Count Down Clock Input (Active Rising Edge)	0.5/0.75
MR	Asynchronous Master Reset Input (Active HIGH)	0.5/0.375
PL	Asynchronous Parallel Load Input (Active LOW)	0.5/0.375
P <sub>0</sub> - P <sub>3</sub>	Parallel Data Inputs	0.5/0.375
Q <sub>0</sub> - Q <sub>3</sub>	Flip-flop Outputs	25/12.5
TC <sub>D</sub>	Terminal Count Down (Borrow) Output (Active LOW)	25/12.5
TC <sub>U</sub>	Terminal Count Up (Carry) Output (Active LOW)	25/12.5



## Functional Description

The 'F192 is an asynchronously presettable decade counter. It contains four edge-triggered flip-flops, with internal gating and steering logic to provide master reset, individual preset, count up and count down operations.

A LOW-to-HIGH transition on the CP input to each flip-flop causes the output to change state. Synchronous switching, as opposed to ripple counting, is achieved by driving the steering gates of all stages from a common Count Up line and a common Count Down line, thereby causing all state changes to be initiated simultaneously. A LOW-to-HIGH transition on the Count Up input will advance the count by one; a similar transition on the Count Down input will decrease the count by one. While counting with one clock input, the other should be held HIGH, as indicated in the Function Table. Otherwise, the circuit will either count by twos or not at all, depending on the state of the first flip-flop, which cannot toggle as long as either clock input is LOW.

The Terminal Count Up ( $\overline{TCU}$ ) and Terminal Count Down ( $\overline{TCD}$ ) outputs are normally HIGH. When the circuit has reached the maximum count state 9, the next HIGH-to-LOW transition of the Count Up Clock

will cause  $\overline{TCU}$  to go LOW.  $\overline{TCU}$  will stay LOW until CPU goes HIGH again, thus effectively repeating the Count Up Clock, but delayed by two gate delays. Similarly, the  $\overline{TCD}$  output will go LOW when the circuit is in the zero state and the Count Down Clock goes LOW. Since the  $\overline{TC}$  outputs repeat the clock waveforms, they can be used as the clock input signals to the next higher order circuit in a multistage counter.

$$\overline{TCU} = Q_0 \cdot Q_3 \cdot \overline{CPU}$$

$$\overline{TCD} = \overline{Q_0} \cdot \overline{Q_1} \cdot \overline{Q_2} \cdot \overline{Q_3} \cdot \overline{CPD}$$

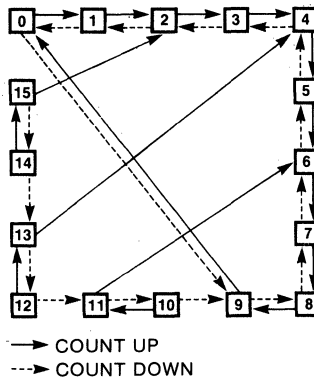
The 'F192 has an asynchronous parallel load capability permitting the counter to be preset. When the Parallel Load ( $\overline{PL}$ ) and the Master Reset (MR) inputs are LOW, information present on the Parallel Data input ( $P_0 - P_3$ ) is loaded into the counter and appears on the outputs regardless of the conditions of the clock inputs. A HIGH signal on the Master Reset input will disable the preset gates, override both clock inputs, and latch each Q output in the LOW state. If one of the clock inputs is LOW during and after a reset or load operation, the next LOW-to-HIGH transition of that clock will be interpreted as a legitimate signal and will be counted.

**Function Table**

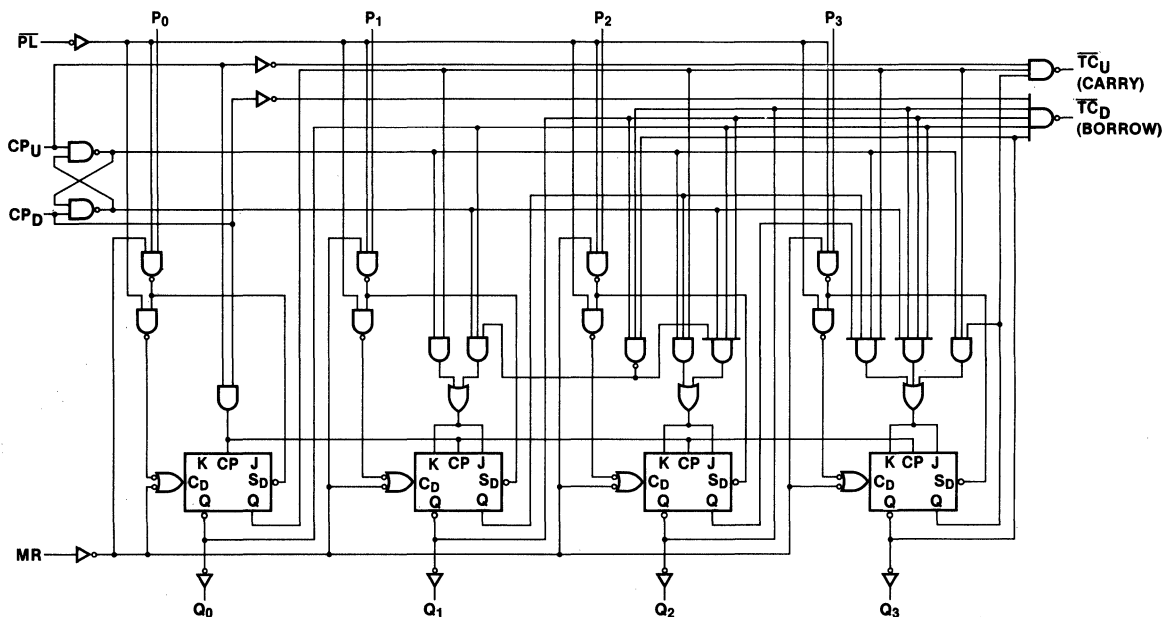
MR	$\overline{PL}$	CP <sub>U</sub>	CP <sub>D</sub>	MODE
H	X	X	X	Reset (Asyn.)
L	L	X	X	Preset (Asyn.)
L	H	H	H	No Change
L	H	⌋	H	Count Up
L	H	H	⌋	Count Down

H = HIGH Voltage Level  
 L = LOW Voltage Level  
 X = Immaterial

**State Diagram**



Logic Diagram



Please note that this diagram is provided only for the understanding of logic operations and should not be used to estimate propagation delays.

DC Characteristics over Operating Temperature Range (unless otherwise specified)

Symbol	Parameter	54F/74F			Units	Conditions
		Min	Typ	Max		
I <sub>CC</sub>	Power Supply Current		30	45	mA	V <sub>CC</sub> = Max

AC Characteristics: See Section 3 for waveforms and load configurations

Symbol	Parameter	54F/74F			54F	74F	Units	Fig. No.
		T <sub>A</sub> = +25° C, V <sub>CC</sub> = +5.0 V, C <sub>L</sub> = 50 pF			T <sub>A</sub> , V <sub>CC</sub> = Mil, C <sub>L</sub> = 50 pF	T <sub>A</sub> , V <sub>CC</sub> = Com, C <sub>L</sub> = 50 pF		
		Min	Typ	Max	Min	Max		
f <sub>max</sub>	Maximum Count Frequency	80					MHz	3-1, 3-7
t <sub>PLH</sub>	Propagation Delay	3.0	6.5	9.0			ns	3-1 3-4
t <sub>PHL</sub>	CP <sub>U</sub> or CP <sub>D</sub> to $\overline{TC}_U$	3.0	6.5	9.0				
t <sub>PLH</sub>	Propagation Delay	5.0	9.0	13			ns	3-1 3-7
t <sub>PHL</sub>	CP <sub>U</sub> or CP <sub>D</sub> to Q <sub>n</sub>	3.5	6.0	8.5				

■ Test limits in screened columns are preliminary.

**AC Characteristics** (Cont'd): See Section 3 for waveforms and load configurations

Symbol	Parameter	54F/74F			54F		74F		Units	Fig. No.
		T <sub>A</sub> = +25°C, V <sub>CC</sub> = +5.0 V C <sub>L</sub> = 50 pF			T <sub>A</sub> , V <sub>CC</sub> = Mil C <sub>L</sub> = 50 pF		T <sub>A</sub> , V <sub>CC</sub> = Com C <sub>L</sub> = 50 pF			
		Min	Typ	Max	Min	Max	Min	Max		
t <sub>PLH</sub> t <sub>PHL</sub>	Propagation Delay P <sub>n</sub> to Q <sub>n</sub>	3.0 5.0	5.0 9.0	7.0 12.5				ns	3-1 3-4	
t <sub>PLH</sub> t <sub>PHL</sub>	Propagation Delay $\overline{PL}$ to Q <sub>n</sub>	4.0 4.5	7.0 7.5	10 10.5				ns	3-1 3-10	
t <sub>PHL</sub>	Propagation Delay MR to Q <sub>n</sub>	5.5	9.5	13.5						
t <sub>PLH</sub>	Propagation Delay MR to $\overline{TCU}$	7.5	13	18				ns	3-1 3-11	
t <sub>PHL</sub>	Propagation Delay MR to $\overline{TCD}$	7.0	12	17						
t <sub>PLH</sub> t <sub>PHL</sub>	Propagation Delay $\overline{PL}$ to $\overline{TCU}$ or $\overline{TCD}$	7.5 6.0	13 10	18 14				ns	3-1 3-10	
t <sub>PLH</sub> t <sub>PHL</sub>	Propagation Delay P <sub>n</sub> to $\overline{TCU}$ or $\overline{TCD}$	9.0 6.5	15 11	21 15.5				ns	3-1 3-10	

**AC Operating Requirements:** See Section 3 for waveforms

Symbol	Parameter	54F/74F			54F		74F		Units	Fig. No.
		T <sub>A</sub> = +25°C, V <sub>CC</sub> = +5.0 V			T <sub>A</sub> , V <sub>CC</sub> = Mil		T <sub>A</sub> , V <sub>CC</sub> = Com			
		Min	Typ	Max	Min	Max	Min	Max		
t <sub>s</sub> (H) t <sub>s</sub> (L)	Setup Time, HIGH or LOW P <sub>n</sub> to $\overline{PL}$	5.0 8.0						ns	3-14	
t <sub>h</sub> (H) t <sub>h</sub> (L)	Hold Time, HIGH or LOW P <sub>n</sub> to $\overline{PL}$	3.0 3.0								
t <sub>w</sub> (L)	$\overline{PL}$ Pulse Width LOW	12						ns	3-11	
t <sub>w</sub> (L)	CP <sub>U</sub> or CP <sub>D</sub> Pulse Width LOW	8.0						ns	3-7	
t <sub>w</sub> (H)	MR Pulse Width HIGH	8.0						ns	3-11	
t <sub>rec</sub>	Recovery Time $\overline{PL}$ to CP <sub>U</sub> or CP <sub>D</sub>	10						ns	3-11	
t <sub>rec</sub>	Recovery Time MR to CP <sub>U</sub> or CP <sub>D</sub>	6.0						ns	3-11	

■ Test limits in screened columns are preliminary.

# 54F/74F193

Up/Down Binary Counter  
(With Separate Up/Down Clocks)

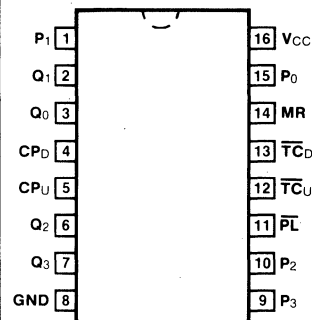
### Description

The 'F193 is an up/down modulo-16 binary counter. Separate Count Up and Count Down Clocks are used, and in either counting mode the circuits operate synchronously. The outputs change state synchronously with the LOW-to-HIGH transitions on the clock inputs. Separate Terminal Count Up and Terminal Count Down outputs are provided that are used as the clocks for subsequent stages without extra logic, thus simplifying multistage counter designs. Individual preset inputs allow the circuit to be used as a programmable counter. Both the Parallel Load (PL) and the Master Reset (MR) inputs asynchronously override the clocks.

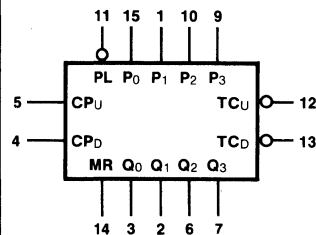
Ordering Code: See Section 6

Pkgs	Commercial Grade	Military Grade	Pkg Type
	V <sub>CC</sub> = +5.0 V ±5%, T <sub>A</sub> = 0° C to +70° C	V <sub>CC</sub> = +5.0 V ±10%, T <sub>A</sub> = -55° C to +125° C	
Plastic DIP (P)	74F193PC		9B
Ceramic DIP (D)	74F193DC	54F193DM	6B
Flatpak (F)		54F193FM	4L

### Connection Diagram



### Logic Symbol



V<sub>CC</sub> = Pin 16  
GND = Pin 8

Input Loading/Fan-Out: See Section 3 for U.L. definitions

Pin Names	Description	54F/74F (U.L.) HIGH/LOW
CP <sub>U</sub>	Count Up Clock Input (Active Rising Edge)	0.5/0.75
CP <sub>D</sub>	Count Down Clock Input (Active Rising Edge)	0.5/0.75
MR	Asynchronous Master Reset Input (Active HIGH)	0.5/0.375
PL	Asynchronous Parallel Load Input (Active LOW)	0.5/0.375
P <sub>0</sub> - P <sub>3</sub>	Parallel Data Inputs	0.5/0.375
Q <sub>0</sub> - Q <sub>3</sub>	Flip-flop Outputs	25/12.5
T <sub>C</sub> <sub>D</sub>	Terminal Count Down (Borrow) Output (Active LOW)	25/12.5
T <sub>C</sub> <sub>U</sub>	Terminal Count Up (Carry) Output (Active LOW)	25/12.5

## Function Description

The 'F193 is a 4-bit binary synchronous up/down (reversible) counter. It contains four edge-triggered flip-flops, with internal gating and steering logic to provide master reset, individual preset, count up and count down operations.

A LOW-to-HIGH transition on the CP input to each flip-flop causes the output to change state. Synchronous switching, as opposed to ripple counting, is achieved by driving the steering gates of all stages from a common Count Up line and a common Count Down line, thereby causing all state changes to be initiated simultaneously. A LOW-to-HIGH transition on the Count Up input will advance the count by one; a similar transition on the Count Down input will decrease the count by one. While counting with one clock input, the other should be held HIGH, as indicated in the Function Table. Otherwise, the circuit will either count by twos or not at all, depending on the state of the first flip-flop, which cannot toggle as long as either clock input is LOW.

The Terminal Count Up ( $\overline{TC}_U$ ) and Terminal Count Down ( $\overline{TC}_D$ ) outputs are normally HIGH. When the circuit has reached the maximum count state 15, the next HIGH-to-LOW transition of the Count Up Clock



will cause  $\overline{TC}_U$  to go LOW.  $\overline{TC}_U$  will stay LOW until CPU goes HIGH again, thus effectively repeating the Count Up Clock, but delayed by two gate delays. Similarly, the  $\overline{TC}_D$  output will go LOW when the circuit is in the zero state and the Count Down Clock goes LOW. Since the TC outputs repeat the clock waveforms, they can be used as the clock input signals to the next higher order circuit in a multistage counter.

$$\overline{TC}_U = Q_0 \cdot Q_1 \cdot Q_2 \cdot Q_3 \cdot \overline{CPU}$$

$$\overline{TC}_D = \overline{Q_0} \cdot \overline{Q_1} \cdot \overline{Q_2} \cdot \overline{Q_3} \cdot \overline{CPD}$$

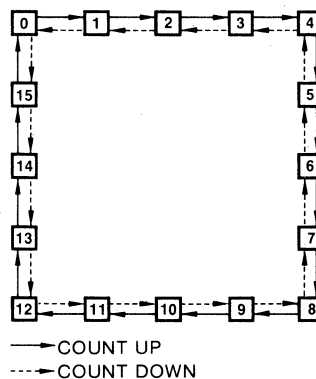
The 'F193 has an asynchronous parallel load capability permitting the counter to be preset. When the Parallel Load ( $\overline{PL}$ ) and the Master Reset (MR) inputs are LOW, information present on the Parallel Data input (P<sub>0</sub> - P<sub>3</sub>) is loaded into the counter and appears on the outputs regardless of the conditions of the clock inputs. A HIGH signal on the Master Reset input will disable the preset gates, override both clock inputs, and latch each Q output in the LOW state. If one of the clock inputs is LOW during and after a reset or load operation, the next LOW-to-HIGH transition of that clock will be interpreted as a legitimate signal and will be counted.

**Function Table**

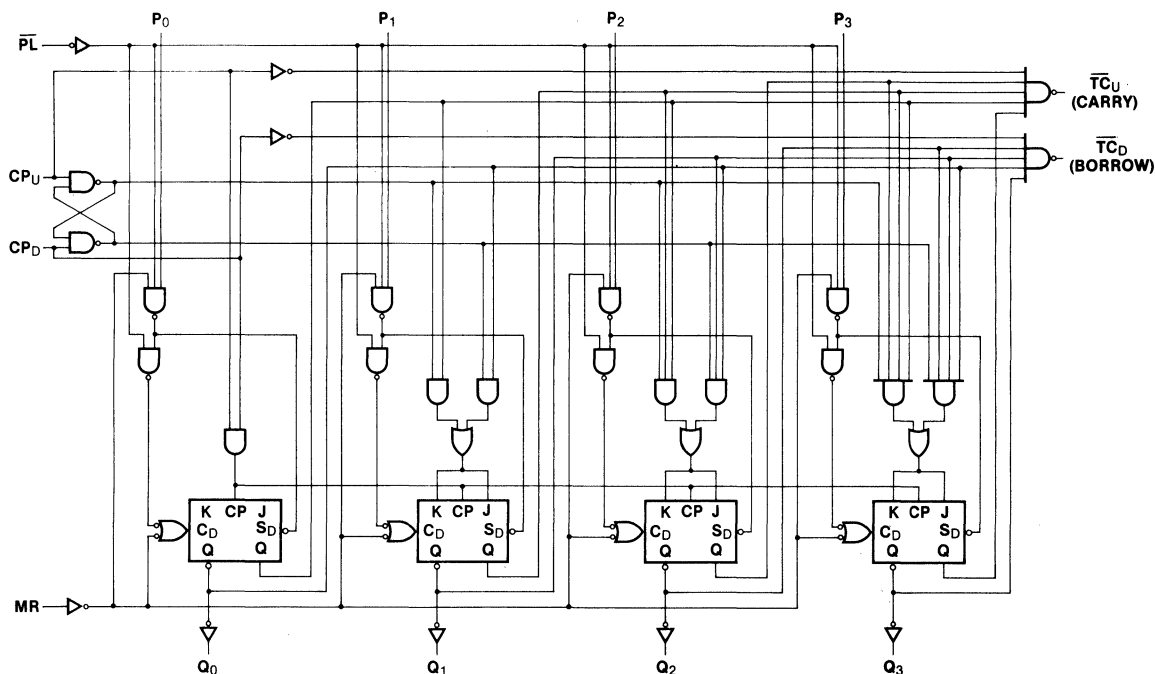
MR	$\overline{PL}$	CP <sub>U</sub>	CP <sub>D</sub>	MODE
H	X	X	X	Reset (Asyn.)
L	L	X	X	Preset (Asyn.)
L	H	H	H	No Change
L	H		H	Count Up
L	H	H		Count Down

H = HIGH Voltage Level  
 L = LOW Voltage Level  
 X = Immaterial

**State Diagram**



Logic Diagram



4

Please note that this diagram is provided only for the understanding of logic operations and should not be used to estimate propagation delays.

DC Characteristics Over Operating Temperature Range (unless otherwise specified)

Symbol	Parameter	54F/74F			Units	Conditions
		Min	Typ	Max		
I <sub>CC</sub>	Power Supply Current		30	45	mA	V <sub>CC</sub> = Max

AC Characteristics: See Section 3 for waveforms and load configurations

Symbol	Parameter	54F/74F			54F	74F	Units	Fig. No.	
		T <sub>A</sub> = +25° C, V <sub>CC</sub> = +5.0 V, C <sub>L</sub> = 50 pF			T <sub>A</sub> , V <sub>CC</sub> = Mil, C <sub>L</sub> = 50 pF	T <sub>A</sub> , V <sub>CC</sub> = Com, C <sub>L</sub> = 50 pF			
		Min	Typ	Max	Min	Max			Min
f <sub>max</sub>	Maximum Count Frequency	80				80	MHz	3-1, 3-7	
t <sub>PLH</sub>	Propagation Delay	5.0	9.0	11.5		5.0	12.5	ns	3-1 3-4
t <sub>PHL</sub>	CP <sub>U</sub> or CP <sub>D</sub> to TC <sub>U</sub>	3.5	6.0	8.0		3.5	9.0		
t <sub>PLH</sub>	Propagation Delay	3.0	6.5	9.5		3.0	10.5	ns	3-1 3-7
t <sub>PHL</sub>	CP <sub>U</sub> or CP <sub>D</sub> to Q <sub>n</sub>	3.0	6.5	9.5		3.0	10.5		

**AC Characteristics** (Cont'd): See Section 3 for waveforms and load configurations

Symbol	Parameter	54F/74F			54F		74F		Units	Fig. No.
		T <sub>A</sub> = +25°C, V <sub>CC</sub> = +5.0 V C <sub>L</sub> = 50 pF			T <sub>A</sub> , V <sub>CC</sub> = Mil C <sub>L</sub> = 50 pF		T <sub>A</sub> , V <sub>CC</sub> = Com C <sub>L</sub> = 50 pF			
		Min	Typ	Max	Min	Max	Min	Max		
t <sub>PLH</sub> t <sub>PHL</sub>	Propagation Delay P <sub>n</sub> to Q <sub>n</sub>	3.0 8.5	5.0 9.0	6.5 11.5			3.0 5.0	7.5 12.5	ns	3-1 3-4
t <sub>PLH</sub> t <sub>PHL</sub>	Propagation Delay $\overline{P}$ L to Q <sub>n</sub>	4.0 4.5	7.0 7.5	9.5 10			4.0 4.5	10.5 11	ns	3-1 3-10
t <sub>PHL</sub>	Propagation Delay MR to Q <sub>n</sub>	5.5	9.5	12			5.5	13	ns	3-1 3-11
t <sub>PLH</sub>	Propagation Delay MR to $\overline{T}$ C <sub>U</sub>	8.0	13	17			8.0	18		
t <sub>PHL</sub>	Propagation Delay MR to $\overline{T}$ C <sub>D</sub>	7.0	12	15.5			7.0	16.5		
t <sub>PLH</sub> t <sub>PHL</sub>	Propagation Delay $\overline{P}$ L to $\overline{T}$ C <sub>U</sub> or $\overline{T}$ C <sub>D</sub>	8.0 6.0	13 11	17 15.5			8.0 6.0	18 16.5	ns	3-1 3-10
t <sub>PLH</sub> t <sub>PHL</sub>	Propagation Delay P <sub>n</sub> to T <sub>C</sub> <sub>U</sub> or $\overline{T}$ C <sub>D</sub>	9.0 6.5	15 11	18.5 14			9.0 6.5	19.5 15	ns	3-1 3-10

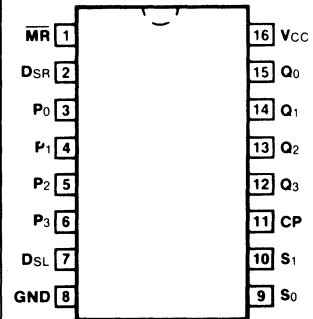
**AC Operating Requirements:** See Section 3 for waveforms

Symbol	Parameter	54F/74F			54F		74F		Units	Fig. No.
		T <sub>A</sub> = +25°C, V <sub>CC</sub> = +5.0 V			T <sub>A</sub> , V <sub>CC</sub> = Mil		T <sub>A</sub> , V <sub>CC</sub> = Com			
		Min	Typ	Max	Min	Max	Min	Max		
t <sub>s</sub> (H) t <sub>s</sub> (L)	Setup Time, HIGH or LOW P <sub>n</sub> to $\overline{P}$ L	5.0 8.0					5.0 8.0		ns	3-14
t <sub>h</sub> (H) t <sub>h</sub> (L)	Hold Time, HIGH or LOW P <sub>n</sub> to $\overline{P}$ L	3.0 3.0					3.0 3.0			
t <sub>w</sub> (L)	$\overline{P}$ L Pulse Width LOW	12					12		ns	3-11
t <sub>w</sub> (L)	CP <sub>U</sub> or CP <sub>D</sub> Pulse Width LOW	8.0					8.0		ns	3-7
t <sub>w</sub> (H)	MR Pulse Width HIGH	8.0					8.0		ns	3-11
t <sub>rec</sub>	Recovery Time $\overline{P}$ L to CP <sub>U</sub> or CP <sub>D</sub>	10					10		ns	3-11
t <sub>rec</sub>	Recovery Time MR to CP <sub>U</sub> or CP <sub>D</sub>	6.0					6.0		ns	3-11

# 54F/74F194

## 4-Bit Bidirectional Universal Shift Register

### Connection Diagram



4

### Description

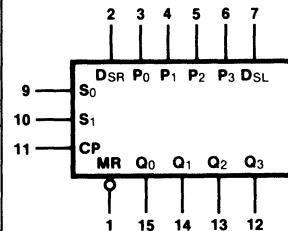
The 'F194 is a high-speed 4-bit bidirectional universal shift register. As a high-speed, multifunctional, sequential building block, it is useful in a wide variety of applications. It may be used in serial-serial, shift left, shift right, serial-parallel, parallel-serial, and parallel-parallel data register transfers. The 'F194 is similar in operation to the 'S195 universal shift register, with added features of shift left without external connections and hold (do nothing) modes of operation.

- Typical Shift Frequency of 150 MHz
- Asynchronous Master Reset
- Hold (Do Nothing) Mode
- Fully Synchronous Serial or Parallel Data Transfers

Ordering Code: See Section 6

Pkgs	Commercial Grade	Military Grade	Pkg Type
	V <sub>CC</sub> = +5.0 V ±5%, T <sub>A</sub> = 0° C to +70° C	V <sub>CC</sub> = +5.0 V ±10%, T <sub>A</sub> = -55° C to +125° C	
Plastic DIP (P)	74F194PC		9B
Ceramic DIP (D)	74F194DC	54F194DM	6B
Flatpak (F)		54F194FM	4L

### Logic Symbol



V<sub>CC</sub> = Pin 16  
GND = Pin 8

Input Loading/Fan-Out: See Section 3 for U.L. definitions

Pin Names	Description	54F/74F (U.L.) HIGH/LOW
S <sub>0</sub> , S <sub>1</sub>	Mode Control Inputs	0.5/0.375
P <sub>0</sub> - P <sub>3</sub>	Parallel Data Inputs	0.5/0.375
DSR	Serial Data Input (Shift Right)	0.5/0.375
DSL	Serial Data Input (Shift Left)	0.5/0.375
CP	Clock Pulse Input (Active Rising Edge)	0.5/0.375
MR	Asynchronous Master Reset Input (Active LOW)	0.5/0.375
Q <sub>0</sub> - Q <sub>3</sub>	Parallel Outputs	25/12.5



## Functional Description

The 'F194 contains four edge-triggered D flip-flops and the necessary interstage logic to synchronously perform shift right, shift left, parallel load and hold operations. Signals applied to the Select ( $S_0, S_1$ ) inputs determine the type of operation, as shown in the Mode Select Table. Signals on the Select,

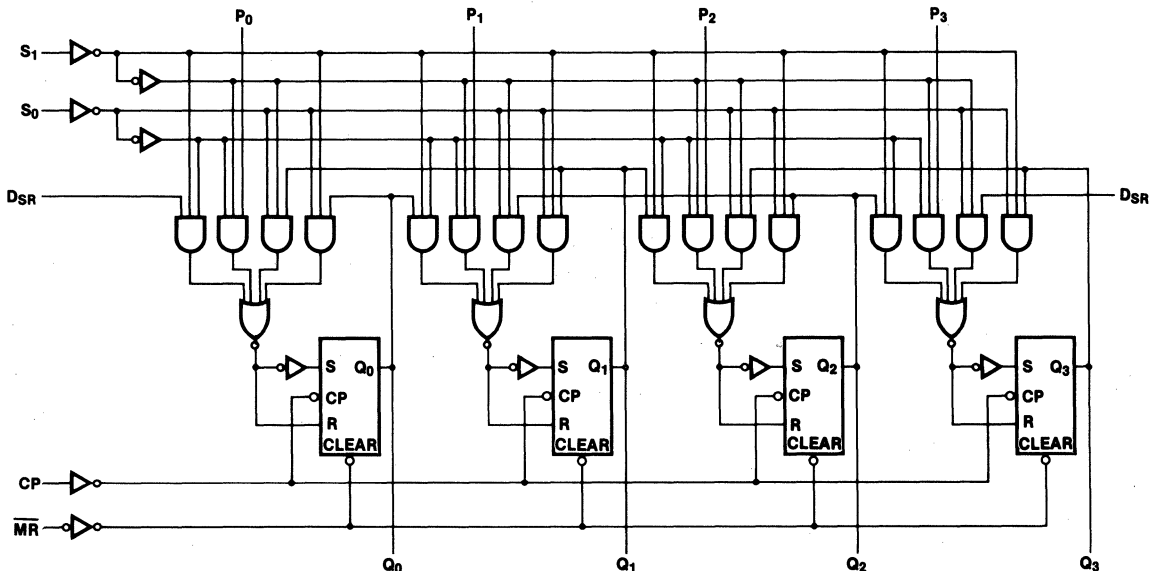
Parallel data ( $P_0 - P_3$ ) and Serial data ( $DSR, DSL$ ) inputs can change when the clock is in either state, provided only that the recommended setup and hold times, with respect to the clock rising edge, are observed. A LOW signal on Master Reset ( $\overline{MR}$ ) overrides all other inputs and forces the outputs LOW.

**Mode Select Table**

OPERATING MODE	INPUTS					OUTPUTS				
	$\overline{MR}$	$S_1$	$S_0$	$DSR$	$DSL$	$P_n$	$Q_0$	$Q_1$	$Q_2$	$Q_3$
Reset	L	X	X	X	X	X	L	L	L	L
Hold	H	l	l	X	X	X	$q_0$	$q_1$	$q_2$	$q_3$
Shift Left	H	h	l	X	l	X	$q_1$	$q_2$	$q_3$	L
	H	h	l	X	h	X	$q_1$	$q_2$	$q_3$	H
Shift Right	H	l	h	l	X	X	L	$q_0$	$q_1$	$q_2$
	H	l	h	h	X	X	H	$q_0$	$q_1$	$q_2$
Parallel Load	H	h	h	X	X	$p_n$	$p_0$	$p_1$	$p_2$	$p_3$


l = LOW voltage level one setup time prior to the LOW-to-HIGH clock transition.  
 h = HIGH voltage level one setup time prior to the LOW-to-HIGH clock transition.  
 $p_n$  ( $q_n$ ) = Lower case letters indicate the state of the referenced input (or output) one setup time prior to the LOW-to-HIGH clock transition.  
 H = HIGH Voltage Level  
 L = LOW Voltage Level  
 X = Immaterial

## Logic Diagram



Please note that this diagram is provided only for the understanding of logic operations and should not be used to estimate propagation delays.

**DC Characteristics over Operating Temperature Range** (unless otherwise specified)

Symbol	Parameter	54F/74F			Units	Conditions
		Min	Typ	Max		
I <sub>CC</sub>	Power Supply Current		33	46	mA	V <sub>CC</sub> = Max S <sub>n</sub> , MR, D <sub>SR</sub> , D <sub>SL</sub> = 4.5 V P <sub>n</sub> = Gnd, CP = 

**AC Characteristics:** See Section 3 for waveforms and load configurations

Symbol	Parameter	54F/74F			54F		74F		Units	Fig. No.
		T <sub>A</sub> = +25°C, V <sub>CC</sub> = +5.0 V C <sub>L</sub> = 50 pF			T <sub>A</sub> , V <sub>CC</sub> = Mil C <sub>L</sub> = 50 pF		T <sub>A</sub> , V <sub>CC</sub> = Com C <sub>L</sub> = 50 pF			
		Min	Typ	Max	Min	Max	Min	Max		
f <sub>max</sub>	Maximum Shift Frequency	105	150		90		90	MHz	3-1, 3-7	
t <sub>PLH</sub>	Propagation Delay	3.5	5.2	7.0	3.0	8.5	3.5	8.0	ns	3-1
t <sub>PHL</sub>	CP to Q <sub>n</sub>	3.5	5.5	7.0	3.0	8.5	3.5	8.0		3-7
t <sub>PHL</sub>	Propagation Delay	4.5	8.6	12	4.5	14.5	4.5	14	ns	3-1 3-11
	MR to Q <sub>n</sub>									

**AC Operating Requirements:** See Section 3 for waveforms

Symbol	Parameter	54F/74F			54F		74F		Units	Fig. No.
		T <sub>A</sub> = +25°C, V <sub>CC</sub> = +5.0 V C <sub>L</sub> = 50 pF			T <sub>A</sub> , V <sub>CC</sub> = Mil C <sub>L</sub> = 50 pF		T <sub>A</sub> , V <sub>CC</sub> = Com C <sub>L</sub> = 50 pF			
		Min	Typ	Max	Min	Max	Min	Max		
t <sub>s</sub> (H)	Setup Time, HIGH or LOW	4.0			4.0		4.0	ns	3-5	
t <sub>s</sub> (L)	P <sub>n</sub> or D <sub>SR</sub> or D <sub>SL</sub> to CP	4.0			4.0		4.0			
t <sub>h</sub> (H)	Hold Time, HIGH or LOW	0			1.0		1.0	ns	3-5	
t <sub>h</sub> (L)	P <sub>n</sub> or D <sub>SR</sub> or D <sub>SL</sub> to CP	0			1.0		1.0			
t <sub>s</sub> (H)	Setup Time, HIGH or LOW	8.0			9.5		9.0	ns	3-5	
t <sub>s</sub> (L)	S <sub>n</sub> to CP	8.0			8.0		8.0			
t <sub>h</sub> (H)	Hold Time, HIGH or LOW	0			0		0	ns	3-5	
t <sub>h</sub> (L)	S <sub>n</sub> to CP	0			0		0			
t <sub>w</sub> (H)	CP Pulse Width HIGH	5.0			5.5		5.5	ns	3-7	
t <sub>w</sub> (L)	MR Pulse Width LOW	5.0			5.0		5.0	ns	3-11	
t <sub>rec</sub>	Recovery Time	7.0			9.0		8.0	ns	3-11	
	MR to CP									

# 54F/74F219

64-Bit Random Access Memory  
(With 3-State Outputs)

### Description

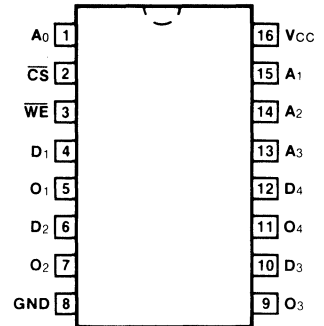
The 'F219 is a high-speed 64-bit RAM organized as a 16-word by 4-bit array. Address inputs are buffered to minimize loading and are fully decoded on-chip. The outputs are 3-state and are in the high-impedance state whenever the Chip Select ( $\overline{CS}$ ) input is HIGH. The outputs are active only in the Read mode. This device is similar to the 'F189 but features non-inverting, rather than inverting, data outputs.

- 3-State Outputs for Data Bus Applications
- Buffered Inputs Minimize Loading
- Address Decoding On-chip
- Diode Clamped Inputs Minimize Ringing

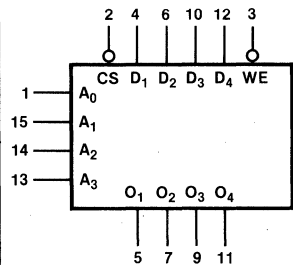
**Ordering Code:** See Section 6

Pkgs	Commercial Grade	Military Grade	Pkg Type
	$V_{CC} = +5.0\text{ V} \pm 5\%$ , $T_A = 0^\circ\text{ C to } +70^\circ\text{ C}$	$V_{CC} = +5.0\text{ V} \pm 10\%$ , $T_A = -55^\circ\text{ C to } +125^\circ\text{ C}$	
Plastic DIP (P)	74F219PC		9B
Ceramic DIP (D)	74F219DC	54F219DM	6B
Flatpak (F)		54F219FM	4L

### Connection Diagram



### Logic Symbol



$V_{CC}$  = Pin 16  
GND = Pin 8

**Input Loading/Fan-Out:** See Section 3 for U.L. definitions

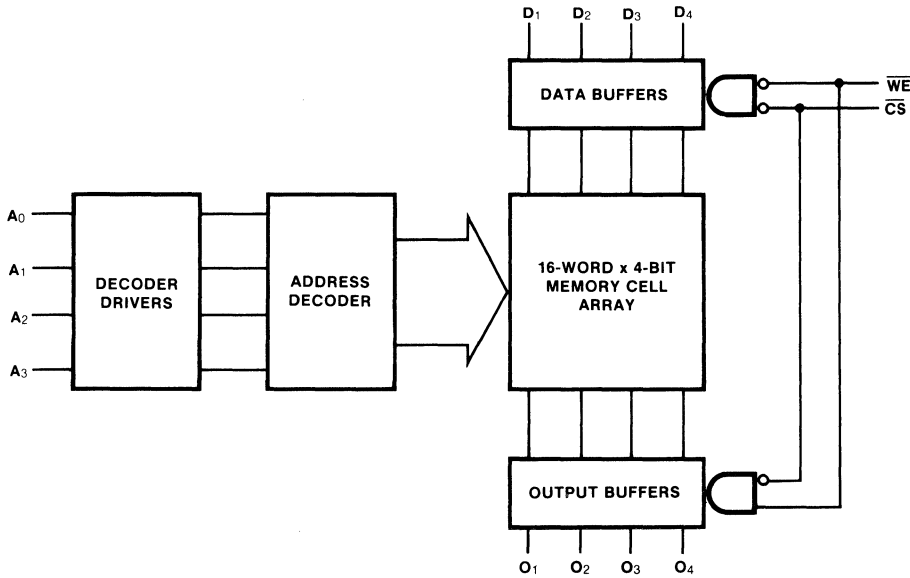
Pin Names	Description	54F/74F (U.L.) HIGH/LOW
$A_0 - A_3$	Address Inputs	0.5/0.375
$\overline{CS}$	Chip Select Input (Active LOW)	0.5/0.75
$\overline{WE}$	Write Enable Input (Active LOW)	0.5/0.75
$D_1 - D_4$	Data Inputs	0.5/0.375
$O_1 - O_4$	3-State Data Outputs	25/12.5

Function Table

INPUTS		OPERATION	CONDITION OF OUTPUTS
$\overline{CS}$	$\overline{WE}$		
L	L	Write	High Impedance
L	H	Read	Complement of Stored Data
H	X	Inhibit	High Impedance

H = HIGH Voltage Level  
 L = LOW Voltage Level  
 X = Immaterial

Logic Diagram



## DC Characteristics over Operating Temperature Range (unless otherwise specified)

Symbol	Parameter	54F/74F			Units	Conditions
		Min	Typ	Max		
I <sub>CC</sub>	Power Supply Current		37	55	mA	V <sub>CC</sub> = Max; $\overline{WE}$ , $\overline{CS}$ , Gnd

## AC Characteristics: See Section 3 for waveforms and load configurations

Symbol	Parameter	54F/74F			54F		74F		Units	Fig. No.
		T <sub>A</sub> = +25°C, V <sub>CC</sub> = +5.0 V C <sub>L</sub> = 50 pF			T <sub>A</sub> , V <sub>CC</sub> = Mil C <sub>L</sub> = 50 pF		T <sub>A</sub> , V <sub>CC</sub> = Com C <sub>L</sub> = 50 pF			
		Min	Typ	Max	Min	Max	Min	Max		
t <sub>PLH</sub> t <sub>PHL</sub>	Access Time, HIGH or LOW A <sub>n</sub> to O <sub>n</sub>	8.0	12	15.5					ns	3-1 3-10
t <sub>PZH</sub> t <sub>PZL</sub>	Access Time, HIGH or LOW $\overline{CS}$ to O <sub>n</sub>	3.5	5.0	6.5					ns	3-1, 3-12 3-13
t <sub>PHZ</sub> t <sub>PLZ</sub>	Disable Time, HIGH or LOW $\overline{CS}$ to O <sub>n</sub>	2.0	3.5	4.7					ns	3-1, 3-12 3-13
t <sub>PZH</sub> t <sub>PZL</sub>	Write Recovery Time, HIGH or LOW $\overline{WE}$ to O <sub>n</sub>	9.0	13.5	17					ns	3-1, 3-12 3-13
t <sub>PHZ</sub> t <sub>PLZ</sub>	Disable Time, HIGH or LOW $\overline{WE}$ to O <sub>n</sub>	3.5	5.0	6.5					ns	3-1, 3-12 3-13

## AC Operating Requirements: See Section 3 for waveforms

Symbol	Parameter	54F/74F			54F		74F		Units	Fig. No.
		T <sub>A</sub> = +25°C, V <sub>CC</sub> = +5.0 V			T <sub>A</sub> , V <sub>CC</sub> = Mil		T <sub>A</sub> , V <sub>CC</sub> = Com			
		Min	Typ	Max	Min	Max	Min	Max		
t <sub>s</sub> (H) t <sub>s</sub> (L)	Setup Time, HIGH or LOW A <sub>n</sub> to $\overline{WE}$	0							ns	3-16
t <sub>h</sub> (H) t <sub>h</sub> (L)	Hold Time, HIGH or LOW A <sub>n</sub> to $\overline{WE}$	0								
t <sub>s</sub> (H) t <sub>s</sub> (L)	Setup Time, HIGH or LOW D <sub>n</sub> to $\overline{WE}$	10							ns	3-14
t <sub>h</sub> (H) t <sub>h</sub> (L)	Hold Time, HIGH or LOW D <sub>n</sub> to $\overline{WE}$	0								
t <sub>s</sub> (L)	Setup Time LOW $\overline{CS}$ to $\overline{WE}$	6.0							ns	3-14
t <sub>h</sub> (L)	Hold Time, LOW $\overline{CS}$ to $\overline{WE}$	0							ns	3-14
t <sub>w</sub> (L)	$\overline{WE}$ Pulse Width LOW	6.0							ns	3-16

■ Test limits in screened columns are preliminary.

# 54F/74F240 • 54F/74F241 • 54F/74F244

Octal Buffer/Line Driver  
(With 3-State Outputs)

### Description

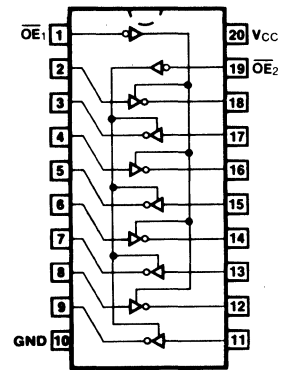
The 'F240, 'F241 and 'F244 are octal buffers and line drivers designed to be employed as memory address drivers, clock drivers and bus oriented transmitters/receivers which provide improved PC board density.

- Hysteresis at Inputs to Improve Noise Margins
- 3-State Outputs Drive Bus Lines or Buffer Memory Address Registers
- Outputs Sink 64 mA
- 15 mA Source Current
- Input Clamp Diodes Limit High-speed Termination Effects

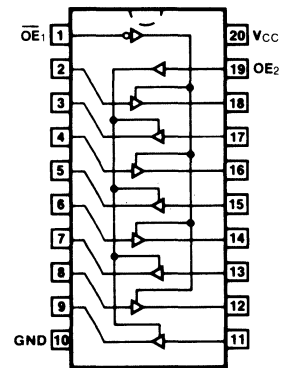
Ordering Code: See Section 6

Pkgs	Commercial Grade	Military Grade	Pkg Type
	$V_{CC} = +5.0\text{ V} \pm 5\%$ , $T_A = 0^\circ\text{ C to } +70^\circ\text{ C}$	$V_{CC} = +5.0\text{ V} \pm 10\%$ , $T_A = -55^\circ\text{ C to } +125^\circ\text{ C}$	
Plastic DIP (P)	74F240PC, 74F241PC 74F244PC		9Z
Ceramic DIP (D)	74F240DC, 74F241DC 74F244DC	54F240DM, 54F241DM 54F244DM	4E
Flatpak (F)		54F240FM, 54F241FM 54F244FM	4D

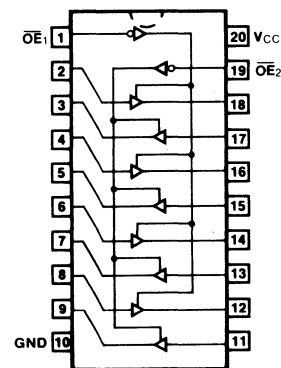
Connection Diagrams  
'F240



'F241



'F244



Input Loading/Fan-Out: See Section 3 for U.L. definitions

Pin Names	Description	54F/74F (U.L.) HIGH/LOW
$\overline{OE}_1, \overline{OE}_2$	3-State Output Enable Input (Active LOW)	0.5/0.625
$OE_2$	3-State Output Enable Input (Active HIGH)	0.5/0.625
	Inputs ('F240)	0.5/0.625*
	Inputs ('F241, 'F244)	0.5/1.0*
	Outputs	75/40 (30)

\*Worst-case ('F240 enabled; 'F241, 'F244 disabled)

## Truth Tables

'F240		
INPUTS		OUTPUT
$\overline{OE}_1, \overline{OE}_2$	D	
L	L	H
L	H	L
H	X	Z

'F241			
INPUTS			OUTPUT
$\overline{OE}_1$	$OE_2$	D	
L	H	L	L
L	H	H	H
H	L	X	Z

'F244		
INPUTS		OUTPUT
$\overline{OE}_1, \overline{OE}_2$	D	
L	L	L
L	H	H
H	X	Z

H = HIGH Voltage Level

L = LOW Voltage Level

X = Immaterial

Z = High Impedance

## DC Characteristics over Operating Temperature Range (unless otherwise specified)

Symbol	Parameter		54F/74F			Units	Conditions	
			Min	Typ	Max			
VOH	Output HIGH Voltage	XM, XC	2.4			V	$I_{OH} = -3.0 \text{ mA}, V_{CC} = \text{Min}$ $V_{IN} = V_{IH} \text{ or } V_{IL}$	
		XM	2.0			V	$V_{IH} = 2.0 \text{ V}$ $V_{CC} = \text{Min}$ $V_{IL} = 0.5 \text{ V}$	
		XC	2.0					
VOL	Output LOW Voltage	XM	0.55			V	$V_{IN} = V_{IH}$ or $V_{IL}$ $V_{CC} = \text{Min}$	
		XC	0.55					
$V_{T+} - V_{T-}$	Hysteresis Voltage		0.2	0.4		V	$V_{CC} = \text{Min}$	
IOS	Output Short-circuit Current		-100		-225	mA	$V_{CC} = \text{Max}, V_{OUT} = 0 \text{ V}$	
ICCH	Power Supply Current	'F240	19	29		mA	Outputs HIGH	$V_{CC} = \text{Max}$
ICCL		'F241, 'F244	40	60		mA	Outputs LOW	
		'F240	50	75				
ICCZ		'F241, 'F244	60	90		mA	Outputs OFF	
	'F240	42	63					
	'F241, 'F244	60	90					

## AC Characteristics: See Section 3 for waveforms and load configurations

Symbol	Parameter	54F/74F			54F		74F		Units	Fig. No.
		$T_A = +25^\circ\text{C}, V_{CC} = +5.0 \text{ V}, C_L = 50 \text{ pF}$			$T_A, V_{CC} = \text{Mil}, C_L = 50 \text{ pF}$		$T_A, V_{CC} = \text{Com}, C_L = 50 \text{ pF}$			
		Min	Typ	Max	Min	Max	Min	Max		
tPLH	Propagation Delay Data to Output ('F240)	3.0	5.1	7.0	3.0	9.0	3.0	8.0	ns	3-1 3-3
tPHL		2.0	3.5	4.7	2.0	6.0	2.0	5.7		
tPZH	Output Enable Time ('F240)	2.0	3.5	4.7	2.0	6.5	2.0	5.7	ns	3-1 3-12
tPZL		4.0	6.9	9.0	4.0	10.5	4.0	10		
tPHZ	Output Disable Time ('F240)	2.0	4.0	5.3	2.0	6.5	2.0	6.3	ns	3-13
tPLZ		2.0	6.0	8.0	2.0	12.5	2.0	9.5		
tPLH	Propagation Delay Data to Output ('F241, 'F244)	2.5	4.0	5.2	2.5	6.5	2.5	6.2	ns	3-1 3-4
tPHL		2.5	4.0	5.2	2.5	7.0	2.5	6.5		
tPZH	Output Enable Time ('F241, 'F244)	2.0	4.3	5.7	2.0	7.0	2.0	6.7	ns	3-1 3-12
tPZL		2.0	5.4	7.0	2.0	8.5	2.0	8.0		
tPHZ	Output Disable Time ('F241, 'F244)	2.0	4.5	6.0	2.0	7.0	2.0	7.0	ns	3-13
tPLZ		2.0	4.5	6.0	2.0	7.5	2.0	7.0		

# 54F/74F242 • 54F/74F243

Quad Bus Transceiver  
(With 3-State Outputs)

## Description

The 'F242 and 'F243 are quad bus transmitters/receivers designed for 4-line asynchronous 2-way data communications between data busses.

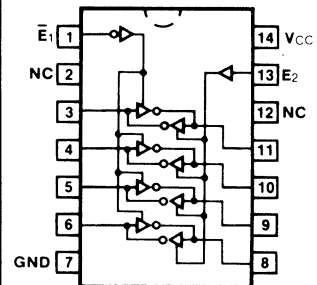
- Hysteresis at Inputs to Improve Noise Immunity
- 2-Way Asynchronous Data Bus Communication
- Input Clamp Diodes Limit High-speed Termination Effects

Ordering Code: See Section 6

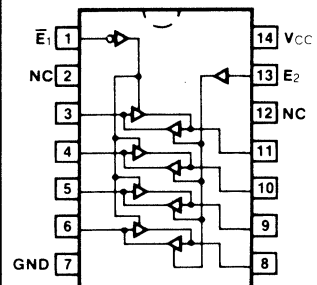
Pkgs	Commercial Grade	Military Grade	Pkg Type
	$V_{CC} = +5.0\text{ V} \pm 5\%$ , $T_A = 0^\circ\text{C to } +70^\circ\text{C}$	$V_{CC} = +5.0\text{ V} \pm 10\%$ , $T_A = -55^\circ\text{C to } +125^\circ\text{C}$	
Plastic DIP (P)	74F242PC, 74F243PC		9A
Ceramic DIP (D)	74F242DC, 74F243DC	54F242DM, 54F243DM	6A
Flatpak (F)		54F242FM, 54F243FM	3I

## Connection Diagrams

'F242



'F243



Input Loading/Fan-Out: See Section 3 for U.L. definitions

Pin Names	Description	54F/74F (U.L.) HIGH/LOW
$\bar{E}_1$	Enable Input (Active LOW)	0.5/0.625
$E_2$	Enable Input (Active HIGH)	0.5/0.625
	Inputs ('F242)	1.75/0.625*
	Inputs ('F243)	1.75/1.0*
	Outputs	75/40 (30)

\*Worst-case ('F242 enabled, 'F243 disabled)



Truth Tables

'F242

INPUTS		OUTPUT
$\bar{E}_1$	D	
L	L	H
L	H	L
H	X	Z

'F243

INPUTS		OUTPUT
$\bar{E}_1$	D	
L	L	L
L	H	H
H	X	Z

INPUTS		OUTPUT
$E_2$	D	
L	X	Z
H	L	H
H	H	L

INPUTS		OUTPUT
$E_2$	D	
L	X	Z
H	L	L
H	H	H

H = HIGH Voltage Level    L = LOW Voltage Level    X = Immaterial    Z = High Impedance

DC Characteristics over Operating Temperature Range (unless otherwise specified)

Symbol	Parameter		54F/74F			Units	Conditions	
			Min	Typ	Max			
VOH	Output HIGH Voltage	XM, XC	2.4		V	IOH = -3.0 mA, VCC = Min VIN = VIH or VIL		
		XM	2.0			V	VIH = 2.0 V VCC = Min VIL = 0.5 V	
		XC	2.0					
VOL	Output LOW Voltage	XM	0.55		V	IOL = 48 mA IOL = 64 mA	VIN = VIH or VIL VCC = Min	
		XC	0.55					
VT+ - VT-	Hysteresis Voltage		0.2	0.4	V	VCC = Min		
IiH	Input HIGH Current Breakdown Test, All Data Inputs				100	μA	VOUT = 5.5 V, VCC = Max	
IoZH	Output OFF Current HIGH				70 100	μA	VOUT = 2.7 V	VIN = VIH or VIL VCC = Max
							VOUT = 5.5 V	
IoZL	Output OFF Current LOW				-1.6	mA	VCC = Max, VIN = VIH or VIL VOUT = 0.4 V	
Ios	Output Short-circuit Current				-100	-225	mA	VCC = Max, VOUT = 0 V
IcCH	Power Supply Current		'F242	30	46	mA	Outputs HIGH	VCC = Max
			'F243	64	80			
IcCL	Power Supply Current		'F242	46	69	mA	Outputs LOW	
			'F243	64	90			
IcCZ	Power Supply Current		'F242	42	63	mA	Outputs OFF	
			'F243	71	90			

**AC Characteristics:** See Section 3 for waveforms and load configurations

Symbol	Parameter	54F/74F			54F		74F		Units	Fig. No.
		T <sub>A</sub> = +25°C, V <sub>CC</sub> = +5.0 V C <sub>L</sub> = 50 pF			T <sub>A</sub> , V <sub>CC</sub> = Mil C <sub>L</sub> = 50 pF		T <sub>A</sub> , V <sub>CC</sub> = Com C <sub>L</sub> = 50 pF			
		Min	Typ	Max	Min	Max	Min	Max		
t <sub>PLH</sub>	Propagation Delay Data to Output ('F242)	3.0	5.1	7.0			3.0	8.0	ns	3-1 3-3
t <sub>PHL</sub>		2.0	3.5	4.7			2.0	5.7		
t <sub>PZH</sub>	Output Enable Time ('F242)	2.0	3.5	4.7			2.0	5.7	ns	3-1 3-12 3-13
t <sub>PZL</sub>		4.0	6.9	9.0			4.0	10		
t <sub>PHZ</sub>	Output Disable Time ('F242)	2.0	4.0	5.3			2.0	6.3	ns	3-1 3-4
t <sub>PLZ</sub>		2.0	3.9	6.5			2.0	8.0		
t <sub>PLH</sub>	Propagation Delay Data to Output ('F243)	2.5	4.0	5.2	2.0	6.5	2.0	6.2	ns	3-1 3-4
t <sub>PHL</sub>		2.5	4.0	5.2	2.0	8.5	2.0	6.5		
t <sub>PZH</sub>	Output Enable Time ('F243)	2.0	4.3	5.7	2.0	8.0	2.0	6.7	ns	3-1 3-12 3-13
t <sub>PZL</sub>		2.0	5.8	7.5	2.0	10.5	2.0	8.5		
t <sub>PHZ</sub>	Output Disable Time ('F243)	2.0	4.5	6.0	2.0	7.5	2.0	7.0	ns	3-1 3-12 3-13
t <sub>PLZ</sub>		2.0	4.5	6.0	2.0	8.5	2.0	7.0		

## 54F/74F245

### Octal Bidirectional Transceiver

(With 3-State Inputs/Outputs)

#### Description

The 'F245 contains eight non-inverting bidirectional buffers with 3-state outputs and is intended for bus-oriented applications. Current sinking capability is 20 mA at the A ports and 64 mA at the B ports. The transmit/Receive (T/R) input determines the direction of data flow through the bidirectional transceiver. Transmit (active HIGH) enables data from A ports to B ports; Receive (active LOW) enables data from B ports to A ports. The Output Enable input, when HIGH, disables both A and B ports by placing them in a high-Z condition.

- Non-Inverting Buffers
- Bidirectional Data Path
- B Outputs Sink 64 mA
- Hysteresis on A and B Inputs
- MOS Compatible

Ordering Code: See Section 6

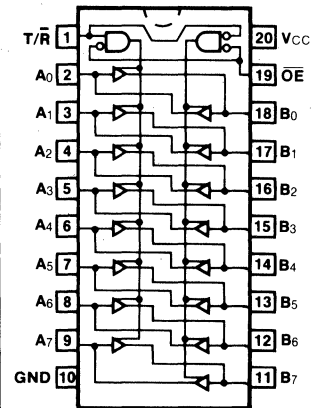
Pkgs	Commercial Grade	Military Grade	Pkg Type
	$V_{CC} = +5.0\text{ V} \pm 5\%$ , $T_A = 0^\circ\text{C to } +70^\circ\text{C}$	$V_{CC} = +5.0\text{ V} \pm 10\%$ , $T_A = -55^\circ\text{C to } +125^\circ\text{C}$	
Plastic DIP (P)	74F245PC		9Z
Ceramic DIP (D)	74F245DC	54F245DM	4E
Flatpak (F)		54F245FM	4D

Input Loading/Fan-Out: See Section 3 for U.L. definitions

Pin Names	Description	54F/74F (U.L.) HIGH/LOW
$\overline{OE}$	Output Enable Input (Active LOW)	0.5/1.0
T/R	Transmit/Receive Input	0.5/0.5
A <sub>0</sub> - A <sub>7</sub>	Side A 3-State Inputs or 3-State Outputs	1.75/0.625* 25/12.5
B <sub>0</sub> - B <sub>7</sub>	Side B 3-State Inputs or 3-State Outputs	1.75/0.625* 25/40 (30)

\*Worst-case (disabled)

#### Connection Diagram



#### Truth Table

INPUTS		OUTPUT
$\overline{OE}$	T/R	
L	L	Bus B Data to Bus A
L	H	Bus A Data to Bus B
H	X	High-Z State

H = HIGH Voltage Level

L = LOW Voltage Level

X = Immaterial

**DC Characteristics over Operating Temperature Range** (unless otherwise specified)

Symbol	Parameter		54F/74F			Units	Conditions	
			Min	Typ	Max			
V <sub>OH</sub>	Output HIGH Voltage B <sub>0</sub> - B <sub>7</sub>	XM	2.0			V	I <sub>OH</sub> = -12 mA I <sub>OH</sub> = -15 mA	V <sub>CC</sub> = Min
		XC	2.0					
	Output HIGH Voltage B <sub>0</sub> - B <sub>7</sub>	2.4			V	I <sub>OH</sub> = -3.0 mA		
V <sub>OL</sub>	Output LOW Voltage B <sub>0</sub> - B <sub>7</sub>	XM	0.55			V	I <sub>OL</sub> = 48 mA I <sub>OL</sub> = 64 mA	V <sub>CC</sub> = Min
		XC	0.55					
V <sub>T+</sub> - V <sub>T-</sub>	Hysteresis Voltage B <sub>0</sub> - B <sub>7</sub>		200	400		mV	V <sub>CC</sub> = Min	
I <sub>IH</sub>	Input HIGH Current Breakdown Test - A <sub>n</sub> , B <sub>n</sub>		1.0			mA	V <sub>CC</sub> = Max, V <sub>IN</sub> = 5.5 V	
I <sub>IH</sub> + I <sub>OZH</sub>	3-State Output OFF Current HIGH - A <sub>n</sub> , B <sub>n</sub>		70			μA	V <sub>CC</sub> = Max, V <sub>OUT</sub> = 2.4 V	
I <sub>IL</sub> + I <sub>OZL</sub>	3-State Output OFF Current LOW - A <sub>n</sub> , B <sub>n</sub>		1.0			mA	V <sub>CC</sub> = Max, V <sub>OUT</sub> = 0.5 V	
I <sub>OS</sub>	Output Short-circuit Current B <sub>0</sub> - B <sub>7</sub>		-100		-225	mA	V <sub>CC</sub> = Max, V <sub>OUT</sub> = 0 V	
I <sub>CC</sub>	Power Supply Current			95	143	mA	V <sub>CC</sub> = Max	

**AC Characteristics:** See Section 3 for waveforms and load configurations

Symbol	Parameter	54F/74F			54F		74F		Units	Fig. No.
		T <sub>A</sub> = +25°C, V <sub>CC</sub> = +5.0 V C <sub>L</sub> = 50 pF			T <sub>A</sub> , V <sub>CC</sub> = Mil C <sub>L</sub> = 50 pF		T <sub>A</sub> , V <sub>CC</sub> = Com C <sub>L</sub> = 50 pF			
		Min	Typ	Max	Min	Max	Min	Max		
t <sub>PLH</sub>	Propagation Delay A <sub>n</sub> to B <sub>n</sub> or B <sub>n</sub> to A <sub>n</sub>	2.5	4.2	5.5			2.5	6.5	ns	3-1
t <sub>PHL</sub>		2.5	4.6	6.0			2.5	7.0		3-4
t <sub>PZH</sub>	Output Enable Time	3.0	5.3	7.0			3.0	8.0	ns	3-1
t <sub>PZL</sub>		4.5	7.9	10			4.5	11		3-12
t <sub>PHZ</sub>	Output Disable Time	3.0	5.0	6.5			3.0	7.5	ns	3-13
t <sub>PLZ</sub>		2.0	3.7	5.0			2.0	6.0		

# 54F/74F251

8-Input Multiplexer  
(With 3-State Outputs)

**Description**

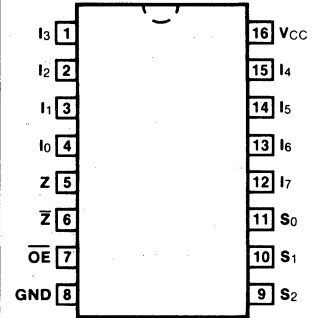
The 'F251 is a high-speed 8-input digital multiplexer. It provides, in one package, the ability to select one bit of data from up to eight sources. It can be used as universal function generator to generate any logic function of four variables. Both assertion and negation outputs are provided.

- Multifunctional Capability
- On-chip Select Logic Decoding
- Inverting and Non-inverting 3-State Outputs

**Ordering Code:** See Section 6

Pkgs	Commercial Grade	Military Grade	Pkg Type
	$V_{CC} = +5.0\text{ V} \pm 5\%$ , $T_A = 0^\circ\text{C to } +70^\circ\text{C}$	$V_{CC} = +5.0\text{ V} \pm 10\%$ , $T_A = -55^\circ\text{C to } +125^\circ\text{C}$	
Plastic DIP (P)	74F251PC		9B
Ceramic DIP (D)	74F251DC	54F251DM	6B
Flatpak (F)		54F251FM	4L

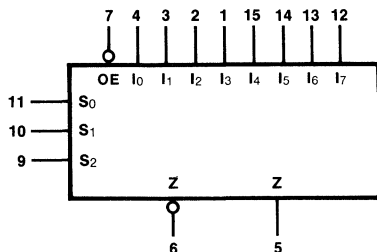
**Connection Diagram**



**Input Loading/Fan-Out:** See Section 3 for U.L. definitions

Pin Names	Description	54F/74F (U.L.) HIGH/LOW
$S_0 - S_2$	Select Inputs	0.5/0.375
$\overline{OE}$	3-State Output Enable Input (Active LOW)	0.5/0.375
$I_0 - I_7$	Multiplexer Inputs	0.5/0.375
Z	3-State Multiplexer Output	25/12.5
$\overline{Z}$	Complementary 3-State Multiplexer Output	25/12.5

**Logic Symbol**



$V_{CC} = \text{Pin } 16$   
 $GND = \text{Pin } 8$

### Functional Description

This device is a logical implementation of a single-pole, 8-position switch with the switch position controlled by the state of three Select inputs,  $S_0$ ,  $S_1$ ,  $S_2$ . Both assertion and negation outputs are provided. The Output Enable input ( $\overline{OE}$ ) is active LOW. When it is activated, the logic function provided at the output is:

$$Z = \overline{OE} \cdot (I_0 \cdot \overline{S_0} \cdot \overline{S_1} \cdot \overline{S_2} + I_1 \cdot S_0 \cdot \overline{S_1} \cdot \overline{S_2} + I_2 \cdot \overline{S_0} \cdot S_1 \cdot \overline{S_2} + I_3 \cdot S_0 \cdot S_1 \cdot \overline{S_2} + I_4 \cdot \overline{S_0} \cdot \overline{S_1} \cdot S_2 + I_5 \cdot S_0 \cdot \overline{S_1} \cdot S_2 + I_6 \cdot \overline{S_0} \cdot S_1 \cdot S_2 + I_7 \cdot S_0 \cdot S_1 \cdot S_2)$$

When the Output Enable is HIGH, both outputs are in the high impedance (high Z) state. This feature allows multiplexer expansion by tying the outputs of up to 128 devices together. When the outputs of the 3-state devices are tied together, all but one device must be in the high impedance state to avoid high currents that would exceed the maximum ratings. The Output Enable signals should be designed to ensure there is no overlap in the active LOW portion of the enable voltages.

### Truth Table

INPUTS			OUTPUTS	
$\overline{OE}$	$S_2$	$S_1$	$\overline{Z}$	Z
H	X	X	Z	Z
L	L	L	$\overline{I_0}$	$I_0$
L	L	L	$\overline{I_1}$	$I_1$
L	L	H	$\overline{I_2}$	$I_2$
L	L	H	$\overline{I_3}$	$I_3$
L	H	L	$\overline{I_4}$	$I_4$
L	H	L	$\overline{I_5}$	$I_5$
L	H	H	$\overline{I_6}$	$I_6$
L	H	H	$\overline{I_7}$	$I_7$

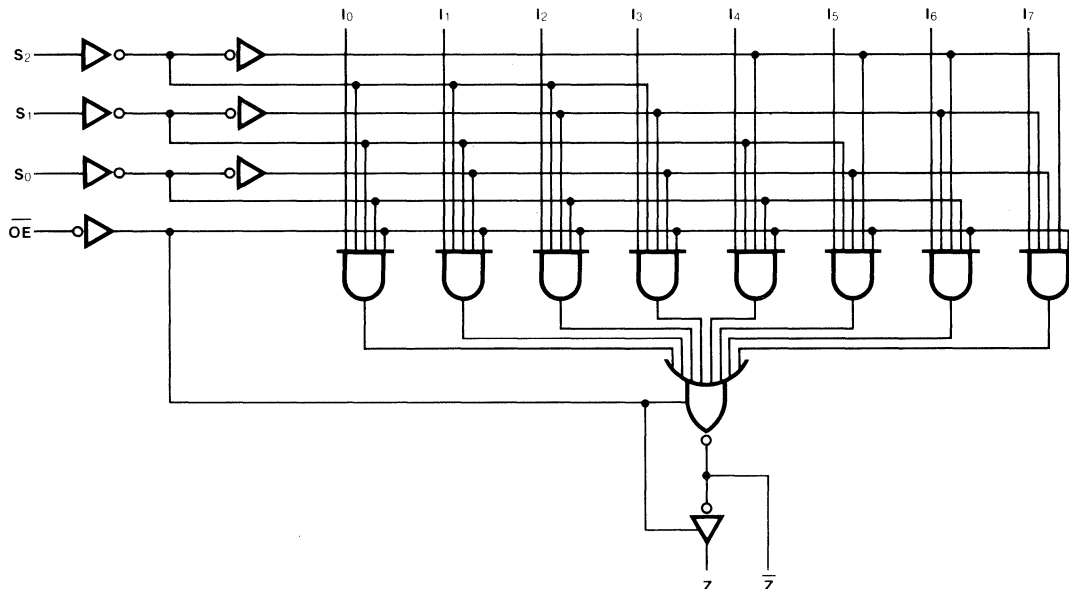
H = HIGH Voltage Level

L = LOW Voltage Level

X = Immaterial

Z = High Impedance

### Logic Diagram



**DC Characteristics over Operating Temperature Range** (unless otherwise specified)

Symbol	Parameter		54F/74F			Units	Conditions	
			Min	Typ	Max			
I <sub>CC</sub>	Power Supply Current	ON	15	22	mA	I <sub>n</sub> , S <sub>n</sub> = 4.5 V OE = Gnd	V <sub>CC</sub> = Max	
		OFF	16	24				OE, I <sub>n</sub> = 4.5 V

**AC Characteristics:** See Section 3 for waveforms and load configurations

Symbol	Parameter	54F/74F			54F		74F		Units	Fig. No.
		T <sub>A</sub> = +25°C, V <sub>CC</sub> = +5.0 V C <sub>L</sub> = 50 pF			T <sub>A</sub> , V <sub>CC</sub> = Mil C <sub>L</sub> = 50 pF		T <sub>A</sub> , V <sub>CC</sub> = Com C <sub>L</sub> = 50 pF			
		Min	Typ	Max	Min	Max	Min	Max		
t <sub>PLH</sub> t <sub>PHL</sub>	Propagation Delay S <sub>n</sub> to Z <sub>n</sub>	4.0 3.2	5.9 5.7	8.0 7.5	3.5 3.2	9.5 9.5	4.0 3.2	9.0 8.5	ns	3-1 3-10
t <sub>PLH</sub> t <sub>PHL</sub>	Propagation Delay S <sub>n</sub> to Z <sub>n</sub>	4.5 5.0	9.6 6.9	13 9.0	3.5 3.0	16.5 10.5	4.5 4.0	14 10	ns	3-1 3-10
t <sub>PLH</sub> t <sub>PHL</sub>	Propagation Delay I <sub>n</sub> to Z	3.0 2.0	4.1 3.0	5.7 4.0	2.5 2.0	8.0 6.0	3.0 2.0	7.0 5.0	ns	3-1 3-3
t <sub>PLH</sub> t <sub>PHL</sub>	Propagation Delay I <sub>n</sub> to Z	5.5 3.7	7.2 5.1	9.5 6.5	3.5 3.7	11.5 7.5	5.5 3.7	10.5 7.5	ns	3-1 3-4
t <sub>PZH</sub> t <sub>PZL</sub>	Output Enable Time OE to Z	3.0 3.5	5.4 6.4	7.0 8.5	3.0 3.5	9.5 10.5	3.0 3.5	8.0 9.5	ns	3-1 3-12 3-13
t <sub>PHZ</sub> t <sub>PLZ</sub>	Output Disable Time OE to Z	3.0 2.0	5.0 3.2	6.5 4.5	3.0 2.0	8.5 7.5	3.0 2.0	7.5 5.5		
t <sub>PZH</sub> t <sub>PZL</sub>	Output Enable Time OE to Z	4.0 3.5	6.9 6.0	9.0 8.0	4.0 3.5	10 10	4.0 3.5	10 9.0	ns	3-1 3-12 3-13
t <sub>PHZ</sub> t <sub>PLZ</sub>	Output Disable Time OE to Z	3.0 2.0	4.7 3.5	6.0 4.5	3.0 2.0	7.0 5.5	3.0 2.0	7.0 5.5		

# 54F/74F253

## Dual 4-Input Multiplexer

(With 3-State Outputs)

### Description

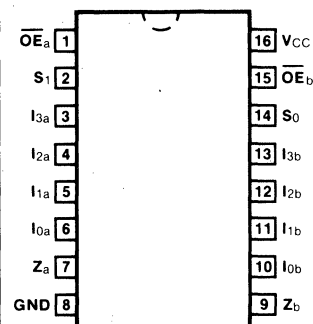
The 'F253 is a dual 4-input multiplexer with 3-state outputs. It can select two bits of data from four sources using common select inputs. The outputs may be individually switched to a high-impedance state with a HIGH on the respective Output Enable ( $\overline{OE}$ ) inputs, allowing the outputs to interface directly with bus oriented systems.

- **FAST Process for High Speed**
- **Multifunction Capability**
- **Non-inverting 3-State Outputs**

**Ordering Code:** See Section 6

Pkgs	Commercial Grade	Military Grade	Pkg Type
	$V_{CC} = +5.0\text{ V} \pm 5\%$ , $T_A = 0^\circ\text{C to } +70^\circ\text{C}$	$V_{CC} = +5.0\text{ V} \pm 10\%$ , $T_A = -55^\circ\text{C to } +125^\circ\text{C}$	
Plastic DIP (P)	74F253PC		9B
Ceramic DIP (D)	74F253DC	54F253DM	6B
Flatpak (F)		54F253FM	4L

### Connection Diagram

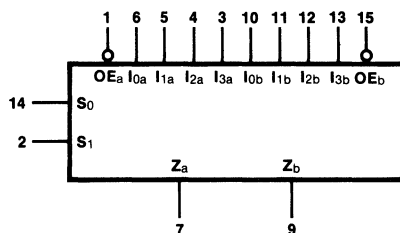


4

**Input Loading/Fan-Out:** See Section 3 for U.L. definitions

Pin Names	Description	54F/74F (U.L.) HIGH/LOW
$I_{0a} - I_{3a}$	Side A Data Inputs	0.5/0.375
$I_{0b} - I_{3b}$	Side B Data Inputs	0.5/0.375
$S_0, S_1$	Common Select Inputs	0.5/0.375
$\overline{OE}_a$	Side A Output Enable Input (Active LOW)	0.5/0.375
$\overline{OE}_b$	Side B Output Enable Input (Active LOW)	0.5/0.375
$Z_a, Z_b$	3-State Outputs	25/12.5

### Logic Symbol



$V_{CC}$  = Pin 16  
GND = Pin 8



**Functional Description**

This device contains two identical 4-input multiplexers with 3-state outputs. They select two bits from four sources selected by common Select inputs ( $S_0, S_1$ ). The 4-input multiplexers have individual Output Enable ( $\overline{OE}_a, \overline{OE}_b$ ) inputs which, when HIGH, force the outputs to a high-impedance (high-Z) state. This device is the logic implementation of a 2-pole, 4-position switch, where the position of the switch is determined by the logic levels supplied to the two select inputs. The logic equations for the outputs are shown below:

$$Z_a = \overline{OE}_a \cdot (I_{0a} \cdot \overline{S_1} \cdot \overline{S_0} + I_{1a} \cdot \overline{S_1} \cdot S_0 + I_{2a} \cdot S_1 \cdot \overline{S_0} + I_{3a} \cdot S_1 \cdot S_0)$$

$$Z_b = \overline{OE}_b \cdot (I_{0b} \cdot \overline{S_1} \cdot \overline{S_0} + I_{1b} \cdot \overline{S_1} \cdot S_0 + I_{2b} \cdot S_1 \cdot \overline{S_0} + I_{3b} \cdot S_1 \cdot S_0)$$

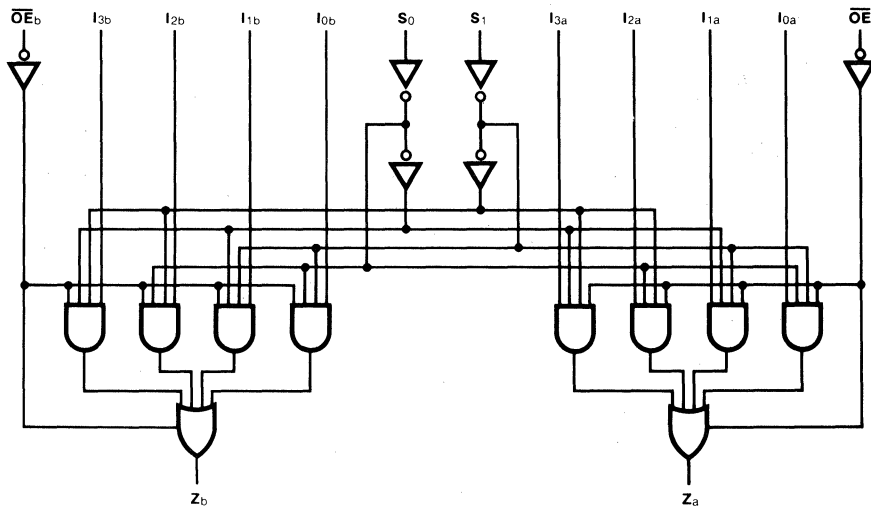
If the outputs of 3-state devices are tied together, all but one device must be in the high-impedance state to avoid high currents that would exceed the maximum ratings. Designers should ensure that Output Enable signals to 3-state devices whose outputs are tied together are designed so that there is no overlap.

**Truth Table**

SELECT INPUTS		DATA INPUTS				OUTPUT ENABLE	OUTPUT
$S_0$	$S_1$	$I_0$	$I_1$	$I_2$	$I_3$	$\overline{OE}$	Z
X	X	X	X	X	X	H	(Z)
L	L	L	X	X	X	L	L
L	L	H	X	X	X	L	H
H	L	X	L	X	X	L	L
H	L	X	H	X	X	L	H
L	H	X	X	L	X	L	L
L	H	X	X	H	X	L	H
H	H	X	X	X	L	L	L
H	H	X	X	X	H	L	H

Address inputs  $S_0$  and  $S_1$  are common to both sections.  
 H = HIGH Voltage Level  
 L = LOW Voltage Level  
 X = Immaterial  
 (Z) = High Impedance

**Logic Diagram**



**DC Characteristics over Operating Temperature Range** (unless otherwise specified)

Symbol	Parameter	54F/74F			Units	Conditions
		Min	Typ	Max		
ICCH	Power Supply Current		11.5	16	mA	$V_{CC} = \text{Max}, \overline{OE}_n = \text{Gnd}$ $I_0, S_n = 4.5 \text{ V}; I_1 - I_3 = \text{Gnd}$
ICCL			16	23		$V_{CC} = \text{Max}$ $I_n, S_n, \overline{OE}_n = \text{Gnd}$
ICCZ			16	23		$V_{CC} = \text{Max}, \overline{OE}_n = 4.5 \text{ V}$ $I_n, S_n = \text{Gnd}$

**AC Characteristics:** See Section 3 for waveforms and load configurations

Symbol	Parameter	54F/74F			54F		74F		Units	Fig. No.
		$T_A = +25^\circ\text{C},$ $V_{CC} = +5.0 \text{ V}$ $C_L = 50 \text{ pF}$			$T_A, V_{CC} =$ Mil $C_L = 50 \text{ pF}$		$T_A, V_{CC} =$ Com $C_L = 50 \text{ pF}$			
		Min	Typ	Max	Min	Max	Min	Max		
tPLH	Propagation Delay $S_n$ to $Z_n$	5.5	10.1	12.5	3.5	15	4.5	13.5	ns	3-1
tPHL		4.5	9.2	11	2.5	12	3.5	12		3-10
tPLH	Propagation Delay $I_n$ to $Z_n$	3.0	5.5	7.0	2.5	9.0	3.0	8.0	ns	3-1
tPHL		3.0	5.5	7.0	2.5	8.0	3.0	8.0		3-4
tpZH	Output Enable Time	3.0	6.8	9.0	2.5	10.5	3.0	10	ns	3-1
tpZL		3.0	7.2	9.5	2.5	11	3.0	10.5		3-12
tpHZ	Output Disable Time	2.0	3.7	5.0	2.0	6.5	2.0	6.0	ns	3-13
tpLZ		2.0	4.4	6.0	2.0	9.0	2.0	7.0		

■ Test limits in screened columns are preliminary.

# 54F/74F257

Quad 2-Input Multiplexer  
(With 3-State Outputs)

**Description**

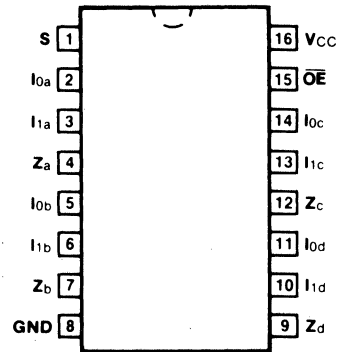
The 'F257 is a quad 2-input multiplexer with 3-state outputs. Four bits of data from two sources can be selected using a Common Data Select input. The four outputs present the selected data in true (non-inverted) form. The outputs may be switched to a high impedance state with a HIGH on the common Output Enable ( $\overline{OE}$ ) input, allowing the outputs to interface directly with bus oriented systems.

- Multiplexer Expansion by Tying Outputs Together
- Non-inverting 3-State Outputs
- Input Clamp Diodes Limit High-speed Termination Effects

**Ordering Code:** See Section 6

Pkgs	Commercial Grade	Military Grade	Pkg Type
	$V_{CC} = +5.0\text{ V} \pm 5\%$ , $T_A = 0^\circ\text{C to } +70^\circ\text{C}$	$V_{CC} = +5.0\text{ V} \pm 10\%$ , $T_A = -55^\circ\text{C to } +125^\circ\text{C}$	
Plastic DIP (P)	74F257PC		9B
Ceramic DIP (D)	74F257DC	54F257DM	6B
Flatpak (F)		54F257FM	4L

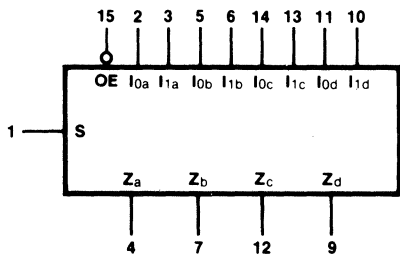
**Connection Diagram**



**Input Loading/Fan-Out:** See Section 3 for U.L. definitions

Pin Names	Description	54F/74F (U.L.) HIGH/LOW
S	Common Data Select Input	0.5/0.375
$\overline{OE}$	3-State Output Enable Input (Active LOW)	0.5/0.375
$I_{0a} - I_{0d}$	Data Inputs from Source 0	0.5/0.375
$I_{1a} - I_{1d}$	Data Inputs from Source 1	0.5/0.375
$Z_a - Z_d$	3-State Multiplexer Outputs	25/12.5

**Logic Symbol**



$V_{CC}$  = Pin 16  
GND = Pin 8

**Functional Description**

The 'F257 is a quad 2-input multiplexer with 3-state outputs. It selects four bits of data from two sources under control of a Common Data Select input. When the Select input is LOW, the  $I_{0x}$  inputs are selected and when Select is HIGH, the  $I_{1x}$  inputs are selected. The data on the selected inputs appears at the outputs in true (non-inverted) form. The device is the logic implementation of a 4-pole, 2-position switch where the position of the switch is determined by the logic levels supplied to the Select input. The logic equations for the outputs are shown below:

$$Z_a = \overline{OE} \cdot (I_{1a} \cdot S + I_{0a} \cdot \overline{S})$$

$$Z_b = \overline{OE} \cdot (I_{1b} \cdot S + I_{0b} \cdot \overline{S})$$

$$Z_c = \overline{OE} \cdot (I_{1c} \cdot S + I_{0c} \cdot \overline{S})$$

$$Z_d = \overline{OE} \cdot (I_{1d} \cdot S + I_{0d} \cdot \overline{S})$$

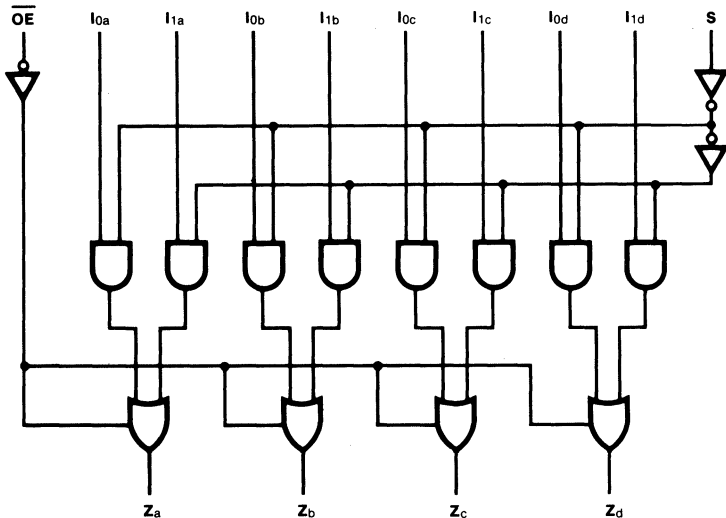
When the Output Enable input ( $\overline{OE}$ ) is HIGH, the outputs are forced to a high impedance OFF state. If the outputs are tied together, all but one device must be in the high impedance state to avoid high currents that would exceed the maximum ratings. Designers should ensure the Output Enable signals to 3-state devices whose outputs are tied together are designed so there is no overlap.

**Truth Table**

OUTPUT ENABLE	SELECT INPUT	DATA INPUTS		OUTPUTS
$\overline{OE}$	S	$I_0$	$I_1$	Z
H	X	X	X	(Z)
L	H	X	L	L
L	H	X	H	H
L	L	L	X	L
L	L	H	X	H

H = HIGH Voltage Level  
 L = LOW Voltage Level  
 X = Immaterial  
 (Z) = High Impedance

**Logic Diagram**



**DC Characteristics over Operating Temperature Range** (unless otherwise specified)

Symbol	Parameter		54F/74F			Units	Conditions
			Min	Typ	Max		
I <sub>CC</sub>	Power Supply Current	HIGH	9.0	15	mA	V <sub>CC</sub> = Max; S, I <sub>1x</sub> = 4.5 V OE, I <sub>0x</sub> = Gnd	
		LOW	14.5	22		V <sub>CC</sub> = Max; I <sub>1x</sub> = 4.5 V OE, I <sub>0x</sub> , S = Gnd	
		OFF	15	23		V <sub>CC</sub> = Max; S, I <sub>0x</sub> = Gnd OE, I <sub>1x</sub> = 4.5 V	

**AC Characteristics:** See Section 3 for waveforms and load configurations

Symbol	Parameter	54F/74F			54F		74F		Units	Fig. No.
		T <sub>A</sub> = +25°C, V <sub>CC</sub> = +5.0 V C <sub>L</sub> = 50 pF			T <sub>A</sub> , V <sub>CC</sub> = Mil C <sub>L</sub> = 50 pF		T <sub>A</sub> , V <sub>CC</sub> = Com C <sub>L</sub> = 50 pF			
		Min	Typ	Max	Min	Max	Min	Max		
t <sub>PLH</sub> t <sub>PHL</sub>	Propagation Delay I <sub>n</sub> to Z <sub>n</sub>	3.0 2.5	4.5 4.2	6.0 5.5	3.0 2.5	8.0 8.0	3.0 2.5	7.0 6.5	ns	3-1 3-4
t <sub>PLH</sub> t <sub>PHL</sub>	Propagation Delay S to Z <sub>n</sub>	4.5 3.5	10.1 6.5	13 8.5	4.5 3.5	15.5 10.5	4.5 3.5	15 9.5	ns	3-1 3-10
t <sub>PZH</sub> t <sub>PZL</sub>	Output Enable Time	3.0 3.0	5.9 5.5	7.5 7.5	3.0 3.0	9.5 10	3.0 3.0	8.5 8.5	ns	3-1 3-12 3-13
t <sub>PHZ</sub> t <sub>PLZ</sub>	Output Disable Time	2.0 2.0	4.3 4.5	6.0 6.0	2.0 2.0	7.0 9.5	2.0 2.0	7.0 7.0		

# 54F/74F258

## Quad 2-Input Multiplexer

(With 3-State Outputs)

### Description

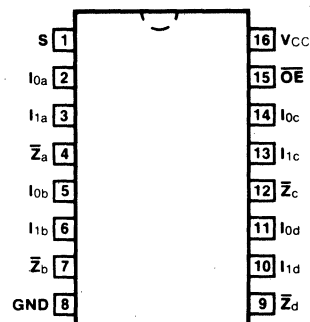
The 'F258 is a quad 2-input multiplexer with 3-state outputs. Four bits of data from two sources can be selected using a common data select input. The four outputs present the selected data in the complement (inverted) form. The outputs may be switched to a high-impedance state with a HIGH on the common Output Enable ( $\overline{OE}$ ) input, allowing the outputs to interface directly with bus oriented systems.

- Multiplexer Expansion by Tying Outputs Together
- Inverting 3-State outputs

**Ordering Code:** See Section 6

Pkgs	Commercial Grade	Military Grade	Pkg Type
	$V_{CC} = +5.0\text{ V} \pm 5\%$ , $T_A = 0^\circ\text{ C to } +70^\circ\text{ C}$	$V_{CC} = +5.0\text{ V} \pm 10\%$ , $T_A = -55^\circ\text{ C to } +125^\circ\text{ C}$	
Plastic DIP (P)	74F258PC		9B
Ceramic DIP (D)	74F258DC	54F258DM	6B
Flatpak (F)		54F258FM	4L

### Connection Diagram

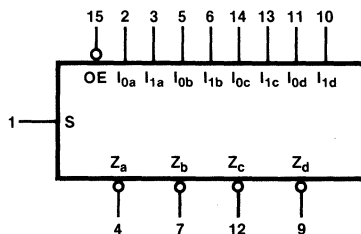


4

**Input Loading/Fan-Out:** See Section 3 for U.L. definitions

Pin Names	Description	54F/74F (U.L.) HIGH/LOW
S	Common Data Select Input	0.5/0.375
$\overline{OE}$	3-State Output Enable Input (Active LOW)	0.5/0.375
$I_{0a} - I_{0d}$	Data Inputs from Source 0	0.5/0.375
$I_{1a} - I_{1d}$	Data Inputs from Source 1	0.5/0.375
$Z_a - Z_d$	3-State Inverting Data Outputs	25/12.5

### Logic Symbol



$V_{CC}$  = Pin 16  
GND = Pin 8

**Functional Description**

The 'F258 is a quad 2-input multiplexer with 3-state outputs. It selects four bits of data from two sources under control of a common Select input (S). When the Select input is LOW, the I<sub>0x</sub> inputs are selected and when Select is HIGH, the I<sub>1x</sub> inputs are selected. The data on the selected inputs appears at the outputs in inverted form. The 'F258 is the logic implementation of a 4-pole, 2-position switch where the position of the switch is determined by the logic levels supplied to the Select input. The logic equations for the outputs are shown below:

$$\begin{aligned} \bar{Z}_a &= \overline{OE} \cdot (I_{1a} \cdot S + I_{0a} \cdot \bar{S}) \\ \bar{Z}_b &= \overline{OE} \cdot (I_{1b} \cdot S + I_{0b} \cdot \bar{S}) \\ \bar{Z}_c &= \overline{OE} \cdot (I_{1c} \cdot S + I_{0c} \cdot \bar{S}) \\ \bar{Z}_d &= \overline{OE} \cdot (I_{1d} \cdot S + I_{0d} \cdot \bar{S}) \end{aligned}$$

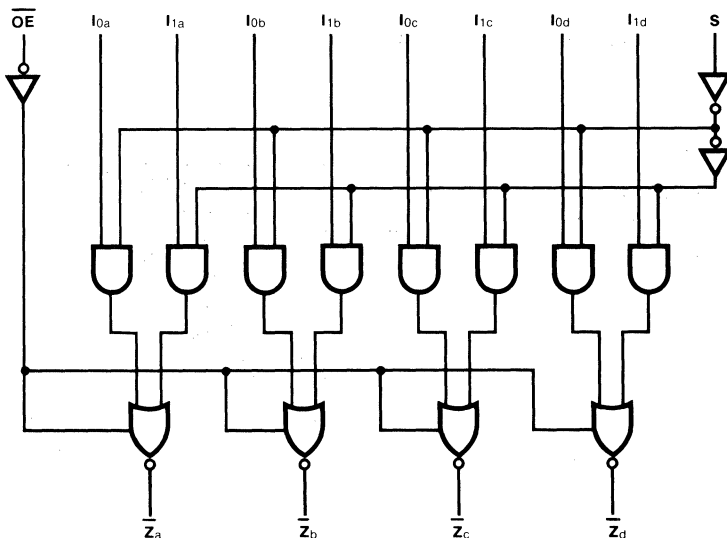
When the Output Enable input ( $\overline{OE}$ ) is HIGH, the outputs are forced to a high-impedance OFF state. If the outputs of the 3-state devices are tied together, all but one device must be in the high-impedance state to avoid high currents that would exceed the maximum ratings. Designers should ensure that Output Enable signals to 3-state devices whose outputs are tied together are designed so there is no overlap.

**Truth Table**

OUTPUT ENABLE	SELECT INPUT	DATA INPUTS		OUTPUTS
$\overline{OE}$	S	I <sub>0</sub>	I <sub>1</sub>	$\bar{Z}$
H	X	X	X	Z
L	H	X	L	H
L	H	X	H	L
L	L	L	X	H
L	L	H	X	L

H = HIGH Voltage Level  
 L = LOW Voltage Level  
 X = Immaterial  
 Z = High Impedance

**Logic Diagram**



**DC Characteristics over Operating Temperature Range** (unless otherwise specified)

Symbol	Parameter	54F/74F			Units	Conditions
		Min	Typ	Max		
I <sub>CC</sub> H	Power Supply Current		6.2	9.5	mA	V <sub>CC</sub> = Max; S, I <sub>1x</sub> = 4.5 V OE, I <sub>0x</sub> = Gnd
I <sub>CC</sub> L			15.1	23		V <sub>CC</sub> = Max; I <sub>1x</sub> = 4.5 V OE, I <sub>0x</sub> , S = Gnd
I <sub>CC</sub> Z			11.3	17		V <sub>CC</sub> = Max; S, I <sub>0x</sub> = Gnd OE, I <sub>1x</sub> = 4.5 V

**AC Characteristics:** See Section 3 for waveforms and load configurations

Symbol	Parameter	54F/74F			54F		74F		Units	Fig. No.
		T <sub>A</sub> = +25°C, V <sub>CC</sub> = +5.0 V C <sub>L</sub> = 50 pF			T <sub>A</sub> , V <sub>CC</sub> = Mil C <sub>L</sub> = 50 pF		T <sub>A</sub> , V <sub>CC</sub> = Com C <sub>L</sub> = 50 pF			
		Min	Typ	Max	Min	Max	Min	Max		
t <sub>PLH</sub> t <sub>PHL</sub>	Propagation Delay I <sub>n</sub> to Z <sub>n</sub>	2.5 2.0	4.0 3.5	5.3 4.7	2.0 1.5	7.5 6.0	2.5 2.0	6.0 5.5	ns	3-1 3-3
t <sub>PLH</sub> t <sub>PHL</sub>	Propagation Delay S to Z <sub>n</sub>	4.0 4.0	6.5 7.3	8.5 9.5	4.0 4.0	12 11.5	4.0 4.0	9.5 11	ns	3-1 3-10
t <sub>PZH</sub> t <sub>PZL</sub>	Output Enable Time	3.0 3.0	5.9 5.5	7.5 7.5	3.0 3.0	11 9.5	3.0 3.0	8.5 8.5	ns	3-1 3-12 3-13
t <sub>PHZ</sub> t <sub>PLZ</sub>	Output Disable Time	2.0 2.0	4.3 4.5	6.0 6.0	1.5 2.0	7.0 9.0	2.0 2.0	7.0 7.0		

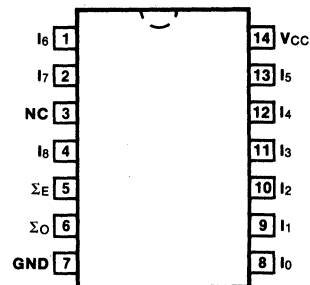
4



# 54F/74F280

## 9-Bit Parity Generator/Checker

### Connection Diagram



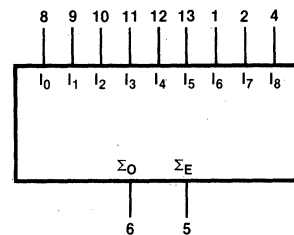
### Description

The 'F280 is a high-speed parity generator/checker that accepts nine bits of input data and detects whether an even or an odd number of these inputs is HIGH. If an even number of inputs is HIGH, the Sum Even output is HIGH. If an odd number is HIGH, the Sum Even output is LOW. The Sum Odd output is the complement of the Sum Even output.

**Ordering Code:** See Section 6

Pkgs	Commercial Grade	Military Grade	Pkg Type
	$V_{CC} = +5.0\text{ V} \pm 5\%$ , $T_A = 0^\circ\text{ C to } +70^\circ\text{ C}$	$V_{CC} = +5.0\text{ V} \pm 10\%$ , $T_A = -55^\circ\text{ C to } +125^\circ\text{ C}$	
Plastic DIP (P)	74F280PC		9A
Ceramic DIP (D)	74F280DC	54F280DM	6A
Flatpak (F)		54F280FM	3I

### Logic Symbol



$V_{CC}$  = Pin 14  
GND = Pin 7

**Input Loading/Fan-Out:** See Section 3 for U.L. definitions

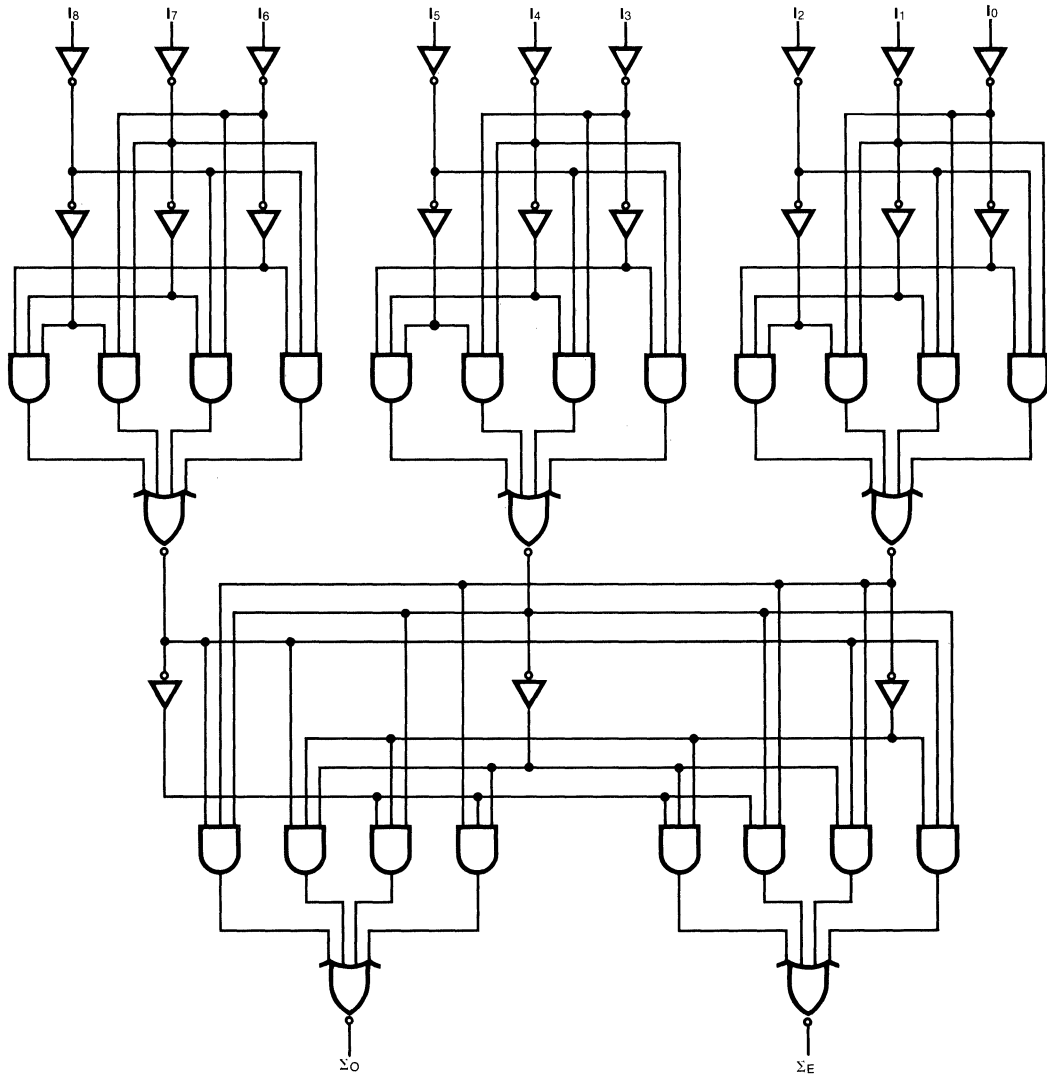
Pin Names	Description	54F/74F (U.L.) HIGH/LOW
$I_0 - I_8$	Data Inputs	0.5/0.375
$\Sigma O$	Odd Parity Output	25/12.5
$\Sigma E$	Even Parity Output	25/12.5

### Truth Table

NUMBER OF INPUTS $I_0 - I_8$ THAT ARE HIGH	OUTPUTS	
	$\Sigma$ EVEN	$\Sigma$ ODD
0, 2, 4, 6, 8	H	L
1, 3, 5, 7, 9	L	H

H = HIGH Voltage Level  
L = LOW Voltage Level

## Logic Diagram



**DC Characteristics over Operating Temperature Range** (unless otherwise specified)

Symbol	Parameter	54F/74F			Units	Conditions
		Min	Typ	Max		
I <sub>CC</sub>	Power Supply Current	23	34.5		mA	V <sub>CC</sub> = Max

**AC Characteristics:** See Section 3 for waveforms and load configurations

Symbol	Parameter	54F/74F			54F		74F		Units	Fig. No.
		T <sub>A</sub> = +25°C, V <sub>CC</sub> = +5.0 V C <sub>L</sub> = 50 pF			T <sub>A</sub> , V <sub>CC</sub> = Mil C <sub>L</sub> = 50 pF		T <sub>A</sub> , V <sub>CC</sub> = Com C <sub>L</sub> = 50 pF			
		Min	Typ	Max	Min	Max	Min	Max		
t <sub>PLH</sub> t <sub>PHL</sub>	Propagation Delay I <sub>n</sub> to ΣE	6.0	10	14					ns	3-1 3-10
t <sub>PLH</sub> t <sub>PHL</sub>	Propagation Delay I <sub>n</sub> to ΣO	6.0	10	14					ns	3-1 3-10

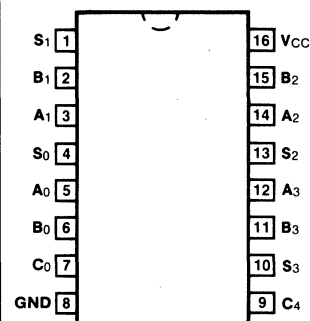
■ Test limits in screened columns are preliminary.

# 54F/74F283

## 4-Bit Binary Full Adder

(With Fast Carry)

### Connection Diagram



### Description

The 'F283 high-speed 4-bit binary full adder with internal carry lookahead accepts two 4-bit binary words ( $A_0 - A_3$ ,  $B_0 - B_3$ ) and a Carry input ( $C_0$ ). It generates the binary Sum outputs ( $S_0 - S_3$ ) and the Carry output ( $C_4$ ) from the most significant bit. The 'F283 will operate with either active-HIGH or active-LOW operands (positive or negative logic).

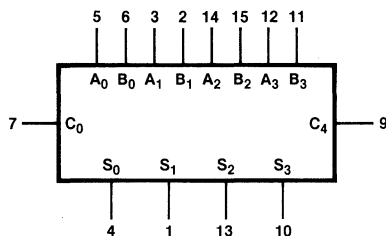
**Ordering Code:** See Section 6

Pkgs	Commercial Grade	Military Grade	Pkg Type
	$V_{CC} = +5.0 \text{ V} \pm 5\%$ , $T_A = 0^\circ \text{ C to } +70^\circ \text{ C}$	$V_{CC} = +5.0 \text{ V} \pm 10\%$ , $T_A = -55^\circ \text{ C to } +125^\circ \text{ C}$	
Plastic DIP (P)	74F283PC		9B
Ceramic DIP (D)	74F283DC	54F283DM	6B
Flatpak (F)		54F283FM	4L

**Input Loading/Fan-Out:** See Section 3 for U.L. definitions

Pin Names	Description	54F/74F (U.L.) HIGH/LOW
$A_0 - A_3$	A Operand Inputs	0.5/0.75
$B_0 - B_3$	B Operand Inputs	0.5/0.75
$C_0$	Carry Input	0.5/0.375
$S_0 - S_3$	Sum Outputs	25/12.5
$C_4$	Carry Output	25/12.5

### Logic Symbol



$V_{CC} = \text{Pin } 16$   
 $GND = \text{Pin } 8$

**Functional Description**

The 'F283 adds two 4-bit binary words (A plus B) plus the incoming carry  $C_0$ . The binary sum appears on the Sum ( $S_0-S_3$ ) and outgoing carry ( $C_4$ ) outputs. The binary weight of the various inputs and outputs is indicated by the subscript numbers, representing powers of two.

$$2^0 (A_0 + B_0 + C_0) + 2^1 (A_1 + B_1) + 2^2 (A_2 + B_2) + 2^3 (A_3 + B_3) = S_0 + 2S_1 + 4S_2 + 8S_3 + 16C_4$$

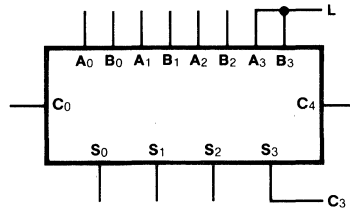
Where (+) = plus

Interchanging inputs of equal weight does not affect the operation. Thus  $C_0, A_0, B_0$  can be arbitrarily assigned to pins 5, 6 and 7. Due to the symmetry of the binary add function, the 'F283 can be used either with all inputs and outputs active HIGH (positive logic) or with all inputs and outputs active LOW (negative logic). See *Figure a*. Note that if  $C_0$  is not used it must be tied LOW for active-HIGH logic or tied HIGH for active-LOW logic.

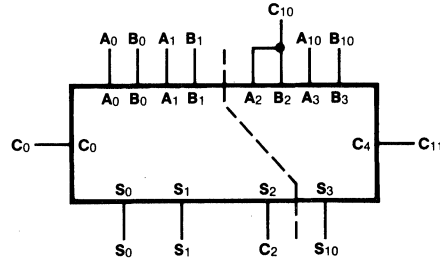
Due to pin limitations, the intermediate carries of the 'F283 are not brought out for use as inputs or outputs. However, other means can be used to effectively insert a carry into, or bring a carry out from, an intermediate stage. *Figure b* shows how to make a 3-bit adder. The third stage adder ( $A_2, B_2, S_2$ ) is used merely as a means of getting a carry ( $C_{10}$ ) signal into the fourth stage (via  $A_2$  and  $B_2$ ) and bringing out the carry from the second stage on  $S_2$ . Note that as long as  $A_2$  and  $B_2$  are the same, whether HIGH or LOW, they do not influence  $S_2$ . Similarly, when  $A_2$  and  $B_2$  are the same the carry into the third stage does not influence the carry out of the third stage. *Figure d* shows a method of implementing a 5-input encoder, where the inputs are equally weighted. The outputs

$S_0, S_1$  and  $S_2$  present a binary number equal to the number of inputs  $I_1 - I_5$  that are true. *Figure e* shows one method of implementing a 5-input majority gate. When three or more of the inputs  $I_1 - I_5$  are true, the output  $M_5$  is true.

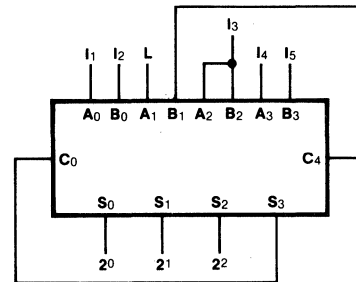
**Fig. b 3-Bit Adder**



**Fig. c 2-Bit and 1-Bit Adders**



**Fig. d 5-Input Encoder**



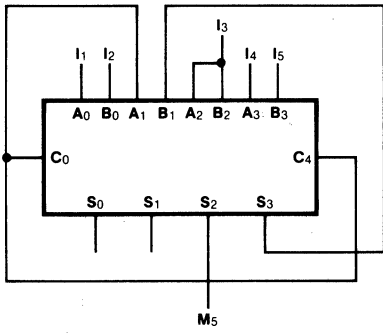
**Fig. a Active-HIGH versus Active-LOW Interpretation**

	$C_0$	$A_0$	$A_1$	$A_2$	$A_3$	$B_0$	$B_1$	$B_2$	$B_3$	$S_0$	$S_1$	$S_2$	$S_3$	$C_4$
Logic Levels	L	L	H	L	H	H	L	L	H	H	H	L	L	H
Active HIGH	0	0	1	0	1	1	0	0	1	1	1	0	0	1
Active LOW	1	1	0	1	0	0	1	1	0	0	0	1	1	0

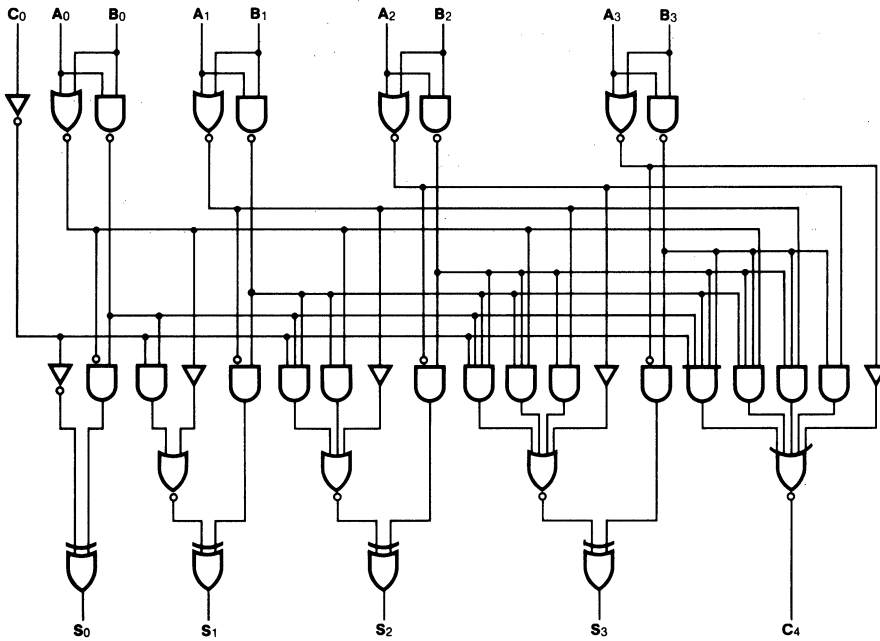
Active HIGH:  $0 + 10 + 9 = 3 + 16$

Active LOW:  $1 + 5 + 6 = 12 + 0$

Fig. e 5-Input Majority Gate



Logic Diagram



Please note that this diagram is provided only for the understanding of logic operations and should not be used to estimate propagation delays.

**DC Characteristics over Operating Temperature Range** (unless otherwise specified)

Symbol	Parameter	54F/74F			Units	Conditions
		Min	Typ	Max		
I <sub>CC</sub>	Power Supply Current		36	55	mA	V <sub>CC</sub> = Max Inputs = 4.5 V

**AC Characteristics:** See Section 3 for waveforms and load configurations

Symbol	Parameter	54F/74F			54F		74F		Units	Fig. No.
		T <sub>A</sub> = +25°C, V <sub>CC</sub> = +5.0 V C <sub>L</sub> = 50 pF			T <sub>A</sub> , V <sub>CC</sub> = Mil C <sub>L</sub> = 50 pF		T <sub>A</sub> , V <sub>CC</sub> = Com C <sub>L</sub> = 50 pF			
		Min	Typ	Max	Min	Max	Min	Max		
t <sub>PLH</sub> t <sub>PHL</sub>	Propagation Delay C <sub>0</sub> to S <sub>n</sub>	4.0 4.5	7.0 7.0	10 10	3.5 4.0	13.5 13.5	3.5 4.0	10.5 10.5	ns	3-1 3-10
t <sub>PLH</sub> t <sub>PHL</sub>	Propagation Delay A <sub>n</sub> or B <sub>n</sub> to S <sub>n</sub>	3.0 3.5	7.0 7.0	10 10	4.0 3.5	13.5 13.5	4.0 3.5	10.5 10.5	ns	3-1 3-10
t <sub>PLH</sub> t <sub>PHL</sub>	Propagation Delay C <sub>0</sub> to C <sub>4</sub>	3.0 3.5	5.7 5.4	6.5 6.5	3.5 3.0	10.5 10	3.5 3.0	8.5 8.0	ns	3-1 3-4
t <sub>PLH</sub> t <sub>PHL</sub>	Propagation Delay A <sub>n</sub> or B <sub>n</sub> to C <sub>4</sub>	3.5 3.5	5.7 5.3	6.5 6.5	3.5 3.0	10.5 10	3.5 3.0	8.5 8.0	ns	3-1 3-4

■ Test limits in screened columns are preliminary.

# 54F/74F289

## 64-Bit Random Access Memory (With Open-Collector Outputs)

### Description

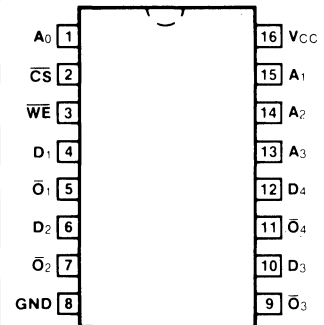
The 'F289 is a high-speed 64-bit RAM organized as a 16-word by 4-bit array. Address inputs are buffered to minimize loading, and addresses are fully decoded on-chip. Outputs are open-collector type and are in the OFF (HIGH) state whenever the Chip Select ( $\overline{CS}$ ) input is HIGH. The outputs are active only in the Read mode; output data is the complement of the stored data. This device is similar to the 'F319 but features inverting, rather than non-inverting, data outputs.

- Open-collector Outputs for Wired-AND Applications
- Buffered Inputs Minimize Loading
- Address Decoding On-chip
- Diode Clamped Inputs Minimize Ringing

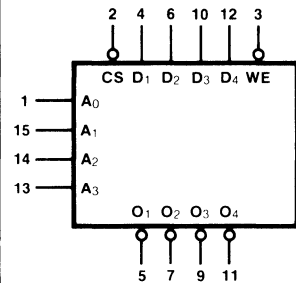
**Ordering Code:** See Section 6

Pkgs	Commercial Grade	Military Grade	Pkg Type
	$V_{CC} = +5.0\text{ V} \pm 5\%$ , $T_A = 0^\circ\text{ C to } +70^\circ\text{ C}$	$V_{CC} = +5.0\text{ V} \pm 10\%$ , $T_A = -55^\circ\text{ C to } +125^\circ\text{ C}$	
Plastic DIP (P)	74F289PC		9B
Ceramic DIP (D)	74F289DC	54F289DM	6B
Flatpak (F)		54F289FM	4L

### Connection Diagram



### Logic Symbol



$V_{CC} = \text{Pin } 16$   
 $GND = \text{Pin } 8$

**Input Loading/Fan-Out:** See Section 3 for U.L. definitions

Pin Names	Description	54F/74F (U.L.) HIGH/LOW
$A_0 - A_3$	Address Inputs	0.5/0.375
$\overline{CS}$	Chip Select Input (Active LOW)	0.5/0.75
$\overline{WE}$	Write Enable Input (Active LOW)	0.5/0.75
$D_1 - D_4$	Data Inputs	0.5/0.375
$\overline{O}_1 - \overline{O}_4$	Inverted Data Outputs	OC*/12.5

\*OC - Open Collector



## Function Table

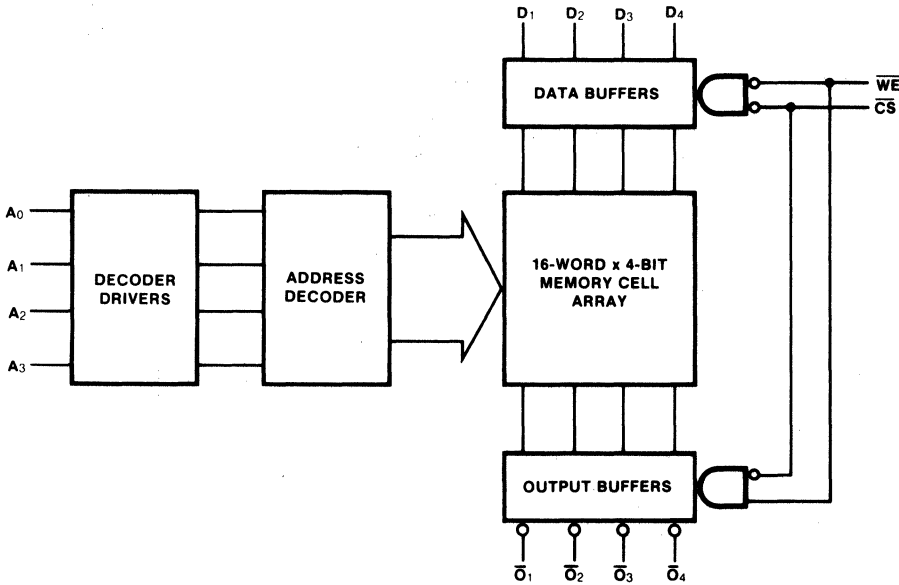
INPUTS		OPERATION	CONDITION OF OUTPUTS
$\overline{CS}$	$\overline{WE}$		
L	L	Write	Off (HIGH)
L	H	Read	Complement of Stored Data
H	X	Inhibit	Off (HIGH)

H = HIGH Voltage Level

L = LOW Voltage Level

X = Immaterial

## Logic Diagram



**DC Characteristics over Operating Temperature Range** (unless otherwise specified)

Symbol	Parameter	54F/74F			Units	Conditions
		Min	Typ	Max		
I <sub>CC</sub>	Power Supply Current		37	55	mA	V <sub>CC</sub> = Max; $\overline{WE}$ , $\overline{CS}$ = Gnd

**AC Characteristics:** See Section 3 for waveforms and load configurations

Symbol	Parameter	54F/74F			54F		74F		Units	Fig. No.
		T <sub>A</sub> = +25°C, V <sub>CC</sub> = +5.0 V C <sub>L</sub> = 50 pF			T <sub>A</sub> , V <sub>CC</sub> = Mil C <sub>L</sub> = 50 pF		T <sub>A</sub> , V <sub>CC</sub> = Com C <sub>L</sub> = 50 pF			
		Min	Typ	Max	Min	Max	Min	Max		
t <sub>PLH</sub> t <sub>PHL</sub>	Access Time, HIGH or LOW A <sub>n</sub> to $\overline{O}_n$	11	18	25				ns	3-1 3-10	
t <sub>PHL</sub>	Access Time $\overline{CS}$ to $\overline{O}_n$	4.5	8.0	11				ns	3-1 3-4	
t <sub>PLH</sub>	Disable Time $\overline{CS}$ to O <sub>n</sub>	6.0	10.2	14						
t <sub>PHL</sub>	Write Recovery Time WE to $\overline{O}_n$	8.0	13.5	19				ns	3-1 3-3	
t <sub>PLH</sub>	Disable Time WE to $\overline{O}_n$	8.0	13.5	19						

**AC Operating Requirements:** See Section 3 for waveforms

Symbol	Parameter	54F/74F			54F		74F		Units	Fig. No.
		T <sub>A</sub> = +25°C, V <sub>CC</sub> = +5.0 V			T <sub>A</sub> , V <sub>CC</sub> = Mil		T <sub>A</sub> , V <sub>CC</sub> = Com			
		Min	Typ	Max	Min	Max	Min	Max		
t <sub>s</sub> (H) t <sub>s</sub> (L)	Setup Time, HIGH or LOW A <sub>n</sub> to $\overline{WE}$	0						ns	3-16	
t <sub>h</sub> (H) t <sub>h</sub> (L)	Hold Time, HIGH or LOW A <sub>n</sub> to $\overline{WE}$	0								
t <sub>s</sub> (H) t <sub>s</sub> (L)	Setup Time, HIGH or LOW D <sub>n</sub> to $\overline{WE}$	10						ns	3-14	
t <sub>h</sub> (H) t <sub>h</sub> (L)	Hold Time, HIGH or LOW D <sub>n</sub> to $\overline{WE}$	0								
t <sub>s</sub> (L)	Setup Time LOW $\overline{CS}$ to $\overline{WE}$	6.0						ns	3-14	
t <sub>h</sub> (L)	Hold Time LOW $\overline{CS}$ to $\overline{WE}$	0								
t <sub>w</sub> (L)	$\overline{WE}$ Pulse Width LOW	6.0						ns	3-16	

■ Test limits in screened columns are preliminary.

## 54F/74F299

## 8-Input Universal Shift/Storage Register

(With Common Parallel I/O Pins)

## Connection Diagram

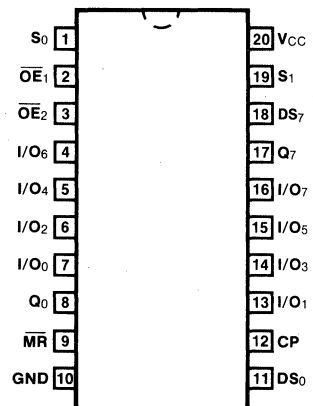
## Description

The 'F299 is an 8-bit universal shift/storage register with 3-state outputs. Four modes of operation are possible: hold (store), shift left, shift right and load data. The parallel load inputs and flip-flop outputs are multiplexed to reduce the total number of package pins. Additional outputs are provided for flip-flops  $Q_0$  and  $Q_7$  to allow easy serial cascading. A separate active-LOW Master Reset is used to reset the register.

- Common Parallel I/O for Reduced Pin Count
- Additional Serial Inputs and Outputs for Expansion
- Four Operating Modes: Shift Left, Shift Right, Load and Store
- 3-State Outputs for Bus Oriented Applications

Ordering Code: See Section 6

Pkgs	Commercial Grade	Military Grade	Pkg Type
	$V_{CC} = +5.0\text{ V} \pm 5\%$ , $T_A = 0^\circ\text{C to } +70^\circ\text{C}$	$V_{CC} = +5.0\text{ V} \pm 10\%$ , $T_A = -55^\circ\text{C to } +125^\circ\text{C}$	
Plastic DIP (P)	74F299PC		9Z
Ceramic DIP (D)	74F299DC	54F299DM	4E
Flatpak (F)		54F299FM	4D



Input Loading/Fan-Out: See Section 3 for U.L. definitions

Pin Names	Description	54F/74F (U.L.) HIGH/LOW
CP	Clock Pulse Input (Active Rising Edge)	0.5/0.375
DS <sub>0</sub>	Serial Data Input for Right Shift	0.5/0.375
DS <sub>7</sub>	Serial Data Input for Left Shift	0.5/0.375
S <sub>0</sub> , S <sub>1</sub>	Mode Select Inputs	0.5/0.75
$\overline{MR}$	Asynchronous Master Reset Input (Active LOW)	0.5/0.375
$\overline{OE}_1$ , $\overline{OE}_2$	3-State Output Enable Inputs (Active LOW)	0.5/0.375
I/O <sub>0</sub> - I/O <sub>7</sub>	Parallel Data Inputs or 3-State Parallel Outputs	0.5/0.375 25/12.5
Q <sub>0</sub> , Q <sub>7</sub>	Serial Outputs	25/12.5

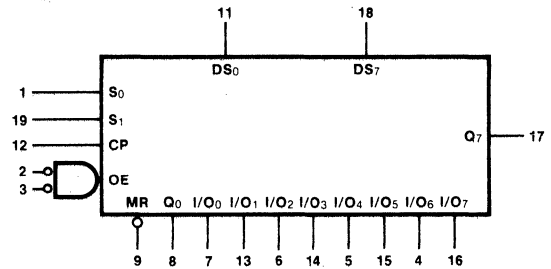
## Functional Description

The 'F299 contains eight edge-triggered D-type flip-flops and the interstage logic necessary to perform synchronous shift left, shift right, parallel load and hold operations. The type of operation is determined by  $S_0$  and  $S_1$ , as shown in the Mode Select Table. All flip-flop outputs are brought out through 3-state buffers to separate I/O pins that also serve as data inputs in the parallel load mode.  $Q_0$  and  $Q_7$  are also brought out on other pins for expansion in serial shifting of longer words.

A LOW signal on  $\overline{MR}$  overrides the Select and CP inputs and resets the flip-flops. All other state changes are initiated by the rising edge of the clock. Inputs can change when the clock is in either state provided only that the recommended setup and hold times, relative to the rising edge of CP, are observed.

A HIGH signal on either  $\overline{OE}_1$  or  $\overline{OE}_2$  disables the 3-state buffers and puts the I/O pins in the high impedance state. In this condition the shift, hold, load and reset operations can still occur. The 3-state buffers are also disabled by HIGH signals on both  $S_0$  and  $S_1$  in preparation for a parallel load operation.

## Logic Symbol



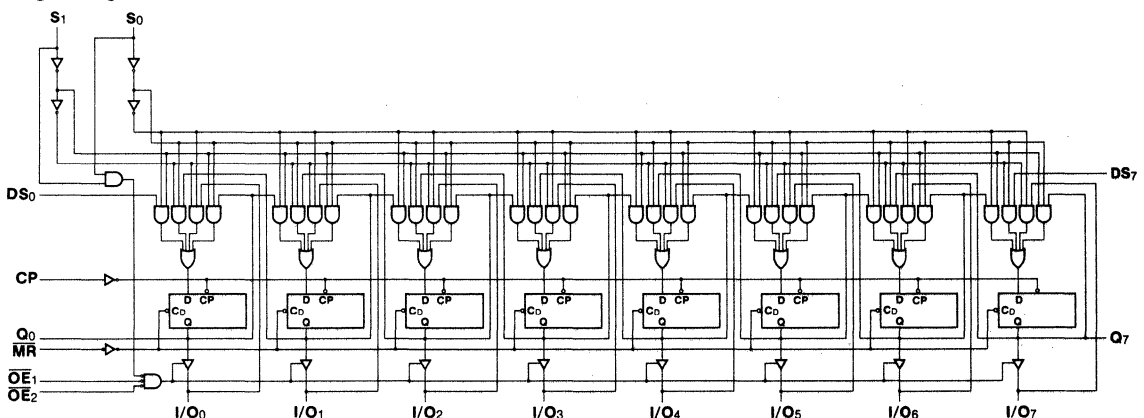
$V_{CC}$  = Pin 20  
GND = Pin 10

## Mode Select Table

INPUTS				RESPONSE
$\overline{MR}$	$S_1$	$S_0$	CP	
L	X	X	X	Asynchronous Reset; $Q_0 - Q_7 = \text{LOW}$
H	H	H	$\square$	Parallel Load; $I/O_n - Q_n$
H	L	H	$\square$	Shift Right; $DS_0 \rightarrow Q_0, Q_0 \rightarrow Q_1, \text{etc.}$
H	H	L	$\square$	Shift Left; $DS_7 \rightarrow Q_7, Q_7 \rightarrow Q_6, \text{etc.}$
H	L	L	X	Hold

H = HIGH Voltage Level  
L = LOW Voltage Level  
X = Immaterial

## Logic Diagram



**DC Characteristics over Operating Temperature Range** (unless otherwise specified)

Symbol	Parameter	54F/74F			Units	Conditions
		Min	Typ	Max		
I <sub>CC</sub>	Power Supply Current		68	95	mA	V <sub>CC</sub> = Max, $\overline{OE}$ = 4.5 V CP = HIGH
I <sub>IH</sub>	Input HIGH Current Breakdown Test, I/O <sub>0</sub> -I/O <sub>7</sub>			100	μA	V <sub>CC</sub> = Max, V <sub>IN</sub> = 5.5 V
I <sub>IH</sub> + I <sub>OZH</sub>	3-State Output OFF Current HIGH, I/O <sub>0</sub> -I/O <sub>7</sub>			70	μA	V <sub>CC</sub> = Max, V <sub>OUT</sub> = 2.4 V
I <sub>IL</sub> + I <sub>OZL</sub>	3-State Output OFF Current LOW, I/O <sub>0</sub> -I/O <sub>7</sub>			-650	μA	V <sub>CC</sub> = Max, V <sub>OUT</sub> = 0.5 V

**AC Characteristics:** See Section 3 for waveforms and load configurations

Symbol	Parameter	54F/74F			54F		74F		Units	Fig. No.
		T <sub>A</sub> = +25°C., V <sub>CC</sub> = +5.0 V C <sub>L</sub> = 50 pF			T <sub>A</sub> , V <sub>CC</sub> = Mil C <sub>L</sub> = 50 pF		T <sub>A</sub> , V <sub>CC</sub> = Com C <sub>L</sub> = 50 pF			
		Min	Typ	Max	Min	Max	Min	Max		
f <sub>max</sub>	Maximum Input Frequency	70							MHz	3-1, 3-7
t <sub>PLH</sub> t <sub>PHL</sub>	Propagation Delay CP to Q <sub>0</sub> or Q <sub>7</sub>	5.5 5.5	10 10	14 14					ns	3-1 3-7
t <sub>PLH</sub> t <sub>PHL</sub>	Propagation Delay CP to I/O <sub>n</sub>	5.5 5.5	10 10	14 14						
t <sub>PHL</sub>	Propagation Delay MR to Q <sub>0</sub> or Q <sub>7</sub>	6.5	12	16					ns	3-1 3-11
t <sub>PHL</sub>	Propagation Delay MR to I/O <sub>n</sub>	6.5	12	16						
t <sub>PZH</sub> t <sub>PZL</sub>	Output Enable Time	6.0 6.0	10 10	14 14					ns	3-1 3-12 3-13
t <sub>PHZ</sub> t <sub>PLZ</sub>	Output Disable Time	4.0 4.0	7.0 7.0	10 10						

■ Test limits in screened columns are preliminary.

**AC Operating Requirements:** See Section 3 for waveforms

Symbol	Parameter	54F/74F			54F		74F		Units	Fig. No.
		T <sub>A</sub> = +25°C, V <sub>CC</sub> = +5.0 V			T <sub>A</sub> , V <sub>CC</sub> = Mil		T <sub>A</sub> , V <sub>CC</sub> = Com			
		Min	Typ	Max	Min	Max	Min	Max		
t <sub>s</sub> (H) t <sub>s</sub> (L)	Setup Time, HIGH or LOW S <sub>0</sub> or S <sub>1</sub> to CP	12						ns	3-5	
t <sub>h</sub> (H) t <sub>h</sub> (L)	Hold Time, HIGH or LOW S <sub>0</sub> or S <sub>1</sub> to CP	0								
t <sub>s</sub> (H) t <sub>s</sub> (L)	Setup Time, HIGH or LOW I/O <sub>n</sub> , DS <sub>0</sub> , DS <sub>7</sub> to CP	5.0						ns	3-5	
t <sub>h</sub> (H) t <sub>h</sub> (L)	Hold Time, HIGH or LOW I/O <sub>n</sub> , DS <sub>0</sub> , DS <sub>7</sub> to CP	0								
t <sub>w</sub> (H) t <sub>w</sub> (L)	CP Pulse Width, HIGH or LOW	7.0						ns	3-7	
t <sub>w</sub> (L)	$\overline{MR}$ Pulse Width LOW	7.0						ns	3-11	
t <sub>rec</sub>	Recovery Time MR to CP	5.0						ns	3-11	

■ Test limits in screened columns are preliminary.

## 54F/74F319

64-Bit Random Access Memory  
(With Open-Collector Outputs)

### Description

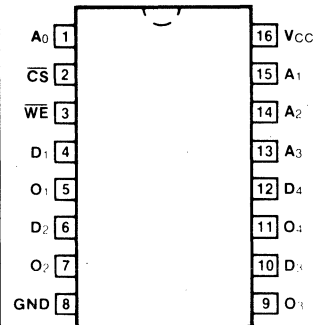
The 'F319 is a high-speed 64-bit RAM organized as a 16-word by 4-bit array. Address inputs are buffered to minimize loading, and addresses are fully decoded on-chip. Outputs are open-collector type and are in the OFF (HIGH) state whenever the Chip Select ( $\overline{CS}$ ) input is HIGH. The outputs are active only in the Read mode. This device is similar to the 'F289 but features non-inverting, rather than inverting, data outputs.

- Open-collector Outputs for Wired-AND Applications
- Buffered Inputs Minimize Loading
- Address Decoding On-chip
- Diode Clamped Inputs Minimize Ringing

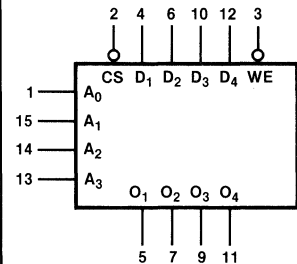
Ordering Code: See Section 6

Pkgs	Commercial Grade	Military Grade	Pkg Type
	$V_{CC} = +5.0 \text{ V} \pm 5\%$ , $T_A = 0^\circ \text{C to } +70^\circ \text{C}$	$V_{CC} = +5.0 \text{ V} \pm 10\%$ , $T_A = -55^\circ \text{C to } +125^\circ \text{C}$	
Plastic DIP (P)	74F319PC		9B
Ceramic DIP (D)	74F319DC	54F319DM	6B
Flatpak (F)		54F319FM	4L

### Connection Diagram



### Logic Symbol



$V_{CC}$  = Pin 16  
GND = Pin 8

Input Loading/Fan-Out: See Section 3 for U.L. definitions

Pin Names	Description	54F/74F (U.L.) HIGH/LOW
$A_0 - A_3$	Address Inputs	0.5/0.375
$\overline{CS}$	Chip Select Input (Active LOW)	0.5/0.75
$\overline{WE}$	Write Enable Input (Active LOW)	0.5/0.75
$D_1 - D_4$	Data Inputs	0.5/0.375
$O_1 - O_4$	Data Outputs	OC*/12.5

\*OC - Open Collector

Function Table

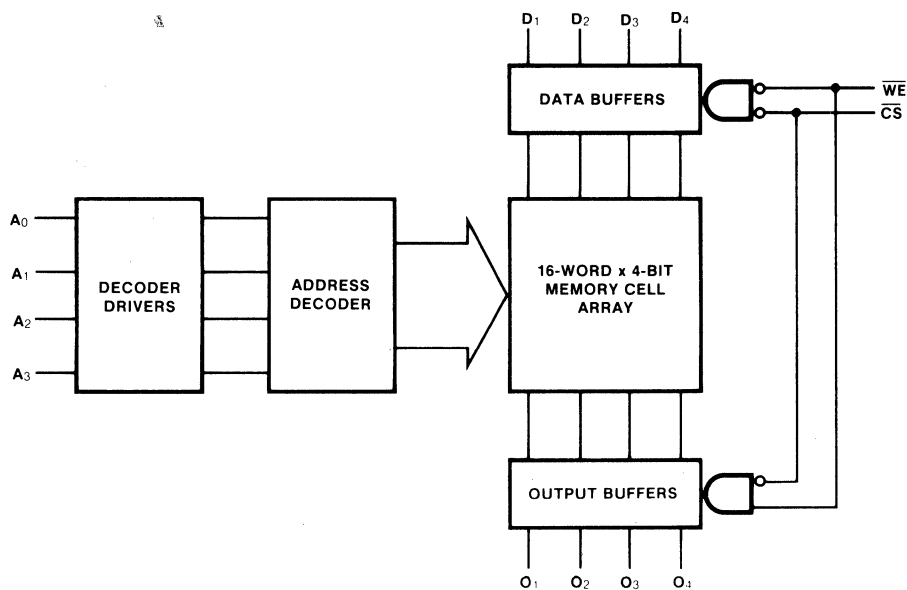
INPUTS		OPERATION	CONDITION OF OUTPUTS
$\overline{CS}$	$\overline{WE}$		
L	L	Write	Off (HIGH)
L	H	Read	Complement of Stored Data
H	X	Inhibit	Off (HIGH)

H = HIGH Voltage Level

L = LOW Voltage Level

X = Immaterial

Logic Diagram





## DC Characteristics over Operating Temperature Range (unless otherwise specified)

Symbol	Parameter	54F/74F			Units	Conditions
		Min	Typ	Max		
I <sub>CC</sub>	Power Supply Current		37	55	mA	V <sub>CC</sub> = Max; $\overline{WE}$ , $\overline{CS}$ = Gnd

## AC Characteristics: See Section 3 for waveforms and load configurations

Symbol	Parameter	54F/74F			54F		74F		Units	Fig. No.
		T <sub>A</sub> = +25°C, V <sub>CC</sub> = +5.0 V C <sub>L</sub> = 50 pF			T <sub>A</sub> , V <sub>CC</sub> = Mil C <sub>L</sub> = 50 pF		T <sub>A</sub> , V <sub>CC</sub> = Com C <sub>L</sub> = 50 pF			
		Min	Typ	Max	Min	Max	Min	Max		
t <sub>PLH</sub> t <sub>PHL</sub>	Access Time, HIGH or LOW A <sub>n</sub> to O <sub>n</sub>	11 8.0	18 14	25 20				ns	3-1 3-10	
t <sub>PHL</sub>	Access Time $\overline{CS}$ to O <sub>n</sub>	4.5	8.0	11				ns	3-1 3-4	
t <sub>PLH</sub>	Disable Time $\overline{CS}$ to O <sub>n</sub>	6.0	10.2	14						
t <sub>PHL</sub>	Write Recovery Time $\overline{WE}$ to O <sub>n</sub>	8.0	13.5	19				ns	3-1 3-3	
t <sub>PLH</sub>	Disable Time $\overline{WE}$ to O <sub>n</sub>	8.0	13.5	19						

## AC Operating Requirements: See Section 3 for waveforms

Symbol	Parameter	54F/74F			54F		74F		Units	Fig. No.
		T <sub>A</sub> = +25°C, V <sub>CC</sub> = +5.0 V			T <sub>A</sub> , V <sub>CC</sub> = Mil		T <sub>A</sub> , V <sub>CC</sub> = Com			
		Min	Typ	Max	Min	Max	Min	Max		
t <sub>s</sub> (H) t <sub>s</sub> (L)	Setup Time, HIGH or LOW A <sub>n</sub> to $\overline{WE}$	0 0						ns	3-16	
t <sub>h</sub> (H) t <sub>h</sub> (L)	Hold Time, HIGH or LOW A <sub>n</sub> to $\overline{WE}$	0 0								
t <sub>s</sub> (H) t <sub>s</sub> (L)	Setup Time, HIGH or LOW D <sub>n</sub> to $\overline{WE}$	10 10						ns	3-14	
t <sub>h</sub> (H) t <sub>h</sub> (L)	Hold Time, HIGH or LOW D <sub>n</sub> to $\overline{WE}$	0 0								
t <sub>s</sub> (L)	Setup Time LOW $\overline{CS}$ to $\overline{WE}$	6.0						ns	3-14	
t <sub>h</sub> (L)	Hold Time LOW $\overline{CS}$ to $\overline{WE}$	0								
t <sub>w</sub> (L)	$\overline{WE}$ Pulse Width LOW	6.0						ns	3-16	

■ Test limits in screened columns are preliminary.

# 54F/74F322

## 8-Bit Serial/Parallel Register

(With Sign Extend)

### Connection Diagram

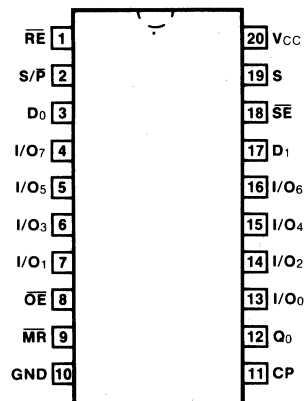
#### Description

The 'F322 is an 8-bit shift register with provision for either serial or parallel loading and with 3-state parallel outputs plus a bi-state serial output. Parallel data inputs and parallel outputs are multiplexed to minimize pin count. State changes are initiated by the rising edge of the clock. Four synchronous modes of operation are possible: hold (store), shift right with serial entry, shift right with sign extend and parallel load. An asynchronous Master Reset ( $\overline{MR}$ ) input overrides clocked operation and clears the register.

- Multiplexed Parallel I/O Ports
- Separate Serial Input and Output
- Sign Extend Function
- 3-State Outputs for Bus Applications

**Ordering Code:** See Section 6

Pkgs	Commercial Grade	Military Grade	Pkg Type
	$V_{CC} = +5.0\text{ V} \pm 5\%$ , $T_A = 0^\circ\text{ C to } +70^\circ\text{ C}$	$V_{CC} = +5.0\text{ V} \pm 10\%$ , $T_A = -55^\circ\text{ C to } +125^\circ\text{ C}$	
Plastic DIP (P)	74F322PC		9Z
Ceramic DIP (D)	74F322DC	54F322DM	4E
Flatpak (F)		54F322FM	4D



4

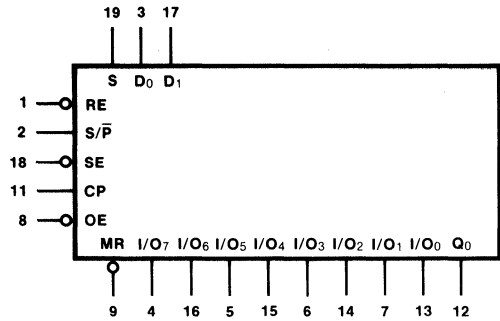
**Input Loading/Fan-Out:** See Section 3 for U.L. definitions

Pin Names	Description	54F/74F (U.L.) HIGH/LOW
$\overline{RE}$	Register Enable Input (Active LOW)	0.5/0.375
S/P	Serial (HIGH) or Parallel (LOW) Mode Control Input	0.5/0.375
$\overline{SE}$	Sign Extend Input (Active LOW)	0.5/1.125
S	Serial Data Select Input	0.5/0.75
D <sub>0</sub> , D <sub>1</sub>	Serial Data Inputs	0.5/0.375
CP	Clock Pulse Input (Active Rising Edge)	0.5/0.375
$\overline{MR}$	Asynchronous Master Reset Input (Active LOW)	0.5/0.375
OE	3-State Output Enable Input (Active LOW)	0.5/0.375
Q <sub>0</sub>	Bi-state Serial Output	25/12.5
I/O <sub>0</sub> - I/O <sub>7</sub>	Multiplexed Parallel Data Inputs or 3-State Parallel Data Outputs	0.5/0.375 25/12.5

## Functional Description

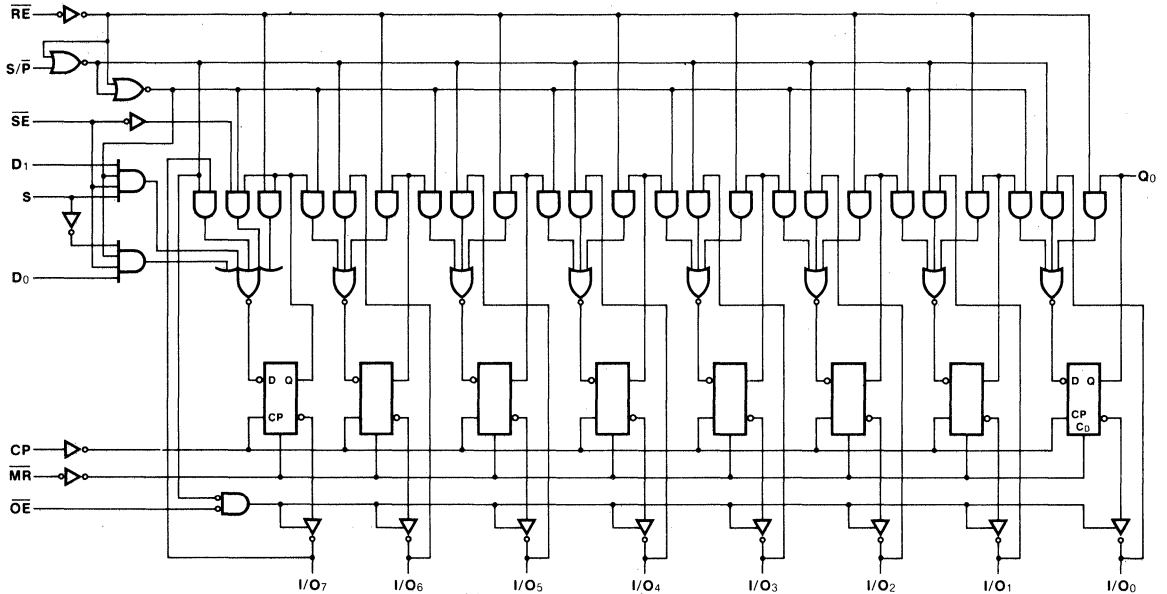
The 'F322 contains eight D-type edge triggered flip-flops and the interstage gating required to perform right shift and the intrastage gating necessary for hold and synchronous parallel load operations. A LOW signal on  $\overline{RE}$  enables shifting or parallel loading, while a HIGH signal enables the hold mode. A HIGH signal on  $S/\overline{P}$  enables shift right, while a LOW signal disables the 3-state output buffers and enables parallel loading. In the shift right mode a HIGH signal on  $\overline{SE}$  enables serial entry from either  $D_0$  or  $D_1$ , as determined by the S input. A LOW signal on  $\overline{SE}$  enables shift right but  $Q_7$  reloads its contents, thus performing the sign extend function required for the 'LS384 Twos Complement Multiplier. A HIGH signal on  $\overline{OE}$  disables the 3-state output buffers, regardless of the other control inputs. In this condition the shifting and loading operations can still be performed.

## Logic Symbol



$V_{CC}$  = Pin 20  
GND = Pin 10

## Logic Diagram



Mode Select Table

MODE	INPUTS							OUTPUTS								Q <sub>0</sub>
	$\overline{\text{MR}}$	$\overline{\text{RE}}$	$\text{S}/\overline{\text{P}}$	$\overline{\text{SE}}$	S	$\overline{\text{OE}}^*$	CP	I/O <sub>7</sub>	I/O <sub>6</sub>	I/O <sub>5</sub>	I/O <sub>4</sub>	I/O <sub>3</sub>	I/O <sub>2</sub>	I/O <sub>1</sub>	I/O <sub>0</sub>	
Clear	L	X	X	X	X	L	X	L	L	L	L	L	L	L	L	
	L	X	X	X	X	H	X	Z	Z	Z	Z	Z	Z	Z	Z	
Parallel Load	H	L	L	X	X	X	┘	I <sub>7</sub>	I <sub>6</sub>	I <sub>5</sub>	I <sub>4</sub>	I <sub>3</sub>	I <sub>2</sub>	I <sub>1</sub>	I <sub>0</sub>	
Shift Right	H	L	H	H	L	L	┘	D <sub>0</sub>	O <sub>7</sub>	O <sub>6</sub>	O <sub>5</sub>	O <sub>4</sub>	O <sub>3</sub>	O <sub>2</sub>	O <sub>1</sub>	
	H	L	H	H	H	L	┘	D <sub>1</sub>	O <sub>7</sub>	O <sub>6</sub>	O <sub>5</sub>	O <sub>4</sub>	O <sub>3</sub>	O <sub>2</sub>	O <sub>1</sub>	
Sign Extend	H	L	H	L	X	L	┘	O <sub>7</sub>	O <sub>7</sub>	O <sub>6</sub>	O <sub>5</sub>	O <sub>4</sub>	O <sub>3</sub>	O <sub>2</sub>	O <sub>1</sub>	
Hold	H	H	X	X	X	L	┘	NC	NC	NC	NC	NC	NC	NC	NC	

\*When the  $\overline{\text{OE}}$  input is HIGH, all I/O<sub>n</sub> terminals are at the high-impedance state; sequential operation or clearing of the register is not affected

1. I<sub>7</sub> - I<sub>0</sub> = The level of the steady-state input at the respective I/O terminal is loaded into the flip-flop while the flip-flop outputs (except Q<sub>0</sub>) are isolated from the I/O terminal.
  2. D<sub>0</sub>, D<sub>1</sub> = The level of the steady-state inputs to the serial multiplexer input.
  3. O<sub>7</sub> - O<sub>0</sub> = The level of the respective Q<sub>n</sub> flip-flop prior to the last Clock LOW-to-HIGH transition.
- NC = No change Z = High-Impedance Output State H = HIGH Voltage Level L = LOW Voltage Level

4

## DC Characteristics over Operating Temperature Range (unless otherwise specified)

Symbol	Parameter	54F/74F			Units	Conditions
		Min	Typ	Max		
I <sub>CC</sub>	Power Supply Current		60	84	mA	V <sub>CC</sub> = Max, CP = HIGH Output Disabled
I <sub>IH</sub>	Input HIGH Current Breakdown Test, I/O <sub>0</sub> - I/O <sub>7</sub>			100	μA	V <sub>CC</sub> = Max, V <sub>IN</sub> = 5.5 V
I <sub>IH</sub> + I <sub>OZH</sub>	3-State Output OFF Current HIGH, I/O <sub>0</sub> - I/O <sub>7</sub>			70	μA	V <sub>CC</sub> = Max, V <sub>OUT</sub> = 2.4 V
I <sub>IL</sub> + I <sub>OZL</sub>	3-State Output OFF Current LOW, I/O <sub>0</sub> - I/O <sub>7</sub>			-650	μA	V <sub>CC</sub> = Max, V <sub>OUT</sub> = 0.5 V

## AC Characteristics: See Section 3 for waveforms and load configurations

Symbol	Parameter	54F/74F			54F		74F		Units	Fig. No.
		T <sub>A</sub> = +25°C, V <sub>CC</sub> = +5.0 V C <sub>L</sub> = 50 pF			T <sub>A</sub> , V <sub>CC</sub> = Mil C <sub>L</sub> = 50 pF		T <sub>A</sub> , V <sub>CC</sub> = Com C <sub>L</sub> = 50 pF			
		Min	Typ	Max	Min	Max	Min	Max		
f <sub>max</sub>	Maximum Clock Frequency	70						MHz	3-1, 3-7	
t <sub>PLH</sub> t <sub>PHL</sub>	Propagation Delay CP to I/O <sub>n</sub>	5.5	10	14				ns	3-1 3-7	
t <sub>PLH</sub> t <sub>PHL</sub>	Propagation Delay CP to Q <sub>0</sub>	5.5	10	14						
t <sub>PHL</sub>	Propagation Delay $\overline{\text{MR}}$ to I/O <sub>n</sub>	6.5	12	16				ns	3-1 3-11	

■ Test limits in screened columns are preliminary.

**AC Characteristics** (cont'd): See Section 3 for waveforms and load configurations

Symbol	Parameter	54F/74F			54F		74F		Units	Fig. No.
		T <sub>A</sub> = +25°C, V <sub>CC</sub> = +5.0 V C <sub>L</sub> = 50 pF			T <sub>A</sub> , V <sub>CC</sub> = Mil C <sub>L</sub> = 50 pF		T <sub>A</sub> , V <sub>CC</sub> = Com C <sub>L</sub> = 50 pF			
		Min	Typ	Max	Min	Max	Min	Max		
t <sub>PHL</sub>	Propagation Delay MR to Q <sub>0</sub>	6.5	12	16				ns	3-1 3-11	
t <sub>PZH</sub> t <sub>PZL</sub>	Output Enable Time OE to I/O <sub>n</sub>	6.0	10	14				ns	3-1 3-12 3-13	
t <sub>PHZ</sub> t <sub>PLZ</sub>	Output Disable Time OE to I/O <sub>n</sub>	4.0	7.0	10						
t <sub>PZH</sub> t <sub>PZL</sub>	Output Enable Time S/P to I/O <sub>n</sub>	6.0	10	14				ns	3-1 3-12 3-13	
t <sub>PHZ</sub> t <sub>PLZ</sub>	Output Disable Time S/P to I/O <sub>n</sub>	4.0	7.0	10						

**AC Operating Requirements:** See Section 3 for waveforms

Symbol	Parameter	54F/74F			54F		74F		Units	Fig. No.
		T <sub>A</sub> = +25°C, V <sub>CC</sub> = +5.0 V			T <sub>A</sub> , V <sub>CC</sub> = Mil		T <sub>A</sub> , V <sub>CC</sub> = Com			
		Min	Typ	Max	Min	Max	Min	Max		
t <sub>s</sub> (H) t <sub>s</sub> (L)	Setup Time, HIGH or LOW RE to CP	12						ns	3-5	
t <sub>h</sub> (H) t <sub>h</sub> (L)	Hold Time, HIGH or LOW RE to CP	0								
t <sub>s</sub> (H) t <sub>s</sub> (L)	Setup Time, HIGH or LOW D <sub>0</sub> , D <sub>1</sub> or I/O <sub>n</sub> to CP	5.0						ns	3-5	
t <sub>h</sub> (H) t <sub>h</sub> (L)	Hold Time, HIGH or LOW D <sub>0</sub> , D <sub>1</sub> or I/O <sub>n</sub> to CP	0								
t <sub>s</sub> (H) t <sub>s</sub> (L)	Setup Time, HIGH or LOW SE to CP	12						ns	3-5	
t <sub>h</sub> (H) t <sub>h</sub> (L)	Hold Time, HIGH or LOW SE to CP	0								
t <sub>s</sub> (H) t <sub>s</sub> (L)	Setup Time, HIGH or LOW S/P to CP	12						ns	3-5	
t <sub>s</sub> (H) t <sub>s</sub> (L)	Setup Time, HIGH or LOW S to CP	12								
t <sub>h</sub> (H) t <sub>h</sub> (L)	Hold Time, HIGH or LOW S or S/P to CP	0								
t <sub>w</sub> (H)	CP Pulse Width HIGH	7.0						ns	3-7	
t <sub>w</sub> (L)	MR Pulse Width LOW	7.0						ns	3-11	
t <sub>rec</sub>	Recovery Time MR to CP	5.0						ns	3-11	

■ Test limits in screened columns are preliminary.

# 54F/74F323

8-Bit Universal Shift/Storage Register  
(With Synchronous Reset and Common I/O Pins)

## Description

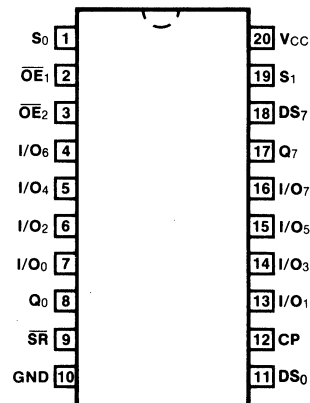
The 'F323 is an 8-bit universal shift/storage register with 3-state outputs. Its function is similar to the 'F299 with the exception of Synchronous Reset. Parallel load inputs and flip-flop outputs are multiplexed to minimize pin count. Separate serial inputs and outputs are provided for  $Q_0$  and  $Q_7$  to allow easy cascading. Four operation modes are possible: hold (store), shift left, shift right and parallel load.

- **Common Parallel I/O for Reduced Pin Count**
- **Additional Serial Inputs and Outputs for Expansion**
- **Four Operating Modes: Shift Left, Shift Right, Load and Store**
- **3-State Outputs for Bus Oriented Applications**

**Ordering Code:** See Section 6

Pkgs	Commercial Grade	Military Grade	Pkg Type
	$V_{CC} = +5.0\text{ V} \pm 5\%$ , $T_A = 0^\circ\text{ C to } +70^\circ\text{ C}$	$V_{CC} = +5.0\text{ V} \pm 10\%$ , $T_A = -55^\circ\text{ C to } +125^\circ\text{ C}$	
Plastic DIP (P)	74F323PC		9Z
Ceramic DIP (D)	74F323DC	54F323DM	4E
Flatpak (F)		54F323FM	4D

## Connection Diagram



**Input Loading/Fan-Out:** See Section 3 for U.L. definitions

Pin Names	Description	54F/74F (U.L.) HIGH/LOW
CP	Clock Pulse Input (Active Rising Edge)	0.5/0.375
DS <sub>0</sub>	Serial Data Input for Right Shift	0.5/0.375
DS <sub>7</sub>	Serial Data Input for Left Shift	0.5/0.375
S <sub>0</sub> , S <sub>1</sub>	Mode Select Inputs	0.5/0.75
SR	Synchronous Reset Input (Active LOW)	0.5/0.375
OE <sub>1</sub> , OE <sub>2</sub>	3-State Output Enable Inputs (Active LOW)	0.5/0.375
I/O <sub>0</sub> - I/O <sub>7</sub>	Multiplexed Parallel Data Inputs or 3-State Parallel Data Outputs	0.5/0.75 25/12.5
Q <sub>0</sub> , Q <sub>7</sub>	Serial Outputs	25/12.5

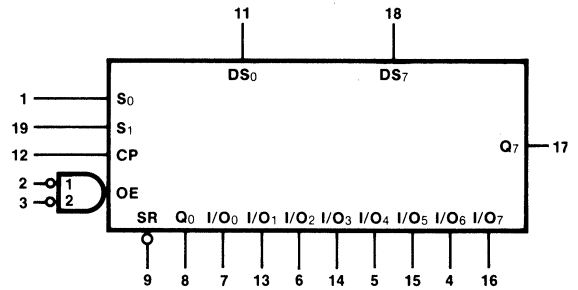
**Functional Description**

The 'F323 contains eight edge-triggered D-type flip-flops and the interstage logic necessary to perform synchronous reset, shift left, shift right, parallel load and hold operations. The type of operation is determined by  $S_0$  and  $S_1$  as shown in the Mode Select Table. All flip-flop outputs are brought out through 3-state buffers to separate I/O pins that also serve as data inputs in the parallel load mode.  $Q_0$  and  $Q_7$  are also brought out on other pins for expansion in serial shifting of longer words.

A LOW signal on  $\overline{SR}$  overrides the Select inputs and allows the flip-flops to be reset by the next rising edge of CP. All other state changes are also initiated by the LOW-to-HIGH CP transition. Inputs can change when the clock is in either state provided only that the recommended setup and hold times, relative to the rising edge of CP, are observed.

A HIGH signal on either  $\overline{OE}_1$  or  $\overline{OE}_2$  disables the 3-state buffers and puts the I/O pins in the high impedance state. In this condition the shift, load, hold and reset operations can still occur. The 3-state buffers are also disabled by HIGH signals on both  $S_0$  and  $S_1$  in preparation for a parallel load operation.

**Logic Symbol**



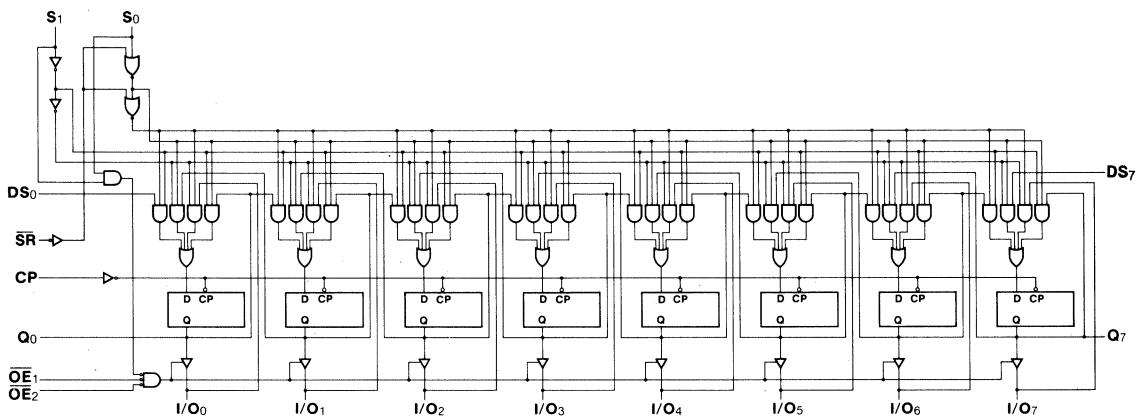
$V_{CC}$  = Pin 20  
 $GND$  = Pin 10

**Mode Select Table**

INPUTS				RESPONSE
$\overline{SR}$	$S_1$	$S_0$	CP	
L	X	X		Synchronous Reset; $Q_0 - Q_7 = \text{LOW}$
H	H	H		Parallel Load; $I/O_n - Q_n$
H	L	H		Shift Right; $DS_0 \rightarrow Q_0, Q_0 \rightarrow Q_1, \text{etc.}$
H	H	L		Shift Left; $DS_7 \rightarrow Q_7, Q_7 \rightarrow Q_6, \text{etc.}$
H	H	H	X	Hold

H = HIGH Voltage Level  
 L = LOW Voltage Level  
 X = Immaterial

**Logic Diagram**



**DC Characteristics over Operating Temperature Range** (unless otherwise specified)

Symbol	Parameter	54F/74F			Units	Conditions
		Min	Typ	Max		
I <sub>CC</sub>	Power Supply Current		66	92	mA	V <sub>CC</sub> = Max, CP = HIGH Outputs Disabled
I <sub>IH</sub>	Input HIGH Current Breakdown Test, I/O <sub>0</sub> - I/O <sub>7</sub>			100	μA	V <sub>CC</sub> = Max, V <sub>IN</sub> = 5.5 V
I <sub>IH</sub> + I <sub>ozH</sub>	3-State Output OFF Current HIGH, I/O <sub>0</sub> - I/O <sub>7</sub>			70	μA	V <sub>CC</sub> = Max, V <sub>OUT</sub> = 2.4 V
I <sub>IL</sub> + I <sub>ozL</sub>	3-State Output OFF Current LOW, I/O <sub>0</sub> - I/O <sub>7</sub>			-650	μA	V <sub>CC</sub> = Max, V <sub>OUT</sub> = 0.5 V

**AC Characteristics:** See Section 3 for waveforms and load configurations

4

Symbol	Parameter	54F/74F			54F		74F		Units	Fig. No.
		T <sub>A</sub> = +25°C, V <sub>CC</sub> = +5.0 V C <sub>L</sub> = 50 pF			T <sub>A</sub> , V <sub>CC</sub> = Mil C <sub>L</sub> = 50 pF		T <sub>A</sub> , V <sub>CC</sub> = Com C <sub>L</sub> = 50 pF			
		Min	Typ	Max	Min	Max	Min	Max		
f <sub>max</sub>	Maximum Input Frequency	70						MHz	3-1, 3-7	
t <sub>PLH</sub> t <sub>PHL</sub>	Propagation Delay CP to Q <sub>0</sub> or Q <sub>7</sub>	5.5 5.5	10 10	14 14				ns	3-1 3-7	
t <sub>PLH</sub> t <sub>PHL</sub>	Propagation Delay CP to I/O <sub>n</sub>	5.5 5.5	10 10	14 14				ns	3-1 3-12 3-13	
t <sub>PZH</sub> t <sub>PZL</sub>	Output Enable Time	6.0 6.0	10 10	14 14				ns	3-1 3-12 3-13	
t <sub>PHZ</sub> t <sub>PLZ</sub>	Output Disable Time	4.0 4.0	7.0 7.0	10 10				ns	3-1 3-12 3-13	

■ Test limits in screened columns are preliminary.



**AC Operating Requirements:** See Section 3 for waveforms

Symbol	Parameter	54F/74F			54F		74F		Units	Fig. No.
		T <sub>A</sub> = +25°C, V <sub>CC</sub> = +5.0 V			T <sub>A</sub> , V <sub>CC</sub> = Mil		T <sub>A</sub> , V <sub>CC</sub> = Com			
		Min	Typ	Max	Min	Max	Min	Max		
t <sub>s</sub> (H) t <sub>s</sub> (L)	Setup Time, HIGH or LOW S <sub>0</sub> or S <sub>1</sub> to CP	12							ns	3-5
t <sub>h</sub> (H) t <sub>h</sub> (L)	Hold Time, HIGH or LOW S <sub>0</sub> or S <sub>1</sub> to CP	0								
t <sub>s</sub> (H) t <sub>s</sub> (L)	Setup Time, HIGH or LOW I/O <sub>n</sub> , DS <sub>0</sub> , DS <sub>7</sub> to CP	5.0							ns	3-5
t <sub>h</sub> (H) t <sub>h</sub> (L)	Hold Time, HIGH or LOW I/O <sub>n</sub> , DS <sub>0</sub> , DS <sub>7</sub> to CP	0								
t <sub>s</sub> (H) t <sub>s</sub> (L)	Setup Time, HIGH or LOW SR to CP	15							ns	3-5
t <sub>h</sub> (H) t <sub>h</sub> (L)	Hold Time, HIGH or LOW SR to CP	0								
t <sub>w</sub> (H) t <sub>w</sub> (L)	CP Pulse Width, HIGH or LOW	7.0							ns	3-7

■ Test limits in screened columns are preliminary.

# 54F/74F350

## 4-Bit Shifter

(With 3-State Outputs)

### Description

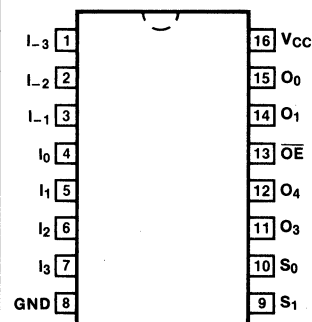
The 'F350 is a specialized multiplexer that accepts a 4-bit word and shifts it 0, 1, 2 or 3 places, as determined by two Select ( $S_0$ ,  $S_1$ ) inputs. For expansion to longer words, three linking inputs are provided for lower-order bits; thus two packages can shift an 8-bit word, four packages a 16-bit word, etc. Shifting by more than three places is accomplished by paralleling the 3-state outputs of different packages and using the Output Enable ( $\overline{OE}$ ) inputs as a third Select level. With appropriate interconnections, the 'F350 can perform zero-backfill, sign-extend or end-around (barrel) shift functions.

- Linking Inputs for Word Expansion
- 3-State Outputs for Extending Shift Range

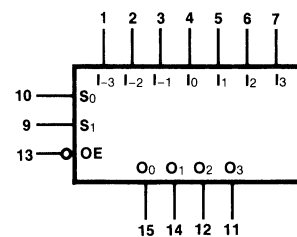
Ordering Code: See Section 6

Pkgs	Commercial Grade	Military Grade	Pkg Type
	$V_{CC} = +5.0\text{ V} \pm 5\%$ , $T_A = 0^\circ\text{C to } +70^\circ\text{C}$	$V_{CC} = +5.0\text{ V} \pm 10\%$ , $T_A = -55^\circ\text{C to } +125^\circ\text{C}$	
Plastic DIP (P)	74F350PC		9B
Ceramic DIP (D)	74F350DC	54F350DM	6B
Flatpak (F)		54F350FM	4L

### Connection Diagram



### Logic Symbol



$V_{CC} = \text{Pin } 16$   
 $\text{GND} = \text{Pin } 8$

Input Loading/Fan-Out: See Section 3 for U.L. definitions

Pin Names	Description	54F/74F (U.L.) HIGH/LOW
$S_0, S_1$	Select Inputs	0.5/0.75
$I_{-3} - I_3$	Data Inputs	0.5/0.75
$\overline{OE}$	Output Enable Input (Active LOW)	0.5/0.75
$O_0 - O_3$	3-State Outputs	25/12.5

## Functional Description

The 'F350 is operationally equivalent to a 4-input multiplexer with the inputs connected so that the select code causes successive one-bit shifts of the data word. This internal connection makes it possible to perform shifts of 0, 1, 2 or 3 places on words of any length.

A 7-bit data word is introduced at the  $I_n$  inputs and is shifted according to the code applied to the select inputs  $S_0, S_1$ . Outputs  $O_0 - O_3$  are 3-state, controlled by an active-LOW output enable ( $\overline{OE}$ ). When  $\overline{OE}$  is LOW, data outputs will follow selected data inputs; when HIGH, the data outputs will be forced to the high-impedance state. This feature allows shifters to be cascaded on the same output lines or to a common bus. The shift function can be logical, with zeros pulled in at either or both ends of the shifting field; arithmetic, where the sign bit is repeated during a shift down; or end around, where the data word forms a continuous loop.

## Logic Equations

$$O_0 = \overline{S_0} \overline{S_1} I_0 + S_0 \overline{S_1} I_{-1} + \overline{S_0} S_1 I_{-2} + S_0 S_1 I_{-3}$$

$$O_1 = \overline{S_0} \overline{S_1} I_1 + S_0 \overline{S_1} I_0 + \overline{S_0} S_1 I_{-1} + S_0 S_1 I_{-2}$$

$$O_2 = \overline{S_0} \overline{S_1} I_2 + S_0 \overline{S_1} I_1 + \overline{S_0} S_1 I_0 + S_0 S_1 I_{-1}$$

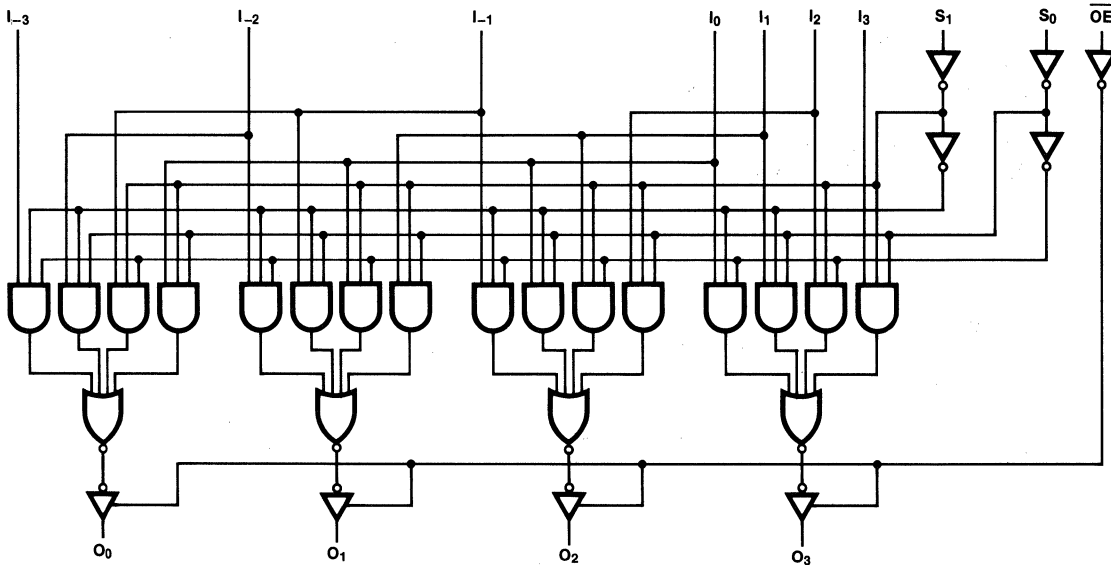
$$O_3 = \overline{S_0} \overline{S_1} I_3 + S_0 \overline{S_1} I_2 + \overline{S_0} S_1 I_1 + S_0 S_1 I_0$$

## Truth Table

INPUTS			OUTPUTS			
$\overline{OE}$	$S_1$	$S_0$	$O_0$	$O_1$	$O_2$	$O_3$
H	X	X	Z	Z	Z	Z
L	L	L	$I_0$	$I_1$	$I_2$	$I_3$
L	L	H	$I_{-1}$	$I_0$	$I_1$	$I_2$
L	H	L	$I_{-2}$	$I_{-1}$	$I_0$	$I_1$
L	H	H	$I_{-3}$	$I_{-2}$	$I_{-1}$	$I_0$

H = HIGH Voltage Level  
 L = LOW Voltage Level  
 Z = High Impedance  
 X = Immaterial

## Logic Diagram



**DC Characteristics over Operating Temperature Range** (unless otherwise specified)

Symbol	Parameter	54F/74F			Units	Conditions	
		Min	Typ	Max			
ICCH	Power Supply Current		22	35	mA	Outputs HIGH	V <sub>CC</sub> = Max
ICCL			26	41		Outputs LOW	
IC CZ			26	42		Outputs OFF	

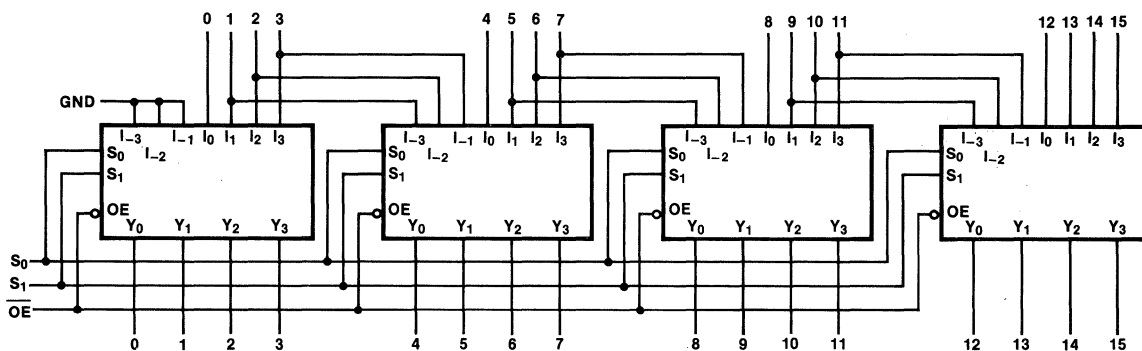
**AC Characteristics:** See Section 3 for waveforms and load configurations

Symbol	Parameter	54F/74F			54F		74F		Units	Fig. No.
		T <sub>A</sub> = +25°C, V <sub>CC</sub> = +5.0 V C <sub>L</sub> = 50 pF			T <sub>A</sub> , V <sub>CC</sub> = Mil C <sub>L</sub> = 50 pF		T <sub>A</sub> , V <sub>CC</sub> = Com C <sub>L</sub> = 50 pF			
		Min	Typ	Max	Min	Max	Min	Max		
t <sub>PLH</sub>	Propagation Delay	3.0	4.5	6.0	3.0	7.5	3.0	7.0	ns	3-1 3-4
t <sub>PHL</sub>	I <sub>n</sub> to O <sub>n</sub>	2.5	4.0	5.5	2.5	7.0	2.5	6.5		
t <sub>PLH</sub>	Propagation Delay	4.0	7.8	10	4.0	13	4.0	11	ns	3-1 3-10
t <sub>PHL</sub>	S <sub>n</sub> to O <sub>n</sub>	3.0	6.5	8.5	3.0	10	3.0	9.5		
t <sub>PZH</sub>	Output Enable Time	2.5	5.0	7.0	2.5	8.5	2.5	8.0	ns	3-1 3-12 3-13
t <sub>PZL</sub>		4.0	7.0	9.0	4.0	11	4.0	10		
t <sub>PHZ</sub>	Output Disable Time	2.0	3.9	5.5	2.0	7.0	2.0	6.5		
t <sub>PLZ</sub>		2.0	4.0	5.5	2.0	8.5	2.0	6.5		

■ Test limits in screened columns are preliminary.

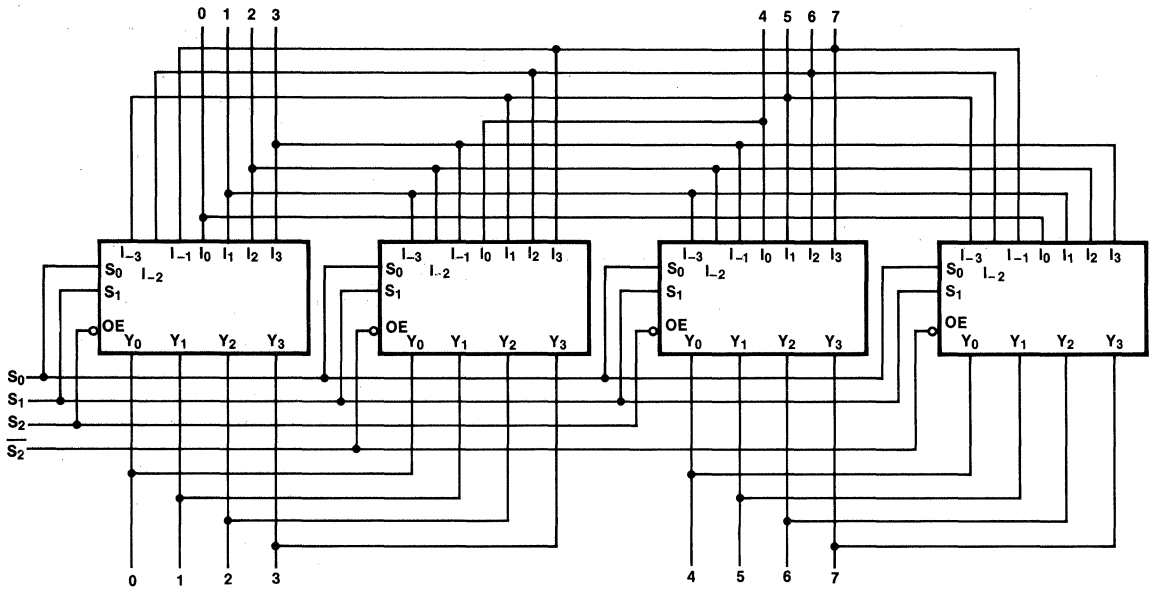
**Applications**

**16-Bit Shift-Up 0 to 3 Places, Zero Backfill**



- S<sub>1</sub> S<sub>0</sub>  
 L L NO SHIFT  
 L H SHIFT 1 PLACE  
 H L SHIFT 2 PLACES  
 H H SHIFT 3 PLACES

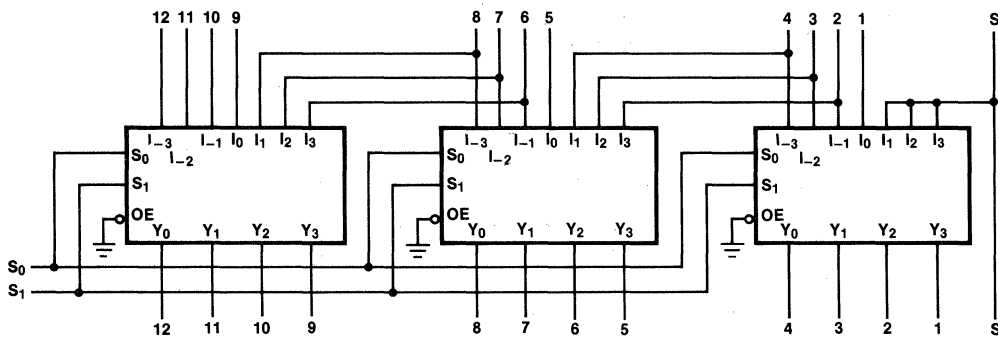
## 8-Bit End Around Shift 0 to 7 Places



S<sub>2</sub> S<sub>1</sub> S<sub>0</sub>

- L L L NO SHIFT
- L L H SHIFT END AROUND 1
- L H L SHIFT END AROUND 2
- L H H SHIFT END AROUND 3
- H L L SHIFT END AROUND 4
- H L H SHIFT END AROUND 5
- H H L SHIFT END AROUND 6
- H H H SHIFT END AROUND 7

## 13-Bit Twos Complement Scaler



S <sub>1</sub>	S <sub>0</sub>	SCALE
L	L + 8	1/8
L	H ÷ 4	1/4
H	L ÷ 2	1/2
H	H NO CHANGE	1

# 54F/74F352

## Dual 4-Input Multiplexer

### Description

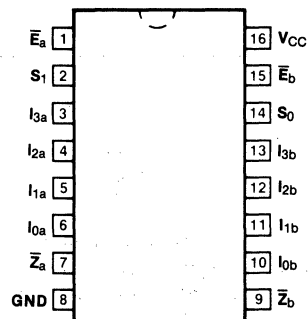
The 'F352 is a very high speed dual 4-input multiplexer with common Select inputs and individual Enable inputs for each section. It can select two bits of data from four sources. The two buffered outputs present data in the inverted (complementary) form. The 'F352 is the functional equivalent of the 'F153 except with inverted outputs.

- Inverted Version of the 'F153
- Separate Enables for Each Multiplexer
- Input Clamp Diode Limits High Speed Termination Effects

Ordering Code: See Section 6

Pkgs	Commercial Grade	Military Grade	Pkg Type
	$V_{CC} = +5.0\text{ V} \pm 5\%$ , $T_A = 0^\circ\text{ C to } +70^\circ\text{ C}$	$V_{CC} = +5.0\text{ V} \pm 10\%$ , $T_A = -55^\circ\text{ C to } +125^\circ\text{ C}$	
Plastic DIP (P)	74F352PC		9B
Ceramic DIP (D)	74F352DC	54F352DM	6B
Flatpak (F)		54F352FM	4L

### Connection Diagram

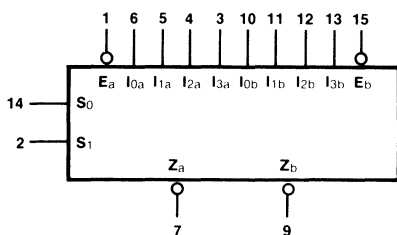


4

Input Loading/Fan-Out: See Section 3 for U.L. definitions

Pin Names	Description	54F/74F (U.L.) HIGH/LOW
$I_{0a} - I_{3a}$	Side A Data Inputs	0.5/0.375
$I_{0b} - I_{3b}$	Side B Data Inputs	0.5/0.375
$S_0, S_1$	Common Select Inputs	0.5/0.375
$\bar{E}_a$	Side A Enable Input (Active LOW)	0.5/0.375
$\bar{E}_b$	Side B Enable Input (Active LOW)	0.5/0.375
$Z_a, \bar{Z}_b$	Multiplexer Outputs (Inverted)	25/12.5

### Logic Symbol



$V_{CC} = \text{Pin } 16$   
 $GND = \text{Pin } 8$

**Functional Description**

The 'F352 is a dual 4-input multiplexer. It selects two bits of data from up to four sources under the control of the common Select inputs (S<sub>0</sub>, S<sub>1</sub>). The two 4-input multiplexer circuits have individual active-LOW Enables ( $\bar{E}_a$ ,  $\bar{E}_b$ ) which can be used to strobe the outputs independently. When the Enables ( $\bar{E}_a$ ,  $\bar{E}_b$ ) are HIGH, the corresponding outputs ( $\bar{Z}_a$ ,  $\bar{Z}_b$ ) are forced HIGH.

The logic equations for the outputs are shown below:

$$\bar{Z}_a = \bar{E}_a \cdot (I_{0a} \cdot \bar{S}_1 \cdot \bar{S}_0 + I_{1a} \cdot \bar{S}_1 \cdot S_0 + I_{2a} \cdot S_1 \cdot \bar{S}_0 + I_{3a} \cdot S_1 \cdot S_0)$$

$$\bar{Z}_b = \bar{E}_b \cdot (I_{0b} \cdot \bar{S}_1 \cdot \bar{S}_0 + I_{1b} \cdot \bar{S}_1 \cdot S_0 + I_{2b} \cdot S_1 \cdot \bar{S}_0 + I_{3b} \cdot S_1 \cdot S_0)$$

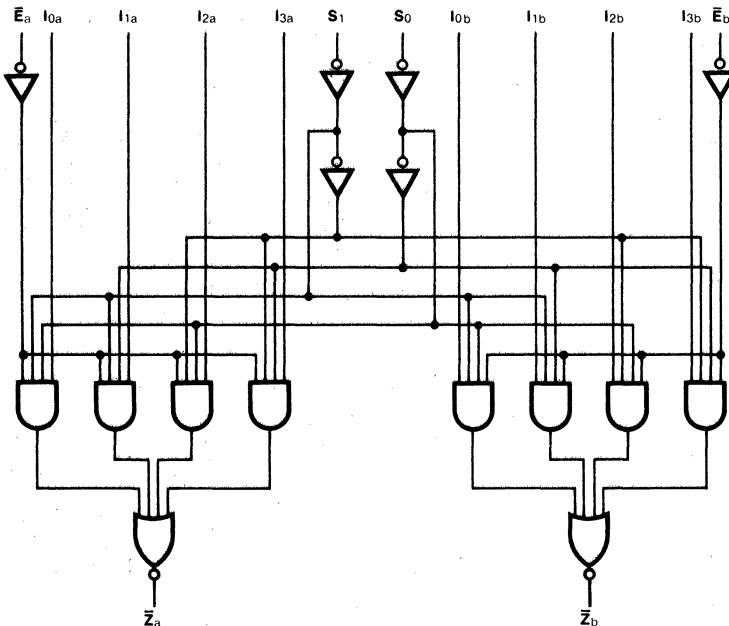
The 'F352 can be used to move data from a group of registers to a common output bus. The particular register from which the data came would be determined by the state of the Select inputs. A less obvious application is as a function generator. The 'F352 can generate two functions of three variables. This is useful for implementing highly irregular random logic.

**Truth Table**

SELECT INPUTS		$\bar{E}$	INPUTS (a or b)				OUTPUT
S <sub>0</sub>	S <sub>1</sub>		I <sub>0</sub>	I <sub>1</sub>	I <sub>2</sub>	I <sub>3</sub>	$\bar{Z}$
X	X	H	X	X	X	X	H
L	L	L	L	X	X	X	H
L	L	L	H	X	X	X	L
H	L	L	X	L	X	X	H
H	L	L	X	H	X	X	L
L	H	L	X	X	L	X	H
L	H	L	X	X	H	X	L
H	H	L	X	X	X	L	H
H	H	L	X	X	X	H	L

H = HIGH Voltage Level  
 L = LOW Voltage Level  
 X = Immaterial

**Logic Diagram**



**DC Characteristics Over Operating Temperature Range** (unless otherwise specified)

Symbol	Parameter	54F/74F			Units	Conditions	
		Min	Typ	Max			
ICCH ICCL	Power Supply Current		9.3 13.3	14 20	mA	V <sub>IN</sub> = Gnd V <sub>IN</sub> = HIGH	V <sub>CC</sub> = Max

**AC Characteristics:** See Section 3 for waveforms and load configurations

Symbol	Parameter	54F/74F			54F		74F		Units	Fig. No.
		T <sub>A</sub> = +25°C, V <sub>CC</sub> = +5.0 V C <sub>L</sub> = 50 pF			T <sub>A</sub> , V <sub>CC</sub> = Mil C <sub>L</sub> = 50 pF		T <sub>A</sub> , V <sub>CC</sub> = Com C <sub>L</sub> = 50 pF			
		Min	Typ	Max	Min	Max	Min	Max		
t <sub>PLH</sub> t <sub>PHL</sub>	Propagation Delay S <sub>n</sub> to $\bar{Z}_n$	4.0 4.0	7.4 7.0	13 13	3.5 3.5	14.5 15	4.0 4.0	14 14	ns	3-1 3-10
t <sub>PLH</sub> t <sub>PHL</sub>	Propagation Delay $\bar{E}_n$ to $\bar{Z}_n$	5.0 4.0	8.7 8.6	14 11	4.5 4.0	17 13	5.0 4.0	15 12	ns	3-1 3-4
t <sub>PLH</sub> t <sub>PHL</sub>	Propagation Delay I <sub>n</sub> to $\bar{Z}_n$	2.0 2.0	4.9 3.0	7.0 6.0	2.0 2.0	9.0 7.5	2.0 2.0	8.0 7.0	ns	3-1 3-3

■ Test limits in screened columns are preliminary.



# 54F/74F353

Dual 4-Input Multiplexer  
(With 3-State Outputs)

### Description

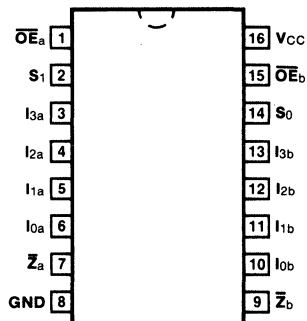
The 'F353 is a dual 4-input multiplexer with 3-state outputs. It can select two bits of data from four sources using common Select inputs. The outputs may be individually switched to a high impedance state with a HIGH on the respective Output Enable ( $\overline{OE}$ ) inputs, allowing the outputs to interface directly with bus oriented systems.

- Inverted Version of 'F253
- Multifunction Capability
- Separate Enables for Each Multiplexer

Ordering Code: See Section 6

Pkg	Commercial Grade	Military Grade	Pkg Type
	$V_{CC} = +5.0\text{ V} \pm 5\%$ , $T_A = 0^\circ\text{ C to } +70^\circ\text{ C}$	$V_{CC} = +5.0\text{ V} \pm 10\%$ , $T_A = -55^\circ\text{ C to } +125^\circ\text{ C}$	
Plastic DIP (P)	74F353PC		9B
Ceramic DIP (D)	74F353DC	54F353DM	6B
Flatpak (F)		54F353FM	4L

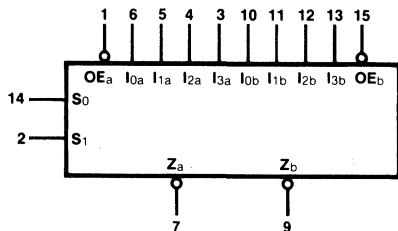
### Connection Diagram



Input Loading/Fan-Out: See Section 3 for U.L. definitions

Pin Names	Description	54F/74F (U.L.) HIGH/LOW
$I_{0a} - I_{3a}$	Side A Data Inputs	0.5/0.375
$I_{0b} - I_{3b}$	Side B Data Inputs	0.5/0.375
$S_0, S_1$	Common Select Inputs	0.5/0.375
$\overline{OE}_a$	Side A Output Enable Input (Active LOW)	0.5/0.375
$\overline{OE}_b$	Side B Output Enable Input (Active LOW)	0.5/0.375
$Z_a, Z_b$	3-State Outputs (Inverted)	25/12.5

### Logic Symbol



$V_{CC}$  = Pin 16  
GND = Pin 8

**Functional Description**

The 'F353 contains two identical 4-input multiplexers with 3-state outputs. They select two bits from four sources selected by common Select inputs (S<sub>0</sub>, S<sub>1</sub>). The 4-input multiplexers have individual Output Enable ( $\overline{OE}_a$ ,  $\overline{OE}_b$ ) inputs which, when HIGH, force the outputs to a high impedance (high Z) state. The logic equations for the outputs are shown below:

$$\begin{aligned} \overline{Z}_a &= \overline{OE}_a \cdot (I_{0a} \cdot \overline{S}_1 \cdot \overline{S}_0 + I_{1a} \cdot \overline{S}_1 \cdot S_0 + \\ &\quad I_{2a} \cdot S_1 \cdot \overline{S}_0 + I_{3a} \cdot S_1 \cdot S_0) \\ \overline{Z}_b &= \overline{OE}_b \cdot (I_{0b} \cdot \overline{S}_1 \cdot \overline{S}_0 + I_{1b} \cdot \overline{S}_1 \cdot S_0 + \\ &\quad I_{2b} \cdot S_1 \cdot \overline{S}_0 + I_{3b} \cdot S_1 \cdot S_0) \end{aligned}$$

If the outputs of 3-state devices are tied together, all but one device must be in the high impedance state to avoid high currents that would exceed the maximum ratings. Designers should ensure that Output Enable signals to 3-state devices whose outputs are tied together are designed so that there is no overlap.

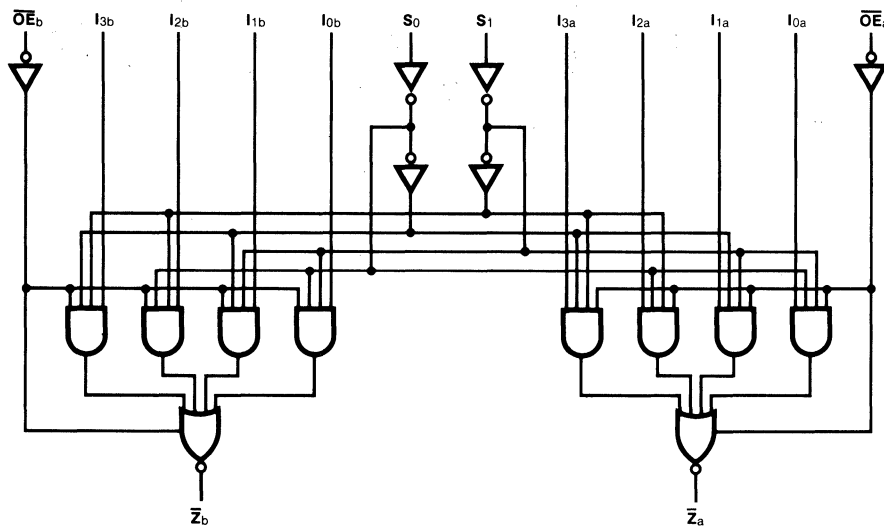
**Truth Table**

SELECT INPUTS		DATA INPUTS				OUTPUT ENABLE	OUTPUT
S <sub>0</sub>	S <sub>1</sub>	I <sub>0</sub>	I <sub>1</sub>	I <sub>2</sub>	I <sub>3</sub>	$\overline{OE}$	$\overline{Z}$
X	X	X	X	X	X	H	(Z)
L	L	L	X	X	X	L	H
L	L	H	X	X	X	L	L
H	L	X	L	X	X	L	H
H	L	X	H	X	X	L	L
L	H	X	X	L	X	L	H
L	H	X	X	H	X	L	L
H	H	X	X	X	L	L	H
H	H	X	X	X	H	L	L

Address inputs S<sub>0</sub> and S<sub>1</sub> are common to both sections.

H = HIGH Voltage Level  
 L = LOW Voltage Level  
 X = Immaterial  
 (Z) = High Impedance

**Logic Diagram**



**DC Characteristics Over Operating Temperature Range** (unless otherwise specified)

Symbol	Parameter	54F/74F			Units	Conditions	
		Min	Typ	Max			
ICCH	Power Supply Current		9.3	14	mA	I <sub>n</sub> , S <sub>n</sub> , $\overline{OE}_n = \text{Gnd}$	
ICCL			13.3	20		I <sub>n</sub> , S <sub>n</sub> = Gnd	V <sub>CC</sub> = Max
IC CZ			15	23		$\overline{OE}_n = 4.5 \text{ V}$	

**AC Characteristics:** See Section 3 for waveforms and load configurations

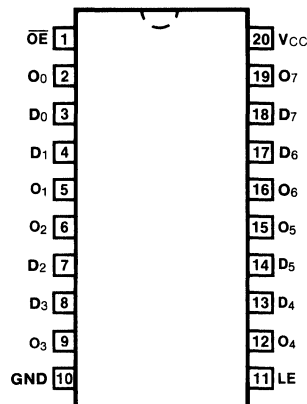
Symbol	Parameter	54F/74F			54F		74F		Units	Fig. No.
		T <sub>A</sub> = +25°C, V <sub>CC</sub> = +5.0 V, C <sub>L</sub> = 50 pF			T <sub>A</sub> , V <sub>CC</sub> = Mil, C <sub>L</sub> = 50 pF		T <sub>A</sub> , V <sub>CC</sub> = Com, C <sub>L</sub> = 50 pF			
		Min	Typ	Max	Min	Max	Min	Max		
tPLH	Propagation Delay S <sub>n</sub> to $\overline{Z}_n$	5.0	8.8	14	5.0	16	5.0	15	ns	3-1 3-10
tPHL		4.0	7.4	11	4.0	14	4.0	12		
tPLH	Propagation Delay I <sub>n</sub> to $\overline{Z}_n$	3.0	5.6	7.0	3.0	9.0	3.0	8.0	ns	3-1 3-3
tPHL		2.0	2.8	6.0	2.0	7.5	2.0	7.0		
tPZH	Output Enable Time	3.0	6.8	9.0	3.0	11	3.0	10	ns	3-1 3-12
tPZL		3.0	7.2	9.5	3.0	12	3.0	10.5		
tPHZ	Output Disable Time	2.0	3.7	5.0	2.0	6.5	2.0	6.0	ns	3-13
tPLZ		2.0	4.4	6.0	2.0	8.5	2.0	7.0		

■ Test limits in screened columns are preliminary.

# 54F/74F373

Octal Transparent Latch  
(With 3-State Outputs)

## Connection Diagram



### Description

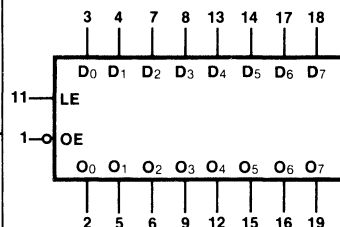
The 'F373 consists of eight latches with 3-state outputs for bus organized system applications. The flip-flops appear transparent to the data when Latch Enable (LE) is HIGH. When LE is LOW, the data that meets the setup times is latched. Data appears on the bus when the Output Enable ( $\overline{OE}$ ) is LOW. When  $\overline{OE}$  is HIGH the bus output is in the high impedance state.

- Eight Latches in a Single Package
- 3-State Outputs for Bus Interfacing

Ordering Code: See Section 6

Pkgs	Commercial Grade	Military Grade	Pkg Type
	$V_{CC} = +5.0\text{ V} \pm 5\%$ , $T_A = 0^\circ\text{ C to } +70^\circ\text{ C}$	$V_{CC} = +5.0\text{ V} \pm 10\%$ , $T_A = -55^\circ\text{ C to } +125^\circ\text{ C}$	
Plastic DIP (P)	74F373PC		9Z
Ceramic DIP (D)	74F373DC	54F373DM	4E
Flatpak (F)		54F373FM	4D

### Logic Symbol



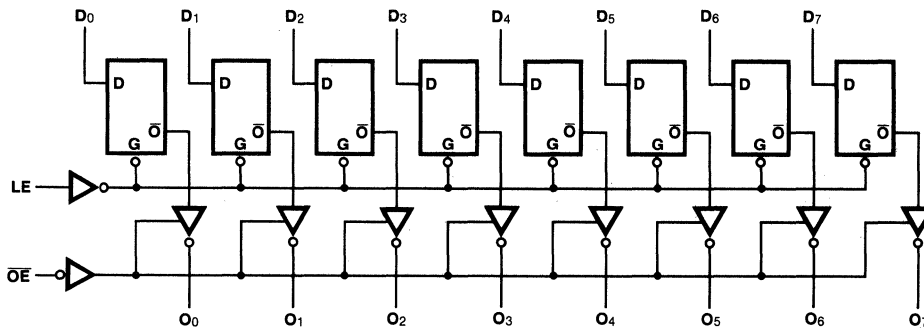
$V_{CC}$  = Pin 20  
GND = Pin 10

Input Loading/Fan-Out: See Section 3 for U.L. definitions

Pin Names	Description	54F/74F (U.L.) HIGH/LOW
D <sub>0</sub> - D <sub>7</sub>	Data Inputs	0.5/0.375
LE	Latch Enable Input (Active HIGH)	0.5/0.375
$\overline{OE}$	Output Enable Input (Active LOW)	0.5/0.375
O <sub>0</sub> - O <sub>7</sub>	3-State Latch Outputs	25/12.5

**Functional Description**

The 'F373 contains eight D-type latches with 3-state output buffers. When the Latch Enable (LE) input is HIGH, data on the  $D_n$  inputs enters the latches. In this condition the latches are transparent, i.e., a latch output will change state each time its D input changes. When LE is LOW the latches store the information that was present on the D inputs a setup time preceding the HIGH-to-LOW transition of LE. The 3-state buffers are controlled by the Output Enable ( $\overline{OE}$ ) input. When  $\overline{OE}$  is LOW, the buffers are in the bi-state mode. When  $\overline{OE}$  is HIGH the buffers are in the high impedance mode but this does not interfere with entering new data into the latches.

**Logic Diagram**

Please note that this diagram is provided only for the understanding of logic operations and should not be used to estimate propagation delays.

**DC Characteristics over Operating Temperature Range** (unless otherwise specified)

Symbol	Parameter	54F/74F			Units	Conditions
		Min	Typ	Max		
I <sub>CCZ</sub>	Power Supply Current (All Outputs OFF)		35	55	mA	V <sub>CC</sub> = Max, $\overline{OE}$ = 4.5 V D <sub>n</sub> , LE = Gnd

**AC Characteristics:** See Section 3 for waveforms and load configurations

Symbol	Parameter	54F/74F			54F		74F		Units	Fig. No.
		T <sub>A</sub> = +25°C, V <sub>CC</sub> = +5.0 V C <sub>L</sub> = 50 pF			T <sub>A</sub> , V <sub>CC</sub> = Mil C <sub>L</sub> = 50 pF		T <sub>A</sub> , V <sub>CC</sub> = Com C <sub>L</sub> = 50 pF			
		Min	Typ	Max	Min	Max	Min	Max		
t <sub>PLH</sub> t <sub>PHL</sub>	Propagation Delay D <sub>n</sub> to O <sub>n</sub>	3.0 2.0	5.3 3.7	7.0 5.0	3.0 2.0	8.5 6.0	3.0 2.0	8.0 6.0	ns	3-2 3-4
t <sub>PLH</sub> t <sub>PHL</sub>	Propagation Delay LE to O <sub>n</sub>	5.0 3.0	9.0 5.2	11.5 7.0	5.0 3.0	15 8.5	5.0 3.0	13 8.0	ns	3-2 3-7
t <sub>PZH</sub> t <sub>PZL</sub>	Output Enable Time	2.0 2.0	5.0 5.6	11 7.5	2.0 2.0	13.5 10	2.0 2.0	12 8.5	ns	3-2 3-12 3-13
t <sub>PHZ</sub> t <sub>PLZ</sub>	Output Disable Time	2.0 2.0	4.5 3.8	6.5 5.0	2.0 2.0	10 7.0	2.0 2.0	7.5 6.0	ns	3-2 3-12 3-13

**AC Operating Requirements:** See Section 6 for waveforms

Symbol	Parameter	54F/74F			54F		74F		Units	Fig. No.
		T <sub>A</sub> = +25°C, V <sub>CC</sub> = +5.0 V			T <sub>A</sub> , V <sub>CC</sub> = Mil		T <sub>A</sub> , V <sub>CC</sub> = Com			
		Min	Typ	Max	Min	Max	Min	Max		
t <sub>s</sub> (H) t <sub>s</sub> (L)	Setup Time, HIGH or LOW D <sub>n</sub> to LE	2.0 2.0			2.0 2.0		2.0 2.0		ns	3-15
t <sub>h</sub> (H) t <sub>h</sub> (L)	Hold Time, HIGH or LOW D <sub>n</sub> to LE	3.0 3.0			3.0 3.0		3.0 3.0			
t <sub>w</sub> (H)	LE Pulse Width HIGH	6.0			6.0		6.0		ns	3-7

# 54F/74F374

Octal D-Type Flip-Flop  
(With 3-State Outputs)

**Description**

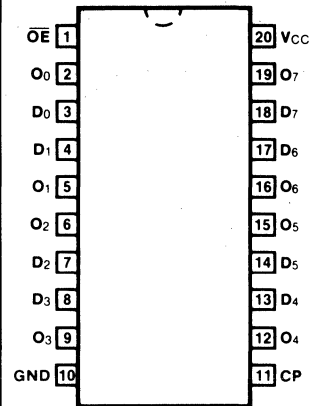
The 'F374 is a high-speed, low-power octal D-type flip-flop featuring separate D-type inputs for each flip-flop and 3-state outputs for bus oriented applications. A buffered Clock (CP) and Output Enable ( $\overline{OE}$ ) are common to all flip-flops.

- Edge-triggered D-Type Inputs
- Buffered Positive Edge-triggered Clock
- 3-State Outputs for Bus Oriented Applications

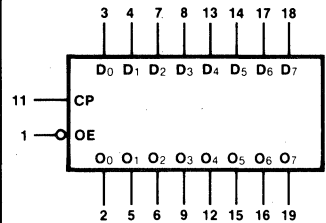
Ordering Code: See Section 6

Pkg	Commercial Grade	Military Grade	Pkg Type
	$V_{CC} = +5.0\text{ V} \pm 5\%$ , $T_A = 0^\circ\text{C to } +70^\circ\text{C}$	$V_{CC} = +5.0\text{ V} \pm 10\%$ , $T_A = -55^\circ\text{C to } +125^\circ\text{C}$	
Plastic DIP (P)	74F374PC		9Z
Ceramic DIP (D)	74F374DC	54F374DM	4E
Flatpak (F)		54F374FM	4D

**Connection Diagram**



**Logic Symbol**

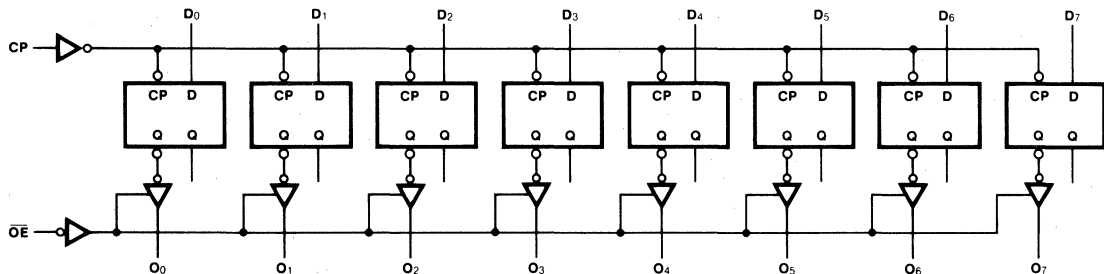


$V_{CC}$  = Pin 20  
 $GND$  = Pin 10

Input Loading/Fan-Out: See Section 3 for U.L. definitions

Pin Names	Description	54F/74F (U.L.) HIGH/LOW
D <sub>0</sub> - D <sub>7</sub>	Data Inputs	0.5/0.375
CP	Clock Pulse Input (Active Rising Edge)	0.5/0.375
$\overline{OE}$	3-State Output Enable Input (Active LOW)	0.5/0.375
O <sub>0</sub> - O <sub>7</sub>	3-State Outputs	25/12.5



**Logic Diagram**



**Functional Description**

The 'F374 consists of eight edge-triggered flip-flops with individual D-type inputs and 3-state true outputs. The buffered clock and buffered Output Enable are common to all flip-flops. The eight flip-flops will store the state of their individual D inputs that meet the setup and hold times requirements on the LOW-to-HIGH Clock (CP) transition. With the Output Enable ( $\overline{OE}$ ) LOW, the contents of the eight flip-flops are available at the outputs. When the  $\overline{OE}$  is HIGH, the outputs go to the high impedance state. Operation of the  $\overline{OE}$  input does not affect the state of the flip-flops.

**Truth Table**

INPUTS		OUTPUTS	
D <sub>n</sub>	CP	$\overline{OE}$	O <sub>n</sub>
H		L	H
L		L	L
X	X	H	Z

H = HIGH Voltage Level

L = LOW Voltage Level

X = Immaterial

Z = High Impedance

**DC Characteristics over Operating Temperature Range** (unless otherwise specified)

Symbol	Parameter	54F/74F			Units	Conditions
		Min	Typ	Max		
I <sub>CC</sub> L	Power Supply Current (All Outputs OFF)		55	86	mA	V <sub>CC</sub> = Max, D <sub>n</sub> = Gnd $\overline{OE}$ = 4.5 V

**AC Characteristics:** See Section 3 for waveforms and load configurations

Symbol	Parameter	54F/74F			54F		74F		Units	Fig. No.
		T <sub>A</sub> = +25°C, V <sub>CC</sub> = +5.0 V C <sub>L</sub> = 50 pF			T <sub>A</sub> , V <sub>CC</sub> = Mil C <sub>L</sub> = 50 pF		T <sub>A</sub> , V <sub>CC</sub> = Com C <sub>L</sub> = 50 pF			
		Min	Typ	Max	Min	Max	Min	Max		
f <sub>max</sub>	Maximum Clock Frequency	100			60		70	MHz	3-1, 3-7	
t <sub>PLH</sub> t <sub>PHL</sub>	Propagation Delay CP to O <sub>n</sub>	4.0	6.5	8.5	4.0	10.5	4.0	10	ns	3-1 3-7
t <sub>PZH</sub> t <sub>PZL</sub>	Output Enable Time	2.0	9.0	11.5	2.0	14	2.0	12.5	ns	3-1 3-12
t <sub>PHZ</sub> t <sub>PLZ</sub>	Output Disable Time	2.0	5.3	7.0	2.0	8.0	2.0	8.0		
		2.0	4.3	5.5	2.0	7.5	2.0	6.5		3-13

**AC Operating Requirements:** See Section 3 for waveforms

Symbol	Parameter	54F/74F			54F		74F		Units	Fig. No.
		T <sub>A</sub> = +25°C, V <sub>CC</sub> = +5.0 V			T <sub>A</sub> , V <sub>CC</sub> = Mil		T <sub>A</sub> , V <sub>CC</sub> = Com			
		Min	Typ	Max	Min	Max	Min	Max		
t <sub>s</sub> (H) t <sub>s</sub> (L)	Setup Time, HIGH or LOW D <sub>n</sub> to CP	2.0			2.5		2.0		ns	3-5
t <sub>h</sub> (H) t <sub>h</sub> (L)	Hold Time, HIGH or LOW D <sub>n</sub> to CP	2.0			2.0		2.0			
t <sub>w</sub> (H) t <sub>w</sub> (L)	CP Pulse Width, HIGH or LOW	7.0			7.0		7.0		ns	3-7
		6.0			6.0		6.0			



# 54F/74F378

Parallel D Register  
(With Enable)

### Description

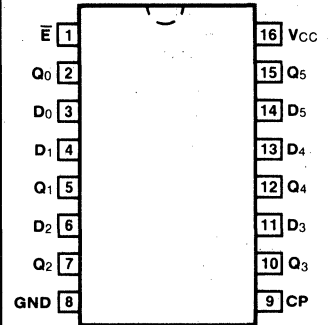
The 'F378 is a 6-bit register with a buffered common enable. This device is similar to the 'F174, but with common Enable rather than common Master Reset.

- 6-Bit High-speed Parallel Register
- Positive Edge-Triggered D-Type Inputs
- Fully Buffered Common Clock and Enable Inputs
- Input Clamp Diodes Limit High Speed Termination Effects
- Full TTL and CMOS Compatible

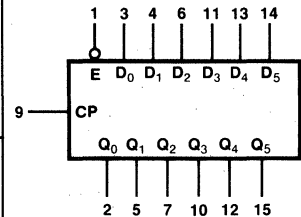
Ordering Code: See Section 6

Pkgs	Commercial Grade	Military Grade	Pkg Type
	$V_{CC} = +5.0\text{ V} \pm 5\%$ , $T_A = 0^\circ\text{C to } +70^\circ\text{C}$	$V_{CC} = +5.0\text{ V} \pm 10\%$ , $T_A = -55^\circ\text{C to } +125^\circ\text{C}$	
Plastic DIP (P)	74F378PC		9B
Ceramic DIP (D)	74F378DC	54F378DM	6B
Flatpak (F)		54F378FM	4L

### Connection Diagram



### Logic Symbol



$V_{CC}$  = Pin 16  
GND = Pin 8

Input Loading/Fan-Out: See Section 3 for U.L. definitions

Pin Names	Description	54F/74F (U.L.) HIGH/LOW
$\bar{E}$	Enable Input (Active LOW)	0.5/0.375
$D_0 - D_5$	Data Inputs	0.5/0.375
CP	Clock Pulse Input (Active Rising Edge)	0.5/0.375
$Q_0 - Q_5$	Outputs	25/12.5

**Functional Description**

The 'F378 consists of eight edge-triggered D-type flip-flops with individual D inputs and Q outputs. The Clock (CP) and Enable ( $\bar{E}$ ) inputs are common to all flip-flops.

When the  $\bar{E}$  input is LOW, new data is entered into the register on the LOW-to-HIGH transition of the CP input. When the  $\bar{E}$  input is HIGH the register will retain the present data independent of the CP input.

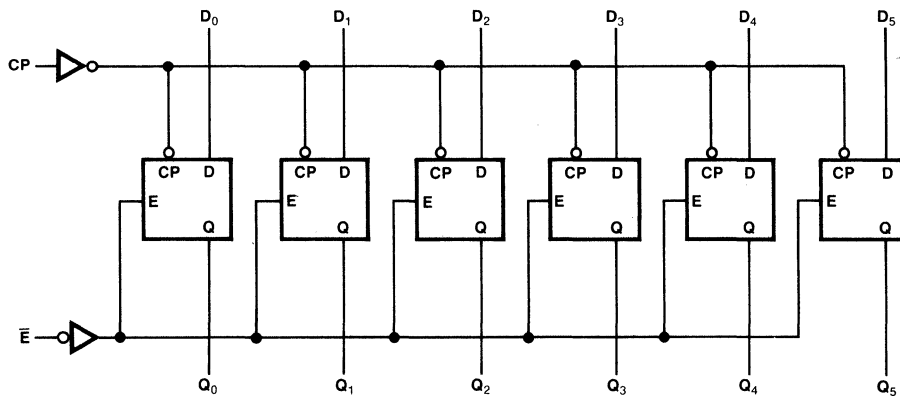
**Truth Table**

INPUTS			OUTPUT
$\bar{E}$	CP	$D_n$	$Q_n$
H		X	No change
L		H	H
L		L	L

H = HIGH Voltage Level

L = LOW Voltage Level

X = Immaterial

**Logic Diagram**

**DC Characteristics over Operating Temperature Range** (unless otherwise specified)

Symbol	Parameter	54F/74F			Units	Conditions
		Min	Typ	Max		
I <sub>CC</sub>	Power Supply Current		30	45	mA	V <sub>CC</sub> = Max, V <sub>CP</sub> = 0

**AC Characteristics:** See Section 3 for waveforms and load configurations

Symbol	Parameter	54F/74F			54F		74F		Units	Fig. No.
		T <sub>A</sub> = +25°C, V <sub>CC</sub> = +5.0 V C <sub>L</sub> = 50 pF			T <sub>A</sub> , V <sub>CC</sub> = Mil C <sub>L</sub> = 50 pF		T <sub>A</sub> , V <sub>CC</sub> = Com C <sub>L</sub> = 50 pF			
		Min	Typ	Max	Min	Max	Min	Max		
f <sub>max</sub>	Maximum Input Frequency	100	140					MHz	3-1, 3-7	
t <sub>PLH</sub> t <sub>PHL</sub>	Propagation Delay CP to Q <sub>n</sub>	3.5 4.5	5.5 7.0	8.0 10				ns	3-1, 3-7	

**AC Operating Requirements:** See Section 3 for waveforms

Symbol	Parameter	54F/74F			54F		74F		Units	Fig. No.
		T <sub>A</sub> = +25°C, V <sub>CC</sub> = +5.0 V			T <sub>A</sub> , V <sub>CC</sub> = Mil		T <sub>A</sub> , V <sub>CC</sub> = Com			
		Min	Typ	Max	Min	Max	Min	Max		
t <sub>s</sub> (H) t <sub>s</sub> (L)	Setup Time, HIGH or LOW D <sub>n</sub> to CP	4.0						ns	3-5	
t <sub>h</sub> (H) t <sub>h</sub> (L)	Hold Time, HIGH or LOW D <sub>n</sub> to CP	4.0								
t <sub>s</sub> (H) t <sub>s</sub> (L)	Setup Time, HIGH or LOW $\bar{E}$ to CP	6.0						ns	3-5	
t <sub>h</sub> (H) t <sub>h</sub> (L)	Hold Time, HIGH or LOW $\bar{E}$ to CP	6.0								
t <sub>w</sub> (H) t <sub>w</sub> (L)	CP Pulse Width, HIGH or LOW	4.0						ns	3-7	
		5.0								

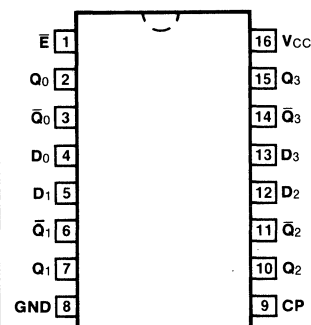
■ Test limits in screened columns are preliminary.

# 54F/74F379

## Quad Parallel Register

(With Enable)

### Connection Diagram



### Description

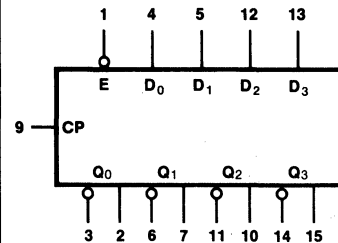
The 'F379 is a 4-bit register with buffered common Enable. This device is similar to the 'F175 but features the common Enable rather than common Master Reset.

- Edge-triggered D-Type Inputs
- Buffered Positive Edge-triggered Clock
- Buffered Common Enable Input
- True and Complement Outputs

**Ordering Code:** See Section 6

Pkgs	Commercial Grade	Military Grade	Pkg Type
	VCC = +5.0 V $\pm$ 5%, TA = 0°C to +70°C	VCC = +5.0 V $\pm$ 10%, TA = -55°C to +125°C	
Plastic DIP (P)	74F379PC		9B
Ceramic DIP (D)	74F379DC	54F379DM	6B
Flatpak (F)		54F379FM	4L

### Logic Symbol



VCC = Pin 16  
GND = Pin 8




**Input Loading/Fan-Out:** See Section 3 for U.L. definitions

Pin Names	Description	54F/74F (U.L.) HIGH/LOW
$\bar{E}$	Enable Input (Active LOW)	0.5/0.375
D <sub>0</sub> - D <sub>3</sub>	Data Inputs	0.5/0.375
CP	Clock Pulse Input (Active Rising Edge)	0.5/0.375
Q <sub>0</sub> - Q <sub>3</sub>	Flip-flop Outputs	25/12.5
$\bar{Q}_0$ - $\bar{Q}_3$	Complement Outputs	25/12.5

## Functional Description

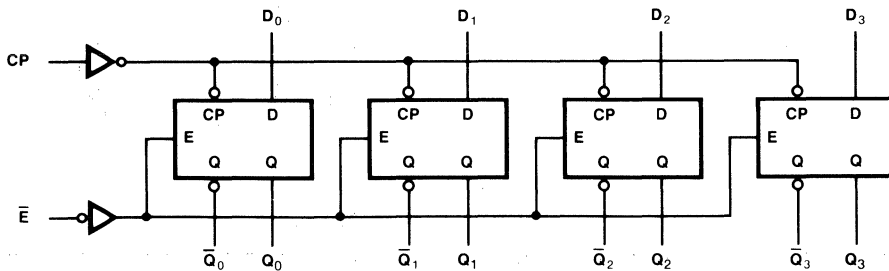
The 'F379 consists of four edge-triggered D-type flip-flops with individual D inputs and Q and  $\bar{Q}$  outputs. The Clock (CP) and Enable ( $\bar{E}$ ) inputs are common to all flip-flops. When the  $\bar{E}$  input is HIGH, the register will retain the present data independent of the CP input. The  $D_n$  and  $\bar{E}$  inputs can change when the clock is in either state, provided that the recommended setup and hold times are observed.

## Truth Table


INPUTS			OUTPUTS	
$\bar{E}$	CP	$D_n$	$Q_n$	$\bar{Q}_n$
H		X	NC	NC
L		H	H	L
L		L	L	H

H = HIGH Voltage Level      X = Immaterial  
 L = LOW Voltage Level      NC = No Change

## Logic Diagram



**DC Characteristics over Operating Temperature Range** (unless otherwise specified)

Symbol	Parameter	54F/74F			Units	Conditions
		Min	Typ	Max		
I <sub>CC</sub>	Power Supply Current		28	40	mA	V <sub>CC</sub> = Max; D, $\bar{E}$ = Gnd CP = 

**AC Characteristics:** See Section 3 for waveforms and load configurations

Symbol	Parameter	54F/74F			54F		74F		Units	Fig. No.
		T <sub>A</sub> = +25°C, V <sub>CC</sub> = +5.0 V C <sub>L</sub> = 50 pF			T <sub>A</sub> , V <sub>CC</sub> = Mil C <sub>L</sub> = 50 pF		T <sub>A</sub> , V <sub>CC</sub> = Com C <sub>L</sub> = 50 pF			
		Min	Typ	Max	Min	Max	Min	Max		
f <sub>max</sub>	Maximum Clock Frequency	100	140			100		MHz	3-1, 3-7	
t <sub>PLH</sub> t <sub>PHL</sub>	Propagation Delay CP to Q <sub>n</sub> , $\bar{Q}_n$	4.0 5.0	5.0 6.5	6.5 8.5		4.0 5.0	7.5 9.5	ns	3-1 3-7	

**AC Operating Requirements:** See Section 3 for waveforms

Symbol	Parameter	54F/74F			54F		74F		Units	Fig. No.
		T <sub>A</sub> = +25°C, V <sub>CC</sub> = +5.0 V			T <sub>A</sub> , V <sub>CC</sub> = Mil		T <sub>A</sub> , V <sub>CC</sub> = Com			
		Min	Typ	Max	Min	Max	Min	Max		
t <sub>s</sub> (H) t <sub>s</sub> (L)	Setup Time, HIGH or LOW D <sub>n</sub> to CP	3.0 3.0				3.0 3.0		ns	3-5	
t <sub>h</sub> (H) t <sub>h</sub> (L)	Hold Time, HIGH or LOW D <sub>n</sub> to CP	1.0 1.0				1.0 1.0				
t <sub>s</sub> (H) t <sub>s</sub> (L)	Setup Time, HIGH or LOW $\bar{E}$ to CP	6.0 6.0				6.0 6.0		ns	3-5	
t <sub>h</sub> (H) t <sub>h</sub> (L)	Hold Time, HIGH or LOW $\bar{E}$ to CP	0 0				0 0				
t <sub>w</sub> (H) t <sub>w</sub> (L)	CP Pulse Width, HIGH or LOW	4.0 5.0				4.0 5.0		ns	3-7	

# 54F/74F381

## 4-Bit Arithmetic Logic Unit

### Description

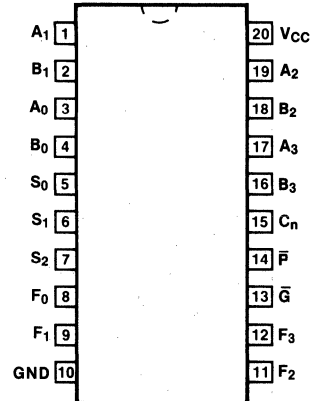
The 'F381 performs three arithmetic and three logic operations on two 4-bit words, A and B. Two additional Select input codes force the Function outputs LOW or HIGH. Carry Propagate and Generate outputs are provided for use with the 'F182 Carry Lookahead Generator for high-speed expansion to longer word lengths. For ripple expansion, refer to the 'F382 ALU data sheet.

- Low Input Loading Minimizes Drive Requirements
- Performs Six Arithmetic and Logic Functions
- Selectable Low (Clear) and High (Preset) Functions
- Carry Generate and Propagate Outputs for use with Carry Lookahead Generator

Ordering Code: See Section 6

Pkgs	Commercial Grade	Military Grade	Pkg Type
	$V_{CC} = +5.0\text{ V} \pm 5\%$ , $T_A = 0^\circ\text{ C to } +70^\circ\text{ C}$	$V_{CC} = +5.0\text{ V} \pm 10\%$ , $T_A = -55^\circ\text{ C to } +125^\circ\text{ C}$	
Plastic DIP (P)	74F381PC		9Z
Ceramic DIP (D)	74F381DC	54F381DM	4E
Flatpak (F)		54F381FM	4D

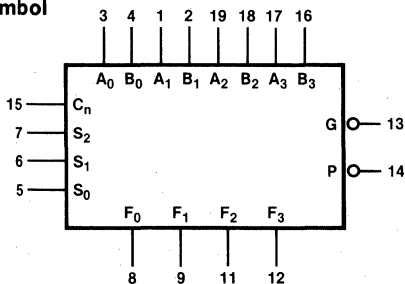
### Connection Diagram



Input Loading/Fan-Out: See Section 3 for U.L. definitions

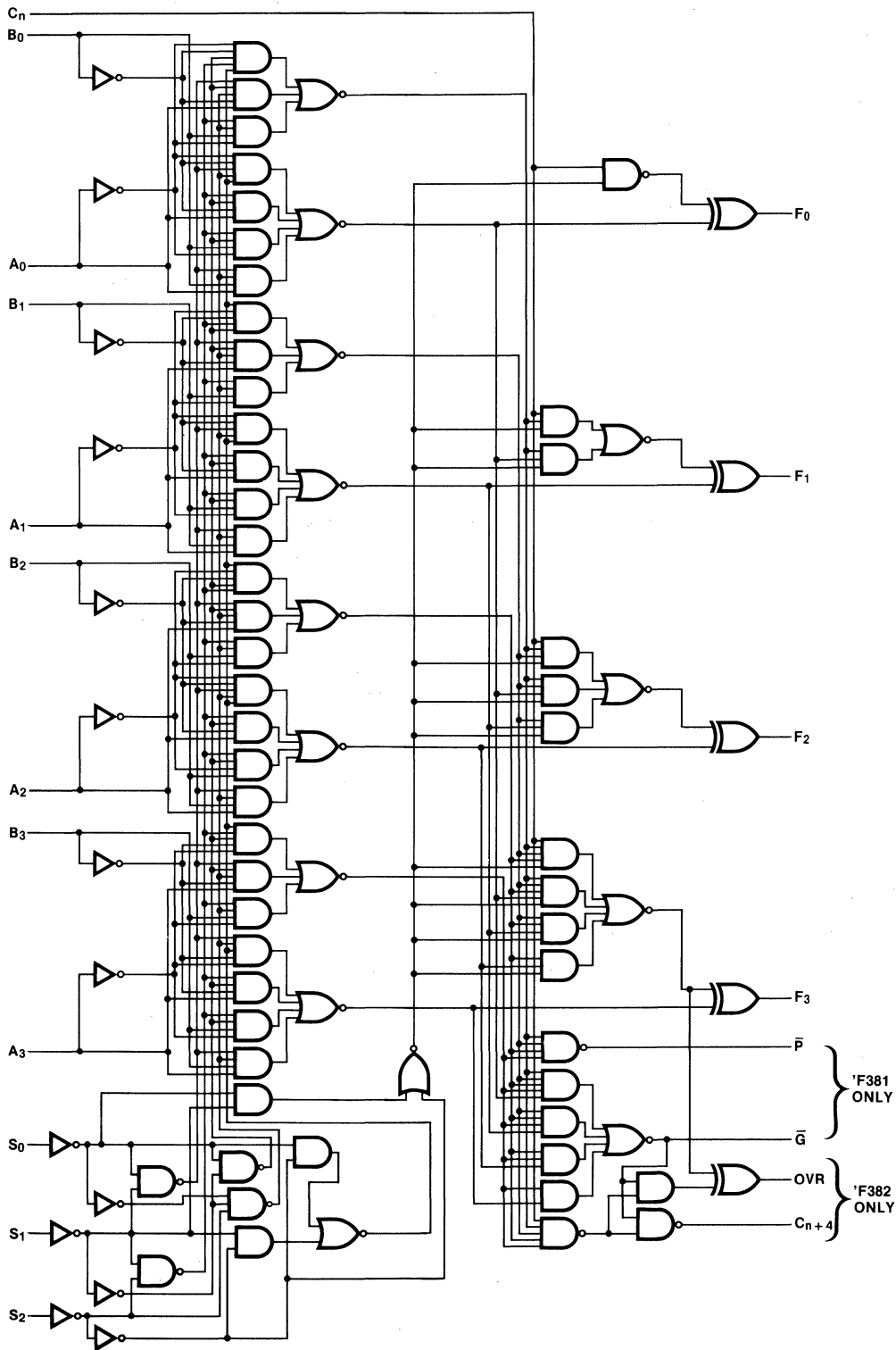
Pin Names	Description	54F/74F (U.L.) HIGH/LOW
A <sub>0</sub> - A <sub>3</sub>	A Operand Inputs	0.5/1.50
B <sub>0</sub> - B <sub>3</sub>	B Operand Inputs	0.5/1.50
S <sub>0</sub> - S <sub>2</sub>	Function Select Inputs	0.5/0.375
C <sub>n</sub>	Carry Input	0.5/1.50
$\overline{G}$	Carry Generate Output (Active LOW)	25/12.5
$\overline{P}$	Carry Propagate Output (Active LOW)	25/12.5
F <sub>0</sub> - F <sub>3</sub>	Function Outputs	25/12.5

### Logic Symbol



$V_{CC}$  = Pin 20  
GND = Pin 10

Logic Diagram





## Functional Description

Signals applied to the Select inputs  $S_0 - S_2$  determine the mode of operation, as indicated in the Function Select Table. An extensive listing of input and output levels is shown in the Truth Table. The circuit performs the arithmetic functions for either active-HIGH or active-LOW operands, with output levels in the same convention. In the Subtract operating modes, it is necessary to force a carry (HIGH for active-HIGH operands, LOW for active-LOW operands) into the  $C_n$  input of the least significant package.

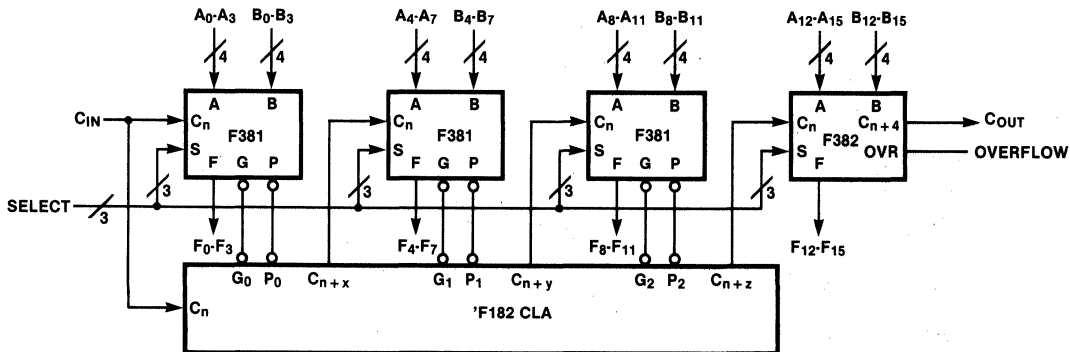
The Carry Generate ( $\overline{G}$ ) and Carry Propagate ( $\overline{P}$ ) outputs supply input signals to the 'F182 carry lookahead generator for expansion to longer word length, as shown in *Figure a*. Note that an 'F382 ALU is used for the most significant package. Typical delays for *Figure a* are given in *Figure b*.

## Function Select Table

SELECT			OPERATION
$S_0$	$S_1$	$S_2$	
L	L	L	Clear
H	L	L	B Minus A
L	H	L	A Minus B
H	H	L	A Plus B
L	L	H	$A \oplus B$
H	L	H	$A + B$
L	H	H	AB
H	H	H	Preset

H = HIGH Voltage Level    L = LOW Voltage Level

**Fig. a 16-Bit Lookahead Carry ALU Expansion**



**Fig. b 16-Bit Delay Tabulation**

PATH SEGMENT	TOWARD F	OUTPUT $C_{n+4}, OVR$
$A_i$ or $B_i$ to $\overline{P}$	7.2 ns	7.2 ns
$\overline{P}_i$ to $C_{n+j}$ ('F182)	6.2 ns	6.2 ns
$C_n$ to F	8.1 ns	—
$C_n$ to $C_{n+4}, OVR$	—	8.0 ns
<b>Total Delay</b>	<b>21.5 ns</b>	<b>21.4 ns</b>

Truth Table

FUNCTION	INPUTS						OUTPUTS					
	S <sub>0</sub>	S <sub>1</sub>	S <sub>2</sub>	C <sub>n</sub>	A <sub>n</sub>	B <sub>n</sub>	F <sub>0</sub>	F <sub>1</sub>	F <sub>2</sub>	F <sub>3</sub>	$\overline{G}$	$\overline{P}$
CLEAR	0	0	0	X	X	X	0	0	0	0	0	0
B MINUS A	1	0	0	0	0	0	1	1	1	1	1	0
				0	0	1	0	1	1	1	0	0
				0	1	0	0	0	0	0	1	1
				0	1	1	1	1	1	1	1	0
				1	0	0	0	0	0	0	1	0
				1	0	1	1	1	1	1	0	0
				1	1	0	1	0	0	0	1	1
A MINUS B	0	1	0	0	0	0	1	1	1	1	1	0
				0	0	1	0	0	0	0	1	1
				0	1	0	0	1	1	1	0	0
				0	1	1	1	1	1	1	1	0
				1	0	0	0	0	0	0	1	0
				1	0	1	1	0	0	0	1	1
				1	1	0	1	1	1	1	0	0
A PLUS B	1	1	0	0	0	0	0	0	0	0	1	1
				0	0	1	1	1	1	1	1	0
				0	1	0	1	1	1	1	1	0
				0	1	1	0	1	1	1	0	0
				1	0	0	1	0	0	0	1	1
				1	0	1	0	0	0	0	1	0
				1	1	0	0	0	0	0	1	0
A ⊕ B	0	0	1	X	0	0	0	0	0	0	0	0
				X	0	1	1	1	1	1	1	1
				X	1	0	1	1	1	1	1	0
				X	1	1	0	0	0	0	0	0
A + B	1	0	1	X	0	0	0	0	0	0	0	0
				X	0	1	1	1	1	1	1	1
				X	1	0	1	1	1	1	1	1
				X	1	1	1	1	1	1	1	0
AB	0	1	1	X	0	0	0	0	0	0	0	0
				X	0	1	0	0	0	0	1	1
				X	1	0	0	0	0	0	0	0
				X	1	1	1	1	1	1	1	0
PRESET	1	1	1	X	0	0	1	1	1	1	1	1
				X	0	1	1	1	1	1	1	1
				X	1	0	1	1	1	1	1	1
				X	1	1	1	1	1	1	1	0

1 = HIGH Voltage Level

0 = LOW Voltage Level

X = Immaterial

## DC Characteristics over Operating Temperature Range (unless otherwise specified)

Symbol	Parameter	54F/74F			Units	Conditions
		Min	Typ	Max		
I <sub>CC</sub>	Power Supply Current		59	89	mA	V <sub>CC</sub> = Max, S <sub>0</sub> - S <sub>3</sub> = Gnd; Other Inputs HIGH

## AC Characteristics: See Section 3 for waveforms and load configurations

Symbol	Parameter	54F/74F			54F		74F		Units	Fig. No.
		T <sub>A</sub> = +25°C, V <sub>CC</sub> = +5.0 V C <sub>L</sub> = 50 pF			T <sub>A</sub> , V <sub>CC</sub> = Mil C <sub>L</sub> = 50 pF		T <sub>A</sub> , V <sub>CC</sub> = Com C <sub>L</sub> = 50 pF			
		Min	Typ	Max	Min	Max	Min	Max		
t <sub>PLH</sub> t <sub>PHL</sub>	Propagation Delay C <sub>n</sub> to F <sub>i</sub>	2.5 2.5	8.1 5.7	10.5 8.0	2.5 2.5	15 11.5	2.5 2.5	11.5 9.0	ns	3-1 3-10
t <sub>PLH</sub> t <sub>PHL</sub>	Propagation Delay Any A or B to Any F	4.0 3.5	10.4 8.2	13.5 11	4.0 3.5	19 15.5	4.0 3.5	14.5 12	ns	3-1 3-10
t <sub>PLH</sub> t <sub>PHL</sub>	Propagation Delay S <sub>i</sub> to F <sub>i</sub>	4.5 4.0	8.3 8.2	11 11	4.5 4.0	15.5 15.5	4.5 4.0	12 12	ns	3-1 3-10
t <sub>PLH</sub> t <sub>PHL</sub>	Propagation Delay A <sub>i</sub> or B <sub>i</sub> to $\overline{G}$	3.5 4.0	6.4 6.8	9.0 10	3.5 4.0	12.5 14	3.5 4.0	10 11	ns	3-1 3-10
t <sub>PLH</sub> t <sub>PHL</sub>	Propagation Delay A <sub>i</sub> or B <sub>i</sub> to $\overline{P}$	4.0 3.5	7.2 6.5	10.5 9.5	4.0 3.5	15 13	4.0 3.5	11.5 10.5	ns	3-1 3-10
t <sub>PLH</sub> t <sub>PHL</sub>	Propagation Delay S <sub>i</sub> to $\overline{G}$ or $\overline{P}$	4.0 4.5	7.8 10.2	10.5 13.5	4.0 4.5	15 19	4.0 4.5	11.5 14.5	ns	3-1 3-10

■ Test limits in screened columns are preliminary.

# 54F/74F382

## 4-Bit Arithmetic Logic Unit

### Description

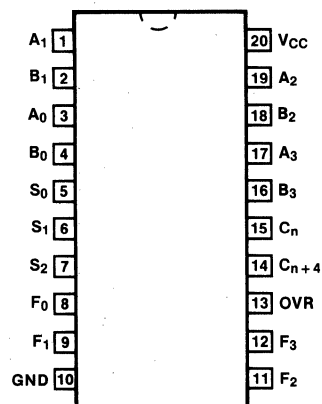
The 'F382 performs three arithmetic and three logic operations on two 4-bit words, A and B. Two additional Select input codes force the Function outputs LOW or HIGH. An Overflow output is provided for convenience in twos complement arithmetic. A Carry output is provided for ripple expansion. For high-speed expansion using a Carry Lookahead Generator, refer to the 'F381 data sheet.

- Performs Six Arithmetic and Logic Functions
- Selectable Low (Clear) and High (Preset) Functions
- Low Input Loading Minimizes Drive Requirements
- Carry Output for Ripple Expansion
- Overflow Output for Twos Complement Arithmetic

Ordering Code: See Section 6

Pkgs	Commercial Grade	Military Grade	Pkg Type
	$V_{CC} = +5.0 \text{ V} \pm 5\%$ , $T_A = 0^\circ \text{ C to } +70^\circ \text{ C}$	$V_{CC} = +5.0 \text{ V} \pm 10\%$ , $T_A = -55^\circ \text{ C to } +125^\circ \text{ C}$	
Plastic DIP (P)	74F382PC		9Z
Ceramic DIP (D)	74F382DC	54F382DM	4E
Flatpak (F)		54F382FM	4D

### Connection Diagram

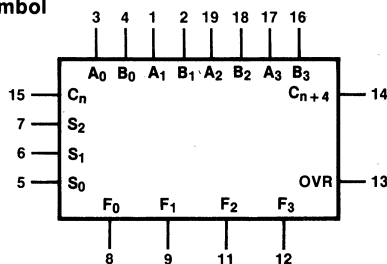


4

Input Loading/Fan-Out: See Section 3 for U.L. definitions

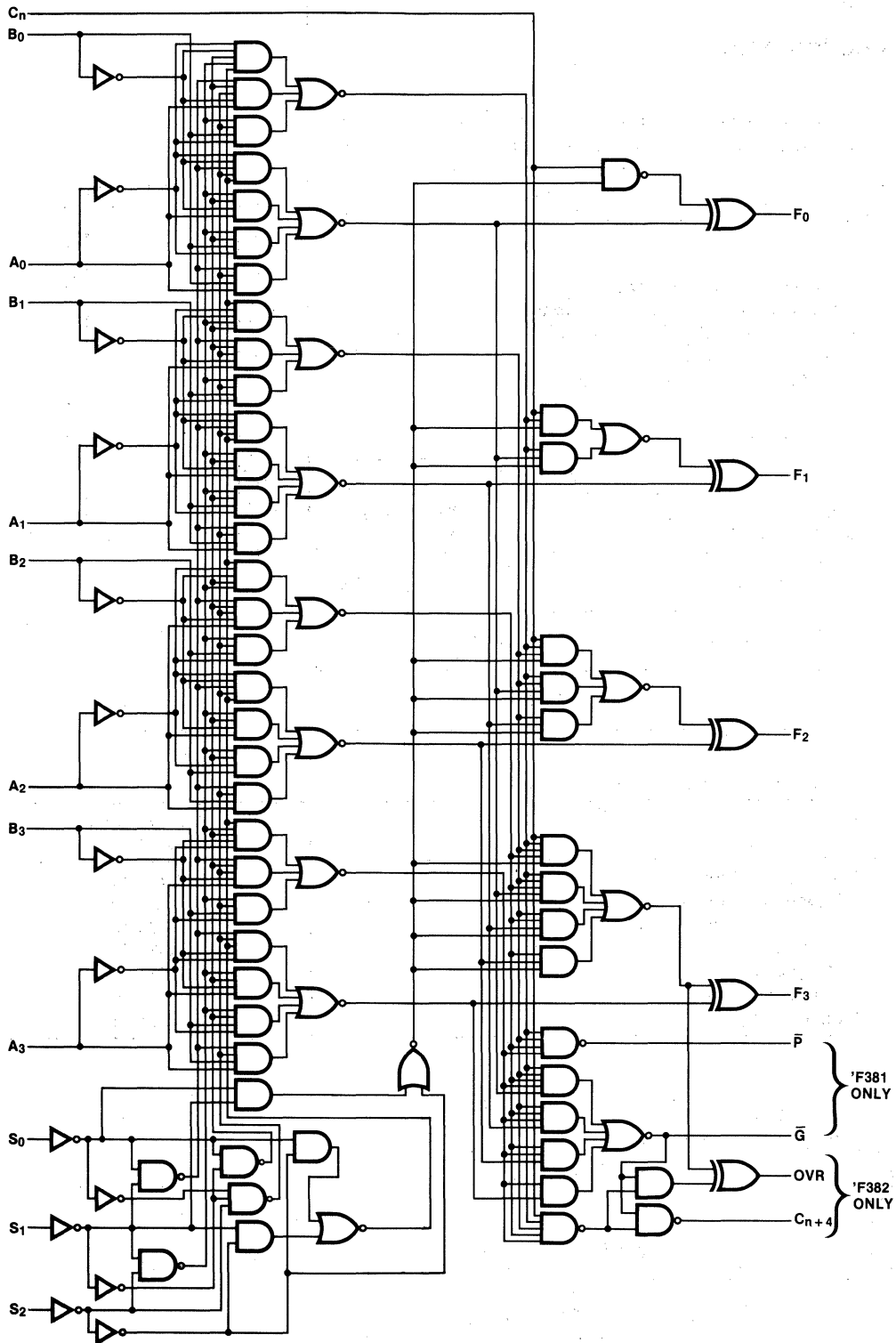
Pin Names	Description	54F/74F (U.L.) HIGH/LOW
A <sub>0</sub> - A <sub>3</sub>	A Operand Inputs	0.5/1.50
B <sub>0</sub> - B <sub>3</sub>	B Operand Inputs	0.5/1.50
S <sub>0</sub> - S <sub>2</sub>	Function Select Inputs	0.5/0.375
C <sub>n</sub>	Carry Input	0.5/1.875
C <sub>n</sub> + 4	Carry Output	25/12.5
OVR	Overflow Output	25/12.5
F <sub>0</sub> - F <sub>3</sub>	Function Outputs	25/12.5

### Logic Symbol



$V_{CC}$  = Pin 20  
GND = Pin 10

## Logic Diagram



**Functional Description**

Signals applied to the Select inputs  $S_0 - S_2$  determine the mode of operation, as indicated in the Function Select Table. An extensive listing of input and output levels is shown in the Truth Table. The circuit performs the arithmetic functions for either active-HIGH or active-LOW operands, with output levels in the same convention. In the Subtract operating modes, it is necessary to force a carry (HIGH for active-HIGH operands, LOW for active-LOW operands) into the  $C_n$  input of the least significant package. Ripple expansion is illustrated in *Figure a*. The Overflow output OVR is the Exclusive-OR of  $C_{n+3}$  and  $C_{n+4}$ ; a HIGH signal on OVR indicates overflow in twos complement operation. Typical delays for *Figure a* are given in *Figure b*.

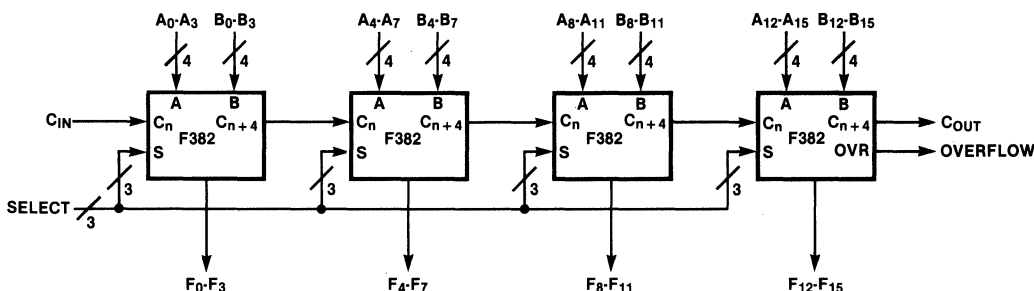
**Function Table**

SELECT			OPERATION
$S_0$	$S_1$	$S_2$	
L	L	L	Clear
H	L	L	B Minus A
L	H	L	A Minus B
H	H	L	A Plus B
L	L	H	$A \oplus B$
H	L	H	$A + B$
L	H	H	AB
H	H	H	Preset

H = HIGH Voltage Level    L = LOW Voltage Level

4

**Fig. a 16-Bit Ripple Carry ALU Expansion**



**Fig. b 16-Bit Delay Tabulation**

PATH SEGMENT	TOWARD F	OUTPUT $C_{n+4}$ , OVR
$A_i$ or $B_i$ to $C_{n+4}$	6.5 ns	6.5 ns
$C_n$ to $C_{n+4}$	6.3 ns	6.3 ns
$C_n$ to $C_{n+4}$	6.3 ns	6.3 ns
$C_n$ to F	8.1 ns	—
$C_n$ to $C_{n+4}$ , OVR	—	8.0 ns
Total Delay	27.2 ns	27.1 ns

Truth Table

FUNCTION	INPUTS						OUTPUTS						
	S <sub>0</sub>	S <sub>1</sub>	S <sub>2</sub>	C <sub>n</sub>	A <sub>n</sub>	B <sub>n</sub>	F <sub>0</sub>	F <sub>1</sub>	F <sub>2</sub>	F <sub>3</sub>	OVR	C <sub>n+4</sub>	
CLEAR	0	0	0	0	X	X	0	0	0	0	1	1	
				1	X	X	0	0	0	0	1	1	
B MINUS A	1	0	0	0	0	0	1	1	1	1	0	0	
				0	0	1	0	1	1	1	0	1	
				0	1	0	0	0	0	0	0	0	0
				0	1	1	1	1	1	1	1	0	0
				1	0	0	0	0	0	0	0	0	1
				1	0	1	1	1	1	1	1	0	1
				1	1	0	1	0	0	0	0	0	0
1	1	1	1	0	0	0	0	0	0	1			
A MINUS B	0	1	0	0	0	0	1	1	1	1	0	0	
				0	0	1	0	0	0	0	0	0	0
				0	1	0	0	1	1	1	1	0	1
				0	1	1	1	1	1	1	1	0	0
				1	0	0	0	0	0	0	0	0	1
				1	0	1	1	0	0	0	0	0	0
				1	1	0	1	1	1	1	1	0	1
1	1	1	1	0	0	0	0	0	0	1			
A PLUS B	1	1	0	0	0	0	0	0	0	0	0	0	
				0	0	1	1	1	1	1	0	0	
				0	1	0	1	1	1	1	0	0	
				0	1	1	0	1	1	1	0	1	
				1	0	0	1	0	0	0	0	0	0
				1	0	1	0	0	0	0	0	0	1
				1	1	0	0	0	0	0	0	0	1
1	1	1	1	1	1	1	1	0	1				
A ⊕ B	0	0	1	X	0	0	0	0	0	0	0	0	
				X	0	1	1	1	1	1	0	0	
				0	1	0	1	1	1	1	0	0	
				X	1	1	0	0	0	0	1	1	
				1	1	0	1	1	1	1	1	1	
A + B	1	0	1	X	0	0	0	0	0	0	0	0	
				X	0	1	1	1	1	1	0	0	
				X	1	0	1	1	1	1	0	0	
				0	1	1	1	1	1	1	0	0	
				1	1	1	1	1	1	1	1	1	
AB	0	1	1	X	0	0	0	0	0	0	1	1	
				X	0	1	0	0	0	0	0	0	
				X	1	0	0	0	0	0	1	1	
				0	1	1	1	1	1	1	0	0	
				1	1	1	1	1	1	1	1	1	
PRESET	1	1	1	X	0	0	1	1	1	1	0	0	
				X	0	1	1	1	1	1	0	0	
				X	1	0	1	1	1	1	0	0	
				0	1	1	1	1	1	1	0	0	
				1	1	1	1	1	1	1	1	1	

1 = HIGH Voltage Level 0 = LOW Voltage Level X = Immaterial

**DC Characteristics over Operating Temperature Range** (unless otherwise specified)

Symbol	Parameter	54F/74F			Units	Conditions
		Min	Typ	Max		
I <sub>CC</sub>	Power Supply Current		62	93	mA	V <sub>CC</sub> = Max; S <sub>0</sub> , C <sub>n</sub> = HIGH Other Inputs Gnd

**AC Characteristics:** See Section 3 for waveforms and load configurations

Symbol	Parameter	54F/74F			54F		74F		Units	Fig. No.
		T <sub>A</sub> = +25°C, V <sub>CC</sub> = +5.0 V C <sub>L</sub> = 50 pF			T <sub>A</sub> , V <sub>CC</sub> = Mil C <sub>L</sub> = 50 pF		T <sub>A</sub> , V <sub>CC</sub> = Com C <sub>L</sub> = 50 pF			
		Min	Typ	Max	Min	Max	Min	Max		
t <sub>PLH</sub> t <sub>PHL</sub>	Propagation Delay C <sub>n</sub> to F <sub>i</sub>	3.0 2.5	8.1 5.7	11.5 8.0			3.0 2.5	12.5 9.0	ns	3-1 3-10
t <sub>PLH</sub> t <sub>PHL</sub>	Propagation Delay Any A or B to Any F	4.0 3.5	10.4 8.2	13.5 11			4.0 3.5	14.5 12	ns	3-1 3-10
t <sub>PLH</sub> t <sub>PHL</sub>	Propagation Delay S <sub>i</sub> to F <sub>i</sub>	6.5 4.0	11 8.2	15 11			6.5 4.0	16 12	ns	3-1 3-10
t <sub>PLH</sub> t <sub>PHL</sub>	Propagation Delay A <sub>i</sub> or B <sub>i</sub> to C <sub>n+4</sub>	3.5 3.5	6.0 6.5	8.5 9.0			3.5 3.5	9.5 10.5	ns	3-1 3-10
t <sub>PLH</sub> t <sub>PHL</sub>	Propagation Delay S <sub>i</sub> to OVR or C <sub>n+4</sub>	7.0 5.0	12.5 9.0	16.5 12			7.0 5.0	17.5 13	ns	3-1 3-10
t <sub>PLH</sub> t <sub>PHL</sub>	Propagation Delay C <sub>n</sub> to C <sub>n+4</sub>	3.5 4.0	5.6 6.3	8.0 9.0			3.5 4.0	9.0 10	ns	3-1 3-10
t <sub>PLH</sub> t <sub>PHL</sub>	Propagation Delay C <sub>n</sub> to OVR	5.0 4.5	8.0 7.1	11 10			5.0 4.5	12 11	ns	3-1 3-10



## 54F/74F384

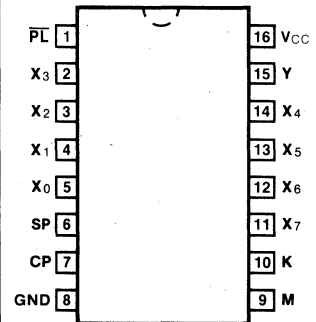
### 8-Bit Serial/Parallel Twos Complement Multiplier

#### Connection Diagram

#### Description

The 'F384 is an 8-bit by 1-bit sequential logic element that multiplies two numbers represented in twos complement notation. The device implements Booth's algorithm internally to produce a twos complement product that needs no subsequent correction. Parallel inputs accept and store an 8-bit multiplicand ( $X_0 - X_7$ ). The multiplier word is applied to the Y input in a serial bit stream, least significant bit first. The product is clocked out at the SP output, least significant bit first.

The K input is used for expansion to longer X words, using two or more 'F384 devices. The Mode Control (M) input is used to establish the most significant device. An asynchronous Parallel Load ( $\overline{PL}$ ) input clears the internal flip-flops to the start condition and enables the X latches to accept new multiplicand data.



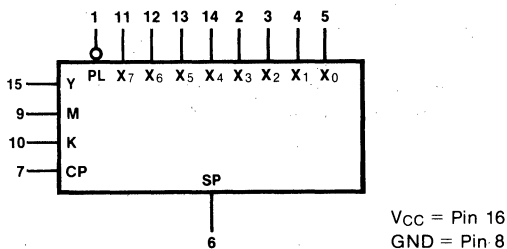
**Ordering Code:** See Section 6

Pkgs	Commercial Grade	Military Grade	Pkg Type
	$V_{CC} = +5.0\text{ V} \pm 5\%$ , $T_A = 0^\circ\text{ C to } +70^\circ\text{ C}$	$V_{CC} = +5.0\text{ V} \pm 10\%$ , $T_A = -55^\circ\text{ C to } +125^\circ\text{ C}$	
Plastic DIP (P)	74F384PC		9B
Ceramic DIP (D)	74F384DC	54F384DM	6B
Flatpak (F)		54F384FM	4L

**Input Loading/Fan-Out:** See Section 3 for U.L. definitions

Pin Names	Description	54F/74F (U.L.) HIGH/LOW
CP	Clock Pulse Input (Active Rising Edge)	0.5/0.375
K	Serial Expansion Input	0.5/0.375
M	Mode Control Input	0.5/0.375
$\overline{PL}$	Asynchronous Parallel Load Input (Active LOW)	0.5/0.750
$X_0 - X_7$	Multiplicand Data Inputs	0.5/0.375
Y	Serial Multiplier Input	0.5/0.375
SP	Serial $X \cdot Y$ Product Output	25/12.5

Logic Symbol

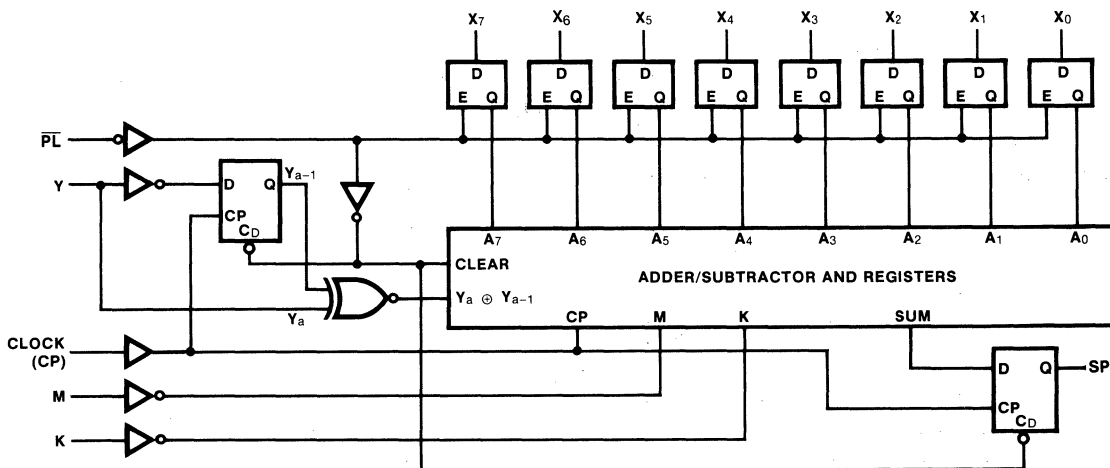


Function Table

INPUTS						INTERNAL	OUTPUT	FUNCTION
$\overline{PL}$	CP	K	M	$X_i$	Y	$Y_{a-1}$	SP	
		L	L					Most Significant Multiplier Device
		CS	H					Devices Cascaded in Multiplier String
L				OP		L	L	Load New Multiplicand and Clear Internal Sum and Carry Registers
H								Device Enabled
H	$\uparrow$				L	L	AR	Shift Sum Register
H	$\uparrow$				L	H	AR	Add Multiplicand to Sum Register and Shift
H	$\uparrow$				H	L	AR	Subtract Multiplicand from Sum Register and Shift
H	$\uparrow$				H	H	AR	Shift Sum Register

$\uparrow$  = LOW-to-HIGH transition  
 CS = Connected to SP output of high order device  
 OP =  $X_i$  latches open for new data ( $i = 0,7$ )  
 AR = Output as required per Booth's algorithm

Logic Diagram



### Functional Description

Referring to the Logic Diagram, the multiplicand ( $X_0 - X_7$ ) latches are enabled to receive new data when  $\overline{PL}$  is LOW. Data that meet the setup time requirements are latched and stored when  $\overline{PL}$  goes HIGH. The LOW signal on  $\overline{PL}$  also clears the  $Y_{a-1}$  flip-flop as well as the carry-save flip-flops and the partial product register in the arithmetic section. *Figure a* is a conceptual logic diagram of a typical cell in the arithmetic section, except for the first ( $X_7$ ) cell, in which  $K$  is the  $B_i$  input and  $M$  is incorporated into the carry logic. The cells use the carry-save technique to avoid the complexity and delays inherent in lookahead carry schemes for longer words.

*Figure b* is a timing diagram for an  $8 \times 8$  multiplication process. New multiplicand data enters the  $X$  latches during bit time  $T_0$ . It is assumed that  $\overline{PL}$  goes LOW shortly after the CP rising edge that marks the beginning of  $T_0$  and goes HIGH again shortly after the beginning of  $T_1$ . The LSB ( $Y_0$ ) of the multiplier is applied to the  $Y$  input during  $T_1$  and combines with  $X_0$  in the least significant cell to form the appropriate  $D$  input ( $X_0 Y_0$ ) to the sum flip-flop. This is clocked into the sum flip-flop by the CP rising edge at the beginning of  $T_2$  and this LSB ( $S_0$ ) of the product is available shortly thereafter at the SP output of the package. The next-least bit  $Y_1$  of the multiplier is also applied during  $T_2$ . The detailed logic design of the cell is such that during  $T_2$  the  $D$  input to the sum flip-flop of the least significant cell contains not only

$X_0 Y_1$  but also, thanks to storage in its carry flip-flop and in the sum flip-flop of the next-least cell, the  $X_1 Y_0$  product. Thus the term  $(X_1 Y_0 + X_0 Y_1)$  is formed at the  $D$  input of the least significant sum flip-flop during  $T_2$  and this next-least term  $S_1$  of the product is available at the SP output shortly after the CP rising edge at the beginning of  $T_3$ . Due to storage in the two preceding cells and in its own carry flip-flop, the  $D$  input to the least significant sum flip-flop during  $T_3$  will contain the products  $X_2 Y_0$  and  $X_1 Y_1$  as well as  $X_0 Y_2$ . During each succeeding bit time the SP output contains information formed one stage further upstream. For example, the SP output during  $T_9$  contains  $X_7 Y_0$ , which was actually formed during  $T_1$ .

The MSB  $Y_7$  (the sign bit  $Y_s$ ) of the multiplier is first applied to the  $Y$  input during  $T_8$  and must also be applied during bit times  $T_9$  through  $T_{16}$ . This extension of the sign bit is a necessary adjunct to the implementation of Booth's algorithm and is a built-in feature of the 'F322 Shift Register. *Figure c* shows the method of using two 'F384s to perform a  $12 \times n$  bit multiplication. Notice that the sign of  $X$  is effectively extended by connecting  $X_{11}$  to  $X_4 - X_7$  of the most significant package. Whereas the  $8 \times 8$  multiplication required 18 clock periods ( $m + n$  to form the product terms plus  $T_0$  to clear the multiplier plus  $T_{17}$  to recognize and store  $S_{15}$ ), the arrangement of *Figure c* requires  $12 + n$  bits to form the product terms plus the bit times to clear the multiplier and to recognize and store  $SP_{n+11}$ .

Fig. a Conceptual Carry Save Adder Cell

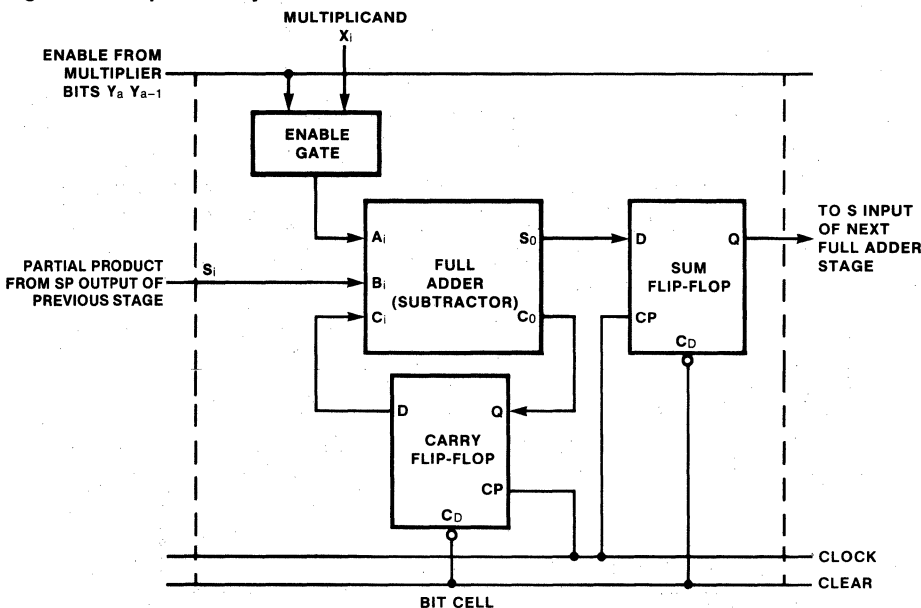
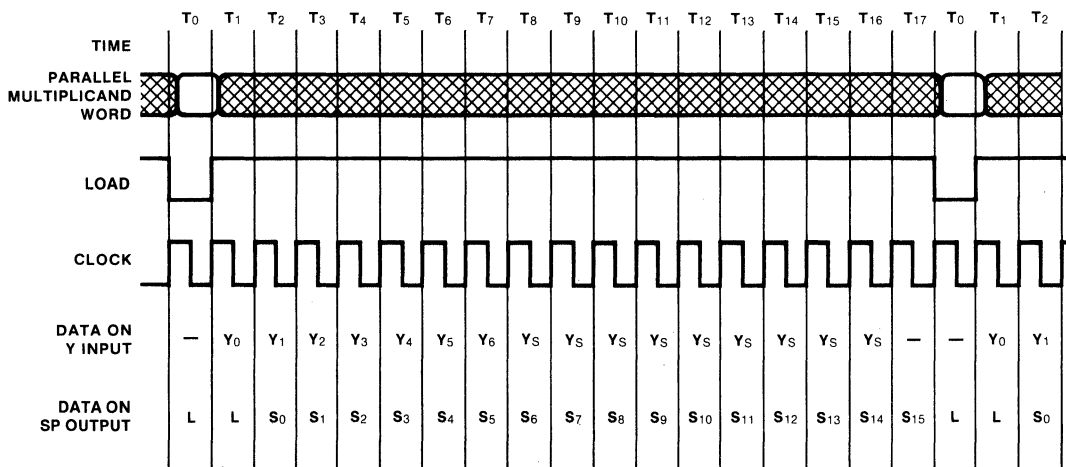
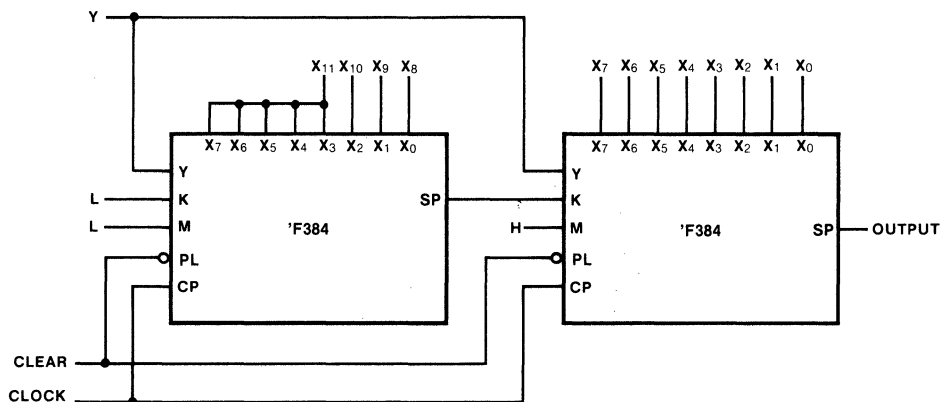


Fig. b Timing Diagram Showing 18 Clock Cycle Operation of 8 x 8 Multiplication



4

Fig. c 12-Bit by N-Bit Twos Complement Multiplier



**DC Characteristics over Operating Temperature Range** (unless otherwise specified)

Symbol	Parameter	54F/74F			Units	Conditions
		Min	Typ	Max		
I <sub>CC</sub>	Power Supply Current		67	108	mA	V <sub>CC</sub> = Max

**AC Characteristics:** See Section 3 for waveforms and load configurations

Symbol	Parameter	54F/74F			54F		74F		Units	Fig. No.
		T <sub>A</sub> = +25°C, V <sub>CC</sub> = +5.0 V, C <sub>L</sub> = 50 pF			T <sub>A</sub> , V <sub>CC</sub> = Mil, C <sub>L</sub> = 50 pF		T <sub>A</sub> , V <sub>CC</sub> = Com, C <sub>L</sub> = 50 pF			
		Min	Typ	Max	Min	Max	Min	Max		
f <sub>max</sub>	Maximum Clock Frequency	100	70					ns	3-1, 3-7	
t <sub>PLH</sub>	Propagation Delay	3.5	6.0	8.5				ns	3-1	
t <sub>PHL</sub>	CP to SP	3.5	6.0	8.5				ns	3-7	
t <sub>PHL</sub>	Propagation Delay PL to SP	4.0	7.0	10				ns	3-1 3-11	

**AC Operating Requirements:** See Section 3 for waveforms

Symbol	Parameter	54F/74F			54F		74F		Units	Fig. No.
		T <sub>A</sub> = +25°C, V <sub>CC</sub> = +5.0 V			T <sub>A</sub> , V <sub>CC</sub> = Mil		T <sub>A</sub> , V <sub>CC</sub> = Com			
		Min	Typ	Max	Min	Max	Min	Max		
t <sub>s</sub> (H) t <sub>s</sub> (L)	Setup Time, HIGH or LOW K to CP	8.0						ns	3-5	
t <sub>h</sub> (H) t <sub>h</sub> (L)	Hold Time, HIGH or LOW K to CP	0						ns	3-5	
t <sub>s</sub> (H) t <sub>s</sub> (L)	Setup Time, HIGH or LOW Y to CP	15						ns	3-5	
t <sub>h</sub> (H) t <sub>h</sub> (L)	Hold Time, HIGH or LOW Y to CP	0						ns	3-5	
t <sub>s</sub> (H) t <sub>s</sub> (L)	Setup Time, HIGH or LOW X <sub>n</sub> to $\overline{PL}$	10						ns	3-14	
t <sub>h</sub> (H) t <sub>h</sub> (L)	Hold Time, HIGH or LOW X <sub>n</sub> to $\overline{PL}$	0						ns	3-14	
t <sub>w</sub> (H) t <sub>w</sub> (L)	CP Width, HIGH or LOW	7.0						ns	3-7	
t <sub>w</sub> (L)	$\overline{PL}$ Width LOW	5.0						ns	3-11	
t <sub>rec</sub>	Recovery Time PL to CP	7.0						ns	3-11	

■ Test limits in screened columns are preliminary.

# 54F/74F385

## Quad Serial Adder/Subtractor

### Description

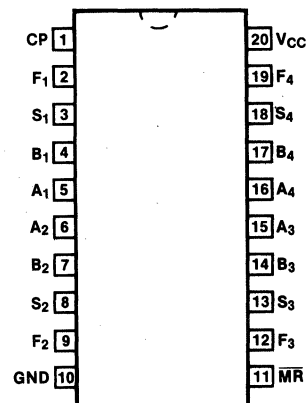
The 'F385 contains four serial adder/subtractors with common clock and clear inputs, but independent operand and mode select inputs. Each adder/subtractor contains a sum flip-flop and a carry-save flip-flop for synchronous operations. Each circuit performs either A plus B or A minus B in two's complement notation, but can also be used for magnitude-only or ones complement operation. The 'F385 is designed for use with the 'F384 and 'F784 serial multipliers in implementing digital filters or butterfly networks in fast Fourier transforms.

- Four Independent Adder/Subtractors
- Two's Complement Arithmetic
- Synchronous Operation
- Common Clear and Clock
- Ones Complement or Magnitude-only Capability

**Ordering Code:** See Section 6

Pkgs	Commercial Grade	Military Grade	Pkg Type
	$V_{CC} = +5.0\text{ V} \pm 5\%$ , $T_A = 0^\circ\text{ C to } +70^\circ\text{ C}$	$V_{CC} = +5.0\text{ V} \pm 10\%$ , $T_A = -55^\circ\text{ C to } +125^\circ\text{ C}$	
Plastic DIP (P)	74F385PC		9Z
Ceramic DIP (D)	74F385DC	54F385DM	4E
Flatpak (F)		54F385FM	4D

### Connection Diagram

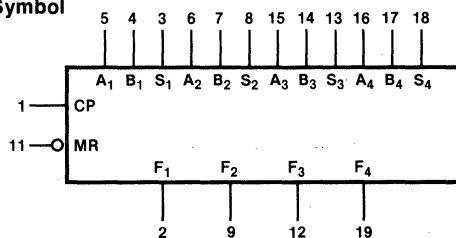


4

**Input Loading/Fan-Out:** See Section 3 for U.L. definitions

Pin Names	Description	54F/74F (U.L.) HIGH/LOW
A <sub>1</sub> - A <sub>4</sub>	A Operand Inputs	0.5/0.375
B <sub>1</sub> - B <sub>4</sub>	B Operand Inputs	0.5/0.375
S <sub>1</sub> - S <sub>4</sub>	Function Select Inputs	0.5/0.375
CP	Clock Pulse Input (Active Rising Edge)	0.5/0.375
MR	Asynchronous Master Reset Input (Active LOW)	0.5/0.375
F <sub>1</sub> - F <sub>4</sub>	Sum or Difference Outputs	25/12.5

### Logic Symbol



$V_{CC}$  = Pin 20  
GND = Pin 10

## Functional Description

Each adder contains two edge-triggered flip-flops to store the sum and carry, as shown in the Logic Diagram. Flip-flop state changes occur on the rising edge of the Clock Pulse (CP) input signal. The Select (S) input should be LOW for the Add (A plus B) mode and HIGH for the Subtract (A minus B) mode. A LOW signal on the asynchronous Master Reset ( $\overline{MR}$ ) input clears the sum flip-flop and resets the carry flip-flop to zero in the Add mode or presets it to one in the Subtract mode.

In the Subtract mode, the B operand is internally complemented. Presetting the carry flip-flop to one completes the two's complement transformation by adding one to "A plus  $\overline{B}$ " during the first (LSB) operation after  $\overline{MR}$  is released. For ones complement subtraction, the carry flip-flop can be set to zero by making S LOW during the reset, then making S HIGH after the reset but before the next clock.

## Truth Table

INPUTS*				INTERNAL CARRY		OUTPUT*	FUNCTION
$\overline{MR}$	S	A	B	C	C <sub>1</sub>	F	
L	L	X	X	L	L	L	Clear
L	H	X	X	H	H	L	
H	L	L	L	L	L	L	Add
H	L	L	L	H	L	H	
H	L	L	H	L	L	H	
H	L	L	H	H	H	L	
H	L	H	L	L	L	H	
H	L	H	L	H	H	L	
H	L	H	H	L	H	L	
H	L	H	H	H	H	H	
H	H	L	L	L	L	H	Subtract
H	H	L	L	H	H	L	
H	H	L	H	L	L	L	
H	H	L	H	H	L	H	
H	H	H	L	L	H	L	
H	H	H	L	H	H	H	
H	H	H	H	L	L	H	
H	H	H	H	H	H	L	

H = HIGH Voltage Level

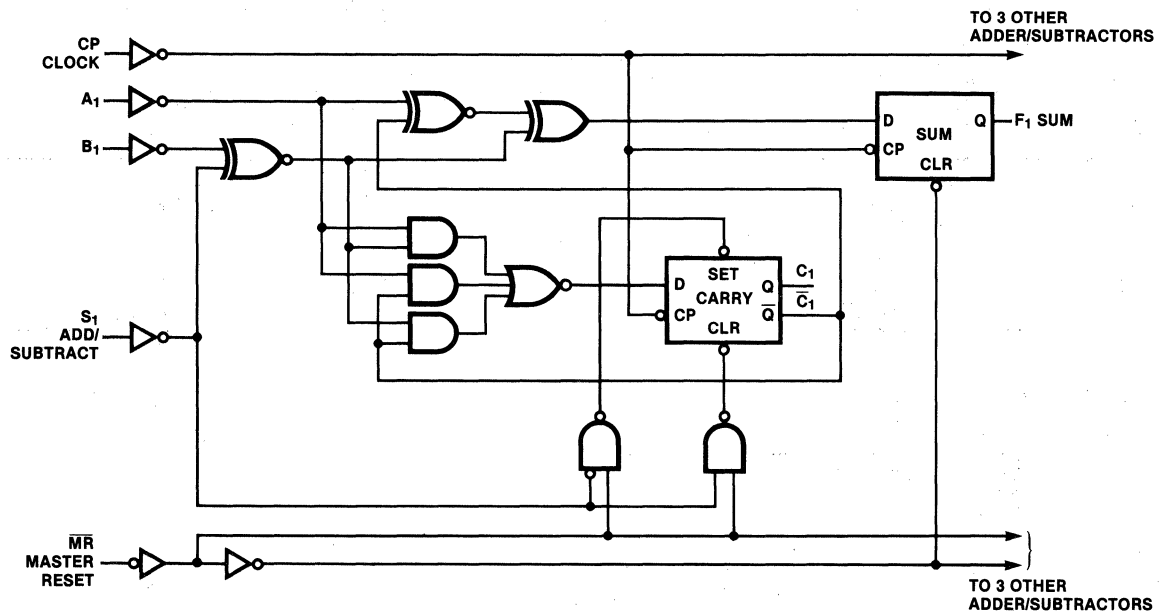
L = LOW Voltage Level

X = Immaterial

\* = Inputs before CP transition, output after C

C<sub>1</sub> = Carry flip-flop state before (C) and after (C<sub>1</sub>) clock transition

## Logic Diagram (one Adder/Subtractor shown)



**DC Characteristics over Operating Temperature Range** (unless otherwise specified)

Symbol	Parameter	54F/74F			Units	Conditions
		Min	Typ	Max		
I <sub>CC</sub>	Power Supply Current		68	104	mA	V <sub>CC</sub> = Max

**AC Characteristics:** See Section 3 for waveforms and load configurations

Symbol	Parameter	54F/74F			54F		74F		Units	Fig. No.
		T <sub>A</sub> = +25°C, V <sub>CC</sub> = +5.0 V C <sub>L</sub> = 50 pF			T <sub>A</sub> , V <sub>CC</sub> = Mil C <sub>L</sub> = 50 pF		T <sub>A</sub> , V <sub>CC</sub> = Com C <sub>L</sub> = 50 pF			
		Min	Typ	Max	Min	Max	Min	Max		
f <sub>max</sub>	Maximum Clock Frequency	80	100					MHz	3-1, 3-7	
t <sub>PLH</sub>	Propagation Delay CP to F <sub>n</sub>	3.0	6.0	8.5				ns	3-1 3-7	
t <sub>PHL</sub>	Propagation Delay MR to F <sub>n</sub>	4.0	7.0	10				ns	3-1 3-11	

**AC Operating Requirements:** See Section 3 for waveforms

Symbol	Parameter	54F/74F			54F		74F		Units	Fig. No.
		T <sub>A</sub> = +25°C, V <sub>CC</sub> = +5.0 V			T <sub>A</sub> , V <sub>CC</sub> = Mil		T <sub>A</sub> , V <sub>CC</sub> = Com			
		Min	Typ	Max	Min	Max	Min	Max		
t <sub>s</sub> (H) t <sub>s</sub> (L)	Setup Time, HIGH or LOW A <sub>n</sub> to CP	12						ns	3-5	
t <sub>h</sub> (H) t <sub>h</sub> (L)	Hold Time, HIGH or LOW A <sub>n</sub> to CP	0								
t <sub>s</sub> (H) t <sub>s</sub> (L)	Setup Time, HIGH or LOW B <sub>n</sub> or S <sub>n</sub> to CP	12						ns	3-5	
t <sub>h</sub> (H) t <sub>h</sub> (L)	Hold Time, HIGH or LOW B <sub>n</sub> or S <sub>n</sub> to CP	0								
t <sub>w</sub> (H) t <sub>w</sub> (L)	CP Pulse Width, HIGH or LOW	6.0						ns	3-7	
t <sub>w</sub> (L)	$\overline{\text{MR}}$ Width LOW	6.0						ns	3-11	
t <sub>rec</sub>	Recovery Time MR to CP	5.0						ns	3-11	

■ Test limits in screened columns are preliminary.



# 54F/74F398 • 54F/74F399

## Quad 2-Port Register

### Description

The 'F398 and 'F399 are the logical equivalent of a quad 2-input multiplexer feeding into four edge-triggered flip-flops. A common Select input determines which of the two 4-bit words is accepted. The selected data enters the flip-flops on the rising edge of the clock. The 'F399 is the 16-pin version of the 'F398, with only the Q outputs of the flip-flops available.

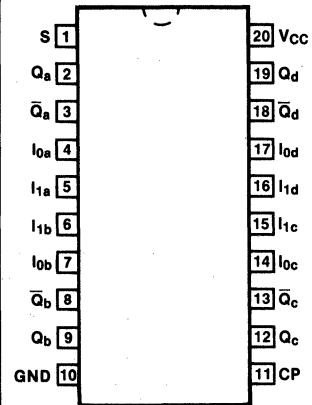
- Select Inputs from Two Data Sources
- Fully Positive Edge-triggered Operation
- Both True and Complement Outputs — 'F398

Ordering Code: See Section 6

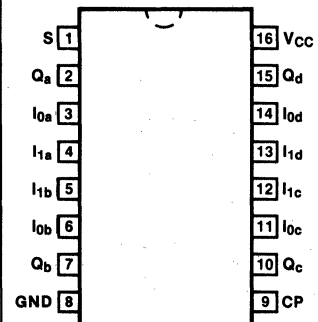
Pkgs	Commercial Grade	Military Grade	Pkg Type
	V <sub>CC</sub> = +5.0 V ±5%, T <sub>A</sub> = 0°C to +70°C	V <sub>CC</sub> = +5.0 V ±10%, T <sub>A</sub> = -55°C to +125°C	
Plastic DIP (P)	74F398PC 74F399PC		9Z 9B
Ceramic DIP (D)	74F398DC 74F399DC	54F398DM 54F399DM	4E 6B
Flatpak (F)		54F398FM 54F399FM	4D

### Connection Diagrams

'F398



'F399

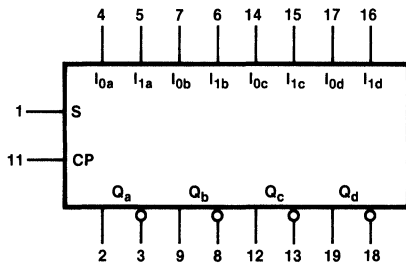


Input Loading/Fan-Out: See Section 3 for U.L. definitions

Pin Names	Description	54F/74F (U.L.) HIGH/LOW
S	Common Select Input	0.5/0.375
CP	Clock Pulse Input (Active Rising Edge)	0.5/0.375
I <sub>0a</sub> - I <sub>0d</sub>	Data Inputs from Source 0	0.5/0.375
I <sub>1a</sub> - I <sub>1d</sub>	Data Inputs from Source 1	0.5/0.375
Q <sub>a</sub> - Q <sub>d</sub>	Register True Outputs	25/12.5
Q <sub>a</sub> -Q <sub>d</sub>	Register Complementary Outputs ('F398)	25/12.5

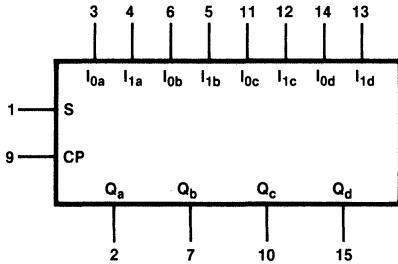
**Logic Symbols**

**'F398**



Vcc = Pin 20  
GND = Pin 10

**'F399**



Vcc = Pin 16  
GND = Pin 8

**Functional Description**

The 'F398 and 'F399 are high-speed quad 2-port registers. They select four bits of data from either of two sources (Ports) under control of a common Select input (S). The selected data is transferred to a 4-bit output register synchronous with the LOW-to-HIGH transition of the Clock input (CP). The 4-bit D-type output register is fully edge-triggered. The Data inputs (I<sub>0x</sub>, I<sub>1x</sub>) and Select input (S) must be stable only a setup time prior to and hold time after the LOW-to-HIGH transition of the Clock input for predictable operation. The 'F398 has both Q and  $\bar{Q}$  outputs.

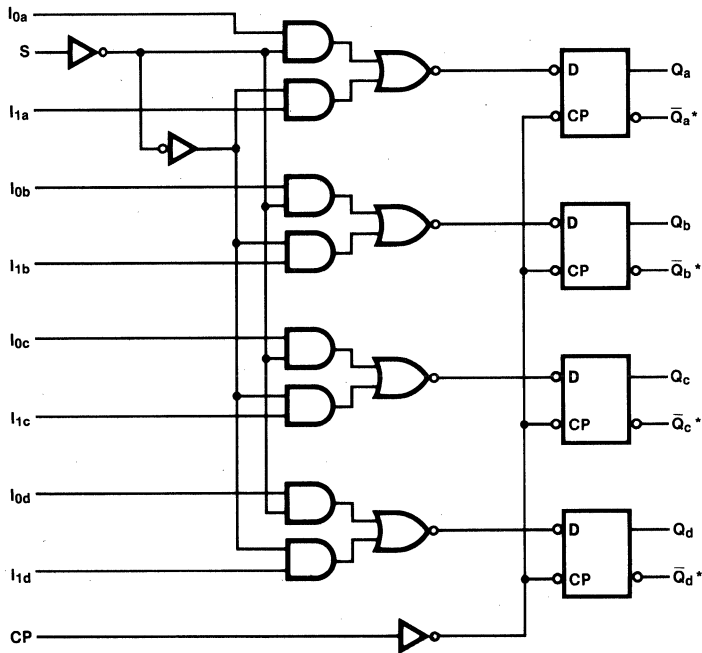
**Function Table**

INPUTS			OUTPUTS	
S	I <sub>0</sub>	I <sub>1</sub>	Q	$\bar{Q}$ *
l	l	X	L	H
l	h	X	H	L
h	X	l	L	H
h	X	h	H	L

\* 'F398 only

- l = LOW Voltage Level one setup time prior to the LOW-to-HIGH clock transition
- h = HIGH Voltage Level one setup time prior to the LOW-to-HIGH clock transition
- L = LOW Voltage Level
- H = HIGH Voltage Level
- X = Immaterial

Logic Diagram



\* 'F398 only

DC Characteristics over Operating Temperature Range (unless otherwise specified)

Symbol	Parameter	54F/74F			Units	Conditions
		Min	Typ	Max		
I <sub>CC</sub>	Power Supply Current	'F398	25	38	mA	V <sub>CC</sub> = Max, V <sub>IN</sub> = GND CP =
		'F399	22	34		

**AC Characteristics:** See Section 3 for waveforms and load configurations

Symbol	Parameter	54F/74F			54F		74F		Units	Fig. No.
		T <sub>A</sub> = +25°C, V <sub>CC</sub> = +5.0 V C <sub>L</sub> = 50 pF			T <sub>A</sub> , V <sub>CC</sub> = Mil C <sub>L</sub> = 50 pF		T <sub>A</sub> , V <sub>CC</sub> = Com C <sub>L</sub> = 50 pF			
		Min	Typ	Max	Min	Max	Min	Max		
f <sub>max</sub>	Input Clock Frequency	100	140			100		MHz	3-1, 3-7	
t <sub>PLH</sub>	Propagation Delay	3.5	6.0	8.0		3.5	9.0	ns	3-1	
t <sub>PHL</sub>	CP to Q or $\bar{Q}$	5.0	8.5	11		5.0	12		3-7	

**AC Operating Requirements:** See Section 3 for waveforms

Symbol	Parameter	54F/74F			54F		74F		Units	Fig. No.
		T <sub>A</sub> = +25°C, V <sub>CC</sub> = +5.0 V			T <sub>A</sub> , V <sub>CC</sub> = Mil		T <sub>A</sub> , V <sub>CC</sub> = Com			
		Min	Typ	Max	Min	Max	Min	Max		
t <sub>s</sub> (H)	Setup Time, HIGH or LOW	4.0				4.0		ns	3-1 3-5	
t <sub>s</sub> (L)	I <sub>n</sub> to CP	4.0				4.0				
t <sub>h</sub> (H)	Hold Time, HIGH or LOW	1.0				1.0		ns	3-5	
t <sub>h</sub> (L)	I <sub>n</sub> to CP	1.0				1.0				
t <sub>s</sub> (H)	Setup Time, HIGH or LOW	7.5				8.5		ns	3-5	
t <sub>s</sub> (L)	S to CP	7.5				8.5				
t <sub>h</sub> (H)	Hold Time, HIGH or LOW	0				0		ns	3-5	
t <sub>h</sub> (L)	S to CP	0				0				
t <sub>w</sub> (H)	Clock Pulse Width, HIGH or LOW	6.0				6.0		ns	3-7	
t <sub>w</sub> (L)		6.0				6.0				

# 54F/74F521

## 8-Bit Identity Comparator

### Connection Diagram

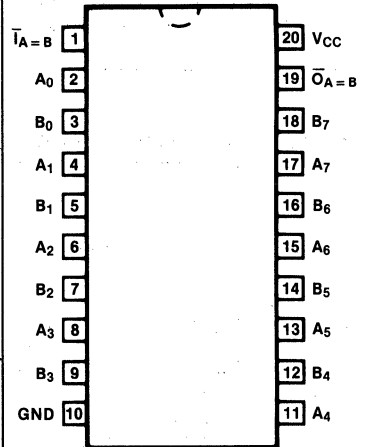
#### Description

The 'F521 is an expandable 8-bit comparator. It compares two words of up to eight bits each and provides a LOW output when the two words match bit for bit. The expansion input  $\overline{I}_{A=B}$  also serves as an active-LOW enable input.

- Compares Two 8-Bit Words in 6.5 ns Typ
- Expandable to Any Word Length
- 20-Pin Package

Ordering Code: See Section 6

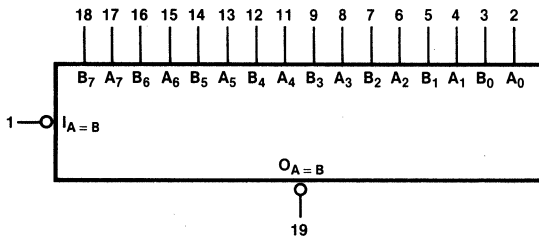
Pkgs	Commercial Grade	Military Grade	Pkg Type
	$V_{CC} = +5.0\text{ V} \pm 5\%$ , $T_A = 0^\circ\text{ C To } +70^\circ\text{ C}$	$V_{CC} = +5.0\text{ V} \pm 10\%$ , $T_A = -55^\circ\text{ C to } +125^\circ\text{ C}$	
Plastic DIP (P)	74F521PC		9Z
Ceramic DIP (D)	74F521DC	54F521DM	4E
Flatpak (F)		54F521FM	4D



Input Loading/Fan-Out: See Section 3 for U.L. definitions

Pin Names	Description	54F/74F (U.L.) HIGH/LOW
A <sub>0</sub> - A <sub>7</sub>	Word A Inputs	0.5/0.375
B <sub>0</sub> - B <sub>7</sub>	Word B Inputs	0.5/0.375
$\overline{I}_{A=B}$	Expansion or Enable Input (Active LOW)	0.5/0.375
$\overline{O}_{A=B}$	Identity Output (Active LOW)	25/12.5

#### Logic Symbol



Vcc = Pin 20  
GND = Pin 10

## Truth Table

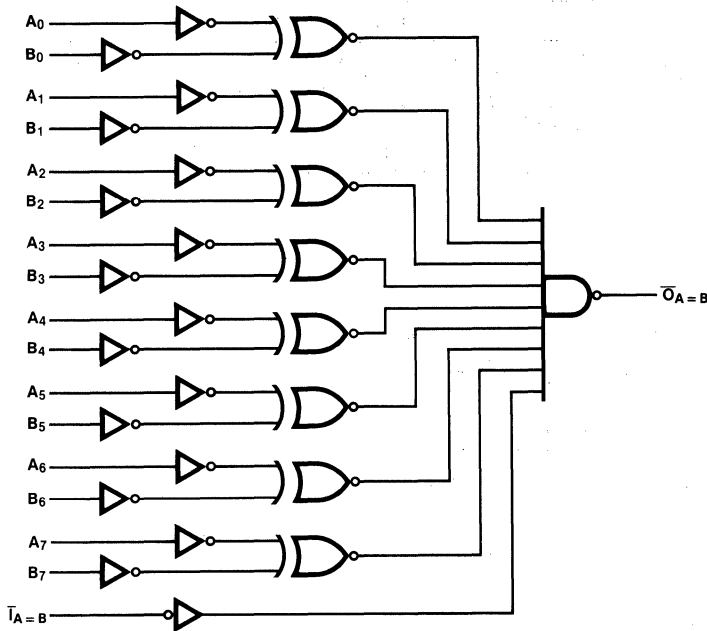
Inputs		Output
$\overline{A} = B$	A, B	$\overline{O}A = B$
L	$A = B^*$	L
L	$A \neq B$	H
H	$A = B^*$	H
H	$A \neq B$	H

H = HIGH Voltage Level

L = LOW Voltage Level

\* $A_0 = B_0, A_1 = B_1, A_2 = B_2, \text{ etc.}$

## Logic Diagram



Please note that this diagram is provided only for the understanding of logic operations and should not be used to estimate propagation delays.

## DC Characteristics over Operating Temperature Range (unless otherwise specified)

Symbol	Parameter	54F/74F			Units	Conditions
		Min	Typ	Max		
ICCH ICCL	Power Supply Current		24 15.5	36 23	mA	$V_{CC} = \text{Max}, I_A = B = \text{Gnd}$

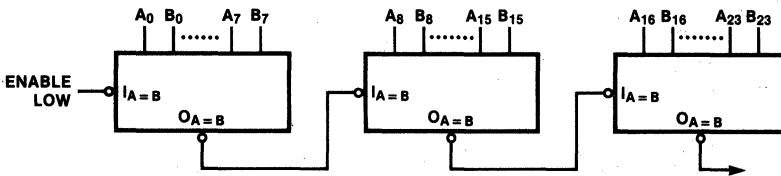
## AC Characteristics: See Section 3 for waveforms and load configurations

Symbol	Parameter	54F/74F			54F		74F		Units	Fig. No.
		$T_A = +25^\circ\text{C}, V_{CC} = +5.0\text{V}, C_L = 50\text{pF}$			$T_A, V_{CC} = \text{Mil}, C_L = 50\text{pF}$		$T_A, V_{CC} = \text{Com}, C_L = 50\text{pF}$			
		Min	Typ	Max	Min	Max	Min	Max		
tPLH tPHL	Propagation Delay $A_n$ or $B_n$ to $\overline{O_A = B}$	3.5 4.0	6.5 6.5	9.5 9.0	3.5 4.0	15 12	3.5 4.0	11 10.5	ns	3-1 3-10
tPLH tPHL	Propagation Delay $\overline{I_A = B}$ to $\overline{O_A = B}$	3.0 3.5	4.5 5.0	6.5 7.0	3.0 3.5	8.5 9.0	3.0 3.5	7.5 8.0	ns	3-1 3-10

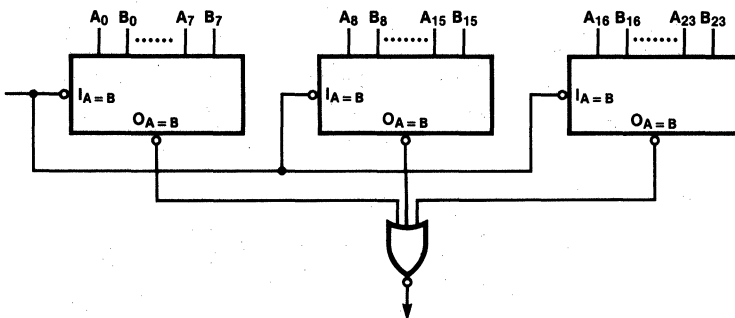
■ Test limits in screened columns are preliminary.

## Applications

### Ripple Expansion



### Parallel Expansion



# 54F/74F524

## 8-Bit Registered Comparator

### Description

The 'F524 is an 8-bit bidirectional register with parallel input and output plus serial input and output progressing from LSB to MSB. All data inputs, serial and parallel, are loaded by the rising edge of the input clock. The device functions are controlled by two control lines ( $S_0$ ,  $S_1$ ) to execute shift, load, hold and read out.

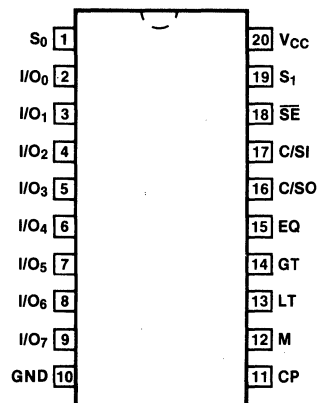
An 8-bit comparator examines the data stored in the registers and on the data bus. Three true-HIGH, open-collector outputs representing 'register equal to bus', 'register greater than bus' and 'register less than bus' are provided. These outputs can be disabled to the OFF state by the use of Status Enable ( $\overline{SE}$ ). A mode control has also been provided to allow twos complement as well as magnitude compare. Linking inputs are provided for expansion to longer words.

- 8-Bit Bidirectional Register with Bus Oriented Input-Output
- Independent Serial Input-Output to Register
- Register Bus Comparator with 'Equal to', 'Greater than' and 'Less than' Outputs
- Cascadable in Groups of Eight Bits
- Open-collector Comparator Outputs for AND-Wired Expansion
- Twos Complement or Magnitude Compare

Ordering Code: See Section 6

Pkgs	Commercial Grade	Military Grade	Pkg Type
	$V_{CC} = +5.0 \text{ V} \pm 5\%$ , $T_A = 0^\circ \text{ C to } +70^\circ \text{ C}$	$V_{CC} = +5.0 \text{ V} \pm 10\%$ , $T_A = -55^\circ \text{ C to } +125^\circ \text{ C}$	
Plastic DIP (P)	74F524PC		9Z
Ceramic DIP (D)	74F524DC	54F524DM	4E
Flatpak (F)		54F524FM	4D

### Connection Diagram



4

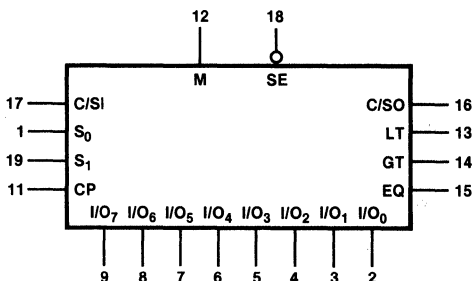
Input Loading/Fan-Out: See Section 3 for U.L. definitions

Pin Names	Description	54F/74F (U.L.) HIGH/LOW
$S_0$ , $S_1$	Mode Select Inputs	0.5/0.375
C/SI	Status Priority or Serial Data Input	0.5/0.375
CP	Clock Pulse Input (Active Rising Edge)	0.5/0.375
$\overline{SE}$	Status Enable Input (Active LOW)	0.5/0.375
M	Compare Mode Select Input	0.5/0.375
$I/O_0 - I/O_7$	Parallel Data Inputs or 3-State Parallel Data Outputs	1.25/0.375 25/12.5
C/SO	Status Priority or Serial Data Output	25/12.5
LT	Register Less Than Bus Output	OC*/12.5
EQ	Register Equal Bus Output	OC*/12.5
GT	Register Greater Than Bus Output	OC*/12.5

\*OC = Open Collector



Logic Symbol



V<sub>CC</sub> = Pin 20  
GND = Pin 10

Functional Description

The 'F524 contains eight D-type flip-flops connected as a shift register with provision for either parallel or serial loading. Parallel data may be read from or loaded into the registers via the data bus I/O<sub>0</sub>-I/O<sub>7</sub>. Serial data is entered from the C/SI input and may be shifted into the register and out through the C/SO output. Both parallel and serial data entry occur on the rising edge of the input clock (CP). The operation of the shift register is controlled by two signals S<sub>0</sub> and S<sub>1</sub> according to the Select Truth Table. The 3-State parallel output buffers are enabled only in the Read mode.

Select Truth Table

S <sub>0</sub>	S <sub>1</sub>	OPERATION
L	L	HOLD — Retains data in shift register
L	H	READ — Read contents in register onto data bus
H	L	SHIFT — Allows serial shifting on next rising clock edge
H	H	LOAD — Load data on bus into register

H = HIGH Voltage Level  
L = LOW Voltage Level

One port of an 8-bit comparator is attached to the data bus while the other port is tied to the outputs of the internal register. Three active-OFF, open-collector outputs indicate whether the contents held in the shift register are 'greater than', (GT), 'less than' (LT), or 'equal to' (EQ) the data on the input bus. A HIGH signal on the Status Enable ( $\overline{SE}$ ) input disables these outputs to the OFF state. A mode control input (M) allows selection between a straight-forward magnitude compare or a comparison between twos complement numbers.

Number Representation Select Table

M	OPERATION
L	Magnitude compare
H	Twos complement compare

H = HIGH Voltage Level  
L = LOW Voltage Level

For 'greater than' or 'less than' detection, the C/SI input must be held HIGH, as indicated in the Status Truth Table. The internal logic is arranged such that a LOW signal on the C/SI input disables the 'greater than' and 'less than' outputs. The C/SO output will be forced HIGH if the 'equal to' status condition exists, otherwise C/SO will be held LOW. These facilities enable the 'F524 to be cascaded for word length greater than eight bits.

Status Truth Table (Hold Mode)

INPUTS			OUTPUTS			
SE	C/SI	Data Comparison	EQ	GT	LT	C/SO
H	X	X	H	H	H	①
L	L	O <sub>A</sub> - O <sub>H</sub> > I/O <sub>0</sub> - I/O <sub>7</sub>	L	H	H	L
L	L	O <sub>A</sub> - O <sub>H</sub> = I/O <sub>0</sub> - I/O <sub>7</sub>	H	H	H	H
L	L	O <sub>A</sub> - O <sub>H</sub> < I/O <sub>0</sub> - I/O <sub>7</sub>	L	H	H	L
L	H	O <sub>A</sub> - O <sub>H</sub> > I/O <sub>0</sub> - I/O <sub>7</sub>	L	H	L	L
L	H	O <sub>A</sub> - O <sub>H</sub> = I/O <sub>0</sub> - I/O <sub>7</sub>	H	L	L	H
L	H	O <sub>A</sub> - O <sub>H</sub> < I/O <sub>0</sub> - I/O <sub>7</sub>	L	L	H	L

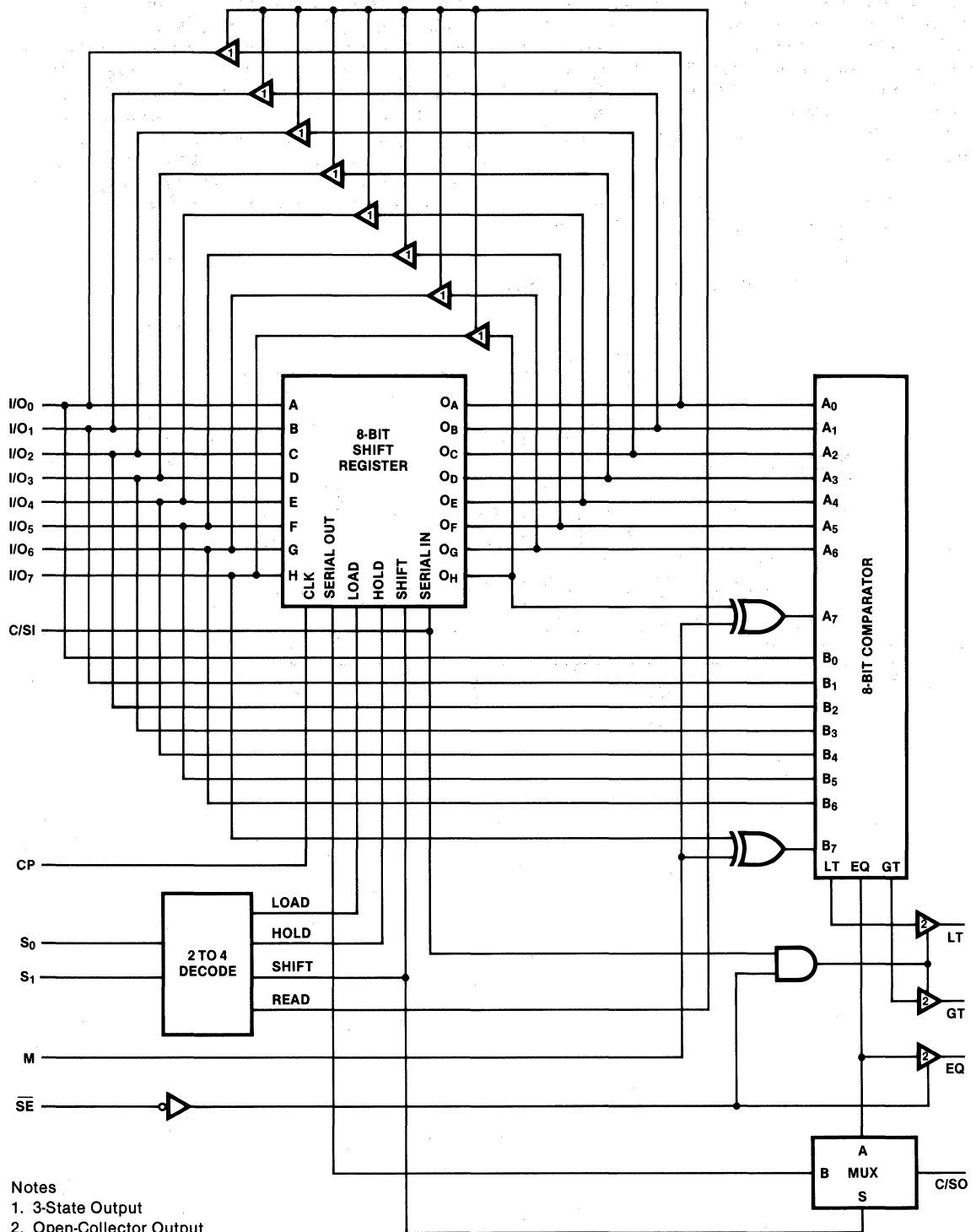
① = HIGH if data are equal, otherwise LOW  
H = HIGH Voltage Level  
L = LOW Voltage Level  
X = Immaterial

Word length expansion (in groups of eight bits) can be achieved by connecting the C/SO output of the more significant byte to the C/SI input of the next less significant byte and also to its own  $\overline{SE}$  input (see Figure a). The C/SI input of the most significant device is held HIGH while the  $\overline{SE}$  input of the least significant device is held LOW. The corresponding status outputs are AND-wired together. In the case of twos complement number compare, only the Mode input to the most significant device should be HIGH. The Mode inputs to all other cascaded devices are held LOW.

Suppose that an inequality condition is detected in the most significant device. Assuming that the byte stored in the register is greater than the byte on the



Functional Block Diagram



- Notes  
 1. 3-State Output  
 2. Open-Collector Output

**DC Characteristics over Operating Temperature Range** (unless otherwise specified)

Symbol	Parameter	54F/74F			Units	Conditions
		Min	Typ	Max		
I <sub>IH</sub>	Input HIGH Current Breakdown Test, I/O <sub>0</sub> - I/O <sub>7</sub>			1.0	mA	V <sub>CC</sub> = Max, V <sub>IN</sub> = 5.5 V
I <sub>OH</sub>	Output HIGH Current GT, EQ, LT			-100	μA	V <sub>CC</sub> = Min, V <sub>OUT</sub> = 4.5 V
I <sub>IH</sub> + I <sub>ozH</sub>	3-State Output OFF Current HIGH, I/O <sub>0</sub> - I/O <sub>7</sub>			70	μA	V <sub>CC</sub> = Max, V <sub>OUT</sub> = 2.4 V
I <sub>IL</sub> + I <sub>ozL</sub>	3-State Output OFF Current LOW, I/O <sub>0</sub> - I/O <sub>7</sub>			600	μA	V <sub>CC</sub> = Max, V <sub>IN</sub> = 0.5 V
I <sub>CC</sub>	Power Supply Current		128	180	mA	S <sub>0</sub> , S <sub>1</sub> , $\overline{SE}$ , C/SI = 4.5 V CP, I/O <sub>0</sub> - I/O <sub>7</sub> , Register = LOW

4

**AC Characteristics:** See Section 3 for waveforms and load configurations

Symbol	Parameter	54F/74F			54F		74F		Units	Fig. No.
		T <sub>A</sub> = +25° C, V <sub>CC</sub> = +5.0 V C <sub>L</sub> = 50 pF			T <sub>A</sub> , V <sub>CC</sub> = Mil C <sub>L</sub> = 50 pF		T <sub>A</sub> , V <sub>CC</sub> = Com C <sub>L</sub> = 50 pF			
		Min	Typ	Max	Min	Max	Min	Max		
f <sub>max</sub>	Maximum Shift Frequency	50	75				50	MHz	3-1, 3-7	
t <sub>PLH</sub> t <sub>PHL</sub>	Propagation Delay I/O <sub>n</sub> to EQ	9.5 6.0	16 9.4	20 12			9.5 6.0	22.5 13	ns	3-1 3-10
t <sub>PLH</sub> t <sub>PHL</sub>	Propagation Delay I/O <sub>n</sub> to GT	8.5 7.0	14.1 11.3	18 14.5			8.5 7.0	19 15.5		
t <sub>PLH</sub> t <sub>PHL</sub>	Propagation Delay I/O <sub>n</sub> to LT	7.0 6.0	11.7 10.2	16 14			7.0 6.0	18 15		
t <sub>PLH</sub> t <sub>PHL</sub>	Propagation Delay I/O <sub>n</sub> to C/SO	9.0 6.0	15.2 10.4	19.5 13			9.0 6.0	21.5 14	ns	3-1 3-10
t <sub>PLH</sub> t <sub>PHL</sub>	Propagation Delay CP to EQ	10.5 4.0	17.5 7.0	22 9.0			10.5 3.5	24.5 10	ns	3-1 3-7
t <sub>PLH</sub> t <sub>PHL</sub>	Propagation Delay CP to GT	10 9.0	16.5 15.3	21 20			10 9.0	22 21.5		
t <sub>PLH</sub> t <sub>PHL</sub>	Propagation Delay CP to LT	9.0 6.0	15.5 9.6	19.5 12.5			9.0 6.0	21 13.5		
t <sub>PLH</sub>	Propagation Delay CP to C/SO (Compare)	8.5	14.5	18.5			8.5	21.5	ns	3-1 3-7
t <sub>PLH</sub> t <sub>PHL</sub>	Propagation Delay CP to C/SO (Serial Shift)	5.0 5.0	8.3 7.6	10.5 10			5.0 5.0	11.5 11		
t <sub>PLH</sub> t <sub>PHL</sub>	Propagation Delay C/SI to GT	9.0 3.5	14.9 6.5	19 8.5			9.0 3.0	20 9.5	ns	3-1 3-3
t <sub>PLH</sub> t <sub>PHL</sub>	Propagation Delay C/SI to LT	8.0 4.0	13.5 6.5	17 8.5			8.0 4.0	18 9.5		

## AC Characteristics (Cont'd): See Section 3 for waveforms and load configurations

Symbol	Parameter	54F/74F			54F		74F		Units	Fig. No.
		T <sub>A</sub> = +25°C, V <sub>CC</sub> = +5.0 V C <sub>L</sub> = 50 pF			T <sub>A</sub> , V <sub>CC</sub> = Mil C <sub>L</sub> = 50 pF		T <sub>A</sub> , V <sub>CC</sub> = Com C <sub>L</sub> = 50 pF			
		Min	Typ	Max	Min	Max	Min	Max		
t <sub>PLH</sub> t <sub>PHL</sub>	Propagation Delay S <sub>0</sub> , S <sub>1</sub> to C/SO	7.0 6.0	11.3 9.3	14.5 12			7.0 6.0	15.5 13	ns	3-1 3-10
t <sub>PLH</sub> t <sub>PHL</sub>	Propagation Delay SE to EQ	4.0 2.5	6.3 4.6	8.0 6.0			4.0 2.5	9.0 6.5	ns	3-1 3-4
t <sub>PLH</sub> t <sub>PHL</sub>	Propagation Delay SE to GT	7.5 3.5	12.5 6.5	16 8.0			7.5 3.5	17 9.0		
t <sub>PLH</sub> t <sub>PHL</sub>	Propagation Delay SE to LT	5.0 3.5	8.5 6.2	11 8.0			5.0 3.5	12 9.0	ns	3-1 3-4
t <sub>PLH</sub> t <sub>PHL</sub>	Propagation Delay C/SI to C/SO	4.5 4.0	7.4 7.3	9.5 9.5			4.5 4.0	10.5 10.5	ns	3-1 3-4
t <sub>PLH</sub> t <sub>PHL</sub>	Propagation Delay M to GT	8.0 7.0	13.4 12.1	17 15.5			8.0 7.0	18 17	ns	3-1 3-10
t <sub>PLH</sub> t <sub>PHL</sub>	Propagation Delay M to LT	8.5 5.5	14.4 9.4	19 12			8.5 5.5	21 13		
t <sub>PZH</sub> t <sub>PZL</sub>	Output Enable Time S <sub>0</sub> , S <sub>1</sub> to I/O <sub>n</sub>	6.0 6.5	10.1 11.2	13 14.5			6.0 6.5	14 15.5	ns	3-1 3-12 3-13
t <sub>PHZ</sub> t <sub>PLZ</sub>	Output Disable Time S <sub>0</sub> , S <sub>1</sub> to I/O <sub>n</sub>	5.0 5.5	7.9 9.6	10 12.5			5.0 5.5	11 13.5		

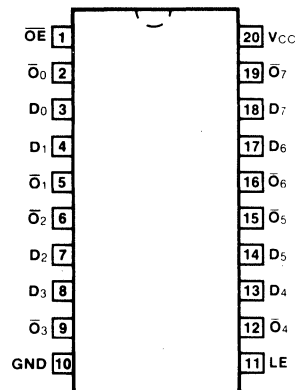
## AC Operating Requirements: See Section 3 for waveforms

Symbol	Parameter	54F/74F			54F		74F		Units	Fig. No.
		T <sub>A</sub> = +25°C, V <sub>CC</sub> = +5.0 V			T <sub>A</sub> , V <sub>CC</sub> = Mil		T <sub>A</sub> , V <sub>CC</sub> = Com			
		Min	Typ	Max	Min	Max	Min	Max		
t <sub>s</sub> (H) t <sub>s</sub> (L)	Setup Time, HIGH or LOW I/O <sub>n</sub> to CP	5.0 5.0					5.0 5.0		ns	3-5
t <sub>h</sub> (H) t <sub>h</sub> (L)	Hold Time, HIGH or LOW I/O <sub>n</sub> to CP	0 0					0 0			
t <sub>s</sub> (H) t <sub>s</sub> (L)	Setup Time, HIGH or LOW S <sub>0</sub> , S <sub>1</sub> to CP	10 10					10 10		ns	3-5
t <sub>s</sub> (H) t <sub>s</sub> (L)	Setup Time, HIGH or LOW C/SI to CP	5.0 7.0					5.0 7.0		ns	3-5
t <sub>h</sub> (H) t <sub>h</sub> (L)	Hold Time, HIGH or LOW C/SI to CP	0 0					0 0			
t <sub>w</sub> (H)	Clock Pulse Width HIGH	4.0					4.0		ns	3-7

# 54F/74F533

Octal Transparent Latch  
(With 3-State Outputs)

## Connection Diagram

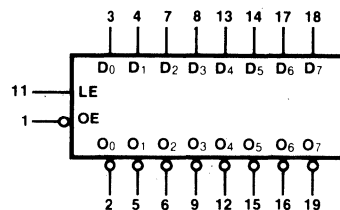


### Description

The 'F533 consists of eight latches with 3-state outputs for bus organized system applications. The flip-flops appear transparent to the data when Latch Enable (LE) is HIGH. When LE is LOW, the data that meets the setup times is latched. Data appears on the bus when the Output Enable ( $\overline{OE}$ ) is LOW. When  $\overline{OE}$  is HIGH the bus output is in the high-impedance state. The 'F533 is the same as the 'F373, except that the outputs are inverted. For description and logic diagram please see the 'F373 data sheet.

- Eight Latches in a Single Package
- 3-State Outputs for Bus Interfacing

### Logic Symbol



$V_{CC}$  = Pin 20  
GND = Pin 10

Ordering Code: See Section 6

Pkgs	Commercial Grade	Military Grade	Pkg Type
	$V_{CC} = +5.0\text{ V} \pm 5\%$ , $T_A = 0^\circ\text{ C to } +70^\circ\text{ C}$	$V_{CC} = +5.0\text{ V} \pm 10\%$ , $T_A = -55^\circ\text{ C to } +125^\circ\text{ C}$	
Plastic DIP (P)	74F533PC		9Z
Ceramic DIP (D)	74F533DC	54F533DM	4E
Flatpak (F)		54F533FM	4D

Input Loading/Fan-Out: See Section 3 for U.L. definitions

Pin Names	Description	54F/74F (U.L.) HIGH/LOW
$D_0 - D_7$	Data Inputs	0.5/0.375
LE	Latch Enable Input (Active HIGH)	0.5/0.375
$\overline{OE}$	Output Enable Input (Active LOW)	0.5/0.375
$\overline{O}_0 - \overline{O}_7$	Complementary 3-State Outputs	25/12.5

**DC Characteristics over Operating Temperature Range** (unless otherwise specified)

Symbol	Parameter	54F/74F			Units	Conditions
		Min	Typ	Max		
I <sub>CCZ</sub>	Power Supply Current		41	61	mA	V <sub>CC</sub> = Max, $\overline{OE}$ = 4.5 V D <sub>n</sub> , LE = Gnd

**AC Characteristics:** See Section 3 for waveforms and load configurations

Symbol	Parameter	54F/74F			54F		74F		Units	Fig. No.
		T <sub>A</sub> = +25°C, V <sub>CC</sub> = +5.0 V C <sub>L</sub> = 50 pF			T <sub>A</sub> , V <sub>CC</sub> = Mil C <sub>L</sub> = 50 pF		T <sub>A</sub> , V <sub>CC</sub> = Com C <sub>L</sub> = 50 pF			
		Min	Typ	Max	Min	Max	Min	Max		
t <sub>PLH</sub> t <sub>PHL</sub>	Propagation Delay D <sub>n</sub> to $\overline{O}_n$	4.0 3.0	6.9 5.2	9.0 7.0	4.0 3.0	12 9.0	4.0 3.0	10 8.0	ns	3-1 3-3
t <sub>PLH</sub> t <sub>PHL</sub>	Propagation Delay LE to $\overline{O}_n$	5.0 3.0	8.5 5.6	11 7.0	5.0 3.0	14 9.0	5.0 3.0	13 8.0	ns	3-1 3-7
t <sub>PZH</sub> t <sub>PZL</sub>	Output Enable Time	2.0 2.0	7.7 5.1	10 6.5	2.0 2.0	12.5 9.0	2.0 2.0	11 7.5	ns	3-1, 3-12 3-13
t <sub>PHZ</sub> t <sub>PLZ</sub>	Output Disable Time	2.0 2.0	4.7 4.1	6.0 5.5	2.0 2.0	8.5 7.5	2.0 2.0	7.0 6.5	ns	3-1, 3-12 3-13

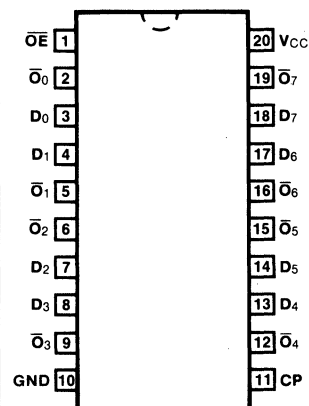
**AC Operating Requirements:** See Section 3 for waveforms

Symbol	Parameter	54F/74F			54F		74F		Units	Fig. No.
		T <sub>A</sub> = +25°C, V <sub>CC</sub> = +5.0 V			T <sub>A</sub> , V <sub>CC</sub> = Mil		T <sub>A</sub> , V <sub>CC</sub> = Com			
		Min	Typ	Max	Min	Max	Min	Max		
t <sub>s</sub> (H) t <sub>s</sub> (L)	Setup Time, HIGH or LOW D <sub>n</sub> to LE	2.0 2.0			2.0 2.0		2.0 2.0		ns	3-15
t <sub>h</sub> (H) t <sub>h</sub> (L)	Hold Time, HIGH or LOW D <sub>n</sub> to LE	3.0 3.0			3.0 3.0		3.0 3.0		ns	3-15
t <sub>w</sub> (H)	LE Pulse Width HIGH	6.0			6.0		6.0		ns	3-7

# 54F/74F534

Octal D-Type Flip-Flop  
(With 3-State Outputs)

## Connection Diagram



### Description

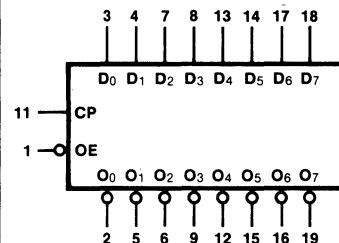
The 'F534 is a high-speed, low-power octal D-type flip-flop featuring separate D-type inputs for each flip-flop and 3-state outputs for bus oriented applications. A buffered Clock (CP) and Output Enable ( $\overline{OE}$ ) are common to all flip-flops. The 'F534 is the same as the 'F374 except that the outputs are inverted.

- Edge-triggered D-Type Inputs
- Buffered Positive Edge-triggered Clock
- 3-State Outputs for Bus Oriented Applications

Ordering Code: See Section 6

Pkgs	Commercial Grade	Military Grade	Pkg Type
	$V_{CC} = +5.0\text{ V} \pm 5\%$ , $T_A = 0^\circ\text{C to } +70^\circ\text{C}$	$V_{CC} = +5.0\text{ V} \pm 10\%$ , $T_A = -55^\circ\text{C to } +125^\circ\text{C}$	
Plastic DIP (P)	74F534PC		9Z
Ceramic DIP (D)	74F534DC	54F534DM	4E
Flatpak (F)		54F534FM	4D

## Logic Symbol



$V_{CC}$  = Pin 20  
GND = Pin 10

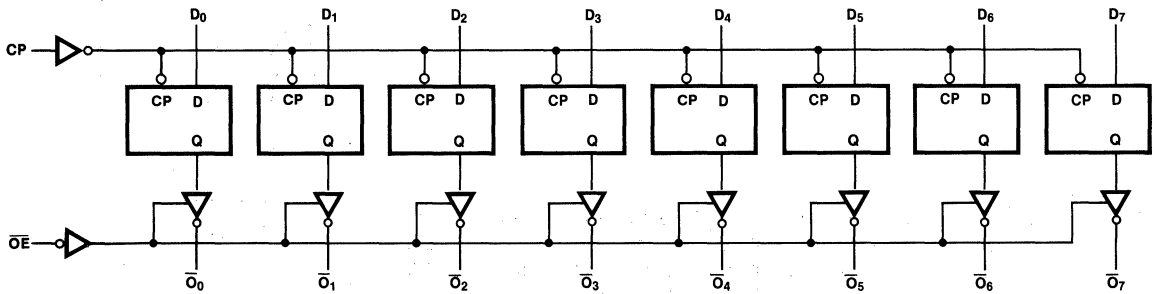
Input Loading/Fan-Out: See Section 3 for U.L. definitions

Pin Names	Description	54F/74F (U.L.) HIGH/LOW
$D_0 - D_7$	Data Inputs	0.5/0.375
CP	Clock Pulse Input (Active Rising Edge)	0.5/0.375
$\overline{OE}$	3-State Output Enable Input (Active LOW)	0.5/0.375
$\overline{O}_0 - \overline{O}_7$	Complementary 3-State Outputs	25/12.5



**Functional Description**

The 'F534 consists of eight edge-triggered flip-flops with individual D-type inputs and 3-state true outputs. The buffered clock and buffered Output Enable are common to all flip-flops. The eight flip-flops will store the state of their individual D inputs that meet the setup and hold times requirements on the LOW-to-HIGH Clock (CP) transition. With the Output Enable ( $\overline{OE}$ ) LOW, the contents of the eight flip-flops are available at the outputs. When the  $\overline{OE}$  is HIGH, the outputs go to the high impedance state. Operation of the  $\overline{OE}$  input does not affect the state of the flip-flops.

**Logic Diagram**

Please note that this diagram is provided only for the understanding of logic operations and should not be used to estimate propagation delays.

**DC Characteristics over Operating Temperature Range** (unless otherwise specified)

Symbol	Parameter	54F/74F			Units	Conditions
		Min	Typ	Max		
I <sub>CCZ</sub>	Power Supply Current (All Outputs OFF)		55	86	mA	V <sub>CC</sub> = Max, D <sub>n</sub> = Gnd OE = 4.5 V

**AC Characteristics:** See Section 3 for waveforms and load configurations

Symbol	Parameter	54F/74F			54F		74F		Units	Fig. No.
		T <sub>A</sub> = +25°C, V <sub>CC</sub> = +5.0 V C <sub>L</sub> = 50 pF			T <sub>A</sub> , V <sub>CC</sub> = Mil C <sub>L</sub> = 50 pF		T <sub>A</sub> , V <sub>CC</sub> = Com C <sub>L</sub> = 50 pF			
		Min	Typ	Max	Min	Max	Min	Max		
f <sub>max</sub>	Maximum Clock Frequency	100			60		70	MHz	3-1, 3-7	
t <sub>PLH</sub>	Propagation Delay	4.0	6.5	8.5	4.0	10.5	4.0	10	ns	3-1 3-7
t <sub>PHL</sub>	CP to $\bar{O}_n$	4.0	6.5	8.5	4.0	11	4.0	10		
t <sub>PZH</sub>	Output Enable Time	2.0	9.0	11.5	2.0	14	2.0	12.5	ns	3-1 3-12
t <sub>PZL</sub>		2.0	5.8	7.5	2.0	10	2.0	8.5		
t <sub>PHZ</sub>	Output Disable Time	2.0	5.3	7.0	2.0	8.0	2.0	8.0	ns	3-13
t <sub>PLZ</sub>		2.0	4.3	5.5	2.0	7.5	2.0	6.5		

**AC Operating Requirements:** See Section 3 for waveforms

Symbol	Parameter	54F/74F			54F		74F		Units	Fig. No.
		T <sub>A</sub> = +25°C, V <sub>CC</sub> = +5.0 V			T <sub>A</sub> , V <sub>CC</sub> = Mil		T <sub>A</sub> , V <sub>CC</sub> = Com			
		Min	Typ	Max	Min	Max	Min	Max		
t <sub>s</sub> (H)	Setup Time, HIGH or LOW D <sub>n</sub> to CP	2.0			2.5		2.0	ns	3-5	
t <sub>s</sub> (L)		2.0			2.0		2.0			
t <sub>h</sub> (H)	Hold Time, HIGH or LOW D <sub>n</sub> to CP	2.0			2.0		2.0	ns	3-5	
t <sub>h</sub> (L)		2.0			2.5		2.0			
t <sub>w</sub> (H)	CP Pulse Width, HIGH or LOW	7.0			7.0		7.0	ns	3-7	
t <sub>w</sub> (L)		6.0			6.0		6.0			

■ Test limits in screened columns are preliminary.

# 54F/74F537

## 1-of-10 Decoder

(With 3-State Outputs)

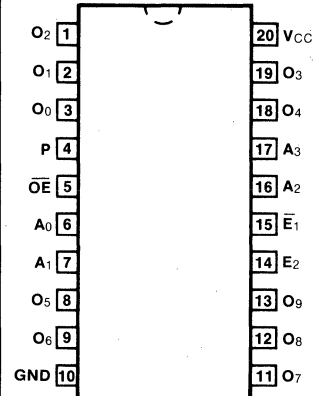
### Description

The 'F537 is a one-of-ten decoder/demultiplexer with four active-HIGH BCD inputs and ten mutually exclusive outputs. A polarity control input determines whether the outputs are active LOW or active HIGH. The 'F537 has 3-state outputs, and a HIGH signal on the Output Enable ( $\overline{OE}$ ) input forces all outputs to the high-impedance state. Two input enables, active-HIGH  $E_2$  and active-LOW  $\overline{E}_1$ , are available for demultiplexing data to the selected output in either non-inverted or inverted form. Input codes greater than BCD nine cause all outputs to go to the inactive state (i.e., same polarity as the P input).

**Ordering Code:** See Section 6

Pkgs	Commercial Grade	Military Grade	Pkg Type
	$V_{CC} = +5.0 \text{ V} \pm 5\%$ , $T_A = 0^\circ \text{ C to } +70^\circ \text{ C}$	$V_{CC} = +5.0 \text{ V} \pm 10\%$ , $T_A = -55^\circ \text{ C to } +125^\circ \text{ C}$	
Plastic DIP (P)	74F537PC		9Z
Ceramic DIP (D)	74F537DC	54F537DM	4E
Flatpak (F)		54F537FM	4D

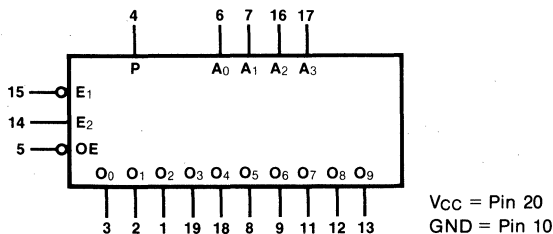
### Connection Diagram



**Input Loading/Fan-Out:** See Section 3 for U.L. definitions

Pin Names	Description	54F/74F (U.L.) HIGH/LOW
$A_0 - A_3$	Address Inputs	0.5/0.375
$\overline{E}_1$	Enable Input (Active LOW)	0.5/0.375
$E_2$	Enable Input (Active HIGH)	0.5/0.375
$\overline{OE}$	Output Enable Input (Active LOW)	0.5/0.375
P	Polarity Control Input	0.5/0.375
$O_0 - O_9$	3-State Outputs	25/12.5

### Logic Symbol



Truth Table

FUNCTION	INPUTS							OUTPUTS										
	$\overline{OE}$	$\overline{E_1}$	$E_2$	$A_3$	$A_2$	$A_1$	$A_0$	$O_0$	$O_1$	$O_2$	$O_3$	$O_4$	$O_5$	$O_6$	$O_7$	$O_8$	$O_9$	
High Impedance	H	X	X	X	X	X	X	Z	Z	Z	Z	Z	Z	Z	Z	Z	Z	
Disable	L	H	X	X	X	X	X	Outputs Equal P Input										
Active-HIGH Output (P = L)	L	L	H	L	L	L	L	H	L	L	L	L	L	L	L	L	L	
	L	L	H	L	L	L	H	L	H	L	L	L	L	L	L	L	L	
	L	L	H	L	L	H	L	L	L	H	L	L	L	L	L	L	L	
	L	L	H	L	L	H	H	L	L	L	H	L	L	L	L	L	L	
	L	L	H	L	H	L	H	L	L	L	L	H	L	L	L	L	L	
	L	L	H	L	H	L	H	L	L	L	L	L	L	L	L	L	L	
	L	L	H	L	H	H	L	L	L	L	L	L	L	L	L	L	L	
	L	L	H	L	H	H	H	L	L	L	L	L	L	L	L	L	L	
	L	L	H	H	L	L	L	L	L	L	L	L	L	L	L	L	L	
	L	L	H	H	L	L	H	L	L	L	L	L	L	L	L	L	L	
	L	L	H	H	X	H	X	L	L	L	L	L	L	L	L	L	L	
	L	L	H	H	H	X	X	L	L	L	L	L	L	L	L	L	L	
	Active-LOW Output (P = H)	L	L	H	L	L	L	L	L	H	H	H	H	H	H	H	H	H
		L	L	H	L	L	L	H	H	L	H	H	H	H	H	H	H	H
L		L	H	L	L	H	L	H	H	L	H	H	H	H	H	H	H	
L		L	H	L	L	H	H	H	H	L	H	H	H	H	H	H	H	
L		L	H	L	H	L	L	H	H	H	L	H	H	H	H	H	H	
L		L	H	L	H	H	L	H	H	H	H	L	H	H	H	H	H	
L		L	H	L	H	H	H	H	H	H	H	L	H	H	H	H		
L		L	H	H	L	L	L	H	H	H	H	H	H	H	L	H	H	
L		L	H	H	L	L	H	H	H	H	H	H	H	H	H	L	H	
L		L	H	H	X	H	X	H	H	H	H	H	H	H	H	H	H	
L		L	H	H	H	X	X	H	H	H	H	H	H	H	H	H	H	

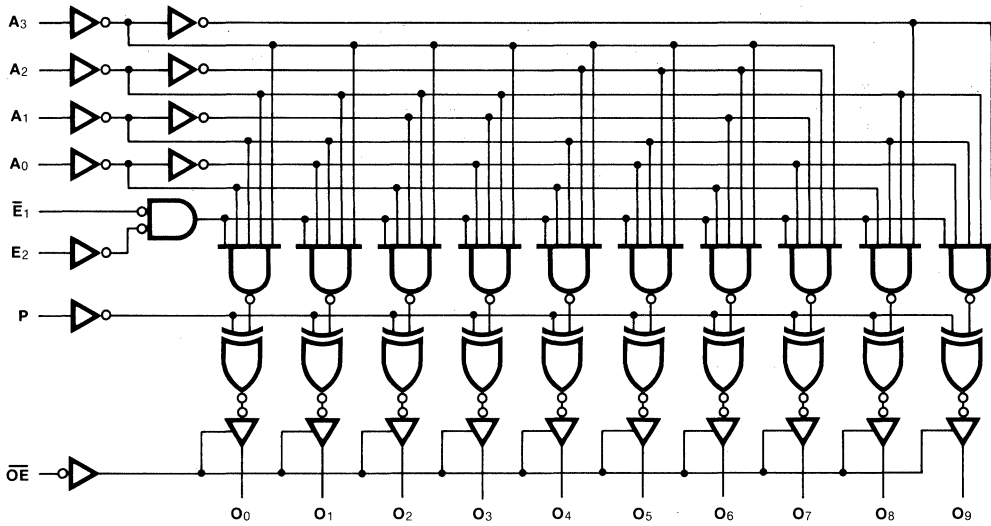
H = HIGH Voltage Level

L = LOW Voltage Level

X = Immaterial

Z = High Impedance

**Logic Diagram**



Please note that this diagram is provided only for the understanding of logic operations and should not be used to estimate propagation delays.

**DC Characteristics over Operating Temperature Range** (unless otherwise specified)

Symbol	Parameter	54F/74F			Units	Conditions
		Min	Typ	Max		
I <sub>CCZ</sub>	Power Supply Current		44	66	mA	A <sub>0</sub> - A <sub>3</sub> , $\overline{E}_1$ = Gnd $\overline{OE}$ , E <sub>2</sub> , P = HIGH

**AC Characteristics:** See Section 3 for waveforms and load configurations

Symbol	Parameter	54F/74F			54F		74F		Units	Fig. No.
		T <sub>A</sub> = +25°C, V <sub>CC</sub> = +5.0 V C <sub>L</sub> = 50 pF			T <sub>A</sub> , V <sub>CC</sub> = Mil C <sub>L</sub> = 50 pF		T <sub>A</sub> , V <sub>CC</sub> = Com C <sub>L</sub> = 50 pF			
		Min	Typ	Max	Min	Max	Min	Max		
t <sub>PLH</sub> t <sub>PHL</sub>	Propagation Delay A <sub>n</sub> to O <sub>n</sub>	6.0 4.0	11 7.5	16 11			6.0 4.0	17 12	ns	3-1 3-10
t <sub>PLH</sub> t <sub>PHL</sub>	Propagation Delay $\overline{E}_1$ to O <sub>n</sub>	5.0 4.0	8.5 6.5	12 9.0			5.0 4.0	13 10		
t <sub>PLH</sub> t <sub>PHL</sub>	Propagation Delay E <sub>2</sub> to O <sub>n</sub>	6.0 5.0	11 10	16 14			6.0 5.0	17 15	ns	3-1 3-10
t <sub>PLH</sub> t <sub>PHL</sub>	Propagation Delay P to O <sub>n</sub>	6.0 6.0	11.5 11	16 16			6.0 6.0	17 17		
t <sub>PZH</sub> t <sub>PZL</sub>	Output Enable Time $\overline{OE}$ to O <sub>n</sub>	3.0 5.0	5.5 9.0	8.0 13			3.0 5.0	9.0 14	ns	3-1 3-12 3-13
t <sub>PHZ</sub> t <sub>PLZ</sub>	Output Disable Time $\overline{OE}$ to O <sub>n</sub>	2.0 3.0	4.0 5.0	6.0 7.0			2.0 3.0	7.0 8.0		

# 54F/74F538

## 1-of-8 Decoder

(With 3-State Outputs)

### Description

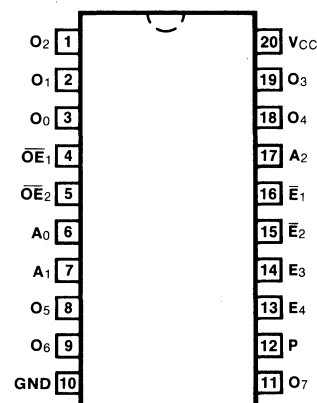
The 'F538 decoder/demultiplexer accepts three Address ( $A_0 - A_2$ ) input signals and decodes them to select one of eight mutually exclusive outputs. A polarity control input (P) determines whether the outputs are active LOW or active HIGH. A HIGH signal on either of the active-LOW Output Enable ( $\overline{OE}$ ) inputs forces all outputs to the high-impedance state. Two active-HIGH and two active-LOW input enables are available for easy expansion to 1-of-32 decoding with four packages, or for data demultiplexing to one-of-eight or one-of-16 destinations.

- Output Polarity Control
- Data Demultiplexing Capability
- Multiple Enables for Expansion
- 3-State Outputs

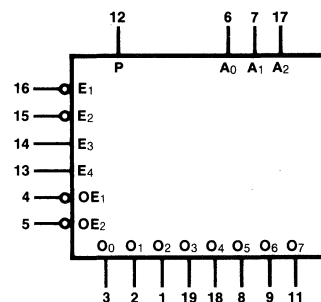
Ordering Code: See Section 6

Pkgs	Commercial Grade	Military Grade	Pkg Type
	$V_{CC} = +5.0\text{ V} \pm 5\%$ , $T_A = 0^\circ\text{ C to } +70^\circ\text{ C}$	$V_{CC} = +5.0\text{ V} \pm 10\%$ , $T_A = -55^\circ\text{ C to } +125^\circ\text{ C}$	
Plastic DIP (P)	74F538PC		9Z
Ceramic DIP (D)	74F538DC	54F538DM	4E
Flatpak (F)		54F538FM	4D

### Connection Diagram



### Logic Symbol



$V_{CC} = \text{Pin } 20$   
GND = Pin 10

Input Loading/Fan-Out: See Section 3 for U.L. definitions

Pin Names	Description	54F/74F (U.L.) HIGH/LOW
$A_0 - A_2$	Address Inputs	0.5/0.375
$\overline{E}_1, \overline{E}_2$	Enable Inputs (Active LOW)	0.5/0.375
$E_3, E_4$	Enable Inputs (Active HIGH)	0.5/0.375
P	Polarity Control Input	0.5/0.375
$\overline{OE}_1, \overline{OE}_2$	Output Enable Inputs (Active LOW)	0.5/0.375
$O_0 - O_7$	3-State Outputs	25/12.5

Truth Table

FUNCTION	INPUTS									OUTPUTS							
	$\overline{OE}_1$	$\overline{OE}_2$	$\overline{E}_1$	$\overline{E}_2$	$E_3$	$E_4$	$A_2$	$A_1$	$A_0$	$O_0$	$O_1$	$O_2$	$O_3$	$O_4$	$O_5$	$O_6$	$O_7$
High Impedance	H	X	X	X	X	X	X	X	X	Z	Z	Z	Z	Z	Z	Z	Z
	X	H	X	X	X	X	X	X	X	Z	Z	Z	Z	Z	Z	Z	Z
Disable	L	L	H	X	X	X	X	X	X	Outputs Equal P Input							
	L	L	X	H	X	X	X	X	X								
	L	L	X	X	L	X	X	X	X								
	L	L	X	X	X	L	X	X	X								
Active-HIGH Output (P = L)	L	L	L	L	H	H	L	L	L	H	L	L	L	L	L	L	L
	L	L	L	L	H	H	L	L	H	L	H	L	L	L	L	L	L
	L	L	L	L	H	H	L	H	L	L	L	H	L	L	L	L	L
	L	L	L	L	H	H	L	H	H	L	L	L	H	L	L	L	L
	L	L	L	L	H	H	H	L	L	L	L	L	L	H	L	L	L
	L	L	L	L	H	H	H	L	H	L	L	L	L	L	H	L	L
	L	L	L	L	H	H	H	H	L	L	L	L	L	L	L	H	L
	L	L	L	L	H	H	H	H	H	L	L	L	L	L	L	L	H
Active-LOW Output (P = H)	L	L	L	L	H	H	L	L	L	L	H	H	H	H	H	H	H
	L	L	L	L	H	H	L	L	H	H	L	H	H	H	H	H	H
	L	L	L	L	H	H	L	H	L	H	H	L	H	H	H	H	H
	L	L	L	L	H	H	L	H	H	H	H	L	H	H	H	H	H
	L	L	L	L	H	H	H	L	L	H	H	H	L	H	H	H	H
	L	L	L	L	H	H	H	L	H	H	H	H	H	H	L	H	H
	L	L	L	L	H	H	H	H	L	H	H	H	H	H	H	L	H
	L	L	L	L	H	H	H	H	H	H	H	H	H	H	H	H	L

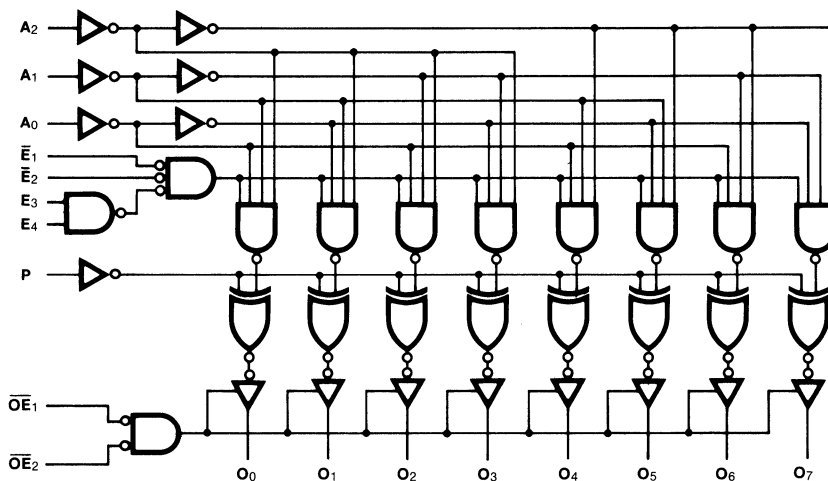
H = HIGH Voltage Level

L = LOW Voltage Level

X = Immaterial

Z = High Impedance

## Logic Diagram



Please note that this diagram is provided only for the understanding of logic operations and should not be used to estimate propagation delays.

## DC Characteristics over Operating Temperature Range (unless otherwise specified)

Symbol	Parameter	54F/74F			Units	Conditions
		Min	Typ	Max		
I <sub>CCZ</sub>	Power Supply Current		37	56	mA	A <sub>0</sub> - A <sub>2</sub> , $\overline{E}_1$ , $\overline{E}_2$ = Gnd $\overline{OE}_1$ , $\overline{OE}_2$ , E <sub>3</sub> , E <sub>4</sub> , P = HIGH

## AC Characteristics: See Section 3 for waveforms and load configurations

Symbol	Parameter	54F/74F			54F		74F		Units	Fig. No.
		T <sub>A</sub> = +25°C, V <sub>CC</sub> = +5.0 V C <sub>L</sub> = 50 pF			T <sub>A</sub> , V <sub>CC</sub> = Mil C <sub>L</sub> = 50 pF		T <sub>A</sub> , V <sub>CC</sub> = Com C <sub>L</sub> = 50 pF			
		Min	Typ	Max	Min	Max	Min	Max		
t <sub>PLH</sub>	Propagation Delay	6.0	11	16			6.0	17	ns	3-1 3-10
t <sub>PHL</sub>	A <sub>n</sub> to O <sub>n</sub>	4.0	7.5	11			4.0	12		
t <sub>PLH</sub>	Propagation Delay	5.0	8.5	12			5.0	13	ns	3-1 3-10
t <sub>PHL</sub>	$\overline{E}_1$ or $\overline{E}_2$ to O <sub>n</sub>	4.0	6.5	9.0			4.0	10		
t <sub>PLH</sub>	Propagation Delay	6.0	11	16			6.0	17	ns	3-1 3-10
t <sub>PHL</sub>	E <sub>3</sub> or E <sub>4</sub> to O <sub>n</sub>	5.0	10	14			5.0	15		
t <sub>PLH</sub>	Propagation Delay	6.0	11.5	16			6.0	17	ns	3-1 3-12
t <sub>PHL</sub>	P to O <sub>n</sub>	6.0	11	16			6.0	17		
t <sub>PZH</sub>	Output Enable Time	3.0	5.5	8.0			3.0	9.0	ns	3-1 3-13
t <sub>PZL</sub>	$\overline{OE}_1$ or $\overline{OE}_2$ to O <sub>n</sub>	5.0	9.0	13			5.0	14		
t <sub>PHZ</sub>	Output Disable Time	2.0	4.0	6.0			2.0	7.0	ns	3-13
t <sub>P LZ</sub>	$\overline{OE}_1$ or $\overline{OE}_2$ to O <sub>n</sub>	3.0	5.0	9.0			3.0	8.0		



# 54F/74F539

Dual 1-of-4 Decoder  
(With 3-State Outputs)

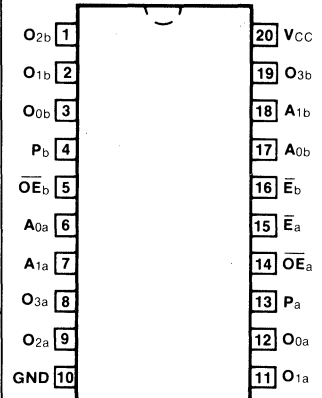
### Description

The 'F539 contains two independent decoders. Each accepts two Address ( $A_0$ ,  $A_1$ ) input signals and decodes them to select one of four mutually exclusive outputs. A polarity control input ( $P$ ) determines whether the outputs are active HIGH ( $P = L$ ) or active LOW ( $P = H$ ). An active-LOW input Enable ( $\overline{E}$ ) is available for data demultiplexing; data is routed to the selected output in non-inverted form in the active-LOW mode or in inverted form in the active-HIGH mode. A HIGH signal on the active-LOW Output Enable ( $\overline{OE}$ ) input forces the 3-state outputs to the high impedance state.

Ordering Code: See Section 6

Pkgs	Commercial Grade	Military Grade	Pkg Type
	$V_{CC} = +5.0\text{ V} \pm 5\%$ , $T_A = 0^\circ\text{ C to } +70^\circ\text{ C}$	$V_{CC} = +5.0\text{ V} \pm 10\%$ , $T_A = -55^\circ\text{ C to } +125^\circ\text{ C}$	
Plastic DIP (P)	74F539PC		9Z
Ceramic DIP (D)	74F539DC	54F539DM	4E
Flatpak (F)		54F539FM	4D

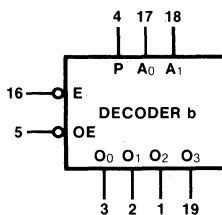
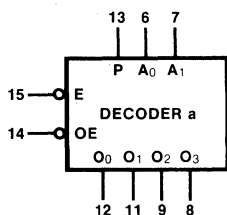
### Connection Diagram



Input Loading/Fan-Out: See Section 3 for U.L. definitions

Pin Names	Description	54F/74F (U.L.) HIGH/LOW
$A_{0a} - A_{1a}$	Side A Address Inputs	0.5/0.375
$A_{0b} - A_{1b}$	Side B Address Inputs	0.5/0.375
$\overline{E}_a, \overline{E}_b$	Enable Inputs (Active LOW)	0.5/0.375
$\overline{OE}_a, \overline{OE}_b$	Output Enable Inputs (Active LOW)	0.5/0.375
$P_a, P_b$	Polarity Control Inputs	0.5/0.375
$O_{0a} - O_{3a}$	Side A 3-State Outputs	25/12.5
$O_{0b} - O_{3b}$	Side B 3-State Outputs	25/12.5

### Logic Symbol



$V_{CC}$  = Pin 20  
GND = Pin 10

Truth Table (each half)

FUNCTION	INPUTS				OUTPUTS			
	$\overline{OE}$	$\overline{E}$	A <sub>1</sub>	A <sub>0</sub>	O <sub>0</sub>	O <sub>1</sub>	O <sub>2</sub>	O <sub>3</sub>
High Impedance	H	X	X	X	Z	Z	Z	Z
Disable	L	H	X	X	$O_n = P$			
Active-HIGH Output (P = L)	L	L	L	L	H	L	L	L
	L	L	L	H	L	H	L	L
	L	L	H	L	L	L	H	L
	L	L	H	H	L	L	L	H
Active-LOW Output (P = H)	L	L	L	L	L	H	H	H
	L	L	L	H	H	L	H	H
	L	L	H	L	H	H	L	H
	L	L	H	H	H	H	H	L

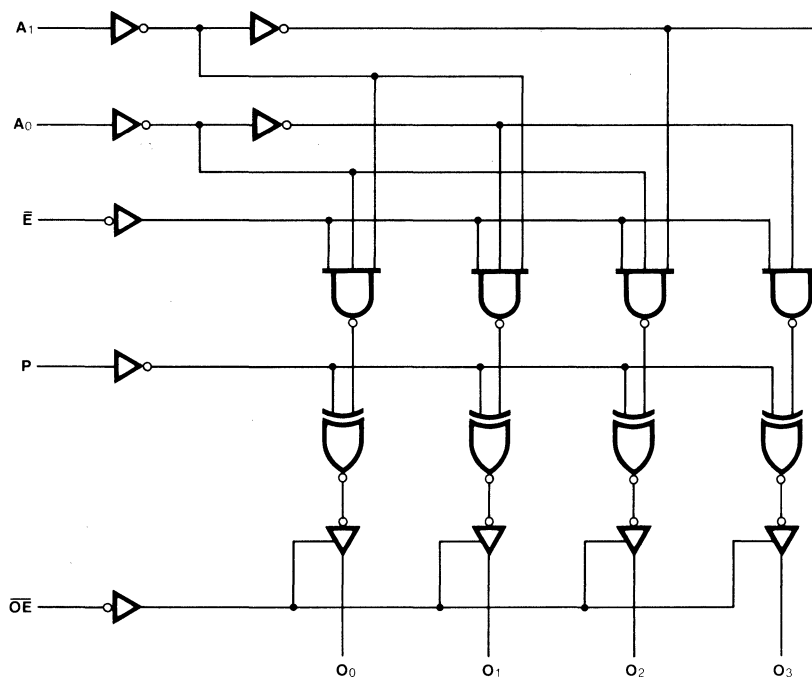
H = HIGH Voltage Level

L = LOW Voltage Level

X = Immaterial

Z = High Impedance

Logic Diagram (one half shown)



Please note that this diagram is provided only for the understanding of logic operations and should not be used to estimate propagation delays.

**DC Characteristics over Operating Temperature Range** (unless otherwise specified)

Symbol	Parameter	54F/74F			Units	Conditions
		Min	Typ	Max		
I <sub>CCZ</sub>	Power Supply Current (All Outputs OFF)		41	62	mA	A <sub>0</sub> , A <sub>1</sub> , $\overline{E}$ = Gnd $\overline{OE}$ , P = HIGH

**AC Characteristics:** See Section 3 for waveforms and load configurations

Symbol	Parameter	54F/74F			54F		74F		Units	Fig. No.
		T <sub>A</sub> = +25°C, V <sub>CC</sub> = +5.0 V C <sub>L</sub> = 50 pF			T <sub>A</sub> , V <sub>CC</sub> = Mil C <sub>L</sub> = 50 pF		T <sub>A</sub> , V <sub>CC</sub> = Com C <sub>L</sub> = 50 pF			
		Min	Typ	Max	Min	Max	Min	Max		
t <sub>PLH</sub> t <sub>PHL</sub>	Propagation Delay A <sub>n</sub> to O <sub>n</sub>	6.0 4.0	11.6 7.5	16 11				ns	3-1 3-10	
t <sub>PLH</sub> t <sub>PHL</sub>	Propagation Delay $\overline{E}$ to O <sub>n</sub>	6.0 5.0	11 10	16 14				ns	3-1 3-10	
t <sub>PLH</sub> t <sub>PHL</sub>	Propagation Delay P to O <sub>n</sub>	6.0 6.0	11.5 11	16 16				ns	3-1 3-10	
t <sub>PZH</sub> t <sub>PZL</sub>	Output Enable Time $\overline{OE}$ to O <sub>n</sub>	3.0 5.0	5.5 9.0	8.0 13				ns	3-1 3-12	
t <sub>PHZ</sub> t <sub>PLZ</sub>	Output Disable Time $\overline{OE}$ to O <sub>n</sub>	2.0 3.0	4.0 5.0	6.0 9.0						

■ Test limits in screened columns are preliminary.

# 54F/74F543 • 54F/74F544

## Octal Registered Transceiver

### Description

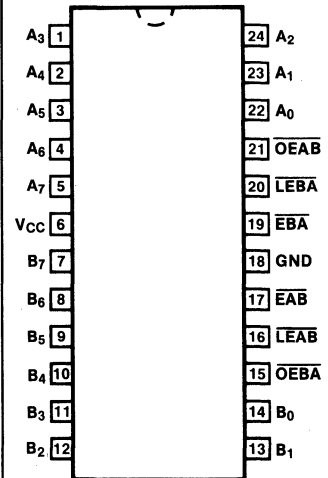
The 'F543 and 'F544 octal transceivers each contain two sets of D-type latches for temporary storage of data flowing in either direction. Separate Latch Enable and Output Enable inputs are provided for each register to permit independent control of inputting and outputting in either direction of data flow. The A outputs are guaranteed to sink 20 mA while the B outputs are rated for 64 mA. The 'F543 is non-inverting; the 'F544 inverts data in both directions.

- 8-Bit Octal Transceiver
- Back-to-Back Registers for Storage
- Separate Controls for Data Flow in Each Direction
- A Outputs Sink 20 mA, B Outputs Sink 64 mA
- Inverting and Non-Inverting Options

Ordering Code: See Section 6

Pkgs	Commercial Grade	Military Grade	Pkg Type
	V <sub>CC</sub> = +5.0 V ±5%, T <sub>A</sub> = 0°C to +70°C	V <sub>CC</sub> = +5.0 V ±10%, T <sub>A</sub> = -55°C to +125°C	
Plastic DIP (P)	74F543PC, 74F544PC		9N
Ceramic DIP (D)	74F543DC, 74F544DC	54F543DM, 54F544DM	6N
Flatpak (F)		54F543FM, 54F544FM	4M

### Connection Diagram ('F543 shown\*)



\*'F544 has inverting outputs

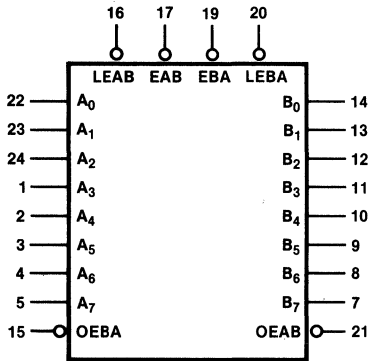
4

Input Loading/Fan-Out: See Section 3 for U.L. definitions

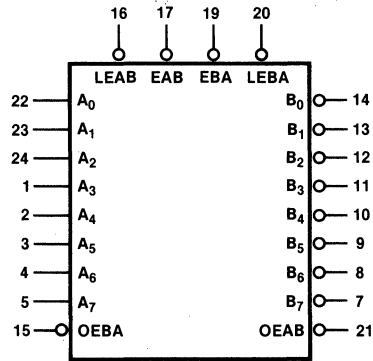
Pin Names	Description	54F/74F (U.L.) HIGH/LOW
OEAB	A-to-B Output Enable Input (Active LOW)	0.5/0.375
OEBA	B-to-A Output Enable Input (Active LOW)	0.5/0.375
EAB	A-to-B Enable Input (Active LOW)	0.5/0.375
EBA	B-to-A Enable Input (Active LOW)	0.5/0.375
LEAB	A-to-B Latch Enable Input (Active LOW)	0.5/0.375
LEBA	B-to-A Latch Enable Input (Active LOW)	0.5/0.375
A <sub>0</sub> - A <sub>7</sub>	A-to-B Data Inputs or B-to-A 3-State Outputs	1.75/0.375 25/12
B <sub>0</sub> - B <sub>7</sub>	B-to-A Data Inputs or A-to-B 3-State Outputs	1.75/0.375 25/40 (30)

## Logic Symbols

'F543

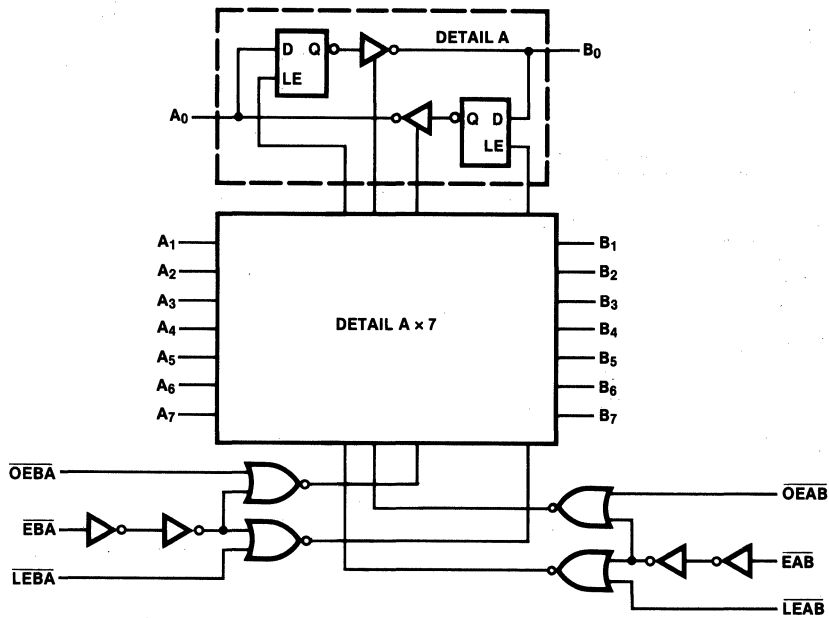


'F544



V<sub>CC</sub> = Pin 6  
GND = Pin 18

## Logic Diagram ('F543 shown)



**Functional Description**

The 'F543 and 'F544 each contain two sets of eight D-type latches, with separate input and output controls for each set. For data flow from A to B, for example, the A-to-B Enable ( $\overline{\text{EAB}}$ ) input must be LOW in order to enter data from  $A_0$ – $A_7$  or take data from  $B_0$ – $B_7$ , as indicated in the Data I/O Control Table. With  $\overline{\text{EAB}}$  LOW, A LOW signal on the A-to-B Latch Enable ( $\overline{\text{LEAB}}$ ) input makes the A-to-B latches

transparent; a subsequent LOW-to-HIGH transition of the  $\overline{\text{LEAB}}$  signal puts the A latches in the storage mode and their outputs no longer change with the A inputs. With  $\overline{\text{EAB}}$  and  $\overline{\text{OEAB}}$  both LOW, the 3-state B output buffers are active and reflect the data present at the output of the A latches. Control of data flow from B to A is similar, but using the  $\overline{\text{EBA}}$ ,  $\overline{\text{LEBA}}$  and  $\overline{\text{OEBA}}$  inputs.

**Data I/O Control Table†**

INPUTS			LATCH STATUS A-to-B	OUTPUT BUFFERS
$\overline{\text{EAB}}$	$\overline{\text{LEAB}}$	$\overline{\text{OEAB}}$		$B_0$ – $B_7$
H	X	X	Storing	High Z
X	H	—	Storing	—
X	—	H	—	High Z
L	L	L	Transparent	Current A Inputs
L	H	L	Storing	Previous* A Inputs

\*Before  $\overline{\text{LEAB}}$  LOW-to-HIGH Transition

H = HIGH Voltage Level

L = LOW Voltage Level

X = Immaterial

† A-to-B data flow shown; B-to-A flow control

is the same, except using  $\overline{\text{EBA}}$ ,  $\overline{\text{LEBA}}$  and  $\overline{\text{OEBA}}$

4

**DC Characteristics over Operating Temperature Range** (unless otherwise specified)

Symbol	Parameter	54F/74F			Units	Conditions
		Min	Typ	Max		
$V_{OH}$	Output HIGH Voltage $B_0$ – $B_7$	XM	2.0		V	$I_{OH} = -12$ mA
		XC				$I_{OH} = -15$ mA
$V_{OH}$	Output HIGH Voltage $A_n$ , $B_n$		2.4		V	$I_{OH} = -3.0$ mA
$V_{OL}$	Output LOW Voltage $B_0$ – $B_7$	XM		0.55	V	$I_{OL} = 48$ mA
		XC				$I_{OL} = 64$ mA
$I_{IH}$	Input HIGH Current Breakdown Test — $A_n$ , $B_n$			100	$\mu\text{A}$	$V_{CC} = \text{Max}$ , $V_{IN} = 5.5$ V
$I_{IH} + I_{OZH}$	3-State Output OFF Current HIGH — $A_n$ , $B_n$			70	$\mu\text{A}$	$V_{CC} = \text{Max}$ , $V_{OUT} = 2.4$ V
$I_{IL} + I_{OZL}$	3-State Output OFF Current LOW — $A_n$ , $B_n$			0.6	mA	$V_{CC} = \text{Max}$ , $V_{OUT} = 0.5$ V
$I_{OS}$	Output Short-circuit Current $B_0$ – $B_7$		-100	-225	mA	$V_{CC} = \text{Max}$
$I_{CC}$	Power Supply Current		95	140	mA	$V_{CC} = \text{Max}$

**AC Characteristics:** See Section 3 for waveforms and load configurations

Symbol	Parameter	54F/74F			54F		74F		Units	Fig. No.
		T <sub>A</sub> = +25°C, V <sub>CC</sub> = +5.0 V C <sub>L</sub> = 50 pF			T <sub>A</sub> , V <sub>CC</sub> = Mil C <sub>L</sub> = 50 pF		T <sub>A</sub> , V <sub>CC</sub> = Com C <sub>L</sub> = 50 pF			
		Min	Typ	Max	Min	Max	Min	Max		
t <sub>PLH</sub> t <sub>PHL</sub>	Propagation Delay Transparent Mode A <sub>n</sub> to B <sub>n</sub> or B <sub>n</sub> to A <sub>n</sub>	4.0	7.0	10					ns	3-1 3-3 3-4
t <sub>PLH</sub> t <sub>PHL</sub>	Propagation Delay LEBA to A <sub>n</sub>	5.5	9.0	12					ns	3-1 3-8
t <sub>PLH</sub> t <sub>PHL</sub>	Propagation Delay LEAB to B <sub>n</sub>	5.5	9.0	12					ns	3-1 3-8
t <sub>PZH</sub> t <sub>PZL</sub>	Output Enable Time OEBA or OEAB to A <sub>n</sub> or B <sub>n</sub>	6.0	10	14					ns	3-1 3-12
t <sub>PHZ</sub> t <sub>PLZ</sub>	Output Disable Time OEBA or OEAB to A <sub>n</sub> or B <sub>n</sub>	6.0	10	14						3-13

**AC Operating Requirements:** See Section 3 for waveforms

Symbol	Parameter	54F/74F			54F		74F		Units	Fig. No.
		T <sub>A</sub> = +25°C, V <sub>CC</sub> = +5.0 V			T <sub>A</sub> , V <sub>CC</sub> = Mil		T <sub>A</sub> , V <sub>CC</sub> = Com			
		Min	Typ	Max	Min	Max	Min	Max		
t <sub>s</sub> (H) t <sub>s</sub> (L)	Setup Time, HIGH or LOW A <sub>n</sub> or B <sub>n</sub> to LEBA or LEAB	5.0							ns	3-14
t <sub>h</sub> (H) t <sub>h</sub> (L)	Hold Time, HIGH or LOW A <sub>n</sub> or B <sub>n</sub> to LEBA or LEAB	2.0								

■ Test limits in screened columns are preliminary.

# 54F/74F545

## Octal Bidirectional Transceiver

(With 3-State Inputs/Outputs)

### Description

The 'F545 is an 8-bit, 3-state, high-speed transceiver. It provides bidirectional drive for bus-oriented microprocessor and digital communications systems. Straight through bidirectional transceivers are featured, with 20 mA bus drive capability on the A ports and 64 mA bus drive capability on the B ports.

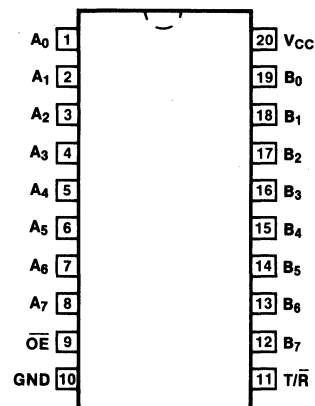
One input, Transmit/Receive ( $T/\bar{R}$ ) determines the direction of logic signals through the bidirectional transceiver. Transmit enables data from A ports to B ports; Receive enables data from B ports to A ports. The Output Enable input disables both A and B ports by placing them in a 3-state condition.

- Higher Drive than 8304
- 8-Bit Bidirectional Data Flow Reduces System Package Count
- 3-State Inputs/Outputs for Interfacing with Bus-oriented Systems
- 20 mA and 64 mA Bus Drive Capability on A and B Ports, Respectively
- Transmit/Receive and Output Enable Simplify Control Logic
- Hysteresis on Bus Inputs

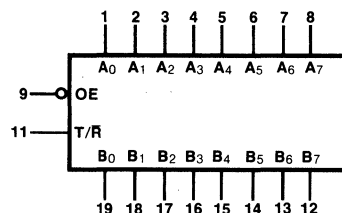
Ordering Code: See Section 6

Pkgs	Commercial Grade	Military Grade	Pkg Type
	$V_{CC} = +5.0 \text{ V} \pm 5\%$ , $T_A = 0^\circ \text{ C to } +70^\circ \text{ C}$	$V_{CC} = +5.0 \text{ V} \pm 10\%$ , $T_A = -55^\circ \text{ C to } +125^\circ \text{ C}$	
Plastic DIP (P)	74F545PC		9Z
Ceramic DIP (D)	74F545DC	54F545DM	4E
Flatpak (F)		54F545FM	4D

### Connection Diagram



### Logic Symbol



$V_{CC} = \text{Pin } 20$   
 $GND = \text{Pin } 10$

Input Loading/Fan-Out: See Section 3 for U.L. definitions

Pin Names	Description	54F/74F (U.L.) HIGH/LOW
$\overline{OE}$	Output Enable Input (Active LOW)	0.5/0.875
$T/\bar{R}$	Transmit/Receive Input	0.5/0.625
$A_0 - A_7$	Side A 3-State Inputs or 3-State Outputs	1.75/0.625 25/12.5
$B_0 - B_7$	Side B 3-State Inputs or 3-State Outputs	1.75/0.625 25/40 (30)



## Truth Table

INPUTS		OUTPUTS
$\overline{OE}$	T/R	
L	L	Bus B Data to Bus A
L	H	Bus A Data to Bus B
H	X	High Z

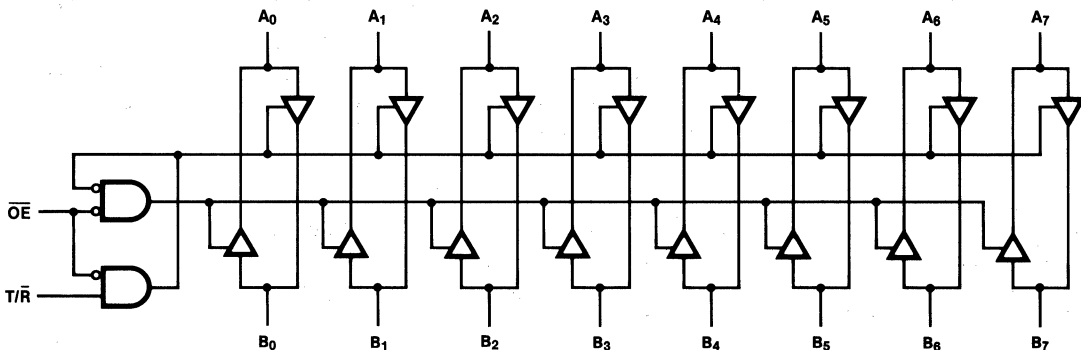
H = HIGH Voltage Level

L = LOW Voltage Level

X = Immaterial

Z = High Impedance

## Logic Diagram



## DC Characteristics over Operating Temperature Range (unless otherwise specified)

Symbol	Parameter	54F/74F			Units	Conditions	
		Min	Typ	Max			
$V_{OH}$	Output HIGH Voltage $B_0 - B_7$	XM	2.0		V	$I_{OH} = -12 \text{ mA}$	$V_{CC} = \text{Min}$
		XC	2.0			$I_{OH} = -15 \text{ mA}$	
	Output HIGH Voltage $B_0 - B_7$		2.4		V	$I_{OH} = -3.0 \text{ mA}$	
$V_{OL}$	Output LOW Voltage $B_0 - B_7$	XM		0.55	V	$I_{OL} = 48 \text{ mA}$	$V_{CC} = \text{Min}$
		XC		0.55		$I_{OL} = 64 \text{ mA}$	
$V_{T+} - V_{T-}$	Hysteresis Voltage $B_0 - B_7$	200	400		mV	$V_{CC} = \text{Min}$	
$I_{IH}$	Input HIGH Current Breakdown Test — $A_n, B_n$			100	$\mu\text{A}$	$V_{CC} = \text{Max}, V_{IN} = 5.5 \text{ V}$	
$I_{IH} + I_{OZH}$	3-State Output OFF Current HIGH — $A_n, B_n$			70	$\mu\text{A}$	$V_{CC} = \text{Max}, V_{OUT} = 2.7 \text{ V}$	
$I_{IL} + I_{OLZ}$	3-State Output OFF Current LOW — $A_n, B_n$			1.0	mA	$V_{CC} = \text{Max}, V_{OUT} = 0.5 \text{ V}$	
$I_{OS}$	Output Short-circuit Current $B_0 - B_7$	-100		-225	mA	$V_{CC} = \text{Max}, V_{OUT} = 0 \text{ V}$	
$I_{CC}$	Power Supply Current		128	192	mA	$V_{CC} = \text{Max}$	

**AC Characteristics:** See Section 3 for waveforms and load configurations

Symbol	Parameter	54F/74F			54F		74F		Units	Fig. No.
		T <sub>A</sub> = +25°C, V <sub>CC</sub> = +5.0 V C <sub>L</sub> = 50 pF			T <sub>A</sub> , V <sub>CC</sub> = Mil C <sub>L</sub> = 50 pF		T <sub>A</sub> , V <sub>CC</sub> = Com C <sub>L</sub> = 50 pF			
		Min	Typ	Max	Min	Max	Min	Max		
t <sub>PLH</sub>	Propagation Delay A <sub>n</sub> to B <sub>n</sub> or B <sub>n</sub> to A <sub>n</sub>	3.5	6.5	9.1				ns	3-1	
t <sub>PHL</sub>		3.5	6.5	9.1					3-4	
t <sub>PZH</sub>	Output Enable Time	4.0	7.0	10				ns	3-1	
t <sub>PZL</sub>		5.5	8.5	14					3-12	
t <sub>PHZ</sub>	Output Disable Time	5.5	8.5	14				ns	3-13	
t <sub>PLZ</sub>		4.0	7.0	10						

■ Test limits in screened columns are preliminary.

## 54F/74F547

Octal Decoder/Demultiplexer  
(With Address Latches and Acknowledge)

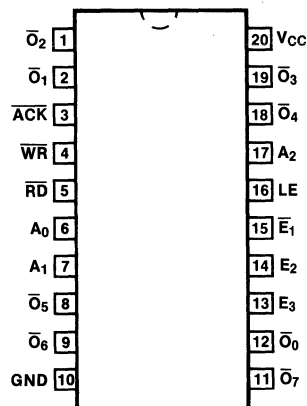
**Description**

The 'F547 is a 3-to-8 line address decoder with latches for address storage. Designed primarily to simplify multiple chip selection in a microprocessor system, it contains one active-LOW and two active-HIGH Enables to conserve address space. Also included is an active-LOW Acknowledge output that responds to either a Read or Write input signal when the Enables are active.

- 3-to-8 Line Address Decoder
- Address Storage Latches
- Multiple Enables for Address Extension
- Open-collector Acknowledge Output

**Ordering Code:** See Section 6

Pkgs	Commercial Grade	Military Grade	Pkg Type
	$V_{CC} = +5.0\text{ V} \pm 5\%$ , $T_A = 0^\circ\text{ C to } +70^\circ\text{ C}$	$V_{CC} = +5.0\text{ V} \pm 10\%$ , $T_A = -55^\circ\text{ C to } +125^\circ\text{ C}$	
Plastic DIP (P)	74F547PC		9Z
Ceramic DIP (D)	74F547DC	54F547DM	4E
Flatpak (F)		54F547FM	4D

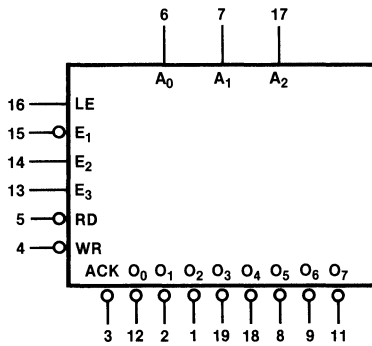
**Connection Diagram**

**Input Loading/Fan-Out:** See Section 3 for U.L. definitions

Pin Names	Description	54F/74F (U.L.) HIGH/LOW
$A_0 - A_2$	Output Select Address Inputs	0.5/0.375
$\bar{E}_1$	Chip Enable Input (Active LOW)	0.5/0.375
$E_2, E_3$	Chip Enable Inputs	0.5/0.375
LE	Latch Enable Input	0.5/0.375
$\bar{RD}$	Read Acknowledge Input (Active LOW)	0.5/0.375
$\bar{WR}$	Write Acknowledge Input (Active LOW)	0.5/0.375
$\bar{ACK}$	Open-collector Acknowledge Output (Active LOW)	OC*/12.5
$\bar{O}_0 - \bar{O}_7$	Decoded Outputs (Active LOW)	25/12.5

\*OC = Open Collector

## Logic Symbol



V<sub>CC</sub> = Pin 20  
GND = Pin 10

## Functional Description

When enabled, the 'F547 accepts the A<sub>0</sub>-A<sub>2</sub> Address inputs and decodes them to select one of eight active-LOW, mutually exclusive outputs, as shown in the Decoder Truth Table. With LE HIGH, the Address latches are transparent and the output selection changes each time the A<sub>0</sub>-A<sub>2</sub> address changes. When LE is LOW, the latches store the last valid address preceding the HIGH-to-LOW transition of the LE input signal. For applications in which the separation of latch enable and chip enable functions is not required, LE and  $\overline{E}_1$  can be tied together, such that when HIGH the outputs are OFF and the latches are transparent, and when LOW the latches are storing and the selected output is enabled.

The open-collector Acknowledge ( $\overline{ACK}$ ) output is normally HIGH (i.e. OFF) and goes LOW when  $\overline{E}_1$ , E<sub>2</sub> and E<sub>3</sub> are all active and either the Read ( $\overline{RD}$ ) or Write ( $\overline{WR}$ ) input is LOW, as indicated in the Acknowledge Truth Table.

## Decoder Truth Table\*

INPUTS			OUTPUTS							
A <sub>2</sub>	A <sub>1</sub>	A <sub>0</sub>	$\overline{O}_0$	$\overline{O}_1$	$\overline{O}_2$	$\overline{O}_3$	$\overline{O}_4$	$\overline{O}_5$	$\overline{O}_6$	$\overline{O}_7$
L	L	L	L	H	H	H	H	H	H	H
L	L	H	H	L	H	H	H	H	H	H
L	H	L	H	H	L	H	H	H	H	H
L	H	H	H	H	H	L	H	H	H	H
H	L	L	H	H	H	H	L	H	H	H
H	L	H	H	H	H	H	H	L	H	H
H	H	L	H	H	H	H	H	H	L	H
H	H	H	H	H	H	H	H	H	H	L

\*Assuming  $\overline{E}_1$ , LOW, E<sub>2</sub> and E<sub>3</sub> HIGH

## Latch and Output Status Table

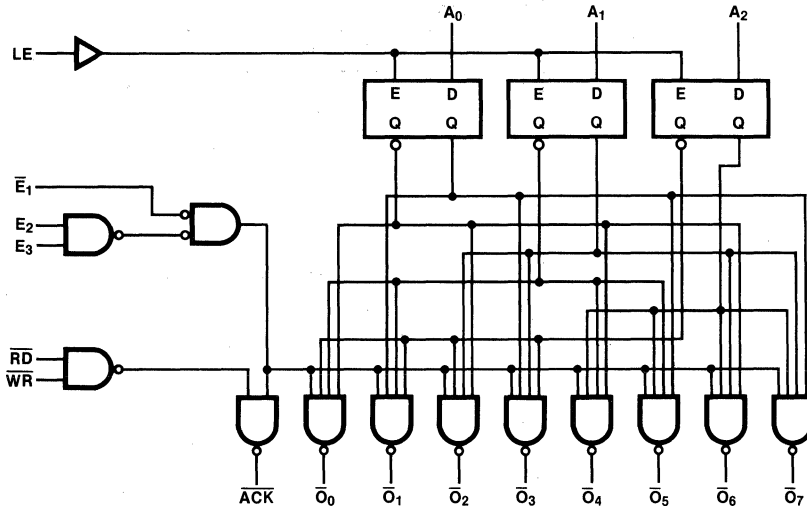
INPUTS				LATCH	DECODER
$\overline{E}_1$	E <sub>2</sub>	E <sub>3</sub>	LE	STATUS	OUTPUTS
X	X	X	H	Transparent	—
L	H	H	L	Storing	Selected Output LOW
H	X	X	X	Storing	All Outputs HIGH
X	L	X	X	Storing	All Outputs HIGH
X	X	L	X	Storing	All Outputs HIGH

## Acknowledge Truth Table

INPUTS					OUTPUT
$\overline{E}_1$	E <sub>2</sub>	E <sub>3</sub>	$\overline{RD}$	$\overline{WR}$	$\overline{ACK}$
H	X	X	X	X	H
X	L	X	X	X	H
X	X	L	X	X	H
L	H	H	H	H	H
L	H	H	L	X	L
L	H	H	X	L	L

H = HIGH Voltage Level  
L = LOW Voltage Level  
X = Immaterial

## Logic Diagram



### DC Characteristics over Operating Temperature Range (unless otherwise specified)

Symbol	Parameter	54F/74F			Units	Conditions
		Min	Typ	Max		
I <sub>CC</sub>	Power Supply Current		22	33	mA	V <sub>CC</sub> = Max

### AC Characteristics: See Section 3 for waveforms and load configurations

Symbol	Parameter	54F/74F			54F		74F		Units	Fig. No.
		T <sub>A</sub> = +25°C, V <sub>CC</sub> = +5.0 V, C <sub>L</sub> = 50 pF			T <sub>A</sub> , V <sub>CC</sub> = Mil, C <sub>L</sub> = 50 pF		T <sub>A</sub> , V <sub>CC</sub> = Com, C <sub>L</sub> = 50 pF			
		Min	Typ	Max	Min	Max	Min	Max		
t <sub>PLH</sub> t <sub>PHL</sub>	Propagation Delay A <sub>n</sub> to $\overline{O}_n$	3.0	5.5	8.0					ns	3-1 3-10
t <sub>PLH</sub> t <sub>PHL</sub>	Propagation Delay $\overline{E}_1$ to $\overline{O}_n$	3.0	5.5	8.0					ns	3-1 3-4
t <sub>PLH</sub> t <sub>PHL</sub>	Propagation Delay LE to $\overline{O}_n$	3.0	5.5	8.0					ns	3-1 3-3
t <sub>PLH</sub> t <sub>PHL</sub>	Propagation Delay E <sub>2</sub> or E <sub>3</sub> to $\overline{O}_n$	4.0	6.5	9.0					ns	3-1 3-3
t <sub>PLH</sub> t <sub>PHL</sub>	Propagation Delay $\overline{E}_1$ , RD or $\overline{WR}$ to $\overline{ACK}$	9.0	11.5	14					ns	3-1 3-4
t <sub>PLH</sub> t <sub>PHL</sub>	Propagation Delay E <sub>2</sub> or E <sub>3</sub> to $\overline{ACK}$	10	12.5	15					ns	3-1 3-3

■ Test limits in screened columns are preliminary.

**AC Operating Requirements:** See Section 3 for waveforms

Symbol	Parameter	54F/74F			54F		74F		Units	Fig. No.
		T <sub>A</sub> = +25°C, V <sub>CC</sub> = +5.0 V			T <sub>A</sub> , V <sub>CC</sub> = Mil		T <sub>A</sub> , V <sub>CC</sub> = Com			
		Min	Typ	Max	Min	Max	Min	Max		
t <sub>s</sub> (H) t <sub>s</sub> (L)	Setup Time, HIGH or LOW A <sub>n</sub> to LE	2.0							ns	3-15
t <sub>h</sub> (H) t <sub>h</sub> (L)	Hold Time, HIGH or LOW A <sub>n</sub> to LE	3.0								
t <sub>s</sub> (H) t <sub>s</sub> (L)	Setup Time, HIGH or LOW A <sub>n</sub> to $\overline{E}_1$	2.0							ns	3-14
t <sub>h</sub> (H) t <sub>h</sub> (L)	Hold Time, HIGH or LOW A <sub>n</sub> to $\overline{E}_1$	3.0								
t <sub>s</sub> (H) t <sub>s</sub> (L)	Setup Time, HIGH or LOW A <sub>n</sub> to E <sub>2</sub> , E <sub>3</sub>	4.0							ns	3-15
t <sub>h</sub> (H) t <sub>h</sub> (L)	Hold Time, HIGH or LOW A <sub>n</sub> to E <sub>2</sub> , E <sub>3</sub>	3.0								
t <sub>w</sub> (H)	LE Pulse Width HIGH	6.0							ns	3-7

■ Test limits in screened columns are preliminary.

## 54F/74F548

## Octal Decoder/Demultiplexer

(With Acknowledge)

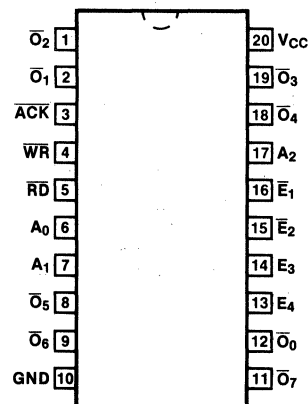
**Description**

The 'F548 is a 3-to-8 line address decoder with four Enable inputs. Two of the Enables are active LOW and two are active HIGH for maximum addressing versatility. Also provided is an active-LOW Acknowledge output that responds to either a Read or Write input signal when the Enables are active.

- 3-to-8 Line Address Decoder
- Multiple Enables for Address Extension
- Open-collector Acknowledge Output
- Active-LOW Decoder Outputs

**Ordering Code:** See Section 6

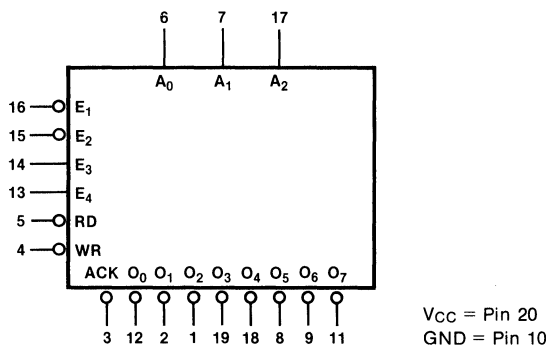
Pkg	Commercial Grade	Military Grade	Pkg Type
	V <sub>CC</sub> = +5.0 V ±5%, T <sub>A</sub> = 0° C to +70° C	V <sub>CC</sub> = +5.0 V ±10%, T <sub>A</sub> = -55° C to +125° C	
Plastic DIP (P)	74F548PC		9Z
Ceramic DIP (D)	74F548DC	54F548DM	4E
Flatpak (F)		54F548FM	4D

**Connection Diagram****Input Loading/Fan-Out:** See Section 3 for U.L. definitions

Pin Names	Description	54F/74F (U.L.) HIGH/LOW
A <sub>0</sub> - A <sub>2</sub>	Output Select Address Inputs	0.5/0.375
$\overline{E}_1$ , $\overline{E}_2$	Chip Enable Inputs (Active LOW)	0.5/0.375
E <sub>3</sub> , E <sub>4</sub>	Chip Enable Inputs	0.5/0.375
$\overline{RD}$	Read Acknowledge Input (Active LOW)	0.5/0.375
$\overline{WR}$	Write Acknowledge Input (Active LOW)	0.5/0.375
$\overline{ACK}$	Open-collector Acknowledge Output (Active LOW)	OC*/12.5
O <sub>0</sub> - O <sub>7</sub>	Decoded Outputs (Active LOW)	25/12.5

\*OC = Open Collector

## Logic Symbol



## Functional Description

When enabled, the 'F548 accepts the A<sub>0</sub>-A<sub>2</sub> Address inputs and decodes them to select one of eight active-LOW, mutually exclusive outputs, as shown in the Decoder Truth Table. When one or more Enables is inactive, all decoder outputs are HIGH. Thus, the 'F548 can be used as a demultiplexer by applying data to one of the Enables.

The open-collector Acknowledge ( $\overline{\text{ACK}}$ ) output is normally HIGH (i.e. OFF) and goes LOW when the Enables are all active and either the Read ( $\overline{\text{RD}}$ ) or Write ( $\overline{\text{WR}}$ ) input is LOW, as indicated in the Acknowledge Truth Table.

## Acknowledge Truth Table

INPUTS						OUTPUT
$\overline{\text{E}}_1$	$\overline{\text{E}}_2$	E <sub>3</sub>	E <sub>4</sub>	$\overline{\text{RD}}$	$\overline{\text{WR}}$	$\overline{\text{ACK}}$
H	X	X	X	X	X	H
X	H	X	X	X	X	H
X	X	L	X	X	X	H
X	X	X	L	X	X	H
L	L	H	H	H	H	H
L	L	H	H	L	X	L
L	L	H	H	X	L	L

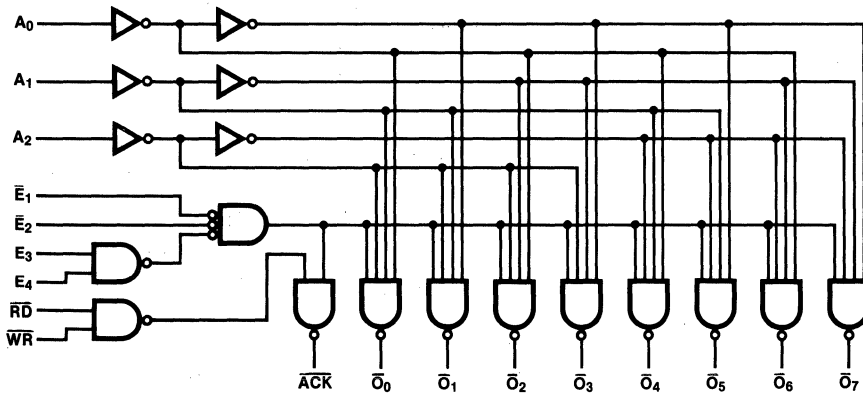
## Decoder Truth Table

INPUTS				OUTPUTS										
$\overline{\text{E}}_1$	$\overline{\text{E}}_2$	E <sub>3</sub>	E <sub>4</sub>	A <sub>2</sub>	A <sub>1</sub>	A <sub>0</sub>	$\overline{\text{O}}_0$	$\overline{\text{O}}_1$	$\overline{\text{O}}_2$	$\overline{\text{O}}_3$	$\overline{\text{O}}_4$	$\overline{\text{O}}_5$	$\overline{\text{O}}_6$	$\overline{\text{O}}_7$
H	X	X	X	X	X	X	H	H	H	H	H	H	H	H
X	H	X	X	X	X	X	H	H	H	H	H	H	H	H
X	X	L	X	X	X	X	H	H	H	H	H	H	H	H
X	X	X	L	X	X	X	H	H	H	H	H	H	H	H
L	L	H	H	L	L	L	L	H	H	H	H	H	H	H
L	L	H	H	L	L	H	H	L	H	H	H	H	H	H
L	L	H	H	L	H	L	H	H	L	H	H	H	H	H
L	L	H	H	L	H	H	H	H	L	H	H	H	H	H
L	L	H	H	H	L	L	H	H	H	L	H	H	H	H
L	L	H	H	H	L	H	H	H	H	H	L	H	H	H
L	L	H	H	H	H	L	H	H	H	H	H	L	H	H
L	L	H	H	H	H	H	H	H	H	H	H	H	L	H
L	L	H	H	H	H	H	H	H	H	H	H	H	H	L

H = HIGH Voltage Level L = LOW Voltage Level X = Immaterial



## Logic Diagram



## DC Characteristics over Operating Temperature Range (unless otherwise specified)

Symbol	Parameter	54F/74F			Units	Conditions
		Min	Typ	Max		
I <sub>CC</sub>	Power Supply Current		18	27	mA	V <sub>CC</sub> = Max

## AC Characteristics: See Section 3 for waveforms and load configurations

Symbol	Parameter	54F/74F			54F		74F		Units	Fig. No.
		T <sub>A</sub> = +25°C, V <sub>CC</sub> = +5.0 V C <sub>L</sub> = 50 pF			T <sub>A</sub> , V <sub>CC</sub> = Mil C <sub>L</sub> = 50 pF		T <sub>A</sub> , V <sub>CC</sub> = Com C <sub>L</sub> = 50 pF			
		Min	Typ	Max	Min	Max	Min	Max		
t <sub>PLH</sub> t <sub>PHL</sub>	Propagation Delay A <sub>n</sub> to $\overline{O}_n$	3.0 3.0	5.5 5.5	8.0 8.0				ns	3-1 3-10	
t <sub>PLH</sub> t <sub>PHL</sub>	Propagation Delay $\overline{E}_1$ or $\overline{E}_2$ to $\overline{O}_n$	3.0 3.0	5.5 5.5	8.0 8.0				ns	3-1 3-4	
t <sub>PLH</sub> t <sub>PHL</sub>	Propagation Delay E <sub>3</sub> or E <sub>4</sub> to $\overline{O}_n$	4.0 4.0	6.5 6.5	9.0 9.0				ns	3-1 3-3	
t <sub>PLH</sub> t <sub>PHL</sub>	Propagation Delay $\overline{E}_1$ or $\overline{E}_2$ to $\overline{ACK}$	9.0 3.0	11.5 5.5	14 8.0				ns	3-1 3-4	
t <sub>PLH</sub> t <sub>PHL</sub>	Propagation Delay E <sub>3</sub> or E <sub>4</sub> to $\overline{ACK}$	10 4.0	12.5 6.5	15 9.0				ns	3-1 3-3	
t <sub>PLH</sub> t <sub>PHL</sub>	Propagation Delay RD or WR to $\overline{ACK}$	9.0 3.0	11.5 5.5	14 8.0				ns	3-1 3-4	

■ Test limits in screened columns are preliminary.

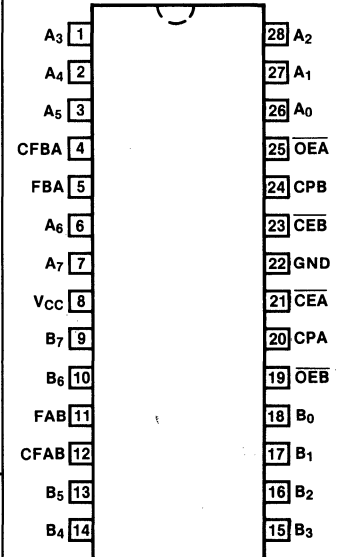
**54F/74F550 • 54F/74F551****Octal Registered Transceiver**  
(With Status Flags)**Description**

The 'F550 and 'F551 octal transceivers each contain two 8-bit registers for temporary storage of data flowing in either direction. Each register has its own clock pulse and clock enable inputs, as well as a flag flip-flop that is set automatically as the register is loaded. Each flag flip-flop is provided with a clear input, and each register has a separate output enable control for its 3-state buffers. The separate clocks, flags and enables provide considerable flexibility as I/O ports for demand-response data transfer. The 'F550 is non-inverting; the 'F551 inverts data in both directions.

- **8-Bit Bidirectional I/O Port with Handshake**
- **Back-to-Back Registers for Storage**
- **Register Status Flag Flip-Flops**
- **Separate Edge-detecting Clears for Flags**
- **Inverting and Non-Inverting Versions**
- **A Outputs Sink 20 mA, B Outputs Sink 64 mA**

**Ordering Code:** See Section 6

Pkgs	Commercial Grade	Military Grade	Pkg Type
	V <sub>CC</sub> = +5.0 V ±5%, T <sub>A</sub> = 0° C to +70° C	V <sub>CC</sub> = +5.0 V ±10%, T <sub>A</sub> = -55° C to +125° C	
Plastic DIP (P)	74F550PC, 74F551PC		9Y
Ceramic DIP (D)	74F550DC, 74F551DC	54F550DM, 54F551DM	8S
Flatpak (F)		54F550FM, 54F551FM	2E

**Connection Diagram**  
( 'F550 shown\*)

\*'F551 has inverting outputs

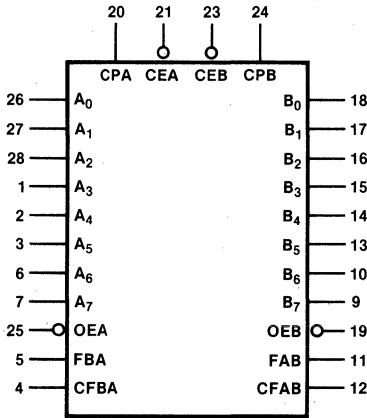
4

**Input Loading/Fan-Out:** See Section 3 for U.L. definitions

Pin Names	Description	54F/74F (U.L.) HIGH/LOW
CPA	A-to-B Clock Pulse Input (Active Rising Edge)	0.5/0.375
CPB	B-to-A Clock Pulse Input (Active Rising Edge)	0.5/0.375
CEA	A-to-B Clock Enable Input (Active LOW)	0.5/0.375
CEB	B-to-A Clock Enable Input (Active LOW)	0.5/0.375
OEA	A Output Enable Input (Active LOW)	0.5/0.375
OEB	B Output Enable Input (Active LOW)	0.5/0.375
CFAB	A-to-B Flag Clear Input (Active Rising Edge)	0.5/0.5
CFBA	B-to-A Flag Clear Input (Active Rising Edge)	0.5/0.5
A <sub>0</sub> - A <sub>7</sub>	A-to-B Data Inputs or 3-State B-to-A Outputs	1.75/0.375 25/12.5
B <sub>0</sub> - B <sub>7</sub>	B-to-A Data Inputs or 3-State A-to-B Outputs	1.75/0.375 25/40 (30)
FAB	A-to-B Status Flag Output (Active HIGH)	0.5/0.375
FBA	B-to-A Status Flag Output (Active HIGH)	0.5/0.375

## Logic Symbols

'F550

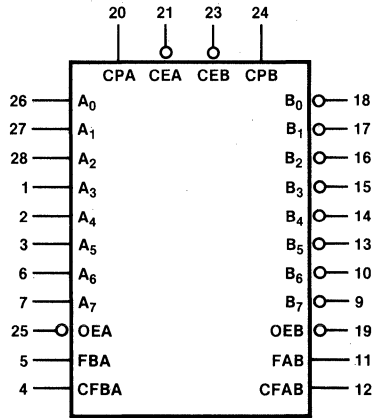


V<sub>CC</sub> = Pin 8  
GND = Pin 22

### Functional Description

Data applied to the A inputs is entered and stored on the rising edge of the A Clock Pulse (CPA), provided that the A Clock Enable ( $\overline{\text{CEA}}$ ) is LOW; simultaneously, the status flip-flop is set and the A-to-B flag (FAB) output goes HIGH. Data thus entered from the A inputs is present at the inputs to the B output buffers, but only appears on the B I/O pins when the B Output Enable ( $\overline{\text{OEB}}$ ) signal is made LOW. After the B output data is assimilated, the receiving system clears the A-to-B flag flip-flop by applying a LOW-to-

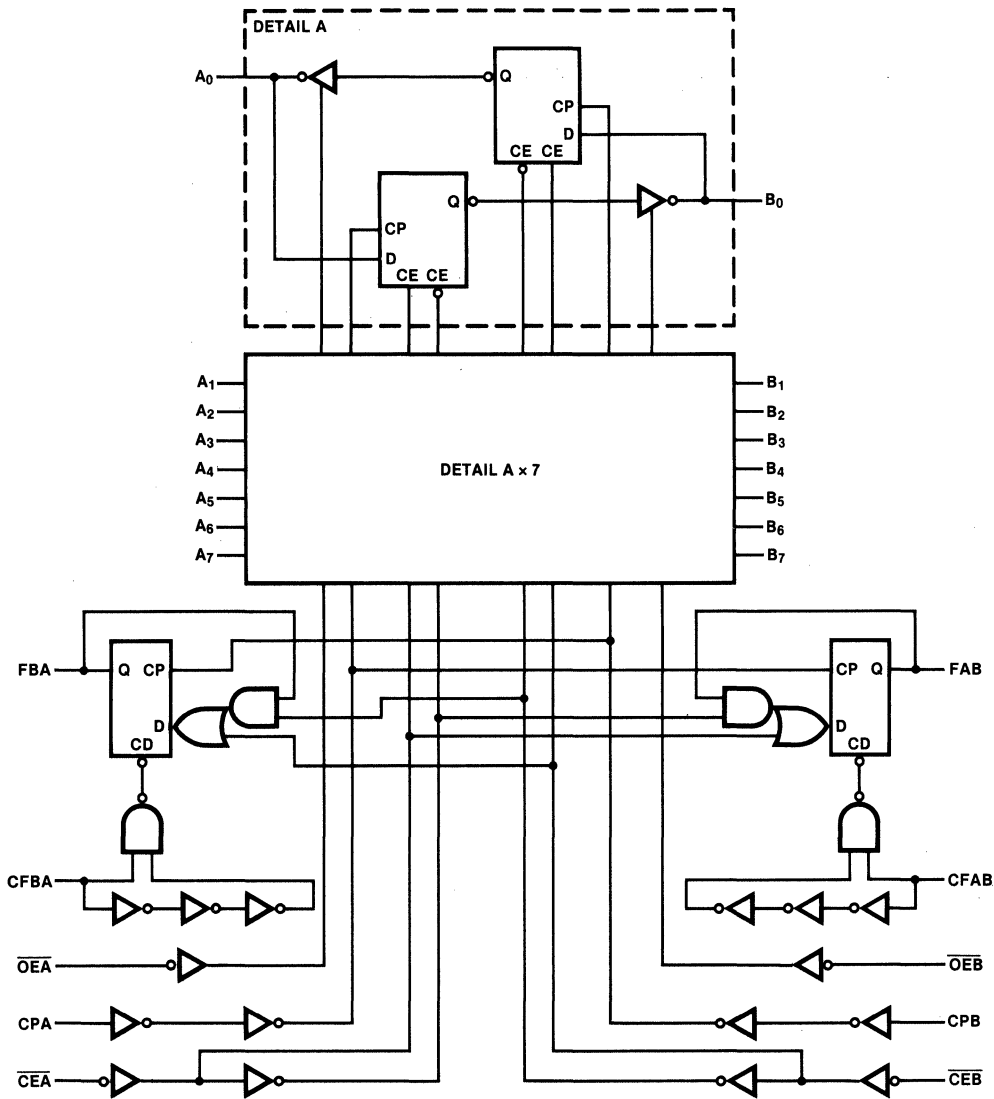
'F551



HIGH transition to the CFAB input. Optionally, the  $\overline{\text{OEA}}$  and CFAB pins can be tied together and operated by one function from the receiving system.

Data flow from B-to-A proceeds in the same manner described for A-to-B flow. Inputs  $\overline{\text{CEB}}$  and CPB enter the B input data and set the B-to-A flag (FBA) output HIGH. A LOW signal on  $\overline{\text{OEA}}$  enables the A output buffers and a LOW-to-HIGH transition on CFBA clears the FBA flag.

Logic Diagram ('F550 shown)



## DC Characteristics over Operating Temperature Range (unless otherwise specified)

Symbol	Parameter		54F/74F			Units	Conditions
			Min	Typ	Max		
V <sub>OH</sub>	Output HIGH Voltage B <sub>0</sub> - B <sub>7</sub>	XM	2.0			V	I <sub>OH</sub> = -12 mA
		XC					I <sub>OH</sub> = -15 mA
V <sub>OH</sub>	Output HIGH Voltage A <sub>n</sub> , B <sub>n</sub>		2.4			V	I <sub>OH</sub> = -3.0 mA
V <sub>OL</sub>	Output LOW Voltage B <sub>0</sub> - B <sub>7</sub>	XM			0.55	V	I <sub>OL</sub> = 48 mA
		XC					I <sub>OL</sub> = 64 mA
I <sub>IH</sub>	Input HIGH Current Breakdown Test — A <sub>n</sub> , B <sub>n</sub>				100	μA	V <sub>IN</sub> = 5.5V
I <sub>IH</sub> + I <sub>OZH</sub>	3-State Output OFF Current HIGH — A <sub>n</sub> , B <sub>n</sub>				70	μA	V <sub>CC</sub> = Max, V <sub>OUT</sub> = 2.7 V
I <sub>IL</sub> + I <sub>OZL</sub>	3-State Output OFF Current LOW — A <sub>n</sub> , B <sub>n</sub>				0.6	mA	V <sub>CC</sub> = Max, V <sub>OUT</sub> = 0.5 V
I <sub>OS</sub>	Output Short-circuit Current B <sub>0</sub> - B <sub>7</sub>		-100		-225	mA	V <sub>CC</sub> = Max
I <sub>CC</sub>	Power Supply Current			130	190	mA	V <sub>CC</sub> = Max

**AC Characteristics:** See Section 3 for waveforms and load configurations

Symbol	Parameter	54F/74F			54F		74F		Units	Fig. No.
		T <sub>A</sub> = +25°C, V <sub>CC</sub> = +5.0 V C <sub>L</sub> = 50 pF			T <sub>A</sub> , V <sub>CC</sub> = Mil C <sub>L</sub> = 50 pF		T <sub>A</sub> , V <sub>CC</sub> = Com C <sub>L</sub> = 50 pF			
		Min	Typ	Max	Min	Max	Min	Max		
t <sub>PLH</sub> t <sub>PHL</sub>	Propagation Delay CPA, CPB to B <sub>n</sub> , A <sub>n</sub>	6.5	11	15.5				ns	3-1 3-7	
t <sub>PLH</sub> t <sub>PHL</sub>	Propagation Delay CPA, CPB to FAB, FBA	4.0	7.0	10				ns	3-1 3-7	
t <sub>PLH</sub> t <sub>PHL</sub>	Propagation Delay CFAB, CFBA to FAB, FBA	5.5	9.0	12.5				ns	3-1 3-11	
t <sub>PZH</sub> t <sub>PZL</sub>	Output Enable Time $\overline{OE}A$ or $\overline{OE}B$ to A <sub>n</sub> or B <sub>n</sub>	6.0	10	14				ns	3-1 3-12 3-13	
t <sub>PHZ</sub> t <sub>PLZ</sub>	Output Disable Time $\overline{OE}A$ or $\overline{OE}B$ to A <sub>n</sub> or B <sub>n</sub>	6.0	10	14						
		6.0	10	14						

4

**AC Operating Requirements:** See Section 3 for waveforms

Symbol	Parameter	54F/74F			54F		74F		Units	Fig. No.
		T <sub>A</sub> = +25°C, V <sub>CC</sub> = +5.0 V			T <sub>A</sub> , V <sub>CC</sub> = Mil		T <sub>A</sub> , V <sub>CC</sub> = Com			
		Min	Typ	Max	Min	Max	Min	Max		
t <sub>s</sub> (H) t <sub>s</sub> (L)	Setup Time, HIGH or LOW A <sub>n</sub> , B <sub>n</sub> to CPA, CPB	5.0						ns	3-5	
t <sub>h</sub> (H) t <sub>h</sub> (L)	Hold Time, HIGH or LOW A <sub>n</sub> , B <sub>n</sub> to CPA, CPB	0								
t <sub>s</sub> (H) t <sub>s</sub> (L)	Setup Time, HIGH OR LOW $\overline{CE}A$ , $\overline{CE}B$ to CPA, CPB	8.0						ns	3-5	
t <sub>h</sub> (H) t <sub>h</sub> (L)	Hold Time, HIGH or LOW $\overline{CE}A$ or $\overline{CE}B$ to CPA or CPB	0								
t <sub>w</sub> (H) t <sub>w</sub> (L)	Pulse Width, HIGH or LOW CPA or CPB	8.0						ns	3-7	
t <sub>w</sub> (H)	Pulse Width HIGH CFAB or CFBA	8.0						ns	3-11	
t <sub>rec</sub>	Recovery Time CFAB, CFBA to CPA, CPB	15						ns	3-11	

■ Test limits in screened columns are preliminary.

# 54F/74F557 • 54F/74F558

## 8-Bit By 8-Bit Multipliers

(With 3-State Outputs)

### Description

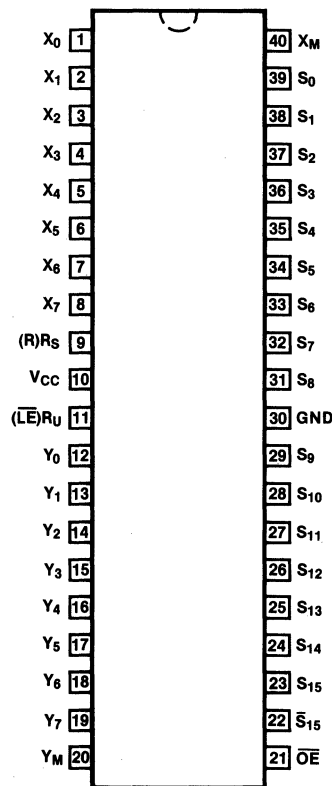
The 'F557 and 'F558 are high-speed combinatorial arrays that multiply two 8-bit unsigned or signed twos complement numbers and provide the 16-bit unsigned or signed product. Each input operand X and Y has a mode control input that determines whether the number is treated as signed or unsigned. Additional inputs,  $R_S$  and  $R_U$  for the 'F558 or R for the 'F557, allow the addition of a bit for rounding to the best signed or unsigned fractional 8-bit result. For expansion during signed or mixed multiplication, both the true and complement outputs of the most significant bit are available. The 'F557 has output latches that store the results when  $\overline{LE}$  is HIGH. Both devices have 3-state outputs for bus applications.

- **Unsigned, Signed or Mixed Multiplication**
- **Full 16-Bit Product Outputs**
- **MSB Complement Output for Signed Expansion**
- **Rounding Inputs for Fractional 8-Bit Product**

**Ordering Code:** See Section 6

Pkg	Commercial Grade	Military Grade	Pkg Type
	$V_{CC} = +5.0\text{ V} \pm 5\%$ , $T_A = 0^\circ\text{ C to } +70^\circ\text{ C}$	$V_{CC} = +5.0\text{ V} \pm 10\%$ , $T_A = -55^\circ\text{ C to } +125^\circ\text{ C}$	
Plastic DIP (P)	74F557PC, 74F558PC		9L
Ceramic DIP (D)	74F557DC, 74F558DC	54F557DM, 54F558DM	4W

### Connection Diagram

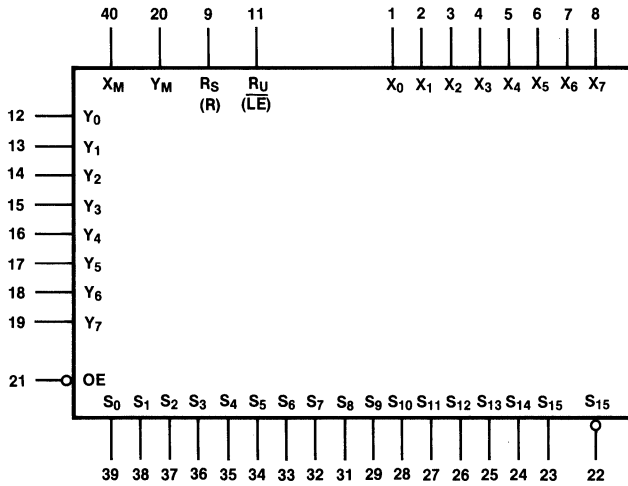


Pin assignments shown are for 'F558.  $\overline{LE}$  and R shown in parentheses are pin assignments for 'F557.

**Input Loading/Fan-Out:** See Section 3 for U.L. definitions

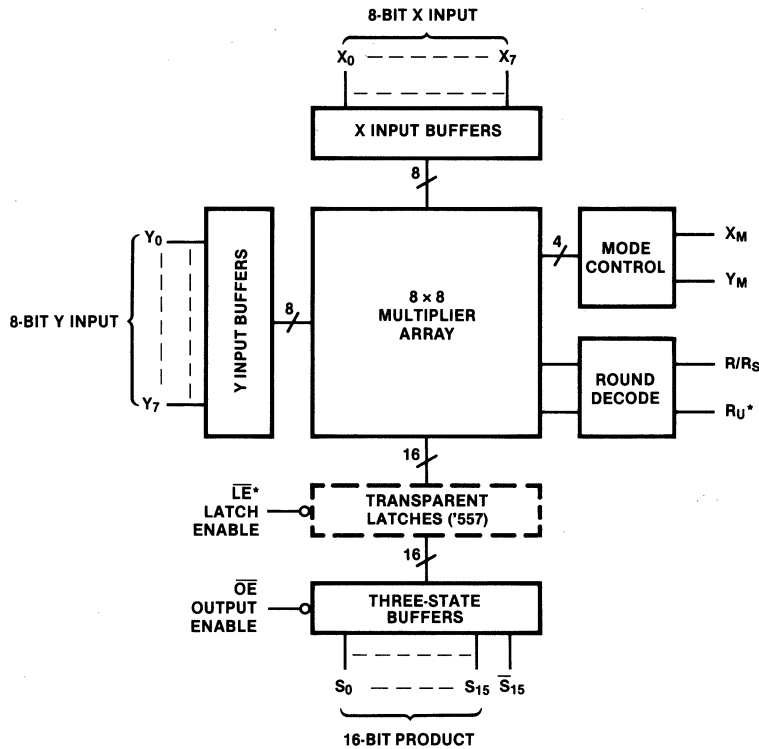
Pin Names	Description	54F/74F (U.L.) HIGH/LOW
$X_0 - X_7$	Multiplicand Inputs	0.5/0.5
$Y_0 - Y_7$	Multiplier Inputs	0.5/0.5
$X_M$	Multiplicand Sign Control Input	0.5/0.5
$Y_M$	Multiplier Sign Control Input	0.5/0.5
R	Rounding Input ('F557)	0.5/0.5
$R_S$	Signed Number Rounding Input ('F558)	0.5/0.5
$R_U$	Unsigned Number Rounding Input ('F558)	0.5/0.5
$\overline{LE}$	Latch Enable Input (Active LOW) ('F557)	0.5/0.5
$\overline{OE}$	3-State Output Enable Input (Active LOW)	0.5/0.5
$S_0 - S_{15}$	Product Outputs	50/12.5
$\overline{S}_{15}$	MSB Complement Output	50/12.5

Logic Symbol



V<sub>CC</sub> = Pin 10  
GND = Pin 30

Logic Diagram



\*Pin 11 is LE for 'F557 and R<sub>U</sub> for 'F558.



Mode Select Table

OPERATING MODE	INPUT DATA		MODE CONTROL INPUTS	
	X <sub>0</sub> -X <sub>7</sub>	Y <sub>0</sub> -Y <sub>7</sub>	X <sub>M</sub>	Y <sub>M</sub>
Unsigned	Unsigned	Unsigned	L	L
Mixed	Unsigned	Twos Complement	L	H
	Twos Complement	Unsigned	H	L
Signed	Twos Complement	Twos Complement	H	H

H = HIGH Voltage Level  
 L = LOW Voltage Level  
 X = Immaterial

**Functional Description**

The 'F557 and 'F558 multipliers are 8 x 8 combinatorial logic arrays capable of multiplying numbers in unsigned, signed twos complement or mixed notation. Each 8-bit input operand X and Y has an associated mode control which determines whether the array treats the number as signed or unsigned. If the mode control X<sub>M</sub> or Y<sub>M</sub> is HIGH, the operand is treated as a twos complement number with the most significant bit having a negative weight; if the mode control is LOW, the operand is treated as an unsigned number.

The multipliers provide all 16 product bits generated by the multiplication. For expansion during signed or mixed multiplication, the most significant product bit has both true and complement available. Therefore, an adder may be used as a subtractor in many applications and the need for SSI circuits is eliminated.

The 'F557 has latches that store the product for pipelined operations. When  $\overline{LE}$  is LOW the latches are transparent and their outputs change with their inputs. When  $\overline{LE}$  is HIGH the latches are in the storage mode and new data cannot enter.

The 3-state output buffers are controlled by the active-LOW Output Enable  $\overline{OE}$  input. When  $\overline{OE}$  is LOW, the outputs are active; when  $\overline{OE}$  is HIGH, the outputs are in a high impedance (high-Z) state. Several multipliers can be connected on a common bus or used in a pipeline system for multiplications in higher speed systems.

**Rounding**

The 16-bit product can be truncated to eight bits by using the rounding input(s) to add one in either the 27 adder for unsigned numbers or in the 26 adder for signed numbers. The 'F558 has separate rounding

inputs R<sub>S</sub> and R<sub>U</sub> for signed or unsigned numbers, respectively. The 'F557 has a single rounding input R and develops the proper rounding by internally combining R with X<sub>M</sub> and Y<sub>M</sub> as follows:

$$R_U = \overline{X_M} \cdot \overline{Y_M} \cdot R = \text{unsigned rounding input to 27 adder}$$

$$R_S = (X_M \pm Y_M)R = \text{signed rounding input to 26 adder}$$

Rounding input levels and results for the various modes are shown in Tables 1 and 2. Figure a shows how R<sub>S</sub> and R<sub>U</sub> would normally be used for rounding signed and unsigned fractional multipliers.

Table 1 'F557 Rounding Inputs

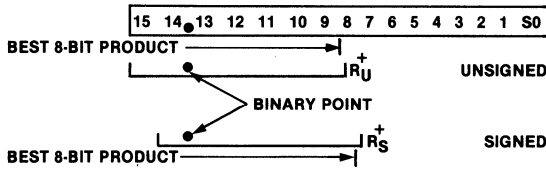
INPUTS			ADDS	
X <sub>M</sub>	Y <sub>M</sub>	R	27	26
L	L	H	Yes	No
L	H	H	No	Yes
H	L	H	No	Yes
H	H	H	No	Yes
X	X	L	No	No

Table 2 'F558 Rounding Inputs

INPUTS		ADDS		Normally Used With	
R <sub>U</sub>	R <sub>S</sub>	27	26	X <sub>M</sub>	Y <sub>M</sub>
L	L	No	No	X	X
L	H	No	Yes	X <sub>M</sub> + Y <sub>M</sub>	H
H	L	Yes	No	L	L
H	H	Yes	Yes	*	*

\* Most rounding applications require a HIGH level for R<sub>U</sub> or R<sub>S</sub>, but not both.

Fig. a Rounded Products



must be a positive sum and a negative carry (borrow). The equations are:

$$S = A + B + C$$

$$C_0 = A \cdot B + B \cdot \overline{C} + \overline{C} \cdot A$$

where C is the Carry In and A and B the sign bits of the two partial products.

An adder produces the equations:

$$S = A + B + C$$

$$C_0 = A \cdot B + B \cdot C + C \cdot A$$

Therefore, if the inversion of A and B is used, then the adder produces the inversion of the negative carry since

$$A \cdot B + B \cdot \overline{C} + \overline{C} \cdot A = \overline{A} \cdot \overline{B} + \overline{B} \cdot C + \overline{A} \cdot C$$

and the sum remains the same.

**Signed Expansion**

The most significant product bit has both true and complement outputs available. When building larger signed multipliers the partial products, except at the lower stages, are signed numbers. These unsigned and signed partial products must be added to give the correct signed product. For example, to obtain the correct signed product when using MSI adders the "carry" from the previous adder stage must be added to the sum of the two negative most significant partial product bits. The result of this addition

**DC Characteristics over Operating Temperature Range** (unless otherwise specified)

Symbol	Parameter	54F/74F			Units	Conditions
		Min	Typ	Max		
I <sub>CC</sub>	Power Supply Current		200	280	mA	V <sub>CC</sub> = Max

**AC Characteristics:** See Section 3 for waveforms and load configurations

Symbol	Parameter	54F/74F			54F		74F		Units	Fig. No.
		T <sub>A</sub> = +25°C, V <sub>CC</sub> = +5.0 V, C <sub>L</sub> = 50 pF			T <sub>A</sub> , V <sub>CC</sub> = Mil, C <sub>L</sub> = 50 pF		T <sub>A</sub> , V <sub>CC</sub> = Com, C <sub>L</sub> = 50 pF			
		Min	Typ	Max	Min	Max	Min	Max		
t <sub>PLH</sub>	Propagation Delay X <sub>n</sub> or Y <sub>n</sub> to S <sub>n</sub> , $\overline{S}_{15}$		45	70					ns	3-1
t <sub>PHL</sub>			45	70						3-10
t <sub>PLH</sub>	Propagation Delay $\overline{LE}$ to S <sub>n</sub> , $\overline{S}_{15}$ ('F557)		20						ns	3-1
t <sub>PHL</sub>			20							3-8
t <sub>PZH</sub>	Output Enable Time $\overline{OE}$ to S <sub>n</sub> or $\overline{S}_{15}$	6.0	10	14					ns	3-1
t <sub>PZL</sub>		6.0	10	14						
t <sub>PHZ</sub>	Output Disable Time $\overline{OE}$ to S <sub>n</sub> or $\overline{S}_{15}$	9.0	15	21						
t <sub>PLZ</sub>		6.0	10	14						3-12
										3-13

■ Test limits in screened columns are preliminary.

AC Operating Requirements ('F557 Only): See Section 3 for waveforms

Symbol	Parameter	54F/74F			54F		74F		Units	Fig. No.
		T <sub>A</sub> = +25°C, V <sub>CC</sub> = +5.0 V			T <sub>A</sub> , V <sub>CC</sub> = Mil		T <sub>A</sub> , V <sub>CC</sub> = Com			
		Min	Typ	Max	Min	Max	Min	Max		
t <sub>s</sub> (H) t <sub>s</sub> (L)	Setup Time, HIGH or LOW, X <sub>n</sub> or Y <sub>n</sub> to $\overline{LE}$	65						ns	3-14	
t <sub>h</sub> (H) t <sub>h</sub> (L)	Hold Time, HIGH or LOW, X <sub>n</sub> or Y <sub>n</sub> to $\overline{LE}$	0								
t <sub>w</sub> (L)	$\overline{LE}$ Pulse Width LOW	10						ns	3-8	

■ Test limits in screened columns are preliminary.

**Applications**

**16 x 16 Twos Complement Multiplier**

The 'F558 8 x 8 multiplier can be used with standard MSI adder circuits to build larger multipliers.

Figure b illustrates the use of four 'F558 multipliers and ten 16-pin 4-bit 54F/74F283 adders to form a 16 x 16-bit twos complement multiplier with a typical multiplication time of 90 ns. The 16-bit operands are split up into 8-bit sections:

$$\begin{aligned}
 X \cdot Y &= (X_{0-7} + X_{8-15}2^8) \cdot (Y_{0-7} + Y_{8-15}2^8) \\
 &= X_{0-7} \cdot Y_{0-7} + 2^8 (X_{0-7} \cdot Y_{8-15} + X_{8-15} \cdot Y_{0-7}) + \\
 &\quad + 2^{16} (X_{8-15} \cdot Y_{8-15})
 \end{aligned}$$

Since X<sub>8</sub> - X<sub>15</sub> and Y<sub>8</sub> - Y<sub>15</sub> are signed numbers, the most significant bit of all the partial products (except

the first) carries a negative weight. Therefore, at these negative bit positions the partial product bits must be subtracted rather than added. This subtraction is done in the middle of the network at the 2<sup>15</sup> bit position by using the inverted output of the most significant product bits from the multipliers to obtain a 'borrow' signal from the last sum output of the appropriate 'F283. This 'borrow' is then used to either add zero or minus 1 to the remaining 8-bit adder section. The mode control inputs of the four 'F558 devices are tied to the logic levels required to produce the correctly signed partial products. Rounding to the best 16-bit fractional product is made by tying the R<sub>S</sub> input of one of the middle multipliers to V<sub>CC</sub>. Appropriate connection of the adders and mode control logic levels will yield 16 x 16 unsigned multiplication.



# 54F/74F568 • 54F/74F569

## 4-Bit Bidirectional Counters

(With 3-State Outputs)

### Description

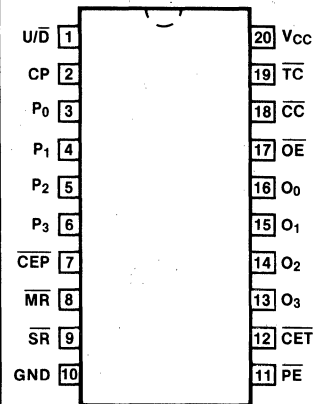
The 'F568 and 'F569 are fully synchronous, reversible counters with 3-state outputs. The 'F568 is a BCD decade counter; the 'F569 is a binary counter. They feature preset capability for programmable operation, carry lookahead for easy cascading, and a  $U/\overline{D}$  input to control the direction of counting. For maximum flexibility there are both synchronous and master asynchronous reset inputs as well as both Clocked Carry ( $\overline{CC}$ ) and Terminal Count ( $\overline{TC}$ ) outputs. All state changes except Master Reset are initiated by the rising edge of the clock. A HIGH signal on the Output Enable ( $\overline{OE}$ ) input forces the output buffers into the high-impedance state but does not prevent counting, resetting or parallel loading.

- Synchronous Counting and Loading
- Lookahead Carry Capability for Easy Cascading
- Preset Capability for Programmable Operation
- 3-State Outputs for Bus Organized Systems

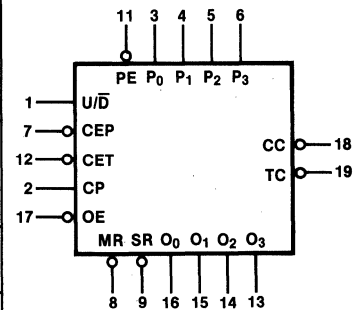
Ordering Code: See Section 6

Pkg	Commercial Grade	Military Grade	Pkg Type
	$V_{CC} = +5.0\text{ V} \pm 5\%$ , $T_A = 0^\circ\text{C to } +70^\circ\text{C}$	$V_{CC} = +5.0\text{ V} \pm 10\%$ , $T_A = -55^\circ\text{C to } +125^\circ\text{C}$	
Plastic DIP (P)	74F568PC, 74F569PC		9Z
Ceramic DIP (D)	74F568DC, 74F569DC	54F568DM, 54F569DM	4E
Flatpak (F)		54F568FM, 54F569FM	4D

### Connection Diagram



### Logic Symbol



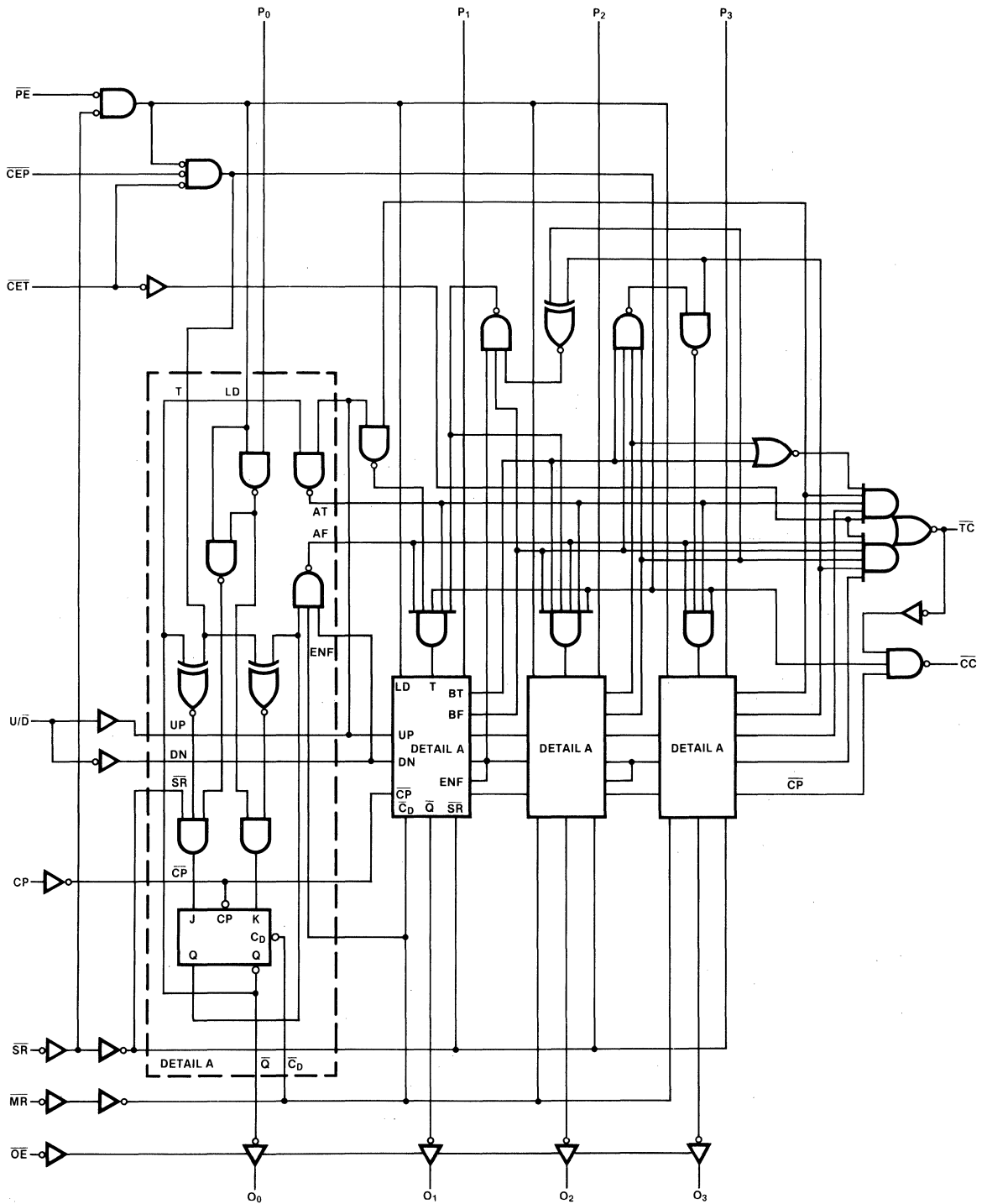
$V_{CC} = \text{Pin } 20$   
 $GND = \text{Pin } 10$

Input Loading/Fan-Out: See Section 3 for U.L. definitions

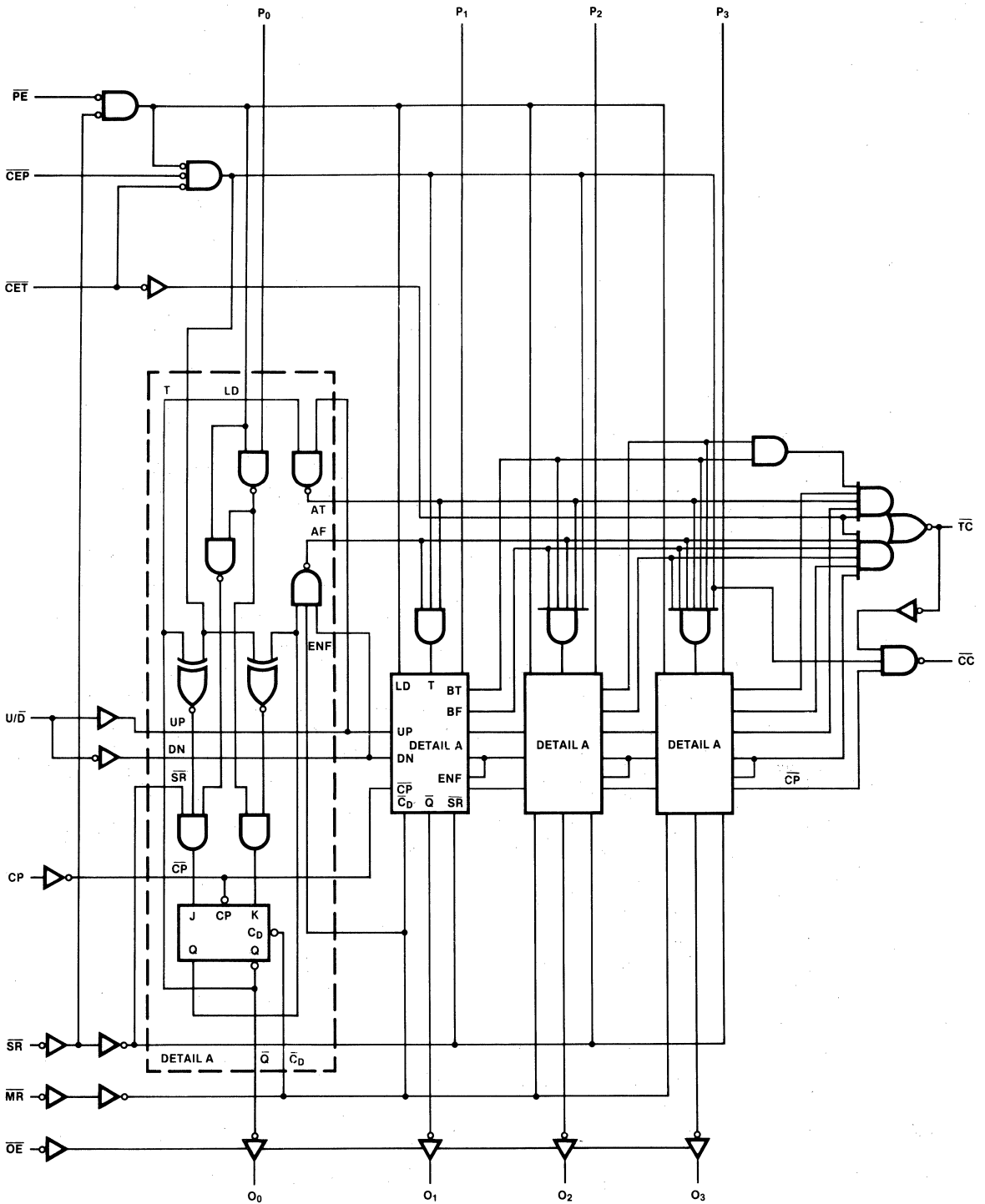
Pin Names	Description	54F/74F (U.L.) HIGH/LOW
$P_0 - P_3$	Parallel Data Inputs	0.5/0.375
$\overline{CEP}$	Count Enable Parallel Input (Active LOW)	0.5/0.375
$\overline{CET}$	Count Enable Trickle Input (Active LOW)	0.5/0.75
CP	Clock Pulse Input (Active Rising Edge)	0.5/0.375
$\overline{PE}$	Parallel Enable Input (Active LOW)	0.5/0.375
$U/\overline{D}$	Up/Down Count Control Input	0.5/0.375
$\overline{OE}$	Output Enable Input (Active LOW)	0.5/0.375
$\overline{MR}$	Master Reset Input (Active LOW)	0.5/0.375
$\overline{SR}$	Synchronous Reset Input (Active LOW)	0.5/0.375
$O_0 - O_3$	3-State Parallel Data Outputs	25/12.5
$\overline{TC}$	Terminal Count Output (Active LOW)	25/12.5
$\overline{CC}$	Clocked Carry Output (Active LOW)	25/12.5

Logic Diagrams

'F568

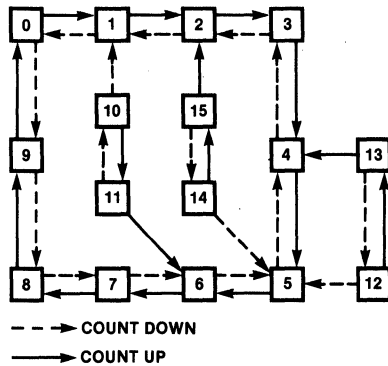


'F569

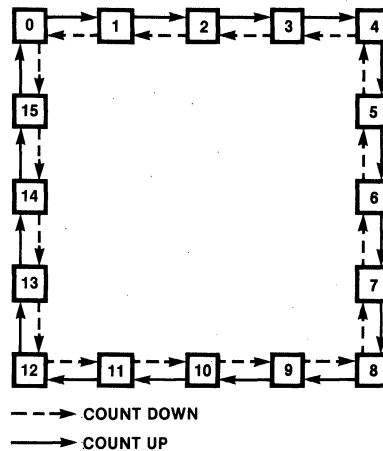


## State Diagrams

'F568



'F569



## Functional Description

The 'F568 counts modulo-10 in the BCD (8421) sequence. From state 9 (HLLH) it will increment to 0 (LLLL) in the Up mode; in Down mode it will decrement from 0 to 9. The 'F569 counts in the modulo-16 binary sequence. From state 15 it will increment to state 0 in the Up mode; in the Down mode it will decrement from 0 to 15. The clock inputs of all flip-flops are driven in parallel through a clock buffer. All state changes (except due to Master Reset) occur synchronously with the LOW-to-HIGH transition of the Clock Pulse (CP) input signal.

The circuits have five fundamental modes of operation, in order of precedence: asynchronous reset, synchronous reset, parallel load, count and hold. Five control inputs — Master Reset ( $\overline{MR}$ ), Synchronous Reset ( $\overline{SR}$ ), Parallel Enable ( $\overline{PE}$ ), Count Enable Parallel ( $\overline{CEP}$ ) and Count Enable Trickle ( $\overline{CET}$ ) — plus the Up/Down (U/D) input, determine the mode of operation, as shown in the Mode Select

Table. A LOW signal on  $\overline{MR}$  overrides all other inputs and asynchronously forces the flip-flop Q outputs LOW. A LOW signal on  $\overline{SR}$  overrides counting and parallel loading and allows the Q outputs to go LOW on the next rising edge of CP. A LOW signal on  $\overline{PE}$  overrides counting and allows information on the Parallel Data (Pn) inputs to be loaded into the flip-flops on the next rising edge of CP. With  $\overline{MR}$ ,  $\overline{SR}$  and  $\overline{PE}$  HIGH,  $\overline{CEP}$  and  $\overline{CET}$  permit counting when both are LOW. Conversely, a HIGH signal on either  $\overline{CEP}$  or  $\overline{CET}$  inhibits counting.

The 'F568 and 'F569 use edge-triggered flip-flops and changing the  $\overline{SR}$ ,  $\overline{PE}$ ,  $\overline{CEP}$ ,  $\overline{CET}$  or U/D inputs when the CP is in either state does not cause errors, provided that the recommended setup and hold times, with respect to the rising edge of CP, are observed.

Two types of outputs are provided as overflow/underflow indicators. The Terminal Count ( $\overline{TC}$ )

Mode Select Table

INPUTS						OPERATING MODE
$\overline{MR}$	$\overline{SR}$	$\overline{PE}$	$\overline{CEP}$	$\overline{CET}$	U/D	
L	X	X	X	X	X	Asynchronous Reset
H	L	X	X	X	X	Synchronous Reset
H	H	L	X	X	X	Parallel Load
H	H	H	H	X	X	Hold
H	H	H	X	H	X	Hold
H	H	H	L	L	H	Count Up
H	H	H	L	L	L	Count Down



H = HIGH Voltage Level  
L = LOW Voltage Level  
X = Immaterial



output is normally HIGH and goes LOW providing  $\overline{CET}$  is LOW, when the counter reaches zero in the Down mode, or reaches maximum (9 for the 'F568, 15 for the 'F569) in the Up mode.  $\overline{TC}$  will then remain LOW until a state change occurs, whether by counting or presetting, or until  $U/\overline{D}$  or  $\overline{CET}$  is changed. To implement synchronous multistage counters, the connections between the  $\overline{TC}$  output and the  $\overline{CEP}$  and  $\overline{CET}$  inputs can provide either slow or fast carry propagation. Figure a shows the connections for simple ripple carry, in which the clock period must be longer than the CP to  $\overline{TC}$  delay of the first stage, plus the cumulative  $\overline{CET}$  to  $\overline{TC}$  delays of the intermediate stages, plus the  $\overline{CET}$  to CP setup time of the last stage. For faster clock rates, the carry lookahead connections shown in Figure b are recommended. In this scheme the ripple delay through the intermediate stages commences with the same clock that causes the first stage to tick over from max to min in the Up

mode, or min to max in the Down mode, to start its final cycle. Since this final cycle takes 10 ('F568) or 16 ('F569) clocks to complete, there is plenty of time for the ripple to progress through the intermediate stages. The critical timing that limits the clock period is the CP to  $\overline{TC}$  delay of the first stage plus the  $\overline{CEP}$  to CP setup time of the last stage. The  $\overline{TC}$  output is subject to decoding spikes due to internal race conditions and is therefore not recommended for use as a clock or asynchronous reset for flip-flops, registers or counters. For such applications, the Clocked Carry ( $\overline{CC}$ ) output is provided. The  $\overline{CC}$  output is normally HIGH. When  $\overline{CEP}$ ,  $\overline{CET}$  and  $\overline{TC}$  are LOW, the  $\overline{CC}$  output will go LOW when the clock next goes LOW and will stay LOW until the clock goes HIGH again, as shown in the  $\overline{CC}$  Truth Table. When the Output Enable ( $\overline{OE}$ ) is LOW, the parallel data outputs  $O_0 - O_3$  are active and follow the flip-flop Q outputs. A HIGH signal on  $\overline{OE}$  forces  $O_0 - O_3$  to the high-Z state but does not prevent counting, loading or resetting.

**$\overline{CC}$  Truth Table**

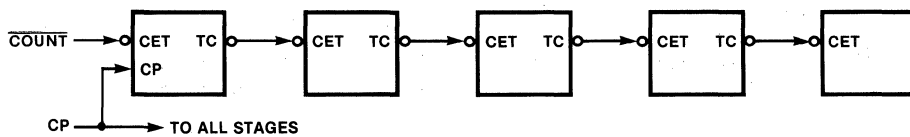
INPUTS				OUTPUT
$\overline{CEP}$	$\overline{CET}$	$\overline{TC}^*$	CP	$\overline{CC}$
H	X	X	X	H
X	H	X	X	H
X	X	H	X	H
L	L	L		

\* =  $\overline{TC}$  is generated internally  
 H = HIGH Voltage Level  
 L = LOW Voltage Level  
 X = Immaterial

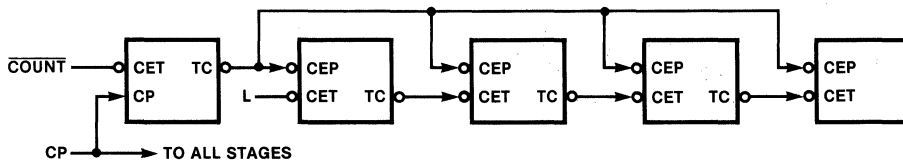
**Logic Equations:**

Count Enable =  $\overline{CEP} \cdot \overline{CET} \cdot PE$   
 Up ('F568):  $\overline{TC} = Q_0 \cdot \overline{Q_1} \cdot \overline{Q_2} \cdot Q_3 \cdot (Up) \cdot \overline{CET}$   
 ('F569):  $\overline{TC} = Q_0 \cdot Q_1 \cdot Q_2 \cdot Q_3 \cdot (Up) \cdot \overline{CET}$   
 Down (Both):  $\overline{TC} = \overline{Q_0} \cdot \overline{Q_1} \cdot \overline{Q_2} \cdot \overline{Q_3} \cdot (Down) \cdot \overline{CET}$

**Fig a Multistage Counter with Ripple Carry**



**Fig b Multistage Counter with Lookahead Carry**



**DC Characteristics over Operating Temperature Range** (unless otherwise specified)

Symbol	Parameter	54F/74F			Units	Conditions
		Min	Typ	Max		
I <sub>CC</sub>	Power Supply Current		40	60	mA	V <sub>CC</sub> = Max

**AC Characteristics:** See Section 3 for waveforms and load configurations

Symbol	Parameter	54F/74F			54F		74F		Units	Fig. No.
		T <sub>A</sub> = +25°C, V <sub>CC</sub> = +5.0 V C <sub>L</sub> = 50 pF			T <sub>A</sub> , V <sub>CC</sub> = Mil C <sub>L</sub> = 50 pF		T <sub>A</sub> , V <sub>CC</sub> = Com C <sub>L</sub> = 50 pF			
		Min	Typ	Max	Min	Max	Min	Max		
f <sub>max</sub>	Maximum Clock frequency	75							MHz	3-1, 3-7
t <sub>PLH</sub>	Propagation Delay	4.0	7.0	10					ns	3-1
t <sub>PHL</sub>	CP to O <sub>n</sub> (PE HIGH or LOW)	5.5	9.0	12.5					ns	3-7
t <sub>PLH</sub>	Propagation Delay	6.5	10.5	15					ns	3-1
t <sub>PHL</sub>	CP to $\overline{TC}$	6.5	10.5	15					ns	3-7
t <sub>PLH</sub>	Propagation Delay	4.0	6.5	9.0					ns	3-1
t <sub>PHL</sub>	$\overline{CET}$ to $\overline{TC}$	3.5	5.5	8.0					ns	3-4
t <sub>PLH</sub>	Propagation Delay	4.0	6.5	9.0					ns	3-1
t <sub>PHL</sub>	U/ $\overline{D}$ to $\overline{TC}$	4.5	7.5	10					ns	3-2
t <sub>PLH</sub>	Propagation Delay	3.5	6.0	8.5					ns	3-1
t <sub>PHL</sub>	CP to $\overline{CC}$	3.0	5.0	7.0					ns	3-4
t <sub>PLH</sub>	Propagation Delay	3.5	6.0	8.5					ns	3-1
t <sub>PHL</sub>	$\overline{CEP}$ , $\overline{CET}$ to $\overline{CC}$	4.5	8.0	12					ns	3-4
t <sub>PHL</sub>	Propagation Delay	6.0	10	14					ns	3-1 3-11
t <sub>PZH</sub>	Output Enable Time	6.0	10	14					ns	3-1
t <sub>PZL</sub>	$\overline{OE}$ to O <sub>n</sub>	7.0	12	17						3-12
t <sub>PHZ</sub>	Output Disable Time	3.5	6.0	8.5					ns	3-13
t <sub>PLZ</sub>	$\overline{OE}$ to O <sub>n</sub>	3.5	6.0	8.5						

■ Test limits in screened columns are preliminary.

AC Operating Requirements: See Section 3 for waveforms

Symbol	Parameter	54F/74F			54F		74F		Units	Fig. No.
		T <sub>A</sub> = +25°C, V <sub>CC</sub> = +5.0 V			T <sub>A</sub> , V <sub>CC</sub> = Mil		T <sub>A</sub> , V <sub>CC</sub> = Com			
		Min	Typ	Max	Min	Max	Min	Max		
t <sub>s</sub> (H) t <sub>s</sub> (L)	Setup Time, HIGH or LOW P <sub>n</sub> to CP	5.0						ns	3-5	
t <sub>h</sub> (H) t <sub>h</sub> (L)	Hold Time, HIGH or LOW P <sub>n</sub> to CP	3.0 3.0								
t <sub>s</sub> (H) t <sub>s</sub> (L)	Setup Time, HIGH or LOW CEP or CET to CP	10 10						ns	3-5	
t <sub>h</sub> (H) t <sub>h</sub> (L)	Hold Time, HIGH or LOW CEP or CET to CP	0 0								
t <sub>s</sub> (H) t <sub>s</sub> (L)	Setup Time, HIGH or LOW PE to CP	10 7.0						ns	3-5	
t <sub>h</sub> (H) t <sub>h</sub> (L)	Hold Time, HIGH or LOW PE to CP	0 0								
t <sub>s</sub> (H) t <sub>s</sub> (L)	Setup Time, HIGH or LOW U/D to CP	14 14						ns	3-5	
t <sub>h</sub> (H) t <sub>h</sub> (L)	Hold Time, HIGH or LOW U/D to CP	0 0								
t <sub>s</sub> (H) t <sub>s</sub> (L)	Setup Time, HIGH or LOW SR to CP	8.0 6.0						ns	3-5	
t <sub>h</sub> (H) t <sub>h</sub> (L)	Hold Time, HIGH or LOW SR to CP	3.0 3.0								
t <sub>w</sub> (H) t <sub>w</sub> (L)	CP Pulse Width, HIGH or LOW	4.5 6.5						ns	3-7	
t <sub>w</sub> (L)	MR Pulse Width LOW	5.0						ns	3-11	
t <sub>rec</sub>	MR Recovery Time	7.0						ns	3-11	
t <sub>rec</sub>	SR Recovery Time	8.0						ns	3-11	

■ Test limits in screened columns are preliminary.

# 54F/74F588

## Octal Bidirectional Transceiver

(With 3-State Inputs/Outputs and IEEE-488 Termination Resistors)

### Description

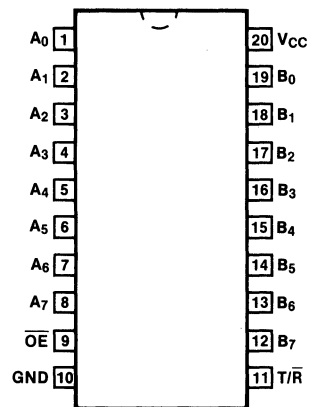
The 'F588 contains eight non-inverting bidirectional buffers with 3-state outputs and is intended for bus-oriented applications. The B ports have termination resistors as specified in the IEEE-488 specifications. Current sinking capability is 20 mA at the A ports and 48 mA at the B ports. The Transmit/Receive (T/R) input determines the direction of data flow through the bidirectional transceiver. Transmit (active-HIGH) enables data from A ports to B ports; Receive (active-LOW) enables data from B ports to A ports. The Output Enable input, when HIGH, disables both A and B ports by placing them in a high-impedance condition.

- Non-inverting Buffers
- Bidirectional Data Path
- B Outputs Sink 48 mA, Source 15 mA

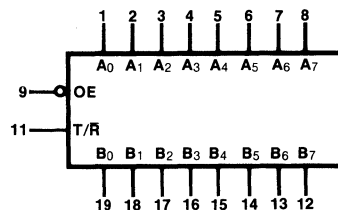
Ordering Code: See Section 6

Pkgs	Commercial Grade	Military Grade	Pkg Type
	$V_{CC} = +5.0\text{ V} \pm 5\%$ , $T_A = 0^\circ\text{ C to } +70^\circ\text{ C}$	$V_{CC} = +5.0\text{ V} \pm 10\%$ , $T_A = -55^\circ\text{ C to } +125^\circ\text{ C}$	
Plastic DIP (P)	74F588PC		9Z
Ceramic DIP (D)	74F588DC	54F588DM	4E
Flatpak (F)		54F588FM	4D

### Connection Diagram



### Logic Symbol



$V_{CC} = \text{Pin } 20$   
 $GND = \text{Pin } 10$

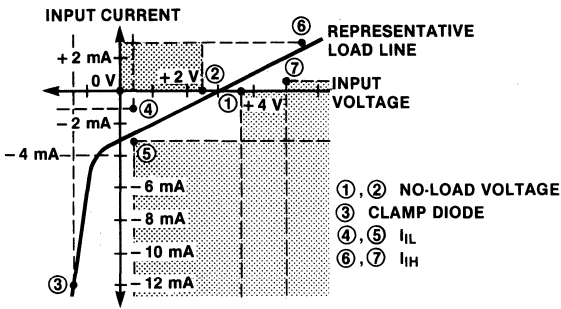
4

Input Loading/Fan-Out: See Section 3 for U.L. definitions

Pin Names	Description	54F/74F (U.L.) HIGH/LOW
$\overline{OE}$	Output Enable Input (Active LOW)	1.0/0.94
T/R	Transmit/Receive Control Input	0.5/0.47
A <sub>0</sub> - A <sub>7</sub>	A Port Inputs or 3-State Outputs	1.75/0.41 75/12.5
B <sub>0</sub> - B <sub>7</sub>	B Port Inputs or 3-State Outputs	T*/2.0 130/30

\*T = Restive Termination per IEEE-488 Standard

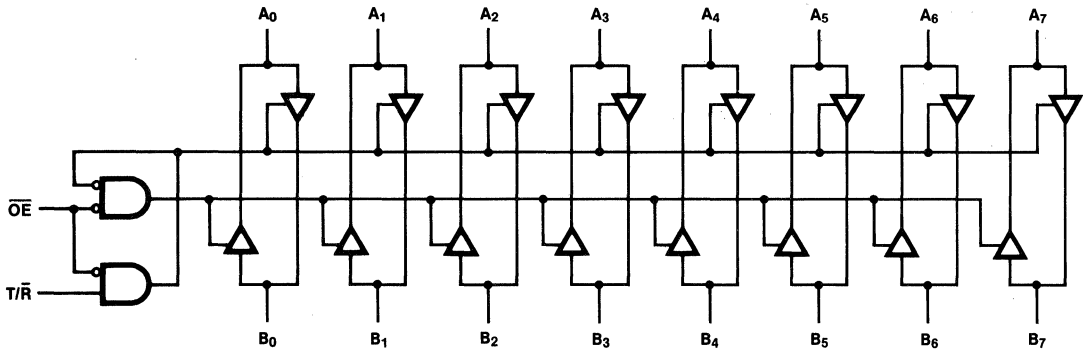
**B Port Input Characteristic with T/R LOW**



**Truth Table**

INPUTS		OUTPUTS
$\overline{OE}$	T/R	
L	L	Bus B Data to Bus A
L	H	Bus A Data to Bus B
H	X	High Impedance

**Logic Diagram**



## DC Characteristics over Operating Temperature Range (unless otherwise specified)

Symbol	Parameter		54F/74F			Units	Conditions
			Min	Typ	Max		
$V_{OH}$	Output HIGH Voltage A <sub>0</sub> -A <sub>7</sub> , B <sub>0</sub> -B <sub>7</sub>		2.4			V	$I_{OH} = -3.0$ mA, $V_{CC} = \text{Min}$ $V_{IN} = V_{IH}$ , $\overline{OE} = \text{LOW}$ , $T/\overline{R} = \text{HIGH}$
$V_{OL}$	Output LOW Voltage B <sub>0</sub> -B <sub>7</sub>	XM	0.55			V	$I_{OL} = 48$ mA, $\overline{OE} = \text{LOW}$ , $I_{OL} = 64$ mA, $T/\overline{R} = \text{HIGH}$
		XC					
$V_{NL}$	No-load Voltage B <sub>0</sub> -B <sub>7</sub>		2.5	3.7		V	$T/\overline{R} = \text{LOW}$ , $I_{OUT} = 0$
$V_{T+} - V_{T-}$	Hysteresis Voltage B <sub>0</sub> -B <sub>7</sub>		0.2			V	$T/\overline{R}$ , $\overline{OE} = \text{LOW}$ , $V_{CC} = \text{Min}$
$I_{IH}$	Input HIGH Current Breakdown Test, A <sub>0</sub> -A <sub>7</sub>		100			$\mu\text{A}$	$V_{IN} = 5.5$ V
$I_{IH}$	Input HIGH Current B <sub>0</sub> -B <sub>7</sub>		0.7	2.5		mA	$V_{IN} = 5.0$ V, $T/\overline{R} = \text{LOW}$
$I_{IL}$	Input LOW Current B <sub>0</sub> -B <sub>7</sub>		1.3	3.2		mA	$V_{IN} = 0.4$ V, $T/\overline{R} = \text{LOW}$
$I_{IH} + I_{OZH}$	3-State Output OFF Current HIGH, A <sub>0</sub> -A <sub>7</sub>		70			$\mu\text{A}$	$V_{IN} = 2.7$ V, $T/\overline{R} = \text{HIGH}$ $V_{CC} = \text{Max}$
$I_{CC}$	Power Supply Current		128	192		mA	$\overline{OE} = \text{HIGH}$ , $V_{CC} = \text{Max}$

4

## AC Characteristics: See Section 3 for waveforms and load configurations

Symbol	Parameter	54F/74F			54F		74F		Units	Fig. No.
		$T_A = +25^\circ\text{C}$ , $V_{CC} = +5.0$ V $C_L = 50$ pF			$T_A, V_{CC} =$ Mil $C_L = 50$ pF		$T_A, V_{CC} =$ Com $C_L = 50$ pF			
		Min	Typ	Max	Min	Max	Min	Max		
$t_{PLH}$	Propagation Delay A to B or B to A	3.5	6.5	9.1				ns	3-1	
$t_{PHL}$		3.5	6.5	9.1					3-4	
$t_{PZH}$	Output Enable Time $T/\overline{R}$ or $\overline{OE}$ to A or B	4.0	7.0	10				ns	3-1	
$t_{PZL}$		5.5	8.5	14					3-12	
$t_{PHZ}$	Output Disable Time $T/\overline{R}$ or $\overline{OE}$ to A or B	5.5	8.5	14					3-13	
$t_{PLZ}$		4.0	7.0	10						

■ Test limits in screened columns are preliminary.

# 54F/74F673

## 16-Bit Shift Register

(Serial-in/Serial-Parallel Out)

### Description

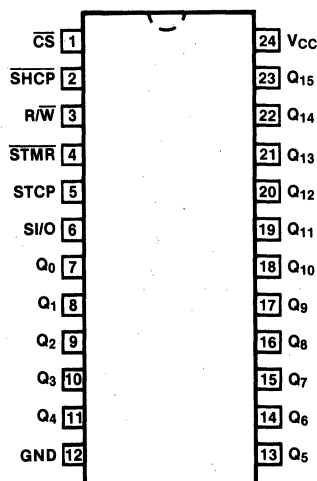
The 'F673 contains a 16-bit serial-in/serial-out shift register and a 16-bit parallel-out storage register. A single pin serves either as an input for serial entry or as a 3-state serial output. In the Serial-out mode, the data recirculates in the shift register. By means of a separate clock, the contents of the shift register are transferred to the storage register for parallel outputting. The contents of the storage register can also be parallel loaded back into the shift register. A HIGH signal on the Chip Select input prevents both shifting and parallel transfer. The storage register may be cleared via STMR.

- Serial-to-Parallel Converter
- 16-Bit Serial I/O Shift Register
- 16-Bit Parallel-out Storage Register
- Recirculating Serial Shifting
- Recirculating Parallel Transfer
- Common Serial Data I/O Pin

Ordering Code: See Section 6

Pkgs	Commercial Grade	Military Grade	Pkg Type
	V <sub>CC</sub> = +5.0 V ±5%, T <sub>A</sub> = 0° C to +70° C	V <sub>CC</sub> = +5.0 V ±10%, T <sub>A</sub> = -55° C to +125° C	
Plastic DIP (P)	74F673PC		9N
Ceramic DIP (D)	74F673DC	54F673DM	6N
Flatpak (F)		54F673FM	4M

### Connection Diagram



Input Loading/Fan-Out: See Section 3 for U.L. definitions

Pin Names	Description	54F/74F (U.L.) HIGH/LOW
CS	Chip Select Input (Active LOW)	0.5/0.375
SHCP	Shift Clock Pulse Input (Active Falling Edge)	0.5/0.375
STMR	Store Master Reset Input (Active LOW)	0.5/0.375
STCP	Store Clock Pulse Input	0.5/0.375
R/W	Read/Write Input	0.5/0.375
SI/O	Serial Data Input or 3-State Serial Output	1.75/0.375
Q <sub>0</sub> - Q <sub>15</sub>	Parallel Data Outputs	25/12.5

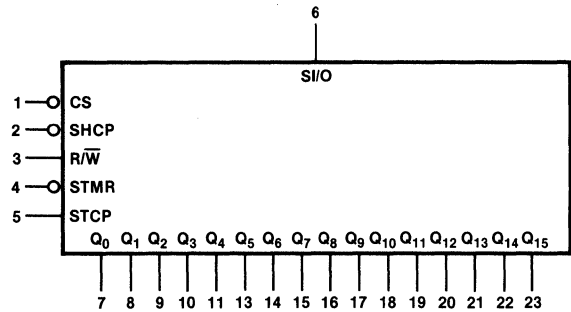
**Functional Description**

The 16-bit shift register operates in one of four modes, as indicated in the Shift Register Operations Table. A HIGH signal on the Chip Select ( $\overline{CS}$ ) input prevents clocking and forces the Serial Input/Output (SI/O) 3-state buffer into the high-impedance state. During serial shift-out operations, the SI/O buffer is active (i.e., enabled) and the output data is also recirculated back into the shift register. When parallel loading the shift register from the storage register, serial shifting is inhibited.

The storage register has an asynchronous master reset ( $\overline{STMR}$ ) input that overrides all other inputs and forces the  $Q_0 - Q_{15}$  outputs LOW. The storage register is in the Hold mode when either  $\overline{CS}$  or the Read/Write ( $R/\overline{W}$ ) input is HIGH. With  $\overline{CS}$  and  $R/\overline{W}$  both LOW, the storage register is parallel loaded from the shift register.

To prevent false clocking of the shift register,  $\overline{SHCP}$  should be in the LOW state during a LOW-to-HIGH transition of  $\overline{CS}$ . To prevent false clocking of the storage register,  $\overline{STMR}$  should be LOW during a HIGH-to-LOW transition of  $\overline{CS}$  if  $R/\overline{W}$  is LOW, and should also be LOW during a HIGH-to-LOW transition of  $R/\overline{W}$  if  $\overline{CS}$  is LOW.

**Logic Symbol**



VCC = Pin 24  
GND = Pin 12

4

**Storage Register Operations Table**

CONTROL INPUTS				OPERATING MODE
$\overline{STMR}$	$\overline{CS}$	$R/\overline{W}$	$\overline{STCP}$	
L	X	X	X	Reset; Outputs LOW
H	H	X	X	Hold
H	X	H	X	Hold
H	L	L	$\overline{\text{L}}$	Parallel Load

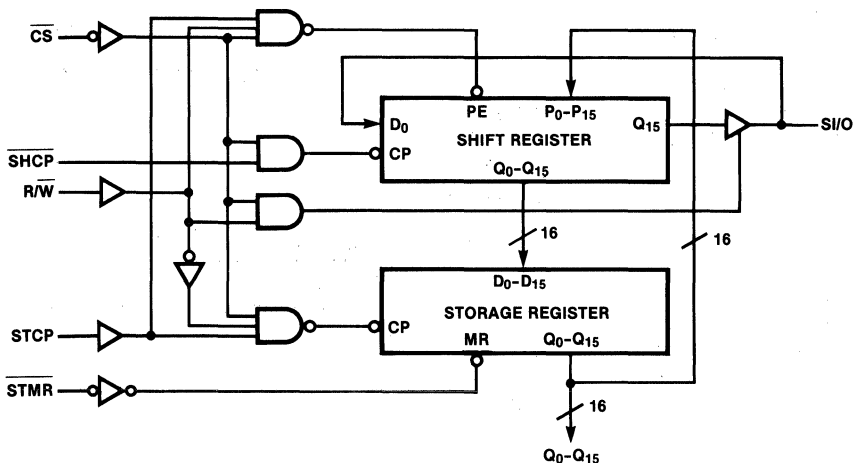
**Shift Register Operations Table**

CONTROL INPUTS				SI/O STATUS	OPERATING MODE
$\overline{CS}$	$R/\overline{W}$	$\overline{SHCP}$	$\overline{STCP}$		
H	X	X	X	High Z	Hold
L	L	X	X	Data In	Serial Load
L	H	$\overline{\text{L}}$	L	Data Out	Serial Output with Recirculation
L	H	$\overline{\text{L}}$	H	Active	Parallel Load; No Shifting

H = HIGH Voltage Level  
L = LOW Voltage Level  
X = Immaterial



## Functional Block Diagram



Please note that this diagram is provided only for the understanding of logic operations and should not be used to estimate propagation delays

## DC Characteristics over Operating Temperature Range (unless otherwise specified)

Symbol	Parameter	54F/74F			Units	Conditions
		Min	Typ	Max		
$I_{IH} + I_{OZH}$	3-State Output OFF Current HIGH, S/O			70	$\mu A$	$V_{IN} = 2.7 V, V_{CC} = Max$
$I_{IL} + I_{OZL}$	3-State Output OFF Current LOW, S/O			650	$\mu A$	$V_{IN} = 0.5 V, V_{CC} = Max$
$I_{CC}$	Power Supply Current		106	160	mA	$V_{CC} = Max$

**AC Characteristics:** See Section 3 for waveforms and load configurations

Symbol	Parameter	54F/74F			54F		74F		Units	Fig. No.
		T <sub>A</sub> = +25°C, V <sub>CC</sub> = +5.0 V C <sub>L</sub> = 50 pF			T <sub>A</sub> , V <sub>CC</sub> = Mil C <sub>L</sub> = 50 pF		T <sub>A</sub> , V <sub>CC</sub> = Com C <sub>L</sub> = 50 pF			
		Min	Typ	Max	Min	Max	Min	Max		
f <sub>max</sub>	Maximum Clock Frequency	100	140					MHz	3-1, 3-8	
t <sub>PLH</sub>	Propagation Delay	7.5	13	18				ns	3-1 3-7	
t <sub>PHL</sub>	STCP to Q <sub>n</sub>	9.5	16	22						
t <sub>PHL</sub>	Propagation Delay	6.0	10	14				ns	3-1 3-11	
t <sub>PLH</sub>	Propagation Delay	4.5	8.0	11						
t <sub>PHL</sub>	SHCP to SI/O	5.0	9.0	12.5				ns	3-1 3-8	
t <sub>PZH</sub>	Output Enable Time	3.0	5.0	7.0						
t <sub>PZL</sub>	CS or R/W to SI/O	3.0	5.0	7.0				ns	3-1 3-12 3-13	
t <sub>PHZ</sub>	Output Disable Time	3.0	5.0	7.0						
t <sub>PLZ</sub>	CS or R/W to SI/O	3.0	5.0	7.0						

**AC Operating Requirements:** See Section 3 for waveforms

Symbol	Parameter	54F/74F			54F		74F		Units	Fig. No.
		T <sub>A</sub> = +25°C, V <sub>CC</sub> = +5.0 V			T <sub>A</sub> , V <sub>CC</sub> = Mil		T <sub>A</sub> , V <sub>CC</sub> = Com			
		Min	Typ	Max	Min	Max	Min	Max		
t <sub>s</sub> (H)	Setup Time, HIGH or LOW	7.0						ns	3-5	
t <sub>s</sub> (L)	CS or R/W to STCP	7.0								
t <sub>h</sub> (H)	Hold Time, HIGH or LOW	0						ns	3-6	
t <sub>h</sub> (L)	CS or R/W to STCP	0								
t <sub>s</sub> (H)	Setup Time, HIGH or LOW	3.0						ns	3-6	
t <sub>s</sub> (L)	SI/O to SHCP	3.0								
t <sub>h</sub> (H)	Hold Time, HIGH or LOW	0						ns	3-6	
t <sub>h</sub> (L)	SI/O to SHCP	0								
t <sub>s</sub> (H)	Setup Time, HIGH or LOW	5.0						ns	3-6	
t <sub>s</sub> (L)	CS or R/W to SHCP	5.0								
t <sub>h</sub> (H)	Hold Time, HIGH or LOW	0						ns	3-8	
t <sub>h</sub> (L)	CS or R/W to SHCP	0								
t <sub>w</sub> (H)	SHCP Pulse Width,	4.0						ns	3-7	
t <sub>w</sub> (L)	HIGH or LOW	5.0								
t <sub>w</sub> (H)	STCP Pulse Width,	5.0						ns	3-7	
t <sub>w</sub> (L)	HIGH or LOW	10								
t <sub>w</sub> (L)	STMR Pulse Width LOW	7.0						ns	3-11	
t <sub>rec</sub>	Recovery Time	10						ns	3-11	
	STMR to STCP									

■ Test limits in screened columns are preliminary.

# 54F/74F674

## 16-Bit Shift Register

(Serial-Parallel-in/Serial-out)

### Description

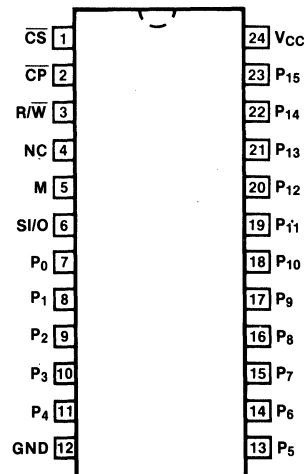
The 'F674 is a 16-bit shift register with serial and parallel load capability and serial output. A single pin serves alternately as an input for serial entry or as a 3-state serial output. In the Serial-out mode the data recirculates in the register. Chip Select, Read/Write and Mode inputs provide control flexibility.

- 16-Bit Serial I/O Shift Register
- 16-Bit Parallel-in/Serial-out Converter
- Recirculating Serial Shifting
- Common Serial Data I/O Pin

**Ordering Code:** See Section 6

Pkgs	Commercial Grade	Military Grade	Pkg Type
	$V_{CC} = +5.0\text{ V} \pm 5\%$ , $T_A = 0^\circ\text{C to } +70^\circ\text{C}$	$V_{CC} = +5.0\text{ V} \pm 10\%$ , $T_A = -55^\circ\text{C to } +125^\circ\text{C}$	
Plastic DIP (P)	74F674PC		9N
Ceramic DIP (D)	74F674DC	54F674DM	6N
Flatpak (F)		54F674FM	4M

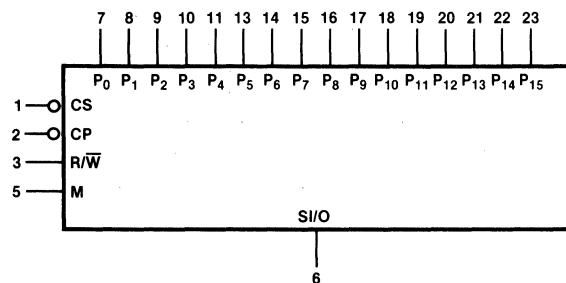
### Connection Diagram



**Input Loading/Fan-Out:** See Section 3 for U.L. definitions

Pin Names	Description	54F/74F (U.L.) HIGH/LOW
$P_0 - P_{15}$	Parallel Data Inputs	0.5/0.375
$\overline{CS}$	Chip Select Input (Active LOW)	0.5/0.375
$\overline{CP}$	Clock Pulse Input (Active LOW)	0.5/0.375
M	Mode Select Input	0.5/0.375
$R/\overline{W}$	Read/Write Input	0.5/0.375
S/I/O	3-State Serial Data Input or 3-State Serial Output	1.75/0.375 25/12.5

### Logic Symbol



$V_{CC} = \text{Pin } 24$   
 $GND = \text{Pin } 12$

### Functional Description

The 16-bit shift register operates in one of four modes, as indicated in the Shift Register Operations Table.

**Hold** — a HIGH signal on the Chip Select ( $\overline{CS}$ ) input prevents clocking and forces the Serial Input/Output (SI/O) 3-state buffer into the high-impedance state.

**Serial Load** — data present on the SI/O pin shifts into the register on the falling edge of  $\overline{CP}$ . Data enters the  $Q_0$  position and shifts toward  $Q_{15}$  on successive clocks.

**Serial Output** — the SI/O 3-state buffer is active and the register contents are shifted out from  $Q_{15}$  and simultaneously shifted back into  $Q_0$ .

**Parallel Load** — data present on  $P_0$ – $P_{15}$  are entered into the register on the falling edge of  $\overline{CP}$ . The SI/O 3-state buffer is active and represents the  $Q_{15}$  output.

To prevent false clocking,  $\overline{CP}$  must be LOW during a LOW-to-HIGH transition of  $\overline{CS}$ .

Shift Register Operations Table

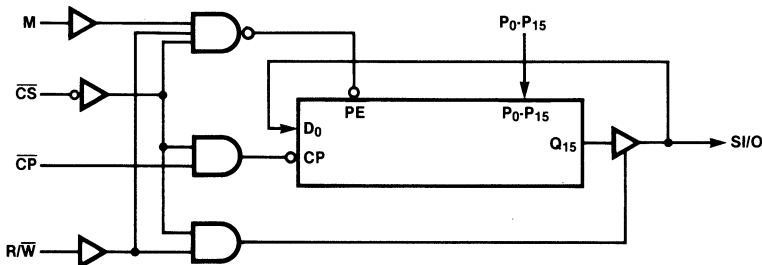
CONTROL INPUTS				SI/O STATUS	OPERATING MODE
$\overline{CS}$	R/W	M	$\overline{CP}$		
H	X	X	X	High Z	Hold
L	L	X	$\downarrow$	Data In	Serial Load
L	H	L	$\downarrow$	Data Out	Serial Output with Recirculation
L	H	H	$\downarrow$	Active	Parallel Load; No Shifting

H = HIGH Voltage Level

L = LOW Voltage Level

X = Immaterial

### Functional Block Diagram



**DC Characteristics over Operating Temperature Range** (unless otherwise specified)

Symbol	Parameter	54F/74F			Units	Conditions
		Min	Typ	Max		
$I_{IH} + I_{OZH}$	3-State Output OFF Current HIGH, SI/O			70	$\mu A$	$V_{IN} = 2.7 V, V_{CC} = \text{Max}$
$I_{IL} + I_{OLZ}$	3-State Output OFF Current LOW, SI/O			650	$\mu A$	$V_{IN} = 0.5 V, V_{CC} = \text{Max}$
$I_{CC}$	Power Supply Current		53	80	mA	$V_{CC} = \text{Max}$

**AC Characteristics:** See Section 3 for waveforms and load configurations

Symbol	Parameter	54F/74F			54F		74F		Units	Fig. No.
		$T_A = +25^\circ C, V_{CC} = +5.0 V, C_L = 50 pF$			$T_A, V_{CC} = \text{Mil}, C_L = 50 pF$		$T_A, V_{CC} = \text{Com}, C_L = 50 pF$			
		Min	Typ	Max	Min	Max	Min	Max		
$f_{max}$	Maximum Clock Frequency	100	140					MHz	3-1, 3-8	
$t_{PLH}$ $t_{PHL}$	Propagation Delay CP to SI/O	4.5 5.0	8.0 9.0	11 12.5				ns	3-1 3-8	
$t_{PZH}$ $t_{PZL}$	Output Enable Time CS or R/W to SI/O	3.0 3.0	5.0 5.0	7.0 7.0				ns	3-1 3-12 3-13	
$t_{PHZ}$ $t_{PLZ}$	Output Disable Time CS or R/W to SI/O	3.0 3.0	5.0 5.0	7.0 7.0						

**AC Operating Requirements:** See Section 3 for waveforms

Symbol	Parameter	54F/74F			54F		74F		Units	Fig. No.
		$T_A = +25^\circ C, V_{CC} = +5.0 V$			$T_A, V_{CC} = \text{Mil}$		$T_A, V_{CC} = \text{Com}$			
		Min	Typ	Max	Min	Max	Min	Max		
$t_s (H)$ $t_s (L)$	Setup Time, HIGH or LOW SI/O to CP	7.0 7.0						ns	3-6	
$t_h (H)$ $t_h (L)$	Hold Time, HIGH or LOW SI/O to CP	0 0								
$t_s (H)$ $t_s (L)$	Setup Time, HIGH or LOW $P_n$ to $\overline{CP}$	3.0 3.0						ns	3-6	
$t_h (H)$ $t_h (L)$	Hold Time, HIGH or LOW $P_n$ to $\overline{CP}$	0 0								
$t_s (H)$ $t_s (L)$	Setup Time, HIGH or LOW R/W or CS to CP	5.0 5.0						ns	3-6	
$t_h (H)$ $t_h (L)$	Hold Time, HIGH or LOW R/W or CS to CP	0 0								
$t_w (H)$ $t_w (L)$	CP Pulse Width, HIGH or LOW	4.0 5.0						ns	3-8	

■ Test limits in screened columns are preliminary.

**54F/74F675****16-Bit Shift Register**

(Serial-in/Serial-Parallel Out)

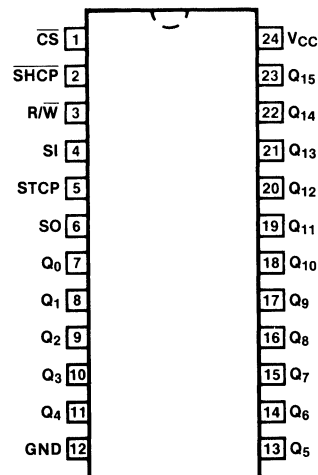
**Description**

The 'F675 contains a 16-bit serial-in/serial-out shift register and a 16-bit parallel-out storage register. Separate serial input and output pins are provided for expansion to longer words. By means of a separate clock, the contents of the shift register are transferred to the storage register. The contents of the storage register can also be loaded back into the shift register. A HIGH signal on the Chip Select input prevents both shifting and parallel loading.

- Serial-to-Parallel Converter
- 16-Bit Serial I/O Shift Register
- 16-Bit Parallel-out Storage Register
- Recirculating Parallel Transfer
- Expandable for Longer Words

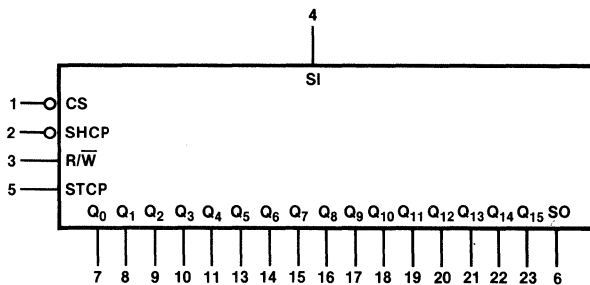
**Ordering Code:** See Section 6

Pkgs	Commercial Grade	Military Grade	Pkg Type
	$V_{CC} = +5.0\text{ V} \pm 5\%$ , $T_A = 0^\circ\text{C to } +70^\circ\text{C}$	$V_{CC} = +5.0\text{ V} \pm 10\%$ , $T_A = -55^\circ\text{C to } +125^\circ\text{C}$	
Plastic DIP (P)	74F675PC		9N
Ceramic DIP (D)	74F675DC	54F675DM	6N
Flatpak (F)		54F675FM	4M

**Connection Diagram****Input Loading/Fan-Out:** See Section 3 for U.L. definitions

Pin Names	Description	54F/74F (U.L.) HIGH/LOW
SI	Serial Data Input	0.5/0.375
CS	Chip Select Input (Active LOW)	0.5/0.375
SHCP	Shift Clock Pulse Input (Active Falling Edge)	0.5/0.375
STCP	Store Clock Pulse Input (Active Rising Edge)	0.5/0.375
R/W	Read/Write Input	0.5/0.375
SO	Serial Data Output	25/12.5
Q0 - Q15	Parallel Data Outputs	25/12.5

## Logic Symbol



V<sub>CC</sub> = Pin 24  
GND = Pin 12

## Functional Description

The 16-bit shift register operates in one of four modes, as determined by the signals applied to the Chip Select ( $\overline{CS}$ , Read/Write (R/W) and Store Clock Pulse (STCP) input. State changes are indicated by the falling edge of the Shift Clock Pulse ( $\overline{SHCP}$ ). In the Shift-right mode, data enters D<sub>0</sub> from the Serial Input (SI) pin and exits from Q<sub>15</sub> via the Serial Data Output (SO) pin. In the Parallel Load mode, data from the storage register outputs enter the shift register and serial shifting is inhibited.

The storage register is in the Hold mode when either  $\overline{CS}$  or R/W is HIGH. With  $\overline{CS}$  and R/W both LOW, the storage register is parallel loaded from the shift register on the rising edge of STCP.

To prevent false clocking of the shift register,  $\overline{SHCP}$  should be in the LOW state during a LOW-to-HIGH transition of  $\overline{CS}$ . To prevent false clocking of the storage register, STCP should be LOW during a HIGH-to-LOW transition of  $\overline{CS}$  if R/W is LOW, and should also be LOW during a HIGH-to-LOW transition of R/W if  $\overline{CS}$  is LOW.

## Shift Register Operations Table

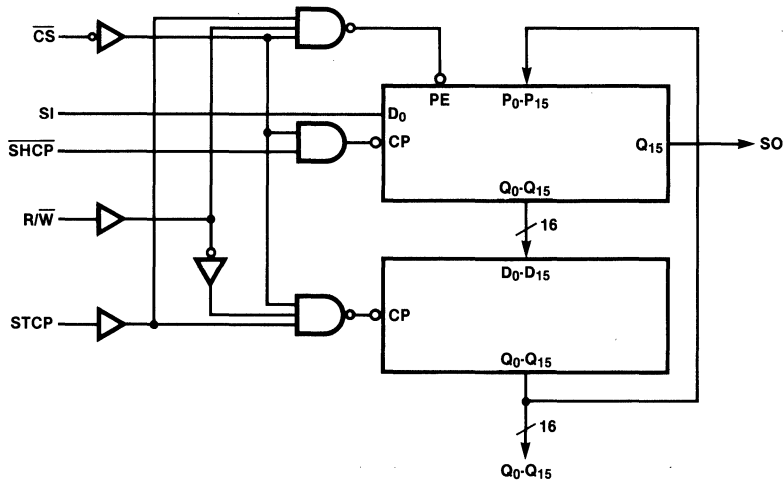
CONTROL INPUTS				OPERATING MODE
$\overline{CS}$	R/W	$\overline{SHCP}$	STCP	
H	X	X	X	Hold
L	L		X	Shift Right
L	H		L	Shift Right
L	H		H	Parallel Load; No Shifting

## Storage Register Operations Table

INPUTS			OPERATING MODE
$\overline{CS}$	R/W	STCP	
H	X	X	Hold
L	H	X	Hold
L	L		Parallel Load

H = HIGH Voltage Level  
L = LOW Voltage Level  
X = Immaterial

## Functional Block Diagram



Please note that this diagram is provided only for the understanding of logic operations and should not be used to estimate propagation delays.

## DC Characteristics over Operating Temperature Range (unless otherwise specified)

Symbol	Parameter	54F/74F			Units	Conditions
		Min	Typ	Max		
I <sub>CC</sub>	Power Supply Current		106	160	mA	V <sub>CC</sub> = Max



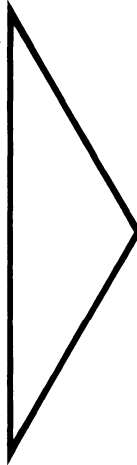
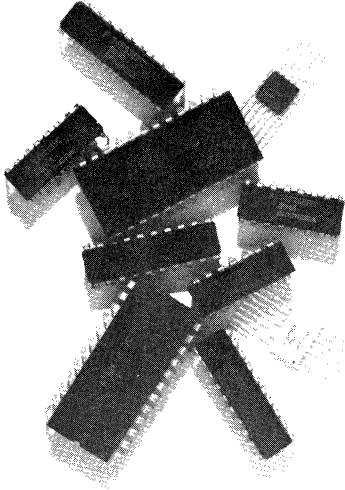
**AC Characteristics:** See Section 3 for waveforms and load configurations

Symbol	Parameter	54F/74F			54F		74F		Units	Fig. No.
		T <sub>A</sub> = +25°C, V <sub>CC</sub> = +5.0 V C <sub>L</sub> = 50 pF			T <sub>A</sub> , V <sub>CC</sub> = Mil C <sub>L</sub> = 50 pF		T <sub>A</sub> , V <sub>CC</sub> = Com C <sub>L</sub> = 50 pF			
		Min	Typ	Max	Min	Max	Min	Max		
f <sub>max</sub>	Maximum Clock Frequency	100	140					MHz	3-1, 3-8	
t <sub>PLH</sub>	Propagation Delay	7.5	13	18				ns	3-1 3-7	
t <sub>PHL</sub>	STCP to Q <sub>n</sub>	9.5	16	22						
t <sub>PLH</sub>	Propagation Delay	4.5	8.0	11				ns	3-1 3-8	
t <sub>PHL</sub>	SHCP to SO	5.0	9.0	12.5						

**AC Operating Requirements:** See Section 3 for waveforms

Symbol	Parameter	54F/74F			54F		74F		Units	Fig. No.
		T <sub>A</sub> = +25°C, V <sub>CC</sub> = +5.0 V			T <sub>A</sub> , V <sub>CC</sub> = Mil		T <sub>A</sub> , V <sub>CC</sub> = Com			
		Min	Typ	Max	Min	Max	Min	Max		
t <sub>s</sub> (H)	Setup Time, HIGH or LOW	7.0						ns	3-5	
t <sub>s</sub> (L)	$\overline{\text{CS}}$ or R/ $\overline{\text{W}}$ to STCP	7.0								
t <sub>h</sub> (H)	Hold Time, HIGH or LOW	0						ns	3-6	
t <sub>h</sub> (L)	$\overline{\text{CS}}$ or R/ $\overline{\text{W}}$ to STCP	0								
t <sub>s</sub> (H)	Setup Time, HIGH or LOW	3.0						ns	3-6	
t <sub>s</sub> (L)	SI to SHCP	3.0								
t <sub>h</sub> (H)	Hold Time, HIGH or LOW	0						ns	3-6	
t <sub>h</sub> (L)	SI to SHCP	0								
t <sub>s</sub> (H)	Setup Time, HIGH or LOW	5.0						ns	3-6	
t <sub>s</sub> (L)	R/ $\overline{\text{W}}$ or $\overline{\text{CS}}$ to SHCP	5.0								
t <sub>h</sub> (H)	Hold Time, HIGH or LOW	0						ns	3-8	
t <sub>h</sub> (L)	R/ $\overline{\text{W}}$ or $\overline{\text{CS}}$ to SHCP	0								
t <sub>w</sub> (H)	SHCP Pulse Width,	4.0						ns	3-8	
t <sub>w</sub> (L)	HIGH or LOW	5.0								
t <sub>w</sub> (H)	STCP Pulse Width,	5.0						ns	3-7	
t <sub>w</sub> (L)	HIGH or LOW	10								

■ Test limits in screened columns are preliminary.



<b>Product Index and Selection Guide</b>	<b>1</b>
<b>Circuit Characteristics</b>	<b>2</b>
<b>Ratings, Specifications and Waveforms</b>	<b>3</b>
<b>Data Sheets</b>	<b>4</b>
<b>New Products</b>	<b>5</b>
<b>Ordering Information and Package Outlines</b>	<b>6</b>
<b>Sales Offices, Representatives and Distributor Locations</b>	<b>7</b>



# 29F01

## 4-Bit Bipolar Microprocessor Slice

### Description

The 29F01 4-bit high-speed bipolar microprocessor slice is available in two speed versions, the 29F01-1 and 29F01-2. It features a 16-word by 4-bit dual-port Random Access Memory (RAM), a high-speed 8-function Arithmetic Logic Unit (ALU) and associated shifting, decoding and multiplexing circuitry. The microinstruction word consists of three groups of three bits that respectively control ALU operand source, ALU function and ALU result destination. Width of the data path may be increased by cascading with either ripple or full lookahead carry. Data outputs are 3-state for maximum versatility. Four status flag signals, carry, overflow, zero and sign, are

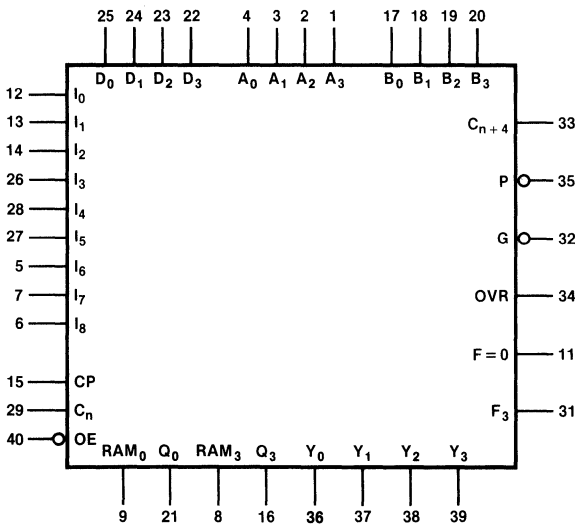
provided by the ALU. The microprocessor slice is compatible with Fairchild Advanced Schottky TTL (FAST) devices and can be used with FAST parts in microprogrammed systems to minimize cycle times.

The 29F01-1 and 29F01-2 are plug-in replacements for the 2901 series microprocessors.

**Isoplanar FAST Technology**  
**Plug-in Replacement for Standard 2901**  
**20% to 30% Faster than Standard 2901 in Most System Configurations**  
**Clock Pulse LOW Time 20 ns**

5

### Logic Symbol



V<sub>CC</sub> = Pin 10  
GND = Pin 30

# 29F10

## Microprogram Controller

### Description

The 29F10 is a high-speed bipolar microprogram controller. It is intended for use in controlling the execution sequence of microinstructions stored in microprogram memory. The 29F10 provides a 12-bit address during each clock cycle. This address comes from one of four sources: direct input from D<sub>0</sub>-D<sub>11</sub>, the Register/Counter, the Microprogram Counter-Register, or the 5-deep LIFO Stack. Address outputs are 3-state for maximum versatility.

The microprogram controller is compatible with Fairchild Advanced Schottky TTL (FAST) devices and can be used with FAST parts in microprogrammed systems to minimize cycle times.

**Addresses up to 4096 Words of Microcode  
Directly Loadable Down-counter for Counting  
Loop Iterations**

**Provides Count Capacity of 4096**

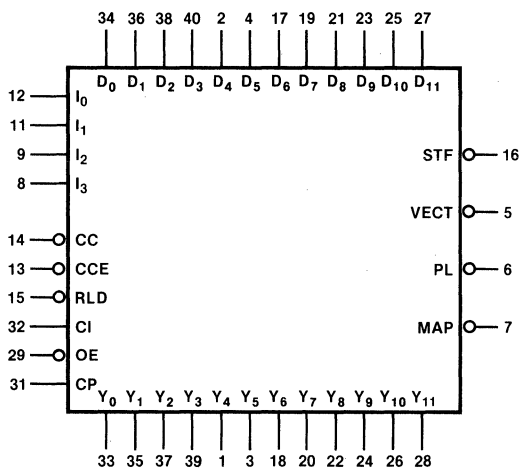
**Up-counter Provides Sequential Microinstruction  
Execution**

**5-Deep Push/Pop LIFO Stack Provides Subroutine  
Linkage and Branch Capabilities**

**All Registers Positive Edge-triggered**

**Plug-in Replacement for Standard 2910**

### Logic Symbol



V<sub>CC</sub> = Pin 10  
GND = Pin 30

# 29F705

16-Word by 4-Bit  
2-Port Random Access Memory

## Description

The 29F705 is a 16-word by 4-bit Random Access Memory (RAM). It provides two separate output ports to allow simultaneous reading of any two 4-bit words, and has 3-state outputs for bussing.

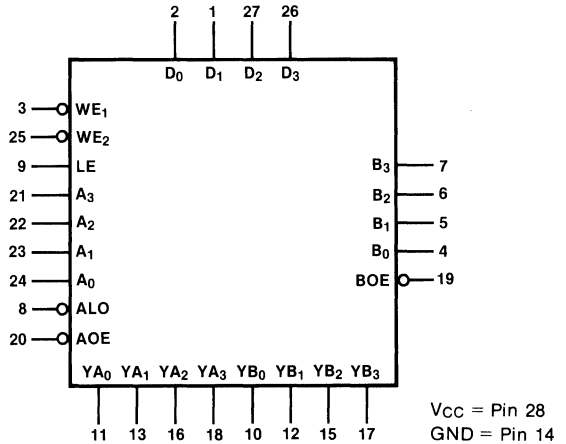
### High-speed Version of 29705

**16-Word by 4-Bit, 2-Port RAM**

**Separate 4-Bit Latches on Each Output Port**

**3-State Outputs**

## Logic Symbol



5

# 54F/74F211

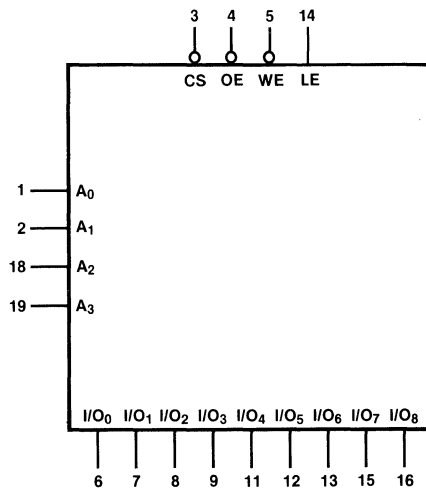
144-Bit Random Access Memory  
(With 3-State Outputs)

## Description

The 'F211 is a high-speed 144-bit Random Access Memory (RAM) organized as a 16-word by 9-bit array. It contains output latches that are transparent when the Latch Enable (LE) is HIGH. Inputs are buffered to minimize loading and are fully decoded on chip. The output buffers are active only in the Read mode when Chip Select ( $\overline{CS}$ ) and Output Enable ( $\overline{OE}$ ) are LOW, and Write Enable ( $\overline{WE}$ ) is HIGH; otherwise, the outputs are in the high-impedance state.

- 3-State Outputs for Bus Applications**
- Buffered Inputs for Minimum Loading**
- Address Decoding on Chip**
- Address Access Time 15 ns Typ**
- Chip Select Access Time 8 ns Typ**
- Supply Current 80 mA Typ**

## Logic Symbol



Vcc = Pin 20  
GND = Pin 10

# 54F/74F212

## 144-Bit Random Access Memory

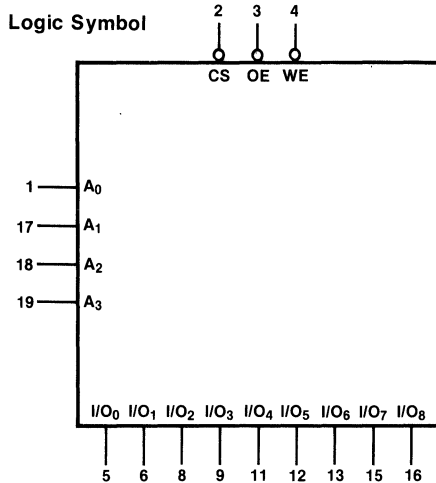
(With 3-State Outputs)

### Description

The 'F212 is a high-speed 144-bit Random Access Memory (RAM) organized as a 16-word by 9-bit array. Address inputs are buffered to minimize loading and are fully decoded on chip. The output buffers are active only in the Read mode when Chip Select ( $\overline{CS}$ ) and Output Enable ( $\overline{OE}$ ) are LOW, and Write Enable ( $\overline{WE}$ ) is HIGH; otherwise, the outputs are in the high-impedance state.

- 3-State Outputs for Bus Applications**
- Buffered Inputs for Minimum Loading**
- Address Decoding on Chip**
- Address Access Time 15 ns Typ**
- Chip Select Access Time 8 ns Typ**
- Supply Current 80 mA Typ**

V<sub>CC</sub> = Pin 20  
GND = Pin 10



# 54F/74F213

## 192-Bit Random Access Memory

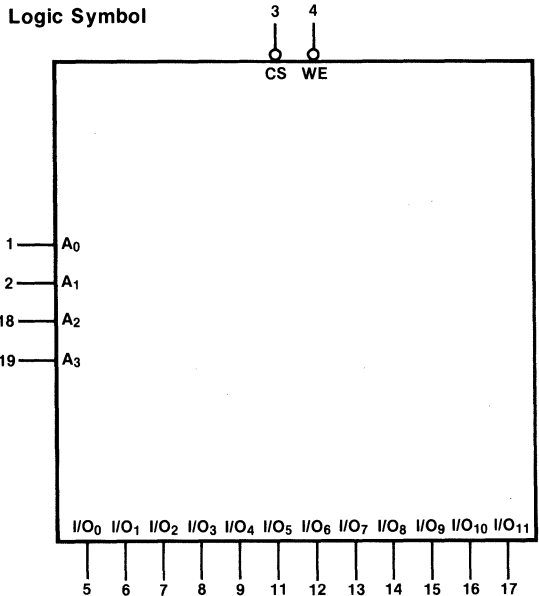
(With 3-State Outputs)

### Description

The 'F213 is a high-speed 192-bit Random Access Memory (RAM) organized as a 16-word by 12-bit array. Inputs are buffered to minimize loading and are fully decoded on chip. The output buffers are active only in the Read mode when Chip Select ( $\overline{CS}$ ) is LOW and Write Enable ( $\overline{WE}$ ) is HIGH; otherwise, the outputs are in the high-impedance state.

- 3-State Outputs for Bus Applications**
- Buffered Inputs for Minimum Loading**
- Address Decoding on Chip**
- Address Access Time 15 ns Typ**
- Chip Select Access Time 8 ns Typ**
- Supply Current 80 mA Typ**

V<sub>CC</sub> = Pin 20  
GND = Pin 10



# 54F/74F269

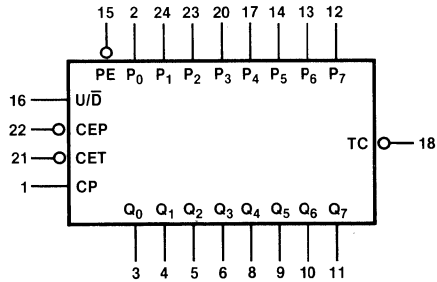
## 8-Bit Bidirectional Binary Counter

### Description

The 'F269 is a fully synchronous 8-stage up/down counter featuring a preset capability for programmable operation, carry lookahead for easy cascading and a  $U/\bar{D}$  input to control the direction of counting. All state changes, whether in counting or parallel loading, are initiated by the rising edge of the clock.

- Synchronous Counting and Loading**
- Built-in Lookahead Carry Capability**
- Count Frequency 100 MHz Typ**
- Supply Current 70 mA Typ**

### Logic Symbol



$V_{CC}$  = Pin 19  
GND = Pin 7

# 54F/74F311

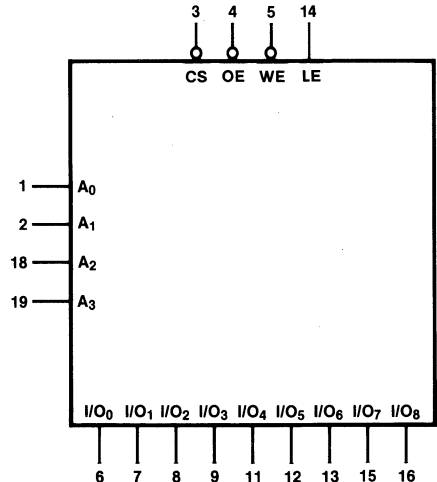
## 144-Bit Random Access Memory (With Open-collector Outputs)

### Description

The 'F311 is a high-speed 144-bit Random Access Memory (RAM) organized as a 16-word by 9-bit array. It contains output latches that are transparent when the Latch Enable (LE) is HIGH. Inputs are buffered to minimize loading and are fully decoded on chip. The output buffers are active only in the Read mode when Chip Select ( $\bar{CS}$ ) and Output Enable ( $\bar{OE}$ ) are LOW, and Write Enable ( $\bar{WE}$ ) is HIGH; otherwise, the outputs are in the OFF state.

- Buffered Inputs for Minimum Loading**
- Address Decoding on Chip**
- Address Access Time 15 ns Typ**
- Chip Select Access Time 8 ns Typ**
- Supply Current 80 mA Typ**

### Logic Symbol



$V_{CC}$  = Pin 20  
GND = Pin 10



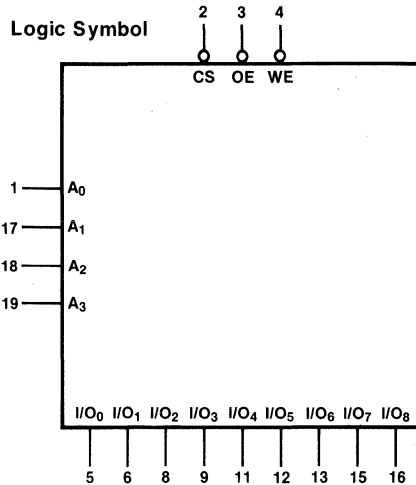
# 54F/74F312

## 144-Bit Random Access Memory (With Open-collector Outputs)

### Description

The 'F312 is a high-speed 144-bit Random Access Memory (RAM) organized as a 16-word by 9-bit array. Address inputs are buffered to minimize loading and are fully decoded on chip. The output buffers are active only in the Read mode when Chip Select ( $\overline{CS}$ ) and Output Enable ( $\overline{OE}$ ) are LOW, and Write Enable ( $\overline{WE}$ ) is HIGH; otherwise, the outputs are in the OFF state.

- Buffered Inputs for Minimum Loading**
- Address Decoding on Chip**
- Address Access Time 15 ns Typ**
- Chip Select Access Time 8 ns Typ**
- Supply Current 80 mA Typ**



VCC = Pin 20  
GND = Pin 10

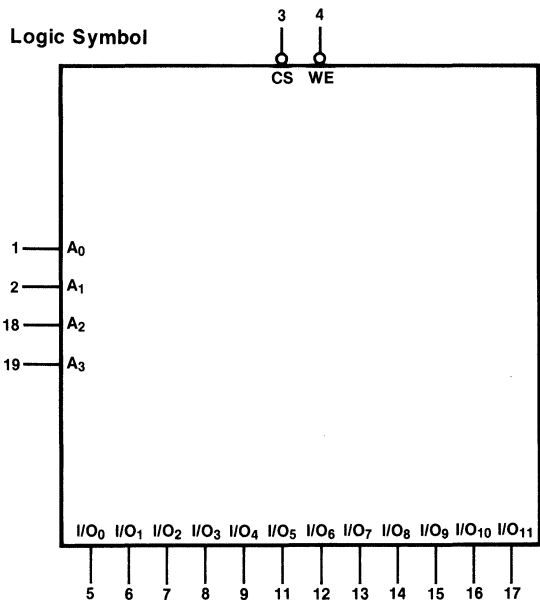
# 54F/74F313

## 192-Bit Random Access Memory (With Open-collector Outputs)

### Description

The 'F313 is a high-speed 192-bit Random Access Memory (RAM) organized as a 16-word by 12-bit array. Inputs are buffered to minimize loading and are fully decoded on chip. The output buffers are active only in the Read mode when Chip Select ( $\overline{CS}$ ) is LOW and Write Enable ( $\overline{WE}$ ) is HIGH; otherwise, the outputs are in the OFF state.

- Buffered Inputs for Minimum Loading**
- Address Decoding on Chip**
- Address Access Time 15 ns Typ**
- Chip Select Access Time 8 ns Typ**
- Supply Current 80 mA Typ**



VCC = Pin 20  
GND = Pin 10

# 54F/74F401

## Cyclic Redundancy Check Generator/Checker

### Description

The 'F401 Cyclic Redundancy Check (CRC) generator/checker implements the most widely used error detection scheme in serial digital data handling systems. On transmission, the data stream is encoded by dividing it by a set polynomial. The remainder is appended to the message as check bits. Upon reception, this data stream is divided by the same polynomial and if there is no remainder, there are no detectable errors.

### Eight Selectable Polynomials

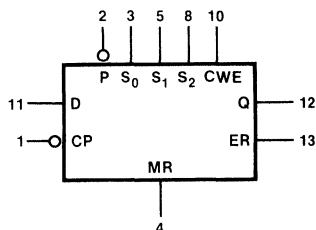
### Error Indicator

### More Efficient than Parity in Checking Errors

### High-speed Data Rate

### Supply Current 70 mA Typ

### Logic Symbol



VCC = Pin 14  
GND = Pin 7

# 54F/74F402

## Expandable Cyclic Redundancy Check Generator/Checker

### Description

The 'F402 expandable Cyclic Redundancy Check (CRC) generator/checker is an expandable version of the 'F401. It provides an advanced tool for the implementation of the most widely used error detection scheme in serial digital handling systems. A 4-bit control input selects one-of-six generator polynomials. The list of polynomials includes CRC-16, CRC-CCITT and Ethernet, as well as three other standard polynomials (56th order, 48th order, 32nd order). Individual clear and preset inputs are provided for floppy disk and other applications. The Error output indicates whether or not a transmission error has occurred. The CWG Control input inhibits feedback during check word transmission. The 'F402 is compatible with Fairchild Advanced Schottky TTL (FAST) devices and is fully compatible with all TTL families.

### Guaranteed 20 MHz Data Rate

### Six Selectable Polynomials

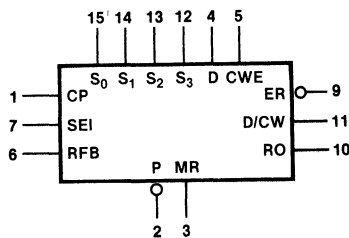
### Other Polynomials Available

### Separate Preset and Clear Controls

### Expandable Automatic Right Justification Error Output Open Collector Typical Applications

- Floppy and Other Disk Storage Systems
- Digital Cassette and Cartridge Systems
- Data Communication Systems

### Logic Symbol



VCC = Pin 16  
GND = Pin 8

# 54F/74F403

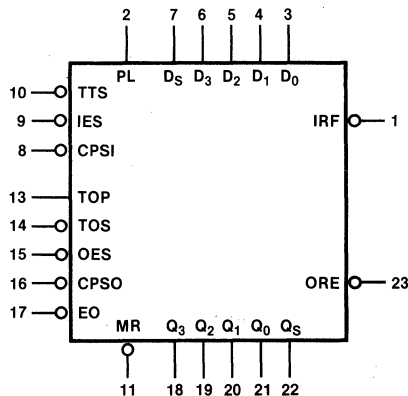
16 X 4 First-In First-Out  
Buffer Memory  
(With 3-State Outputs)

### Description

The 'F403 is an expandable fall-through type First-In First-Out (FIFO) buffer memory, optimized for high-speed disk or tape controllers and communication buffer applications. It is organized as 16 words by four bits and may be expanded to any number of words or bits (in multiples of 16 and 4 respectively). Data may be entered or extracted asynchronously in serial or parallel, allowing economical implementation of buffer memories.

- Serial or Parallel Data Rate 10 MHz**
- Serial or Parallel Input/Output**
- Expandable in Width and Depth**
- 3-State Outputs**
- Supply Current 115 mA Typ**

### Logic Symbol



V<sub>CC</sub> = Pin 24  
GND = Pin 12

# 54F/74F412

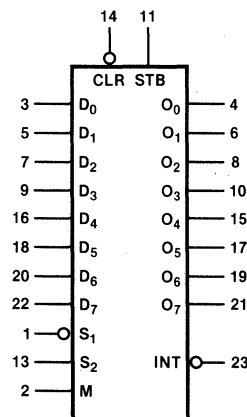
Multi-mode Buffered Latch  
(With 3-State Outputs)

### Description

The 'F412 is an 8-bit latch with 3-state output buffers and control and device selection logic. Also included is a status flip-flop for providing device-busy or request-interrupt commands. Separate Mode and Select inputs allow data to be stored with the outputs enabled or disabled. The device can also operate in a fully transparent mode. The 'F412 is the functional equivalent of the Intel 8212.

- 3-State Outputs**
- Status Flip-flop for Interrupt Commands**
- Asynchronous or Latched Receiver Modes**
- Select to Output Propagation Delay 10 ns Typ**
- Supply Current 43 mA Typ**

### Logic Symbol



V<sub>CC</sub> = Pin 24  
GND = Pin 12

## 54F/74F413

### 64 X 4 First-In First-Out Buffer Memory

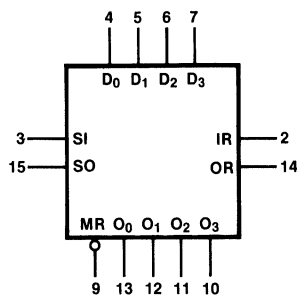
(With Serial and Parallel I/O)

#### Description

The 'F413 is an expandable fall-through type high-speed First-In First-Out (FIFO) buffer memory organized as 64 words by four bits. The 4-bit input and output registers record and transmit, respectively, asynchronous data in either serial or parallel form. Control pins on the input and output allow for handshaking and expansion. The 4-bit wide, 62-bit deep fall-through stack has self-contained control logic. The outputs are in the high-impedance state when the Output Enable is HIGH.

**Separate Input and Output Clocks**  
**Serial or Parallel Input and Output**  
**Expandable without External Logic**  
**15 MHz Data Rate**  
**Supply Current 115 mA Typ**

#### Logic Symbol



V<sub>CC</sub> = Pin 16  
GND = Pin 8

5

## 54F/74F416

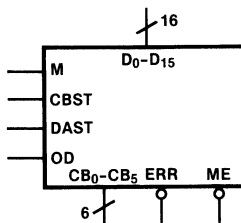
### 16-Bit Memory Error Detection And Correction Circuit

#### Description

The 'F416 memory Error Detection And Correction (EDAC) circuit contains the logic to generate six check bits on a 16-bit data field, according to a modified Hamming code. The check bits are then stored in memory with the data word. On a subsequent read from memory, the device will detect and correct any single-bit data error, and detect any double-bit error. The 'F416 is a 16-bit version of the 'F418.

**Increases Memory System Reliability**  
**Corrects Single-bit Errors**  
**Detects Double-bit Errors**

#### Logic Symbol



# 54F/74F418

## 32-Bit Memory Error Detection And Correction Circuit

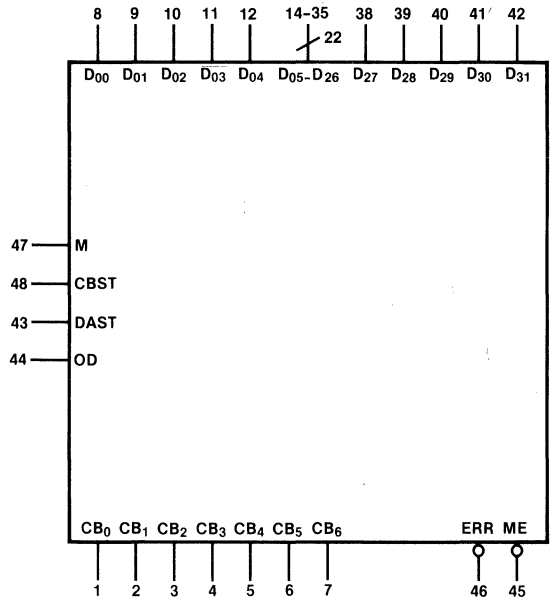
### Description

The 'F418 memory Error Detection And Correction (EDAC) circuit contains the logic to generate seven check bits on a 32-bit data field, according to a modified Hamming code. The check bits are then stored in memory with the data word. On a subsequent read from memory, the device will detect and correct any single-bit data error, and detect any double-bit error.

The 'F418 is fully compatible with all TTL families. Data and check-bit signals are bidirectional 3-state lines.

**Increases Memory System Reliability**  
**Corrects Single-bit Errors in 60 ns**  
**Detects Double-bit Errors in 65 ns**

### Logic Symbol



V<sub>CC</sub> = Pin 36  
GND = Pins 13, 37

# 54F/74F430

## Cyclic Redundancy Checker/Corrector

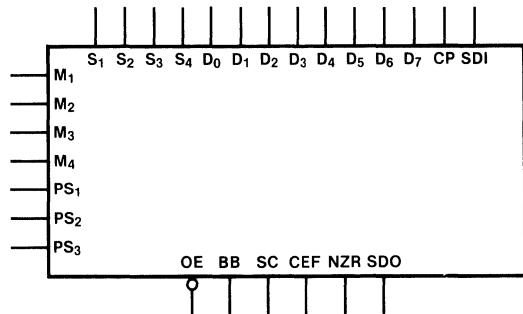
### Description

The 'F430 Cyclic Redundancy Checker/Corrector (CRCC) is a serial burst-error detection/correction circuit, using a 32-order polynomial selected by internal Read Only Memory (ROM). When used at the data transmission source, the 'F430 generates a cyclic redundancy check code and appends it to a data block transmission. When the device is placed at the receiving end of a transmission, it is used to verify the integrity of the data block that now contains the appended check code. Should an error be detected, under user control, the device can be made to correct the bits in error. The CRCC is used in high-performance serial data transmission applications such as disk and tape controllers, as well as communications equipment and serial data interfaces between mainframes and peripherals.

**Eight Different Polynomials, up to 32nd Order**  
(e.g. Ethernet)

**Clocking Rate 25 MHz**  
**28-Pin Package**

### Logic Symbol



5

# 54F/74F432

## Multi-mode Buffered Latch (With 3-State Outputs)

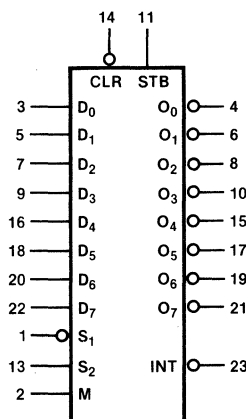
### Description

The 'F432 is an 8-bit latch with 3-state output buffers and control and device selection logic. Also included is a status flip-flop for providing device-busy or request-interrupt commands. Separate Mode and Select inputs allow data to be stored with the outputs enabled or disabled. The device can also operate in a fully transparent mode.

The 'F432 is the functional equivalent of the Intel 8212, but with inverting outputs.

**3-State Inverting Outputs**  
**Status Flip-flop for Interrupt Commands**  
**Asynchronous or Latched Receiver Modes**  
**Select to Output Propagation Delay 10 ns**  
**Supply Current 43 mA Typ**

### Logic Symbol



V<sub>CC</sub> = Pin 24  
GND = Pin 12

# 54F/74F433

## 64 x 4 First-In First-Out Buffer Memory (With 3-State Outputs)

### Description

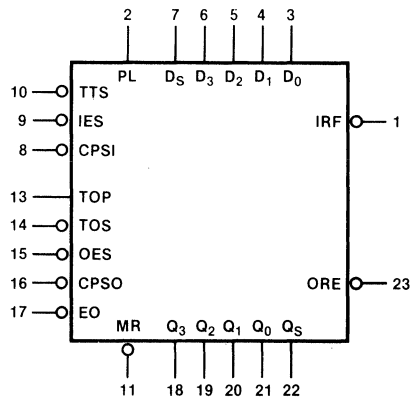
The 'F433 is an expandable fall-through type First-In First-Out (FIFO) buffer memory, optimized for high-speed disk or tape controllers and communication buffer applications. It is organized as 64 words by four bits and may be expanded to any number of words or bits (in multiples of four). Data may be entered or extracted asynchronously in serial or parallel, allowing economical implementation of buffer memories.

The 'F433 has 3-state outputs for added versatility and is fully compatible with all TTL families.

### 64 x 4 Version of 'F403

**Serial or Parallel Input/Output**  
**Expandable without External Logic**  
**Serial or Parallel Data Rate 10 MHz**  
**24-Pin Package**

### Logic Symbol



VCC = Pin 24  
 GND = Pin 12

# 54F/74F500

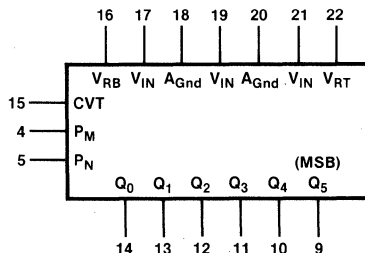
## 6-Bit Analog-to-Digital Converter

### Description

The 'F500 is a 6-bit, fully parallel analog-to-digital converter capable of sampling at rates from 0 to 50 MHz. Conversion is accomplished by 64 comparators spaced one quanta apart on a voltage reference ladder. All comparators measure the analog input against their reference simultaneously. The most significant comparator that finds the analog input to be greater than its reference has its output encoded to a 6-bit, active-HIGH binary number, stored in latches. Two polarity control inputs are provided: P<sub>M</sub> complements the most significant output bit and P<sub>N</sub> complements the lesser five output bits. The circuit operates from +5.0 V and -6.0 V supplies and has separate digital and analog grounds. Both ends of the reference ladder are brought out, one to V<sub>RT</sub> (nominally zero volts) and the other to V<sub>RB</sub> (nominally -1.0 V).

**No Sample and Hold Required**  
**Sampling Rate 40 MHz Typ**  
**Aperture Time 4.0 ns Typ**  
**VCC Supply Current 20 mA Typ**  
**VEE Supply Current 102 mA Typ**

### Logic Symbol



VCC = Pin 7  
 VEE = Pins 1, 6  
 DGnd = Pin 8

# 54F/74F505

## 8-Bit Analog-to-Digital Converter

### Description

The 'F505 is an 8-bit A-to-D converter using the successive approximation technique. It contains an 8-bit successive approximation shift register connected internally to an 8-bit D-to-A converter. The converter output drives one input of an on-chip analog comparator. The 'F505 is intended for use where the speed of flash converters is not needed. Its handshaking facilities and 3-state outputs make it microprocessor compatible.

### 8-Bit Resolution

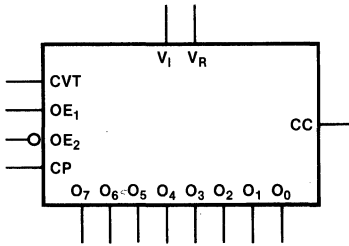
Single 5 V Power Supply Required

Input Range 0.2 V

Conversion Time 200 ns Typ

Clock Frequency 40 MHz Typ

### Logic Symbol



5

# 54F/74F525

## 16-Stage Programmable Counter/Timer

### Description

The 'F525 is a 16-bit multimode programmable timer, divider, and frequency generator. It incorporates a 16-bit presettable counter, a 16-bit latch, crystal oscillator circuit and control circuitry. Modes include programmable timer, divider, one shot and terminal count interrupt.

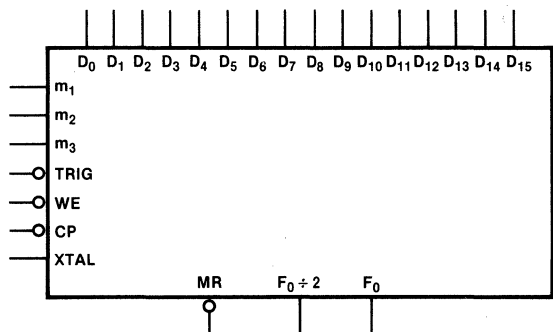
### 28-Pin Package

16-Stage Divider

Clock Frequency 50 MHz Typ

Supply Current 100 mA Typ

### Logic Symbol





# 54F/74F559

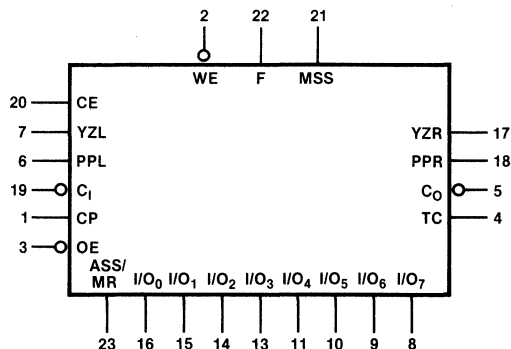
## Expandable 8-Bit Twos Complement Multiplier/Divider (With 3-State Outputs)

### Description

The '559 implements fast signed twos complement multiplication and division as an asynchronous peripheral in microprocessor and minicomputer systems. It contains an 8-bit ALU, three 8-bit registers, a 4-bit sequence counter and the control logic necessary to perform multiply, rounded multiply, fractional divide and integer divide operations. The two 8-bit operands are entered successively at the I/O ports, whereupon the circuit operates internally at a rate determined by an externally applied clock frequency of up to 25 MHz. Upon completion, and upon command, results are presented at the I/O ports in successive 8-bit words. Linking inputs and outputs are provided for expansion to longer words by using two or more multipliers operating on the same 8-bit bus.

- Signed Twos Complement Arithmetic Increases Processor Efficiency**
- Low System Parts Count**
- Expandable in 8-Bit Increments**
- 8-Bit Bus Oriented 3-State I/O**
- 16-Bit Multiply in 1.2  $\mu$ s Typ**
- 16-Bit Divide in 1.6  $\mu$ s Typ**

### Logic Symbol



V<sub>CC</sub> = Pin 24  
GND = Pin 12

# 54F/74F579

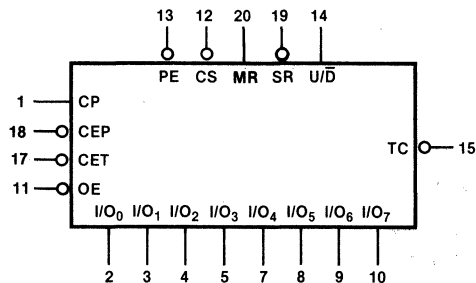
## 8-Bit Bidirectional Binary Counter

### Description

The '579 is a fully synchronous 8-stage up/down counter with multiplexed 3-state I/O ports for bus oriented applications. It features a preset capability for programmable operation, carry lookahead for easy cascading and a U/D input to control the direction of counting. All state changes, whether in counting or parallel loading, are initiated by the rising edge of the clock.

- Multiplexed 3-state I/O Ports**
- Space Saving 20-Pin Package**
- Built-in Lookahead Carry Capability**
- Count Frequency 100 MHz Typ**
- Supply Current 75 mA Typ**

### Logic Symbol



V<sub>CC</sub> = Pin 16  
GND = Pin 6

# 54F/74F582

## 4-Bit BCD Arithmetic Logic Unit

### Description

The 'F582 is a 24-pin expandable Arithmetic Logic Unit (ALU) that performs two arithmetic operations (A plus B, A minus B), compare (A equals B), and binary to BCD conversion. In addition to a ripple carry output, carry Propagate ( $\overline{P}$ ) and Generate ( $\overline{G}$ ) outputs are provided for use with the 'F182 carry lookahead generator for high-speed expansion to higher decades. It is functionally equivalent to the 82S82.

### 24-Pin Package

**Performs Four BCD Functions**

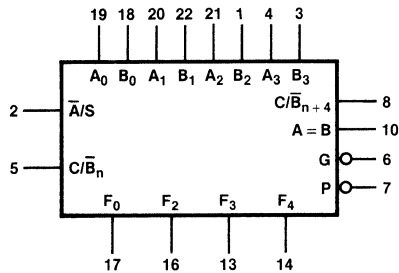
**$\overline{P}$  and  $\overline{G}$  Outputs for High-speed Expansion**

**Add/Subtract Delay 14 ns Typ**

**Lookahead Delay 12 ns Typ**

**Supply Current 55 mA Typ**

### Logic Symbol



V<sub>CC</sub> = Pin 24

GND = Pin 12

5

# 54F/74F583

## 4-Bit BCD Adder

### Description

The 'F583 high-speed 4-bit BCD full adder with internal carry lookahead accepts two 4-bit decimal numbers (A<sub>0</sub>–A<sub>3</sub>, B<sub>0</sub>–B<sub>3</sub>) and a Carry Input (C<sub>n</sub>). It generates the decimal sum outputs (S<sub>0</sub>–S<sub>3</sub>), and a Carry Output (C<sub>n+4</sub>) if the sum is greater than 9. The 'F583 is the functional equivalent of the 82S83.

**Adds Two Decimal Numbers**

**Full Internal Lookahead**

**Fast Ripple Carry for Economical Expansion**

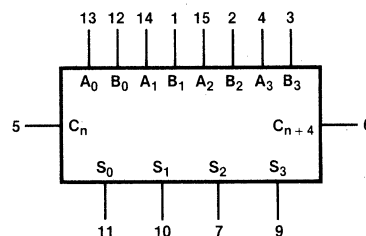
**Sum Output Delay Time 11 ns Typ**

**Ripple Carry Delay Time 6 ns Typ**

**Input to Ripple Delay Time 9 ns Typ**

**Supply Current 50 mA Typ**

### Logic Symbol



V<sub>CC</sub> = Pin 16

GND = Pin 8

# 54F/74F604

# 54F/74F606

## Dual Octal Registers (With Multiplexed 3-State Outputs)

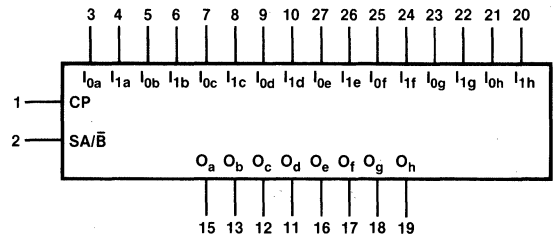
### Description

The 'F604 and 'F606 contain 16 D-type edge-triggered flip-flops with common clock and individual data inputs. Organized as 8-bit A and B registers, the flip-flop outputs are connected by pairs to eight 2-input multiplexers. A Select ( $SA/\bar{B}$ ) input determines whether the A or B register contents are multiplexed to the eight 3-state outputs. Data entered from the  $I_0$  inputs are selected when  $SA/\bar{B}$  is LOW; data from the  $I_1$  inputs are selected when  $SA/\bar{B}$  is HIGH. Data enters the flip-flops on the rising edge of the Clock (CP) input, which also controls the 3-state outputs. The outputs are enabled when CP is HIGH and disabled when CP is LOW.

These functions are well suited for receiving 16-bit simultaneous data and transmitting it as two sequential 8-bit words. The 'F606 has glitch-free outputs; the 'F604 has reduced propagation delays.

**Stores 16-Bit Wide Data Inputs**  
**Multiplexed 8-Bit Outputs**  
**High-speed or Glitch-free Version**  
**3-State Outputs**  
**Propagation Delay 10 ns Typ**  
**Power Supply Current 140 mA Typ**

### Logic Symbol



VCC = Pin 28  
 GND = Pin 14

# 54F/74F605

# 54F/74F607

## Dual Octal Registers (With Multiplexed Open-collector Outputs)

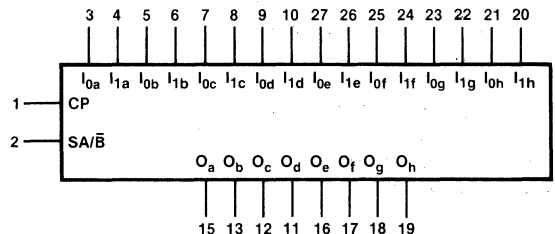
### Description

The 'F605 and 'F607 contain 16 D-type edge-triggered flip-flops with common clock and individual data inputs. Organized as 8-bit A and B registers, the flip-flop outputs are connected by pairs to eight 2-input multiplexers. A Select ( $SA/\bar{B}$ ) input determines whether the A or B register contents are multiplexed to the eight open-collector outputs. Data entered from the  $I_0$  inputs are selected when  $SA/\bar{B}$  is LOW; data from the  $I_1$  inputs are selected when  $SA/\bar{B}$  is HIGH. Data enters the flip-flops on the rising edge of the Clock (CP) input, which also controls the open-collector outputs. The outputs are enabled when CP is HIGH and disabled when CP is LOW.

These functions are well suited for receiving 16-bit simultaneous data and transmitting it as two sequential 8-bit words. The 'F607 has glitch-free outputs; the 'F605 has reduced propagation delays.

**Stores 16-Bit Wide Data Inputs**  
**Multiplexed 8-Bit Outputs**  
**High-speed or Glitch-free Version**  
**Open-collector Outputs**  
**Propagation Delay 10 ns Typ**  
**Power Supply Current 140 mA Typ**

### Logic Symbol



VCC = Pin 28  
 GND = Pin 14

# 54F/74F610

## Memory Mapper

(With 3-State Outputs and Output Latches)

### Description

The 'F610 memory mapper is designed to expand the address capability of a Central Processing Unit (CPU) by eight bits. The device contains 16 map registers, each containing 12 bits, that are loaded by the CPU. Subsequently, the four most significant bits of the memory address select one of the 16 registers. The 12 output bits, plus the four least significant memory address bits, form the expanded address. In this mode the 'F610 output stages may be transparent or latched. The addressable memory space is increased by periodically reloading the map registers.

In the pass mode the address bits on the register select inputs appear as the most significant bits at the map outputs, with LOW levels appearing on the other bit positions.

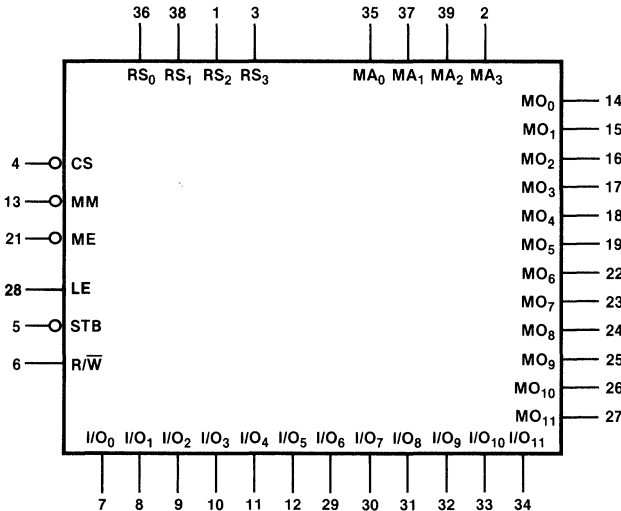
### Increases Addressing Capability by Eight Bits

#### Designed for Paged Memory Mapping

#### Output Latches

#### 3-State Outputs

### Logic Symbol



V<sub>CC</sub> = Pin 40  
GND = Pin 20

# 54F/74F611

## Memory Mapper

(With Open-collector Outputs and Output Latches)

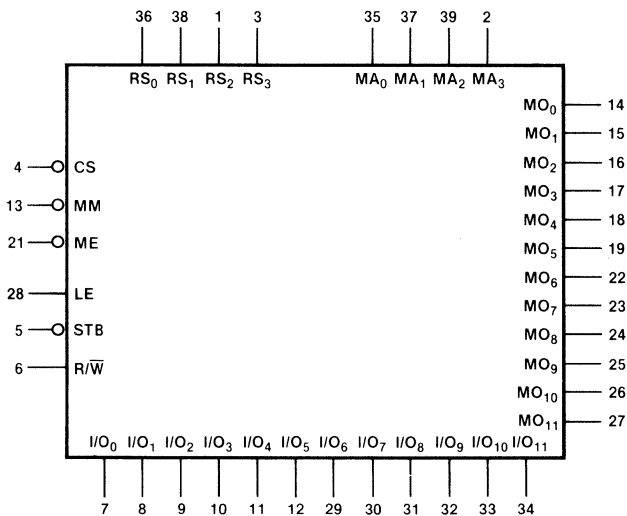
### Description

The 'F611 memory mapper is designed to expand the address capability of a Central Processing Unit (CPU) by eight bits. The device contains 16 map registers, each containing 12 bits, that are loaded by the CPU. Subsequently, the four most significant bits of the memory address select one of the 16 registers. The 12 output bits, plus the four least significant memory address bits, form the expanded address. In this mode the 'F611 output stages may be transparent or latched. The addressable memory space is increased by periodically reloading the map registers.

In the pass mode the address bits on the register select inputs appear as the most significant bits at the map outputs, with LOW levels appearing on the other bit positions.

**Increases Addressing Capability by Eight Bits**  
**Designed for Paged Memory Mapping**  
**Output Latches**  
**Open-collector Outputs**

### Logic Symbol



V<sub>CC</sub> = Pin 40  
GND = Pin 20

# 54F/74F612

## Memory Mapper

(With 3-State Outputs)

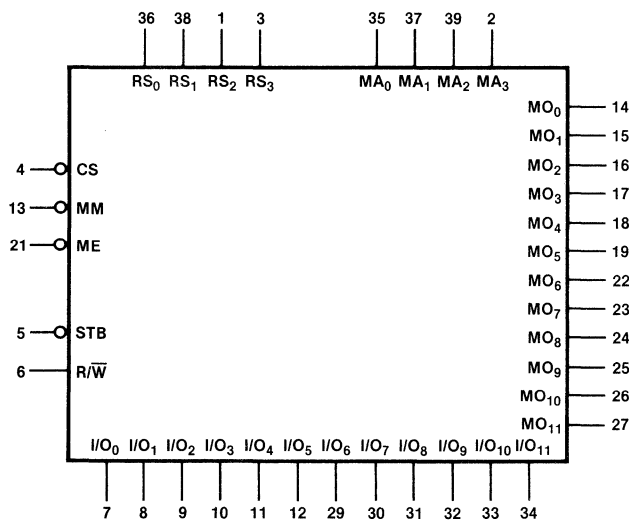
### Description

The 'F612 memory mapper is designed to expand the address capability of a Central Processing Unit (CPU) by eight bits. The device contains 16 map registers, each containing 12 bits, that are loaded by the CPU. Subsequently, the four most significant bits of the memory address select one of the 16 registers. The 12 output bits, plus the four least significant memory address bits, form the expanded address. In this mode the 'F612 output stages are transparent. The addressable memory space is increased by periodically reloading the map registers.

In the pass mode the address bits on the register select inputs appear as the most significant bits at the map outputs, with LOW levels appearing on the other bit positions.

**Increases Addressing Capability by Eight Bits**  
**Designed for Paged Memory Mapping**  
**3-State Outputs**

### Logic Symbol



VCC = Pin 40  
GND = Pin 20

# 54F/74F613

## Memory Mapper

(With Open-collector Outputs)

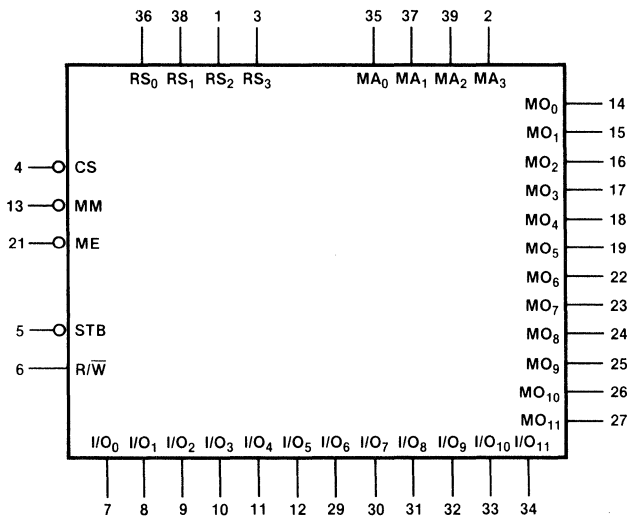
### Description

The 'F613 memory mapper is designed to expand the address capability of a Central Processing Unit (CPU) by eight bits. The device contains 16 map registers, each containing 12 bits, that are loaded by the CPU. Subsequently, the four most significant bits of the memory address select one of the 16 registers. The 12 output bits, plus the four least significant memory address bits, form the expanded address. In this mode the 'F613 output stages are transparent. The addressable memory space is increased by periodically reloading the map registers.

In the pass mode the address bits on the register select inputs appear as the most significant bits at the map outputs, with LOW levels appearing on the other bit positions.

**Increases Addressing Capability by Eight Bits**  
**Designed for Paged Memory Mapping**  
**Open-collector Outputs**

### Logic Symbol



V<sub>CC</sub> = Pin 40  
GND = Pin 20

# 54F/74F630

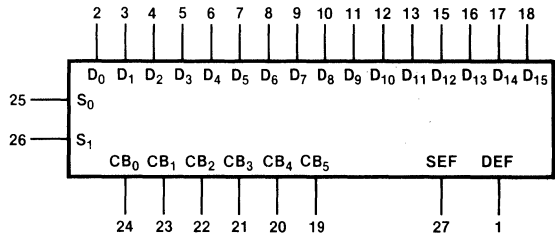
## 16-Bit Error Detection And Correction Circuit (With 3-State Outputs)

### Description

The 'F630 is a 16-bit Error Detection And Correction (EDAC) circuit with 3-state outputs. It uses a modified Hamming code to generate a 6-bit check word from a 16-bit data word. This check word is stored along with the data word during the memory write cycle. During the memory read cycle, the 22-bit word from the memory is processed by the EDAC to determine if errors have occurred in memory.

- Detects and Corrects Single-bit Errors**
- Detects and Flags Dual-bit Errors**
- Generates Check Word in 20 ns Typ**
- Flags Errors in 25 ns Typ**
- Supply Current 120 mA Typ**

### Logic Symbol



V<sub>CC</sub> = Pin 28  
GND = Pin 14

# 54F/74F631

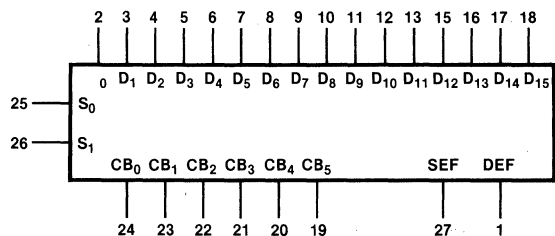
## 16-Bit Error Detection And Correction Circuit (With Open-collector Outputs)

### Description

The 'F631 is a 16-bit Error Detection And Correction (EDAC) circuit with open-collector outputs. It uses a modified Hamming Code to generate a 6-bit check word from a 16-bit data word. This check word is stored along with the data word during the memory write cycle. During the memory read cycle, the 22-bit word from the memory is processed by the EDAC to determine if errors have occurred in memory.

- Detects and Corrects Single-bit Errors**
- Detects and Flags Dual-bit Errors**
- Generates Check Word in 20 ns Typ**
- Flags Errors in 25 ns Typ**
- Supply Current 120 mA Typ**

### Logic Symbol



V<sub>CC</sub> = Pin 28  
GND = Pin 14



# 54F/74F676

## 16-Bit Shift Register (Serial/Parallel In, Serial Out)

### Description

The 'F676 contains 16 flip-flops with provision for synchronous parallel or serial entry and serial output. When the Mode (M) input is HIGH, information present on the parallel data (P<sub>0</sub>-P<sub>15</sub>) inputs is entered on the falling edge of the Clock Pulse ( $\overline{CP}$ ) input signal. When M is LOW, data is shifted out of the most significant bit position while information present on the Serial (SI) input shifts into the least significant bit position. A HIGH signal on the Chip Select ( $\overline{CS}$ ) input prevents both parallel and serial operations.

### 16-Bit Parallel-to-Serial Conversion

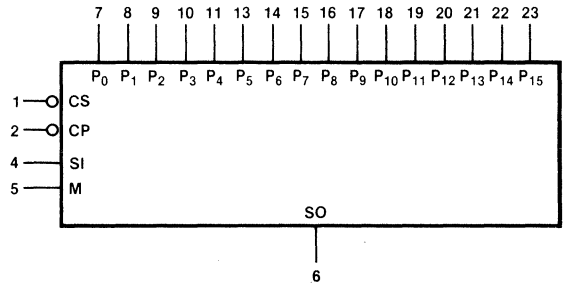
### 16-Bit Serial-in, Serial-out

### Chip Select Control

### Power Supply Current 53 mA Typ

### Shift Frequency 100 MHz Typ

### Logic Symbol



V<sub>CC</sub> = Pin 24  
GND = Pin 12

# 54F/74F779

## 8-Bit Bidirectional Binary Counter

### Description

The 'F779 is a fully synchronous 8-stage up/down counter with multiplexed 3-state I/O ports for bus oriented applications. All control functions (hold, count up, count down, synchronous load) are controlled by two mode pins (S<sub>0</sub>, S<sub>1</sub>). The device also features carry lookahead for easy cascading. All state changes are initiated by the rising edge of the clock.

### Multiplexed 3-State I/O Ports

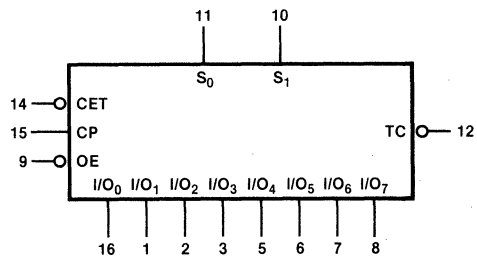
### 16-Pin Package for High Packaging Density

### Built-in Lookahead Carry Capability

### Count Frequency 100 MHz Typ

### Supply Current 80 mA Typ

### Logic Symbol



V<sub>CC</sub> = Pin 13  
GND = Pin 4

# 54F/74F784

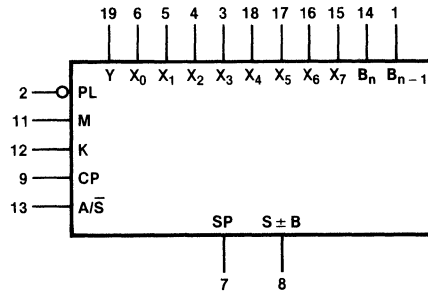
## 8-Bit Serial/Parallel Multiplier (With Adder/Subtractor)

### Description

The 'F784 is a serial  $n \times 8$ -bit multiplier with a final stage adder/subtractor for optional use in adding a B bit to obtain  $S \pm B$ . A 'B-1' bit can also be added via an internal flip-flop to achieve a 1-bit delay. The x word is parallel loaded (eight bits wide) into latches and the y word is clocked in serially from a shift register. The 'F784 is particularly useful for high-speed digital filtering or butterfly networks in fast Fourier transforms.

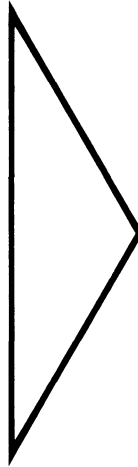
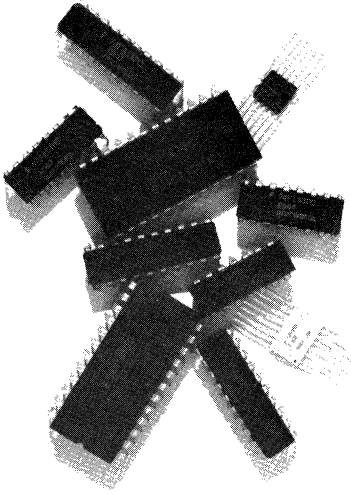
- Twos Complement Multiplication**
- Cascadable for any Number of Bits**
- Full Adder and B - 1 Input Included for Maximum Flexibility**
- Maximum Clock Frequency 100 MHz Typ**
- Supply Current 78 mA Typ**

### Logic Symbol

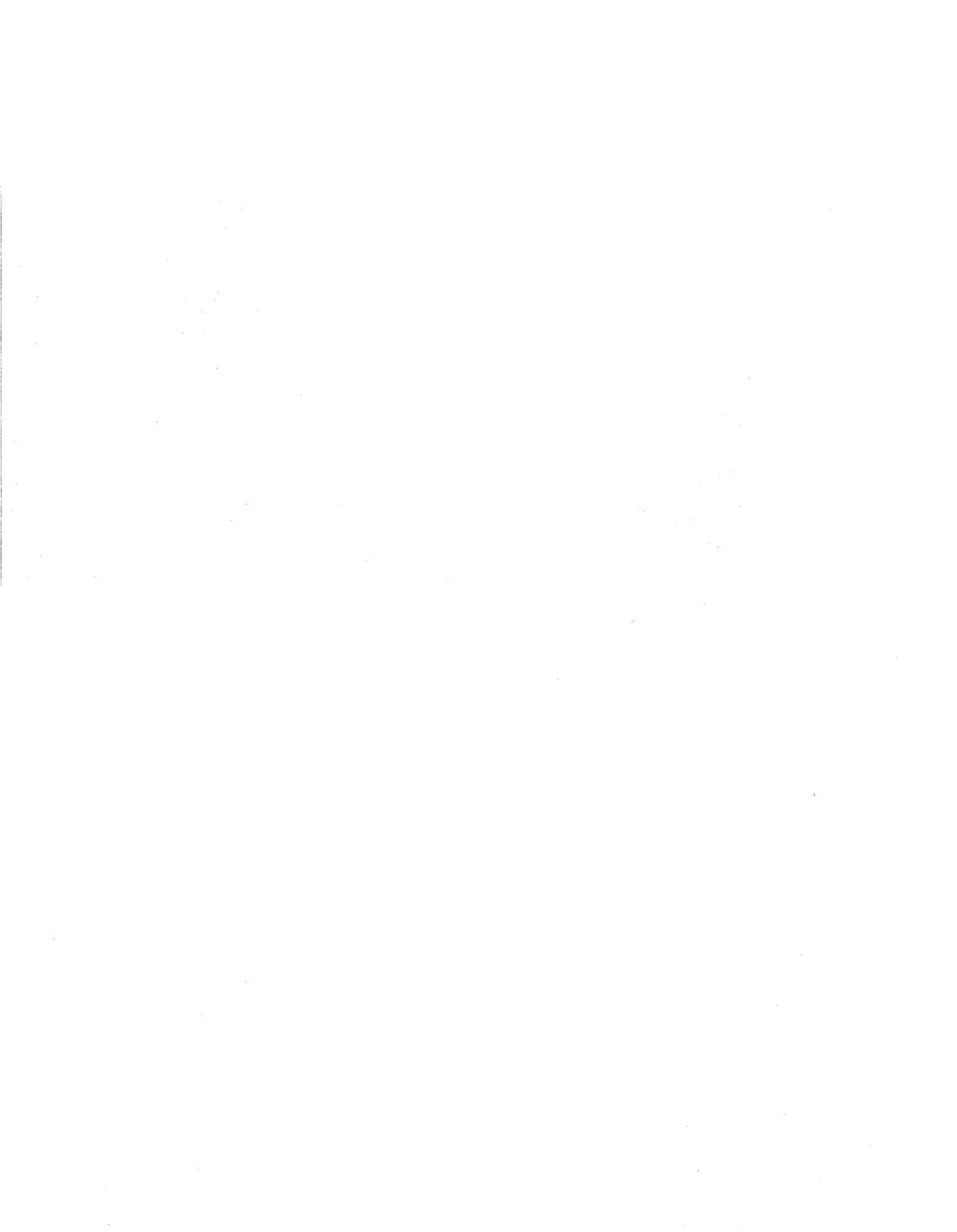


V<sub>CC</sub> = Pin 20  
GND = Pin 10





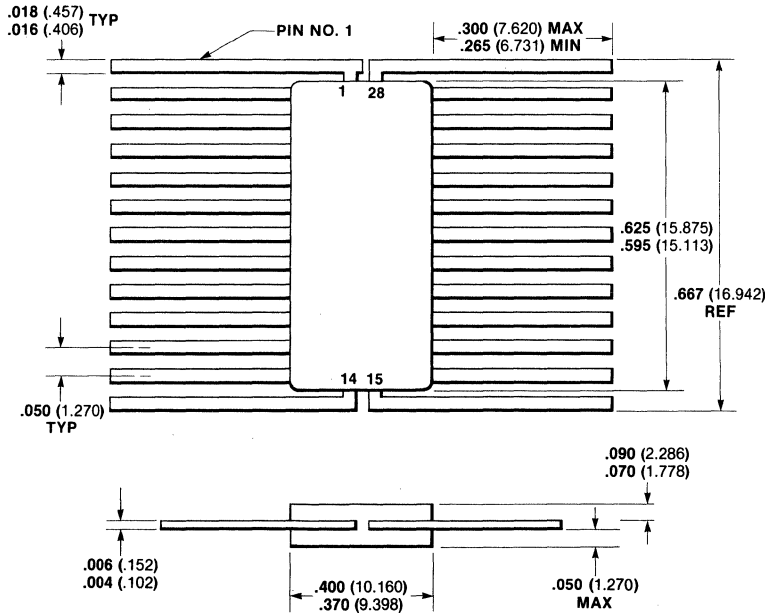
<b>Product Index and Selection Guide</b>	<b>1</b>
<b>Circuit Characteristics</b>	<b>2</b>
<b>Ratings, Specifications and Waveforms</b>	<b>3</b>
<b>Data Sheets</b>	<b>4</b>
<b>New Products</b>	<b>5</b>
<b>Ordering Information and Package Outlines</b>	<b>6</b>
<b>Sales Offices, Representatives and Distributor Locations</b>	<b>7</b>





## 2E

### 28-Pin Ceramic Flatpak

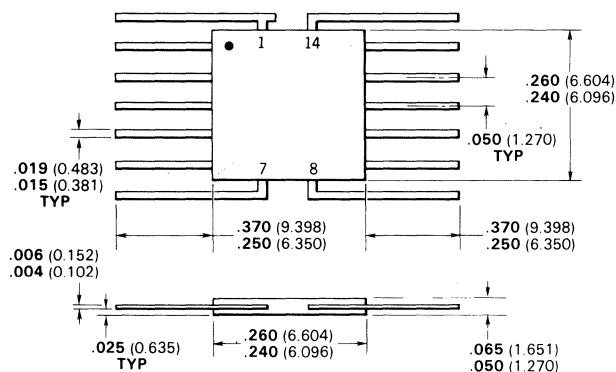


#### Notes

Pins are tin plated alloy 42 or equivalent  
Base and cap are alumina, black  
Cavity size is **.200 x .300** (5.08 x 7.62)  
Package weight is 1.0 gram

## 31

### 14-Pin Ceramic Flatpak



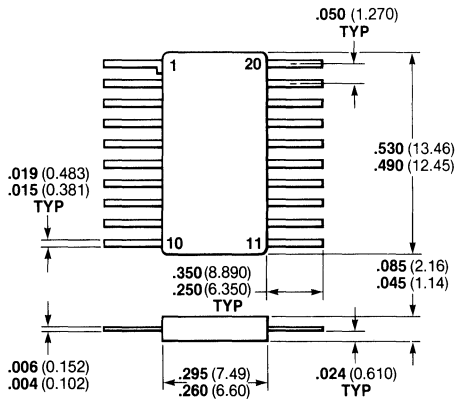
#### Notes

Pins are tin-plated 42 alloy  
Hermetically sealed alumina package  
Pin 1 orientation may be either tab or dot  
Cavity size is **.130 x .130** (3.30 x 3.30)  
Package weight is 0.26 gram

All dimensions are in inches **bold** and (millimeters)

# 4D

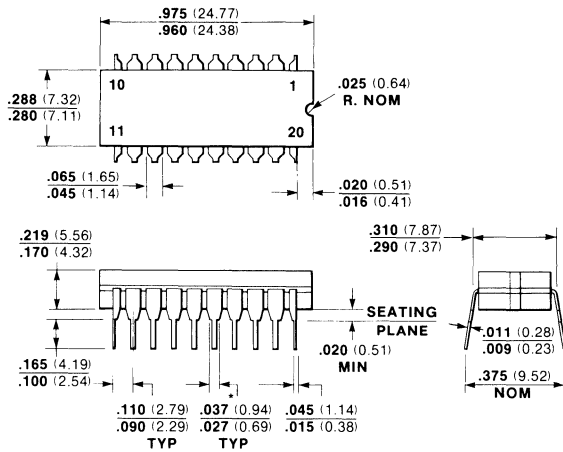
## 20-Pin Ceramic Flatpak



**Notes**  
 Pins are tin-plated alloy 42  
 Cap and base are Al<sub>2</sub>O<sub>3</sub>  
 Package weight is 0.8 gram

# 4E

## 20-Pin Ceramic Dual In-line

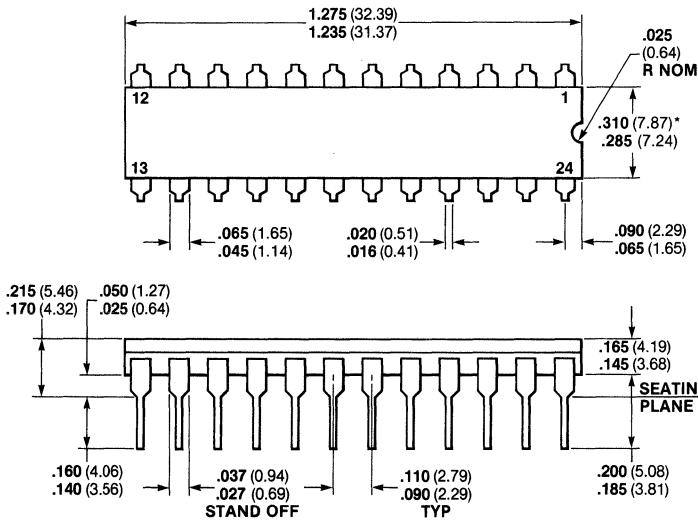


**Notes**  
 Pins are tin-plated kovar or nickel alloy 42  
 Pins are intended for insertion in hole rows on **.300** (7.62) centers  
 They are purposely shipped with "positive" misalignment to facilitate insertion  
 Board-drilling dimensions should equal your practice for **.030** (0.76) diameter pins  
 Hermetically sealed alumina package (black)  
 Cavity size is **.140 x .250** (3.56 x 6.35)  
 \*The **.037-.027** (0.94-0.69) dimension does not apply to the corner pins  
 Package weight is 2.4 grams



# 4H

## 24-Pin Slim Ceramic Dual In-line

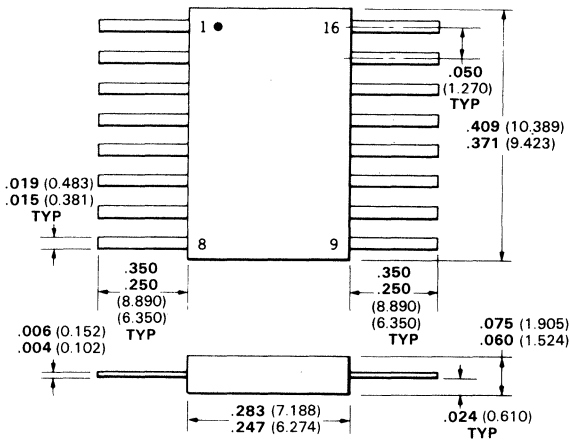


### Notes

- Pins are tin-plated 42 alloy or equivalent
- Package material is alumina
- Pins are intended for insertion in rows on .300 (7.62) centers
- They are purposely shipped with "positive" misalignment to facilitate insertion
- Cavity size is .160 x .250 (4.064 x 6.350)
- Package weight is 3.9 grams
- \*These dimensions include misalignment, glass overrun, etc.

# 4L

## 16-Pin Ceramic Flatpak



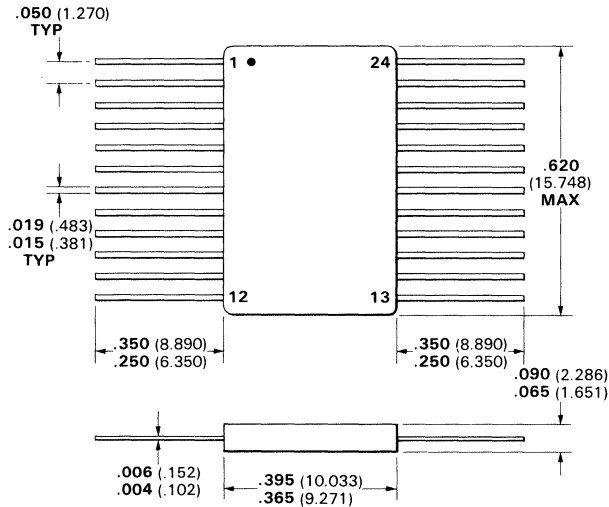
### Notes

- Pins are alloy 42
- Package weight is 0.4 gram
- Hermetically sealed beryllia package

All dimensions are in inches **bold** and (millimeters)

# 4M

## 24-Pin Ceramic Flatpak



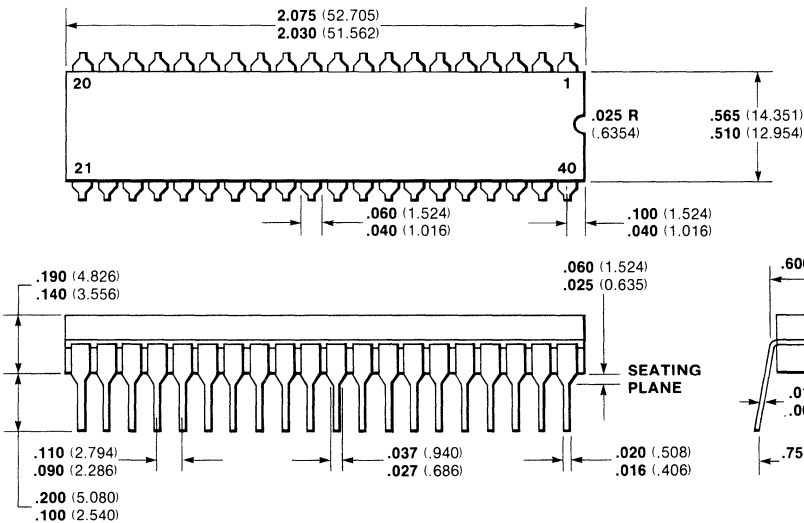
### Notes

- Pins are tin-plated 42 alloy
- Cap material is alumina
- Base material is beryllia
- Cavity size is .222 x .250 (5.64 x 6.35)
- Package weight is 0.8 gram

6

# 4W

## 40-Pin Ceramic Dual In-line



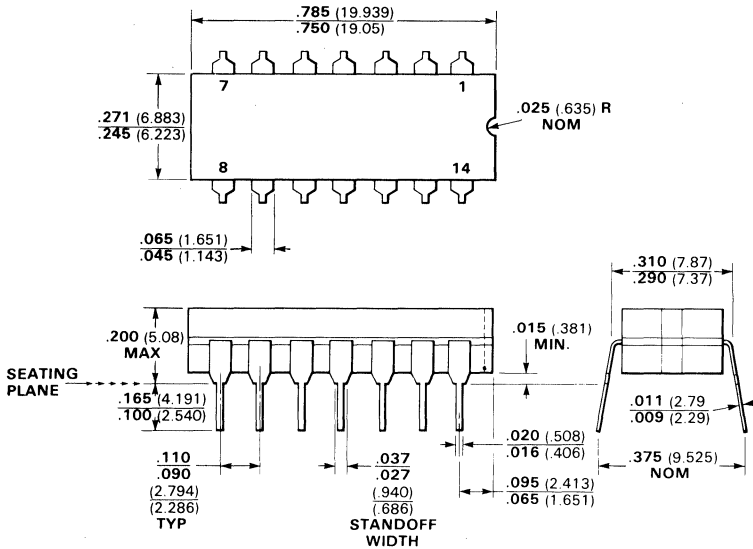
### Notes

- Pin material is kovar
- Package material is alumina
- Sealing material is vitreous glass
- Cavity size is .260 x .270 (6.604 x 6.858)
- Package weight is 12 grams

All dimensions are in inches **bold** and (millimeters)

# 6A

## 14-Pin Ceramic Dual In-line

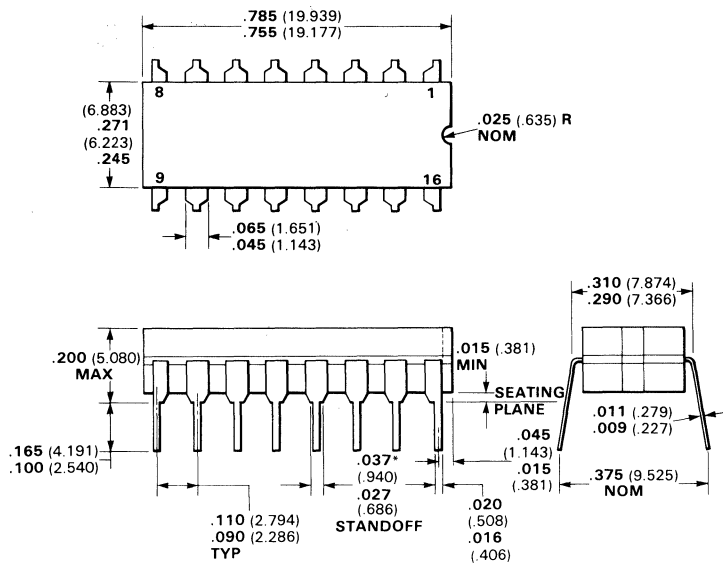


### Notes

Pins are intended for insertion in hole rows on **.300** (7.620) centers  
 They are purposely shipped with "positive" misalignment to facilitate insertion  
 Board-drilling dimensions should equal your practice for **.020** (0.508) diameter pin  
 Pins are alloy 42  
 Package weight is 2.0 grams

# 6B

## 16-Pin Ceramic Dual In-line



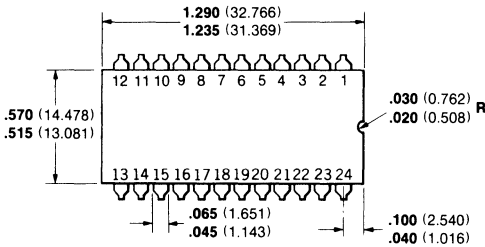
### Notes

Pins are tin-plated 42 alloy  
 Pins are intended for insertion in hole rows on **.300** (7.62) centers  
 They are purposely shipped with "positive" misalignment to facilitate insertion  
 Board-drilling dimensions should equal your practice for **.020** (0.51) diameter pin  
 Hermetically sealed alumina package  
 Cavity size is **.110 x .140** (2.79 x 3.56)  
 Package weight is 2.0 grams  
 \*The **.037-.027** (0.94-0.69) dimension does not apply to the corner pins

All dimensions are in inches **bold** and (millimeters)

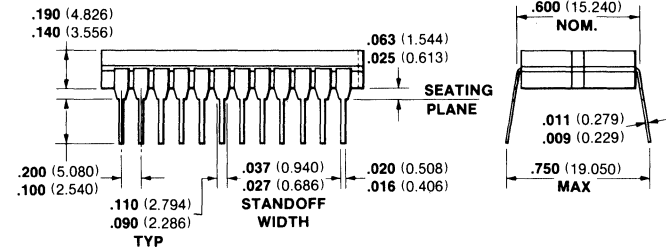
# 6N

## 24-Pin Ceramic Dual In-line



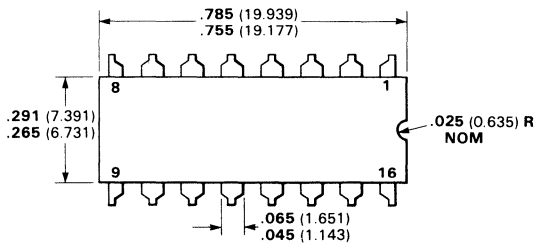
### Notes

Pins are tin-plated 42 alloy  
 Package material is alumina  
 Pins are intended for insertion in hole rows on **.600** (15.24) centers  
 They are purposely shipped with "positive" misalignment to facilitate insertion  
 Cavity size is **.230 x .230** (5.84 x 5.84)  
 Package weight is 6.5 grams



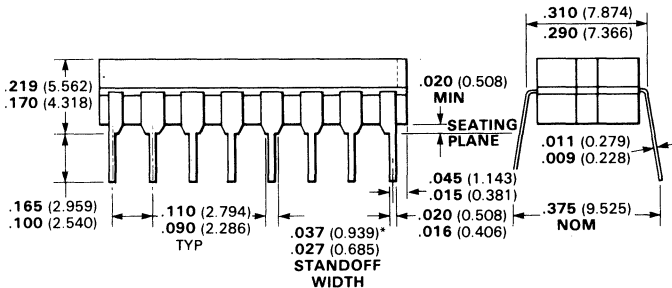
# 7B

## 16-Pin Ceramic Dual In-line



### Notes

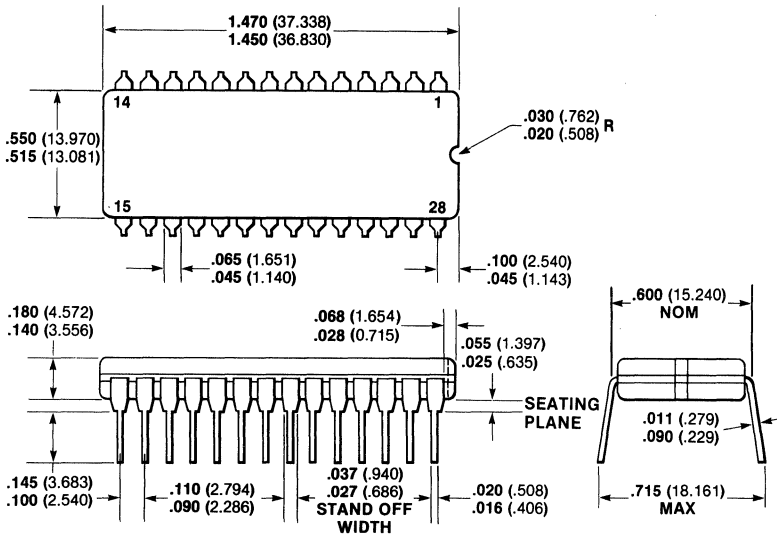
Pins are tin-plated 42 alloy  
 Pins are intended for insertion in hole rows on **.300** (7.62) centers  
 They are purposely shipped with "positive" misalignment to facilitate insertion  
 Board-drilling dimensions should equal your practice for **.020** (0.51) diameter pin  
 Hermetically sealed alumina package  
 Cavity size is **.130 x .230** (3.302 x 5.842)  
 \*The **.037-.027** (0.94-.69) dimension does not apply to the corner pins  
 Package weight is 2.2 grams



All dimensions are in inches **bold** and (millimeters)

# 8S

## 28-Pin Ceramic Dual In-line

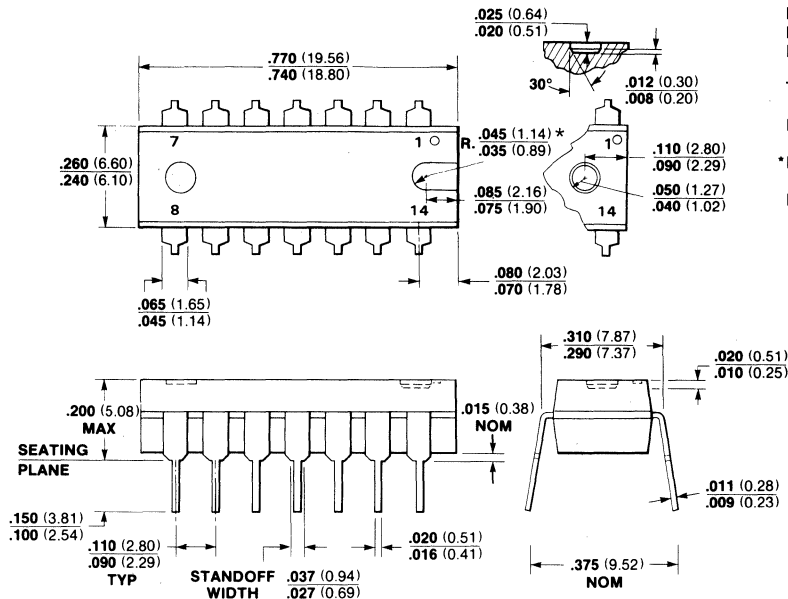


### Notes

- Pins are tin-plated alloy 42
- Cap and base are  $Al_2O_3$
- Pins are intended for insertion in hole rows on .600 (15.24) centers
- They are purposely shipped with "positive" misalignment to facilitate insertion
- Package weight is 7.5 grams

# 9A

## 14-Pin Plastic Dual In-line



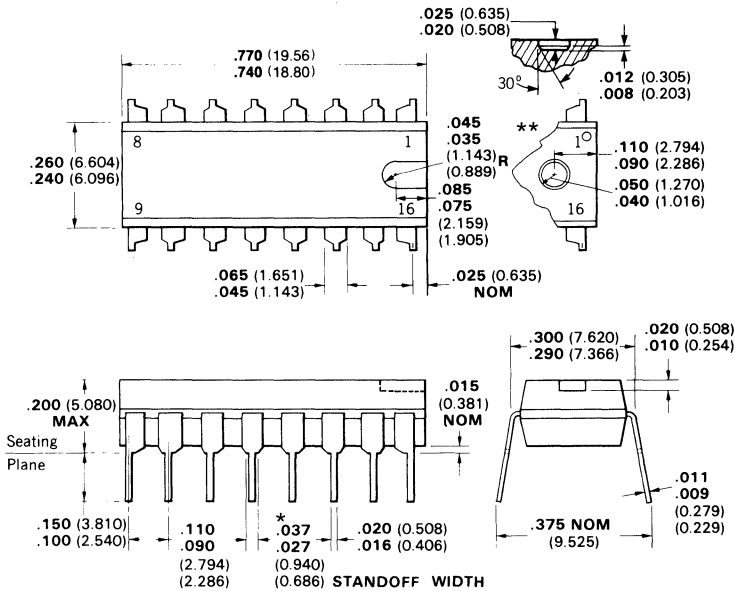
### Notes

- Pins are tin-plated Kovar
- Pins are intended for insertion in hole rows on .300 (7.62) centers
- They are purposely shipped with "positive" misalignment to facilitate insertion
- Board-drilling dimensions should equal your practice for .020 (0.508) diameter pin
- \*Notch or ejector hole varies depending on the product line
- Package weight is 0.9 grams

All dimensions are in inches **bold** and (millimeters)

# 9B

## 16-Pin Plastic Dual In-line



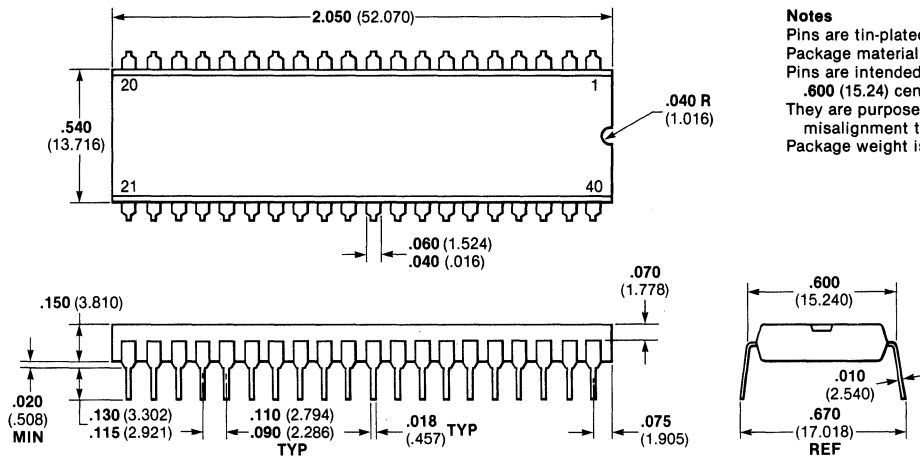
### Notes

- Pins are tin-plated kovar or alloy 42 nickel
- Pins are intended for insertion in hole rows on **.300 (7.62)** centers
- They are purposely shipped with "positive" misalignment to facilitate insertion
- Board drilling dimensions should equal your practice for **.0210 (0.51)** diameter pin
- \*The **.037-0.27 (0.94-0.69)** dimension does not apply to the corner pins
- \*\*Notch or ejector hole varies depending on the product line
- Package weight is 0.9 grams

6

# 9L

## 40-Pin Plastic Dual In-line



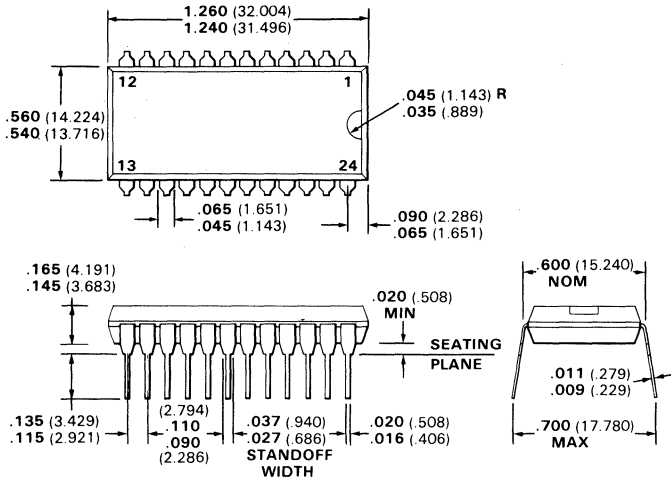
### Notes

- Pins are tin-plated alloy 42
- Package material is plastic
- Pins are intended for insertion in hole rows on **.600 (15.24)** centers
- They are purposely shipped with "positive" misalignment to facilitate insertion
- Package weight is 7.0 grams

All dimensions are in inches **bold** and (millimeters)

# 9N

## 24-Pin Plastic Dual In-line

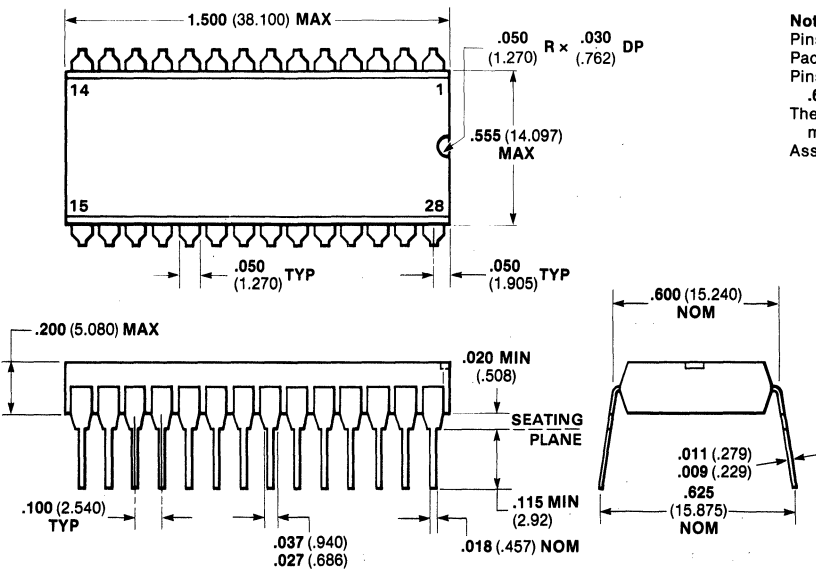


### Notes

- Pins are tin-plated kovar
- Package material is plastic
- Pins are intended for insertion in hole rows on .600 (15.24) centers
- They are purposely shipped with "positive" misalignment to facilitate insertion

# 9Y

## 28-Pin Plastic Dual In-line



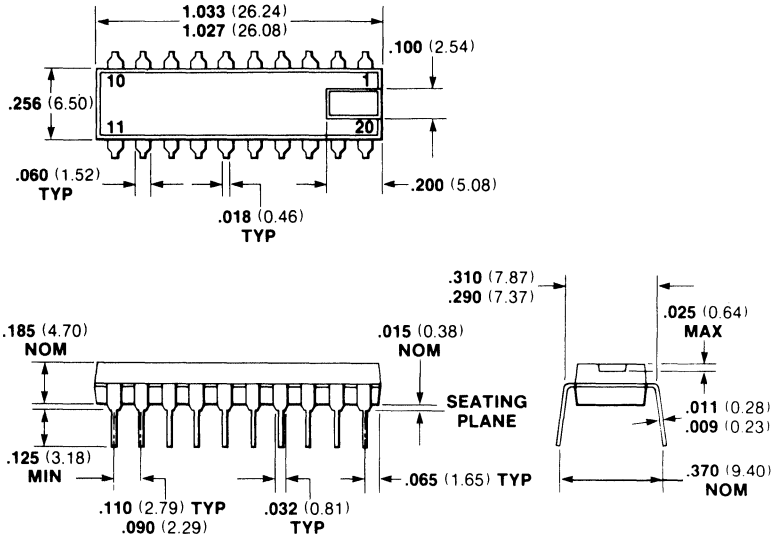
### Notes

- Pins are tin-plated kovar, alloy 42 or copper
- Package material is plastic
- Pins are intended for insertion in hole rows on .600 (15.24) centers
- They are purposely shipped with "positive" misalignment to facilitate insertion
- Assembled package weight is 4.8 grams

All dimensions are in inches **bold** and (millimeters)

# 9Z

## 20-Pin Plastic Dual In-line

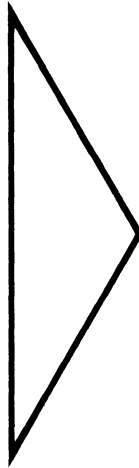
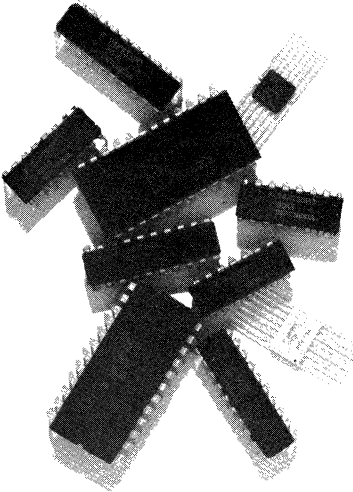


### Notes

- Pins are tin-plated alloy 42 copper (olin 195)
- Pins are intended for insertion in hole rows on **.300** (7.62) centers
- They are purposely shipped with "positive" misalignment to facilitate insertion
- Board-drilling dimensions should equal your practice for **.020** (0.51) diameter pin
- Package weight is a little over 1.0 gram







<b>Product Index and Selection Guide</b>	<b>1</b>
<b>Circuit Characteristics</b>	<b>2</b>
<b>Ratings, Specifications and Waveforms</b>	<b>3</b>
<b>Data Sheets</b>	<b>4</b>
<b>New Products</b>	<b>5</b>
<b>Ordering Information and Package Outlines</b>	<b>6</b>
<b>Sales Offices, Representatives and Distributor Locations</b>	<b>7</b>



## Fairchild Semiconductor

## Franchised Distributors

## United States and Canada

### Alabama

Hall Mark Electronics  
4900 Bradford Drive  
Huntsville, Alabama 35807  
Tel: 205-837-8700 TWX: 810-726-2187

Hamilton/Avnet Electronics  
4692 Commercial Drive  
Huntsville, Alabama 35805  
Tel: 205-837-7210 TWX: 810-726-2162

### Arizona

Hamilton/Avnet Electronics  
505 South Madison Drive  
Tempe, Arizona 85281  
Tel: 602-231-5100 TWX: 910-950-0077

Kierluff Electronics  
4134 East Wood Street  
Phoenix, Arizona 85040  
Tel: 602-243-4101

Wyle Distribution Group  
8155 North 24th Avenue  
Phoenix, Arizona 85021  
Tel: 602-249-2232 TWX: 910-951-4282

### California

Anthem Electronics, Inc.  
21730 Nordhoff Street  
Chatsworth, California 91311  
Tel: 213-700-1000 TWX: 910-493-2083

Anthem Electronics, Inc.  
4125 Sorrento Valley Blvd.  
San Diego, California 92121  
Tel: 714-279-5200

Anthem Electronics, Inc.  
174 Component Drive  
San Jose, California 95131  
Tel: 408-946-8000

Anthem Electronics, Inc.  
2661 Dow Avenue  
Tustin, California 92680  
Tel: 714-730-8000

Arrow Electronics  
9511 Ridge Haven Court  
San Diego, California 92123  
Tel: 714-565-4800 TWX: 910-335-1195

Arrow Electronics  
521 Weddell Avenue  
Sunnyvale, California 94086  
Tel: 408-745-6600 TWX: 910-339-9371

Avnet Electronics  
350 McCormick Avenue  
Costa Mesa, California 92626  
Tel: 714-754-6111 (Orange County)  
213-558-2345 (Los Angeles)  
TWX: 910-595-1928

Bell Industries  
Electronic Distributor Division  
1161 N. Fair Oaks Avenue  
Sunnyvale, California 94086  
Tel: 408-734-8570 TWX: 910-339-9378

Hamilton/Avnet Electronics  
3170 Pullman Avenue  
Costa Mesa, California 92626  
Tel: 714-641-1850 TWX: 910-595-2638

Hamilton Electro Sales  
10912 West Washington Blvd.  
Culver City, California 90230  
Tel: 213-558-2121 TWX: 910-340-6364

Hamilton/Avnet Electronics  
4545 Viewridge Avenue  
San Diego, California 92123  
Tel: 714-571-7527 TWX: 910-335-1216

Hamilton/Avnet Electronics  
1175 Bordeaux Drive  
Sunnyvale, California 94086  
Tel: 408-743-3355 TWX: 910-339-9332

\*\*Sertech Laboratories  
2120 Main Street, Suite 190  
Huntington Beach, California 92647  
Tel: 714-960-1403

Wyle Electronics  
124 Maryland Street  
El Segundo, California 90245  
Tel: 213-322-8100 TWX: 910-348-7111

Wyle Distributor Group  
17872 Cowan Avenue  
Irvine, California 92714  
Tel: 714-641-1600  
Telex: 910-595-1572

Wyle Distributor Group  
18910 Teller Avenue  
Irvine, California 92715  
Tel: 714-851-9955

Wyle Distribution Group  
9525 Chesapeake  
San Diego, California 92123  
Tel: 714-565-9171 TWX: 910-335-1590

Wyle Distribution Group  
3000 Bowers Avenue  
Santa Clara, California 95051  
Tel: 408-727-2500 TWX: 910-338-0541

**Colorado**  
Arrow Electronics  
2121 South Hudson  
Denver, Colorado 80222  
Tel: 303-758-2100 TWX: 910-331-0552

Bell Industries  
8155 West 48th Avenue  
Wheatridge, Colorado 80033  
Tel: 303-424-1985 TWX: 910-938-0393

Hamilton/Avnet Electronics  
8765 E. Orchard Rd., Suite 708  
Englewood, Colorado 80111  
Tel: 303-740-1000 TWX: 910-935-0787

Wyle Distribution Group  
451 East 124th Avenue  
Thornton, Colorado 80241  
Tel: 303-457-9953 TWX: 910-936-0770

### Connecticut

Arrow Electronics  
12 Beaumont Road  
Wallingford, Connecticut 06492  
Tel: 203-265-7741 TWX: 710-476-0162

Hamilton/Avnet Electronics  
Commerce Drive, Commerce Park  
Danbury, Connecticut 06810  
Tel: 203-797-2800 TWX: 710-546-9974

Harvey Electronics  
112 Main Street  
Norwalk, Connecticut 06851  
Tel: 203-853-1515 TWX: 710-468-3373

Schweber Electronics  
Finance Drive  
Commerce Industrial Park  
Danbury, Connecticut 06810  
Tel: 203-792-3500 TWX: 710-456-9405

### Florida

Arrow Electronics  
1001 Northwest 62nd Street  
Suite 108  
Ft. Lauderdale, Florida 33309  
Tel: 305-776-7790 TWX: 510-955-9456

Arrow Electronics  
50 Woodlake Drive West  
Building B  
Palm Bay, Florida 32905  
Tel: 305-725-1480

Hall Mark Electronics  
1671 West McNab Road  
Ft. Lauderdale, Florida 33309  
Tel: 305-971-9280 TWX: 510-956-3092

Hall Mark Electronics  
7233 Lake Ellenor Drive  
Orlando, Florida 32809  
Tel: 305-855-4020 TWX: 810-850-0183

Hamilton/Avnet Electronics  
6801 N.W. 15th Way  
Ft. Lauderdale, Florida 33309  
Tel: 305-971-2900 TWX: 510-955-3097

Hamilton/Avnet Electronics  
3197 Tech Drive, North  
St. Petersburg, Florida 33702  
Tel: 813-576-3930 TWX: 810-863-0374

Schweber Electronics  
2830 North 28th Terrace  
Hollywood, Florida 33020  
Tel: 305-927-0511 TWX: 510-954-0304

### Georgia

Arrow Electronics  
2979 Pacific Drive  
Norcross, Georgia 30071  
Tel: 404-449-8252 TWX: 810-766-0439

Hall Mark Electronics  
6410 Atlantic Blvd., Suite 115  
Norcross, Georgia 30071  
Tel: 404-447-8000 TWX: 810-766-4510

\*\* This distributor carries Fairchild *die* products only.

## Fairchild Semiconductor

Hamilton/Avnet Electronics  
5825-D Peachtree Corners East  
Norcross, Georgia 30092  
Tel: 404-447-7500 TWX: 810-766-0432

### Illinois

Arrow Electronics  
492 Lunt Avenue  
Schaumburg, Illinois 60193  
Tel: 312-893-9420 TWX: 910-291-3544

Hall Mark Electronics  
1177 Industrial Drive  
Bensenville, Illinois 60106  
Tel: 312-860-3800

Hamilton/Avnet Electronics  
1130 Thorndale Avenue  
Bensenville, Illinois 60106  
Tel: 312-860-7780 TWX: 910-227-0060

Kierulff Electronics  
1536 Landmeier Road  
Elk Grove Village, Illinois 60007  
Tel: 312-640-0200 TWX: 910-227-3166

Schweber Electronics  
1275 Brummel Avenue  
Elk Grove Village, Illinois 60007  
Tel: 312-364-3750 TWX: 910-222-3453

### Indiana

Arrow Electronics  
2718 Rand Road  
Indianapolis, Indiana 46241  
Tel: 317-243-9353 TWX: 810-341-3119

Graham Electronics Supply, Inc.  
133 S. Pennsylvania Street  
Indianapolis, Indiana 46204  
Tel: 317-634-8486 TWX: 810-341-3481

Hamilton/Avnet Electronics  
485 Gradle Drive  
Carmel, Indiana 46032  
Tel: 317-844-9333 TWX: 810-260-3966

Pioneer Electronics  
6408 Castle Place Drive  
Indianapolis, Indiana 46250  
Tel: 317-849-7300 TWX: 810-260-1794

### Kansas

Hall Mark Electronics  
10815 Lakeview Drive  
Lenexa, Kansas 66215  
Tel: 913-888-4747

Hamilton/Avnet Electronics  
9219 Quivira Road  
Overland Park, Kansas 66215  
Tel: 913-888-8900 TWX: 910-743-0005

### Maryland

Hall Mark Electronics  
6655 Amberton Drive  
Baltimore, Maryland 21227  
Tel: 301-796-9300

Hamilton/Avnet Electronics  
6822 Oak Hall Lane  
Columbia, Maryland 21045  
Tel: 301-995-3500 TWX: 710-862-1861

## Franchised Distributors

Pioneer Electronics  
9100 Gaither Road  
Gaithersburg, Maryland 20760  
Tel: 301-948-0710 TWX: 710-828-9784

Schweber Electronics  
9218 Gaither Road  
Gaithersburg, Maryland 20760  
Tel: 301-840-5900 TWX: 710-828-9749

### Massachusetts

Arrow Electronics  
Arrow Drive  
Woburn, Massachusetts 01801  
Tel: 617-933-8130 TWX: 710-392-6770

Cadence Electronics  
15 Strathmore Road  
Natick, Massachusetts 01760  
Tel: 617-879-3000 TWX: 710-346-0397

Gerber Electronics  
128 Carnegie Row  
Norwood, Massachusetts 02062  
Tel: 617-329-2400

Hamilton/Avnet Electronics  
50 Tower Office Park  
Woburn, Massachusetts 01801  
Tel: 617-273-7500 TWX: 710-393-0382

Harvey Electronics  
44 Hartwell Avenue  
Lexington, Massachusetts 02173  
Tel: 617-861-9200 TWX: 710-326-6617

Schweber Electronics  
25 Wiggins Avenue  
Bedford, Massachusetts 01730  
Tel: 617-275-5100 TWX: 710-326-0268

\*\*Sertech Laboratories  
1 Peabody Street  
Salem, Massachusetts 01970  
Tel: 617-745-2450

### Michigan

Arrow Electronics  
3810 Varsity Drive  
Ann Arbor, Michigan 48104  
Tel: 313-971-8220 TWX: 810-223-6020

Hamilton/Avnet Electronics  
2215 29th Street S.E.  
Space A5  
Grand Rapids, Michigan 49508  
Tel: 616-243-8805 TWX: 810-273-6921

Hamilton/Avnet Electronics  
32487 Schoolcraft  
Livonia, Michigan 48150  
Tel: 313-522-4700 TWX: 810-242-8775

Pioneer Electronics  
13485 Stamford  
Livonia, Michigan 48150  
Tel: 313-525-1800

Schweber Electronics  
33540 Schoolcraft  
Livonia, Michigan 48150  
Tel: 313-525-8100 TWX: 810-242-2983

## United States and Canada

### Minnesota

Arrow Electronics  
5230 West 73rd Street  
Edina, Minnesota 55435  
Tel: 612-830-1800 TWX: 910-576-3125

Hamilton/Avnet Electronics  
10300 Bren Road East  
Minnetonka, Minnesota 55343  
Tel: 612-932-0600 TWX: 910-576-2720

Schweber Electronics  
7422 Washington Avenue S.  
Eden Prairie, Minnesota 55344  
Tel: 612-941-5280 TWX: 910-576-3167

### Missouri

Hall Mark Electronics  
13789 Rider Trail  
Earth City, Missouri 63045  
Tel: 314-291-5350

Hamilton/Avnet Electronics  
13743 Shoreline Court, East  
Earth City, Missouri 63045  
Tel: 314-344-1200 TWX: 910-762-0606

### New Hampshire

Arrow Electronics  
1 Perimeter Road  
Manchester, New Hampshire 03103  
Tel: 603-668-6968 TWX: 710-220-1684

### New Jersey

Arrow Electronics  
Pleasant Valley Avenue  
Moorestown, New Jersey 08057  
Tel: 609-235-1900 TWX: 710-897-0829

Arrow Electronics  
285 Midland Avenue  
Saddle Brook, New Jersey 07662  
Tel: 201-797-5800 TWX: 710-988-2206

Hall Mark Electronics  
Springdale Business Center  
2091 Springdale Road  
Cherry Hill, New Jersey 08003  
Tel: 609-424-0880

Hamilton/Avnet Electronics  
10 Industrial Road  
Fairfield, New Jersey 07006  
Tel: 201-575-3390 TWX: 710-734-4388

Hamilton/Avnet Electronics  
#1 Keystone Avenue  
Cherry Hill, New Jersey 08003  
Tel: 609-424-0100 TWX: 710-940-0262

Harvey Electronics  
45 Route 46  
Pinebrook, New Jersey 07058  
Tel: 201-575-3510 TWX: 710-734-4382

Schweber Electronics  
18 Madison Road  
Fairfield, New Jersey 07006  
Tel: 201-227-7880 TWX: 710-734-4305

Sterling Electronics  
774 Pfeiffer Blvd.  
Perth Amboy, New Jersey 08861  
Tel: 201-442-8000 Telex: 138-679

\*\*This distributor carries Fairchild *die* products only.

## Fairchild Semiconductor

## Franchised Distributors

## United States and Canada

### New Mexico

Arrow Electronics  
2460 Alamo Avenue S.E.  
Albuquerque, New Mexico 87106  
Tel: 505-243-4566 TWX: 910-889-1679

Bell Industries  
11728 Linn Avenue N.E.  
Albuquerque, New Mexico 87123  
Tel: 505-292-2700 TWX: 910-989-0625

Hamilton/Avnet Electronics  
2524 Baylor Drive, S.E.  
Albuquerque, New Mexico 87106  
Tel: 505-765-1500 TWX: 910-989-0614

### New York

Arrow Electronics  
900 Broadhollow Road  
Farmingdale, New York 11735  
Tel: 516-694-6800  
TWX: 510-224-6155 & 510-224-6126

Arrow Electronics  
20 Oser Avenue  
Hauppauge, New York 11787  
Tel: 516-231-1000

Arrow Electronics  
P.O. Box 370  
7705 Maitlage Drive  
Liverpool, New York 13088  
Tel: 315-652-1000 TWX: 710-545-0230

\*Cadence Electronics  
40-17 Oser Avenue  
Hauppauge, New York 11787  
Tel: 516-231-6722

Components Plus, Inc.  
40 Oser Avenue  
Hauppauge, New York 11787  
Tel: 516-231-9200 TWX: 510-227-9869

Hamilton/Avnet Electronics  
5 Hub Drive  
Melville, New York 11746  
Tel: 516-454-6000 TWX: 510-224-6166

Hamilton/Avnet Electronics  
333 Metro Park  
Rochester, New York 14623  
Tel: 716-475-9130 TWX: 510-253-5470

Hamilton/Avnet Electronics  
16 Corporate Circle  
E. Syracuse, New York 13057  
Tel: 315-437-2642 TWX: 710-541-1560

Harvey Electronics  
(mailing address)  
P.O. Box 1208  
Binghamton, New York 13902  
(shipping address)  
1911 Vestal Parkway East  
Vestal, New York 13850  
Tel: 607-748-8211

Harvey Electronics  
60 Crossways Park West  
Woodbury, New York 11797  
Tel: 516-921-8920 TWX: 510-221-2184

Schweber Electronics  
Jericho Turnpike  
Westbury, L.I., New York 11590  
Tel: 516-334-7474 TWX: 910-222-3660

Summit Distributors, Inc.  
916 Main Street  
Buffalo, New York 14202  
Tel: 716-884-3450 TWX: 710-522-1692

### North Carolina

Arrow Electronics  
938 Burke Street  
Winston Salem, North Carolina 27102  
Tel: 919-725-8711 TWX: 510-931-3169

Hall Mark Electronics  
1208 Front Street, Bldg. K  
Raleigh, North Carolina 27609  
Tel: 919-823-4465 TWX: 510-928-1831

Hamilton/Avnet Electronics  
2803 Industrial Drive  
Raleigh, North Carolina 27609  
Tel: 919-829-8030 TWX: 510-928-1836

Pioneer Electronics  
103 Industrial Drive  
Greensboro, North Carolina 27406  
Tel: 919-273-4441

### Ohio

Arrow Electronics  
7620 McEwen Road  
Centerville, Ohio 45459  
Tel: 513-435-5563 TWX: 810-459-1611

Arrow Electronics  
6238 Cochran Road  
Solon, Ohio 44139  
Tel: 216-248-3990 TWX: 810-427-9409

Hamilton/Avnet Electronics  
954 Senate Drive  
Dayton, Ohio 45459  
Tel: 513-433-0610 TWX: 810-450-2531

Hamilton/Avnet Electronics  
4588 Emery Industrial Parkway  
Warrensville Heights, Ohio 44128  
Tel: 216-831-3500 TWX: 810-427-9452

Pioneer Electronics  
4800 E. 131st Street  
Cleveland, Ohio 44105  
Tel: 216-587-3600

Pioneer Electronics  
4433 Interpoint Blvd.  
Dayton, Ohio 45424  
Tel: 513-236-9900 TWX: 810-459-1622

Schweber Electronics  
23880 Commerce Park Road  
Beachwood, Ohio 44122  
Tel: 216-464-2970 TWX: 810-427-9441

### Oklahoma

Hall Mark Electronics  
5460 S. 103rd East Avenue  
Tulsa, Oklahoma 74145  
Tel: 918-665-3200 TWX: 910-845-2290

### Oregon

Hamilton/Avnet Electronics  
6024 S.W. Jean Road  
Building C, Suite 10  
Lake Oswego, Oregon 97034  
Tel: 503-635-8157 TWX: 910-455-8179

### Pennsylvania

Arrow Electronics  
650 Seco Road  
Monroeville, Pennsylvania 15146  
Tel: 412-856-7000

Pioneer Electronics  
261 Gibraltar Road  
Horsham, Pennsylvania 19044  
Tel: 215-674-4000 TWX: 510-665-6778

Pioneer Electronics  
259 Kappa Drive  
Pittsburgh, Pennsylvania 15238  
Tel: 412-782-2300 TWX: 710-795-3122

Schweber Electronics  
101 Rock Road  
Horsham, Pennsylvania 19044  
Tel: 215-441-0600 TWX: 510-665-6540

### Texas

Arrow Electronics  
13715 Gamma Road  
Dallas, Texas 75234  
Tel: 214-386-7500 TWX: 910-860-5377

Arrow Electronics  
10700 Corporate Drive, Suite 100  
Stafford, Texas 77477  
Tel: 713-491-4100 TWX: 910-880-4439

Hall Mark Electronics  
12211 Technology Blvd.  
Austin, Texas 78759  
Tel: 512-258-8848

Hall Mark Electronics  
11333 Page Mill Drive  
Dallas, Texas 75243  
Tel: 214-343-5000 TWX: 910-867-4721

Hall Mark Electronics  
8000 Westglen  
Houston, Texas 77063  
Tel: 713-781-6100

Hamilton/Avnet Electronics  
2401 Rutland Drive  
Austin, Texas 78758  
Tel: 512-837-8911 TWX: 910-874-1319

Hamilton/Avnet Electronics  
8750 Westpark  
Houston, Texas 77063  
Tel: 713-780-1771 TWX: 910-881-5523

Hamilton/Avnet Electronics  
2111 W. Walnut Hill Lane  
Irving, Texas 75062  
Tel: 214-659-4111 TWX: 910-860-5929

\*Minority Distributor

---

**Fairchild  
Semiconductor****Franchised  
Distributors****United States and  
Canada**

---

Schweber Electronics, Inc.  
4202 Beltway Drive  
Dallas, Texas 75234  
Tel: 214-661-5010 TWX: 910-860-5493

Schweber Electronics, Inc.  
10625 Richmond, Suite 100  
Houston, Texas 77042  
Tel: 713-784-3600 TWX: 910-881-4836

Sterling Electronics  
4201 Southwest Freeway  
Houston, Texas 77027  
Tel: 713-627-9800 TWX: 910-881-5042  
Telex: STELECO HOUA 77-5299

**Utah**

Bell Industries  
3639 West 2150 South  
Salt Lake City, Utah 84120  
Tel: 801-972-6969 TWX: 910-925-5686

Hamilton/Avnet Electronics  
1585 West 2100 South  
Salt Lake City, Utah 04119  
Tel: 801-972-2800 TWX: 910-925-4018

**Washington**

Arrow Electronics  
14320 N.E. 21st Street  
Bellevue, Washington 98005  
Tel: 206-643-4800 TWX: 910-443-3033

Hamilton/Avnet Electronics  
14212 N.E. 21st Street  
Bellevue, Washington 98005  
Tel: 206-453-5844 TWX: 910-443-2469

Radar Electronic Co., Inc.  
168 Western Avenue W.  
Seattle, Washington 98119  
Tel: 206-282-2511 TWX: 910-444-2052

Wyle Distribution Group  
1750 132nd Avenue N.E.  
Bellevue, Washington 98005  
Tel: 206-453-8300 TWX: 910-444-1379

**Wisconsin**

Hall Mark Electronics  
9657 South 20th Street  
Oakcreek, Wisconsin 53154  
Tel: 414-761-3000

Hamilton/Avnet Electronics  
2975 South Moorland Road  
New Berlin, Wisconsin 53151  
Tel: 414-784-4510 TWX: 910-262-1182

**Canada**

Future Electronics Inc.  
4800 Dufferin Street  
Downsview, Ontario, M3H 5S8, Canada  
Tel: 416-663-5583

Future Electronics Inc.  
Baxter Center  
1050 Baxter Road  
Ottawa, Ontario, K2C 3P2, Canada  
Tel: 613-820-8313

Future Electronics Inc.  
237 Hymus Blvd.  
Pointe Claire (Montreal), Quebec, H9R 5C7, Canada  
Tel: 514-694-7710 TWX: 610-421-3251

Hamilton/Avnet Canada Ltd.  
6845 Rexwood Road, Units 3-4-5  
Mississauga, Ontario, L4V 1R2, Canada  
Tel: 416-677-7432 TWX: 610-492-8867

Hamilton/Avnet Canada Ltd.  
210 Colonnade Road  
Nepean, Ontario, K2E 7L5, Canada  
Tel: 613-226-1700 Tlx: 0534-971

Hamilton/Avnet Canada Ltd.  
2670 Sabourin Street  
St. Laurent, Quebec, H4S 1M2, Canada  
Tel: 514-331-6443 TWX: 610-421-3731

Semad Electronics Ltd.  
620 Meloche Avenue  
Dorval, Quebec, H9P 2P4, Canada  
Tel: 604-299-8866 TWX: 610-422-3048

Semad Electronics Ltd.  
105 Brisbane Avenue  
Downsview, Ontario, M3J 2K6, Canada  
Tel: 416-663-5670 TWX: 610-492-2510

Semad Electronics Ltd.  
864 Lady Ellen Place  
Ottawa, Ontario K1Z 5M2, Canada  
Tel: 613-722-6571 TWX: 610-562-1923

---

**Fairchild  
Semiconductor****Sales  
Representatives****United States and  
Canada**

---

**California**

Magna Sales, Inc.  
3333 Bowers Avenue, Suite 295  
Santa Clara, California 95051  
Tel: 408-727-8753 TWX: 910-338-0241

**Colorado**

Simpson Associates, Inc.  
2552 Ridge Road  
Littleton, Colorado 80120  
Tel: 303-794-8381 TWX: 910-935-0719

**Illinois**

Micro Sales, Inc.  
54 W. Seegers Road  
Arlington Heights, Illinois 60005  
Tel: 312-956-1000 TWX: 910-222-1833

**Maryland**

Delta III Associates  
1000 Century Plaza, Suite 224  
Columbia, Maryland 21044  
Tel: 301-730-4700 TWX: 710-826-9654

**Massachusetts**

Spectrum Associates, Inc.  
109 Highland Avenue  
Needham, Massachusetts 02192  
Tel: 617-444-8600 TWX: 710-325-6665

**Missouri**

Micro Sales, Inc.  
514 Earth City Plaza, Suite 314  
Earth City, Missouri 63045  
Tel: 314-739-7446

**Nevada**

Magna Sales, Inc.  
4560 Wagon Wheel Road  
Carson City, Nevada 89701  
Tel: 702-883-1471

**New York**

Tri-Tech Electronics, Inc.  
3215 E. Main Street  
Endwell, New York 13760  
Tel: 607-754-1094 TWX: 510-252-0891

Tri-Tech Electronics, Inc.  
590 Perinton Hills Office Park  
Fairport, New York 14450  
Tel: 716-223-5720 TWX: 510-253-6356

Tri-Tech Electronics, Inc.  
6836 E. Genesee Street  
Fayetteville, New York 13066  
Tel: 315-446-2881 TWX: 710-541-0604

Tri-Tech Electronics, Inc.  
19 Davis Avenue  
Poughkeepsie, New York 12603  
Tel: 914-473-3880 TWX: 510-253-6356

**Oregon**

Magna Sales, Inc.  
8285 S.W. Nimbus Avenue, Suite 138  
Beaverton, Oregon 97005  
Tel: 503-641-7045 TWX: 910-467-8742

**Utah**

Simpson Associates, Inc.  
7324 South 1300 East, Suite 350  
Midvale, Utah 84047  
Tel: 801-566-3691 TWX: 910-925-4031

**Washington**

Magna Sales, Inc.  
Benaroya Business Park  
Building 3, Suite 115  
300 120th Avenue, N.E.  
Bellevue, Washington 98004  
Tel: 206-455-3190

**Wisconsin**

Larsen Associates  
10855 West Potter Road  
Wauwatosa, Wisconsin 53226  
Tel: 414-258-0529 TWX: 910-262-3160



## Fairchild Semiconductor

## Sales Offices

## United States and Canada

### Alabama

Huntsville Office  
500 Wynn Drive, Suite 511  
Huntsville, Alabama 35805  
Tel: 205-837-8960

### Arizona

Phoenix Office  
2255 West Northern Road, Suite B112  
Phoenix, Arizona 85021  
Tel: 602-864-1000 TWX: 910-951-1544

### California

Los Angeles Office\*  
Crocker Bank Bldg.  
15760 Ventura Blvd., Suite 1027  
Encino, California 91436  
Tel: 213-990-9800 TWX: 910-495-1776

### San Diego Office\*

4355 Ruffin Road, Suite 100  
San Diego, California 92123  
Tel: 714-560-1332

### Santa Ana Office\*

1570 Brookhollow Drive, Suite 206  
Santa Ana, California 92705  
Tel: 714-557-7350 TWX: 910-595-1109

### Santa Clara Office\*

3333 Bowers Avenue, Suite 299  
Santa Clara, California 95051  
Tel: 408-987-9530 TWX: 910-338-0241

### Colorado

Denver Office  
7200 East Hampden Avenue, Suite 206  
Denver, Colorado 80224  
Tel: 303-758-7924

### Connecticut

Danbury Office  
57 North Street, #206  
Danbury, Connecticut 06810  
Tel: 203-744-4010

### Florida

Ft. Lauderdale Office  
Executive Plaza, Suite 112  
1001 Northwest 62nd Street  
Ft. Lauderdale, Florida 33309  
Tel: 305-771-0320 TWX: 510-955-4098

### Orlando Office\*

Crane's Roost Office Park  
399 Whooping Loop  
Altamonte Springs, Florida 32701  
Tel: 305-834-7000 TWX: 810-850-0152

### Georgia

Atlanta Sales Office  
Interchange Park, Bldg. 2  
4183 N.E. Expressway  
Atlanta, Georgia 30340  
Tel: 404-939-7683

### Illinois

Itasca Office  
500 Park Blvd., Suite 575  
Itasca, Illinois 60143  
Tel: 312-773-3300

### Indiana

Ft. Wayne Office  
2118 Inwood Drive, Suite 111  
Ft. Wayne, Indiana 46815  
Tel: 219-483-6453 TWX: 810-332-1507

### Indianapolis Office

7202 N. Shadeland, Room 205  
Castle Point  
Indianapolis, Indiana 46250  
Tel: 317-849-5412 TWX: 810-260-1793

### Kansas

Kansas City Office  
8600 West 110th Street, Suite 209  
Overland Park, Kansas 66210  
Tel: 913-649-3974

### Maryland

Columbia Office  
1000 Century Plaza, Suite 225  
Columbia, Maryland 21044  
Tel: 301-730-1510 TWX: 710-826-9654

### Massachusetts

Framingham Office  
5 Speen Street  
Framingham, Massachusetts 01701  
Tel: 617-872-4900 TWX: 710-380-0599

### Michigan

Detroit Office\*  
21999 Farmington Road  
Farmington Hills, Michigan 48024  
Tel: 313-478-7400 TWX: 810-242-2973

### Minnesota

Minneapolis Office\*  
4570 West 77th Street, Room 356  
Minneapolis, Minnesota 55435  
Tel: 612-835-3322 TWX: 910-576-2944

### New Jersey

New Jersey Office  
Vreeland Plaza  
41 Vreeland Avenue  
Totowa, New Jersey 07511  
Tel: 201-256-9006

### New Mexico

Albuquerque Office  
North Building  
2900 Louisiana N.E. South G2  
Albuquerque, New Mexico 87110  
Tel: 505-884-5601 TWX: 910-379-6435

### New York

Fairport Office  
815 Ayrault Road  
Fairport, New York 14450  
Tel: 716-223-7700

### Melville Office

275 Broadhollow Road, Suite 219  
Melville, New York 11747  
Tel: 516-293-2900 TWX: 510-224-6480

### Poughkeepsie Office

19 Davis Avenue  
Poughkeepsie, New York 12603  
Tel: 914-473-5730 TWX: 510-248-0030

### North Carolina

Raleigh Office  
1100 Navaho Drive, Suite 112  
Raleigh, North Carolina 27609  
Tel: 919-876-9643

### Ohio

Dayton Office  
5045 North Main Street, Suite 105  
Dayton, Ohio 45414  
Tel: 513-278-8278 TWX: 810-459-1803

### Oklahoma

Tulsa Office  
9810 East 42nd Street, Suite 127  
Tulsa, Oklahoma 74145  
Tel: 918-627-1591

### Oregon

Portland Office  
8285 S.W. Nimbus Avenue, Suite 138  
Beaverton, Oregon 97005  
Tel: 503-641-7871 TWX: 910-467-7842

### Pennsylvania

Philadelphia Office\*  
2500 Office Center  
2500 Maryland Road  
Willow Grove, Pennsylvania 19090  
Tel: 215-657-2711

### Tennessee

Knoxville Office  
Executive Square II  
9051 Executive Park Drive, Suite 502  
Knoxville, Tennessee 37923  
Tel: 615-691-4011

### Texas

Austin Office  
8240 Mopac Expressway, Suite 270  
Austin, Texas 78759  
Tel: 512-837-8931

### Dallas Office

1702 North Collins Street, Suite 101  
Richardson, Texas 75081  
Tel: 214-234-3391 TWX: 910-867-4757

### Houston Office

9896 Bissonnet-2., Suite 470  
Houston, Texas 77036  
Tel: 713-771-3547 TWX: 910-881-8278

### Canada

Toronto Regional Office  
2375 Steeles Avenue West, Unit 203  
Downsview, Ontario M3J 3A8, Canada  
Tel: 416-665-5903 TWX: 610-491-1283

\*Field Application Engineer

## Fairchild Semiconductor

## Sales Offices

## International

### Australia

Fairchild Australia Pty Ltd.  
Branch Office Third Floor  
F.A.I. Insurance Building  
619 Pacific Highway  
St. Leonards 2065  
New South Wales, Australia  
Tel: (02)-439-5911  
Telex: AA20053

### Austria and Eastern Europe

Fairchild Electronics  
A-1010 Wien  
Schwedenplatz 2  
Tel: 0222 635821 Telex: 75096

### Benelux

Fairchild Semiconductor  
Ruysdaelbaan 35  
5613 Dx Eindhoven  
The Netherlands  
Tel: 00-31-40-446909 Telex: 00-1451024

### Brazil

Fairchild Semiconductores Ltda.  
Caixa Postal 30407  
Rua Alagoas, 663  
01242 Sao Paulo, Brazil  
Tel: 66-9092 Telex: 011-23831  
Cable: FAIRLEC

### France

Fairchild Camera & Instrument S.A.  
121, Avenue d'Italie  
75013 Paris, France  
Tel: 331-584-55 66  
Telex: 0042 200614 or 260937

### Germany

Fairchild Camera and Instrument GmBH  
Daimlerstrasse 15  
8046 Garching Hochbruck  
Munich, Germany  
Tel: (089) 320031 Telex: 52 4831 fair d

Fairchild Camera and Instrument GmBH  
Oeltzenstrasse 15  
3000 Hannover  
W. Germany  
Tel: 0511 17844 Telex: 09 22922

Fairchild Camera and Instrument GmBH

Poststrasse 37  
7251 Leonberg  
W. Germany  
Tel: 07152 41026 Telex: 07 245711

### Hong Kong

Fairchild Semiconductor (HK) Ltd.  
135 Hoi Bun Road  
Kwun Tong  
Kowloon, Hong Kong  
Tel: 3-440233 and 3-890271  
Telex: HKG-531

### Italy

Fairchild Semiconductori, S.P.A.  
Via Flamenia Vecchia 653  
00191 Roma, Italy  
Tel: 06 327 4006 Telex: 63046 (FAIR ROM)

Fairchild Semiconductori S.P.A.  
Viale Corsica 7  
20133 Milano, Italy  
Tel: 296001-5 Telex: 843-330522

### Japan

Fairchild Japan Corporation  
Pola Bldg.  
1-15-21, Shibuya  
Shibuya-Ku, Tokyo 150, Japan  
Tel: 03 400 8351 Telex: 242173

Fairchild Japan Corporation  
Yotsubashi Chuo Bldg.  
1-4-26, Shinmachi  
Nishi-Ku, Osaka 550, Japan  
Tel: 06-541-6138/9

### Korea

Fairchild Semikor Ltd.  
K2 219-6 Gari Bong Dong  
Young Dug Po-Ku  
Seoul 150-06, Korea  
Tel: 85-0067 Telex: FAIRKOR 22705

(mailing address)  
Central P.O. Box 2806

### Mexico

Fairchild Mexicana S.A.  
Blvd. Adolfo Lopez Mateos No. 163  
Mexico 19, D.F.  
Tel: 905-563-5411 Telex: 017-71-038

### Scandinavia

Fairchild Semiconductor AB  
Svartengsgatan 6  
S-11620 Stockholm  
Sweden  
Tel: 8-449255 Telex: 17759

### Singapore

Fairchild Semiconductor Pty. Ltd.  
No. 11, Lorong 3  
Toa Payoh  
Singapore 12  
Tel: 531-066 Telex: FAIRSIN-RS 21376

### Taiwan

Fairchild Semiconductor Ltd.  
Hsietsu Bldg., Room 502  
47 Chung Shan North Road  
Sec. 3 Taipei, Taiwan  
Tel: 573205 thru 573207

### United Kingdom

Fairchild Camera and Instrument Ltd.  
Semiconductor Division  
230 High Street  
Potters Bar  
Hertfordshire EN6 5BU  
England  
Tel: 0707 51111 Telex: 262835

Fairchild Semiconductor Ltd.  
17 Victoria Street  
Craigshill  
Livingston  
West Lothian, Scotland -EH54 5BG  
Tel: Livingston 0506 32891 Telex: 72629

GEC-Fairchild Ltd.  
Chester High Road  
Neston  
South Wirral L64 3UE  
Cheshire, England  
Tel: 051-336-3975 Telex: 629701



**54F/74F Family DC Characteristics<sup>1</sup>**

Symbol	Parameter		Limits <sup>2</sup>			Units	V <sub>CC</sub> <sup>4</sup>	Conditions <sup>2</sup>	
			Min	Typ <sup>3</sup>	Max				
V <sub>IH</sub>	Input HIGH Voltage		2.0			V		Recognized as a HIGH Signal over Recommended V <sub>CC</sub> and T <sub>A</sub> Range	
V <sub>IL</sub>	Input LOW Voltage		0.8			V		Recognized as a LOW Signal over Recommended V <sub>CC</sub> and T <sub>A</sub> Range	
V <sub>CD</sub>	Input Clamp Diode Voltage		-1.2			V	Min	I <sub>IN</sub> = -18 mA	
V <sub>OH</sub>	Output HIGH Voltage	Std <sup>6</sup> Mil	2.5	3.4		V	Min	I <sub>OH</sub> = 40 μA Multiplied by Output HIGH U.L. Shown on Data Sheet	
		Std <sup>6</sup> Com	2.7	3.4					
V <sub>OL</sub>	Output LOW Voltage		0.35			0.5	V	Min	I <sub>OL</sub> = 1.6 mA Multiplied by Output LOW U.L. Shown on Data Sheet
I <sub>IH</sub>	Input HIGH Current	0.5 U.L.				20	μA	Max	I <sub>IH</sub> = 40 μA Multiplied by Input HIGH U.L. Shown on Data Sheet; V <sub>IN</sub> = 2.7 V
		1.0 U.L.				40			
		n U.L.				n(40)			
	Input HIGH Current, Breakdown Test, All Inputs					100	μA	Max	V <sub>IN</sub> = 7.0 V
I <sub>IL</sub>	Input LOW Current	0.375 U.L.				-0.6	mA	Max	I <sub>IL</sub> = -1.6 mA Multiplied by Input LOW U.L. Shown on Data Sheet; V <sub>IN</sub> = 0.5 V
		0.75 U.L.				-1.2			
		n U.L.				n(-1.6)			
I <sub>OZH</sub>	3-State Output OFF Current HIGH					50	μA	Max	V <sub>OUT</sub> = 2.4 V
I <sub>OZL</sub>	3-State Output OFF Current LOW					-50	μA	Max	V <sub>OUT</sub> = 0.5 V
I <sub>OS</sub> <sup>5</sup>	Output Short-Circuit Current	Standard <sup>6</sup> /3-State	-60		-150	mA	Max	V <sub>OUT</sub> = 0 V	
		Buffers/Line Dvrs	-100		-225				

1. Unless otherwise noted, conditions and limits apply throughout the temperature range for which the particular device type is rated. The ground pin is the reference level for all applied and resultant voltages.
2. Unless otherwise stated on individual data sheets.
3. Typical characteristics refer to T<sub>A</sub> = +25°C and V<sub>CC</sub> = +5.0 V.
4. Min and Max refer to the values listed in the table of recommended operating conditions.
5. For testing I<sub>OS</sub>, the use of high-speed test apparatus and/or sample-and-hold techniques are preferable in order to minimize internal heating and more accurately reflect operational values. Otherwise, prolonged shorting of a HIGH output may raise the chip temperature well above normal and thereby cause invalid readings in other parameter tests. In any sequence of parameter tests, I<sub>OS</sub> tests should be performed last.
6. Standard refers to the totem-pole pull-up circuitry commonly used for the particular family, as distinguished from buffers, line drivers or 3-state outputs.

**FAIRCHILD**

A Schlumberger Company

Fairchild reserves the right to make changes in the circuitry or specifications in this book at any time without notice. Manufactured under one of the following U.S. Patents: 2981877, 3015048, 3064167, 3108359, 3117260; other patents pending. Fairchild cannot assume responsibility for use of any circuitry described other than circuitry entirely embodied in a Fairchild product. No other circuit patent licenses are implied.